

SUZUKI

AN650

SERVICE MANUAL



FOREWORD

This manual contains an introductory description on the SUZUKI AN650 and procedures for its inspection/service and overhaul of its main components. Other information considered as generally known is not included.

Read the GENERAL INFORMATION section to familiarize yourself with the motorcycle and its maintenance. Use this section as well as other sections to use as a guide for proper inspection and service. This manual will help you know the motorcycle better so that you can assure your customers of fast and reliable service.

- * This manual has been prepared on the basis of the latest specifications at the time of publication. If modifications have been made since then, differences may exist between the content of this manual and the actual motorcycle.
- * Illustrations in this manual are used to show the basic principles of operation and work procedures. They may not represent the actual motorcycle exactly in detail.
- * This manual is written for persons who have enough knowledge, skills and tools, including special tools, for servicing SUZUKI motorcycles. If you do not have the proper knowledge and tools, ask your authorized SUZUKI motorcycle dealer to help you.

▲ WARNING

Inexperienced mechanics or mechanics without the proper tools and equipment may not be able to properly perform the services described in this manual. Improper repair may result in injury to the mechanic and may render the motorcycle unsafe for the rider and passenger.

SUZUKI MOTOR CORPORATION

GROUP INDEX

GENERAL INFORMATION	1
PERIODIC MAINTENANCE	2
ENGINE	3
DRIVE TRAIN	4
CVT	5
FI SYSTEM/ CVT SYSTEM	6
FUEL SYSTEM AND THROTTLE BODY	7
COOLING AND LUBRICATION SYSTEM	8
CHASSIS	9
ELECTRICAL SYSTEM	10
SERVICING INFORMATION	11
EMISSION CONTROL INFORMATION	12
WIRING DIAGRAM	13

HOW TO USE THIS MANUAL

TO LOCATE WHAT YOU ARE LOOKING FOR:

1. The text of this manual is divided into sections.
2. The section titles are listed in the **GROUP INDEX**.
3. Holding the manual as shown at the right will allow you to find the first page of the section easily.
4. The contents are listed on the first page of each section to help you find the item and page you need.

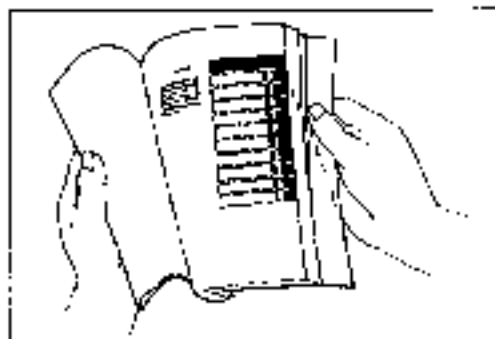

COMPONENT PARTS AND WORK TO BE DONE





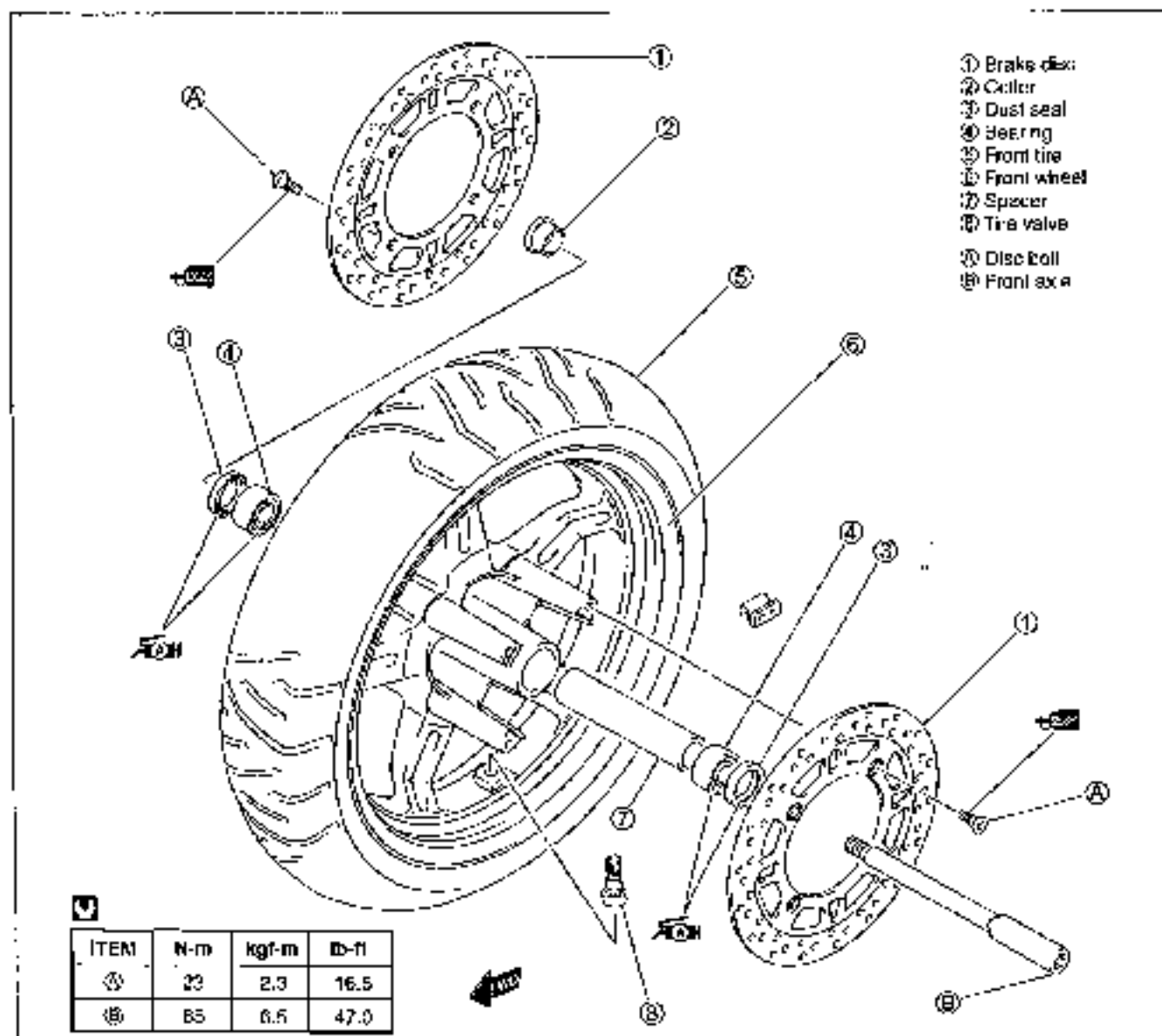















Under the name of each system or unit, is its exploded view. Work instructions and other service information such as the tightening torque, lubricating points and locking agent points, are provided.

Example. Front wheel



SYMBOL

Listed in the table below are the symbols indicating instructions and other information necessary for servicing. The meaning of each symbol is also included in the table.

SYMBOL	DEFINITION	SYMBOL	DEFINITION
	Torque control required Data beside it indicates specified torque.		Use engine coolant. 99000-99032-11X
	Apply oil. Use engine oil unless otherwise specified.		Use fork oil. 99000-99044-10G
	Apply molybdenum oil solution. (Mixture of engine oil and SUZUKI MOLY PASTE in a ratio of 1 : 1)		Apply or use brake fluid.
	Apply SUZUKI SUPER GREASE "A". 99000-25010		Measure in voltage range.
	Apply SUZUKI MOLY PASTE. 99000-25140		Measure in current range.
	Apply SUZUKI BOND "1207B". 99104-31140 (USA)		Measure in resistance range.
	Apply SUZUKI BOND "1215". 99000-31110 (Except USA)		Measure in diode test range.
	Apply SUZUKI BOND "1216B". 99000-31230		Measure in continuity test range.
	Apply THREAD LOCK SUPER "1303". 99000-32030		Use special tool.
	Apply THREAD LOCK "1342". 99000-32050		Indication of service data.
	Apply THREAD LOCK SUPER "1360". 99000-32130		

ABBREVIATIONS USED IN THIS MANUAL

A

ABDC	: After Bottom Dead Center
AC	: Alternating Current
ACL	: Air Cleaner, Air Cleaner Box
API	: American Petroleum Institute
ATDC	: After Top Dead Center
ATM Pressure	: Atmospheric Pressure
	Atmospheric Pressure Sensor (APS)
A/F	: Air Fuel Mixture

B

BBDC	: Before Bottom Dead Center
BTDC	: Before Top Dead Center
B+	: Battery Positive Voltage

C

CKP Sensor	: Crankshaft Position Sensor (CKPS)
CKT	: Circuit
CLP Switch	: Clutch Lever Position Switch (Clutch Switch)
CMP Sensor	: Camshaft Position Sensor (CMPS)
CO	: Carbon Monoxide
CPU	: Central Processing Unit
CVT Control Unit	: Continuously Variable Transmission Control Unit

D

DC	: Direct Current
DMC	: Dealer Mode Coupler
DOHC	: Double Over Head Camshaft
DRL	: Daytime Running Light

E

ECM	: Engine Control Module Engine Control Unit (ECU) (FI Control Unit)
ECT Sensor	: Engine Coolant Temperature Sensor (ECTS), Water Temp. Sensor (WTS)
EVAP	: Evaporative Emission
EVAP Canister	: Evaporative Emission Canister (Canister)

F

FI	: Fuel Injection, Fuel Injector
FP	: Fuel Pump
FPR	: Fuel Pressure Regulator
FP Relay	: Fuel Pump Relay
FTPC Valve	: Fuel Tank Pressure Control Valve

G

GEN	: Generator
GND	: Ground
GP Switch	: Gear Position Switch

H

HC	: Hydrocarbons
HO2S	: Heated Oxygen Sensor

I

IAC Valve	: Idle Air Control Valve
IAP Sensor	: Intake Air Pressure Sensor (IAPS)
IAT Sensor	: Intake Air Temperature Sensor (IATS)
IG	: Ignition

L

LCD	: Liquid Crystal Display
LED	: Light Emitting Diode (Malfunction Indicator Lamp)
LH	: Left Hand

M

MAL-Code : Malfunction Code
(Diagnostic Code)
Max : Maximum
MIL : Malfunction Indicator Lamp
(LED)
Min : Minimum

N

NOx : Nitrogen Oxides

O

OHC : Over Head Camshaft
OLS : Oil Level Switch
OPS : Oil Pressure Switch

P

PCV : Positive Crankcase
Ventilation (Crankcase Breather)

R

RH : Right Hand
ROM : Read Only Memory

S

SAE : Society of Automotive Engineers

T

TO Sensor : Throttle Over Sensor (TOS)
TP Sensor : Throttle Position Sensor (TPS)

WIRE COLOR

B	: Black	G	: Green	P	: Pink
Bl	: Blue	Gr	: Gray	R	: Red
Br	: Brown	Lbl	: Light blue	V	: Violet
Dg	: Dark green	Lg	: Light green	W	: White
Dgr	: Dark gray	O	: Orange	Y	: Yellow

B/Bl	: Black with Blue tracer	B/Br	: Black with Brown tracer
B/G	: Black with Green tracer	B/O	: Black with Orange tracer
B/R	: Black with Red tracer	B/W	: Black with White tracer
B/Y	: Black with Yellow tracer	Bl/B	: Blue with Black tracer
Bl/G	: Blue with Green tracer	Bl/R	: Blue with Red tracer
Bl/W	: Blue with White tracer	Bl/Y	: Blue with Yellow tracer
Br/B	: Brown with Black tracer	Br/W	: Brown with White tracer
G/B	: Green with Black tracer	G/Bl	: Green with Blue tracer
G/R	: Green with Red tracer	G/W	: Green with White tracer
G/Y	: Green with Yellow tracer	Gr/B	: Gray with Black tracer
Gr/R	: Gray with Red tracer	Gr/W	: Gray with White tracer
Gr/Y	: Gray with Yellow tracer	Lg/B	: Light green with Black tracer
Lg/Y	: Light green with Yellow tracer	O/B	: Orange with Black tracer
O/Bl	: Orange with Blue tracer	O/G	: Orange with Green tracer
O/R	: Orange with Red tracer	O/W	: Orange with White tracer
O/Y	: Orange with Yellow tracer	P/B	: Pink with Black tracer
P/W	: Pink with White tracer	R/B	: Red with Black tracer
R/Bl	: Red with Blue tracer	R/G	: Red with Green tracer
R/W	: Red with White tracer	R/Y	: Red with Yellow tracer
W/B	: White with Black tracer	W/Bl	: White with Blue tracer
W/G	: White with Green tracer	W/R	: White with Red tracer
W/Y	: White with Yellow tracer	Y/B	: Yellow with Black tracer
Y/Bl	: Yellow with Blue tracer	Y/G	: Yellow with Green tracer
Y/R	: Yellow with Red tracer	Y/W	: Yellow with White tracer

GENERAL INFORMATION

1

CONTENTS

WARNING/ CAUTION/ NOTE	1- 2
GENERAL PRECAUTIONS	1- 2
SUZUKI AN650K3 ('03-MODEL)	1- 4
SERIAL NUMBER LOCATION	1- 4
FUEL, OIL AND ENGINE COOLANT RECOMMENDATION	1- 4
FUEL (FOR USA AND CANADA)	1- 4
FUEL (FOR OTHER COUNTRIES)	1- 4
ENGINE OIL AND TRANSMISSION OIL (FOR USA)	1- 5
ENGINE OIL AND TRANSMISSION OIL (FOR OTHER COUNTRIES)	1- 5
FINAL GEAR OIL	1- 5
BRAKE FLUID	1- 5
FRONT FORK OIL	1- 5
ENGINE COOLANT	1- 5
WATER FOR MIXING	1- 5
ANTI-FREEZE/ENGINE COOLANT	1- 5
LIQUID AMOUNT OF WATER/ENGINE COOLANT	1- 6
BREAK-IN PROCEDURES	1- 7
CYLINDER IDENTIFICATION	1- 7
INFORMATION LABELS	1- 8
SPECIFICATIONS	1- 9
COUNTRY AND AREA CODES	1-11

WARNING/ CAUTION/ NOTE

Please read this manual and follow its instructions carefully. To emphasize special information, the symbol and the words **WARNING**, **CAUTION** and **NOTE** have special meanings. Pay special attention to the messages highlighted by these signal words.

▲ WARNING

Indicates a potential hazard that could result in death or injury.

CAUTION

Indicates a potential hazard that could result in motorcycle damage.

NOTE:

Indicates special information to make maintenance easier or instructions clearer.

Please note, however, that the warnings and cautions contained in this manual cannot possibly cover all potential hazards relating to the servicing, or lack of servicing, of the motorcycle. In addition to the **WARNINGS** and **CAUTIONS** stated, you must use good judgement and basic mechanical safety principles. If you are unsure about how to perform a particular service operation, ask a more experienced mechanic for advice.

GENERAL PRECAUTIONS

▲ WARNING

- * Proper service and repair procedures are important for the safety of the service mechanic and the safety and reliability of the motorcycle.
- * When 2 or more persons work together, pay attention to the safety of each other.
- * When it is necessary to run the engine indoors, make sure that exhaust gas is forced outdoors.
- * When working with toxic or flammable materials, make sure that the area you work in is well-ventilated and that you follow all of the material manufacturer's instructions.
- * Never use gasoline as a cleaning solvent.
- * To avoid getting burned, do not touch the engine, engine oil, radiator and exhaust system until they have cooled.
- * After servicing the fuel, oil, water, exhaust or brake systems, check all lines and fittings related to the system for leaks.

CAUTION

- * If parts replacement is necessary, replace the parts with Suzuki Genuine Parts or their equivalent.
 - * When removing parts that are to be reused, keep them arranged in an orderly manner so that they may be reinstalled in the proper order and orientation.
 - * Be sure to use special tools when instructed.
 - * Make sure that all parts used in reassembly are clean. Lubricate them when specified.
 - * Use the specified lubricant, bond, or sealant.
 - * When removing the battery, disconnect the negative cable first and then the positive cable.
 - * When reconnecting the battery, connect the positive cable first and then the negative cable, and replace the terminal cover on the positive terminal.
 - * When performing service to electrical parts, if the service procedures not require use of battery power, disconnect the negative cable the battery.
 - * When tightening the cylinder head and case bolts and nuts, tighten the larger sizes first. Always tighten the bolts and nuts diagonally from the inside toward outside and to the specified tightening torque.
 - * Whenever you remove oil seals, gaskets, packing, O-rings, locking washers, self-locking nuts, cotter pins, circlips and certain other parts as specified, be sure to replace them with new ones. Also, before installing these new parts, be sure to remove any left over material from the mating surfaces.
 - * Never reuse a circlip. When installing a new circlip, take care not to expand the end gap larger than required to slip the circlip over the shaft. After installing a circlip, always ensure that it is completely seated in its groove and securely fitted.
 - * Use a torque wrench to tighten fasteners to the specified torque. Wipe off grease and oil if a thread is smeared with them.
 - * After reassembling, check parts for tightness and proper operation.
-
- * To protect the environment, do not unlawfully dispose of used motor oil, engine coolant and other fluids: batteries, and tires.
 - * To protect Earth's natural resources, properly dispose of used motorcycle and parts.

SUZUKI AN650K3 ('03-MODEL)

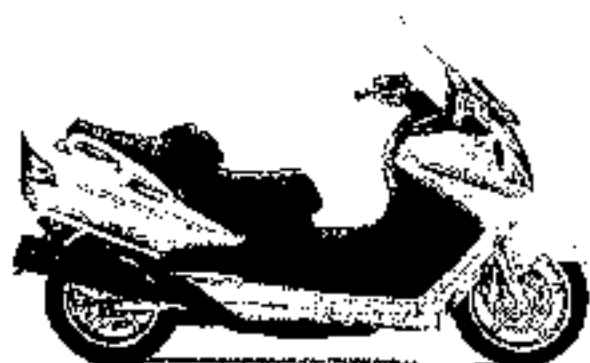

RIGHT SIDE



LEFT SIDE

* Differences between photographs and actual motorcycles depends on the markets.

SERIAL NUMBER LOCATION

The frame serial number or V.I.N. (Vehicle Identification Number) ① is stamped on the right side of the frame down tube. The engine serial number ② is located on the left side of the crankcase. These numbers are required especially for registering the machine and ordering spare parts.



FUEL, OIL AND ENGINE COOLANT RECOMMENDATION

FUEL (FOR USA AND CANADA)

Use only unleaded gasoline of at least 87 pump octane ($\frac{E.L.M.}{2}$) or 91 octane or higher rated by the research method.

Gasoline containing MTBE (Methyl Tertiary Butyl Ether), less than 10% ethanol, or less than 5% methanol with appropriate cosolvents and corrosion inhibitor is permissible.

FUEL (FOR OTHER COUNTRIES)

Gasoline used should be graded 91 octane (Research Method) or higher. Unleaded gasoline is recommended.

ENGINE OIL AND TRANSMISSION OIL (FOR USA)

SUZUKI recommends the use of SUZUKI PERFORMANCE 4 MOTOR OIL or an oil which is rated SF or SG under the API (American Petroleum Institute) service classification. The recommended viscosity is SAE 10W-40. If an SAE 10W-40 oil is not available, select an alternative according to the right chart.

ENGINE OIL AND TRANSMISSION OIL (FOR OTHER COUNTRIES)

Use a premium quality 4-stroke motor oil to ensure longer service life of your motorcycle. Use only oils which are rated SF or SG under the API service classification. The recommended viscosity is SAE 10W-40. If an SAE 10W-40 motor oil is not available, select an alternative according to the following chart.

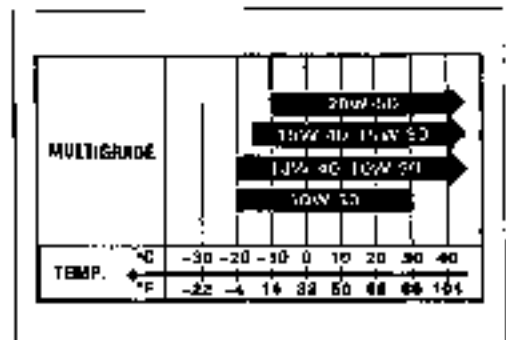

FINAL GEAR OIL

Use hypoid gear oil that meets the API service classification GL-5 and is rated SAE #90. Use a hypoid gear oil with a rating of SAE #80 if the motorcycle is operated where the ambient temperature is below 0 °C (32 °F).

BRAKE FLUID

Specification and classification: DOT 4

▲ WARNING

Since the brake system of this motorcycle is filled with a glycol-based brake fluid by the manufacturer, do not use or mix different types of fluid such as silicone-based and petroleum-based fluid for refilling the system, otherwise serious damage will result.

Do not use any brake fluid taken from old or used or unsealed containers.

Never re-use brake fluid left over from a previous servicing, which has been stored for a long period.

FRONT FORK OIL

Use fork oil #10 or an equivalent fork oil.

ENGINE COOLANT

Use an anti-freeze/engine coolant compatible with an aluminum radiator, mixed with distilled water only.

WATER FOR MIXING

Use distilled water only. Water other than distilled water can corrode and clog the aluminum radiator.

ANTI-FREEZE/ENGINE COOLANT

The engine coolant perform as a corrosion and rust inhibitor as well as anti-freeze. Therefore, the engine coolant should be used at all times even though the atmospheric temperature in your area does not go down to freezing point.

Suzuki recommends the use of SUZUKI COOLANT anti-freeze/engine coolant. If this is not available, use an equivalent which is compatible with an aluminum radiator.

LIQUID AMOUNT OF WATER/ENGINE COOLANT

Solution capacity (total): 1 300 ml (1.4/1.1 US/Imp qt)

For engine coolant mixture information, refer to cooling system section, page 8-3.

CAUTION

Mixing of anti-freeze/engine coolant should be limited to 60%. Mixing beyond it would reduce its efficiency. If the anti-freeze/engine coolant mixing ratio is below 50%, rust inhibiting performance is greatly reduced. Be sure to mix it above 50% even though the atmospheric temperature does not go down to the freezing point.

BREAK-IN PROCEDURES

During manufacture only the best possible materials are used and all machined parts are finished to a very high standard but it is still necessary to allow the moving parts to "BREAK-IN" before subjecting the engine to maximum stresses. The future performance and reliability of the engine depends on the care and restraint exercised during its early life. The general rules are as follows.

- Keep to these break-in engine speed limits:

Initial 800 km (500 miles): Below 4 000 r/min

Up to 1 600 km (1 000 miles): Below 6 000 r/min

Over 1 600 km (1 000 miles): Below 8 500 r/min

- Upon reaching an odometer reading of 1 600 km (1 000 miles) you can subject the motorcycle to full throttle operation. However, do not exceed 8 500 r/min at any time.

CYLINDER IDENTIFICATION

The two cylinders of this engine are identified as No.1 and No.2 cylinder, as counted from left to right (as viewed by the rider on the seat).

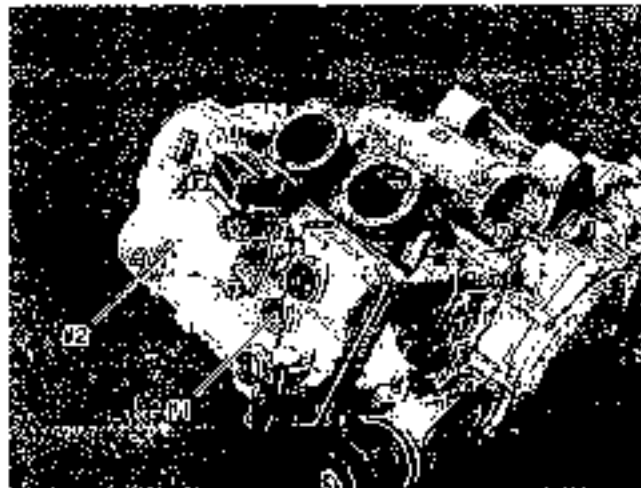

INFORMATION LABELS

①	Warning safety label (For E-02, 19, 24)
②	Engine starting label (For E-02, 19, 24)
③	Screen warning label (For E-02, 19, 24)
④	Tire pressure label (For E-02, 19, 24)
⑤	Fuel caution label (For E-02, 24)
⑥	Fuel indicator label (For F-02, 19, 24)
⑦	Front box loading capacity label (For E-02, 19, 24)
⑧	Trunk box loading capacity label (For E-02, 19, 24)
⑨	ID label (For E-02, 19, 24)
⑩	Noise label (For E-24)

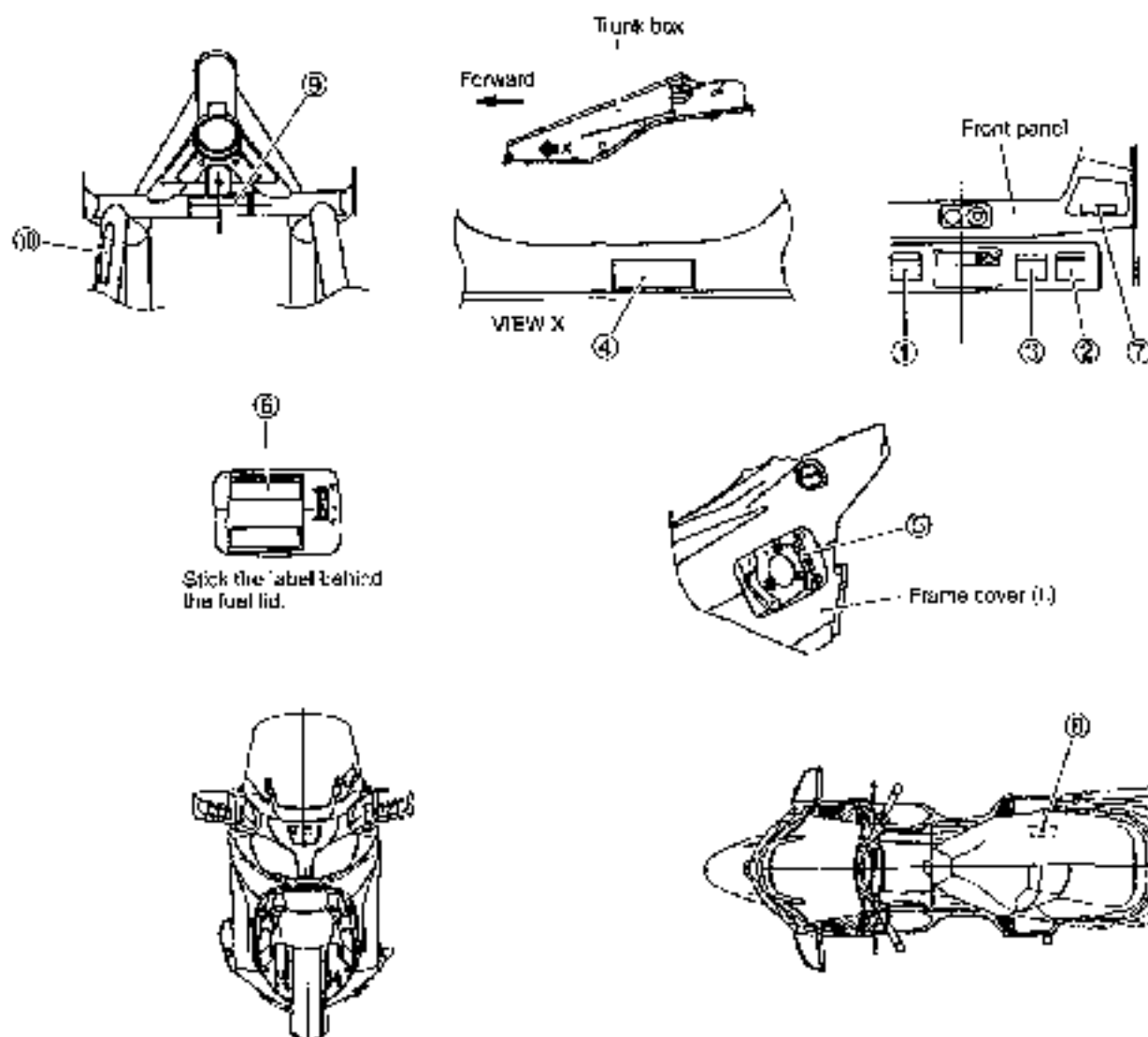

SPECIFICATIONS

DIMENSIONS AND DRY MASS

Overall length.....	2 280 mm (89.0 in)
Overall width.....	810 mm (31.9 in)
Overall height.....	1 430 mm (56.3 in)
Wheelbase.....	1 595 mm (62.8 in)
Ground clearance.....	125 mm (4.9 in)
Seat height.....	750 mm (29.5 in)
Dry mass.....	238 kg (394 lbs)

ENGINE

Type.....	Four-stroke, Liquid-cooled, DOHC
Number of cylinders.....	2
Bore.....	75.5 mm (2.972 in)
Stroke.....	71.3 mm (2.807 in)
Piston displacement.....	638 cm ³ (38.9 cu. in)
Compression ratio.....	11.2 : 1
Fuel system.....	Fuel injection system
Air cleaner.....	Non-woven fabric element
Starter system.....	Electric starter
Lubrication system.....	Wet sump

DRIVE TRAIN

Clutch.....	Wet multi-plate automatic, centrifugal type
Gearshift pattern.....	Automatic & Manual shift
Automatic transmission ratio.....	Variable change (1.800 – 0.465)
Final reduction ratio.....	1.580 (32/31 × 31/32 × 34/31 × 49/34)
Drive system.....	Gear drive

CHASSIS

Front suspension.....	Telescopic, coil spring, oil damped
Rear suspension.....	Swingarm type, coil spring, oil damped
Steering angle.....	41° (right & left)
Caster.....	26°
Trail.....	102 mm (4.0 in)
Turning radius.....	2.7 m (8.9 ft)
Front brake.....	Disc brake, twin
Rear brake.....	Disc brake
Front tire size.....	120/70 R15M/C 56H, tubeless
Rear tire size.....	160/60 R14M/C 65H, tubeless
Front fork stroke.....	105 mm (4.1 in)
Rear wheel travel.....	100 mm (3.9 in)

ELECTRICAL

Ignition type.....	Electronic ignition (ECM, Transistorized)
Ignition timing.....	10° B. I. D. C at 1 200 r/min
Spark plug.....	NGK CH8E or DENSO: U24ESR-N
Battery.....	12 V 43.2 kC (12 Ah)/10 HR
Generator.....	Three-phase A.C. Generator
Main fuse.....	40 A
CVT fuse.....	40 A
Fuse.....	15/15/15/15/10/10/10 A
Headlight.....	12 V 60/55 W + 55 W (H4 + H7) E-02, 19 12 V 60/55W x 2 (H4) E-03, 24, 28, 33
Position light.....	12 V 5 W x 2 E-02, 19
Turn signal light.....	12 V 21 W
License light.....	12 V 5 W
Brake light/Tail light.....	12 V 21/5 W x 2
Speedometer light.....	12 V 1.4 W x 2
Power mode indicator light.....	12 V 1.4 W
Drive indicator light.....	12 V 1.4 W
High beam indicator light.....	12 V 1.4 W
Turn signal indicator light.....	12 V 1.4 W
Brake lock indicator light.....	12 V 1.4 W
Fuel injector indicator light.....	12 V 1.4 W
Engine coolant temperature indicator light.....	12 V 1.4 W
Oil pressure indicator light.....	12 V 1.4 W
Gear position indicator light.....	12 V 1.4 W x 5

CAPACITIES

Fuel tank, including reserve.....	15.0 L (4.0/3.3 US/imp gal)
Engine oil, oil change.....	2 600 ml (2.7/2.3 US/imp qt)
with filter change.....	2 900 ml (3.1/2.6 US/imp qt)
overhaul.....	3 400 ml (3.6/3.0 US/imp qt)
Transmission oil, oil change.....	360 ml (12.2/12.7 US/imp oz)
overhaul.....	400 ml (13.5/14.1 US/imp oz)
Final gear oil, oil change.....	300 ml (10.1/10.6 US/imp oz)
overhaul.....	430 ml (14.5/15.1 US/imp oz)
Engine coolant, including reserve.....	1 300 ml (1.4/1.1 US/imp qt)
Front fork oil (each leg).....	482 ml (16.3/17.0 US/imp oz)

These specifications are subject to change without notice.

COUNTRY AND AREA CODES

The following codes stand for the applicable country(-ies) and area(-s).

CODE	COUNTRY or AREA
E-02	U. K.
E-03	U. S. A. (Except for California)
E-19	EU
E-24	Australia
E-28	Canada
E-33	California (U. S. A.)

PERIODIC MAINTENANCE

CONTENTS

PERIODIC MAINTENANCE SCHEDULE	2- 2
PERIODIC MAINTENANCE CHART	2- 2
LUBRICATION POINTS	2- 3
MAINTENANCE AND TUNE-UP PROCEDURES	2- 4
AIR CLEANER	2- 4
SPARK PLUG	2- 6
TAPPET CLEARANCE	2- 7
FUEL HOSE	2-13
ENGINE OIL AND OIL FILTER	2-13
TRANSMISSION OIL	2-15
FINAL GEAR OIL	2-15
CVT FILTER	2-16
ENGINE IDLE SPEED	2-18
THROTTLE CABLE PLAY	2-18
THROTTLE VALVE SYNCHRONIZATION	2-19
PAIR (AIR SUPPLY) SYSTEM	2-19
COOLING SYSTEM	2-20
BRAKE	2-22
TIRE	2-25
STEERING	2-26
FRONT FORK	2-26
REAR SUSPENSION	2-27
EXHAUST PIPE BOLT AND MUFFLER MOUNTING BOLT	2-27
CHASSIS BOLT AND NUT	2-28
COMPRESSION PRESSURE CHECK	2-30
COMPRESSION TEST PROCEDURE	2-30
OIL PRESSURE CHECK	2-31
OIL PRESSURE TEST PROCEDURE	2-31
AUTOMATIC CLUTCH INSPECTION	2-32
1. INITIAL ENGAGEMENT INSPECTION	2-32
2. CLUTCH "LOCK-UP" INSPECTION	2-32
BRAKE-LOCK INSPECTION	2-33

PERIODIC MAINTENANCE SCHEDULE

The chart below lists the recommended intervals for all the required periodic service work necessary to keep the motorcycle operating at peak performance and economy. Mileages are expressed in terms of kilometers, miles and time for your convenience.

NOTE:

More frequent servicing may be performed on motorcycles that are used under severe conditions.

PERIODIC MAINTENANCE CHART

Item	Interval	km	1 000	6 000	12 000	18 000	24 000
		miles	600	4 000	7 500	11 000	14 500
		months	1	6	12	18	24
Air cleaner		—	I	I	R	I	I
Exhaust pipe bolts and muffler bolts		T	—	T	—	—	T
Tapet clearance		—	—	—	—	—	I
Spark plugs		—	—	I	R	I	R
Fuel hose		—	—	I	I	I	I
			Replace every 4 years				
Engine oil		—	R	R	R	R	R
Engine oil filter		—	R	—	—	R	—
Transmission oil		—	R	I	R	I	R
Final gear oil		—	R	—	R	—	R
CVT filter		—	—	—	I	—	I
Idle speed		—	I	I	I	I	I
Throttle cable play		—	I	I	I	I	I
Throttle valve synchronization		—	I	—	I	—	I
			E-33 only				
Evaporative emission control system E-33 (California) model only		—	—	—	I	—	I
			Replace vapor hose every 4 years.				
PAIR (air supply) system		—	—	—	I	—	I
Engine coolant		—	—	—	—	—	—
			Replace every 2 years.				
Radiator hose		—	—	—	I	—	I
Brakes		—	I	I	I	I	I
Brake hose		—	—	—	—	—	—
			Replace every 4 years.				
Brake fluid		—	—	—	I	—	I
			Replace every 2 years.				
Tires		—	—	I	I	I	I
Steering		—	I	—	—	—	I
Front forks		—	—	—	I	—	I
Rear suspension		—	—	—	I	—	I
Chassis bolts and nuts		T	T	T	T	T	T

NOTE:

I=Inspect and clean, adjust, replace or lubricate as necessary;

R=Replace; T=Tighten

LUBRICATION POINTS

Proper lubrication is important for smooth operation and long life of each working part of the motorcycle. Major lubrication points are indicated below.

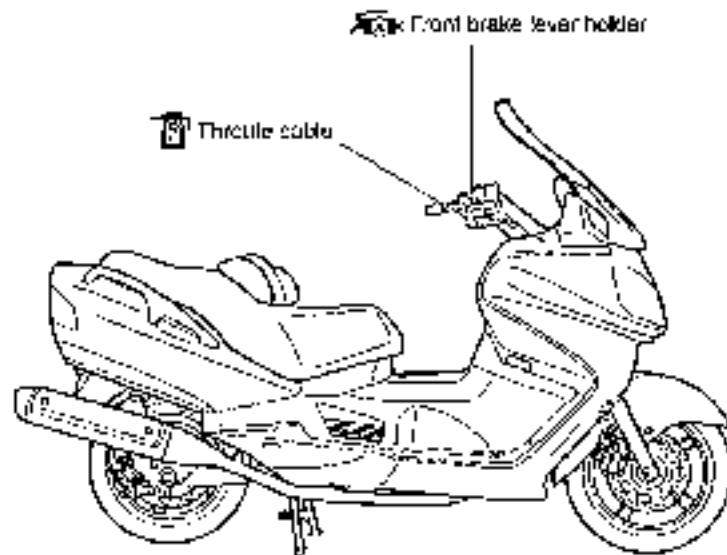
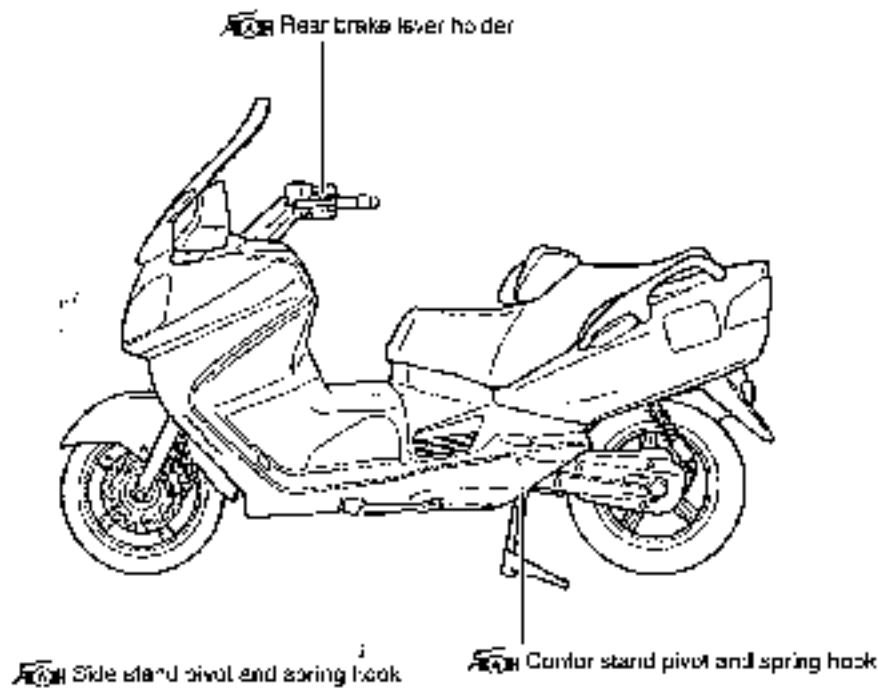

NOTE:

- Before lubricating each part, clean off any rusty spots and wipe off any grease, oil, dirt or grime.
- Lubricate exposed parts which are subject to rust, with a rust preventative spray whenever the motorcycle has been operated under wet or rainy conditions.

MAINTENANCE AND TUNE-UP PROCEDURES

This section describes the servicing procedures for each item of the Periodic Maintenance requirements.

AIR CLEANER

Inspect every 8 000 km (4 000 miles, 6 months) and replace every 18 000 km (11 000 miles, 18 months).

- Open the front box (1).
- Remove the air cleaner box lid (2).
- Remove the air cleaner element lid (3).

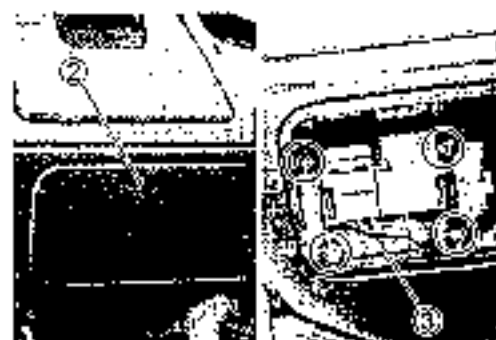

- Remove the air cleaner element (4).



- Inspect the air cleaner element and O-ring for damage. If any defects are found, the air cleaner element and O-ring must be replaced.



- Carefully use air hose to blow the dust from the cleaner element.

CAUTION

Always use air pressure on the throttle body side of the air cleaner element. If air pressure is used on the other side, dirt will be forced into the pores of the air cleaner element thus restricting air flow through the air cleaner element.

- Install the O-ring (5) properly.
- Reinstall the cleaned or new air cleaner element in the reverse order of removal.

CAUTION

If driving under dusty condition, clean the air cleaner element more frequently. The surest way to accelerate engine wear is to use the engine without the element or to use a ruptured element. Make sure that the air cleaner is in good condition at all times. Life of the engine depends largely on this component!

NOTE:

When cleaning the air cleaner element, drain water from the air cleaner by removing the drain plug.



SPARK PLUG

Inspect every 6 000 km (4 000 miles, 6 months) and replace every 12 000 km (7 500 miles, 12 months).

SPARK PLUG REMOVAL

- Remove the lower leg shield. (C79 10)
- Remove the bolt.
- Move the radiator ① forward.

NOTE:

Be careful not to damage the radiator fins.

⚠ WARNING

The hot radiator and the hot engine can burn you. Wait until the radiator and the engine are cool enough to touch.

- Remove the ignition coil/plug caps ②.

- Remove the spark plugs with the spark plug wrench.

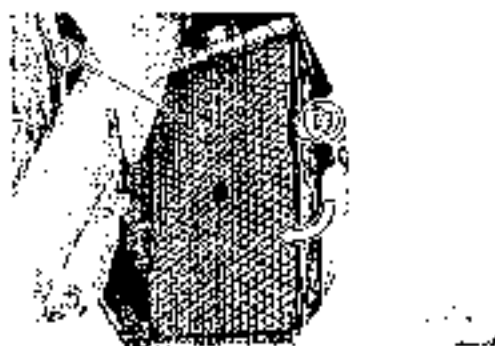

HEAT RANGE

- Check to see the heat range of the plug.

	Standard	Cold type	Hot type
NGK	CR8E	CR9F	CR7E
DENSO	U24ESR-N	U27ESR-N	U22ESR N

CARBON DEPOSIT

- Check to see if there are carbons deposit on the plugs. If carbon is deposited, remove it with a spark plug cleaner machine or carefully using a tool with a pointed end.

SPARK PLUG GAP

- Measure the plug gap with a thickness gauge. If out of specification, adjust it to the following gap.

 09900-20803: Thickness gauge

DATA Spark plug gap

Standard: 0.7 – 0.8 mm (0.028 – 0.031 in)

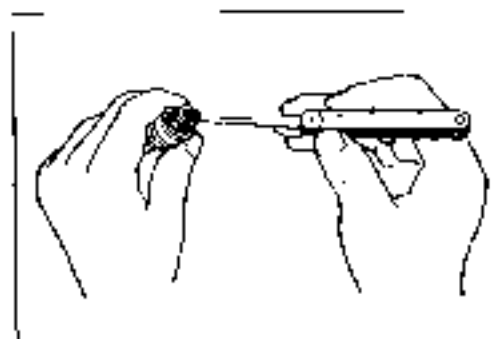
**ELECTRODES CONDITION**

- Check to see the worn or burnt condition of the electrodes. If it is extremely worn or burnt, replace the plug. And also replace the plug if it has a broken insulator, damaged thread.

CAUTION

Confirm the thread size and reach when replacing the plug. If the reach is too short, carbon will be deposited on the screw portion of the plug hole and engine damage may result.

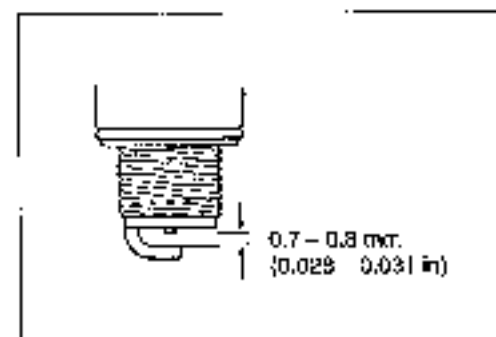
**SPARK PLUG INSTALLATION****CAUTION**

Before tightening the spark plug to the specified torque, carefully turn the spark plug by finger into the threads of the cylinder head to prevent damage the aluminum threads.

- Install the spark plugs to the cylinder heads by finger tight, and then tighten them to the specified torque.

 Spark plug: 11 N·m (1.1 kgf·m, 8.0 lb·ft)

**TAPPET CLEARANCE**

Inspect every 24 000 km (14 500 miles, 24 months).

- Remove the front fax. (C79-18)
- Remove the foot board. (C79-18)
- Remove the radiator. (C78-6)
- Remove the spark plugs. (C72-6)
- Remove the cylinder head cover ①.



The tappet clearance specification is different for intake and exhaust valves. Tappet clearance must be checked and adjusted, 1) at the time of periodic inspection, 2) when the valve mechanism is serviced, and 3) when the camshafts are removed for servicing.

DATA Tappet clearance (when cold):

Standard: IN. : 0.10 - 0.20 mm (0.004 - 0.008 in)

EX. : 0.20 - 0.30 mm (0.008 - 0.012 in)

NOTE:

- * The clearance specification is for COLD state.
- * To turn the crankshaft for clearance checking, be sure to use a wrench, and rotate in the normal running direction. All spark plugs should be removed.
- Remove the valve timing inspection cap (2).



- Turn the crankshaft to bring the "Top" line on the starter clutch to the index mark and also to align the notches (A) on the both ends of each camshafts with "1" mark (B) on the exhaust sprocket to the positions as shown.

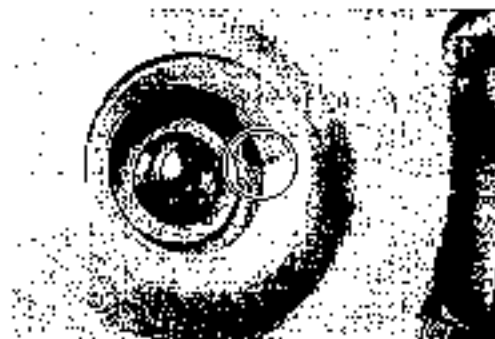

- In this condition, read the tappet clearance at the valves (In and Ex of No.2).
- If the clearance is out of specification, adjust the clearance as shown below.

 09900-20803: Thickness gauge

- Turn the crankshaft 360 degrees (one rotation) to bring the "TOP" line on the starter clutch to the index mark of valve timing inspection hole and also to bring notches (X) to the position as shown.
- Read the clearance at the remaining valves (In and Ex of No.1) and adjust the clearance if necessary as shown below.



TAPPET CLEARANCE ADJUSTMENT

The clearance is adjusted by replacing the existing tappet shim by a thicker or thinner shim.

- Remove the intake or exhaust camshaft. (C-7-12)
- Remove the tappet (1) and shim (2) by fingers or magnetic hand.
- Check the figures printed on the shim. These figures indicate the thickness of the shim, as illustrated.
- Select a replacement shim that will provide a clearance within the specified range. For the purpose of this adjustment, a total of 25 sizes of tappet shim are available ranging from 1.20 to 2.20 mm in steps of 0.05 mm. Fit the selected shim to the valve stem end, with numbers toward tappet. Be sure to check shim size with micrometer to ensure its size. Refer to the tappet shim selection table (Pages 2-11 and 2-12) for details.



NOTE:

- Be sure to apply engine oil to tappet shim top and bottom faces.
- When seating the tappet shim, be sure to face figure printed surface to the tappet.

CAUTION

Reinstall the camshafts as the specified manner.
(CMP 3-72)

- After replacing the tappet shim and camshafts, rotate the engine so that the tappet is depressed fully. This will squeeze out oil trapped between the shim and the tappet that could cause an incorrect measurement, then check the clearance again to confirm that it is within the specified range.
- After finishing the valve clearance adjustment, reinstall the following items

	Page
• Cylinder head cover	3-74
• Spark plug and plug cap	2-6
• Valve timing inspection plug	2-8

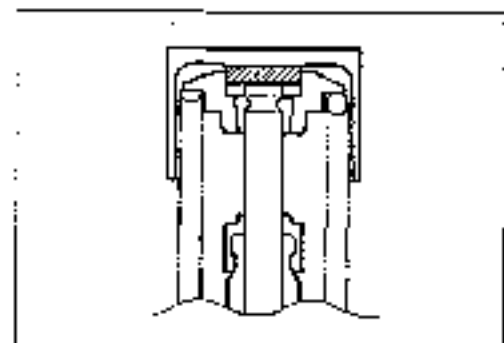
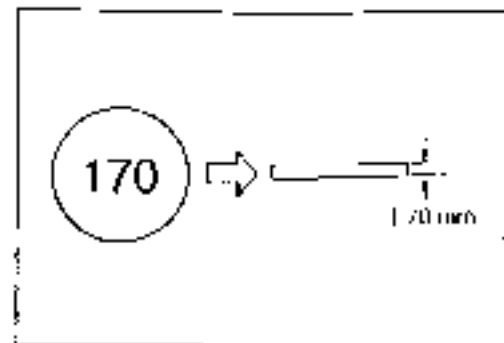

(INTAKE SIDE)

TAPPET SHIM SELECTION TABLE (INTAKE)
TAPPET SHIM NO. (12692-05C00-XXX)

TAPPET SHIM SET (12800-05B20)

MEASURED TAPPET CLEARANCE (mm)	SPECIFIED CLEARANCE (mm) EQUIPPED																			
	120	125	130	135	140	145	150	155	160	165	170	175	180	185	190	195	200	205	210	220
0.00-0.04	1.20	1.25	1.30	1.35	1.40	1.45	1.50	1.55	1.60	1.65	1.70	1.75	1.80	1.85	1.90	1.95	2.00	2.05	2.10	2.20
0.05-0.09	1.30	1.35	1.40	1.45	1.50	1.55	1.60	1.65	1.70	1.75	1.80	1.85	1.90	1.95	2.00	2.05	2.10	2.15	2.20	2.30
0.10-0.14	1.40	1.45	1.50	1.55	1.60	1.65	1.70	1.75	1.80	1.85	1.90	1.95	2.00	2.05	2.10	2.15	2.20	2.25	2.30	2.40
0.15-0.19	1.50	1.55	1.60	1.65	1.70	1.75	1.80	1.85	1.90	1.95	2.00	2.05	2.10	2.15	2.20	2.25	2.30	2.35	2.40	2.50
0.20-0.24	1.60	1.65	1.70	1.75	1.80	1.85	1.90	1.95	2.00	2.05	2.10	2.15	2.20	2.25	2.30	2.35	2.40	2.45	2.50	2.60
0.25-0.29	1.70	1.75	1.80	1.85	1.90	1.95	2.00	2.05	2.10	2.15	2.20	2.25	2.30	2.35	2.40	2.45	2.50	2.55	2.60	2.70
0.30-0.34	1.80	1.85	1.90	1.95	2.00	2.05	2.10	2.15	2.20	2.25	2.30	2.35	2.40	2.45	2.50	2.55	2.60	2.65	2.70	2.80
0.35-0.39	1.90	1.95	2.00	2.05	2.10	2.15	2.20	2.25	2.30	2.35	2.40	2.45	2.50	2.55	2.60	2.65	2.70	2.75	2.80	2.90
0.40-0.44	2.00	2.05	2.10	2.15	2.20	2.25	2.30	2.35	2.40	2.45	2.50	2.55	2.60	2.65	2.70	2.75	2.80	2.85	2.90	3.00
0.45-0.49	2.10	2.15	2.20	2.25	2.30	2.35	2.40	2.45	2.50	2.55	2.60	2.65	2.70	2.75	2.80	2.85	2.90	2.95	3.00	3.10
0.50-0.54	2.20	2.25	2.30	2.35	2.40	2.45	2.50	2.55	2.60	2.65	2.70	2.75	2.80	2.85	2.90	2.95	3.00	3.05	3.10	3.20
0.55-0.59	2.30	2.35	2.40	2.45	2.50	2.55	2.60	2.65	2.70	2.75	2.80	2.85	2.90	2.95	3.00	3.05	3.10	3.15	3.20	3.30
0.60-0.64	2.40	2.45	2.50	2.55	2.60	2.65	2.70	2.75	2.80	2.85	2.90	2.95	3.00	3.05	3.10	3.15	3.20	3.25	3.30	3.40
0.65-0.69	2.50	2.55	2.60	2.65	2.70	2.75	2.80	2.85	2.90	2.95	3.00	3.05	3.10	3.15	3.20	3.25	3.30	3.35	3.40	3.50
0.70-0.74	2.60	2.65	2.70	2.75	2.80	2.85	2.90	2.95	3.00	3.05	3.10	3.15	3.20	3.25	3.30	3.35	3.40	3.45	3.50	3.60
0.75-0.79	2.70	2.75	2.80	2.85	2.90	2.95	3.00	3.05	3.10	3.15	3.20	3.25	3.30	3.35	3.40	3.45	3.50	3.55	3.60	3.70
0.80-0.84	2.80	2.85	2.90	2.95	3.00	3.05	3.10	3.15	3.20	3.25	3.30	3.35	3.40	3.45	3.50	3.55	3.60	3.65	3.70	3.80
0.85-0.89	2.90	2.95	3.00	3.05	3.10	3.15	3.20	3.25	3.30	3.35	3.40	3.45	3.50	3.55	3.60	3.65	3.70	3.75	3.80	3.90
0.90-0.94	3.00	3.05	3.10	3.15	3.20	3.25	3.30	3.35	3.40	3.45	3.50	3.55	3.60	3.65	3.70	3.75	3.80	3.85	3.90	4.00
0.95-0.99	3.10	3.15	3.20	3.25	3.30	3.35	3.40	3.45	3.50	3.55	3.60	3.65	3.70	3.75	3.80	3.85	3.90	3.95	4.00	4.10
1.00-1.04	3.20	3.25	3.30	3.35	3.40	3.45	3.50	3.55	3.60	3.65	3.70	3.75	3.80	3.85	3.90	3.95	4.00	4.05	4.10	4.20
1.05-1.09	3.30	3.35	3.40	3.45	3.50	3.55	3.60	3.65	3.70	3.75	3.80	3.85	3.90	3.95	4.00	4.05	4.10	4.15	4.20	4.30
1.10-1.14	3.40	3.45	3.50	3.55	3.60	3.65	3.70	3.75	3.80	3.85	3.90	3.95	4.00	4.05	4.10	4.15	4.20	4.25	4.30	4.40

HOW TO USE THIS CHART:

- I. Measure tappet clearance: "ENGINE IS COLD"
- II. Measure present shim size.
- III. Match clearance in vertical column with present shim size in horizontal column.

EXAMPLE

Tappet clearance is 0.25 mm
Present shim size 1.70 mm
Shim size to be used 1.80 mm

(EXHAUST SIDE)

TAPPET SHIM SELECTION TABLE (EXHAUST)
TAPPET SHIM NO. (12892-05C00-XXX)

		TAPPET SHIM S.E.T. (12600-0S622)																				
MEASURED TAPPET CLEARANCE (mm)	SUPPORT NO	120	125	130	135	140	145	150	155	160	165	170	175	180	185	190	195	200	205	210	215	220
		PRESENT SHIM SIZE (mm)	1.23	1.25	1.28	1.35	1.40	1.45	1.50	1.55	1.60	1.65	1.70	1.75	1.80	1.85	1.90	1.95	2.00	2.05	2.10	2.15
0.30-0.39				1.23	1.25	1.31	1.35	1.40	1.45	1.50	1.55	1.60	1.65	1.70	1.75	1.80	1.85	1.90	1.95	2.00	2.05	2.10
0.10-0.14				1.25	1.25	1.30	1.35	1.40	1.45	1.50	1.55	1.60	1.65	1.70	1.75	1.80	1.85	1.90	1.95	2.00	2.05	2.10
0.15-0.19				1.25	1.25	1.30	1.35	1.40	1.45	1.50	1.55	1.60	1.65	1.70	1.75	1.80	1.85	1.90	1.95	2.00	2.05	2.10
0.20-0.30				1.25	1.25	1.30	1.35	1.40	1.45	1.50	1.55	1.60	1.65	1.70	1.75	1.80	1.85	1.90	1.95	2.00	2.05	2.10
0.31-0.35				1.25	1.25	1.30	1.35	1.40	1.45	1.50	1.55	1.60	1.65	1.70	1.75	1.80	1.85	1.90	1.95	2.00	2.05	2.10
0.36-0.40				1.25	1.25	1.30	1.35	1.40	1.45	1.50	1.55	1.60	1.65	1.70	1.75	1.80	1.85	1.90	1.95	2.00	2.05	2.10
0.41-0.45				1.25	1.25	1.30	1.35	1.40	1.45	1.50	1.55	1.60	1.65	1.70	1.75	1.80	1.85	1.90	1.95	2.00	2.05	2.10
0.46-0.50				1.25	1.25	1.30	1.35	1.40	1.45	1.50	1.55	1.60	1.65	1.70	1.75	1.80	1.85	1.90	1.95	2.00	2.05	2.10
0.51-0.55				1.25	1.25	1.30	1.35	1.40	1.45	1.50	1.55	1.60	1.65	1.70	1.75	1.80	1.85	1.90	1.95	2.00	2.05	2.10
0.56-0.60				1.25	1.25	1.30	1.35	1.40	1.45	1.50	1.55	1.60	1.65	1.70	1.75	1.80	1.85	1.90	1.95	2.00	2.05	2.10
0.61-0.65				1.25	1.25	1.30	1.35	1.40	1.45	1.50	1.55	1.60	1.65	1.70	1.75	1.80	1.85	1.90	1.95	2.00	2.05	2.10
0.66-0.70				1.25	1.25	1.30	1.35	1.40	1.45	1.50	1.55	1.60	1.65	1.70	1.75	1.80	1.85	1.90	1.95	2.00	2.05	2.10
0.71-0.75				1.25	1.25	1.30	1.35	1.40	1.45	1.50	1.55	1.60	1.65	1.70	1.75	1.80	1.85	1.90	1.95	2.00	2.05	2.10
0.76-0.80				1.25	1.25	1.30	1.35	1.40	1.45	1.50	1.55	1.60	1.65	1.70	1.75	1.80	1.85	1.90	1.95	2.00	2.05	2.10
0.81-0.85				1.25	1.25	1.30	1.35	1.40	1.45	1.50	1.55	1.60	1.65	1.70	1.75	1.80	1.85	1.90	1.95	2.00	2.05	2.10
0.86-0.90				1.25	1.25	1.30	1.35	1.40	1.45	1.50	1.55	1.60	1.65	1.70	1.75	1.80	1.85	1.90	1.95	2.00	2.05	2.10
0.91-0.95				1.25	1.25	1.30	1.35	1.40	1.45	1.50	1.55	1.60	1.65	1.70	1.75	1.80	1.85	1.90	1.95	2.00	2.05	2.10
0.96-1.00				1.25	1.25	1.30	1.35	1.40	1.45	1.50	1.55	1.60	1.65	1.70	1.75	1.80	1.85	1.90	1.95	2.00	2.05	2.10
1.01-1.05				1.25	1.25	1.30	1.35	1.40	1.45	1.50	1.55	1.60	1.65	1.70	1.75	1.80	1.85	1.90	1.95	2.00	2.05	2.10
1.06-1.10				1.25	1.25	1.30	1.35	1.40	1.45	1.50	1.55	1.60	1.65	1.70	1.75	1.80	1.85	1.90	1.95	2.00	2.05	2.10
1.11-1.15				1.25	1.25	1.30	1.35	1.40	1.45	1.50	1.55	1.60	1.65	1.70	1.75	1.80	1.85	1.90	1.95	2.00	2.05	2.10
1.16-1.20				1.25	1.25	1.30	1.35	1.40	1.45	1.50	1.55	1.60	1.65	1.70	1.75	1.80	1.85	1.90	1.95	2.00	2.05	2.10
0.21-1.25				1.25	1.25	1.30	1.35	1.40	1.45	1.50	1.55	1.60	1.65	1.70	1.75	1.80	1.85	1.90	1.95	2.00	2.05	2.10

HOW TO USE THIS CHART:
 I. Measure tappet clearance "ENGINE IS COLD"
 II. Measure present shim size
 III. Match clearance in vertical column with present shim size in horizontal column.

EXAMPLE
 Tappet clearance is 0.33 mm
 Present shim size 1.70 mm
 Shim size to be used 1.80 mm

FUEL HOSE

Inspect every 6 000 km (4 000 miles, 6 months).
Replace every 4 years.

Inspect the fuel feed hose ④ for damage and fuel leakage. If any defects are found, the fuel hoses must be replaced.



ENGINE OIL AND OIL FILTER

(ENGINE OIL)

Replace initially at 1 000 km (600 miles, 1 month) and every 6 000 km (4 000 miles, 6 months) thereafter.

(OIL FILTER)

Replace initially at 1 000 km (600 miles, 1 month) and every 18 000 km (11 000 miles, 18 months) thereafter.

Oil should be changed while the engine is warm. Oil filter replacement at the above intervals, should be done together with the engine oil change.

ENGINE OIL REPLACEMENT

- Keep the motorcycle upright with the center stand.
 - Remove the maintenance lid. (C-9-13)
 - Place an oil pan below the engine, and drain oil by removing the drain plug ① and filler cap ②.
 - Tighten the drain plug ① to the specified torque, and pour fresh oil through the oil filler. The engine will hold about 2.6 L (2.7/2.3 US/Imp qt) of oil. Use an API classification of SF or SG oil with SAE 10W-40 viscosity.
- ⓘ Oil drain plug: 23 N·m (2.3 kg·m, 16.5 lb-ft)**



- Start the engine and allow it to run for three minutes at idling speed.
- Turn off the engine and wait about three minutes, then check the oil level through the inspection window (6). If the level is below mark "L", add oil to "F" level. If the level is above mark "F", drain oil to "F" level.

OIL FILTER REPLACEMENT

- Drain engine oil in the same manner of engine oil replacement procedure.
- Remove the oil filter (3) by using the oil filter wrench. (Special tool)
- Apply engine oil lightly to the gasket of the new filter before installation.
- Install the new filter turning it by hand until you feel that the filter gasket contacts the mounting surface. Then tighten it 2 turns using the oil filter wrench.

TOOL 09915-40610: Oil filter wrench

NOTE

To properly tighten the filter, use the special tool. Never tighten the filter by hand.

- Pour fresh engine oil and check the oil level in the same manner of engine oil replacement procedure.

DATA Engine oil capacity

Oil change:	2.6 L (2.7/2.3 US/Imp qt)
Filter change:	2.9 L (3.1/2.6 US/Imp qt)
Overhaul engine:	3.4 L (3.6/3.0 US/Imp qt)

CAUTION

ONLY USE A GENUINE SUZUKI MOTORCYCLE OIL FILTER. Other manufacturer's oil filters may differ in thread specifications (thread diameter and pitch), filtering performance and durability which may lead to engine damage or oil leaks. Also, do not use a genuine Suzuki automobile oil filter on this motorcycle.

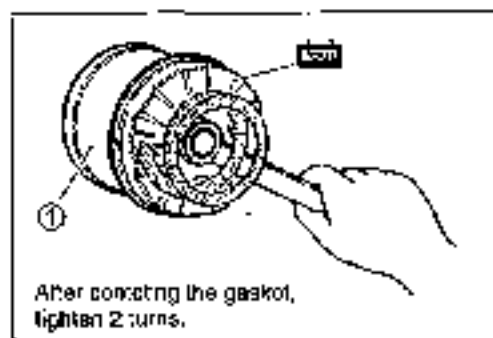

TRANSMISSION OIL

Replace initially at 1 000 km (600 miles, 1 month) and every 12 000 km (7 500 miles, 12 months) thereafter. Inspect every 6 000 km (4 000 miles, 8 months) thereafter.

TRANSMISSION OIL REPLACEMENT

- Keep the motorcycle upright with the center stand.
- Place an oil pan below the mission case.
- Remove the oil drain plug ① and filler plug ②.
- Tighten the drain plug ① to the specified torque, and pour fresh oil through the oil filler.
- Remove the oil level plug ③ and inspect the oil level. If the level is below the level hole, add oil until oil flows from the level hole.

Oil viscosity and classification

: SAE 10 W-40 with API SF or SG

- Tighten the oil level plug ③ and filler plug ② to the specified torque.

 Oil level plug: 12 N·m (1.2 kgf-m, 8.5 lb-ft)

Drain plug: 12 N·m (1.2 kgf-m, 8.5 lb-ft)

Oil filler plug: 12 N·m (1.2 kgf-m, 8.5 lb-ft)

DATA NECESSARY AMOUNT OF TRANSMISSION OIL

Oil change: 360 ml (12.2/12.7 US/Imp oz)

Overhaul: 400 ml (13.5/14.1 US/Imp oz)

FINAL GEAR OIL

Replace initially at 1 000 km (600 miles, 1 month) and every 12 000 km (7 500 miles, 12 months) thereafter.

FINAL GEAR OIL REPLACEMENT

- Keep the motorcycle upright with the center stand.
- Remove the final gear case cover ①.
- Place an oil pan below the final gear case.

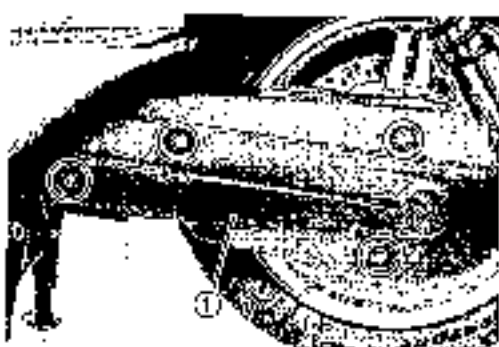

- Remove the oil drain plug (2) and oil level plug (3).
- Tighten the oil drain plug (2) to the specified torque, and pour fresh oil through the oil level hole until the oil over flows from the oil level hole.

🔧 Drain plug: 33 N·m (3.3 kgf-m, 24.0 lb-ft)

- Tighten the oil level plug (3) to the specified torque.

🔧 Oil level plug: 33 N·m (3.3 kgf-m, 24.0 lb-ft)

📖 Oil viscosity and classification

: Hypoid gear oil SAE #90 API grade GL-5

DATA NECESSARY AMOUNT OF FINAL GEAR OIL

Oil change: 300 ml (10.1/10.6 US/Imp oz)

Overhaul: 430 ml (14.5/15.1 US/Imp oz)



CVT FILTER

Inspect every 12 000 km (7 500 miles, 12 months) and replace every 18 000 km (11 000 miles, 18 months).

- Remove the leg side cover. (L 9-12)
- Remove the CVT filter lid (1).

⚠️ hooked part



- Remove the CVT filter cover (2).

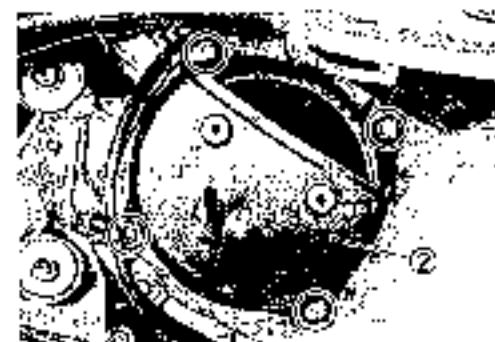

- Remove the CVT filter (3).

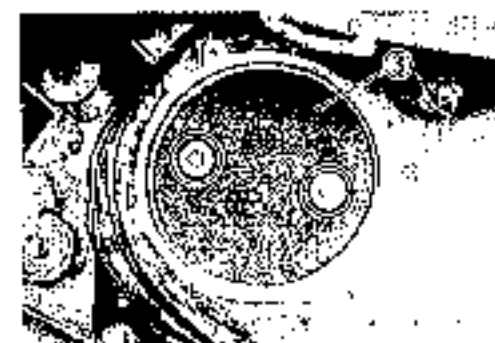

- Inspect the CVT filter for damage and dirt. If any defects are found, the CVT filter must be replaced.

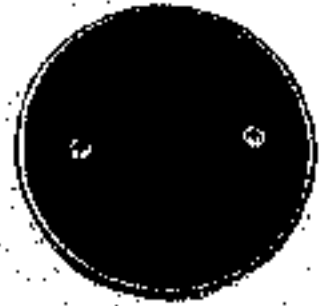

ENGINE IDLE SPEED

Inspect initially at 1 000 km (600 miles, 1 month) and every 6 000 km (4 000 miles, 6 months) thereafter.

NOTE:

Make this adjustment when the engine is hot.

- Remove the maintenance lid. (7-9-13)
- Start the engine and set its idle speed to the specified range by turning the throttle stop screw (A).

DATA Engine idle speed: 1 200 ± 100 r/min

THROTTLE CABLE PLAY

Inspect initially at 1 000 km (600 miles, 1 month) and every 6 000 km (4 000 miles, 6 months) thereafter.

Adjust the throttle cable play (A) with the following three steps.

MINOR ADJUSTMENT

First step

- Loosen the locknut (3) of the throttle returning cable (1) and turn in the adjuster (4) fully into the threads.

Second step:

- Loosen the locknut (5) of the throttle pulling cable (2).
- Turn the adjuster (6) in or out until the throttle cable play (A) should be 2.0 – 4.0 mm (0.08 – 0.16 in) at the throttle grip.
- Tighten the locknut (5) while holding the adjuster (6).

Third step:

- While holding the throttle grip at the fully closed position, slowly turn out the adjuster (4) of the throttle returning cable (1) to feel resistance.
- Tighten the locknut (3) while holding the adjuster (4)

DATA Throttle cable play (A): 2.0 – 4.0 mm (0.08 – 0.16 in)

⚠ WARNING

After the adjustment is completed, check that handle-bar movement does not raise the engine idle speed and that the throttle grip returns smoothly and automatically.

NOTE:

Major adjustment can be made by the throttle body side adjuster.

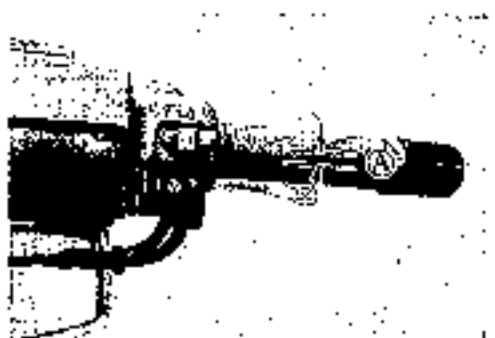

MAJOR ADJUSTMENT

- Remove the front box. (C-7-9-18)
- Loosen the locknut ① of the throttle returning cable ②.
- Turn the returning cable adjuster ③ to obtain proper cable play.
- Loosen the locknut ④ of the throttle pulling cable ⑤.
- Turn the pulling cable adjuster ⑥ in or out until the throttle cable play ⑦ should be 2.0 – 4.0 mm (0.08 – 0.16 in) at the throttle grip.
- Tighten the locknut ④ securely while holding the adjuster ⑥.

DATA Throttle cable play ⑦: 2.0 – 4.0 mm (0.08 – 0.16 in)

- While holding the throttle grip at the fully closed position, slowly turn the returning cable adjuster ③ to obtain a slack ⑧ of 1.0 mm (0.04 in).
- Tighten the locknut ① securely.

⚠ WARNING

After the adjustment is completed, check that handlebar movement does not raise the engine idle speed and that the throttle grip returns smoothly and automatically.

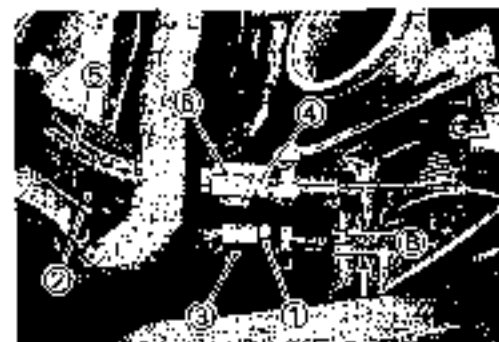
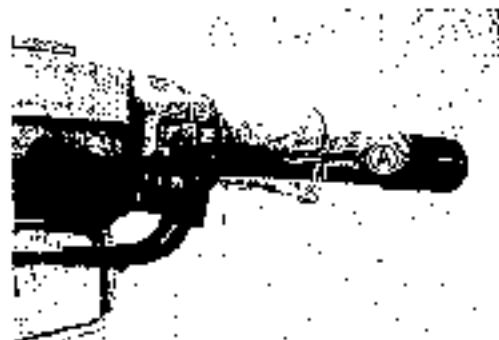
**THROTTLE VALVE SYNCHRONIZATION**

Inspect initially at 1 000 km (600 miles, 1 month) and every 12 000 km (7 500 miles, 12 months).

Inspect the throttle valve synchronization periodically. (C-7-24)

PAIR (AIR SUPPLY) SYSTEM

Inspect every 12 000 km (7 500 miles, 12 months).

Inspect the PAIR (air supply) system periodically. (C-12-6)

COOLING SYSTEM

Inspect every 6 000 km (4 000 miles, 6 months).
Replace engine coolant every 2 years.

ENGINE COOLANT LEVEL CHECK

- Keep the motorcycle upright with the center stand.
- Check the engine coolant level by observing the full and lower lines on the engine coolant reserve tank.
 - Ⓐ Full line Ⓑ Lower line
- If the level is below the lower line, add engine coolant to the full line from the engine coolant reserve tank filler. To remove the filler cap, remove the maintenance lid. (☞ 9-13)



ENGINE COOLANT CHANGE

- Remove the lower leg shield. (☞ 9-10)
- Remove the radiator cap Ⓐ.
- Drain engine coolant by removing the drain bolt Ⓐ.

⚠ WARNING

- Do not open the radiator cap when the engine is hot, as you may be injured by escaping hot liquid or vapor.
- Engine coolant may be harmful if swallowed or if it comes in contact with skin or eyes. If engine coolant gets into the eyes or in contact with the skin, flush thoroughly with plenty of water. If swallowed, induce vomiting and call physician immediately!



- Remove the front box. (☞ 9-18)
- Remove the foot board. (☞ 9-18)
- Drain engine coolant by disconnecting the radiator hose (2).
- Flush the radiator with fresh water if necessary.
- Tighten the water drain bolt (A) to the specified torque.

☞ Water drain bolt (A): 6 N·m (0.6 kgf-m, 4.3 lb-ft)

- Pour the specified engine coolant up to the radiator inlet.
- Bleed the air from the engine coolant circuit as following procedure.

NOTE:

For engine coolant information, refer to page 8-3.

AIR BLEEDING THE ENGINE COOLANT CIRCUIT

- Add engine coolant up to the radiator inlet.
- Support the motorcycle upright with the center stand.
- Slowly swing the motorcycle, right and left, to bleed the air trapped.
- Add engine coolant up to the radiator inlet.
- Start the engine and bleed air from the radiator inlet completely.
- Add engine coolant up to the radiator inlet.
- Repeat the above procedure until bleed no air from the radiator inlet.

- Close the radiator cap (1) securely.
- After warming up and cooling down the engine several times, add the engine coolant up to the full level of the reserve tank.

CAUTION

Repeat the above procedure several times and make sure that the radiator is filled with engine coolant up to the reserve tank full level.

LLC Engine coolant capacity

Reverse tank side: 250 ml (0.3/0.2 US/imp qt)
 Engine side: 1 050 ml (1.1/0.9 US/imp qt)

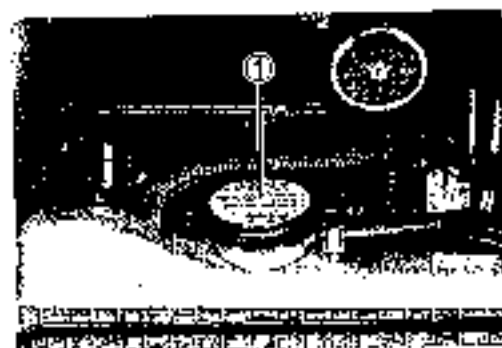

RADIATOR HOSES

Check to see the radiator hoses for crack, damage or engine coolant leakage.

If any defects are found, replace the radiator hoses with new ones.



BRAKE

(BRAKE)

Inspect initially at 1 000 km (600 miles, 1 month) and every 8 000 km (4 000 miles, 6 months) thereafter.

(BRAKE HOSE AND BRAKE FLUID)

Inspect every 6 000 km (4 000 miles, 6 months). Replace hoses every 4 years. Replace fluid every 2 years.

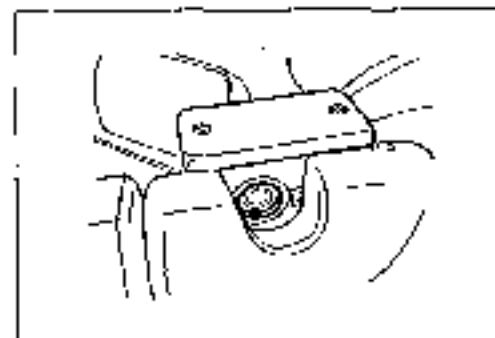
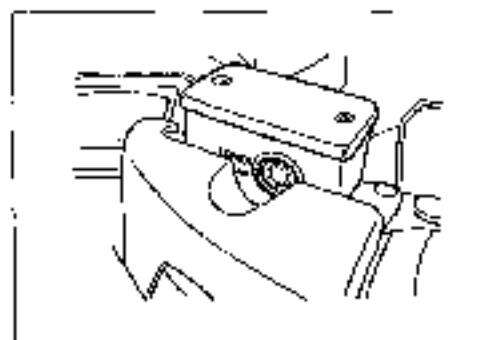

BRAKE FLUID LEVEL CHECK

- Keep the motorcycle upright and place the handlebars straight.
- Check the brake fluid level by observing the lower limit lines on the front and rear brake fluid reservoirs.
- When the level is below the lower limit line, replenish with brake fluid that meets the following specification.

 **Specification and Classification: DOT 4**

⚠ WARNING

The brake system of this motorcycle is filled with a glycol-based brake fluid. Do not use or mix different types of fluid such as silicone-based or petroleum-based. Do not use any brake fluid taken from old, used or unsealed containers. Never re-use brake fluid left over from the last servicing or stored for a long period.

⚠ WARNING

Brake fluid, if it leaks, will interfere with safe riding and immediately discolor painted surfaces. Check the brake hoses and hose joints for cracks and fluid leakage before riding.

BRAKE PADS

The extent of brake pad wear can be checked by observing the grooved limit **(A)** on the pad. When the wear exceeds the grooved limit, replace the pads with new ones. (I 9-64, 9-74)

CAUTION

Replace the brake pad as a set, otherwise braking performance will be adversely affected.

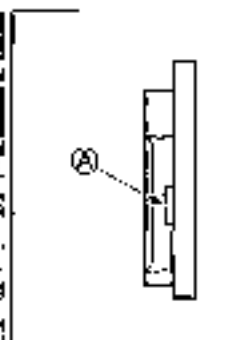
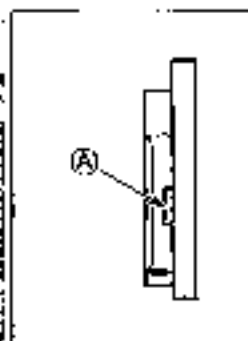

AIR BLEEDING THE BRAKE FLUID CIRCUIT

Air trapped in the fluid circuit acts like a cushion to absorb a large proportion of the pressure developed by the master cylinder and thus interferes with the full braking performance of the brake caliper. The presence of air is indicated by "sponginess" of the brake lever and also by lack of braking force. Considering the danger to which such trapped air exposes the machine and rider, it is essential that, after remounting the brake and restoring the brake system to the normal condition, the brake fluid circuit be purged of air in the following manner:

- Fill up the master cylinder reservoir to the "UPPER" line. Place the reservoir up to prevent entry of dirt.
- Attach a pipe to the air bleeder valve, and insert the free end of the pipe into a receptacle.

ⓘ Air bleeder valve: 7.5 N·m (0.75 kgf-m, 5.5 lb-ft)

- Front brake: Bleed the air from the air bleeder valve.
- Squeeze and release the brake lever several times in rapid succession and squeeze the lever fully without releasing it. Loosen the bleeder valve by turning it a quarter of a turn so that the brake fluid runs into the receptacle; this will remove the tension of the brake lever causing it to touch the handlebar grip. Then, close the valve, pump and squeeze the lever, and open the valve. Repeat this process until the fluid flowing into the receptacle no longer contains air bubbles.

NOTE:

Replenish the brake fluid in the reservoir as necessary while bleeding the brake system. Make sure that there is always some fluid visible in the reservoir.

- Close the bleeder valve, and disconnect the pipe. Fill the reservoir with brake fluid to the "UPPER" line.

CAUTION

Handle brake fluid with care: the fluid reacts chemically with paint, plastics, rubber materials and so on.



- The procedure to bleed the rear brake is identical to that of the front.



TIRE

Inspect every 8 000 km (4 000 miles, 6 months).

TIRE TREAD CONDITION

Operating the motorcycle with excessively worn tires will decrease riding stability and consequently invite a dangerous situation. It is highly recommended to replace a tire when the remaining depth of tire tread reaches the following specification:

 D0000-20805: Tire depth gauge

DATA Tire tread depth

Service Limit (FRONT): 1.5 mm (0.06 in)

(REAR): 2.0 mm (0.08 in)

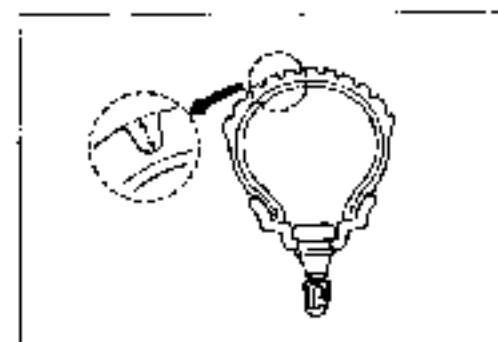

TIRE PRESSURE

If the tire pressure is too high or too low, steering will be adversely affected and tire wear increased. Therefore, maintain the correct tire pressure for good roadability or shorter tire life will result. Cold inflation tire pressure is as follows.

COLD INFLATION TIRE PRESSURE	SOLO RIDING			DUAL RIDING		
	kPa	kgf/cm ²	psi	kPa	kgf/cm ²	psi
FRONT	225	2.25	33	225	2.25	33
REAR	250	2.50	36	280	2.80	41

CAUTION

The standard tire fitted on this motorcycle is 120/70 R15M/C 56H for front and 160/60 R14M/C 65H for rear. The use of tires other than those specified may cause instability. It is highly recommended to use a SUZUKI Genuine Tire.

TIRE TYPE

BRIDGESTONE (Front: TH01F Rear: TH01R)

STEERING

Inspect initially at 1 000 km (600 miles, 1 month) and every 12 000 km (7 500 miles, 12 months) thereafter.

Steering should be adjusted properly for smooth turning of handlebars and safe running. Overtight steering prevents smooth turning of the handlebars and too loose steering will cause poor stability. Check that there is no play in the steering stem while grasping the lower fork tubes by supporting the machine so that the front wheel is off the ground, with the wheel straight ahead, and pull forward. If play is found, perform steering bearing adjustment as described in page 9-46 of this manual.

FRONT FORK

Inspect every 12 000 km (7 500 miles, 12 months).

Inspect the front forks for oil leakage, scoring or scratches on the outer surface of the inner tubes. Replace any defective parts, if necessary. (P9-32)

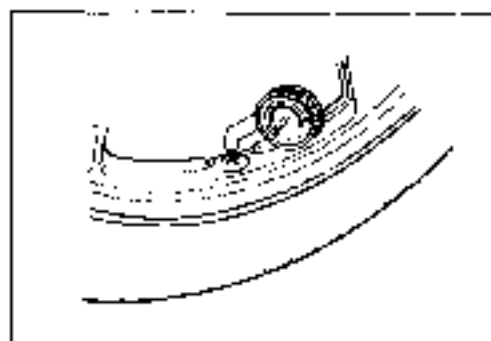

REAR SUSPENSION

Inspect every 12 000 km (7 500 miles, 12 months).

Inspect the rear shock absorbers for oil leakage and mounting rubbers for wear and damage. Replace any defective parts, if necessary. (☐ 9-57)



EXHAUST PIPE BOLT AND MUFFLER MOUNTING BOLT

Tighten initially at 1 000 km (600 miles, 1 month) and every 12 000 km (7 500 miles, 12 months) thereafter.

- Tighten the exhaust pipe bolts, muffler mounting bolts and nut to the specified torque.

- ☑ Muffler mounting bolt /nut (A): 23 N·m (2.3 kgf-m, 16.5 lb-ft)
Exhaust pipe bolt (B): 23 N·m (2.3 kgf-m, 16.5 lb-ft)



CHASSIS BOLT AND NUT

Tighten initially at 1 000 km (600 miles, 1 month) and every 6 000 km (4 000 miles, 6 months) thereafter.

Check that all chassis bolts and nuts are tightened to their specified torque. (Refer to page 2-28 for the locations of the following nuts and bolts on the motorcycle.)

ITEM		N·m	kgf·m	lb·ft
① Steering stem head nut		65	6.5	47.0
② Front fork upper clamp bolt		23	2.3	16.5
③ Front fork lower clamp bolt		23	2.3	16.5
④ Front axle		65	6.5	47.0
⑤ Front axle pinch bolt		23	2.3	16.5
⑥ Handlebar clamp bolt		23	2.3	16.5
⑦ Front brake master cylinder mounting bolt		10	1.0	7.0
⑧ Front brake caliper mounting bolt		26	2.6	19.0
⑨ Brake hose union bolt		23	2.3	16.5
⑩ Air bleeder valve		7.5	0.75	5.5
⑪ Brake disc bolt (Front & Rear)		23	2.3	16.5
⑫ Rear brake caliper mounting bolt		26	2.6	19.0
⑬ Rear brake master cylinder mounting bolt		10	1.0	7.0
⑭ Front footrest bracket mounting bolt	(M8)	26	2.6	19.0
	(M6)	11	1.1	8.0
⑮ Swingarm pivot nut		100	10.0	72.5
⑯ Rear shock absorber mounting nut (Upper & Lower)		29	2.9	21.0
⑰ Rear axle nut		100	10.0	72.5



COMPRESSION PRESSURE CHECK

The compression of a cylinder is a good indicator of its internal condition.

The decision to overhaul the cylinder is often based on the results of a compression test. Periodic maintenance records kept at your dealership should include compression readings for each maintenance service.

COMPRESSION PRESSURE SPECIFICATION

Standard	Limit	Difference
1 500 - 1 900 kPa (15 - 19 kgf/cm ²) (213 - 270 psi)	1 200 kPa (12 kgf/cm ²) (171 psi)	200 kPa (2 kgf/cm ²) (29 psi)

Low compression pressure can indicate any of the following conditions:

- * Excessively worn cylinder walls
- * Worn-down piston or piston rings
- * Piston rings stuck in grooves
- * Poor seating of valves
- * Ruptured or otherwise defective cylinder head gasket

Overhaul the engine in the following cases:

- * Compression pressure in one of the cylinders is less than 1 200 kPa (12 kgf/cm², 171 psi).
- * Difference in compression pressure between two cylinders is more than 200 kPa (2 kgf/cm², 29 psi).
- * All compression pressure are below 1 500 kPa (15 kgf/cm², 213 psi) even when they measure more than 1 200 kPa (12 kgf/cm², 171 psi).

COMPRESSION TEST PROCEDURE

NOTE:

- * Before testing the engine for compression pressure, make sure that the cylinder head bolts are tightened to the specified torque values and valves are properly adjusted.
- * Have the engine warmed up by idling before testing.
- * Be sure that the battery used is in fully-charged condition.

Remove the parts concerned and test the compression pressure in the following manner:

- * Support the motorcycle with the center stand.
- * Move the radiator. (REF-2-6)
- * Remove all the spark plugs. (REF-2-6)
- * Fill the compression gauge in one of the plug holes, while taking care of the tight connection.
- * Keep the throttle grip in full-open position.
- * While cranking the engine a few seconds with the starter, and record the maximum gauge reading as the compression of that cylinder.
- * Repeat this procedure with an other cylinder.

-  09915-64512: Compression gauge
- 09915-63311: Compression gauge attachment
- 09915-74521: Gauge hose



OIL PRESSURE CHECK

Check periodically the oil pressure in the engine to judge roughly the condition of the moving parts.

OIL PRESSURE SPECIFICATION

Above 350 kPa (3.5 kgf/cm ² , 50 psi)	at 3 000 r/min., Oil temp. at 80°C (140°F)
Below 550 kPa (5.5 kgf/cm ² , 78 psi)	

If the oil pressure is lower or higher than the specification, the following causes may be considered.

LOW OIL PRESSURE

- Clogged oil filter
- Oil leakage from the oil passage way
- Damaged O-ring
- Defective oil pump
- Combination of the above items

HIGH OIL PRESSURE

- Used of high viscosity engine oil
- Clogged oil passage way
- Combination of the above items

OIL PRESSURE TEST PROCEDURE

Start the engine and check if the oil pressure indicator light is turned on. If it keeps on lighting, check the oil pressure indicator light circuit. If it is in good condition, check the oil pressure in the following manner.

- Remove the main oil gallery plug (1).
- Install the oil pressure gauge with attachment in the position shown in the figure.
- Warm up the engine as follows:
 - Summer 10 min. at 2 000 r/min.
 - Winter 20 min. at 2 000 r/min.
- After warming up, increase the engine speed to 3 000 r/min (with the engine tachometer), and read the oil pressure gauge.

- 09915-74521: Gauge hose
 - 09915-74532: Oil pressure gauge attachment
 - 09915-74511: Oil pressure gauge

- Oil gallery plug [M8]: 10 N·m (1.0 kgf·m, 7.3 lb-ft)

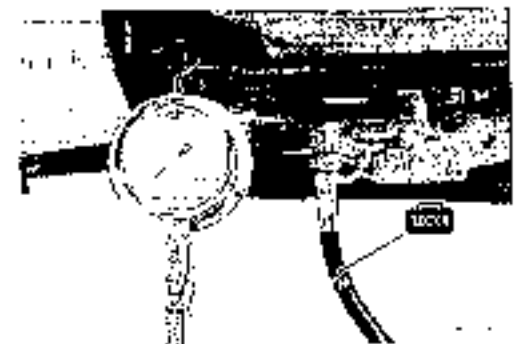

AUTOMATIC CLUTCH INSPECTION

This motorcycle is equipped with an automatic clutch and variable ratio belt drive transmission. The engagement of the clutch is governed by engine RPMs and centrifugal mechanism located in the clutch.

To insure proper performance and longer lifetime of the clutch assembly it is essential that the clutch engages smoothly and gradually. The following inspections must be performed:

1. INITIAL ENGAGEMENT INSPECTION

- Warm up the engine to normal operating temperature.
- Start the engine.
- Seated on the motorcycle with the motorcycle on level ground, increase the engine RPMs slowly and note the RPM at which the motorcycle begins to move forward.

 09900-26006: Tachometer

 Engagement r/min: 1 500 – 2 100 r/min

2. CLUTCH "LOCK-UP" INSPECTION

Perform this inspection to determine if the clutch is engaging fully and not slipping.

- Start the engine.
- Apply the front and rear brakes as firm as possible.
- Briefly open the throttle fully and note the maximum engine RPMs sustained during the test cycle.

CAUTION:

Do not apply full power for more than 3 seconds or damage to the clutch or engine may occur.

 Lock-up r/min: 3 200 – 3 600 r/min

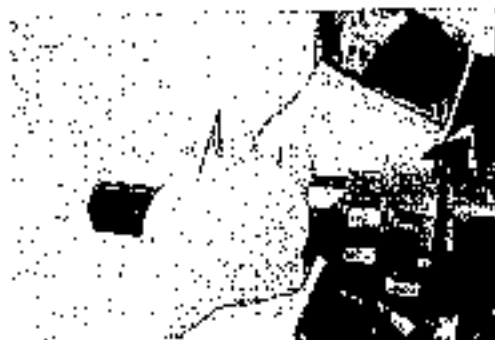
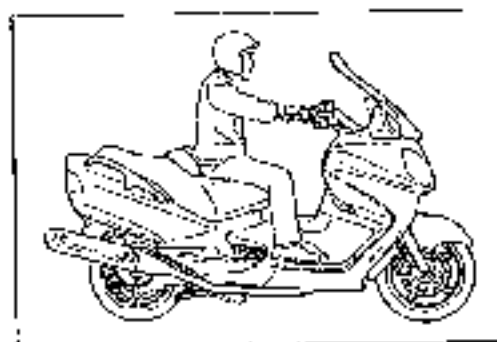

BRAKE-LOCK INSPECTION

Inspect that the rear wheel is locked up when pulling the brake-lock lever 4 to 6 notches and moving the motorcycle forward to make sure that the brake-lock acts enough.

Adjust the brake-lock, if necessary. (☐ 9-85)

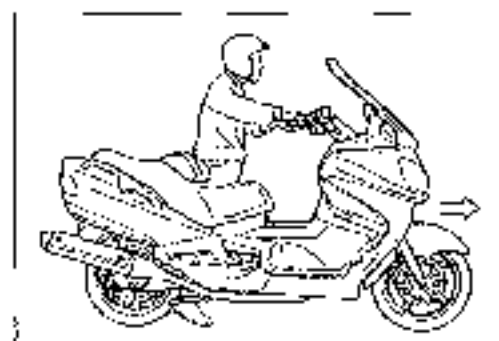

ENGINE**CONTENTS**

ENGINE COMPONENTS REMOVABLE WITH THE ENGINE	
IN PLACE	3- 2
ENGINE REMOVAL AND REMOUNTING	3- 3
ENGINE REMOVAL	3- 3
ENGINE REMOUNTING	3-10
ENGINE DISASSEMBLY	3-12
ENGINE COMPONENT INSPECTION AND SERVICE	
CYLINDER HEAD COVER	3-22
CAMSHAFT	3-23
CAM CHAIN TENSION ADJUSTER	3-25
CAM CHAIN TENSIONER	3-25
CAM CHAIN GUIDE	3-25
CYLINDER HEAD	3-26
CYLINDER	3-34
PISTON AND PISTON RING	3-36
CLUTCH	3-38
STARTER CLUTCH	3-43
STARTER TORQUE LIMITER	3-44
OIL PUMP	3-44
OIL PRESSURE REGULATOR/OIL SUMP FILTER	3-44
CRANK BALANCER	3-45
DRIVE SHAFT	3-45
CONROD/CRANKSHAFT	3-47
OIL JET	3-55
CRANKCASE	3-56
ENGINE REASSEMBLY	3-59

ENGINE COMPONENTS REMOVABLE WITH THE ENGINE IN PLACE

Engine components which can be removed while the engine is installed on the chassis are listed below. For the installing and removing procedures, refer to respective paragraphs describing each component.

ITEM	REMOVAL	INSPECTION	INSTALLATION
CENTER OF ENGINE			
Muffler	☞ 3-7	—	☞ 3-11
Cylinder head cover	☞ 3-12	☞ 3-22	☞ 3-74
Camshaft	☞ 3-12	☞ 3-23	☞ 3-72
Starter motor	☞ 3-12	☞ 10-13	☞ 3-75
Cam chain tensioner adjuster	☞ 3-13	☞ 3-25	☞ 3-71
Cylinder head	☞ 3-13	☞ 3-26	☞ 3-71
Cylinder	☞ 3-13	☞ 3-34	☞ 3-70
Oil level switch	☞ 3-12	☞ 10-29	☞ 3-75
Piston	☞ 3-14	☞ 3-36	☞ 3-70
Oil filter/Oil cooler	☞ 3-17	—	☞ 3-63
Cam position sensor	☞ 3-22	☞ 6-27	☞ 3-23
Engine coolant temperature switch	☞ 8-12	☞ 8-13	☞ 8-13
RIGHT OF ENGINE			
Starter clutch	☞ 3-16	☞ 3-43	☞ 3-64
Starter torque limiter	☞ 3-16	☞ 3-44	☞ 3-64
Thermostat	☞ 3-34	☞ 8-14	☞ 3-35
LEFT SIDE OF ENGINE			
Oil sump filler	☞ 3-15	☞ 3-44	☞ 3-67
Generator	☞ 3-15	☞ 10-9	☞ 3-67
CKP sensor	☞ 3-15	☞ 6-28	—
Clutch	☞ 3-16	☞ 3-40	☞ 3-66
Oil pressure switch	☞ 3-56	☞ 10-36	☞ 3-56

ENGINE REMOVAL AND REMOUNTING

ENGINE REMOVAL

- Drain the engine oil transmission oil. (☞ 2-10, 2-13)
- Drain the engine coolant. (☞ 2-20)

NOTE:

If the engine is stained, clean with steam cleaner before removal.

- Cover the part (A) and (B) to prevent water from entering the CVT unit.



EXTERNAL PARTS

- Remove the following parts: (☞ 9-6)
- Lower leg shield. Front leg shield cover. Leg shield. Front box. Maintenance lid. Lower frame cover. Center frame cover. Pillion rider handle. Trunk box cover. Frame cover. Foot board. Trunk box. Rear fender. Leg side cover.
- Remove the final gear case cover. (☞ 10-48)
- Disconnect the battery terminals. (☞ 10-3)

CAUTION

Remove the battery terminals from the (←) side first.

- Disconnect the joint hose (1), and breather hose (2)



- Remove the air cleaner box (3).



- Remove the IAP sensor load wire coupler (1), IAT sensor (2), and PAIR solenoid valve load wire coupler (3).
- Disconnect the vacuum hose (4).



- Remove the PAIR solenoid valve (5).
- Remove the air chamber (6).



- Disconnect the throttle cables (7).
- Disconnect the injector couplers (8).
- Disconnect the TP sensor coupler (9) and IAC valve coupler (10).
- Remove the throttle body assembly.



- Disconnect the secondary air hose (1) and breather hose (2).

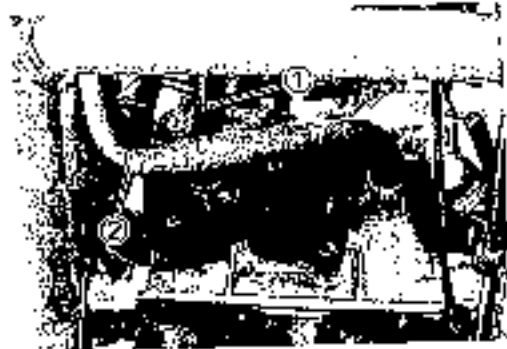

- Disconnect the air vent hose (3) and radiator nose (4).
- Disconnect the radiator outlet hose.



- Disconnect the cooling fan switch coupler (5).



- Remove the radiator.

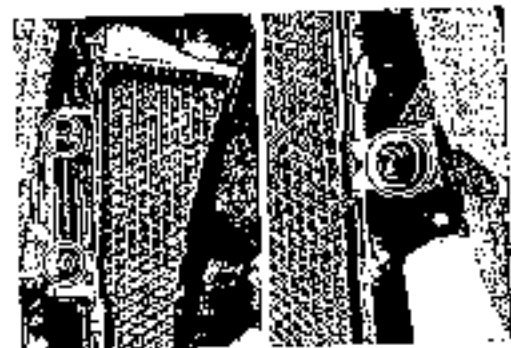

- Disconnect the engine ground lead wire earth.



- Disconnect the center stand switch lead wire coupler (1), CVT pulley position sensor lead wire coupler (2), CVT motor lead wire coupler (3), CVT secondary pulley revolution sensor lead wire coupler (4), and HO2 sensor lead wire coupler (5).



- Disconnect the starter motor lead wire.
- Disconnect the ECT sensor coupler (6).



- Disconnect the side stand switch lead wire coupler (7), oil pressure switch lead wire coupler (8), oil level switch lead wire (9), CKP sensor coupler (10), and trunk light seat switch lead coupler (11).



- Disconnect the cam position sensor coupler (12).
- Remove the ignition coil/plug cap.



- Disconnect the generator coupler (1).
- Disconnect the HO2 sensor coupler (2).



- Remove the muffler.

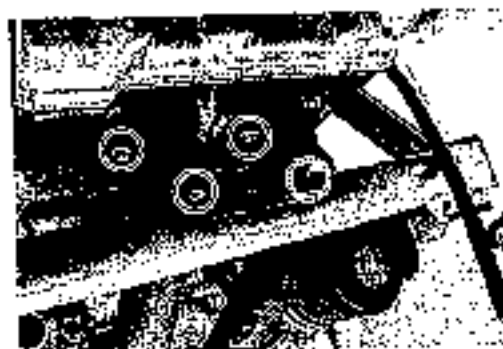

- Remove the brake lock cable clamp.
- Remove the rear brake hose clamp.
- Remove the rear brake calliper bolt and remove the rear brake calliper (3).
- Remove the both rear shock absorber lower bolts (4).



3-8 ENGINE

- Remove the clamp.
- Move the fuel hose not to interfere with the work.



- Support the engine using an engine jack.
- Remove the engine mounting bolt and nut.



- Remove the foot board bracket.

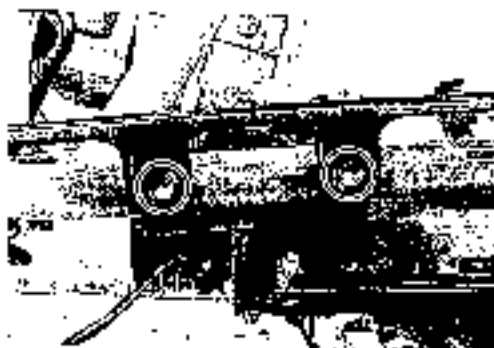

- Remove the engine from the frame.

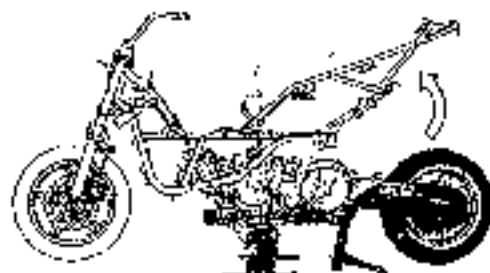

- Remove the CVT assembly. (C-75-2)

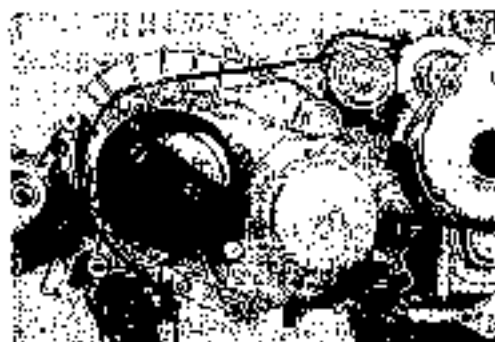

- Remove the swingarm. (C-78-59)



- Remove the final gear case. (C-74-31)

CAUTION:

Be careful not to allow the engine main body to fall down.

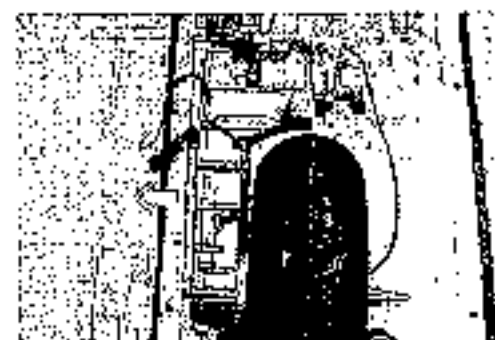

- Remove the center stand.

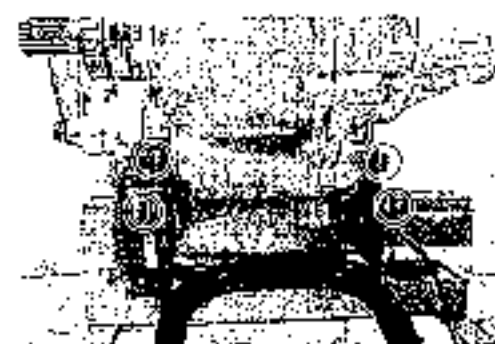

ENGINE REMOUNTING

- Reinstall the engine assembly following the procedure below:
 - Assembling of center stand (C/F 11-26)
 - Installation of final gear case (C/F 4-7)
 - Installation of rear wheel (C/F 9-56)
 - Installation of CVT unit (C/F 5-4)
 - Installation of rear brake caliper (C/F 9-87)
- Pass through the engine mounting bolt from the right side of the chassis.
- Tighten the engine mounting nut with the specified torque

CAUTION

The engine mounting nut is the self-lock type and cannot be used repeatedly. If the self-lock effect is lost, replace it with new one.

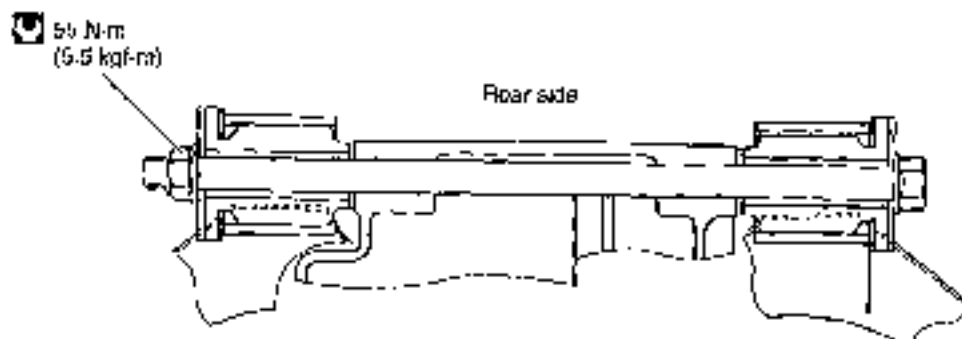
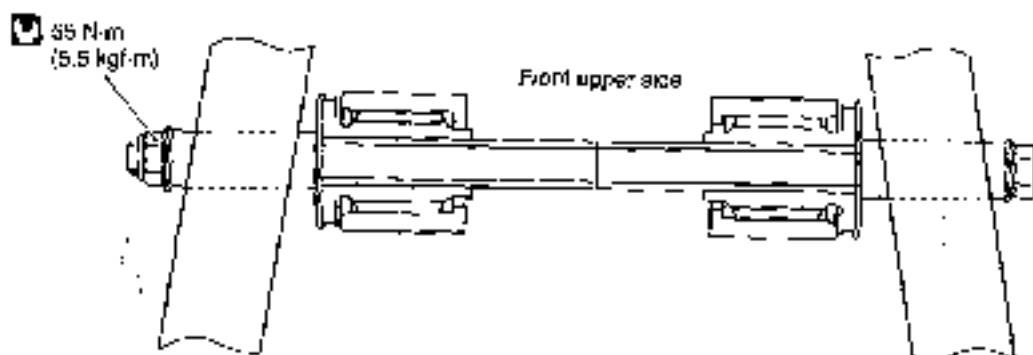
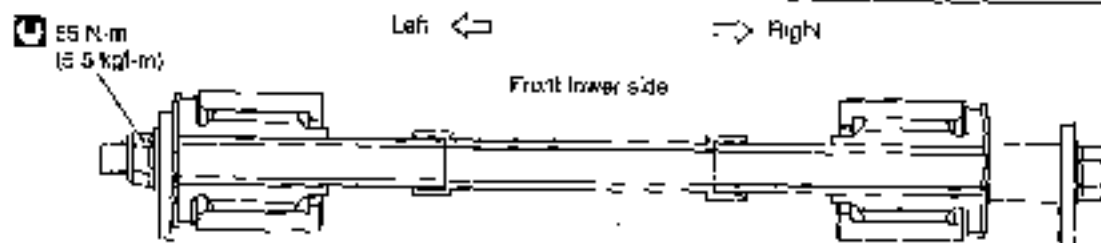

MUFFLER

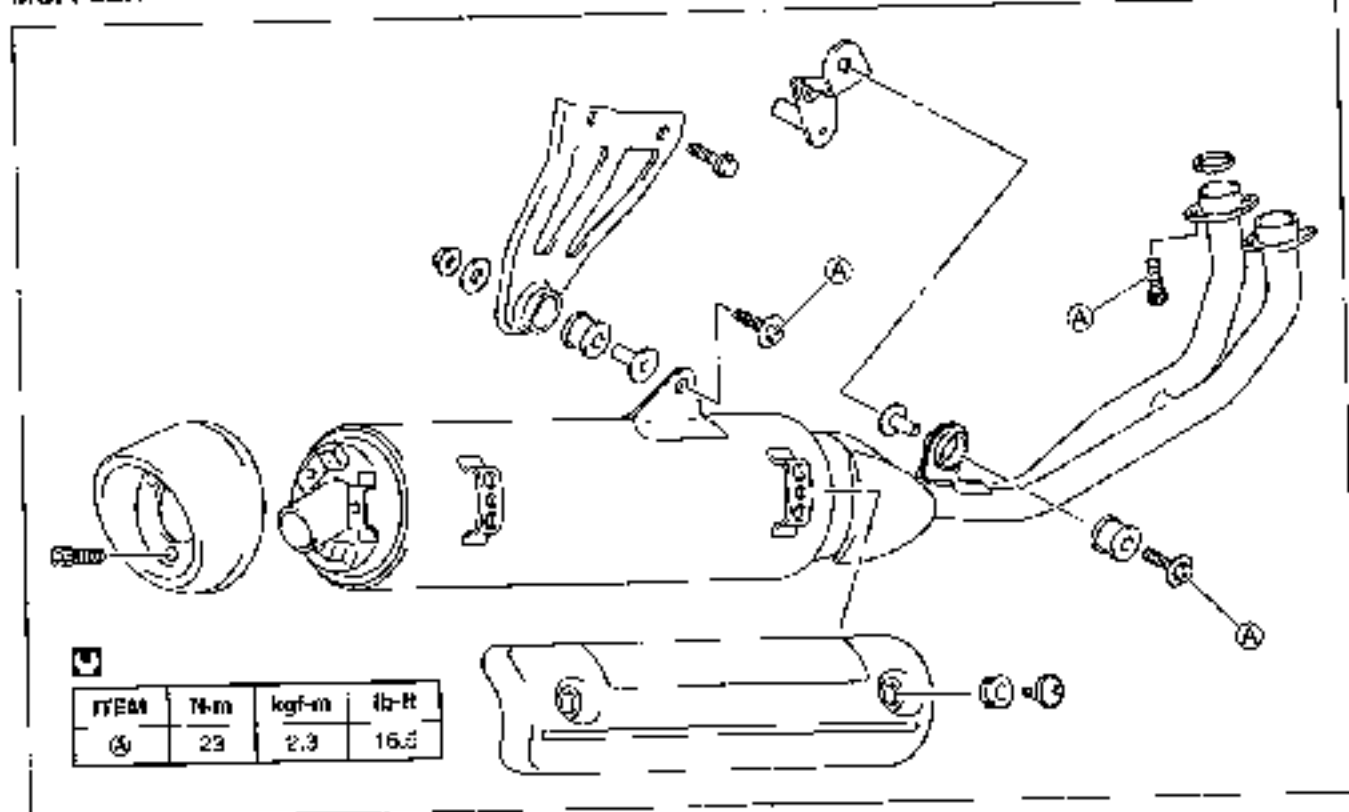

After mounting the engine, connect the wiring, cables and hoses securely. (☞ 11-14, 11-18)

- Supply a specified amount of engine oil and transmission oil. (☞ 2-13)
- Supply a specified amount of cooling water (☞ 2-29)

Adjust the following items:

- Play of throttle cable (☞ 2-18, 2-19)
- Idling rpm (☞ 2-18)
- Check the leak of oil, cooling water, etc.

ENGINE DISASSEMBLY

STARTER MOTOR

- Remove the starter motor (1).
- Disconnect the water bypass hose (2).



OIL PRESSURE SWITCH

- Remove the oil pressure switch.

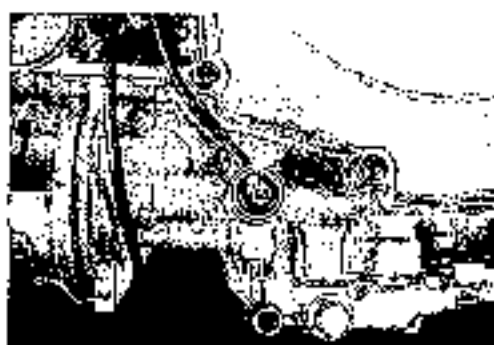

OIL LEVEL SWITCH

- Remove the oil level switch (1).



CYLINDER HEAD COVER

- Remove the cylinder head cover (1).

NOTE:

Do not remove the dowel pin at the back of the cylinder head since it is embedded.

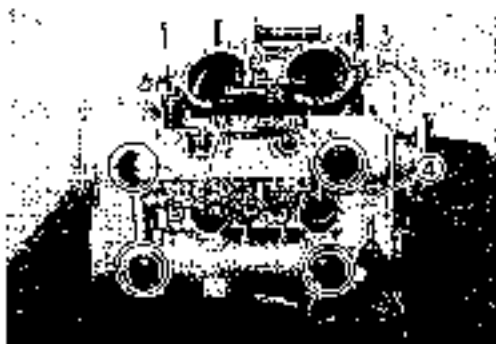

CAM SHAFT

- Remove the starter clutch cover plug and bring the piston to the top dead center point turning the crankshaft. (C/F 2-8)

NOTE:

Take note of the tappet clearance. (C/F 2-8)



- Push the cam chain tension adjuster rod and insert the special tool

 09918-53B10: Chain tensioner lock tool

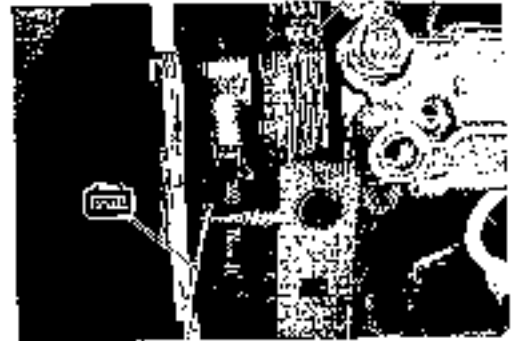

- Remove the two camshaft journal holders (1) by removing the bolts.

CAUTION

Be sure to loosen the camshaft journal holder bolts evenly by shifting the wrench diagonally.

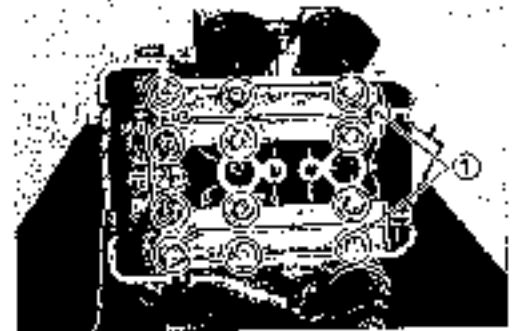

- Remove the camshaft.

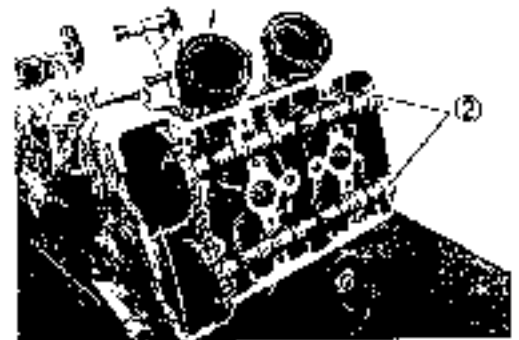

CYLINDER HEAD, AND CYLINDER

- Remove the cylinder head side bolt.
- Remove the cam chain tensioner adjuster.



- Loosen the cylinder head bolt (3).
- Remove the cylinder head bolt.
- Remove the cylinder head assembly.

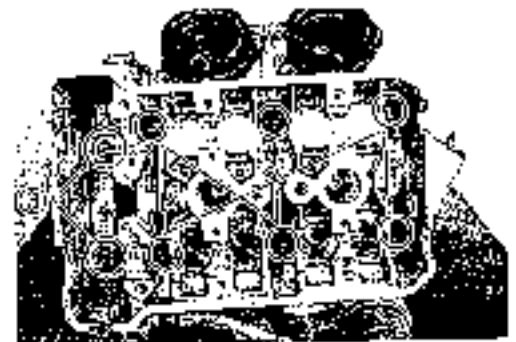

- Remove the cylinder head gasket (1), dowel pins (2), and cam chain guide (3).
- Remove the cylinder (4).

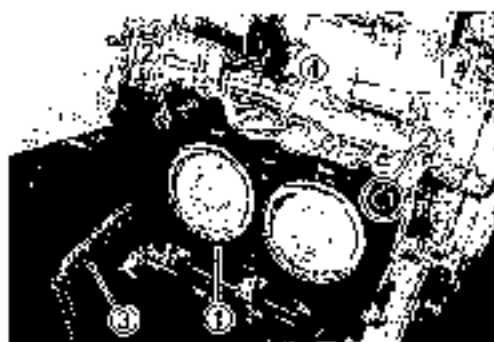

- Remove the cylinder base gasket (5), and dowel pins (6).

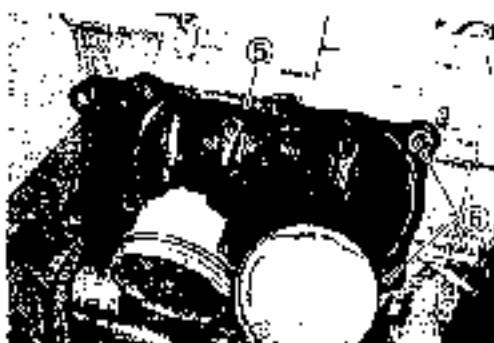

PISTON

- Place a clean rag over the cylinder base so as not to drop the piston pin circlip into the crankcase.
- Remove the piston pin circlip.
- Remove the piston by driving out the piston pin.

NOTE:

- *Scribe the piston number on the head of the piston.*



OIL HOSE

- Remove the oil hose (7) and oil return hose (8).

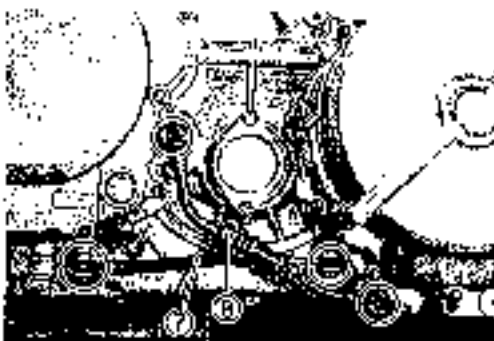

GENERATOR COVER

- Remove the generator cover.

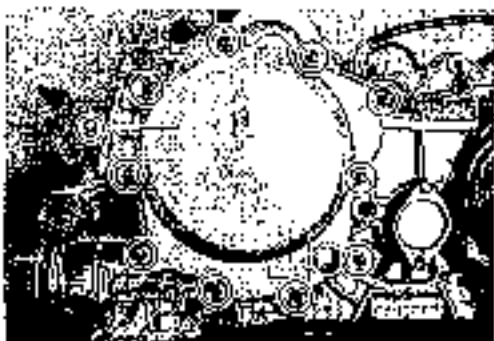

- Remove the oil sump filter ①.



GENERATOR

- Remove the generator rotor nut with the special tool.

 09930-40113: Rotor holder

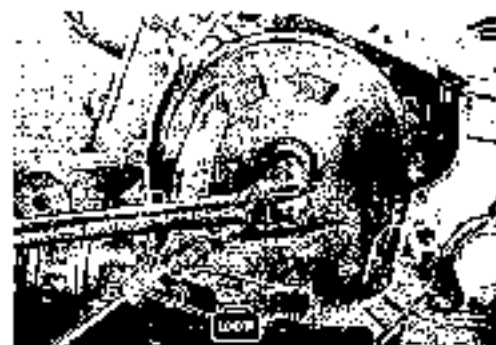

- Remove the generator rotor ② with the special tools.

 09930-40113: Rotor holder
09930-30450: Rotor remover



- Remove the generator stator ③, CKP sensor ④ and lead wire guide ⑤.
- Remove the key.



CLUTCH

- Remove the clutch cover (1).

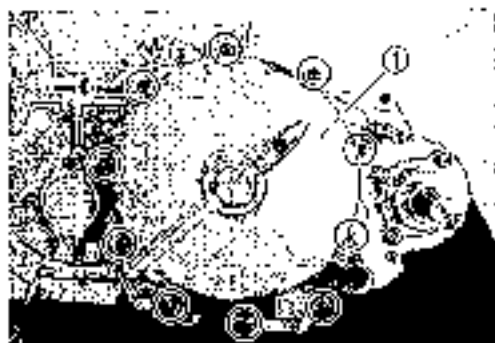

- Remove the clutch housing nut and washer.
- Remove the clutch assembly.

 05930-40113: Rotor holder

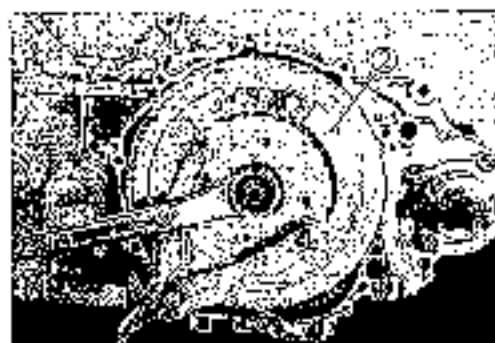

- Remove the clutch shaft (3).
- Remove the drive shaft oil seal retainer (4).

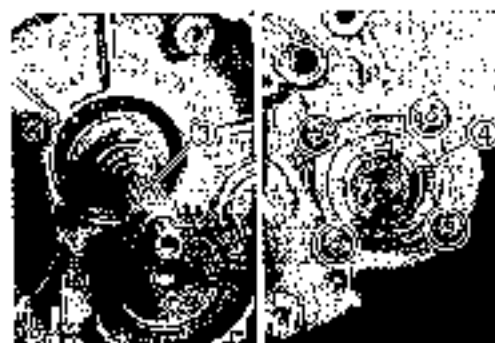

STARTER CLUTCH

- Remove the starter clutch cover (5).

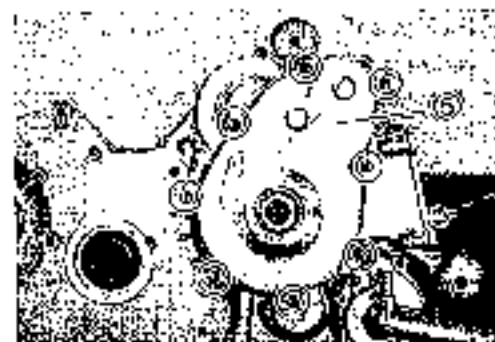

- Remove the starter torque limiter shaft (6), starter torque limiter (7), and washer.
- Remove the starter idle gear shaft (8), and starter gear (9).



- Remove the starter clutch bolt and washer with the special tool.

 09920-34830: Starter clutch rotor holder

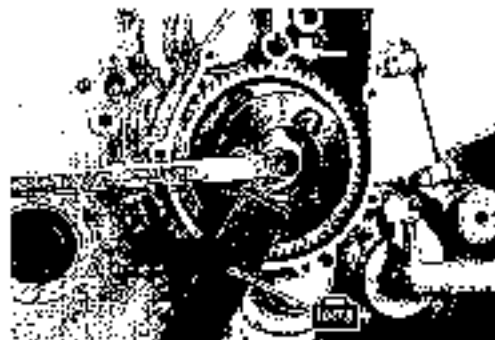

CAM CHAIN

- Remove the cam chain tensioner ① and cam chain ②.



- Remove the cam chain sprocket ③.



WATER PUMP

- Remove the water pump assembly

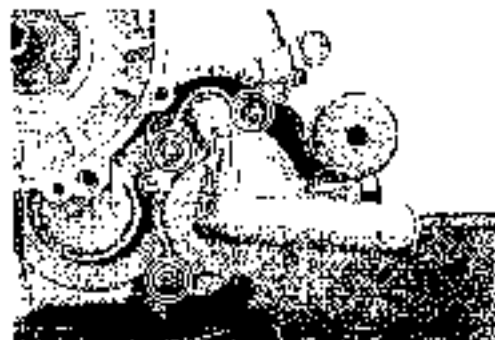

OIL FILTER

- Remove the oil filter (3) with the special tool.

 09915-40610: Oil filter wrench



OIL COOLER

- Untighten the union bolt and remove the oil cooler.

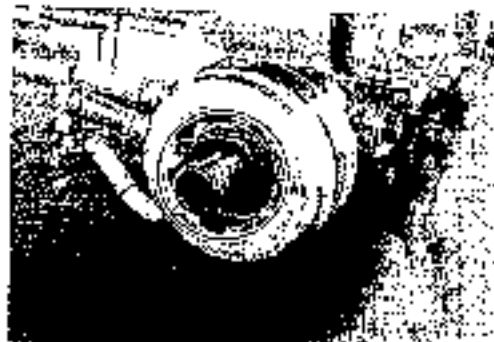

SEPARATION OF CRANKCASE

- Untighten the crankcase tightening bolt.

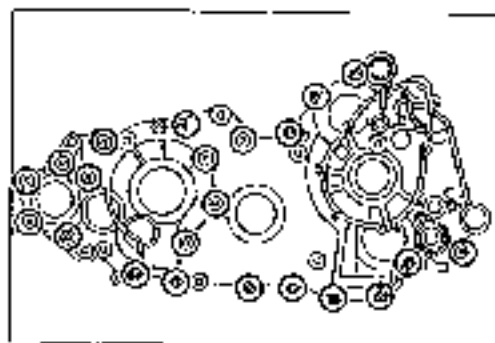
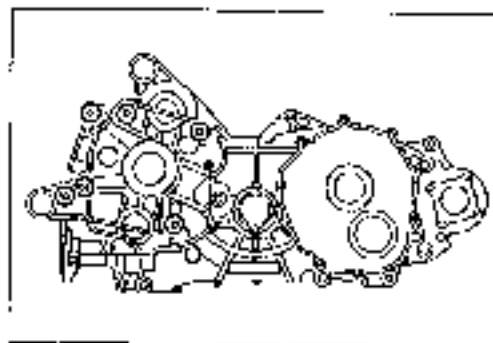

- Separate the crankcase into 2 parts right and left with the crankcase separating tool.

 09920-13120: Crankcase/crankshaft separator

NOTE:

- Pay attention when separating the crankcase so that it is kept horizontal with the mating surface.
- Fit the crankcase separating tool, so that the tool arms are in parallel with the side of crankcase.

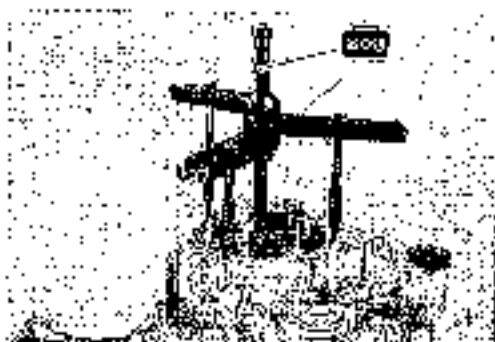

DRIVE SHAFT

- Remove the drive shaft assembly ①, idle shaft ②.

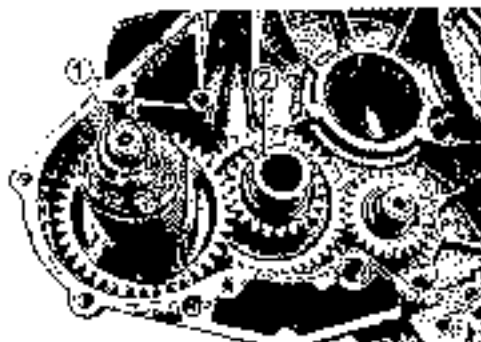

- Remove the id/a gear ③.
- Remove the circlip ④, and counter drive gear ⑤.



- Remove the counter drive gear shaft ⑥.

**BALANCER SHAFT**

- Remove the upper balancer shaft ⑦.



- Remove the circlip ⑧, lower balancer shaft ⑨, oil pump gear ⑩, and oil pump drive chain.

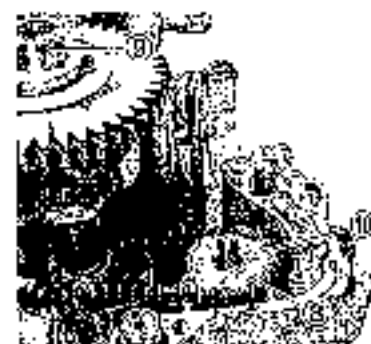

OIL PUMP

- Remove the pin ①, washer ②, oil pump assembly ③.



- Remove the oil sump filter ④.



OIL PRESSURE REGULATOR

- Remove the oil pressure regulator ⑤.



PISTON COOLING NOZZLE

- Remove the piston cooling nozzle.



- Remove the O-ring



- Remove the oil separator.



CRANKSHAFT

- Remove the crankshaft assembly (1).

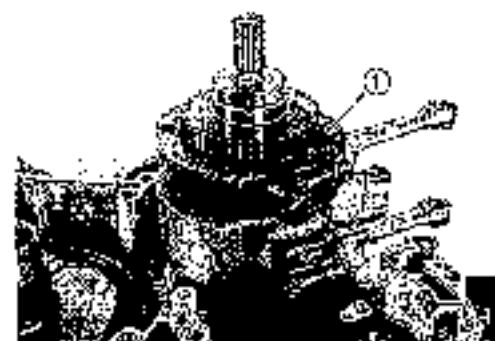

PRIMARY DRIVEN GEAR

- Remove the primary drive gear (2).



RETURN OIL PUMP

- Remove the circlip (3), and return oil pump gear (4).

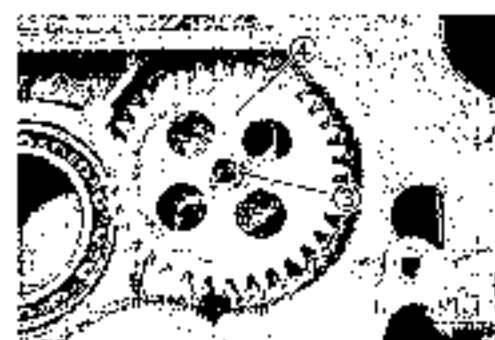

- Remove the pin (5), return oil pump assembly (6).



ENGINE COMPONENT INSPECTION AND SERVICE

CAUTION

Identify the position of each removed part. Organize the parts in their respective groups (i.e., intake, exhaust, No.1 or No.2) so that they can be installed in their original locations.

CYLINDER HEAD COVER

- Remove the PAIR read valve cover (1), cam position sensor (2), and breather cover (3).

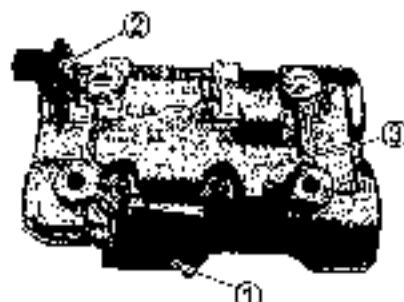

INSPECTION

- Inspect the reed valve for the carbon deposit.
- If the carbon deposit is found in the reed valve, replace the PAIR control valve with a new one.



REASSEMBLY

- Apply THREAD LOCK "1342" to the thread and install the PAIR reed valve cover.

 99000-32050: THREAD LOCK "1342"



- Check for stain and clogging in the breather and clean as required.
- Assemble a new gasket and breather cover and tighten the part (3) together with the clamp.

 Tightening torque: 10 N·m (1.0 kgf-m, 7.0 lb-ft)



CAM POSITION SENSOR

- Apply SUZUKI SUPER GREASE "A" to the O-ring and install it.

 Cam position sensor bolt: 10 N·m (1.0 kgf·m, 7.0 lb-ft)

 99000-25030: SUZUKI SUPER GREASE "A" (USA)

99000-25010: SUZUKI SUPER GREASE "A" (Others)

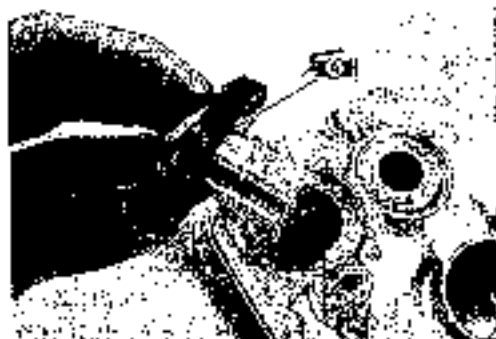
**CAMSHAFT**

- Exhaust camshaft and intake camshaft are distinguished by the marking.

Mark on the exhaust camshaft: B

Mark on the intake camshaft: A

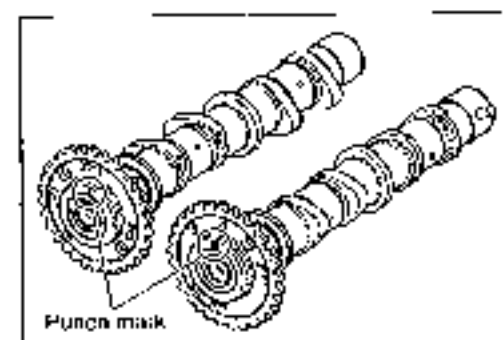
**CAM FACE**

- Check the sliding surface for extraordinary scratches or wear.
- Measure the cam height (A) with a micrometer.
- If the service limit has been exceeded, replace the camshaft.

DATA Cam height (A):

Service Limit (IN.): 35.1 mm (1.378 in)

(EX.): 33.7 mm (1.339 in)

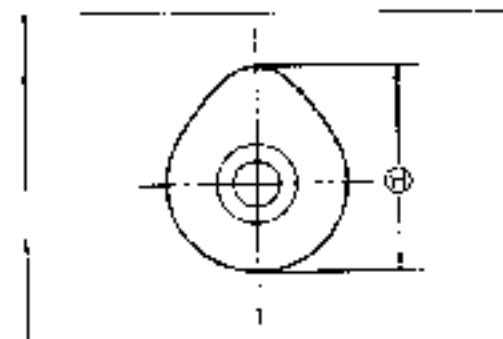
**CAMSHAFT RUNOUT**

- Measure the runout using the dial gauge.
- Replace the camshaft if the runout exceeds the limit.

 09900-20606: Dial gauge (1/100 mm)

09900-20701: Magnetic stand

09900-21304: V-block set (100 mm)

DATA Camshaft runout:

Service Limit (IN & EX): 0.10 mm (0.004 in)

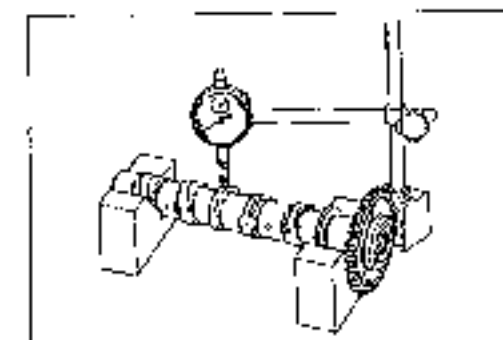

CAMSHAFT JOURNAL WEAR

- Determine whether or not each journal is worn down to the limit by measuring the oil clearance with the camshaft installed in place.
- Use the plastigauge to read the clearance at the widest portion, which is specified as follows:

DATA Camshaft journal oil clearance:

Standard: (IN & EX): 0.032 – 0.056 mm
(0.0013 – 0.0026 in)

Service Limit: (IN & EX): 0.150 mm (0.0059 in)

TOOL 09900-22301: Plastigauge
09900-22302: Plastigauge

- Tighten the camshaft journal holder to its evenly and diagonally to the specified torque.

⚙️ Camshaft journal holder bolt: 10 N.m (1.0 kgf.m, 7.4 lb-ft)

NOTE:

Do not rotate the camshaft with the plastigauge in place

- Remove the camshaft holders, and read the width of the compressed plastigauge with envelope scale.
- This measurement should be taken at the widest part.

- If the camshaft journal oil clearance measured exceeds the limit, measure the inside diameter of the camshaft journal holder and outside diameter of the camshaft journal.
- Replace the camshaft or the cylinder head depending upon which one exceeds the specification.

DATA Journal holder I.D.:

Standard: (IN & EX): 24.012 – 24.025 mm
(0.9454 – 0.9458 in)

TOOL 09900-20602: Dial gauge (1/1000, 1 mm)
09900-22403: Small bore gauge (18 – 35 mm)

DATA Camshaft journal O.D.:

Standard (IN & EX): 23.959 – 23.980 mm
(0.9433 – 0.9441 in)

TOOL 09900-20205: Micrometer (0 – 25 mm)

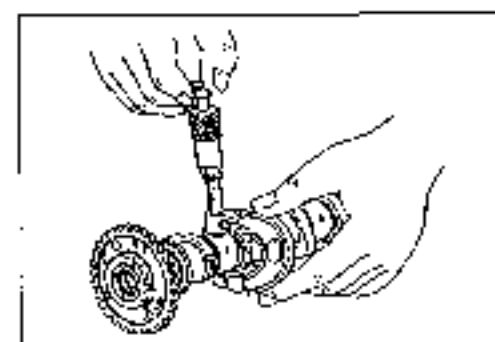
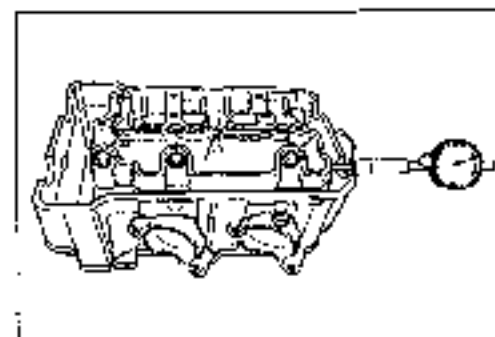
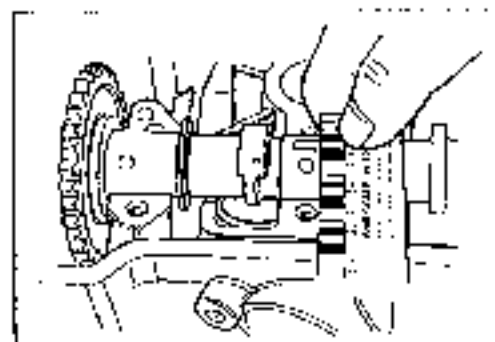

CAM CHAIN TENSION ADJUSTER

INSPECTION

- Remove the cam chain tension adjuster cap bolt.
- Check that the push rod slides smoothly when releasing stopper.
- If it does not slide smoothly, replace the cam chain tension adjuster with a new one.



CAM CHAIN TENSIONER

INSPECTION

- Check the contacting surface of the cam chain tensioner.
- If it is worn or damaged, replace it with a new one.



CAM CHAIN GUIDE

INSPECTION

- Check the contacting surfaces of the cam chain guides.
- If they are worn or damaged, replace them with the new ones.

CYLINDER HEAD**VALVE AND VALVE SPRING DIASSEMBLY**

- Remove the tappets and shims by fingers or magnetic hand.

CAUTION

Identify the position of each removed part.

- Remove the tappet and shim.
- Using special tools, compress the valve springs and remove the two cotter halves (1) from valve stem.

TOOL 09916-14510: Valve lifter

09916-14521: Valve lifter attachment (24 mm)

09916-84511: Tweezers

CAUTION

Be careful not to damage the tappet sliding surface with the special tool.

- Remove the valve spring retainer (2) and valve springs (3).
- Pull out the valve (4) from the other side.

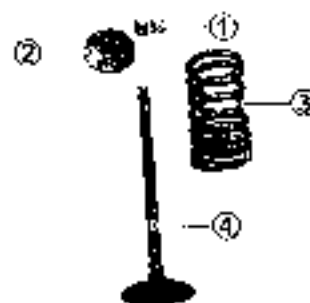
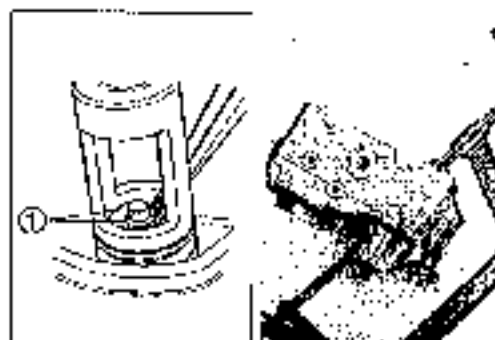

- Remove the oil seal (5).

CAUTION

Do not reuse the removed oil seal.

- Remove the spring seal (6).

**CYLINDER HEAD DISTORTION**

- Decarbonize the combustion chambers.
- Check the gasket surface of the cylinder head for distortion with a straightedge and thickness gauge, taking a clearance reading at several places indicated.
- If the largest reading at any position of the straightedge exceeds the limit, replace the cylinder head.

DATA Cylinder head distortion:

Service Limit: 0.10 mm (0.004 in)

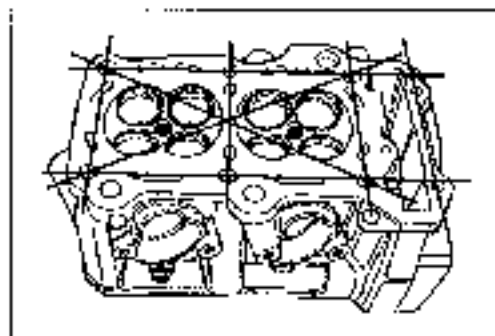

VALVE STEM DEFLECTION

- Lift the valve about 10 mm (0.39 in) from the valve seat.
- Measure the valve stem deflection in two directions, perpendicular to each other, by positioning the dial gauge as shown.
- If the deflection measured exceeds the limit, then determine whether the valve or the guide should be replaced with a new one.

TOOL 09900-20606: Dial gauge (1/100 mm)
09900-20701: Magnetic stand

DATA Valve stem deflection (IN & EX):
Service Limit: 0.35 mm (0.014 in)

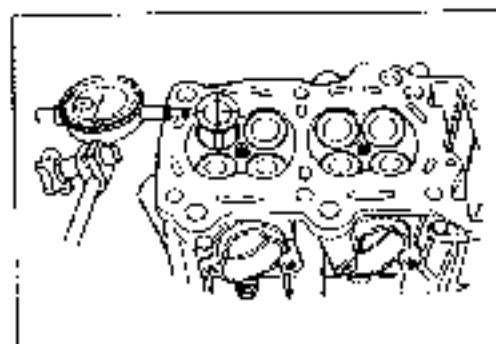
**VALVE STEM WEAR**

- If the valve stem is worn down to the limit, as measured with a micrometer, replace the valve.
- If the stem is within the limit, then replace the guide.
- After replacing valve or guide, be sure to recheck the deflection.

TOOL 09900-20205: Micrometer (0 - 25 mm)

DATA Valve stem O.D.:
Standard (IN): 4.475 - 4.490 mm (0.1762 - 0.1768 in)
(EX): 4.455 - 4.470 mm (0.1754 - 0.1760 in)

NOTE:

If valve guides have to be removed for replacement after inspecting related parts, carry out the steps shown in valve guide servicing. (3-9)

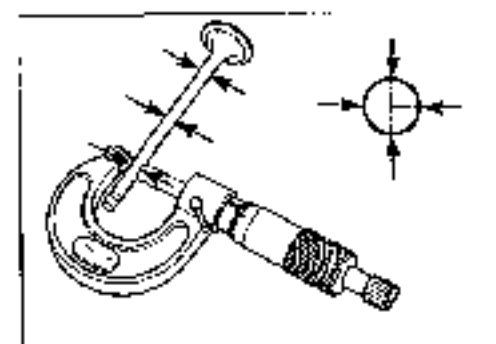
**VALVE STEM RUNOUT**

- Support the valve using V-blocks and check its runout using the dial gauge as shown.
- If the runout exceeds the service limit, replace the valve.

TOOL 09900-20606: Dial gauge (1/100 mm)
09900-20701: Magnetic stand
09900-21304: V-block set (100 mm)

DATA Valve stem runout: Service Limit: 0.05 mm (0.002 in)

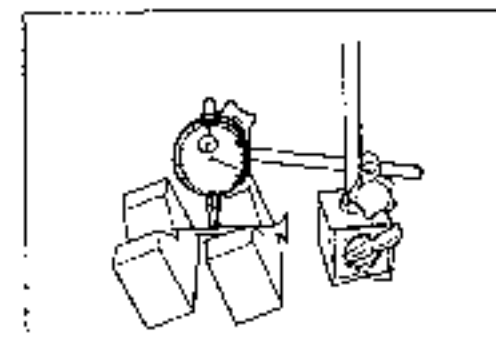
**VALVE HEAD RADIAL RUNOUT**

- Place the dial gauge at a right angle to the valve head face and measure the valve head radial runout.
- If it measures more than the service limit, replace the valve.

DATA Valve head radial runout:
Service Limit: 0.03 mm (0.001 in)

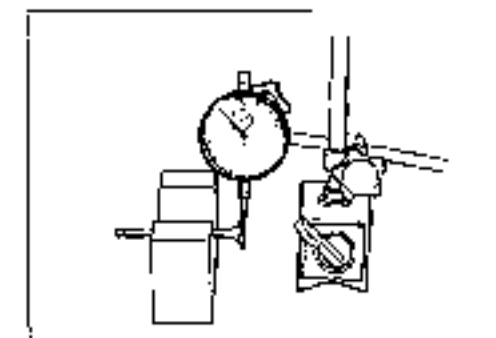

VALVE FACE WEAR

- Visually inspect each valve face for wear. Replace any valve with an abnormally worn face. The thickness of the valve face decreases as the face wears. Measure the valve face (①). If it is out of specification, replace the valve with a new one.②

DATA Valve head thickness (①):

Service Limit: 0.5 mm (0.02 in)

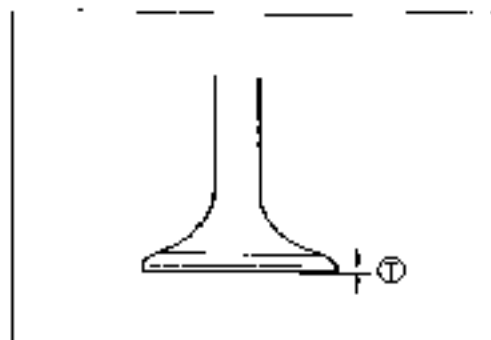
**VALVE SPRING**

The force of the coil springs keeps the valve seat tight. Weakened springs result in reduced engine power output, and often account for the chattering noise coming from the valve mechanism.

- Check the valve springs for proper strength by measuring their free length and also by the force required to compress them.
- If the spring length is less than the service limit, or if the force required to compress the spring does not fall within the range specified, replace both the inner and outer springs as a set.

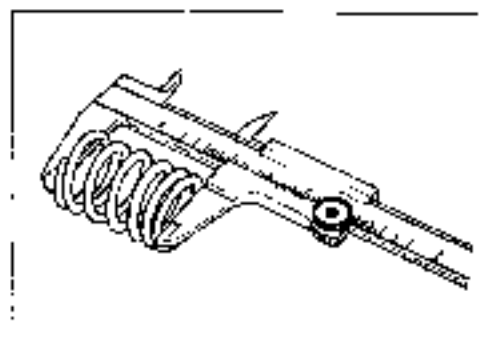

DATA 09900-20102: Vernier calipers

DATA Valve spring free length (IN & EX): Service limit:
40.6 mm (1.60 in)

DATA Valve spring tension (IN & EX): Standard:
136 - 156 N, 13.8 - 15.6 kgf/33.4 mm
(30.0 - 35.4 lbs/1.31 in)

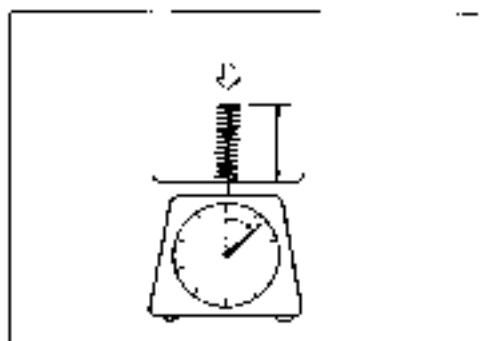

VALVE GUIDE SERVICING

- Using the valve guide remover, drive the valve guide nut toward the intake or exhaust camshaft side.

MOX 09916-53310: Valve guide remover/installer

NOTE:

- * Discard the removed valve guide subassemblies.
- * Only oversized valve guides are available as replacement parts. (Part No. 11115-33071)

- Refinish the valve guide holes in cylinder head with the reamer and handle.

MOX 09916-34561: Valve guide reamer
09916-34542: Reamer handle

CAUTION

When refinishing or removing the reamer from the valve guide hole, always turn it clockwise.

- Apply engine oil to the valve guide hole
- Drive the valve guide into the hole using the special tool

MOX 09916-43210: Valve guide installer/remover

NOTE:

Install the valve guide until the attachment contacts with the cylinder head.

MOX 09916-43210: Valve guide remover/installer
09916-44930: Valve guide installer attachment

CAUTION

Failure to oil the valve guide hole before driving the new guide into place may result in a damaged guide or head.

- After installing the valve guides, refinish their guiding bores using the reamer.
- Clean and oil the guides after reaming.

MOX 09916-33310: Valve guide reamer
09916-34542: Valve guide reamer handle

NOTE:

Insert the reamer from the combustion chamber and always turn the reamer handle clockwise.

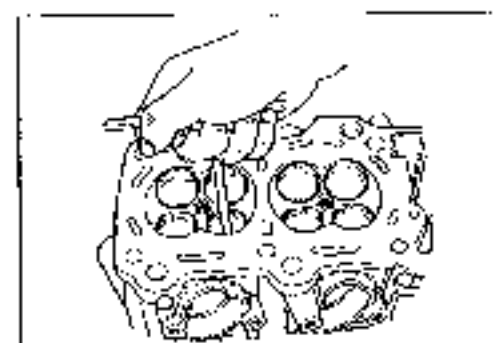
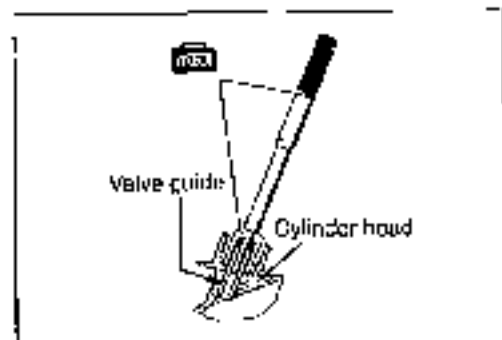
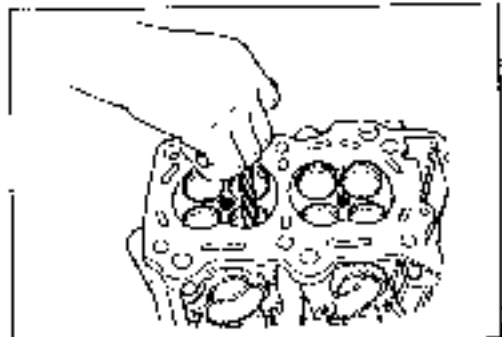
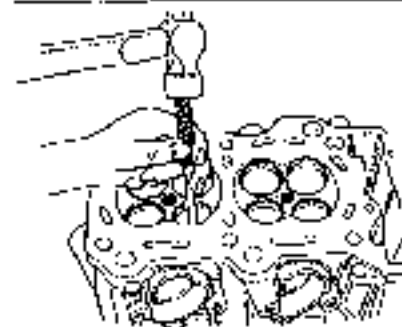

VALVE SEAT WIDTH INSPECTION

- Visually check for valve seat width on each valve face.
- If the valve face has worn abnormally, replace the valve.
- Coat the valve seat with Prussian Blue and set the valve in place. Rotate the valve with light pressure.
- Check that the transferred blue on the valve face is uniform all around and in center of the valve face.

 09916-10911: Valve rapper set

- If the seat width W measured exceeds the standard value, or seat width is not uniform retace the seat using the seat cutter.

DATA Valve seat width (g):

Standard: 0.9 – 1.1 mm (0.035 – 0.043 in)

If the valve seat is out of specification, recut the seat.

VALVE SEAT SERVICING

- The valve seats for both the intake and exhaust valves are machined to four different angles. The seat contact surface is cut at 45°.

	INTAKE	EXHAUST
15°		N-121
30°	N-126	
45°	N-122	N-122
60°	N-111	N-111

 09916-21111: Valve seat cutter set

09916-20630: Valve seat cutter (N-126)

09916-20640: Solid pilot (N-100-4.5)

NOTE:

The valve seat cutters (N-121), (N-122) and (N-111) are included in the valve seat cutter set (09916-21111).

CAUTION

The valve seat contact area must be inspected after each cut.

- When installing the solid pilot (1), rotate it slightly.

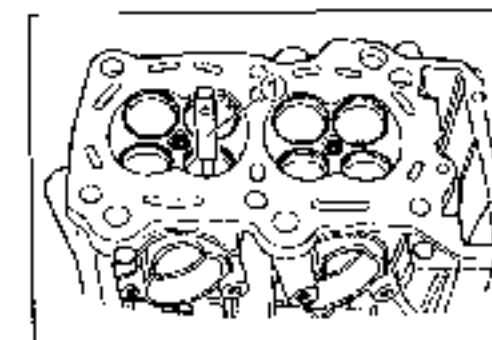
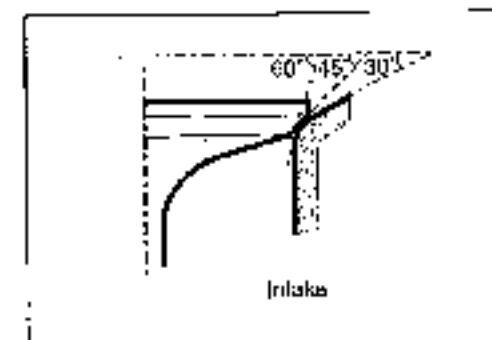
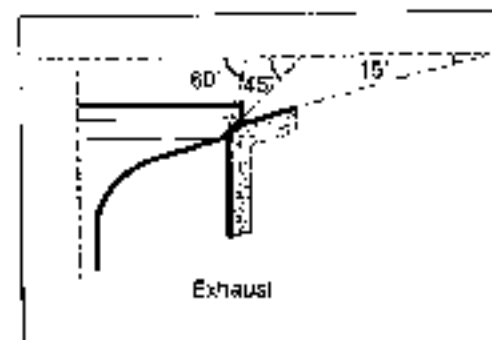
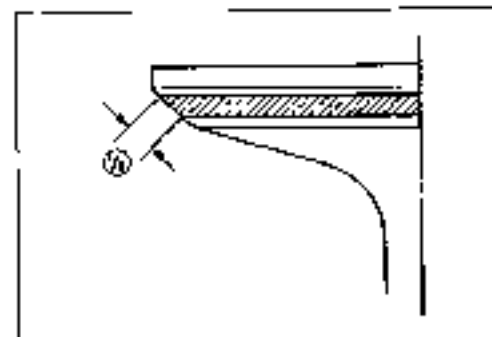
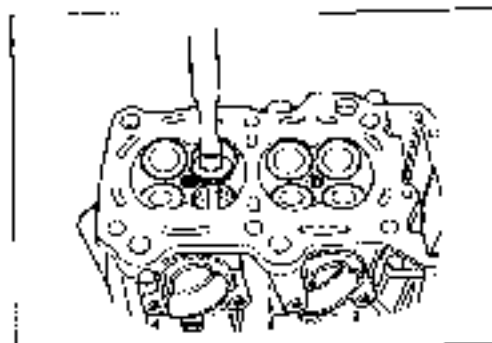

INITIAL SEAT CUT

- Install the 45° cutter (1), attachment (2) and T-handle (3).

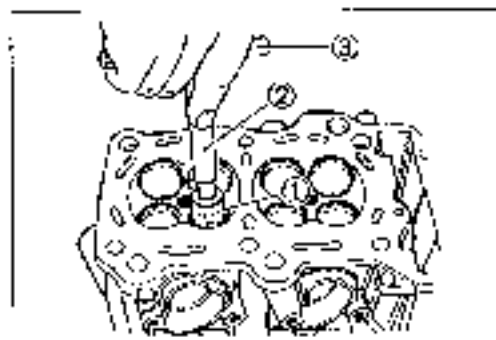

- Using the 45° cutter, descale and clean up the seat. Rotate the cutter one or two turns.
- Measure the valve seat width W after every cut.

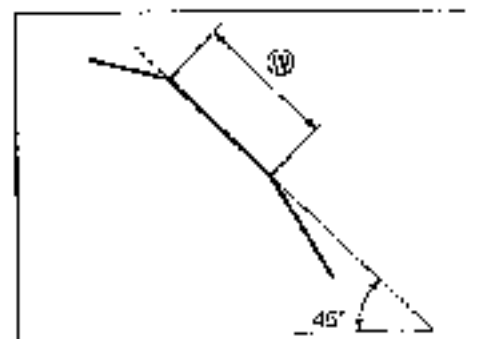

- If the valve seat is pitted or burned, use the 45° cutter to condition the seat some more.

NOTE:

Cut only the minimum amount necessary from the seat to prevent the possibility of the valve stem becoming too close to the camshaft.

**TOP NARROWING CUT**

- If the contact area (4) is too high on the valve, or if it is too wide, use the 15° (for the exhaust side) and the 30° (for the intake side) to lower and narrow the contact area.

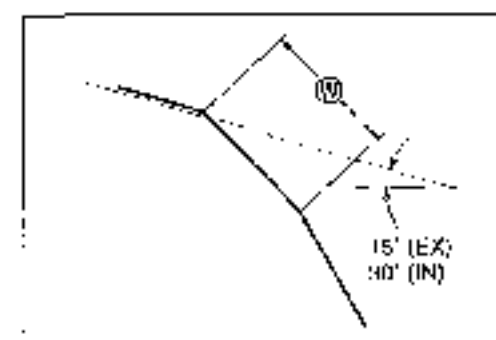
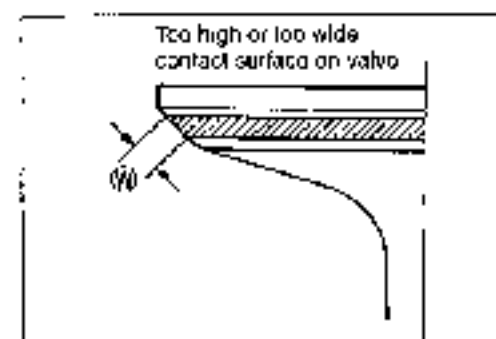

BOTTOM NARROWING CUT

- If the contact area \textcircled{A} is too wide or too low, use the 60° cutter to narrow and raise the contact area.

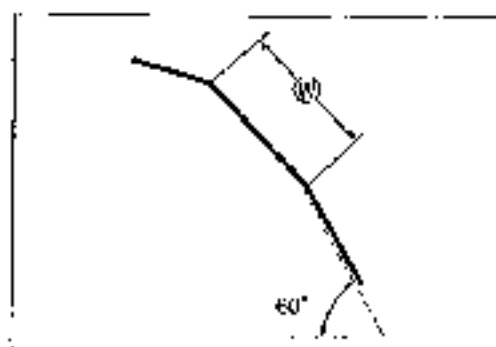
**FINAL SEAT CUT**

- If the contact area \textcircled{A} is too low or too narrow, use the 45° cutter to raise and widen the contact area.

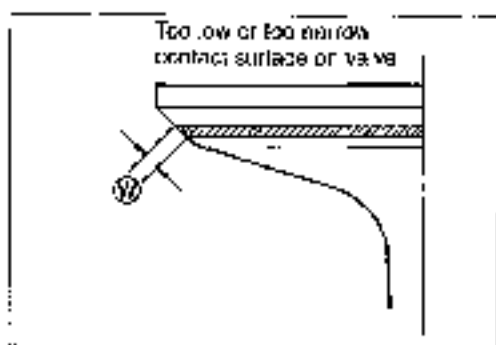
**NOTE:**

After cutting the 15°, 30° and 60° angles, it is possible that the valve seat (45°) is too narrow. If so, recut the valve seat to the correct width.

- After the desired seat position and width is achieved, use the 45° cutter very lightly to clean up any burrs caused by the previous cutting operations.

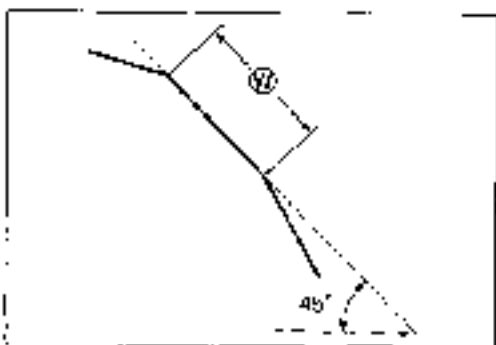
**CAUTION**

Do not use lapping compound after the final cut is made. The finished valve seat should have a velvety smooth finish but not a highly polished or shiny finish. This will provide a soft surface for the final seating of the valve which will occur during the first few seconds of engine operation.

NOTE:

After servicing the valve seats, be sure to check the tappet clearance after the cylinder head has been reinstalled. (F 2-9)

- Clean and assemble the head and valve components. Fill the intake and exhaust ports with gasoline to check for leaks.
- If any leaks occur, inspect the valve seat and face for burrs or other things that could prevent the valve from sealing.

WARNING

Always use extreme caution when handling gasoline.

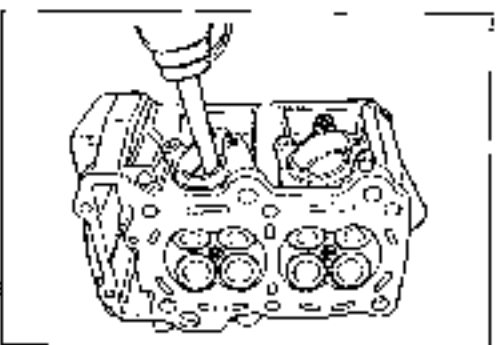

VALVE AND VALVE SPRING REASSEMBLY

- Apply molybdenum oil solution to each oil seal, and press-fit them into position with the valve guide installer.

 09916-43210: Valve guide remover/installer

 MOLYBDENUM OIL SOLUTION

CAUTION

Do not reuse the removed oil seals.

- Insert the valves, with their stems coated with molybdenum oil solution all around and along the full stem length without any break.

CAUTION

When inserting each valve, take care not to damage the lip of the oil seal.

 MOLYBDENUM OIL SOLUTION

- Install the valve springs with the small-pitch portion facing cylinder head.

 Small-pitch portion

 Large-pitch portion

- Put on the valve spring retainer, and using the valve lifter, press down the springs, fit the cotter halves to the stem end, and release the lifter to allow the cotter (1) to wedge in between retainer and stem. Be sure that the rounded lip (2) of the cotter fits snugly into the groove (3) in the stem end.

 09916-14510: Valve lifter

09916-14521: Valve lifter attachment

09916-84511: Tweezers

CAUTION

Be sure to restore each spring and valve to their original positions.

- Install the tappet shims and the tappets to their original position.

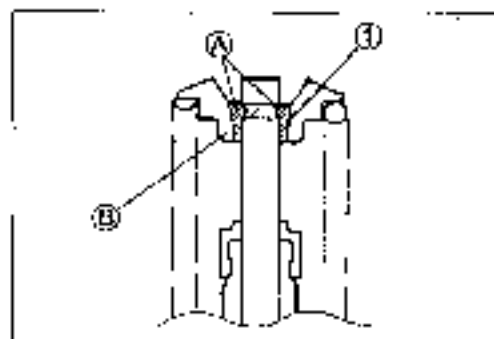
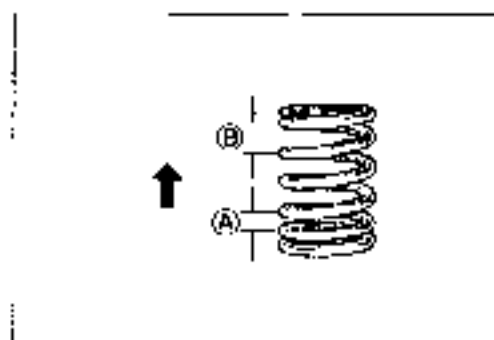
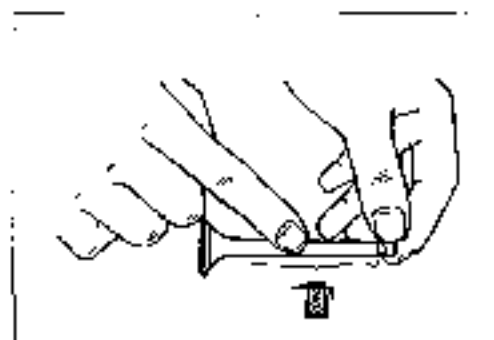
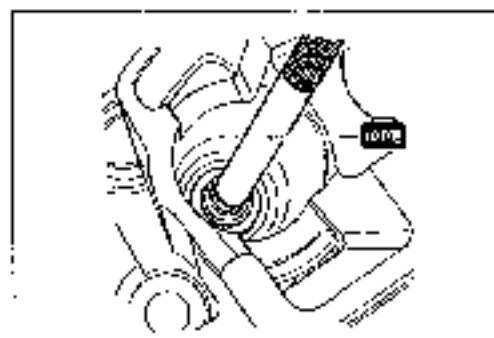

NOTE:

- Apply engine oil to the shim and tappet before fitting them.
- When seating the tappet shim, be sure the figure printed surface faces the tappet. (Fig. 2-9)

**INTAKE PIPE**

- Coat the O-ring with grease and install the intake pipe together with the O-ring.

TOOL 99000-25030: SUZUKI SUPER GREASE "A" (USA)
99000-25010: SUZUKI SUPER GREASE "A" (Others)

**CYLINDER**

- Disconnect the water pipe (1) and remove the O-ring.

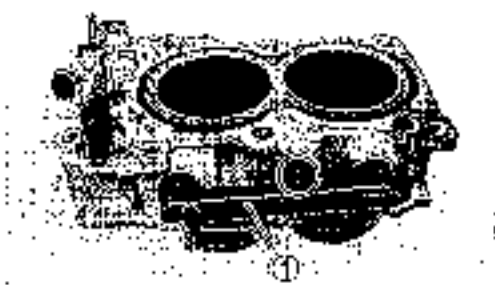

- Unsighten the thermostat case bolt.
- Remove the thermostat (2).

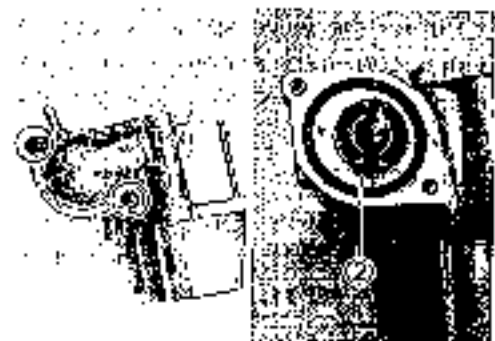
**CYLINDER DISTORTION**

- Check the gasket surface of the cylinder for distortion with a straightedge and thickness gauge, taking a clearance reading at several places as indicated.
- IF the largest reading at any position of the straightedge exceeds the limit, replace the cylinder.

TOOL 09900-20803: Thickness gauge

DATA Cylinder distortion:

Service Limit: 0.10 mm (0.004 in)

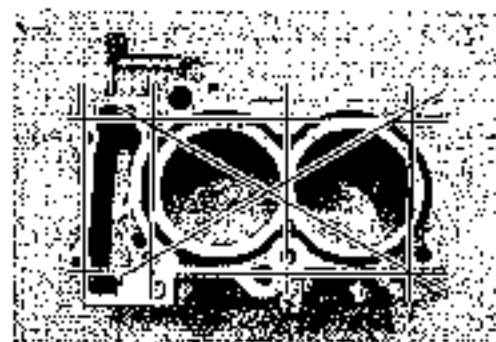

CYLINDER BORE

- Check the cylinder bore for stepped wear or scars.
- Measure the 6 positions as shown in the right figure with a cylinder gauge.

09900-20508: Cylinder gauge set

DATA Cylinder bore:

Standard: 75.500 – 75.515 mm (2.9724 – 2.9730 in)

Service Limit: 75.585 mm (2.9758 in)

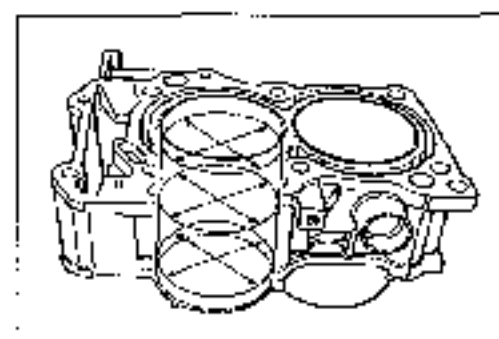
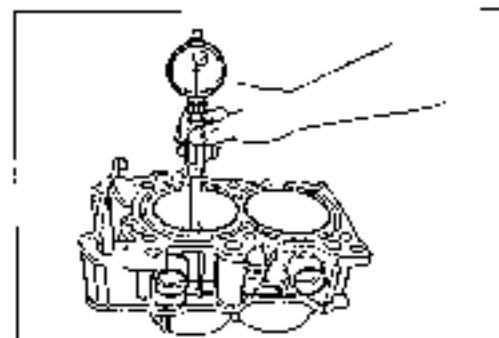

- Fit the O-ring (1) to the water pipe and install the water pipe to the cylinder.
- Coat the water pipe bolt with screw lock agent and tighten the water pipe with the bolt.

09900-32050: THREAD LOCK "1342"

CAUTION

Use new O-rings.

- Install the thermostat to the cylinder.
- Tighten the thermostat case bolt.

NOTE:

Position the thermostat jiggle valve as shown in the photo.

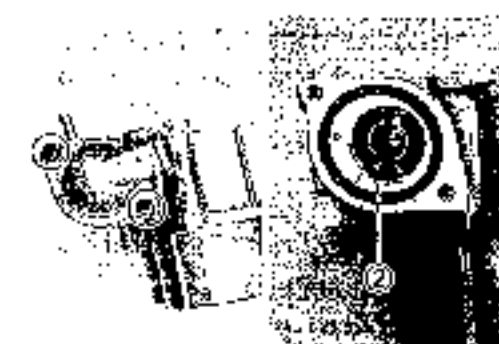
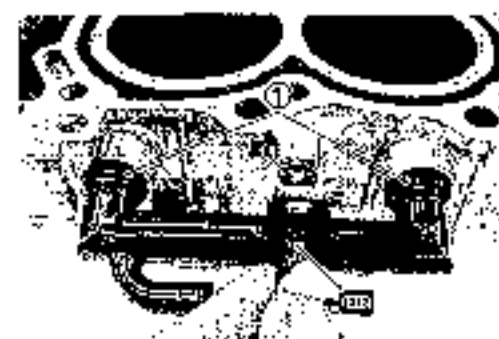

PISTON AND PISTON RING

PISTON DIAMETER

- Using a micrometer, measure the piston outside diameter at 15 mm (0.6 in) from the piston skirt end.
- If the measurement is less than the limit, replace the piston.

DATA Piston diameter:

Standard: 75.450 – 75.465 mm (2.9704 – 2.9710 in)

Service Limit: 75.380 mm (2.9677 in)

at 15 mm (0.6 in) from the skirt end

 09900-20204: Micrometer (75 – 100 mm)

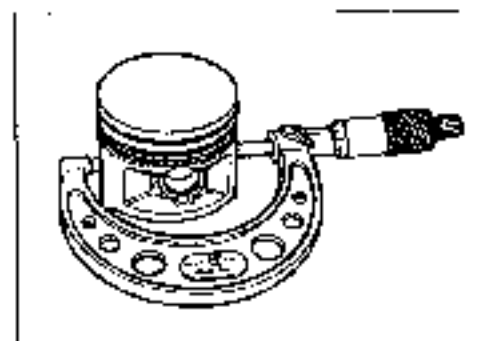
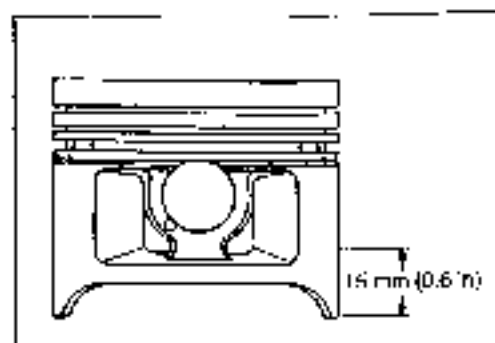

PISTON TO CYLINDER CLEARANCE

- Subtract the piston diameter from the cylinder bore diameter.
- If the piston to cylinder clearance exceeds the service limit, replace the cylinder and the piston.

DATA Piston to cylinder clearance:

Standard: 0.045 – 0.055 mm (0.00177 – 0.00216 in)

Service Limit: 0.120 mm (0.0047 in)

PISTON PINS AND PIN BORE

- Measure the piston pin bore inside diameter using the small bore gauge.
- If the measurement is out of specification, replace the piston.

 09900-20802: Dial gauge (1/1000 mm)

09900-22401: Small bore gauge (10 – 18 mm)

DATA Piston pin bore I.D.:

Service Limit: 16.030 mm (0.6311 in)

- Measure the piston pin outside diameter at three positions using the micrometer.
- If any of the measurements are out of specification, replace the piston pin.

 09900-20205: Micrometer (0 – 25 mm)

DATA Piston pin O.D.:

Service Limit: 15.980 mm (0.6291 in)

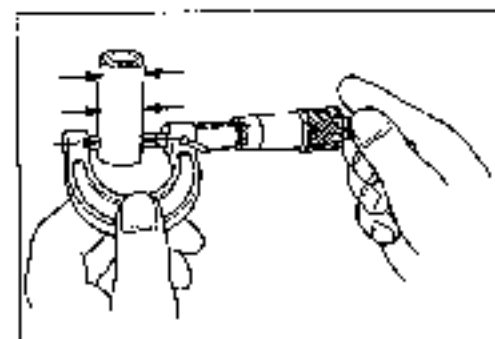
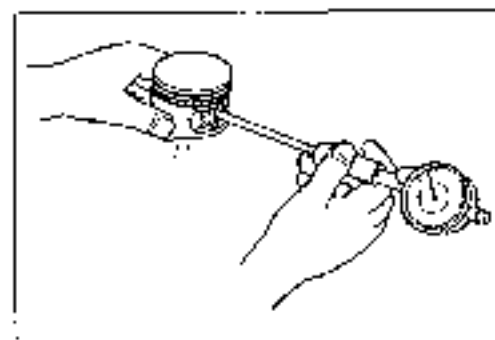

PISTON RING TO GROOVE CLEARANCE

- Measure the side clearances of the 1st and 2nd piston rings using the thickness gauge.
- If any of the clearances exceed the limit, replace both the piston and piston rings.

TRACO 09900-20803: Thickness gauge
09900-20205: Micrometer (0 - 25 mm)

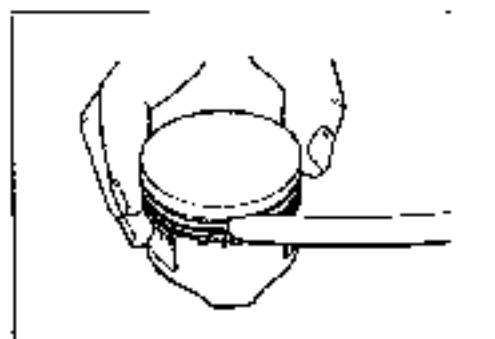

DATA Piston ring to groove clearance:
Service Limit (1st): 0.16 mm (0.0071 in)
(2nd): 0.15 mm (0.0059 in)

DATA Piston ring groove width:
Standard(1st): 1.01 - 1.03 mm (0.0398 - 0.0406 in)
(2nd): 1.01 - 1.03 mm (0.0398 - 0.0406 in)
(Oil): 2.01 - 2.03 mm (0.0791 - 0.0799 in)

DATA Piston ring thickness:
Standard (1st): 0.970 - 0.990 mm (0.03819 - 0.03898 in)
(2nd): 0.970 - 0.990 mm (0.03819 - 0.03898 in)

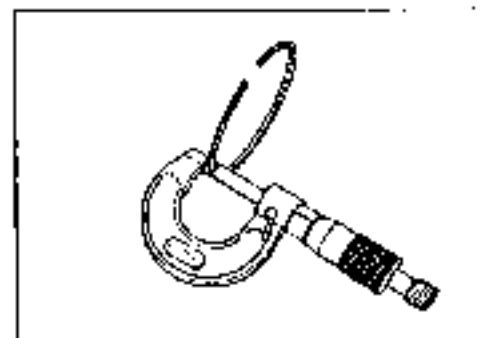
**PISTON RING FREE END GAP AND PISTON RING END GAP**

- Measure the piston ring free end gap using vernier calipers.
- Next, fit the piston ring squarely into the cylinder and measure the piston ring end gap using the thickness gauge.
- If any of the measurements exceed the service limit, replace the piston ring with a new one.

TRACO 09900-20102: Vernier calipers

DATA Piston ring free end gap:
Service Limit (1st): 9.3 mm (0.36 in)
(2nd): 6.9 mm (0.27 in)

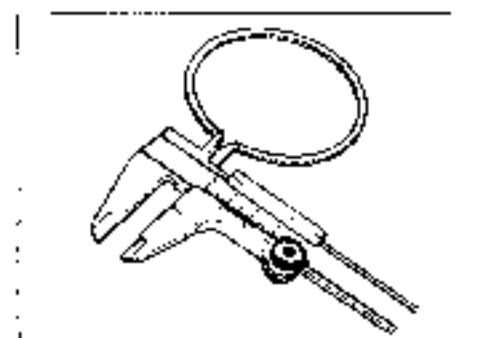

TRACO 09900-20803: Thickness gauge

DATA Piston ring end gap:
Service Limit (1st): 0.50 mm (0.020 in)
(2nd): 0.50 mm (0.020 in)

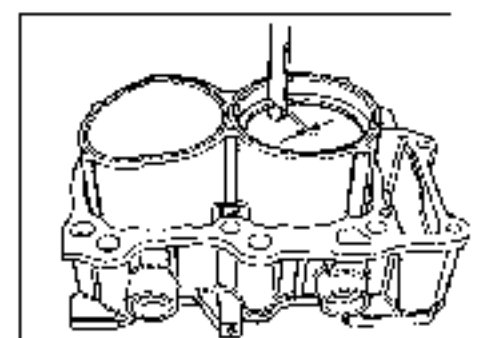

CLUTCH

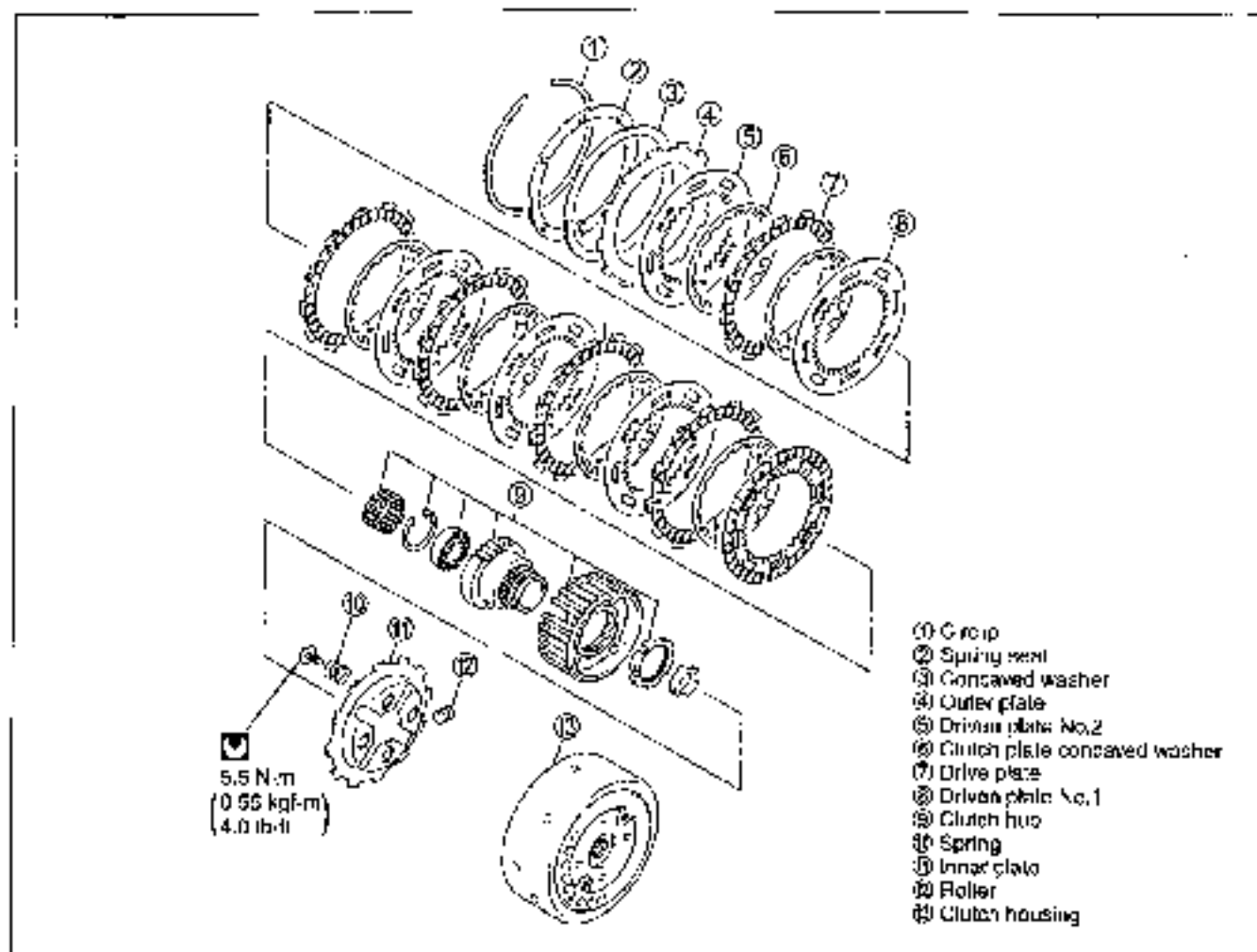

DISASSEMBLY

- Remove the circlip ① with the special tools.

 09920-33530: Clutch spring compressor

09924-84510: Bearing installer set

- Remove the clutch hub ⑨ and spacer.

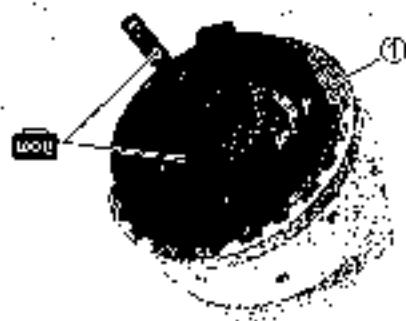

- Remove the spring seal and concaved washer.
- Remove the outer plate, driven plate No.1, clutch plate concaved washer, drive plate, and driven plate No.2.



- Remove the clutch spring bolts (2), spring (3) and clutch inner plate (4).



- Remove the roller.



CLUTCH DRIVE PLATES/CLUTCH DRIVEN PLATES NO.2 INSPECTION

NOTE:

Wipe off engine oil from the clutch drive plates with a clean rag.

- Measure the thickness of drive plates with a vernier calipers.
- If each drive plate thickness is less than the limit, replace it with a new one.

DATA Drive plate thickness:

Service Limit: 2.62 mm (0.095 in)

Driven plate No.2 thickness:

Service Limit: 2.27 mm (0.0894 in)

 09900-20102: Vernier calipers

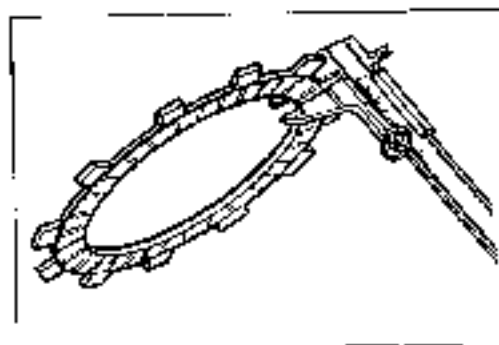

- Measure the claw width of drive plates with a vernier calipers.
- Replace the drive plates found to have worn down to the limit.

DATA Drive plate claw width:
Service Limit: 13.05 mm (0.5138 in)

 09900-20102: Vernier calipers

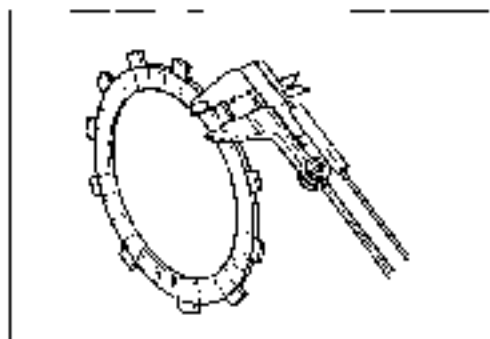

CLUTCH DRIVEN PLATE NO.2 INSPECTION

- Check for discoloration due to burning.
- Measure the distortion of the plate on the level block with a thickness gauge.
- If the service limit has been exceeded, replace with new one.

DATA Distortion of driven plate:
Service Limit: 0.1 mm (0.004 in)

 09900-20603: Thickness gauge

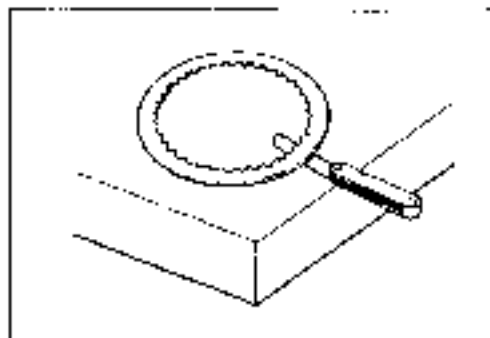

CLUTCH SPRING FREE HEIGHT

- Measure the free length of the clutch spring with vernier calipers.
- If the length is below the service limit, replace the spring.

DATA Clutch spring free length:
Service Limit: 13.2 mm (0.5197 in)

 09900-20102: Vernier calipers

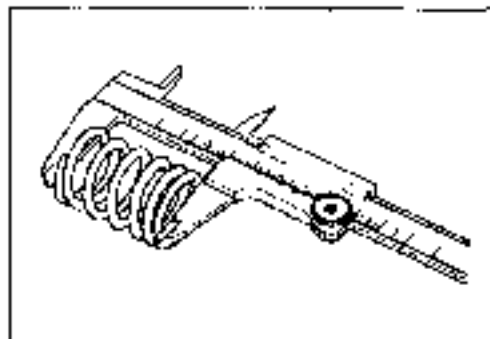

CLUTCH PLATE CONCAVED WASHER INSPECTION

- Measure the clutch plate concaved washer height (A) when applying the weight 9.8 N (1 kgf, 2.2 lb) as shown.
- If clutch plate concaved washer height is less than the limit, replace it with the new one.

DATA Clutch plate wave washer height:
Service Limit: 3.1 mm (0.12 in)

 09900-20102: Vernier calipers

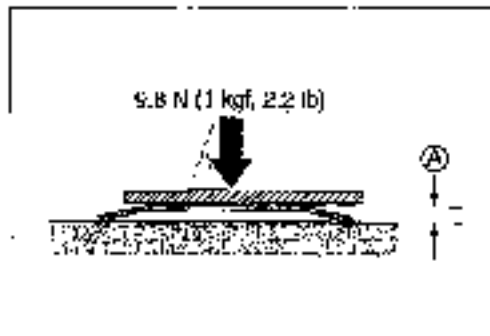

ROLLER

- Check that there is no abnormal wear or damage on the roller. If any defects are found, replace the rollers as a set.



REASSEMBLY**NOTE**

Reassemble the clutch in the reverse order of removal and disassembly. Pay attention to the following points:

- Install the roller.
- Tighten the clutch spring bolts to the specified torque.

 Clutch spring bolt: 5.5 N·m (0.55 kgf-m, 4.0 lb-ft)

- Install the spacer  and clutch sleeve hub.



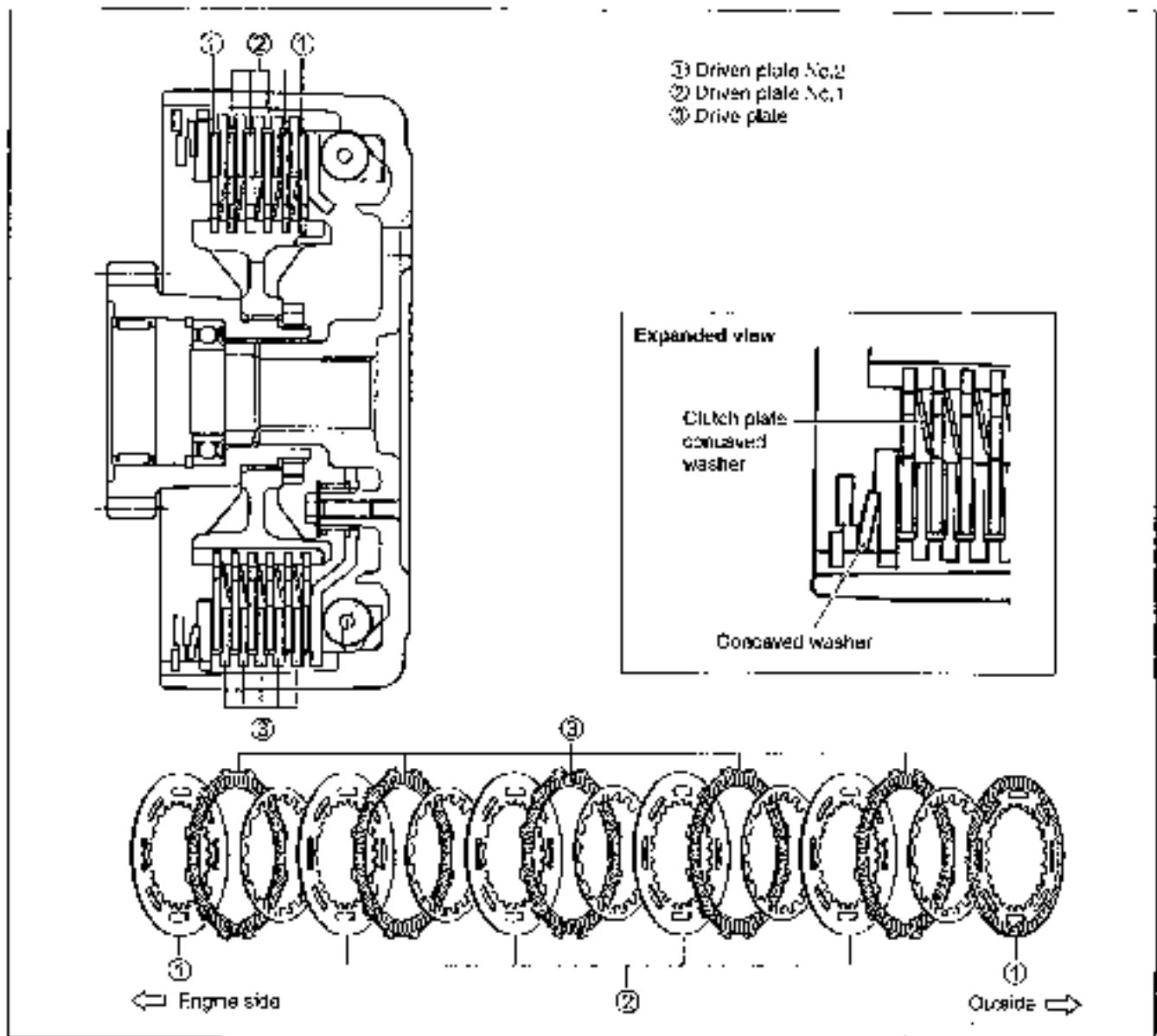

• Install the driven plate No.1, driven plate No.2, drive plate, clutch plate concaved washer outer plate, concaved washer, and spring seal

• Install the circlip with the special tools.

-  09920-33530: Clutch spring compressor
- 09924-84510: Bearing installer set

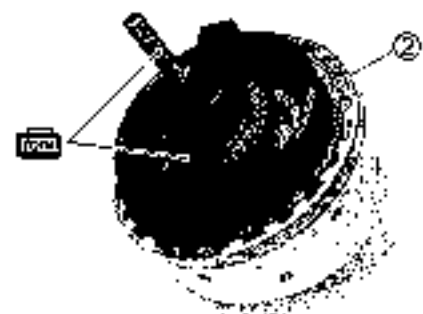

STARTER CLUTCH

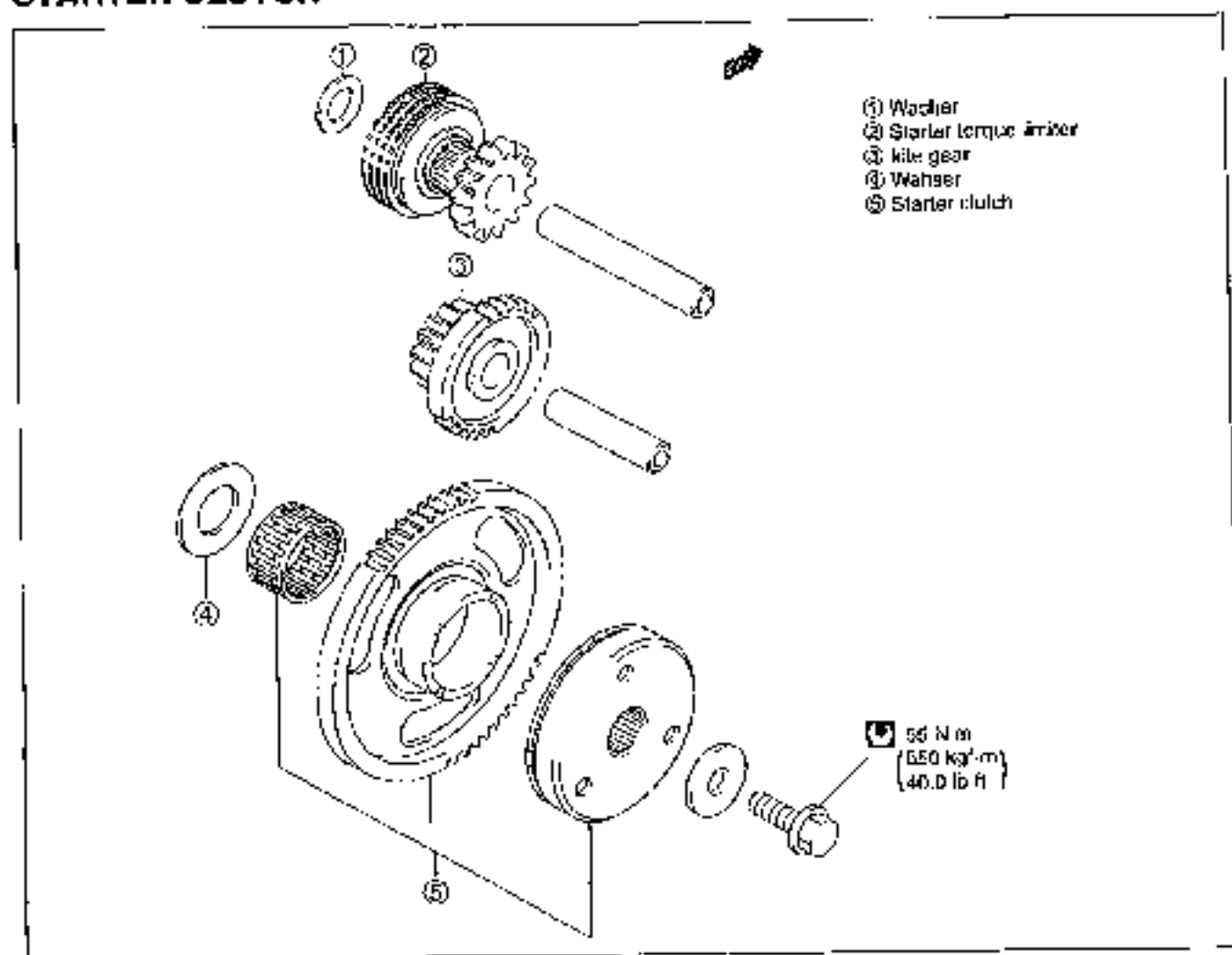

INSPECTION

- Install the starter driven gear onto the starter clutch.
- Turn the starter driven gear by hand.
- Inspect the starter clutch for a smooth movement.
- Inspect that the gear turns one direction only.



- If a large resistance is felt for rotation, inspect the starter clutch bearing or the starter clutch contacting surface on the starter driven gear for wear and damage.
- If they are found to be damaged, replace them with new ones.



STARTER TORQUE LIMITER

INSPECTION

- Measure the torque when slipping by means of the special tool and torque wrench.
- If the measurement result is out of standard value, replace with new one.

DATA Slip torque
standard: 22 – 41 N·m (2.2 – 4.1 kgf-m, 16 – 29.5 lb-ft)

TOOLS 09930-73170: Starter torque limiter holder
09930-73120: Starter torque limiter socket



OIL PUMP

INSPECTION

- Rotate the oil pump by hand and check that it moves smoothly.
- If it does not move smoothly, replace the oil pump assembly.

CAUTION

- * Do not attempt to disassemble the oil pump assembly.
- * The oil pump is available only as an assembly.



OIL PRESSURE REGULATOR/OIL SUMP FILTER

- Inspect the operation of the oil pressure regulator by pushing on the piston with a proper bar.
- If the piston does not operate, replace the oil pressure regulator with a new one.



- Check the oil sump filter for clogging and damage.
- If any fault is detected, clean or replace with new one.



CRANK BALANCER**DISASSEMBLY**

- Remove the circlip (1), washer (2), spring (3) and scissors gear (4).

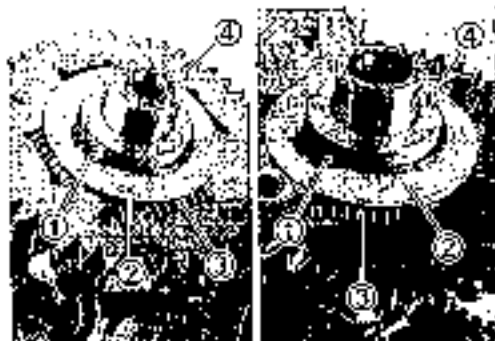
**REASSEMBLY**

- Carry out the assembly procedure in the reverse order of disassembly while observing the following instructions.
- Assemble the scissors gear with its punch mark side the outside.
- When assembling, align the balancer driven gear hole (A) with the scissors gear hole (B).
- Install the springs (5).
- Install the washer (6) and circlip (7).

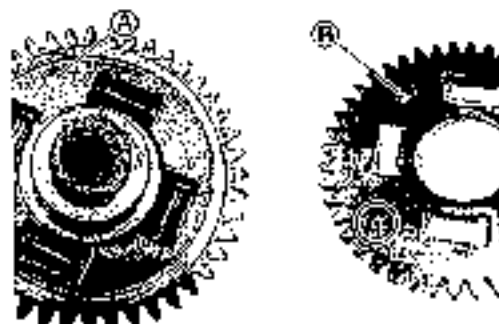
**DRIVE SHAFT****DISASSEMBLY**

- Remove the drive shaft nut.



- Remove the washer (8), spring stopper (9), dumper cam spring (10), cam dog (11), final driven gear (12), and drive shaft oil seal (13).

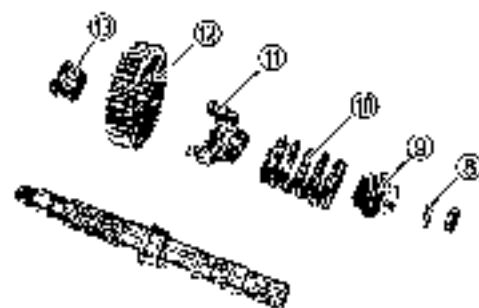

INSPECTION

- Check the disassembled components for any damage.
- Damaged cam dog
- Abnormal wear or damage of gear and spline

**ASSEMBLING****NOTE:**

Reassemble the components in the reverse order to disassembly taking care particularly about the following items:

- Coat the spline area of the cam dog (2) with grease.

 98000-25030: SUZUKI SUPER GREASE "A" (USA)

99000-25010: SUZUKI SUPER GREASE "A" (Others)

- Install the bush (1), final drive gear (2), cam dog (3), dumper spring (4), spring stopper (5), washer (6) and nut (7) to the drive shaft.

- Fix the drive shaft assembly to the vise and tighten the nut.

 Drive shaft nut: 105 N·m (10.5 kgf·m, 76.0 lb-ft)

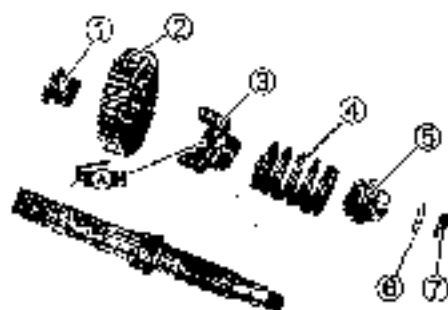

CONROD/CRANKSHAFT

CONROD SMALL END I.D.

- Using a small bore gauge, measure the inside diameter of the conrod small end.

TOOL 09900-20602: Dial gauge (1/1000 mm, 1 mm)

09900-22401: Small bore gauge (10 - 18 mm)

DATA Conrod small end I.D.:

Service Limit: 16.040 mm (0.6315 in)

- If the inside diameter of the conrod small end exceeds the limit, replace the conrod.

CONROD BIG END SIDE CLEARANCE

- Inspect the conrod side clearance by using a thickness gauge.
- If the clearance exceeds the limit, remove the conrod and inspect the conrod big end width and the crank pin width.
- If the width exceed the limit, replace conrod or crankshaft.

DATA Conrod big end side clearance:

Service Limit: 0.30 mm (0.012 in)

TOOL 09900-20803: Thickness gauge

DATA Conrod big end width:

Standard: 19.95 - 20.00 mm (0.7854 - 0.7874 in)

TOOL 09900-20205: Micrometer (0 - 25 mm)

DATA Crank pin width:

Standard: 20.10 - 20.15 mm (0.7913 - 0.7933 in)

TOOL 09900-20205: Micrometer (0 - 25 mm)

09900-20605: Dial caliper (10 - 34 mm)

09900-20803: Thickness gauge

CONROD-CRANK PIN BEARING INSPECTION

- Inspect the bearing surfaces for any sign of fusion, pitting, burn, or flaws. If any, replace them with a specified set of bearings.

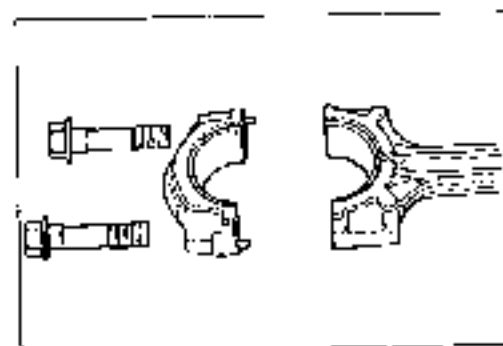
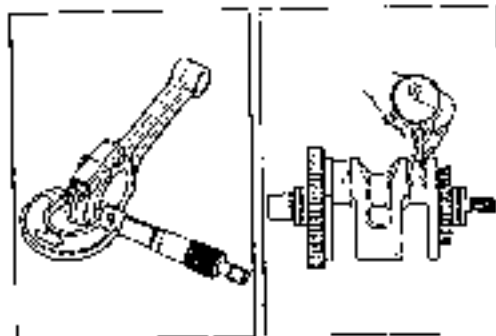
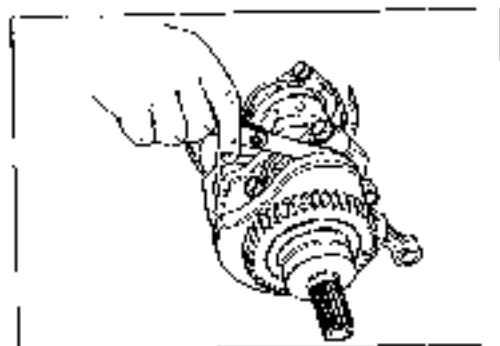
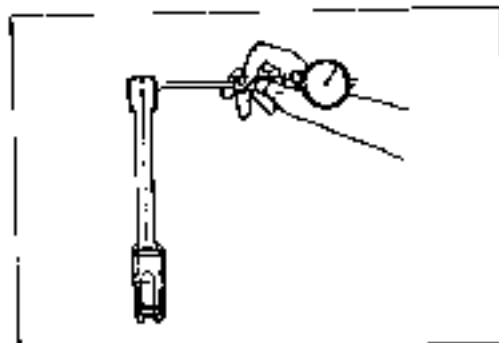

CONROD-CRANK PIN BEARING SELECTION

- Place the plastigauge axially along the crank pin, avoiding the oil hole, as shown

08900-22301: Plastigauge

- Tighten the conrod cap bolts to the specified torque, in two stages. (C/F 3-50)

CAUTION

- Apply engine oil to the bearing cap bolt.
- Never rotate the crankshaft or conrod when a piece of plastigauge is installed.

- Remove the bearing caps and measure the width of the compressed plastigauge using the envelope scale. This measurement should be taken at the widest part of the compressed plastigauge.

DATA Conrod big end oil clearance:

Standard: 0.032 – 0.056 mm (0.0013 – 0.0022 in)

Service Limit: 0.060 mm (0.0031 in)

- If the oil clearance exceeds the service limit, select the specified bearings from the bearing selection table.
- Check the corresponding conrod I.D. code number ("1" or "2") (A).

- Check the corresponding crank pin O.D. code number ("1", "2" or "3") (B).

DATA Bearing selection table

	Code	Crank pin O.D. (B)		
		1	2	3
Conrod I.D. (A)	1	Green	Black	Brown
	2	Black	Brown	Yellow

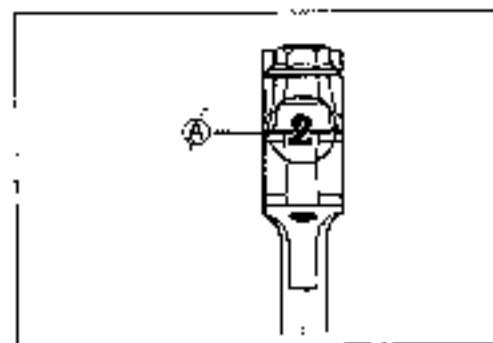
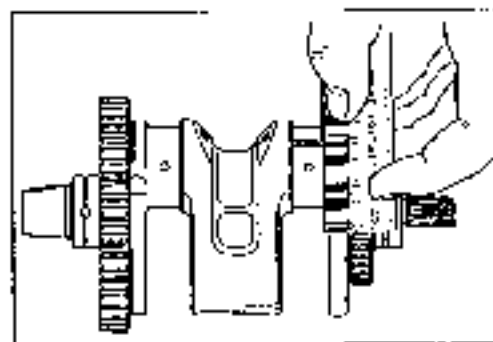
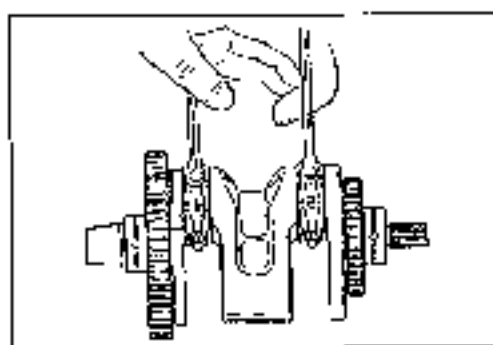
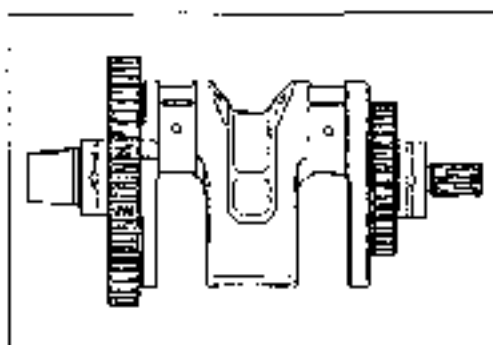

DATA Conrod I.D.

Code (A)	I.D. specification
1	48.000 – 48.008 mm (1.8898 – 1.8901 in)
2	48.006 – 48.016 mm (1.8901 – 1.8904 in)

DATA Crank pin O.D.

Code (B)	O.D. specification
1	44.992 – 45.000 mm (1.7713 – 1.7717 in)
2	44.984 – 44.992 mm (1.7710 – 1.7713 in)
3	44.976 – 47.984 mm (1.7707 – 1.7710 in)

max 09900-20202: Micrometer (25 – 50 mm)

DATA Bearing thickness

Color	Thickness
Green	1.480 – 1.484 mm (0.0583 – 0.0584 in)
Black	1.484 – 1.488 mm (0.0584 – 0.0586 in)
Brown	1.488 – 1.492 mm (0.0586 – 0.0587 in)
Yellow	1.492 – 1.496 mm (0.0587 – 0.0589 in)

CAUTION

The bearing must be replaced as a set.

BEARING ASSEMBLY

- When fitting the bearing to the bearing cap and conrod, be sure to fix the stopper part (A) first, and press in the other end.

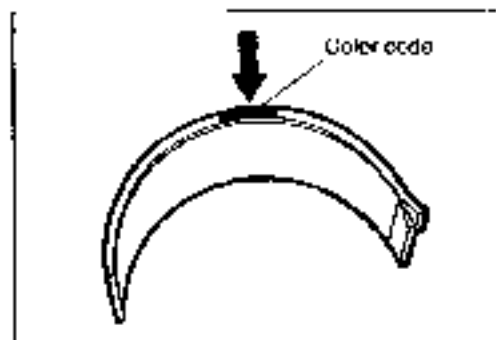

- Apply molybdenum oil solution to the crank pin and bearing surface.

MOLYBDENUM OIL SOLUTION

- When fitting the conrods on the crankshaft, make sure that I.D. (S) of the conrods face each cylinder intake valve sides.
- Apply engine oil to the bearing cap bolts.
- Tighten the bearing cap bolts as following two steps.

Conrod bearing cap bolt

(Initial) : 21 N·m (2.1 kgf·m, 15 lb-ft)

(Final) : After lightening the bolts to the above torque, tighten them $\frac{1}{4}$ of a turn (90°).

- Check the conrod movement for smooth turning

CRANKCASE-CRANKSHAFT BEARING INSPECTION

- Inspect the crankshaft journal bearings for any damage. If any, replace them with a specified set of bearings.

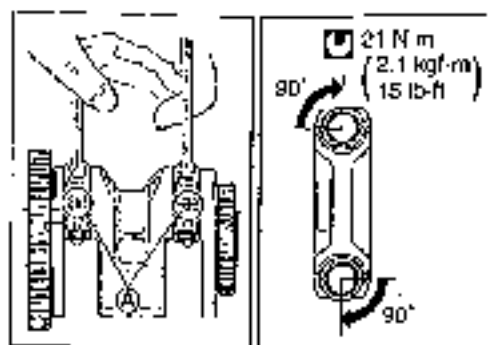

- Inspect the crankshaft journal for any damage.
- Measure the crankshaft journal O.D. with the spucial tool.

DATA Crankshaft journal O.D.

Standard: 47.985 – 48.000 mm (1.8882 – 1.8898 in)

 09900-20202: Micrometer (25 – 50 mm)

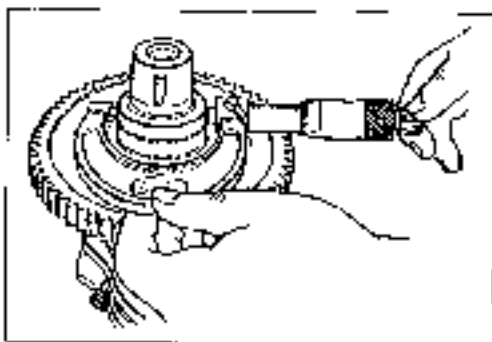

CRANKCASE-CRANKSHAFT BEARING SELECTION

Select the specified bearings from the crankcase bore I.D. code. The crankcase bore I.D. code (A) "A", "B" or "C", is stamped on the inside of each crankcase half.

I.D. code (A)	Color	Thickness
A	Green	1.988 – 1.991 mm (0.0783 – 0.0784 in)
B	Black	1.991 – 1.994 mm (0.0784 – 0.085 in)
C	Brown	1.994 – 1.997 mm (0.085 – 0.0786 in)



CRANKSHAFT JOURNAL BEARING REPLACEMENT

- Use the special tool to replace the crankshaft journal bearings. The replacement procedure is as follows.

09913-60230: Journal bearing remover/installer

- Set the special tool as shown to remove the crankshaft journal bearings.

NOTE:

Remove the crankshaft journal bearings in only one direction, from inside to outside of each crankcase half.

- Gradually press out the bearing with the special tool by using the hand-press.

CAUTION

The removed bearings must be replaced with new ones.

NOTE:

Using the hand-press is recommended to remove the crankshaft journal bearings. However, the crankshaft journal bearings can be removed by using with the following special tools.

- 09913-60230: ① Journal bearing remover/installer**
09924-94510: ② Bearing installer set
09924-74570: ③ Final drive gear bearing remover/installer

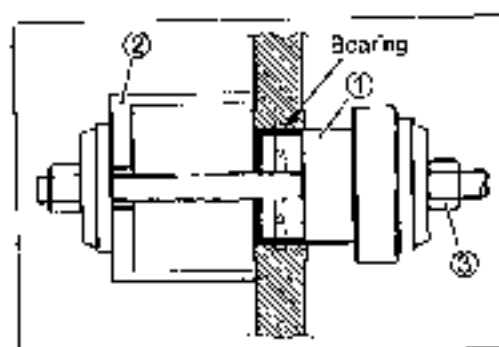
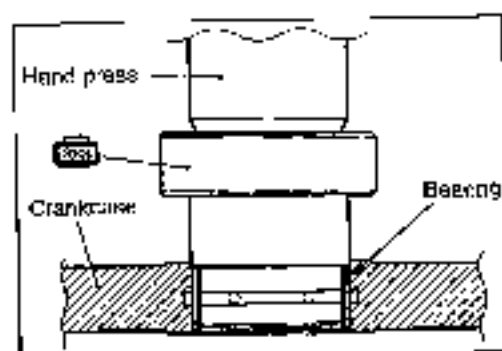

- Set the specified crankshaft journal bearings to the special tool.

 08913-60241: Journal bearing installer holder

CAUTION

- * Before setting the bearing, apply enough engine oil to the special tool and bearings.
- * When setting the bearing, align the bearing side with the engraved line **A** and also the bearing edge with the mating surface of the special tool.



- Tighten the special tool bolt to the specified torque.

 Special tool bolt: 23 N·m (2.3 kgf-m, 16.5 lb-ft)



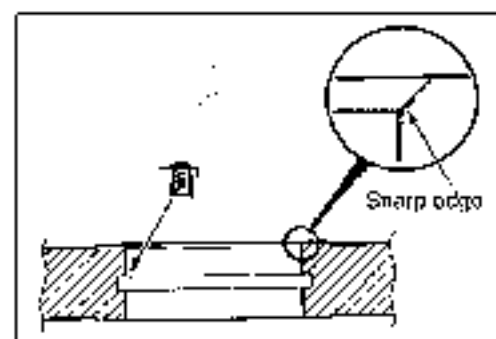

CAUTION

Before installing the bearings, lightly shave off the sharp edge part of the crankcase chamfer by using an oilstone and wash the crankcase bore with enough engine oil.





- Set the bearings installed in the special tool to the crankcase half as shown.

CAUTION

- Be sure the bearing protruded side  faces the crankcase bore.
- Align the special tool mating surface with the line mark  on the crankcase.



- Apply enough engine oil to the special tool and the bearings and then set the special tool carefully.
- Gradually press in the bearing into the main journal bore by using the hand-press until the special tool  or  stops the special tool .

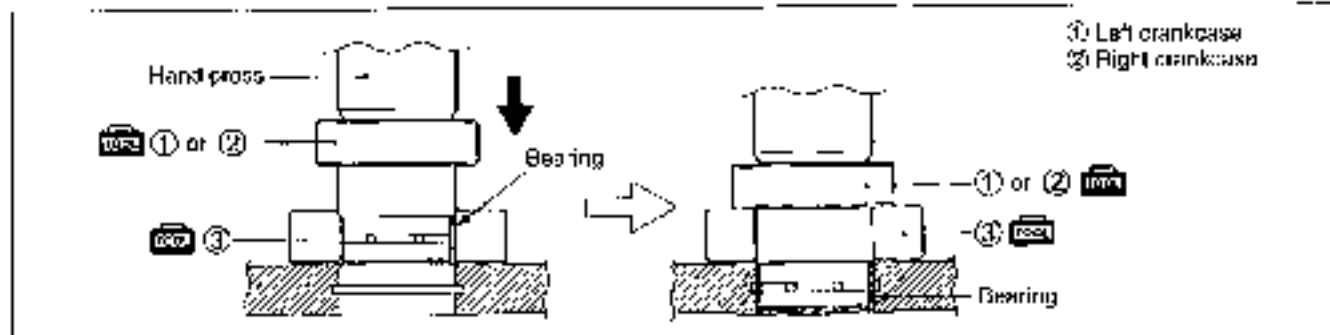

-  ① 09913-60210: Journal bearing remover/installer (Left crankcase)
-  ② 09913-60230: Journal bearing remover/installer (Right crankcase)
-  ③ 09913-60241: Journal bearing installer holder

**CAUTION**

Since the journal bearing press-fitting position is different between the right and left crankcases, use the correct installer respectively.

NOTE:



Using the hand-press is recommended to install the crankshaft journal bearings. However, the crankshaft journal bearings can be installed by using the following special tools.

CAUTION

Match the hole center of the special tool correctly.

 08924-84510: Bearing Installer

CRANKSHAFT THRUST CLEARANCE

- Face the oil groove (A) of the crankshaft shim (1) toward the crank web.
- Install the crankshaft to the crankcase. ( 3-62)
- Install the starter clutch. ( 3-64)

- Measure the gap between the thrust washer and crankcase.

DATA Crankshaft thrust clearance

Standard: 0.10 – 0.15 mm (0.004 – 0.006 in)

- If the thrust clearance is out of the standard range, replace the shim so that the standard value is obtained.

- To replace the shim, remove the thrust shim and measure the thickness. Select shims from the table below so that the standard value can be obtained.
- Inspect the crankshaft thrust clearance again.

Unit: mm (in)

Part number	Thrust shim thickness
09160-48005	2.025 – 2.050 (0.0797 – 0.0807)
09160-48006	2.050 – 2.075 (0.0807 – 0.0817)
09160-48007	2.075 – 2.100 (0.0817 – 0.0827)
09180-48008	2.100 – 2.125 (0.0827 – 0.0837)
09160-48009	2.125 – 2.150 (0.0837 – 0.0846)
09160-48010	2.150 – 2.175 (0.0846 – 0.0856)

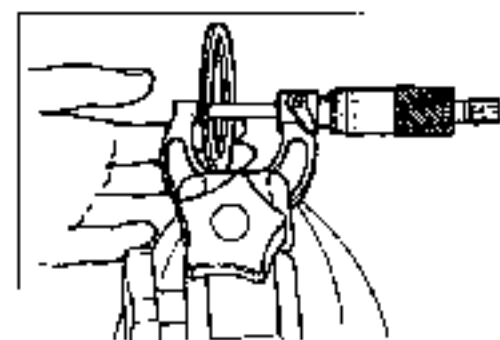
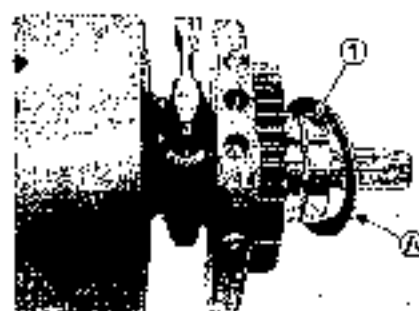
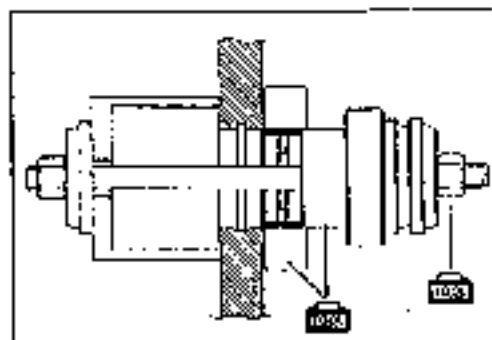

OIL JET

- Check the oil jets for clogging.

NOTE:

Before fitting, coat the O-ring with engine oil. Use a new O-ring. Note the carved mark not to mistake the size.

**NOTE:**

The oil jet are identified by engraved letters 8.

**NOTE:**

The oil jet are identified by engraved letters 14.

**PISTON COOLING NOZZLE**

- Check the piston cooling nozzle for clogging or deformation

NOTE:

Before installing, coat the O-ring with engine oil. Use new O-rings.

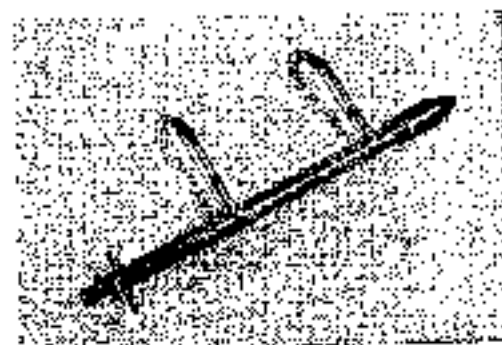

CRANKCASE

OIL PRESSURE SWITCH

- Remove the oil pressure switch.

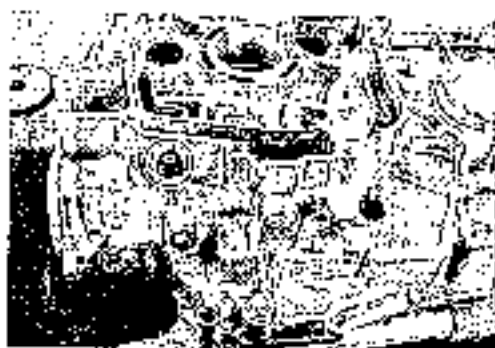

- When installing the switch, apply SUZUKI BOND "1207B".

 Oil pressure switch: 13 N·m (1.3 kgf·m, 10.0 lb-ft)

 99104-31140: SUZUKI BOND "1207B" (USA)

99000-31140: SUZUKI BOND "1207B" (Others)

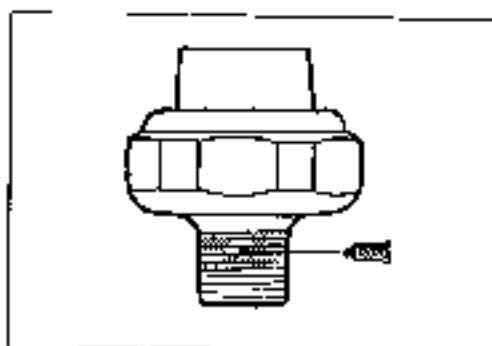

- Remove the right crankcase cover ①.
- Remove the primary shaft cap ②.
- Install the right crankcase cover ①, and primary shaft cap ②.

 Right crankcase cover bolt: 11 N·m (1.1 kgf·m, 8 lb-ft)

Primary shaft cap bolt: 11 N·m (1.1 kgf·m, 8 lb-ft)

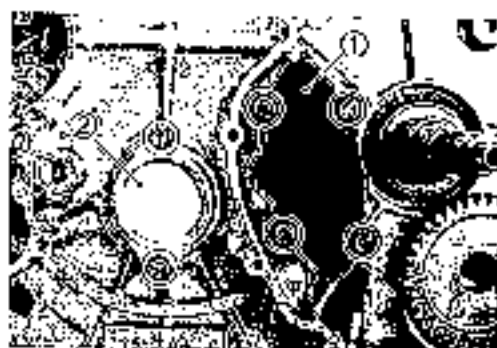

BEARING DISASSEMBLY

- Remove the bearing with the special tool.

 09921-20240: Bearing remover set ①

09941-54911: Bearing outer race remover ②

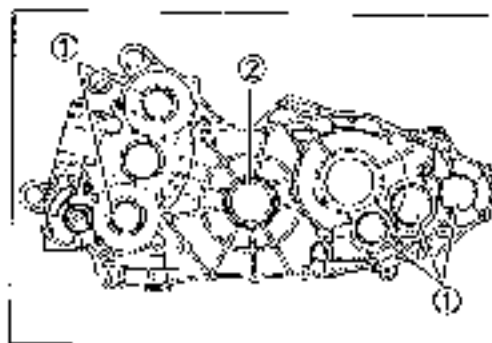
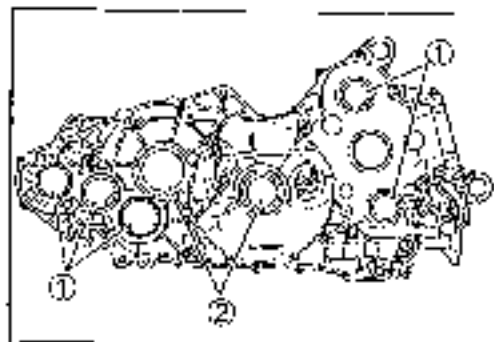

BEARING INSPECTION

Rotate the bearing inner race by finger to inspect for abnormal play, noise and smooth rotation while the bearings are in the crankcase.

Replace the bearing in the following procedure if there is anything unusual.

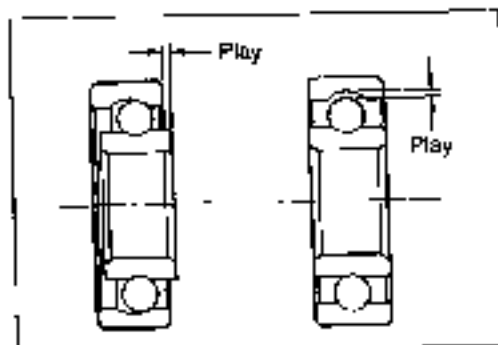
**BEARING REASSEMBLY**

- Install the bearing into the crankcase with the special tool.

 09913-70210: Bearing installer set

OIL SEAL DISASSEMBLY

- Remove the oil seal with the special tools.

 (1) 09913-70210: Bearing remover set
(2) 08913-06210: Bearing remover

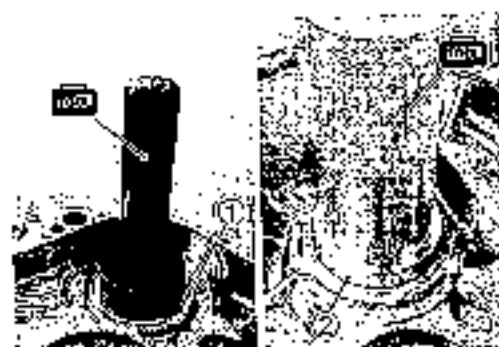

 08913-50121: Oil seal remover

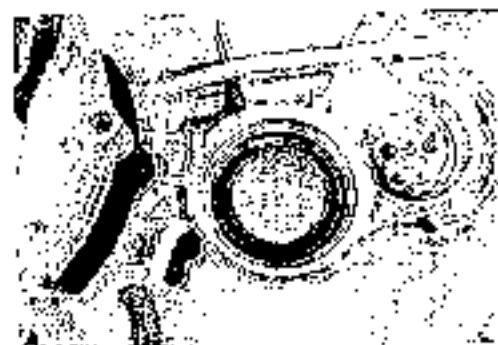

OIL SEAL REASSEMBLY

- Apply grease to the oil seal lip.

 89000-25030: SUZUKI SUPER GREASE "A" (USA)
89000-25010: SUZUKI SUPER GREASE "A" (Others)

- Install the oil seal with the special tool.

 09913-70210: Bearing installer set

CAUTION

Use a new Oil seal.

- Assembling of bush.
- Assemble the engine mount bush.

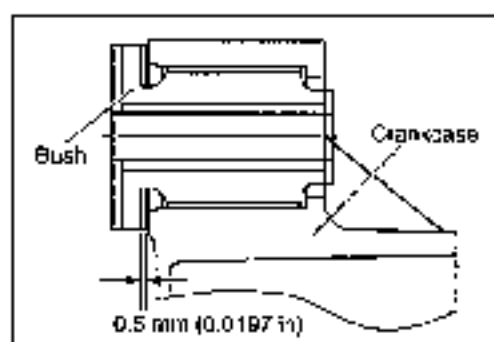
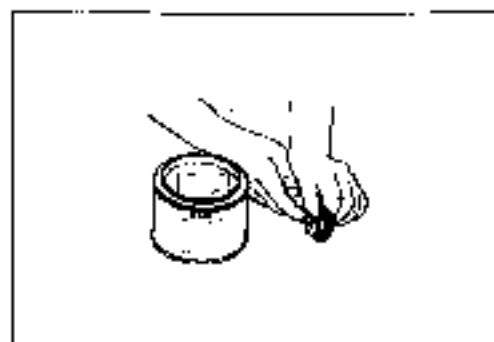

ENGINE REASSEMBLY

- Reassemble the engine in the reverse order of disassembly.
- The following steps require special attention or precautionary measures should be taken.

NOTE:

Apply engine oil to each running and sliding part before reassembling.

RETURN OIL PUMP

- Install the return oil pump and insert the pin (1) into the shaft.
- Install the pin aligning to the groove of the return oil pump gear and fit a circlip.



PRIMARY DRIVEN GEAR/ CRANKSHAFT

- Install the primary driven gear (2), crankshaft (3).



- Install the crankcase oil separator.



OIL SUMP FILTER

- Install the oil strainer aligning the recess of the oil strainer to the concave on the crankcase.



PISTON COOLING NOZZLE

- Coat the O-ring with a small amount of grease and install the piston cooling nozzle (1).



OIL PUMP/ OIL PRESSURE REGULATOR

- Install the oil pump (2), washer (3), pin (4).



- Coat the O-ring with grease and install the oil pressure regulator (5) to the crankcase.



CAUTION

Use a new O-ring.

CRANK BALANCER SHAFT

- Install the upper crank balancer shaft (1).
- Install the lower crank balancer (2), oil pump drive gear (3), and oil pump drive chain (4).
- Check that the oil pump drive gear recess and pin are matched and fit the circlip (5).

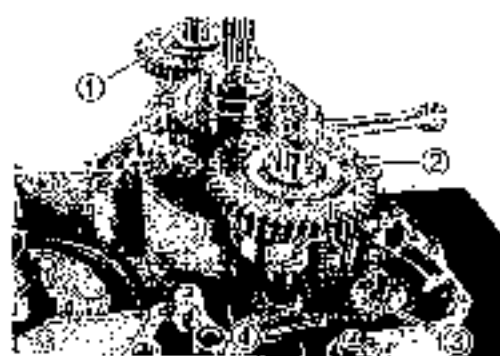
**CAUTION**

Check that the punched mark on the balancer drive gear and that on the balancer drive gear are aligned.

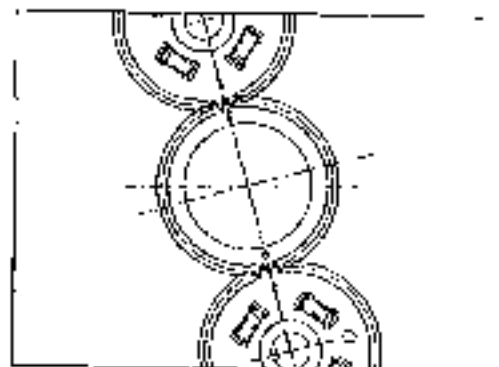
**DRIVE SHAFT**

- Install the counter drive shaft (6) from the outside, install the counter drive gear (7) and fit the circlip.

CAUTION

Check that the circlip is positively fitted.

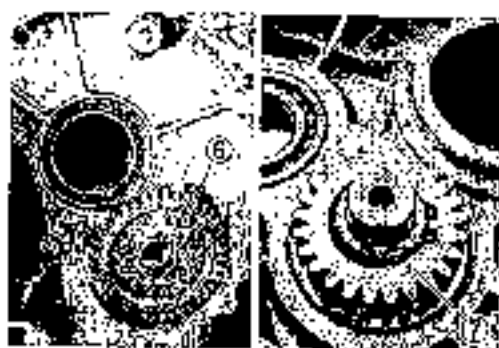

- Install the idle gear (8), idle shaft (9), and drive shaft assembly (10).

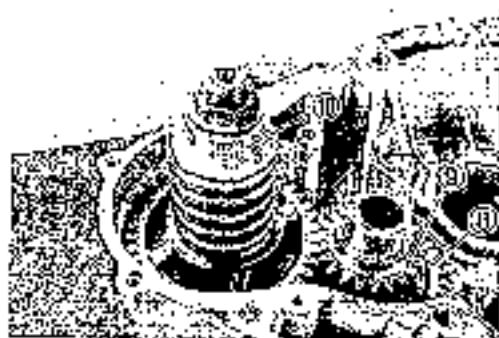

CRANKCASE

- Install the dowel pin.
- Coat the gear and bearing with engine oil before mating the crankcase.

- Coat the O-ring (1) with grease and fit the O-ring to the crankcase.

 99000-25030: SUZUKI SUPER GREASE "A"

- Install the spacer (2).

CAUTION

Use a new O-ring.

- Clean the mating surfaces of the left and right crankcase halves.
- Apply SUZUKI BOND to the mating surface of the right.

 99104-31140: SUZUKI BOND "1207B" (USA)

 99000-31110: SUZUKI BOND "1215" (Others)

CAUTION

- Coat the sealing agent quickly in uniform thickness without interruption.
- Be careful when coating the sealing agent not to allow it to enter the oil hole, bearing, etc.

- Install the crankcase and tighten the bolts diagonally and uniformly.

 Right crankcase bolt (M6): 11 N·m (1.1 kgf-m, 8 lb-ft)

 Left crankcase bolt (M8): 26 N·m (2.6 kgf-m, 19 lb-ft)

NOTE:

After tightening the crankcase bolt, check that the crankshaft rotates smoothly.

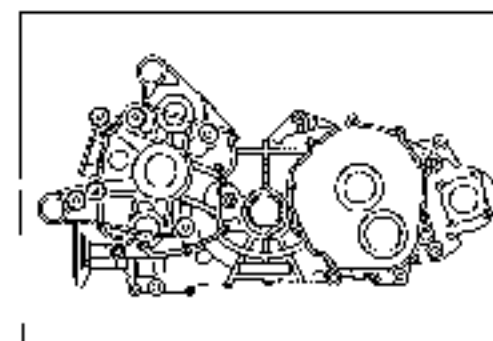
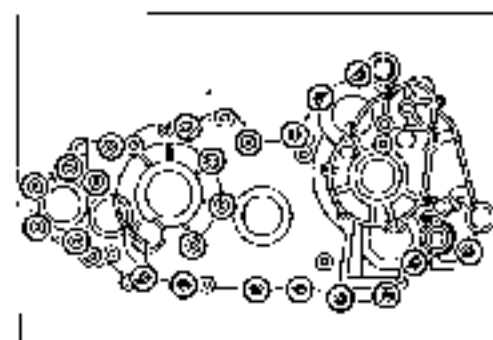
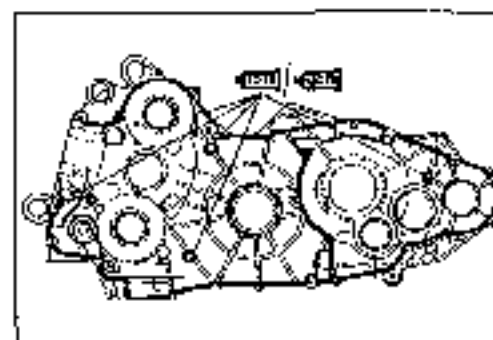
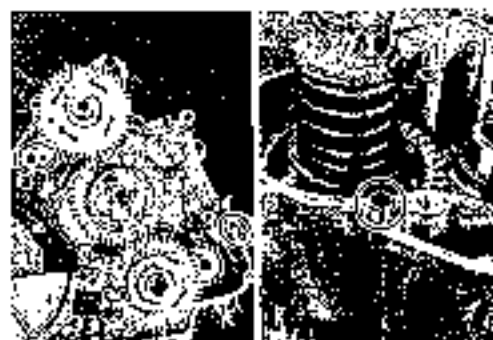

OIL COOLER

- Coat the O-ring with engine oil and install the oil cooler.
- Install the oil cooler to the crankcase and tighten the washer (1) and union bolt (2).

 Oil cooler union bolt: 70 N·m (7.0 kgf·m, 50.5 lb-ft)

NOTE:

Use a new O-ring.

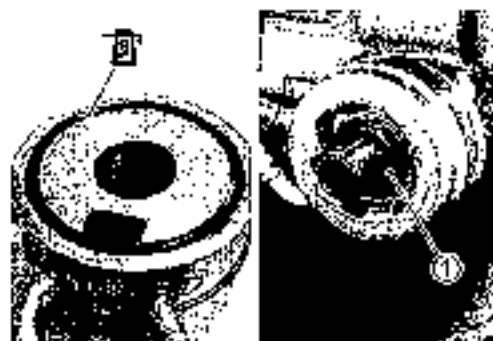
**WATER PUMP**

- Install the washer pump assembly.

**CAM CHAIN**

- Install the cam chain sprocket.

NOTE:

Align the punched mark on the crankshaft and that of the cam chain sprocket.

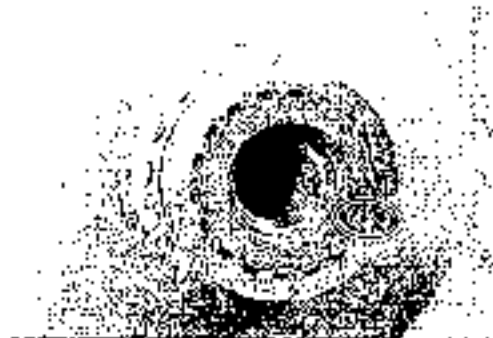

- Coat the washer (1) and cam chain tensioner bolt with Thread Lock and tighten them.

 99000-32050: THREAD LOCK "1342"

- Install the cam chain (4).



STARTER CLUTCH

- Install the washer (1).



- Coat the internal surface of the starter clutch gear and crankshaft with engine oil.
- Install the starter clutch assembly to the crankshaft.

NOTE:

Align the carved line (2) of the starter clutch and the punched mark (3) of the crankshaft.



- Tighten the starter clutch bolt together with the washer (2).
- Using the special tool, tighten with the specified torque.

Tool D9920-34830: Starter clutch rotor holder

Wrench Starter clutch bolt: 55 N·m (550 kgf·m, 40.0 lb-ft)



- Install the starter torque limiter shaft (1) and washer (2).
- Install the starter torque limiter (3), starter idle gear shaft (4) and the starter idle gear.

MO MOLYBDENUM OIL

CAUTION

Coat the crankcase bearing with a sufficient amount of molybdenum oil.

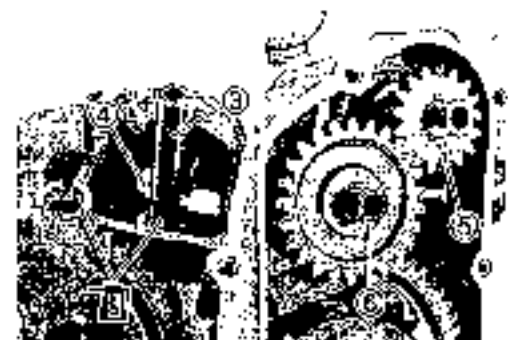

- Install the gasket (1) and dowel pin.



- Coat the starter clutch cover bearing with molybdenum oil.

MOLYBDENUM OIL SOLUTION

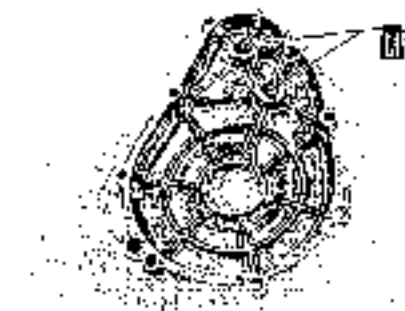

- Install the starter clutch cover.

NOTE:

Tighten the starter clutch cover bolt (2) together with the clamp.

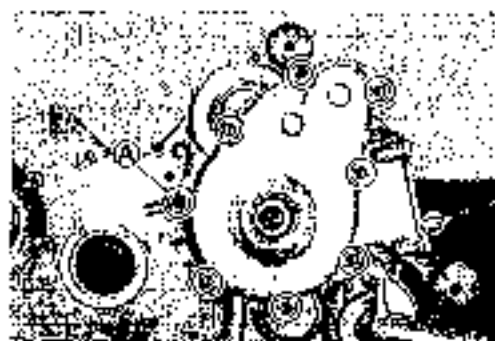

- Coat the drive shaft oil seal retainer with grease and install.
- Install the drive shaft oil seal retainer to the crankcase.

U Drive shaft oil seal retainer bolt:
 22 N·m (2.2 kgf-m, 16.0 lb-ft)

NOTE:
 Use a new O-ring.

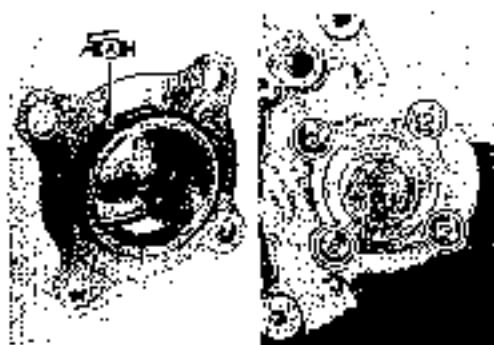

CLUTCH

- Install the clutch shaft to the clutch assembly.
- Coat the part **A** of the clutch shaft with SUZUKI MOLY PASTE.

99000-25140: SUZUKI MOLY PASTE

- Install the clutch assembly, washer (1), and clutch housing nut (2) to the left crankcase.
- Using the special tool, tighten the clutch housing bolt and nut with the specified torque.

09930-40113: Rotor holder

U Clutch housing nut: 70 N·m (7.0 kgf-m, 5 lb-ft)

- Install the gasket (3) and dowel pin.

- Install the clutch cover.

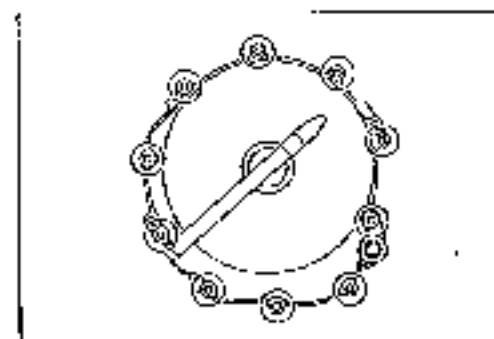
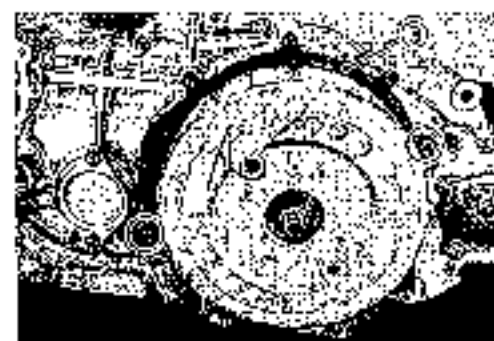
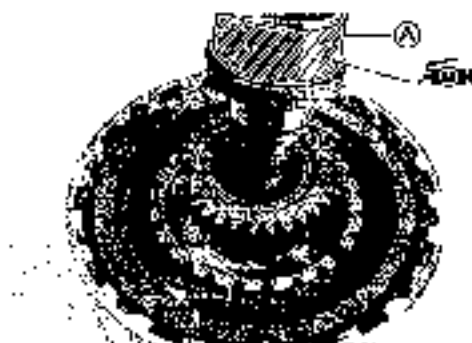

GENERATOR

- Remove the grease from the tapered part of the crankshaft.
- Install the key.



- Install the stator coil (1) and CKP sensor (2).
- Fit the grommet firmly.

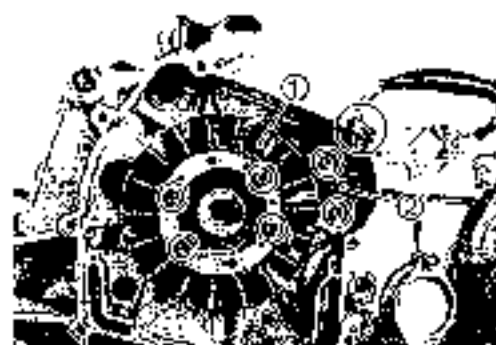

- Using the special tool, tighten the generator rotor nut with the specified torque.

PRO 09930-40113: Rotor holder

T Generator rotor bolt: 160 N·m (16.0 kgf-m, 115.5 lb-ft)



- Install the oil strainer.

NOTE:

Match the projection of the oil strainer and the groove at the recess of the crankcase.



- Install the gasket.

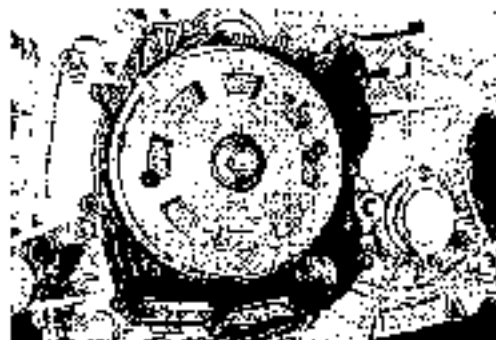

- Install the generator cover.

NOTE:

Tighten the generator cover bolt (A) together with the clamp.

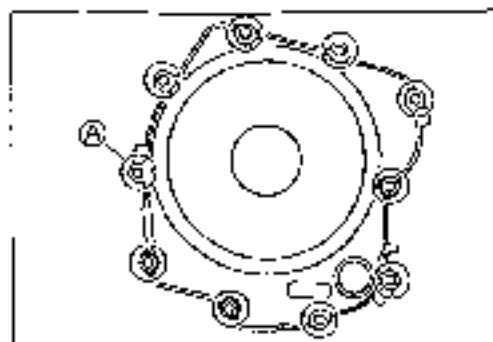

- Fit the washer (3) and union bolt to the oil hose (1) and oil return hose (2).

NOTE:

Use a new washer.

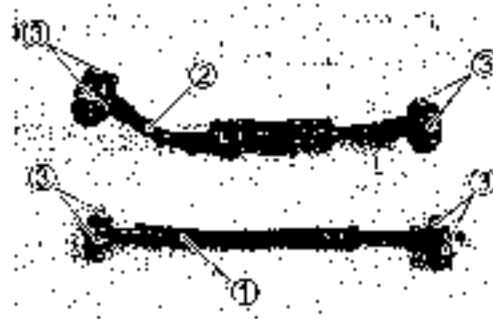

- Connect the oil hose and oil return hose to the crankcase.

- **Oil hose union bolt: 20 N-m (2.0 kgf-m, 14.5 lb-ft)**
- **Oil return hose union bolt: 28 N-m (2.8 kgf-m, 20.0 lb-ft)**

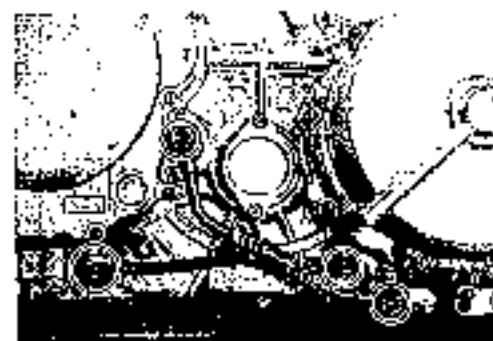

PISTON RING

- Install the piston rings in the order of the oil ring, second ring and top ring.
- Install the spacer ① of the oil ring first and then the side rail ②.

CAUTION

- When installing the spacer, be careful so that the both edges are not overlapped.
 - When installing the piston ring, be careful not to damage the piston.
 - Do not expand the piston ring excessively since it is apt to be broken down.
- Be careful not to mistake the second ring ③ and the top ring ④, the sectional form is different.
- Face the side with the stamped mark upward when assembling.

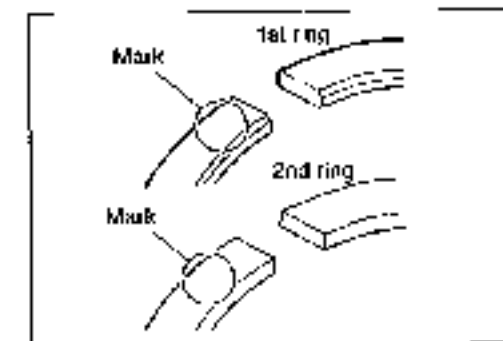
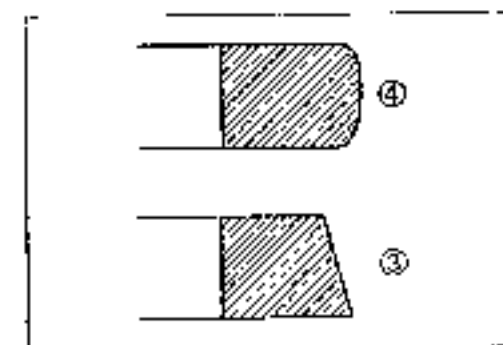
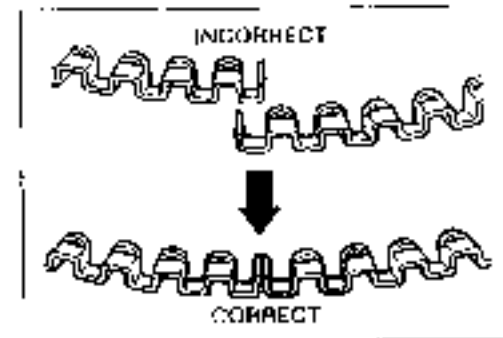
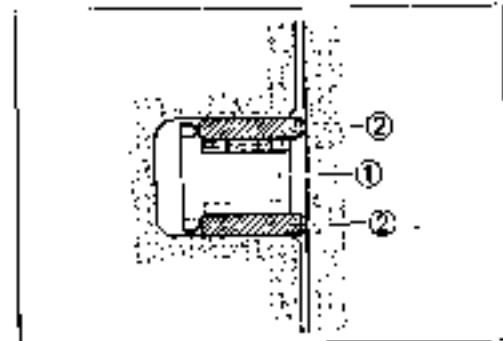

- After installing all the piston rings, check that each ring rotates smoothly.
- To prevent poor compression or oil leaking up to the cylinder inside, position each ring end gap as shown in the right figure.
 - Ⓐ Second ring / side rail (lower side)
 - Ⓑ Side rail (upper side)
 - Ⓒ Top ring / spacer

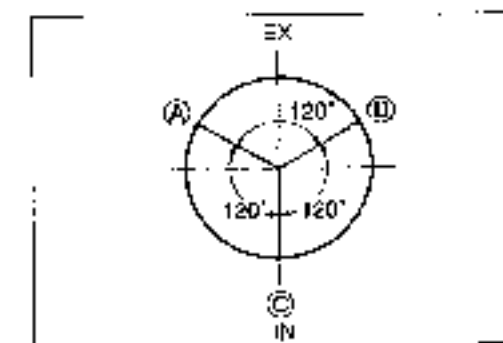

PISTON

- Coat the outer periphery of the piston pin and connecting rod small end with molybdenum oil.

2 MOLYBDENUM OIL SOLUTION

- Facing the ● mark on the piston head to the exhaust side of the cylinder, install the piston (1).



- Spread cloth under the piston and fit the circlip (2).

CAUTION

Use a new circlip.

CYLINDER

- Coat the connecting rod big end with oil.
- Install the dowel pin (1) and cylinder gasket (2).

CAUTION

Use a new gasket.



- Coat the cylinder inside surface and the piston ring with engine oil and install the cylinder.

CAUTION

Keep the cam chain pulled out not to be caught between the sprocket and crankshaft.



CYLINDER HEAD

- Install the dowel pin (1), cylinder head gasket (2) and the cam chain guide (3) to the cylinder.

CAUTION

Use a new gasket.



- Coat the thread of the cylinder head bolt with engine oil.
- Tighten the cylinder head bolt (1) and (2) in the order of the No. as illustrated.
- Tighten the bolts in 2 steps; lightly first and then firmly.

🔩 Cylinder head bolt (M10), (1), (2)

Light tightening: 25 N·m (2.5 kgf-m, 18.0 lb-ft)

Final tightening: 53 N·m (5.3 kgf-m, 38.5 lb-ft)

NOTE:

Bolt (1): 150 mm

Bolt (2): 155 mm

- Tighten the cylinder head bolt (3).

🔩 Cylinder head bolt (M8) (3): 25 N·m (2.5 kgf-m, 18.0 lb-ft)

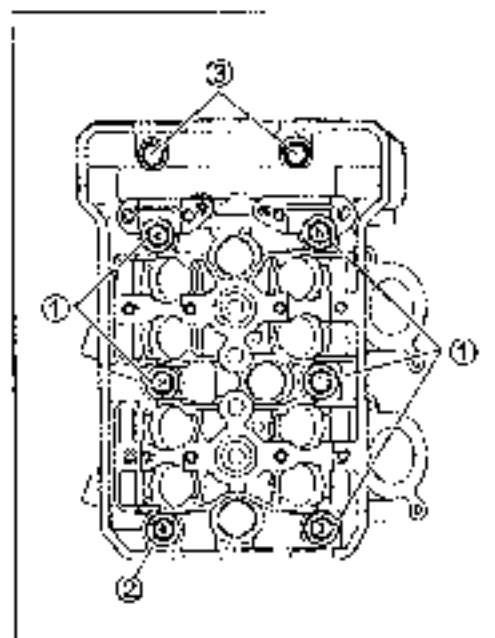

- Unlock the ratchet of the cam chain tensioner adjuster and push and compress the tensioner rod.
- Insert the special tool into the gap between the tensioner adjuster body and ratchet.
- Assemble the cam chain tensioner adjust bolt (4) and the copper washer (5).

🔧 09918-63810: Tensioner locking tool

🔩 Cam chain tensioner adjust bolt:

10 N·m (1.0 kgf-m, 7.3 lb-ft)

NOTE:

Use a new copper washer.

- Coat the both sides of the washer (5) with engine oil.
- Tighten the cylinder head side bolt.

🔩 Cylinder head side bolt: 14 N·m (1.4 kgf-m, 10.0 lb-ft)

NOTE:

Face the metal part of the washer outward.

Pass the cylinder head side bolt through the cam chain

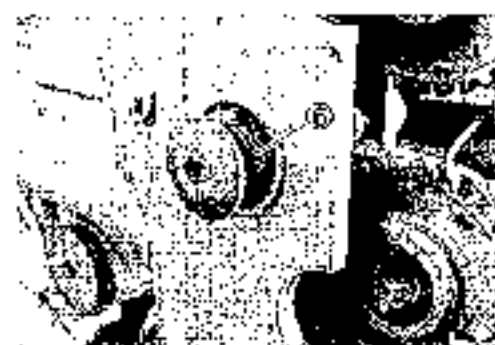

CAM SHAFT

- Turn the crankshaft in the forward direction and bring the piston to the top dead center. (→ 2-8)



- Before installing the cam shaft to the cylinder head, coat the journal, cam surface and camshaft journal holder with molybdenum oil.

MOLYBDENUM OIL**NOTE:**

Before installing the cam shaft, check that the tappet is properly installed.

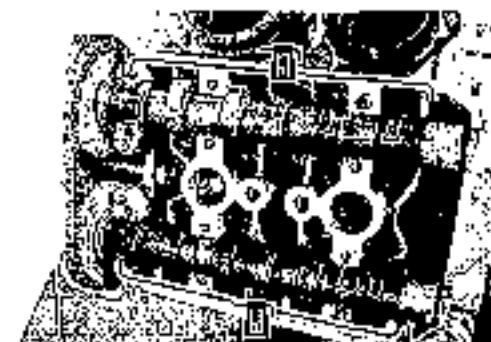

- The exhaust cam shaft and intake cam shaft are distinguished by the identification mark on the sprocket.

Exhaust camshaft: "B"

Inlet camshaft: "A"

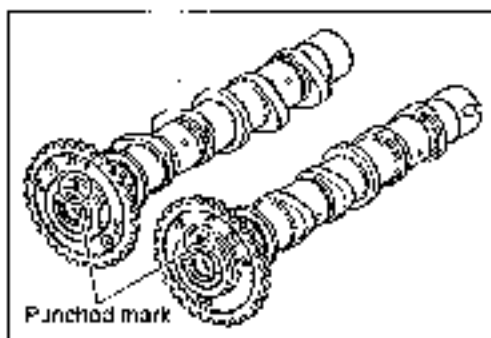

- Match the arrow mark (→) on the exhaust cam shaft 1 to the cylinder head top surface.

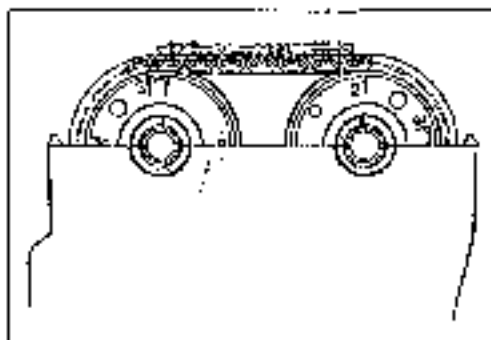

- Match the arrow mark of the Inlet cam sprocket 3 to the roller pin to pin 15 position on the arrow mark of the exhaust cam sprocket 2.

NOTE:

Do not move the crankshaft until the camshaft journal holder and cam chain tensioner adjuster are fixed.

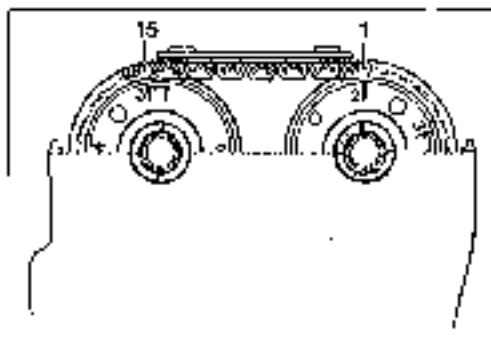

POSITION OF CAMSHAFTS AND SPROCKETS

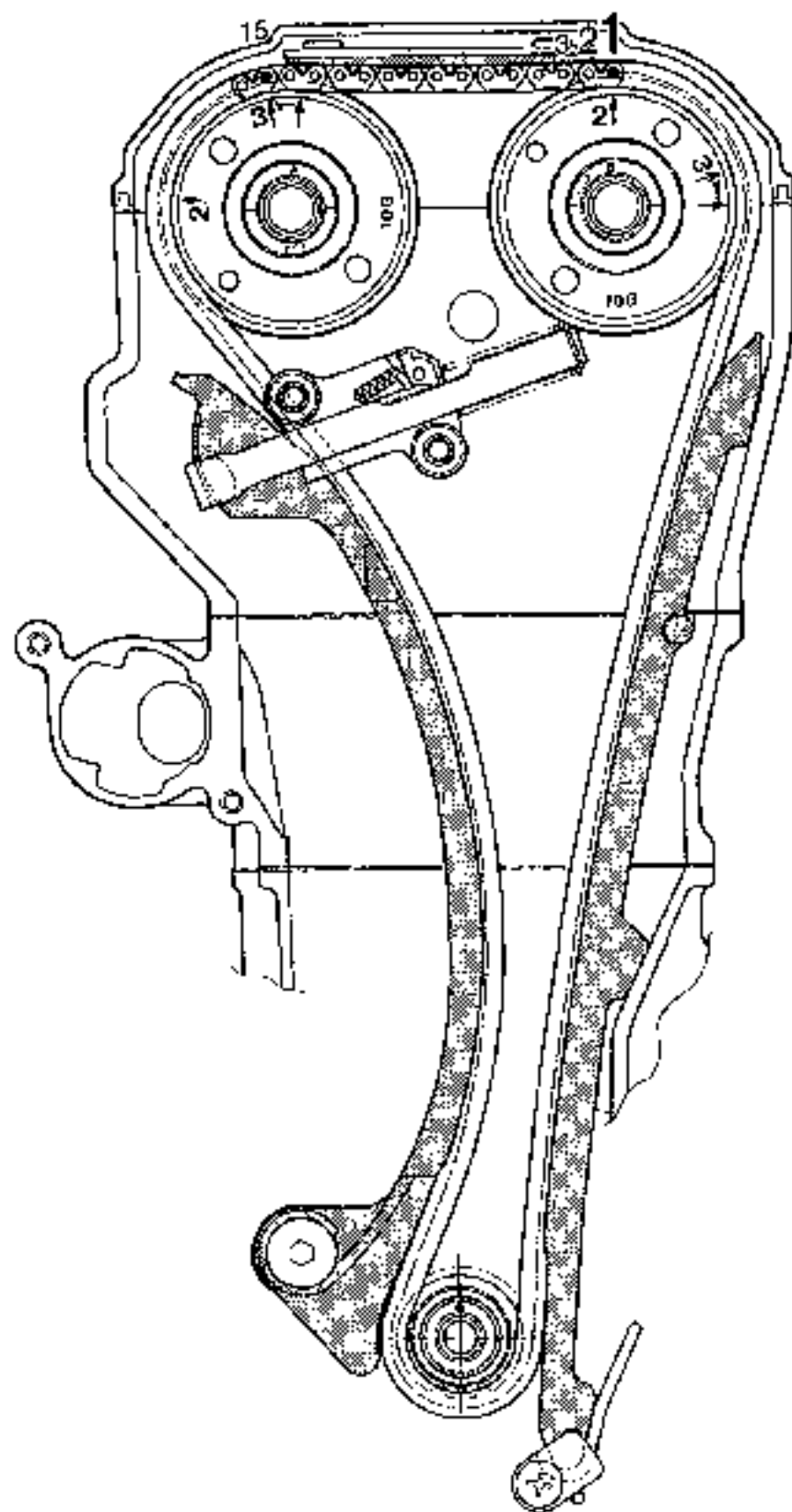

- Install the dowel pin.

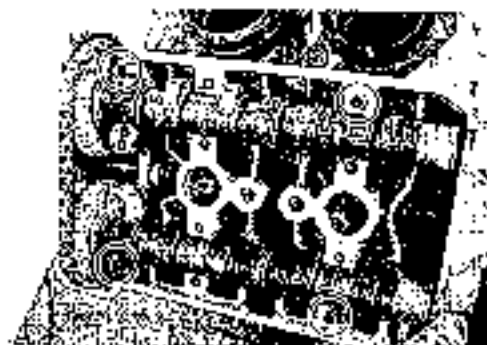

- Install the camshaft holder and cam chain guide.
- Arrange the cam shaft holder by hand so that it is positioned at 1 – 2mm from the cylinder head mating surface.
- Tighten the cam shaft holder bolts in the order shown by the embossed figures on the camshaft holder.

- 🔧 Cam shaft holder bolt ①: 10 N·m (1.0 kgf-m, 0.7 lb-ft)
- Cam shaft holder bolt ②: 10 N·m (1.0 kgf-m, 0.7 lb-ft)

NOTE:

Install the camshaft holder to the correct positions according to the identification marks

Intake camshaft: IN

Exhaust camshaft: EX

- Unlock the cam chain tensioner.

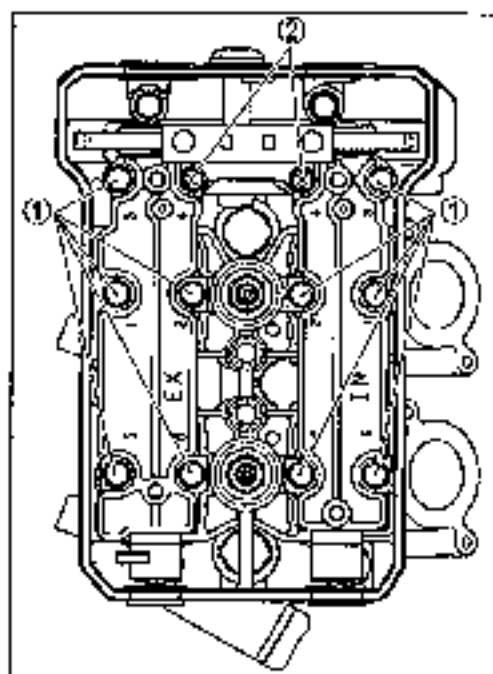

CYLINDER HEAD COVER

- Assemble the gasket to the cylinder head cover.
- Coat the semicircular part of the gasket with sealing agent.

🔧 99000-31230: SUZUKI BOND "1216B"

NOTE:

Do not remove the dowel pin at the back of the cylinder head since it is embedded.

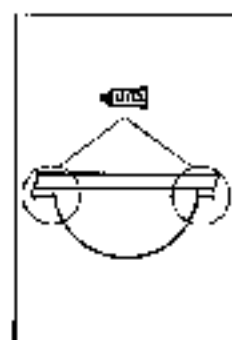

- Install the cylinder head cover.
- Coat the both sides of the washer ③ with engine oil and tighten the head cover bolt together with the washer.

- 🔧 Cylinder head cover bolt
- Light tightening: 10 N·m (1.0 kgf-m, 7.0 lb-ft)
- Final tightening: 14 N·m (1.4 kgf-m, 10.0 lb-ft)

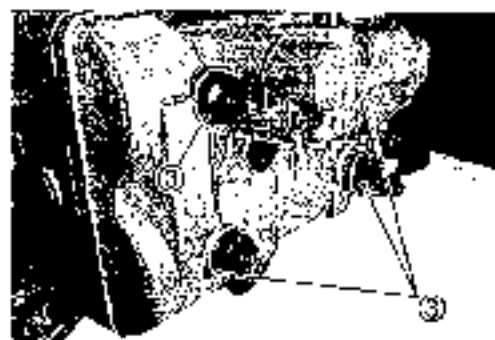

OIL LEVEL SWITCH

- Install the oil level switch.

 Oil level switch bolt: 10 N·m (1.0 kgf-m, 7.0 lb-ft)

**STARTER MOTOR**

- Install the starter motor (1).
- Install the water bypass hose (2).

 Starter motor bolt: 6 N·m (0.6 kgf-m, 4.5 lb-ft)



DRIVE TRAIN

CONTENTS

DRIVE TRAIN	4- 2
CONSTRUCTION	4- 2
REMOVAL AND DISASSEMBLY	4- 3
INSPECTION AND REPLACEMENT	4- 4
REASSEMBLY AND REMOUNTING	4- 7

DRIVE TRAIN CONSTRUCTION

10 N·m
(7.0 kgf·m, 7.0 lb-ft)

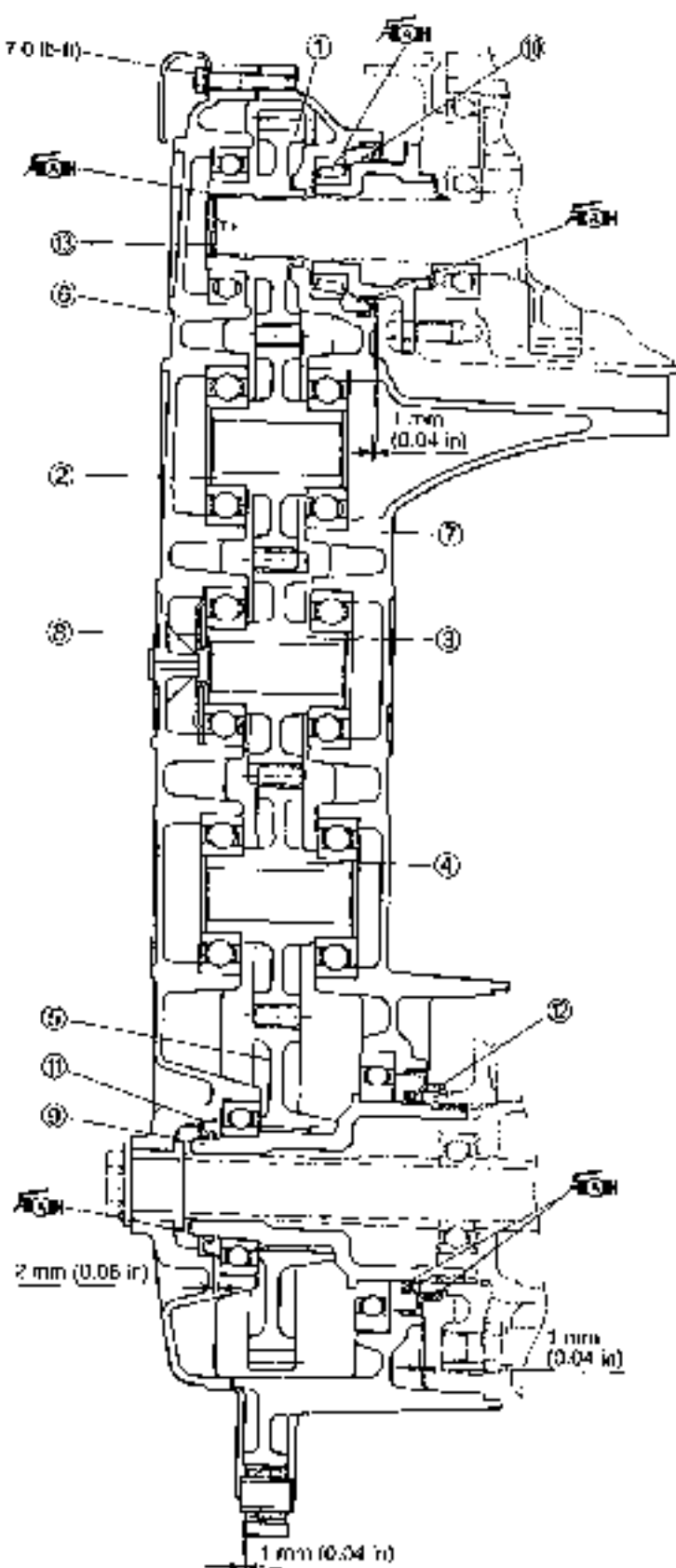

- ① Final drive gear
- ② No.1 gear
- ③ No.2 gear
- ④ No.3 gear
- ⑤ Final driver gear
- ⑥ Final gear case cover
- ⑦ Final gear case
- ⑧ Plate
- ⑨ Final driven gear hub
- ⑩ Right oil seal
- ⑪ Left oil seal
- ⑫ Oil seal
- ⊗ Circlip

REMOVAL AND DISASSEMBLY

- Remove the right/left side leg shield cover. (CAF 9-12)
- Drain the final gear oil. (CAF 2-15)
- Remove the rear wheel. (CAF 9-48)
- Remove the swingarm. (CAF 9-59)
- Remove the speedometer sensor (1) and harness guide (2).

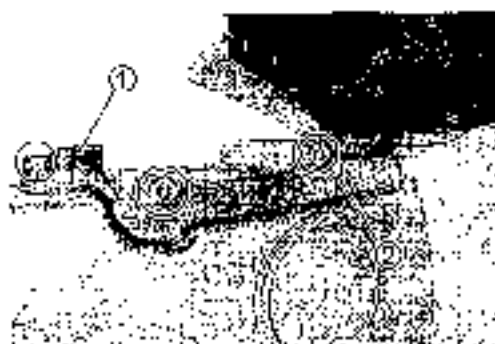

- Remove the final gear case.



- Remove the bearing from the engine



- Remove the dowel pins.

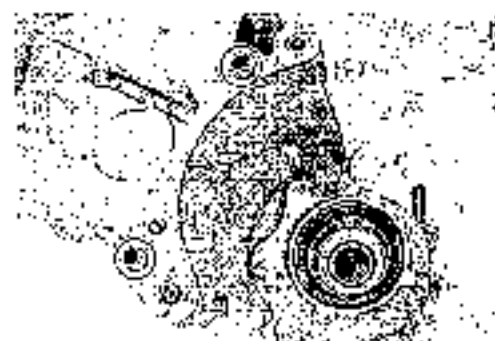

- Remove the final gear case bolts in a crisscross pattern.



- Remove the gasket (3) and dowel pins.
- Remove the following gears.

- (A) Final drive gear
- (B) No.1 gear
- (C) No.2 gear
- (D) No.3 gear
- (E) Final driven gear

- Remove the final drive gear hub (4).

INSPECTION AND REPLACEMENT GEARS

Inspect the gears for wear and damage.

If any defects are found, replace the gear with a new one.

OIL SEALS

Inspect the oil seals for wear and damage.

If any defects are found, replace the seal with a new one.

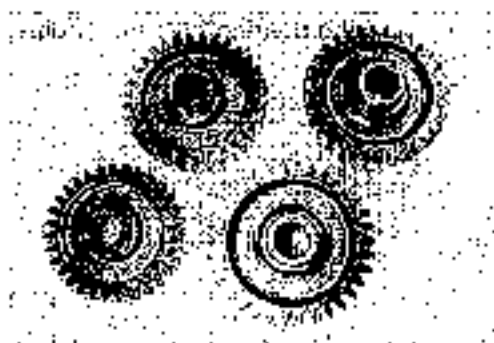
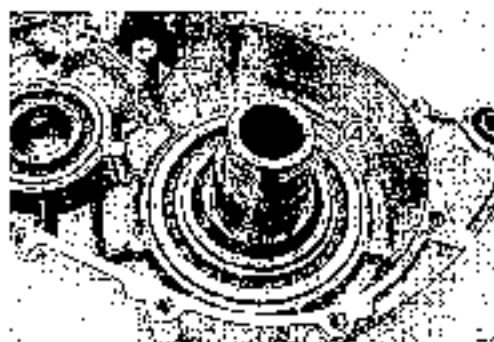
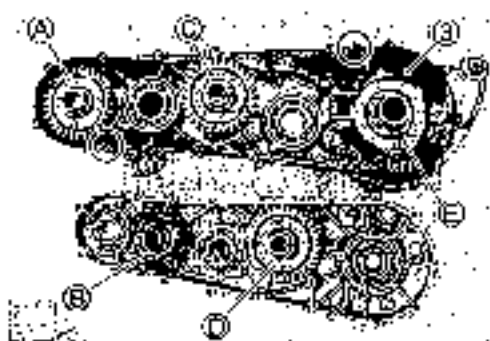

- Remove the oil seal with the special tool.

 08913-50121: Oil seal remover

CAUTION

Replace the removed oil seal with a new one.



- Install the new oil seal to the final gear case.
- Apply SUZUKI SUPER GREASE "A" to the oil seals.

 99000-25010: SUZUKI SUPER GREASE "A"

NOTE:

Direction of the oil seal is shown in the illustration at page 4-2.

BEARINGS

Inspect the inner race play of the bearing by hand while it is in the final gear case.

Rotate the inner race by hand to inspect for abnormal noise and smooth rotation.

If there is anything unusual, replace the bearing with a new one.

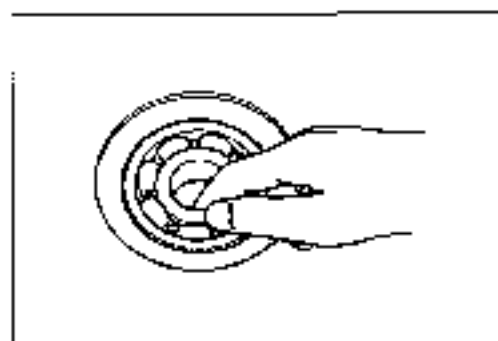

- Remove the bearing with the special tool.

 09921-20240: Bearing remover set

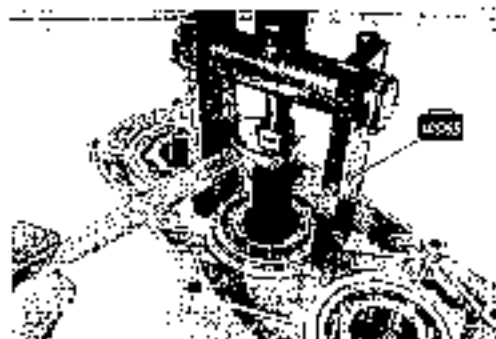

- To facilitate setting the special tool, knock down the plate ① that is at the No.2 gear bearing.
- Remove the bearing with the special tool.

 09921-20240: Bearing remover set

CAUTION

Replace the removed plate ① with a new one.



- Remove the final driven gear bearing by using the appropriate bar.

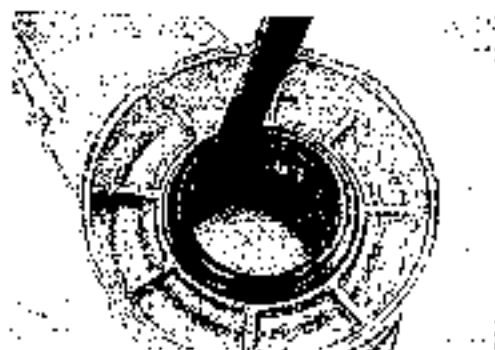

- Remove the final drive gear bearing with the special tools.

 09941-64511: Bearing remover
09930-30104: Sliding shaft



- Install the bearings to the final gear case with the special tool.

 09913-70210: Bearing installer set



CAUTION

Replace the removed bearing with a new one.



- Install the plate  into the final gear case cover at the No.2 gear, and then install the bearing

CAUTION

Install the plate  with the convexity  showed up.



FINAL DRIVEN GEAR HUB

Inspect the final driven gear hub for wear and damage. If any defects are found, replace the final driven gear hub with a new one.

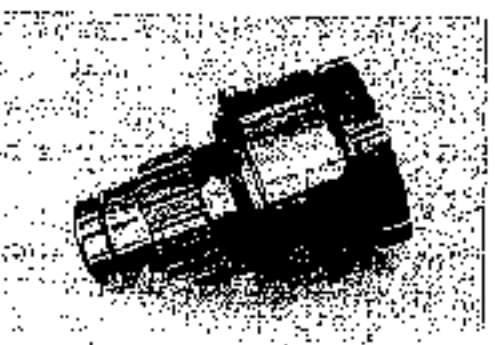

REASSEMBLY AND REMOUNTING

- Install the gears and final driven gear hub onto the final gear case cover.
- Install the dowel pin (1) and the new gasket.
- Apply SUZUKI SUPER GREASE "A" to spline of the final drive gear.

 99000-25010: SUZUKI SUPER GREASE "A"

- Assemble the final gear case.
- Tighten the final gear case bolts to the specified torque.

 Final gear case bolt: 10 N·m (1.0 kgf-m, 7.0 lb-ft)

- Apply SUZUKI SUPER GREASE "A" to the bearing
- Install the bearing to the drive shaft.

 99000-25010: SUZUKI SUPER GREASE "A"

- Install the final gear case assembly.
- Tighten the rear shock absorber mounting bolt.

 Rear shock absorber mounting bolt:
29 N·m (2.9 kgf-m, 21.0 lb-ft)

- Install the speedometer sensor (2) and harness guide (3).
- Tighten the speedometer sensor bolt to the specified torque.

 Speedometer sensor bolt: 10 N·m (1.0 kgf-m, 7.0 lb-ft)

NOTE:

Apply grease to the O-ring of speedometer sensor before installing the sensor to the final gear case.

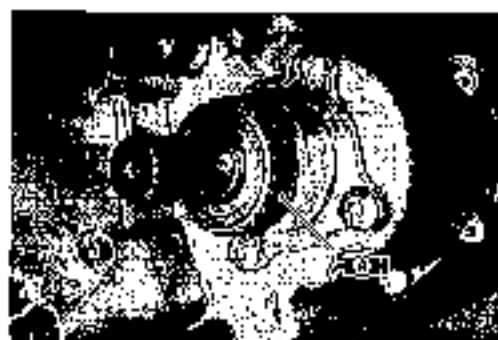
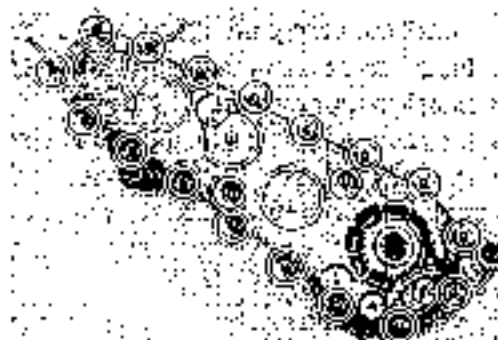
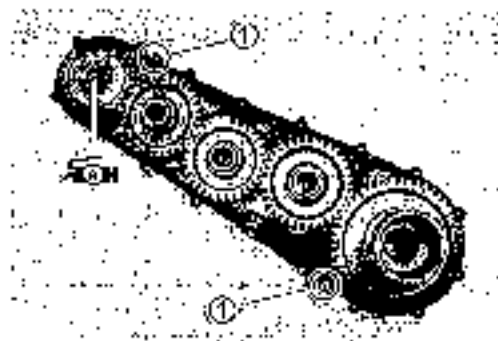

4-8 DRIVE TRAIN

- Clamp the breather hose (4) and speedometer sensor harness (5).



- Install the swingarm. (C7 9-61)
- Install the exhaust muffler. (C7 3-11)
- Install the rear wheel. (C7 9-56)
- Install the right/left side leg shield cover.
- Pour the final gear oil. (C7 2-16)

CVT

CONTENTS

CVT ASSEMBLY REMOVAL AND INSTALLATION	5- 2
CVT ASSEMBLY REMOVAL	5- 2
CVT ASSEMBLY INSTALLATION	5- 4
CVT DISASSEMBLY AND REASSEMBLY	5- 5
CVT DISASSEMBLY	5- 6
CVT INSPECTION	5-11
CVT PRIMARY PULLEY SHIMS ADJUSTMENT	5-16
CVT REASSEMBLY	5-19

CVT ASSEMBLY REMOVAL AND INSTALLATION

CVT ASSEMBLY REMOVAL

- Remove the engine assembly.

ENGINE REMOVAL  3-3



- Remove the bracket (1).

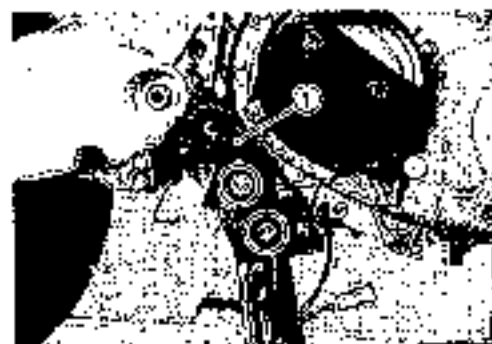

- Remove the bolt (2) and (3).

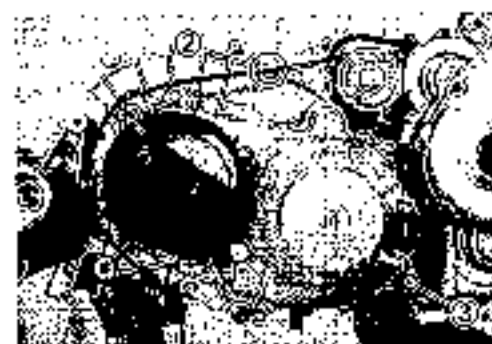

- Install the special tool as shown.

 09920-31050: CVT guide



- Remove the CVT mounting bolts.

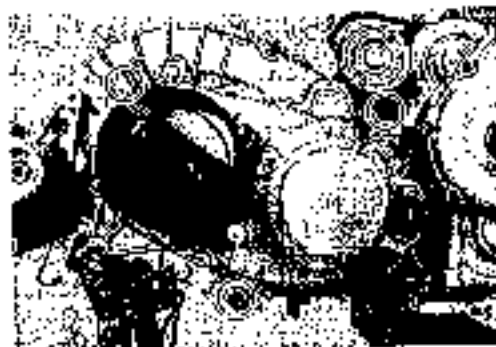

- Remove the CVT assembly.



CVT ASSEMBLY INSTALLATION

- Remove the valve timing inspection cap (1).

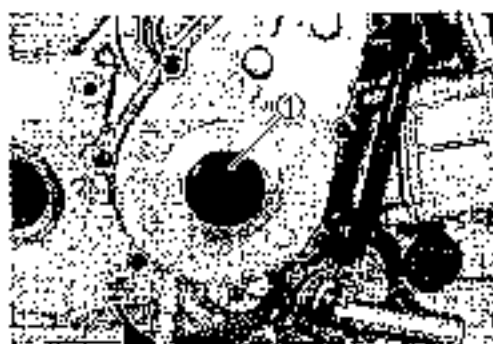

- Install the special tool to the engine assembly as shown.
- Apply SUZUKI MOLY PASTE to the primary driven gear shaft and clutch shaft.

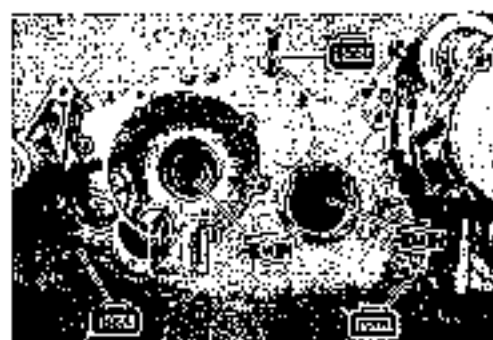

 09920-31050: CVT guide

 99000-25140: SUZUKI MOLY PASTE

- Engage the spline and install the CVT assembly by turning the crankshaft slowly.



- Install the bracket (2).
- Tighten the CVT mounting bolt to the specified torque.

 CVT mounting bolt: 50 N·m (5.0 kgf-m, 36.0 lb-ft)

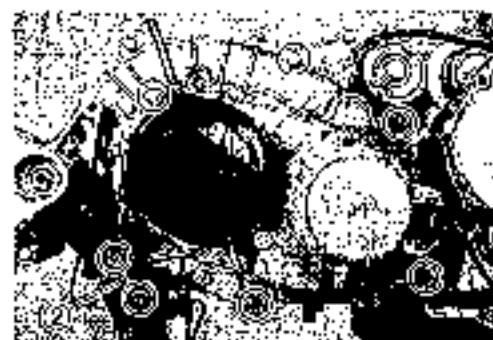

- Install the valve timing inspection cap (3).

ENGINE INSTALLATION  3-10

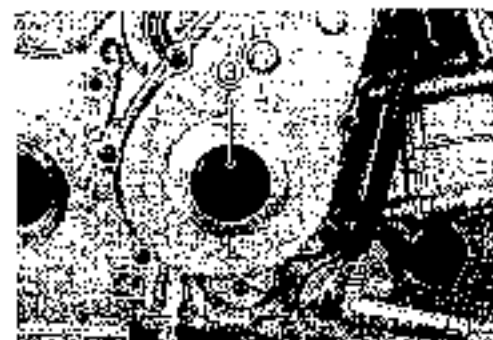

CVT DISASSEMBLY AND REASSEMBLY

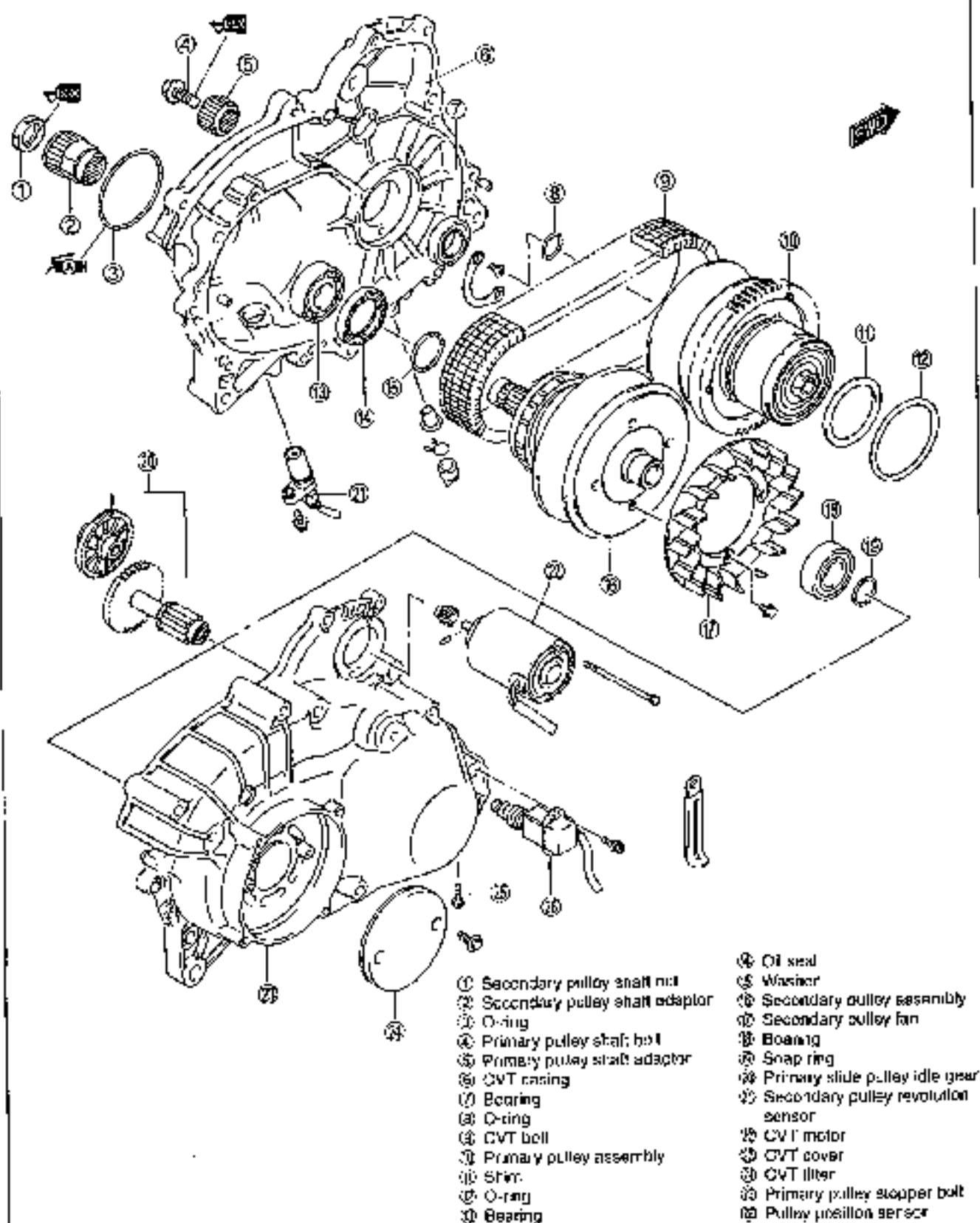

CVT DISASSEMBLY

CVT CASING/COVER

- Remove the pulley position sensor (1).
- Remove the secondary pulley revolution sensor (2).
- Remove the CVT motor.
- Remove the CVT filter cover.
- Remove the CVT filter.

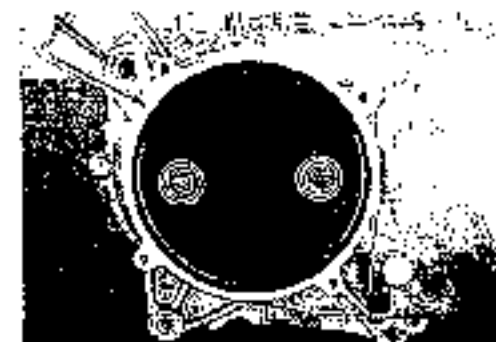
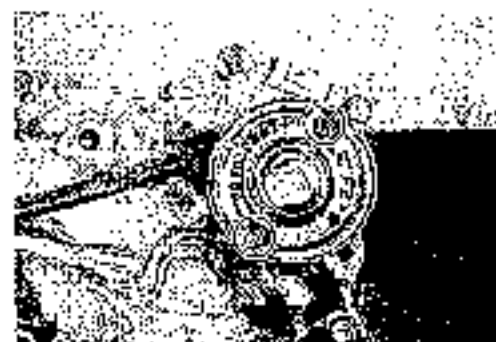

- Remove the secondary pulley shaft nut by holding the shaft with the special tools.

 09920-31020: Extension handle
09920-31030: CVT secondary pulley shaft holder



- Remove the secondary shaft adaptor with a bearing puller.



- Remove the primary pulley shell bolt by holding the primary pulley shaft with the special tools.

 09920-31010: CVT primary pulley shaft holder
09920-31020: Extension handle



- Screw in the special tool and remove the primary pulley shaft adaptor.

 09920-31040: CVT primary pulley shaft adaptor remover

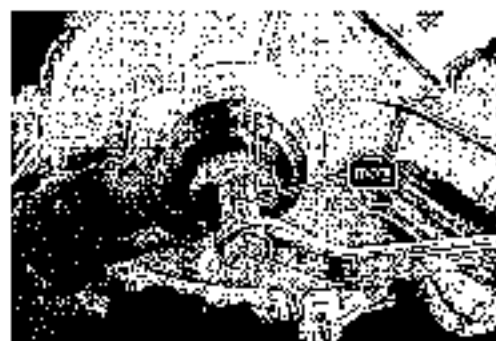

- Separate the CVT assembly by using 6 mm screws.

NOTE:

When separating the CVT assembly, position the right side facing downward.

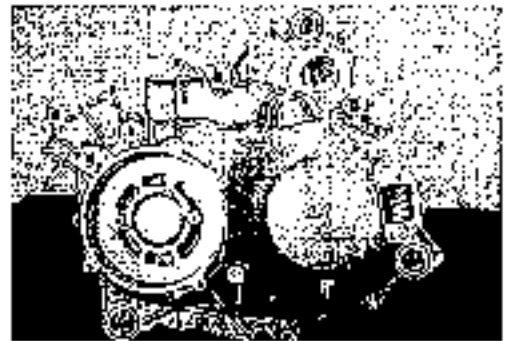

- After separating the CVT assembly, remove the CVT casing with the special tool.

 09920-13120: Crankcase separator

CAUTION

The crankcase separator plate is parallel with the end face of the CVT crankcase.

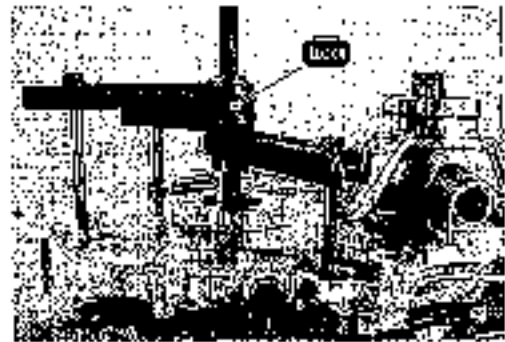

CAUTION

When servicing the inside of the CVT assembly, make sure to wear clean protective gloves.



- Remove the dowel pins.



SECONDARY PULLEY ASSEMBLY

- Remove the washer (1) on the secondary pulley shaft.

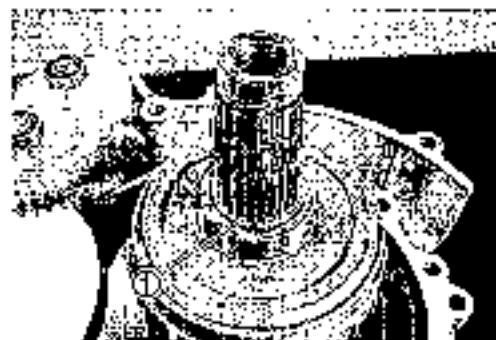

- Turn the primary slide pulley idle gear clockwise and open the primary pulley fully.



- Remove the primary slide pulley idle gear (2) and (3).



- Place a piece of clean rag on the primary pulley faces to prevent them from scratches.



- Remove the secondary pulley assembly.

CAUTION

Use caution not to cause scratches on the pulley surfaces due to their contact.



CVT BELT

- Place a piece of clean rag on the CVT cover mating face to prevent the CVT belt from scratches.

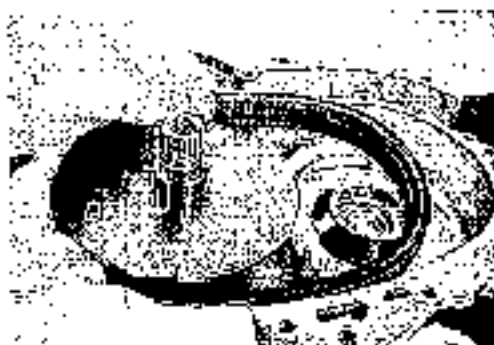

- Remove the CVT belt.



- Mark the direction mark on the CVT belt.



PRIMARY PULLEY

- Remove the primary pulley stopper bolt (A).

NOTE:

In the case of replacing the CVT belt only, removing of the primary pulley is not necessary. (CVT BELT INSTALLATION □ 5-20)

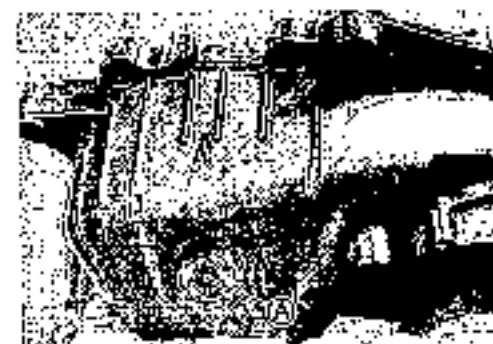

- Remove the primary pulley assembly.



- Remove the shim (1) and O-ring (2).



CVT INSPECTION

PRIMARY PULLEY INSPECTION

- Check that the primary pulley faces are free from any greasy substance.
- Inspect the primary pulley faces for any abnormal conditions such as scratches or stepped wear.

CAUTION

If the surface is found greasy, make sure to degrease it thoroughly.

- If any damages are found, replace the primary pulley assembly with a new one.
- Replace the O-ring with a new one.

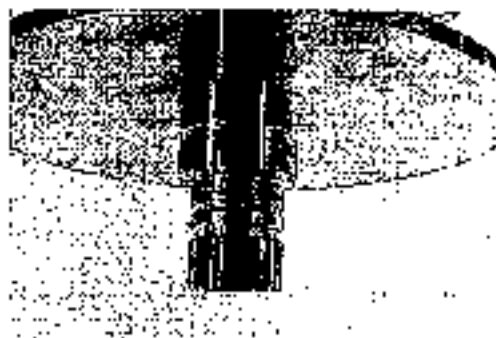

SECONDARY PULLEY INSPECTION

- Inspect the secondary pulley faces for any abnormal conditions such as scratches or stepped wear.
- If any damages are found, replace the primary pulley assembly with a new one.
- Check that the secondary pulley faces are free from any greasy substance.

CAUTION

If the surface is found greasy, make sure to degrease it thoroughly.



- Rotate the bearing outer race by finger to inspect for abnormal play, noise and smooth rotation.
- Inspect the secondary pulley fan for cracks or damage
- Replace the bearing or secondary pulley fan if there is anything unusual.

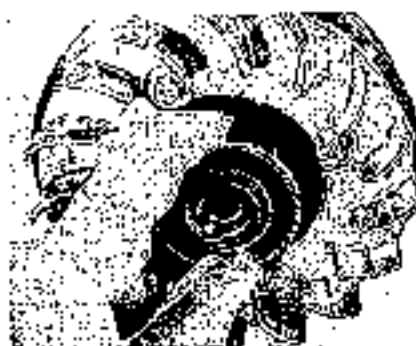

SECONDARY PULLEY DISASSEMBLY

- Remove the secondary pulley fan ①.

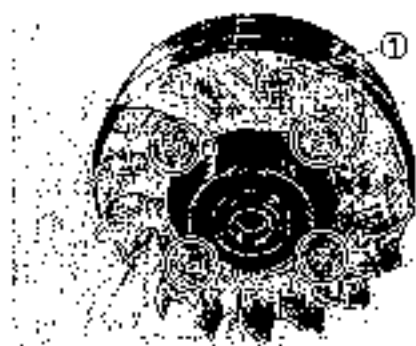

- Remove the snap ring ②.

 09900-06107: Snap ring pliers



- Remove the bearing with a bearing puller.

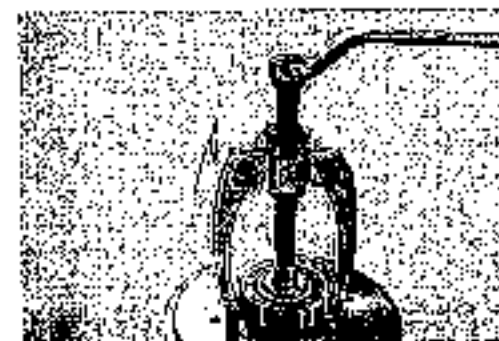

CVT MOTOR

- When replacing the CVT motor gear, align the hole ③ with the hole of motor shaft to install the pin.



SECONDARY PULLEY REASSEMBLY

- Fit the special tool and install a new bearing by a hydraulic press.

 09913-75810: Bearing Installer

CAUTION

Replace the removed bearing with a new one.

- Install the snap ring.

 09900-06107: Snap ring pliers

- Apply **THREAD LOCK "1342"** to the secondary pulley fan belts and tighten them.

 99000-32050: **THREAD LOCK "1342"**

CVT BELT INSPECTION

- Check that the drive belt is free from any greasy substance.
- Inspect the CVT belt for cracks or uneven wear.
- If any damages are found, replace the CVT belt with a new one.

CAUTION

- If the CVT belt is found greasy, replace it with a new one.
- Do not spray a cleaning solvent directly on the CVT belt.

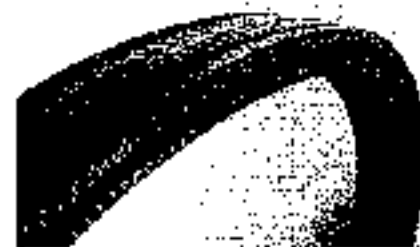
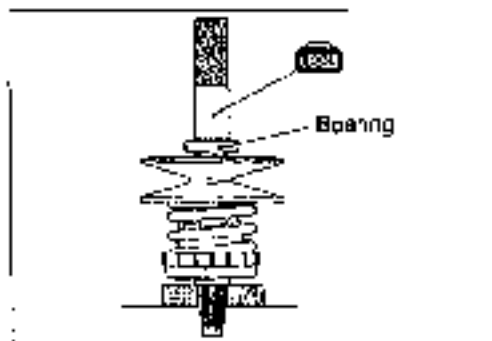

CVT CASING/COVER INSPECTION

- Replace the oil seal (1) with a new one.

CAUTION

Replace the oil seal every time the CVT assembly is separated.

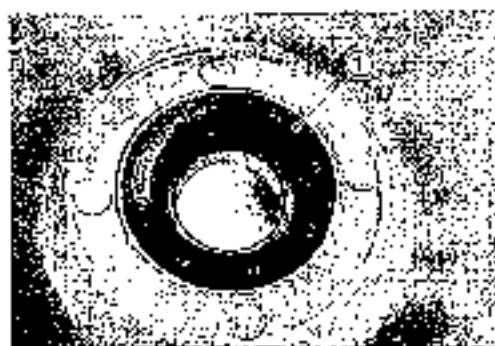

- Rotate the bearing by finger to inspect for abnormal play, noise and smooth rotation.
- Replace the bearing if there is anything unusual.



- Replace the O-ring with a new one.
- Apply SUZUKI SUPER GREASE "A" to the new O-ring and install it.

 99000-25030: SUZUKI SUPER GREASE "A" (USA)
99000-25010: SUZUKI SUPER GREASE "A" (Others)



- Thoroughly clean the case free from dirt and sealant.



CVT CASING/COVER DISASSEMBLY

- Remove the bearing retainer (4).

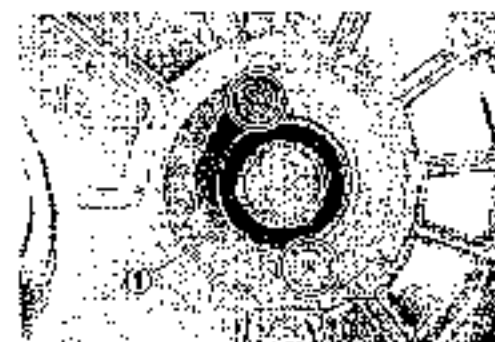

- Remove the bearing with the special tool.

 09921-20240: Bearing remover set



- Remove the bearing together with the oil seal by using the special tool.

 09913-70210: Bearing installer set

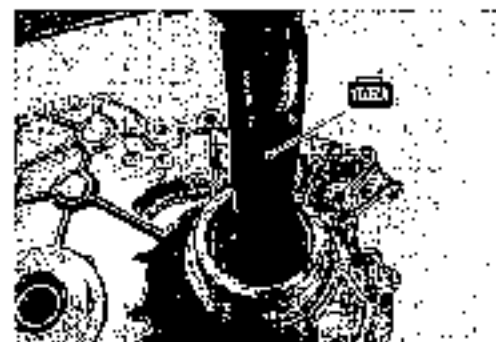

CVT CASING/COVER REASSEMBLY

- Install the bearing with the special tool.

 09913-70210: Bearing installer set

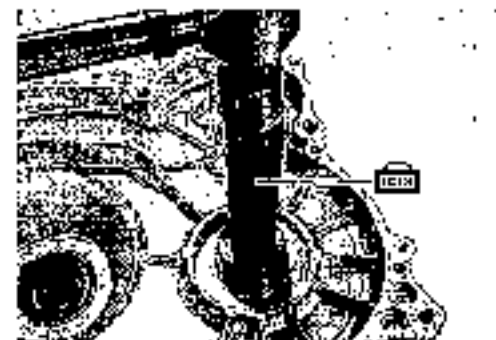

- Install the bearing retainer (1).

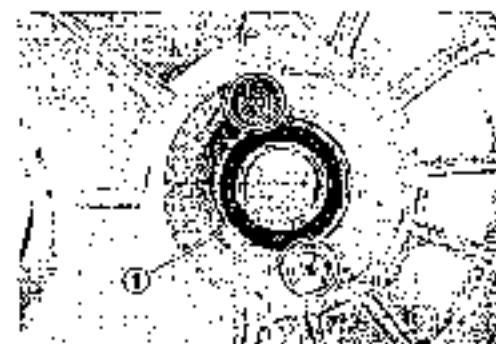

- Install the oil seal and bearing with the special tool.

 09913-70210: Bearing installer set

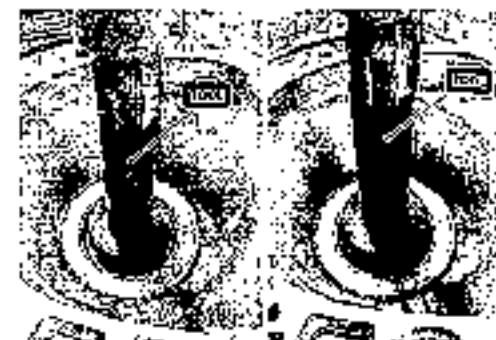

PRIMARY SLIDE PULLEY IDLE GEAR INSPECTION

- Inspect the pulley gears for wear or damage.
- Rotate the bearing by finger to inspect for abnormal play, noise and smooth rotation.
- If any wear or damage is found, replace the idle gear assembly with a new one.

**CVT PRIMARY PULLEY SHIMS ADJUSTMENT****CAUTION**

If any of the primary pulley, CVT casing or CVT cover has been replaced, install the shim whose thickness has been adjusted in the shim adjustment procedure.

CVT COVER DEPTH MEASUREMENT

- Fix the CVT cover securely with its mating face positioned horizontally.
- With the straightedge placed on the cover mating face, measure the depth D to the face (A) of the cover which the primary pulley assembly contacts using the vernier calipers.
- Measure the depth D at three points and note the measured value D₁, D₂ and D₃.

 09900-20102: Vernier calipers

**PRIMARY PULLEY HEIGHT MEASUREMENT**

- Install the primary pulley assembly onto the CVT casing.

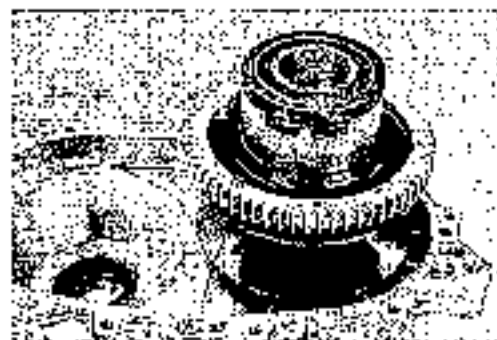

- Install the primary pulley shaft adaptor with the special tool.

 09913-60910: Bearing puller or
09913-61110: Bearing puller or
09913-61510: Bearing puller

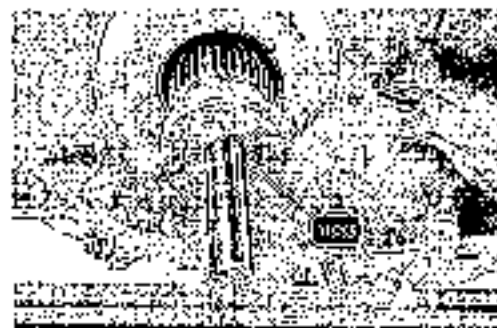

- Tighten the primary pulley shaft bolt to the specified torque with the special tools.

 Primary pulley shaft bolt: 84 N·m (6.4 kgf-m, 46.5 lb-ft)

 09920-31010: CVT primary pulley shaft holder
09920-31020: Extension handle



- Fix the CVT casing securely with its mating face positioned horizontally.
- With the straightedge placed on the casing mating face, measure the height H to the face (A) of the primary pulley assembly using the vernier calipers.
- Measure the height H at three points and note the measured value H₁, H₂ and H₃.

 09900-20102: Vernier calipers

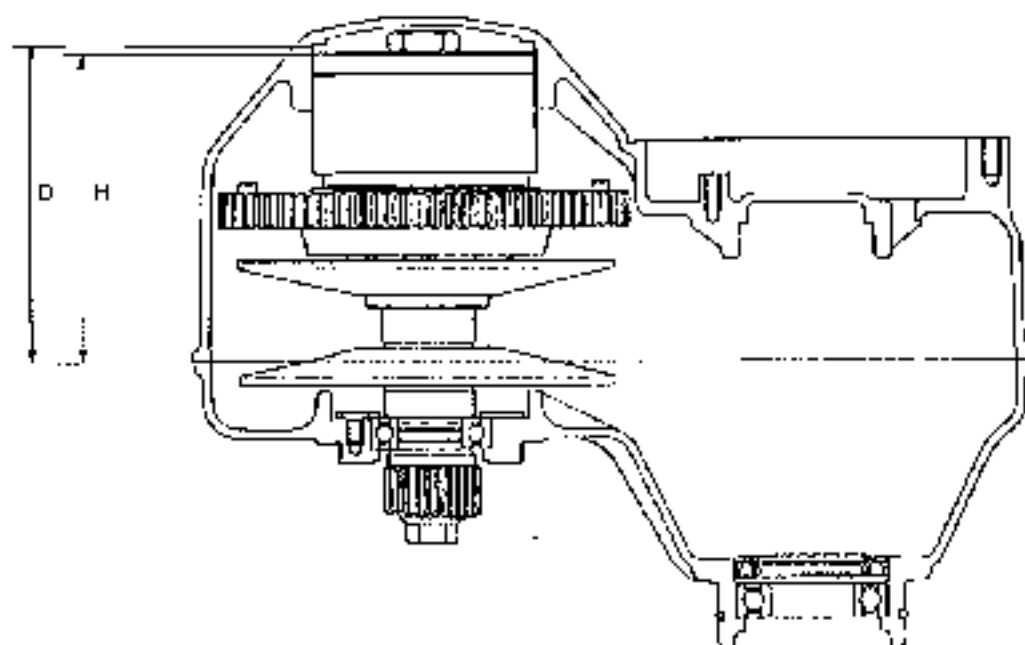
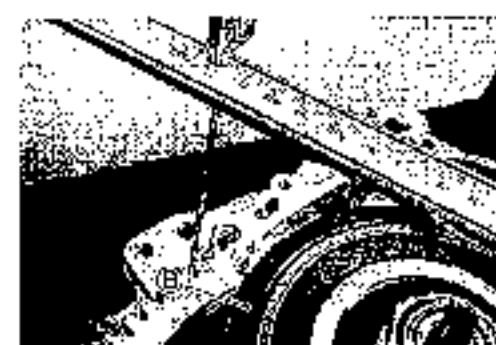
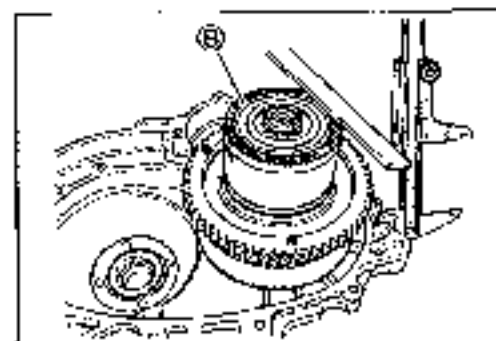

SHIM SELECTION

- Get the average depth D_a by averaging D_1 , D_2 and D_3 .
- Get the average height H_a by averaging H_1 , H_2 and H_3 .
- Obtain the valve X by subtracting D_a from H_a .
- Using the chart below, select the appropriate shim with reference to the value X.

SHIM SELECTION TABLE

SHIM THICKNESS	VALUE X
0.12 mm (0.005 in)	3.12 – 3.31 mm (0.123 – 0.130 in)
0.32 mm (0.013 in)	3.32 – 3.51 mm (0.131 – 0.138 in)
0.52 mm (0.020 in)	3.52 – 3.71 mm (0.139 – 0.146 in)
0.72 mm (0.028 in)	3.72 – 3.91 mm (0.147 – 0.154 in)
0.92 mm (0.036 in)	3.92 – 4.11 mm (0.155 – 0.162 in)
1.12 mm (0.044 in)	4.12 – 4.31 mm (0.163 – 0.170 in)
1.32 mm (0.052 in)	4.32 – 4.51 mm (0.171 – 0.178 in)

NOTE:

The shims are available as a set (21746-10G00).

EXAMPLE:

CVT cover depth D	$D_1 = 125.35 \text{ mm (4.935 in)}$
	$D_2 = 125.15 \text{ mm (4.927 in)}$
	$D_3 = 125.25 \text{ mm (4.931 in)}$
Average depth	$D_a = (125.35 + 125.15 + 125.25) \div 3$ $= 125.25 \text{ mm (4.931 in)}$
Primary pulley height H	$H_1 = 121.45 \text{ mm (4.781 in)}$
	$H_2 = 121.60 \text{ mm (4.787 in)}$
	$H_3 = 121.45 \text{ mm (4.781 in)}$
Average height	$H_a = (121.45 + 121.60 + 121.45) \div 3$ $= 121.50 \text{ mm (4.783 in)}$
Value X	$= D_a - H_a$ $= 125.25 \text{ mm (4.931 in)} - 121.50 \text{ mm (4.783 in)}$ $= 3.75 \text{ mm (0.148 in)}$

* Select the 0.72 mm (0.028 in) shim

CVT REASSEMBLY

PRIMARY PULLEY ASSEMBLY

CAUTION

Wear clean protective gloves.

- Degrease the inside of the CVT cover and CVT casing completely with a cleaning solvent by using a clean rag.

- Install the O-ring (1) and shim (2).

CAUTION

If any of the primary pulley, CVT casing or CVT cover has been replaced, install the shim whose thickness has been adjusted in the shim adjustment procedure.

- Turn the slide pulley gear and close the primary pulley.

- Align the cutaway (A) of the screw shaft with the protrusion (B).

CAUTION

Degrease the primary pulley faces completely.

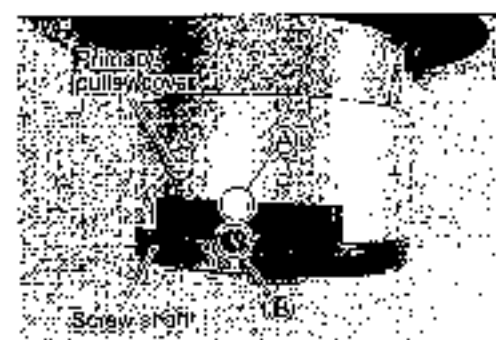
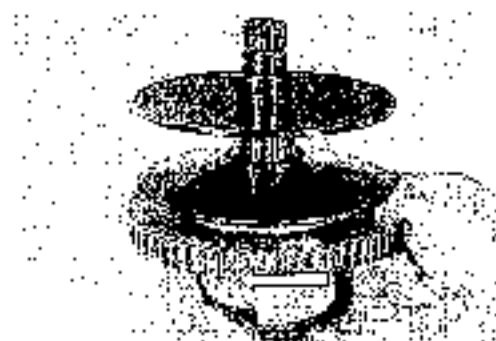
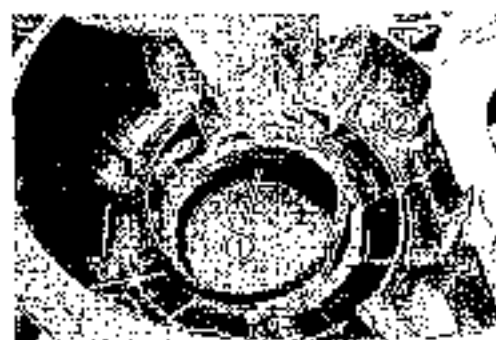

NOTE:

Primary pulley cover has the protrusion (A) and (C).

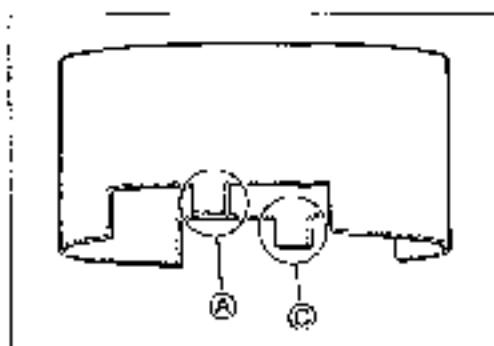

- Turn the primary pulley cover 180 degrees along the groove on the screw shaft and align the cutaway (D) with (E) or (F) position of the primary pulley cover.

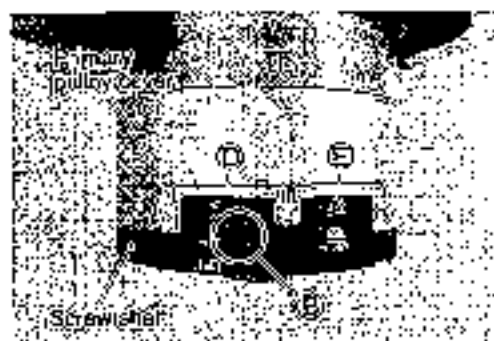

- With the cutaway (E) aligned with the stopper bolt hole (G) of the CVT cover, position the primary pulley assembly onto the CVT cover.



- Make sure that the screw shaft is in proper position by checking the location of cutaway (E) when viewed from the stopper bolt hole (F).
- Tighten the stopper bolt to the specified torque.

[T] Primary pulley stopper bolt: 36 N·m (3.6 kgf·m, 26.0 lb-ft)

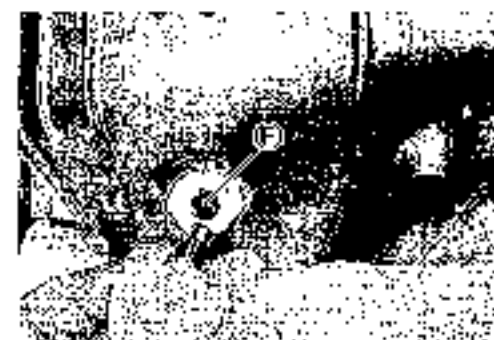
**CVT BELT INSTALLATION**

- Install the primary slide pulley idle gear temporarily.
- Turn the idle gear clockwise and open the primary pulley fully.



- Place a piece of clean rag on the CVT casing mating face to prevent the CVT belt from scratches.



- Install the CVT belt so that the direction mark on the CVT belt points in the normal turning direction.

CAUTION

Never touch the side walls of the CVT belt.

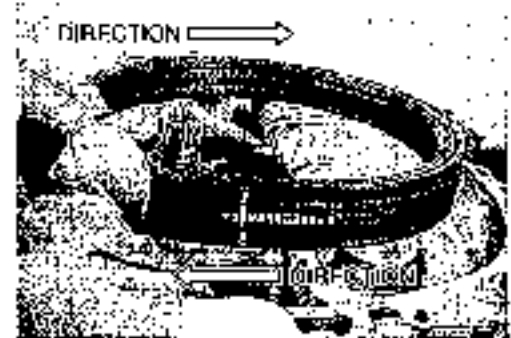

- Place a piece of clean rag on the primary pulley faces to prevent them from scratches.



SECONDARY PULLEY ASSEMBLY

- Install the secondary pulley assembly.
- Remove the rags.

CAUTION

- Degrease the secondary pulley faces completely.
- Use caution not to cause scratches on the pulley surfaces due to their contact.



- Check that the secondary pulley is located inwardly relative to the primary pulley.



- Check that the CVT bolt is in parallel with the CVT cover mating face.



- Install the primary slide pulley (1) and (2).



- Turn the idle gear until the primary pulley faces just touch the CVT bolt.

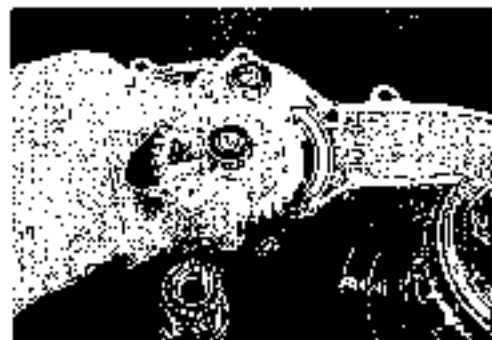

- Check the CVT belt movement for smooth rotation by turning the both pulleys.



- Install the secondary pulley washer (3).



CVT CASING/COVER

- Wipe the CVT casing/cover mating surface with a cleaning solvent.
- Fit the dowel pins.

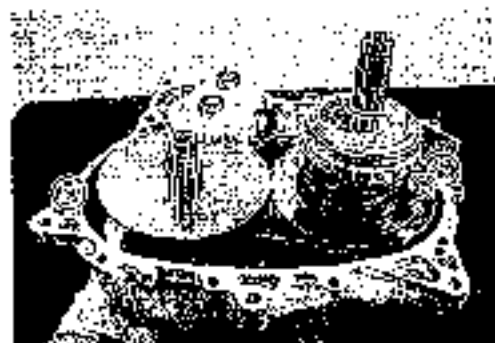

- Apply a small quantity of SUZUKI SUPER GREASE to the grease groove (A) of the primary pulley shaft.

99000-26090: SUZUKI SUPER GREASE "A" (USA)
99000-25010: SUZUKI SUPER GREASE "A" (Others)

CAUTION

Do not apply grease under the groove (A).

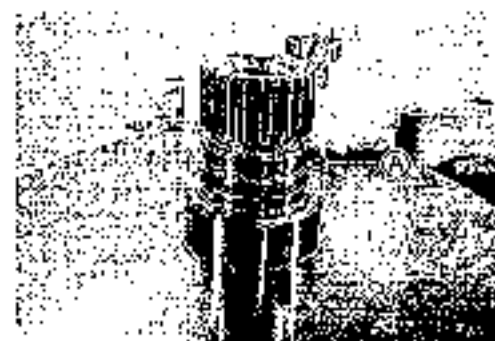

- Cover the secondary pulley shaft with a vinyl film to prevent oil seal damage.

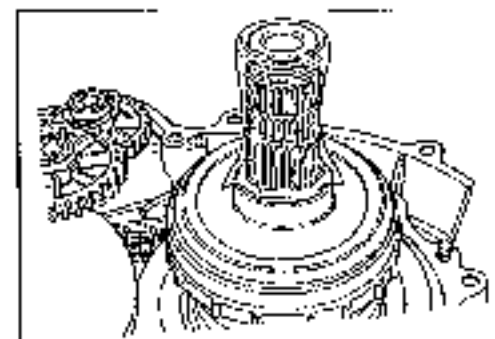

- Apply a small quantity of engine oil to the main lip (B) of the oil seal.

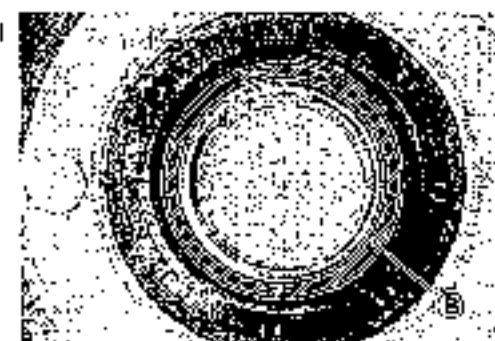
ENGINE OIL

- Apply SUZUKI BOND "1215" to the mating surface of the CVT casing.

99000-31110: SUZUKI BOND "1215"

NOTE:

- * Make surfaces free from moisture, oil, dust and other foreign materials.
- * Spread on surfaces thinly to form an even layer, and assemble the CVT casing and cover within few minutes.

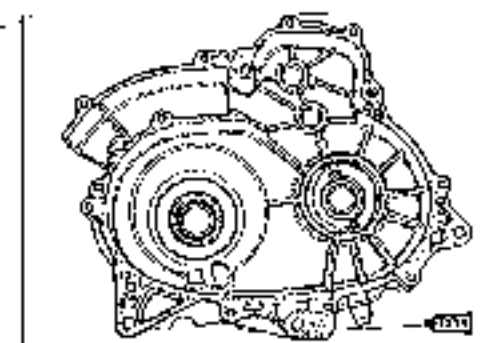

- Tighten the CVT cover bolts diagonally to the specified torque.

 CVT cover bolt: 22 N·m (2.2 kgf-m, 16.0 lb-ft)

NOTE:

Fit the clamp to the bolt 

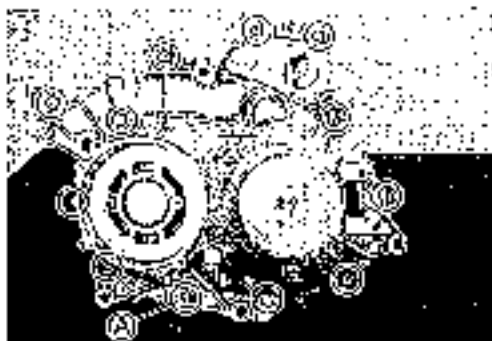

- Apply SUZUKI SUPER GREASE "A" to the primary pulley shaft adaptor.

 99000-25030: SUZUKI SUPER GREASE "A" (USA)
99000-25010: SUZUKI SUPER GREASE "A" (Others)



- Install the primary pulley shaft adaptor with the special tool.

 09913-60910: Bearing puller or
09913-61110: Bearing puller or
09913-61510: Bearing puller



- Apply THREAD LOCK SUPER "1360" to the primary pulley shaft bolt.

 99000-32130: THREAD LOCK SUPER "1360"



- Tighten the primary pulley shaft bolt to the specified torque with the special tools.

 Primary pulley shaft bolt: 64 N·m (6.4 kgf-m, 46.5 lb-ft)

 09920-31010: CVT primary pulley shaft holder
09920-31020: Extension handle



- Apply a small quantity of engine oil to the secondary pulley bearing.
- Apply grease to the secondary pulley shaft adaptor.

ENGINE OIL

-  99000-25030: SUZUKI SUPER GREASE "A" (USA)
- 99000-25010: SUZUKI SUPER GREASE "A" (Others)



- Install the special tool onto the secondary pulley shaft.

09910-32850: Crankshaft installer attachment

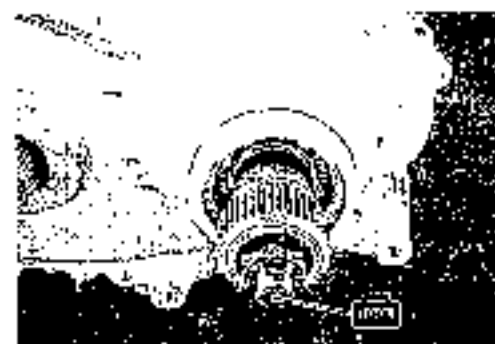

- Press in the secondary pulley shaft adaptor with the special tool.

09910-32812: Crankshaft installer



- Apply THREAD LOCK SUPER "1360" to the secondary pulley shaft nut.

99000-32130: THREAD LOCK SUPER "1360"



- Tighten the secondary pulley shaft nut to the specified torque with the special tools.

Secondary pulley shaft nut:

226 N·m (22.6 kgf·m, 163.5 lb-ft)

-  09920-31020: Extension handle
- 09920-31030: CVT secondary pulley shaft holder

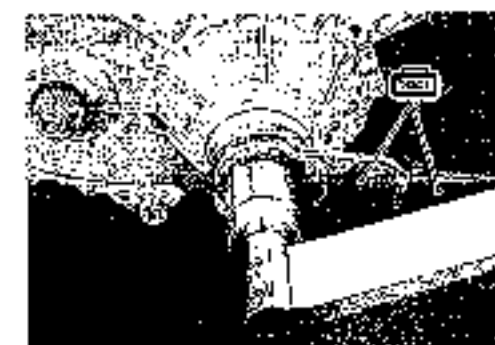

- Clean the CVT filter by using compressed air.



- Install the CVT filter.

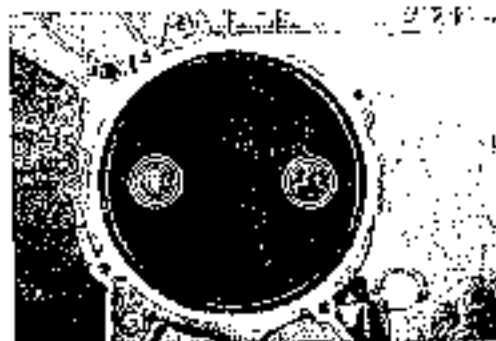

- Install the CVT filter cover.
- Fit the clamp to the bolts ⑤.

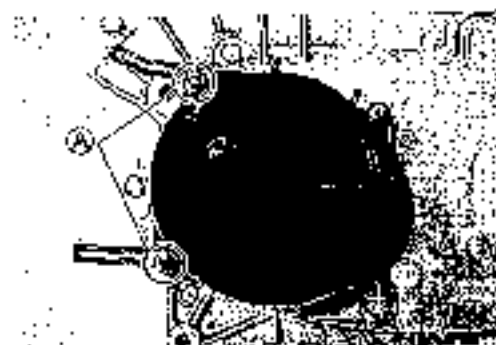

- Install the CVT motor.

NOTE:

Pay attention to the direction of the CVT motor.

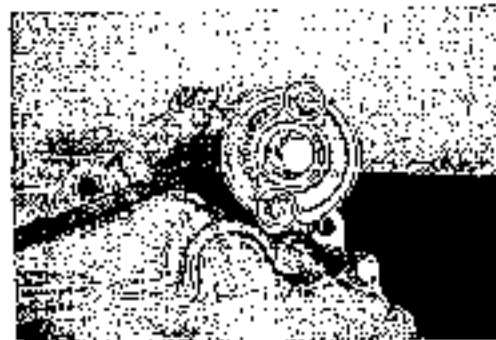

- Install the secondary pulley revolution sensor.



- Install the pulley position sensor with the sensor pushed toward the primary pulley shaft side.



CVT BELT BRAKE-IN PROCEDURES

- It is necessary to allow the CVT belt to "BRAKE-IN" before subjecting the CVT to maximum stresses.

Brake -in engine speed

Initial 800 km (500 miles): Below 4 000 rpm.

NOTE:

When the CVT belt is new, the engine rpm may jump briefly under hard acceleration due to the smoothness of the belt.

CLAMP LOCATION

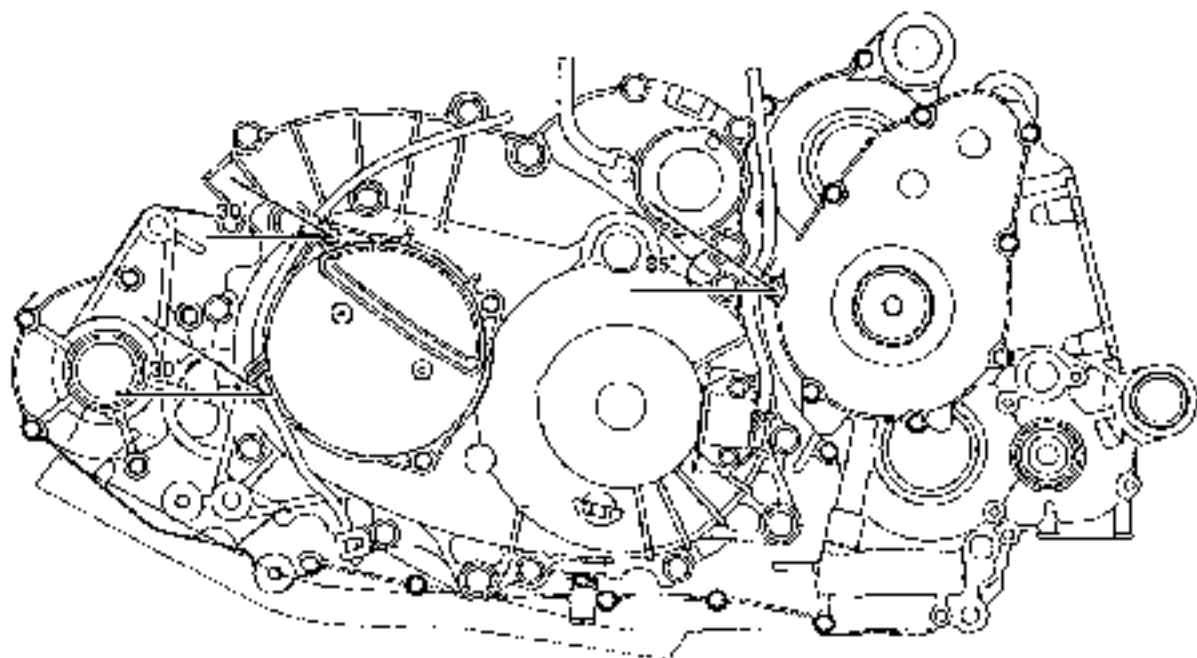

FI SYSTEM/ CVT SYSTEM

CONTENTS

PRECAUTIONS IN SERVICING	6- 2
ELECTRICAL PARTS	6- 2
ELECTRICAL CIRCUIT INSPECTION PROCEDURE	6- 5
USING TESTERS	6- 8
FI SYSTEM TECHNICAL FEATURES	6- 9
INJECTION TIME (INJECTION VOLUME)	6- 9
COMPENSATION OF INJECTION TIME (VOLUME)	6-10
INJECTION STOP CONTROL	6-10
FI SYSTEM PARTS LOCATION	6-11
FI SYSTEM WIRING DIAGRAM	6-13
CVT SYSTEM TECHNICAL FEATURES	6-14
CVT SYSTEM PARTS LOCATION	6-15
SELF-DIAGNOSIS FUNCTION	6-18
USER MODE	6-18
DEALER MODE	6-19
TPS ADJUSTMENT	6-20
FAIL-SAFE FUNCTION	6-21
FI SYSTEM/ CVT SYSTEM TROUBLESHOOTING	6-22
CUSTOMER COMPLAINT ANALYSIS	6-22
SELF-DIAGNOSTIC PROCEDURES	6-24
SELF-DIAGNOSIS RESET PROCEDURE	6-24
MALFUNCTION CODE AND DEFECTIVE CONDITION	6-25
"C11" CMP SENSOR CIRCUIT MALFUNCTION	6-27
"C12" CKP SENSOR CIRCUIT MALFUNCTION	6-28
"C13" IAP SENSOR CIRCUIT MALFUNCTION	6-29
"C14" TP SENSOR CIRCUIT MALFUNCTION	6-31
"C15" ECT SENSOR CIRCUIT MALFUNCTION	6-33
"C16" SPEED SENSOR CIRCUIT MALFUNCTION	6-34
"C21" IAT SENSOR CIRCUIT MALFUNCTION	6-36
"C22" AP SENSOR CIRCUIT MALFUNCTION	6-37
"C23" TO SENSOR CIRCUIT MALFUNCTION	6-39
"C24" or "C25" IGNITION SYSTEM MALFUNCTION	6-40
"C32" or "C33" FUEL INJECTOR CIRCUIT MALFUNCTION	6-40
"C40" IAC VALVE CIRCUIT MALFUNCTION	6-41
"C41" FP RELAY CIRCUIT MALFUNCTION	6-41
"C42" IG SWITCH CIRCUIT MALFUNCTION	6-41
"C44" HO2 SENSOR (HO2S) CIRCUIT MALFUNCTION (E-02, 19)	6-42
"C50" CVT SERIAL COMMUNICATION CIRCUIT MALFUNCTION	6-44
"C51" CVT MOTOR CIRCUIT MALFUNCTION	6-45
"C52" CVT PULLEY POSITION SENSOR (PPS) CIRCUIT MALFUNCTION	6-47
"C53" CVT SPEED SENSOR CIRCUIT MALFUNCTION	6-49
"C54" CVT SECONDARY PULLEY REVOLUTION SENSOR CIRCUIT MALFUNCTION	6-51
"C55" CVT ENGINE REVOLUTION SIGNAL CIRCUIT MALFUNCTION	6-53
"C56" CVT THROTTLE POSITION SIGNAL CIRCUIT MALFUNCTION	6-54
"C58" CVT REDUCTION RATIO DISAGREEMENT	6-55
SENSORS	6-56

PRECAUTIONS IN SERVICING

When handling the FI/CVT component parts or servicing the FI system/CVT system, observe the following points for the safety of the system.

ELECTRICAL PARTS

CONNECTOR/COUPLER

- When connecting a connector, be sure to push it in until a click is felt.
- With a lock type coupler, be sure to release the lock when disconnecting, and push it in fully till the lock works when connecting it.
- When disconnecting the coupler, be sure to hold the coupler body and do not pull the lead wires.
- Inspect each terminal on the connector/coupler for looseness or bonding.
- Inspect each terminal for corrosion and contamination. The terminals must be clean and free of any foreign material which could impede proper terminal contact.

- Inspect each lead wire circuit for poor connection by shaking it by hand lightly. If any abnormal condition is found, repair or replace.

- When taking measurements at electrical connectors using a tester probe, be sure to insert the probe from the wire harness side (backside) of the connector/coupler.

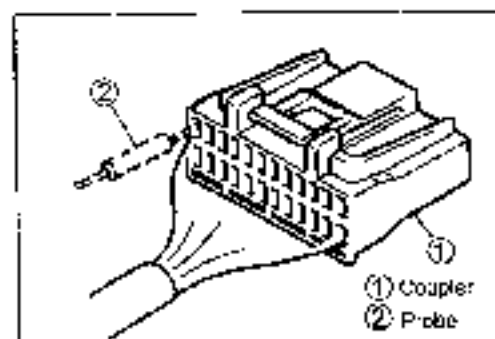
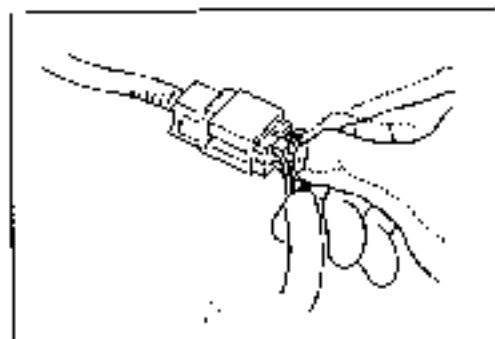
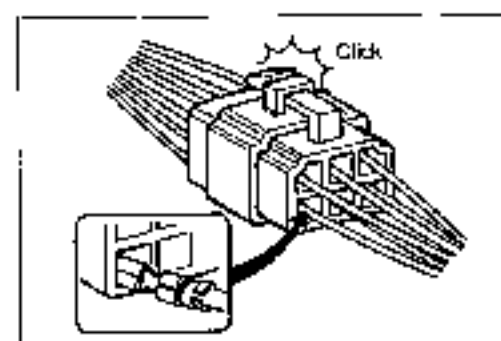
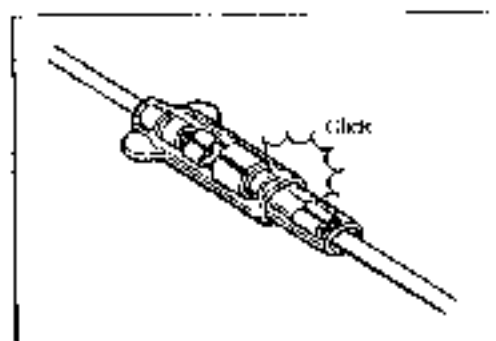

- When connecting meter probe from the terminal side of the coupler (connection from harness side not being possible), use extra care not to force and cause the male terminal to bend or the female terminal to open.

Connect the probe as shown to avoid opening of female terminal.

Never push in the probe where male terminal is supposed to fit.

- Check the male connector for bend and female connector for excessive opening. Also check the coupler for locking (looseness), corrosion, dust, etc.

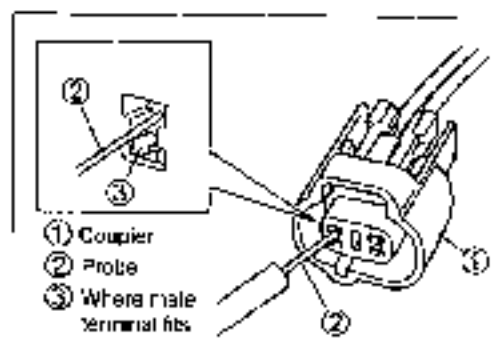

FUSE

- When a fuse blows, always investigate the cause, correct it and then replace the fuse.
- Do not use a fuse of a different capacity.
- Do not use wire or any other substitute for the fuse.

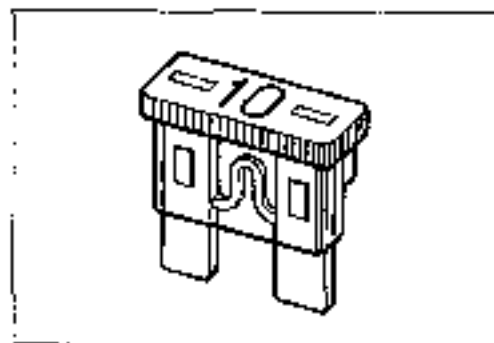

ECM/CVT CONTROL UNIT/VARIOUS SENSORS

- Since each component is a high-precision part, great care should be taken not to apply any sharp impacts during removal and installation.

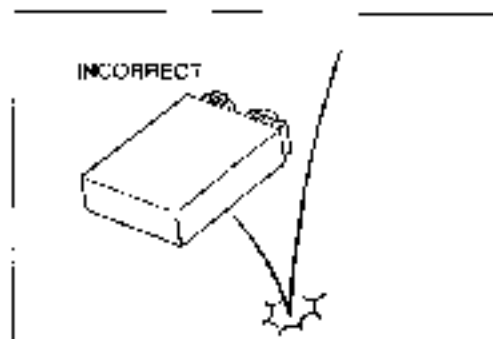

- Be careful not to touch the electrical terminals of the ECM/CVT control unit. The static electricity from your body may damage this part.

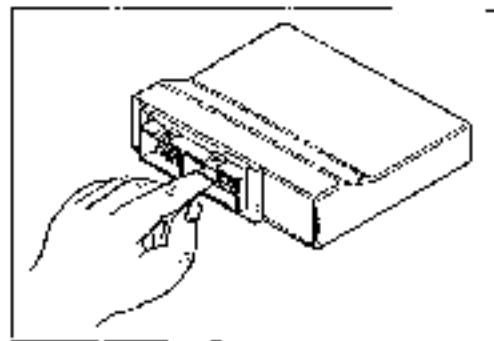

- When disconnecting and connecting the ECM/CVT control unit couplers, make sure to turn OFF the ignition switch, or electronic parts may get damaged.

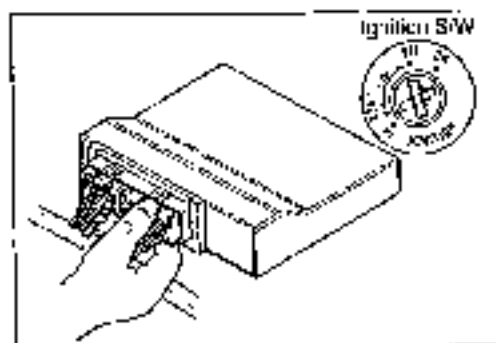

- Battery connection in reverse polarity is strictly prohibited. Such a wrong connection will damage the components of the FI system/CVT control unit instantly when reverse power is applied.

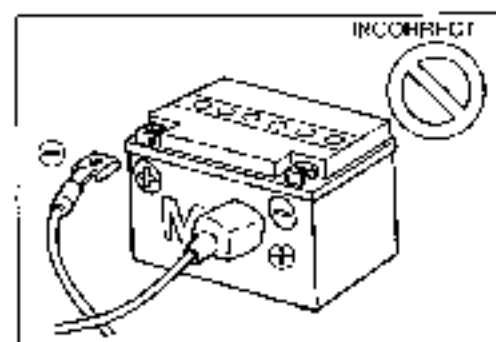

- Removing any battery terminal of a running engine is strictly prohibited. The moment such removal is made, damaging counter electromotive force will be applied to the ECM/CVT control unit which may result in serious damage.

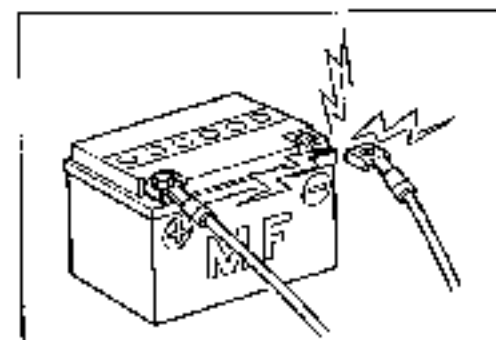

- Before measuring voltage at each terminal, check to make sure that battery voltage is 11 V or higher. Terminal voltage check at low battery voltage will lead to erroneous diagnosis.

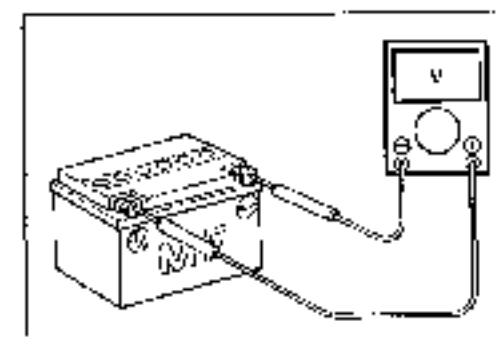

- Never connect any tester (voltmeter, ohmmeter, or whatever) to the ECM/CVT control unit when its coupler is disconnected. Otherwise, damage to ECM/CVT control unit may result.
- Never connect an ohmmeter to the ECM/CVT control unit with its coupler connected. If attempted, damage to ECM/CVT control unit or sensors may result.
- Be sure to use a specified voltmeter/ohmmeter. Otherwise, accurate measurements may not be obtained and personal injury may result.

ELECTRICAL CIRCUIT INSPECTION PROCEDURE

While there are various methods for electrical circuit inspection, described here is a general method to check for open and short circuit using an ohmmeter and a voltmeter.

OPEN CIRCUIT CHECK

Possible causes for the open circuit are as follows. As the cause can exist in the connector/coupler or terminal, they need to be checked carefully.

- Loose connection of connector/coupler
- Poor contact of terminal (due to dirt, corrosion or rust, poor contact tension, entry of foreign object etc.)
- Wire harness being open
- Poor terminal-to-wire connection
- Disconnect the negative cable from the battery.
- Check each connector/coupler at both ends of the circuit being checked for loose connection. Also check for condition of the coupler lock if equipped.

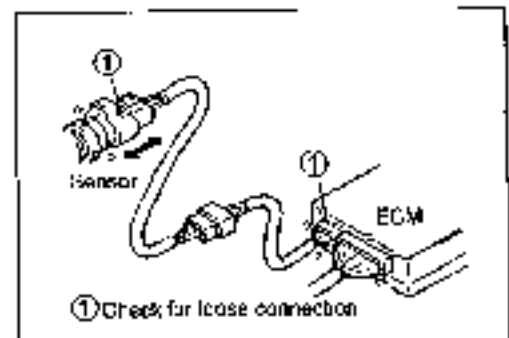

- Using a test male terminal, check the female terminals of the circuit being checked for contact tension. Check each terminal visually for poor contact (possibly caused by dirt, corrosion, rust, entry of foreign object, etc.). At the same time, check to make sure that each terminal is fully inserted in the coupler and locked. If contact tension is not enough, rectify the contact to increase tension or replace. The terminals must be clean and free of any foreign material which could impede proper terminal contact.

Check contact tension by inserting and removing.



- Using continuity inspect or voltage check procedure as described below, inspect the wire harness terminals for open circuit and poor connection. Locate abnormality, if any.

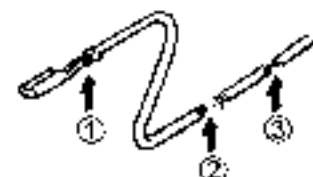

- ① Looseness of crimping
- ② Open
- ③ Thin wire (a few strands left)

Continuity check

- Measure resistance across coupler (B) (between (A) and (C) in the figure).

If no continuity is indicated (infinity or over limit), the circuit is open between terminals (A) and (C).

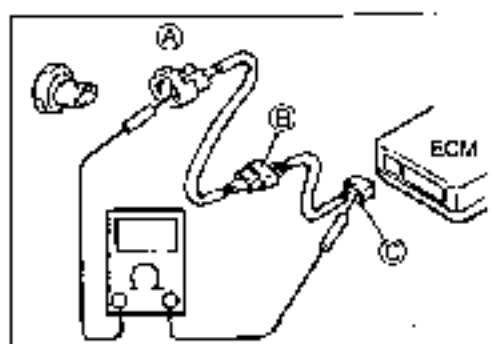

- Disconnect the coupler (B) and measure resistance between couplers (A) and (B).

If no continuity is indicated, the circuit is open between couplers (A) and (B). If continuity is indicated, there is an open circuit between couplers (B) and (C) or an abnormality in coupler (B) or coupler (C).

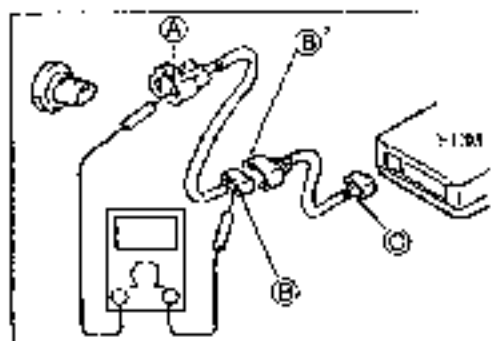
**VOLTAGE CHECK**

If voltage is supplied to the circuit being checked, voltage check can be used as circuit check.

- With all connectors/couplers connected and voltage applied to the circuit being checked, measure voltage between each terminal and body ground.

If measurements were taken as shown in the figure at the right and results are as listed below, it means that the circuit is open between terminals (A) and (B).

Voltage Between:

- (C) and body ground: Approx. 5 V
- (B) and body ground: Approx. 5 V
- (A) and body ground: 0 V

Also, if measured values are as listed below, a resistance (abnormality) exists which causes the voltage drop in the circuit between terminals (A) and (B).

Voltage Between:

- (C) and body ground: Approx. 5 V
- (B) and body ground: Approx. 5 V — 2 V voltage drop
- (A) and body ground: 3 V

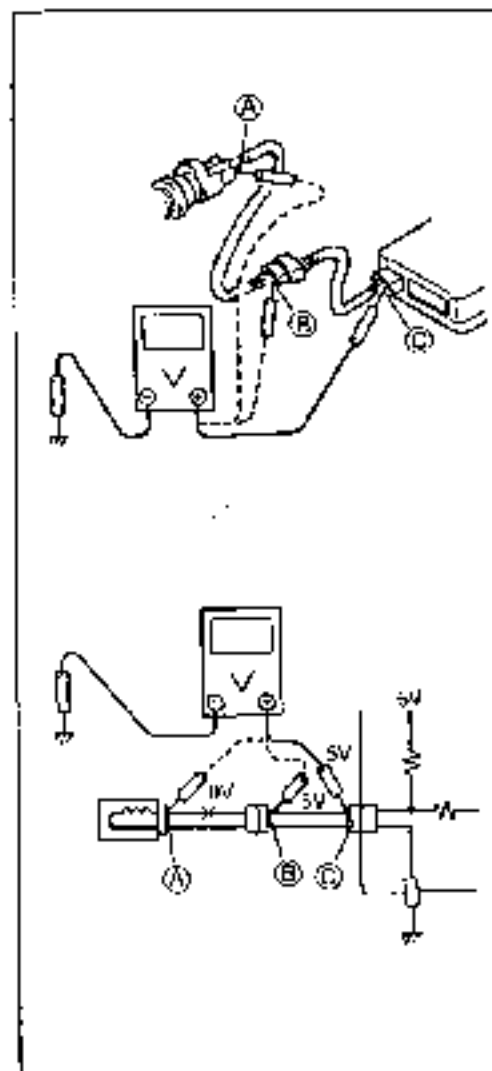

SHORT CIRCUIT CHECK (WIRE HARNESS TO GROUND)

- Disconnect the negative cable from the battery.
- Disconnect the connectors/couplers at both ends of the circuit to be checked.

NOTE:

If the circuit to be checked branches to other parts as shown, disconnect all connectors/couplers of those parts. Otherwise, diagnosis will be misled.

- Measure resistance between terminal at one end of circuit (A terminal in figure) and body ground. If continuity is indicated, there is a short circuit to ground between terminals A and C.

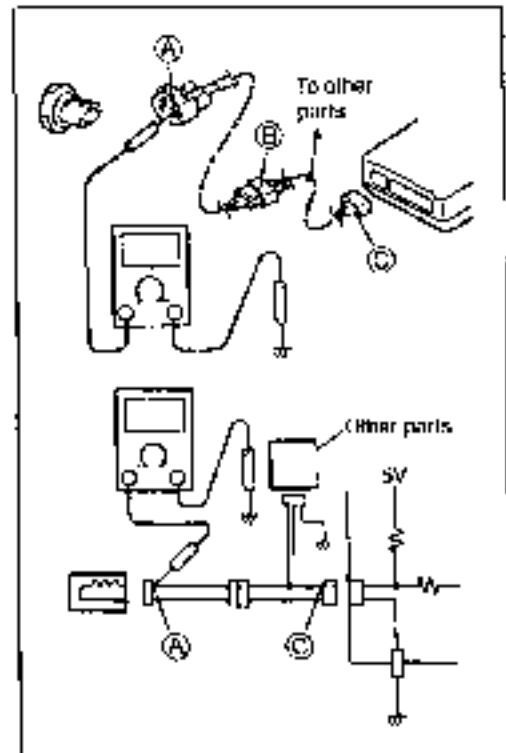

- Disconnect the connector/coupler included in circuit (coupler B) and measure resistance between terminal A and body ground.

If continuity is indicated, the circuit is shorted to the ground between terminals A and B.

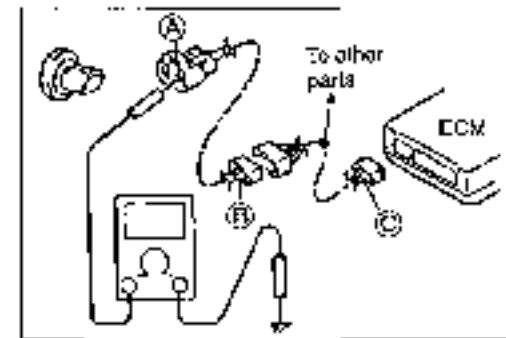

USING TESTERS

- Use the Suzuki multi-circuit tester (09900-25000).
- Use well-charged batteries in the tester.
- Be sure to set the tester to the correct testing range.

USING THE TESTER

- Incorrectly connecting the (+) and (-) probes may cause the inside of the tester to burn out.
- If the voltage and current are not known, make measurements using the highest range.
- When measuring the resistance with the multi-circuit tester, ∞ will be shown as 10.00 MΩ and "1" flashes in the display.
- Check that no voltage is applied before making the measurement. If voltage is applied, the tester may be damaged.
- After using the tester, turn the power off.

09900-25008: Multi-circuit tester

NOTE:

- * When connecting the multi-circuit tester, use a fine needle pointed probe or install fine copper wires (O.D. is below 0.5 mm) to the back side of the lead wire coupler and connect the probes of tester to them.
- * Use a fine copper wire, the outer diameter being below 0.5 mm, to prevent the rubber of the water proof coupler from damage.

MULTI-CIRCUIT TESTER



FI SYSTEM TECHNICAL FEATURES

INJECTION TIME (INJECTION VOLUME)

The factors to determine the injection time include the basic fuel injection time which is calculated on the basis of the intake air pressure, engine speed and throttle opening angle, and various compensations. These compensations are determined according to the signals from various sensors that detect the engine and driving conditions.

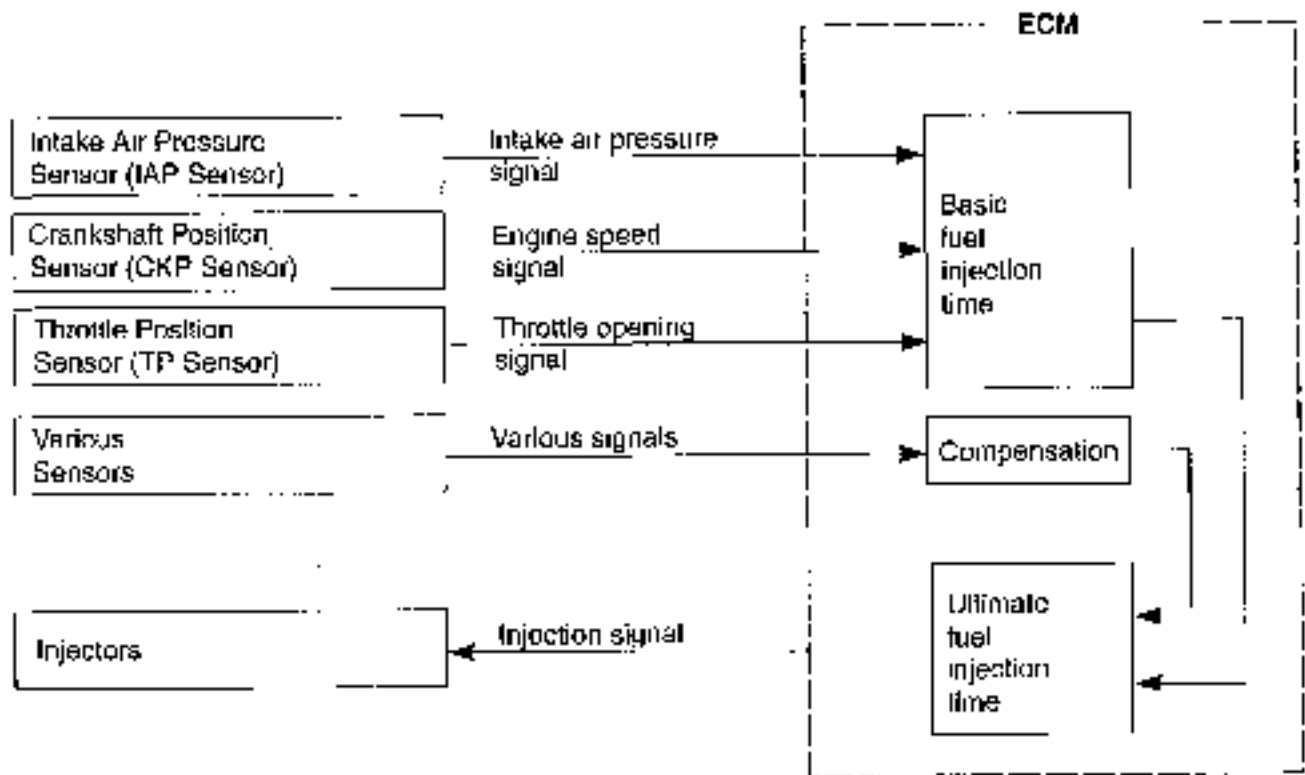

COMPENSATION OF INJECTION TIME (VOLUME)

The following different signals are output from the respective sensors for compensation of the fuel injection time (volume).

SIGNAL	DESCRIPTION
ATMOSPHERIC PRESSURE SENSOR SIGNAL	When atmospheric pressure is low, the sensor sends the signal to the ECM and reduce the injection time (volume).
ENGINE COOLANT TEMPERATURE SENSOR SIGNAL	When engine coolant temperature is low, injection time (volume) is increased.
INTAKE AIR TEMPERATURE SENSOR SIGNAL	When intake air temperature is low, injection time (volume) is increased.
HEATED OXYGEN SENSOR SIGNAL (E-02, 19)	Air/fuel ratio is compensated to the theoretical ratio from density of oxygen in exhaust gases. The compensation occurs in such a way that more fuel is supplied if detected air/fuel ratio is lean and less fuel is supplied if it is rich.
BATTERY VOLTAGE SIGNAL	ECM operates on the battery voltage and at the same time, it monitors the voltage signal for compensation of the fuel injection time (volume). A longer injection time is needed to adjust injection volume in the case of low voltage.
ENGINE RPM SIGNAL	At high speed, the injection time (volume) is increased.
STARTING SIGNAL	When starting engine, additional fuel is injected during cranking engine.
ACCELERATION SIGNAL/ DECELERATION SIGNAL	During acceleration, the fuel injection time (volume) is increased, in accordance with the throttle opening speed and engine rpm. During deceleration, the fuel injection time (volume) is decreased.

INJECTION STOP CONTROL

SIGNAL	DESCRIPTION
TIP OVER SENSOR SIGNAL (FUEL SHUT-OFF)	When the motorcycle tips over, the tip over sensor sends a signal to the ECM. Then, this signal cuts OFF current supplied to the fuel pump, fuel injectors and ignition coils.
OVER-REV. LIMITER SIGNAL	The fuel injectors stop operation when engine rpm reaches rev. limit rpm.

FI SYSTEM PARTS LOCATION

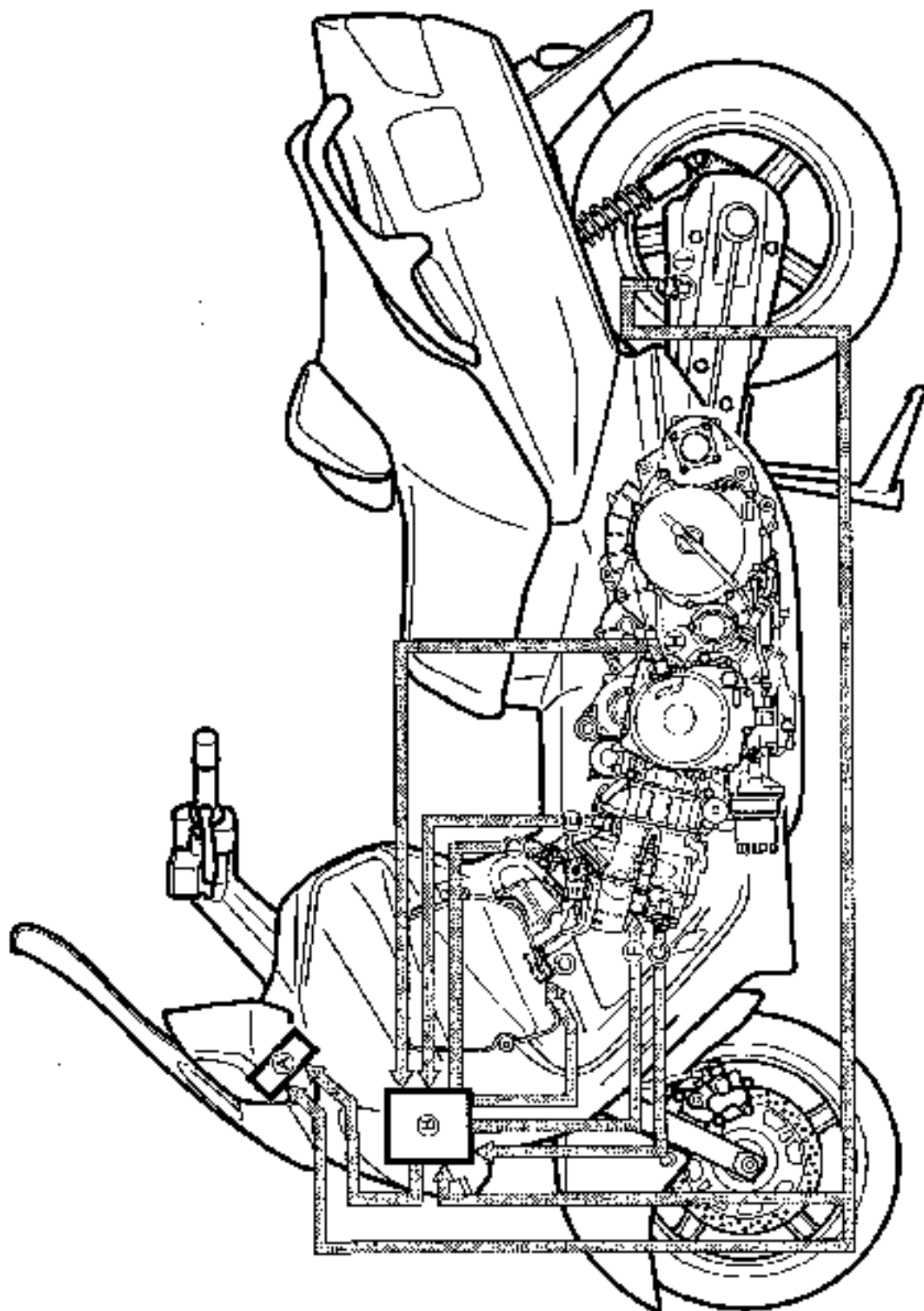

- ① Fuel pump
- ② Camshaft position sensor (CMPS)
- ③ Crankshaft position sensor (CKPS)
- ④ Fuel injector (FI)
- ⑤ Speed sensor
- ⑥ Combination meter
- ⑦ ECM
- ⑧ Air flow sensor (AFS)
- ⑨ Engine coolant temperature sensor (ECTS)
- ⑩ Ignition coil (IG COIL)

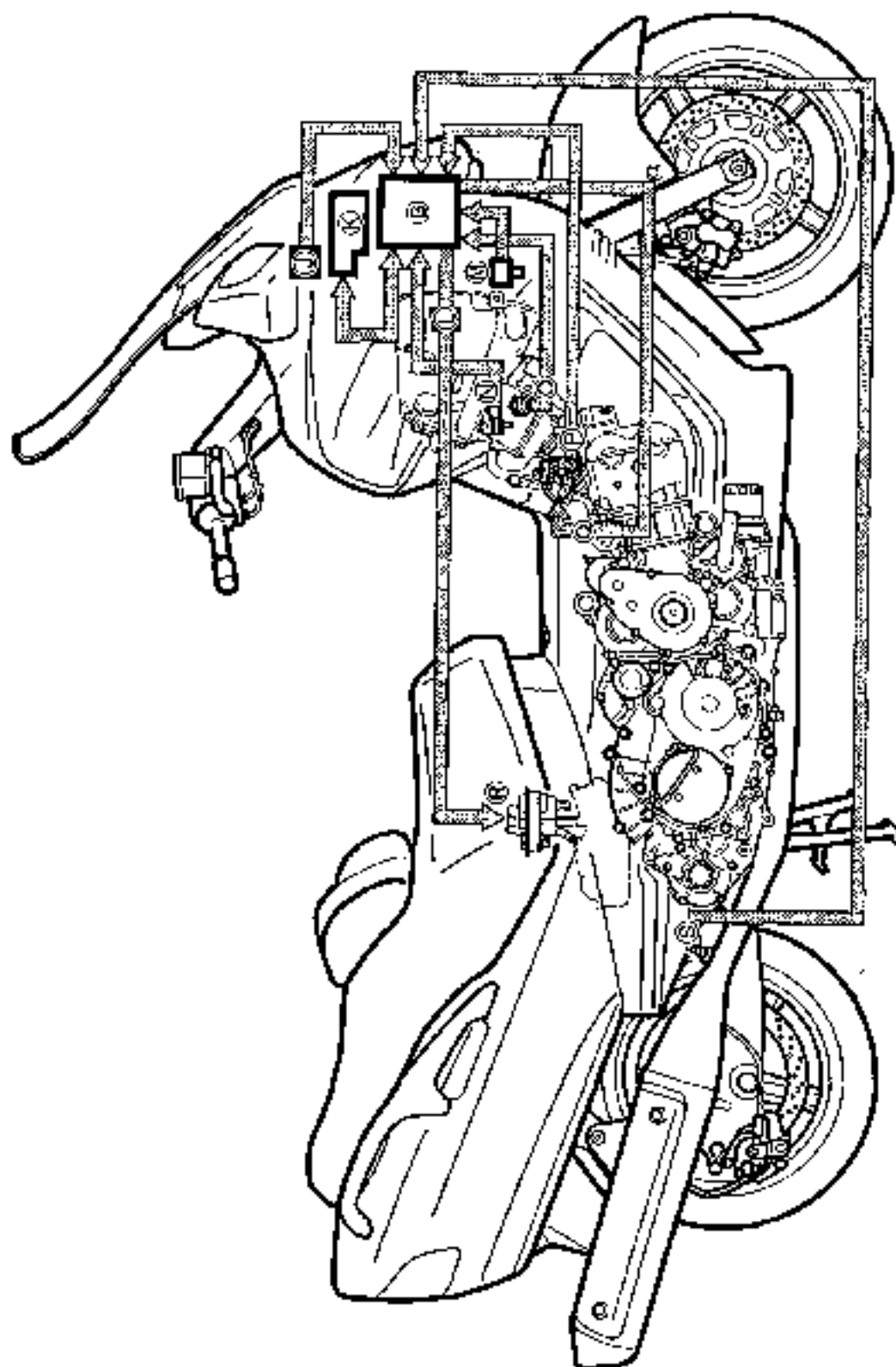

- Ⓐ FCM
- Ⓛ Tip over sensor (TOS)
- Ⓜ CVT control unit
- Ⓝ FUEL PUMP RELAY (FP RELAY)
- Ⓞ Atmospheric pressure sensor (APS)
- Ⓟ Intake air pressure sensor (IAPS)
- Ⓠ Intake air temperature sensor (IATS)
- Ⓡ Throttle position sensor (TPS)
- Ⓢ IAC valve
- Ⓣ Fuel pump (FP)
- Ⓤ Heated oxygen sensor (HO2S) (E-32, 19)

FI SYSTEM WIRING DIAGRAM

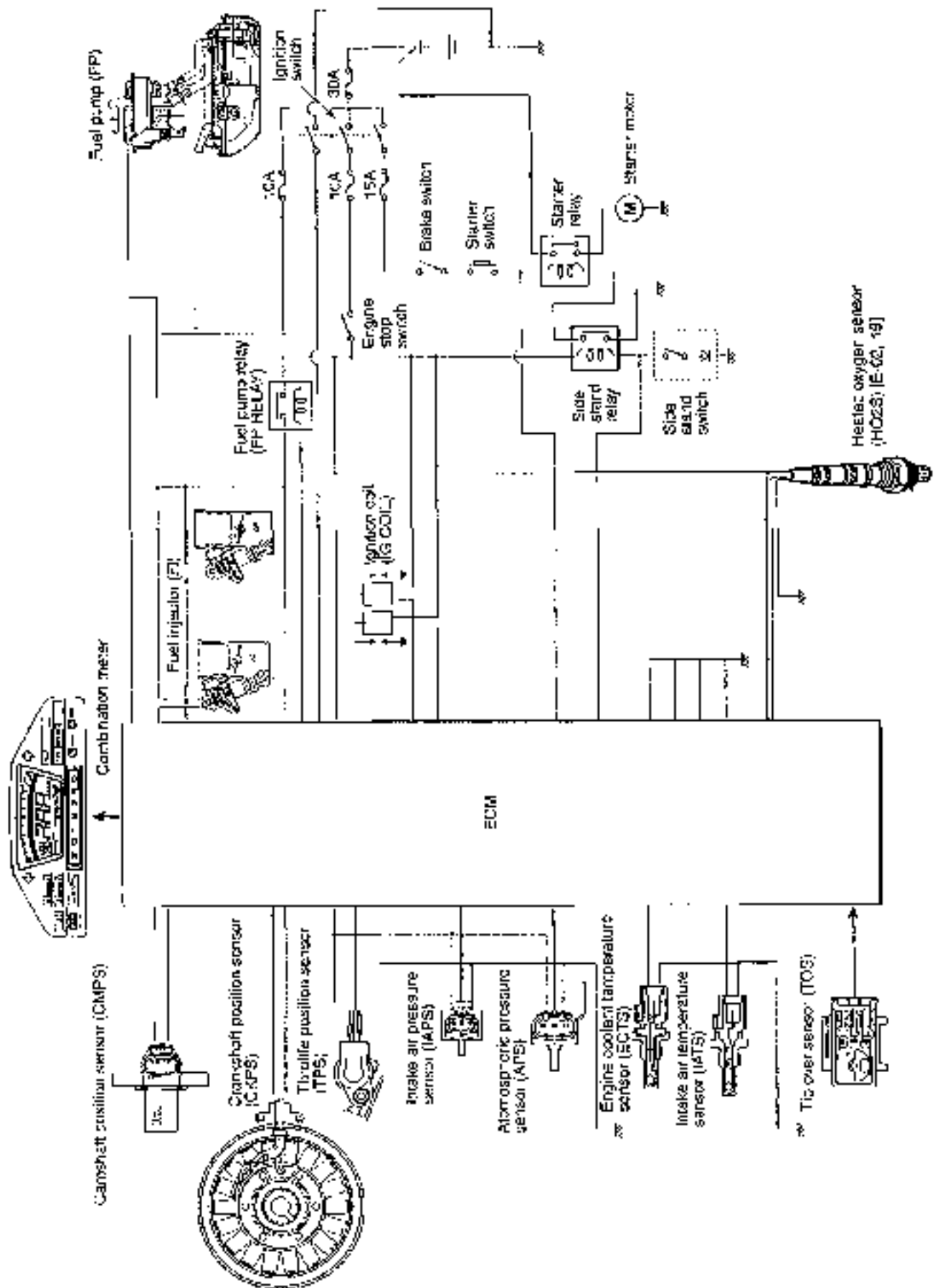

CVT SYSTEM TECHNICAL FEATURES

The CVT reduction ratio is controlled in relation to Actual CVT ratio and Target CVT ratio.

The reduction ratio as detected by the CVT pulley position sensor is compensated for more accurate valve as Actual CVT ratio by comparing with the signals from the crankshaft position sensor and CVT secondary pulley revolution sensor.

Target CVT ratio is calculated on the basis of the target engine speed as determined by the speed sensor and the throttle position sensor.

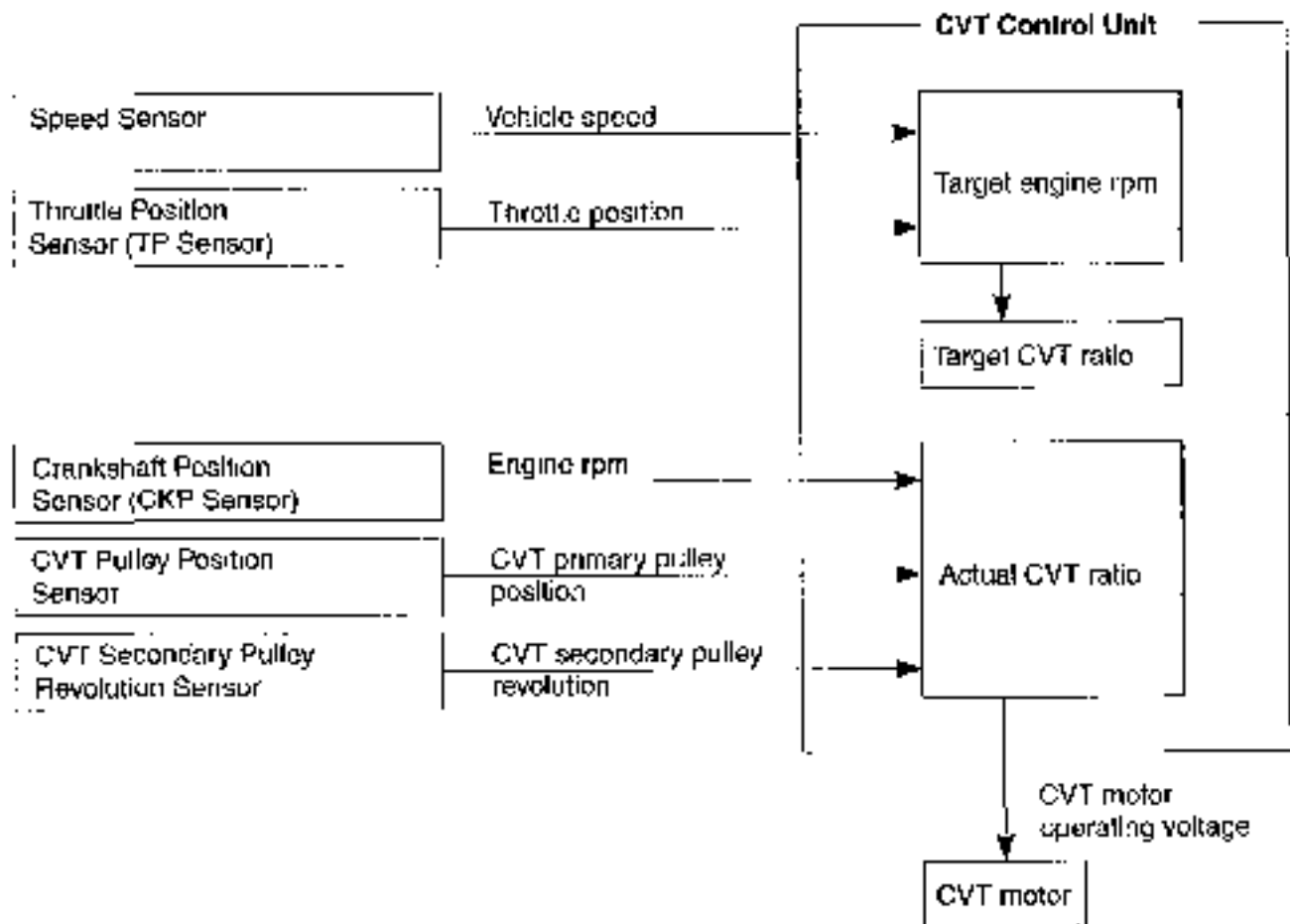

CVT SYSTEM PARTS LOCATION

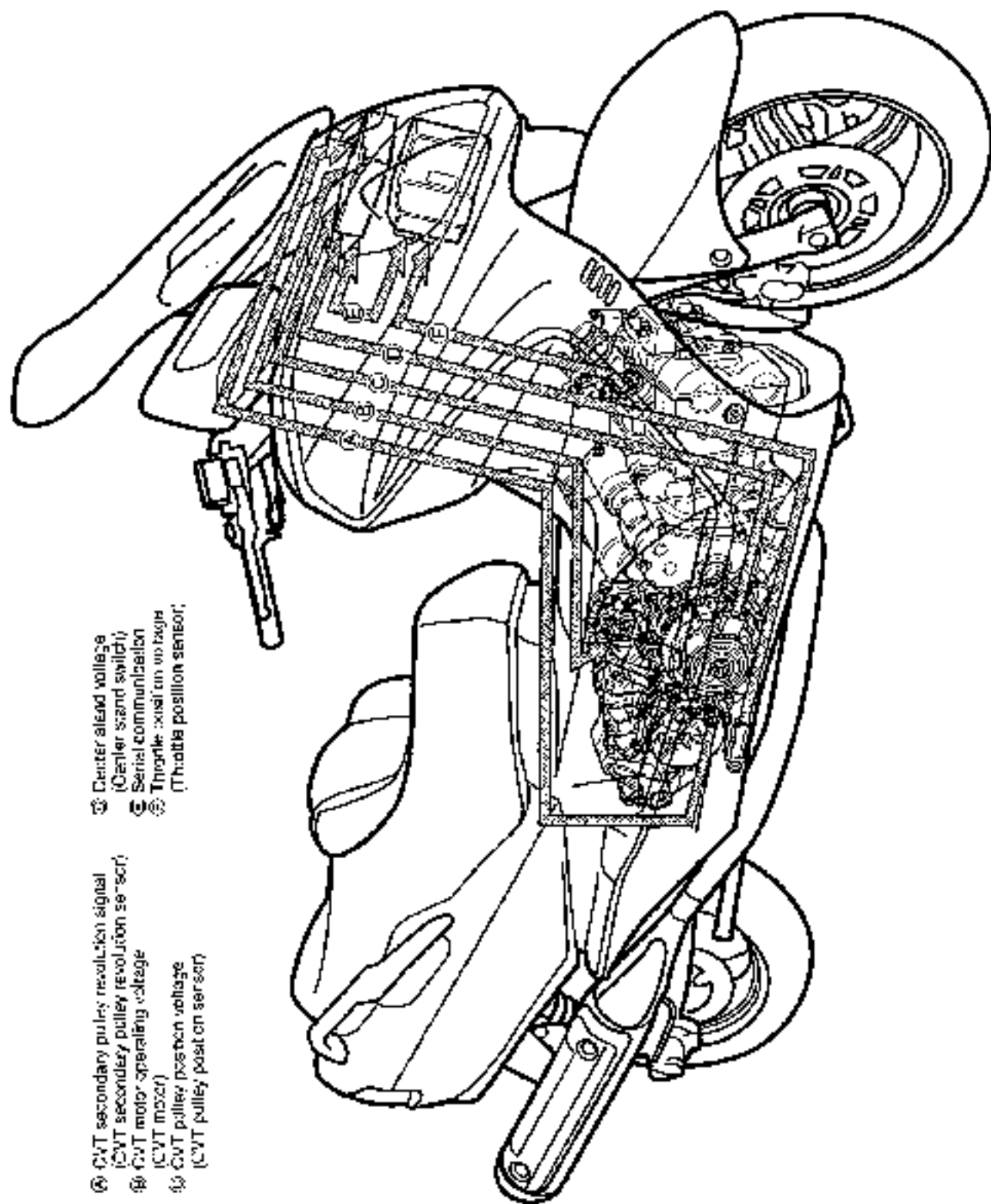

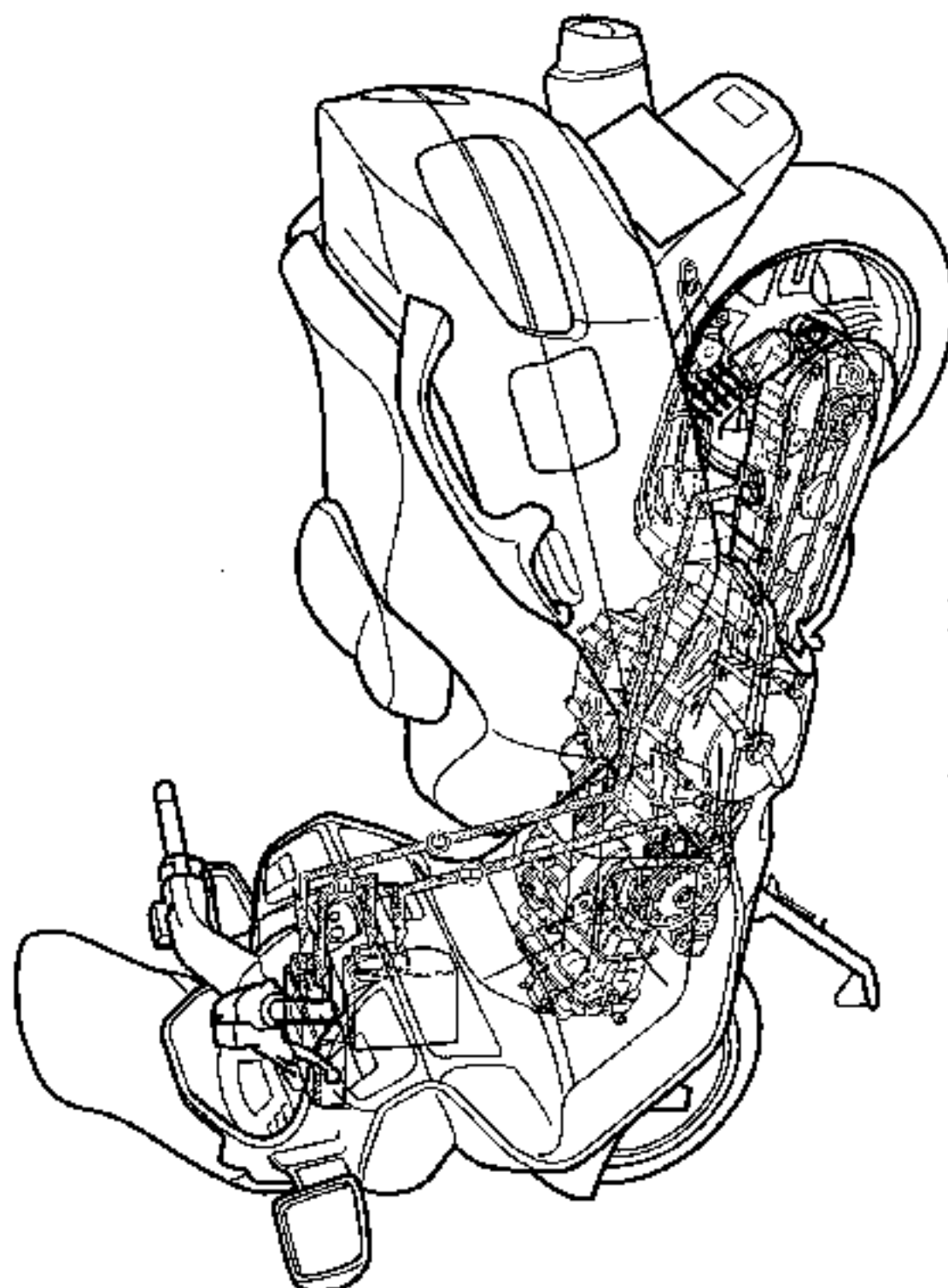

- ⊗ Serial communication
- ⊙ Speed signal (Speed sensor)
- ⊕ Engine rpm (Crankshaft position sensor)

The CVT control unit adjusts the CVT reduction ratio by making the pulley wider or narrower. The slide pulley movement is controlled by the CVT motor revolution.

The secondary pulley squeezes the CVT belt with the spring force and the width of pulley adjusts itself in accordance with that of the primary pulley.

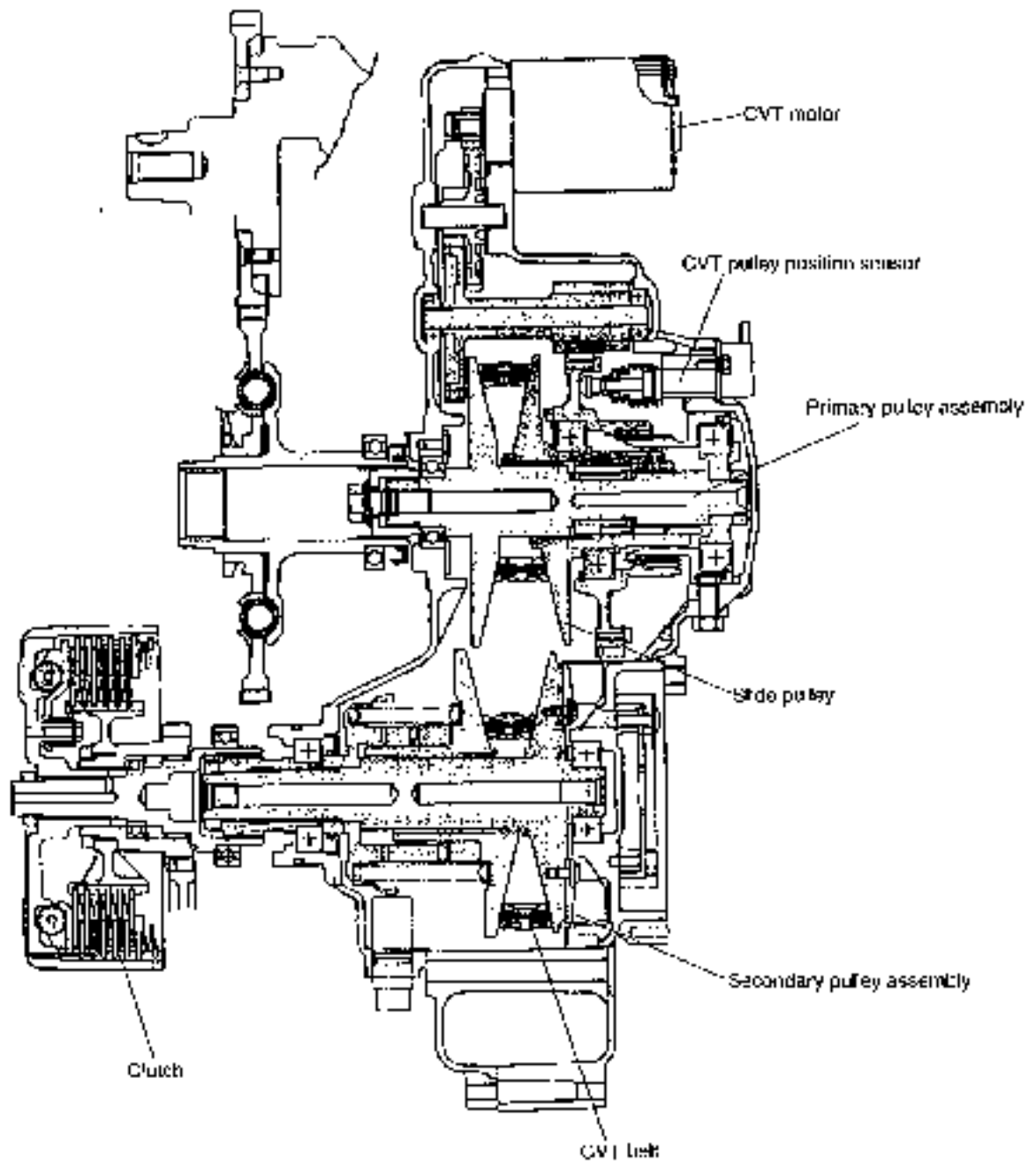

SELF-DIAGNOSIS FUNCTION

The self-diagnosis function is incorporated in the ECM. The function has two modes, "User mode" and "Dealer mode". The user can only be notified by the LCD (DISPLAY) panel and FI light. To check the function of the individual FI system devices, the dealer mode is prepared. In this check, the special tool is necessary to read the code of the malfunction items.

USER MODE

MALFUNCTION	LCD (DISPLAY) INDICATION	FI LIGHT INDICATION	INDICATION MODE
"NO"	Odometer	—	—
"YES"	Odometer and "FI" letters	FI light turns ON.	Each 2 sec. Odometer or "FI" is indicated.
Engine can start	*1		
Engine can not start	"FI" letters *2	FI light turns ON and blinks.	"FI" is indicated continuously.

*1
When one of the signals is not received by ECM, the fail-safe circuit works and injection is not stopped. In this case, "FI" and odometer are indicated in the LCD panel and motorcycle can run.

*2
The injection signal is stopped, when the crankshaft position sensor signal, tip over sensor signal, #1/#2 ignition signals, #1/#2 injector signals, fuel pump relay signal or ignition switch signal is not sent to ECM. In this case, "FI" is indicated in the LCD panel. Motorcycle does not run.

"CHEC": The LCD panel indicates "CHEC" when no communication signal from the ECM is received for 3 seconds.

For Example

: The ignition switch is turned ON, and the engine stop switch is turned OFF. In this case, the speedometer does not receive any signal from the ECM, and the panel indicates "CHEC".

If CHEC is indicated, the LCD does not indicate the trouble code. It is necessary to check the wiring harness between ECM and speedometer couplers.

The possible cause of this indication is as follows:

Engine stop switch is in OFF position. Ignition fuse is burnt.

DEALER MODE

The defective function is memorized in the computer. Use the special tool's coupler to connect to the dealer mode coupler. The memorized malfunction code is displayed on LCD (DISPLAY) panel. Malfunction means that the ECM does not receive signal from the device. These affected devices are indicated in the code form.

 08930-82720: Mode select switch

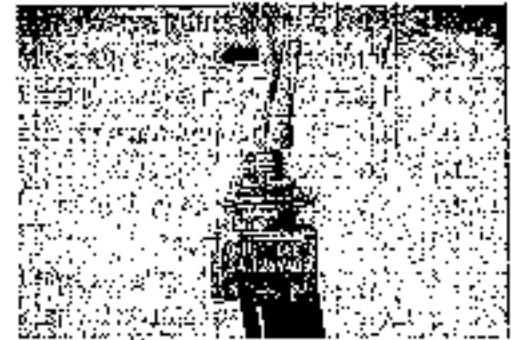
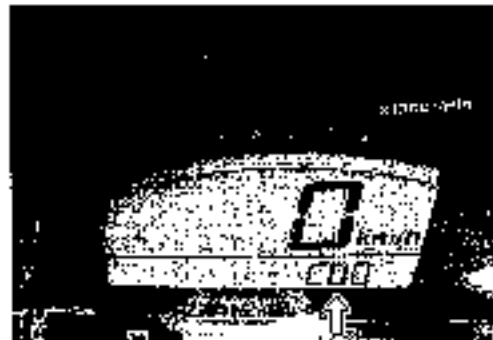

CAUTION

Before checking the malfunction code, do not disconnect the ECM lead wire couplers. If the couplers from the ECM are disconnected, the malfunction code memory is erased and the malfunction code can not be checked.

MALFUNCTION	LCD (DISPLAY) INDICATION	FI LIGHT INDICATION	INDICATION MODE
"NO"	C00		
"YES"	C** code is indicated from small numeral to large one	FI light turns OFF.	For each 2 sec., code is indicated.

CODE	WALFUNCTION PART	REMARKS	
C00	None	No defective part	
C11	Camshaft position sensor (CMPS)	Pick-up coil signal, signal generator	
C12	Crankshaft position sensor (CKPS)		
C13	Intake air pressure sensor (IAPS)		
C14	Throttle position sensor (TPS)		
C15	Engine coolant temp. sensor (ECTS)		
C16	Speed sensor		Speed sensor signal for FI system
C21	Intake air temperature sensor (IATS)		
C22	Atmospheric pressure sensor (APS)		
C23	Tip over sensor (TOS)		
C24	Ignition signal #1 (IG coil #1)		For #1 cylinder
C25	Ignition signal #2 (IG coil #2)		For #2 cylinder
C32	Fuel injector signal #1		For #1 cylinder
C33	Fuel injector signal #2		For #2 cylinder
C40	Idle air control valve (IAC valve)		Fuel pump, Fuel pump relay
C41	Fuel pump control system (FP control system)		
C42	Ignition switch signal (IG switch signal)	Anti-theft	
C44	Heated oxygen sensor (HO2S)	E-02, 19	
C50	CVT serial communication	Speed sensor signal for CVT system	
C51	CVT motor		
C52	CVT pulley position sensor		
C53	CVT speed sensor		
C54	CVT secondary pulley revolution sensor		
C55	CVT engine revolution signal		
C56	CVT throttle position signal		
C58	CVT reduction ratio disagreement		

In the LCD (DISPLAY) panel, the malfunction code is indicated from small code to large code.

TPS ADJUSTMENT

1. Warm up the engine and adjust the engine idle speed to 1200 ± 100 rpm. (☞ 2-18)
2. Stop the engine.
3. Connect the special tool (Mode select switch) and select the dealer mode.
4. If the throttle position sensor adjustment is necessary, loosen the screw and turn the throttle position sensor and bring the line to middle.
5. Then, tighten the screw to fix the throttle position sensor.

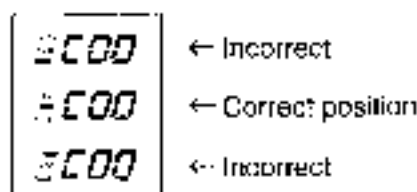

FAIL-SAFE FUNCTION

FI system/CVT system is provided with fail-safe function to allow the engine to start and the motorcycle to run in a minimum performance necessary even under malfunction condition.

ITEM	FAIL-SAFE MODE	STARTING ABILITY	RUNNING ABILITY
Camshaft position sensor	When camshaft position signal has failed during running, the ECM determines cylinder as # before occurrence of such a failure.	"NO"	"YES"
		Motorcycle can run, but once engine stops, engine can not start.	
Crankshaft position sensor	The motorcycle stops.	"NO"	"NO"
Intake air pressure sensor	Intake air pressure is fixed to 760 mmHg.	"YES"	"YES"
Throttle position sensor	The throttle opening is fixed to full open position. Ignition timing is also fixed.	"YES"	"YES"
Engine coolant temp. sensor	Engine coolant temperature value is fixed to 80 °C.	"YES"	"YES"
Intake air temperature sensor	Intake air temperature value is fixed to 40 °C.	"YES"	"YES"
Atmospheric pressure sensor	Atmospheric pressure is fixed to 760 mmHg.	"YES"	"YES"
Ignition signal #1 (IG coil #1)	#1 Ignition-off	"YES"	"YES"
		#2 cylinder can run.	
Ignition signal #2 (IG coil #2)	#2 Ignition-off	"YES"	"YES"
		#1 cylinder can run.	
Injection signal #1	#1 Fuel-cut	"YES"	"YES"
		#2 cylinder can run.	
Injection signal #2	#2 Fuel-cut	"YES"	"YES"
		#1 cylinder can run.	
HO2 sensor (E-02, 19)	Feedback compensation is inhibited. (Air/fuel ratio is fixed to normal.)	"YES"	"YES"
CVT motor	Current supply to motor is interrupted.	"YES"	"YES"
CVT pulley position sensor	Automatic mode: Shifting to manual mode is inhibited. Reduction ratio is fixed to an equivalent to 2nd range.	"YES"	"YES"
CVT speed sensor	Manual mode: During running on 2nd or higher range, the reduction ratio is fixed to an equivalent to 2nd range. If running on 1st range, it is fixed to 1st range.	"YES"	"YES"
CVT secondary pulley revolution sensor	All shifting is inhibited.	"YES"	"YES"
CVT engine revolution signal		"YES"	"YES"
CVT throttle position signal	Throttle position signal is fixed to 30% open.	"YES"	"YES"

The engine can start and can run even if the above signal is not received from each sensor. But, the engine running condition is not complete, providing only emergency help (by fail-safe circuit). In this case, it is necessary to bring the motorcycle to the workshop for complete repair.

FI SYSTEM/ CVT SYSTEM TROUBLESHOOTING

CUSTOMER COMPLAINT ANALYSIS

Record details of the problem (failure, complaint) and how it occurred as described by the customer. For this purpose, use of such an inspection form will facilitate collecting information to the point required for proper analysis and diagnosis.

EXAMPLE: CUSTOMER PROBLEM INSPECTION FORM

User name:	Model:	VIN:	CVT No.:
Date of issue:	Date Reg.:	Date of problem:	Mileage:

Shift mode	<input type="checkbox"/> Automatic (Normal-Power) <input type="checkbox"/> Manual (1st-2nd-3rd-4th-5th)
Malfunction indicator lamp condition (LED)	<input type="checkbox"/> Always ON <input type="checkbox"/> Sometimes ON <input type="checkbox"/> Always OFF <input type="checkbox"/> Good condition
Malfunction display/code (LCD)	User mode: <input type="checkbox"/> No display <input type="checkbox"/> Malfunction display ()
	Dealer mode: <input type="checkbox"/> No code <input type="checkbox"/> Malfunction code ()

PROBLEM SYMPTOMS

<input type="checkbox"/> Difficult Starting <input type="checkbox"/> No cranking <input type="checkbox"/> No initial combustion <input type="checkbox"/> No combustion <input type="checkbox"/> Poor starting at <input type="checkbox"/> cold <input type="checkbox"/> warm <input type="checkbox"/> always) <input type="checkbox"/> Other _____	<input type="checkbox"/> Poor Driveability <input type="checkbox"/> Hesitation on acceleration <input type="checkbox"/> Back fire/ <input type="checkbox"/> After fire <input type="checkbox"/> Lack of power <input type="checkbox"/> Surging <input type="checkbox"/> Abnormal knocking <input type="checkbox"/> CVT will not shift <input type="checkbox"/> Engine rpm jumps briefly <input type="checkbox"/> Other _____
<input type="checkbox"/> Poor Idling <input type="checkbox"/> Poor fast idle <input type="checkbox"/> Abnormal idling speed <input type="checkbox"/> High <input type="checkbox"/> Low (r/min) <input type="checkbox"/> Unstable <input type="checkbox"/> Hunting (r/min. to r/min) <input type="checkbox"/> Other _____	<input type="checkbox"/> Engine Stall when <input type="checkbox"/> Immediately after start <input type="checkbox"/> Throttle valve is opened <input type="checkbox"/> Throttle valve is closed <input type="checkbox"/> Load is applied <input type="checkbox"/> Other _____
<input type="checkbox"/> OTHERS: _____	

MOTORCYCLE/ENVIRONMENTAL CONDITION WHEN PROBLEM OCCURS	
Environmental condition	
Weather	<input type="checkbox"/> Fair <input type="checkbox"/> Cloudy <input type="checkbox"/> Rain <input type="checkbox"/> Snow <input type="checkbox"/> Always <input type="checkbox"/> Other
Temperature	<input type="checkbox"/> Hot <input type="checkbox"/> Warm <input type="checkbox"/> Cool <input type="checkbox"/> Cold (°F/ °C) <input type="checkbox"/> Always
Frequency	<input type="checkbox"/> Always <input type="checkbox"/> Sometimes (times/ day, month) <input type="checkbox"/> Only once <input type="checkbox"/> Under certain condition
Road	<input type="checkbox"/> Urban <input type="checkbox"/> Suburb <input type="checkbox"/> Highway <input type="checkbox"/> Mountainous (<input type="checkbox"/> Uphill <input type="checkbox"/> Downhill) <input type="checkbox"/> Tarmacadam <input type="checkbox"/> Gravel <input type="checkbox"/> Other
Motorcycle condition	
Engine condition	<input type="checkbox"/> Cold <input type="checkbox"/> Warming up phase <input type="checkbox"/> Warm, cold up : <input type="checkbox"/> Always <input type="checkbox"/> Other at starting <input type="checkbox"/> Immediately after start <input type="checkbox"/> Racing without load <input type="checkbox"/> Engine speed (r/min)
Motorcycle condition	During driving: <input type="checkbox"/> Constant speed <input type="checkbox"/> Accelerating <input type="checkbox"/> Decelerating <input type="checkbox"/> Right hand corner <input type="checkbox"/> Left hand corner <input type="checkbox"/> When shifting (Gear position) <input type="checkbox"/> At stop <input type="checkbox"/> Motorcycle speed when problem occurs (km/h, Mile/h) <input type="checkbox"/> Other _____

NOTE:

The above form is a standard sample. It should be modified according to conditions characteristic of each market.

SELF-DIAGNOSTIC PROCEDURES

- Don't disconnect couplers from ECM/CVT control unit, battery cable from battery, ECM ground wire harness from engine or main fuse before confirming malfunction code (self-diagnostic trouble code) stored in memory. Such disconnection will erase memorized information in ECM memory.
- Malfunction code stored in ECM memory can be checked by the special tool.
- Before checking malfunction code, read SELF-DIAGNOSIS FUNCTION "USER MODE and DEALER MODE" (CJF6-18) carefully to have good understanding as to what functions are available and how to use it.
- Be sure to read "PRECAUTIONS for Electrical Circuit Service" (CJF6-2) before inspection and observe what is written there.
- Lift the seat.
- Connect the special tool to the dealer mode coupler (A) at the wiring harness, and start the engine or crank the engine for more than 4 seconds.
- Turn the special tool's switch ON and check the malfunction code to determine the malfunction part.

 09930-82720: Mode select switch

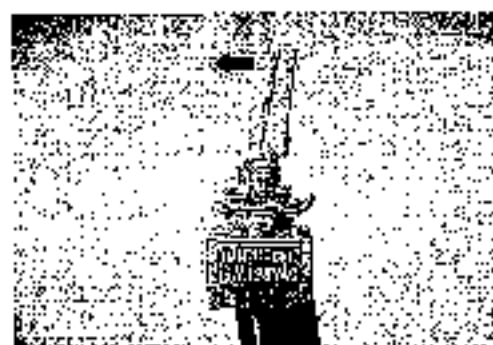

SELF-DIAGNOSIS RESET PROCEDURE

- After repairing the trouble, turn OFF the ignition switch and turn ON again.
- If the malfunction code indicates (C00), the malfunction is cleared.
- Disconnect the special tool from the dealer mode coupler.



MALFUNCTION CODE AND DEFECTIVE CONDITION

MALFUNCTION CODE	DETECTED ITEM	DETECTED FAILURE CONDITION
		CHECK FOR
C00	NO FAULT	
C11	Camshaft position sensor	The signal does not reach ECM for more than 2 sec. after receiving the starter signal. The camshaft position sensor wiring and mechanical parts. (Camshaft position sensor, intake cam pin, wiring/coupler connection)
C12	Crankshaft position sensor	The signal does not reach ECM for more than 2 sec. after receiving the starter signal. The crankshaft position sensor wiring and mechanical parts. (Crankshaft position sensor, wiring/coupler connection)
C13	Intake air pressure sensor	The sensor should produce following voltage. (0.50 V \leq sensor voltage < 4.85 V) Without the above range, C13 is indicated. Intake air pressure sensor, wiring/coupler connection.
C14	Throttle position sensor	The sensor should produce following voltage. (0.20 V \leq sensor voltage < 4.80 V) Without the above range, C14 is indicated. Throttle position sensor, wiring/coupler connection
C15	Engine coolant temperature sensor	The sensor voltage should be the following. (0.15 V \leq sensor voltage < 4.85 V) Without the above range, C15 is indicated. Engine coolant temperature sensor, wiring/coupler connection.
C16	Speed sensor	The speed sensor signal is not input for more than 3 sec. during vehicle deceleration. Speed sensor, wiring/coupler connection.
C21	Intake air temperature sensor	The sensor voltage should be the following. (0.15 V \leq sensor voltage < 4.85 V) Without the above range, C21 is indicated. Intake air temperature sensor, wiring/coupler connection.
C22	Atmospheric pressure sensor	The sensor voltage should be the following. (0.50 V \leq sensor voltage < 4.85 V) Without the above range, C22 is indicated. Atm. pressure sensor, wiring/coupler connection
C23	Tip over sensor	The sensor voltage should be the following for more than 2 sec. after ignition switch turns ON. (0.20 V \leq sensor voltage < 4.80 V) Without the above value, C23 is indicated. Tip over sensor, wiring/coupler connection
C24 or C25	Ignition signal	Crankshaft position sensor (pick-up coil) signal is produced but signal from ignition coil is interrupted continuous by 4 times or more. In this case, the code C24 or C25 is indicated. Ignition coil, wiring/coupler connection, power supply from the battery.

C32 or C33	Fuel injector	Crankshaft position sensor (pick-up coil) signal is produced but fuel injector signal is interrupted continuously by 4 times or more. In this case, the code C32 or C33 is indicated. Injector, wiring/coupler connection, power supply to the injector.
C40	Intake air control (IAC) valve	No IAC valve voltage is supplied after starting the engine. IAC valve, wiring/coupler connection.
C41	Fuel pump relay	No voltage is applied to fuel pump although fuel pump relay is turned ON, or voltage is applied to fuel pump although fuel pump relay is turned OFF. Fuel pump relay, connecting lead, power source to fuel pump relay.
C42	Ignition switch	Ignition switch signal is not input in the ECM. Ignition switch, lead wire/coupler.
C44	Heated oxygen sensor (HO2S) [E-02, 19]	During O ₂ feedback control, O ₂ sensor generating voltage is as follows. (Sensor voltage < 0.45). The heater circuit disconnection is detected during engine operation, or no electrical power is supplied from battery. HO2S lead wire/coupler connection. Battery voltage supply to the HO2S.
C50	CVT serial communication	No signal is supplied from CVT control unit to ECM for more than 5 sec after starting the engine. Wiring/coupler connection.
C51	CVT motor	The CVT motor operating voltage is not supplied from CVT control unit. CVT motor, wiring/coupler connection.
C52	CVT pulley position sensor	The sensor should produce following voltage. (0.06 ≤ sensor voltage ≤ 5.04) Without the above range, C52 is indicated. CVT pulley position sensor, wiring/coupler connection.
C53	CVT speed sensor	The CVT speed sensor signal is not input to CVT control unit for more than 3 sec during vehicle running. Speed sensor, wiring/coupler connection.
C54	CVT secondary pulley revolution sensor	The CVT secondary pulley revolution signal is not input to CVT control unit at speed of 20 km or higher. CVT secondary pulley revolution sensor, wiring/coupler connection.
C55	CVT engine revolution signal	The CVT engine revolution signal is not input to CVT control unit from ECM at speed of 20 km or higher. Wiring/coupler connection.
C56	CVT throttle position signal	The CVT throttle position signal does not reach for more than 5 sec from ECM to CVT control unit after ignition switch turns ON. Wiring/coupler connection.
C58	CVT reduction ratio disagreement	The CVT pulley position signal disagrees with actual revolution ratio for more than 4 sec. PPS, CVT ball, CVT primary pulley/secondary pulley.

"C11" CMP SENSOR CIRCUIT MALFUNCTION

DETECTED CONDITION	POSSIBLE CAUSE
No CMP sensor signal for more than 2 seconds after receiving the starter signal.	<ul style="list-style-type: none"> • Metal particles or foreign material being attached on the CMP sensor and rotor lip • CMP sensor circuit open or short. • CMP sensor malfunction. • ECM malfunction.

INSPECTION

- Remove the maintenance lid. (9-13)

1 Turn the ignition switch OFF.
Check the CMP sensor coupler for loose or poor contacts. If OK, then measure the CMP sensor resistance. Disconnect the CMP sensor coupler (1) and measure the resistance.

DATA CMP sensor resistance: 0.9 – 1.7 k Ω
(B/Y – Brown)

If OK, then check the continuity between each terminal and ground.

DATA CKP sensor continuity: $\infty \Omega$ (Infinity)
(B/Y – Ground)
(Br – Ground)

TOOL 09900-25008: Multi circuit tester

TESTER Tester knob indication: Resistance (Ω)

No → Replace the CMP sensor with a new one.

Yes →

2 Disconnect the CMP sensor coupler.
Crank the engine a few seconds with the starter motor, and measure the CMP sensor peak voltage at the sensor.

DATA CMP sensor peak voltage: More than 0.5 V
(\oplus B/Y – (\ominus)Br)

Repeat the above test procedure a few times and measure the highest peak voltage.

If OK, then measure the CMP sensor peak voltage at the ECM terminals. (9-14)

TOOL 09900-25008: Multi circuit tester

TESTER Tester knob indication: Voltage (V)

No → Loose or poor contacts on the CMP sensor coupler or ECM coupler. Replace the CMP sensor with a new one.

Yes →

B/Y or Br wire open or shorted to ground, or poor (1) or (2) connection.

If wire and connection are OK, intermittent trouble or faulty ECM. Recheck each terminal and wire harness for open circuit and poor connection.

Replace the ECM with a new one, and inspect it again.

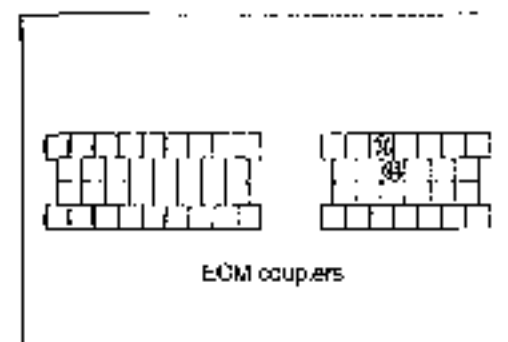
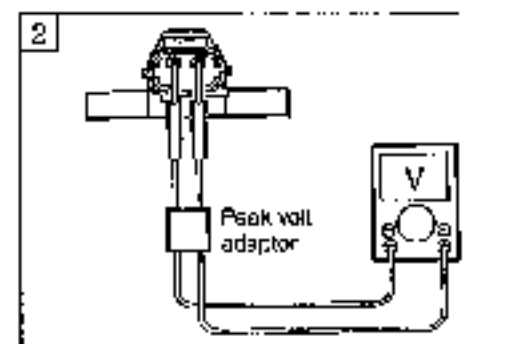
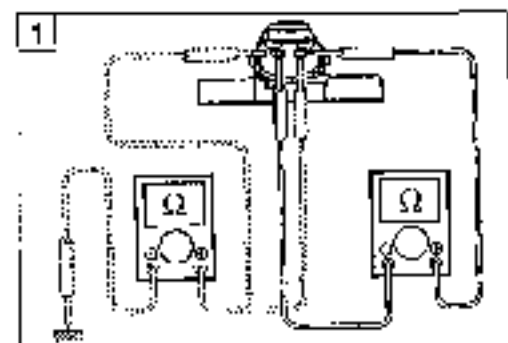

"C12" CKP SENSOR CIRCUIT MALFUNCTION

DETECTED CONDITION	POSSIBLE CAUSE
No CKP sensor signal for more than 2 seconds after receiving the starter signal.	<ul style="list-style-type: none"> • Metal particles or foreign material being attached on the CKP sensor and rotor tip. • CKP sensor circuit open or short. • CKP sensor malfunction • ECM malfunction.

INSPECTION

- Remove the maintenance lid. (C-9-13)

- 1** Turn the ignition switch OFF.
Check the CKP sensor coupler for loose or poor contacts.
If OK, then measure the CKP sensor resistance.
Disconnect the CKP sensor coupler (1) and measure the resistance.

DATA CKP sensor resistance: 150 - 300 Ω
(Blue - Green)

If OK, then check the continuity between each terminal and ground.

DATA CKP sensor continuity: $\infty \Omega$ (Infinity)
(Blue - Ground)
(Green - Ground)

09900-25008: Multi circuit tester

Tester knob indication: Resistance (Ω)

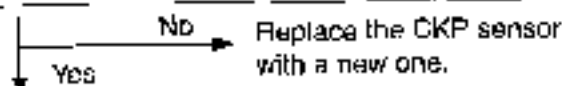

- 2** Disconnect the CKP sensor coupler.
Crank the engine a few seconds with the starter motor, and measure the CKP sensor peak voltage at the coupler.

DATA CKP sensor peak voltage: More than 2.0 V
(Blue - Green)

Repeat the above last procedure a few times and measure the highest peak voltage.

If OK, then measure the CKP sensor peak voltage at the ECM terminals. (2)(3)

09900-25008: Multi circuit tester

Tester knob indication: Voltage (V)

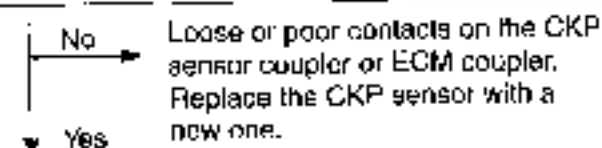

B1 or G1 wire open or shorted to ground, or poor (2) or (3) connection.

If wire and connection are OK, intermittent trouble or faulty ECM.
Recheck each terminal and wire harness for open circuit and poor connection.

→ Replace the ECM with a new one, and inspect it again.

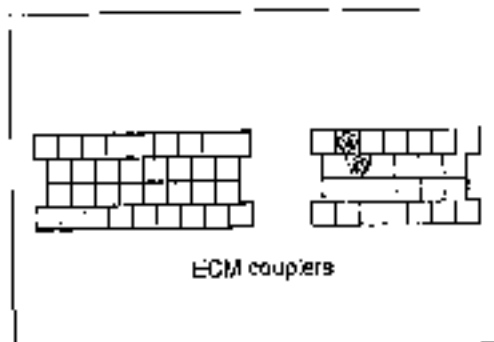
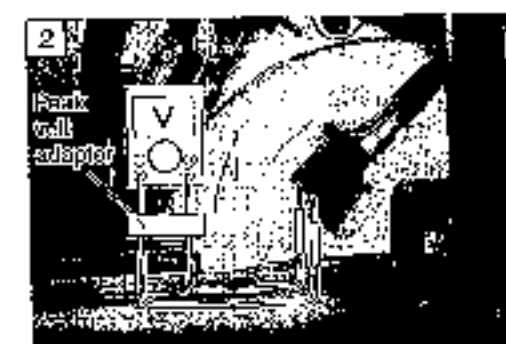
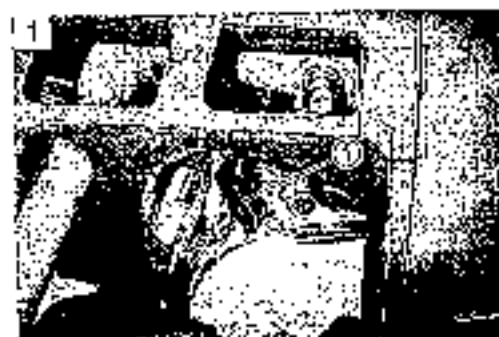

"C13" IAP SENSOR CIRCUIT MALFUNCTION

DETECTED CONDITION	POSSIBLE CAUSE
IAP sensor voltage low or high. $(0.50 \text{ V} \leq \text{Sensor voltage} < 4.85 \text{ V})$ without the above range. NOTE: <i>Note that atmospheric pressure varies depending on weather conditions as well as altitude. Take that into consideration when inspecting voltage.</i>	<ul style="list-style-type: none"> • Clogged vacuum passage between throttle body and IAP sensor. • Air being drawn from vacuum passage between throttle body and IAP sensor. • IAP sensor circuit open or shorted to ground. • IAP sensor malfunction • ECM malfunction.

INSPECTION

- Remove the front box. (C-79-1B)

- 1 Turn the ignition switch OFF.
Check the IAP sensor coupler for loose or poor contacts. If OK, then measure the IAP sensor input voltage. Disconnect the IAP sensor coupler. Turn the ignition switch ON. Measure the voltage at the Red wire and ground. If OK, then measure the voltage at the Red wire and B/Br wire.

DATA IAP sensor input voltage: 4.5 – 5.5 V

(⊕Red – ⊖Ground)
(⊕Red – ⊖B/Br)

TOOL 09900-25008: Multi circuit tester

TESTER Tester knob indication: Voltage (—)

No → Loose or poor contacts on the ECM coupler.
Open or short circuit in the Red wire or B/Br wire.

Yes

- 2 Connect the IAP sensor coupler. Insert the copper wires to the lead wire coupler. Start the engine at idle speed. Measure the IAP sensor output voltage at the wire side coupler (between Lg/B and B/Br wires).

DATA IAP sensor output voltage: Approx. 2.6 V at idle speed (⊕Lg/B – ⊖B/Br)

TOOL 09900-25008: Multi circuit tester

TESTER Tester knob indication: Voltage (—)

No → Check the vacuum hose for crack or damage.
Open or short circuit in the Lg/B wire.
Replace the IAP sensor with a new one.

Yes

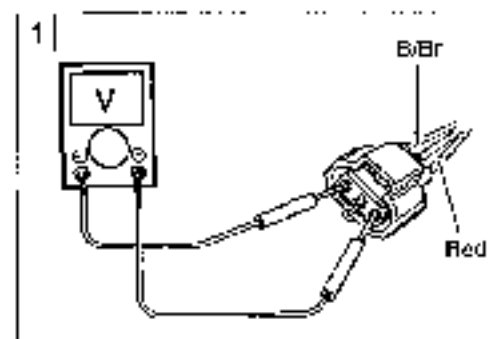
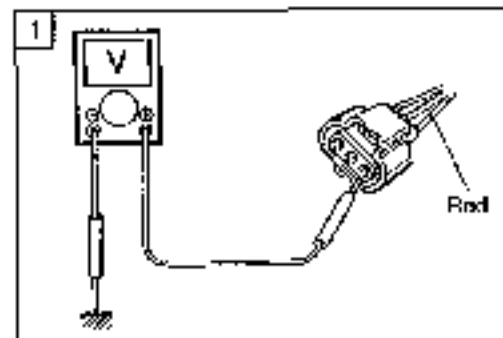

3 Remove the IAP sensor.
 Connect the vacuum pump gauge to the vacuum port of the IAP sensor.
 Arrange 3 new 1.5 V batteries in series (check that total voltage is 4.5 - 5.0 V) and connect (-) terminal to the ground terminal and (+) terminal to the Vcc terminal.
 Check the voltage between Vout and ground. Also, check if voltage reduces when vacuum is applied up to 40 cmHg by using vacuum pump gauge. (See table below.)

09917-47010: Vacuum pump gauge
09900-25008: Multi circuit tester

Tester knob indication: Voltage (V)

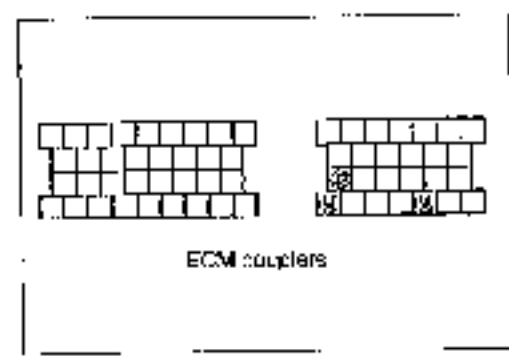
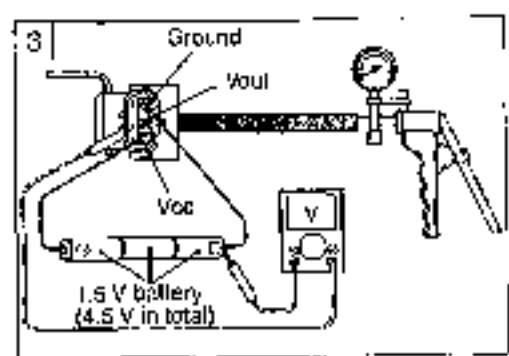

No → If check result is not satisfactory, replace IAP sensor with a new one.

Yes →

Red, Lg/B or B/B wire open or shorted to ground, or poor (+) or (-) connection.
 If wire and connection are OK, intermittent trouble or faulty ECM.
 Recheck each terminal and wire harness for open circuit and poor connection.

→ Replace the ECM with a new one, and inspect it again.

Output voltage (Vcc voltage 4.5 - 5.0 V, ambient temp. 20 - 30 °C, 68 - 86 °F)

ALTITUDE (Reference)		ATMOSPHERIC PRESSURE		OUTPUT VOLTAGE (V)
(ft)	(m)	(mmHg)	kPa	
0	0	760	100	3.1 - 3.6
2 000	610	707	94	
2 001	611	707	94	2.8 - 3.4
5 000	1 524	634	85	
5 001	1 525	634	85	2.6 - 3.1
8 000	2 438	567	76	
8 001	2 439	567	76	2.4 - 2.9
10 000	3 048	528	70	

"C14" TP SENSOR CIRCUIT MALFUNCTION

DETECTED CONDITION	POSSIBLE CAUSE
Output voltage low or high. ($0.20\text{ V} \leq \text{Sensor voltage} < 4.80\text{ V}$) without the above range.	<ul style="list-style-type: none"> • TP sensor maladjusted. • TP sensor circuit open or short. • TP sensor malfunction. • ECM malfunction.

INSPECTION

- Remove the maintenance lid. (☐ 9-13)

- 1 Turn the ignition switch OFF.
Check the TP sensor coupler for loose or poor contacts.
If OK, then measure the TP sensor input voltage.
Disconnect the TP sensor coupler (1).
Turn the ignition switch ON.
Measure the voltage at the Red wire and ground.
If OK, then measure the voltage at the Red wire and B/Br wire.

DATA TP sensor input voltage: 4.5 – 5.5 V
(⊕Red – ⊖Ground)
(⊕Red – ⊖B/Br)

09900-25008: Multi circuit tester

Tester knob indication: Voltage (V)

No → Loose or poor contacts on the ECM coupler.
Open or short circuit in the Red wire or B/Br wire.

Yes ↓

- 2 Turn the ignition switch OFF.
Disconnect the TP sensor coupler.
Check the continuity between Yellow wire and ground.

DATA TP sensor continuity: $\infty \Omega$ (Infinity)
(Yellow wire – Ground)

If OK, then measure the TP sensor resistance at the coupler (between Yellow and Gr or R wires).
Turn the throttle grip and measure the resistance.

DATA TP sensor resistance
Throttle valve is closed : Approx. 1.1 k Ω
Throttle valve is opened : Approx. 4.2 k Ω

09900-25008: Multi circuit tester

Tester knob indication: Resistance (Ω)

No → Reset the TP sensor position correctly.
Replace the TP sensor with a new one.

Yes ↓

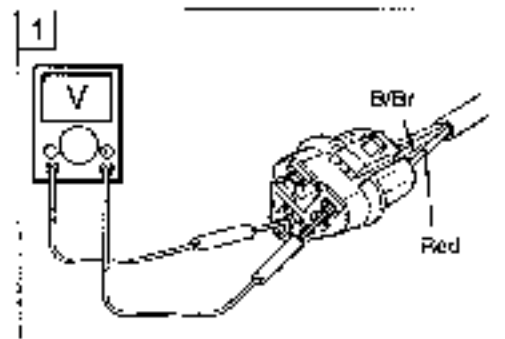
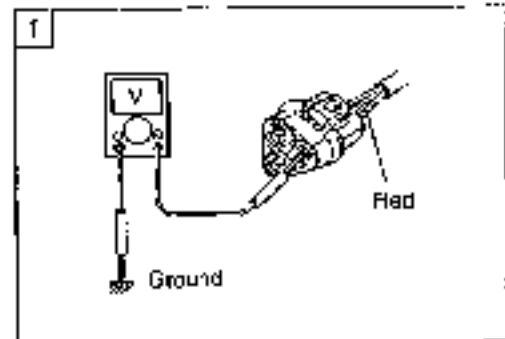

- 3] Connect the TP sensor coupler.
 Insert the copper wires to the lead wire coupler.
 Turn the ignition switch ON.
 Measure the TP sensor output voltage at the coupler (between Yellow and Gr or H wires) by turning the throttle grip.

DATA TP sensor output voltage
 Throttle valve is closed : Approx. 1.1 V
 Throttle valve is opened : Approx. 4.3 V

09900-26005: Multi circuit tester

Tester knob indication: Voltage (—)

No → If check result is not satisfactory,
 replace TP sensor with a new one.

Yes

Red, P/B or B/Br wire open or shorted to ground, or poor (ⓐ),
 (ⓑ) or (ⓒ) connection.

If wire and connection are OK, Intermittent trouble or faulty
 ECM.

Recheck each terminal and wire harness for open circuit
 and poor connection.

→ Replace the ECM with a new one,
 and inspect it again.

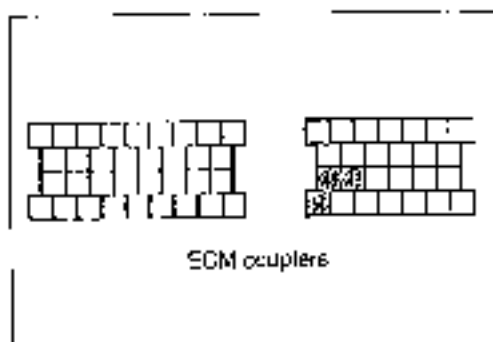
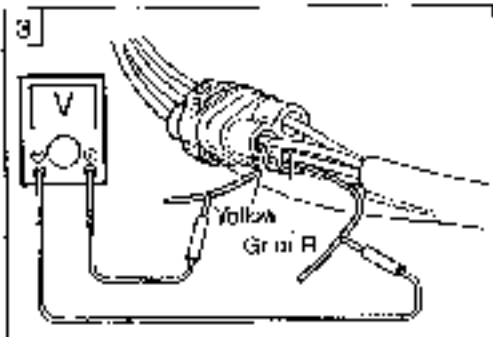

"C15" ECT SENSOR CIRCUIT MALFUNCTION

DETECTED CONDITION	POSSIBLE CAUSE
Output voltage low or high. ($0.15 \text{ V} \leq \text{Sensor voltage} < 4.65 \text{ V}$) without the above range.	<ul style="list-style-type: none"> ECT sensor circuit open or short. ECT sensor malfunction. ECM malfunction.

INSPECTION

- Remove the maintenance lid. (P. 9-13)

- 1 Turn the ignition switch OFF.
Check the ECT sensor coupler for loose or poor contacts.
If OK, then measure the ECT sensor voltage at the wire side coupler.
Disconnect the coupler and turn the ignition switch ON.
Measure the voltage between B/BI wire terminal and ground.
If OK, then measure the voltage between B/BI wire terminal and B/Br wire terminal.

DATA ECT sensor voltage: 4.5 – 5.5 V
(⊕B/BI – ⊖Ground)
(⊕B/BI – ⊖B/Br)

TOOL 09900-25008: Multi circuit tester

TESTER Tester knob indication: Voltage (V)

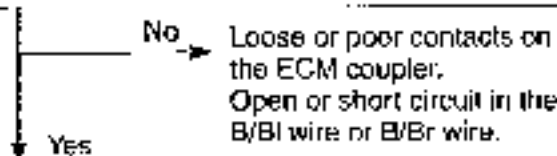

- 2 Turn the ignition switch OFF.
Measure the ECT sensor resistance.

DATA ECT sensor resistance:
Approx. 2.45 kΩ at 20 °C (68 °F) (Terminal – Terminal)

TOOL 09900-25008: Multi circuit tester

TESTER Tester knob indication: Resistance (Ω)

Refer to page B-13 for details.



B/BI or B/Br wire open or shorted to ground, or poor Ⓢ or Ⓣ connection.

If wire and connection are OK, intermittent trouble or faulty ECM.

Recheck each terminal and wire harness for open circuit and poor connection.

Replace the ECM with a new one, and inspect it again.

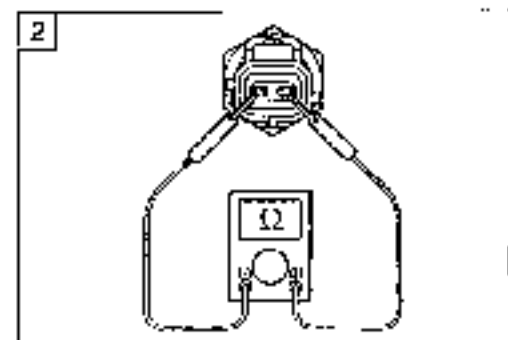
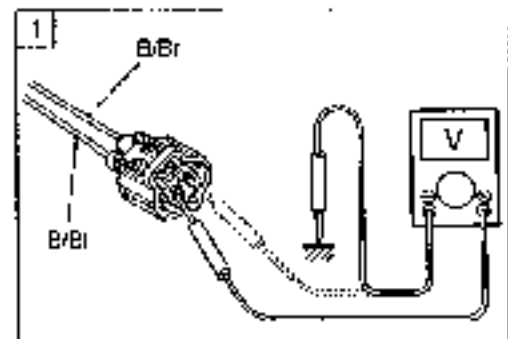
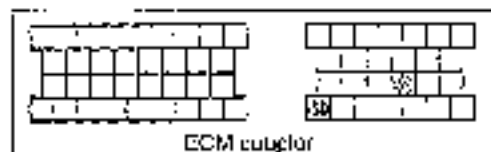

Engine Coolant Temp.	Resistance
20 °C (68 °F)	Approx. 2.45 kΩ
50 °C (112 °F)	Approx. 0.811 kΩ
80 °C (176 °F)	Approx. 0.318 kΩ
110 °C (230 °F)	Approx. 0.142 kΩ

"C16" SPEED SENSOR CIRCUIT MALFUNCTION

DETECTED CONDITION	POSSIBLE CAUSE
The speed sensor signal is not input to FCM for more than 3 sec. during vehicle deceleration.	<ul style="list-style-type: none"> Speed sensor circuit open or short. Metal particles or foreign material being attached on the speed sensor. Speed sensor malfunction. FCM malfunction.

INSPECTION

- Remove the foot board. (C-7-9-18)

- 1 Turn the ignition switch OFF.
Check the speed sensor lead wire coupler (1) for loose or poor contacts.
If OK, then measure the speed sensor input voltage.
Insert the copper wires to the lead wire coupler.
Turn the ignition switch ON.
Measure the speed sensor input voltage at the coupler between (+)O/R and (-)B/W wire.

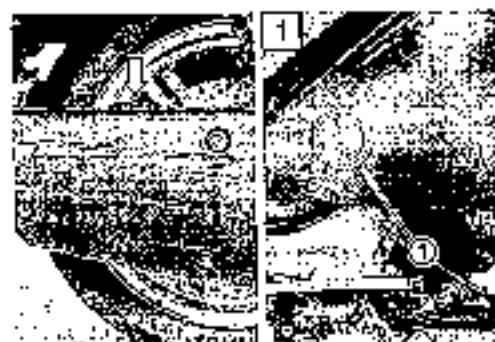

DATA Speed sensor input voltage: More than 7 V
(+)O/R - (-)B/W

TOOL 09900-25008: Multi circuit tester

TESTER Tester knob indication: Voltage (---)

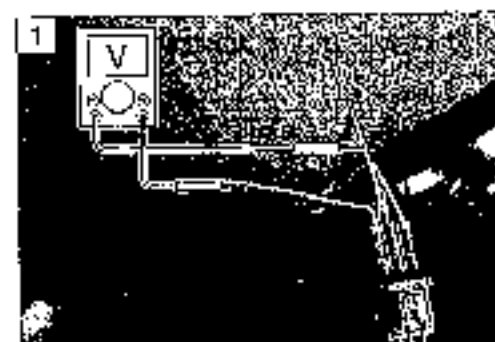

NG → Loose or poor contacts on the ECM couplers.
Open or short circuit in the O/R wire or B/W wire.

OK ↓

- 2 Remove the speed sensor.
Clean away metal particles or foreign material.



Next page

- 3 Check the speed sensor output voltage.
 Insert the copper wires to the lead wire coupler. (White – Black/White)
 Turn the ignition switch ON.
 Check that the voltage varies when a screwdriver is brought close to the pick-up face of the speed sensor.

 09900-2500B: Multi circuit tester

 Tester knob indication: Voltage (---)

NG → Short circuit in the lead wire.
 Replace the speed sensor with a new one.

OK
 Recheck ECM coupler for loose or poor contacts.
 Replace ECM with a new one and inspect it again.

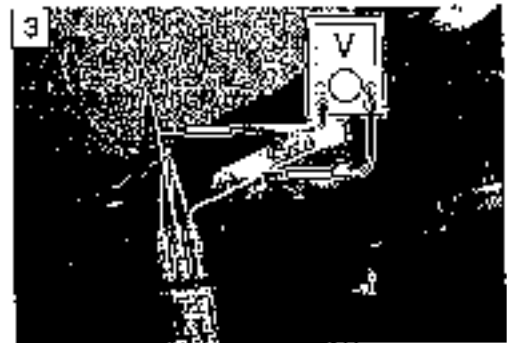

"C21" IAT SENSOR CIRCUIT MALFUNCTION

DETECTED CONDITION	POSSIBLE CAUSE
Output voltage low or high. ($0.15 \text{ V} \leq \text{Sensor voltage} < 4.85 \text{ V}$) without the above range.	<ul style="list-style-type: none"> IAT sensor circuit open or short. IAT sensor malfunction. ECM malfunction.

INSPECTION

- Remove the front box. (C-79-1B)

- Turn the ignition switch OFF.
Check the IAT sensor coupler for loose or poor contacts.
If OK, then measure the IAT sensor voltage at the wire side coupler.
Disconnect the coupler and turn the ignition switch ON.
Measure the voltage between Dg wire terminal and ground.
If OK, then measure the voltage between Dg wire terminal and B/Br wire terminal.

DATA IAT sensor voltage: 4.5 – 5.6 V
 (⊕Dg – ⊖Ground)
 (⊕Dg – ⊖B/Br)

TOOL 09900-25008: Multi circuit tester

TESTER Tester knob Indication: Voltage (V)

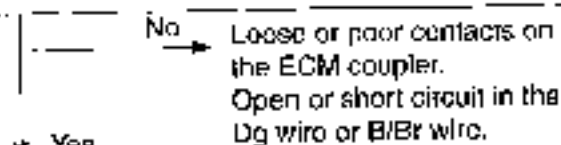

Yes

- Turn the ignition switch OFF.
Measure the IAT sensor resistance.

DATA IAT sensor resistance:
Approx. 2.45 kΩ at 20 °C (68 °F) (Terminal – Terminal)

TOOL 09900-25008: Multi circuit tester

TESTER Tester knob Indication: Resistance (Ω)



Yes

Dg or B/Br wire open or shorted to ground, or poor ⊕ or ⊖ connection.

If wire and connection are OK, Intermittent trouble or faulty ECM.

Recheck each terminal and wire harness for open circuit and poor connection.

Replace the ECM with a new one, and inspect it again.

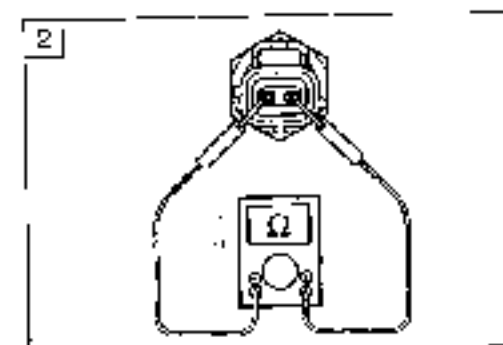
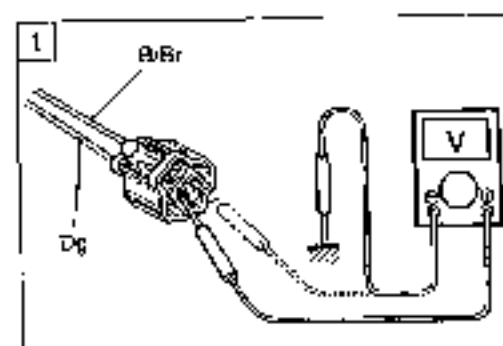
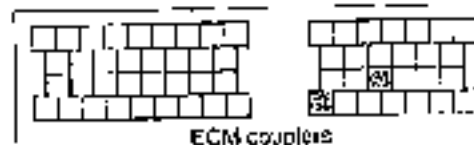

Intake Air Temp.	Resistance
20 °C (68 °F)	Approx. 2.45 kΩ
50 °C (112 °F)	Approx. 0.008 kΩ
80 °C (176 °F)	Approx. 0.322 kΩ
110 °C (230 °F)	Approx. 0.148 kΩ

NOTE:

IAT sensor resistance measurement method is the same way as that of the ECT sensor. Refer to page 8-13 for details.

"C22" AP SENSOR CIRCUIT MALFUNCTION

DETECTED CONDITION	POSSIBLE CAUSE
Output voltage low or high. ($0.50\text{ V} \leq \text{Sensor voltage} < 4.85\text{ V}$) without the above range. NOTE: <i>Note that atmospheric pressure varies depending on weather conditions as well as altitude. Take that into consideration when inspecting voltage.</i>	<ul style="list-style-type: none"> • Clogged air passage with dust • AP sensor circuit open or short. • AP sensor malfunction. • ECM malfunction.

INSPECTION

- Remove the front box. (C-9-18)

- 1 Turn the ignition switch OFF.
 Check the AP sensor coupler for loose or poor contacts.
 If OK, then measure the AP sensor input voltage.
 Turn the ignition switch ON.
 Disconnect the AP sensor coupler.
 Measure the voltage between Red wire and ground.
 If OK, then measure the voltage between Red wire and B/Br wire.

DATA AP sensor input voltage: 4.5 - 5.5 V

(⊕Red - ⊖Ground)
 (⊕Red - ⊖B/Br)

TEST 09900-25008: Multi circuit tester

TEST Tester knob indication: Voltage (V)

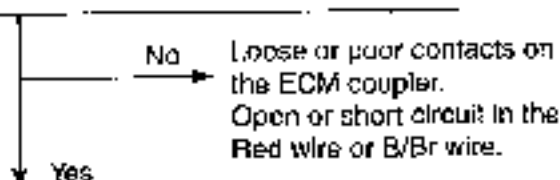

- 2 Connect the AP sensor coupler.
 Insert the copper wires to the lead wire coupler.
 Turn the ignition switch ON.
 Measure the AP sensor output voltage at the wire side coupler between G/Y and B/Br wires.

DATA AP sensor output voltage: Approx. 3.6 V
 at 760 mmHg (100 kPa)
 (⊕G/Y - ⊖B/Br)

TEST 09900-25008: Multi circuit tester

TEST Tester knob indication: Voltage (V)

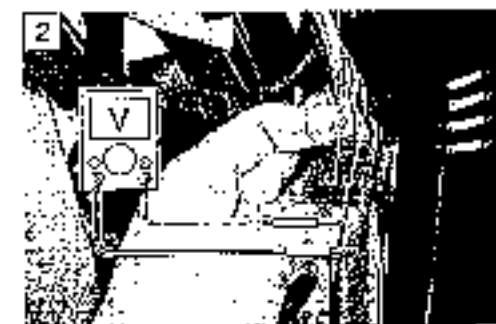
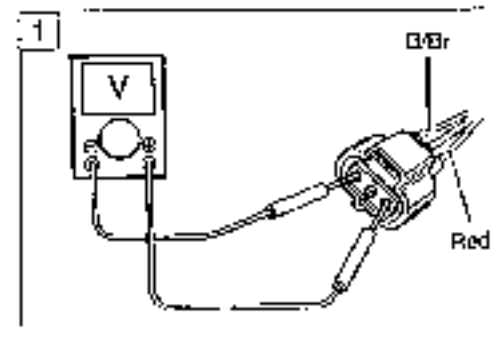
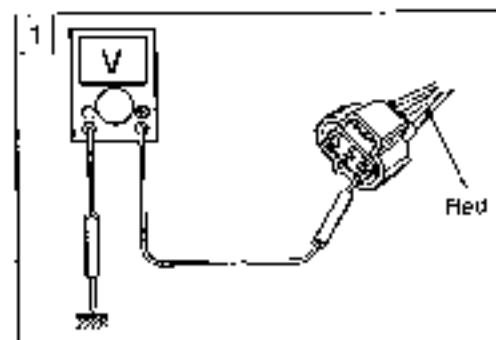
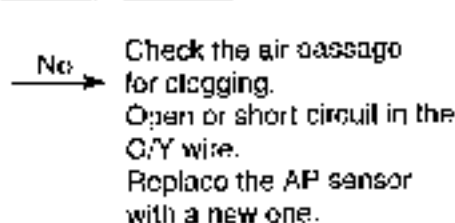



- 3 Remove the AP sensor.
Connect the vacuum pump gauge to the air passage port of the AP sensor.
Arrange 3 new 1.5 V batteries in series (check that total voltage is 4.5 – 5.0 V) and connect (–) terminal to the ground terminal and (+) terminal to the Vcc terminal.
Check the voltage between PA and ground. Also, check if voltage reduces when vacuum is applied up to 40 cmHg by using vacuum pump gauge. (See table below.)

 09917-47010: Vacuum pump gauge
09900-25008: Multi circuit tester

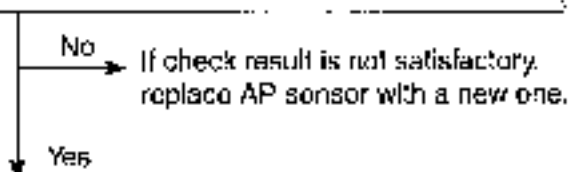
 Tester knob indication: Voltage (—)



Red, G/Y or B/Bt wire open or shorted to ground, or poor ,  or  connection.

If wire and connection are OK, intermittent trouble or faulty ECM.

Recheck each terminal and wire harness for open circuit and poor connection.

→ Replace the ECM with a new one, and inspect it again.

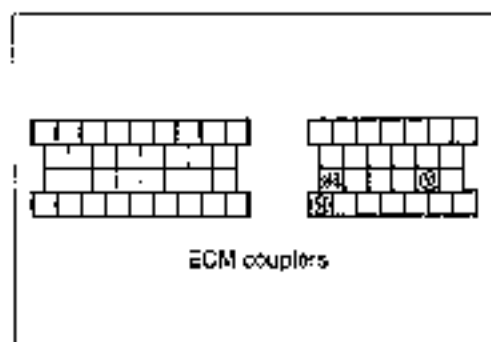
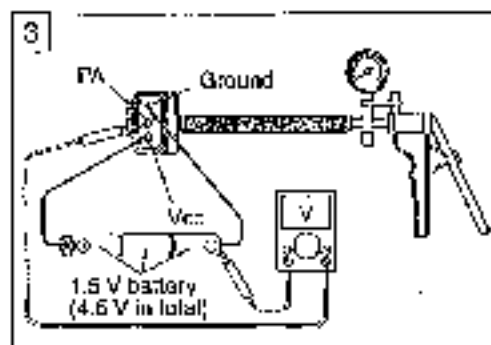

Output voltage (Vcc voltage 4.5 – 5.0 V, ambient temp. 20 – 30 °C, 68 – 86 °F)

ALTITUDE (Reference)		ATMOSPHERIC PRESSURE		OUTPUT VOLTAGE (V)
(ft)	(m)	(mmHg)	kPa	
0	0	760	100	3.1 – 3.6
2 000	610	707	94	
2 001	611	707	94	2.8 – 3.4
5 000	1 524	634	85	
5 001	1 525	634	85	2.6 – 3.1
8 000	2 438	567	76	
8 001	2 439	567	76	2.4 – 2.9
10 000	3 048	528	70	

"C23" TO SENSOR CIRCUIT MALFUNCTION

DETECTED CONDITION	POSSIBLE CAUSE
Output voltage low or high ($0.20 \text{ V} \leq \text{Sensor voltage} < 4.80 \text{ V}$) without the above range.	<ul style="list-style-type: none"> • TO sensor circuit open or short. • TO sensor malfunction. • ECM malfunction.

INSPECTION

- Remove the front panel. (C-9-B)

- 1 Turn the Ignition switch OFF.
Check the TO sensor coupler for loose or poor contacts.
If OK, then measure the TO sensor resistance.
Disconnect the TO sensor coupler.
Measure the resistance between Red and B/Br wire terminals.

DATA TO sensor resistance: 19.1 – 19.7 k Ω (Red – B/Br)

TOOL 09900-25008: Multi circuit tester

TESTER Tester knob indication: Resistance (Ω)

No → Replace the TO sensor with a new one.

Yes →

- 2 Connect the TO sensor coupler.
Insert the copper wires to the lead wire coupler.
Turn the Ignition switch ON.
Measure the voltage at the wire side coupler between B and B/Br wires.

DATA TO sensor voltage: Less than 1.4 V (B – B/Br)

Also, measure the voltage when leaning of the motorcycle.
Dismount the TO sensor from its bracket and measure the voltage when it is leaned more than 65°, left and right, from the horizontal level.

DATA TO sensor voltage: More than 3.7 V (B – B/Br)

TOOL 09900-25008: Multi circuit tester

TESTER Tester knob indication: Voltage (---)

No → Loose or poor contacts on the ECM coupler.
Open or short circuit.
Replace the TO sensor with a new one.

Yes →

Red, B or B/Br wire open or shorted to ground, or poor \oplus , \ominus or \oplus connection.
If wire and connection are OK, intermittent trouble or faulty ECM.
Reread each terminal and wire harness for open circuit and poor connection.

Replace the ECM with a new one, and inspect it again.

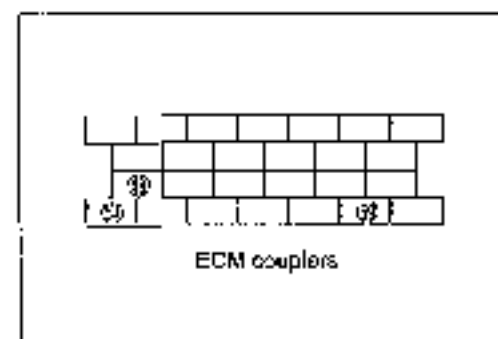
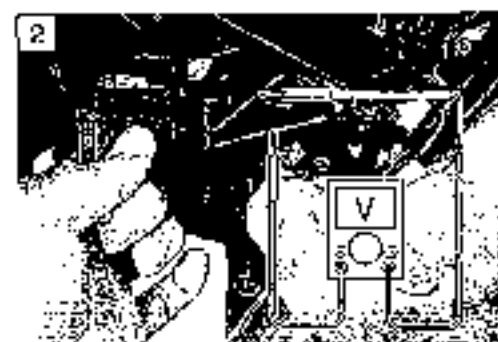
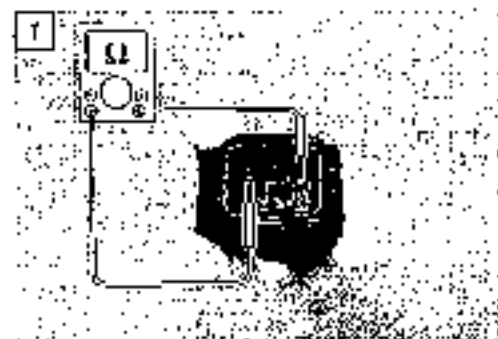

"C24" or "C25" IGNITION SYSTEM MALFUNCTION

*Refer to the IGNITION SYSTEM for details. (C-7-10-18)

"C32" or "C33" FUEL INJECTOR CIRCUIT MALFUNCTION

DETECTED CONDITION	POSSIBLE CAUSE
CKP signal is produced but fuel injector signal is interrupted continuous by 4 times or more.	<ul style="list-style-type: none"> • Injector circuit open or short. • Injector malfunction. • ECM malfunction.

INSPECTION

- Remove the front box. (C-7-9-18)

1 Turn the ignition switch OFF.
Check the injector coupler for loose or poor contacts.
If OK, then measure the injector resistance.
Disconnect the coupler and measure the resistance between terminals.

DATA Injector resistance: 11 – 13 Ω at 20 °C (68 °F)
(Terminal – Terminal)

If OK, then check the continuity between each terminal and ground.

DATA Injector continuity: ∞ Ω (Infinity)
(Terminal – Ground)

TOOL 09900-25008: Multi circuit tester

TESTER Tester knob indication: Resistance (Ω)

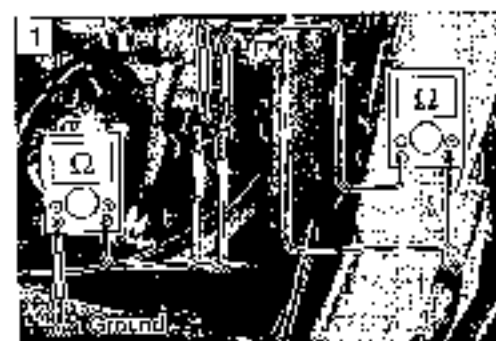

No → Replace the injector with a new one. (C-7-17, 21)

Yes

2 Turn the ignition switch ON.
Measure the injector voltage between Y/R wire and ground.

DATA Injector voltage: Battery voltage
(Y/R – Ground)

NOTE:
Injector voltage can be detected only 3 seconds after ignition switch is turned ON.

TOOL 09900-25008: Multi circuit tester

TESTER Tester knob indication: Voltage (V)



No → Open circuit in the Yellow/Red wire.

Yes

Gr/W, Gr/B or Y/R wire open or shorted to ground, or poor (4), (5) or (6) connection.

If wire and connection are OK, intermittent trouble or faulty ECM.

Recheck each terminal and wire harness for open circuit and poor connection.

→ Replace the ECM with a new one, and inspect it again.

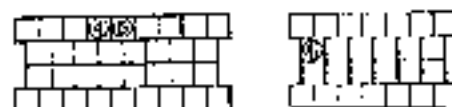

ECM couplers

"C40" IAC VALVE CIRCUIT MALFUNCTION

*Refer to the IAC VALVE INSPECTION for details. (C77-20)

**"C41" FP RELAY CIRCUIT MALFUNCTION**

DETECTED CONDITION	POSSIBLE CAUSE
No voltage is applied to fuel pump although fuel pump relay is turned ON, or voltage is applied to fuel pump although fuel pump relay is turned OFF.	<ul style="list-style-type: none"> Fuel pump relay circuit open or short. Fuel pump relay malfunction. ECM malfunction.

INSPECTION

- Remove the front box. (C79-18)

- 1 Turn the ignition switch OFF.
Check the FP relay coupler for loose or poor contacts.
If OK, then check the insulation and continuity. Refer to page 10-28 for details.

No → Replace the FP relay with a new one.

Yes

Y/G or O/W wire open or shorted to ground, or poor (Q) or (R) connection.

If wire and connection are OK, intermittent trouble or faulty ECM.

Recheck each terminal and wire harness for open circuit and poor connection.

→ Replace the ECM with a new one, and inspect it again.



ECM couplers

"C42" IG SWITCH CIRCUIT MALFUNCTION

*Refer to the IGNITION SWITCH INSPECTION for details.

- Remove the leg shield. (C7-10-35)



"C44" HO2 SENSOR (HO2S) CIRCUIT MALFUNCTION (E-02, 19)

DETECTED CONDITION	POSSIBLE CAUSE
During O2 feedback control, O2 sensor generating voltage is as follows (Sensor voltage < 0.45) (Without the above range.) The heater circuit disconnection is detected during engine operation, or no electrical power is supplied from battery.	<ul style="list-style-type: none"> • HO2 sensor or its circuit open or short. • Fuel system malfunction • ECM malfunction.

INSPECTION

- Remove the foot board. (C-7-18)

1 Turn the ignition switch OFF.

Check the HO2 sensor coupler for loose or poor contacts. Insert the copper wires to the HO2 sensor lead wire coupler. Warm up the engine enough.

Measure the HO2 sensor output voltage at the coupler (between Black and Gray wires) when idling condition.

Also, measure the HO2 sensor output voltage while holding the engine speed at 3 000 r/min.

DATA HO2 sensor output voltage at idle speed:

Less than 0.4 V (⊕ B - ⊖ Gr)

HO2 sensor output voltage at 3 000 r/min:

More than 0.6 V (⊕ B - ⊖ Gr)

 09900-25008: Multi circuit tester

 Tester knob indication: Voltage (—)

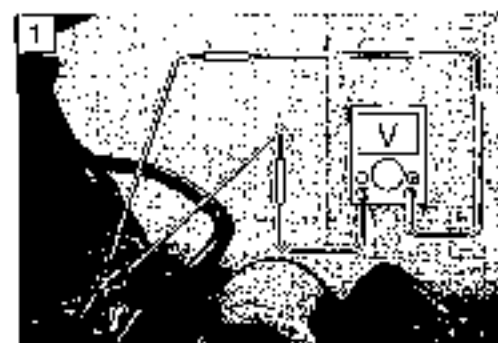
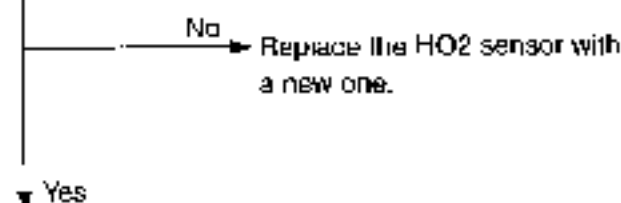

- 2 Turn the Ignition switch OFF.
Turn the Ignition switch ON and measure the heater voltage between Orange/White wire (ECM side) and ground.
If the tester voltage indicates the battery voltage for few seconds, it is good condition.

DATA Heater voltage: Battery voltage
(O/W - Ground)

NOTE:

Battery voltage can be detected only during few seconds after ignition switch is turned ON

TOOLS 09900-25008: Multi circuit tester

TESTER Tester knob indication: Voltage (-.-)

Yes
No → Replace the HO2 sensor with a new one.

- 3 Turn the Ignition switch OFF.
Disconnect the HO2 sensor coupler.
Check the resistance between the terminals (White - White) of the HO2 sensor.

DATA HO2 heater resistance: 4 - 5 Ω (at 23 °C/73.4 °F)
(White - White)

NOTE:

- Temperature of the sensor affects resistance value largely.
- Make sure that the sensor heater is at correct temperature.

TOOLS 09900-25008: Multi circuit tester set

TESTER Tester knob indication: Resistance (Ω)

Yes
No → Replace the HO2 sensor with a new one.

Black, Gray or White wire open or shorted to ground, or poor Ⓐ, Ⓑ, Ⓒ or Ⓓ connection.

If wire and connection are OK, intermittent trouble or faulty ECM.

Recheck each terminal and wire harness for open circuit and poor connection.

→ Check the fuel supply system, if the system is OK, replace the ECM with a new one, and inspect it again.

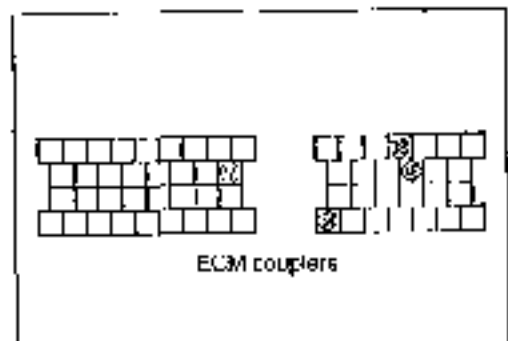
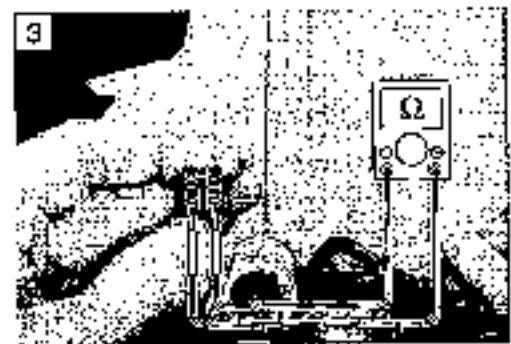
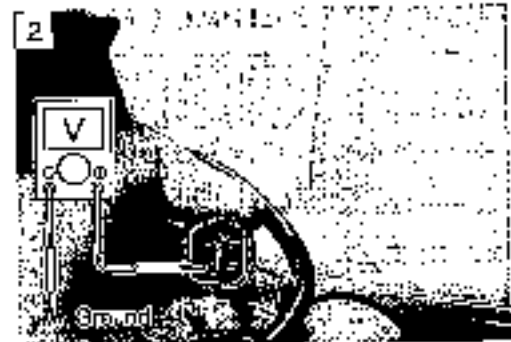

"C50" CVT SERIAL COMMUNICATION CIRCUIT MALFUNCTION

DETECTED CONDITION	POSSIBLE CAUSE
No signal is supplied from CVT control unit to ECM for more than 5 sec. after starting the engine.	<ul style="list-style-type: none"> • "C58" circuit open or short. • CVT control unit malfunction. • ECM malfunction.

INSPECTION

- Remove the front panel. (☐ 9-B)

1 Turn the ignition switch OFF.
 Check the ECM coupler and CVT control unit coupler for loose or poor contacts.
 If OK, check for existence of CVT serial communication signal.
 Insert the copper wire to the lead wire coupler at the CVT control unit side. Measure the communication signal at the Dark brown wire and Ground.

NOTE:
 Do not need to disconnect any CVT control unit couplers.

DATA CVT serial communication signal:
 More than 7 V
 (⊕Dbr - ⊖Ground)

09900-25008: Multi circuit tester
Tester knob indication: Voltage (---)

NG → Loose or poor contacts on the CVT control unit coupler. Replace the CVT control unit with a new one.

OK → Replace the ECM with a new one, and inspect it again.

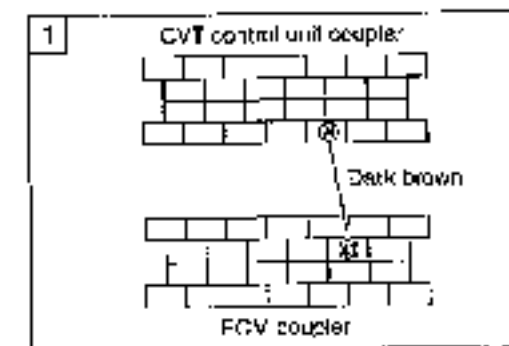
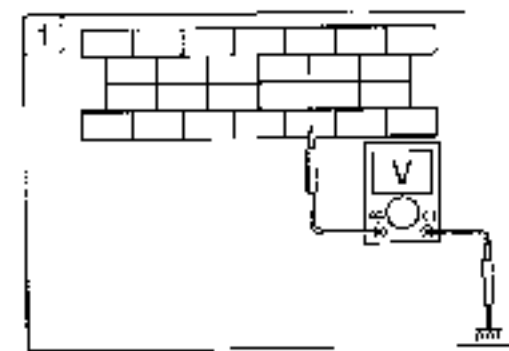
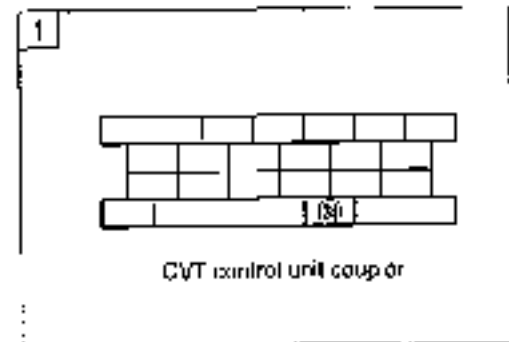

"C51" CVT MOTOR CIRCUIT MALFUNCTION

DETECTED CONDITION	POSSIBLE CAUSE
CVT motor operating voltage is not supplied from CVT control unit.	<ul style="list-style-type: none"> • CVT motor circuit open or short. • CVT motor malfunction. • CVT control unit malfunction.

INSPECTION

- Remove the foot board. (C79-18)
- Place the motorcycle on the center stand and put the side stand in.

- 1 Turn the ignition switch OFF.
Check the CVT motor coupler ① for loose or poor contacts.
If OK, then measure the CVT motor operating voltage.
Insert the copper wires to the coupler ①.
Remove the center stand switch ②.
Start the engine and shift to Automatic mode.
Check that there is a change of motor operating voltage as the engine speed is raised.

 09900-25008: Multi circuit tester

 Tester knob indication: Voltage (V)

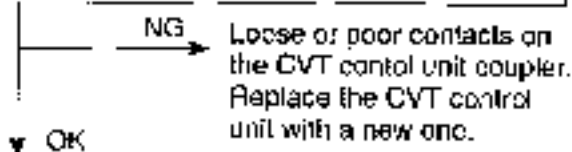

- 2 Disconnect the CVT motor coupler.
Check the continuity between Red wire – ground and B wire – ground.

DATA CVT motor continuity: $\infty \Omega$ (Infinity)
(Red wire – Ground)
(Black wire – Ground)

If OK, then measure the CVT motor resistance at the coupler.

DATA CVT motor resistance: Less than 0.8Ω

 09900-25008: Multi circuit tester

 Tester knob indication: Resistance (Ω)



Next page

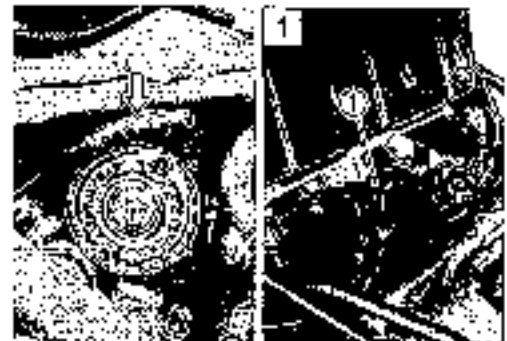

- 3 Remove the CVT motor.
Apply 12 volts to the terminals of the CVT motor lead wire coupler.
Check the CVT motor movement.
Then, swap the wires supplied 12 volts and check the movement.
Check the CVT motor both way movements.

NG → Replace the CVT motor.

OK

Replace the ECM with a new one, and inspect it again.



"C52" CVT PULLEY POSITION SENSOR (PPS) CIRCUIT MALFUNCTION

DETECTED CONDITION	POSSIBLE CAUSE
PPS voltage low or high. ($0.06\text{ V} \leq \text{Sensor voltage} \leq 5.04\text{ V}$) without the above range.	<ul style="list-style-type: none"> • PPS circuit open or short. • PPS malfunction. • CVT control unit malfunction.

INSPECTION

- Remove the foot board. (☞ 9-18)
- Place the motorcycle on the center stand and put the side stand in

- 1** Turn the ignition switch OFF.
Check the PPS coupler (1) for loose or poor contacts.
If OK, then measure the PPS input voltage.
Insert the copper wires to the coupler.
Turn the ignition switch ON and measure the PPS input voltage.

DATA PPS input voltage: 4.5 - 5.5 V (⊕ Lb/O or R - ⊖ B)

BOOK 09900-25008: Multi circuit tester

V Tester knob indication: Voltage (V)

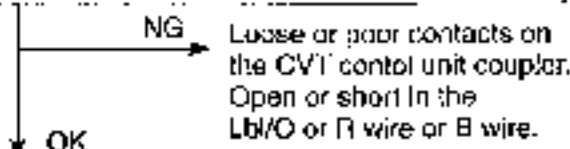

- 2** Turn the ignition switch OFF.
Measure the PPS output voltage.
Insert the copper wires to the PPS coupler.
Remove the center stand switch (2).
Start the engine and shift to Manual mode.
Check for PPS output voltage at revolution each for 1st, 3rd and 5th as shown below.

DATA PPS output voltage: (⊕ Lb/Y or BI - ⊖ B)

1st-Idle rpm: Approx. 3.3 V

3rd-3000 rpm: Approx. 1.3 V

5th-3000 rpm: Approx. 0.6 V

BOOK 09900-25008: Multi circuit tester

V Tester knob indication: Voltage (V)

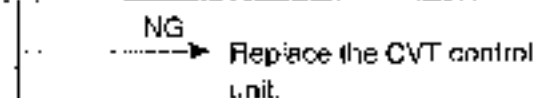

Next page



3 Turn the ignition switch OFF.
Remove the PPS.
Measure the resistance each when the sensor is compressed and extended to the maximum between Lb/Y or Bl wire and B wire terminals.

DATA PPS resistance : (Lb/Y or Bl - B)
Compressed : 1.9 - 2.3 kΩ
Extended : 0.2 - 1.0 kΩ

Tool 09900-25008: Multi circuit tester

Tester knob indication: Resistance (Ω)

Check the PPS smooth movement.

NG → Replace the PPS with a new one.

OK

Ⓐ, Ⓑ or Ⓒ wire open or shorted to ground, or poor connection.

If wire and connection are OK, Intermittent trouble or faulty ECM.

Recheck each terminal and wire harness for open circuit and poor connection.

Replace the ECM with a new one, and inspect it again.

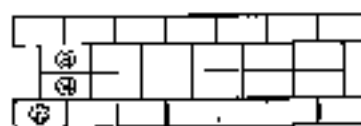
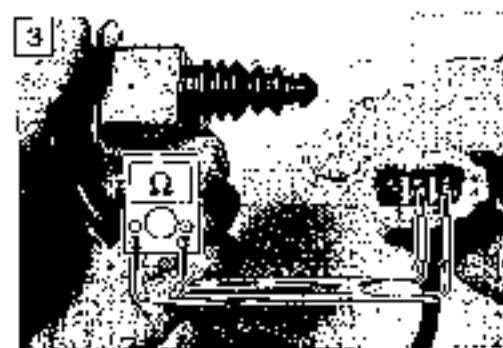
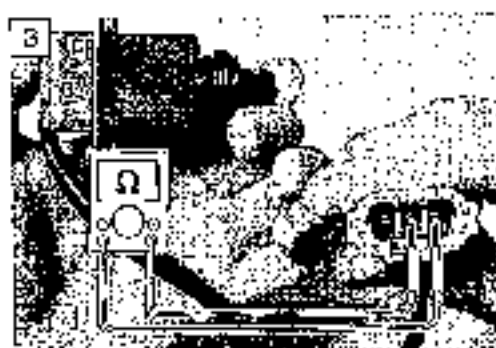

CVT cent of unc coupler

"C53" CVT SPEED SENSOR CIRCUIT MALFUNCTION

DETECTED CONDITION	POSSIBLE CAUSE
The speed sensor signal is not input to CVT control unit for more than 3 sec. during vehicles running.	<ul style="list-style-type: none"> Speed sensor circuit open or short. Metal particles or foreign material being attached on the speed sensor. Speed sensor malfunction. CVT control unit malfunction.

INSPECTION

- Remove the foot board. (☞9-18)

- 1 Turn the ignition switch OFF.
Check the speed sensor lead wire coupler ① for loose or poor contacts.
If OK, then measure the speed sensor input voltage.
Insert the copper wires to the lead wire coupler.
Turn the ignition switch ON.
Measure the speed sensor input voltage at the coupler between ⊕O/R and ⊖B/W wire.

DATA Speed sensor input voltage: More than 7 V
(⊕O/R - ⊖B/W)

TOOL 09900-25006: Multi circuit tester

TESTER Tester knob indication: Voltage (---)

NG → Loose or poor contacts on the CVT control unit couplers.
Open or short circuit in the O/R wire or B/W wire.

OK

- 2 Remove the speed sensor.
Clean away metal particles or foreign material.

Next page

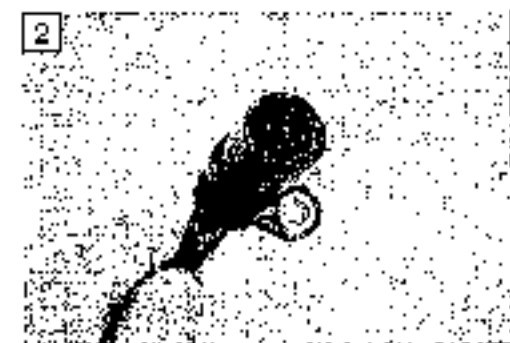
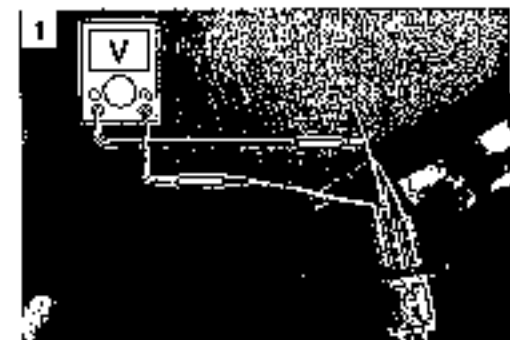

- 3 Check the speed sensor output voltage.
 Insert the copper wires to the load wire coupler. (White – Black/White)
 Turn the ignition switch ON.
 Check that the voltage varies when a screwdriver is brought close to the pick-up face of the speed sensor.

 09900-25008: Multi circuit tester

 Tester knob indication: Voltage (-:)

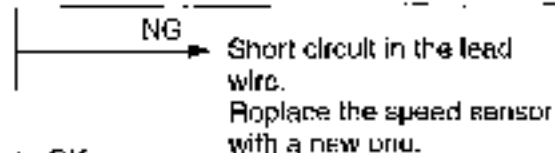

↓ OK

Recheck the CVT control unit coupler for loose or poor contacts.
 Replace the CVT control unit with a new one and inspect it again.

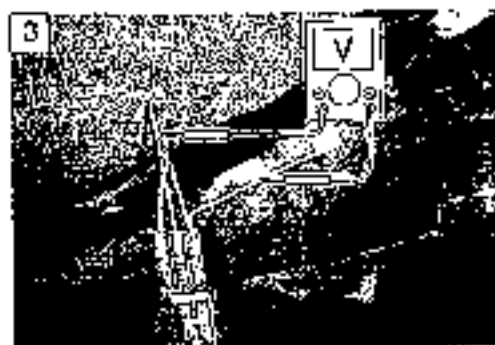

"C54" CVT SECONDARY PULLEY REVOLUTION SENSOR CIRCUIT MALFUNCTION

DETECTED CONDITION	POSSIBLE CAUSE
The CVT secondary pulley revolution signal is not input to CVT control unit at speed of 20 km or higher.	<ul style="list-style-type: none"> • Sensor circuit open or short. • Metal particles or foreign material being attached on the speed sensor. • Revolution sensor malfunction. • CVT control unit malfunction.

INSPECTION

- Remove the foot board. (☞ 9-18)
- Place the motorcycle on the center stand and put the side stand in.

- 1 Turn the ignition switch OFF.
Check the CVT secondary pulley revolution sensor coupler ① for loose or poor contacts.
If OK, then measure the revolution sensor resistance.
Disconnect the revolution sensor coupler and measure the resistance between Yellow and White wire terminals.

DATA CVT secondary pulley revolution sensor resistance: 400 – 600 Ω
(Yellow – White)

09900-25008: Multi circuit tester

Tester knob Indication: Resistance (Ω)

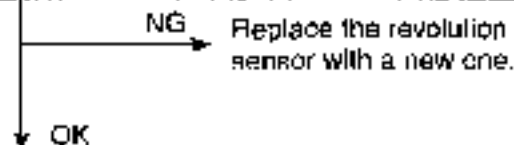

- 2 Remove the revolution sensor lead wire coupler.
Start the engine and measure the revolution sensor peak voltage at idle speed

DATA Revolution sensor peak voltage : More than 5.0 V (at idle speed)
(⊕Yellow – ⊖White)

Repeat the above procedure a few times and measure the highest peak voltage.

09900-25008: Multi circuit tester

Tester knob Indication: Voltage (V)

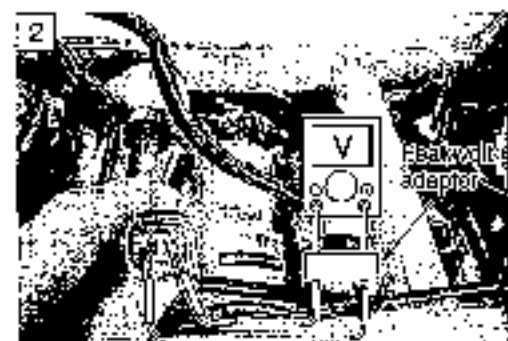
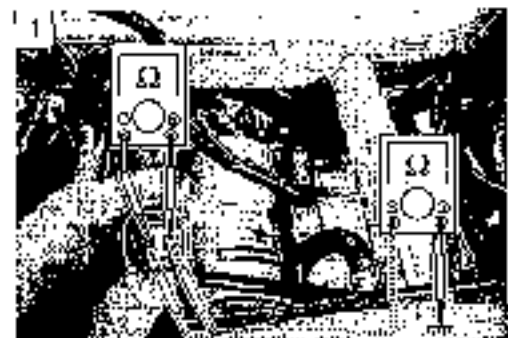
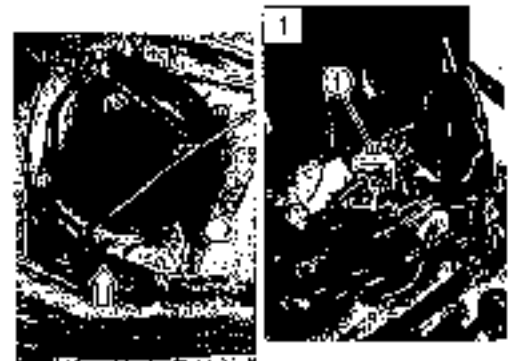
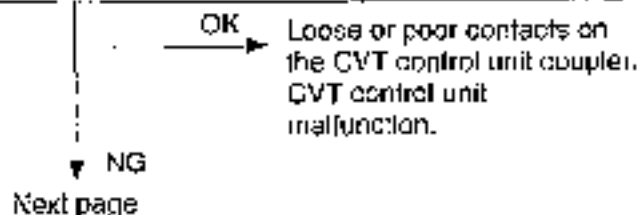

- 3 Remove the CVT assembly. (☐ 5-2)
Remove the CVT secondary pulley revolution sensor (2)
Clean away metal particles or foreign material.



If "C54" code is indicated, replace the CVT control unit.



"C55" CVT ENGINE REVOLUTION SIGNAL CIRCUIT MALFUNCTION

DETECTED CONDITION	POSSIBLE CAUSE
The CVT engine revolution signal is not input to CVT control unit from ECM at speed of 20 km or higher.	<ul style="list-style-type: none"> • Lead wire open or short. • ECM malfunction. • CVT control unit malfunction.

INSPECTION

- Remove the front panel. (C-9-8)
- Place the motorcycle on the center stand and put the slide stand in.

- 1 Check the ECM and CVT control unit couplers for loose or poor contacts.
If OK, check the CVT engine revolution signal.
Insert the copper wire to the ③ (Br/W) wire of the CVT control unit coupler.
Start the engine and measure the signal voltage between (+)Br/W (③) wire and (-)Ground.

NOTE:

Do not need to disconnect any couplers.

DATA CVT engine revolution signal: Approx. 2.5 V
(+Br/W - (-)Ground)

09900-25008: Multi circuit tester

Tester knob indication: Voltage (-)

NG → Short circuit in the Br/W lead wire.
Loose or poor contacts.
ECM malfunction.

OK

Loose or poor contacts on the CVT control unit couplers.
CVT control unit malfunction.

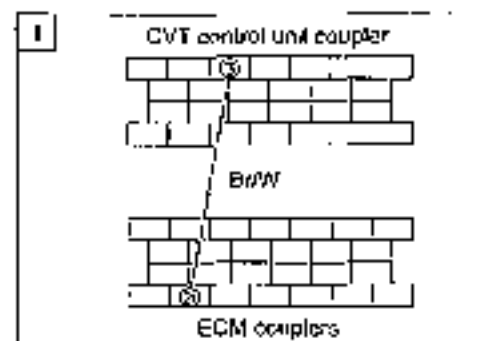
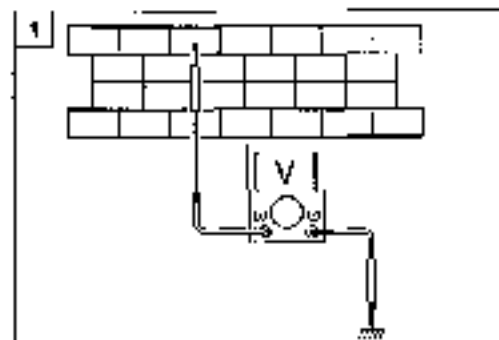
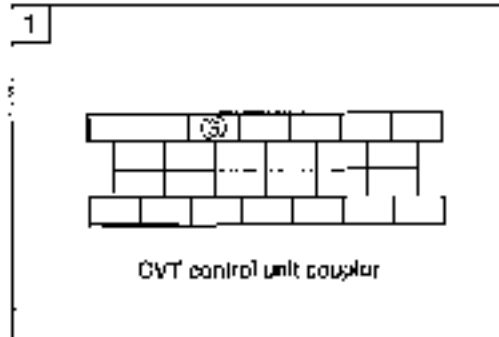

"C56" CVT THROTTLE POSITION SIGNAL CIRCUIT MALFUNCTION

DETECTED CONDITION	POSSIBLE CAUSE
The CVT throttle position signal is not input to CVT control unit from ECM for more than 5 sec. after ignition switch turns ON.	<ul style="list-style-type: none"> • Lead wire open or short. • ECM malfunction. • CVT control unit malfunction.

INSPECTION

- Remove the front panel. (C-7-8)

- 1 Check the ECM and CVT control unit couplers for loose or poor contacts.
If OK, check the CVT throttle signal.
Insert the copper wire to the ⓇBlack/Red (Ⓢ) wire of the CVT control unit coupler.
Turn the ignition switch ON and measure the signal voltage by turning the throttle grip.

NOTE:

Do not need to disconnect any couplers.

DATA CVT throttle signal

Throttle valve is closed: Approx. 3.6 V

Throttle valve is open: Approx. 1.7 V

 08900-25008: Multi circuit tester

 Tester knob indication: Voltage (V)

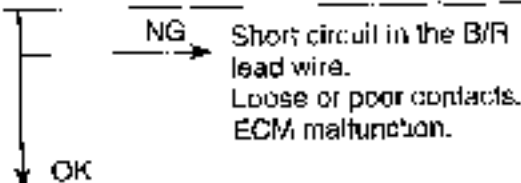

Loose or poor contacts on the CVT control unit couplers.
CVT control unit malfunction.

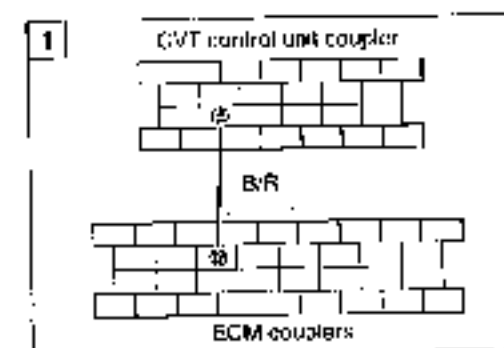
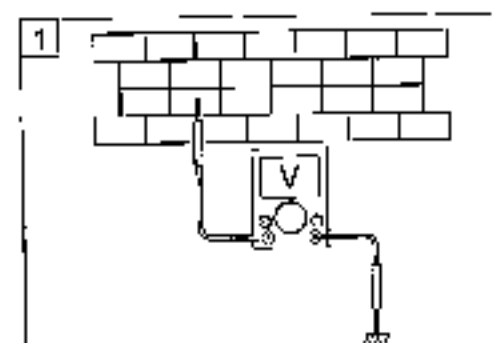
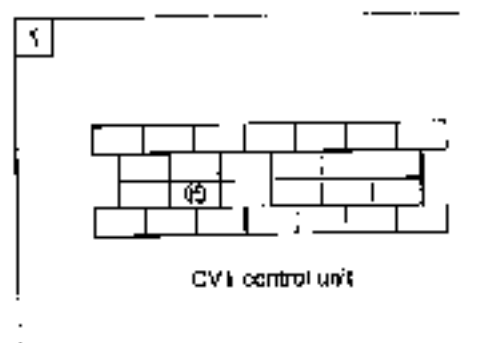

"C58" CVT REDUCTION RATIO DISAGREEMENT

DETECTED CONDITION	POSSIBLE CAUSE
The revolution ratio detected by CVT pulley position sensor (PPS) disagrees with actual revolution ratio for more than 4 sec.	PPS is stuck immovable. Foreign substance such as water, oil or metal particle has entered CVT assembly.

INSPECTION

- 1 Turn the ignition switch OFF so that the malfunction code is reset.

Warm up the engine sufficiently and test drive to see if "C58" code appears.

If "C58" appears during test running, proceed to stage 2.

OK → Transitory slipping due to entry of water, oil, metal particle, etc.
If problem does not persist, complete the inspection.

"C58" is indicated.

- 2 Inspect the PPS ①
Remove the foot board. (C-9-18)
Remove the PPS ① and check the PPS for smooth movement.

NG → Replace the PPS with a new one.

OK

- 3 Inspect the CVT assembly.
Check for existence of water, oil or metal particle, etc. (C-5-5)
If anything is wrong, replace the defective parts.

OK → Complete the inspection

NG

Replace the CVT control unit (CVT control module) with a new one and inspect it again.

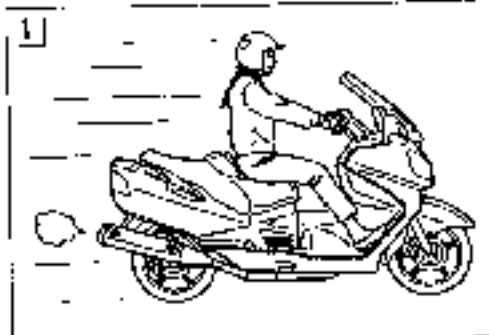

SENSORS

THROTTLE POSITION SENSOR (TPS) SETTING

- After all adjustments are completed, check or adjust the TPS setting condition.

TPS SETTING PROCEDURE (☞ 6-20)



CKP SENSOR

The signal rotor is installed on the exhaust camshaft, and the camshaft position sensor (Pick-up coil) is installed on the cylinder head cover. (☞ 6-27)



CKP SENSOR

The signal rotor is mounted on the generator rotor, and the crankshaft position sensor (Pick-up coil) is installed above the rotor. (☞ 6-28)



IAP SENSOR

The Intake air pressure sensor is located at the right side of the air chamber. (☞ 6-29)



TP SENSOR

- The throttle position sensor is installed on the No.2 throttle body. (CF 6-31)

**ECT SENSOR**

- The engine coolant temperature sensor is installed on the cylinder head. (CF 6-32)

 ECT sensor: 18 N·m (1.8 kgf-m, 13.0 lb-ft)

**SPEED SENSOR**

- The speed sensor is installed on the final gear case. (CF 6-34)

**IAT SENSOR**

- The intake air temperature sensor is installed on the right side of the air chamber. (CF 6-36)

**AP SENSOR**

- The atmospheric pressure sensor is located at the right side of the leg shield brace. (CF 6-37)

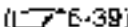

TO SENSOR

- The tip over sensor is located under the combination meter.
( 6-38)

NOTE:

When installing the TO sensor, bring the "UPPER" letter to the top.

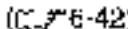

H₂O₂ SENSOR (E-02, 19)

- The heated oxygen sensor is installed on the exhaust pipe.
( 6-42)

▲ WARNING

Do not remove the H₂O₂ sensor while it is hot.

CAUTION

Be careful not to expose it to excessive shock.
Do not use an impact wrench while removing or installing the H₂O₂ sensor unit.
Be careful not to twist or damage the sensor lead wire.



CAUTION

Do not apply oil or other materials to the sensor air hole.

 H₂O₂ SENSOR: 47.5 N·m (4.75 kgf·m, 34.3 lb-ft)

CVT PULLEY POSITION SENSOR

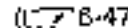
- The CVT pulley position sensor is mounted on the CVT cover.
( 6-47)



CVT SECONDARY PULLEY REVOLUTION SENSOR

- The secondary pulley revolution sensor is located underneath the CVT assembly. ( 6-51)



FUEL SYSTEM AND THROTTLE BODY

CONTENTS

FUEL SYSTEM	7- 2
FUEL TANK COMPONENTS	7- 2
FUEL TANK REMOVAL	7- 3
FUEL TANK INSTALLATION	7- 4
FUEL TANK PRESSURE CONTROL (FTPC) VALVE	
INSPECTION	7- 4
FUEL PRESSURE INSPECTION	7- 5
FUEL PUMP INSPECTION	7- 6
FUEL PUMP RELAY INSPECTION	7- 6
FUEL PUMP COMPONENTS	7- 7
FUEL PUMP/FUEL LEVEL GAUGE REMOVAL AND	
DISASSEMBLY	7- 7
FUEL MESH FILTER INSPECTION AND CLEANING	7-10
FUEL LEVEL GAUGE INSPECTION	7-10
FUEL PUMP/FUEL LEVEL GAUGE REASSEMBLY AND	
INSTALLATION	7-11
THROTTLE BODY	7-14
THROTTLE BODY COMPONENTS	7-14
THROTTLE BODY REMOVAL	7-15
THROTTLE BODY DISASSEMBLY	7-17
THROTTLE BODY CLEANING AND INSPECTION	7-19
IAC VALVE INSPECTION	7-20
THROTTLE BODY REASSEMBLY	7-20
THROTTLE BODY INSTALLATION	7-22
THROTTLE CABLE ADJUSTMENT	7-23
TP SENSOR ADJUSTMENT	7-23
FUEL INJECTOR REMOVAL	7-23
FUEL INJECTOR INSPECTION	7-23
FUEL INJECTOR INSTALLATION	7-23
THROTTLE VALVE SYNCHRONIZATION	7-24

⚠ WARNING

Gasoline must be handled carefully in an area well ventilated and away from fire or sparks.

FUEL SYSTEM

FUEL TANK COMPONENTS

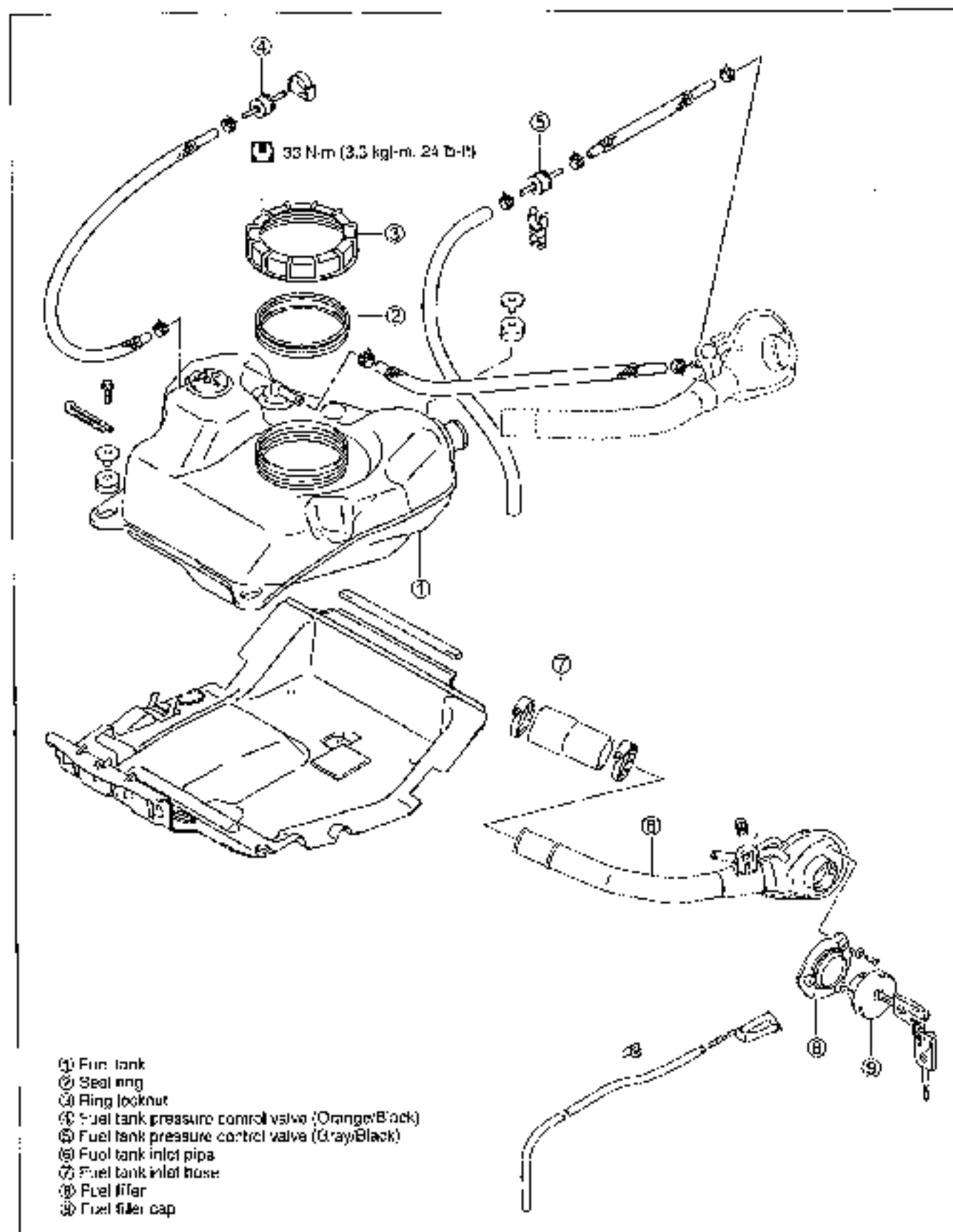

FUEL TANK REMOVAL

The fuel tank is located under the seat.

- Remove the following parts. (☞ 9-6)
 - Seat
 - Battery cover
 - Center frame cover
 - Frame covers
 - Pillion rider handles
 - Lower frame cover
 - Helmet box cover
 - Helmet box
- Loosen the fuel tank inlet hose clamp.
- Disconnect the fuel tank breather hose ①.
- Remove the fuel tank inlet hose ② along with the fuel tank inlet pipe ③.



- Disconnect the fuel pump/fuel level gauge coupler ④.
- Disconnect the fuel feed hose ⑤.
- Disconnect the fuel cut valve hose ⑥.

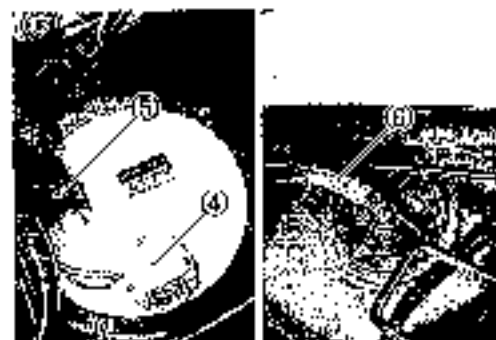

- Remove the fuel tank mounting bolts.



- Remove the fuel tank sideward.

⚠ WARNING

Gasoline is highly flammable and explosive. Keep heat, spark and flame away.



FUEL TANK INSTALLATION

Installation is in the reverse order of removal.

FUEL TANK PRESSURE CONTROL (FTPC) VALVE INSPECTION

Two kinds of the FTPC valve are equipped in the fuel tank, they can be distinguished by the color.

Fuel inlet side: (1) Gray/Black

Fuel tank side: (2) Orange/Black

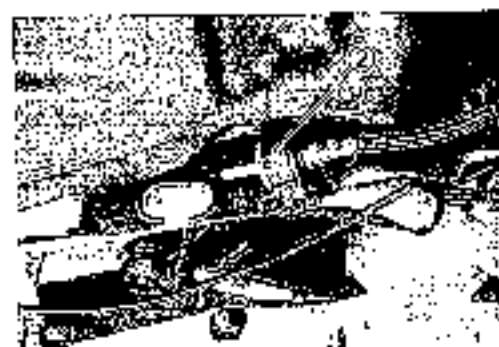

Check FTPC valve if air can pass through smoothly when blown from the orange color side or gray color side and not from the other side.

Should any abnormal condition be found, replace the valve with a new one.

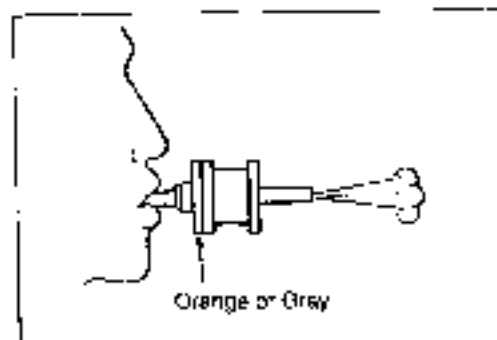

FUEL PRESSURE INSPECTION

- Remove the front box. (C79-18)
- Place a rag under the fuel feed hose.
- Disconnect the fuel feed hose at the fuel delivery pipe, and install the special tools between the fuel feed hose and fuel delivery pipe.

- 09940-40211: Fuel pressure gauge adaptor
- 09940-40220: Fuel pressure gauge hose attachment
- 09915-77330: Oil pressure gauge
- 09915-74520: Oil pressure gauge hose

Turn the ignition switch ON and check the fuel pressure.

DATA Fuel pressure: Approx. 300 kPa (3.0 kgf/cm², 43 psi)

If the fuel pressure is lower than the specification, inspect the following items.

- Fuel hose leakage
- Clogged fuel filter
- Pressure regulator
- Fuel pump

If the fuel pressure is higher than the specification, inspect the following items:

- Fuel pump check valve
- Pressure regulator

⚠ WARNING

- Before removing the special tools, turn the ignition switch to OFF position and release the fuel pressure slowly.
- Gasoline is highly flammable and explosive. Keep heat, spark and flame away.

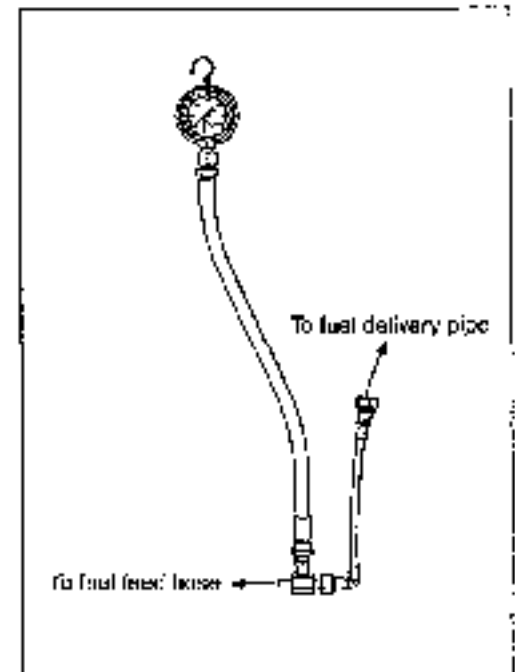

FUEL PUMP INSPECTION

Turn the ignition switch ON and check that the fuel pump operates for few seconds.

If the fuel pump motor does not make operating sound, replace the fuel pump assembly or inspect the fuel pump relay and tip over sensor.

FUEL DISCHARGE AMOUNT INSPECTION

⚠ WARNING

Gasoline is highly flammable and explosive. Keep heat, spark and flame away.

- Remove the front box. (C/F 9-18)
- Disconnect the fuel feed hose from the fuel delivery pipe.
- Place the measuring cylinder and insert the fuel feed hose end into the measuring cylinder.
- Disconnect the ECM lead wire coupler.
- With the lead wire's fastener (B) unlocked, pull out the power source lead wire (Yellow with red tracer) (1).
- Apply 12 volts to the fuel pump for 30 seconds and measure the amount of fuel discharged.

If the pump does not discharge the amount specified, it means that the fuel pump is defective or that the fuel filter is clogged.

**DATA Fuel discharge amount: More than 900 ml/30 sec.
(30.4/31.7 US/amp oz)/30 sec.**

NOTE:

The battery must be in fully charged condition.

FUEL PUMP RELAY INSPECTION

Fuel pump relay is located behind the front panel.

- Remove the front panel.
- Remove the fuel pump relay.

First, check the insulation between (1) and (2) terminals with pocket tester. Then apply 12 volts to (3) and (4) terminals, (1) to (3) and (2) to (4), and check the continuity between (1) and (2).

If there is no continuity, replace it with a new one.

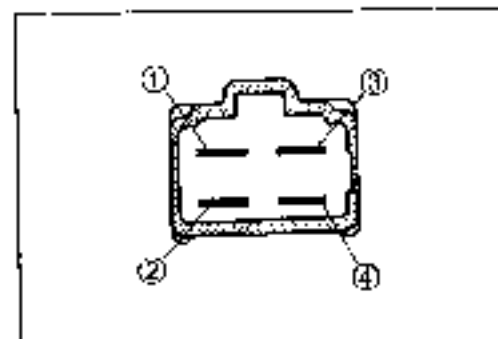

FUEL PUMP COMPONENTS

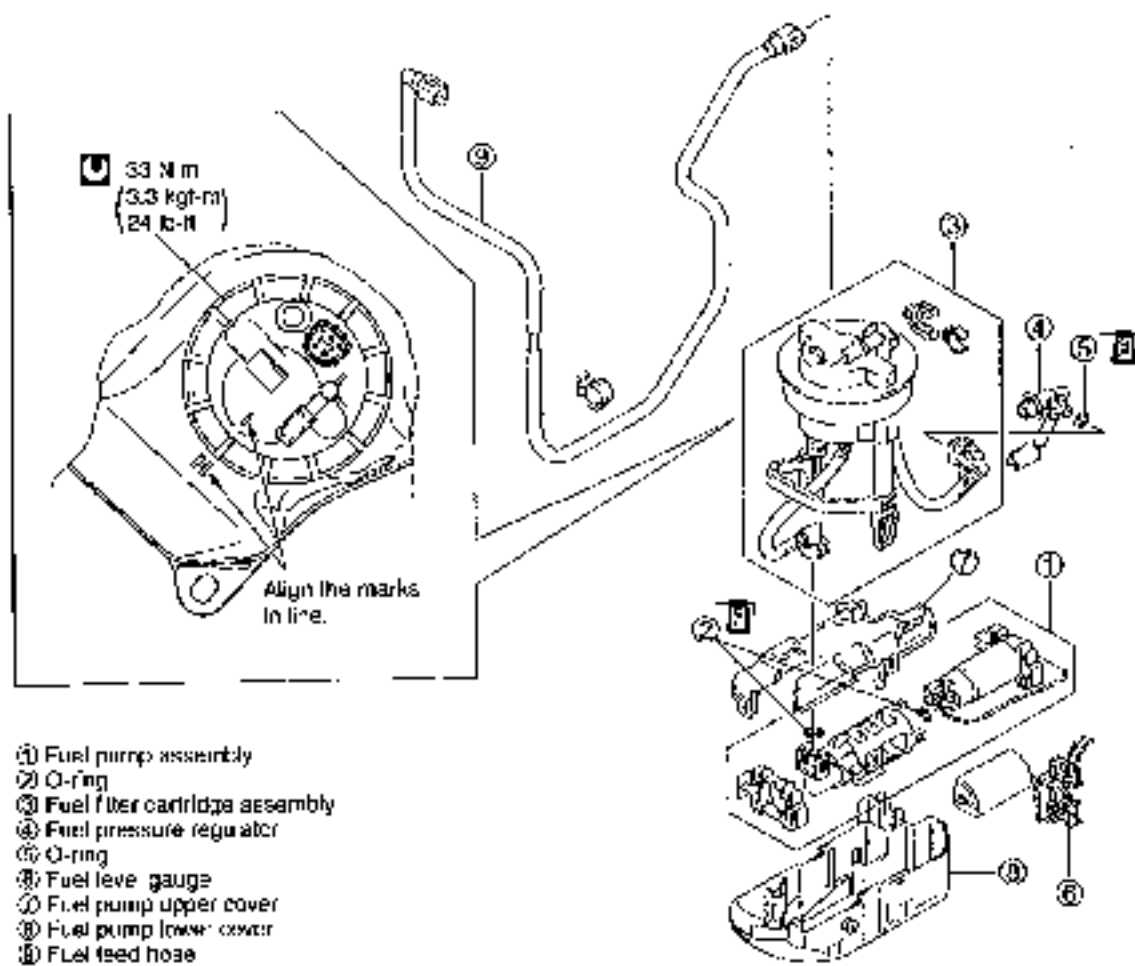

FUEL PUMP/FUEL LEVEL GAUGE REMOVAL AND DISASSEMBLY

- Remove the seat and battery cover.
- Disconnect the fuel pump/fuel level gauge coupler (①).
- Disconnect the fuel feed hose (②).

NOTE:

The fuel pump can be removed without removing the fuel tank.



7-8 FUEL SYSTEM AND THROTTLE BODY

- Remove the fuel pump ring locknut by using the special tool.

 09941-51010: Ring locknut wrench

⚠ WARNING

Gasoline is highly flammable and explosive. Keep heat, spark and flame away.



- Remove the fuel pump assembly.



- Disconnect the fuel level gauge lead wire coupler.



- Remove the fuel level gauge.



- Disconnect the ground wire.
- Remove the fuel pressure regulator.



- Disconnect the fuel pump lead wire coupler and ground wire.



- Remove the fuel pump lower case (1).



- Disconnect the fuel feed hose (2).



- Disconnect the fuel pump lead wire coupler.



- Remove the fuel pump from its holder.



FUEL MESH FILTER INSPECTION AND CLEANING

If the fuel mesh filter is clogged with sediment or rust, fuel will not flow smoothly and loss in engine power may result. Blow the fuel mesh filter with compressed air.

NOTE:

If the fuel mesh filter is clogged with many sediment or rust, replace the fuel filter cartridge with a new one.



FUEL LEVEL GAUGE INSPECTION

Measure resistance between the terminals when the float is at the position listed below.

 D9900-25008: Multi-circuit tester

Fuel level position	Resistance between terminals
130 mm (F)	11 - 13 Ω
82 mm (1/2)	Approx. 71.5 Ω
23 mm (E)	130 - 150 Ω

If the resistance measured is out of the specification, replace the gauge with a new one.

Fuel meter inspection (10-27)

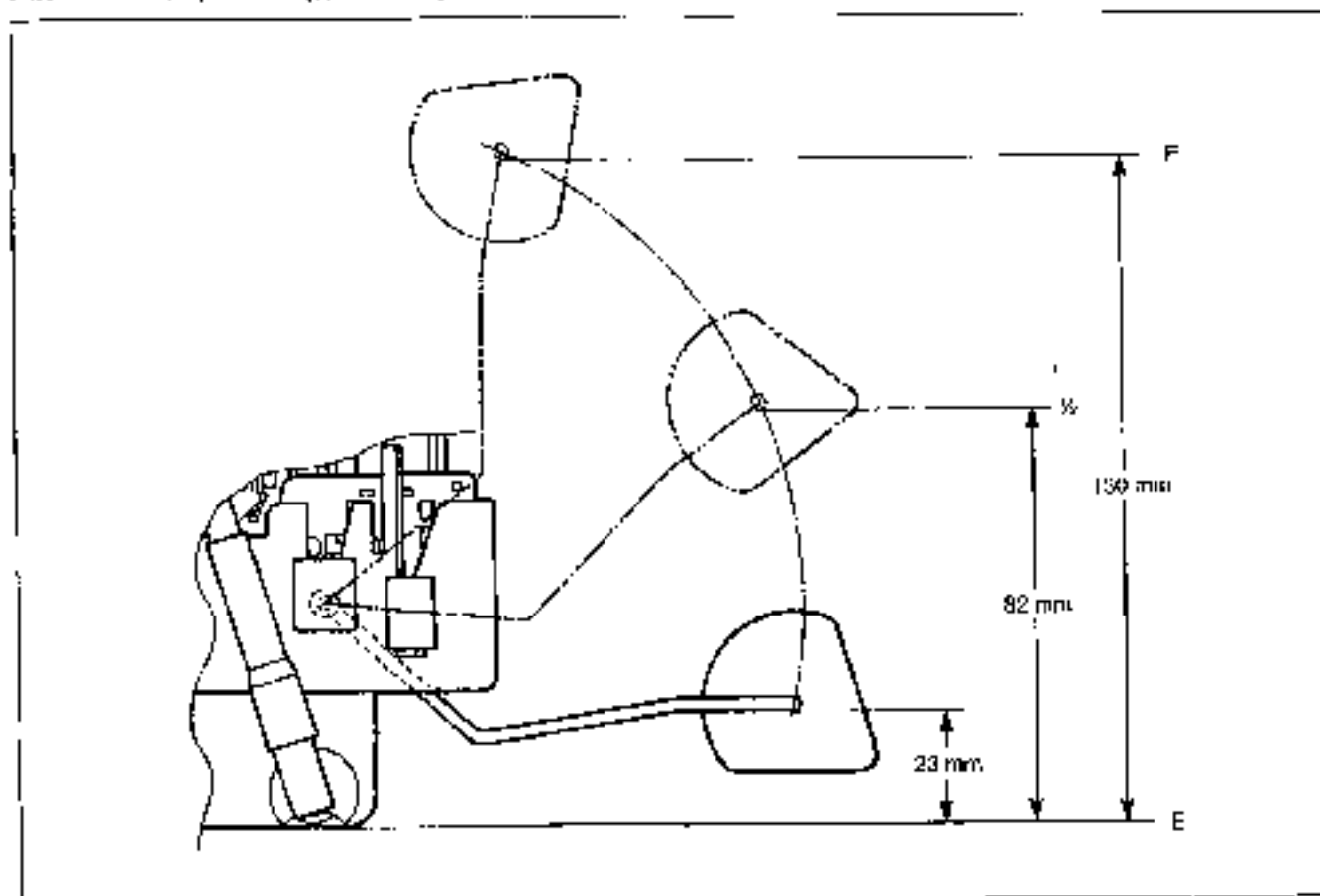

FUEL PUMP/FUEL LEVEL GAUGE REASSEMBLY AND INSTALLATION

Install the fuel pump/fuel level gauge in the reverse order of removal and disassembly, and pay attention to the following points:

- Install the new O-rings to the fuel pump, fuel pressure regulator and fuel feed hose.
- Apply thin coat of the engine oil to the O-rings.

CAUTION:

Use the new O-rings to prevent fuel leakage.

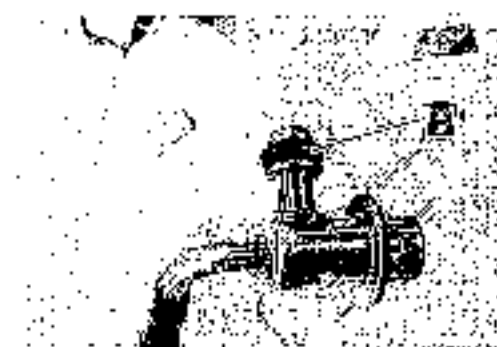
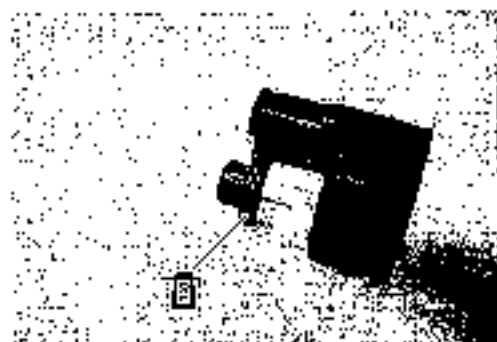

- Install the fuel pump to its holder and connect the lead wire coupler.



- Connect the fuel feed hose securely.



7-12 FUEL SYSTEM AND THROTTLE BODY

- Install the fuel pressure regulator and ground wire.



- Install the fuel level gauge.



- Connect the fuel pump lead wire coupler, ground wire and fuel level gauge lead wire coupler.



- Install the new seal ring ① to the fuel tank.
- Install the fuel pump assembly.



- Align the alignment marks (A) and (B) in line.



- Using the special tool, tighten the fuel pump ring locknut to the specified torque.

 09941-51010: Ring locknut wrench

 Ring locknut: 33 N·m (3.3 kgf-m, 24 lb-ft)



THROTTLE BODY

THROTTLE BODY COMPONENTS

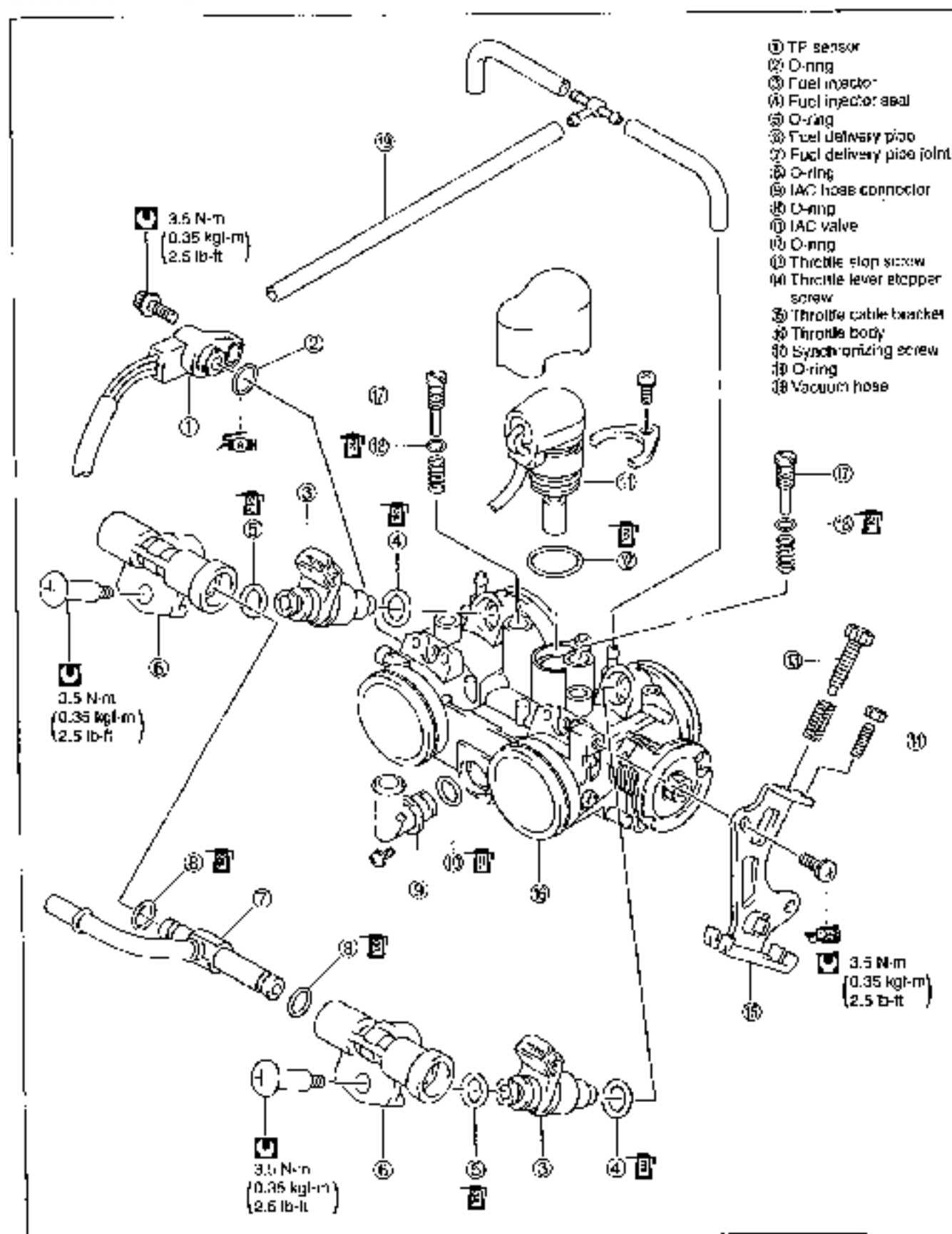

THROTTLE BODY REMOVAL

- Remove the front box. (☐ 9-18)
- Disconnect the PCV hose from the bottom side of the air cleaner box.
- Remove the air cleaner box ①.



- Remove the IAP sensor ②.
- Disconnect the IAT sensor coupler ③.



- Remove the PAIR solenoid valve ④.



- Loosen the respective throttle body clamp screws (air chamber side).



- Disconnect the IAC hose (5).
- Remove the air chamber (6).

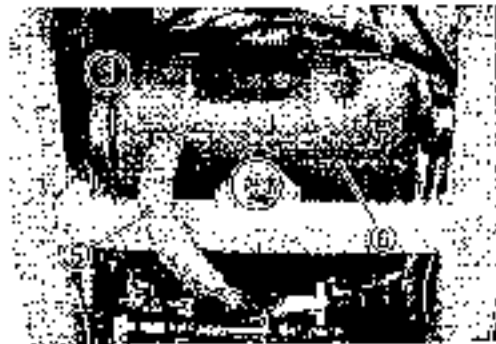

- Disconnect the various lead wire couplers.
 - ⑦ TPS
 - ⑧ IAC valve
 - ⑨ FI



- Disconnect the fuel feed hose (10).



- Disconnect the throttle cables.

CAUTION:

After disconnecting the throttle cables, do not snap the throttle valve from full open to full close. It may cause damage to the throttle valve and throttle body.

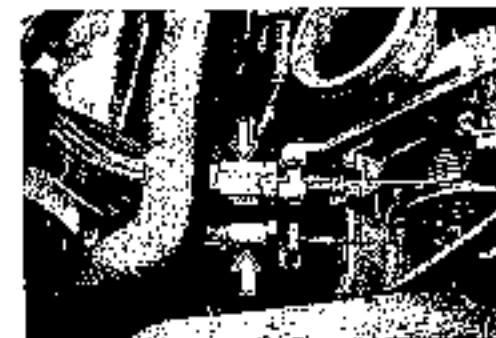

- Loosen the respective throttle body clamp screws (intake pipe side).
- Remove the throttle body assembly.



THROTTLE BODY DISASSEMBLY

- Remove the IAC hose.
- Remove the vacuum hoses.



- Remove the fuel delivery pipe.

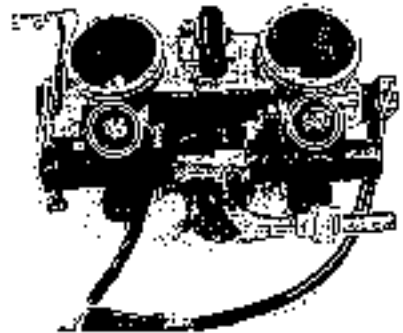

- Remove the fuel injectors.



- Remove the IAC valve.



- Remove the TPS.

NOTE:

Prior to disassembly, mark sensor's original position with a paint or scribe for accurate reinstallation.

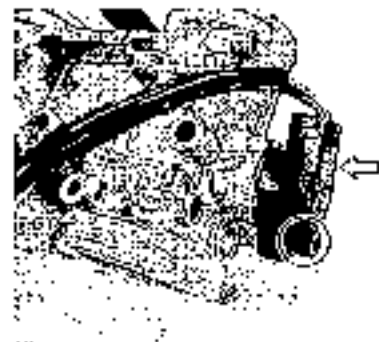

CAUTION

Never remove the throttle valve.



CAUTION

Avoid removing the throttle lever stopper screw (A).



- Remove the IAC hose connector.



- Remove the throttle cable bracket.



- Remove the synchronizing screws.

NOTE:

Before removing the synchronizing screw, determine the setting by slowly turning it clockwise and count the number of turns required to lightly seat the screw. This counted number is important when reassembling synchronizing screw to original position.

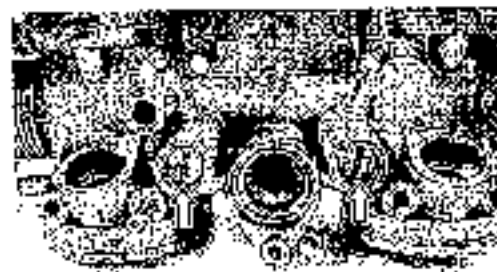

THROTTLE BODY CLEANING AND INSPECTION

▲ WARNING

Some carburetor cleaning chemicals, especially dip-type soaking solutions, are very corrosive and must be handled carefully. Always follow the chemical manufacturer's instructions on proper use, handling and storage.

- Clean all passageways with a spray-type carburetor cleaner and blow dry with compressed air.

CAUTION

Do not use wire to clean passageways. Wire can damage passageways. If the components cannot be cleaned with a spray cleaner it may be necessary to use a dip-type cleaning solution and allow them to soak. Always follow the chemical manufacturer's instructions for proper use and cleaning of the throttle body components. Do not apply carburetor cleaning chemicals to the rubber and plastic materials.

- Check following items for any damage or clogging.
 - O-ring
 - Throttle shaft bushing and seal
 - Throttle valve
 - Synchronizing screw
 - Fuel injector
 - Fuel injector filter
 - Injector seal
 - Vacuum hose
 - IAC hose

IAC VALVE INSPECTION

The IAC valve can be checked without removing it from the throttle body.

- Remove the front box. (☞ 9-1B)
- Disconnect the IAC valve lead wire coupler.
- Check the resistance between the terminals of the IAC valve.

DATA Resistance: Approx. 4 Ω (at 20 – 24 °C/68 – 75 °F)

09900-25008: Multi circuit tester set

Tester knob indication: Resistance (Ω)

If the resistance is not within the standard range, replace the IAC valve with a new one.

CAUTION

Do not attempt to disassemble the IAC valve. IAC valve is available only as an assembly.

- Remove the IAC valve cover (☞).
- Disconnect the IAC valve lead wire coupler.
- Connect the 12 V battery to the IAC valve terminals for more than 3 minutes and check for change of the IAC valve temperature from the cold condition.
- If the IAC valve is not warmed up, replace the IAC valve with a new one.

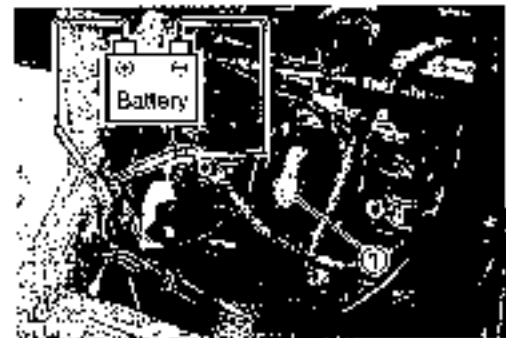

THROTTLE BODY REASSEMBLY

Reassemble the throttle body in the reverse order of disassembly.

Pay attention to the following points:

- Apply thread lock "1342" to the screws and tighten them.

09900-32050: THREAD LOCK "1342"

Throttle cable bracket screw:

3.5 N·m (0.35 kgf-m, 2.5 lb-ft)

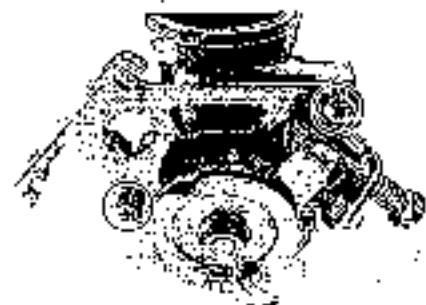

- Apply a small quantity of grease to the shaft end and seal lip.

 99000-25030: SUZUKI SUPER GREASE "A" (USA)
99000-25010: SUZUKI SUPER GREASE "A" (Others)

- With the TV fully closed, install the TP sensor to the original setting position.

 TP sensor mounting screw: 3.5 N·m (0.35 kgf-m, 2.5 lb-ft)

- Install the IAC valve.

CAUTION

Replace the O-ring with a new one.

- Apply thin coat of the engine oil to the new O-ring.

- Install the injector seal (1) and O-ring (2) to each fuel injector.
- Apply thin coat of the engine oil to the new O-ring and new seal.
- Install the fuel injectors by pushing them straight to each throttle body.

CAUTION

Replace the injector seal and O-ring with the new ones. Never turn the injector while pushing it.

- Install the fuel delivery pipe assembly to the throttle body assembly.

CAUTION

Never turn the fuel injectors while installing fuel delivery pipe.

- Tighten the fuel delivery pipe mounting screws.

 Fuel delivery pipe mounting screw:
3.5 N·m (0.35 kgf-m, 2.5 lb-ft)

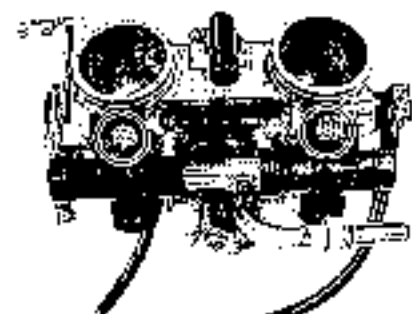
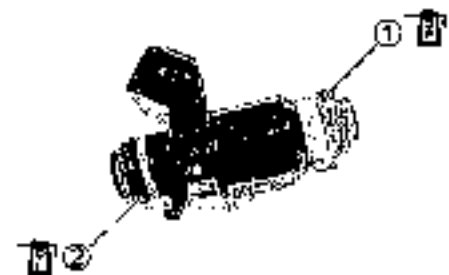
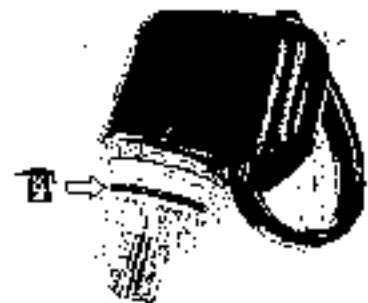

- Install the IAC hose connector.

CAUTION

Replace the O-ring with a new one.

- Apply thin coat of the engine oil to the new O-ring

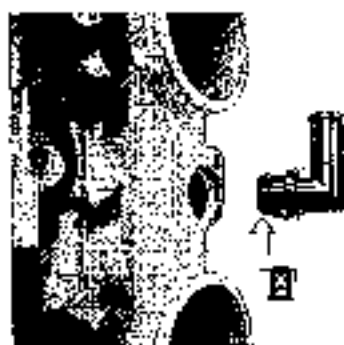

- Install the synchronizing screw to the original setting by turning the screw in until it lightly seats, and then backing it out the same number of turns counted during disassembly.

CAUTION

Replace the O-ring with a new one.

- Apply thin coat of the engine oil to the new O-ring



THROTTLE BODY INSTALLATION

Installation is in the reverse order of removal. Pay attention to the following points:

- Connect the throttle pulling cable and throttle returning cable to the throttle cable drum.
- Adjust the throttle cable play with the cable adjusters. Refer to page 2-19 for details.



THROTTLE BODY CLAMP POSITION

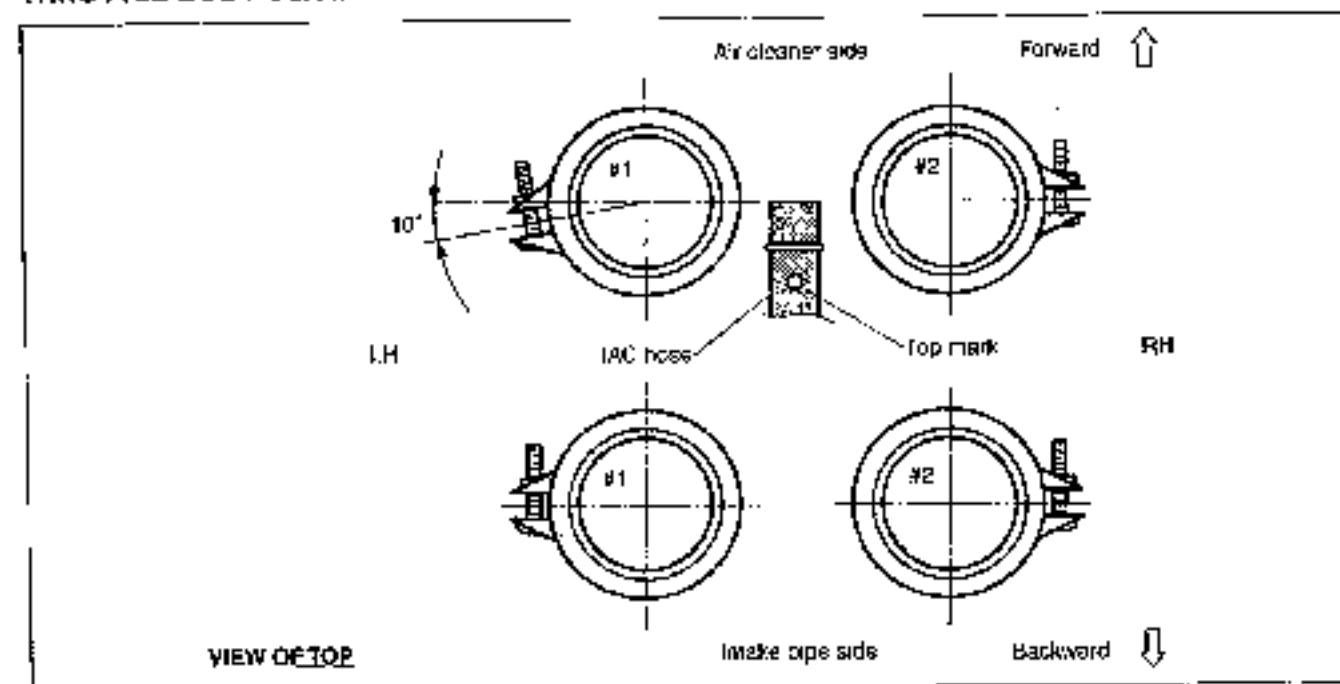

THROTTLE CABLE ADJUSTMENT

NOTE:

Minor adjustment can be made by the throttle grip side adjuster (C-7-18)

TP SENSOR ADJUSTMENT

- After checking or adjusting the throttle valve synchronization, adjust the TP sensor positioning as follows:
- After warming up engine, adjust the idling speed to $1\,200 \pm 100$ rpm.
- Stop the warmed-up engine and connect the special tool to the dealer mode coupler. (C-6-24)

09930-82710: Mode select switch

- Turn the special tool's switch ON.
- If the TP sensor adjustment is necessary, loosen the TP sensor mounting screw.
- Turn the TP sensor and bring the line to middle.
- Tighten the TP sensor mounting screw.

 TP sensor mounting screw: 3.5 N·m (0.35 kgf-m, 2.5 lb-ft)

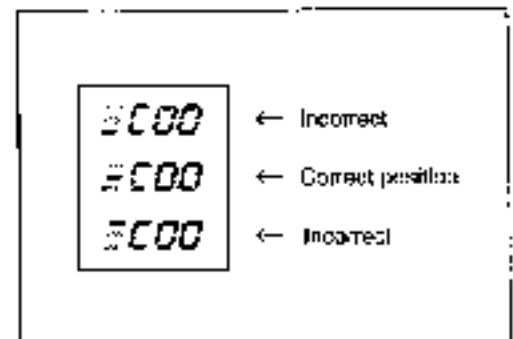

FUEL INJECTOR REMOVAL

- Remove the front box (C-9-18)
- Disconnect the injector couplers.
- Remove the fuel delivery pipe assembly (C-7-17)
- Remove the fuel injectors No.1 and No.2. (C-7-17)

FUEL INJECTOR INSPECTION

The fuel injector can be checked without removing it from the throttle body.

Refer to page 6-40 for details.

- Check the fuel injector filter for evidence of dirt and contamination. If present, clean and check for presence of dirt in the fuel lines and fuel tank.



FUEL INJECTOR INSTALLATION

- Apply thin coat of the engine oil to new injector seals and O-rings.
- Install the injector by pushing it straight to the throttle body. Never turn the injector while pushing it. (C-7-21)

THROTTLE VALVE SYNCHRONIZATION

Check and adjust the throttle valve synchronization between two cylinders. To synchronize throttle valves, disconnect the IAP sensor's vacuum hoses from the vacuum nipples on the respective throttle bodies and connect the vacuum balancer gauge hoses to each vacuum nipple.

09913-13121: Vacuum balancer gauge

NOTE:

Before balancing the throttle valves, calibrate each vacuum balancer gauge.

- Remove the front box. (7-9-18)
- Start up the engine and run it in idling condition for warming up.
- Stop the warmed-up engine.
- Connect a tachometer and start up the engine.
- Bring the engine rpm to 1 200 rpm by the throttle stop screw.
- Check the vacuum of the two cylinders and balance the two throttle valves with the synchronizing screw \odot .



NOTE:

- * *During balancing the throttle valves, always set the engine rpm at 1 200 rpm, using throttle stop screw.*
- * *After balancing the two valves, set the idle rpm to 1 200 rpm.*

For vacuum balancer gauge (09913-13121)

The vacuum gauge is positioned approx. 30° from the horizontal level, and in this position the two balls should be within one ball dia. If the difference is larger than one ball, turn the synchronizing screw on the throttle body and bring the ball to the same level.

A correctly adjusted throttle valve synchronization has the balls in the No.1 and No.2 at the same level.



COOLING AND LUBRICATION SYSTEM

CONTENTS

COOLING SYSTEM	8- 2
DESCRIPTION	8- 2
COOLING CIRCUIT	8- 2
OIL COOLER	8- 2
ENGINE COOLANT	8- 3
RADIATOR AND HOSES	8- 4
COOLING CIRCUIT INSPECTION	8- 4
RADIATOR CAP INSPECTION	8- 4
RADIATOR INSPECTION	8- 4
RADIATOR HOSE INSPECTION	8- 5
RADIATOR REMOVAL	8- 6
RADIATOR REMOUNTING	8- 7
RADIATOR RESERVOIR TANK	8- 7
COOLING FAN	8- 8
INSPECTION	8- 8
REMOVAL	8- 8
REMOUNTING	8- 9
COOLING FAN THERMO-SWITCH	8-10
REMOVAL	8-10
INSPECTION	8-11
INSTALLATION	8-11
ENGINE COOLANT TEMPERATURE SENSOR	8-12
REMOVAL	8-12
INSPECTION	8-13
INSTALLATION	8-13
THERMOSTAT	8-14
REMOVAL	8-14
INSPECTION	8-14
INSTALLATION	8-15
WATER PUMP	8-16
CONSTRUCTION	8-16
REMOVAL AND DISASSEMBLY	8-17
INSPECTION	8-19
REASSEMBLY AND INSTALLATION	8-21
LUBRICATION SYSTEM	8-25
OIL PRESSURE	8-25
OIL FILTER	8-25
OIL COOLER	8-25
OIL PRESSURE REGULATOR	8-25
OIL SUMP FILTER	8-25
OIL LEVEL SWITCH	8-25
OIL PRESSURE SWITCH	8-25
OIL PUMP	8-25
OIL RETURN PUMP	8-25
ENGINE LUBRICATION SYSTEM CHART	8-26
ENGINE LUBRICATION SYSTEM	8-27

COOLING SYSTEM DESCRIPTION

The engine is cooled by the forced circulation of engine coolant, using a high-capacity, centrifugal water pump, through water jackets formed in the cylinder and cylinder head, and through the radiator. The tube-and-fin type radiator is made of aluminum, which is characterized by lightness in weight and good heat dissipation.

A wax-pellet type thermostat is used to regulate the flow of engine coolant through the radiator. As the coolant temperature rises to about 88°C (190°F) the thermostat valve unseats and a normal coolant flow is established. At about 100°C (212°F) the thermostat becomes completely open and, as a result, heat is released to the atmosphere through the radiator core.

COOLING CIRCUIT

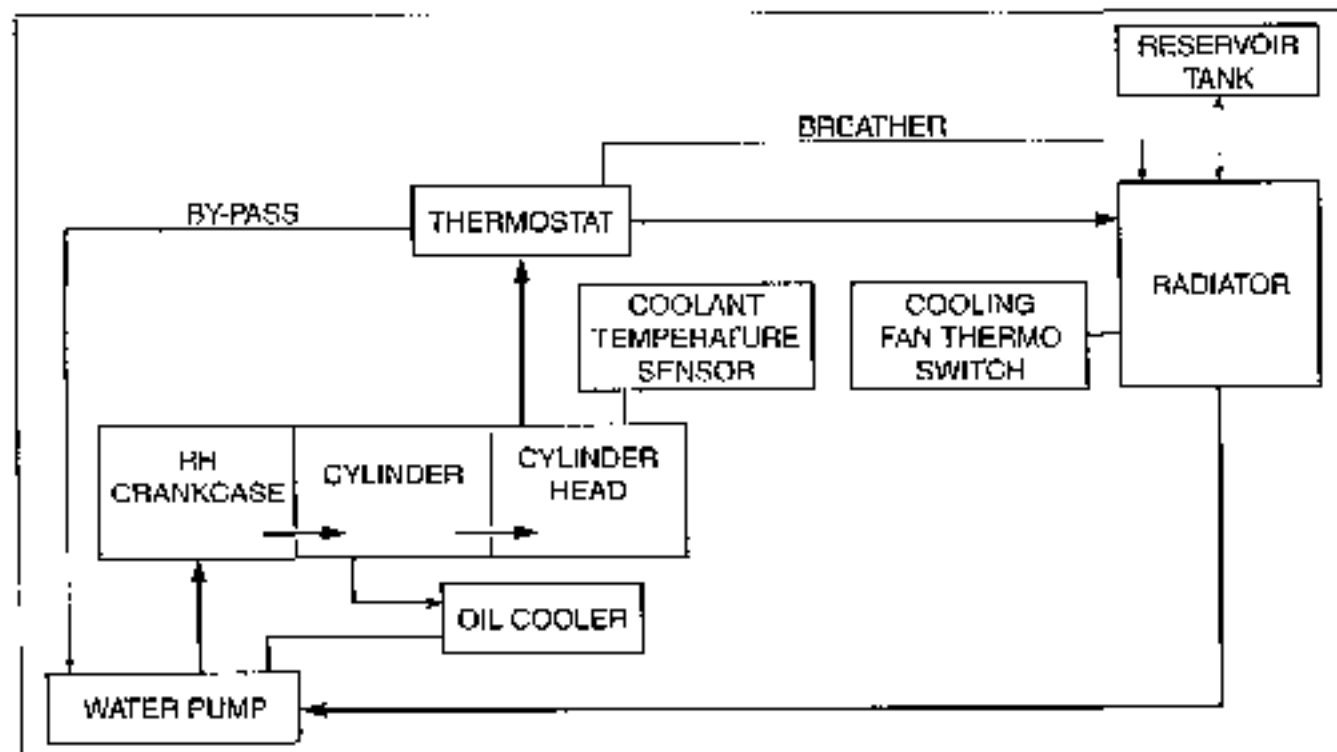

OIL COOLER

Oil cooler is sitting on the place of oil filter.

The engine oil is cooled by engine coolant, which is circulated through inside core of oil cooler.

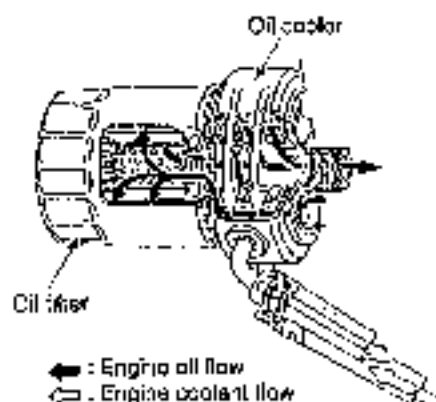

ENGINE COOLANT

At the time of manufacture, the cooling system is filled with a 50:50 mixture of distilled water and ethylene glycol anti-freeze. This 50:50 mixture will provide the optimum corrosion protection and excellent heat protection, and will protect the cooling system from freezing at temperatures above -31°C (-24°F).

If the vehicle is to be exposed to temperatures below -31°C (-24°F), this mixing ratio should be increased up to 55% or 60% according to the figure.

CAUTION

- * Use a high quality ethylene glycol base anti-freeze, mixed with distilled water. Do not mix an alcohol base anti-freeze and different brands of anti-freeze.
- * Do not put in more than 60% anti-freeze or less than 50%. (Refer to Right figure.)
- * Do not use a radiator anti-leak additive.

50% Engine coolant including reserve tank capacity

Anti-freeze	650 ml (1.4/1.1 US/imp. pt)
Water	650 ml (1.4/1.1 US/imp. pt)

Anti-freeze density	Freezing point
50%	-31°C (-24°F)
55%	-40°C (-40°F)
60%	-55°C (-67°F)

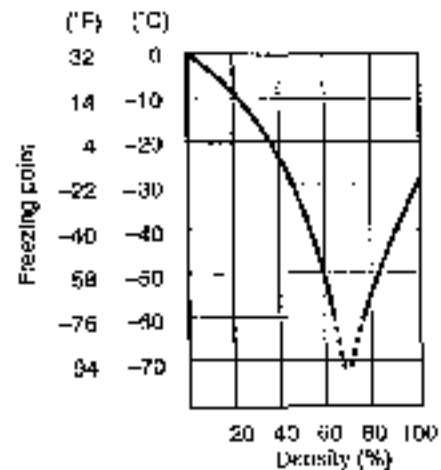

Fig.1 Engine coolant density-freezing point curve.

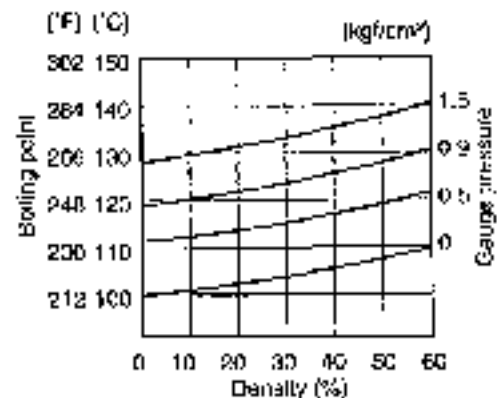

Fig.2 Engine coolant density-boiling point curve.

WARNING

- * You can be injured by scalding fluid or steam if you open the radiator cap when the engine is hot. After the engine cools, wrap a thick cloth around cap and carefully remove the cap by turning it a quarter turn to allow pressure to escape and then turn the cap all the way off.
- * The engine must be cool before servicing the cooling system.
- * Coolant is harmful;
 - If it comes in contact with skin or eyes, flush with water.
 - If swallowed accidentally, induce vomiting and call physician immediately.
 - Keep it away from children.

RADIATOR AND HOSES COOLING CIRCUIT INSPECTION

Before removing the radiator and draining the engine coolant, check the following.

Check the cooling system for leaks with a radiator tester ①.

Remove the radiator cap and connect the radiator tester to the filler. Pressurize the cooling system with 120 kPa (1.2 kgf/cm², 17 psi) of pressure, and then check if it holds the pressure for 10 seconds. If the cooling system does not hold the pressure for at least 10 seconds, check the entire cooling system for leaks. If a leak is found, replace the damaged part.

▲ WARNING

- * Do not open the radiator cap when the engine is hot, as you may be injured by escaping hot liquid or vapor.
- * When removing the radiator cap tester, put a rag on the filler to prevent the engine coolant from spraying out.

CAUTION

Do not exceed the radiator cap release pressure, or the radiator cap and subsequently the radiator, can be damaged.

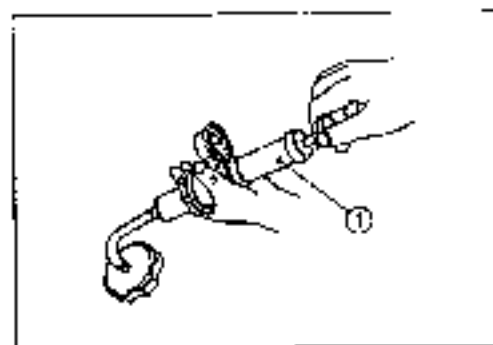

RADIATOR CAP INSPECTION

Check the radiator cap ② using a radiator tester ①.

Attach the radiator cap to the radiator tester as shown. Slowly apply pressure to the radiator cap; do not exceed 95 ~ 125 kPa (0.95 ~ 1.25 kgf/cm², 13.5 ~ 17.8 psi). If the radiator cap does not hold the pressure for at least 10 seconds, replace it with a new one.

DATA Radiator cap release pressure: 95 ~ 125 kPa
(0.95 ~ 1.25 kgf/cm², 13.5 ~ 17.8 psi)

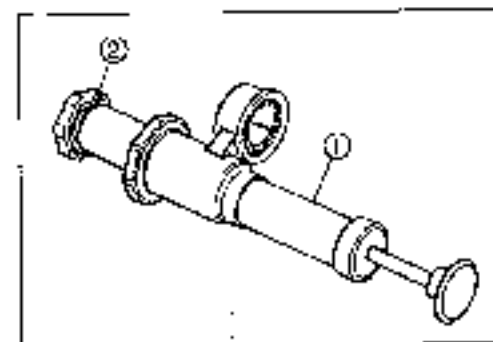

RADIATOR INSPECTION

Check the radiator for dirt and other foreign materials. If any are found, clean the radiator using compressed air. Also, repair any bent or dented fins using a small screwdriver.



RADIATOR HOSE INSPECTION

- Remove the leg shield and footboard. (☞ 9-10, 9-18)

Any radiator hose found in a cracked condition or flattened must be replaced.

Any leakage from the connecting section should be corrected by proper tightening.



RADIATOR REMOVAL

- Remove the leg shield and footboard. (See 9-10, p 18)
- Drain engine coolant by removing the drain plug.

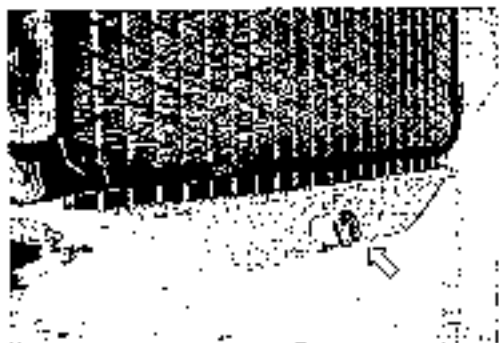

- Disconnect the fan motor lead wire coupler ①.
- Disconnect the upper and lower radiator hoses



- Remove the three mounting bolts and radiator assembly.



- Remove the radiator guard.

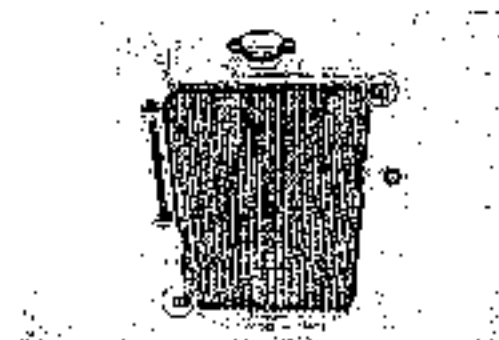

- Remove the four fixing places and the heat shield.



RADIATOR REMOUNTING

Install the radiator and the radiator hoses in the reverse order of removal.

Pay attention to the following points:

- Connect the fan motor lead wire coupler.
- Tighten the drain plug to the specified torque.

Drain plug: 5 N·m (0.6 kgf-m, 4.3 lb-ft)

- Pour engine coolant. (☞ 2-21)
- Bleed air from the cooling circuit. (☞ 2-21)

RADIATOR RESERVOIR TANK

REMOVAL/REMOUNTING

- Remove the reservoir tank mounting bolt.
- Disconnect the siphon hose from the reservoir tank and drain engine coolant.
- Install the reservoir tank in the reverse order of removal.
- Fill the reservoir tank to the upper level line.



COOLING FAN

INSPECTION

- Remove the leg side cover and footboard. (C7*9-12, 9-18)
- Disconnect the cooling fan motor lead wire coupler (1) and fan switch coupler (2).

Test the cooling fan motor for load current with an ammeter connected as shown in the illustration.

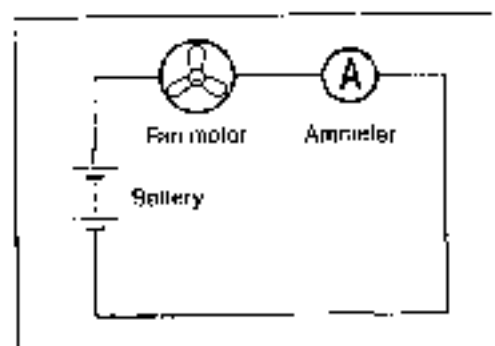

The voltmeter is for making sure that the battery applies 12 volts to the motor. With the motor with electric motor fan running at full speed, the ammeter should be indicating not more than 5 amperes.

If the fan motor does not turn, replace the motor assembly with a new one.

NOTE:

When making above test, it is not necessary to remove the cooling fan.

- Connection: (+) → Fan motor lead wire coupler BLUE
 (-) → Fan switch coupler BLACK (fan motor side)

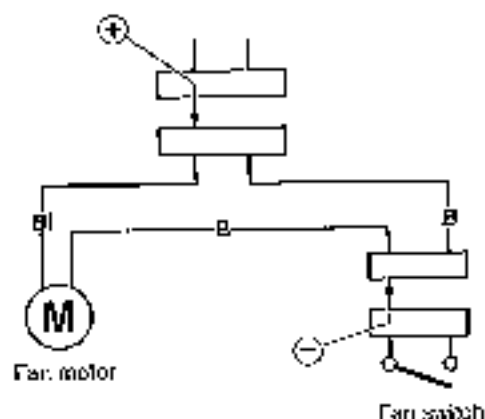

REMOVAL

- Remove the radiator. (C7*8-6)
- Disconnect the cooling fan switch coupler (1).
- Remove the three mounting bolts and the cooling fan unit.

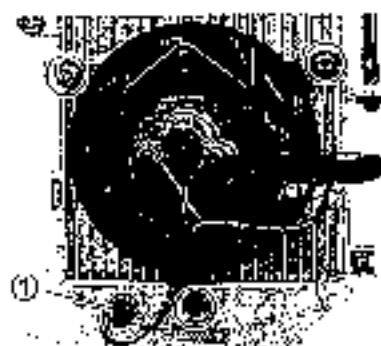

- Remove the cooling fan.



REMOUNTING

Remount the cooling fan in the reverse order of removal.

Pay attention to the following point:

- Tighten the cooling fan mounting bolts to the specified torque.

U Cooling fan mounting bolt: 6.5 N·m (0.65 kgf·m, 4.7 lb-ft)

COOLING FAN THERMO-SWITCH

The cooling fan is secured behind the radiator by three bolts and is automatically controlled by the thermo-switch. The thermo-switch remains open when the temperature of the engine coolant is low, but closes when the temperature reaches approximately 88°C (208°F) setting the cooling fan in motion.

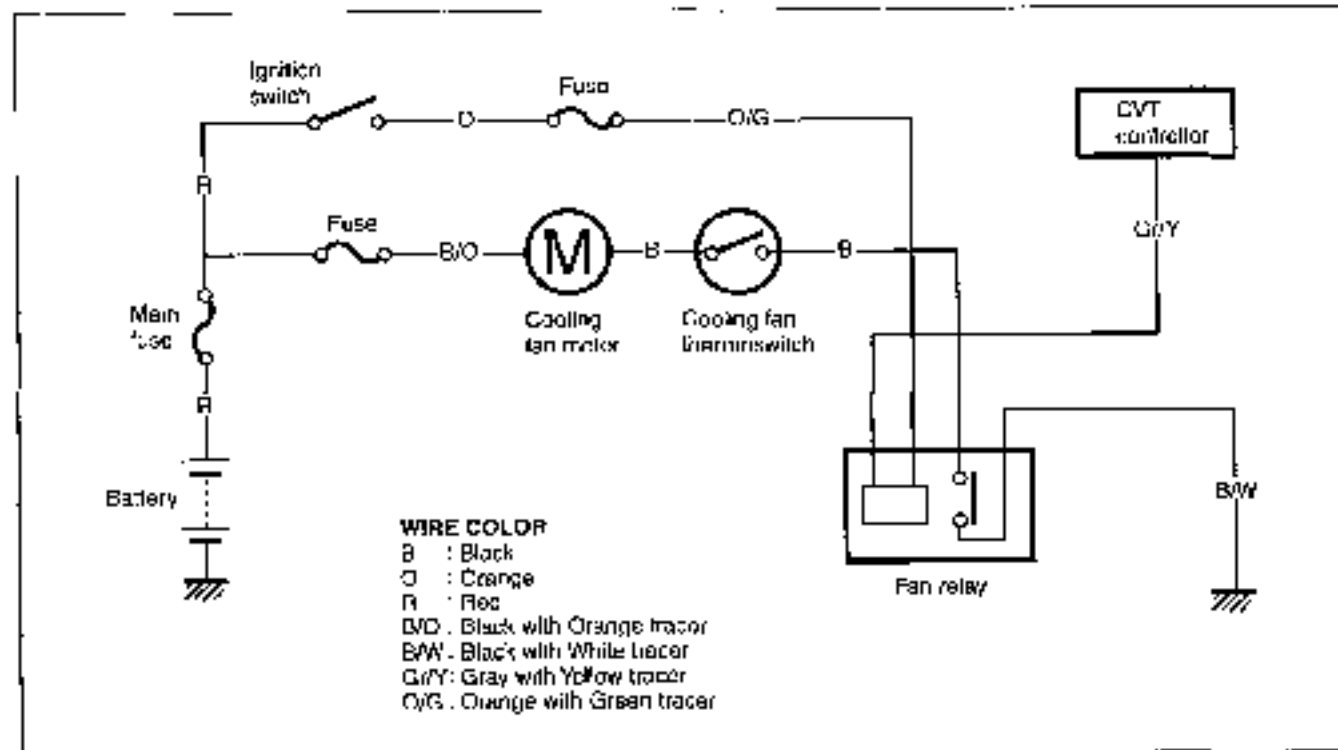

REMOVAL

- Remove the leg shield and footboard. (Fig 9-1B, 9-1R)
- Drain engine coolant. (Fig 2-20)
- Disconnect the cooling fan thermo-switch lead wire coupler ①.
- Remove the cooling fan thermo-switch ②.



INSPECTION

- Check the thermo-switch closing or opening temperatures by testing it at the bench as shown in the figure. Connect the thermo-switch ① to a circuit tester and place it in the oil contained in a pan, which is placed on a stove.
- Heat the oil to raise its temperature slowly and read the column thermometer ② when the switch closes or opens.

TOOL 09900-25008: Multi circuit tester set

TEST Tester knob indication: Continuity test (•••)

DATA Cooling fan thermo-switch operating temperature

Standard (OFF→ON): Approx. 98°C (208°F)

(ON→OFF): Approx. 92°C (198°F)

CAUTION

- Take special care when handling the cooling fan thermo-switch. Do not subject it to strong blows or allow it to be dropped.
- Do not contact the cooling fan thermo-switch ① and the column thermometer ② with a pan.

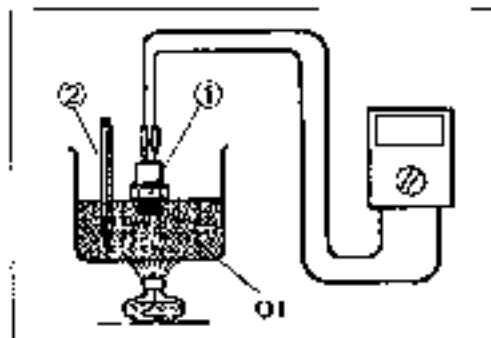

INSTALLATION

Install the cooling fan thermo-switch in the reverse order of removal. Pay attention to the following points:

- Apply engine coolant to the O-ring.
- Tighten the cooling fan thermo-switch to the specified torque.

T Cooling fan thermo-switch: 17 N·m (1.7 kgf·m, 12.3 lb-ft)

CAUTION

Replace the removed O-ring with a new one.

- Pour engine coolant. (CF-2-21)
- Bleed air from the cooling circuit. (CF-2-21)



ENGINE COOLANT TEMPERATURE SENSOR

The following circuit diagram shows the electrical wiring for the thermometer. The major components are temperature sensor in contact with coolant; and temperature indicator (engine coolant temperature meter).

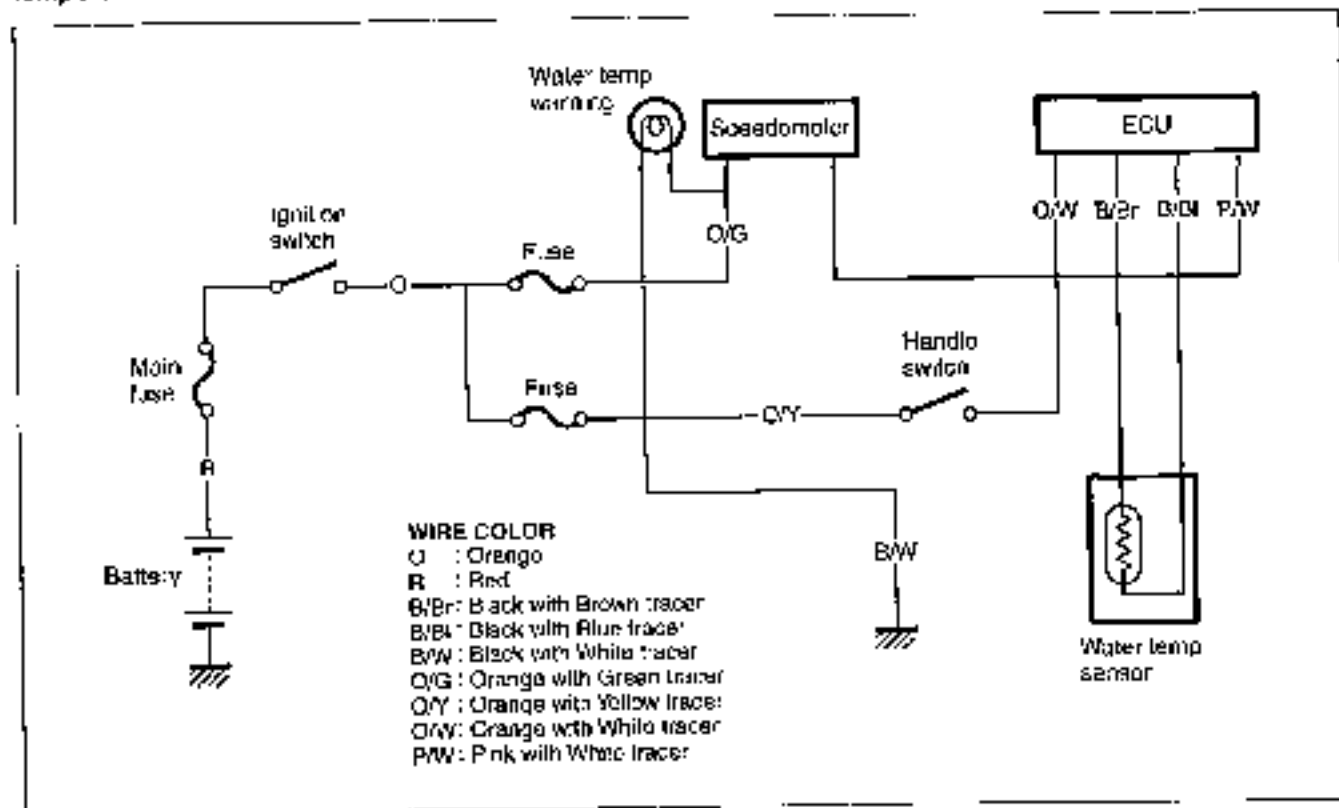

REMOVAL

- Remove the footboard. (☐ 9-18)
- Disconnect the engine coolant temperature sensor lead wire coupler ①.
- Remove the engine coolant temperature sensor ②.



INSPECTION

- Check the engine coolant temperature by testing it at the bench as shown in the figure. Connect the temperature sensor ① to a circuit tester and place it in the oil contained in a pan, which is placed on a stove.
- Heat the water to raise its temperature slowly and read the column thermometer ② and the ohmmeter.
- If the temperature sensor ohmic value does not change in the proportion indicated, replace it with a new one.

DATA Temperature sensor specification

Temperature	Standard resistance
20°C (68°F)	Approx. 2.45 kΩ
50°C (122°F)	Approx. 0.811 kΩ
80°C (176°F)	Approx. 0.318 kΩ
110°C (230°F)	Approx. 0.142 kΩ

If the resistance noted to show infinity or too much different resistance value, replace the temperature sensor with a new one.

CAUTION

- Take special care when handling the temperature sensor. It may cause damage if it gets a sharp impact.
- Do not contact the engine coolant temperature sensor ① and the column thermometer ② with a pan.

INSTALLATION

- Tighten the engine coolant temperature sensor to the specified torque

④ Engine coolant temperature sensor:

18 N·m (1.8 kgf-m, 13.0 lb-ft)

CAUTION

Replace the removed sealing washer ① with a new one.

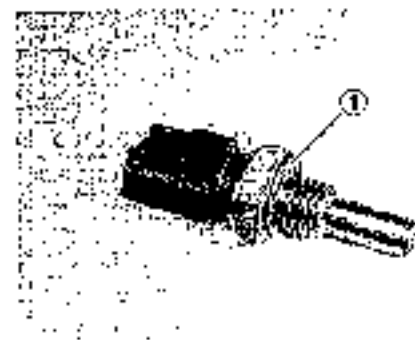
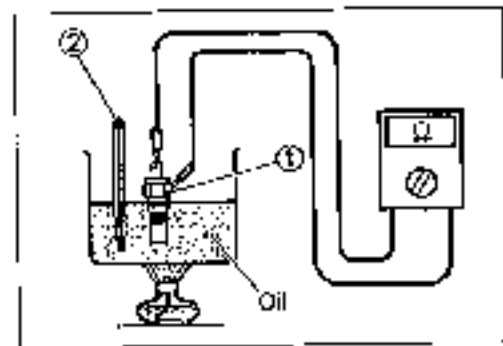

THERMOSTAT

REMOVAL

- Remove the leg shield and footboard. (CSF 9-10, 9-18)
- Drain a small amount of engine coolant. (CSF 2-20)
- Place a rag under the thermostat case.
- Remove the thermostat case.



- Remove the thermostat ①.

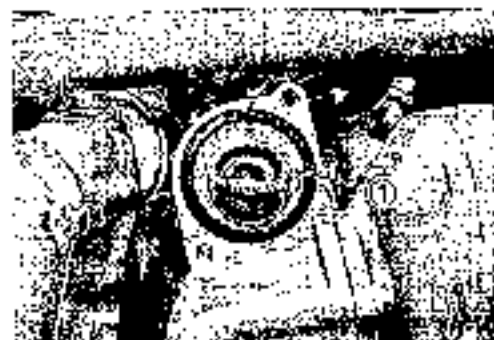

INSPECTION

Inspect the thermostat pellet for signs of cracking.

Test the thermostat at the bench for control action, in the following manner.

- Immerse the thermostat ① in the water contained in a beaker, as shown in the illustration. Note that the immersed thermostat is in suspension. Heat the water by placing the beaker on a stove and observe the rising temperature on a thermometer ②.
- Read the thermometer just when opening the thermostat. This reading, which is the temperature level at which the thermostat valve begins to open, should satisfy the standard value.

DATA Thermostat valve opening temperature
Standard: Approx. 88°C (190 °F)

CAUTION

- Do not contact the thermostat ① and the column thermometer ② with a pan.
- As the thermostat operating response to water temperature change is gradual, do not raise water temperature too quickly.
- The thermostat with its valve open even slightly under normal temperature must be replaced.

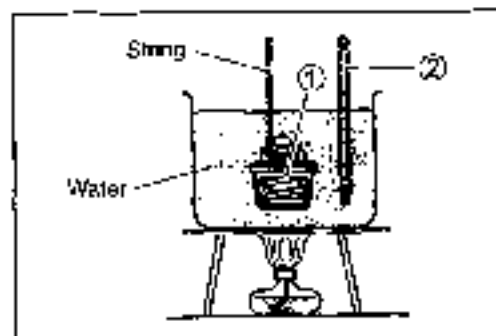

- Keep on heating the water to raise its temperature.
- Just when the water temperature reaches specified value, the thermostat valve should have lifted by at least 8.0 mm (0.31 in).

DATA Thermostat valve lift

Standard: Over 8.0 mm at 100°C

(Over 0.31 in at 212°F)

- A thermostat failing to satisfy either of the two requirements (start-to-open temperature and valve lift) must be replaced with a new one.

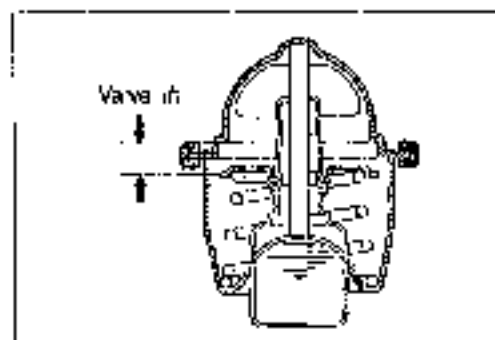
**INSTALLATION**

Install the thermostat in the reverse order of removal.

- Apply engine coolant to the rubber seal on the thermostat.

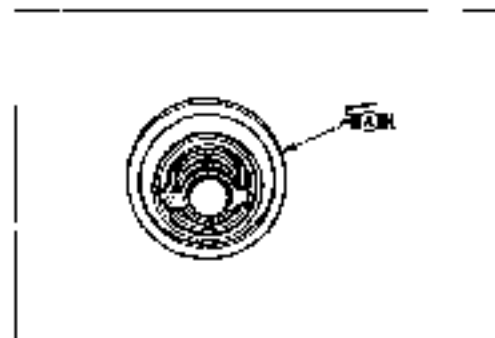

- Install the thermostat.

NOTE:

The jiggle valve (A) of the thermostat faces upside.



- Install the thermostat case
- Pour engine coolant. (C7-2-21)
- Bleed air from the cooling circuit. (C7-2-21)



WATER PUMP CONSTRUCTION

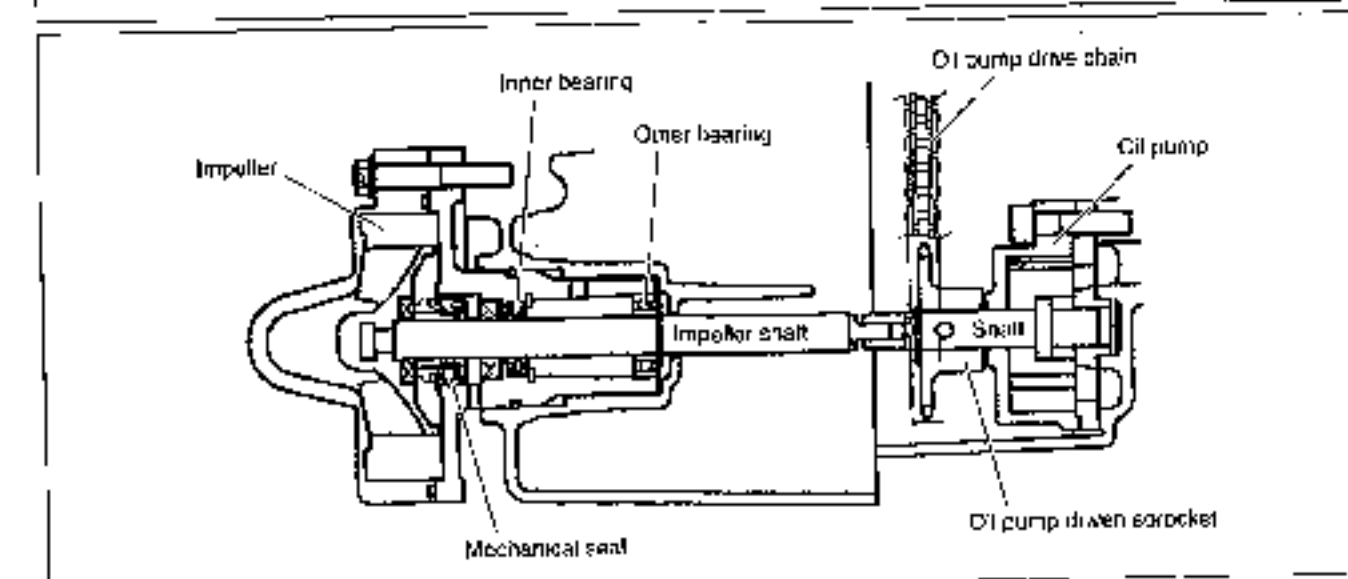
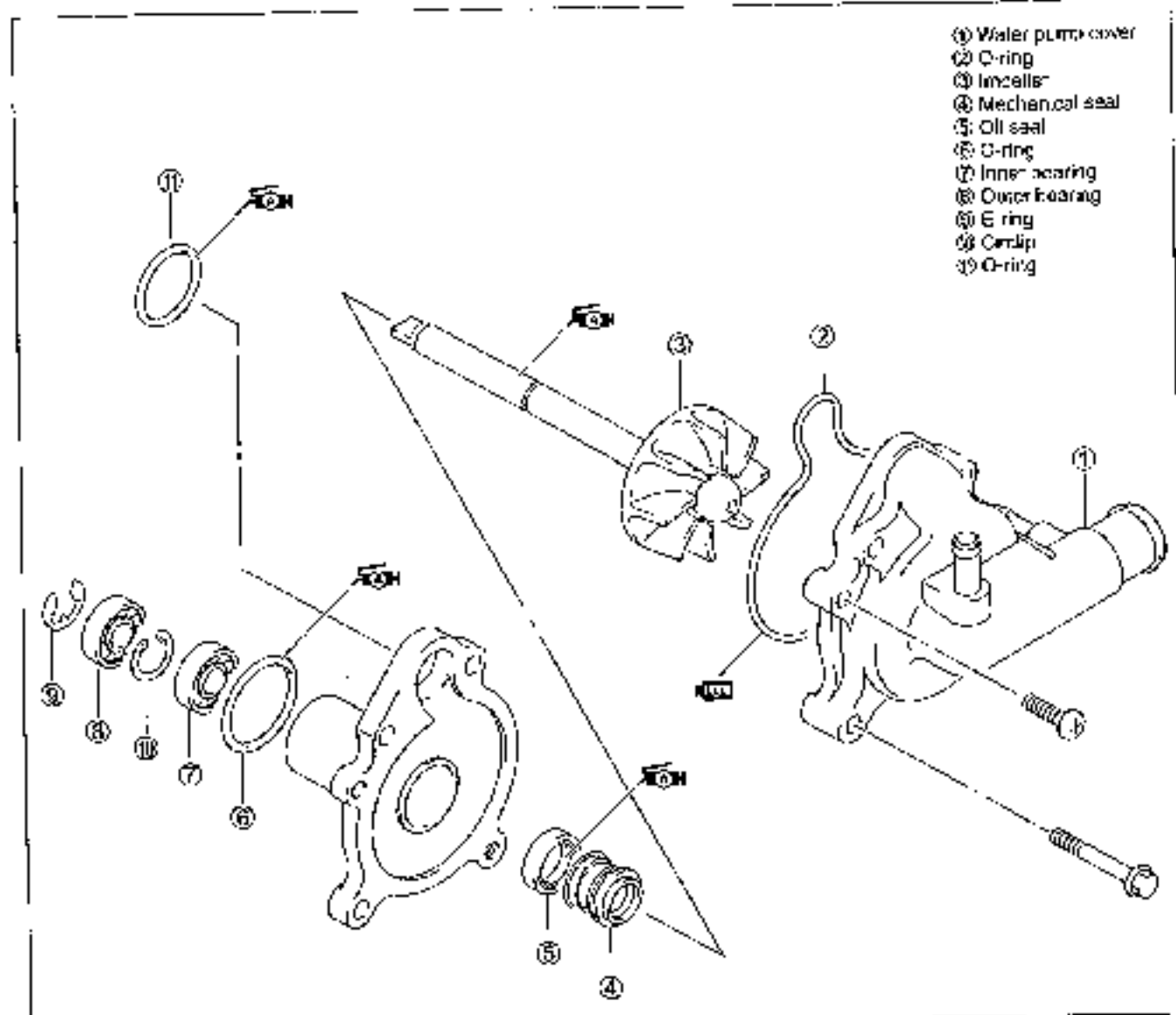

REMOVAL AND DISASSEMBLY

- Remove the leg shield and footboard. (C₁ 9-10, 9-18)
- Drain engine coolant. (C₁ 2-20)
- Hold the chassis by side stand.

⚠ WARNING

- * Do not open the radiator cap when the engine is hot, as you may be injured by escaping hot liquid or vapor.
- * The engine must be cool before servicing the cooling system.
- * Engine coolant may be harmful if swallowed or if it comes in contact with the skin or eyes. If engine coolant gets into the eyes or contacts the skin, flush the eyes or wash the skin thoroughly, with plenty of water. If engine coolant is swallowed, induce vomiting and call a physician immediately.

- Disconnect the radiator hose.
- Remove the water pump cover.

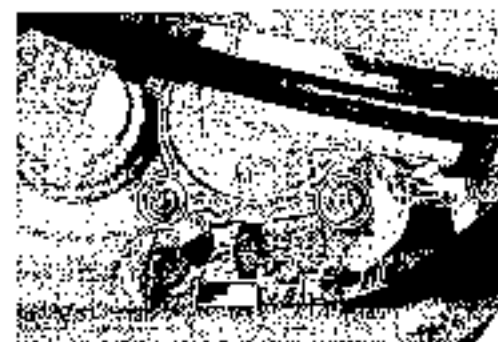
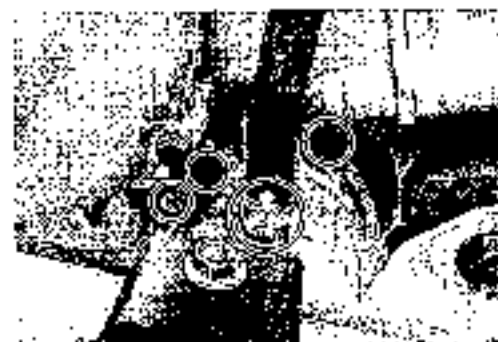

- Remove the cable clip.
- Remove the water pump body (1) with impeller (2).



- Remove the E-ring (1) and impeller (2).

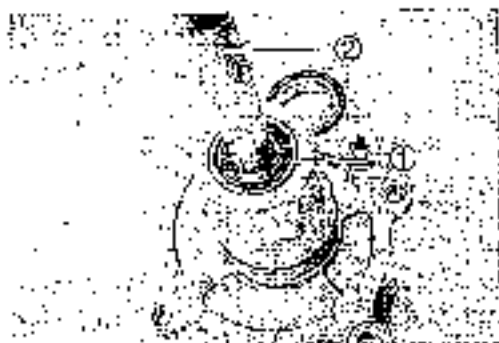

- Remove the mechanical seal using the special tool.

 09921-20240: Bearing remover set

NOTE:

If there is no abnormal condition, the mechanical seal removal is not necessary.

CAUTION

The removed mechanical seal must be replaced with a new one.



- Remove the outer bearing using the special tool.

 09921-20240: Bearing remover set

NOTE:

If there is no abnormal noise, bearing removal is not necessary.

CAUTION

The removed bearing must be replaced with a new one.



- Remove the circlip (1).

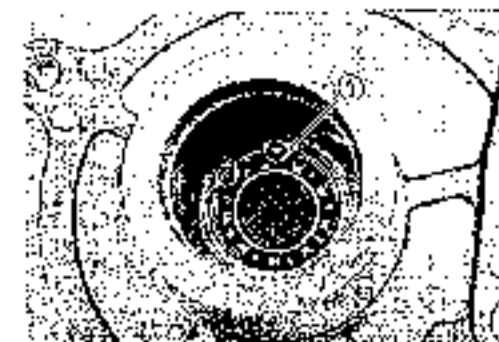

- Remove the inner bearing using the special tool.

 09921-20240: Bearing remover set

NOTE:

If there is no abnormal noise, bearing removal is not necessary.

CAUTION

The removed bearing must be replaced with a new one.

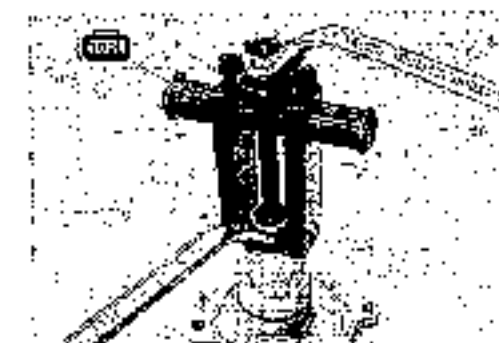

- Place a rag over the water pump body.
- Remove the oil seal using a suitable bar.

NOTE:

If there is no abnormal condition, the oil seal removal is not necessary.

CAUTION

The removed oil seal must be replaced with a new one.

- Remove the mechanical seal ring ① and the rubber seal ② from the impeller.

INSPECTION**BEARING**

- Inspect the play of the outer bearing and inner bearing by hand while it is in the water pump case.
- Rotate the inner race by hand to inspect for abnormal noise and smooth rotation.
- Replace the bearing if there is anything unusual.

MECHANICAL SEAL

- Visually inspect the mechanical seal for damage, with particular attention given to the sealing face.
- Replace the mechanical seal that shows indications of leakage.

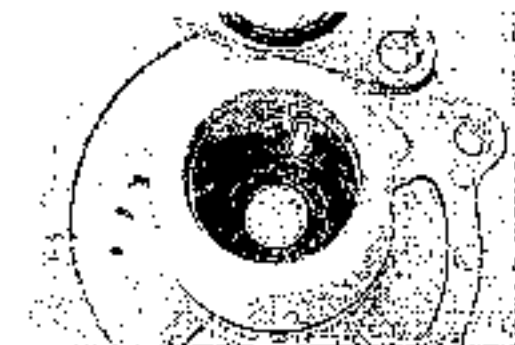
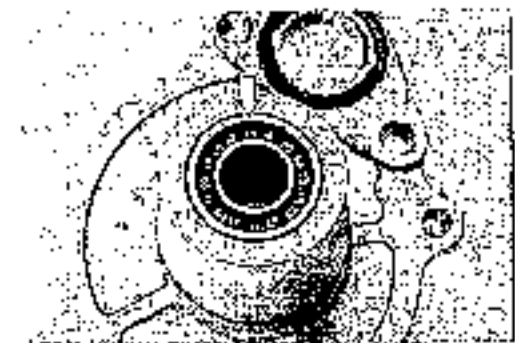
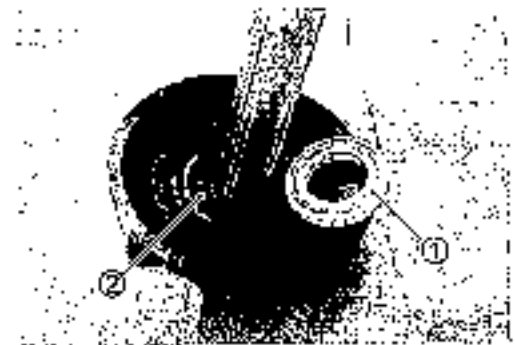
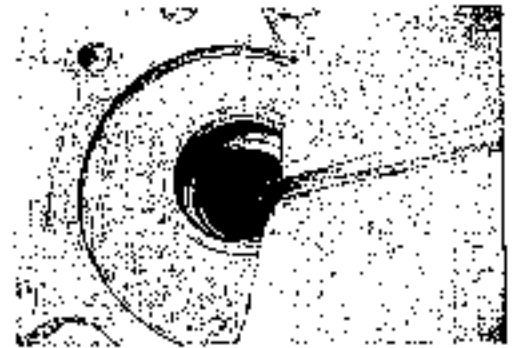

OIL SEAL

- Visually inspect the oil seal for damage, with particular attention given to the lip.
- Replace the oil seal that shows indications of leakage.

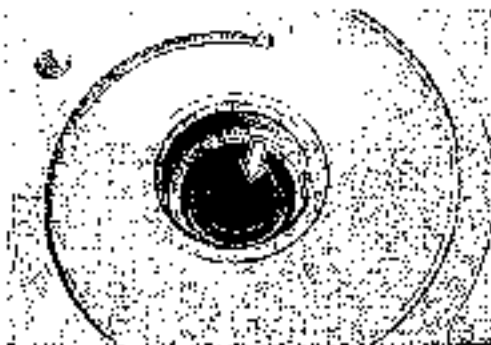

BEARING CASE/MECHANICAL CASE

- Visually inspect the bearing case and mechanical case for damage
- Replace the water pump body if necessary.

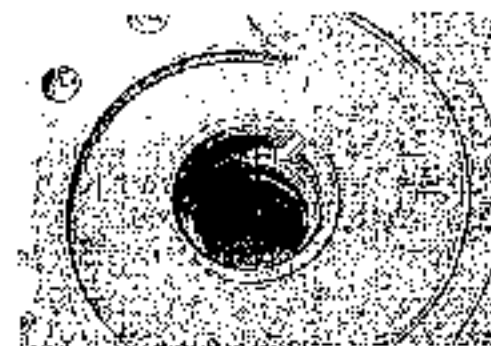

IMPELLER

- Visually inspect the impeller and its shaft for damage.



REASSEMBLY AND INSTALLATION

- Install the new inner bearing using the special tool.

 09913-70210: Bearing installer set

- Install the circlip ①.

- Install the new outer bearing using the special tool.

 09913-70210: Bearing installer set

- Install the new oil seal using the special tool.

 09913-70210: Bearing installer set

NOTE:

The stamped mark on the oil seal faces outside.

- Apply a small quantity of the SUZUKI SUPER GREASE "A" to the oil seal lip.

 99000-25030: SUZUKI SUPER GREASE "A" (USA)

99000-25010: SUZUKI SUPER GREASE "A" (Others)

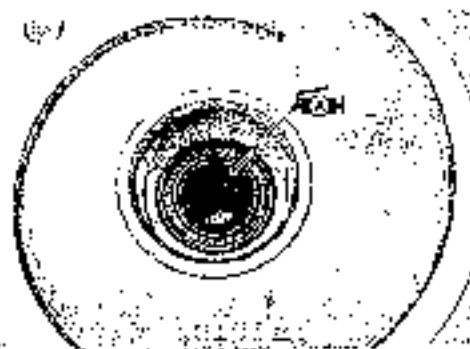
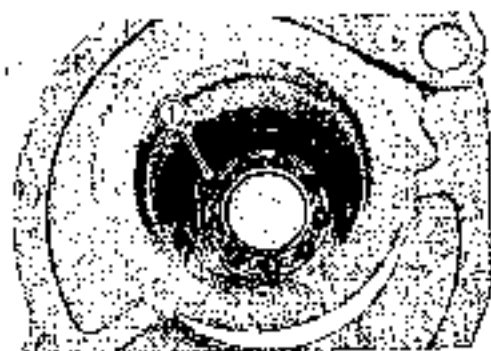

- Install the new mechanical seal using a suitable size socket wrench.

NOTE:

On the new mechanical seal, the sealer (A) has been applied.

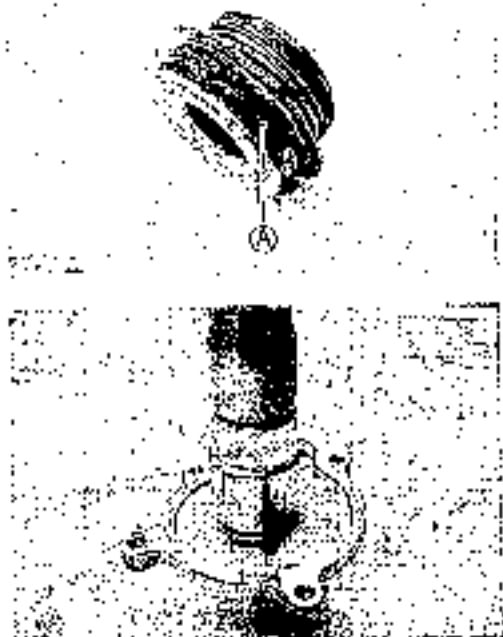

- Install the rubber seal (1) into the impeller.
- After wiping off the oily or greasy matter from the mechanical seal ring, install it into the impeller.

NOTE:

The paint marked side (A) of the mechanical seal ring faces the impeller.

Make sure the mechanical seal ring is fit into the impeller.

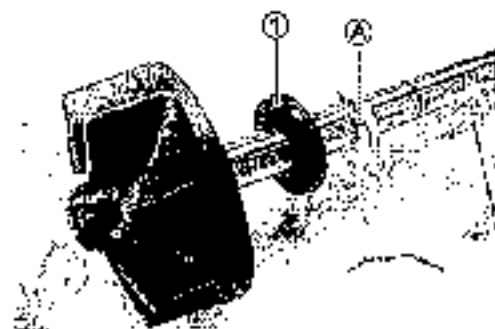

- Apply grease to the impeller shaft.

④ 99000-25030: SUZUKI SUPER GREASE "A" (USA)
99000-25010: SUZUKI SUPER GREASE "A" (Others)

- Install the impeller shaft to the water pump body.

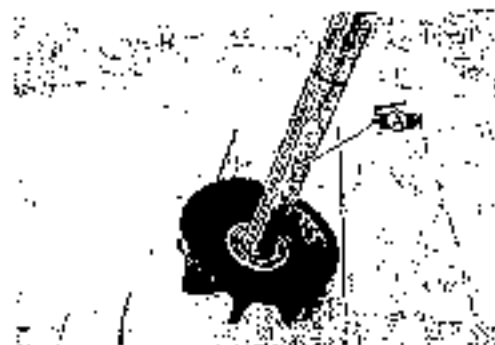

- Install the E-ring (1) to the impeller shaft.

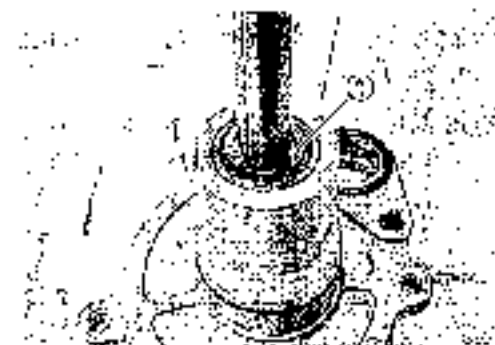

- Install the new O-rings ① and ②.
- Apply grease to the O-rings.

Part No. 99000-25030: SUZUKI SUPER GREASE "A" (USA)
Part No. 99000-25010: SUZUKI SUPER GREASE "A" (Others)

- Install the water pump body ① with impeller ② to the crank case.
- Fit the cable clip.

NOTE

Set the water pump shaft end ④ to the oil pump shaft ③ as shown in the figures.

- Install the O-ring to the water pump cover.

CAUTION

Use the new O-rings to prevent engine coolant leakage.

- Apply engine coolant to the O-ring.

- Install the water pump cover.

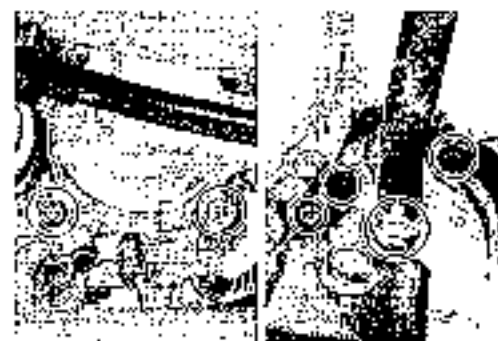
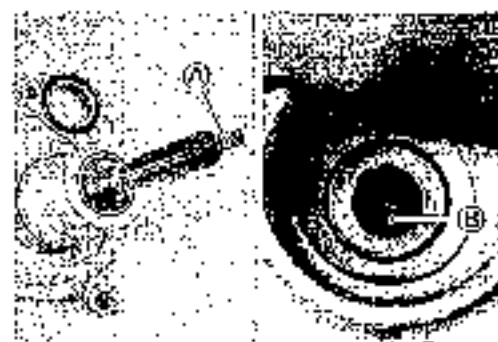
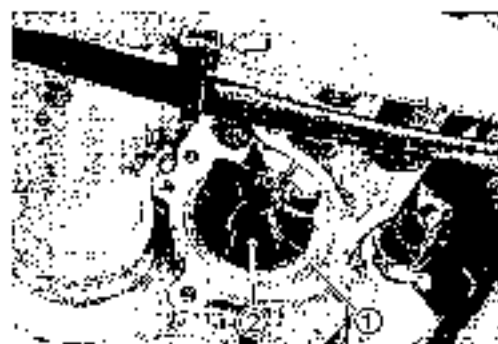
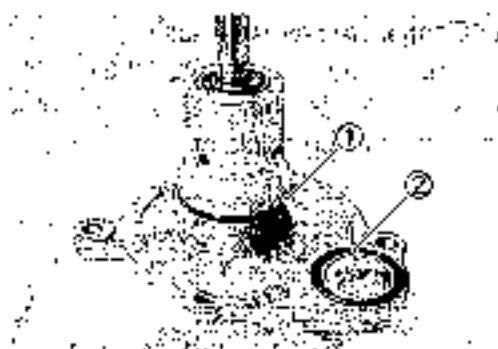

8-24 COOLING AND LUBRICATION SYSTEM

- Connect the radiator hose.
- Pour engine coolant. (☞ 2-21)
- Bleed air from the cooling circuit. (☞ 2-21)
- Install the leg shield and footboard.



LUBRICATION SYSTEM**OIL PRESSURE**

☐ 2-31

OIL FILTER

☐ 2-14

OIL COOLER

☐ 3-17, 3-63

OIL PRESSURE REGULATOR

☐ 3-44

OIL SUMP FILTER

☐ 3-44

OIL LEVEL SWITCH

☐ 10-29

OIL PRESSURE SWITCH

☐ 10-38

OIL PUMP

☐ 3-20, 3-60

OIL RETURN PUMP

☐ 3-21, 3-69

ENGINE LUBRICATION SYSTEM CHART

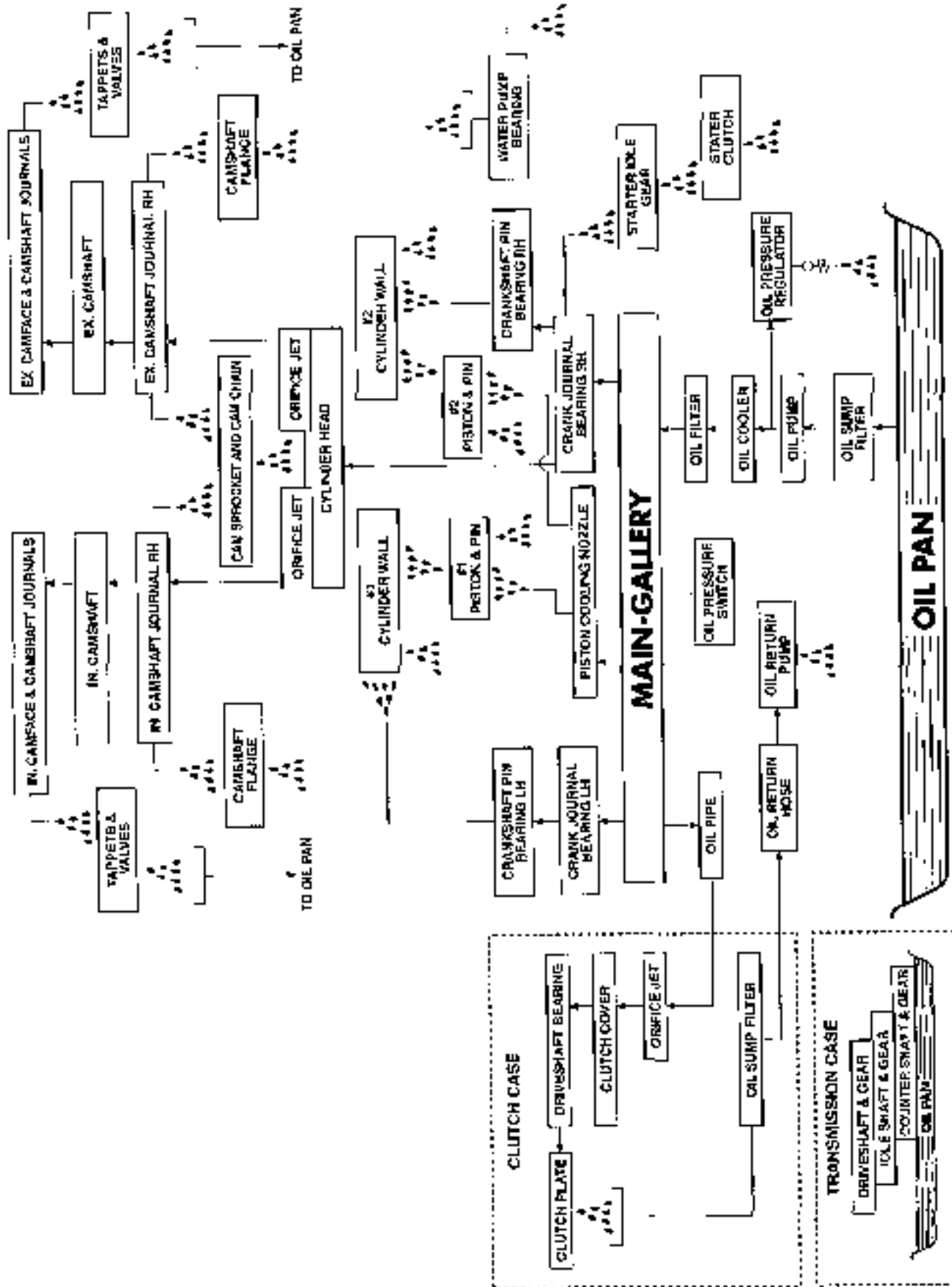

ENGINE LUBRICATION SYSTEM

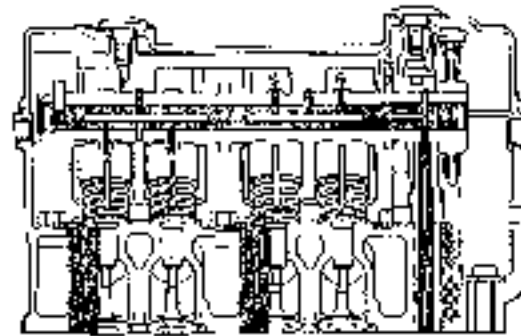

EXHAUST SIDE

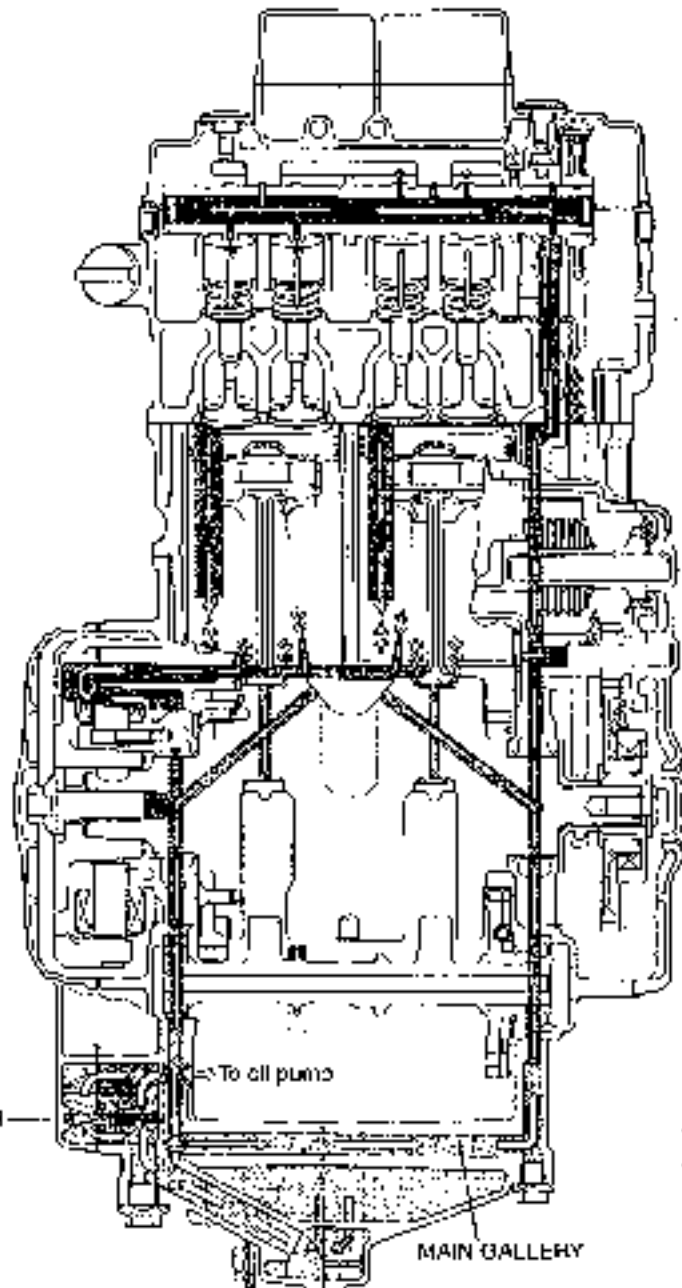

INTAKE SIDE

OIL SUMP FILTER

To oil pump

MAIN GALLERY

← LUBRICATION OIL
 ← RETURNED OIL

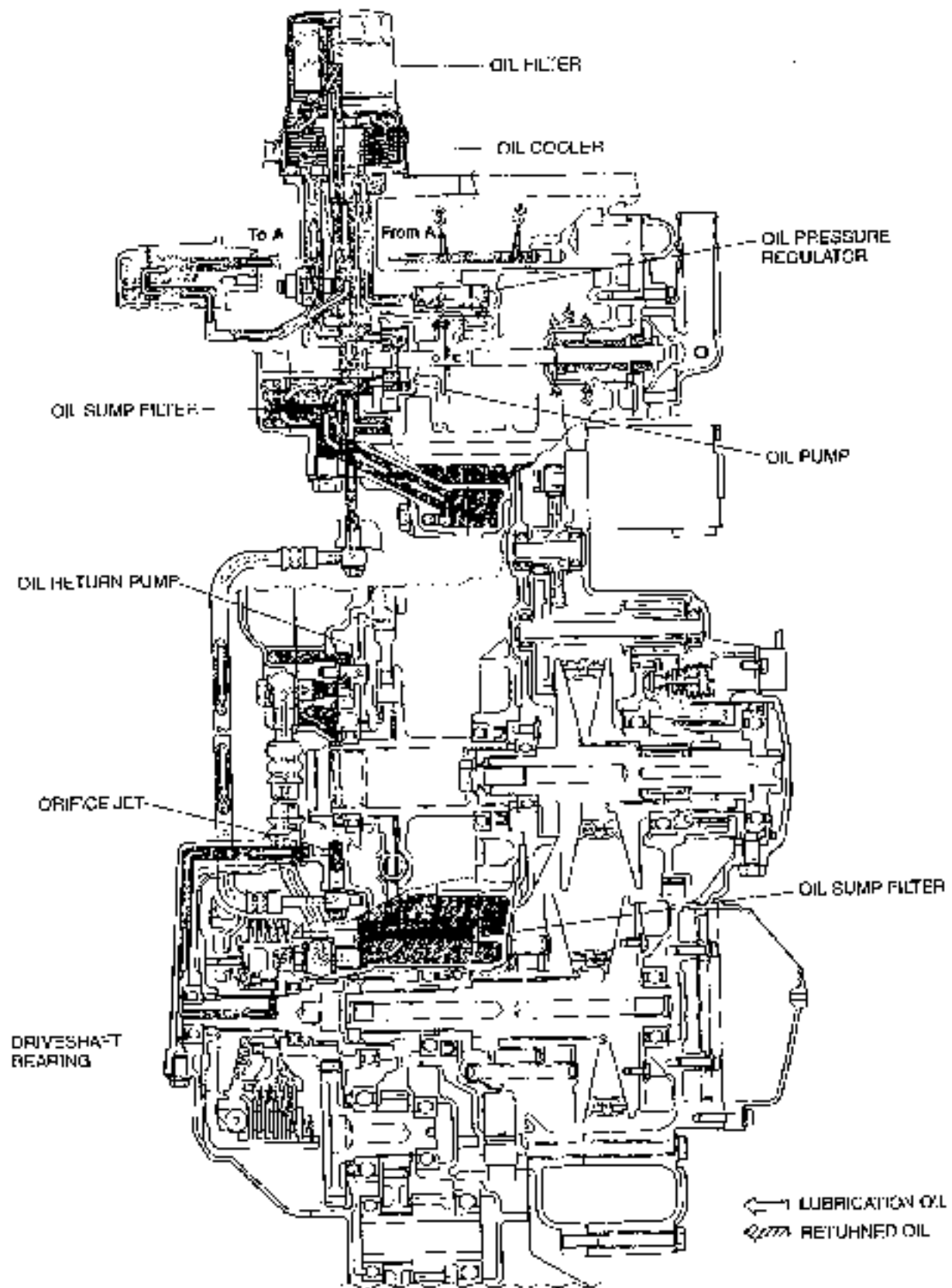

CHASSIS

CONTENTS

EXTERIOR PARTS	9- 2
CONSTRUCTION	9- 2
REMOVAL	9- 6
REMOUNTING	9-23
FRONT WHEEL	9-25
CONSTRUCTION	9-25
REMOVAL	9-26
INSPECTION AND DISASSEMBLY	9-27
REASSEMBLY AND REMOUNTING	9-29
FRONT FORK	9-32
CONSTRUCTION	9-32
REMOVAL AND DISASSEMBLY	9-33
INSPECTION	9-35
REASSEMBLY AND REMOUNTING	9-36
STEERING AND HANDLEBARS	9-40
CONSTRUCTION	9-40
REMOVAL	9-41
INSPECTION AND DISASSEMBLY	9-43
REASSEMBLY AND REMOUNTING	9-43
STEERING TENSION ADJUSTMENT	9-46
REAR WHEEL	9-47
CONSTRUCTION	9-47
REMOVAL	9-48
INSPECTION AND DISASSEMBLY	9-50
REASSEMBLY AND REMOUNTING	9-52
REAR SHOCK ABSORBER	9-57
CONSTRUCTION	9-57
REMOVAL	9-57
INSPECTION	9-58
REMOUNTING	9-58
SUSPENSION SETTING	9-58

REAR SWINGARM	9-59
CONSTRUCTION	9-59
REMOVAL	9-59
INSPECTION	9-60
REMOUNTING	9-61
FRONT BRAKE	9-63
CONSTRUCTION	9-63
BRAKE PAD REPLACEMENT	9-64
BRAKE FLUID REPLACEMENT	9-65
CALIPER REMOVAL AND DISASSEMBLY	9-66
CALIPER INSPECTION	9-67
CALIPER REASSEMBLY AND REMOUNTING	9-68
BRAKE DISC INSPECTION	9-70
MASTER CYLINDER REMOVAL AND DISASSEMBLY	9-70
MASTER CYLINDER INSPECTION	9-71
MASTER CYLINDER REASSEMBLY AND REMOUNTING	9-71
REAR BRAKE	9-73
CONSTRUCTION	9-73
BRAKE PAD REPLACEMENT	9-74
BRAKE FLUID REPLACEMENT	9-76
CALIPER REMOVAL AND DISASSEMBLY	9-76
CALIPER INSPECTION	9-78
CALIPER REASSEMBLY AND REMOUNTING	9-79
BRAKE DISC INSPECTION	9-83
MASTER CYLINDER REMOVAL AND DISASSEMBLY	9-83
MASTER CYLINDER INSPECTION	9-83
MASTER CYLINDER REASSEMBLY AND REMOUNTING	9-83
BRAKE LOCK ADJUSTMENT	9-84
BRAKE LOCK CABLE REPLACEMENT	9-85
BRAKE-LOCK SYSTEM	9-87
TIRE AND WHEEL	9-91
TIRE REMOVAL	9-91
INSPECTION	9-91
VALVE INSTALLATION	9-92
TIRE INSTALLATION	9-92
BALANCER WEIGHT INSTALLATION	9-93

EXTERIOR PARTS CONSTRUCTION

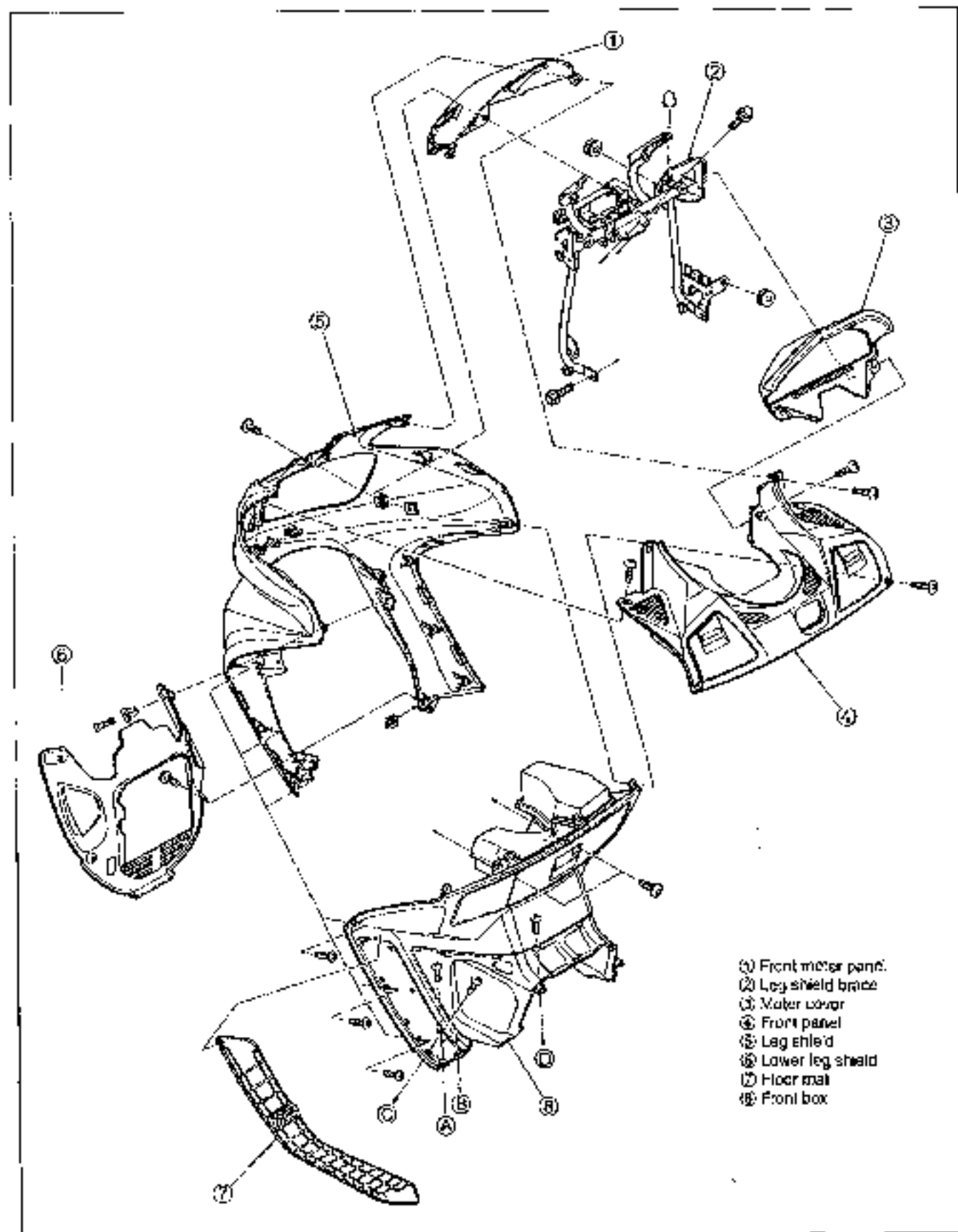

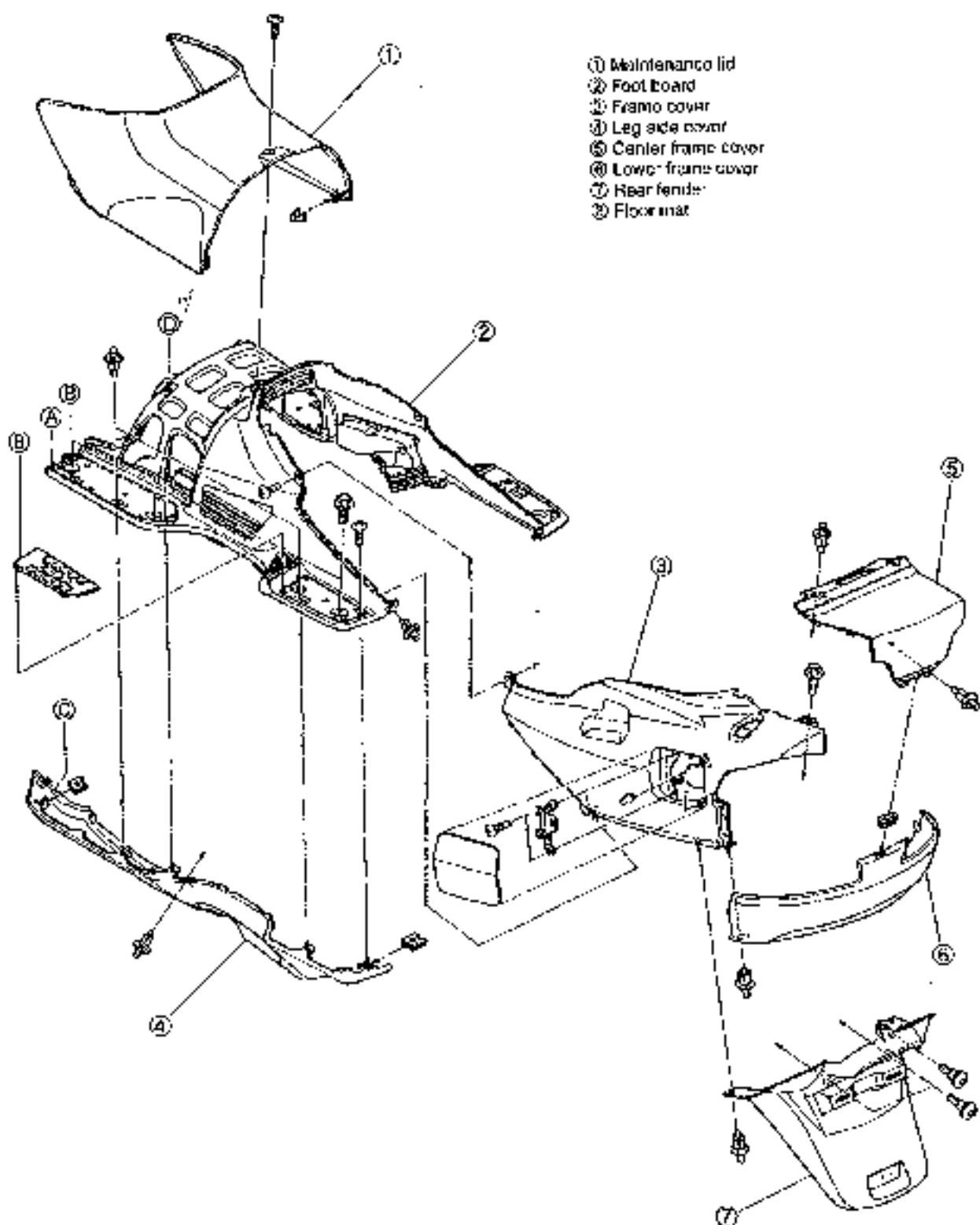

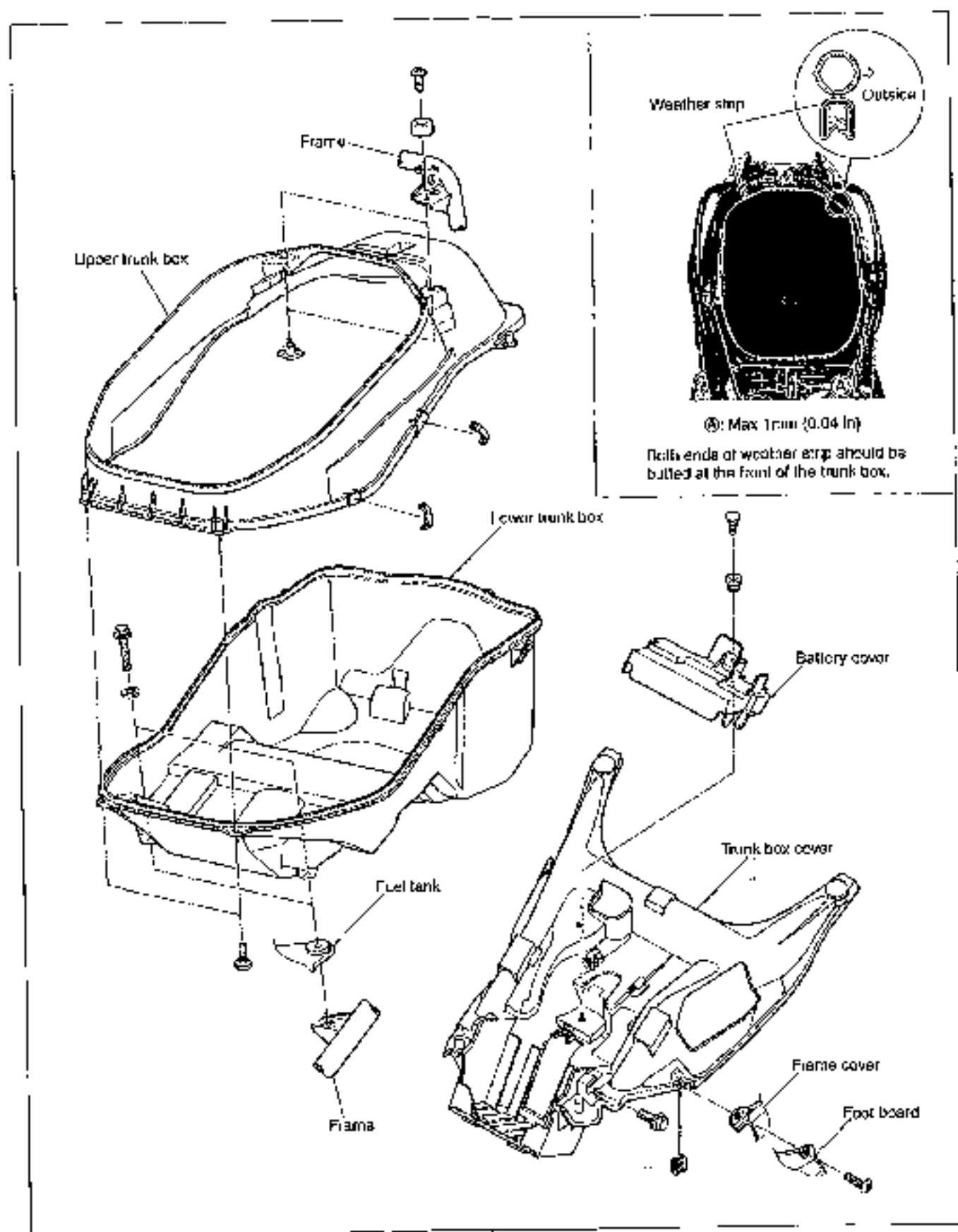

FRONT BOX

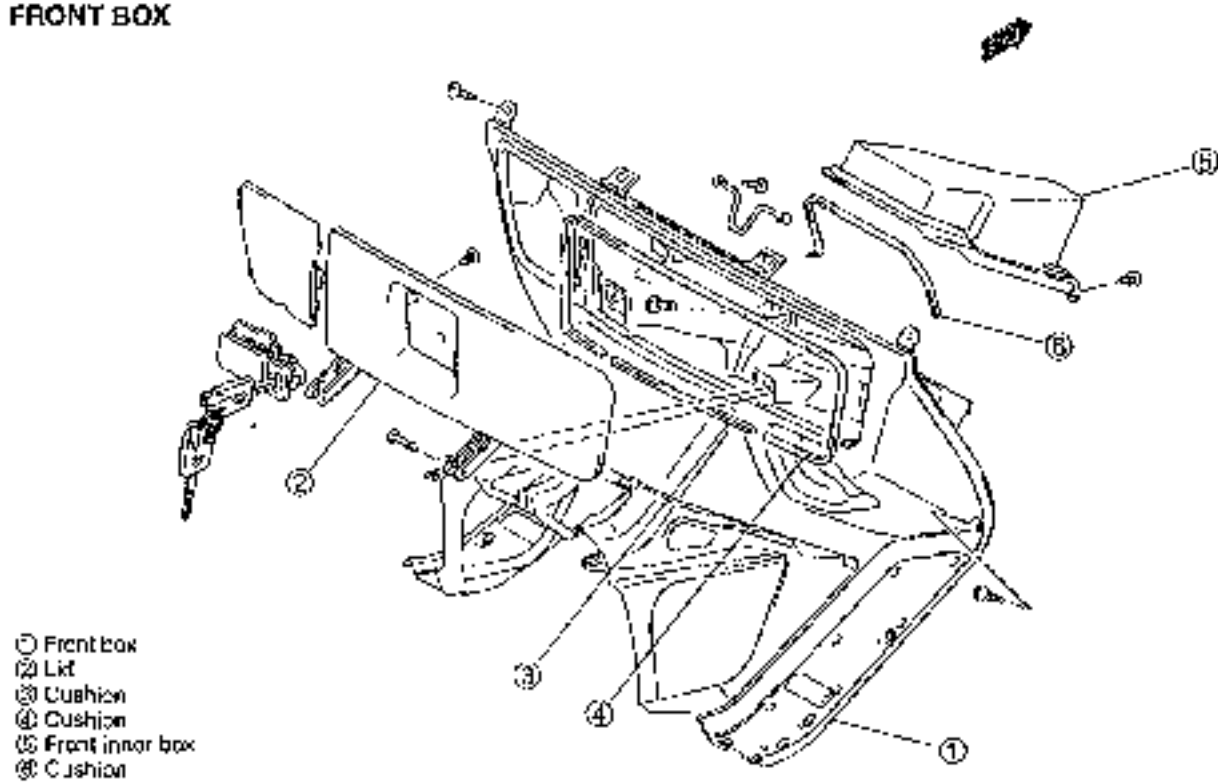

- ① Front box
- ② List
- ③ Cushion
- ④ Cushion
- ⑤ Front inner box
- ⑥ Cushion

FOOT BOARD ASSEMBLY

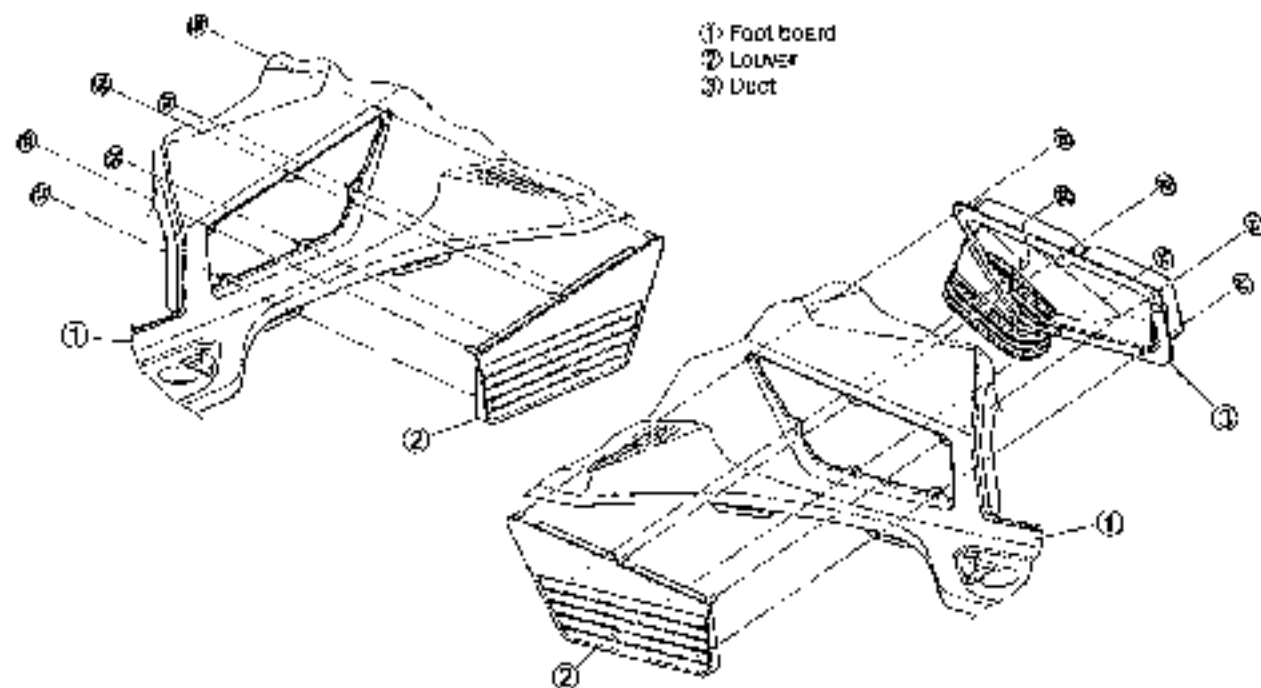

- ① Foot board
- ② Louver
- ③ Duct

REMOVAL

LOCATION OF EXTERIOR COMPONENTS

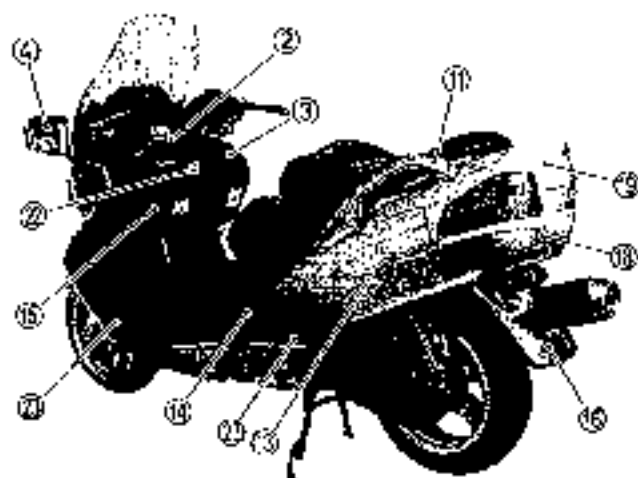
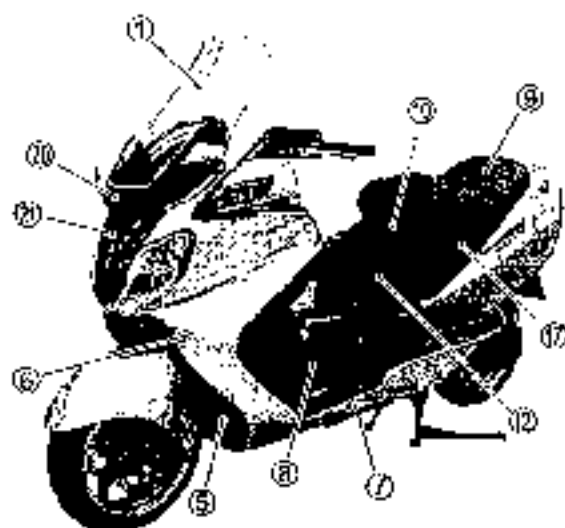

- ① Wind screen (C79-7)
- ② Handlebar cover (C79-9)
- ③ Front panel (C79-9)
- ④ Rear view mirror (right and left) (C79-9)
- ⑤ Lower leg shield (C79-10)
- ⑥ Leg shield (C79-10)
- ⑦ Leg side cover (right and left) (C79-11)
- ⑧ Maintenance lid (C79-13)

- ⑨ Seat (C79-13)
- ⑩ Seat damper (C79-14)
- ⑪ Pillion rider handle (right and left) (C79-15)
- ⑫ Trunk box cover (C79-16)
- ⑬ Frame cover (right and left) (C79-18)
- ⑭ Foot board (C79-18)
- ⑮ Front box (C79-18)
- ⑯ Rear fender (C79-20)

- ⑰ Trunk box (C79-20)
- ⑱ Lower frame cover (C79-15)
- ⑲ Center frame cover (C79-15)
- Ⓜ Wind screen cover (C79-7)
- Ⓨ Front leg shield cover (C79-11)
- Ⓩ Ignition switch (C79-19)
- ⓐ Floor mat (right and left)

REMOVAL PROCEDURE FLOW CHART

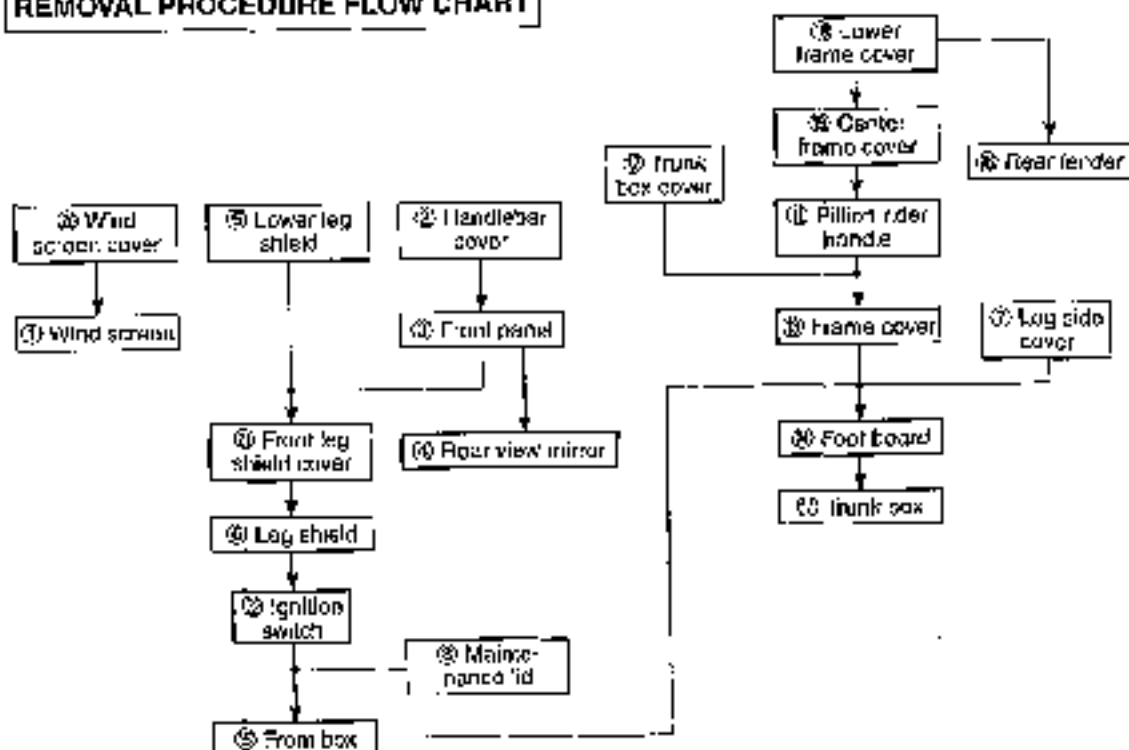

WIND SCREEN

- Remove the screws.



- Remove the wind screen cover ①.



☆: hooked part

- Remove the wind screen.



- Remove the wind screen brace ②.



HANDLEBAR COVER

- Remove the handlebar front cover (1).



- Remove the handlebar rear cover (2).



FRONT PANEL

- Remove the handlebar cover. (See above)
- Remove the screws.
- Remove the front panel.

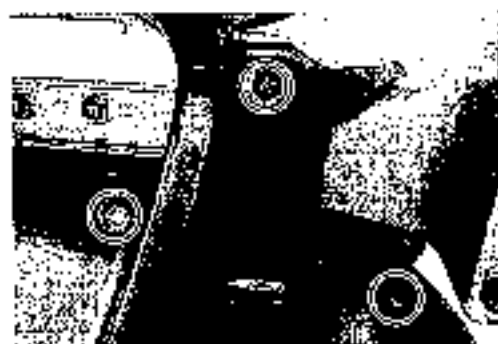
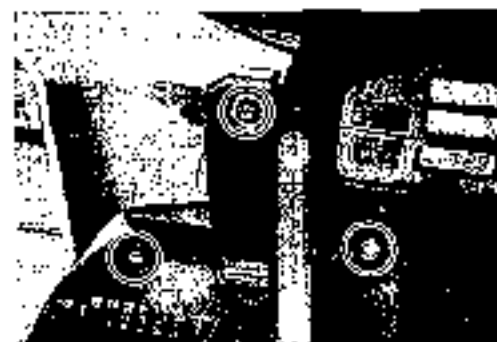

REAR VIEW MIRROR

- Remove the handlebar covers. (C7 9-8)
- Remove the front panel. (C7 9-8)
- Remove the bolts.
- Disconnect the turn signal coupler which is located under the combination meter.

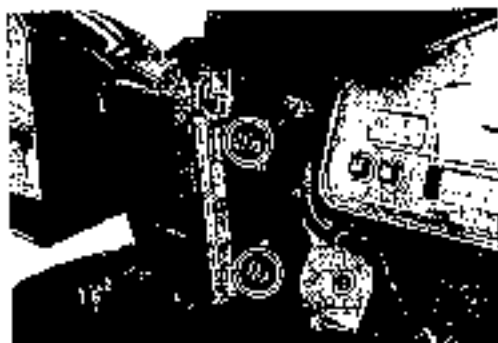

- Remove the screws.

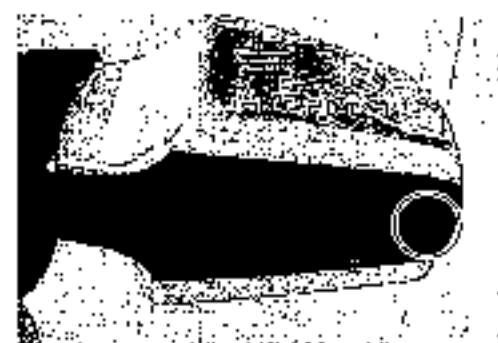

- Insert the screw driver into the hole (A).
- Pry the turn signal light out. (C7 10-32)



- Disconnect the turn signal coupler.



LOWER LEG SHIELD

- Disconnect the fasteners (1) by pulling the tab of fastener.
- Remove the screws.
- Remove the lower leg shield (2).

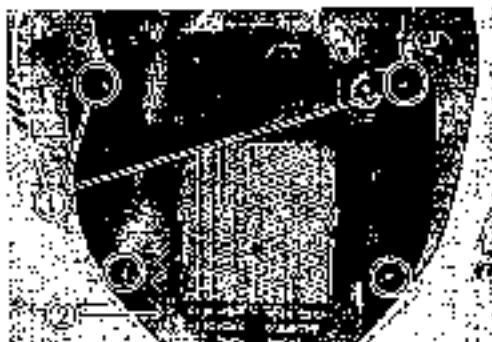

LEG SHIELD

- Remove the handlebar covers. (C-9-8)
- Remove the front panel. (C-9-8)
- Remove the lower leg shield. (C-9-8 above)
- Remove the screws.



- Remove the right/left floor mat.
- Remove the screws.



- Detach the insertings of the leg side covers.



- Remove the front leg shield cover (1).

△: hooked part



- Remove the screws.



- Disconnect the headlight couplers, ECM couplers and position light couplers (only E02, E19).
- Remove the leg shield.



RIGHT LEG SIDE COVER

- Remove the floor mats.
- Remove the screws and fasteners.
- Remove the right leg side cover by detaching the insertings.

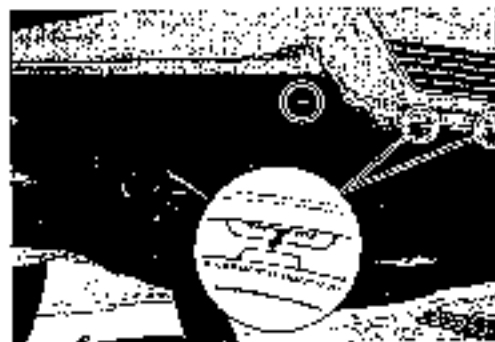
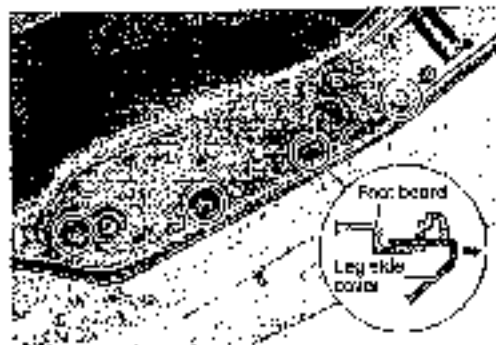
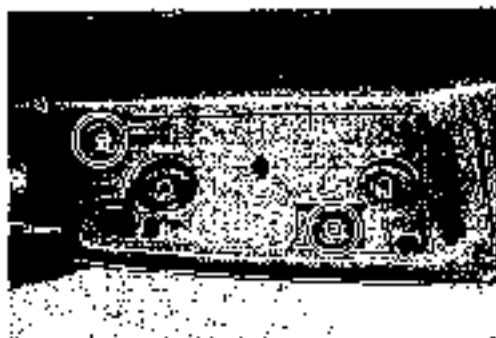

LEFT LEG SIDE COVER

- Remove the floor mats.
- Remove the screws and fasteners.
- Remove the left side cover by detaching the insertings.

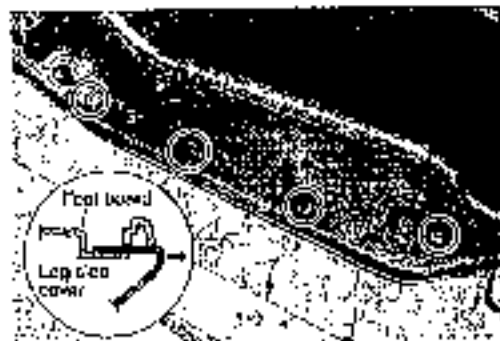

MAINTENANCE LID

- Remove the screw
- Detach the inserting (A) of maintenance lid.
- Remove the maintenance lid.

NOTE:

Cover the hatched areas in order to prevent the front box from getting damage.

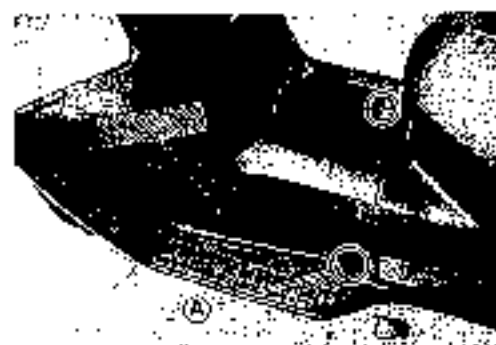
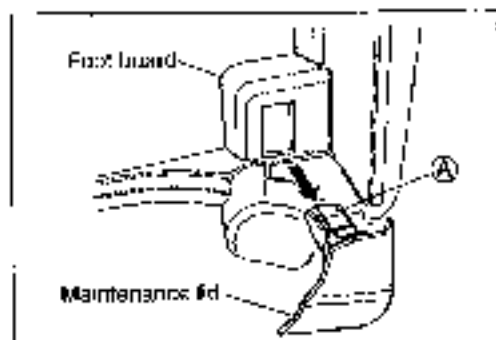
**SEAT**

- Lift the seat up.
- Remove the tool set
- Remove the battery cover (1).
- Remove the battery. (☞ 10-3)



- Disconnect the trunk light coupler (2).
- Disconnect the seat damper (☞ 9-14)



- Remove the seat by removing the nuts at the seat hinge



SEAT DAMPER

- Remove the right frame cover. (C7*9-18)
- Remove the clip (1), washer (2) and mounting bolt (3).
- Remove the seat damper (4).

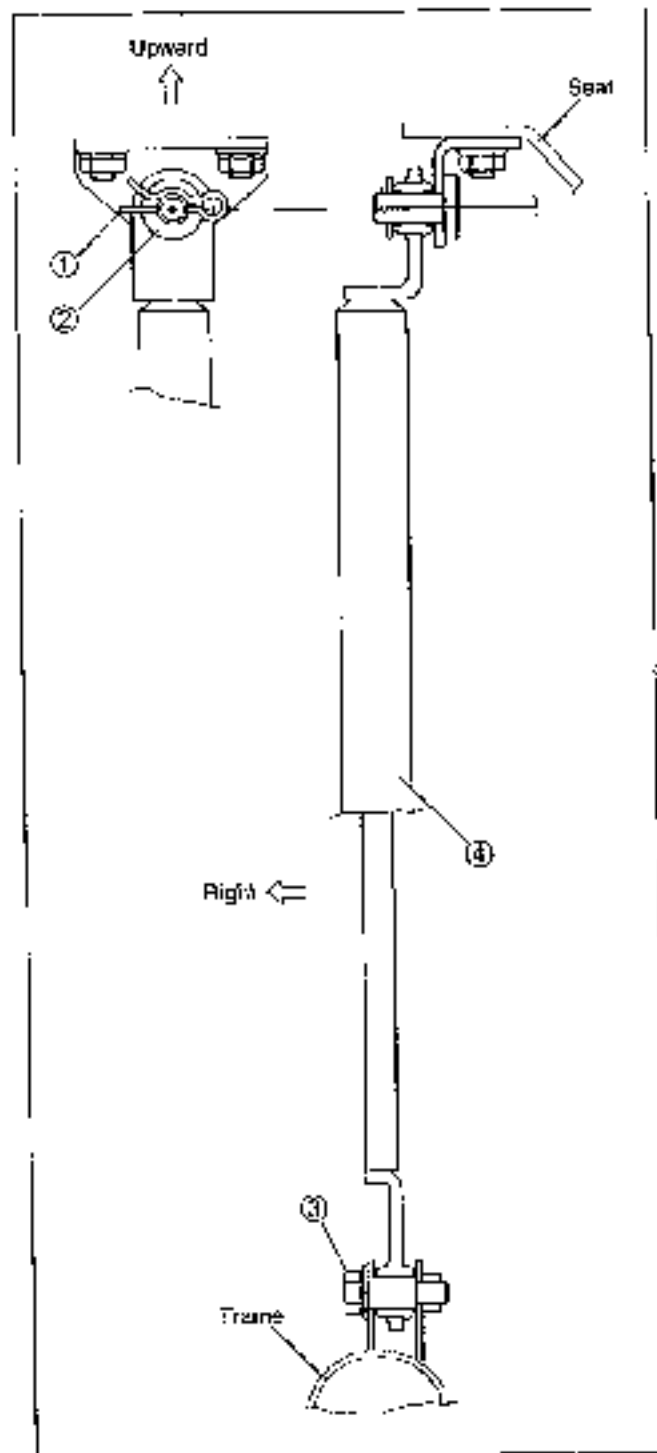

PILLION RIDER HANDLE

- Lift the seat up.
- Remove the lower frame cover ① by removing the fasteners.



- Remove the center frame cover ②.



- Remove the pillion rider handles ③.

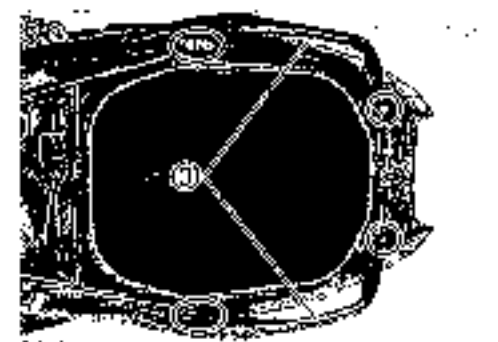

TRUNK BOX COVER

- Remove the battery cover (1).
- Remove the starter relay (2) and coupler (3) from the battery cover.
- Remove the battery. (C-7 10-3)



- Remove the trunk box cover (4).



FRAME COVER

- Remove the lower frame cover, center frame cover and pillion rider handles (1). (C-7 9-15)
- Remove the trunk box cover. (C-7 above)
- Remove the bolt and the fasteners.



- Remove the fuel tank cap (2).
- Remove the fuel inlet mounting screws.

NOTE:

When removing the screws, close the fuel cap in order to prevent the screws and washers from falling in the fuel inlet.



- Remove the screws.
- Remove the turn signal light socket and combination light socket.



- Remove the frame covers.
- Unclamp the harness in the back of the frame cover.

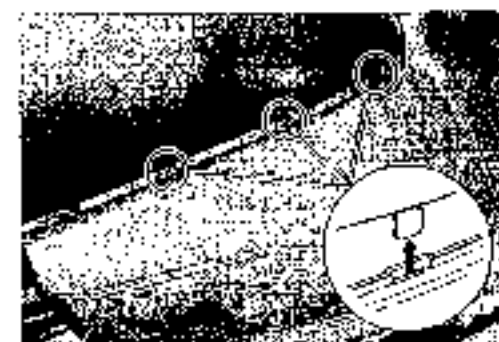

FOOT BOARD

- Remove the following parts.
 - Pillion rider handles (☐ 9-15)
 - Trunk box cover (☐ 9-16)
 - Frame covers (☐ 9-16)
 - Right/left leg side covers (☐ 9-12)
 - Front box (☐ 9-18)
- Remove the screws on the cooling duct.

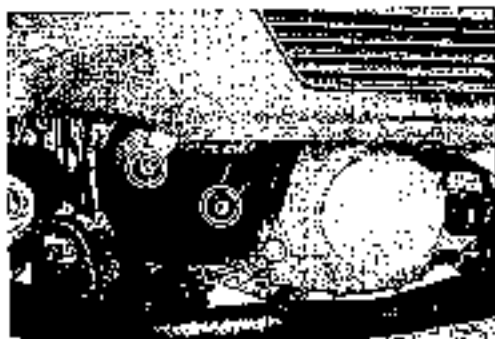

- Remove the foot board.

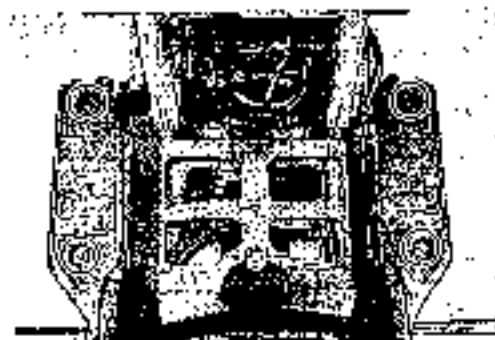

FRONT BOX

- Remove the following parts.
 - Maintenance lid (☐ 9-13)
 - Handlebar covers (☐ 9-8)
 - Front panel (☐ 9-8)
 - Log shield (☐ 9-10)
 - Screws in the box
- Disconnect the power source coupler.



- Pull the brake lock knob.
- Remove the brake lock knob ①.



- Remove the inner box ②.



- Remove the ignition switch ③ by using the special tools.

ROX 09930-11930: Torx bit JT30H
09930-11940: Bit holder

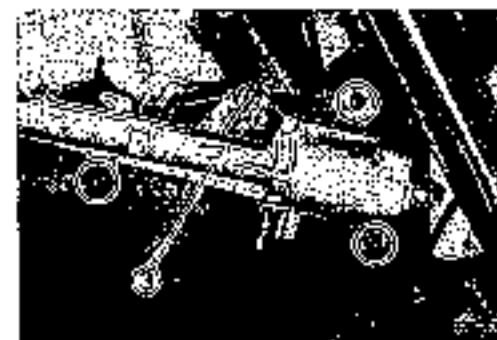

- Remove the screws.
- Remove the front box.



REAR FENDER

- Remove the lower frame cover (1).



- Remove the fasteners and bolts.
- Remove the rear fender (2).
- Disconnect the license light coupler.



TRUNK BOX

- Remove the following parts.
 - Seat (9-13)
 - Pillion rider handles (9-15)
 - Right/left frame covers (9-16)
 - Rear fender (above)
 - Foot board (9-18)
- Remove the rear frame brace (1).



- Remove the trunk light seat switch (2).



- Remove the seat lock (3).
- Remove the trunk box screws.

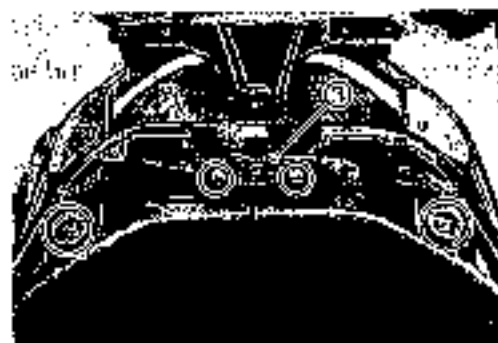

- Remove the muffler bracket (4).



- Remove the seat rail (5).



- Remove the trunk box (6).



LEG SHIELD BRACE

- Remove the wind screen and wind screen brace. (7-9-7)
- Remove the leg shield. (7-8-10)
- Remove the front meter panel (1) and the combination meter assembly.



- Remove the electrical parts from the leg shield brace
- Remove the mounting bolts



NOTE:

It is possible to remove the leg shield brace without removing the front box.



REMOUNTING

Remounting the exterior parts in the reverse order of removal. Pay attention to the following points:

SEAT RAIL

- Apply **THREAD LOCK SUPER "1360"** to the seat rail mounting bolts (only M10).

← **1360 999000-32130: THREAD LOCK SUPER "1360"**

- Tighten the seat rail mounting bolts to the specified torque.



6 Seat rail mounting bolt

(M8): 23 N·m (2.3 kgf-m, 16.5 lb-ft)

(M10): 50 N·m (5.0 kgf-m, 36.0 lb-ft)



HANDLEBAR COVER

After installing the handlebar covers, inspect clearance between the handlebar cover (1) and the front panel (2)/meter panel (3). If the clearance is less than 5 mm (0.2 in), adjust the handlebar position by rotating the handlebar so that the clearance would be more than 5 mm (0.2 in) all around the handlebar cover.

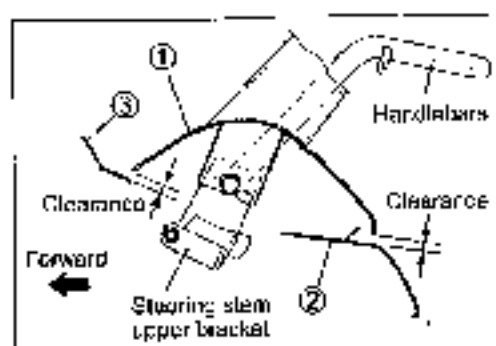

- Measure the clearance between the handlebar cover and the front panel/meter panel before removing the handlebar covers.
- Remove the handlebar covers (1-9-8).
- Loosen the handlebar clamp bolts (4).
- Rotate the handlebar according to the clearance measured above.

**NOTE:**

When rotating the handlebar by 0.5 mm (0.02 in) at the punch mark, the clearance would be varied as follows.

- Ⓐ 4.7 mm (0.19 in) at front end of handlebar cover
- Ⓑ 7.3 mm (0.29 in) at rear end of handlebar cover

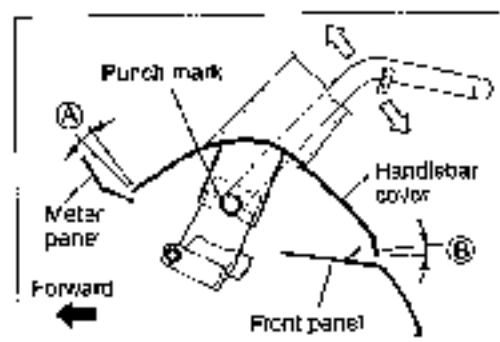

- Tighten the handlebar clamp bolts to the specified torque.

Ⓞ Handlebar clamp bolt: 23 N·m (2.3 kgf-m, 16.5 lb-ft)

- Install the handlebar covers.
- Inspect the clearance.

NOTE:

- First tighten the bolt (Ⓔ), and then tighten the bolt (Ⓞ).
- Because of above adjustment, it is possible that the punch mark on the handlebars is out of alignment with the mating surface of handlebar holder.

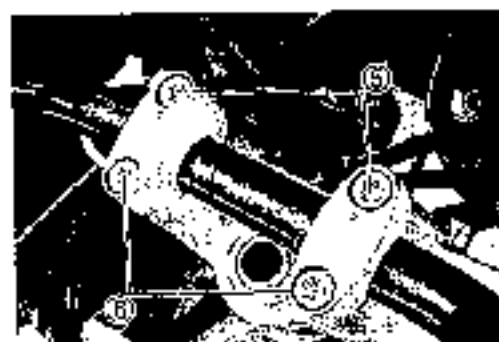

FRONT WHEEL CONSTRUCTION

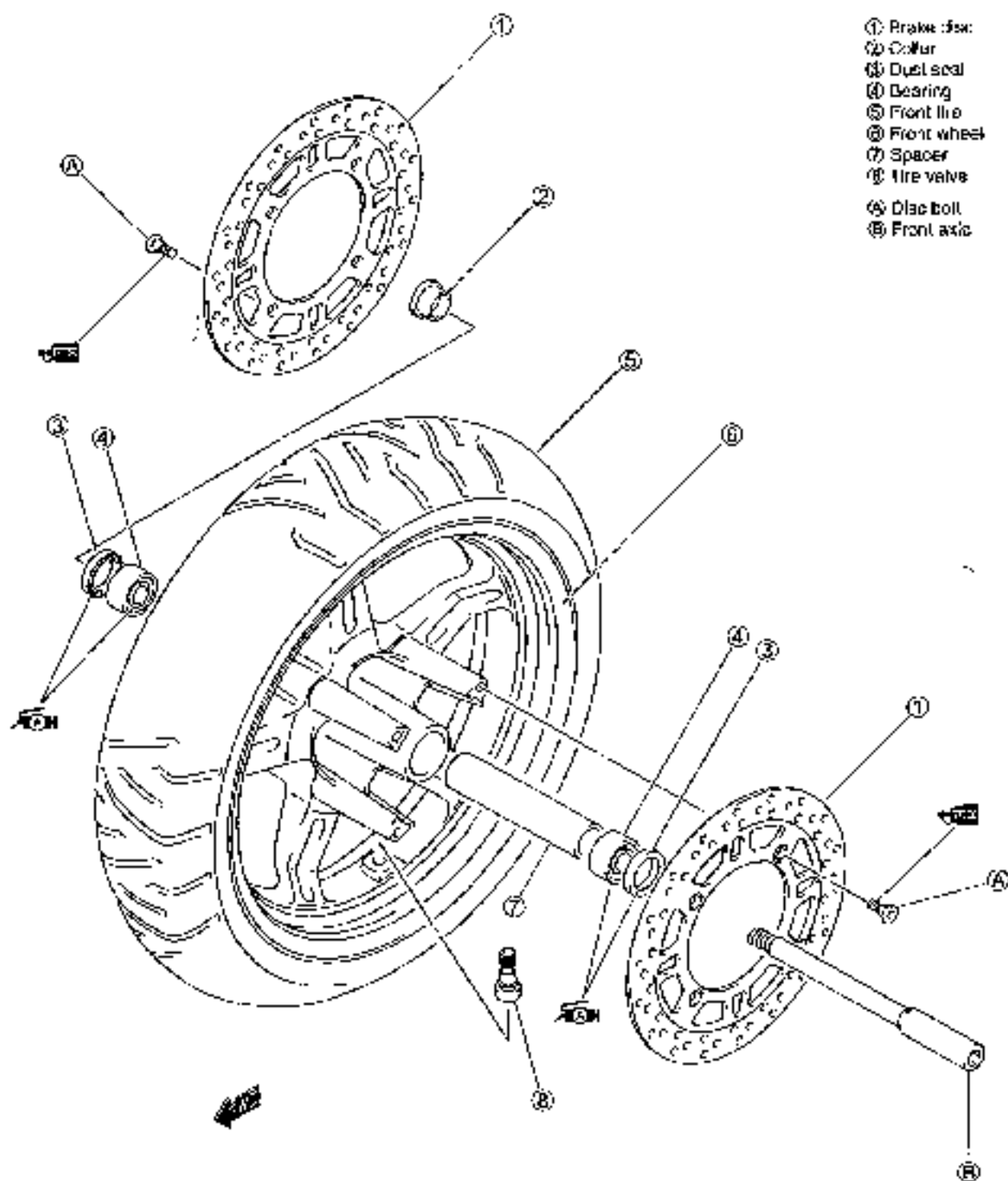

ITEM	N·m	kgf·m	lb-ft
(A)	23	2.3	16.6
(B)	65	6.5	47.0

REMOVAL

- Remove the right and left brake hose clamp bolts.



- Remove the right and left brake calipers.

NOTE:

- * Cover the front fender, especially hatched area (A), from damage.
- * Do not operate the brake lever while removing the caliper.



- Loosen the axle pinch bolt.
- Loosen the front axle with special tool.

 08900-18710: Hexagon socket (12 mm)



- Rise the front wheel off the ground and support the motorcycle with a jack or wooden block.

CAUTION:

Make sure that the motorcycle is supported securely.

- Remove the front axle and the front wheel.
- Remove the collar (1).

NOTE:

After removing the front wheel, tilt the calipers temporarily to the original positions.

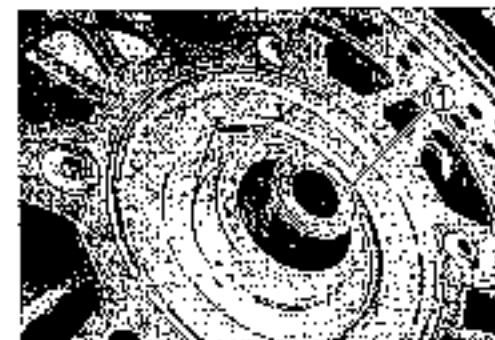

INSPECTION AND DISASSEMBLY

- Remove the discs.



DUST SEAL

Inspect the dust seal's lip for wear or damage.

If any damages are found, replace the dust seals with new ones.



- Remove the dust seals by using the special tool.

 09913-50121: Oil seal remover

CAUTION

Do not reuse the removed dust seals.



FRONT AXLE

Using a dial gauge, check the front axle for runout and replace it if the runout exceeds the limit.

 09900-20607: Dial gauge (1/100)
09900-20701: Magnetic stand
09900-21304: V-block set (100 mm)

DATA Axle shaft runout
Service Limit: 0.25 mm (0.010 in)

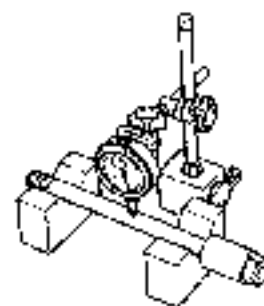

WHEEL

Make sure that the wheel runout checked as shown does not exceed the service limit. An excessive runout is usually due to worn or loosened wheel bearings and can be reduced by replacing the bearings. If bearing replacement fails to reduce the runout, replace the wheel.

(Wheel inspection: (C/F 8-91))

DATA Wheel runout
Service Limit (Axial and Radial): 2.0 mm (0.08 in)

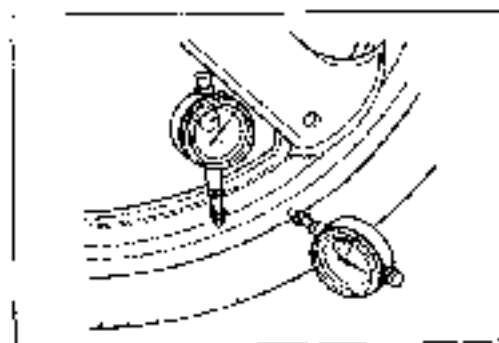

WHEEL BEARING

Inspect the play of the wheel bearings by finger while they are in the wheel. Rotate the inner race by finger to inspect for abnormal noise and smooth rotation.

Replace the bearing in the following procedure if there is anything unusual

- Remove the wheel bearings by using the special tool.

 09921-20240: Bearing remover set

CAUTION

Do not reuse the removed bearings.

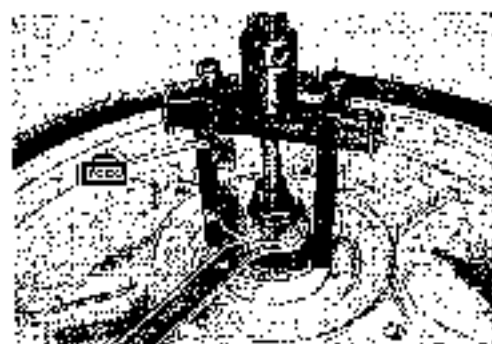
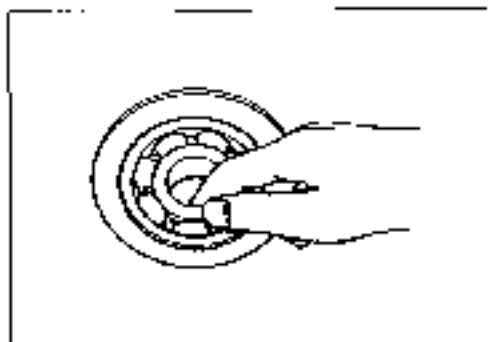

REASSEMBLY AND REMOUNTING

Reassemble and remount the front wheel in the reverse order of removal and disassembly. Pay attention to the following points:

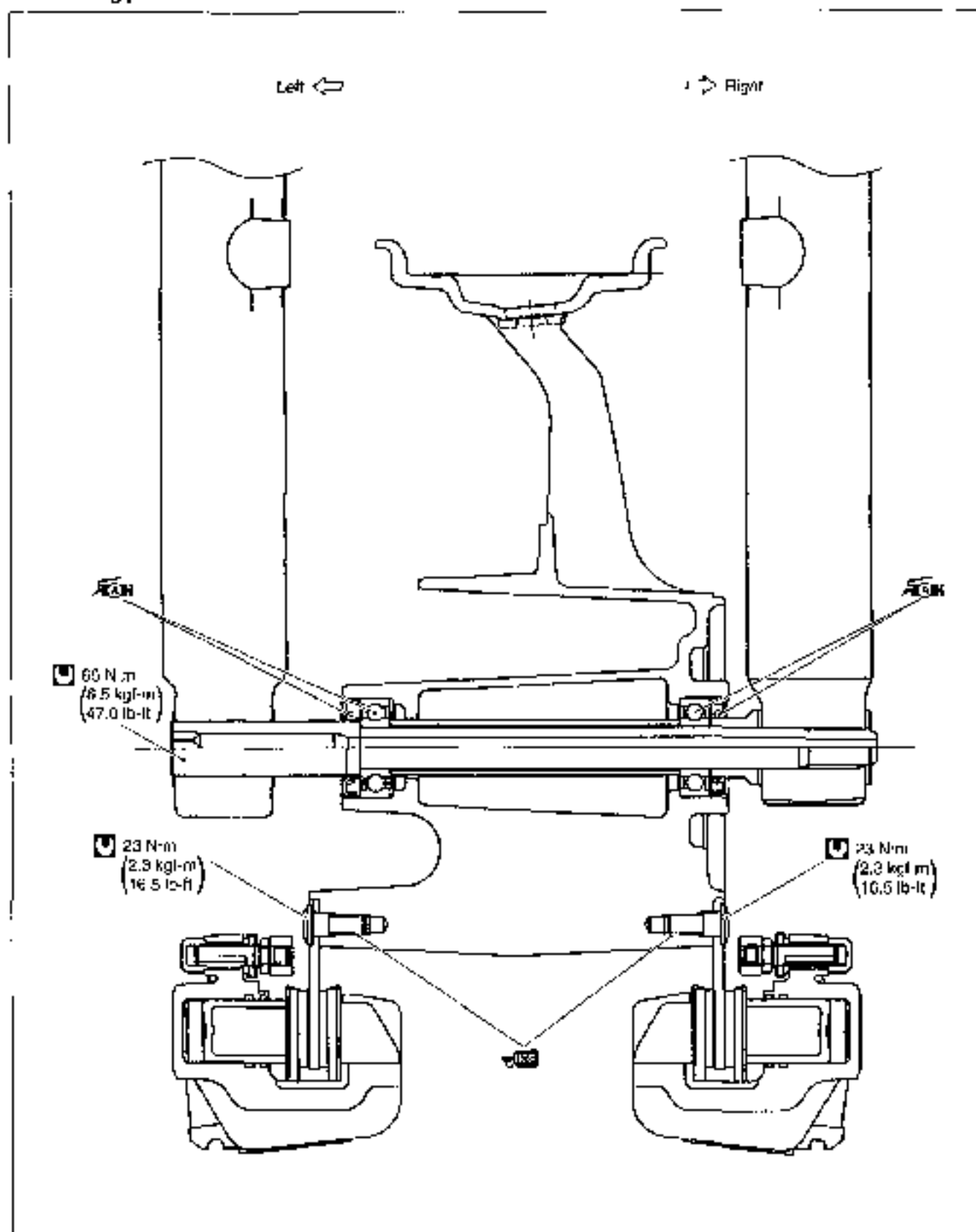

WHEEL BEARING

- Apply grease to the wheel bearings.

 99000-25010: SUZUKI SUPER GREASE "A"

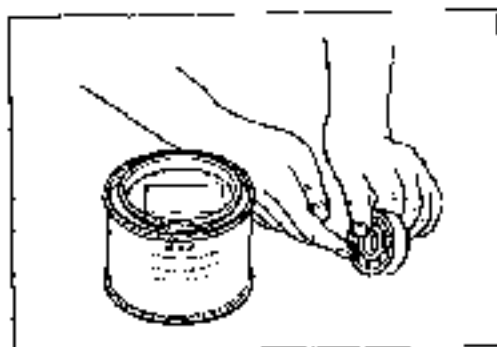

- First install the right wheel bearing, then install the left wheel bearing and spacer by using the special tools.

 09941-34513: Bearing/Steering race installer set
09913-70210: Bearing installer set

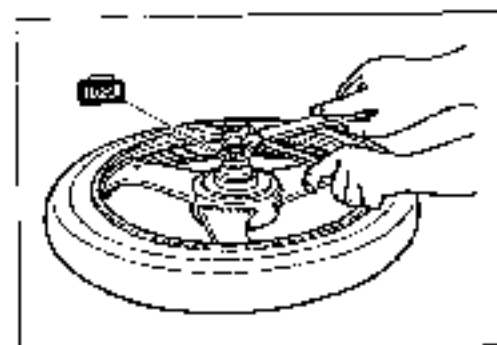

CAUTION

The sealed cover of the bearing must face outside.

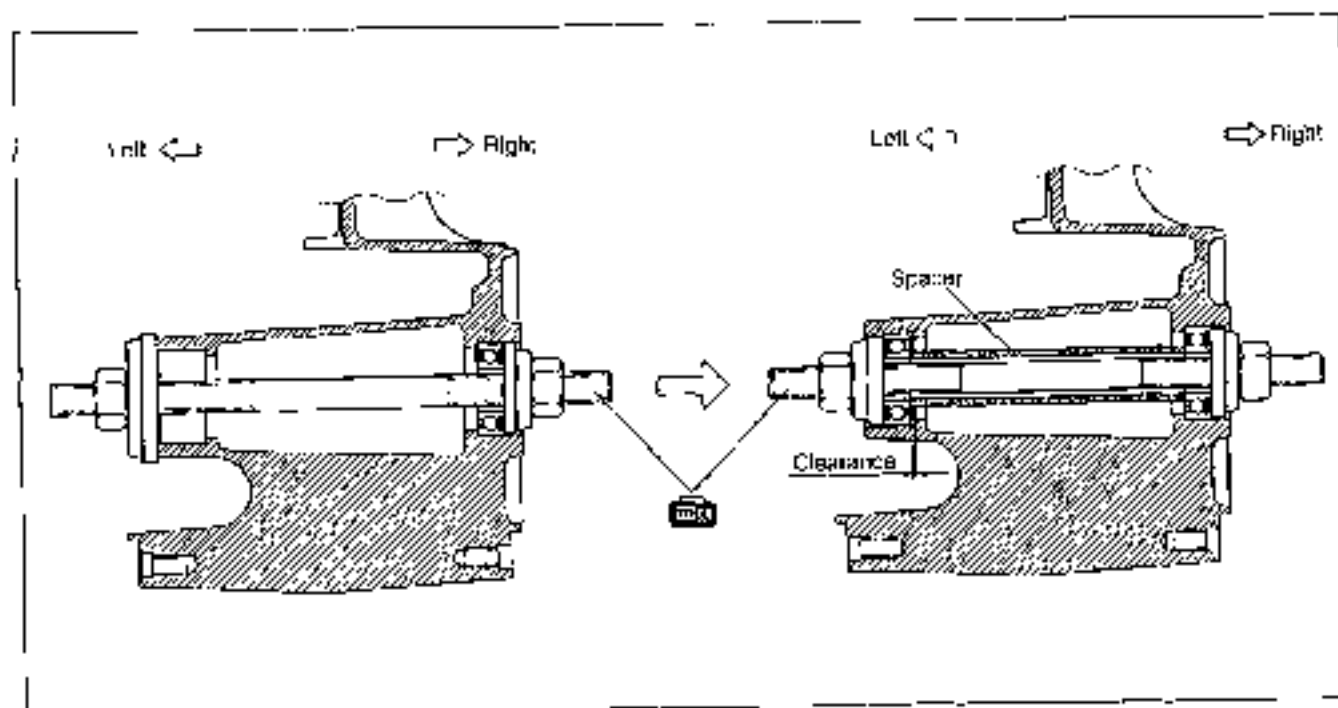

BRAKE DISC

Make sure that the brake disc is clean and free of any greasy matter.

- Apply THREAD LOCK SUPER "1360" to the disc mounting bolts and tighten them to the specified torque.

 Brake disc bolt: 23 N·m (2.3 kgf·m, 16.5 lb-ft)

 99000-32130: THREAD LOCK SUPER "1360"



DUST SEAL

- Apply SUZUKI SUPER GREASE "A" to the dust seals.

 99000-25010: SUZUKI SUPER GREASE "A"

- Install the dust seals to the wheel.

NOTE:

The spring  of dust seal must face to the bearing.

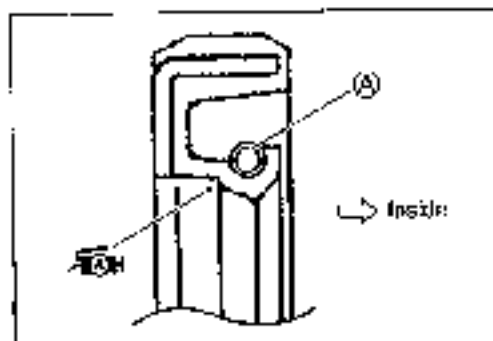
**FRONT AXLE**

- Install the front wheel and front axle.
- Tighten the front axle to the specified torque with special tool.

 09200-18710: Hexagon socket 12 mm

 Front axle: 65 N·m (6.5 kgf-m, 47.0 lb-ft)

NOTE:

* Before tightening the two axle pinch bolt on the left front fork leg, move the front fork up and down 4 or 5 times without applying front brake.

* Make sure that the arrow on the tire side wall points to the wheel rotation. ( 9-33)

- Tighten axle pinch bolt on the left front fork leg to the specified torque.

 Front axle pinch bolt: 23 N·m (2.3 kgf-m, 16.5 lb-ft)

**BRAKE CALIPER**

- Tighten the brake caliper mounting bolts to the specified torque.

 Front brake caliper mounting bolt:
26 N·m (2.6 kgf-m, 19.0 lb-ft)

NOTE:

* Push the pistons all the way into the caliper and remount the callipers.

* After installing the wheel, pump the brake lever several times in order to operate the brake correctly.



FRONT FORK CONSTRUCTION

- ① O-ring
- ② Spacer
- ③ Washer
- ④ Spring
- ⑤ Piston ring
- ⑥ Cylinder
- ⑦ Recumbent spring
- ⑧ Inner tube
- ⑨ Dust seal
- ⑩ Stopper ring
- ⑪ Oil seal
- ⑫ Retainer
- ⑬ Guide metal
- ⑭ Slice metal
- ⑮ Oil lock piece
- ⑯ Fork cover
- ⑰ Outer tube
- ⑱ Gasket

- Ⓐ Fork cap bolt
- Ⓑ Axle pinch bolt
- Ⓒ Cylinder bolt

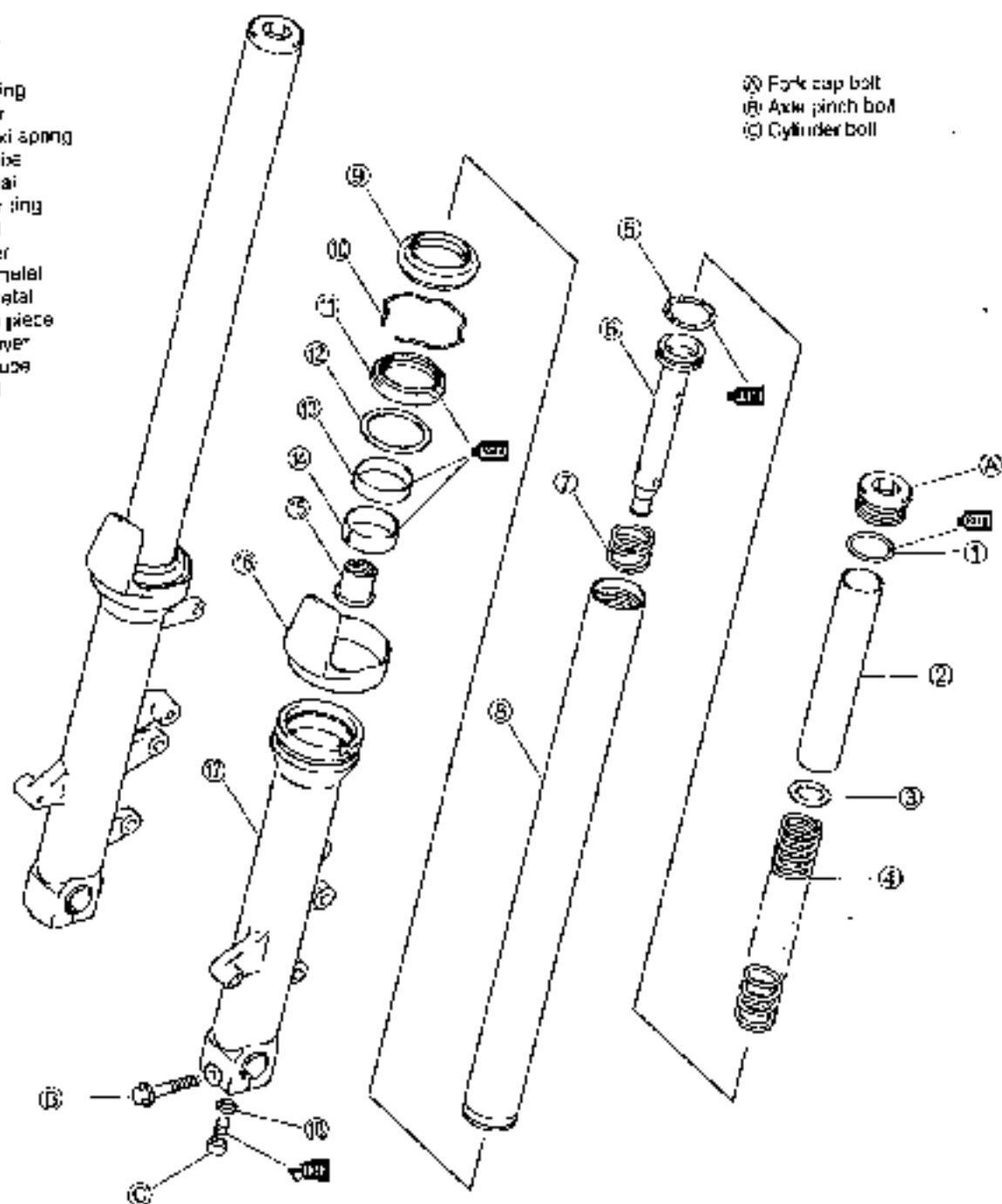

Ⓒ

ITEM	N·m	kgf·m	lb-ft
Ⓐ	25	2.9	16.5
Ⓑ	23	2.3	16.5
Ⓒ	30	3.0	21.5

REMOVAL AND DISASSEMBLY

- Remove the handlebar cover. (☞ 9-8)
- Remove the front panel. (☞ 9-6)
- Remove the front wheel. (☞ 9-26)
- Remove the front fender.

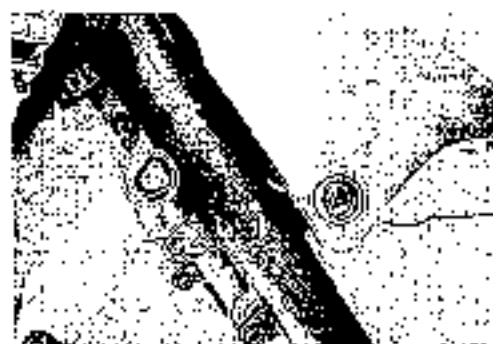

- Loosen the front fork upper clamp bolt (1).

NOTE:

Slightly loosen the front fork cap bolt (2) before loosening the lower clamp bolts to facilitate later disassembly.



- Loosen the front fork lower clamp bolts.

NOTE:

Hold the front fork by the hand to prevent sliding out of the steering stem.



- Remove the front fork cap bolt (3) with the special tool.

 09940-30230: Socket hexagon (17 mm)

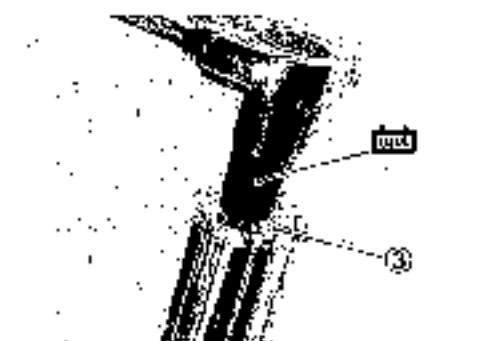

- Remove the spacer (4), washer (5) and spring (6).

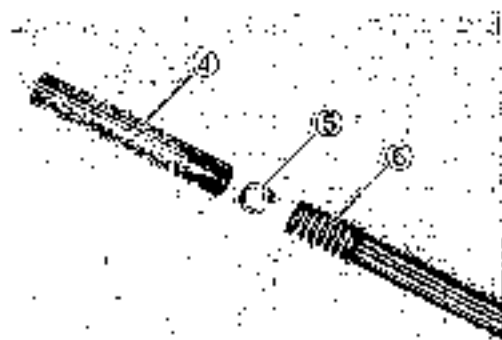

- Invert the fork and drain the fork oil out of the fork by stroking.
- Hold the fork inverted for a few minutes to drain oil.



- Remove the cylinder bolt (7).

NOTE:

If the cylinder turns together with the cylinder bolt, temporarily install the fork spring, spacer, washer and cap bolt to prevent the cylinder from turning.

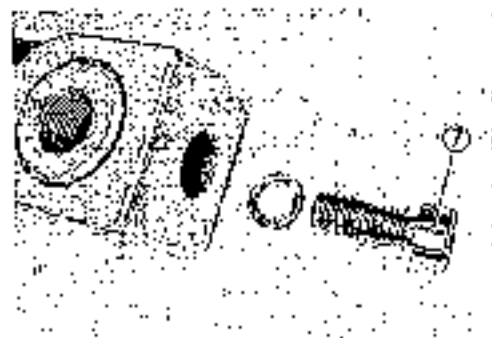

- Remove the cylinder (8) and rebound spring (9).

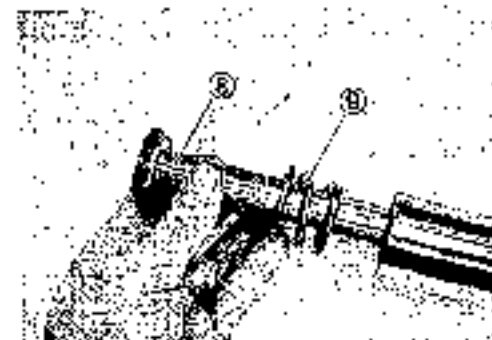

- Remove the dust seal.
- Remove the oil seal stopper ring.

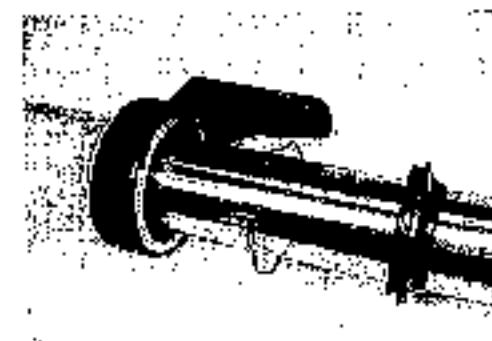

- Pull the inner tube out of the outer tube.

NOTE:

Be careful not to damage the inner tube.

CAUTION

The slide metal, guide metal, oil seal and dust seal must be replaced with the new ones when reassembling the front fork.

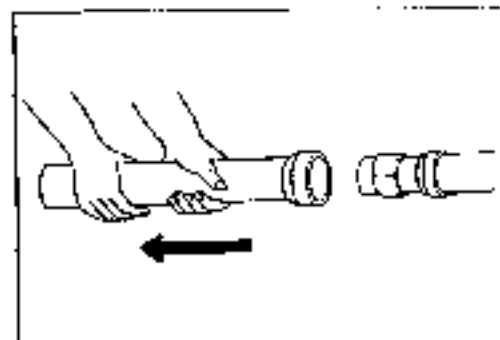

- Remove the following parts.

- (10) Oil seal
- (11) Oil seal retainer
- (12) Guide metal
- (13) Slide metal
- (14) Oil lock piece

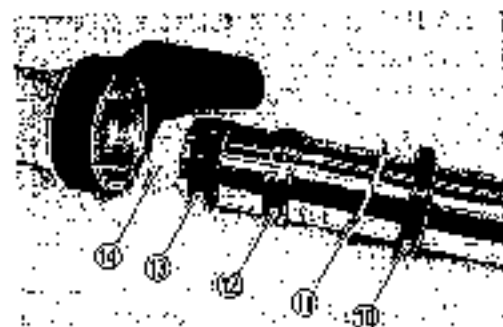
**INSPECTION****INNER AND OUTER TUBES**

Inspect the inner tube outer surface and the outer tube inner surface for scratches. If any defects are found, replace them with the new ones.

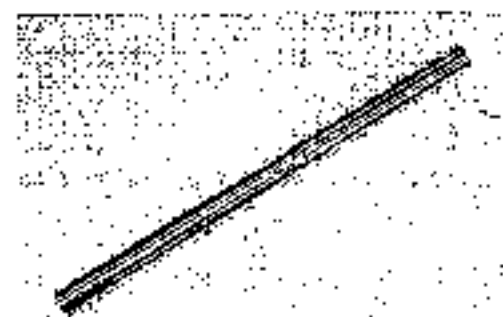
**FORK SPRING**

Measure the fork spring free length. If it is shorter than the service limit, replace it with a new one.

- DATA** Front fork spring free length
Service limit: 341 mm (13.42 in)



CYLINDER

Inspect the cylinder and piston ring (1) for damage. If any defects are found, replace them with new ones.

**REASSEMBLY AND REMOUNTING**

Reassemble and remount the front fork in the reverse order of removal and disassembly. Pay attention to the following points:

METALS AND SEALS

- Hold the inner tube vertically and clean the metal groove and install the guide metal by hand as shown.

CAUTION

- Use special care to prevent damage to the "Teflon" coated surface of the guide metal when mounting it.
- When installing the oil seal to inner tube, be careful not to damage the oil seal lip.
- Replace the removed metals and seals with new ones.
- Apply fork oil to the Anti-friction metals and lip of the oil seal.

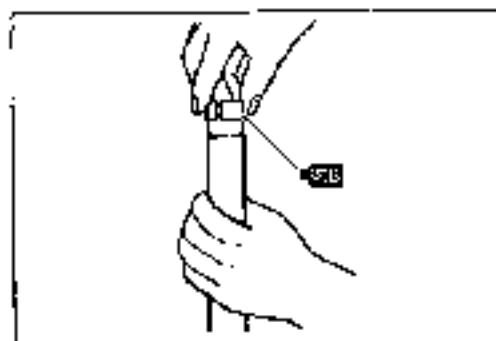

- Apply fork oil to the oil seal lip lightly before installing it.
- Assemble the following parts as shown.
 - ① Oil seal
 - ② Oil seal retainer
 - ③ Guide metal
 - ④ Slide metal

NOTE:

Stamped mark on the dust seal must face upward.

- Install the spring (5) into the oil lock piece (6) securely.

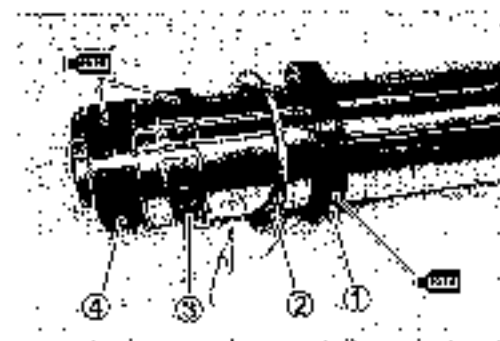

- Install the oil lock piece into the inner tube.
- Install the inner tube into the outer tube with care not to drop the oil lock piece out.

NOTE:

After installing the inner tube into the outer tube, keep the oil lock piece into the inner tube by compressing the front fork fully.

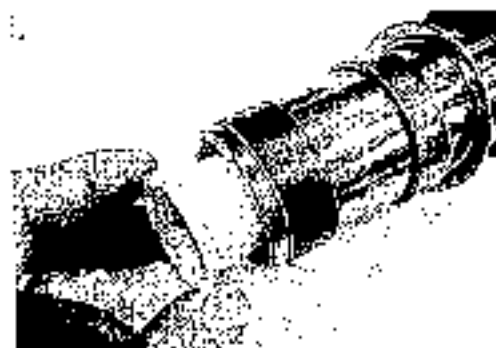

- Install the guide metal, the retainer and the oil seal into the outer tube with special tool.

 09940-52861: Front fork oil seal installer

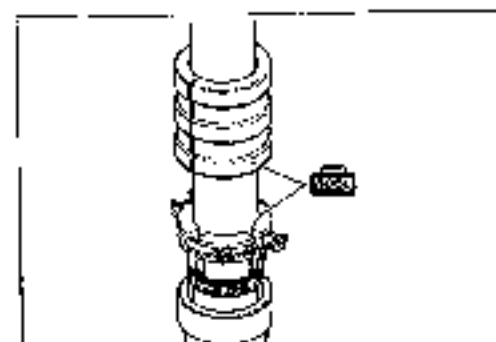

- Install the oil seal stopper ring (7) and the dust seal (8).

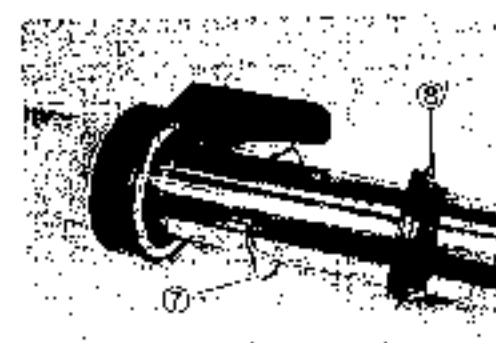

- (A) Dust seal
- (B) Oil seal stopper ring
- (C) Oil seal
- (D) Oil seal retainer
- (E) Guide metal

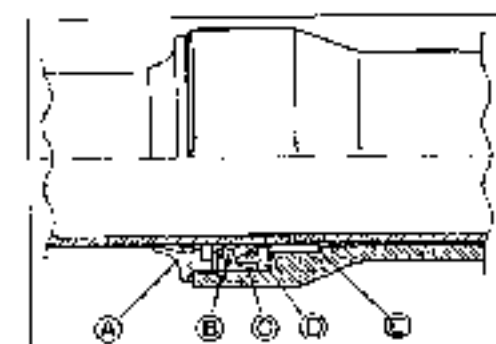
**CYLINDER BOLT**

- Install the rebound spring to the cylinder
- Install the cylinder into the front fork



- Apply THREAD LOCK "1342" to the cylinder bolt and tighten it to the specified torque.

PART 99000-32050: THREAD LOCK "1342"

Q Cylinder bolt: 30 N·m (3.0 kgf-m, 21.5 lb-ft)

CAUTION

Use a new gasket (2) to prevent oil leakage.

NOTE:

- * If the cylinder turns together with the cylinder bolt, temporarily install the fork spring, spacer, washer and cap bolt to prevent the cylinder from turning.
- * Check the front fork for smoothness by stroking it after installing the cylinder.

FORK OIL

- Place the front fork vertically without spring.
- Compress the front fork fully.
- Pour the specified front fork oil into the front fork.

PART 99000-99044-10G: SUZUKI FORK OIL #10

DATA Front fork oil capacity (each leg):
482 ml (16.29/16.97 US/Imp oz)

- Move the inner tube up and down several strokes until no more bubbles come out from the oil.
- Keep the front fork vertically and leave it during 5 – 6 minutes.

NOTE:

Take extreme attention to pump out air completely.

- Hold the front fork vertically and adjust the fork oil level with the special tool.

NOTE:

When adjusting the fork oil level, remove the fork spring and compress the inner tube fully.

TOOL 09943-74111: Front fork oil level gauge

DATA Fork oil level: 129 mm (5.08 in)

PART 99000-99044-10G: SUZUKI FORK OIL #10

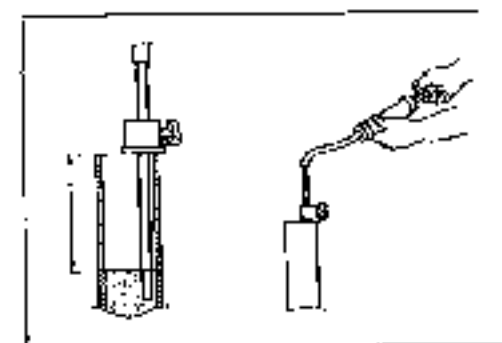
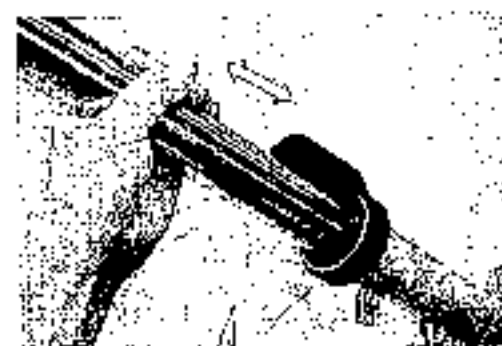
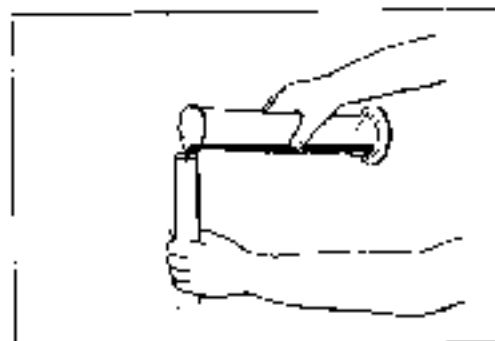
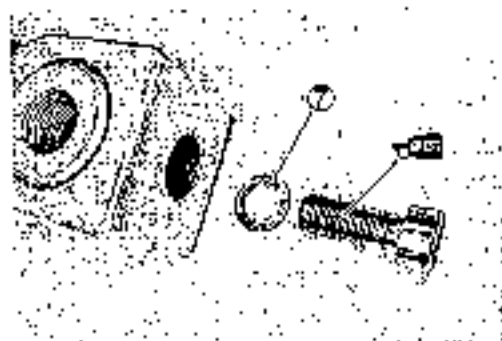

FORK SPRING

- Install the fork spring into the front fork.
- Install the washer (1) and the spacer (2).

NOTE:

The smaller spring pitch end must face upward.

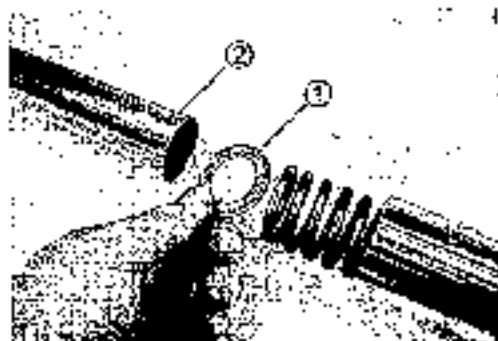
**FRONT FORK CAP BOLT**

- Apply fork oil lightly to the O-ring.

CAUTION

Use a new O-ring to prevent oil leakage.

- Tighten the front fork cap bolt temporarily.

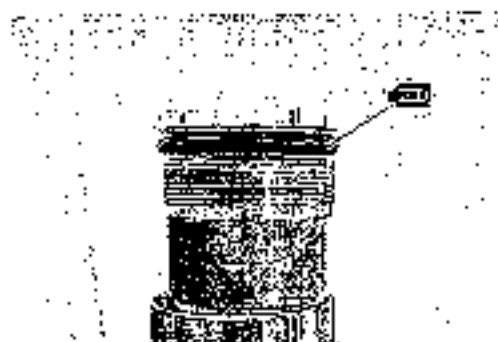

- Set the front fork to the front fork lower bracket temporarily by tightening the lower clamp bolts.
- Tighten the front fork cap bolt (1) to the specified torque with the special tool.

U Front fork cap bolt: 23 N·m (2.3 kgf-m, 16.5 lb-ft)

TOXU 08940-30230: Socket hexagon (17 mm)

- Align the top of the inner tube with the upper surface of the steering stem upper bracket.
- Tighten the front fork upper and lower clamp bolts.

U Front fork upper clamp bolt: 23 N·m (2.3 kgf-m, 16.5 lb-ft)
Front fork lower clamp bolt: 23 N·m (2.3 kgf-m, 16.5 lb-ft)



- Install the front fender
- Install the front wheel and brake calipers. (C/P 9-31)

NOTE:

After install the brake calipers, front brake should be efficient by pumping the front brake lever.

STEERING AND HANDLEBARS CONSTRUCTION

- (1) Handlebar clamp
- (2) Steering stem upper bracket
- (3) Dust seal
- (4) Upper bearing
- (5) Lower bearing
- (6) Steering stem lower bracket
- (7) Dust seal

- (8) Handlebar clamp bolt
- (9) Upper clamp nut
- (10) Lower clamp nut
- (11) Steering stem head nut

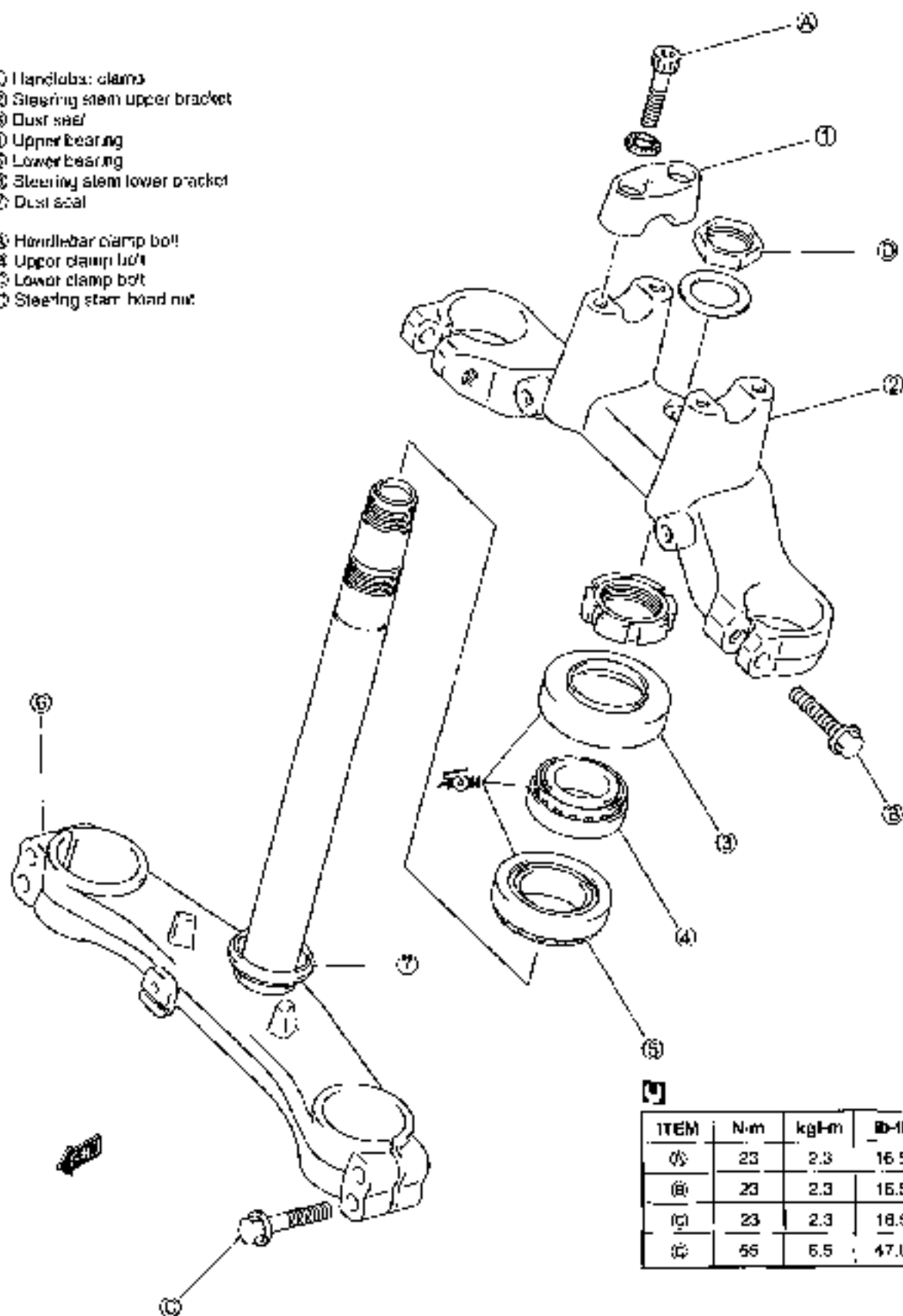

REMOVAL

HANDLEBARS

- Remove the handlebar covers. (C/F 9-8)
- Remove the right switch box (1).
- Disconnect the brake switch coupler.
- Remove the front brake master cylinder (2).

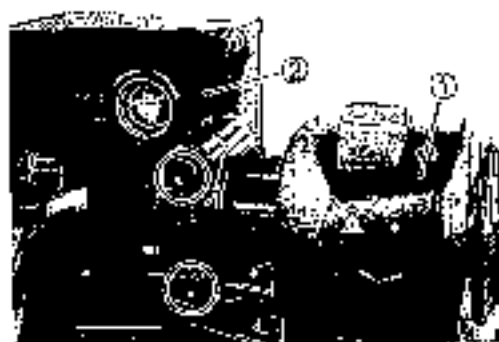

- Remove the left switch box (3).
- Disconnect the brake switch coupler.
- Remove the rear brake master cylinder (4).



- Remove the handlebars.

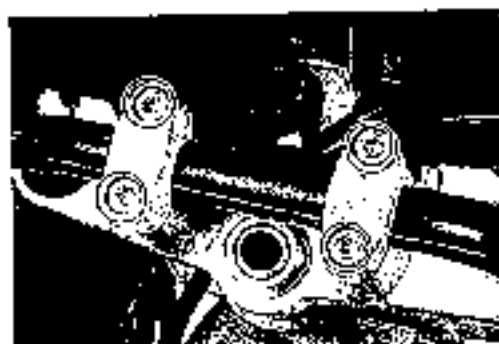

STEERING STEM

- Remove the front panel. (C/F 9-8)
- Remove the front fork. (C/F 9-33)
- Remove the cable/harness guide (1).
- Remove the brake hose clamp (2).

NOTE:

Before removing the handlebars, loosen the steering stem head nut to facilitate later disassembly.



- Remove the steering stem lower cover.

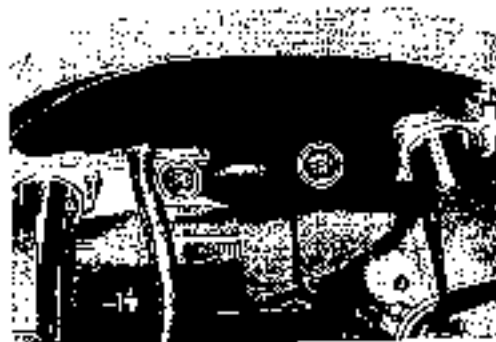

- Remove the brake hose clamp (3).
- Remove the front brake assembly.

CAUTION

Take care not to make air come in the front brake system.

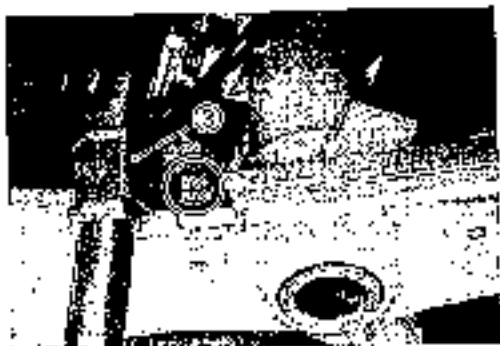

- Remove the steering stem upper bracket.



- Remove the steering stem nut with the special tool.

 09940-14911: Steering socket wrench

- Remove the steering stem lower bracket.

NOTE:

When loosening the stem nut, hold the steering stem lower bracket to prevent it from falling.



- Remove the dust cover (4) and bearing (5).



INSPECTION AND DISASSEMBLY

Inspect the removed parts for the following abnormalities.

- Handlebars distortion
- Race wear and brinelling
- Bearing wear or damage
- Abnormal bearing noise
- Distortion of the steering stem

If any abnormal points are found, replace defective parts with the new ones.

- Remove the steering stem lower bearing and dust seal using a chisel.

CAUTION

The removed bearing inner race and dust seal must be replaced with the new ones.

- Drive out the steering stem upper and lower bearing races using the special tools.

- 09941-54911: Bearing outer race remover
- 09941-74911: Steering bearing installer

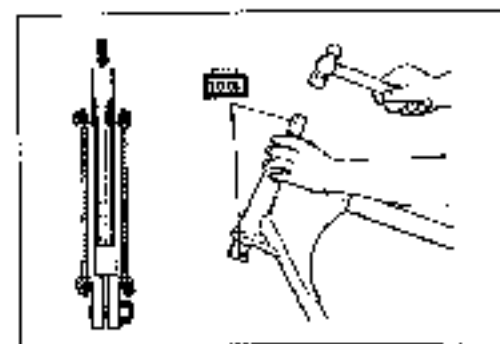
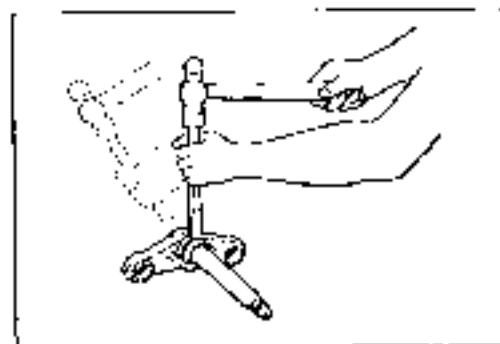

REASSEMBLY AND REMOUNTING

Reassemble and remount the steering stem in the reverse order of removal and disassembly. Pay attention to the following points:

BEARING RACES

- Press in the upper and lower outer races using the special tool.

- 09941-34513: Steering outer race installer

BEARINGS

- Press in the lower bearing and dust seal using the special tool.

- 09941-18011: Steering bearing installer

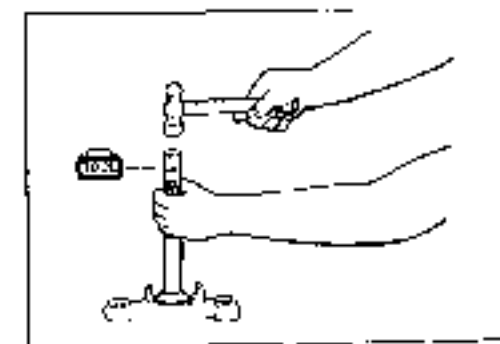
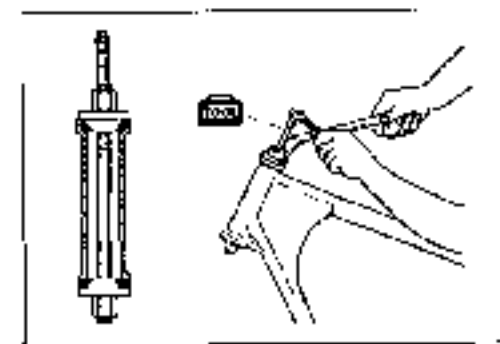

- Apply grease to the bearings, dust cover and dust seal.
- Install the upper bearing and the dust cover onto the frame.

 99000-25010: SUZUKI SUPER GREASE "A"

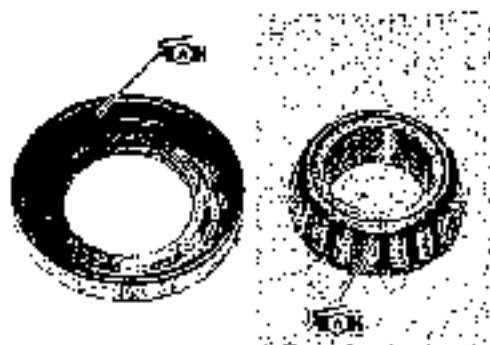

STEERING STEM

- Tighten the steering stem nut to the specified torque with the special tool.

 09940-14911: Steering stem nut wrench

 Steering stem nut: 45 N·m (4.5 kgf·m, 32.5 lb-ft)



- Turn the steering stem about five or six times to the left and right so that the angular ball bearing will be seated properly.
- Loosen the steering stem nut by $\frac{1}{4}$ - $\frac{1}{2}$ turn.

NOTE:

This adjustment will vary from motorcycle to motorcycle.

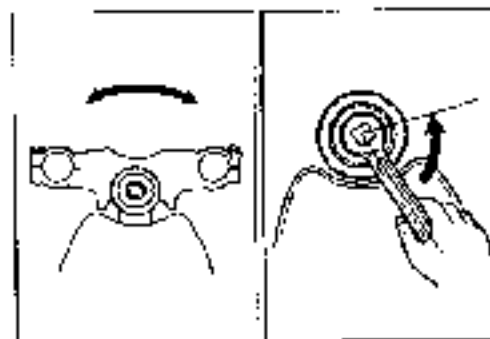

- Install the front fork to the steering stem lower bracket temporarily.
- Install the steering stem upper bracket (1)
- Tighten the steering stem head nut (2)

 Steering stem head nut: 65 N·m (6.5 kgf·m, 47.0 lb-ft)

- Reinstall the front fork (CF 9-30)



HANDLEBARS

- Install the handlebars with the punch mark (A) on the handlebars aligned with the mating surface (B) of the handlebar clamp.

NOTE:

Make sure that the dent (C) on the handlebar clamp faces forward.



- Tighten the handlebar clamp bolt to the specified torque.

U Handlebar clamp bolt: 23 N·m (2.3 kgf·m, 16.5 lb-ft)

NOTE:

When tightening the handlebar clamp bolts, first lighten the bolts ① and then tighten the bolts ②.



- Install the left switch box ③ to the handlebars by engaging the stopper ④ with the hole ⑤ on the handlebars.
- Install the rear brake master cylinder. (CF9-84)

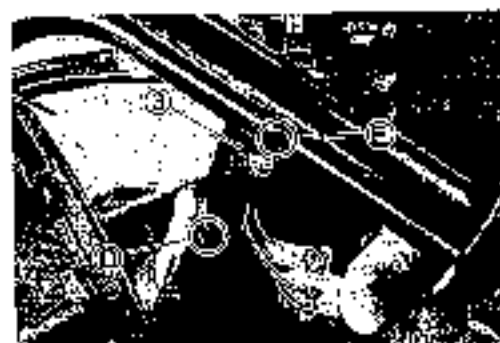

- Install the right switch box ⑥ to the handlebars by engaging the stopper ⑦ with the hole ⑧ on the handlebars.
- Install the front brake master cylinder. (CF9-72)



- Install the handlebar covers and inspect the handlebar cover clearance. (CF9-24)

STEERING TENSION ADJUSTMENT

Check the steering movement in the following procedure.

- By supporting the motorcycle with a jack, lift the front wheel until it is off the floor by 20 – 30 mm (0.8 – 1.2 in).
- Check to make sure that the cables and wire harnesses are properly routed.
- With the front wheel in the straight ahead state, hitch the spring scale (special tool) on one handlebar grip end as shown in the figure and read the graduation when the handlebar starts moving. Do the same on the other grip end.

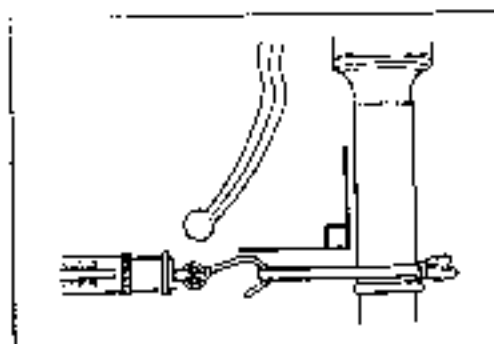

NOTE: Initial force: 200 – 500 grams

Tool: 09940-92720: Spring scale

- If the initial force read on the scale when the handlebar starts turning is either too heavy or too light, adjust it till it satisfies the specification

- 1) First, loosen the front fork upper and lower clamp bolts, steering stem head nut and steering stem nut, and then adjust the steering stem nut by loosening or tightening it
- 2) Tighten the steering stem nut, stem head nut and front fork upper and lower clamp bolts to the specified torque and re-check the initial force with the spring scale according to the previously described procedure.
- 3) If the initial force is found within the specified range, adjustment has been completed.

NOTE:

Hold the front fork legs, move them back and forth and make sure that the steering is not loose.



REAR WHEEL CONSTRUCTION

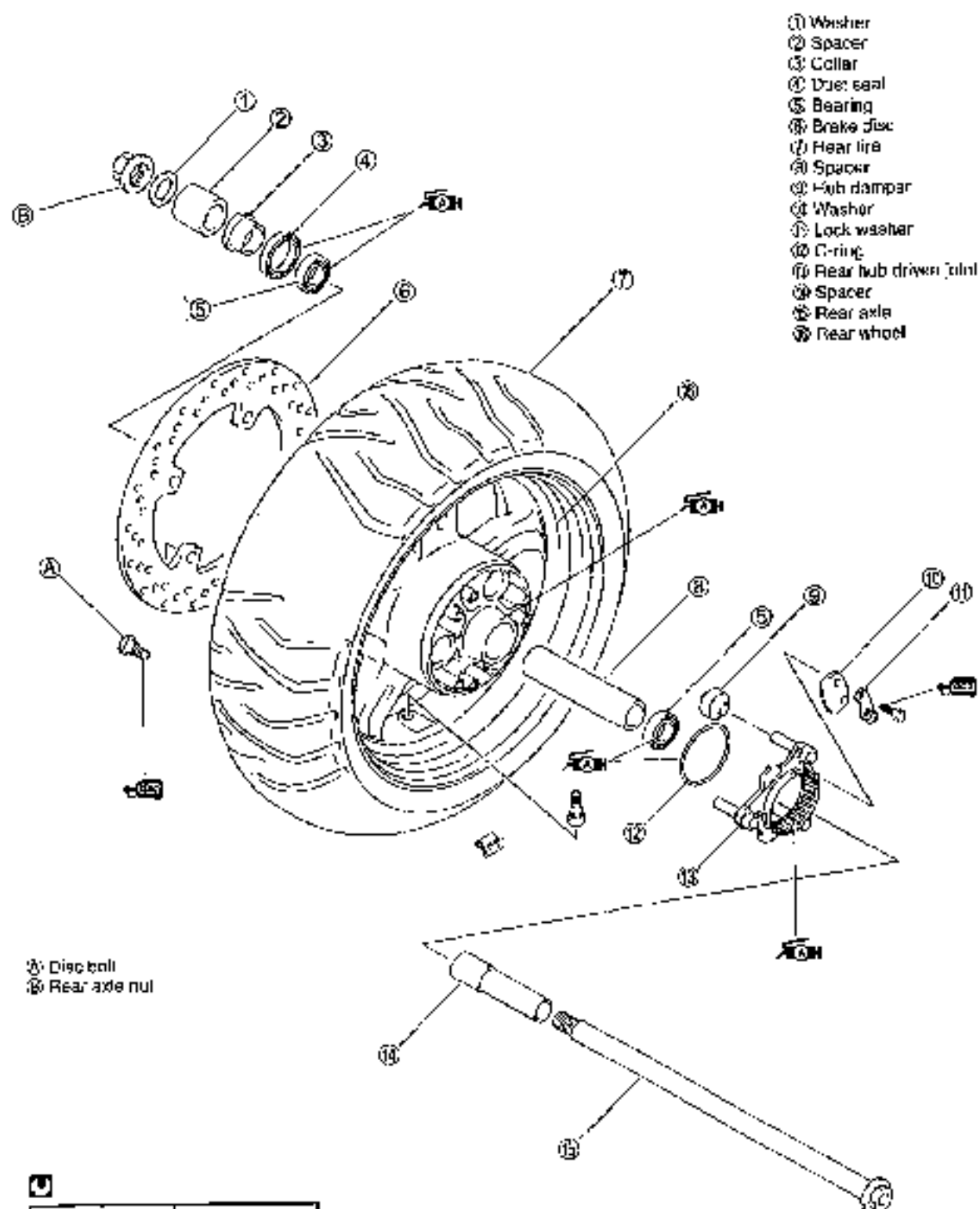

ITEM	N·m	kgf-m	lb-ft
⑮	23	2.3	16.5
⑯	100	10.0	72.5

REMOVAL

- Place the motorcycle on the center stand.
- Remove the final gear case cover ①.

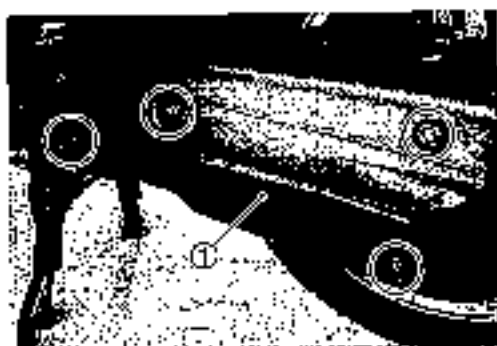

- Disconnect the brake lock cable ②. (C-9-85)



- Remove the cotter pin. (For E-03, 26, 83)
- Loosen the rear axle nut.
- Remove the caliper.
- Remove the axle nut and draw out the rear axle.

CAUTION

Do not operate the brake lever while removing the rear wheel.



- Remove the spacer ③.
- Remove the rear wheel.



- Remove the collars ④.



- Flatten the lock washers (6).
- Remove the bolts and washers (7).

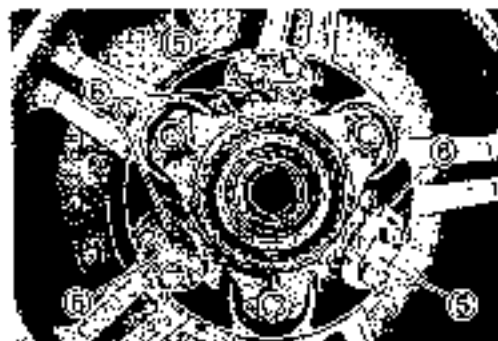

- Remove the rear hub driven point (8).



- Remove the O-ring (9).

CAUTION

Replace the removed O-ring with a new one.



- Remove the brake disc.



INSPECTION AND DISASSEMBLY

TIRE: (C7-9-91)

WHEEL: (C7-9-27 and 9-91)

REAR AXLE

Using a dial gauge, check the rear axle for runout. If the runout exceeds the limit, replace the rear axle.

DATA Axle shaft runout: Service Limit: 0.25 mm (0.010 in)

TOOLS 09900-20607: Dial gauge (1/100 mm)

09900-20701: Magnetic stand

09900-21304: V-block set (100 mm)

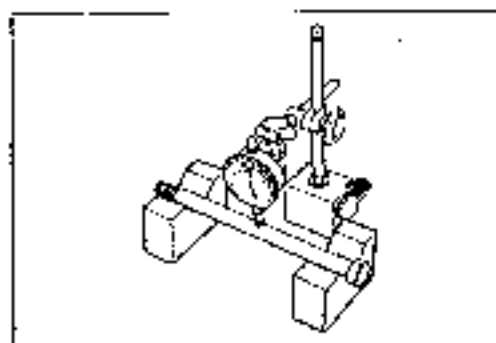

REAR HUB DAMPER

Inspect the dampers for wear and damage. Replace the damper if there is anything unusual.



- Remove the dampers with the appropriate bar.



REAR HUB DRIVEN JOINT

Inspect the rear hub driven joint for wear and damage. If any defects are found, replace it with a new one.



DUST SEAL

Inspect the wheel dust seal lip for wear or damage. If any damages are found, replace the dust seal with a new one.



- Remove the dust seal with the special tool.

 09913-50121: Oil seal remover

CAUTION

Do not reuse the removed dust seal.

**BEARING**

Inspect the play of the wheel bearings by hand while they are in the wheel. Rotate the inner race by hand to inspect for abnormal noise and smooth rotation. Replace the bearing if there is anything unusual.

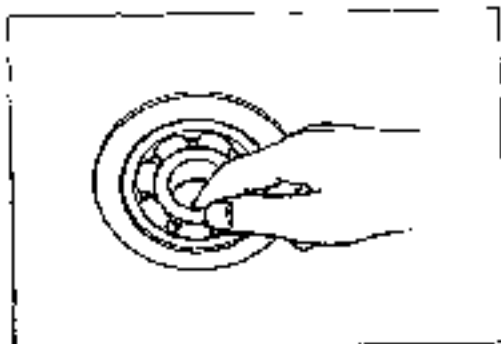

- Remove the wheel bearings by using the special tool.

 09921-20240: Bearing remover set

CAUTION

The removed bearings must be replaced with the new ones.

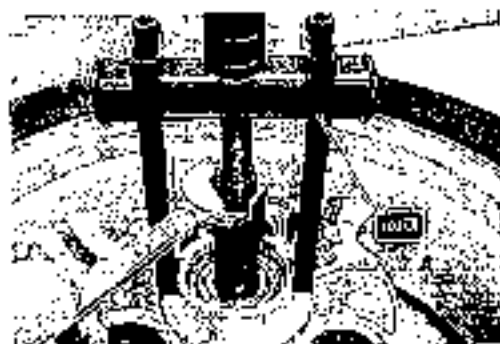

REASSEMBLY AND REMOUNTING

Reassemble and remount the rear wheel in the reverse order of removal and disassembly. Pay attention to the following points:

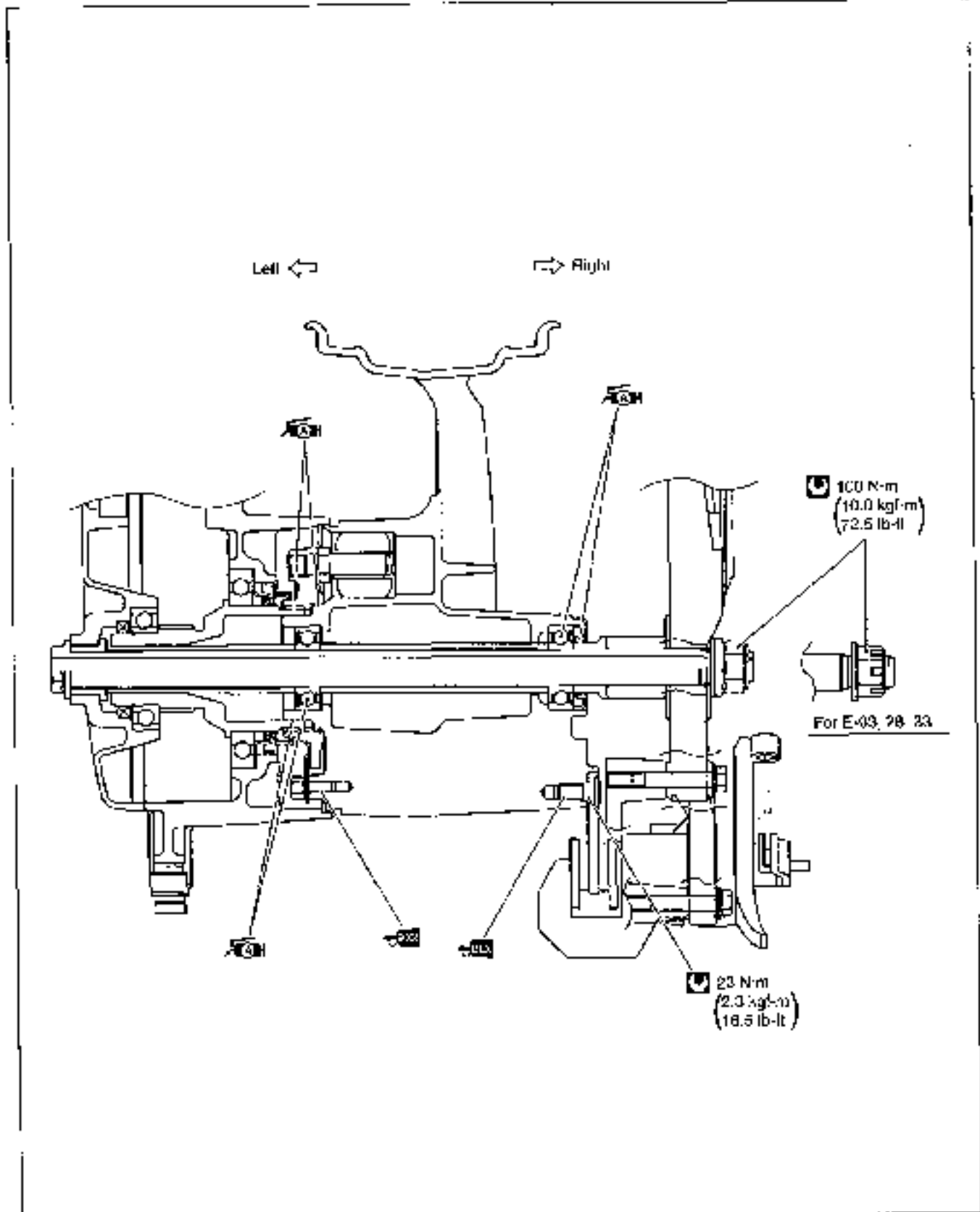

BEARING

- Apply grease to the bearings before installing.

 99000-25010: SUZUKI SUPER GREASE "A"

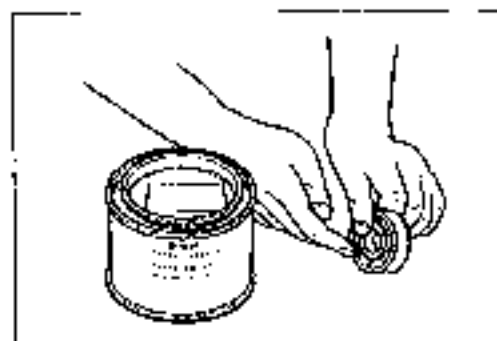

- First install the right wheel bearing, then install the left wheel bearing and spacer using the special tool.

 09941-34513: Bearing/Steering race installer set

CAUTION

The sealed cover of the bearing must face outside.

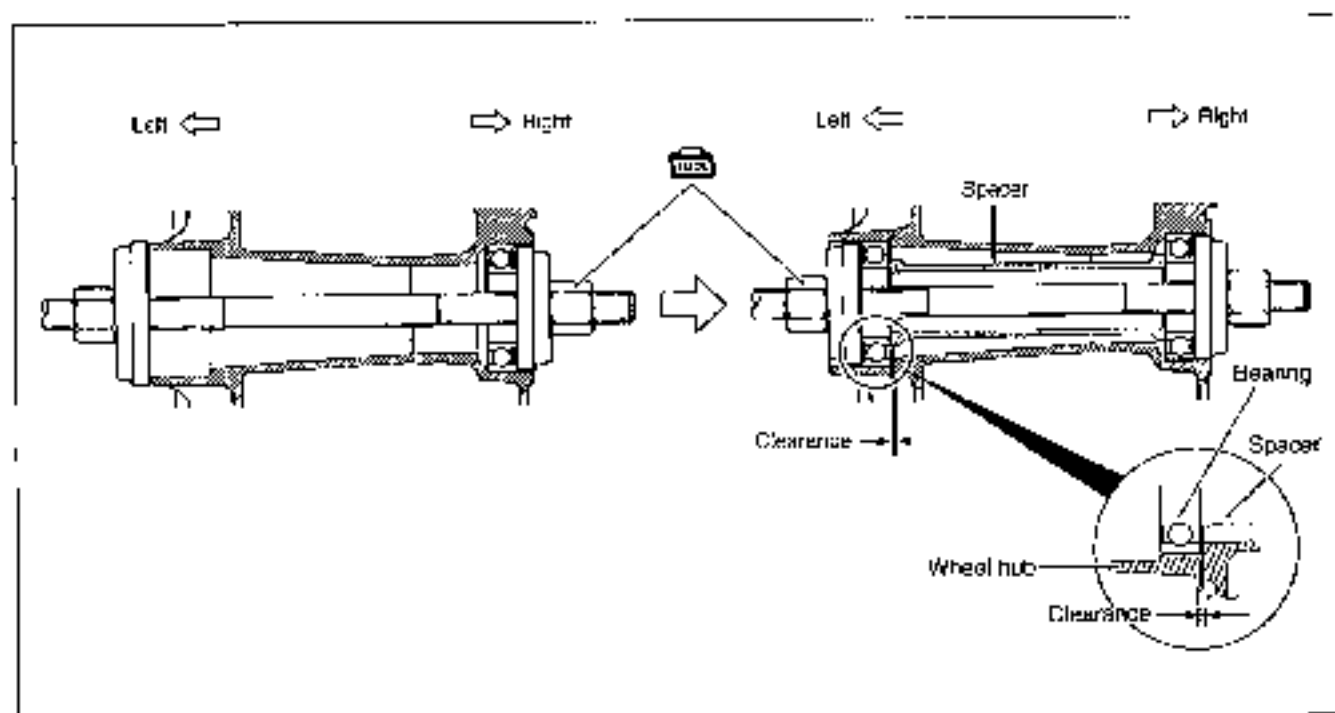

DUST SEAL

- Install the new dust seal using the special tool:

 09913-70210: Bearing Installer set

- Apply SUZUKI SUPER GREASE "A" to the dust seal lips before assembling rear wheel.

 99000-25010: SUZUKI SUPER GREASE "A"

NOTE:

When installing the dust seals, the stamped mark of dust seal must face the special tool.



REAR HUB DAMPER

- Install the rear hub damper into the rear wheel at a depth of 5.5 mm (0.22 in).

NOTE:

Apply soap water to the hub damper before installing the hub damper in order to facilitate press fit.

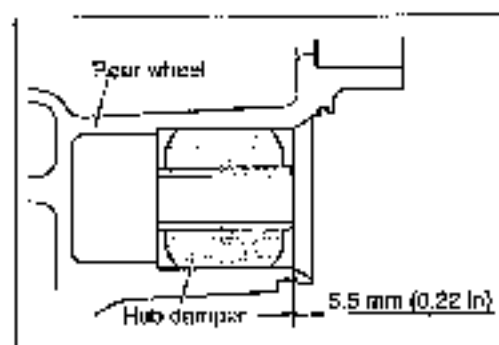

BRAKE DISC

Make sure that the brake disc is clean and free of any greasy matter.

- Apply THREAD LOCK SUPER "1360" to the disc bolts and tighten them to the specified torque.

 99000-32130: THREAD LOCK SUPER "1360"

 Brake disc bolt: 23 N·m (2.3 kgf·m, 16.5 lb-ft)



REAR HUB DRIVEN JOINT

- Apply SUZUKI SUPER GREASE "A" to the O-ring and wheel.

 99000-25010: SUZUKI SUPER GREASE "A"

- Install the O-ring to the rear wheel.

CAUTION

Replace the removed O-ring with a new one.



- Apply SUZUKI SUPER GREASE "A" to the rear hub driven gear joint.

 99000-25010: SUZUKI SUPER GREASE "A"



- Install the rear hub driven gear joint.



- Install the washers (1), lock washers (2).
- Apply **THREAD LOCK SUPER "1303"** to the bolts and tighten them.

 **99000-32030: THREAD LOCK SUPER "1303"**

- Bend the lock washers securely.



- Install the collar.

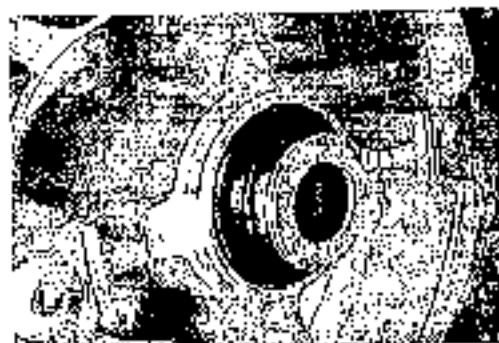

REAR AXLE

- Install the left spacer (1) into the final gear case (2).



- Remove the rear wheel, collar, spacer and rear axle.
- Install the washer and rear axle nut.
- Tighten the rear axle nut (3) to the specified torque.

ⓘ Rear axle nut: 100 N·m (10.0 kgf·m, 72.5 lb-ft)

- Install the new cotter pin. (For E-D3, 28, 33)
- Install the final gear case cover.



- Install the caliper. (☞ 9-81)
- Install the brake lock cable and brake lock arm. (☞ 9-82)
- Adjust the brake lock. (☞ 9-84)

NOTE:

If the caliper pistons come out by operating the rear brake lever while removing the rear caliper, it is impossible to push back the pistons into the caliper because of the brake lock system. Therefore remove the pads and turn the piston clockwise so that the piston will come in. Refer to REAR BRAKE PAD REPLACEMENT page 9-74.

REAR SHOCK ABSORBER CONSTRUCTION

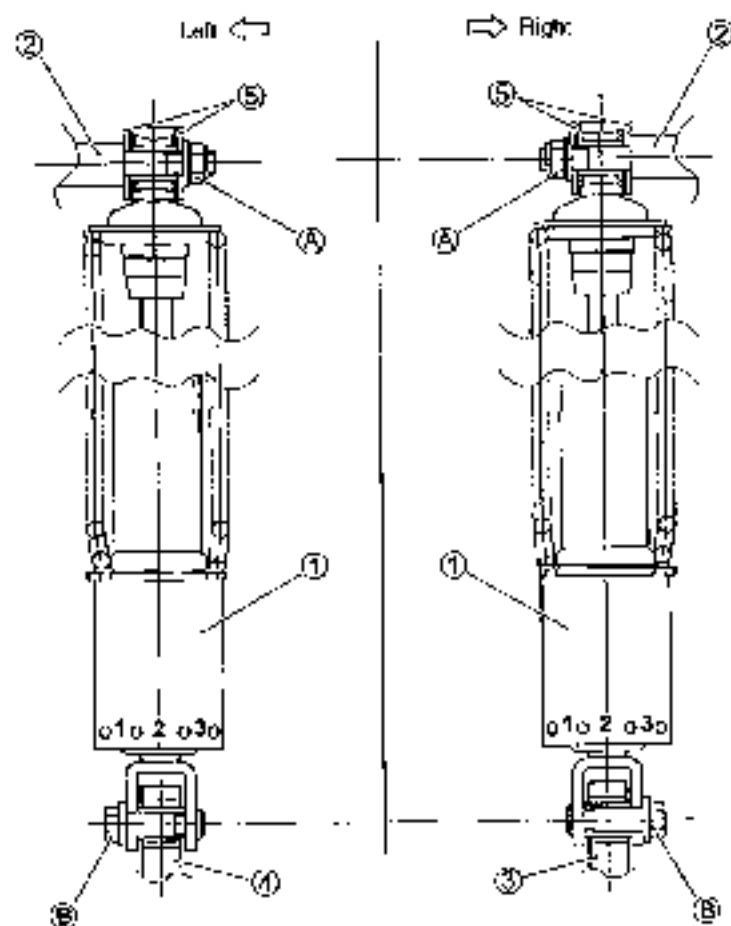

- ① Rear shock absorber
- ② Frame
- ③ Swingarm
- ④ Final gear case
- ⑤ Washer
- ⑥ Rear shock absorber nut
- ⑦ Rear shock absorber bolt



ITEM	N·m	kgf·m	lb·ft
⑥	29	2.9	21.0
⑦	29	2.9	21.0

REMOVAL

- Place the motorcycle on the center stand.
- Remove the rear shock absorber mounting nut ⑥.



- Remove the rear shock absorber mounting bolt ⑦.
- Remove the rear shock absorber.



INSPECTION

Inspect the shock absorber body and bushing for damage and oil leakage.

If any defects are found, replace the shock absorber with a new one.

CAUTION

Do not attempt to disassemble the rear shock absorber unit. It is unserviceable.

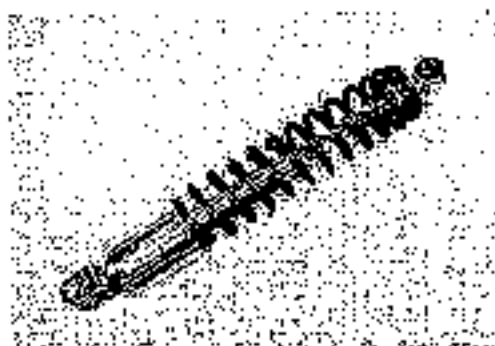

REMOUNTING

• Install the rear shock absorber and tighten the rear shock absorber mounting nut (1) bolt (2).

Ⓜ Rear shock absorber mounting nut:

29 N·m (2.9 kgf-m, 21.0 lb-ft)

Rear shock absorber mounting bolt:

29 N·m (2.9 kgf-m, 21.0 lb-ft)

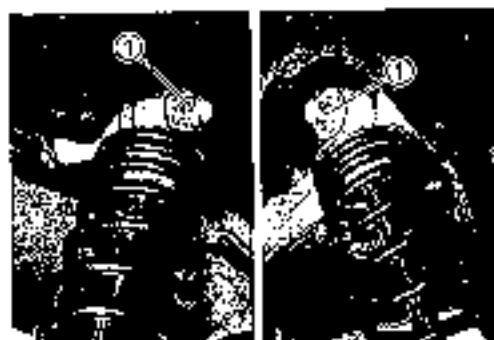

SUSPENSION SETTING

After installing the rear suspension, adjust the spring pre-load as follows.

SPRING PRE-LOAD ADJUSTMENT

The pre-load is adjusted by turning the pre-load adjuster.

Set the indicator (Ⓜ) in the center of absorber lower bracket (Ⓛ).

Position "1" provides the softest spring pre-load.

Position "5" provides the stiffest spring pre-load.

STD position: "2"

CAUTION

Adjust the right and left absorbers to the same settings.



REAR SWINGARM CONSTRUCTION

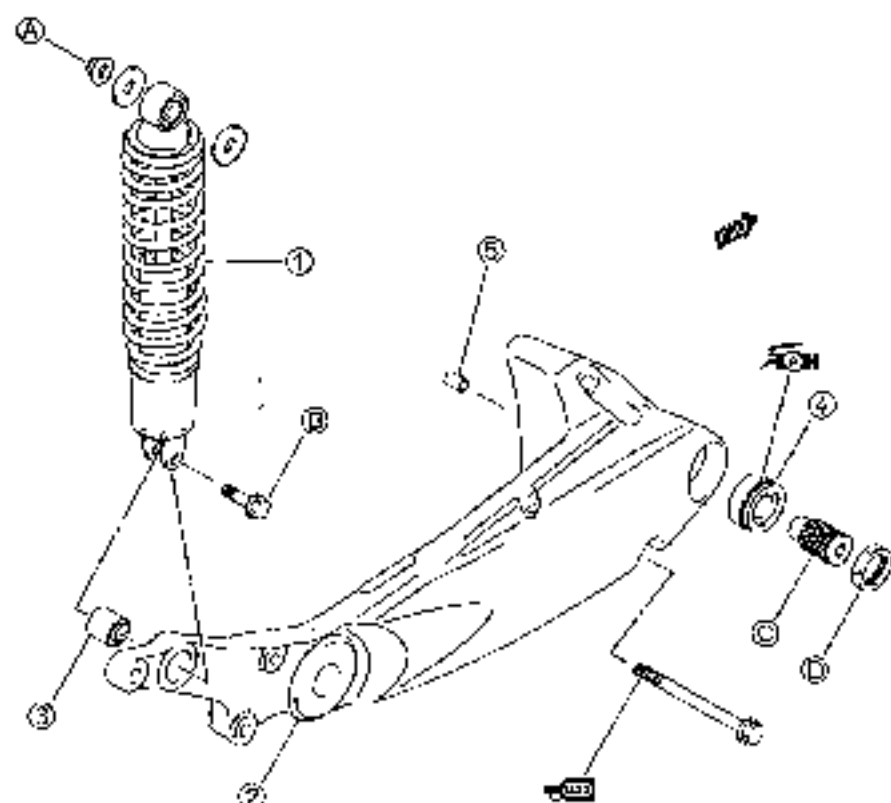

- ① Rear shock absorber
- ② Swingarm
- ③ Bushing
- ④ Bearing
- ⑤ Level pr.

- ⑥ Rear shock absorber mounting nut
- ⑦ Rear shock absorber mounting ball
- ⑧ Pivot ball
- ⑨ Locknut



ITEM	N·m	kgf·m	lb-ft
⑥	29	2.9	21.0
⑦	29	2.9	21.3
⑧	9.5	0.95	7.0
⑨	100	10.0	72.5

REMOVAL

- Place the motorcycle on the center stand.
- Remove the exhaust muffler. (☞ 9-7)
- Remove the rear wheel. (☞ 9-48)
- Remove the rear brake hose guide ①, ②.



- Remove the rear shock absorber bolt ③.



- Remove the swingarm bolts.
- Remove the swingarm (4).

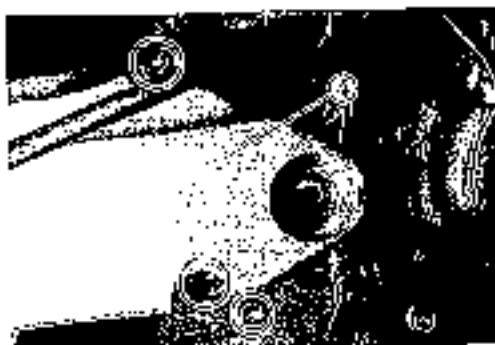

- Remove the swingarm pivot bearing.



- Remove the swingarm pivot locknut (5) and the swingarm pivot bolt (6).



INSPECTION

SWINGARM BEARING

Insert the bearing and check smoothness of rotation.
If there is anything unusual, replace the bearing with a new one.



Inspect the dust seal on the bearing for wear and damage.
If any defects are found, replace the bearing with a new one.



- Remove the swingarm pivot bearing with the special tools.

 09921-20240: Bearing remover set

CAUTION

Do not reuse the removed bearings.

- Install the bearing with the special tool.

 09913-70210: Bearing installer set



BUSHING

Inspect the bushing for damage. If any defects are found, replace it with a new one.

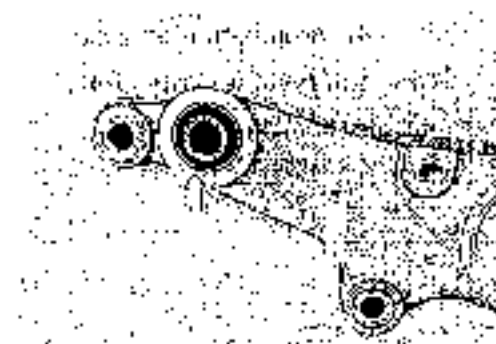

REMountING

Remount the swingarm in the reverse order of disassembly and removal, and pay attention to the following points:

- Apply SUZUKI SUPER GREASE "A" to the bearing, and then install the bearing.

 99000-25010: SUZUKI SUPER GREASE "A"

- Install the dowel pins (1).

- Install the swingarm.
- Apply THREAD LOCK SUPER "1322" to the swingarm bolts.
- Tighten the swingarm bolt.

 99000-32110: THREAD LOCK SUPER "1322"

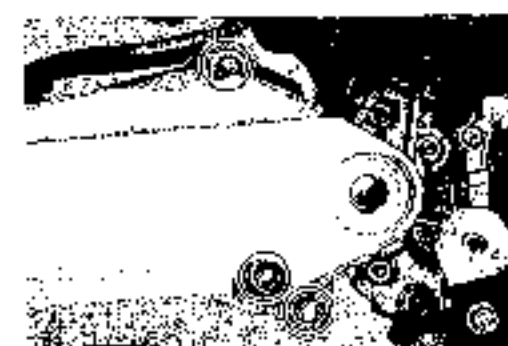
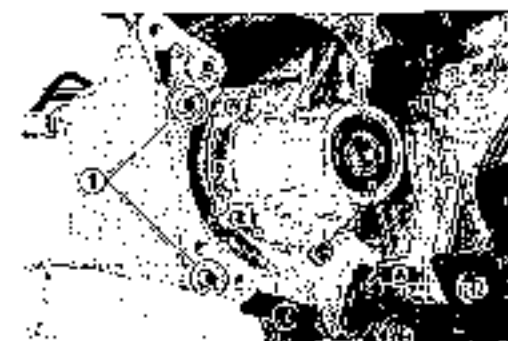

- Tighten the swingarm pivot bolt to the specified torque.

 **Swingarm pivot bolt: 9.5 N·m (0.95 kgf-m, 7.0 lb-ft)**



- Tighten the swingarm pivot locknut (2) to the specified torque.

 **Swingarm pivot locknut: 100 N·m (10.0 kgf-m, 72.5 lb-ft)**

- Install the rear wheel. (279-56)
- Install the exhaust muffler. (273-11)

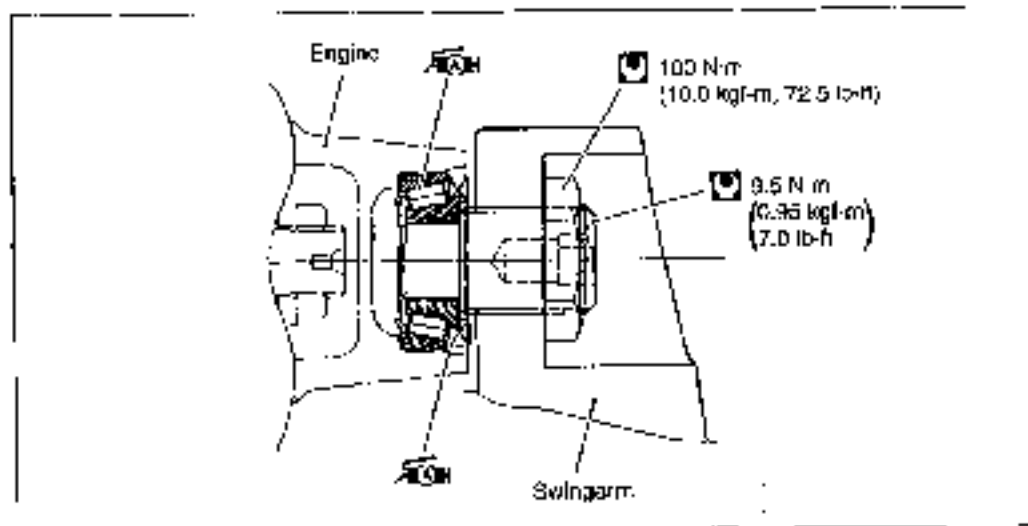

FRONT BRAKE CONSTRUCTION

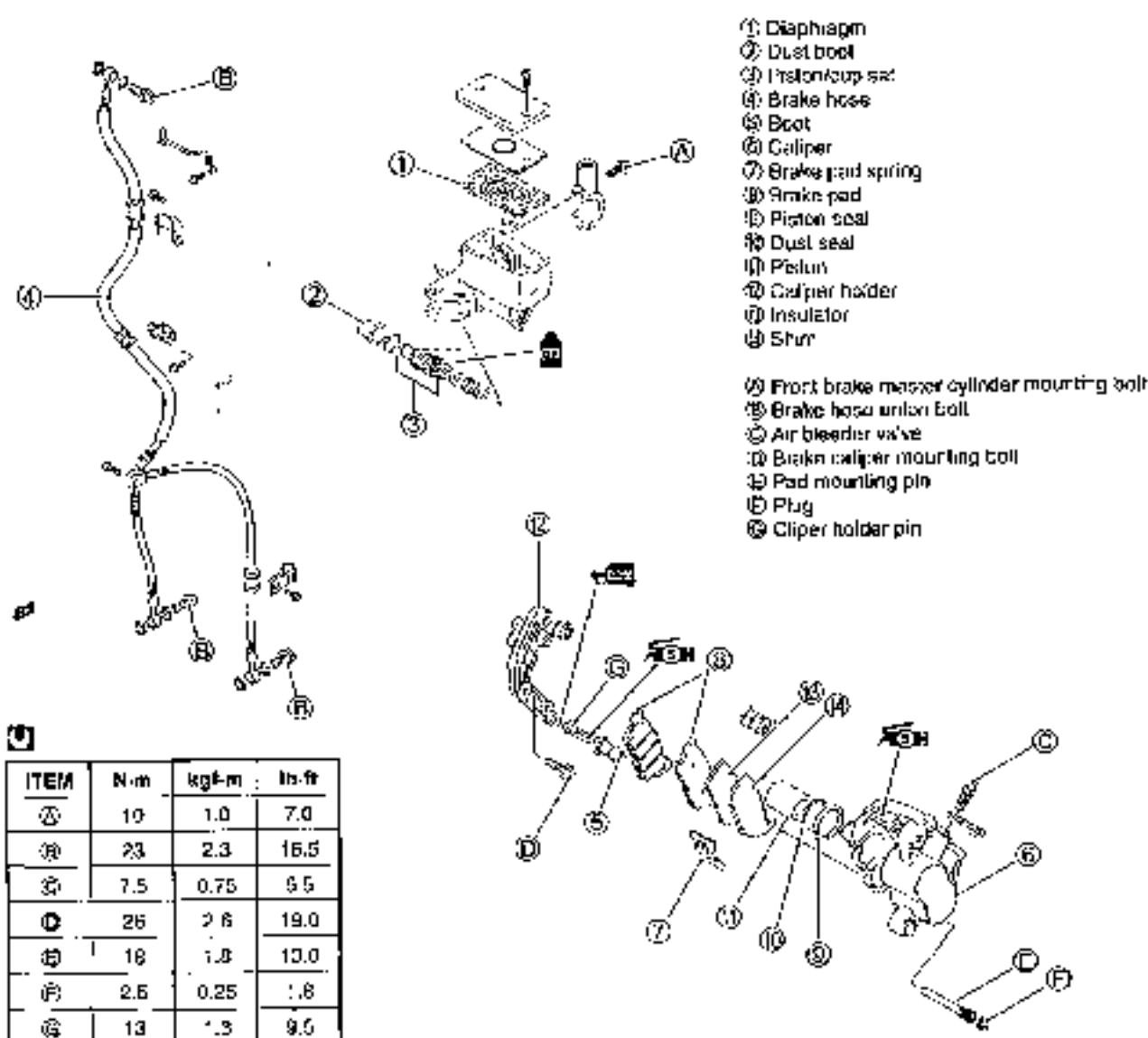

ITEM	N·m	kgf·m	in·ft
15	10	1.0	7.0
16	23	2.3	16.5
18	7.5	0.75	5.5
19	25	2.5	19.0
20	18	1.8	13.0
21	2.5	0.25	1.8
22	13	1.3	9.5

⚠ WARNING

- * This brake system is filled with an ethylene glycol-based DOT 4 brake fluid. Do not use mix different types of fluid such as silicone-based or petroleum-based.
- * Do not use any brake fluid taken from old, used or unsealed containers. Never reuse brake fluid left over from the last servicing or stored for long periods.
- * When storing the brake fluid, seal the container completely and keep away from children.
- * When replenishing brake fluid, take care not to get dust into fluid.
- * When washing brake components, use fresh brake fluid. Never use cleaning solvent.
- * A contaminated brake disc or brake pad reduces braking performance. Discard contaminated pads and clean the disc with high quality brake cleaner or neutral detergent.

⚠ CAUTION

Handle brake fluid with care: the fluid reacts chemically with paint, plastics, rubber materials etc. and will damage them severely.

BRAKE PAD REPLACEMENT

- Remove the plug (1).



- Remove the pad mounting pin (2).



- Remove the pads (3).
- Inspect the pad mounting pin for wear. If excessive wear is found, replace the mounting pin with a new one.



- Assemble the new brake pad (4), insulator (5) and shim (6).

CAUTION

Replace the brake pads as a set, otherwise braking performance will be adversely affected.

NOTE:

The pad fitted shim and insulator must be installed at piston side.

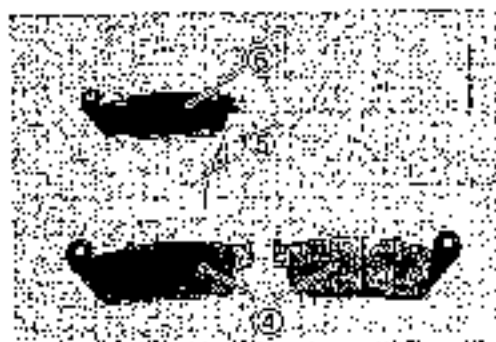

- Install the brake pads.



- Tighten the pad mounting pin (7) to the specified torque.

7 Front brake pad mounting pin:

18 N·m (1.8 kgf-m, 13.0 lb-ft)

- Install the brake hose clamp bolt.



- Install the plug (8) and tighten it to the specified torque.

8 Pad pin plug: **2.5 N·m (0.25 kgf-m, 1.8 lb-ft)**

NOTE:

After replacing the brake pads, pump the brake lever several times in order to operate the brake correctly and then check the brake fluid level.



BRAKE FLUID REPLACEMENT

- Place the motorcycle on a level surface and keep the handlebars straight.
- Remove the brake fluid reservoir cap and diaphragm.
- Suck up the old brake fluid as much as possible.
- Fill the reservoir with the new brake fluid.

11 Specification and Classification: DOT 4



- Connect a clear hose to the caliper air bleeder valve and insert the other end of hose into a receptacle.
- Loosen the air bleeder valve and pump the brake lever until old brake fluid flows out of the bleeder system.
- Close the caliper air bleeder valve and disconnect a clear hose. Fill the reservoir with the new fluid to the upper mark of the reservoir.

 Brake air bleeder valve: 7.5 N·m (0.75 kgf·m, 5.5 lb-ft)



CAUTION

- Never reuse the brake fluid left over from previous servicing and which has been stored for long periods of time.
- Bleed air from the brake system.
( 2-24)

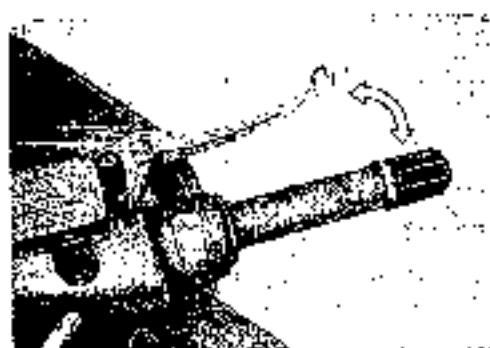

CALIPER REMOVAL AND DISASSEMBLY

- Drain the brake fluid. ( 9-65)
- Disconnect the brake hoses by removing the brake hose union bolts.

CAUTION

Place a rag underneath the union bolt on the brake caliper to catch any spilt brake fluid.

- Remove the brake calipers by removing the caliper mounting bolts.
- Remove the brake pads. ( 9-64)
- Remove the caliper holder (1).
- Remove the pad spring (2).

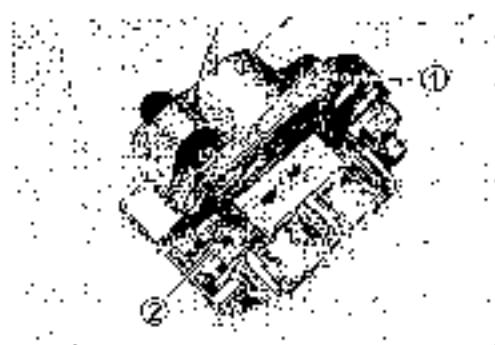

- Place a rag over the pistons to prevent them from popping out and then force out the pistons using compressed air

CAUTION

Do not use high pressure air to prevent piston damage.

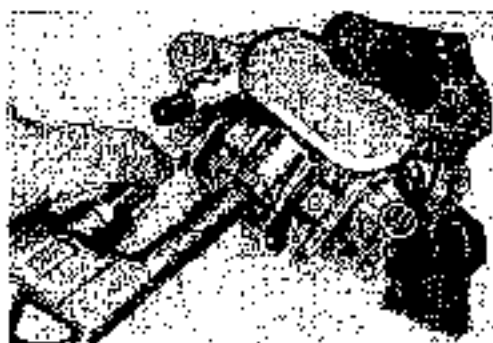

- Remove the dust seals and piston seals

CAUTION

Do not reuse the removed dust seals and piston seals to prevent fluid leakage.

**CALIPER INSPECTION****BRAKE CALIPER**

Inspect the brake caliper cylinder wall for nicks, scratches and other damage. If any damage is found, replace the caliper with a new one.

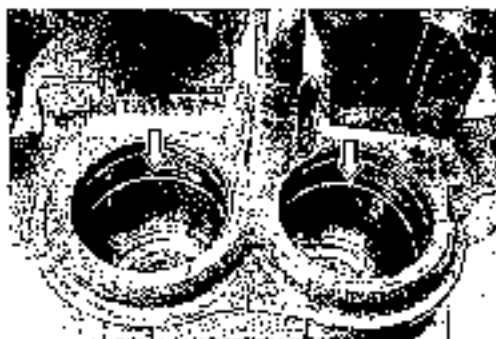
**BRAKE CALIPER PISTON**

Inspect the brake caliper piston surface for any scratches and other damage. If any damage is found, replace the caliper piston with a new one.

**CALIPER HOLDER**

- Inspect the caliper holder for damage. If any damage is found, replace it with a new one.



RUBBER PARTS

Inspect the rubber parts for damage. If any damage is found, replace them with the new ones.

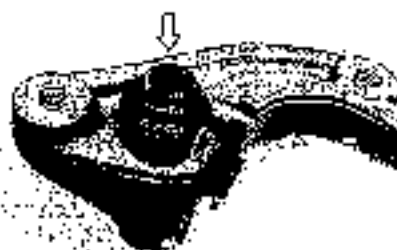
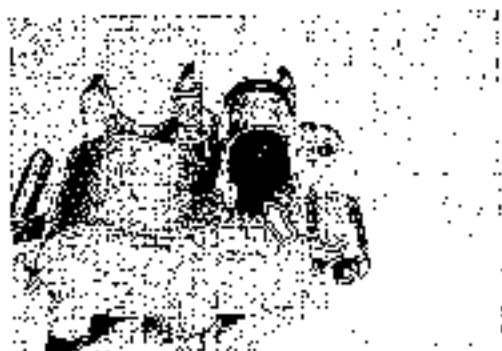
**CALIPER REASSEMBLY AND REMOUNTING**

Reassemble the caliper in the reverse order of removal and disassembly. Pay attention to the following points:

- Wash the caliper bores and pistons with specified brake fluid. Particularly wash the dust seal groove and piston seal groove.

 **Specification and Classification: DOT 4**

[CAUTION]

- Wash the caliper components with fresh brake fluid before reassembly. Never use cleaning solvent or gasoline to wash them.
- Do not wipe the brake fluid off after washing the components with a rag.
- When washing the components, use the specified brake fluid. Never use different types of fluid or cleaning solvent such as gasoline, kerosene or the others.
- Replace the piston seals and dust seals with the new ones when reassembly.
- Apply the brake fluid to both seals when installing them.

PISTON SEAL

- Install the piston seal and dust seal as shown in the illustration.
- Install the piston to the caliper.

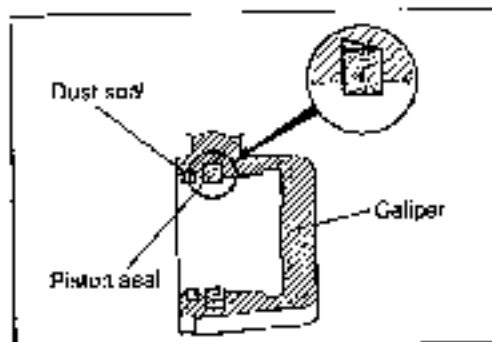
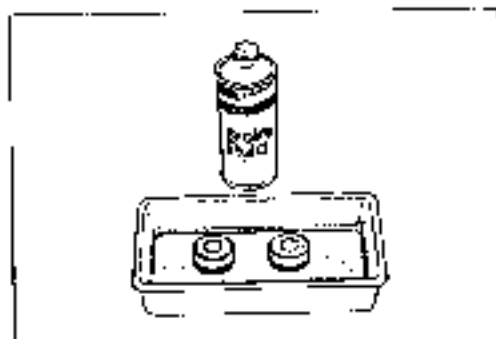

CALIPER HOLDER

- Apply **THREAD LOCK SUPER "1303"** to the pin (2).
- **99000-32030: THREAD LOCK SUPER "1303"**
- Tighten the pin (2) to the caliper holder (1) to the specified torque.

1 Caliper holder pin: 13 N·m (1.3 kgf-m, 9.5 lb-ft)

- Apply **SUZUKI SILICONE GREASE** to the brake caliper holder pin (2).

99000-25100: SUZUKI SILICONE GREASE

- Be sure to check that the boot is fitted on the slide pin.

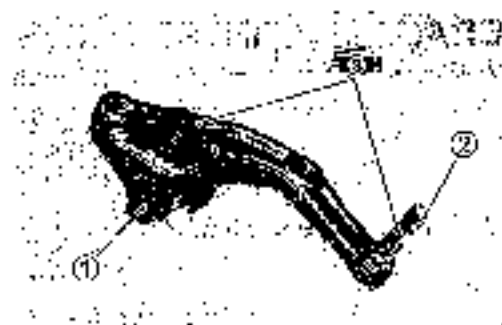

- Install the pad spring (3).
- Install the brake pads. (C-7-84)

NOTE:

Before remounting the caliper, push the piston all the way into the caliper.



- Remount the brake caliper to the front fork.
- Tighten each bolt to the specified torque.

4 Front brake caliper mounting bolt (4):

26 N·m (2.6 kgf-m, 19.0 lb-ft)

Front brake hose union bolt (5):

23 N·m (2.3 kgf-m, 16.5 lb-ft)

CAUTION

- The seal washers should be replaced with the new ones to prevent fluid leakage.
- Bleed air from the system after reassembling the caliper. (C-7-24)
- Brake fluid, if it leaks, will interfere with safe running and discolor painted surfaces. Check the brake hose and hose joints for cracks and fluid leakage.



BRAKE DISC INSPECTION

Visually check the brake disc for damage or cracks.

Measure the thickness with a micrometer.

Replace the disc if the thickness is less than the service limit or if damage is found.

DATA Front disc thickness

Service Limit: 4.0 mm (0.16 in)

TOOL 09900-20205: Micrometer (0 – 25 mm)

Measure the runout with a dial gauge

Replace the disc if the runout exceeds the service limit.

DATA Front disc runout

Service Limit: 0.30 mm (0.012 in)

TOOL 09900-20807: Dial gauge (1/100 mm)

09900-20701: Magnetic stand

* Brake disc removal (☞ 9-27)

* Brake disc installation (☞ 9-30)

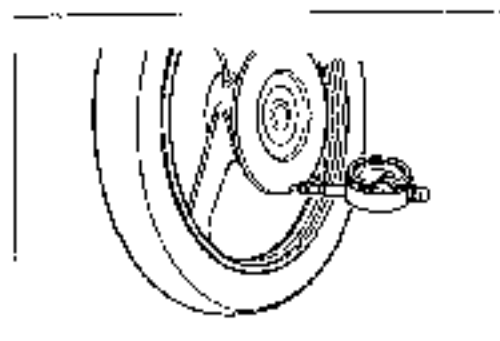
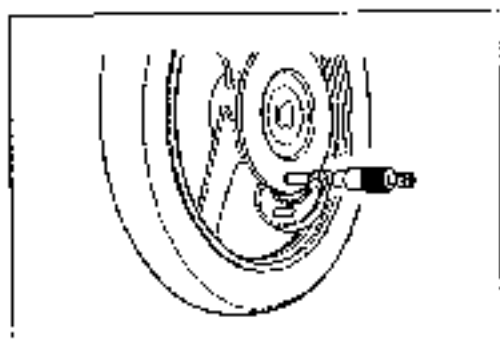

MASTER CYLINDER REMOVAL AND DISASSEMBLY

- Remove the handlebar cover. (☞ 9-8)
- Drain the brake fluid. (☞ 9-85)
- Disconnect the front brake light switch coupler (1).
- Place a rag underneath the union bolt on the master cylinder to catch any spill brake fluid. Remove the brake hose union bolt and disconnect the brake hose.
- Remove the master cylinder.



CAUTION

Immediately and completely wipe off any brake fluid contacting any part of the motorcycle. The fluid reacts chemically with paint, plastics and rubber materials, etc. and will damage them severely.

- Remove the brake lever (2) and brake switch (3).



- Pull out the dust boot (4) and remove the snap ring (5).

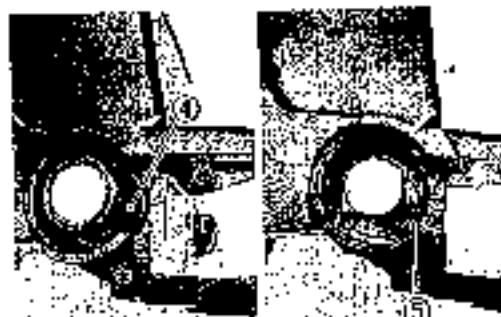

- Remove the piston and return spring.

- (6) Piston
- (7) Secondary cup
- (8) Primary cup
- (9) Return spring

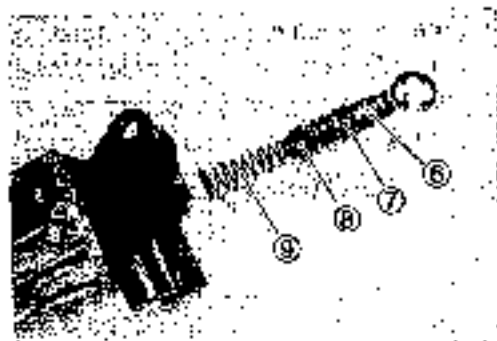

MASTER CYLINDER INSPECTION

Inspect the master cylinder bore for any scratches or other damage.

Inspect the piston surface for any scratches or other damage.

Inspect the primary cup, secondary cup and dust boot for wear or damage.

If any defects are found, replace them with new ones.





MASTER CYLINDER REASSEMBLY AND REMOUNTING

Reassemble the master cylinder in the reverse order of removal and disassembly. Pay attention to the following points:

CAUTION

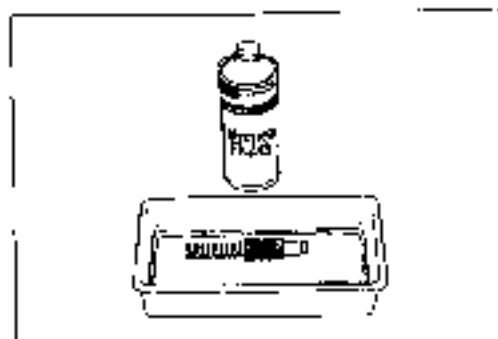
- * Wash the master cylinder components with fresh brake fluid before reassembly. Never use cleaning solvent or gasoline to wash them.
- * Do not wipe the components with a rag.
- * Apply brake fluid to the cylinder bore and all the component to be inserted into the bore.



 Specification and Classification: DOT 4

- Apply brake fluid to the piston and cups.
- Install the following parts to the master cylinder.

- ① Dust boot
- ② Snap ring
- ③ Secondary cup
- ④ Piston
- ⑤ Primary cup
- ⑥ Return spring

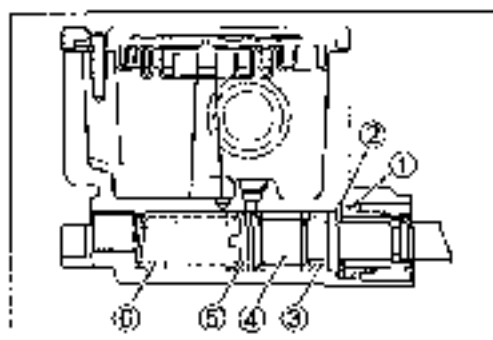

- When remounting the brake master cylinder onto the handlebars, align the master cylinder holder's mating surface ④ with punch mark ⑤ on the handlebars and tighten the upper bolt ⑦ first.

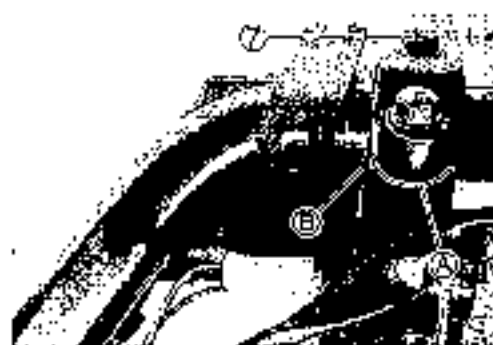

- **Front brake master cylinder mounting bolt:**
10 N-m (1.0 kgf-m, 7.0 lb-ft)

- After touching the brake hose union to the stopper, tighten the brake hose union bolt to the specified torque.



- **Brake hose union bolt:** 23 N-m (2.3 kgf-m, 16.6 lb-ft)

CAUTION

- The seal washers should be replaced with the new ones to prevent fluid leakage.
- Bleed air from the system after reassembling the master cylinder. (☞ 2-24)

REAR BRAKE CONSTRUCTION

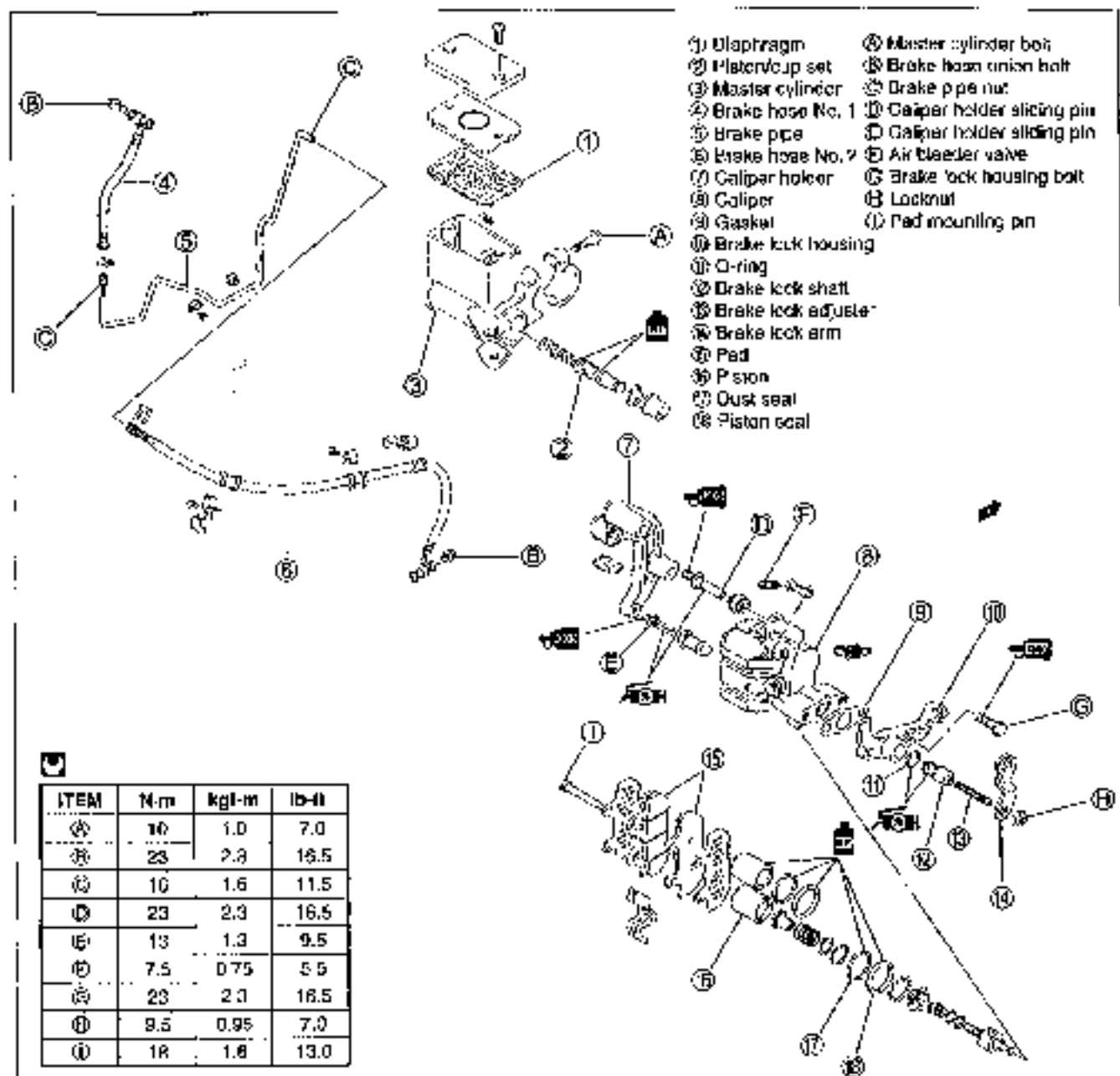

ITEM	N·m	kgf·m	lb-ft
19	10	1.0	7.0
20	23	2.3	16.5
21	10	1.0	11.5
22	23	2.3	16.5
25	13	1.3	9.5
26	7.5	0.75	5.5
27	23	2.3	16.5
28	9.5	0.95	7.0
29	1R	1.6	13.0

▲ WARNING

- * This brake system is filled with an ethylene glycol-based DOT 4 brake fluid. Do not use or mix different types of fluid such as silicone-based or petroleum-based.
- * Do not use any brake fluid taken from old, used or unsealed containers. Never reuse brake fluid left over from the last servicing or stored for long periods.
- * When storing the brake fluid, seal the container completely and keep away from children.
- * When replenishing brake fluid, take care not to get dust into fluid.
- * When washing brake components, use fresh brake fluid. Never use cleaning solvent.
- * A contaminated brake disc or brake pad reduces braking performance. Discard contaminated pads and clean the disc with high quality brake cleaner or neutral detergent.

CAUTION

Handle brake fluid with care; the fluid reacts chemically with paint, plastics, rubber materials etc. and will damage them severely.

BRAKE PAD REPLACEMENT

- Remove the brake lock arm (1) and spring (2).
- Disconnect the brake lock cable (3). (I²*9-85)



- Remove the caliper.

CAUTION

Do not operate the brake lever while dismantling the pads.



- Remove the pad mounting pins (4), and then remove the brake pads.
- Clean up the caliper especially around the pistons.



- Inspect the pad mounting pins for wear. If excessive wear is found, replace the mounting pins with new ones.



- Assemble the new pads (5), insulators (6) and shims (7).

CAUTION

Replace the brake pads as a set, otherwise braking performance will be adversely affected.



- Turn the piston (A) clockwise until it stops.
- Align the groove with line (B) by turning the piston out.
- Install the pad with the projection (C) fitted in the groove on the piston.



- Install the pad to the caliper with the pad seated at the hatched area (D) of pad spring.



- Tighten the pad mounting pins to the specified torque.

U Pad mounting pin: 18 N·m (1.8 kgf·m, 13.0 lb-ft)



- Install the caliper.
- Tighten the caliper mounting bolt to the specified torque.

U Caliper mounting bolt: 26 N·m (2.6 kgf·m, 19.0 lb-ft)

NOTE:

After replacing the brake pads, pump the brake lever several times to check for proper brake operation and then check the brake fluid level.



- Install the brake lock cable. (CJ7-9-86)
- Install the brake lock arm with the punch mark (G) aligned with punch mark (H) on the brake lock shaft.

NOTE:

Make sure that the spring end faces to right side of the vehicle.

- Adjust the brake lock (CJ7-9-84)



BRAKE FLUID REPLACEMENT

- Place the motorcycle on a level surface and keep the handlebars straight.
- Remove the brake fluid reservoir cap and diaphragm.
- Suck up the old brake fluid as much as possible.
- Fill the reservoir with the new brake fluid.

 **Specification and Classification: DOT 4**

- Connect a clear hose to the caliper air bleeder valve and insert the other end of hose into a receptacle.
- Loosen the air bleeder valve and pump the brake lever until old brake fluid flows out of the bleeder system.
- Close the caliper air bleeder valve and disconnect a clear hose. Fill the reservoir with the new fluid to the upper mark of the reservoir.

 **Brake air bleeder valve: 7.5 N·m (0.75 kgf-m, 5.5 lb-ft)**

CAUTION

- Never reuse the brake fluid left over from previous servicing and which has been stored for long periods of time.
- Bleed air from the brake system.
([C-2-25](#))

CALIPER REMOVAL AND DISASSEMBLY

- Drain the brake fluid. ([C-2-25](#) above)
- Disconnect the brake lock cable ([C-9-85](#))
- Disconnect the brake hose.
- Remove the caliper.
- Remove the brake pads. ([C-9-74](#))

CAUTION

Place a rag underneath the union bolt on the brake caliper to catch any spilt brake fluid.

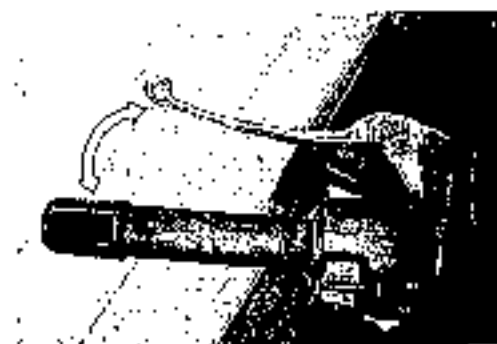

- Remove the pad spring ① and caliper holder ②.



- Remove the parking brake housing ③.

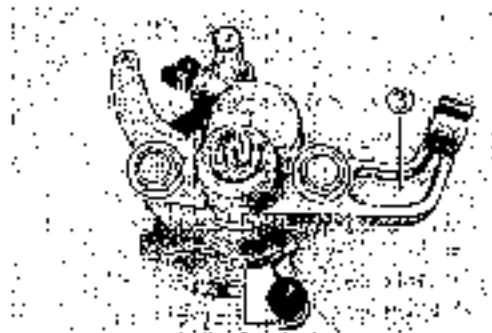

- Disassemble the parking brake.

CAUTION

Replace the removed O-ring with a new one.

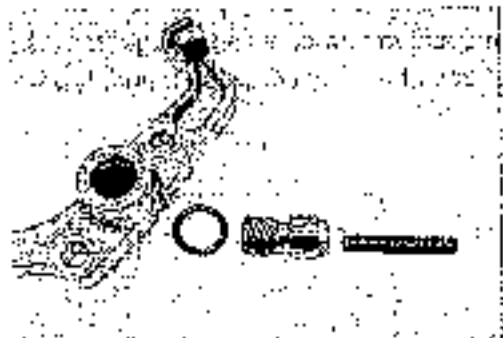

- Turn the piston counterclockwise fully.

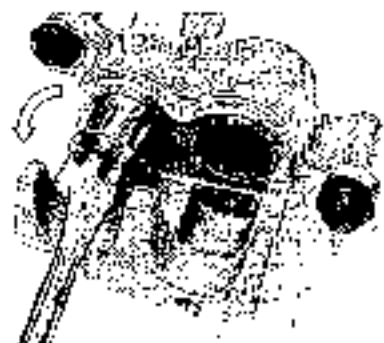

- Place a rag over the piston to prevent it from popping out and then force out the piston using compressed air.

CAUTION

Do not use high pressure air to prevent piston damage.

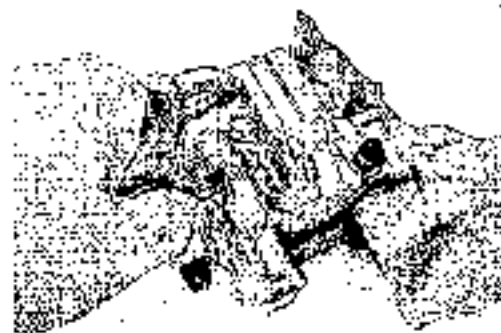

- Remove the dust seals (4) and piston seals (5).

CAUTION

Do not raise the dust seal and piston seal to prevent fluid leakage.



CALIPER INSPECTION

BRAKE CALIPER

Inspect the brake caliper cylinder walls for nicks, scratches and other damage. If any damage is found, replace the caliper with a new one.

CAUTION

Do not attempt to disassemble the brake lock bolt that is built in the caliper. It is unserviceable.



Inspect the brake fluid leakage from O-ring (1) and cup (2). If any abnormal condition found, replace the rear brake caliper.

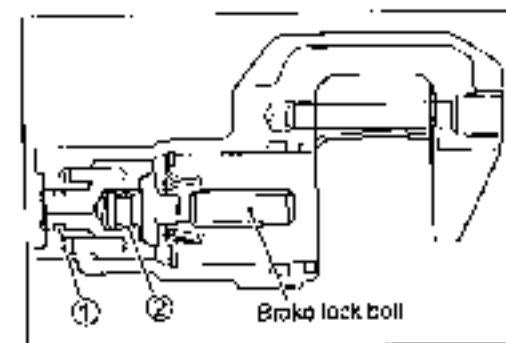

BRAKE CALIPER PISTON

Inspect the brake caliper piston's surface for any scratches and other damage. Inspect the grooved piston for spring tension by pushing the retainer (1). If any damage is found, replace the caliper piston with a new one.

CAUTION

Do not attempt to disassemble the piston. It is unserviceable.

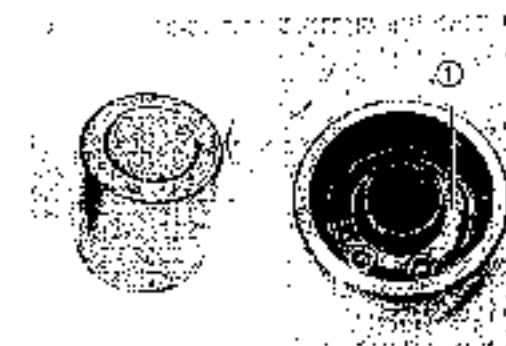

CALIPER HOLDER

Inspect the brake holder sliding pins for wear and other damage. If any damage is found, replace the sliding pin with a new one.

**BOOT**

Inspect the boots for damage and wear. If any damage is found, replace boots with new ones.

**CALIPER REASSEMBLY AND REMOUNTING**

Reassemble and remount the caliper in the reverse order of removal and disassembly. Pay attention to the following points:

CAUTION

- Wash the caliper components with fresh brake fluid before reassembly. Never use cleaning solvent or gasoline to wash them.
- Apply brake fluid to the caliper bore and piston to be inserted into the bore.

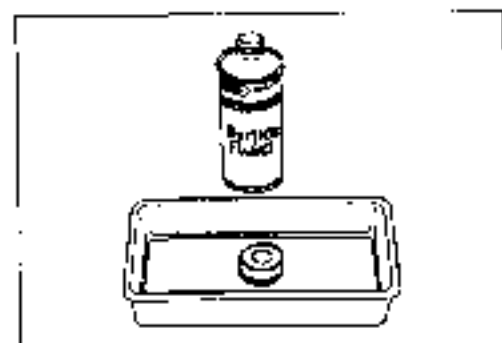

 Specification and Classification: DOT 4

PISTON SEAL

- Install the piston seals as shown in the right illustration.
- Install the pistons to the caliper.

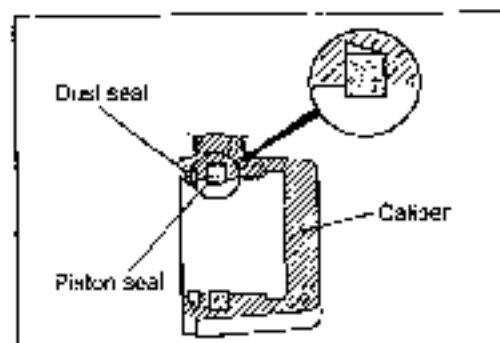

- Turn the piston clockwise fully

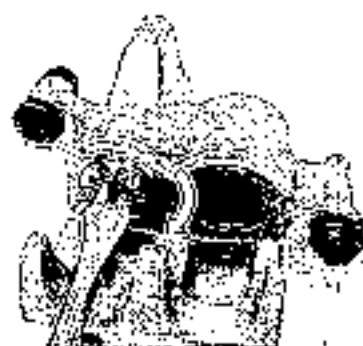

- Install the pad spring ①.



CALIPER HOLDER

- Apply THREAD LOCK SUPER "1303" to the sliding pins.

 99000-32030: THREAD LOCK SUPER "1303"

- Tighten the sliding pins ①, ② to the specified torque.

 Caliper sliding pin ①: 23 N·m (2.3 kgf·m, 16.5 lb-ft)

Caliper sliding pin ②: 13 N·m (1.3 kgf·m, 9.5 lb-ft)

- Apply SUZUKI SILICONE GREASE to the sliding pin.

 99000-25100: SUZUKI SILICONE GREASE

- Install the caliper holder to the caliper.
- Set the boot onto the sliding pin securely.
- Install the brake pad. (C 9-75)

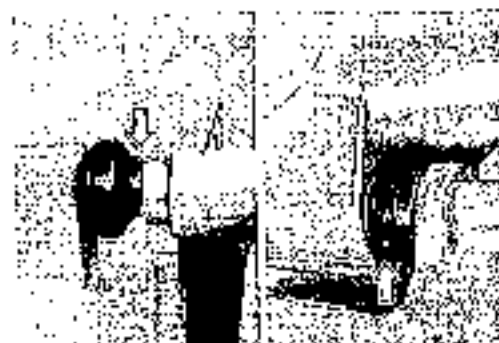
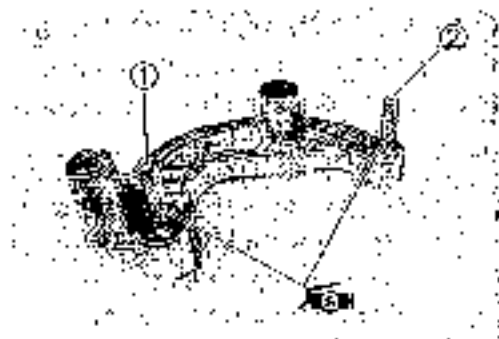

CALIPER

- Install the caliper.
- Tighten the caliper mounting bolts (1) to the specified torque.

1 Rear caliper mounting bolt: 26 N·m (2.6 kgf-m, 19.0 lb-ft)



- Connect the brake hose (2) to the caliper with the brake hose union pipe seated in the cutaway on the caliper.
- Tighten the brake hose union bolt to the specified torque.

2 Brake hose union bolt: 23 N·m (2.3 kgf-m, 16.5 lb-ft)

CAUTION

- The seal washers should be replaced with the new ones to prevent fluid leakage.
- Bleed air from the system after reassembling the caliper. (2-25)
- Brake fluid, if it leaks, will interfere with safe running and discolor painted surfaces. Check the brake hose and hose joints for cracks and fluid leakage.

**BRAKE LOCK**

- Apply SUZUKI SILICONE GREASE to the brake lock ball end (3).

3 99000-25100: SUZUKI SILICONE GREASE



- Install the new gasket and the brake lock housing to the caliper.
- Apply THREAD LOCK SUPER "1360" to the brake lock bolts.

4 99000-32130: THREAD LOCK SUPER "1360"

- Tighten the brake lock housing bolts to the specified torque

5 Brake lock housing bolt: 23 N·m (2.3 kgf-m, 16.5 lb-ft)

- Apply SUZUKI SILICONE GREASE to the O-ring.

6 99000-25100: SUZUKI SILICONE GREASE

- Install the O-ring into the brake lock housing.

CAUTION

Replace the gasket and O-ring with new ones.

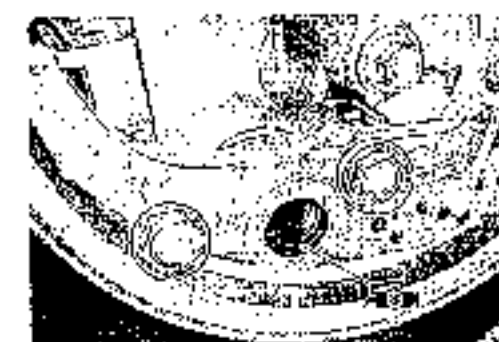

- Apply SUZUKI SILICONE GREASE to the brake lock shaft.

 99000-25100: SUZUKI SILICONE GREASE



- Install the brake lock shaft so that the punch mark (B) can be positioned in (C) when the brake lock shaft is turned clockwise until it stops.



- Install the brake lock cable and E-ring.



- Install the brake lock adjust bolt (1) to the brake lock shaft.
- Turn the brake lock shaft about 90 degree counterclockwise so that the punch mark (D) will face upward.

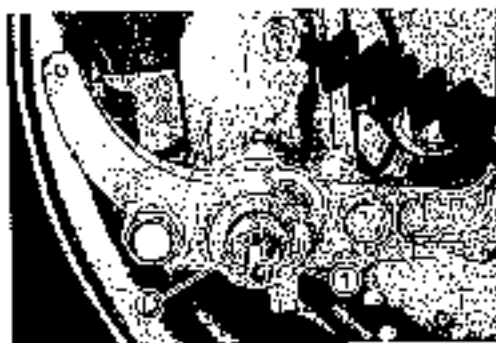

- Install the brake lock arm (2) with the punch mark (E) aligned with the punch mark (F) on the brake lock arm (2).
- Hook the spring and connect the brake arm (2) with the brake lock cable.

NOTE:

Make sure that the spring end faces to right side of the vehicle.

- Adjust the brake lock. (C79-85)



BRAKE DISC INSPECTION

Inspect the rear brake disc in the same manner as the front brake disc. (C79-70)

Service Limit

Rear disc thickness: 5.0 mm (0.20 in)

Rear disc runout: 0.30 mm (0.012 in)

- * Brake disc removal (C79-49)
- * Brake disc installation (C79-64)

MASTER CYLINDER REMOVAL AND DISASSEMBLY

Remove and disassemble the rear master cylinder in the same manner as the front brake master cylinder. (C79-70)

MASTER CYLINDER INSPECTION (C79-71)

MASTER CYLINDER REASSEMBLY AND REMOUNTING

Reassemble and remount the master cylinder in the reverse order of removal and disassembly. Pay attention to the following points:

CAUTION

- * Wash the master cylinder components with fresh brake fluid before reassembly. Never use cleaning solvent or gasoline to wash them.
- * Do not wipe the components with a rag.
- * Apply brake fluid to the cylinder bore and all the component to be inserted into the bore.

Specification and Classification: DOT 4

- Apply brake fluid to the piston/cup set.
- Install the following parts to the master cylinder.
 - ① Dust boot
 - ② Snap ring
 - ③ Secondary cup
 - ④ Piston
 - ⑤ Primary cup
 - ⑥ Return spring

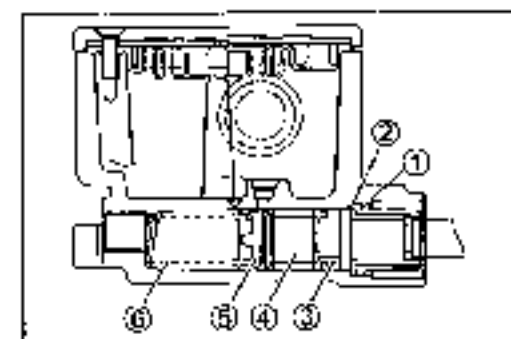
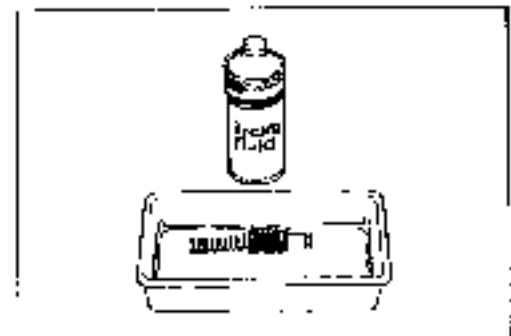

When remounting the brake master cylinder onto the handlebars, align the master cylinder holder's mating surface (A) with the punch mark (B) on the handlebars and tighten the upper bolt (C) first.

- Master cylinder mounting bolt:**
 10 N·m (1.0 kgf-m, 7.0 lb-ft)



- After touching the brake hose union pipe to the stopper, tighten the brake hose union bolt to the specified torque.

- Brake hose union bolt: 23 N·m (2.3 kgf-m, 16.5 lb-ft)**

CAUTION

- * The seal washers should be replaced with the new ones to prevent fluid leakage.
- * Bleed air from the system after reassembling the master cylinder. (☐2-25)



BRAKE LOCK ADJUSTMENT

Before adjusting the brake lock, perform to bleed the air from the rear brake system.

- Pull the brake lock lever by one step (one notch).

NOTE:

- * The brake lock lever has eight steps (eight notches) when pulling in full.
- * When pulling the brake lock lever, first the brake lock switch makes sound, then notch makes a sound. Make a count of notch by sound except the brake lock switch's sound.



- Loosen the locknut (1) and the adjust bolt (2).



- Turn the adjuster bolt (2) clockwise until it stops.
- Tighten the locknut (1) to the specified torque with the adjust bolt (2) held in that position.

Ⓜ Brake lock adjust locknut: 9.5 N·m (0.95 kgf-m, 7.0 lb-ft)

NOTE:

Do not turn the adjust bolt more than the given position, or the adjust bolt may be damaged.

- Inspect the brake lock. (☞ 2-33)

BRAKE LOCK CABLE REPLACEMENT

- Remove the right side leg shield. (☞ 9-12)
- Remove the front box. (☞ 9-18)
- Loosen the locknut (1).
- Disconnect the brake lock cable (2).



- Remove the brake hose clamp on the swingarm.



- Remove the locknut (3).
- Remove the brake lock arm (4) from the caliper.



- Disconnect the brake lock cable (5) by removing the E-ring (6).

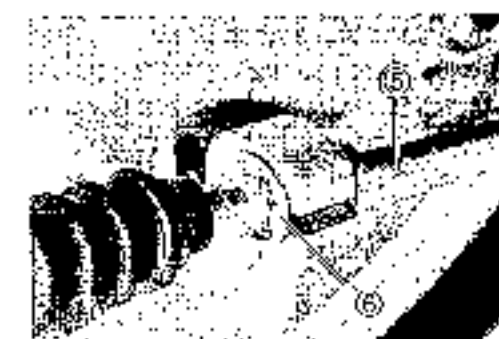

- Install the brake lock cable (CABLE ROUTING: 11-18)
- Turn the nut (7) until the clearance is 0 mm (0 in).

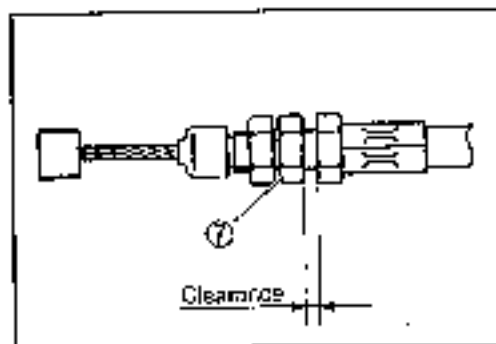

- Connect the brake lock cable to the brake lock lever assembly.
- Fit the nut (8) into the concavity on the brake lock lever assembly
- Tighten the locknut (9) securely.
- Be sure to fit the boot (10) on the brake lock cable.



- Connect the brake lock cable and install the E-ring (11).
- Be sure to fit the dust boots (12) on the brake lock cable.

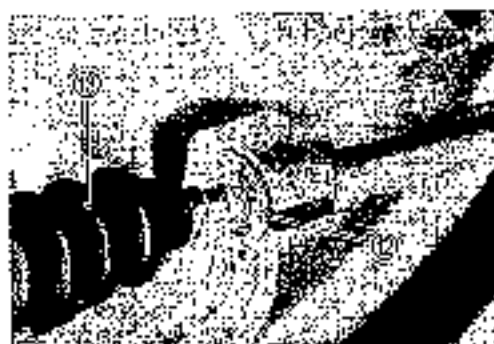

- Install the brake lock arm (14). (C/F 9-82)

NOTE:

The open end of spring (13) must face to the right side of vehicle.



- Install the brake hose clamp.
- Adjust the brake lock. (C/F 9-84)
- Install the front box and right leg side shield.



BRAKE-LOCK SYSTEM

BRAKE-LOCK OPERATION

The brake-lock arm turns through the brake-lock cable as soon as pulling the brake-lock lever. The turning movement is converted to axial movement by the brake-lock adjuster connected to the body with the thread (A). The axial movement transmits automatically from sleeve piston to adjust-bolt. The adjust-bolt presses brake pad to brake disk through the adjust-nut/caliper piston. In this bout, the adjust-bolt and adjust-nut move together with the relation as shown in the illustration.

When releasing the brake-lock lever, each parts return to home position, the caliper piston will be returned by an elasticity transform of piston seal, the adjust-bolt will be returned by the adjust-bolt spring, the brake-lock adjuster will be returned by the return-spring.

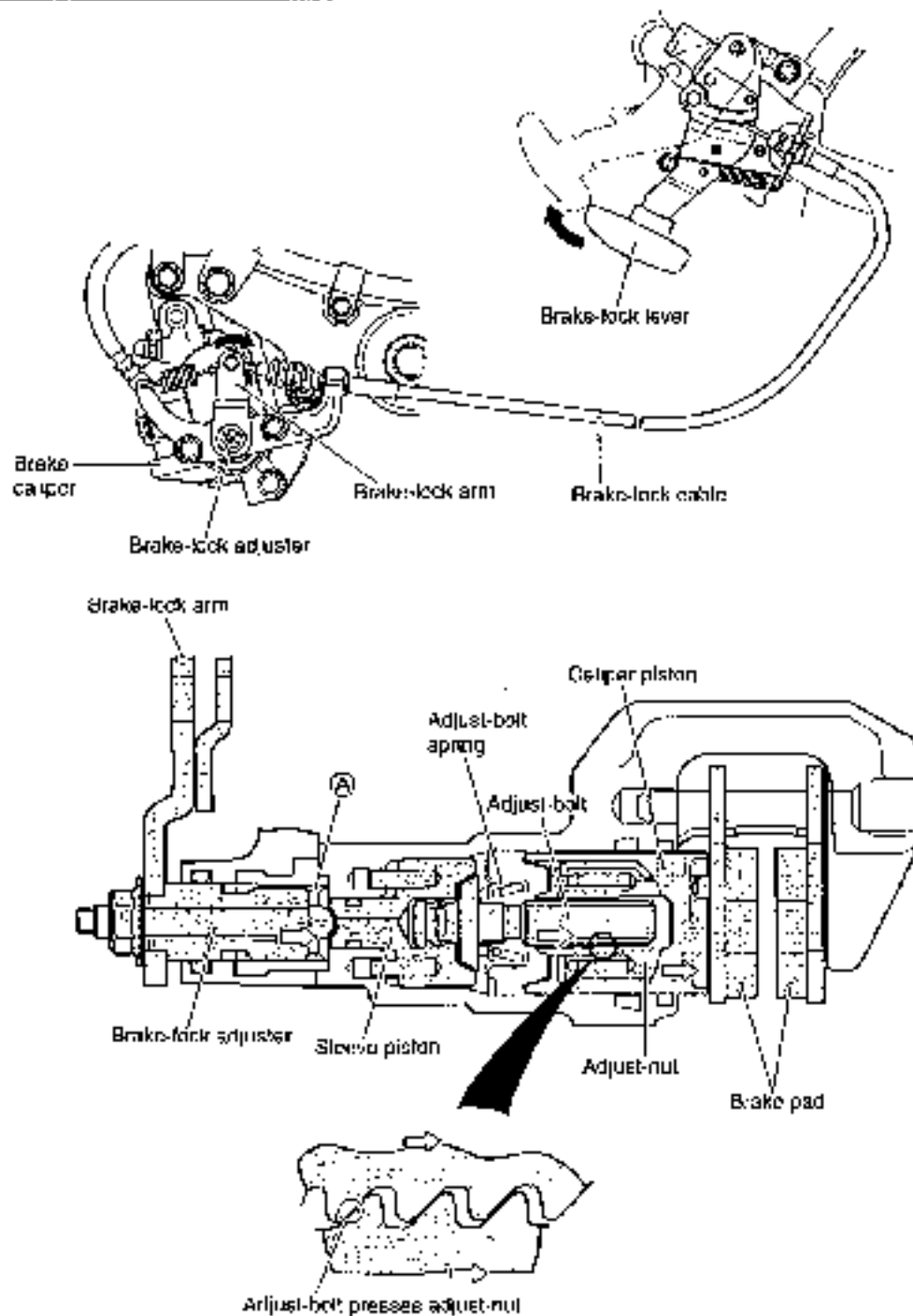

AUTOMATIC BRAKE-LOCK ADJUSTER SYSTEM

The automatic brake-lock adjuster system is equipped on the brake-lock. If the brake pad worn, the adjust-bolt/nut adjust the position of caliper piston so as to keep the certain clearance between brake pad and brake disk.

OPERATION (Normal condition→Braking)

The hydraulic pressure by brake lever operation acts on the adjust-nut/caliper piston. The adjust-bolt threads and adjust-nut threads have a clearance. The piston stroke when braking is shorter than clearance, thus, the braking operation will finish without automatic brake-lock adjuster system operation.

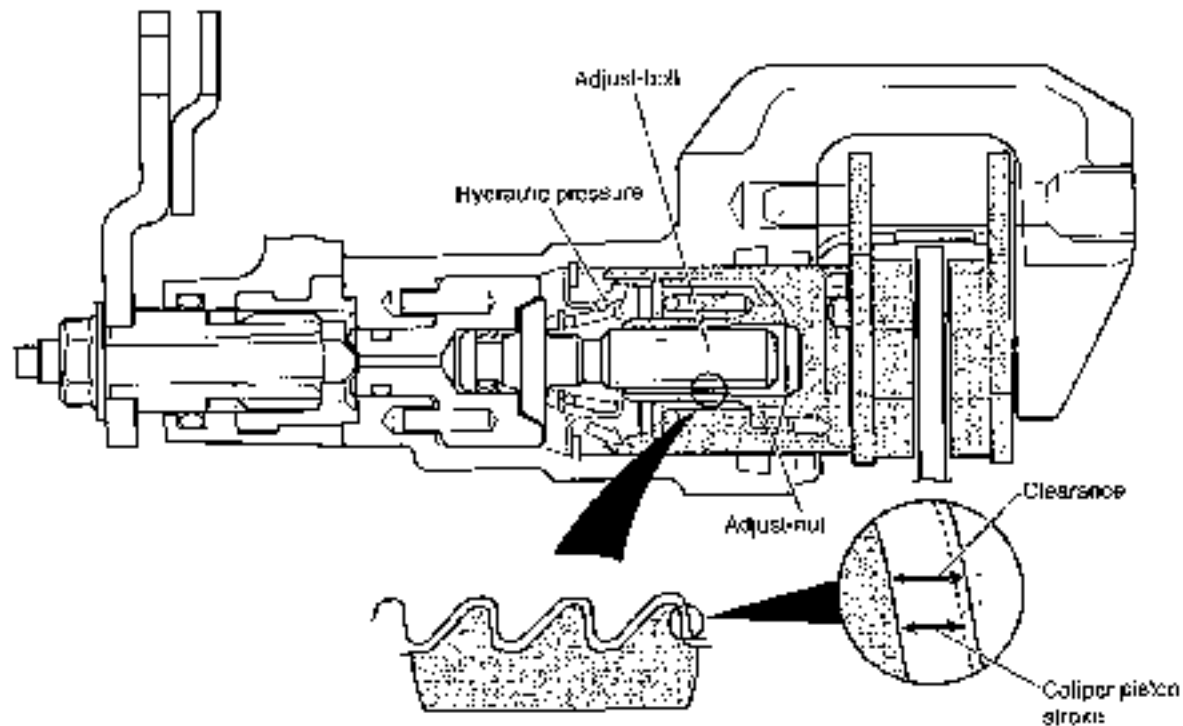

OPERATION (Brake pads are worn → Braking → Automatic adjuster operate)

If braking when the brake pad being worn, the caliper piston/adjust-nut move [1] until the clearance depended on abrasion is done away.

The axial movement [2] is converted to rotary movement and acts on the adjust-bolt and adjust-nut. Only the adjust-bolt turns [3] because the caliper piston/adjust-nut is fixed to the brake pad with caliper piston groove and pad boss at A. Thus, the adjust-bolt keeps original position with rotating as well as the caliper piston/adjust-nut moves outside.

The adjust-bolt stops rotating once the brake pad-to-disc clearance become zero, so the automatic adjuster operation is completed.

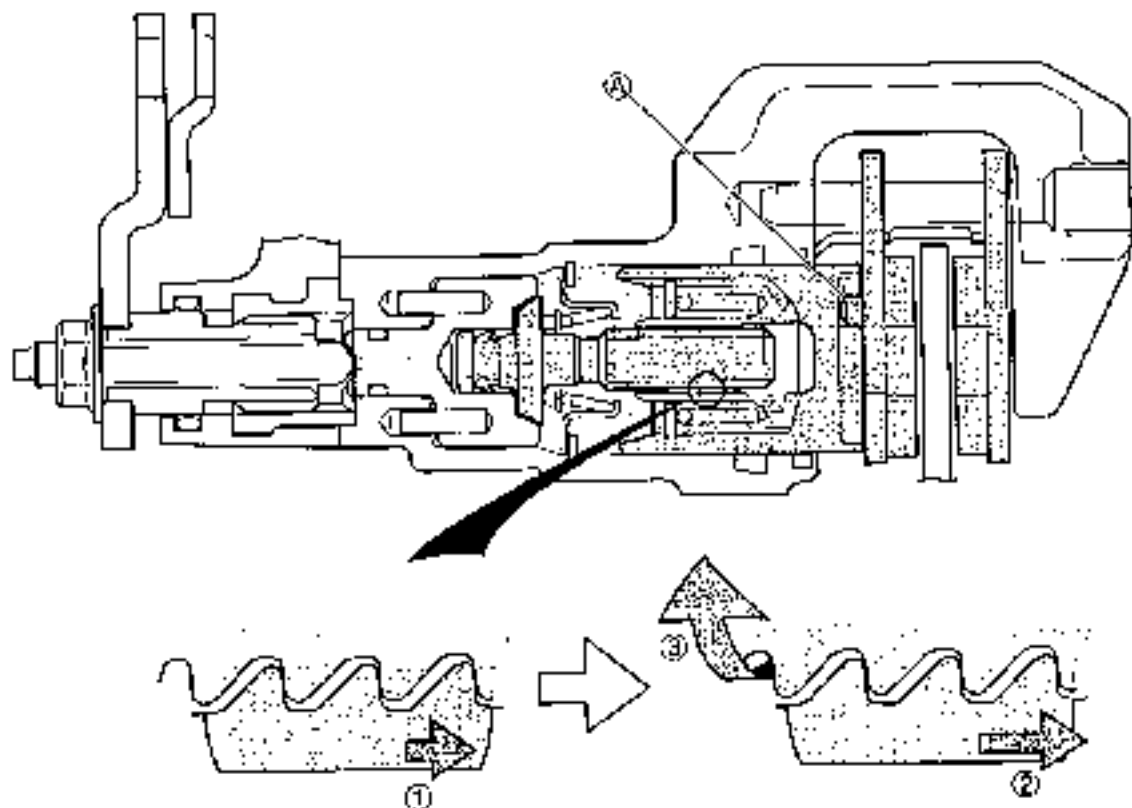

OVER-ADJUST PREVENTION MECHANISM

When rapid braking (①), the automatic brake-lock adjuster operation works too fast (②).

The caliper piston/adjust-nut is forced to stop (③) as soon as the brake pad contacts with brake disk, but the adjust-bolt turns by inertia force (④) after that. The adjust-bolt stops after the adjust-bolt/nut clearance becomes zero. On this account, the caliper piston/adjust-nut can not return back (⑤) using the elasticity transform of piston seal when releasing the brake lever. It is the over-adjust condition.

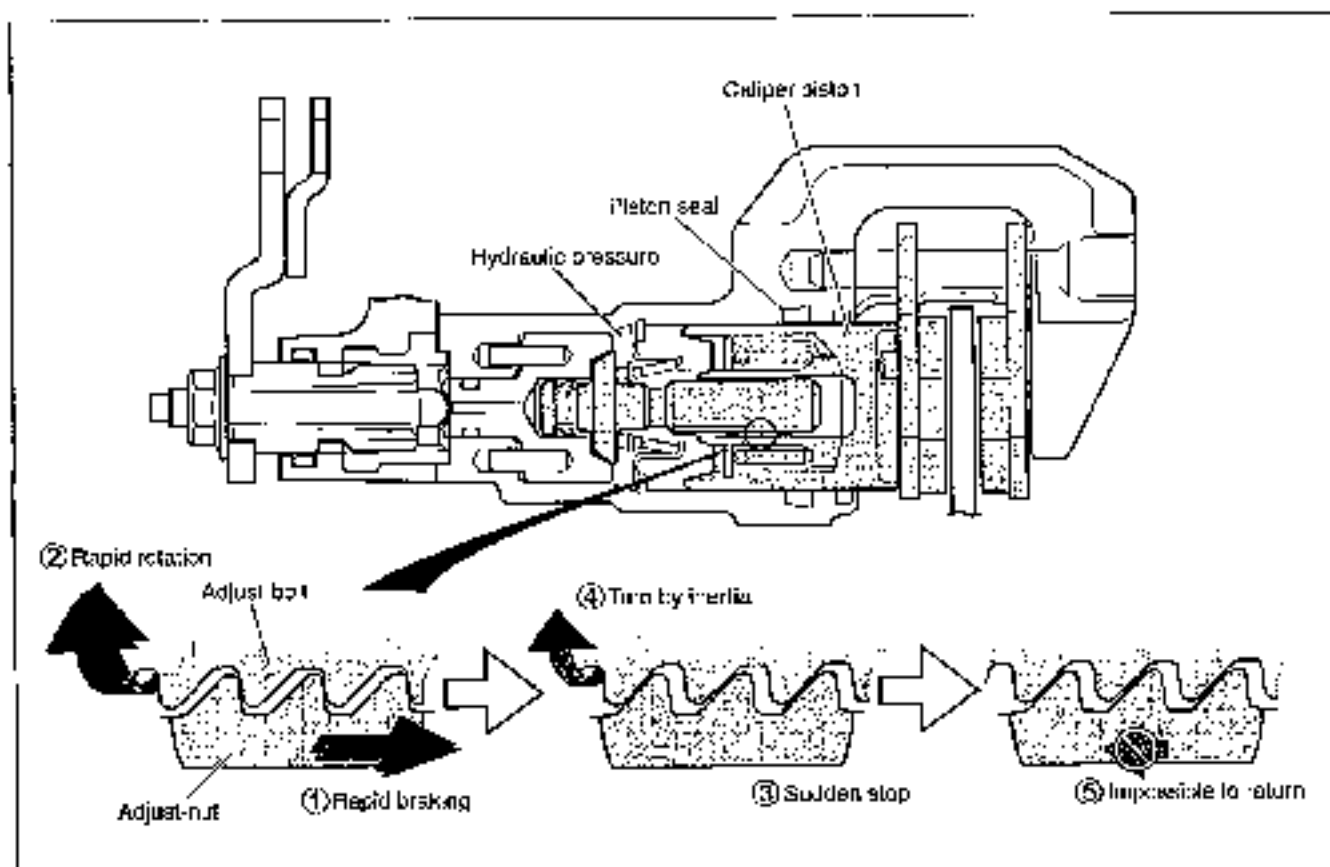

The spring is equipped between the caliper piston and the adjust-nut for preventing the over-adjust, serves damper intern of rapid caliper piston movement.

The spring compress (②) as soon as the caliper piston moves exponentially (①), the adjust-nut moves (③), (④) behind time. Here with, it is possible to make correct clearance of the adjust-bolt/nut because the inertia force with rapid movement does not work the adjust-bolt.

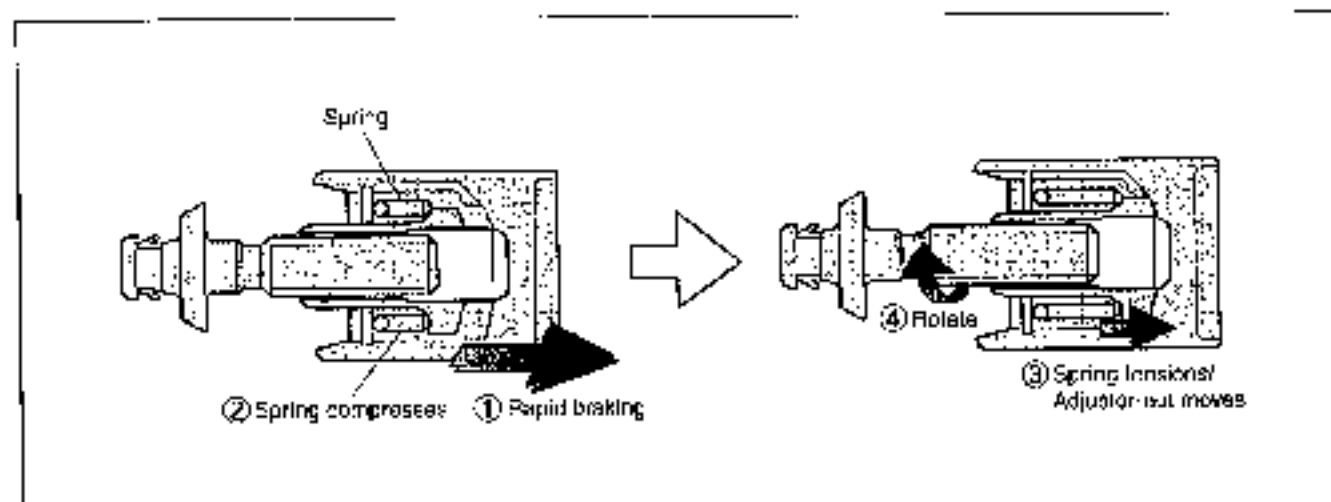

TIRE AND WHEEL

TIRE REMOVAL

The most critical factor of a tubeless tire is the seal between the wheel rim and the tire bead. For this reason, it is recommended to use a tire changer that can satisfy this sealing requirement and can make the operation efficient as well as functional.

For operating procedures, refer to the instructions supplied by the tire changer manufacturer.

NOTE:

When removing the tire in the case of repair or inspection, mark the tire with a chalk to indicate the tire position relative to the valve position.

Even though the tire is refitted to the original position after repairing a puncture, the tire may have to be balanced again since such a repair can cause imbalance.

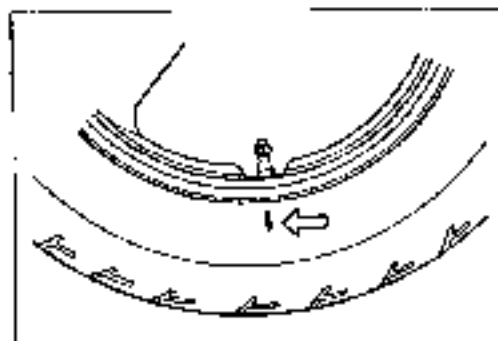

INSPECTION

WHEEL

Wipe the wheel clean and check for the following:

- Distortion and crack
- Any flaws and scratches at the bead seating area.
- Wheel rim runout (C/F 9-27)

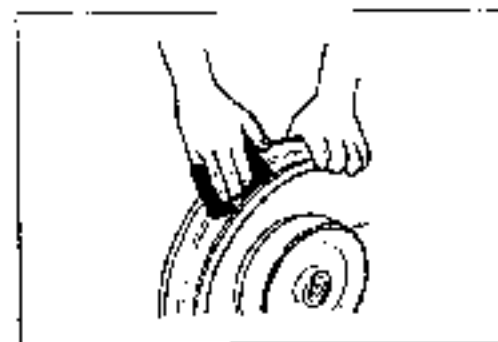

TIRE

Tire must be checked for the following points:

- Nick and rupture on side wall
- Tire tread depth (C/F 2-25)
- Tread separation
- Abnormal, uneven wear on tread
- Surface damage on bead
- Localized tread wear due to skidding (Flat spot)
- Abnormal condition of inner liner

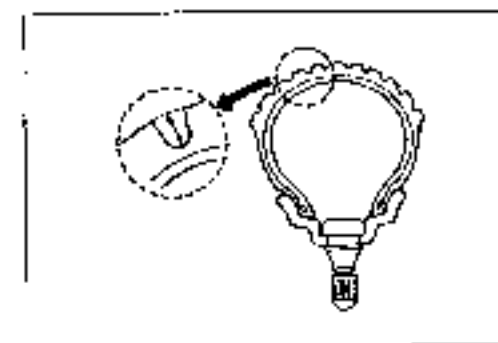
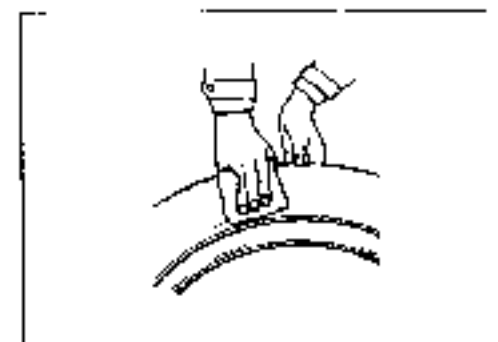

VALVE

- Inspect the valve after the tire is removed from the rim. Replace the valve with a new one if the seal rubber is peeling or has damage.
- Inspect the valve core. If the seal has abnormal deformation, replace the valve with a new one.

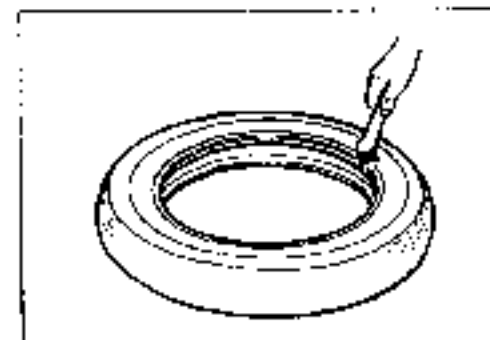
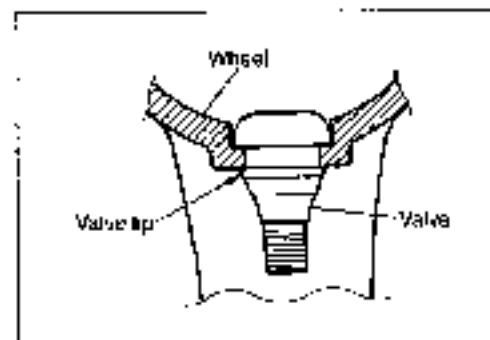
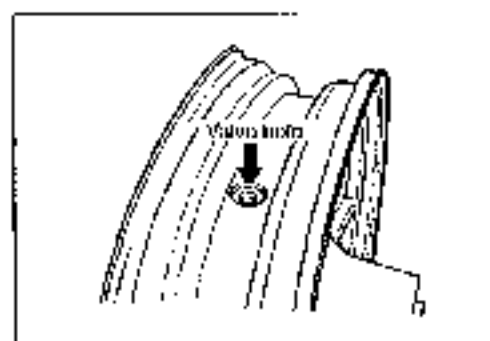
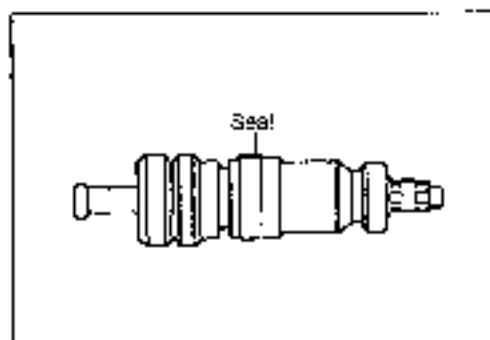
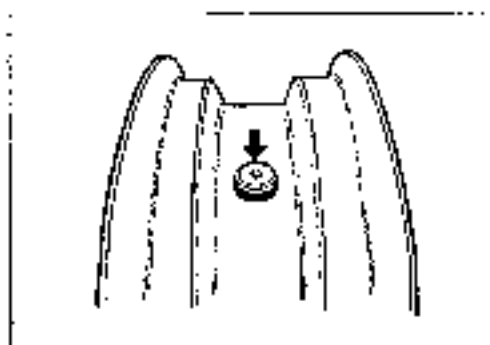
**VALVE INSTALLATION**

- Any dust or rust around the valve hole must be cleaned off. Then install the valve in the rim.

NOTE:

To properly install the valve into the valve hole, apply a special tire lubricant or neutral soapy liquid to the valve.

CAUTION

Be careful not to damage the lip of valve.

TIRE INSTALLATION

- Apply tire lubricant to the tire bead.
- When installing the tire onto the wheel, observe the following points.

CAUTION

- Do not reuse the valve which has been once removed.
- Do not use oil, grease or gasoline on the tire bead in place of tire lubricant.

- When installing the tire, the arrow ① on the side wall should point to the direction of wheel rotation.
- Align the chalk mark put on the tire at the time of removal with the valve position.

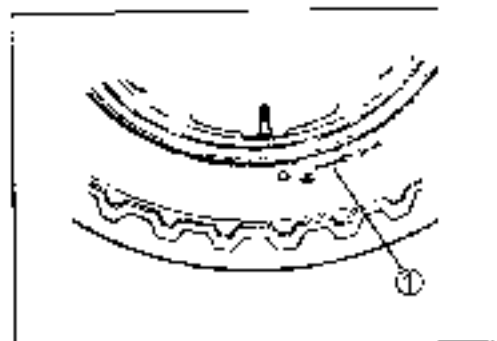

- For installation procedure of tire onto the wheel, follow the instructions given by the tire changer manufacturer.
- Bounce the tire several times while rotating. This makes the tire bead expand outward to contact the wheel, thereby facilitating air inflation.
- Inflate the tire.

▲ WARNING

- Do not inflate the tire to more than 400 kPa (4.0kgf/cm²). If inflated beyond this limit, the tire can burst and possibly cause injury. Do not stand directly over the tire while inflating.
- In the case of preset pressure air inflator, pay special care for the set pressure adjustment.

- In this condition, check the "rim line" cast on the tire side walls. The line must be equidistant from the wheel rim all around. If the distance between the rim line and wheel rim varies, this indicates that the bead is not properly seated. If this is the case, deflate the tire completely and unseat the bead for both sides. Coat the bead with lubricant and fit the tire again.
- When the bead has been fitted properly, adjust the pressure to specification. (☐ 2-26)
- As necessary, adjust the tire balance.

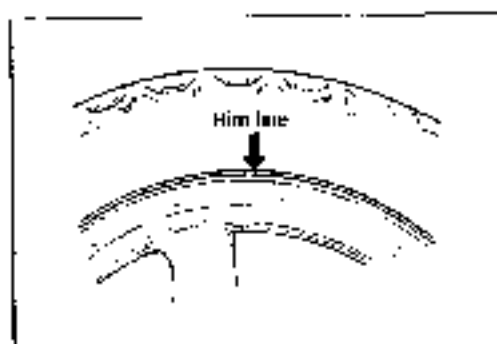

CAUTION

Do not run with a repaired tire at a high speed.

BALANCER WEIGHT INSTALLATION

- When installing the balancer weights to the wheel, set the two balancer weights on both sides of wheel rim.

CAUTION:

Weight difference between the two balancer weights must be less than 10 g.

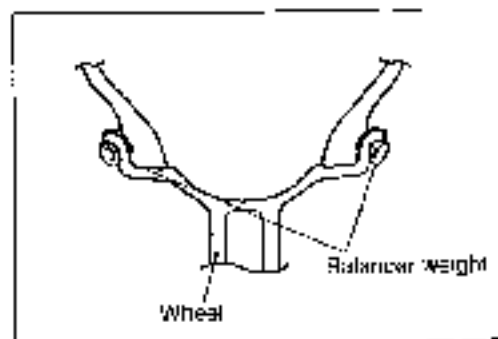

ELECTRICAL SYSTEM

CONTENTS

CAUTIONS IN SERVICING	10- 2
CONNECTORS	10- 2
COUPLERS	10- 2
CLAMPS	10- 2
FUSES	10- 2
SEMI-CONDUCTOR EQUIPPED PARTS	10- 2
BATTERY	10- 3
CONNECTING THE BATTERY	10- 3
WIRING PROCEDURE	10- 3
USING THE MULTI CIRCUIT TESTER	10- 3
LOCATION OF ELECTRICAL COMPONENTS	10- 4
CHARGING SYSTEM	10- 6
TROUBLESHOOTING	10- 6
INSPECTION	10- 8
STARTER SYSTEM	10-11
TROUBLESHOOTING	10-11
STARTER MOTOR REMOVAL AND DISASSEMBLY	10-12
STARTER MOTOR INSPECTION	10-13
STARTER MOTOR REASSEMBLY	10-14
STARTER RELAY INSPECTION	10-15
SIDE-STAND/IGNITION INTERLOCK SYSTEM PARTS	
INSPECTION	10-16
IGNITION SYSTEM	10-18
TROUBLESHOOTING	10-18
INSPECTION	10-20
COMBINATION METER	10-23
PARTS NAMES	10-23
REMOVAL AND DISASSEMBLY	10-23
OPERATING PROCEDURE	10-24
INSPECTION	10-26
LAMP	10-31
HEADLIGHT	10-31
BRAKE LIGHT/ TAILLIGHT, TURN SIGNAL LIGHT AND	
LICENSE LIGHT	10-32
RELAYS	10-34
TURN SIGNAL RELAY	10-34
COOLING FAN MOTOR RELAY	10-34
FUEL PUMP RELAY	10-34
SIDE-STAND RELAY	10-34
STARTER RELAY	10-34
SWITCHES	10-34
IGNITION SWITCH REMOVAL	10-34
BATTERY	10-37
SPECIFICATIONS	10-37
INITIAL CHARGING	10-37
SERVICING	10-39
RECHARGING OPERATION	10-39

CAUTIONS IN SERVICING

CONNECTORS

- When disconnecting a connector, be sure to hold the terminals; do not pull the lead wires.
- When connecting a connector, push it in so it is firmly attached.
- Inspect the connector for corrosion, contamination and any breakage in the cover.

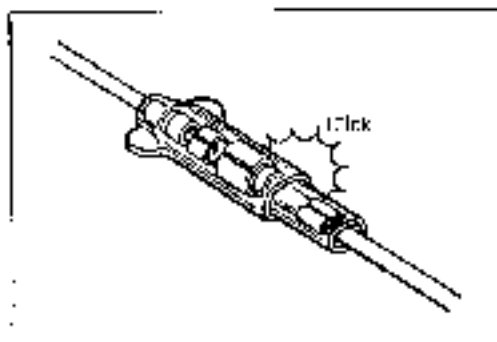

COUPLERS

- With a lock-type coupler, be sure to release the lock before disconnecting it. When connecting a coupler, push it in until the lock clicks shut.
- When disconnecting a coupler, be sure to hold the coupler; do not pull the lead wires.
- Inspect each terminal on the coupler for looseness or bonds.
- Inspect each terminal for corrosion and contamination.

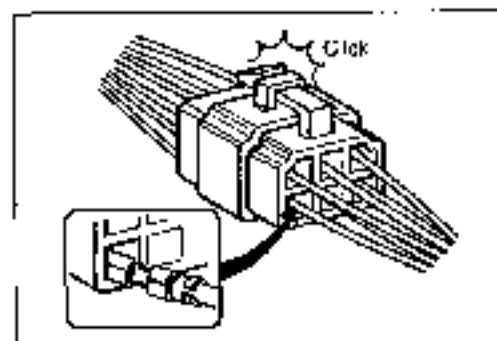

CLAMPS

- Refer to the "WIRING HARNESS ROUTING" section for proper clamping procedures. (11-14 to 11-17)
- Bend the clamp properly, as shown in the illustration.
- When clamping the wire harness, do not allow it to hang down.
- Do not use wire or any substitutes for the band-type clamp.

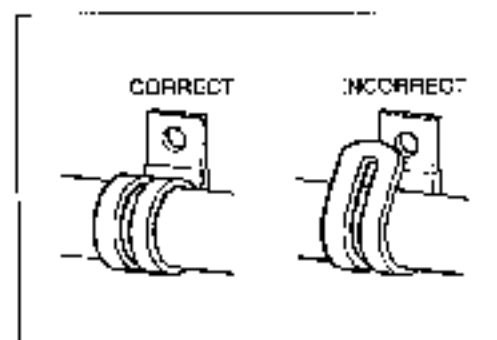

FUSES

- When a fuse blows, always investigate the cause, correct the problem, and then replace the fuse.
- Do not use a fuse of a different capacity.
- Do not use any substitutes for the fuse (e.g., wire).

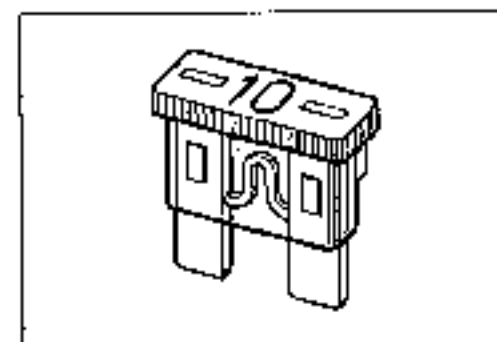

SEMI-CONDUCTOR EQUIPPED PARTS

- Do not drop any part that contains a semi-conductor (e.g., ECM, CVT control unit, regulator/rectifier).
- When inspecting the part, follow the inspection instructions carefully. Neglecting proper procedures may cause this part to be damaged.

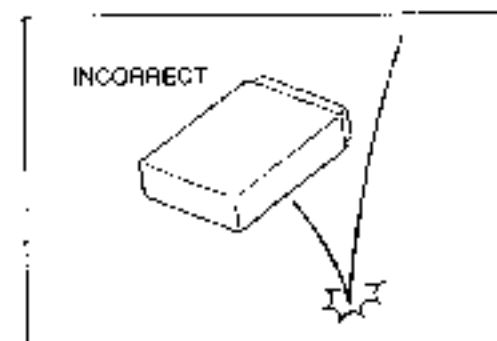

BATTERY

- The MF battery used in this motorcycle does not require maintenance (e.g., electrolyte level inspection, distilled water replenishment).
- During normal charging, no hydrogen gas is produced. However, if the battery is overcharged, hydrogen gas may be produced. Therefore, be sure there are no fire or spark sources (e.g., short circuit) nearby when charging the battery.
- Be sure to recharge the battery in a well-ventilated and open area.
- Note that the charging system for the MF battery is different from that of a conventional battery. Do not replace the MF battery with a conventional battery.

CONNECTING THE BATTERY

- When disconnecting terminals from the battery for disassembly or servicing, be sure to disconnect the (-) battery lead wire, first.
- When connecting the battery lead wires, be sure to connect the (+) battery lead wire, first.
- If the terminal is corroded, remove the battery, pour warm water over it and clean it with a wire brush.
- After connecting the battery, apply a light coat of grease to the battery terminals.
- Install the cover over the (+) battery terminal.

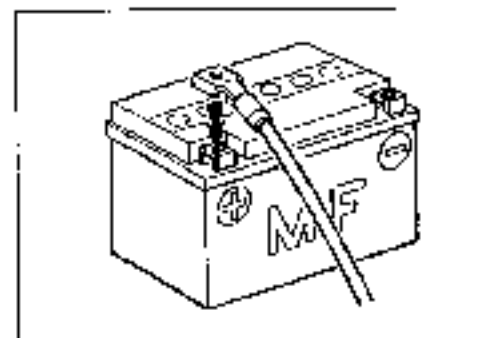
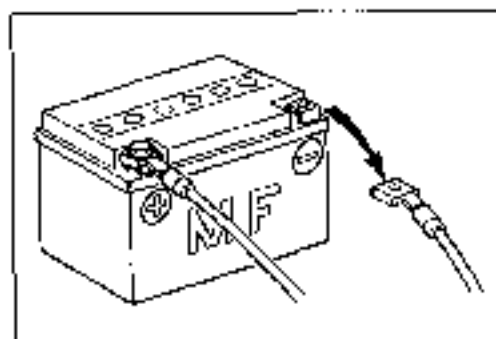

WIRING PROCEDURE

- Properly route the wiring harness according to the "WIRING HARNESS ROUTING" section. (11-11 to 11-17)

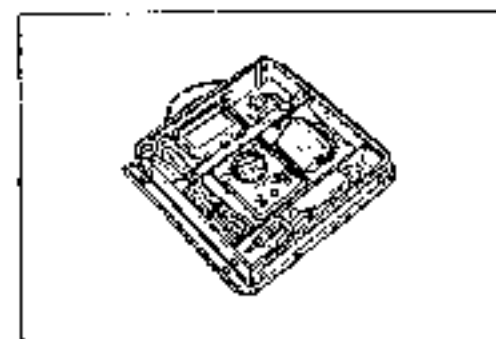

USING THE MULTI CIRCUIT TESTER

- Properly use the multi circuit tester (+) and (-) probes. Improper use can cause damage to the motorcycle and tester.
- If the voltage and current values are not known, begin measuring in the highest range.
- When measuring the resistance, make sure no voltage is applied. If voltage is applied, the tester will be damaged.
- After using the tester, be sure to turn the switch to the OFF position.

CAUTION

Before using the multi circuit tester, read its instruction manual.

LOCATION OF ELECTRICAL COMPONENTS

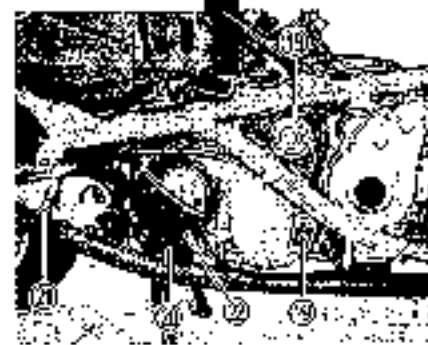
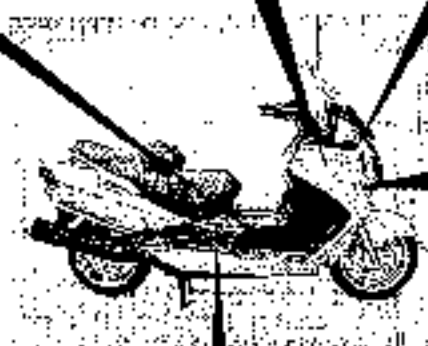
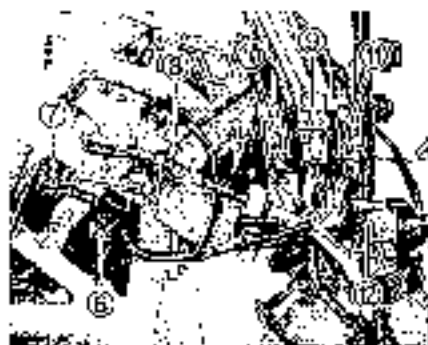
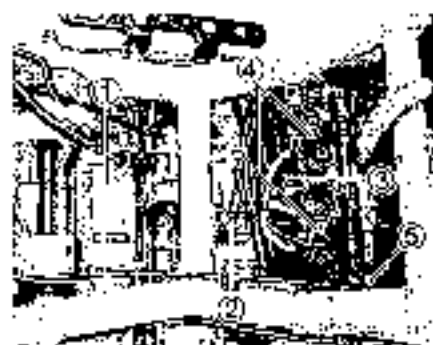

- ① Starter motor
- ② Engine coolant temp. sensor (CFR-13)
- ③ IAC valve (CFR-20)
- ④ Injector (CFR-40)
- ⑤ Throttle position sensor (CFR-31)
- ⑥ Intake air temp. sensor (CFR-30)
- ⑦ Intake air pressure sensor (CFR-29)
- ⑧ Brake lock switch
- ⑨ Cooling fan motor relay
- ⑩ Side-stand relay or Fuel pump relay
- ⑪ Fuel pump relay or Side-stand relay

- ⑫ Atmospheric pressure sensor (CFR-37)
- ⑬ TD sensor (CFR-39)
- ⑭ CVT control unit
- ⑮ FCM (Frignine Control Module)
- ⑯ Solenoid (CFR-12-6)
- ⑰ Horn
- ⑱ CVT motor (CFR-45)
- ⑲ Pulley position sensor (CFR-47)
- ⑳ Center stand switch
- ㉑ NOX sensor (CFR-42)
- ㉒ CVT secondary pulley revolution sensor (CFR-51)

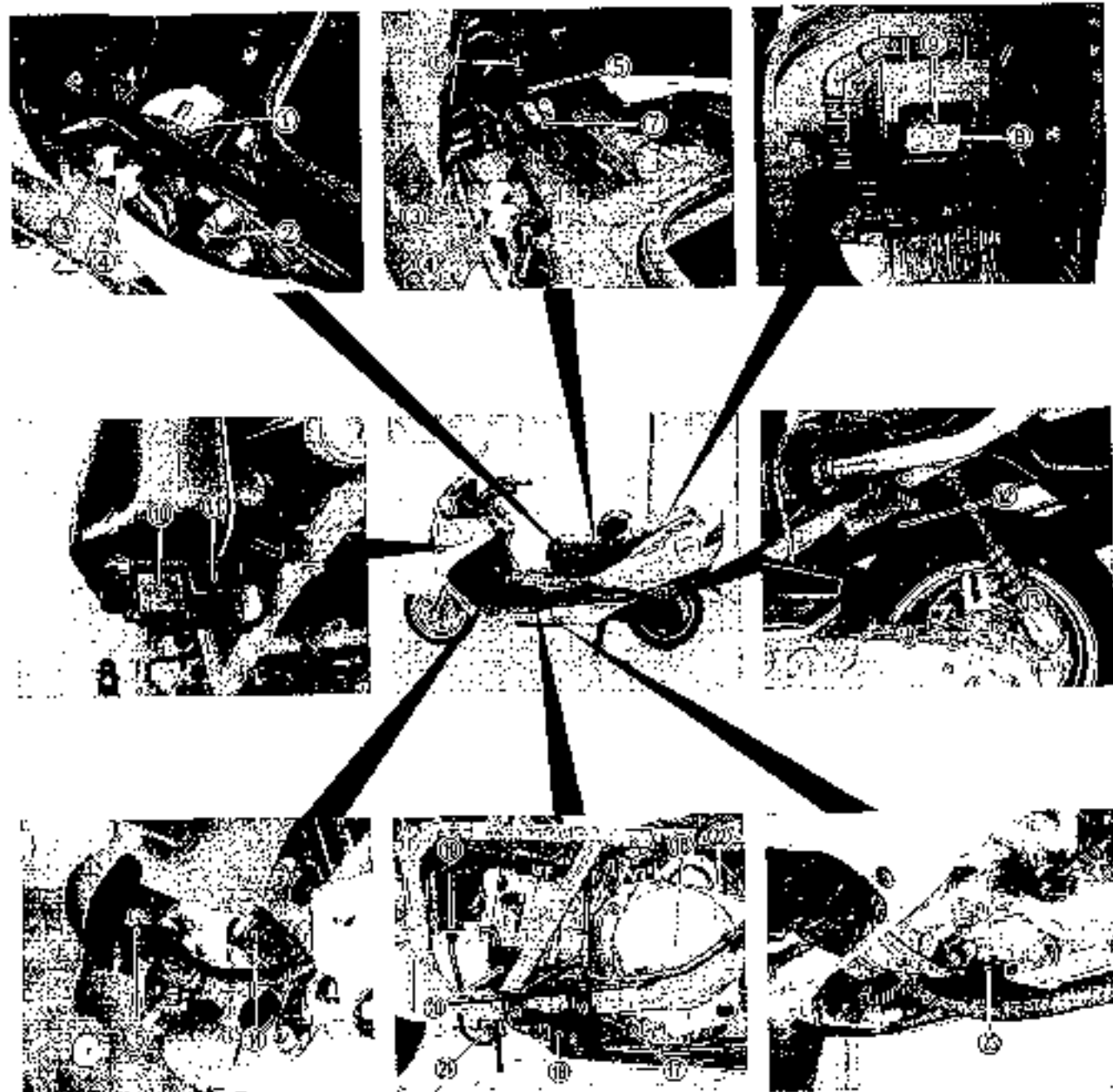

- ① Fuel pump/fuel gauge
- ② Starter relay diode
- ③ Main fuse
- ④ CTV fuse
- ⑤ Battery
- ⑥ Trunk light seat switch
- ⑦ Starter relay
- ⑧ Trunk light
- ⑨ Trunk light switch
- ⑩ Fuse box
- ⑪ Turn signal relay
- ⑫ Regulator/rectifier

- ⑬ Spark plug sensor
- ⑭ Ignition coil/plug cap (#1)
- ⑮ Ignition coil/plug cap (#2)
- ⑯ Generator
- ⑰ Oil pressure switch
- ⑱ Side stand switch
- ⑲ Cam position sensor (C77B-27)
- ⑳ Fan motor (C77B-8)
- ㉑ Cooling fan thermo-switch (C77B-18)
- ㉒ CKP sensor (C77B-28)
- ㉓ Oil level switch

CHARGING SYSTEM

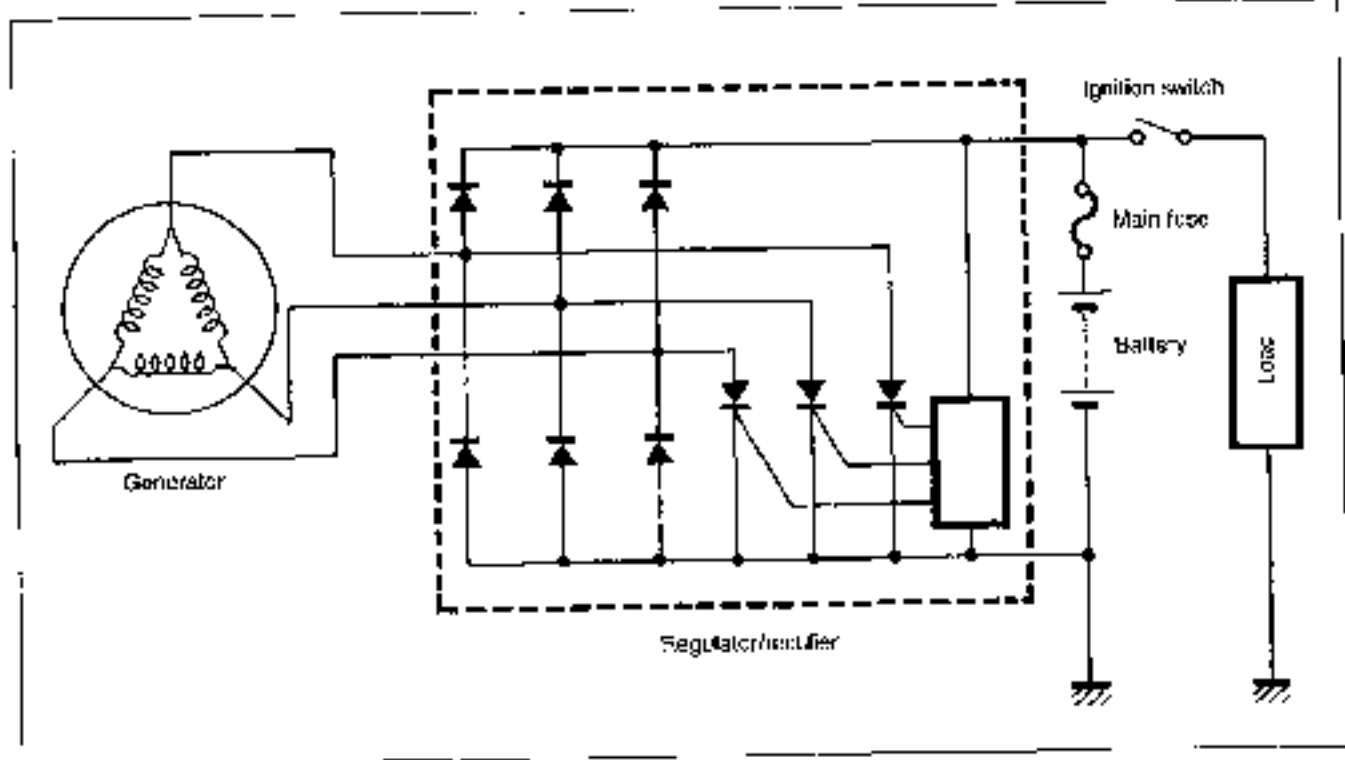

TROUBLESHOOTING

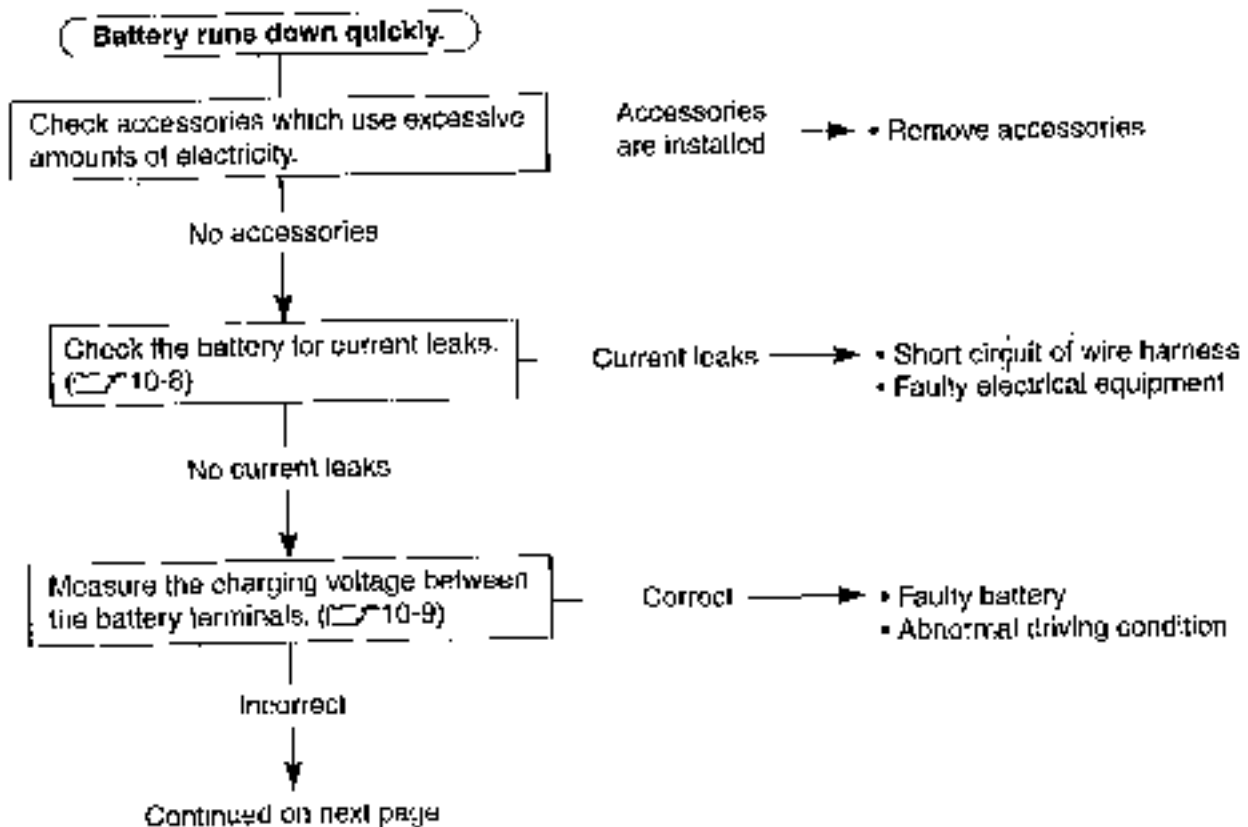

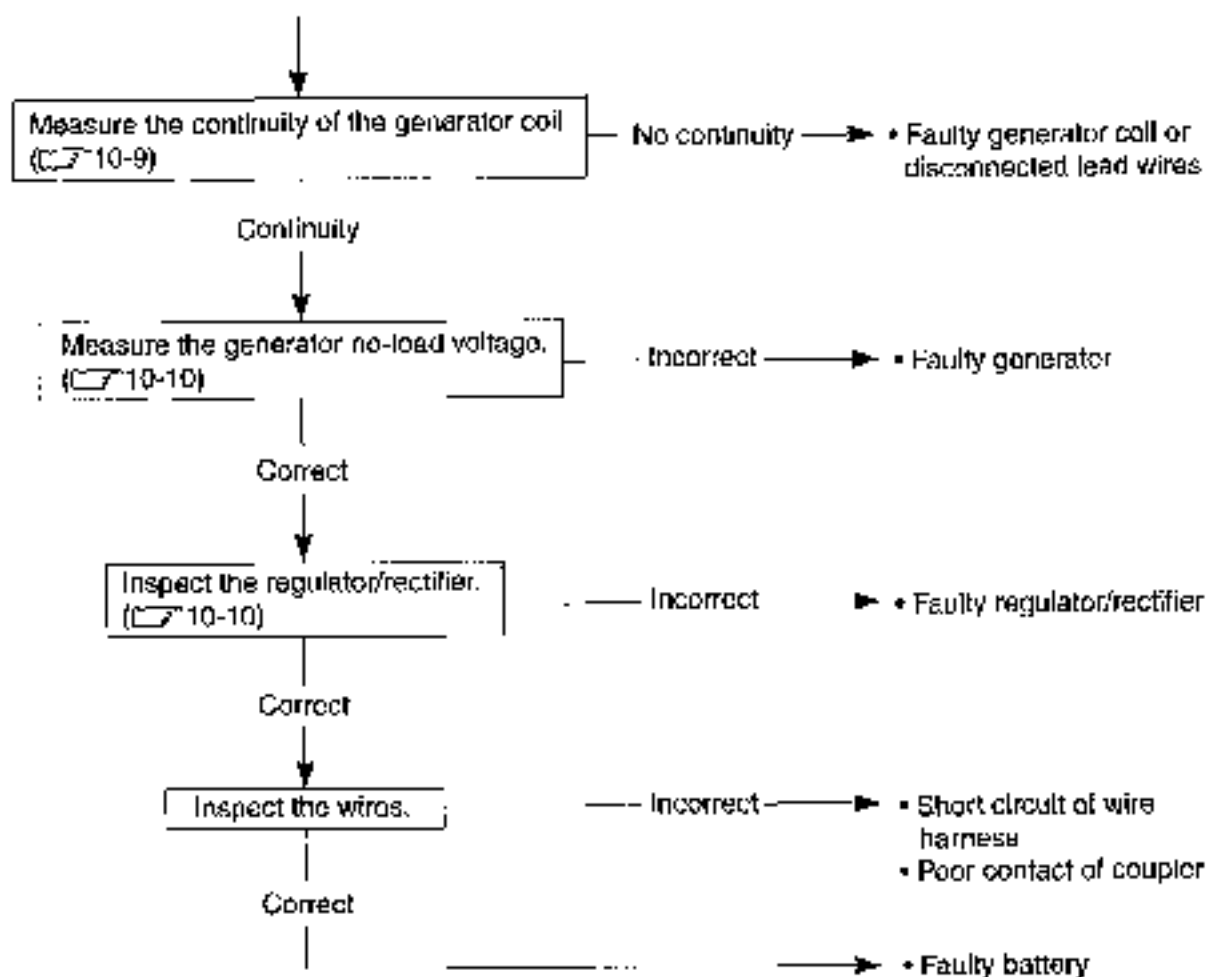

Others

Battery overcharges

- Faulty regulator/rectifier
- Faulty battery
- Poor contact of generator lead wire coupler

INSPECTION

BATTERY CURRENT LEAKAGE

- Open the seat.
- Remove the tool bag.
- Remove the battery cover (1) with starter relay.
- Turn the ignition switch to the "OFF" position.
- Disconnect the (-) battery lead wire (2).

Measure the current between (-) battery terminal and the (-) battery lead wire using the multi circuit tester. If the reading exceeds the specified value, leakage is evident.

 09900-25008: Multi circuit tester set

 Tester knob indication: Current (---, 20 mA)

 DATA Battery current (leak): Under 3.0 mA

CAUTION

- Because the current leak might be large, turn the tester to the high range first to avoid tester damage.
- Do not turn the ignition switch to the "ON" position when measuring current.

When checking to find the excessive current leakage, remove the couplers and connectors, one by one, checking each part.

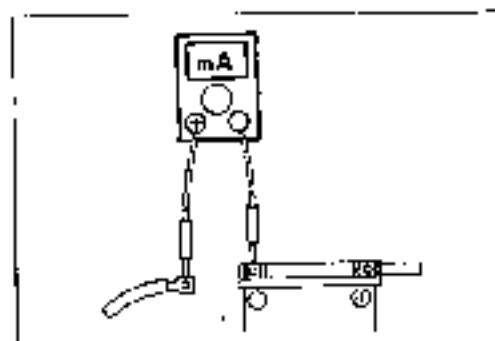

REGULATED VOLTAGE

- Open the seat.
- Remove the battery cover. (☞ 10-8)
- Start the engine, turn the ignition switch to **LIGHT** (☞) (for Italy) and the dimmer switch to **HI** and run the engine at 5 000 r/min.

Measure the DC voltage between the ⊕ and ⊖ battery terminals using the multi circuit tester. If the voltage is not within the specified value, inspect the generator and regulator/rectifier. (☞ 10-9 and 10-10)

NOTE:

When making this test, be sure that the battery is in fully-charged condition.

08900-25008: Multi circuit tester set

Tester knob indication: Voltage (V)

DATA Regulated voltage: 14.0 – 15.5 V at 5 000 r/min

**GENERATOR COIL RESISTANCE**

- Remove the left frame cover. (☞ 9-16)
- Disconnect the generator coupler.

Measure the resistance between the three lead wires.

If the resistance is not specified value, replace the stator coil with a new one.

Also, check that the generator core is insulated.

08900-25008: Multi circuit tester set

Tester knob indication: Resistance (Ω)

**DATA Generator coil resistance: 0.1 – 1.0 Ω (Yellow – Yellow)
∞ Ω (Yellow – Ground)**

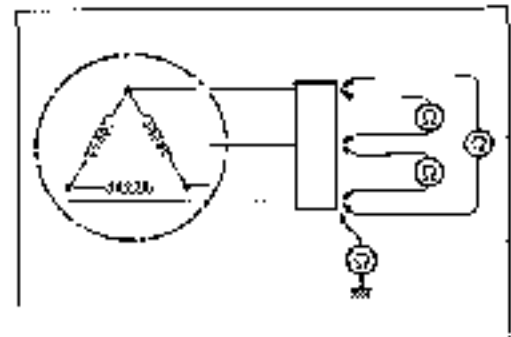

GENERATOR NO-LOAD PERFORMANCE

- Remove the left frame cover. (C-7-9-16)
- Disconnect the generator lead wire coupler.
- Start the engine and run it at 5 000 r/min.

Measure the AC voltage between the lead wires of the generator using the multi circuit tester.

If the voltage is under the specified value, replace the AC generator with a new one.

 09900-25008: Multi circuit tester set

 Tester knob indication: Voltage (-)

DATA Generator no-load performance (when engine is cold):
More than 50 V (AC) at 5 000 r/min

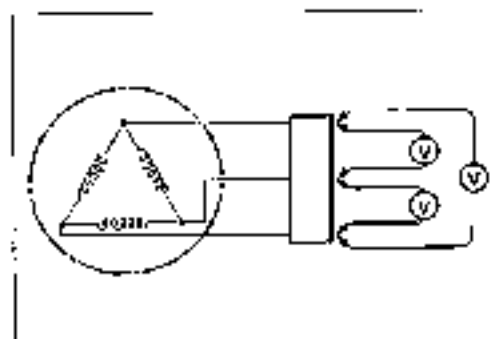
**REGULATOR/RECTIFIER**

- Remove the left frame cover. (C-7-9-16)
- Disconnect the regulator/rectifier couplers (1).

Measure the voltage between the terminals using the multi circuit tester, as indicated in the table below.

If the voltage is not within the specified value, replace the regulator/rectifier with a new one.

 09900-25008: Multi circuit tester set

 Tester knob indication: Diode test (-|-)



Unit: V

Tester probe	Ⓔ Tester probe				
	B/R	B/W	B ₁	B ₂	B ₃
B/R		0.5 - 1.2	0.4 - 0.7	0.4 - 0.7	0.4 - 0.7
B/W	*		*	*	*
B ₁	*	0.4 - 0.7		*	*
B ₂	*	0.4 - 0.7	*		*
B ₃	*	0.4 - 0.7	*	*	

* More than 1.4 V (tester's battery voltage)

NOTE:

If the tester reads under 1.4 V when the tester probes are not connected, replace the battery of multi circuit tester.

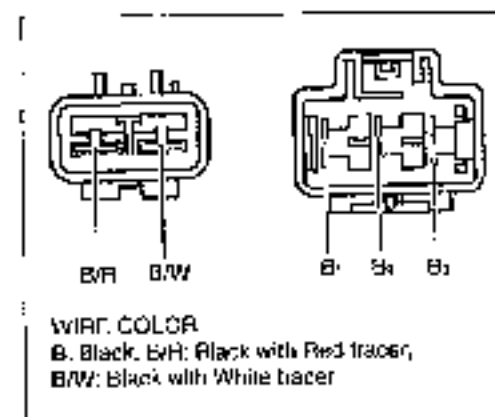

STARTER SYSTEM

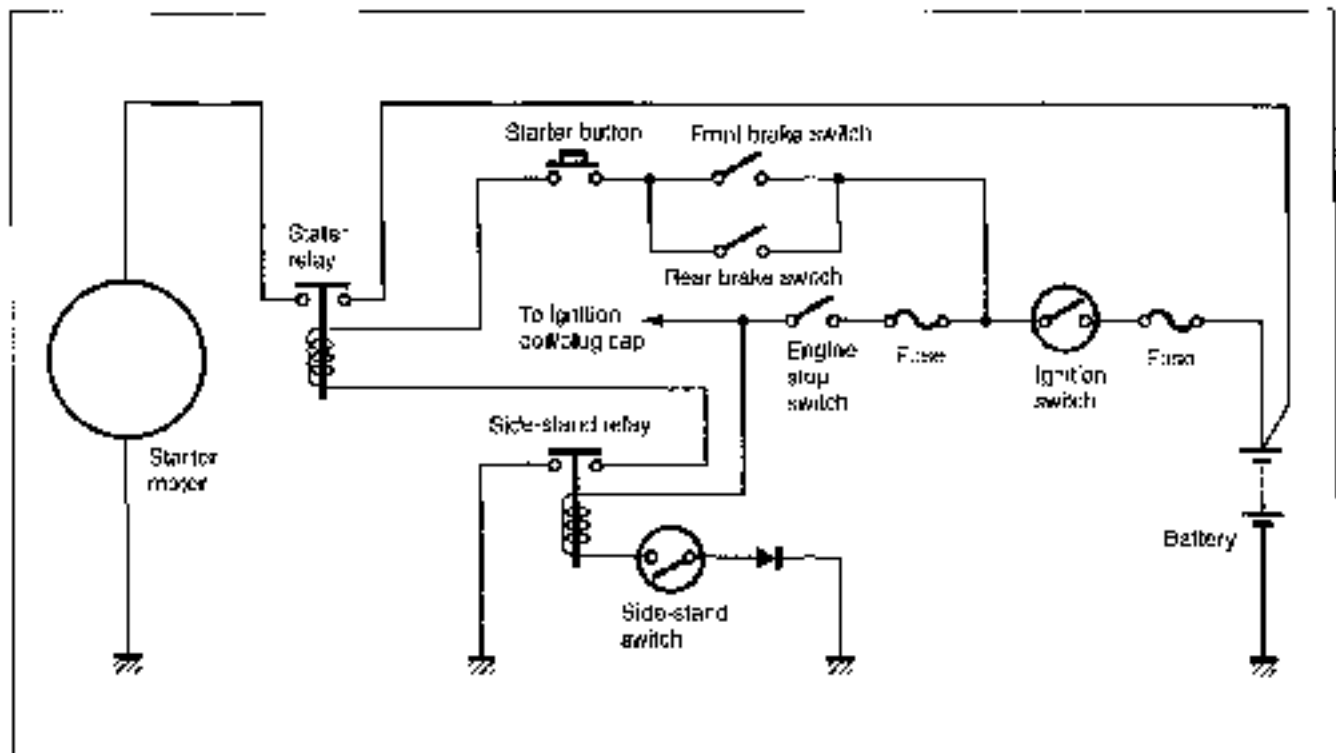

TROUBLESHOOTING

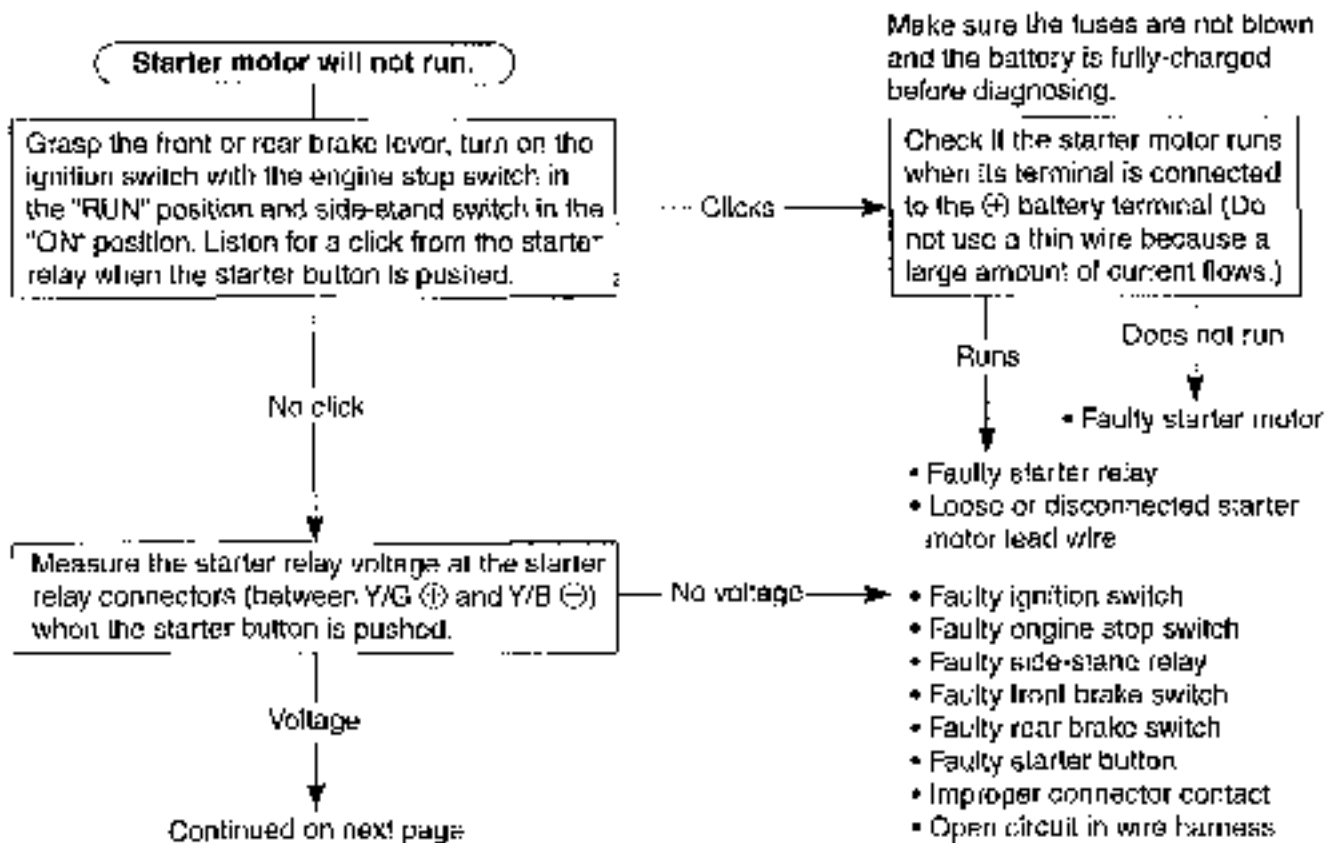

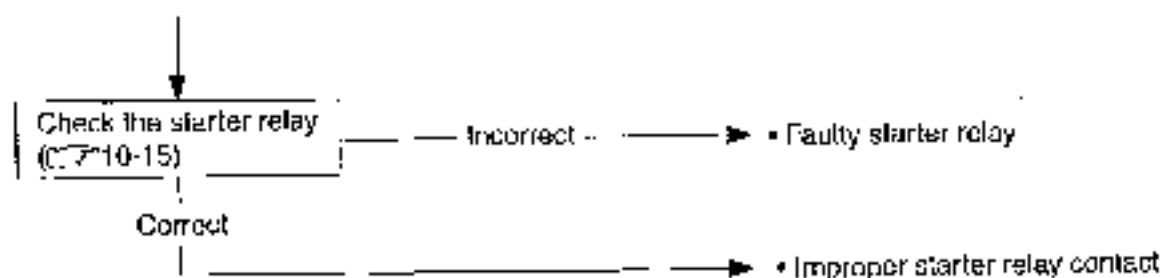

Others

Engine does not turn though the starter motor runs. • Faulty starter clutch

STARTER MOTOR REMOVAL AND DISASSEMBLY

- Remove the foot board. (C/F 9-18)
- Disconnect the starter motor lead wire (1) and remove the starter motor bolts (2).



- Remove the starter motor (3) from the crankcase.
- Turn the starter motor (4) 180° to forward.
- Remove the starter motor.



- Disassembly the starter motor, as shown.

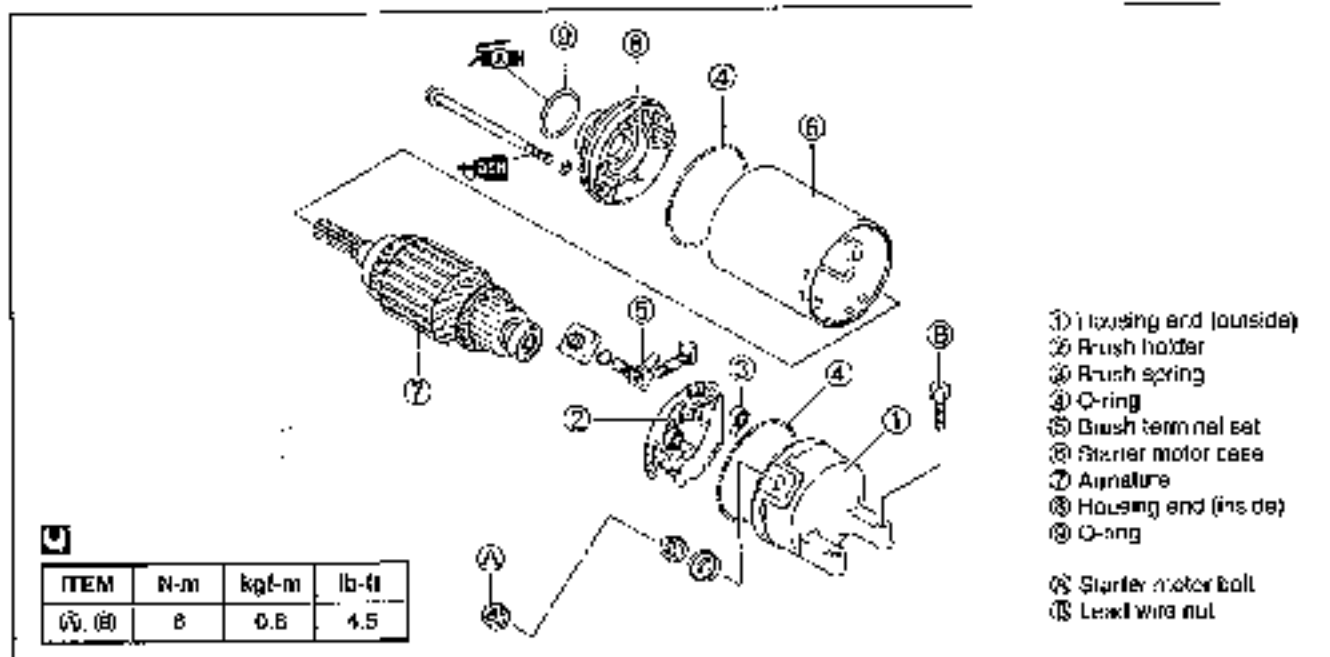

STARTER MOTOR INSPECTION

CARBON BRUSHES

Inspect the carbon brushes for abnormal wear, cracks, or smoothness in the brush holder.

If any damages are found, replace the brush assembly with a new one.

COMMUTATOR

Inspect the commutator for discoloration, abnormal wear or undercut (A).

If abnormal wear is found, replace the armature with a new one.

If the commutator surface is discolored, polish it with #400 sandpaper and wipe it using a clean, dry cloth.

If there is no undercut, scrape out the insulator (B) with a saw blade.

ARMATURE COIL INSPECTION

Check for continuity between each segment and between each segment and the armature shaft using the multi circuit tester.

If there is no continuity between the segments or there is continuity between the segments and shaft, replace the armature with a new one.

 09900-25008: Multi circuit tester set

 Tester knob indication: Continuity test (-H)

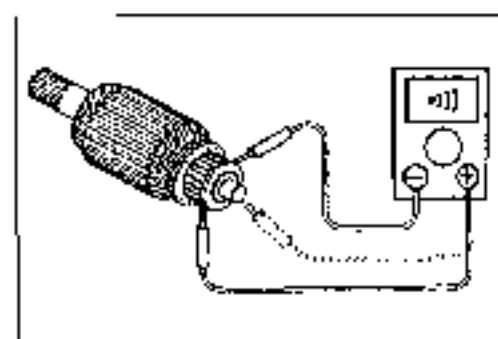
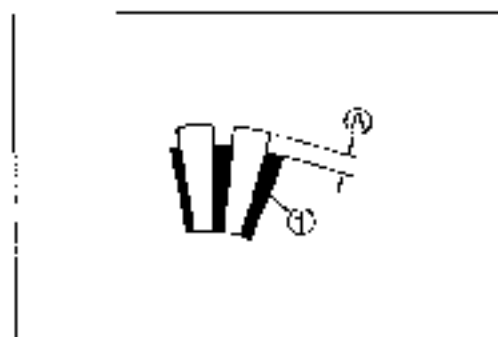
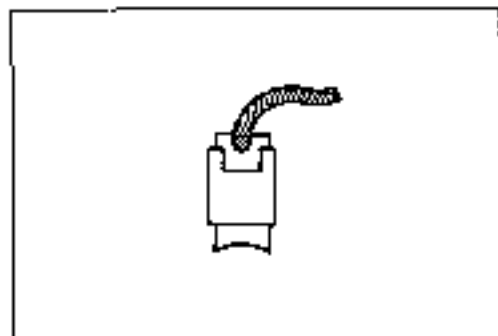

OIL SEAL INSPECTION

Check the oil seal lip for damage or leakage.
If any damage is found, replace the housing end.

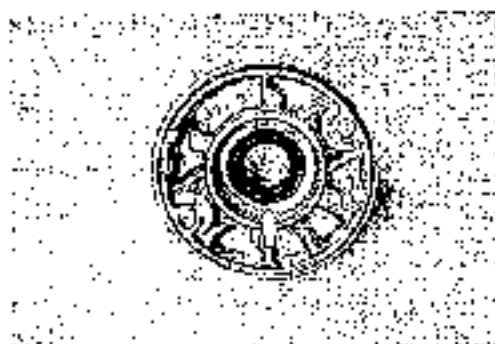

STARTER MOTOR REASSEMBLY

Reassemble the starter motor in the reverse order of disassembly. Pay attention to the following points:

- Apply SUZUKI SUPER GREASE "A" to the lip of the oil seal.

 99000-25030: SUZUKI SUPER GREASE "A" (USA)
99000-25010: SUZUKI SUPER GREASE "A" (Others)

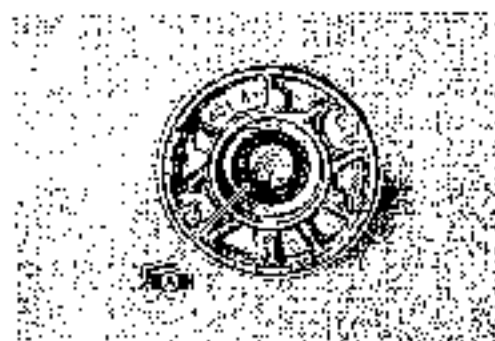

- Align the marks as shown.

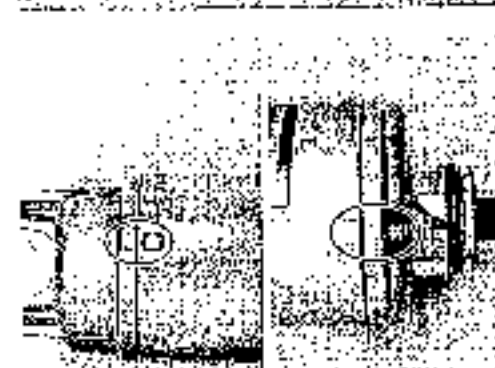

- Apply a small quantity of THREAD LOCK "1342" to the starter motor housing bolts.

 99000-32050: THREAD LOCK "1342"

- Apply SUZUKI SUPER GREASE "A" to the O-ring.

 99000-25030: SUZUKI SUPER GREASE "A" (USA)
99000-25010: SUZUKI SUPER GREASE "A" (Others)

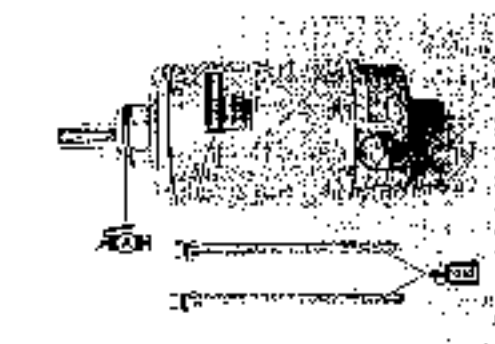

STARTER RELAY INSPECTION

- Open the seat.
- Remove the battery cover. (☞ 10-8)
- Disconnect the battery (+) lead wire from the battery.

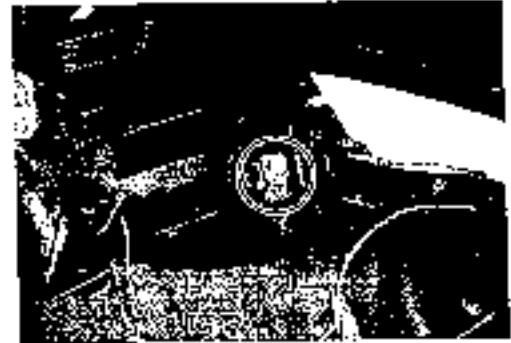

- Disconnect the battery lead wire (1) and starter motor lead wire (2).



- Disconnect the starter relay lead wire coupler (3).
- Remove the starter relay with battery cover.

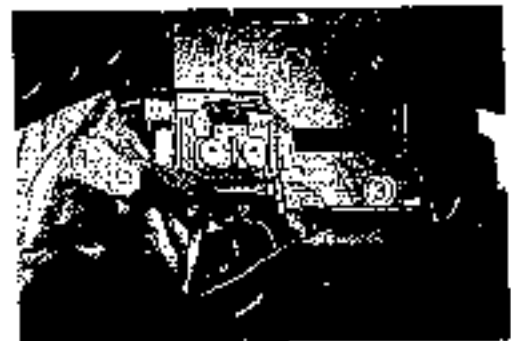

Apply 12 V to (A) and (B) lead wires and check for continuity between the positive and negative terminals using the multi circuit tester. If the starter relay clicks and continuity is found, the relay is ok.

TEST 09900-25008: Multi circuit tester set

TEST Tester knob indication: Continuity test (+)

CAUTION

Do not apply a battery voltage to the starter relay for more than five seconds, since the relay coil may over-heat and damaged.

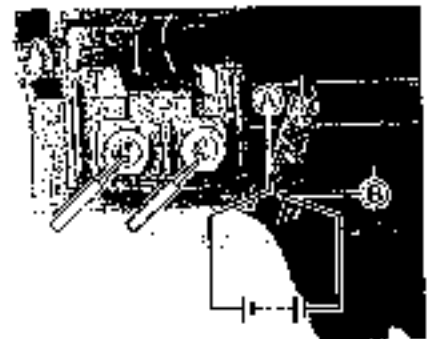

Measure the relay coil resistance between the terminals using the multi circuit tester. If the resistance is not within the specified value, replace the starter relay with a new one.

TEST 09900-25008: Multi circuit tester set

DATA Starter relay resistance: 3 – 6 Ω

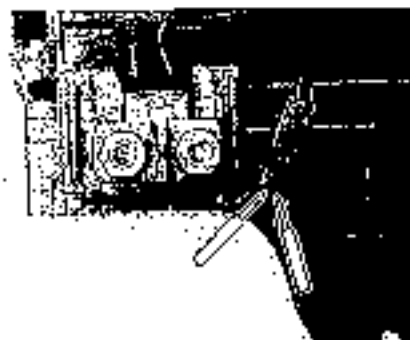

SIDE-STAND/IGNITION INTERLOCK SYSTEM PARTS INSPECTION

Check the interlock system for proper operation. If the interlock system does not operate properly, check each component for damage or abnormalities. If any abnormality is found, replace the component with a new one.

SIDE-STAND SWITCH

- Remove the maintenance lid. (C/F 9-13)
- Remove the left leg shield cover. (C/F 9-12)
- Disconnect the side-stand switch coupler and measure the voltage between Green and Black/White lead wires.

TEST 09900-25008: Multi circuit tester set

TEST Tester knob indication: Diode test (→←)

	Green (⊕) Probe	Black/White (⊖) Probe
ON (Side-stand up)	0.4 – 0.6 V	
OFF (Side-stand down)	More than 1.4 V (tester's battery voltage)	

NOTE:

If the tester reads under 1.4 V when the tester probes are not connected, replace its battery.

SIDE-STAND RELAY

- Remove the leg shield. (C/F 9-10)
- Remove the side-stand relay. (C/F 10-4)

NOTE:

Wire color of the side-stand relay lead wire are G, OW, B/W and Y/B.



First check the insulation between (A) and (B) terminals with the tester. Then apply 12 V to terminals as shown and check the continuity between (A) and (B). If there is no continuity, replace the side-stand relay with a new one.

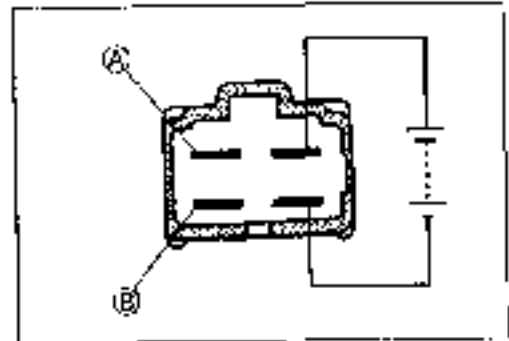

STARTER RELAY DIODE INSPECTION

- Remove left frame cover. (C279-16)
- Remove the diode. . .



Measure the voltage between the terminals using the multi circuit tester.

Unit: V

Probe of tester to:	⊕ Probe of tester to:	
	(A)	(B)
⊖	*	0.3 - 0.6

* More than 1.4 V (tester's battery voltage)

 09900-25008: Multi circuit tester set

 Tester knob indication: Diode test (←→)

NOTE:

If the tester reads under 1.4 V when the tester probes are not connected, replace the battery of multi circuit tester.

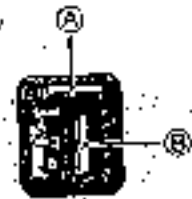

IGNITION SYSTEM

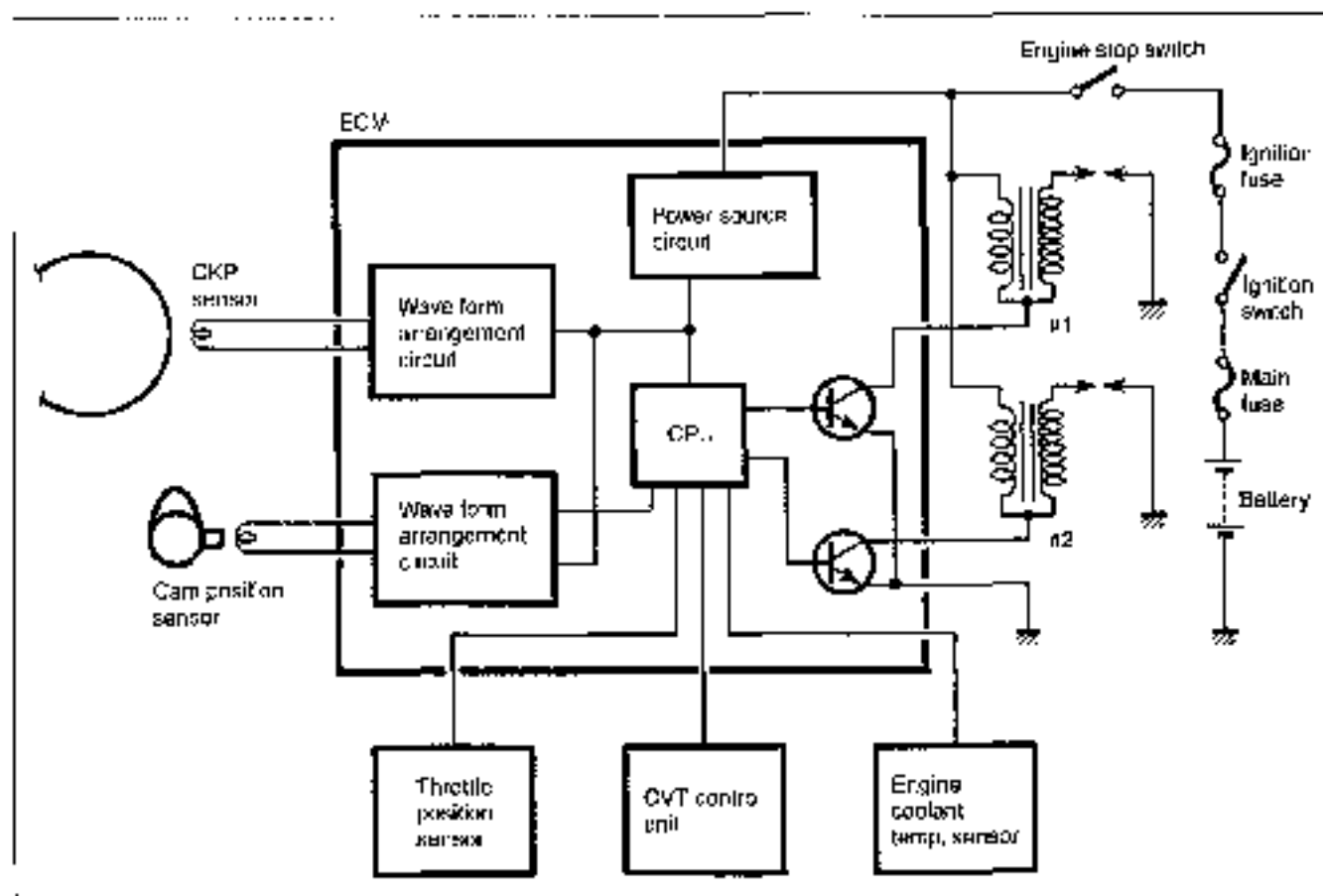
**NOTE:**

The ignition cut-off circuit is incorporated in this ECM to prevent over-running of engine. If engine rpm reaches 8 000 r/min., this circuit cuts off ignition primary current for all spark plugs.

CAUTION

Under no load, the engine can run over 8 000 r/min, even if the ignition cut-off circuit is effective, and it may cause engine damage. Do not run the engine without load over 8 000 r/min at anytime.

TROUBLESHOOTING

No spark or poor spark

Check the ignition system couplers for poor connections.

Correct

Continued on next page

Make sure the engine stop switch is in the "RUN" position and side-stand is in up-right position. Grasp the front or rear brake lever. Make sure the fuse is not blown and the battery is fully charged before diagnosing.

Loose

• Improper coupler connection

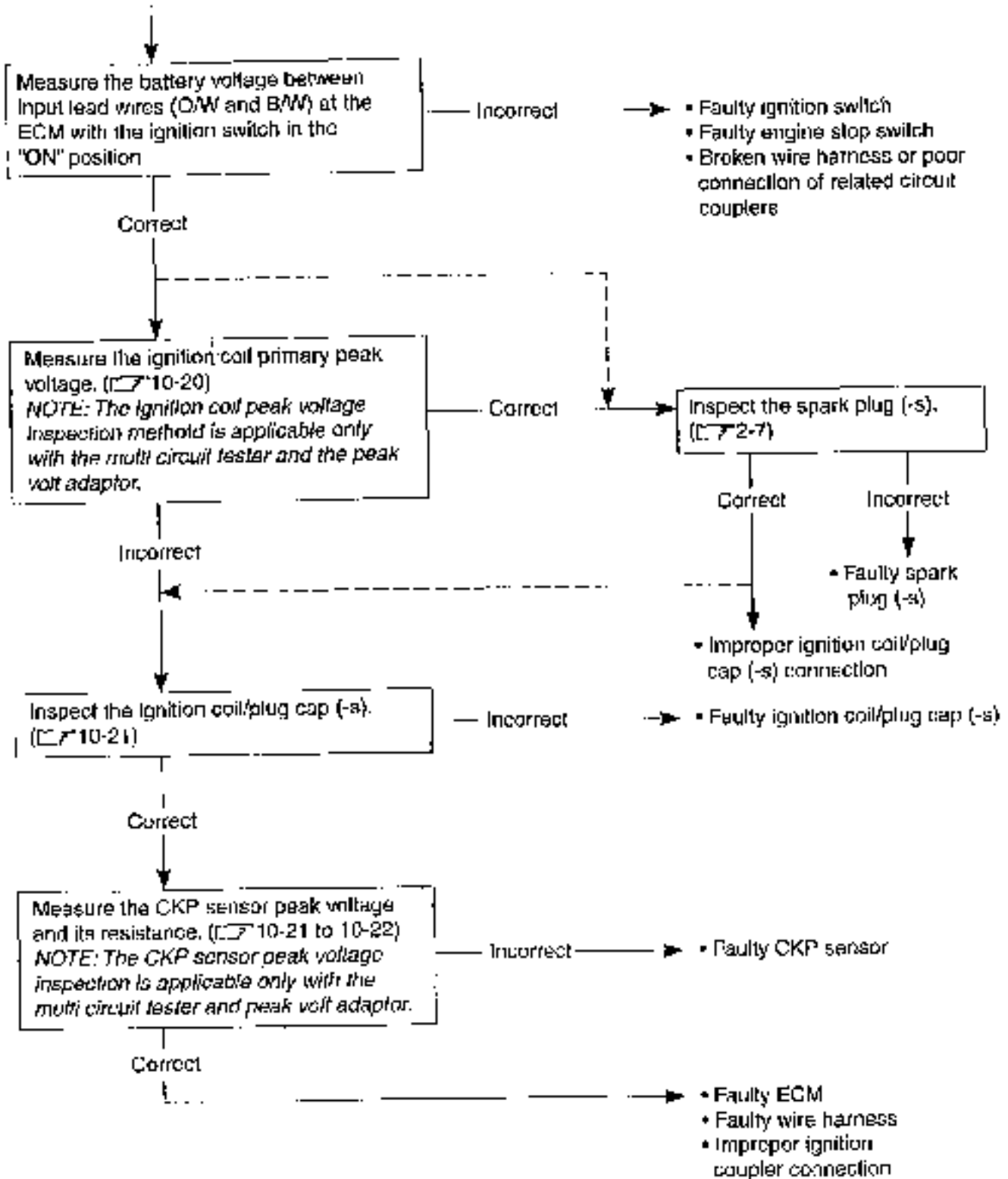

INSPECTION

IGNITION COIL PRIMARY PEAK VOLTAGE

- Remove the lower leg shield. (REF 9-10)
- Remove the radiator mounting bolt.
- Disconnect the two ignition coil/plug caps.
- Connect the new spark plugs to the each ignition coil/plug cap and ground them on the cylinder head.

NOTE:

Make sure that the each ignition coil/plug cap and spark plug are connected properly.

Measure the ignition coil primary peak voltage using the multi circuit tester in the following procedure.

- Connect the multi circuit tester with the peak volt adaptor as follows.

No.1 ignition coil/plug cap: (+) Probe: White/Blue lead wire connector
(-) Probe: Ground

No.2 ignition coil/plug cap: (+) Probe: Black/Yellow lead wire connector
(-) Probe: Ground

NOTE:

Do not disconnect the ignition coil/plug cap lead wire couplers.

 09900-25009: Multi circuit tester set

CAUTION:

Before using the multi circuit tester and peak volt adaptor, be sure to refer to the appropriate instruction manual.

- Set the side-stand upright position, and then turn the ignition switch to the "ON" position.
- Pull the front or rear brake lever.
- Press the starter button and allow the engine to crank for a few seconds, and then measure the ignition coil primary peak voltage.
- Repeat the above procedure a few times and measure the highest ignition coil primary peak voltage.

 Tester knob indication: Voltage (V)

DATA Ignition coil primary peak voltage: More than 80 V

WARNING

While testing, do not touch the tester probes and spark plugs to prevent receiving an electric shock.

If the peak voltage is lower than the specified values, inspect the ignition coil/plug cap. (REF 10-21)

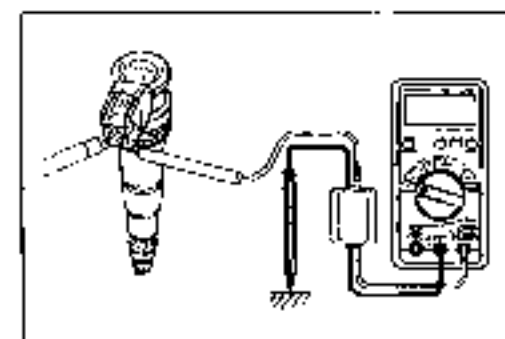
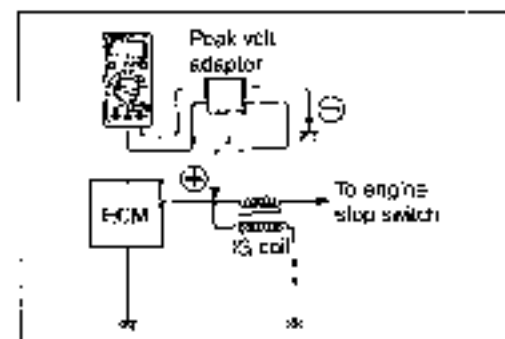
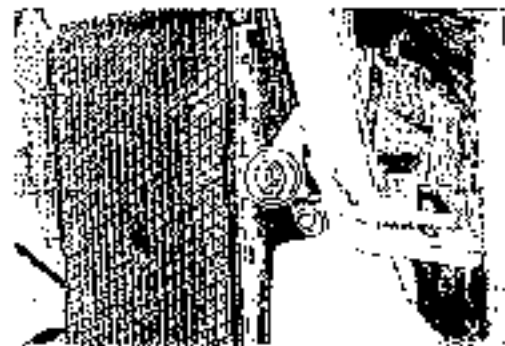

IGNITION COIL/PLUG CAP RESISTANCE

- Remove the radiator mounting bolt. (☞ 10-20)
- Remove the ignition coil/plug cap and disconnect its coupler. Measure the ignition coil/plug cap resistance in both the primary and secondary windings. If the resistance is not within the standard range, replace the ignition coil/plug cap with a new one.

 09900-25008: Multi circuit tester set

 Tester knob indication: Resistance (Ω)

DATA Ignition coil/plug cap resistance

Primary : 0.8 – 2.5 Ω (Terminal – Terminal)

Secondary: 8 – 18 k Ω (Plug cap – Terminal)

- Install the Ignition coil/plug cap

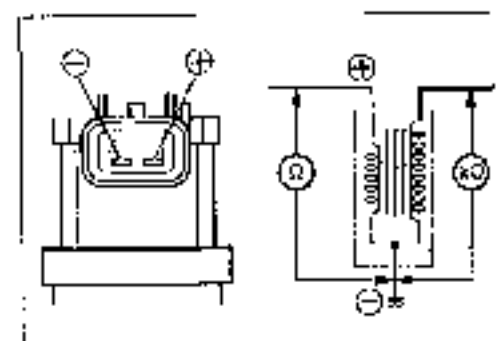
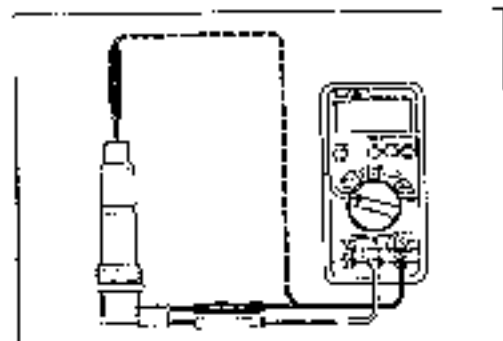
**CKP SENSOR PEAK VOLTAGE**

- Remove the front panel. (☞ 9-8)
- Disconnect the wire harness coupler (1) at the ECM.

Measure the CKP sensor peak voltage in the following procedure.

- Connect the multi circuit tester with the peak volt adaptor as follows

① Probe: White lead wire

② Probe: White/Green lead wire

 09900-25008: Multi circuit tester set

CAUTION

Before using the multi circuit tester and peak volt adaptor, be sure to refer to the appropriate instruction manual.



- Turn the ignition switch to the "ON" position.
- Pull the front or rear brake.
- Press the starter button and allow the engine to crank for a few seconds, and then measure the CKP sensor peak voltage.
- Repeat the above procedure a few times and measure the highest peak voltage.

 **Tester knob indication: Voltage (V)**

DATA CKP sensor peak voltage: More than 2.0 V

If the peak voltage is lower than the specified values, check the peak voltage at the CKP sensor lead wire coupler.

- Remove the maintenance lid. (E.S.D-13)
- Disconnect the CKP sensor lead wire coupler and connect the multi circuit tester with the peak volt adaptor.

- (+) Probe: Blue lead wire
- (-) Probe: Green lead wire

Measure the CKP sensor peak voltage at the CKP sensor lead wire coupler, in the same manner as on the ECM coupler.

 **Tester knob indication: Voltage (V)**

DATA CKP sensor peak voltage: More than 2.0 V

If the peak voltage on the CKP sensor lead wire coupler is ok but on the ECM coupler is out of specification, the wire harness must be replaced. If both peak voltages are out of specification, the generator must be replaced and re-checked.

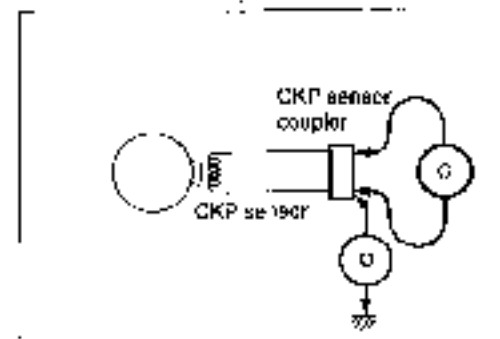
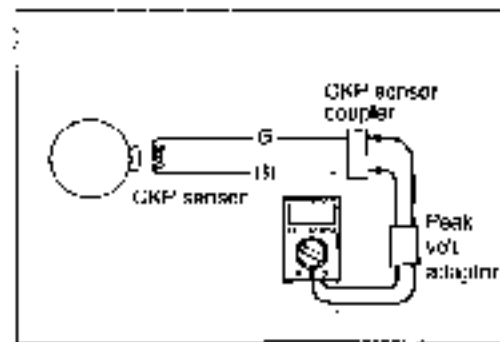
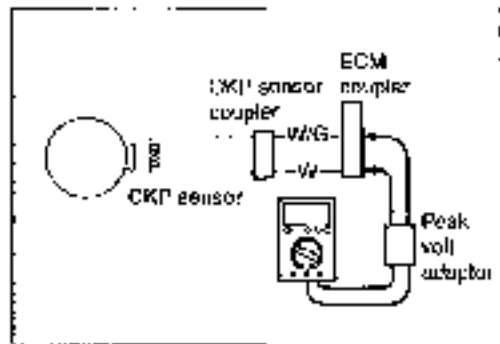

CKP SENSOR RESISTANCE

Measure the resistance between the lead wires and ground. If the resistance is not specified value, the CKP sensor must be replaced.

 **09900-25006: Multi circuit tester set**

 **Tester knob indication: Resistance (Ω)**

DATA CKP sensor resistance: 150 – 300 Ω (Green – Blue)
: ∞ Ω (Green – Ground)

- Connect the CKP sensor coupler and install the maintenance lid.

COMBINATION METER PARTS NAMES

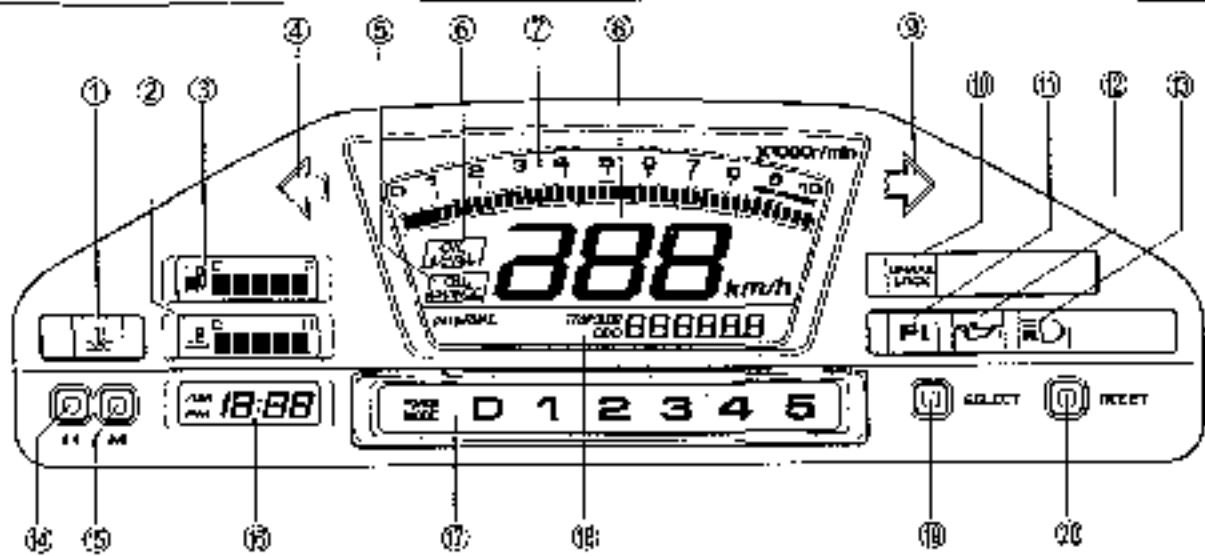

- ① Engine coolant lamp indicator light
- ② Engine coolant temp. meter
- ③ Fuel meter
- ④ Turn signal indicator light (L)
- ⑤ Engine oil charge indicator
- ⑥ Engine oil level indicator
- ⑦ Tachometer
- ⑧ Speedometer
- ⑨ Turn signal indicator light (R)
- ⑩ Brake lock indicator light

- ⑪ FI indicator light
- ⑫ Engine oil pressure indicator light
- ⑬ High beam indicator light
- ⑭ Clock hour adjust button
- ⑮ Clock minute adjust button
- ⑯ Clock
- ⑰ Riding mode indicator light
- ⑱ Odometer/tripmeter (A, B)
- ⑲ Select button
- ⑳ Reset button

REMOVAL AND DISASSEMBLY

- Remove the combination meter. (9-22)
- Disassemble the combination meter, as shown.

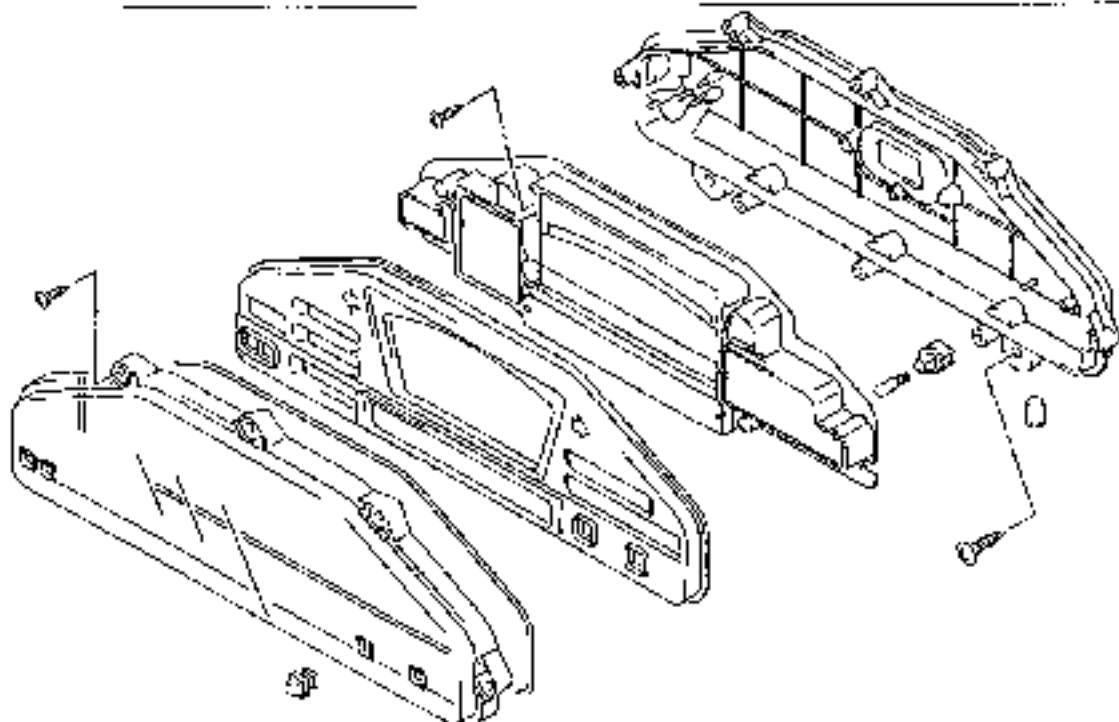

OPERATING PROCEDURE

INITIAL DISPLAY

When the ignition switch is set to ON, all LCD (Liquid Crystal Display) and engine coolant temp. Indicator, FI indicator and shift indicator lights light up for two seconds.

The tachometer light up for 0.5 second and then it operates 0 ↔ 10 000 r/min two times.

NOTE

If the power supply is cut (e.g., when the battery is replaced); Since the clock resets to "AM1:00", it will need to be readjusted.

CHANGE THE DISPLAY MODE

With each press of the SELECT button, the display changes between odometer, tripmeter A and tripmeter B as shown.

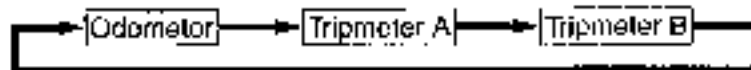

⚠ WARNING

To avoid riding with only one hand, do not operate the button while riding.

ODOMETER

Displays the total distance travelled.

TRIPMETER

Displays the distance travelled since the tripmeter was last reset.

NOTE

The tripmeters A and B can be used independently.

Hold down the RESET button over two seconds to reset the tripmeter.

CLOCK

Displays the time (hour and minutes) on a 12-hour clock.

Setting the time (ignition switch is "ON" position)

Press the "H" button to adjust the hour display.

Press the "M" button to adjust the minute display.

OIL CHANGE INDICATOR

The oil change indicator warns the driver of engine oil replacement timing. The indicator comes on at initial 1 000 km (600 miles) and the preset intervals thereafter. The preset interval can be varied in the range between 500 km (300 miles) to 6 000 km (3 600 miles) with a step of 500 km (300 miles). Reset the indicator after changing engine oil to turn off the display.

To reset the oil change indicator:

1. Turn off the ignition switch.
2. Hold down the "SELECT" and "RESET" buttons together and turn the ignition switch to the ON position. Continue pushing on the "SELECT" and "RESET" buttons for two seconds.
3. Oil change counter will be reset to initial and the indicator blinks for three seconds.

To vary the preset interval of oil change indicator:

1. Push the SELECT and RESET buttons together for two seconds until INTERVAL display comes on.
2. Push the SELECT button to decrease the interval from the maximum of 6 000 km (3 600 miles) to the desired interval with a step of 500 km (300 miles). The minimum possible interval is 500 km (300 miles).
3. Push the RESEST button to increase the interval from the minimum of 500 km (300 miles) to the desired interval with a step of 500 km (300 miles). The maximum possible interval is 6 000 km (3 600 miles).
4. Push the SELECT and RESET buttons together for more than two seconds.

NOTE:

- * The preset interval can be adjusted after the odometer reading has exceeded 1 000 km (600 miles)
- * Reset the indicator after engine oil replacement has been performed.

Example of oil change indicator setting

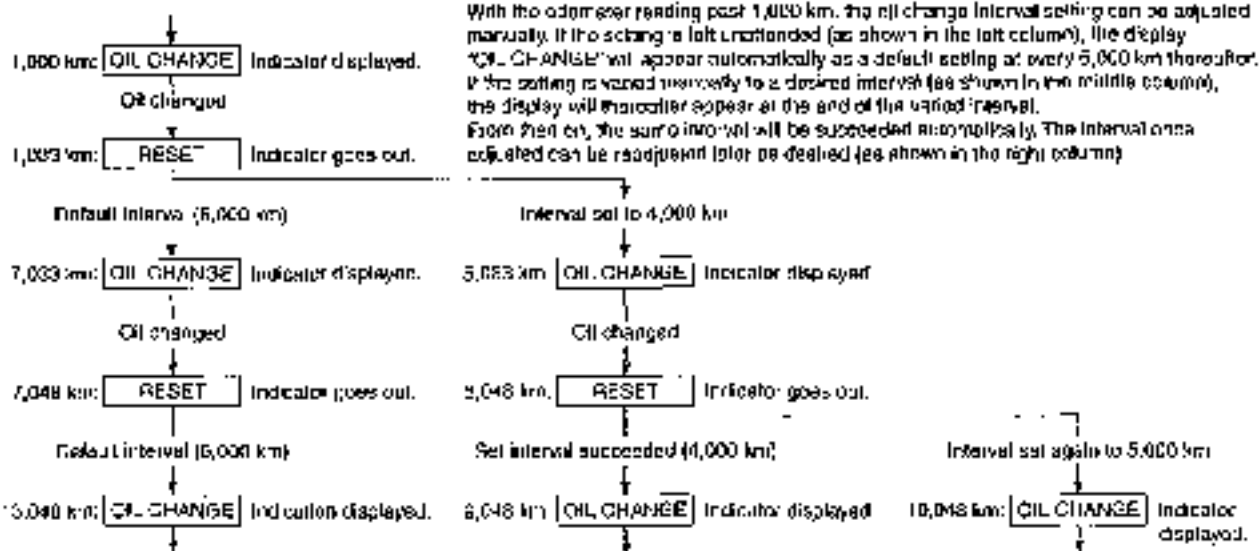

INSPECTION

ENGINE COOLANT TEMPERATURE METER AND INDICATOR LIGHT

- Disconnect the engine coolant temperature sensor coupler.

CAUTION

When connecting and disconnecting the engine coolant temp. sensor lead wire coupler, make sure to turn OFF the ignition switch, or electronic parts may get damaged.

- Connect the variable resistor (A) between the terminals.
- Turn the ignition switch "ON".
- Check the display of engine coolant temperature meter as shown below. If any abnormality is found, replace the combination meter with a new one.

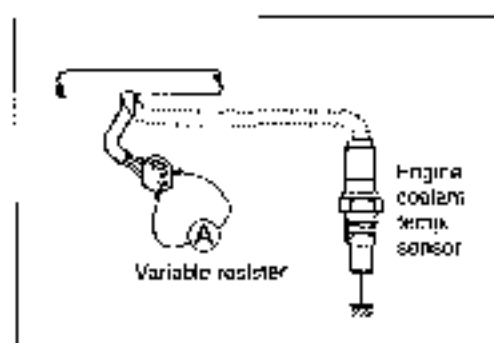

Engine coolant temperature sensor. (Fig. 8-13)

Engine coolant temperature	Under 39 °C	40 - 59 °C	60 - 99 °C	100 - 111 °C
Resistance	More than 1.148 kΩ	1.148 - 0.587 kΩ	0.587 - 0.188 kΩ	0.188 - 0.140 kΩ
Engine coolant temperature meter				
Engine coolant temperature indicator light	OFF	OFF	OFF	OFF





Engine coolant temperature	112 - 119 °C	Over 120 °C
Resistance	0.140 - 0.116 kΩ	Less than 0.116 kΩ
Engine coolant temperature meter		
Engine coolant temperature indicator light	OFF	

FUEL METER

- Remove the trunk box. (C.F. 9-16)
- Connect each resistor between the Red/Black and Black/White lead wires at the wire harness.
- Turn the ignition switch "ON" position and wait for approx. 13 seconds.

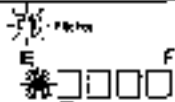
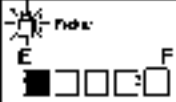
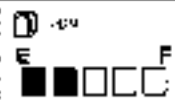
Check the display of fuel meter as shown below. If any abnormality is found, replace the combination meter with a new one.



Resistance	More than 112 Ω	96 - 112 Ω	82 - 96 Ω	71 - 82 Ω	51 - 62 Ω	Less than 50 Ω
Fuel level meter						

FUEL GAUGE

- Remove the fuel pump. (C.F. 7-7)

Measure the resistance at each fuel level gauge float position. If the resistance is incorrect, replace the fuel level gauge with a new one.

Float position	Resistance
Ⓐ "F" (Full)	Approx. 13 Ω
Ⓑ "E" (Empty)	Approx. 130 Ω

 08900-25008: Multi circuit tester set

 Tester knob indication: Resistance (Ω)

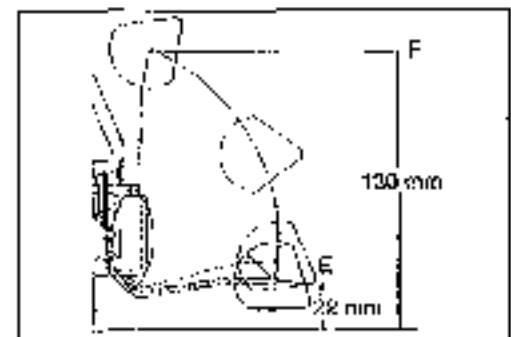

- Remove the fuel gauge (1) from the fuel pump.
- Install the fuel gauge
- Install the fuel pump. (CAF-11)

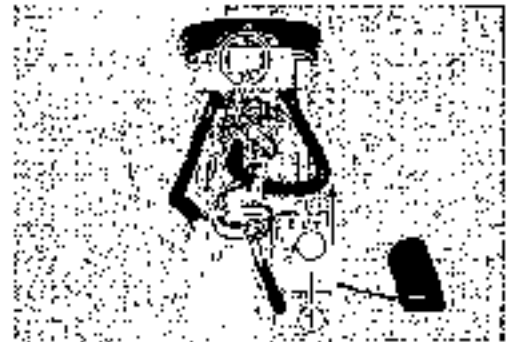

FUEL PUMP RELAY

- Remove the fuel pump relay. (CAF-10-4)
Same as side-stand relay (CAF-10-17)

OIL PRESSURE INDICATOR

NOTE:

Before inspecting the oil pressure switch, check the engine oil level. (CAF)

- Remove the leg side cover. (CAF-9-12)
- Disconnect the oil pressure switch lead wire from the oil pressure switch.
- Turn the ignition switch "ON" position.



Check if the oil pressure indicator comes on, when grounding the lead wire. If the oil pressure indicator does not come on, check the circuit connection or replace the bulb.

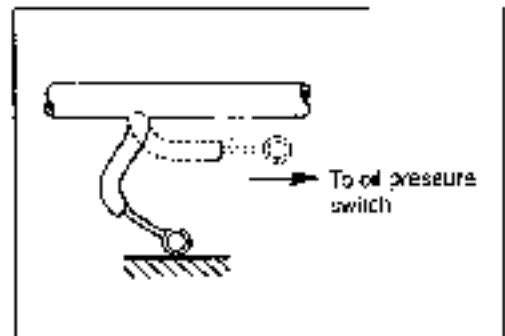

ENGINE OIL LEVEL INDICATOR

- Remove the maintenance lid. (C/P 9-13)
- Disconnect the oil level switch lead wire ①.
- Turn the ignition switch to the ON position.

Check if the oil level indicator comes on. If the oil level indicator does not come on, check the combination meter coupler or replace the combination meter.

**ENGINE OIL LEVEL SWITCH**

- Remove the engine oil level switch. (C/P 3-12)

Check the continuity between the lead wire and switch body. The relation between the position of the oil level gauge float in the oil level gauge and the continuity as shown below.

Switch position	Continuity
Ⓐ	ON
Ⓑ	OFF

- Install the oil level switch. (C/P 3-74)

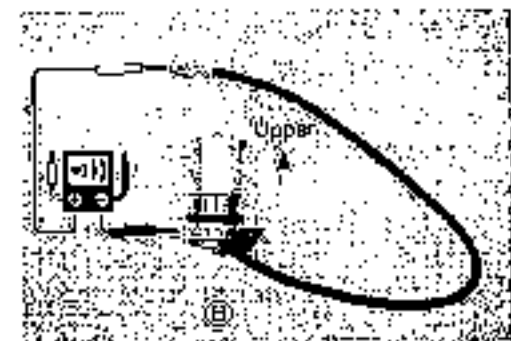
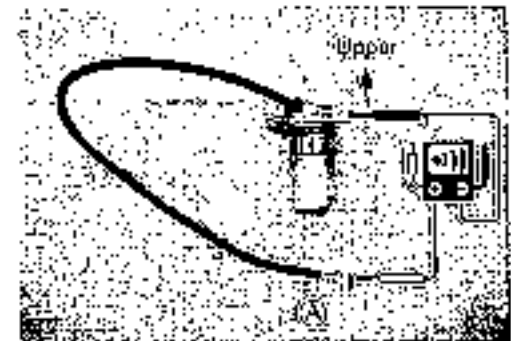
**SPEEDOMETER**

If the speedometer, odometer or trip meter does not function properly, inspect the speedometer sensor and connection of coupler. If the speedometer sensor and connection are all right, replace the meter with a new one.

SPEEDOMETER SENSOR

- Remove the final gear case cover. (☞ 2-15)
- Remove the left frame cover (☞ 9-16)
- Disconnect speedometer sensor coupler ①.
- Remove the speedometer sensor ② by removing its mounting bolt and lead wire set bolts.



Connect 12 V battery, 10 kΩ resistor and the multi circuit tester as shown in the right illustration.

O/R: Orange with Red tracer

B/W: Black with White tracer

W: White

 **09900-25008: Multi circuit tester set**

 **Tester knob Indication: Voltage (V)**

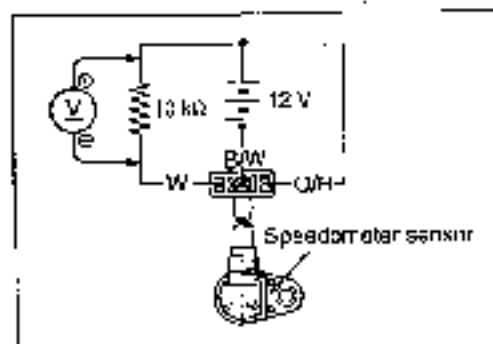

Under above condition, if a suitable screwdriver touching the pick-up surface of the speedometer sensor is moved, the tester reading voltage changes (0 V → 12 V or 12 V → 0 V). If the tester reading voltage does not change, replace the speedometer sensor with a new one.

NOTE:

The highest voltage reading in this test will be the same as that of battery voltage (12 V).

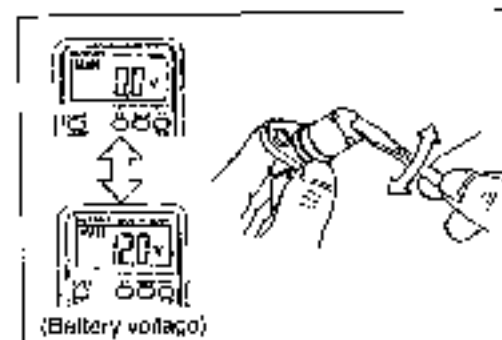

- Apply SUZUKI SUPER GREASE "A" to the speed sensor O-ring before installing it.

 **99000-25030: SUZUKI SUPER GREASE "A" (USA)**

99000-25010: SUZUKI SUPER GREASE "A" (Others)



LAMP HEADLIGHT

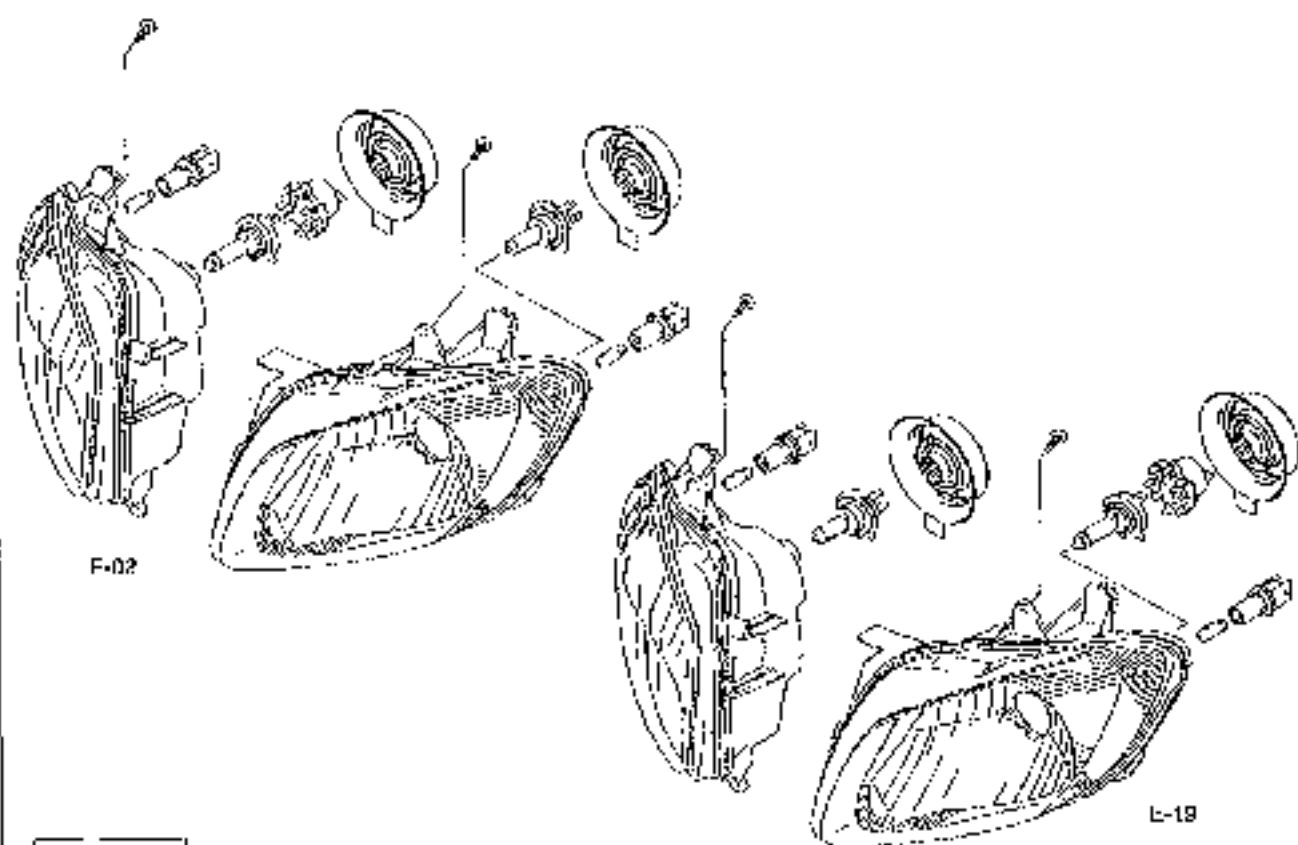

CAUTION

If you touch the bulb with your bare hands, clean the bulb with a cloth moistened with alcohol or soapy water to prevent premature bulb failure.

HEADLIGHT BULB REPLACEMENT

- Disconnect the lead wire couplers.
- Remove the headlight socket cover.
- Remove the headlight bulb (1) by releasing the bulb spring (2)
- Remove the position light (3)
- Install the bulbs.

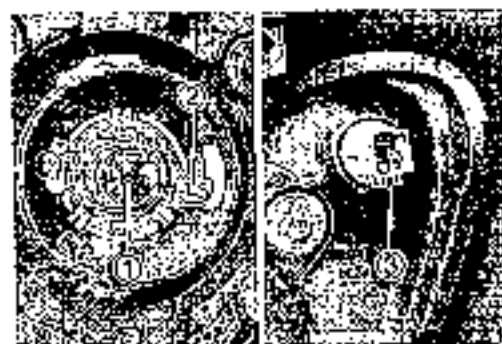

HEADLIGHT BEAM ADJUSTMENT

- Remove the front panel. (C-7 9-8)
- Adjust the headlight beam, both vertical and horizontal.
- Ⓐ Vertical adjuster (using a screw driver Ⓚ)
- Ⓑ Horizontal adjuster (using a screw driver Ⓚ)



BRAKE LIGHT/ TAILLIGHT, TURN SIGNAL LIGHT AND LICENSE LIGHT

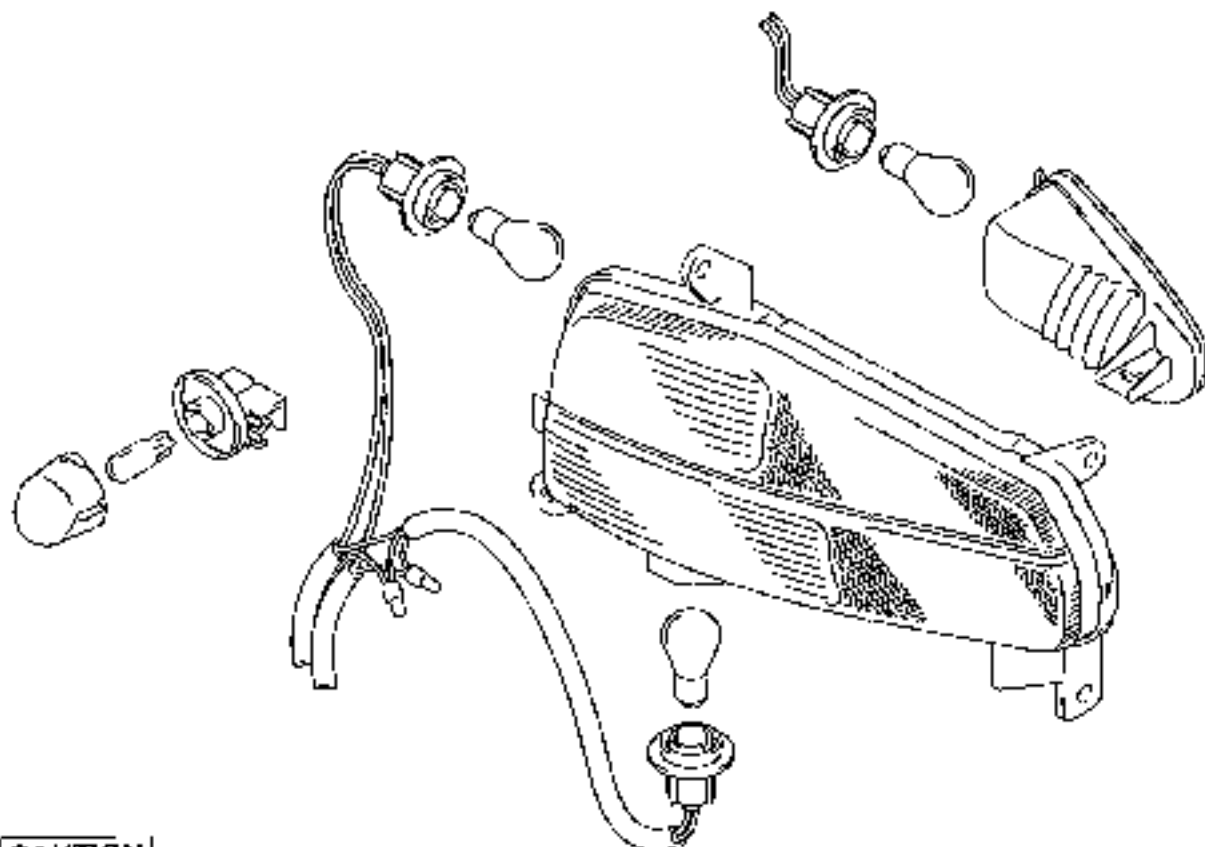

CAUTION

If you touch the bulb with your bare hands, clean the bulb with a cloth moistened with alcohol or soapy water to prevent premature bulb failure.

BULB REPLACEMENT

Front turn signal light

- Remove the cap ① and screw ②.
- Insert the suitable screwdriver into the screw hole.
- Remove the front turn signal light as shown.

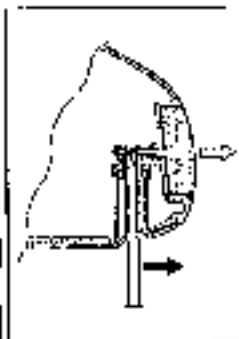

- Remove the socket ③.
- Remove the bulb ④.
- Install the turn signal light in the reverse order of removal.



Rear turn signal light

- Remove the center frame cover. (C-7-9-15)
- Remove the socket (1).
- Remove the bulb (2).
- Install the turn signal light in the reverse order of removal.

**Brake light/taillight**

- Remove the center frame cover (C-7-9-15)
- Remove the socket holder plate (1) and socket (2).
- Remove the bulb (3).
- Install the brake light/taillight in the reverse order of removal.

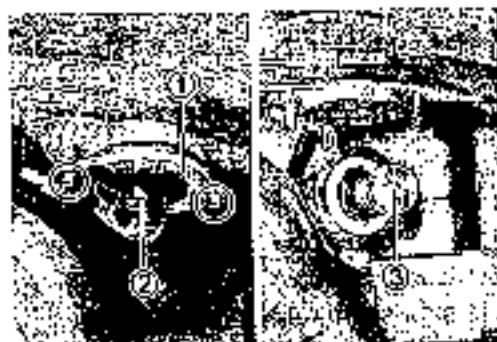
**License light**

- Remove the lower frame cover. (C-7-9-15)
- Remove the lens (1).
- Remove the bulb (2).
- Install the license light in the reverse order of removal.

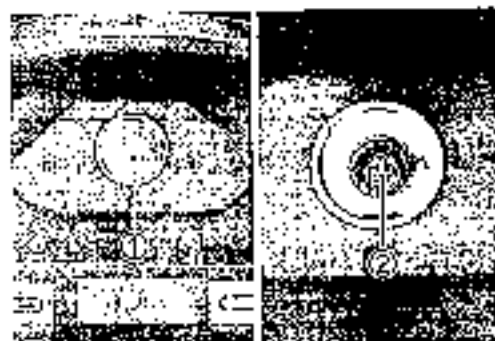

RELAYS

TURN SIGNAL RELAY

INSPECTION

Before removing the turn signal relay, check the operation of the turn signal light.

If the turn signal light does not illuminate, inspect the bulb, turn signal switch and circuit connection.

If the bulb, turn signal switch and circuit connection are OK, the turn signal relay may be faulty; therefore, replace the turn signal relay with a new one.

NOTE:

Make sure that the battery is fully charged.



COOLING FAN MOTOR RELAY

- Remove the cooling fan motor relay. (☞ 10-4)

First check the insulation between (A) and (B) terminals with the tester. Then apply 12 V to terminals as shown and check the continuity between (A) and (B). If there is no continuity, replace the side-stand relay with a new one.

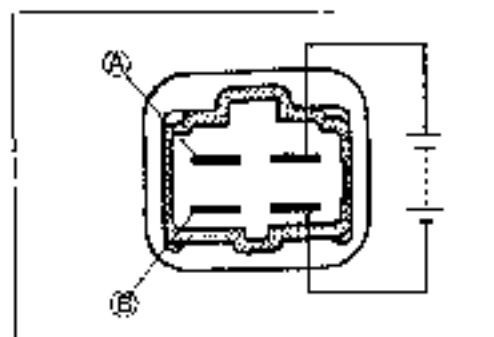

FUEL PUMP RELAY

☞ 10-28

SIDE-STAND RELAY

☞ 10-16, 16-17

STARTER RELAY

☞ 10-15

SWITCHES

IGNITION SWITCH REMOVAL

☞ 9-19

INSPECTION

Inspect each switch for continuity with a tester.
If any abnormality is found, replace the respective switch assemblies with new ones.

IGNITION SWITCH

For E-24

Color Position	R	O	O/B	B/W	O/G	Br
ON						
OFF						
LOCK						

For Others

Color Position	R	O	O/B	B/W	O/G	Br
ON						
OFF						
LOCK						
P						

LIGHTING SWITCH

For AN650L

Color Position	O/Bl	Gr	O/H	Y/W
OFF				
S				
ON				

DIMMER SWITCH

Color Position	W	Y	Y/W
HI			
LO			

PASSING LIGHT SWITCH

Except for E-03, 28 and 33

Color Position	Y	O/R
PUSH		

TURN SIGNAL SWITCH

Color Position	Lg	Lbl	B
L			
PUSH			
R			

HAZARD SWITCH

Except for E-03, 24, 28, 33 and AN650L

Color Position	B	Lbl	Lg
OFF			
ON			

ENGINE STOP SWITCH

Color Position	O/R	O/W
OFF (X)		
RUN (O)		

STARTER BUTTON

Color Position	B/Bl	Y/G
PUSH		

HORN BUTTON

Color Position	B/Bl	R/W
PUSH		

FRONT BRAKE SWITCH

Color Position	B/R	R/Bl
OFF		
ON		

REAR BRAKE SWITCH

Color Position	B/G	B/R
OFF		
ON		

BRAKE LOCK SWITCH

Color Position	Y	O/G
OFF		
ON		

CVT UP/DOWN SWITCH

Color Position	Y/G	Bl/W	G
UP			
FREE			
DOWN			

CVT POWER SWITCH

Color Position	Br/W	R/W
FREE	_____	_____
PUSH	○_____	_____○

CVT "D" ↔ "M" SWITCH

Color Position	Br/W	Bl/Y
FREE	_____	_____
PUSH	○_____	_____○

TRUNK LIGHT SWITCH

Color Position	R	B/W
OFF	_____	_____
ON	○_____	_____○
OFF	_____	_____

TRUNK LIGHT SEAT SWITCH

Color Position	B	B/W
PUSH	○_____	_____○

OIL LEVEL SWITCH

☞ 10-29

OIL PRESSURE SWITCH

Color Position	G/Y	Ground
ON (engine is stopped)	○_____	_____○
OFF (engine is running)	_____	_____

NOTE:

Before inspecting the oil pressure switch check if engine oil level is enough. (☞ 2-14)

COOLING FAN THERMO SWITCH

☞ 8-16

WIRE COLOR

B	: Black	LB	: Light blue	Y	: Yellow
Br	: Brown	Lg	: Light green	W	: White
G	: Green	O	: Orange		
Gr	: Gray	R	: Red		
GB	: Black with Blue tracer				
GB	: Black with Green tracer				
BW	: Black with White tracer				
B/R	: Black with Red tracer				
B/Y	: Black with Yellow tracer				
Br/W	: Brown with White tracer				
G/Y	: Green with Yellow tracer				
O/B	: Orange with Black tracer				
O/Bl	: Orange with Blue tracer				
O/G	: Orange with Green tracer				
O/R	: Orange with Red tracer				
O/W	: Orange with White tracer				
R/W	: Red with White tracer				
Y/G	: Yellow with Green tracer				
Y/W	: Yellow with White tracer				

BATTERY

SPECIFICATIONS

Type Designation	FTX14-BS
Capacity	12V, 43.2 kC (12 Ah)/10HR

- | | |
|----------------------------------|------------------|
| (a) Anodic plates | (g) Stopper |
| (b) Separator (fiberglass plate) | (h) Filler |
| (c) Cathode plates | (i) Terminal |
| (d) Upper cover breather | (j) Safety valve |

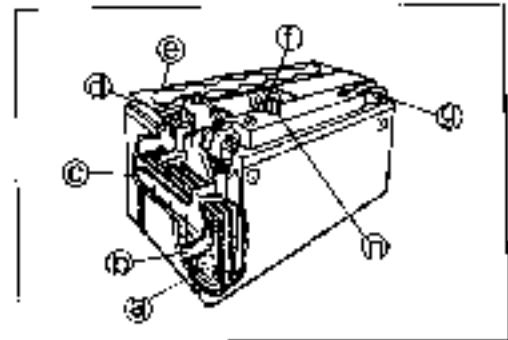

INITIAL CHARGING

FILLING ELECTROLYTE

- Remove the aluminum tape (1) which seals the battery filler holes (2).

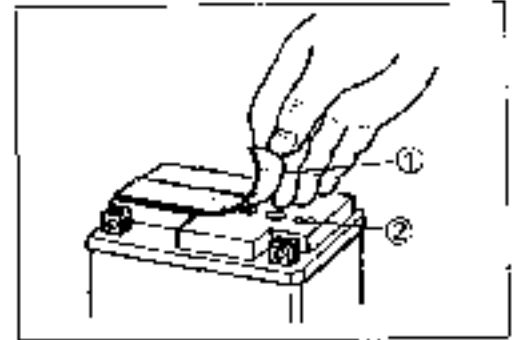

- Remove the caps (3) from the electrolyte container.

NOTE:

- Do not remove or pierce the sealed areas (4) of the electrolyte container.
- After completely filling the battery with electrolyte, use the caps (3) from the electrolyte container to seal the battery filler holes.

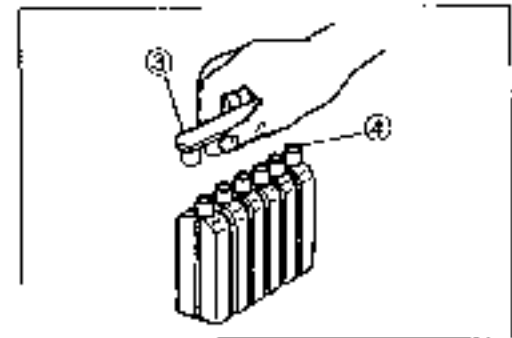

- Insert the nozzle of the electrolyte container (5) into the electrolyte filler holes of the battery. Hold the electrolyte container firmly so that it does not fall. Do not allow any of the electrolyte to spill.

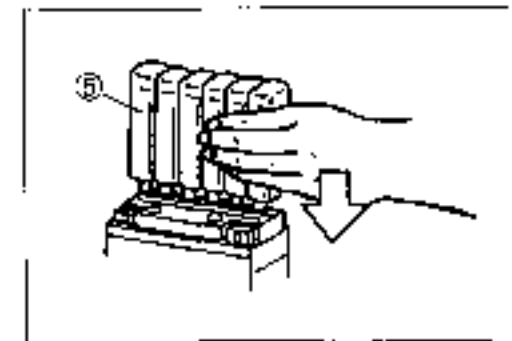

- Make sure the air bubbles (i) rise to the top of each electrolyte container and leave the electrolyte container in this position for more than 20 minutes.

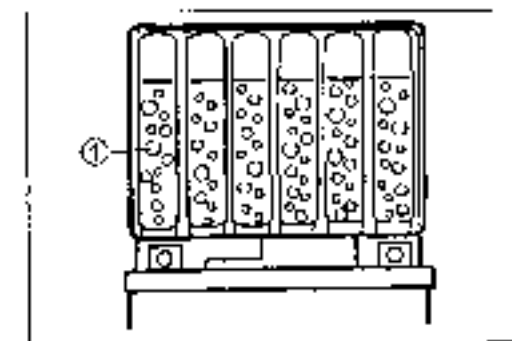

NOTE:

If air bubbles do not rise from any one of the filler ports, tap the bottom of the electrolyte container two or three times. Never remove the electrolyte container from the battery while there is still electrolyte in the container.

- After the electrolyte container is completely empty, remove it from the battery and wait about 20 minutes
- Insert the caps (2) firmly into the filler holes, so that the top of the caps do not protrude above the upper surface of the top cover of the battery.

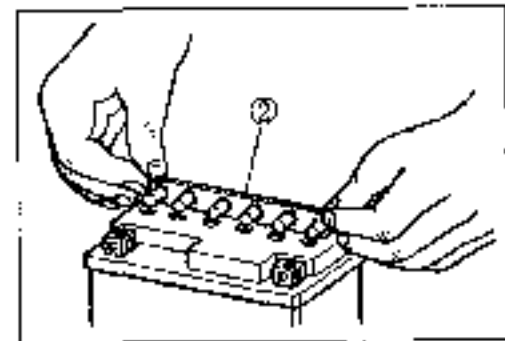
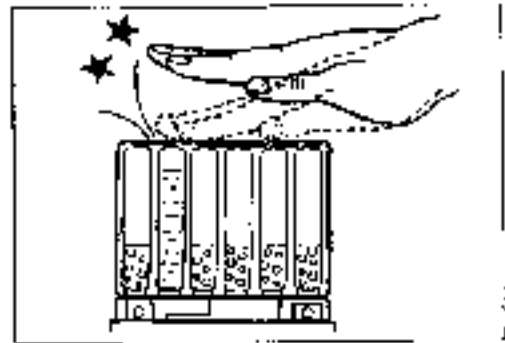
**CAUTION**

- Never use anything except the specified battery.
- Once install the caps to the battery; do not remove the caps.
- Do not tap the caps with a hammer when installing them.

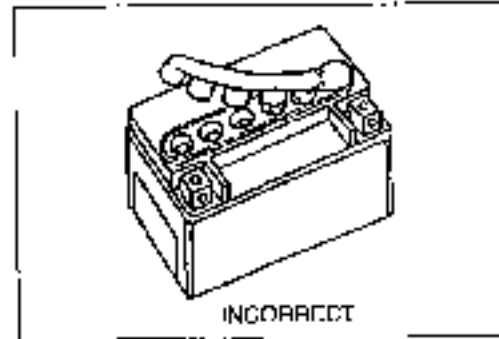
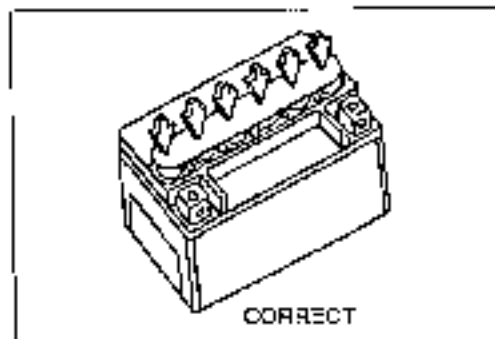

Measure the battery voltage using multi circuit tester. The tester should indicate more than 12.5 - 12.6 V (DC) as shown in the Fig. If the battery voltage is lower than the specification, charge the battery with a battery charger. (Refer to the recharging operation)

CAUTION

Do not remove the caps on the battery top while charging.

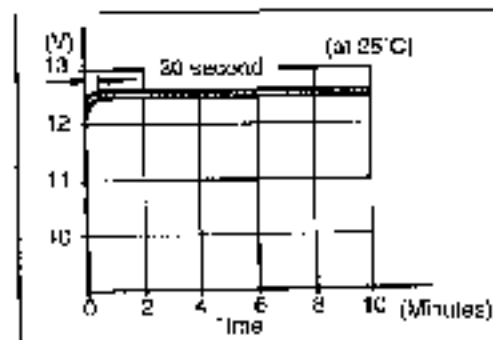
**NOTE:**

Initial charging for a new battery is recommended if two years have elapsed since the date of manufacture.

SERVICING

Visually inspect the surface of the battery container. If any signs of cracking or electrolyte leakage from the sides of the battery have occurred, replace the battery with a new one. If the battery terminals are found to be coated with rust or an acidic white powdery substance, clean the battery terminals with sandpaper.

RECHARGING OPERATION

Measure the battery voltage using the multi circuit tester. If the voltage reading is less than the 12 V (DC), recharge the battery with a battery charger.

CAUTION

When recharging the battery, remove the battery from the motorcycle.

NOTE:

While recharging, do not remove the caps on the top of the battery.

Recharging time: 1.4 A for 5 to 10 hours or 6 A for 1 hour.

CAUTION

Be careful not to permit the charging current to exceed 5 A at any time.

After recharging, wait at least 30 minutes and then measure the battery voltage using the multi circuit tester. If the battery voltage is less than 12.5 V, recharge the battery again. If the battery voltage is still less than 12.5 V after recharging, replace the battery with a new one.

When a battery is left unused for a long time, its voltage needs to be regularly measured. When the motorcycle is not used for more than one month (especially during the winter season), measure the battery voltage at least once a month.

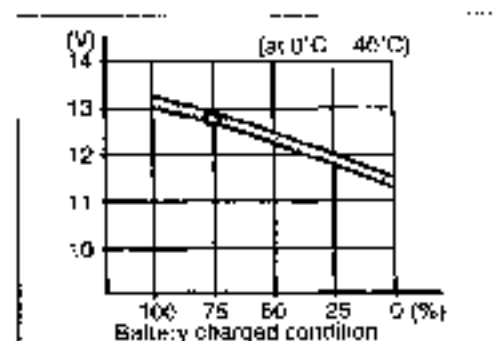
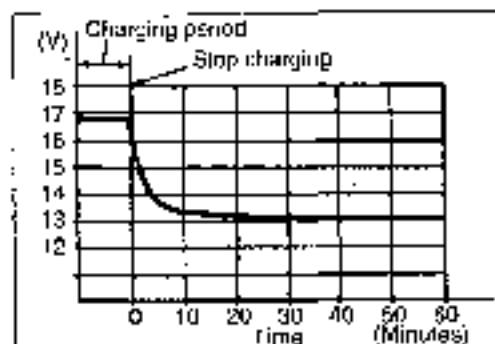

SERVICING INFORMATION

CONTENTS

TROUBLESHOOTING	11- 2
FI SYSTEM/ CVT SYSTEM MALFUNCTION CODE AND DEFECTIVE CONDITION	11- 2
ENGINE	11- 4
CVT	11- 9
RADIATOR (COOLING SYSTEM)	11- 9
CHASSIS	11-10
BRAKES	11-11
ELECTRICAL	11-12
BATTERY	11-13
WIRING HARNESS, CABLE AND HOSE ROUTING	11-14
WIRING HARNESS ROUTING	11-14
CABLE ROUTING	11-18
THROTTLE BODY INSTALLATION/HOSE ROUTING	11-20
FUEL TANK MOUNTING	11-21
FUEL TANK HOSE ROUTING	11-22
RADIATOR HOSE ROUTING	11-23
FRONT BRAKE HOSE ROUTING	11-24
REAR BRAKE HOSE ROUTING	11-25
SIDE-STAND SET-UP	11-26
CENTER STAND SET-UP	11-26
SPECIAL TOOLS	11-27
TIGHTENING TORQUE	11-31
ENGINE	11-31
CVT	11-32
CHASSIS	11-32
TIGHTENING TORQUE CHART	11-33
SERVICE DATA	11-34

TROUBLESHOOTING

FI SYSTEM/ CVT SYSTEM MALFUNCTION CODE AND DEFECTIVE CONDITION

MALFUNCTION CODE	DETECTED ITEM	DETECTED FAILURE CONDITION CHECK FOR
C00	NO FAULT	
C11	Camshaft position sensor	The signal does not reach ECM for more than 2 sec. after receiving the starter signal. The camshaft position sensor wiring and mechanical parts. (Camshaft position sensor, intake cam pin, wiring/coupler connection)
C12	Crankshaft position sensor	The signal does not reach ECM for more than 2 sec. after receiving the starter signal. The crankshaft position sensor wiring and mechanical parts. (Crankshaft position sensor, wiring/coupler connection)
C13	Intake air pressure sensor	The sensor should produce following voltage. (0.50 V \leq sensor voltage < 4.85 V) Without the above range, C13 is indicated. Intake air pressure sensor, wiring/coupler connection.
C14	Throttle position sensor	The sensor should produce following voltage. (0.20 V \leq sensor voltage < 4.80 V) Without the above range, C14 is indicated. Throttle position sensor, wiring/coupler connection.
C15	Engine coolant temperature sensor	The sensor voltage should be the following. (0.15 V \leq sensor voltage < 4.85 V) Without the above range, C15 is indicated. Engine coolant temperature sensor, wiring/coupler connection.
C16	Speed sensor	The speed sensor signal is not input for more than 3 sec. during vehicle deceleration. Speed sensor, wiring/coupler connection.
C21	Intake air temperature sensor	The sensor voltage should be the following. (0.15 V \leq sensor voltage < 4.85 V) Without the above range, C21 is indicated. Intake air temperature sensor, wiring/coupler connection.
C22	Atmospheric pressure sensor	The sensor voltage should be the following. (0.50 V \leq sensor voltage < 4.85 V) Without the above range, C22 is indicated. Atm. pressure sensor, wiring/coupler connection.
C23	Tip over sensor	The sensor voltage should be the following for more than 2 sec. after ignition switch turns ON. (0.20 V \leq sensor voltage < 4.80 V) Without the above value, C23 is indicated. Tip over sensor, wiring/coupler connection.
C24 or C25	Ignition signal	Crankshaft position sensor (pick-up coil) signal is produced but signal from ignition coil is interrupted continuously by 4 times or more. In this case, the code C24 or C25 is indicated. Ignition coil, wiring/coupler connection, power supply from the battery.

C32 or C33	Fuel injector	Crankshaft position sensor (pick-up coil) signal is produced but fuel injector signal is interrupted continuous by 4 times or more. In this case, the code C32 or C33 is indicated. Injector, wiring/coupler connection, power supply to the injector.
C40	Intake air control (IAC) valve	No IAC valve voltage is supplied after starting the engine. IAC valve, wiring/coupler connection.
C41	Fuel pump relay	No voltage is applied to fuel pump although fuel pump relay is turned ON, or voltage is applied to fuel pump although fuel pump relay is turned OFF. Fuel pump relay, connecting lead, power source to fuel pump relay.
C42	Ignition switch	Ignition switch signal is not input in the ECM. Ignition switch, lead wire/coupler.
C44	Heated oxygen sensor (HO2S) [E-02, 1B]	During O2 feedback control, O2 sensor generating voltage is as follows. (Sensor voltage < 0.45). The heater circuit disconnection is detected during engine operation, or no electrical power is supplied from battery. HO2S lead wire/coupler connection. Battery voltage supply to the HO2S.
C50	CVT serial communication	No signal is supplied from CVT control unit to ECM for more than 5 sec. after starting the engine. Wiring/coupler connection.
C51	CVT motor	The CVT motor operating voltage is not supplied from CVT control unit. CVT motor, wiring/coupler connection.
C52	CVT pulley position sensor	The sensor should produce following voltage. (0.06 ≤ sensor voltage ≤ 5.04) Without the above range, C52 is indicated. CVT pulley position sensor, wiring/coupler connection.
C53	CVT speed sensor	The CVT speed sensor signal is not input to CVT control unit for more than 3 sec. during vehicle running. Speed sensor, wiring/coupler connection.
C54	CVT secondary pulley revolution sensor	The CVT secondary pulley revolution signal is not input to CVT control unit at speed of 20 km or higher. CVT secondary pulley revolution sensor, wiring/coupler connection.
C55	CVT engine revolution signal	The CVT engine revolution signal is not input to CVT control unit from ECM at speed of 20 km or higher. Wiring/coupler connection.
C56	CVT throttle position signal	The CVT throttle position signal does not reach for more than 5 sec. from ECM to CVT control unit after ignition switch turns ON. Wiring/coupler connection.
C58	CVT reduction ratio disagreement	The CVT pulley position signal disagrees with actual revolution ratio for more than 4 sec. PFS, CVT belt, CVT primary pulley/secondary pulley.

ENGINE

Complaint	Symptom and possible causes	Remedy
<p>Engine will not start or is hard to start.</p>	<p>Compression too low</p> <ol style="list-style-type: none"> 1. Tappet clearance out of adjustment. 2. Worn valve guides or poor seating of valves. 3. Mismatched valves. 4. Excessively worn piston rings. 5. Worn-down cylinder bores. 6. Starter motor cranks too slowly. 7. Poor seating of spark plugs. <p>Plugs not sparking</p> <ol style="list-style-type: none"> 1. Fouled spark plugs. 2. Wet spark plugs. 3. Defective ignition coil or camshaft position sensor. 4. Open or short in high tension cords. 5. Defective crankshaft position sensor. 6. Defective ECM. 7. Open-circuited wiring connections. <p>No fuel reaching the intake manifold</p> <ol style="list-style-type: none"> 1. Clogged fuel filter or fuel hose. 2. Defective fuel pump. 3. Defective fuel pressure regulator. 4. Defective fuel injector. 5. Defective fuel pump relay. 6. Defective ECM. 7. Open-circuited wiring connections. <p>Incorrect fuel/air mixture</p> <ol style="list-style-type: none"> 1. Throttle position sensor out of adjustment. 2. Defective fuel pump. 3. Defective fuel pressure regulator. 4. Defective throttle position sensor. 5. Defective crankshaft position sensor. 6. Defective intake air pressure sensor. 7. Defective atmospheric pressure sensor. 8. Defective ECM. 9. Defective engine coolant temp. sensor. 10. Defective intake air temp. sensor. 	<p>Adjust. Repair or replace. Adjust. Replace. Replace. See electrical section. Retighten.</p> <p>Clear. Clean and dry. Replace. Replace. Replace. Replace. Repair or replace.</p> <p>Clean or replace. Replace. Replace. Replace. Replace. Replace. Check and repair.</p> <p>Adjust. Replace. Replace. Replace. Replace. Replace. Replace. Replace. Replace. Replace.</p>
<p>Engine idles poorly.</p>	<ol style="list-style-type: none"> 1. Tappet clearance out of adjustment. 2. Poor seating of valves. 3. Defective valve guides. 4. Worn down camshaft. 5. Too wide spark plug gaps. 6. Defective ignition coil. 7. Defective crankshaft position sensor. 8. Defective ECM. 9. Defective throttle position sensor. 10. Defective fuel pump. 11. Imbalanced throttle valve. 12. Damaged or cracked vacuum hose. 13. Defective IAC valve. 	<p>Adjust. Replace or repair. Replace. Replace. Adjust or replace. Replace. Replace. Replace. Replace. Replace. Adjust. Replace. Replace.</p>

Complaint	Symptom and possible causes	Remedy
Engine stalls often	Incorrect fuel/air mixture	Repair or replace
	1. Defective intake air pressure sensor or circuit.	Clean or replace.
	2. Clogged fuel filter.	Replace.
	3. Defective fuel pump.	Replace.
	4. Defective fuel pressure regulator.	Replace.
	5. Damaged or cracked vacuum hose.	Replace.
	6. Defective engine coolant temp. sensor.	Replace.
	7. Defective thermostat.	Replace.
	8. Defective intake air temp. sensor.	Replace.
	Fuel injector improperly operating	Replace.
	1. Defective fuel injector.	Repair or replace.
	2. No injection signal from ECM.	Repair or replace.
3. Open or short circuited wiring connection.	Replace or recharge.	
4. Defective battery or low battery voltage.		
Control circuit or sensor improperly operating	Replace	
1. Defective ECM.	Replace.	
2. Defective fuel pressure regulator.	Replace.	
3. Defective throttle position sensor.	Replace.	
4. Defective intake air temp. sensor.	Replace.	
5. Defective camshaft position sensor.	Replace.	
6. Defective crankshaft position sensor.	Replace.	
7. Defective engine coolant temp. sensor.	Replace.	
8. Defective fuel pump relay.	Replace.	
Engine parts improperly operating	Clean.	
1. Fouled spark plugs.	Replace.	
2. Defective crankshaft position sensor or ECM.	Clean.	
3. Clogged fuel hose.	Adjust.	
4. Tappet clearance out of adjustment.		

Complaint	Symptom and possible causes	Remedy
Noisy engine.	Excessive valve chatter 1. Too large tappet clearance. 2. Weakened or broken valve springs. 3. Worn tappet or cam surface. 4. Worn and burnt camshaft journal.	Adjust. Replace. Replace. Replace.
	Noise seems to come from piston 1. Worn down pistons or cylinders. 2. Combustion chambers fouled with carbon. 3. Worn piston pins or piston pin bore. 4. Worn piston rings or ring grooves.	Replace. Clean. Replace. Replace.
	Noise seems to come from timing chain 1. Stretched chain. 2. Worn sprockets. 3. Tension adjuster not working.	Replace. Replace. Repair or replace.
	Noise seems to come from clutch 1. Worn splines of countershaft or hub. 2. Worn teeth of clutch plates. 3. Distorted clutch plates, driven and drive. 4. Worn clutch release bearing. 5. Weakened clutch dampers.	Replace. Replace. Replace. Replace. Replace the primary driver gear.
	Noise seems to come from crankshaft 1. Rattling bearings due to wear. 2. Worn and burnt big-end bearings. 3. Worn and burnt journal bearings. 4. Too large thrust clearance.	Replace. Replace. Replace. Replace thrust bearing.
	Noise seems to come from transmission 1. Worn or rubbing gears. 2. Worn splines. 3. Worn or rubbing primary gears. 4. Worn bearings.	Replace. Replace. Replace. Replace.
	Noise seems to come from water pump 1. Too much play on pump shaft bearing. 2. Worn or damaged impeller shaft. 3. Worn or damaged mechanical seal. 4. Contact between pump case and impeller.	Replace. Replace. Replace. Replace.
Engine runs poorly in high speed range.	Defective engine internal/electrical parts 1. Weakened valve springs. 2. Worn camshafts. 3. Valve timing out of adjustment. 4. Too narrow spark plug gaps. 5. Ignition not advanced sufficiently due to poorly working timing advance circuit. 6. Defective ignition coil. 7. Defective crankshaft position sensor. 8. Defective ECM. 9. Clogged air cleaner element. 10. Clogged fuel hose, resulting in inadequate fuel supply to injector. 11. Defective fuel pump. 12. Defective throttle position sensor.	Replace. Replace. Adjust. Adjust. Replace ECM. Replace. Replace. Replace. Clean. Clean and prime. Replace. Replace.

Complaint	Symptom and possible causes	Remedy
Engine runs poorly in high speed range.	Defective air flow system 1. Clogged air cleaner element. 2. Defective throttle valve. 3. Defective IAC valve. 4. Sucking air from throttle body joint. 5. Imbalanced throttle valve synchronization. Defective control circuit or sensor 1. Low fuel pressure. 2. Defective throttle position sensor. 3. Defective intake air temp. sensor. 4. Defective camshaft position sensor. 5. Defective crankshaft position sensor. 6. Defective gear position switch. 7. Defective intake air pressure sensor. 8. Defective atmospheric pressure sensor. 9. Defective ECM. 10. Throttle position sensor out of adjustment. 11. Defective fuel tank pressure control valve.	Clean or replace. Adjust or replace. Replace. Repair or replace. Adjust. Repair or replace. Replace. Repair. Replace. Replace. Replace. Replace. Replace. Adjust. Replace.
Engine lacks power.	Defective engine internal/electrical parts 1. Loss of tappet clearance. 2. Weakened valve springs. 3. Valve timing out of adjustment. 4. Worn piston rings or cylinders. 5. Poor seating of valves. 6. Fouled spark plug. 7. Incorrect spark plug. 8. Clogged injector. 9. Throttle position sensor out of adjustment. 10. Clogged air cleaner element. 11. Imbalanced throttle valve synchronization. 12. Sucking air from throttle valve or vacuum hose. 13. Too much engine oil. 14. Defective fuel pump or ECM. 15. Defective crankshaft position sensor and ignition coil. Defective control circuit or sensor 1. Low fuel pressure. 2. Defective throttle position sensor. 3. Defective intake air temp. sensor. 4. Defective camshaft position sensor. 5. Defective crankshaft position sensor. 6. Defective gear position switch. 7. Defective intake air pressure sensor. 8. Defective atmospheric pressure sensor. 9. Defective ECM. 10. Imbalanced throttle valve synchronization. 11. Throttle position sensor out of adjustment. 12. Defective fuel tank pressure control valve.	Adjust. Replace. Adjust. Replace. Repair. Clean or replace. Adjust or replace. Clean. Adjust. Clean. Adjust. Retighten or replace. Drain out excess oil. Replace. Replace. Repair or replace. Replace. Replace. Replace. Replace. Replace. Replace. Adjust. Adjust. Replace.

Complaint	Symptom and possible causes	Remedy
Engine overheats.	<p>Defective engine internal parts</p> <ol style="list-style-type: none"> 1. Heavy carbon deposit on piston crowns. 2. Not enough oil in the engine. 3. Defective oil pump or clogged oil circuit. 4. Sucking air from intake pipes. 5. Use of incorrect engine oil. 6. Defective cooling system. <p>Lean fuel/air mixture</p> <ol style="list-style-type: none"> 1. Short-circuited intake air pressure sensor/lead wire. 2. Short-circuited intake air temp. sensor/lead wire. 3. Sucking air from intake pipe joint. 4. Defective fuel injector. 5. Defective engine coolant temp. sensor. <p>The other factors</p> <ol style="list-style-type: none"> 1. Ignition timing too advanced due to defective timing advance system (engine coolant temp. sensor, gear position switch, crankshaft position sensor and ECM.) 	<p>Clean. Add oil. Replace or clean. Retighten or replace. Change. See radiator section.</p> <p>Repair or replace. Repair or replace. Repair or replace. Replace. Replace.</p> <p>Replace.</p>
Dirty or heavy exhaust smoke.	<ol style="list-style-type: none"> 1. Too much engine oil in the engine. 2. Worn piston rings or cylinders. 3. Worn valve guides. 4. Scored or scuffed cylinder walls. 5. Worn valve stems. 6. Defective stem seal. 7. Worn oil ring side rails. 	<p>Check with inspection window. Drain excess oil.</p> <p>Replace. Replace. Replace. Replace. Replace. Replace.</p>
Slipping clutch.	<ol style="list-style-type: none"> 1. Weakened clutch springs. 2. Worn or distorted pressure plate. 3. Distorted clutch plates. 	<p>Replace. Replace. Replace.</p>
Dragging clutch.	<ol style="list-style-type: none"> 1. Some clutch spring weakened while others are not. 2. Distorted pressure plate or clutch plate. 	<p>Replace. Replace.</p>

CVT

Complaint	Symptom and possible causes	Remedy
CVT is noisy.	<ol style="list-style-type: none"> 1. Worn or burnt bearing. 2. Primary pulley shim misadjusted. 3. Broken CVT motor gear. 4. Broken or damaged secondary pulley fan. 	Replace. Adjust. Replace. Replace.
Slipping CVT belt.	<ol style="list-style-type: none"> 1. Worn CVT belt. 2. Worn pulley face. 3. Entrance of foreign substance 	Replace. Replace. Clean or adjust.
CVT will not shift.	<ol style="list-style-type: none"> 1. Defective handle switches. 2. Defective sensors. 3. CVT motor locking. 	Repair. Replace. Replace.

RADIATOR (COOLING SYSTEM)

Complaint	Symptom and possible causes	Remedy
Engine overheats.	<ol style="list-style-type: none"> 1. Not enough engine coolant. 2. Radiator core clogged with dirt or scale. 3. Faulty cooling fan. 4. Defective cooling fan thermo-switch. 5. Clogged water passage. 6. Air trapped in the cooling circuit 7. Defective water pump. 8. Use of incorrect engine coolant. 9. Defective thermostat 	Add engine coolant. Clean. Repair or replace. Replace. Clean. Bleed air Replace. Replace. Replace.
Engine overcools.	<ol style="list-style-type: none"> 1. Defective cooling fan thermo-switch. 2. Extremely cold weather. 3. Defective thermostat. 	Replace. Put on radiator cover. Replace.

CHASSIS

Complaint	Symptom and possible causes	Remedy
Heavy steering.	<ol style="list-style-type: none"> 1. Overtightened steering stem nut. 2. Broken bearing in steering stem. 3. Distorted steering stem. 4. Not enough pressure in tires. 	Adjust. Replace. Replace. Adjust.
Wobbly handlebars.	<ol style="list-style-type: none"> 1. Loss of balance between right and left front forks. 2. Distorted front fork. 3. Distorted front axle or crooked tire. 4. Loose steering stem nut. 5. Worn or incorrect tire or wrong tire pressure. 6. Worn bearing/race in steering stem. 	Replace. Repair or replace. Replace. Adjust. Adjust or replace. Replace.
Wobbly front wheel.	<ol style="list-style-type: none"> 1. Distorted wheel rim. 2. Worn front wheel bearings. 3. Defective or incorrect tire. 4. Loose axle or axle pinch bolt. 5. Incorrect front fork oil level. 	Replace. Replace. Replace. Retighten. Adjust.
Front suspension too soft.	<ol style="list-style-type: none"> 1. Weakened springs. 2. Not enough fork oil. 3. Wrong viscous fork oil. 	Replace. Replenish. Replace.
Front suspension too stiff.	<ol style="list-style-type: none"> 1. Too viscous fork oil. 2. Too much fork oil. 3. Bent front axle. 	Replace. Drain excess oil. Replace.
Noisy front suspension.	<ol style="list-style-type: none"> 1. Not enough fork oil. 2. Loose bolts on suspension. 	Replenish. Retighten.
Wobbly rear wheel.	<ol style="list-style-type: none"> 1. Distorted wheel rim. 2. Worn rear wheel bearing or swingarm bearings. 3. Defective or incorrect tire. 4. Loose nuts or bolts on rear suspension and rear swingarm. 	Replace. Replace. Replace. Retighten.
Rear suspension too soft.	<ol style="list-style-type: none"> 1. Weakened spring of shock absorber. 2. Leakage of oil from shock absorber. 3. Improperly set rear spring unit adjuster. 	Replace. Replace. Adjust.
Rear suspension too stiff.	<ol style="list-style-type: none"> 1. Bent shock absorber shaft. 2. Over tightened swingarm pivot bolt. 3. Worn swingarm and suspension bearings. 4. Improperly set rear suspension adjuster. 	Replace. Retighten. Replace. Adjust.
Noisy rear suspension.	<ol style="list-style-type: none"> 1. Loose nuts or bolts on rear suspension. 2. Worn swingarm bearings. 	Retighten. Replace.

BRAKES

Complaint	Symptom and possible causes	Remedy
Insufficient brake power.	<ol style="list-style-type: none"> 1. Leakage of brake fluid from hydraulic system. 2. Worn pads. 3. Oil adhesion on friction surface of pads/shoe. 4. Worn disc. 5. Air in hydraulic system. 6. Not enough brake fluid in the reservoir. 	Repair or replace. Replace. Clean disc and pads. Replace. Bleed air. Replenish.
Brake squeaking.	<ol style="list-style-type: none"> 1. Carbon adhesion on pad surface. 2. Tilted pad. 3. Damaged wheel bearing. 4. Loose front-wheel axle or rear-wheel axle. 5. Worn pads or disc. 6. Foreign material in brake fluid. 7. Clogged return port of master cylinder. 	Repair surface with sandpaper. Correct pad fitting or replace. Replace. Tighten to specified torque. Replace. Replace brake fluid. Disassemble and clean master cylinder.
Excessive brake lever stroke.	<ol style="list-style-type: none"> 1. Air in hydraulic system. 2. Insufficient brake fluid. 3. Improper quality of brake fluid. 	Bleed air. Replenish fluid to specified level; bleed air. Replace with correct fluid.
Leakage of brake fluid.	<ol style="list-style-type: none"> 1. Insufficient tightening of connection joints. 2. Cracked hose. 3. Worn piston and/or cup. 	Tighten to specified torque. Replace. Replace piston and/or cup.
Brake drags.	<ol style="list-style-type: none"> 1. Rusty part. 2. Insufficient brake lever or brake pedal pivot lubrication. 3. Malfunction of brake lock. 	Clean and lubricate. Lubricate. Adjust or replace.

ELECTRICAL

Complaint	Symptom and possible causes	Remedy
No sparking or poor sparking.	<ol style="list-style-type: none"> 1. Defective ignition coil/plug cap or camshaft position sensor. 2. Defective spark plugs. 3. Defective generator. 4. Defective ECM. 5. Defective load over sensor. 6. Open-circuited wiring connections. 	Replace. Replace. Replace. Replace. Check and repair.
Spark plugs soon become fouled with carbon.	<ol style="list-style-type: none"> 1. Mixture too rich. 2. Idling speed set too high. 3. Incorrect gasoline. 4. Dirty air cleaner element. 5. Too cold spark plugs. 	Consult FI system. Adjust fast idle or throttle stop screw. Change. Clean or replace. Replace with hot type plugs.
Spark plugs become fouled too soon.	<ol style="list-style-type: none"> 1. Worn piston rings. 2. Worn piston or cylinders. 3. Excessive clearance of valve stems in valve guides. 4. Worn stem oil seal. 	Replace. Replace. Replace. Replace.
Spark plug electrodes overheat or burn.	<ol style="list-style-type: none"> 1. Too hot spark plugs. 2. Overheated the engine. 3. Loose spark plugs. 4. Too lean mixture. 	Replace with cold type plugs. Tune up. Retighten. Consult FI system.
Generator does not charge.	<ol style="list-style-type: none"> 1. Open- or short-circuited lead wires, or loose lead connections. 2. Short-circuited, grounded or open generator coils. 3. Short-circuited or punctured regulator/rectifier. 	Repair or replace or retighten. Replace. Replace.
Generator does charge, but charging rate is below the specification.	<ol style="list-style-type: none"> 1. Lead wires tend to get short- or open-circuited or loosely connected at terminals. 2. Grounded or open-circuited stator coils or generator. 3. Defective regulator/rectifier. 4. Defective cell plates in the battery. 	Repair or retighten. Replace. Replace. Replace the battery.
Generator over-charges.	<ol style="list-style-type: none"> 1. Internal short-circuit in the battery. 2. Damaged or defective resistor element in the regulator/rectifier. 3. Poorly grounded regulator/rectifier. 	Replace the battery. Replace. Clean and tighten ground connection.
Unstable charging.	<ol style="list-style-type: none"> 1. Lead wire insulation frayed due to vibration, resulting in intermittent short-circuiting. 2. Internally short-circuited generator. 3. Defective regulator/rectifier. 	Repair or replace. Replace. Replace.
Starter button is not effective.	<ol style="list-style-type: none"> 1. Run down battery. 2. Defective switch contacts. 3. Brushes not seating properly on starter motor commutator. 4. Defective starter relay or starter interlock switch. 5. Defective main fuse. 	Repair or replace. Replace. Repair or replace. Replace. Replace.

BATTERY

Complaint	Symptom and possible causes	Remedy
"Sulfation", acidic white powdery substance or spots on surfaces of cell plates.	<ol style="list-style-type: none"> 1. Cracked battery case 2. Battery has been left in a run-down condition for a long time. 	<p>Replace the battery.</p> <p>Replace the battery.</p>
Battery runs down quickly.	<ol style="list-style-type: none"> 1. Trouble in charging system. 2. Cell plates have lost much of their active material as a result of overcharging. 3. Internal short-circuit in the battery. 4. Too low battery voltage. 5. Too old battery. 	<p>Check the generator, regulator/rectifier and circuit connections and make necessary adjustments to obtain specified charging operation.</p> <p>Replace the battery, and correct the charging system.</p> <p>Replace the battery.</p> <p>Recharge the battery fully.</p> <p>Replace the battery.</p>
Battery "sulfation".	<ol style="list-style-type: none"> 1. Incurrent charging rate. (When not in use battery should be checked at least once a month to avoid sulfation.) 2. The battery was left unused in a cold climate for too long. 	<p>Replace the battery.</p> <p>Replace the battery if badly sulfated.</p>

WIRING HARNESS, CABLE AND HOSE ROUTING

WIRING HARNESS ROUTING

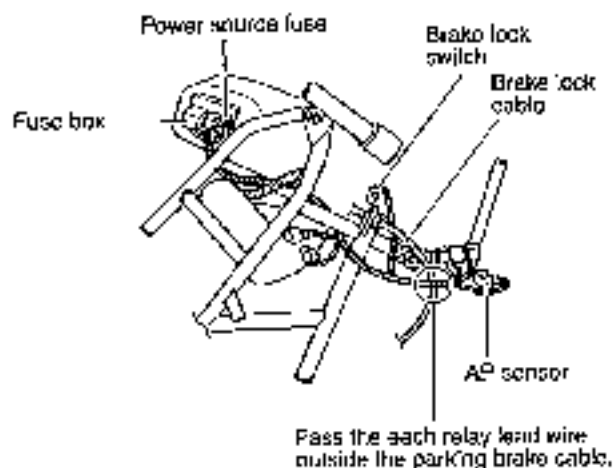
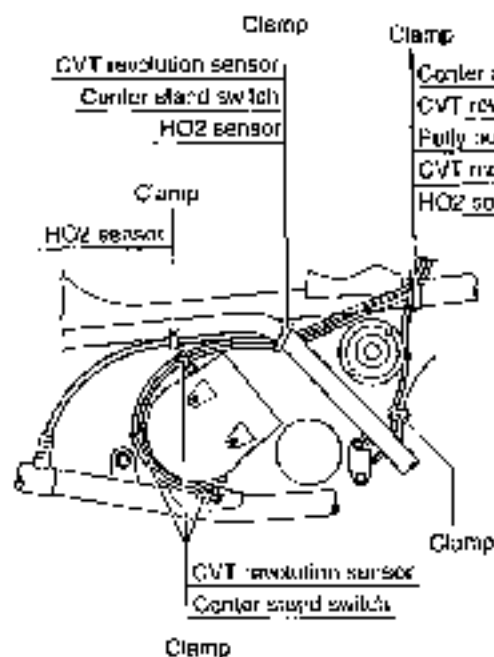
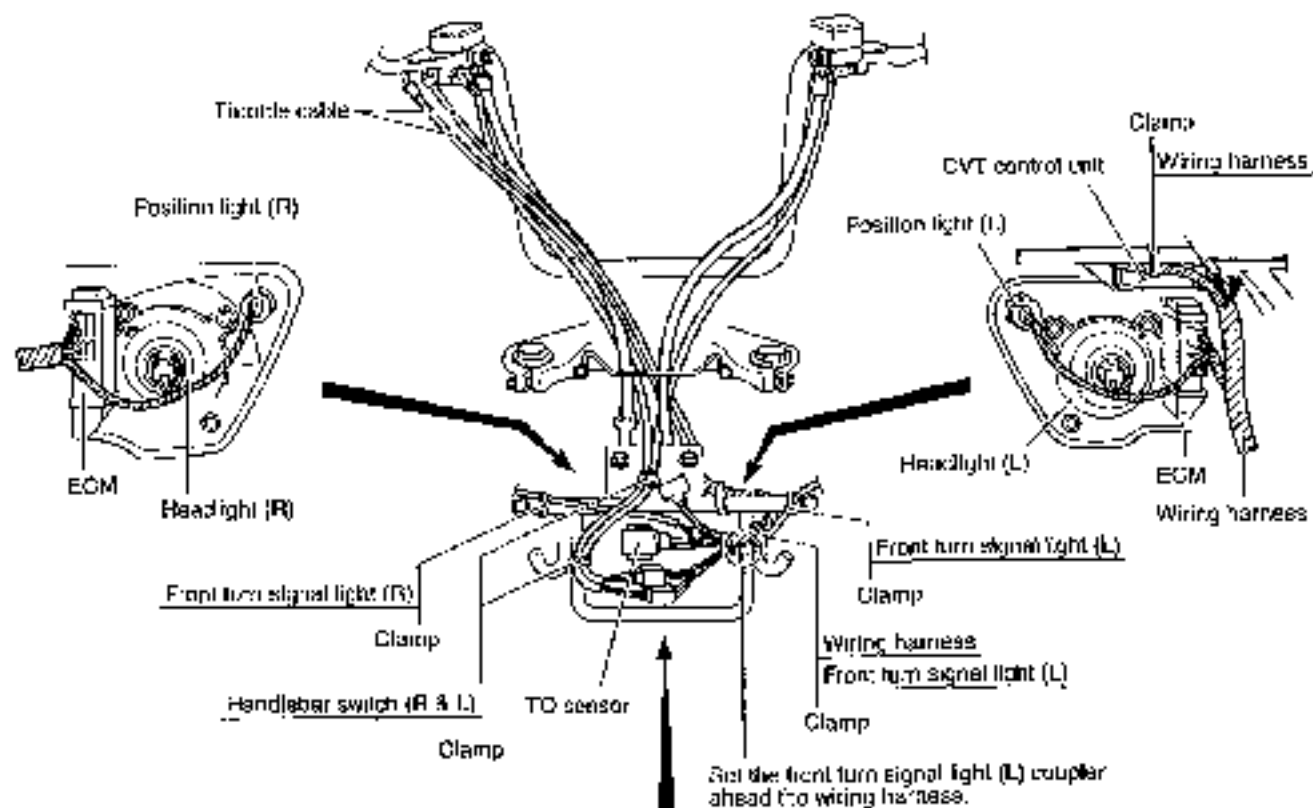

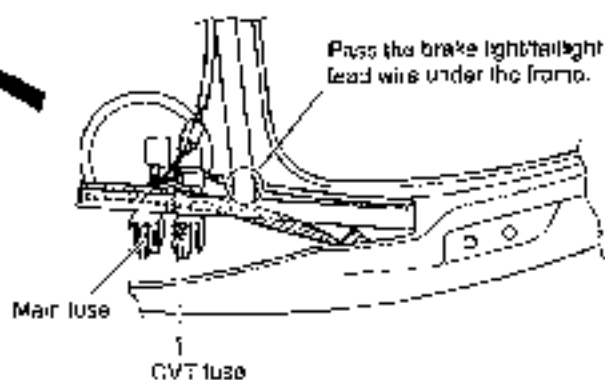
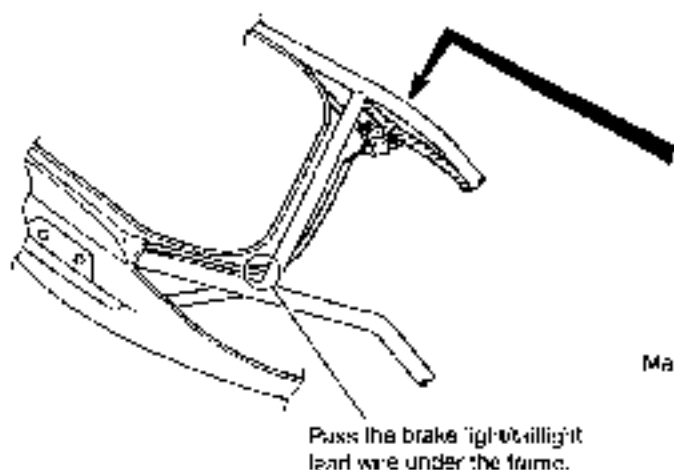
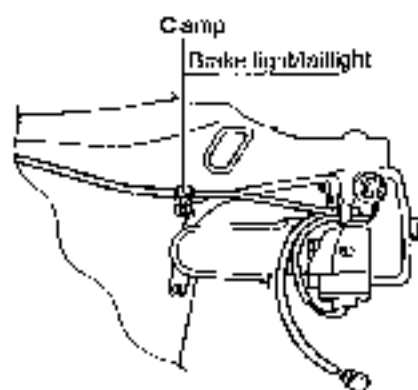
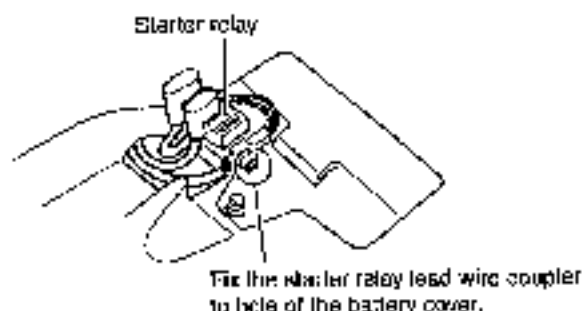
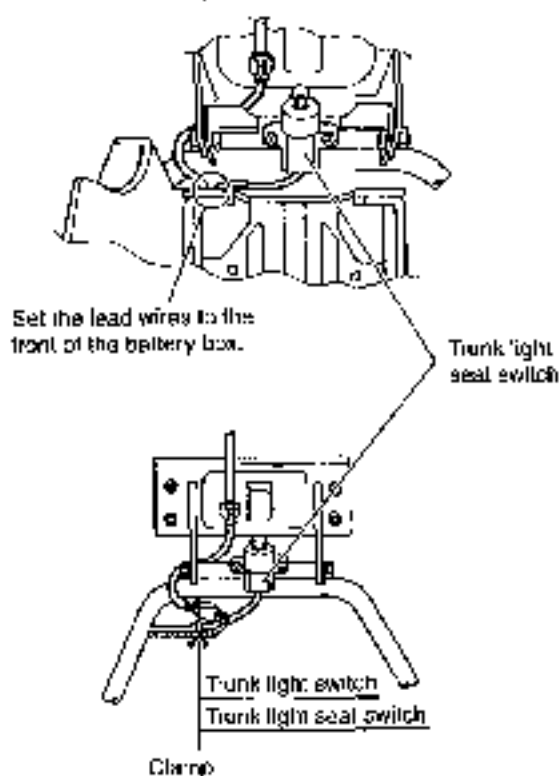
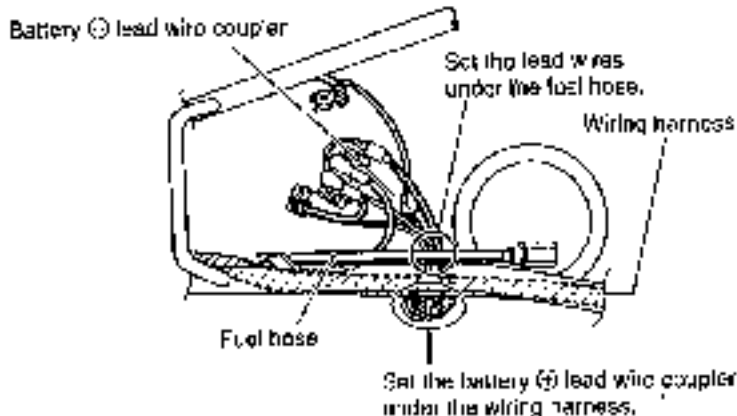
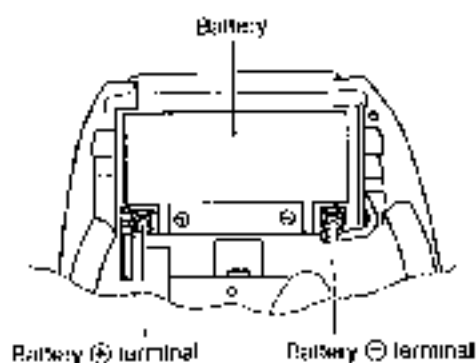

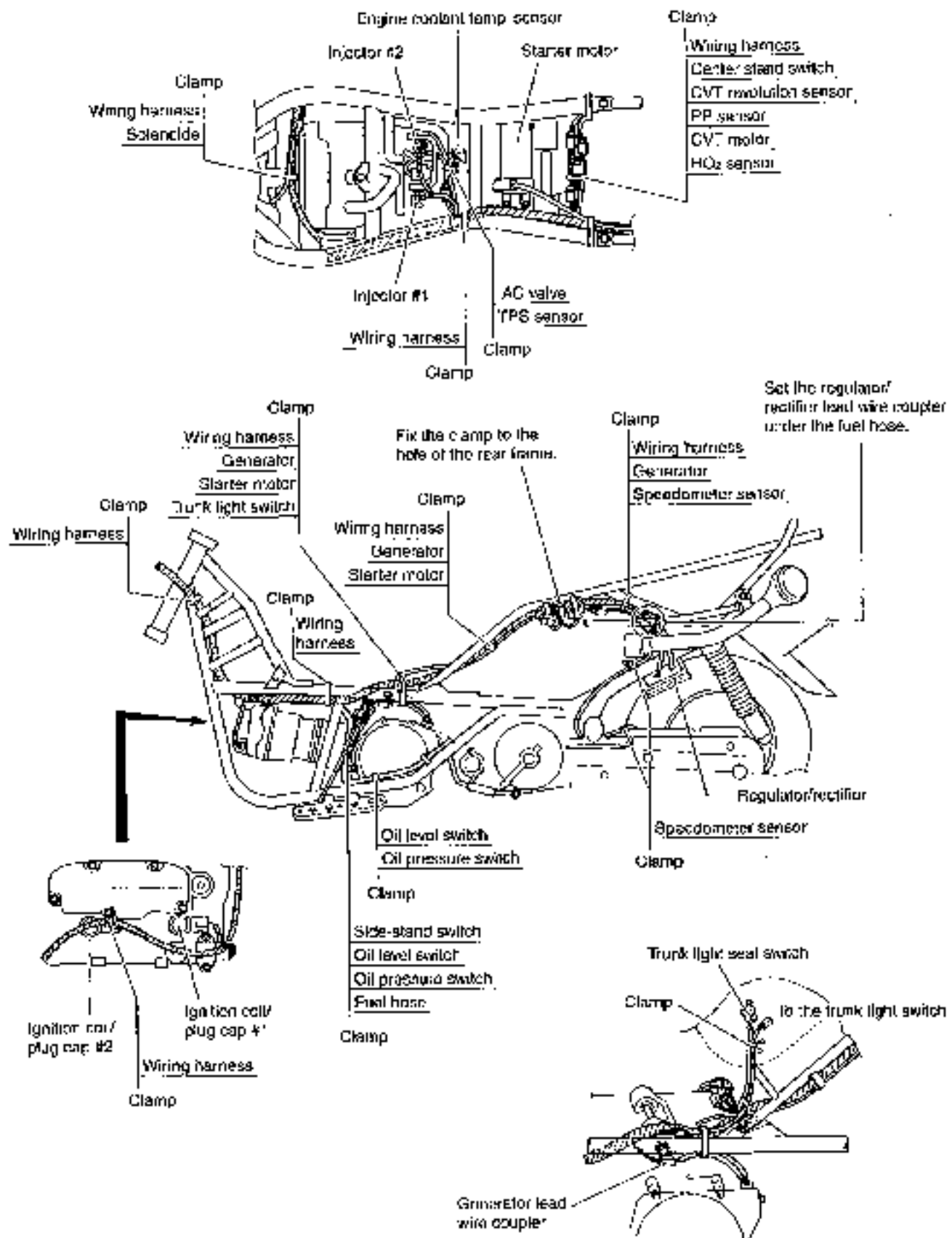

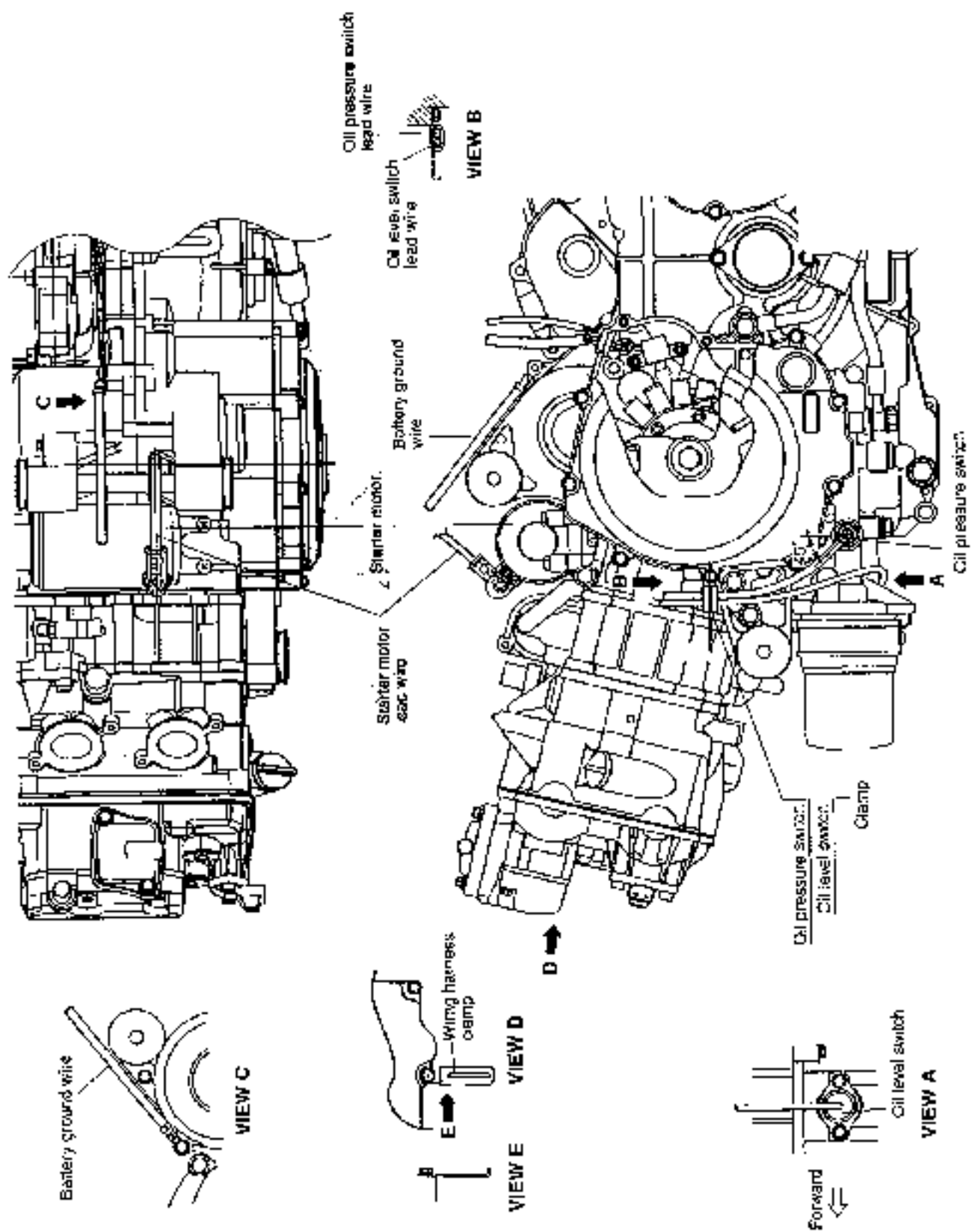

CABLE ROUTING

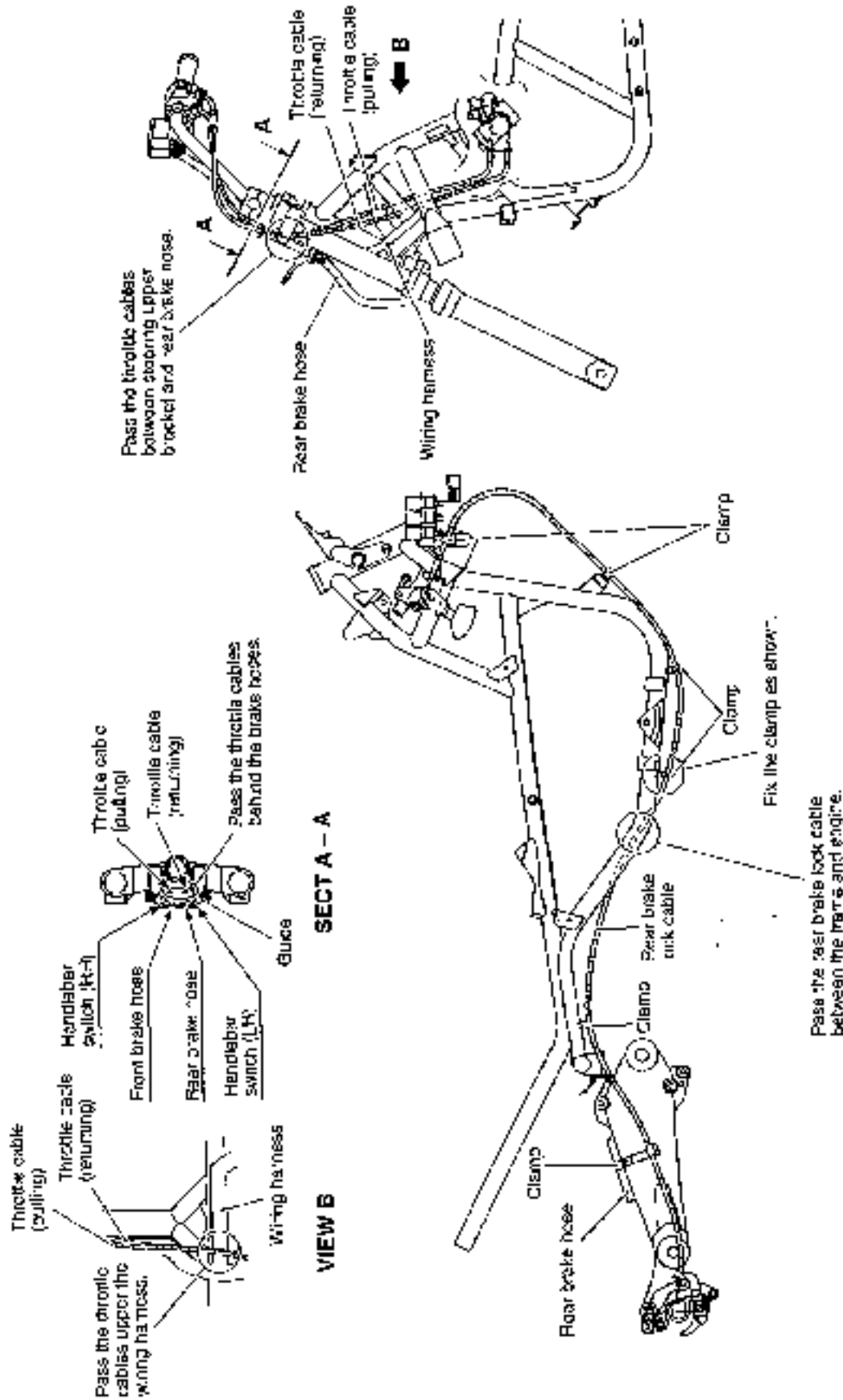

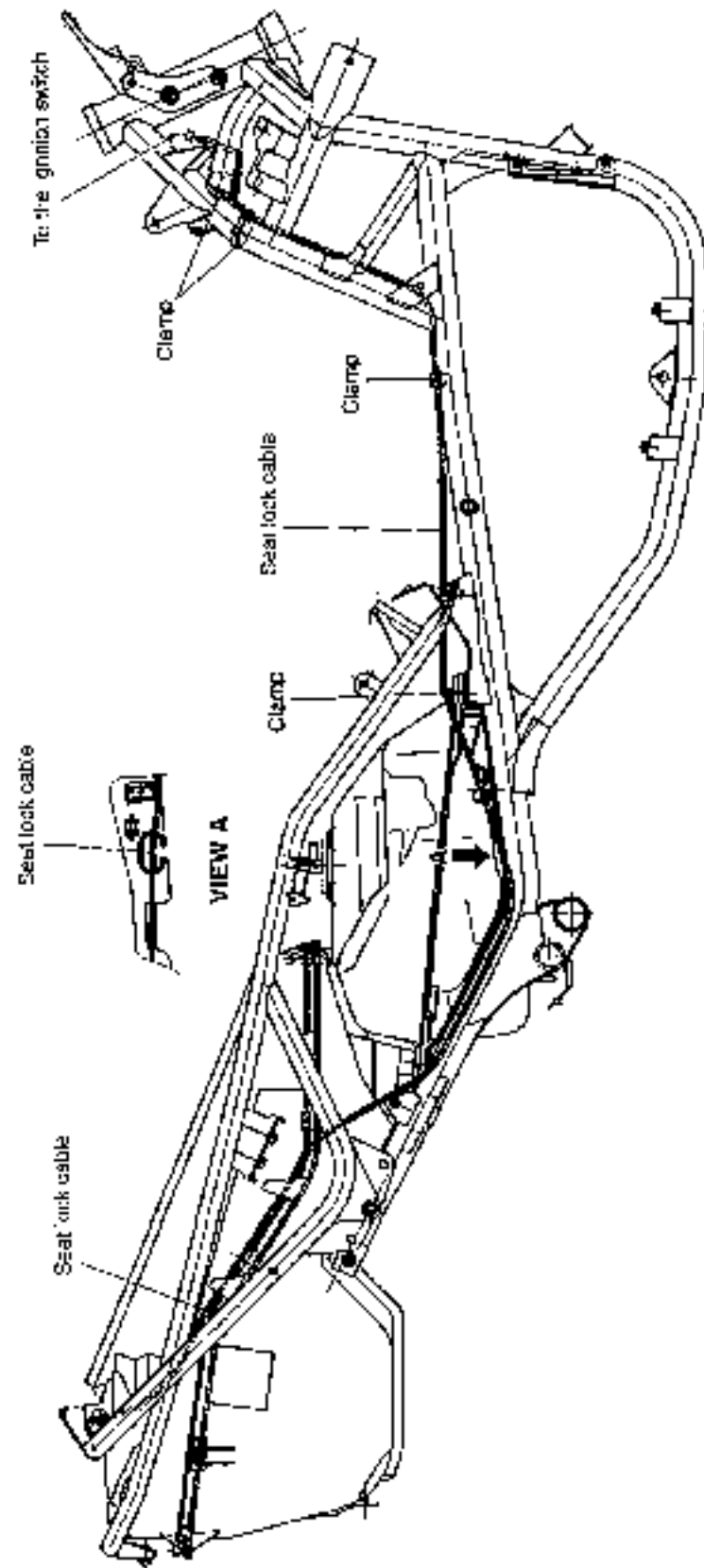

THROTTLE BODY INSTALLATION/HOSE ROUTING

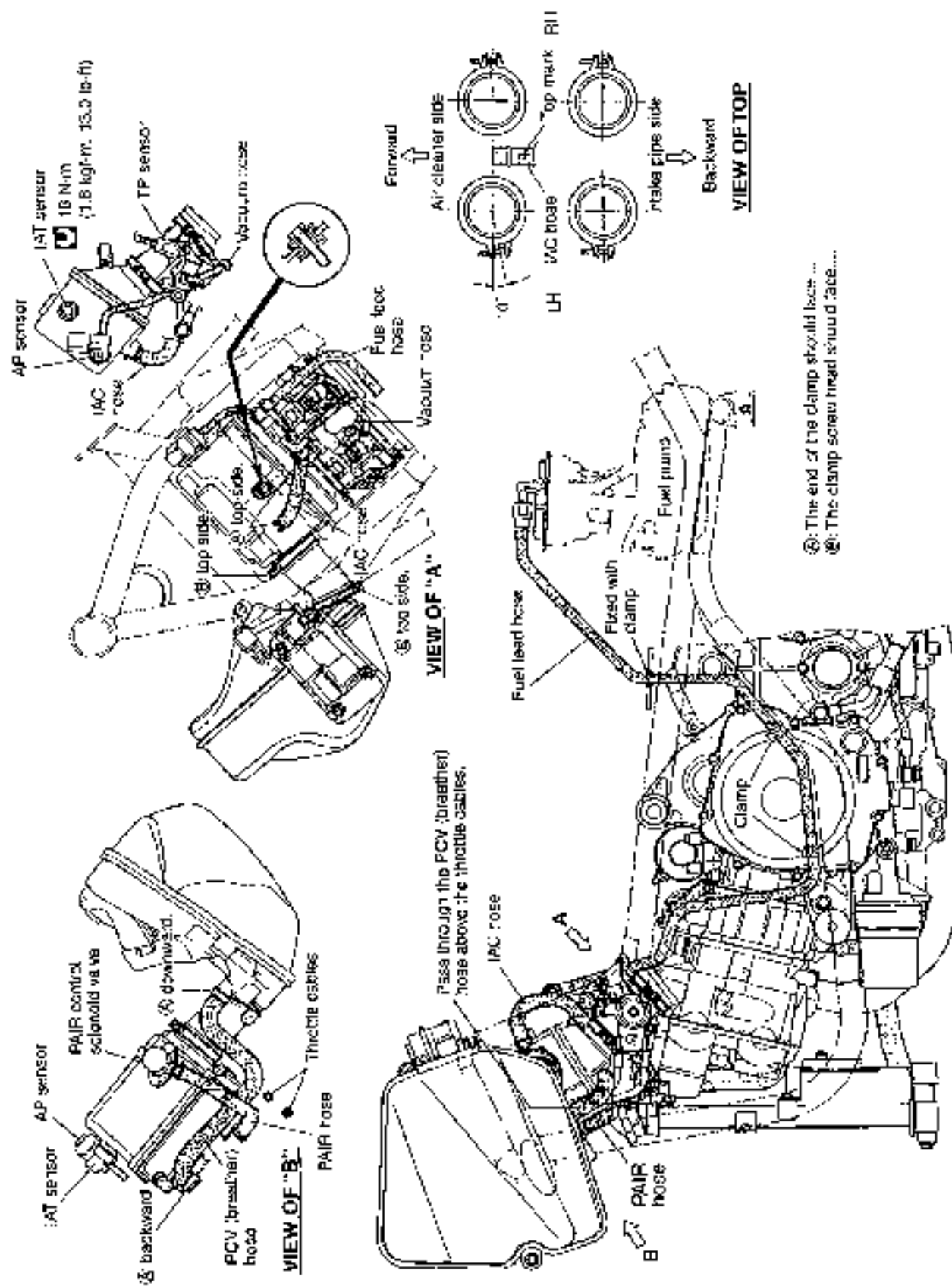

FUEL TANK MOUNTING

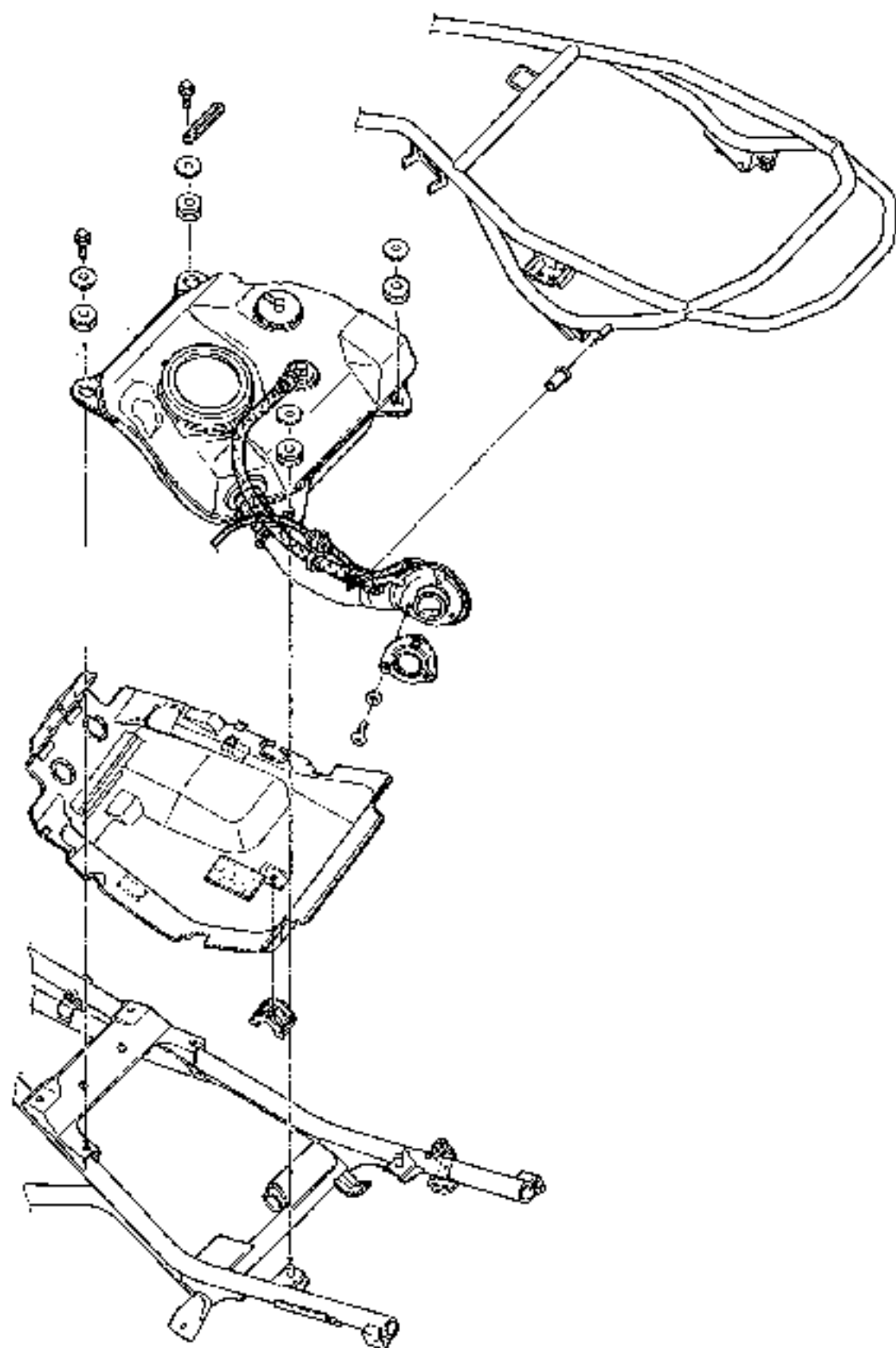

FUEL TANK HOSE ROUTING

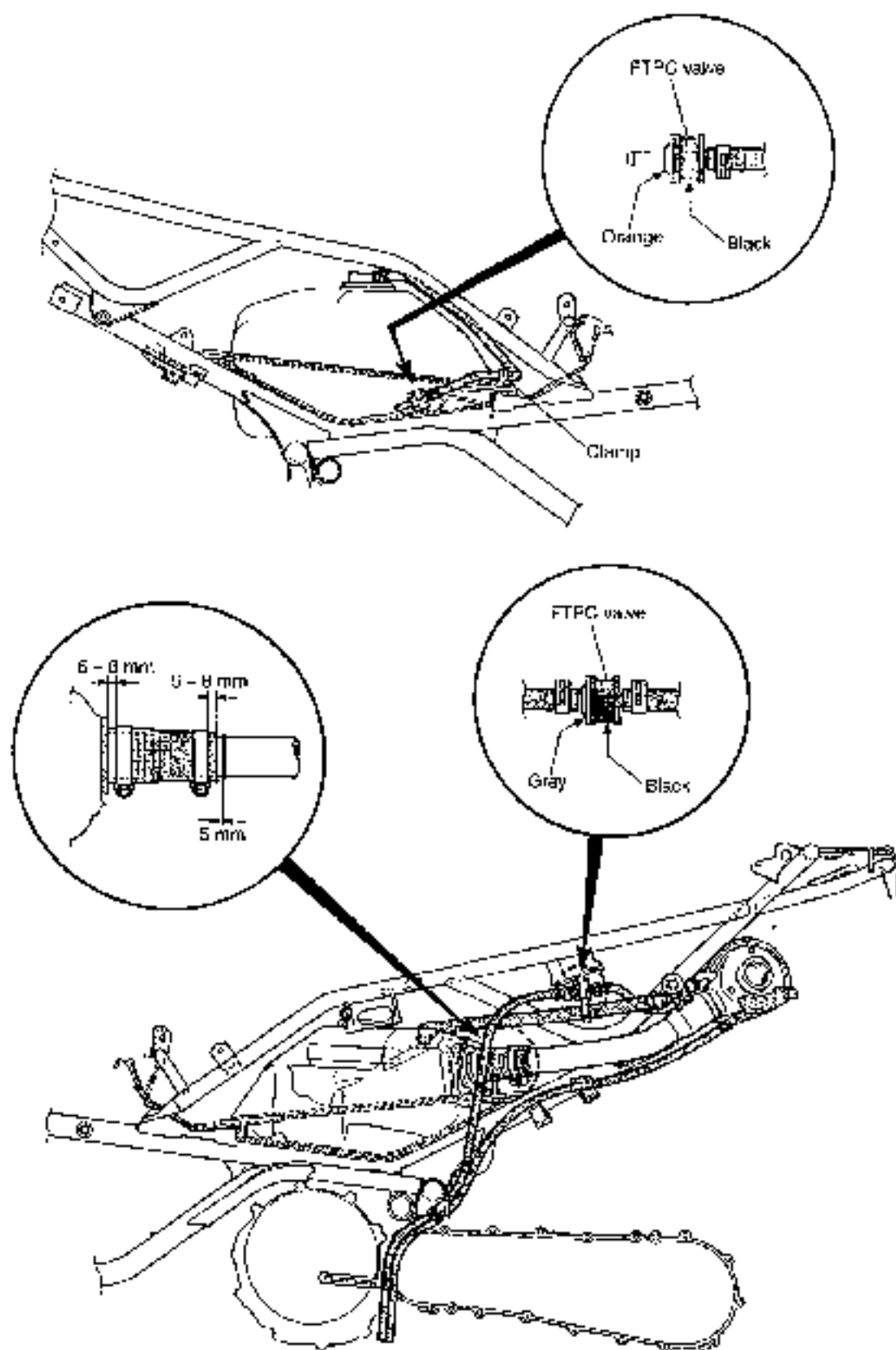

RADIATOR HOSE ROUTING

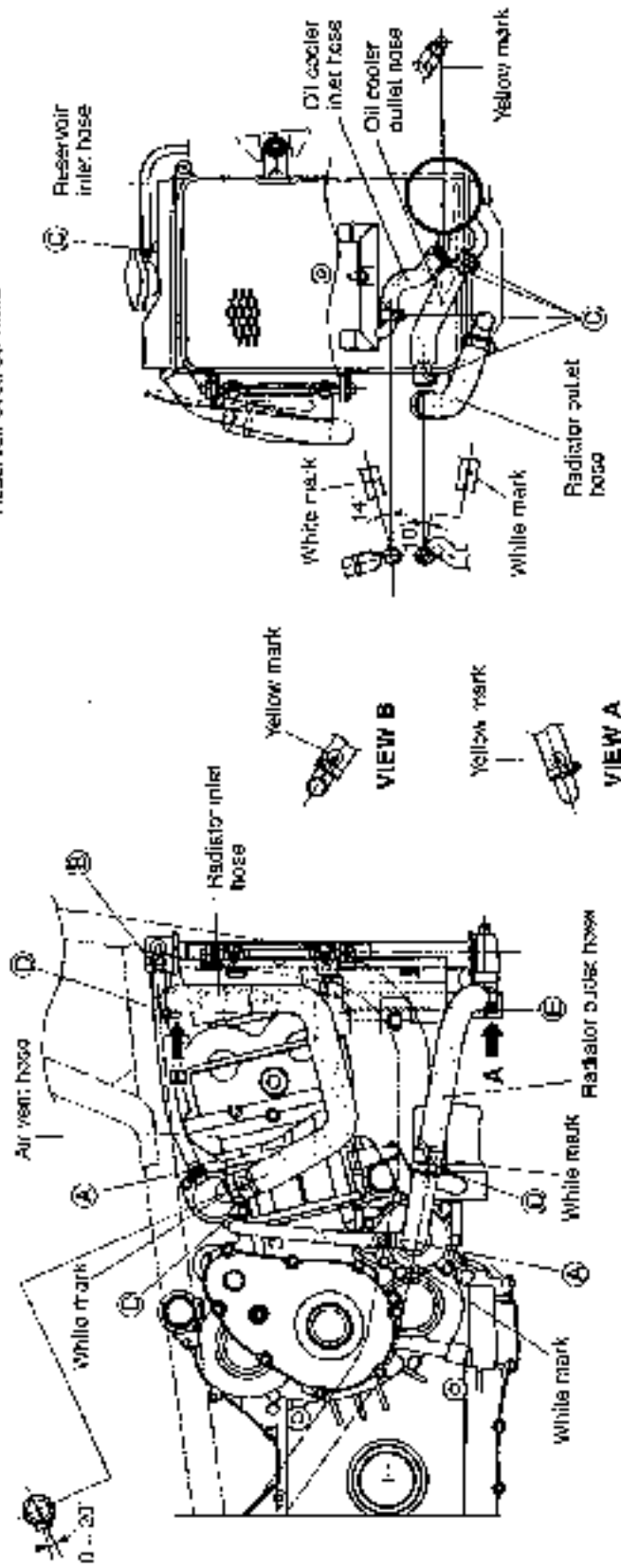
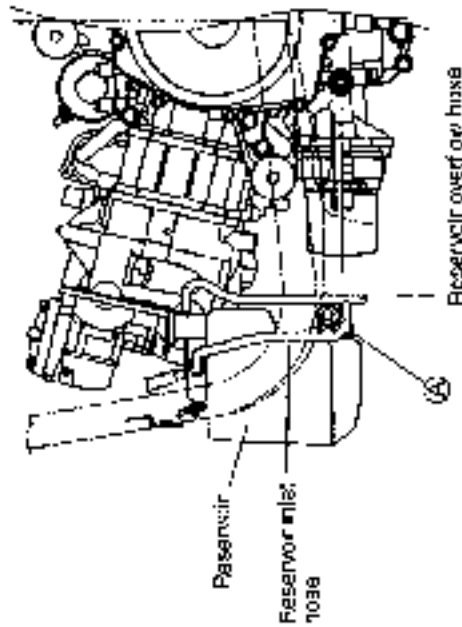
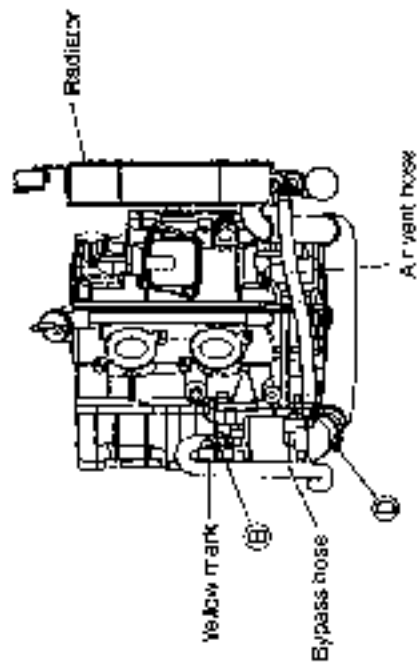

- Ⓜ : Face the lip of clamp to the right.
- Ⓝ : Face the head of screw to the right.
- Ⓟ : Face the head of screw to the top.
- Ⓠ : Face the lip of clamp to the bottom.

FRONT BRAKE HOSE ROUTING

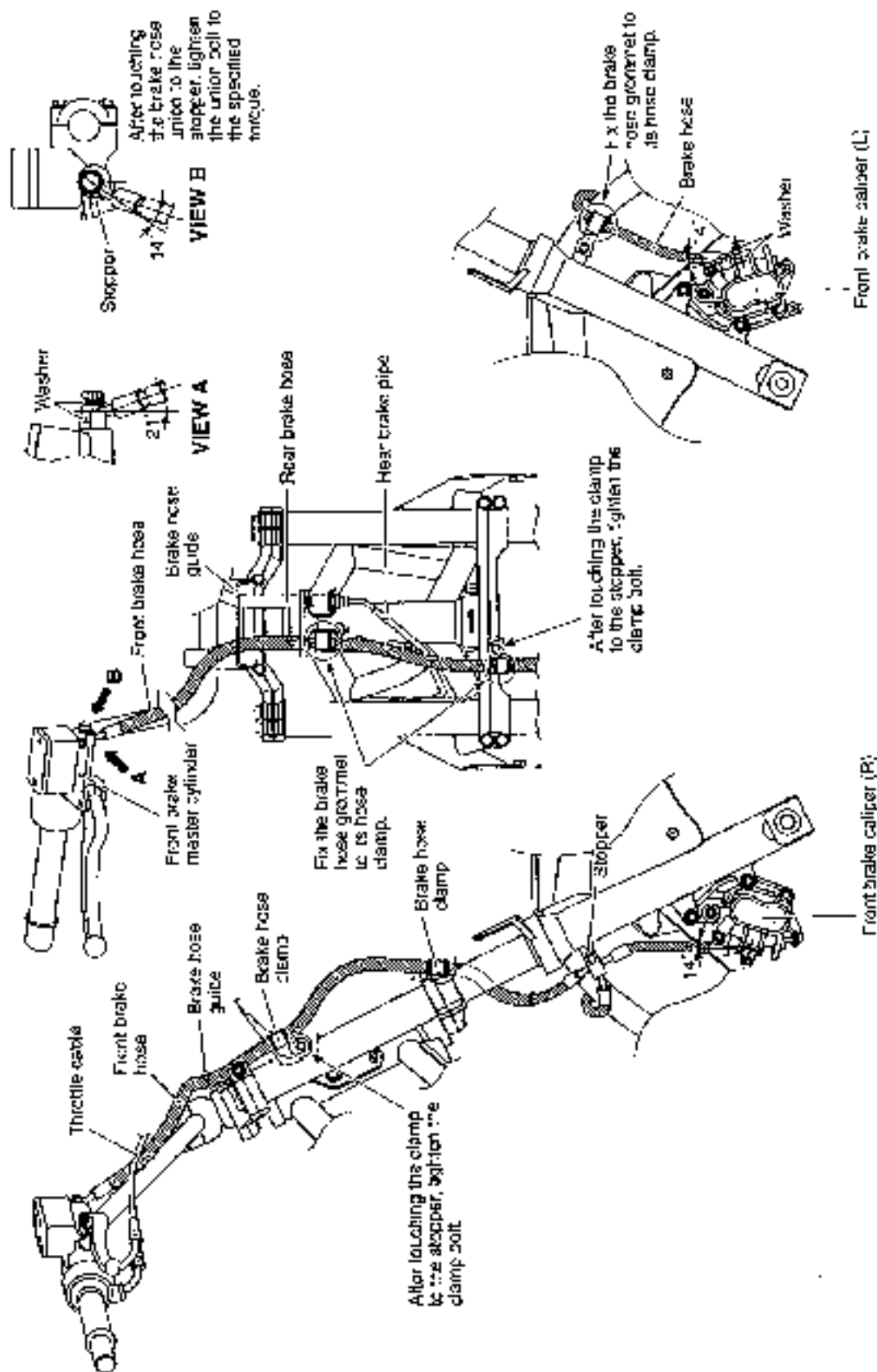

REAR BRAKE HOSE ROUTING

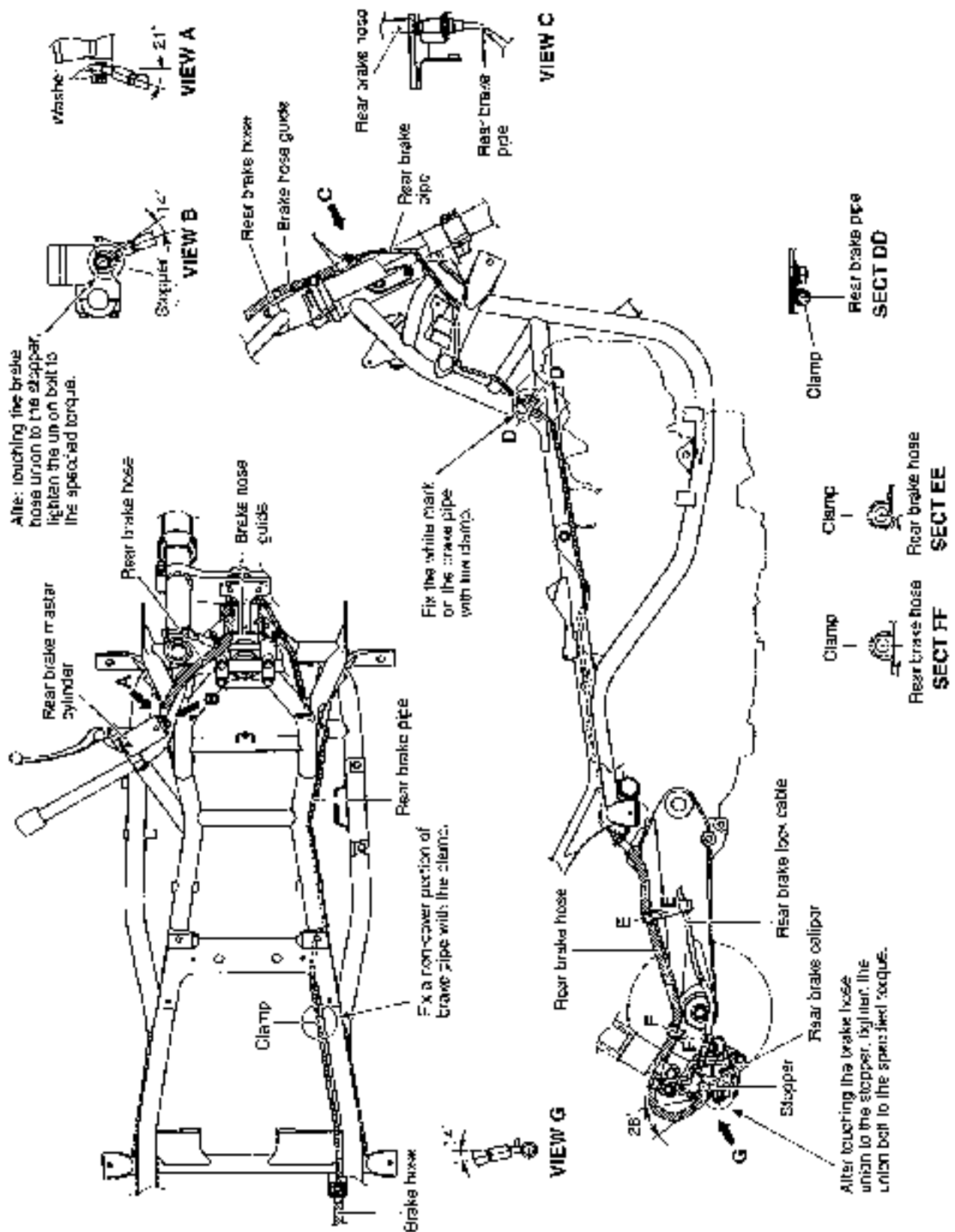



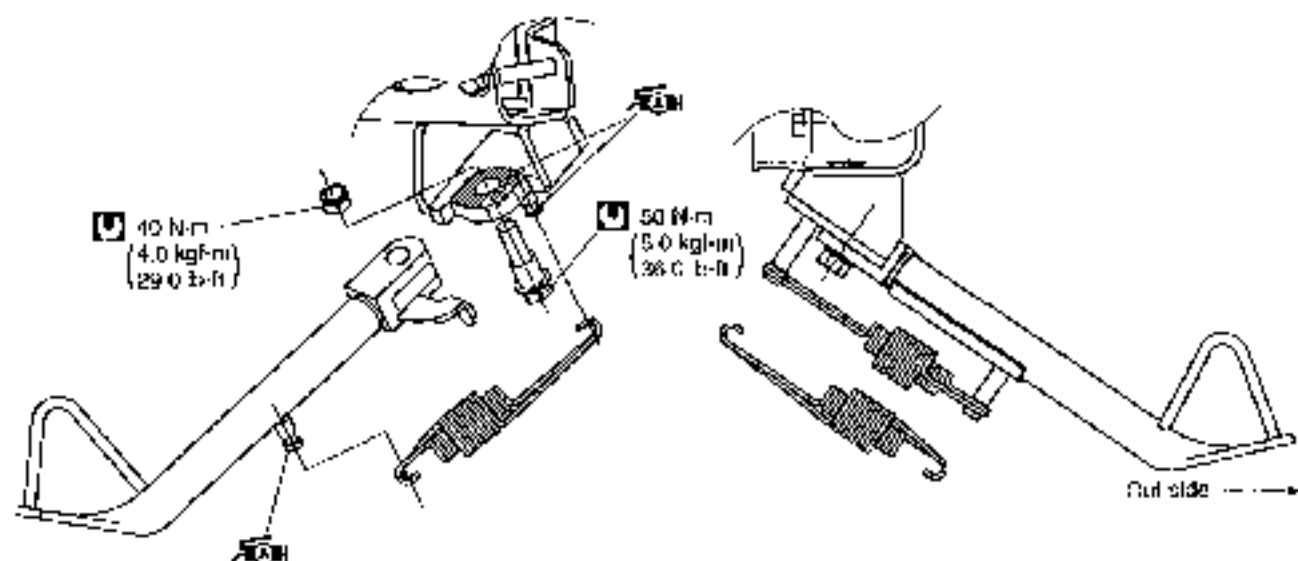

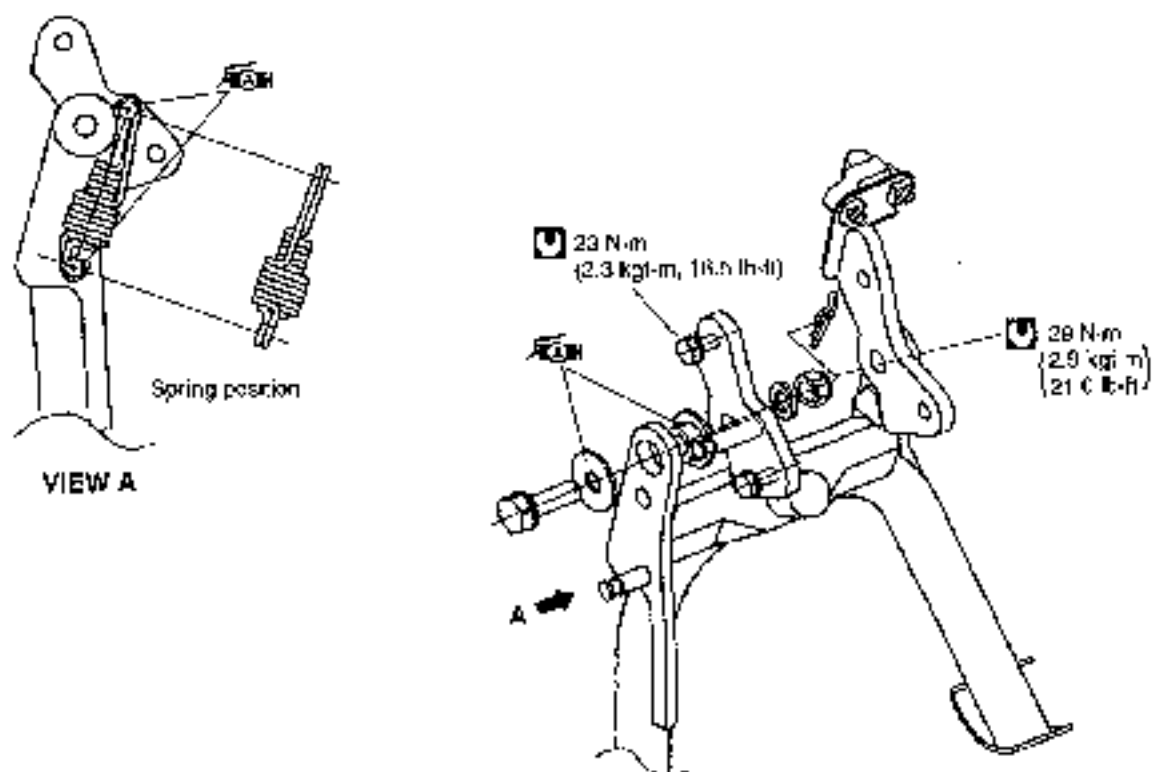

SIDE-STAND SET-UP





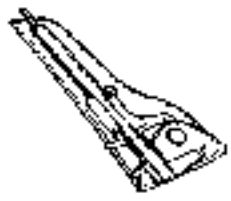

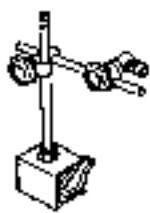
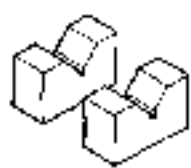





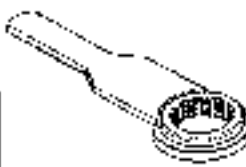



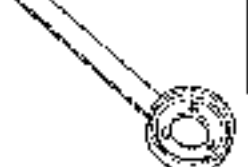
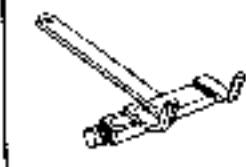

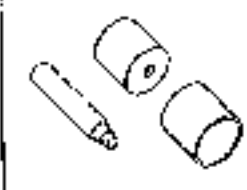
CENTER STAND SET-UP



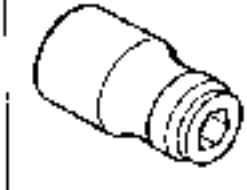

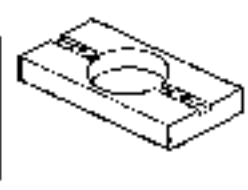



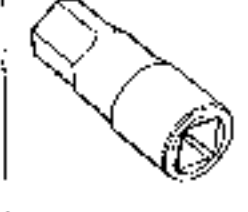

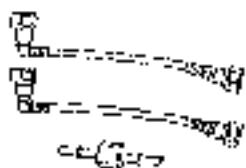
SPECIAL TOOLS

				
09900-06107 Snap ring pliers	09900-06108 Snap ring pliers	09900-09004 Impact driver set	09900-18710 Hexagon socket 12 mm	09900-20102 Vernier calipers
				
09900-20202 Micrometer (25 - 50 mm)	09900-20204 Micrometer (75 - 100 mm)	09900-20205 Micrometer (0 - 25 mm)	09900-20508 Cylinder gauge set	09900-20602 Dial gauge (1/1000 mm, 1 mm)
				
09900-20605 Dial gauge	09900-20607 Dial gauge (1/100 mm, 10 mm)	09900-20701 Magnetic stand	09900-20803 09900-20806 Thickness gauge	09900-20805 Tire depth gauge
				
09900-21304 V-block (100 mm)	09900-22301 09900-22302 Plastigauge	09900-22401 Small bore gauge (10 - 18 mm)	09900-25008 Multi circuit tester set	09910-32812 Crankshaft installer
				
09910-32850 Crankshaft installer attachment	09913-60121 Oil seal remover	09913-60210 09913-60230 Journal bearing remover/installer	09913-60241 Journal bearing holder	09913-60812 or 09913-61110 or 09913-61510 Bearing puller

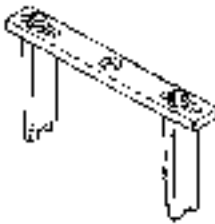
 <p>09913-70210 Bearing installer set</p>	 <p>09913-75310 Bearing installer</p>	 <p>09915-40610 Oil filter wrench</p>	 <p>09915-83311 Compression gauge attachment</p>	 <p>09916-74511 Compression gauge</p>
 <p>09915-74521 Oil pressure gauge hose</p>	 <p>09915-74532 Oil pressure gauge adaptor</p>	 <p>09915-77331 Meter (for high pressure)</p>	 <p>09916-10911 Valve lapper set</p>	 <p>09916-14510 Valve spring compressor</p>
 <p>09916-14521 Valve spring compressor attachment</p>	 <p>09916-20630 Valve seat cutter head (N-126)</p>	 <p>09916-20640 Solid pilot (N-100-4.5)</p>	 <p>09916-21111 Valve seat cutter set</p>	 <p>09916-33210 Valve guide reamer (4.5 mm)</p>
 <p>09916-34542 Reamer handle</p>	 <p>09916-34561 Valve guide reamer (11.3 mm)</p>	 <p>09916-43210 Valve guide remover/installer</p>	 <p>09916-44930 Attachment</p>	 <p>09916-84511 Tweezers</p>
 <p>09917-23711 Ring nut wrench</p>	 <p>09918-53910 Chain tensioner lock tool</p>	 <p>09920-13120 Crankcase separating tool</p>	 <p>09920-31010 CVT primary pulley shaft holder</p>	 <p>09920-31020 Extension handle</p>

 <p>09920-31030 CVT secondary pulley shaft holder</p>	 <p>09920-31040 CVT primary pulley shaft adaptor remover</p>	 <p>09920-31050 CVT guide</p>	 <p>09920-33530 Clutch spring compressor</p>	 <p>09920-34830 Starter clutch holder</p>
 <p>09920-58740 Clutch sleeve hub holder</p>	 <p>09921-20240 Bearing remover set</p>	 <p>09924-74570 Final drive gear bearing installer/remover</p>	 <p>09924-64510 Bearing installer set</p>	 <p>09925-18011 Steering bearing installer</p>
 <p>09930-11930 Torx bit JT30H</p>	 <p>09930-11940 Bit holder</p>	 <p>09930-30450 Rotor remover</p>	 <p>09930-40113 Rotor holder</p>	 <p>09930-73170 Starter torque limiter holder</p>
 <p>09930-73120 Starter torque limiter socket</p>	 <p>09930-82710 Mode selection switch</p>	 <p>09930-82720 Mode selection switch</p>	 <p>09940-14911 Steering stem nut wrench</p>	 <p>09940-30230 Socket hexagon 17 mm</p>

 <p>09940-40211 Fuel pressure gauge adapter</p>	 <p>08940-40220 Fuel pressure gauge hose attachment</p>	 <p>00940-52861 Front fork oil seal installer</p>	 <p>09940-92720 Spring scale</p>	 <p>09941-34513 Steering race installer</p>
 <p>09941-51010 Ring locknut wrench</p>	 <p>09941-54911 Bearing outer race remover</p>	 <p>09943-74111 Fork oil level gauge</p>	 <p>09941-74911 Steering bearing installer</p>	

NOTE:

When ordering a special tool, please confirm whether it is available or not.

TIGHTENING TORQUE ENGINE

ITEM		N·m	kgf·m	lb·ft
Cylinder head cover bolt	Tighten lightly.	10	1.0	7.3
	Tighten firmly.	14	1.4	10.0
Cylinder head bolt	(M8)	25	2.5	1.8
	(M10)	Tighten lightly.	25	2.5
	Tighten firmly.	53	5.3	38.5
Cam chain tension adjuster bolt		10	1.0	7.3
Clutch spring set bolt		5.5	0.55	4.0
Clutch housing nut		70	7.0	50.5
Generator rotor bolt		160	16.0	115.5
Starter clutch bolt		55	5.5	40.0
Crankcase bolt	(M6)	11	1.1	8.0
	(M8)	26	2.6	19.0
Oil pressure switch		13	1.3	9.5
Engine oil drain plug 14		23	2.3	16.5
Transmission oil drain plug 12		21	2.1	15.0
Right crankcase cover bolt		11	1.1	8.0
Primary shaft cap bolt		11	1.1	8.0
Freezer cover		10	1.0	7.3
Spark plug		11	1.1	8.0
Cam shaft holder bolt		10	1.0	7.3
Cylinder head side bolt		14	1.4	10.0
Cam position sensor bolt		10	1.0	7.3
Oil level switch bolt		10	1.0	7.3
Oil cooler union bolt		70	7.0	5.0
Engine mount bolt		55	5.5	40.0
Oil plug bolt	(M10)	10	1.0	7.3
	(M10)	16	1.6	11.5
	(M14)	23	2.3	16.5
Exhaust pipe clamp bolt		23	2.3	16.5
Muffler mounting bolt		23	2.3	16.5
Oil hose union bolt (M10)		20	2.0	14.5
Oil return hose union ball (M14)		28	2.8	20.5
T/M breather plug		35	3.5	25.5
T/M oil filler		23	2.3	16.5
Oil level bolt		21	2.1	15.0
Timing cap		15	1.5	11.0
Drive shaft nut		105	10.5	76.0
Connecting rod bolt	Tighten lightly.	21	2.1	15.0
	Tighten firmly.		90°	
Starter motor mounting bolt		6	0.6	4.5
Starter motor lead wire nut		5	0.5	4.5

CVT

ITEM	N-m	kgf-m	lb-ft
CVT mounting bolt	50	5.0	36.0
Primary pulley stopper bolt	36	3.6	26.0
CVT cover bolt	22	2.2	16.0
Primary pulley shaft bolt	64	6.4	46.5
Secondary pulley shaft nut	226	22.6	163.5

CHASSIS

ITEM	N-m	kgf-m	lb-ft
Handlebar clamp bolt	23	2.3	16.5
Steering stem hose nut	65	6.5	47.0
Steering stem nut	45	4.5	32.5
Front fork upper clamp bolt	23	2.3	16.5
Front fork lower clamp bolt	23	2.3	16.5
Front fork cap bolt	23	2.3	16.5
Front fork cylinder bolt	30	3.0	21.5
Front axle	65	6.5	47.0
Front axle pinch bolt	23	2.3	16.5
Brake hose union bolt	23	2.3	16.5
Brake disc bolt (Front and Rear)	23	2.3	16.5
Brake air bleeder valve (Front and Rear)	7.5	0.75	5.5
Brake caliper mounting bolt (Front and Rear)	26	2.6	19.0
Brake master cylinder mounting bolt (Front and Rear)	10	1.0	7.0
Front brake caliper holder pin	13	1.3	9.5
Front brake pad mounting pin plug	2.5	0.25	1.8
Brake pad mounting pin (Front and Rear)	16	1.6	11.5
Rear brake caliper holder sliding pin	13	1.3	9.5
	23	2.3	16.5
Brake lock housing bolt	23	2.3	16.5
Brake lock adjuster locknut	9.5	0.95	7.0
Brake pipe nut	16	1.6	11.5
Swingarm pivot bolt	9.5	0.95	7.0
Swingarm pivot bolt locknut	100	10.0	72.5
Rear shock absorber mounting nut (Upper)	29	2.9	21.0
Rear shock absorber mounting bolt (Lower)	29	2.9	21.0
Rear axle nut	100	10.0	72.5
Seat rail mounting bolt (MB)	23	2.3	16.5
(M10)	50	5.0	36.0
Side-stand bolt	50	5.0	36.0
Side-stand nut	40	4.0	29.0
Center stand bracket bolt	23	2.3	16.5
Center stand nut	29	2.9	21.0

TIGHTENING TORQUE CHART

For other nuts and bolts not listed in the preceding page, refer to this chart:

Bolt Diameter ⌀ (mm)	Conventional or "4" marked bolt			"7" marked bolt		
	N-m	kgf-m	lb-ft	N-m	kgf-m	lb-ft
4	1.5	0.15	1.0	2.3	0.23	1.5
5	3	0.3	2.0	4.5	0.45	3.0
6	5.5	0.55	4.0	10	1.0	7.0
8	13	1.3	9.5	23	2.3	16.5
10	29	2.9	21.0	50	5.0	36.0
12	45	4.5	32.5	85	8.5	61.5
14	65	6.5	47.0	135	13.5	97.5
16	105	10.5	76.0	210	21.0	152.0
18	160	16.0	115.5	240	24.0	173.5



Conventional bolt

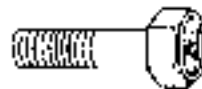

"4" marked bolt



"7" marked bolt

SERVICE DATA

VALVE + GUIDE

Unit: mm (in)

ITEM		STANDARD	LIMIT
Valve diam.	IN.	29.5 (1.16)	—
	EX.	25.0 (0.98)	—
Tappet clearance (when cold)	IN.	0.10 - 0.20 (0.0039 - 0.0079)	—
	EX.	0.20 - 0.30 (0.0079 - 0.0118)	—
Valve guide to valve stem clearance	IN.	0.010 - 0.040 (0.0004 - 0.0016)	—
	EX.	0.030 - 0.060 (0.0012 - 0.0024)	—
Valve guide I.D.	IN. & EX.	4.500 - 4.515 (0.1772 - 0.1778)	—
Valve stem O.D.	IN.	4.475 - 4.490 (0.1762 - 0.1768)	—
	EX.	4.455 - 4.470 (0.1754 - 0.1760)	—
Valve stem deflection	IN. & EX.	—	0.35 (0.014)
Valve stem runout	IN. & EX.	—	0.05 (0.002)
Valve head thickness	IN. & EX.	—	0.5 (0.02)
Valve seat width	IN. & EX.	0.9 - 1.1 (0.035 - 0.043)	—
Valve head radial runout	IN. & EX.	—	0.03 (0.001)
Valve spring free length (IN. & EX.)	IN. & EX.	—	40.6 (1.60)
Valve spring tension (IN. & EX.)	IN. & EX.	136 - 156 N (13.6 - 15.6 kgf, 30.0 - 34.4 lbs) at length 33.4 mm (1.31 in)	—

CAMSHAFT + CYLINDER HEAD

Unit: mm (in)

ITEM		STANDARD	LIMIT
Cam height	IN.	35.38 - 35.43 (1.393 - 1.395)	35.10 (1.382)
	EX.	33.98 - 34.03 (1.338 - 1.340)	33.70 (1.327)
Camshaft journal oil clearance	IN. & EX.	0.037 - 0.066 (0.0013 - 0.0026)	0.150 (0.0059)
Camshaft journal holder I.D.	IN. & EX.	24.012 - 24.025 (0.9454 - 0.9459)	—
Camshaft journal O.D.	IN. & EX.	23.959 - 23.980 (0.9433 - 0.9441)	—
Camshaft round	IN. & EX.		0.10 (0.004)
Cam chain pin (at arrow "3")		15th pin	—
Cylinder head distortion		—	0.10 (0.004)

CYLINDER + PISTON + PISTON RING

Unit: mm (in)

ITEM		STANDARD	LIMIT
Compression pressure		1 500 - 1 900 kPa (15.0 - 19.0 kgf/cm ² , 213 - 270 psi)	1 200 kPa (12 kgf/cm ² , 171 psi)
Compression pressure difference		—	200 kPa (2.0 kgf/cm ² , 29 psi)
Piston to cylinder clearance		0.045 - 0.055 (0.0018 - 0.0022)	0.120 (0.0047)
Cylinder bore		75.500 - 75.515 (2.9724 - 2.9730)	75.585 (2.9758)
Piston diam.		75.450 - 75.465 (2.9705 - 2.9711) Measure at 15 mm (0.6 in) from the skirt end.	75.380 (2.9677)
Cylinder distortion			0.10 (0.004)
Piston ring free end gap	1st R	Approx. 11.6 (0.46)	9.3 (0.37)
	2nd RN	Approx. 8.6 (0.34)	8.9 (0.27)
Piston ring end gap	1st	0.20 - 0.30 (0.008 - 0.012)	0.50 (0.020)
	2nd	0.20 - 0.30 (0.008 - 0.012)	0.50 (0.020)
Piston ring to groove clearance	1st	—	0.180 (0.007)
	2nd	—	0.150 (0.006)
Piston ring groove width	1st	1.01 - 1.03 (0.040 - 0.041)	—
	2nd	1.01 - 1.03 (0.040 - 0.041)	—
	Oil	2.01 - 2.03 (0.079 - 0.080)	—

ITEM		STANDARD	LIMIT
Piston ring thickness	1st	0.97 - 0.99 (0.038 - 0.039)	-
	2nd	0.97 - 0.98 (0.038 - 0.039)	-
Piston pin bore		16.002 - 16.008 (0.6300 - 0.6302)	16.030 (0.6311)
Piston pin O.D.		15.995 - 16.003 (0.6297 - 0.6299)	15.980 (0.6291)

CONROD + CRANKSHAFT

Unit: mm (in)

ITEM		STANDARD	LIMIT
Conrod small end I.D.		16.010 - 16.018 (0.6303 - 0.6306)	16.040 (0.6315)
Conrod big end side clearance		0.10 - 0.20 (0.004 - 0.008)	0.30 (0.012)
Conrod big end width		19.950 - 20.000 (0.7854 - 0.7874)	-
Crank pin width		20.100 - 20.150 (0.7913 - 0.7933)	-
Conrod big end oil clearance		0.032 - 0.058 (0.0013 - 0.0022)	0.080 (0.0031)
Crank pin O.D.		44.976 - 45.000 (1.7707 - 1.7717)	-
Crankshaft journal oil clearance		0.018 - 0.045 (0.0007 - 0.0018)	0.080 (0.0031)
Crankshaft journal O.D.		47.985 - 48.000 (1.8892 - 1.8898)	-
Crankshaft thrust bearing thickness		2.025 - 2.175 (0.0797 - 0.0856)	-
Crankshaft thrust clearance		0.10 - 0.15 (0.0039 - 0.0059)	-
Crankshaft runout		-	0.05 (0.002)

OIL PUMP

ITEM	STANDARD	LIMIT
Oil pressure (at 60°C, 140°F)	Above 350 kPa (3.5 kgf/cm ²) Below 550 kPa (5.5 kgf/cm ²) at 3 000 r/min.	-

CLUTCH

Unit: mm (in)

ITEM	STANDARD	LIMIT
Drive plate thickness	2.92 - 3.08 (0.115 - 0.121)	2.62 (0.103)
Drive plate claw width	13.85 - 13.96 (0.545 - 0.550)	13.05 (0.514)
Driven plate No.2 thickness	2.58 - 2.42 (0.102 - 0.095)	2.27 (0.089)
Driven plate No.1 distortion	-	0.10 (0.004)
Clutch spring free length	13.9 (0.547)	13.2 (0.520)
Clutch engagement	1 500 - 2 100 r/min.	-
Clutch lock-up	3 200 - 3 800 r/min.	-

INJECTOR + FUEL PUMP + FUEL PRESSURE REGULATOR

ITEM	SPECIFICATION	NOTE
Injector resistance	11 - 13 Ω at 20 °C (68 °F)	
Fuel pump discharge amount	More than 0.9 L (0.95/0.79 US/Imp qt) For 30 sec, at 300 kPa (3.0 kgf/cm ² , 43 psi)	
Fuel pressure regulator operating set pressure	Approx. 300 kPa (3.0 kgf/cm ² , 43 psi)	

F/ICVT-SENSORS

ITEM	SPECIFICATION	NOTE
GMP sensor resistance	0.9 - 1.7 k Ω	
GMP sensor peak voltage	More than 0.5 V (When cranking)	⊕: B/Y, ⊖: Br
CKP sensor resistance	150 - 300 Ω	
CKP sensor peak voltage	More than 2.0 V (When cranking)	⊕: Bl, ⊖: G
IAP sensor input voltage	4.5 - 5.5 V	
IAP sensor output voltage	Approx. 2.0 V at idle speed	
TP sensor input voltage	4.5 - 5.5 V	
TP sensor resistance	Closed	Approx. 1.1 k Ω
	Opened	Approx. 4.2 k Ω
TP sensor output voltage	Closed	Approx. 1.1 V
	Opened	Approx. 4.3 V
ECT sensor input voltage	4.5 - 5.5 V	
ECT sensor resistance	Approx. 2.45 k Ω at 20 °C (68 °F)	
IAT sensor input voltage	4.5 - 5.5 V	
IAT sensor resistance	Approx. 2.45 k Ω at 20 °C (68 °F)	
AP sensor input voltage	4.5 - 5.5 V	
AP sensor output voltage	Approx. 3.6 V at 760 mmHg (100 kPa)	
TO sensor resistance	19.1 - 19.7 k Ω	
TO sensor output voltage	Normal	Less than 1.4 V
	Leaning	Less than 3.7 V
Injector voltage	Battery voltage	
Ignition coil primary peak voltage	More than 80 V (When cranking)	#1 ⊕: W/Bl, ⊖: Ground #2 ⊕: B/Y, ⊖: Ground
H ₂ O ₂ sensor resistance	4 - 5 Ω at 23 °C (73.4 °F)	
H ₂ O ₂ sensor output voltage	Idle speed	Less than 0.4 V
	3 000 r/min.	More than 0.6 V
PAIR solenoid valve resistance	20 - 24 Ω at 20 °C (68 °F)	
CVT primary pulley position sensor	Compressed	1.9 - 2.3 k Ω
	Extended	0.2 - 1.0 k Ω
CVT primary pulley position sensor output voltage	1 st : Idle speed	Approx. 3.3 V
	3 rd : 3 000 r/min.	Approx. 1.3 V
	5 th : 3 000 r/min.	Approx. 0.5 V
CVT secondary pulley revolution sensor resistance	400 - 600 Ω	
CVT secondary pulley revolution sensor peak voltage	More than 5V at idle speed	⊕: Y, ⊖: W

THROTTLE BODY

ITEM	SPECIFICATION
ID No.	100D
Bore size	32 mm
Fast idle r/min.	1 800 - 1800 r/min.
Idle r/min.	1 200 ± 100 r/min.
Synchronizing screw opening	1½ turns out
IAC valve resistance	Approx. 4 Ω at 20 - 24 °C (68 - 75 °F)
Throttle cable play	2.0 - 4.0 mm (0.08 - 0.16 in)

THERMOSTAT + RADIATOR + FAN + COOLANT

ITEM	STANDARD/SPECIFICATION	LIMIT	
Thermostat valve opening temperature	Approx. 88 °C (190 °F)	—	
Thermostat valve lift	Over: 0.0 mm (0.3 in) at 100°C (212 °F)	—	
Engine coolant temperature sensor resistance	20 °C (68 °F)	Approx. 2.45 kΩ	—
	50 °C (122 °F)	Approx. 0.811 kΩ	—
	80 °C (176 °F)	Approx. 0.318 kΩ	—
	110 °C (230 °F)	Approx. 0.142 kΩ	—
Radiator cap valve opening pressure	110 kPa (1.1 kg/cm ²)	—	
Electric fan thermo-switch operating temperature	ON	93 - 103 °C	—
	OFF	87 - 97 °C	—
Engine coolant type	Use an anti-freeze/coolant compatible with aluminum radiator, mixed with distilled water only, at the ratio of 50:50.	—	
Engine coolant including reserve	Reverse tank side	Approx. 250 ml	—
	Engine side	Approx. 1 050 ml	—

ELECTRICAL

Unit: mm (in)

ITEM	STD/SPEC.	NOTE	
Firing order	1-2		
Spark plug	Type	NGK: CR8E DENSO: U24ESR-N	
	Gap	0.7 - 0.8 (0.028 - 0.031)	
Spark performance	Over 8.0 mm (0.3) at 1 atm.		
CKP sensor peak voltage	More than 2.0 V	⊕: Bl, ⊖: G	
Ignition coil resistance	Primary	0.8 - 2.5 Ω	
	Secondary	8 - 18 kΩ	
Ignition coil primary peak voltage	More than 80 V	#1 ⊕: W/Bl, ⊖: Ground #2 ⊕: B/Y, ⊖: Ground	
Generator coil resistance	CKP sensor	150 - 300 Ω	G Bl
	Charging	0.1 - 1.0 Ω	Y - Y

ITEM	STD/SPEC.		NOTE
Generator no-load voltage (When cold)	More than 50 V at 5 000 r/min.		
Generator Max. output	Approx. 500 W at 5 000 r/min.		
Regulated voltage	14.0 - 15.5 V at 5 000 r/min.		
Starter relay resistance	3 - 6 Ω		
Battery	Type designation	FTX14-BS	
	Capacity	12 V 43.2 kC (12 Ah)/10 HR	
Fuze size	Head-light	HI	15 A
		LO	15 A
	Fuel pump	10 A	
	Ignition	15 A	
	Turn signal	15 A	
	Fan motor	10 A	
	Main	40 A	
	CVT	40 A	

WATTAGE

Unit: W

ITEM		STD/SPEC.	
		E-02, 19	E-03, 24, 28, 33
Headlight	HI	60 + 55	60 × 2
	LO	55	55 × 2
Parking or position light		5 × 2	
Brake light/Tailight		21/5 × 2	←
Turn signal light		21	←
License light		5	←
Instrument panel light		1.4 × 2	←
Engine coolant temp. indicator light		1.4	←
F1 indicator light		1.4	←
Engine oil pressure indicator light		1.4 × 2	←
Brake lock indicator light		1.4	←
High beam indicator light		1.4	←
Turn signal indicator light		1.4 × 2	←
Power mode indicator light		1.4	←
Drive indicator light		1.4	←
Gear position indicator light		1.4 × 5	←
Trunk light		5	←

BRAKE + WHEEL

Unit: mm (in)

ITEM	STANDARD		LIMIT
Brake disc thickness	Front	4.5 ± 0.2 (0.177 ± 0.008)	4.0 (0.16)
	Rear	5.5 ± 0.2 (0.217 ± 0.008)	5.0 (0.20)
Brake disc runout	—		0.30 (0.012)
Master cylinder bore	Front	12.700 - 12.743 (0.5000 - 0.5017)	—
	Rear	12.700 - 12.743 (0.5000 - 0.5017)	—
Master cylinder piston diameter	Front	12.657 - 12.684 (0.4983 - 0.4994)	—
	Rear	12.657 - 12.684 (0.4983 - 0.4994)	—
Brake caliper cylinder bore	Front	25.400 - 25.450 (1.0000 - 1.0020)	—
	Rear	27.000 - 27.050 (1.0630 - 1.0650)	—
Brake caliper piston diameter	Front	25.918 - 25.968 (0.9968 - 0.9987)	—
	Rear	26.918 - 26.968 (1.0598 - 1.0617)	—
Brake fluid type	DOT4		—
Wheel rim runout	Axial	—	2.0 (0.08)
	Radial	—	2.0 (0.08)
Wheel axle runout	Front	—	0.25 (0.010)
	Rear	—	0.25 (0.010)
Wheel rim size	Front	15 M/C × MT3.50	—
	Rear	14 M/C × MT4.50	—

SUSPENSION

Unit: mm (in)

ITEM	STANDARD	LIMIT
Front fork stroke	105 (4.1)	—
Front fork spring free length	—	341 (13.4)
Front fork oil type	SUZUKI FORK OIL G-10 (#10) or an equivalent fork oil	—
Front fork oil capacity (each leg)	482 ml (16.29/16.97 US/Imp oz)	—
Front fork oil level	129 (5.09)	—
Rear wheel travel	100 (3.9)	—
Rear shock absorber spring adjuster	2nd	—

TIRE

ITEM		STANDARD		LIMIT
Cold inflation tire pressure	Solo riding	Front	225 kPa (2.25 kgf/cm ² , 33 psi)	—
		Rear	250 kPa (2.50 kgf/cm ² , 36 psi)	—
	Dual riding	Front	225 kPa (2.25 kgf/cm ² , 33 psi)	—
		Rear	280 kPa (2.80 kgf/cm ² , 41 psi)	—
Tire size	Front	120/70R15M/C 55H	—	
	Rear	160/60H14M/C 65H	—	
Tire type	Front	BRIDGESTONE TH01F	—	
	Rear	BRIDGESTONE TH01R	—	
Tire tread depth (Recommended depth)	Front	—	1.6 mm (0.06 in)	
	Rear	—	2.0 mm (0.08 in)	

FUEL + OIL

ITEM	SPECIFICATION	NOTE
Fuel type	Use only unleaded gasoline of at least 87 pump octane (87 th) or 91 octane or higher rated by the research method. Gasoline containing MTBE (Methyl Tertiary Butyl Ether), less than 10 % ethanol, or less than 5 % methanol with appropriate cosolvents and corrosion inhibitor is permissible. Gasoline used should be graded 91 octane or higher. An unleaded gasoline is recommended.	E-03, 26, 33 The others
Fuel tank capacity	Including reserve	15.0 L (4.0/3.9 US/imp gal)
	Fuel meter mark flickering	Approx. 3.0 L (0.79/0.66 US/imp gal)
	Fuel meter mark and LCD flickering	Approx. 1.5 L (0.40/0.33 US/imp gal)
Engine oil and transmission oil type	SAE 10W-40, API SF or SG	
Engine oil capacity	Oil change	2.8 L (2.7/2.3 US/imp qt)
	Filter change	2.9 L (3.1/2.6 US/imp qt)
	Overhaul	3.4 L (3.6/3.0 US/imp qt)
Transmission oil capacity	Oil change	360 ml (12.2/12.7 US/imp oz)
	Overhaul	400 ml (13.5/14.1 US/imp oz)
Final gear oil type	Hypoid gear oil SAE #90 API grade GL-5	
Final gear oil capacity	Oil change	300 ml (10.1/10.6 US/imp oz)
	Overhaul	430 ml (14.5/15.1 US/imp oz)

EMISSION CONTROL INFORMATION

CONTENTS

EMISSION CONTROL SYSTEMS	12- 2
FUEL INJECTION SYSTEM	12- 2
CRANKCASE EMISSION CONTROL SYSTEM	12- 3
EXHAUST EMISSION CONTROL SYSTEM (PAIR SYSTEM) ..	12- 4
NOISE EMISSION CONTROL SYSTEM	12- 5
PAIR (AIR SUPPLY) SYSTEM INSPECTION	12- 6
HOSE	12- 6
PAIR REED VALVE	12- 6
PAIR CONTROL SOLENOID VALVE	12- 6
PAIR (AIR SUPPLY) SYSTEM HOSE ROUTING	12- 8
HEATED OXGEN SENSOR (HO2S) INSPECTION	12- 9

EMISSION CONTROL SYSTEMS

FUEL INJECTION SYSTEM

AN650 motorcycles are equipped with a fuel injection system for emission level control.

This fuel injection system is precision designed, manufactured and adjusted to comply with the applicable emission limits.

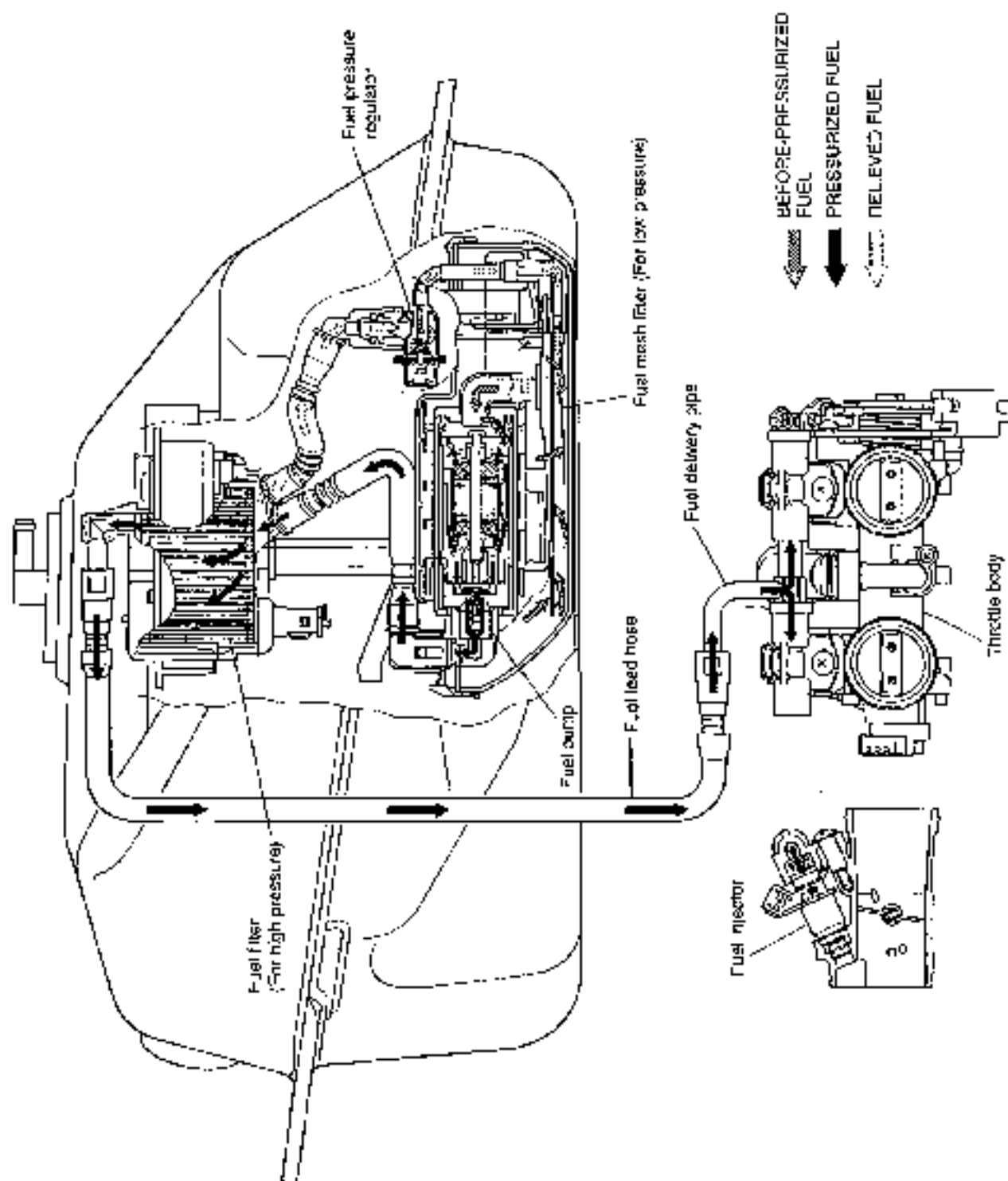

CRANKCASE EMISSION CONTROL SYSTEM

The engine is equipped with a PCV system. Blow-by gas in the engine is constantly drawn into the crankcase, which is returned to the combustion chamber through the PCV (breather) hose, air cleaner and throttle body.

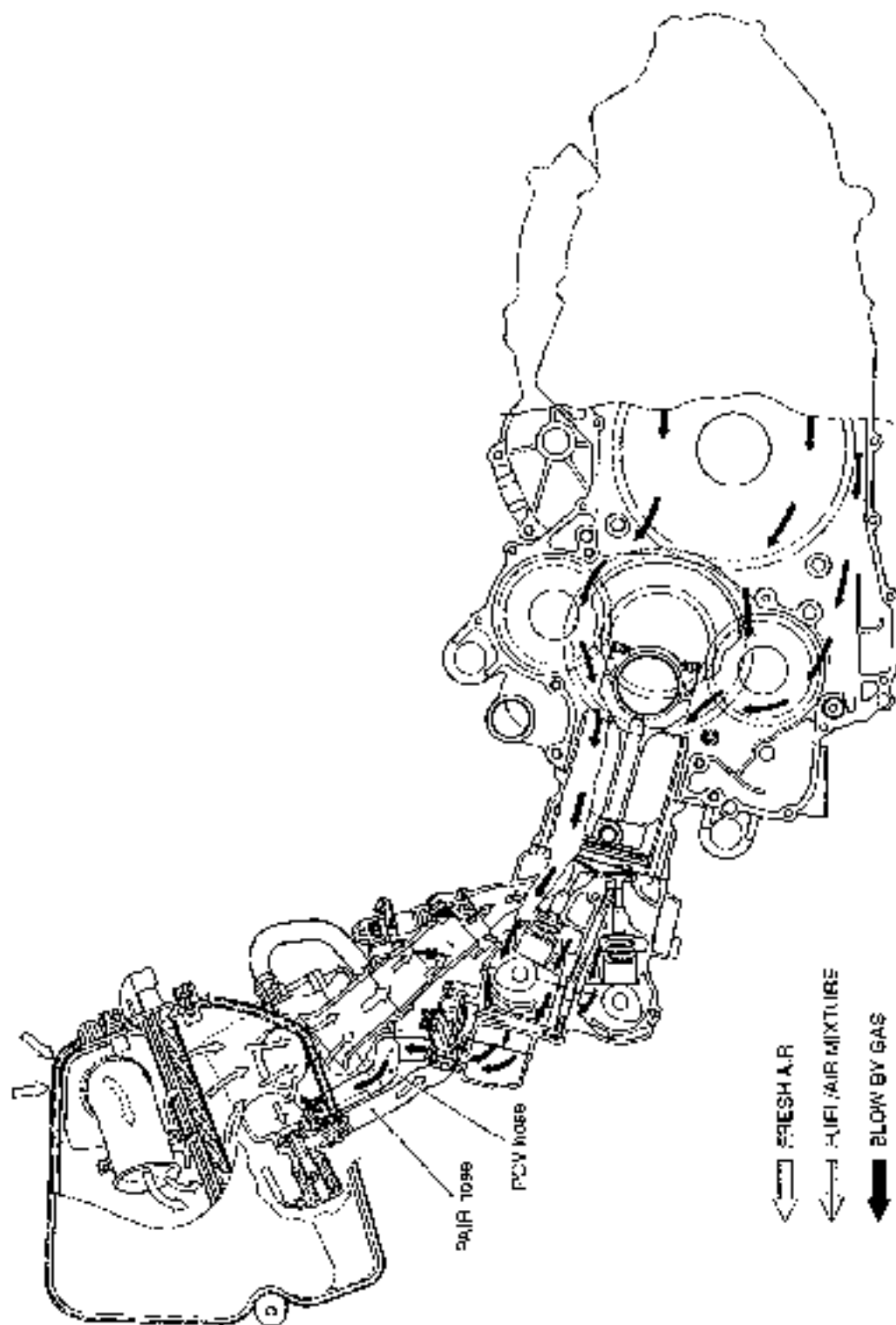

EXHAUST EMISSION CONTROL SYSTEM (PAIR SYSTEM)

The exhaust emission control system is composed of the PAIR system and THREE-WAY CATALYST system. The fresh air is drawn into the exhaust port with the PAIR solenoid valve and PAIR reed valve. The PAIR solenoid valve is operated by the ECM, and the fresh air flow is controlled according to the TPS, ECTS, IATS, IAPS and CKPS.

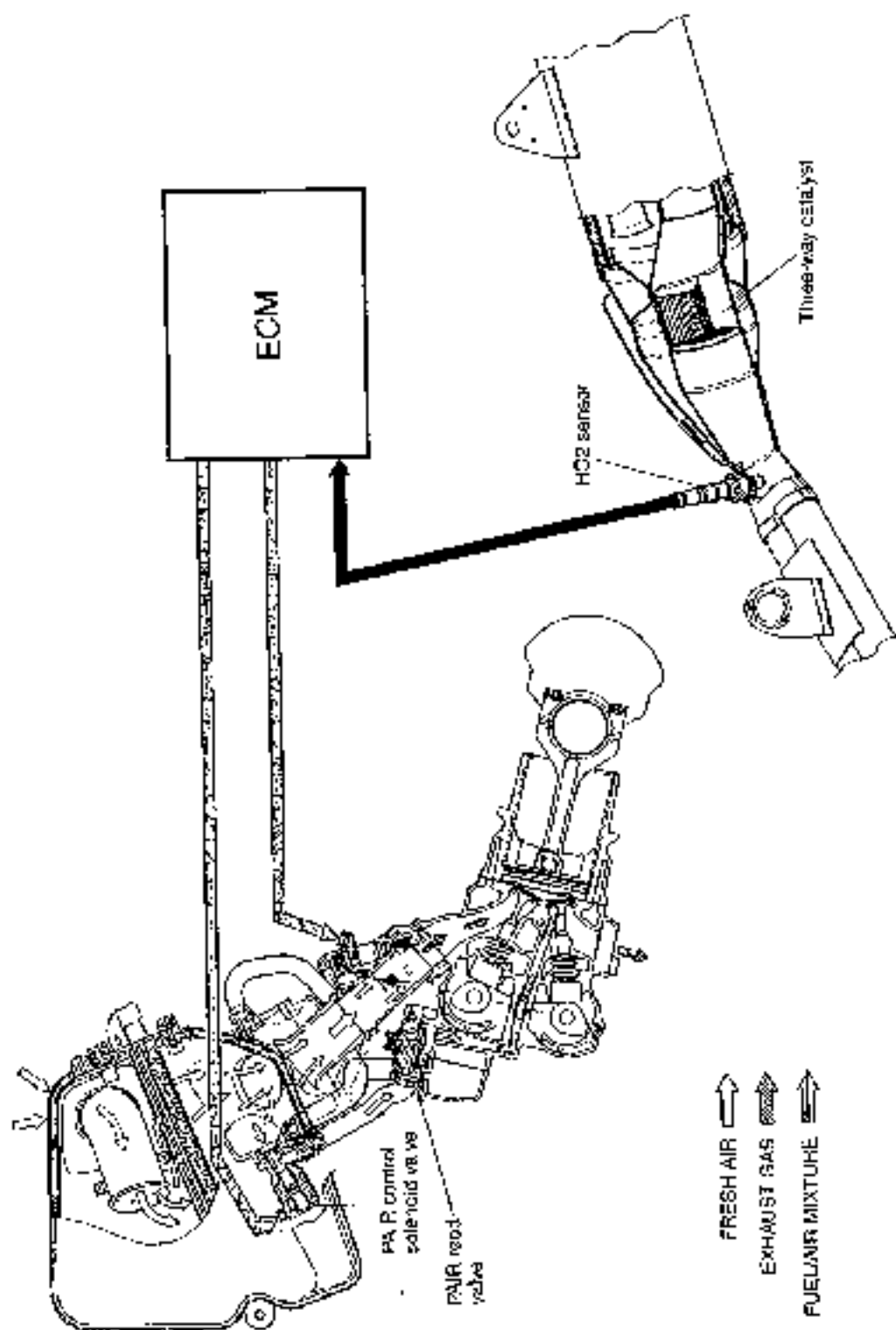

NOISE EMISSION CONTROL SYSTEM

TAMPERING WITH THE NOISE CONTROL SYSTEM PROHIBITED: Local law prohibits the following acts or the causing thereof:

1. The removal or rendering inoperative by any person, other than for purposes of maintenance, repair or replacement, of any device or element of design incorporated into any new vehicle for the purpose of noise control prior to its sale or delivery to the ultimate purchaser or while it is in use, or
2. The use of the vehicle after such device or element of design has been removed or rendered inoperative by any person.

AMONG THOSE ACTS PRESUMED TO CONSTITUTE TAMPERING ARE THE ACTS LISTED BELOW:

- Removing or puncturing the muffler, baffles, header pipes, screen type spark arrester (if equipped) or any other component which conducts exhaust gases.
- Removing or puncturing the air cleaner case, air cleaner cover, baffles or any other component which conducts intake air.
- Replacing the exhaust system or muffler with a system or muffler not marked with the same model specific code as the code listed on the Motorcycle Noise Emission Control Information label.

PAIR (AIR SUPPLY) SYSTEM INSPECTION

HOSE

- Remove the front box. (CJ7-9-18)
- Inspect the hose for wear or damage.
- Inspect that the hose is securely connected.



PAIR REED VALVE

- Remove the air chamber. (CJ7-7-16)
- Remove the PAIR reed valve cover.

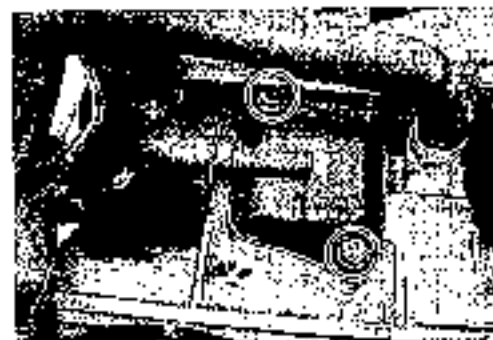

- Inspect the reed valve for the carbon deposit.
- If the carbon deposit is found in the reed valve, replace the PAIR reed valve with a new one.
- Installation is in the reverse order of removal.



PAIR CONTROL SOLENOID VALVE

- Disconnect the PAIR control solenoid valve lead wire coupler.
- Disconnect the PAIR hose.
- Remove the PAIR control solenoid valve.



- Check that air flows through the air inlet port to the air outlet port.
- If air does not flow out, replace the PAIR control solenoid valve with a new one.

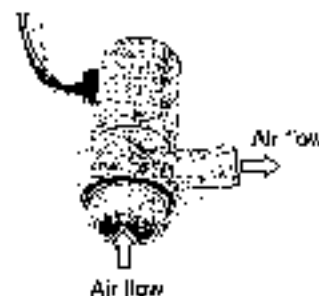

- Connect the 12 V battery to the PAIR control solenoid valve terminals and check the air flow.
- If air does not flow out, the solenoid valve is in normal condition.

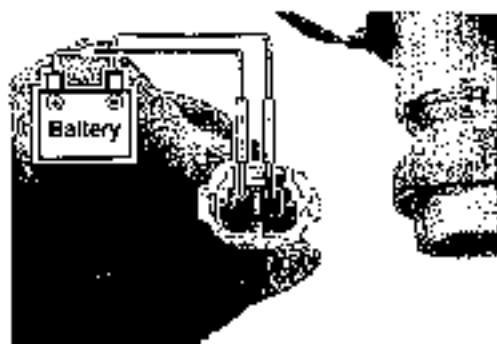

- Check the resistance between the terminals of the PAIR control solenoid valve.

DATA Resistance: 20 – 24 Ω (at 20 °C/68 °F)

MSD 09900-25008: Multi circuit tester set

(M) Tester knob indication: Resistance (Ω)

If the resistance is not within the standard range, replace the PAIR control solenoid valve with a new one.

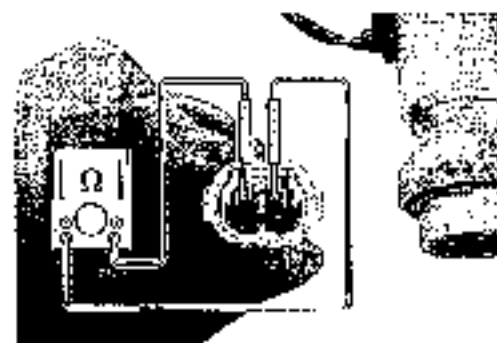

- Installation is in the reverse order of removal
- Connect the PAIR control solenoid valve lead wire coupler securely.

PAIR (AIR SUPPLY) SYSTEM HOSE ROUTING

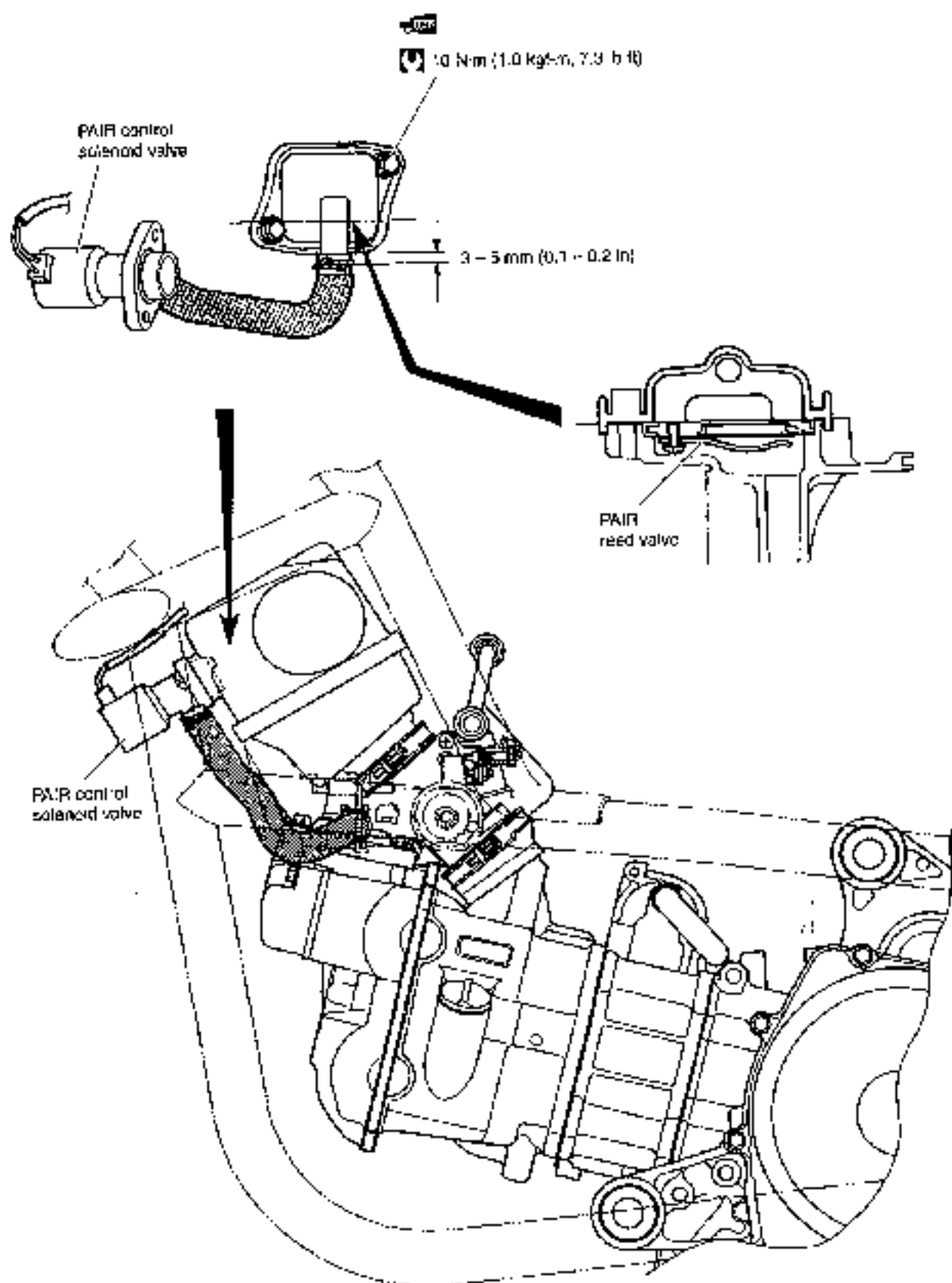

HEATED OXGEN SENSOR (HO2S) INSPECTION

- Remove the foot board. (C-9-16)
- Disconnect the HO2 sensor lead wire coupler.
- Remove the HO2 sensor unit.

⚠ WARNING

Do not remove the HO2 sensor while it is hot.

⚠ CAUTION

Be careful not to expose it to excessive shock.
Do not use an impact wrench while removing or installing the HO2 sensor unit.
Be careful not to twist or damage the sensor lead wire.

- Inspect the HO2 sensor and its circuit referring to flow table of the malfunction code (C44).
- Disconnect the HO2 sensor coupler.
- Check the resistance between the terminals (white - white) of the HO2 sensor.

DATA Resistance: 4 - 5 Ω (at 23 °C/73.4 °F)

DCR 09900-25006: Multi circuit tester set

Tester knob indication: Resistance (Ω)

If the resistance is not within the standard range, replace the HO2 sensor with a new one.

NOTE:

- Temperature of the sensor affects resistance value largely.
- Make sure that the sensor heater is at correct temperature.
- Connect the HO2 sensor coupler securely.

- Installation is in the reverse order of removal.

⚠ CAUTION

Do not apply oil or other materials to the sensor air hole.

- Tighten the sensor unit to the specified torque.

U HO2 SENSOR: 47.5 N·m (4.75 kgf·m, 34.3 lb·ft)

- Route the HO2 sensor lead wire into the frame
- Connect the HO2 sensor coupler.



WIRING DIAGRAM

E-02, 19

- HL : HIGH BEAM INDICATOR LIGHT
- OL : OIL PRESSURE INDICATOR LIGHT
- H : HORN
- DLK : BRAKE LOCK INDICATOR LIGHT
- TR : TURN SIGNAL INDICATOR LIGHT (R)
- L : ILLUMINATION
- TL : TURN SIGNAL INDICATOR LIGHT (L)
- WT : WARNING LIGHT AND SIGNAL INDICATOR LIGHT
- PT : PARK POSITION INDICATOR (R-L)
- D : DRIVE SHAFT INDICATOR
- PM : POWER MODE INDICATOR

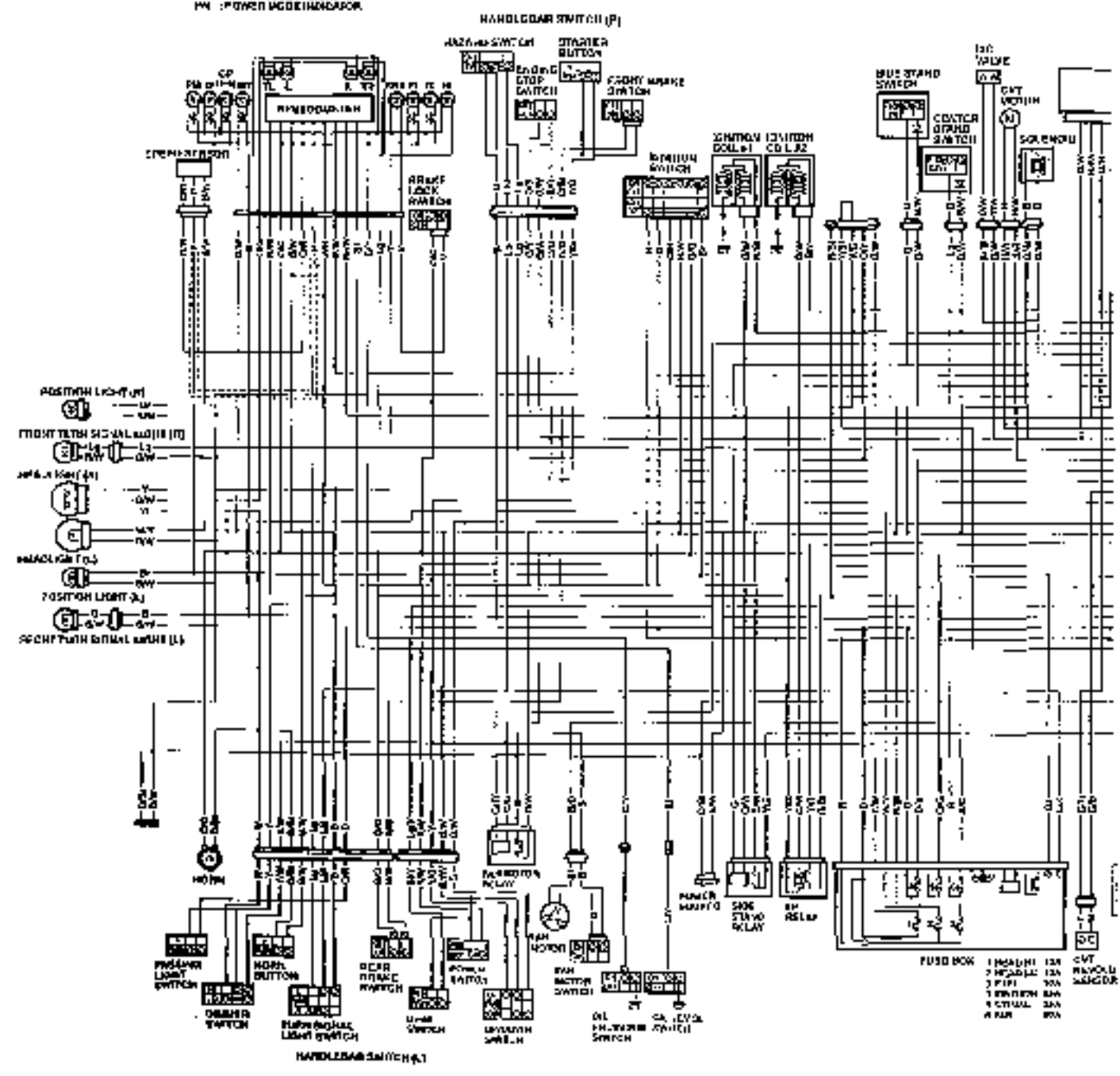

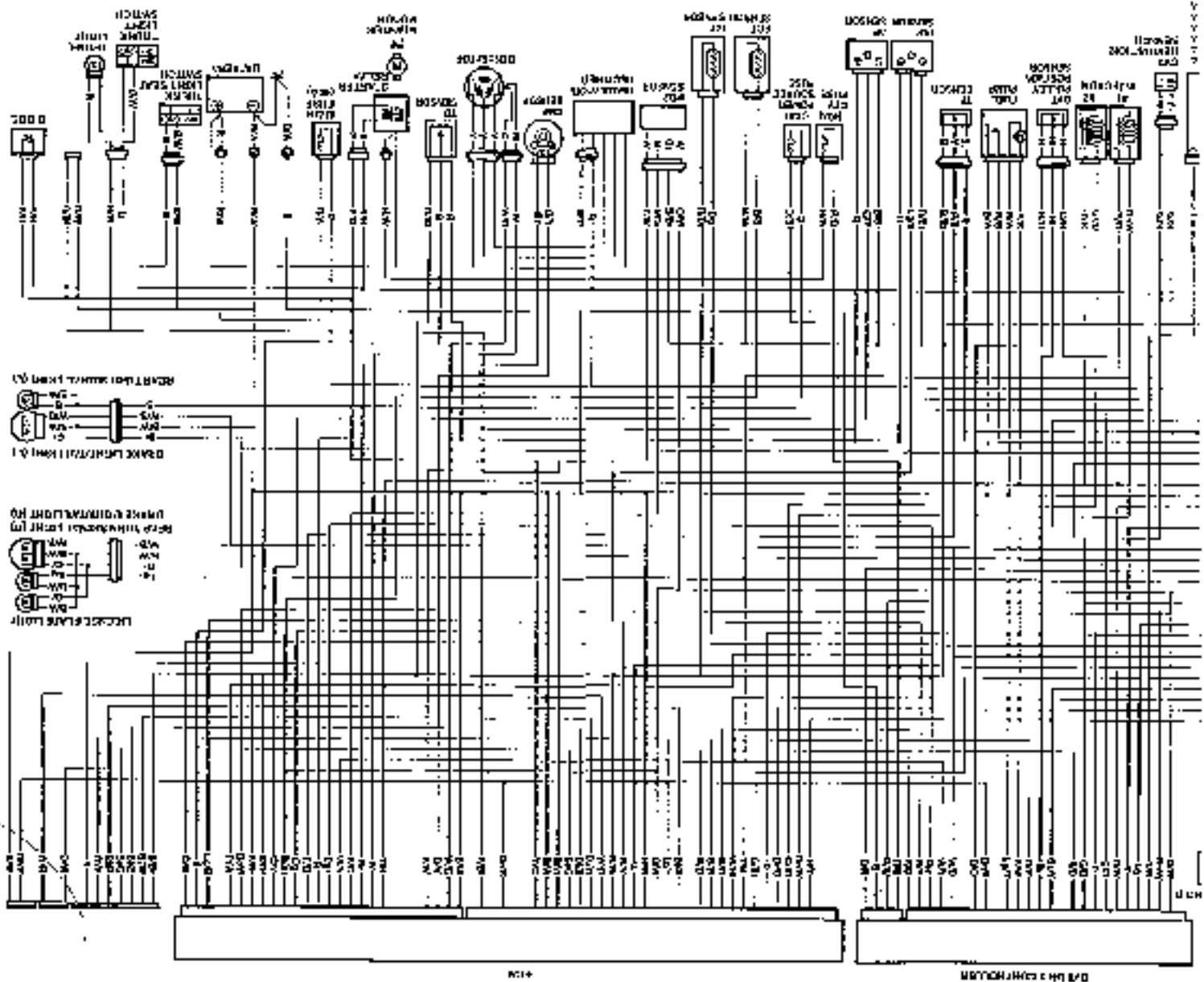

W14

W14 (REV. 11/78)

CFT -HYD CONTROLLER

174

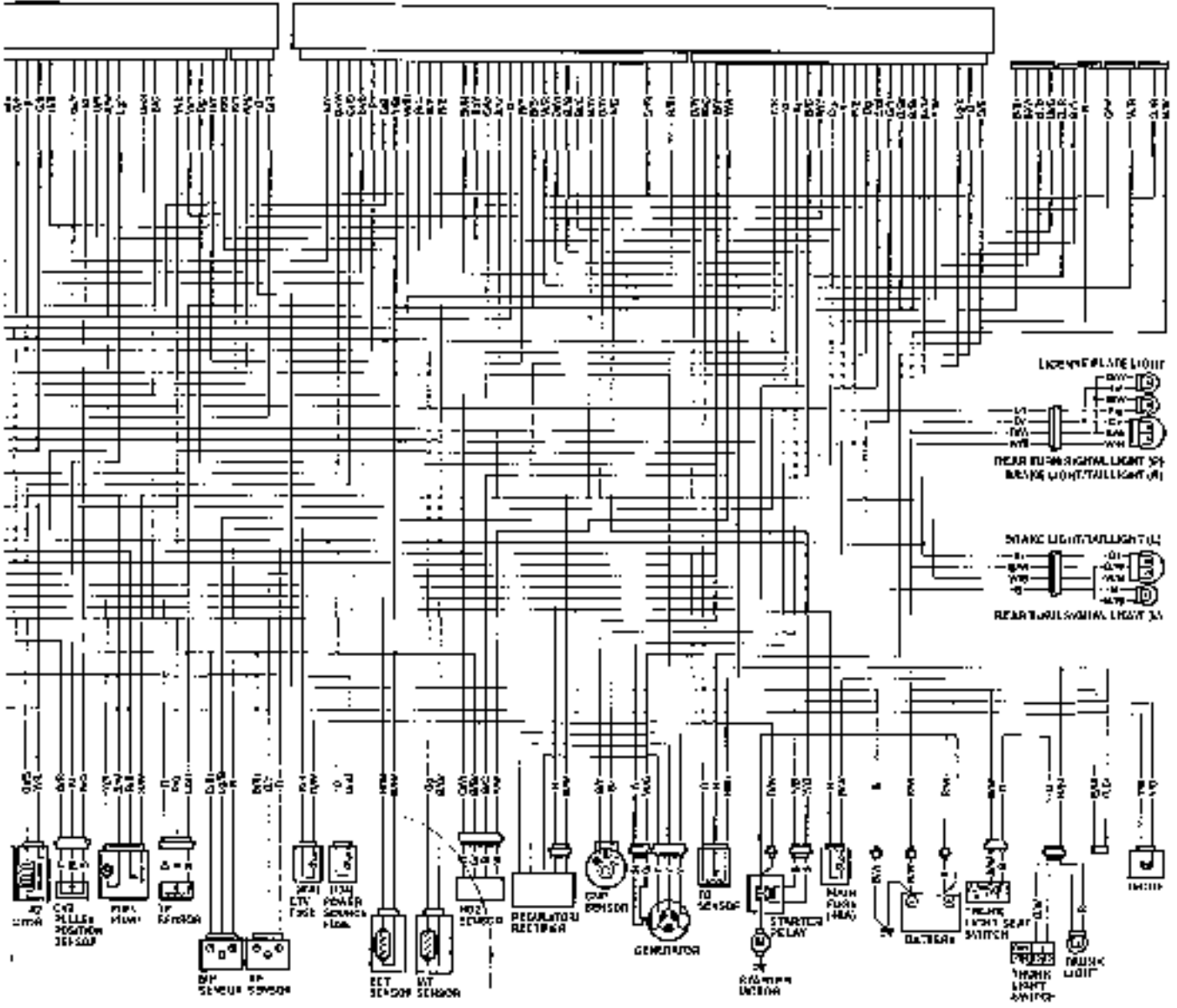

AN650L

- HL : HIGH BEAM HEADLIGHT
- LL : LOW BEAM HEADLIGHT
- PL : P FUSE
- HLR : HIGH BEAM HEADLIGHT RELAY
- TL : TURN SIGNAL INDICATOR LIGHT (R)
- L : LAMP
- TLR : TURN SIGNAL INDICATOR LIGHT (L)
- WFL : FRONT WHEEL LIGHT INDICATOR LIGHT
- WR : REAR WHEEL LIGHT INDICATOR LIGHT
- P : POWER INDICATOR
- PM : POWER MODE INDICATOR

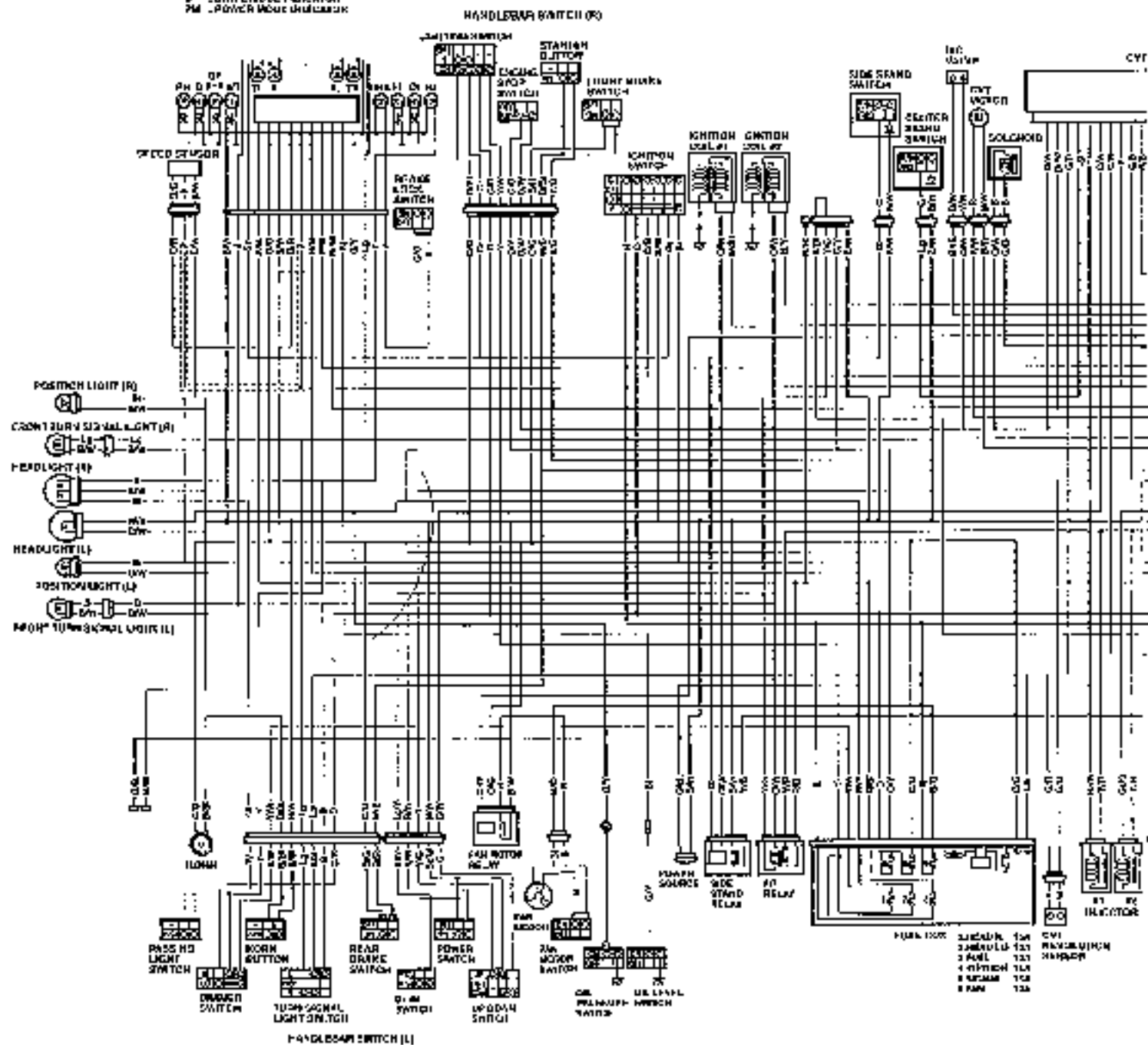

WIRE NO.	STARTER	END	CVT MAXIMUM
1	3	121	HANDLER
2	4	121	
3	5	121	
4	6	121	
5	7	121	
6	8	121	
7	9	121	

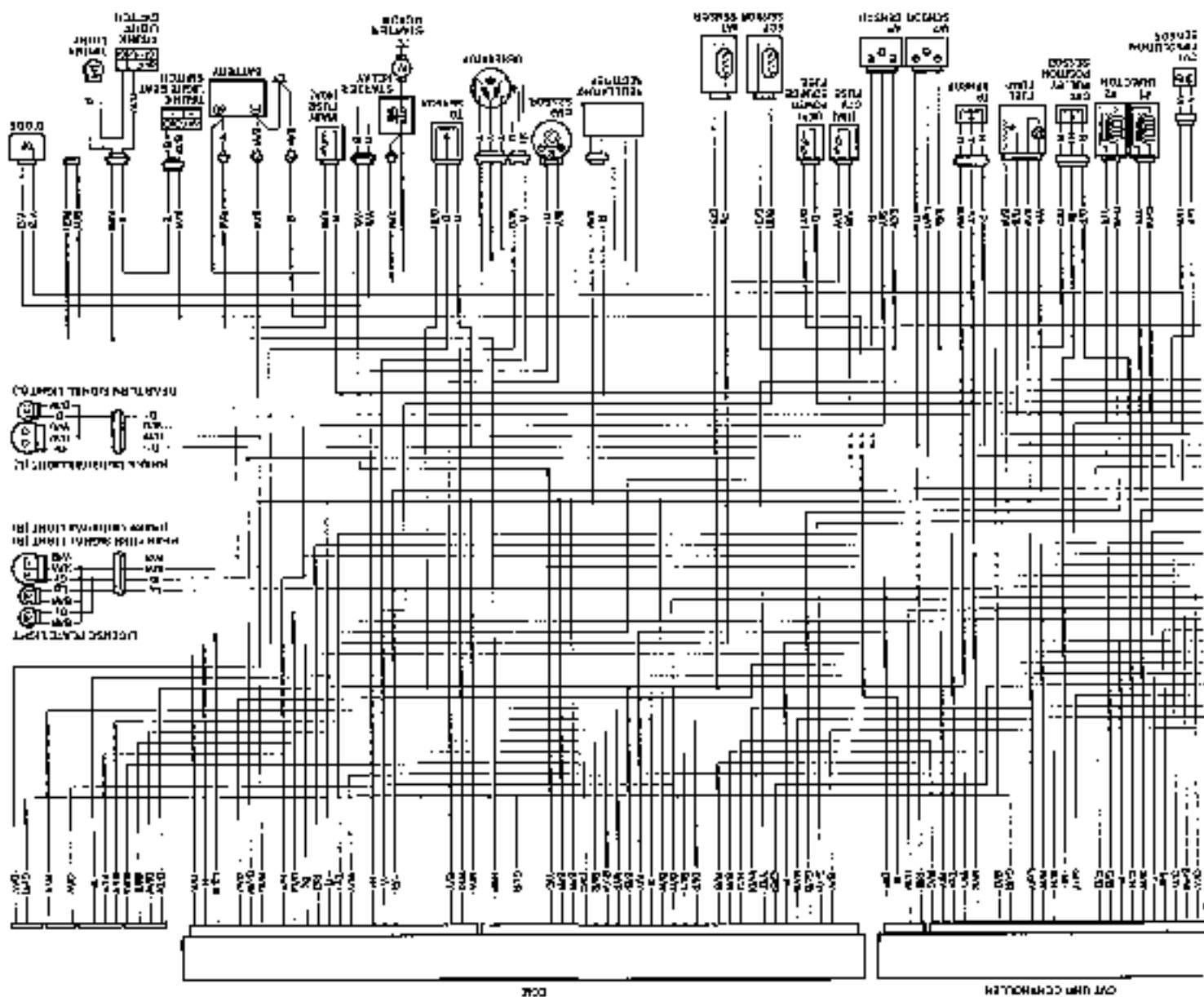

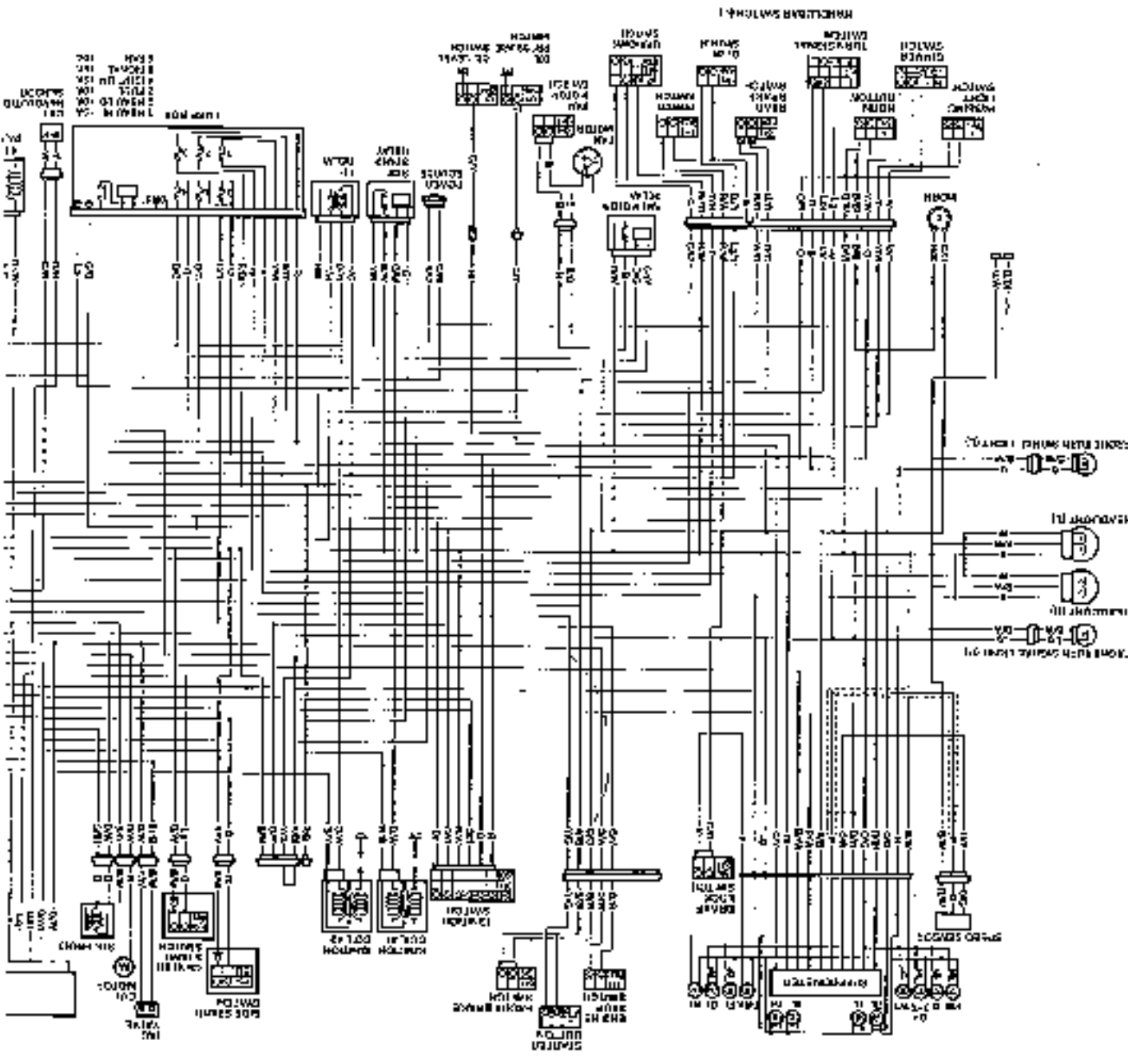

- IR - RED SIGNAL INDICATOR LIGHT
- OR - ORANGE SIGNAL INDICATOR LIGHT
- Y - YELLOW
- TR - TURN SIGNAL INDICATOR LIGHT (L)
- TR - TURN SIGNAL INDICATOR LIGHT (R)
- BL - BLUE
- RM - REMOTE LOCK INDICATOR LIGHT
- TR - TURN SIGNAL INDICATOR LIGHT (L)
- TR - TURN SIGNAL INDICATOR LIGHT (R)
- BL - BLUE
- OR - ORANGE SIGNAL INDICATOR LIGHT
- IR - RED SIGNAL INDICATOR LIGHT

HEADLAMP SWITCHING

HANDLAMP SWITCHING

- 1 - HEADLAMP
- 2 - HEADLAMP
- 3 - HEADLAMP
- 4 - HEADLAMP
- 5 - HEADLAMP
- 6 - HEADLAMP
- 7 - HEADLAMP
- 8 - HEADLAMP
- 9 - HEADLAMP
- 10 - HEADLAMP
- 11 - HEADLAMP
- 12 - HEADLAMP
- 13 - HEADLAMP
- 14 - HEADLAMP
- 15 - HEADLAMP
- 16 - HEADLAMP
- 17 - HEADLAMP
- 18 - HEADLAMP
- 19 - HEADLAMP
- 20 - HEADLAMP
- 21 - HEADLAMP
- 22 - HEADLAMP
- 23 - HEADLAMP
- 24 - HEADLAMP
- 25 - HEADLAMP
- 26 - HEADLAMP
- 27 - HEADLAMP
- 28 - HEADLAMP
- 29 - HEADLAMP
- 30 - HEADLAMP
- 31 - HEADLAMP
- 32 - HEADLAMP
- 33 - HEADLAMP
- 34 - HEADLAMP
- 35 - HEADLAMP
- 36 - HEADLAMP
- 37 - HEADLAMP
- 38 - HEADLAMP
- 39 - HEADLAMP
- 40 - HEADLAMP
- 41 - HEADLAMP
- 42 - HEADLAMP
- 43 - HEADLAMP
- 44 - HEADLAMP
- 45 - HEADLAMP
- 46 - HEADLAMP
- 47 - HEADLAMP
- 48 - HEADLAMP
- 49 - HEADLAMP
- 50 - HEADLAMP
- 51 - HEADLAMP
- 52 - HEADLAMP
- 53 - HEADLAMP
- 54 - HEADLAMP
- 55 - HEADLAMP
- 56 - HEADLAMP
- 57 - HEADLAMP
- 58 - HEADLAMP
- 59 - HEADLAMP
- 60 - HEADLAMP
- 61 - HEADLAMP
- 62 - HEADLAMP
- 63 - HEADLAMP
- 64 - HEADLAMP
- 65 - HEADLAMP
- 66 - HEADLAMP
- 67 - HEADLAMP
- 68 - HEADLAMP
- 69 - HEADLAMP
- 70 - HEADLAMP
- 71 - HEADLAMP
- 72 - HEADLAMP
- 73 - HEADLAMP
- 74 - HEADLAMP
- 75 - HEADLAMP
- 76 - HEADLAMP
- 77 - HEADLAMP
- 78 - HEADLAMP
- 79 - HEADLAMP
- 80 - HEADLAMP
- 81 - HEADLAMP
- 82 - HEADLAMP
- 83 - HEADLAMP
- 84 - HEADLAMP
- 85 - HEADLAMP
- 86 - HEADLAMP
- 87 - HEADLAMP
- 88 - HEADLAMP
- 89 - HEADLAMP
- 90 - HEADLAMP
- 91 - HEADLAMP
- 92 - HEADLAMP
- 93 - HEADLAMP
- 94 - HEADLAMP
- 95 - HEADLAMP
- 96 - HEADLAMP
- 97 - HEADLAMP
- 98 - HEADLAMP
- 99 - HEADLAMP
- 100 - HEADLAMP

SUZUKI MOTOR CORPORATION

Made in Japan

SUZUKI

AN650

SERVICE MANUAL

SUZUKI

AN650

SERVICE MANUAL