



Motorcycle Art

F4
BRUTALE



MV AGUSTA F4 BRUTALE S

Use and maintenance manual

Information



MV Agusta S.p.A. is committed to a policy of constant improvement; therefore, you may find slight differences between the information provided in this document and the vehicle you purchased. MV Agusta motorcycles are exported in several countries, in which different rules and regulations (concerning both the Highway Code and the homologation procedures) are in force. Relying on your understanding, MV Agusta S.p.A. deems it necessary to reserve the right to change its products and the related documentation at any time and without notice.



Respect and defend natural environment

Everything we do affects the whole planet as well as its resources.

MV Agusta, in order to protect the interests of the community, awakens the Customers and the Technical Assistance operators to use the vehicle and dispose of its replaced parts respecting the laws in force concerning environmental pollution and waste disposal and recycling.

© 2004

This document may not, in whole or in part, be reproduced without prior consent, in writing, from MV Agusta S.p.A.

Part No. 8A00A4902 - Edition No. 1

Printed in September 2004

MV AGUSTA



Use and maintenance manual

F4

BRUTALE

Il presente Manuale di uso e manutenzione è disponibile nelle edizioni in lingua sotto specificate:

This Manual is available in the languages listed below:

Le présent livret d'utilisation et d'entretien est disponible dans les éditions rédigées dans les langues spécifiées ci-dessous:

Die vorliegende Bedienungs- und Wartungsanleitung ist in folgenden Sprachen erhältlich:

Las ediciones del presente manual de uso y mantenimiento están disponibles en los siguientes idiomas:

Codice/Code/Code
Bestell-Nr./Código

Edizione Italiana	<i>Italian Edition</i>	Edition Italienne	<i>Italienische Ausgabe</i>	Edición en Italiano	8000A4902
Edizione Inglese	<i>English Edition</i>	Edition Anglaise	<i>Englische Ausgabe</i>	Edición en Inglés	8A00A4902
Edizione Francese	<i>French Edition</i>	Edition Française	<i>Französische Ausgabe</i>	Edición en Francés	8B00A4902
Edizione Tedesca	<i>German Edition</i>	Edition Allemande	<i>Deutsche Ausgabe</i>	Edición en Alemán	8C00A4902
Edizione Spagnola	<i>Spanish Edition</i>	Edition Espagnole	<i>Spanische Ausgabe</i>	Edición en Español	8D00A4902
Edizione USA	<i>USA Edition</i>	Edition USA	<i>USA Ausgabe</i>	Edición USA	8000A4903

Dear Customer,

We wish to thank you for your preference and congratulate you on purchasing your new F4 Brutale. MV Agusta, thanks to the passionate effort of its technicians, offers to its customers a motorcycle with a new aesthetic design combined with a refined framework: these are the elements which have distinguished every vehicle created by MV Agusta throughout its glorious history.

The result of this effort is an exclusive motorcycle with functional and aesthetic characteristics that place it above the finest motorcycles currently available on the market, making it an exclusive and sought-after item.

In fact, the technologies and solutions applied give to the F4 Brutale unique characteristics common to all the MV Agusta models, strenghtening a design phylosophy that involves continuous research, technological innovation and love for detail. This way, MV Agusta gives to all the bikers who freely live their passion the chance to possess a unique object, which surely represents a strong reference worldwide. This manual has been drawn up with a view to providing you with a clear and practical guide to operating and maintaining your new motorcycle while safeguarding your warranty rights.

For further information, please feel free to contact the MV Agusta Customer Care Service.

Have a good time!

*Claudio Castiglioni
MV Agusta
Chairman*



CONTENTS

<i>chap.</i>	<i>Subject covered</i>	<i>page</i>
1	GENERAL INFORMATION	10
1.1.	Purpose of the manual	10
1.2.	Symbols	11
1.3.	Warranty Booklet and Service Coupons	12
1.4.	Identification data	13
2	SAFETY INFORMATION	22
2.1.	Safety	22
2.1.1.	Note on tampering	22
2.1.2.	Safety rules	23
2.1.3.	Precautions for children	25
2.1.4.	Installing accessories	26
2.1.5.	Vehicle load	27
2.1.6.	Modifications	29
2.1.7.	Competitions	29
2.1.8.	Recommendations for safe riding	30
2.1.9.	Protective clothing	33
2.1.10.	Suggestions against theft	34
2.2.	Safety labels - Location	35
2.3.	Safety - Visual and acoustic signals	39
3	CONTROLS AND INSTRUMENTS	40
3.1.	Location of controls and instruments	40

<i>chap.</i>	<i>Subject covered</i>	<i>page</i>
3.2.	Sidestand	42
3.3.	Handlebar controls, left side	43
3.4.	Handlebar controls, right side	45
3.5.	Ignition switch and steering lock	46
3.6.	Gear lever	52
3.7.	Instruments and warning lights	53
3.7.1.	Warning lights	54
3.7.2.	Multifunction display	55
4	OPERATION	56
4.1.	Using the motorcycle	56
4.2.	Running-in	57
4.3.	Starting the engine	59
4.4.	Selecting and setting the display functions	61
4.4.1.	Selecting the display functions	62
4.4.2.	Setting the measurement units	63
4.4.3.	Resetting the trip mileage counters	66
4.4.4.	Setting the clock	69
4.5.	Refuelling	71
4.6.	Glove compartment	73
4.7.	Parking the motorcycle	75
4.8.	Preriding checks	77



CONTENTS

<i>chap.</i>	<i>Subject covered</i>	<i>page</i>	<i>chap.</i>	<i>Subject covered</i>	<i>page</i>
4.9	Riding	79	6.2.	Tools and accessories supplied	104
5	ADJUSTMENTS	80	6.3.	Table of lubricants and fluids	105
5.1.	List of adjustments	80	6.4.	Checking the engine oil level	106
5.2.	Table of adjustments	83	6.4.1.	Topping up the engine oil level	107
5.3.	Adjusting the front brake lever	84	6.5.	Checking the coolant level	109
5.4.	Adjusting the clutch lever	84	6.5.1.	Topping up the coolant level	110
5.5.	Adjusting the rearview mirrors	85	6.6.	Checking the wear of the brake pads	112
5.6.	Adjusting the front suspension	86	6.7.	Checking the brake fluid level	113
5.6.1.	Spring preload	87	6.8.	Checking the clutch fluid level	115
5.6.2.	Rebound damper (front suspension)	87	6.9.	Checking and replacing the tyres	116
5.6.3.	Compression damper (front suspension)	88	6.10.	Checking and lubricating the drive chain	121
5.7.	Adjusting the rear suspension	89	6.11.	Checking the idle speed	125
5.7.1.	Rebound damper (rear suspension)	90	6.12.	Replacing parts - General information	126
5.7.2.	High speed compression damper (rear suspension)	91	6.12.1.	Replacing the fuses	126
5.7.3.	Low speed compression damper (rear suspension)	91	6.12.2.	Replacing the low beam bulb	129
5.8.	Headlight adjustment	92	6.12.3.	Replacing the high beam bulb	131
6	MAINTENANCE	94	6.12.4.	Replacing the front parking light bulb	132
6.1.	Tables of scheduled maintenance and checks	94	6.12.5.	Replacing the front turn indicator bulbs	133
			6.12.6.	Replacing the rear turn indicator bulbs	134
			6.12.7.	Replacing the rear light and brake light bulb	135



CONTENTS

<i>chap.</i>	<i>Subject covered</i>	<i>page</i>
6.12.8.	Replacing the license plate light bulb	136
6.13.	Battery	138
6.14.	Cleaning the motorcycle	140
6.15.	Prolonged inactivity	143
7	TROUBLESHOOTING FLOW CHART	144
7.1.	Engine problems	144
7.2.	Electrical equipment problems	149
8	TECHNICAL INFORMATION	152
8.1.	Motorcycle overview	152
8.1.1.	Front brake circuit	154
8.1.2.	Rear brake circuit	155
8.1.3.	Clutch circuit	156
8.1.4.	Engine lubrication	157
8.1.5.	Coolant circuit	158
8.1.6.	Fuel system	159
8.2.	Specifications	160
8.3.	Accessories	167
8.4.	Clothing	168



INDEX

A

Accessories	167
– installation	26
Adjustments	
– clutch lever	84
– front brake lever	84
– front suspension	86
– headlight	92
– list	80
– rear suspension	89
– rearview mirrors	85
– table	83

B

Battery	138
Brakes	
– fluid level, check	113
– front brake circuit	154
– front brake lever, adjustment	84
– pads, wear check	112
– rear brake circuit	155
Bulbs, replacement of	
– front turn indicators	133
– high beam	131
– license plate light	136
– low beam	129
– parking light	132

– rear light and brake light	135
– rear turn indicators	134

C

Chain	
– check	121
– lubrication	123
Cleaning the motorcycle	140
Clutch	
– circuit	156
– fluid level, check	115
– lever, adjustment	84
Competitions	29
Controls and instruments, location	40
Coolant	
– level, check	109
– circuit	158
– topping up	110

D

Damper	
– compression (front suspension)	88
– compression (rear suspension)	91
– rebound (front suspension)	87
– rebound (rear suspension)	90



INDEX

Display, multifunction	55
– selecting functions	62
– setting functions	63
E	
Electrical equipment, troubleshooting	149
Engine	
– lubrication	157
– oil level, check	106
– oil level, topping up	107
– serial number	13
– starting	59
– troubleshooting	144
F	
Fuel system	159
Fuses, replacement	126
G	
Gear lever	52
Glove compartment	73
H	
Handlebar controls	
– left side	43
– right side	45
Headlight, adjustment	92
– high beam, bulb replacement	131
– low beam, bulb replacement	129
I	
Identification data	13
Idle speed, check	125
Ignition switch and steering lock	48
Instruments and warning lights	53
L	
Levels	
– brake fluid	113
– clutch fluid	115
– coolant	109
– engine oil	106
License plate light, bulb replacement	136
Location of controls and instruments	40
Lubricants and fluids, table	105
M	
Maintenance and checks, tables	94
Motorcycle color combination	20
Motorcycle overview	152
P	
Parking	75
Parking light, bulb replacement	132
Precautions for children	25
Preriding checks	77
Prolonged inactivity	143
Purpose of manual	10



INDEX

R		
Rear light and brake light, bulb replacement	135	
Rearview mirrors, adjustment	85	
Refuelling	71	
Replacing parts, general information	126	
Running-in	57	
S		
Safety	22	
– labels, location	35	
– recommendations for safe riding	30	
– rules	23	
– visual and acoustic signals	39	
Scheduled maintenance tables	94	
Sidestand	42	
Specifications	160	
Spring preload	87	
Suspensions		
– front, adjustment	86	
– rear, adjustment	89	
Symbols	11	
T		
Tampering, note	22	
Tools and accessories supplied	104	
	Topping up	
	– coolant	110
	– engine oil	107
	Troubleshooting flow chart	
	– electrical equipment	149
	– engine	144
	Turn indicators	
	– front, bulb replacement	133
	– rear, bulb replacement	134
	Tyres, check	116
	– puncturing	117
	– replacement	118
V		
	Vehicle	
	– identification number	13
	– load	27
	– modifications	29
W		
	Warning lights	54
	Warranty	
	– Booklet, Service Coupons and Dealers' Guide	12



1

1.1. Purpose of the manual

In addition to providing directions on operation and maintenance, this manual contains important information about general safety: **READ THE MANUAL OVER CAREFULLY BEFORE FIRST USING THE MOTORCYCLE.**

The manual describes the model with the maximum equipment at print time.

This manual must be considered as a part of your motorcycle. It must always be kept inside it, and it must be included with the vehicle even if this one is sold back to another owner.

The manual must be kept in the glove compartment placed under the passenger's seat.

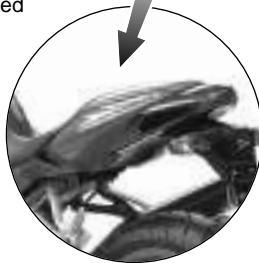



1.2. Symbols

Sections of text that are particularly important in terms of personal safety or possible damage to the motorcycle are marked with the following symbols:



Danger - Failure to observe these prescriptions, even in part, may pose a serious hazard to the driver's and other people's safety.



Caution - Failure to observe these prescriptions, even in part, may result in damage to the motorcycle.

The following symbols give an indication of who is supposed to perform the different adjustments and/or maintenance operations:



Information on operations that can be carried out by the user.



Information on operations that must be carried out only by authorized personnel.

The following symbols are used to provide further information:



The “” symbol points out the requirement to use a tool or a special equipment in order to correctly perform the described operation.



The “§” symbol refers the reader to the chapter identified by the number that follows.



1.3. Warranty Booklet and Service Coupons

Besides this Use and Maintenance Manual, the vehicle is accompanied by the following documents: a Warranty Booklet containing a Warranty and Pre-Delivery Certificate and recommended service coupons, and the MV Agusta Dealers' Guide.

IMPORTANT

The copy of the Warranty and Pre-Delivery Certificate to be sent to MV Agusta must be filled in by the dealer and returned to the factory within 10 days from the date of registration.

Every time the vehicle is serviced by a dealer, the user must produce the Warranty Booklet so that the dealer can fill in the service coupon and return it to MV Agusta within 10 days from the date of the servicing.



1.4. Identification data

- 1) vehicle identification number
- 2) engine serial number
- 3) homologation data

► Motorcycle identification

The motorcycle is identified by the vehicle identification number. When placing orders for spare parts, in addition to this number, you may be required to provide the engine serial number, the colour code and the key identification.

We recommend writing down the main numbers in the spaces provided below.

FRAME No.: _____

ENGINE No.: _____



1

Here below you can find a description of a vehicle identification number:

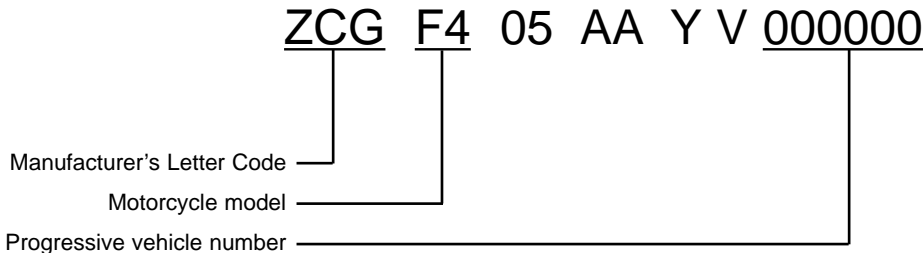

The vehicle identification number must be provided each time you need to contact the MV Agusta Technical Assistance Service, in order to guarantee the traceability of your motorcycle.



► Motorcycle key identification

A key is supplied in duplicate for both the ignition and all the locks. Keep the duplicate in a safe place.

It is essential to provide the key identification number if you place an order for a spare motorcycle key. We recommend writing down this number in the space provided below:

KEY No.:

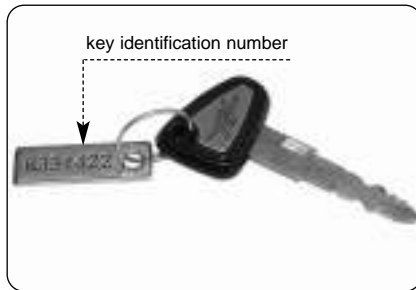



1



**► Bodywork parts reference colours**

Bodywork parts are painted with the following reference colours, according to the corresponding motorcycle colour combination (see page 20):

1. - Rear side fairing, right-hand;
2. - Rear side fairing, left-hand;
3. - Front mudguard:

Colour combinations A-D:

CRC B4 Red Painting

(Code Palinal 926XH348D)

Colour combination B:

Brutale Metal Matt Black Painting

(Code Palinal 925XH982)

Colour combination C:

CRC B4 Silver Painting

(Code Palinal 900.Crom)

4. - Fuel tank:

Colour combination A:

CRC B4 Red Painting

(Code Palinal 926XH348D)

Colour combination B:

Brutale Metal Matt Black Painting

(Code Palinal 925XH982)

Colour combination C:

CRC B4 Silver Painting

(Code Palinal 900.Crom)

Colour combination D:

CRC Intense Black Painting

(Code Palinal 9269011503395)

5. - Tail piece;
6. - Air box side fairings;
7. - Ignition switch cover;
8. - Dashboard cover:

Brutale Metal Anthracite Grey Painting

(Code Palinal 926XH893 Multicryl)

9. - Fuel tank left-hand side fairing;
10. - Fuel tank right-hand side fairing;
11. - Right-hand rearview mirror;
12. - Left-hand rearview mirror:

Brutale Metal Anthracite Grey Painting

(Code Palinal 926XH893 Multicryl)



1





► Frame parts reference colours

Frame parts are painted with the following reference colours:

1. - Frame;

Colour combinations A-B-C:

Brutale Metal Anthracite Grey Painting

(Code Palinal 211XH893)

Colour combination D:

F4 AGO Red Painting

(Code Palinal 211XH987)

4. - Front wheel rim;

5. - Rear wheel rim:

Aluminium Grey Painting

(Code Sebino 35204189) +

Transparent Painting

(Code Sebino 35209052)

2. - Rear frame;

3. - Silencers clamp:

Brutale Metal Anthracite Grey Painting

(Code Palinal 211XH893)

6. - Engine:

MV Metal Grey Painting

(Code Palinal 211.R129)



1

► Identification of motorcycle colour combination

The colour code must be mentioned when ordering body spares. It can be read on the lower left side of the fuel tank.

In order to get to the colour code label, it is necessary to remove the fuel tank left-hand side fairing.

Pull out the rear part of the fuel tank left-hand side fairing as shown in the figure.

Remove the fuel tank left-hand side fairing by pulling it towards the rear part of the motorcycle.

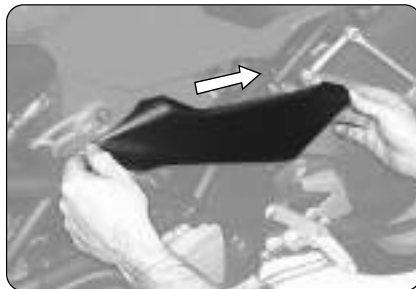
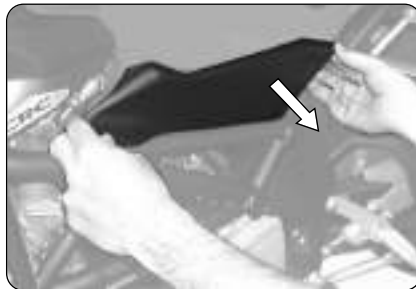



After removing the fuel tank left-hand side fairing, it is possible to get to the colour code label. On this label you can read the motorcycle colour combination, which determines the painting of the bodywork parts.

We recommend writing down the colour code in the space provided below:

COLOUR CODE :

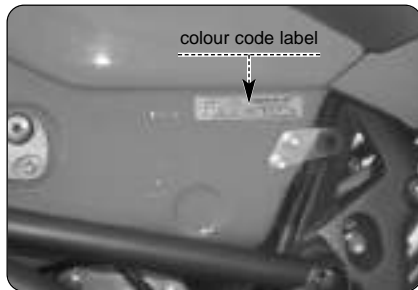



2.1. Safety

2.1.1. NOTE ON TAMPERING

2

Tampering with the noise control system is prohibited. In particular, the law prohibits the following acts:

1. The removal or rendering inoperative, other than for purposes of maintenance, repair, or replacement, of any device or element of design incorporated into any new vehicle for the purpose of noise control prior to its sale or delivery to the ultimate purchaser or while it is in use.
2. The use of the vehicle after such device or element of design has been removed or rendered inoperative.

Acts presumed to constitute tampering include:

1. The removal or piercing of the exhaust silencer, the diaphragm, the manifolds, or any other components involved in the transmission of exhaust gases.

2. The removal or piercing of any part of the intake system.
3. Poor maintenance.
4. The replacement of any movable parts of the vehicle or of any intake or exhaust components with parts or components other than those prescribed by the manufacturer.

NOTE

If you notice a progressive increase of the noise level of your motorcycle, MV Agusta recommends to have your noise control system controlled and if necessary replaced.

Otherwise, riding with a defective muffler can subject you to the penalties prescribed by state and local provisions.



2.1.2. SAFETY RULES



IMPORTANT: READ BEFORE USE

► **Before riding**, carefully read this manual so as to familiarize yourself with the controls, characteristics, working and limits of the motorcycle. The manual is aimed at providing information on some of all the possible techniques and methods required for safe riding.

► **Do not attach a sidecar, a trailer or any other accessory to the motorcycle.** Failure to observe this warning may make the vehicle unstable and cause serious accidents.

► **To ensure maximum reliability and maintain the vehicle in perfect working order**, it is essential to perform the servicing detailed in the Scheduled Maintenance Table and to follow all the instructions provided in this manual. For further information, speak with your dealer, who will have the necessary technical skills and information to assist you.

► **MV Agusta** continually strives to improve the quality of all of its motorcycles. Therefore, modifications that improve the performance of the bike are made as soon as they are developed. Therefore, your motorcycle may not be described exactly by the illustrations and text contained in this manual.

► **If you find difficulties in understanding any picture or information contained in this manual**, contact your MV Agusta dealer to obtain the necessary explanations.

► **If you find difficulties in reading any information contained in this manual**, contact your MV Agusta dealer.

► **In order to avoid compromising handling and stability of your motorcycle**, you should obey the following warnings:

- do not attach any object to the vehicle;
- do not remove any part and/or component;
- do not modify the vehicle in any way;
- do not wear garments that could adversely affect control and handling of the motorcycle.



- ▶ **Do not ride this motorcycle if you do not possess a regular driving licence.** Failure to heed this warning constitutes a breach of the Highway Code, besides posing a serious hazard to the driver's and other people's safety.
- ▶ **Do not try to service or repair this motorcycle if you do not possess the necessary skills.**
- ▶ **Motorcycle riding demands your complete attention.** Do not ride if you are ill, in poor physical condition, or because of worry, etc., unable to concentrate on the task at hand.
- ▶ **Always wear a helmet, even on short rides.**
- ▶ **Always wear suitable clothes, especially when travelling by night (e.g. garments with fluorescent bands).**
- ▶ **When refuelling, switch off the engine and refrain from smoking.**
- ▶ **Since petrol is highly flammable, avoid spilling the fuel onto the tank and the exhaust pipes when refuelling.**
- ▶ **When refuelling, stay away from the vehicle to avoid inhaling harmful fumes.** Should the fuel come into contact with the skin or clothes, immediately wash with water and change the contaminated garments.
- ▶ **When travelling during the day, use the low beam.**
- ▶ **Do not start the engine in closed places.** Exhaust gases are toxic and can quickly saturate the air and cause fainting or even death.
- ▶ **Before starting the engine in a closed place, ensure that the area is well ventilated.**
- ▶ **While the vehicle is in motion, always rest the feet on the specially designed supports.**
- ▶ **While riding, always keep both hands on the handlebars.**
- ▶ **Do not cover your motorcycle with a canvas soon afterwards riding.** Before covering your motorcycle, wait until the engine and the exhaust pipes have thoroughly cooled.



► If your motorcycle has been involved in an accident, check all levers, wires, hoses, brake calipers and other main parts for damage. Do not use the vehicle if you detect a damage that could adversely affect safety. Have all the main parts checked by an authorized MV Agusta dealer, in order to verify the absence of defects and/or damages that the owner could not be able to detect.

2.1.3. PRECAUTIONS FOR CHILDREN



WARNING

- Park the vehicle where it is unlikely to be bumped into or damaged. Even slight or involuntary bumps can cause the vehicle to topple over, with subsequent risk of serious harm to people or children.
- To prevent the vehicle from tipping over, never park it on soft or uneven ground, nor on asphalt strongly heated by the sun.
- Engine and exhaust pipes become very hot during riding. Always park your motorcycle where people or children can not easily reach these parts, in order to avoid serious burns.

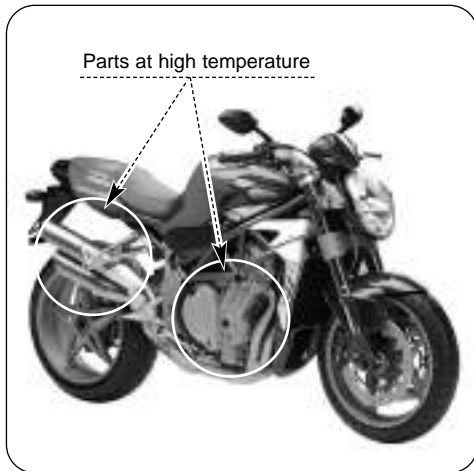



2.1.4. INSTALLING ACCESSORIES

MV Agusta provides a range of accessories specially designed for your vehicle. It is essential that these accessories are installed by an MV Agusta dealer.



WARNING

Use only MV Agusta original accessories. The use of non-genuine accessories can make the vehicle unsafe by reducing its handling, stability and the effectiveness of the braking system. For this reason, the installation of any non-genuine accessory makes the warranty null and void and relieves MV Agusta of all responsibility.

► Every time you apply accessories that affect the weight and/or the aerodynamic characteristics of your motorcycle, they must be assembled on its lower side and near to its center, as much as it is

possible. The brackets and the anchor bolts must be carefully checked after the assembling, to ensure a stable framework and an unmovable support for the accessory. In fact, an eventual breaking of these stands could cause dangerous situations during riding.

► Verify that the assembling of the accessories does not cause a reduction of the minimum ground clearance and of the inclination of your motorcycle. Moreover, verify that the assembling of the accessories does not cause any interference with the handling of the steering system, with the travel of the suspensions and/or with the movement of any other component involved in driving.

► Any accessory positioned on the handlebar or on the front fork can reduce the handling and adversely affect the stability of the vehicle. Therefore, the choice of the accessories should be accurate and restricted to components of light weight and small dimensions only.

► Your motorcycle could undergo lightening or other instability effects in case of wind blowing



sideways and transversely; this may also happen when your motorcycle runs into or it is overtaken by vehicles of great dimensions. Under these conditions, the accessories adversely affect your driving safety, especially if they are incorrectly assembled or of the wrong type. It is therefore necessary to pay great attention in choosing and assembling any accessory.

► **Some accessories force the rider to drive in an unnatural position. This may obviously restrict your freedom of movement and cause loss of control of the vehicle.**

► **Additional electric accessories can cause an overload of the electrical system of your motorcycle; this could damage the wires, causing danger of short circuit and electric shock.**

2.1.5. VEHICLE LOAD

Your motorcycle is designed for use by the rider and it can also seat a passenger. To use the vehicle in complete safety and in accordance with the Highway Code provisions, it is compulsory that the following maximum load conditions are never exceeded:

BRUTALE S 370 kg

This value comes out from the sum of the following weights, according to the European standard CEE 92/61:

- weight of the motorcycle;
- weight of the driver;
- weight of the passenger;
- weight of the load and all the accessories.



2

**WARNING**

Since the load can strongly affect handling, braking, performance and safety characteristics of your motorcycle, you should always keep in mind the following warnings.

- **NEVER OVERLOAD YOUR MOTORCYCLE!** Driving an overloaded motorcycle can cause damage to the tyres, loss of control of the vehicle and serious injury. Verify that the total weight (including the weight of the motorcycle, the driver, the passenger, the load and all the accessories) does not exceed the maximum load values specified for your vehicle.
- Before riding, always check the wear and the pressure of the tyres.

- Never carry any incorrectly fastened object on your motorcycle, because it could move from its position during riding.
- Steadily fasten the heaviest objects near the center of the motorcycle, and equally divide the load on both sides of the vehicle.
- Do not insert any object or accessory in the spaces on the frame trellis, in order to avoid interfering with the movable parts of the motorcycle.
- Adjust the suspensions according to the load.
- Even if the motorcycle is correctly loaded, drive with caution and never exceed 130 km/h when you carry a load.



2.1.6. MODIFICATIONS

MV Agusta suggests neither to remove any original device, nor to modify the motorcycle in any way that could change its shape or its working.



WARNING

Any modifications made to the vehicle (e.g. alteration and/or removal of components) can make the vehicle unsafe or unlawful. **MV Agusta** cannot be held responsible for any damage to people and objects subsequent to eventual modifications made to the original conditions of your motorcycle. Modifying the vehicle immediately voids the warranty and relieves **MV Agusta** of all responsibility.

2.1.7. COMPETITIONS



WARNING: Riding the vehicle in competitions requires considerable skill and experience as well as an accurate setup of the motorcycle.



CAUTION: The high temperatures caused by the use of the vehicle on race circuits could compromise the efficiency of the catalytic converter and of the exhaust system; therefore, we suggest assembling a special exhaust system when using the vehicle on race circuits.

MV Agusta has designed a number of special components for use in competitions and/or sporting events. The use of such components is strictly limited to areas closed to traffic. Failure to observe this restriction constitutes a breach of the Highway Code for which **MV Agusta** cannot be held responsible.



2.1.8. RECOMMENDATIONS FOR SAFE RIDING

Besides being a means of transport, your motorcycle is a source of recreation and excitement. However, the configuration of the vehicle does not exclude a certain amount of risk. To ensure maximum safety, in addition to scrupulously observing the warnings and instructions provided in the previous paragraphs, it is essential to take a few additional precautions.

In particular:

Before starting off

Follow all the directions given in the section "PRE-RIDING CHECKS". Conduct an overall check of all safety-related aspects of the motorcycle.

Familiarizing with the vehicle

The rider's ability and his mechanical skills form the basis of riding safety. It is advisable to practise riding in areas without traffic until you have become familiar with the vehicle and its controls.

Being aware of one's limits

When riding, never exceed your limits nor those imposed by law. Being aware of your limits and acting accordingly will help you avoid accidents.

Adverse weather conditions

Be very careful when riding in adverse weather conditions. On wet roads, for example, the braking distance increases as a result of reduced tyre traction. It is therefore necessary to travel at moderate speed and avoid abrupt braking and acceleration. Pay particular attention when riding on slippery surfaces such as road markings, manholes, level crossings, bridges, gratings, etc. Considering that a motorcycle cannot provide the same degree of shock protection as a motor vehicle, it is essential to adopt a "defensive" riding attitude, particularly in the adverse weather conditions described above.



► **Keeping even one foot or hand away from their designed supports could cause loss of control of the vehicle and increase the risk of accidents. Always keep both hands on the handlebars and both feet on the footrests during riding.**

► **Change gears as necessary to ensure that the proper gear ratio is chosen in all riding conditions, allowing the engine to run at optimum speed at all times. Avoid high gear ratios when travelling at reduced speed (excessively low rpm) as well as low gear ratios when travelling at high speed (excessively high rpm).**

► **Always operate the clutch system when you change gear, in order to avoid damage of the engine, of the gearbox and of the transmission. These components have not been designed to take the shocking stress caused by the forced coupling of a gear.**

► **Do not keep the clutch disengaged for a long time during riding, unless you have to change gear. Failure to heed this warning may lead to the**

overheating and to the abnormal wear of the clutch components.

► **When rapid acceleration is required (e.g. when passing), select a lower gear to obtain better acceleration.**

► **When the motorcycle is being ridden at high speed, gearing down several times in rapid succession can cause the engine to overspeed. As a result, the rear wheel may lock, causing loss of control of the vehicle, as well as damage to the engine and transmission.**

► **When riding down long hills, reduce the speed of your motorcycle by closing the throttle and using a low gear ratio to take advantage of engine braking. Use the front and rear brakes as little as possible to maintain your speed, in order to prevent brake overheating and fade.**

► **Special attention should be given to the braking system, which plays a key role in ensuring safety. When braking, always take account of the speed of the vehicle and the condition of the road surface.**



The braking action should always be applied gently and gradually to both wheels.

Performing this operation and, more in general, riding the vehicle always requires the utmost care. Therefore, caution should be exercised by all users, and in particular by inexperienced riders.

► **When you make a turn, avoid sudden braking.** Failure to observe this warning could lead to the sliding of the wheels and the loss of control of the vehicle. Always operate the brakes before starting a turn.

► **When you are laterally blown by a sudden gust of wind (as it may happen when you're overtaken by a vehicle of great dimensions, when you come out of a tunnel or when you're driving in a hilly zone), you could lose control of the vehicle.** While driving under the above mentioned conditions, reduce your speed and be careful to avoid sideways gusts of wind.

► **Maintain a safe distance behind vehicles in front of you and adjust your speed to the weather and traffic conditions.** Remember that, as your bike picks up speed, stopping distances increase and the motorcycle becomes more difficult to control. In any case, never exceed the speed limits imposed by the Highway Code.

► **When travelling during the day, keep the low beam on in order to be better seen by other road users.**

► **It is strictly forbidden to drink alcoholic beverages or take drugs before riding.** Even very small amounts of these substances adversely affect the rider's ability to control the vehicle.



2.1.9. PROTECTIVE CLOTHING

Helmet wearing is compulsory under the Highway Code. Helmet is the most important part in the biker's protective clothing, because it protects him from head injury in the event of an accident. Always fasten your helmet properly and securely. If you wear an open-face helmet, also wear goggles. Without a protective shield, in fact, wind racing on your face during driving could reduce your visual capacity, increasing the risk of accidents.



WARNING: Failure to wear a helmet increases the risk of serious injury or even death in the event of an accident. Make sure that you and your passenger always wear an approved helmet during driving. If you wear an open-face helmet, also wear protective glasses.

Always wear suitable protective clothing. In particular, the following items should be worn:

- ▶ A close fitting jacket, made of tough material and easy to fasten.
- ▶ Supple, reinforced gloves providing both sensitivity and protection.
- ▶ Strong, close-fitting trousers covering the legs completely.
- ▶ Soft, reinforced boots providing both sensitivity and protection.

The items mentioned above are available from any specialized shop.

We recommend buying brightly coloured clothes, as they make the rider easier to see at night and in the fog.

In any case, the clothes must allow complete freedom of movement and not hamper the rider in any way. In addition, they must have no loose parts capable of catching in the control levers, the footrests, the wheels, the drive chain, etc., in order to avoid dangerous situations.

**WARNING**

Protective clothes do not afford complete protection against the risk of personal injury in the event of an accident. It is therefore essential not be deceived by the false sense of security that you might perceive by wearing protective clothing. When riding, always adopt a cautious attitude and follow the recommendations given in the previous paragraphs.

2.1.10. SUGGESTIONS AGAINST THEFT

1. Every time you park your motorcycle, operate the steering lock and remove the ignition key (see § 3.5.).
2. Park your motorcycle in a closed garage every time it is possible.
3. Install a good quality anti-theft device on your vehicle.

4. Always keep up to date the registration data of your motorcycle.
5. Write down your name, address and phone number in the spaces provided down below, and always keep this use and maintenance manual inside the glove compartment of your motorcycle (see § 4.6.). This is very important, because a stolen motorcycle can be subsequently identified by reading the informations written in the manual found inside it.

NAME: _____

ADDRESS: _____

PHONE NUMBER: _____



2.2. Safety Labels - Location

- 1 - Unleaded petrol
- 2 - Battery warning
- 3 - Tyre pressure
- 4 - Rear wheel hub warning
- 5 - Chain adjustment

NOTE

The labels in the following pages do not appear in their real size. If you find difficulties in understanding any of these labels, contact an authorized MV Agusta dealer.

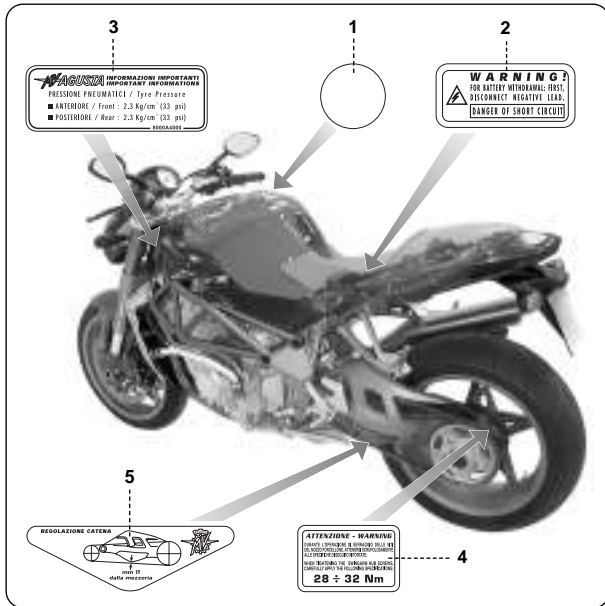



1. ADHESIVE LABEL –
UNLEADED PETROL

2

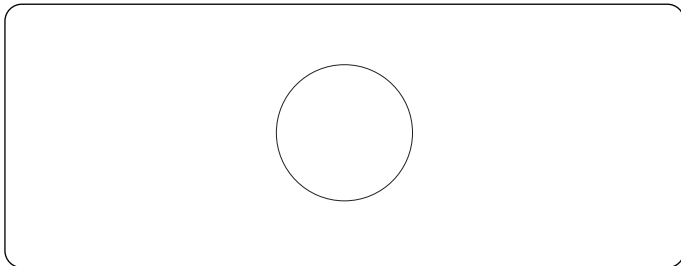

2. ADHESIVE LABEL –
BATTERY WARNING

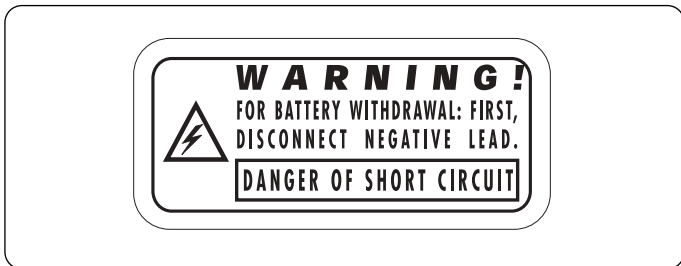



3. ADHESIVE LABEL – TYRE PRESSURE



4. ADHESIVE LABEL – REAR WHEEL HUB WARNING





**5. ADHESIVE LABEL –
CHAIN ADJUSTMENT**

2

REGOLAZIONE CATENA

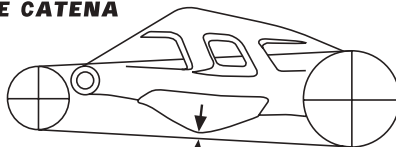

**mm 11
dalla mezzeria**



2.3. Safety - Visual and acoustic signals

Before each ride, it is essential to verify the operation of the visual and acoustic signals.

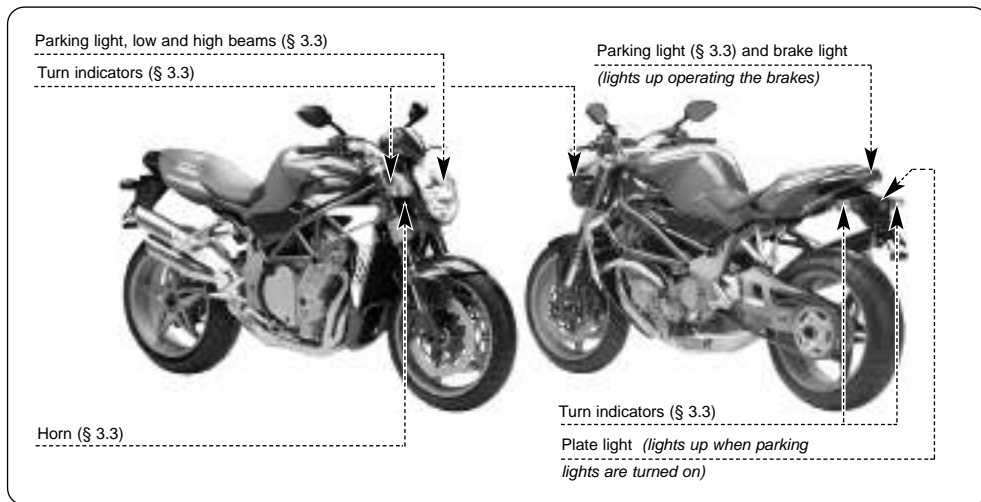



3.1. Location of controls and instruments

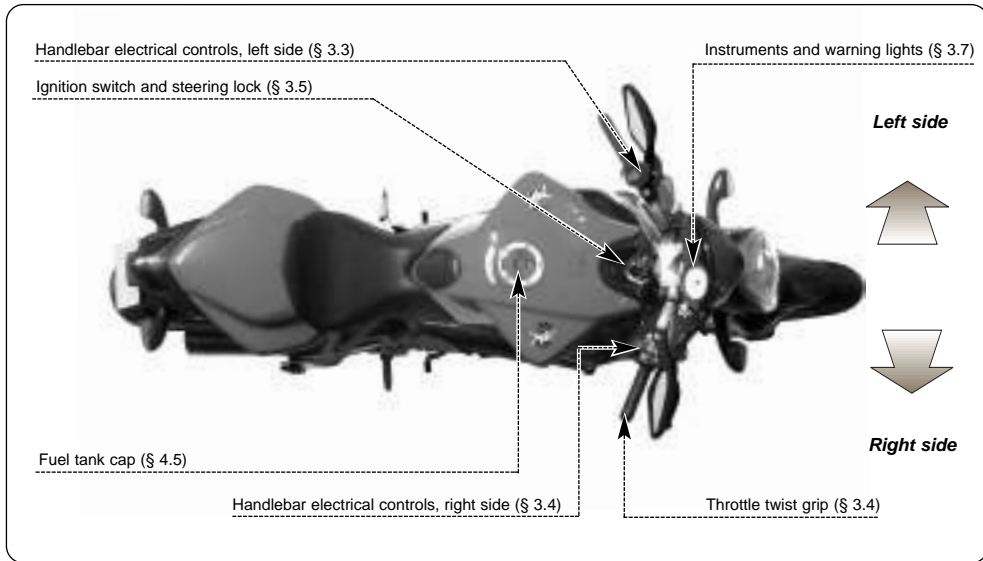

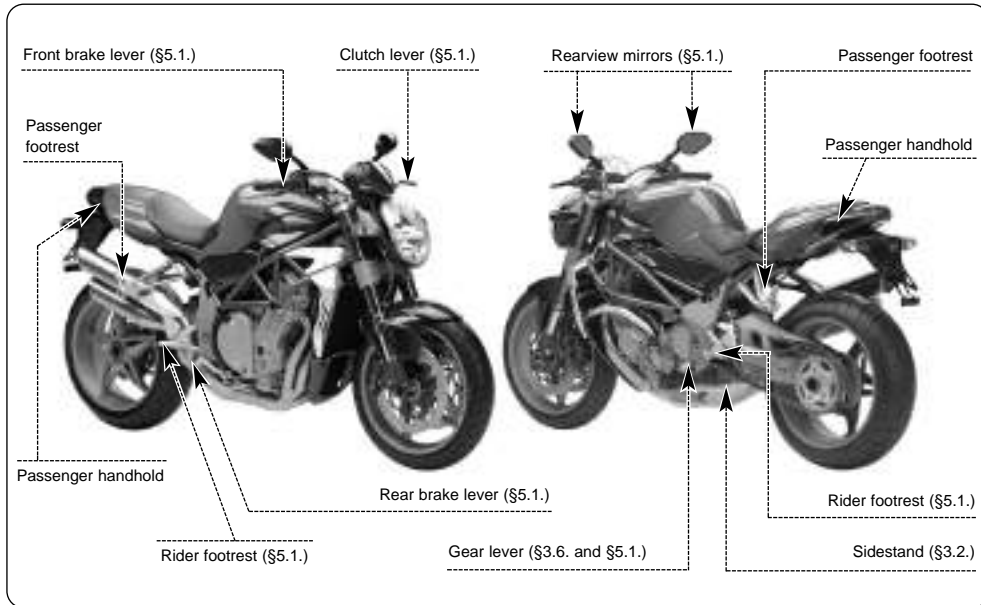



3.2. Sidestand

The sidestand is equipped with a safety switch that prevents the motorcycle from moving off while the stand is down.

If the rider attempts to engage the gears while the engine is running and the stand is down, the switch automatically turns off the engine by cutting the current supply.

If the motorcycle is parked (side-stand down) and the gears are engaged, the switch prevents the engine from being started, thereby avoiding the risk of accidentally toppling the vehicle.

3

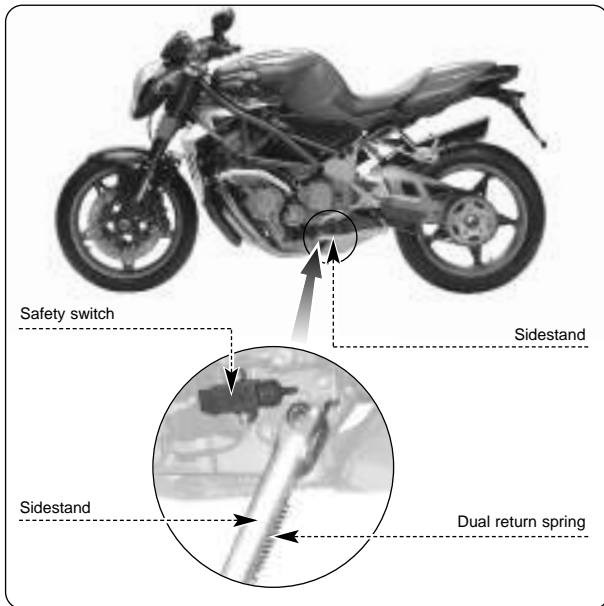



3.3. Handlebar controls, left side

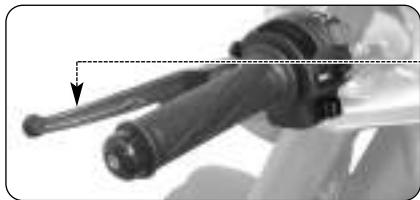

Clutch lever

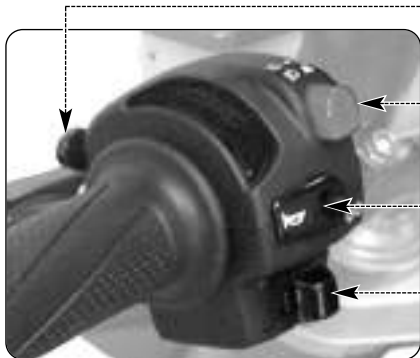

Move towards/away from the handgrip to release/engage the clutch.



High beam flasher button

Press the button repeatedly.

Low/high beam button

Button not pressed in  : low beam 

Button pressed in  : high beam 

Horn button

Press to operate the warning horn.

Turn indicator switch

Shifting the lever to the left or right switches on the left or right turn indicators. The switch then returns to the central position. Press to turn off the indicators.



High beam flasher button

It is used to attract the attention of other road users in case of danger. When the high beam is on, the function is inactive.

Low/high beam button

Under normal conditions, the low beam is on. The high beam can be switched on by pressing the button when allowed by the traffic and road conditions.

Turn indicator switch

It is used to show the rider's intention to change direction or lane.



WARNING

Failure to switch the turn indicators on or off at the right time may cause an accident in that the other road users may draw incorrect conclusions about the direction of motion of the vehicle. Always switch on the indicators before turning or changing lanes. Then be sure to switch off the indicators after completing the operation.

Horn button

It is used to attract the attention of other road users in case of danger.

Clutch lever

It engages/disengages the clutch through a hydraulically controlled device.



3.4. Handlebar controls, right side

Front brake lever

Pull to the lever to apply the front brake.

Throttle twist grip

Rotate counterclockwise to increase engine speed.

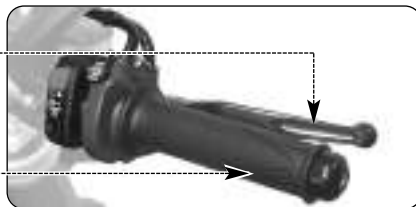

Cold start (choke) lever

Rotate clockwise when cold starting. After the engine has run for a few seconds, return the lever to its original position.

Engine stop switch

Stops the engine and prevents it from being restarted.

Engine start button

Starts the engine. To be released as soon as the engine starts. When the engine is running, pressing the button selects the display functions.



**Engine stop switch**

It is used to switch off the engine in an emergency. The ignition circuit is disabled, preventing the engine from being restarted. To be able to restart the engine, return the switch to its original position.

NOTE

Under normal conditions, do not use this switch to shut off the engine.

3**Engine start button**

It is used to start the engine and, when the engine is running, to select the different functions of the display installed on the instrument panel.

**CAUTION**

To avoid damaging the electrical equipment, be sure not to hold down the button for longer than 5 consecutive seconds.

If, after some attempts, the engine does not start, refer to the chapter “TROUBLESHOOTING” later in this manual.

Cold start (choke) lever

It facilitates cold starting by slightly enrichening the fuel-air mixture during start-up.

NOTE

This function must remain active only for a short time depending on the engine and environmental temperature. As soon as the idle speed keeps the engine running, it is advisable to disable the control.



Throttle twist grip

It controls the fuel-air mixture supplied to the engine, which regulates engine speed. To increase engine speed, rotate the hand grip from its idle position counterclockwise.

When cold starting (choke on), rotating the throttle twist grip clockwise fully causes the choke lever to return to its original position.

Front brake lever

It controls a hydraulic circuit that operates the front wheel braking system.

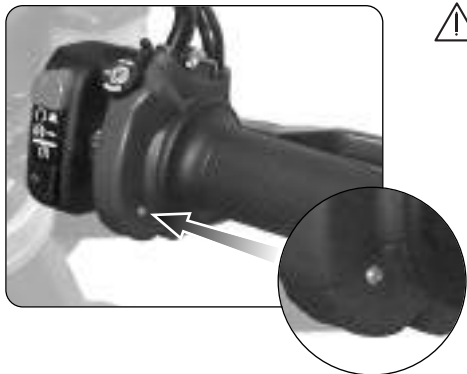

WARNING

In some countries, the laws in force impose the restriction of vehicles' engine power. Under these conditions, the throttle twist grip of your motorcycle must be equipped with the mechanical device shown in the picture on the left. This device must neither be removed nor tampered in any way. The removal or tampering of the above device leads to the following events:

- violation of the laws in force in the country in which you use your motorcycle;
- damage to the motorcycle;
- compromising of the safety conditions;
- loss of the warranty rights.



3.5. Ignition switch and steering lock



WARNING

Do not attach a ring or any other object to the ignition key as they may hinder the steering action.



WARNING

Never attempt to change the switch functions while riding, as you may lose control of the vehicle.

3

Ignition switch and steering lock

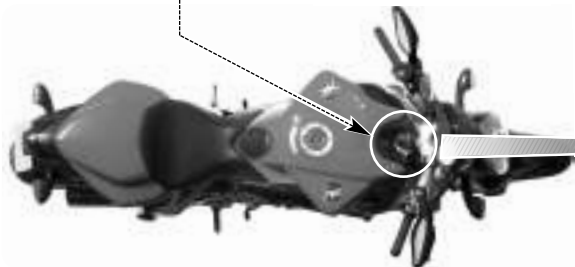

OFF Position

ON Position

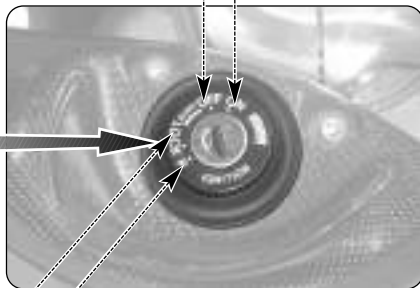

LOCK Position

P (Parking) Position



The ignition switch enables and disables the electrical circuit and the steering lock. The four positions of the switch are described below.

OFF position

All electrical circuits are deactivated. The key can be removed.



ON position

All electrical circuits are activated. The instruments and warning lights perform the self-diagnostic cycle. The engine can be started. The key cannot be removed.



3



CAUTION: Do not leave the key on the ON position for a long time when the engine is not running, in order to avoid damage to the electrical parts of the motorcycle.



LOCK position

Turn the handlebar to the left. Press the key gently while rotating it to the LOCK position. All electrical circuits are deactivated and the steering is locked. The key can be removed.

3

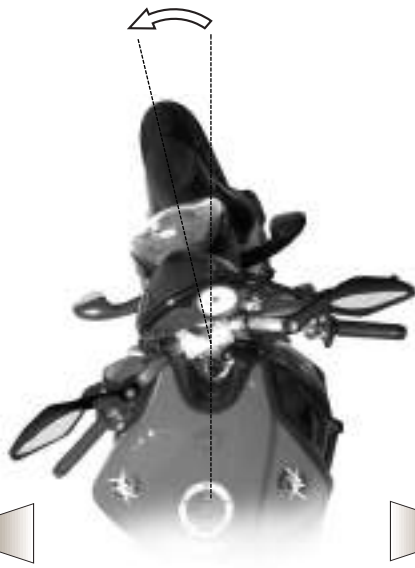

Left side

Right side



P (PARKING) position

Turn the key from the LOCK position to the P position. All electrical circuits are deactivated except the parking lights. The steering is locked. The key can be removed.



CAUTION

Do not leave the key on the P position for a long time, in order to avoid discharging the battery of your motorcycle.





3.6. Gear lever

The **N** (neutral) position is indicated by the warning light on the instrument panel.

To change into first gear, push the lever down.

To change into second gear, lift the lever up. Lifting the lever up repeatedly engages all the other gears in succession up to the sixth speed.

3



Gear lever

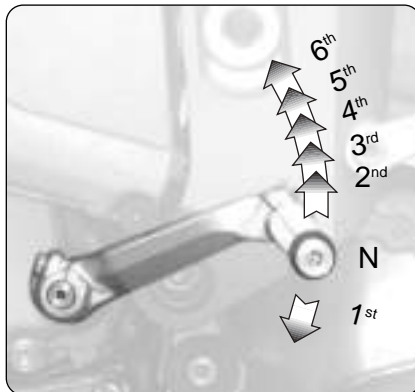



3.7. Instruments and warning lights

The instruments and warning lights are activated by turning the ignition switch to the ON position. After a preliminary check (approx. 7 seconds) the displayed information reflects the current general condition of the motorcycle.

Warning lights
(§3.7.1.)

SET button (§3.7.2.)

Multifunction display (§3.7.2.)

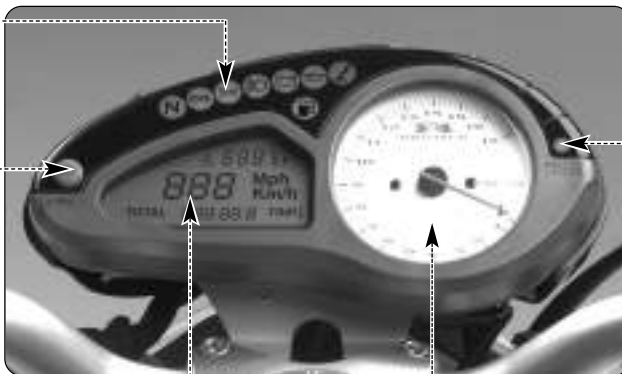

Warning light
(§3.7.1.)

Tachometer



3.7.1. Warning lights

High beam warning light (blue)
Lights up when the high beam is activated.

Battery charge indicator (red)
Lights up when the alternator does not supply enough current to charge the battery.

If the indicator comes on while riding, contact an authorized service centre.

Low beam warning light (green)
Comes on when the low beam is activated.

Sidestand down warning light (red)
Lights up when the sidestand is down.

Neutral indicator (green)
Lights up when the gears are in neutral.

Rev limiter warning light (red)
Lights up when the engine speed exceeds 12,700 rpm. The rev limiter limits the rpm to 13,100.

Turn indicator light (green)
Lights up when the turn indicators are activated.

Engine oil pressure warning light (red)
Lights up when the oil pressure is insufficient.

Reserve fuel indicator (amber)
Comes on when approximately 4 litres of fuel are left.



WARNING: If the warning light comes on while riding, stop the motorcycle immediately. Check and if necessary restore the oil level. If the warning light comes on even if the oil level is correct, do not resume riding and contact an authorized service centre.

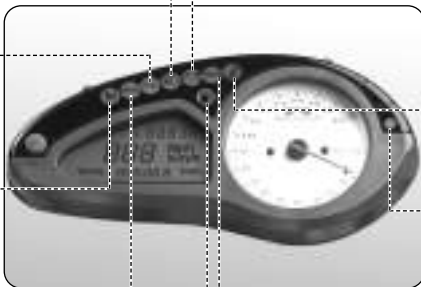



3.7.2. Multifunction display

Speedometer

Measures the speed of the vehicle. The speed can be displayed in kilometres per hour (km/h) or miles per hour (mph). The full-scale value is 299 km/h (185 mph).

SET button

Pressing the button allows the setting of the different display functions. Pressing the button again confirms the entered values.

TOTAL mileage counter

Displays the total distance covered: from 0 to 99,999.9 (km or mi)

TRIP 1 mileage counter

Displays a first trip mileage count: from 0 to 9,999.9 (km or mi)

TRIP 2 mileage counter

Displays a second trip mileage count: from 0 to 9,999.9 (km or mi)

Clock

Displays the time (0÷24)

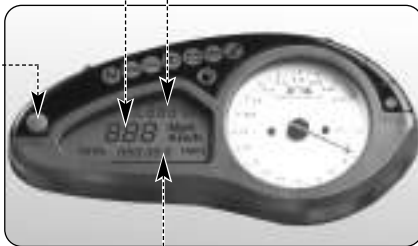

Thermometer

Displays the coolant temperature in degrees centigrade (°C) or Fahrenheit (°F).

The display range is 40° to 140° C (104° to 284° F):

- Below 40° C (104° F) no temperature is displayed but three blinking lines denote a very low temperature.

- Between 40° and 49° C (104° and 120° F) the temperature reading blinks to indicate a low temperature.

- Between 50° and 105° C (122° and 221° F) the temperature reading is fixed.

- Between 106° and 140° C (223° and 284° F) the temperature reading blinks to indicate a high temperature.



WARNING: If the temperature exceeds 120° C (248° F), stop the motorcycle immediately and check the coolant level. If the coolant level is low, carefully top up the coolant, after you have allowed the engine to thoroughly cool. Never attempt to remove the coolant filler cap when the engine is hot. If the high temperature indication is given even when the coolant level is correct, do not resume riding and contact an authorized service centre (see chapter 7 "Troubleshooting").



4.1. Using the motorcycle

This section provides the basic information needed to correctly operate the motorcycle:

- Running-in (§ 4.2)
- Starting the engine (§ 4.3)
- Selecting and setting the display functions (§ 4.4)
- Refuelling (§ 4.5)
- Glove compartment (§ 4.6)
- Parking the motorcycle (§ 4.7)
- Preriding checks (§ 4.8)
- Riding (§ 4.9)

4



WARNING: The F4 BRUTALE motorcycle shows high power and performance characteristics; therefore, its use requires an adequate level of knowledge of the vehicle. When you use this motorcycle for the first time, it is essential to adopt a cautious attitude. An aggressive or reckless riding attitude can lead to accidents, compromising the driver's and other people's safety.



CAUTION: The high temperatures caused by the use of the vehicle on race circuits could compromise the efficiency of the catalytic converter and of the exhaust system; therefore, we suggest assembling a special exhaust system when using the vehicle on race circuits.



Respect and defend natural environment

Everything we do affects the whole planet as well as its resources.

MV Agusta, in order to protect the interests of the community, awakens the Customers and the Technical Assistance operators to use the vehicle and dispose of its replaced parts respecting the laws in force concerning environmental pollution and waste disposal and recycling.



4.2 Running-in



CAUTION

Failure to observe the indications provided below can reduce performance and shorten the life of the motorcycle.

Running-in is generally considered to apply only to the engine. In fact, it should be regarded as an essential phase for other important parts such as the tyres, the brakes and the drive chain. During the very first miles, adopt a relaxed riding style.

□ 0 to 500 km (0 to 300 mi) (A)

Frequently change the engine speed. If possible, prefer hilly routes with gentle slopes and many bends. Avoid long straight stretches.



WARNING

New tyres must undergo a proper running-in period to reach their complete efficiency. Avoid abrupt acceleration, turning and braking during the first 100 km. Failure to observe these prescriptions can lead to the sliding of the wheels and the loss of control of the vehicle with subsequent risk of accidents.



❑ 500 to 1000 km (300 to 600 mi)

Avoid lugging or overspeeding the engine, and vary your speed frequently.



4

❑ 1000 to 2500 km (600 to 1600 mi)

Higher engine performance can be demanded, but it is advisable not to exceed the engine speed shown in the figure.

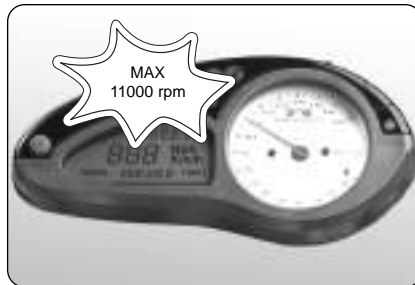



4.3. Starting the engine



WARNING

Starting the engine in a closed place can be dangerous. Exhaust emissions contain carbon monoxide, a colourless and odourless gas that can lead to serious harm or even death when inhaled.

Only start the engine outdoor, in the open air.

► As you turn the ignition switch to the ON position, the instruments and the warning lights will go through the self-diagnostic cycle; during this phase, make sure that all the warning lights on the dashboard come on. One of the following conditions must be verified, in order that the ignition switch system allows engine starting:

- The gears are in neutral.
- The gears are engaged, the clutch lever is pulled and the side stand is up.

❑ Cold starting

► Rotate the CHOKE lever without turning the throttle twist grip and then press the start button.

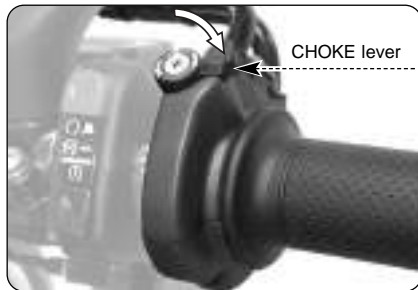



▶ As soon as the engine starts, release the button and, after warming up the engine for a short time, return the CHOKE lever to its original position.

❑ Hot starting

- ▶ Press the start button without turning the throttle twist grip.
- ▶ As soon as the engine starts, release the button.

4



CAUTION

- Do not press the start button for longer than 5 consecutive seconds, in order to avoid damage to the electrical equipment.
- Avoid warming up the engine while the vehicle is stationary. The subsequent engine overheating can cause damage to the internal parts of the engine. It is advisable to bring the engine to the working temperature by riding at reduced speed.
- To ensure the maximum life of the engine, never speed up at full throttle when the engine is cold.





4.4. Selecting and setting the display functions

The display functions allow to change some of the main measuring parameters.

The possible operations are listed as follows:

- Selecting the functions:

TOTAL	Mileage	Counter
TRIP 1	Mileage	Counter
TRIP 2	Mileage	Counter
Clock		
- Setting the following measurement units:

Speed
Mileage
Temperature
- Resetting the trip mileage counters:

TRIP 1	Mileage	Counter
TRIP 2	Mileage	Counter
- Setting the clock.





4.4.1. Selecting the display functions

You can select the following functions:

- TOTAL Mileage Counter
- TRIP 1 Mileage Counter
- TRIP 2 Mileage Counter
- Clock

4

► The TOTAL, TRIP 1 and TRIP 2 functions can be displayed by pressing the engine start button. Pressing the button repeatedly cycles through the different functions. Select the desired function.

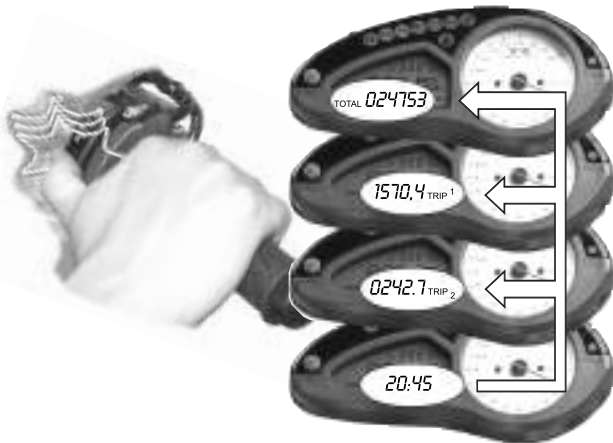

WARNING

The operation must be performed while the engine is running, the gears are in neutral, the motorcycle is stationary, and with the feet on the ground. Do not set the display functions while riding as it may cause loss of control of the vehicle.



4.4.2. Setting the measurement units

It is possible to set the measurement units of the displayed quantities.



WARNING

The operation must be performed while the engine is running, the gears are in neutral, the motorcycle is stationary, and with the feet on the ground. Do not set the display functions while riding as it may cause loss of control of the vehicle.

□ Speedometer (Km/h - Mph)

- ▶ Repeatedly press the engine start button until the TOTAL mileage counter is displayed.
- ▶ Press the SET button; the speedometer unit starts blinking.



4

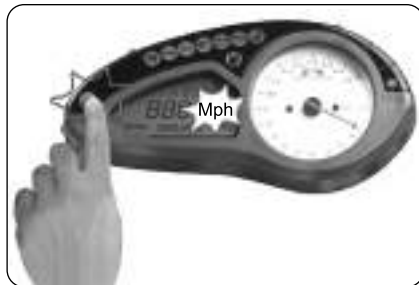



- ▶ Press the engine start button to toggle between Km/h and Mph. Changing the speedometer unit also changes the units for the total and trip mileage counters.

Remember that: 1 mi = 1,609 Km

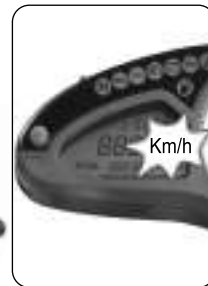

4

- ▶ Press the SET button to confirm the speedometer unit. The thermometer unit will start blinking, indicating that the display is ready for the next setting.





❑ Thermometer (° C - ° F)

- ▶ Press the engine start button to toggle between ° C and ° F.

Remember that: $T (^{\circ}\text{F}) = 1.8 \cdot t (^{\circ}\text{C}) + 32$



4

- ▶ Press SET to confirm the temperature unit.





4.4.3. Resetting the trip mileage counters

The TRIP 1 and TRIP 2 counters can be reset as follows:



WARNING

The operation must be performed while the engine is running, the gears are in neutral, the motorcycle is stationary, and with the feet on the ground. Do not set the display functions while riding as it may cause loss of control of the vehicle.

- ▶ Select the TRIP 1 function by pressing the engine start button.
- ▶ Press the button for longer than four seconds. The TRIP 1 mileage will start blinking.

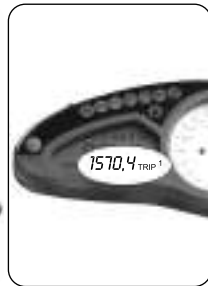



► Pressing the button for less than four seconds sets the mileage to zero. If, on the other hand, the button is pressed for longer than four seconds the entire resetting procedure is cancelled.

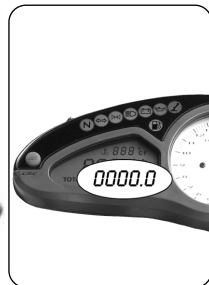
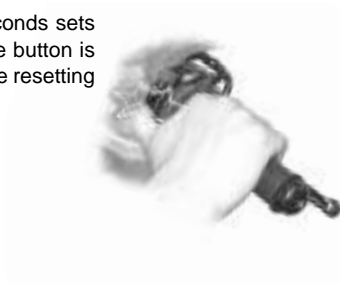

► Select the TRIP 2 function by pressing the engine start button.



4



► Press the engine start button for longer than four seconds; the TRIP 2 mileage will start blinking.



4

► Pressing the button for less than four seconds sets the mileage to zero. If, on the other hand, the button is pressed for longer than four seconds the entire resetting procedure is cancelled.

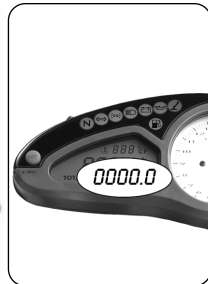



4.4.4. Setting the clock

It is possible to set the clock function.



WARNING

The operation must be performed while the engine is running, the gears are in neutral, the motorcycle is stationary, and with the feet on the ground. Do not set the display functions while riding as it may cause loss of control of the vehicle.

- ▶ Repeatedly press the engine start button until the time is displayed.
- ▶ Press the SET button – the first hour digit will start blinking.

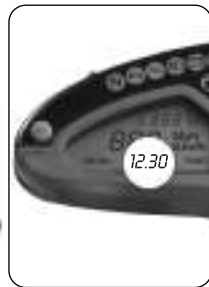



- ▶ Hold down the engine start button and release it as soon as the desired figure is displayed.

NOTE

To quickly cycle through the selected digit, hold the start button depressed for longer than two seconds.

- ▶ Press SET to confirm the first hour digit and to be able to set the following digit.

- ▶ Repeat the procedure to set the second hour digit and the first and second minute digits.

- ▶ Press SET to confirm the time and exit the set (blinking) mode.

NOTE

The instrument panel has an integrated memory which retains all the parameters even when the engine is not running. Except for the clock, which is reset, all the parameters are retained even when the battery is disconnected.

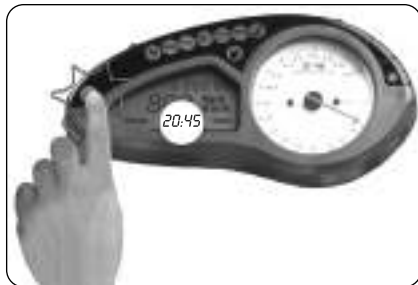



4.5. Refuelling



WARNING

Petrol and its fumes are highly toxic and flammable. Avoid contact and inhalation.

When refuelling, switch off the engine, avoid smoking, and keep away from flames, sparks and heat sources. Perform refuelling in the open air or in a well ventilated area.



CAUTION

Only use unleaded fuel with a R.O.N. octane rating of 95 or higher. The green dot on the lower side of the tank cap serves as a reminder of this.

- ▶ Lift the dust cover.
- ▶ Insert the key into the lock and rotate it clockwise.



4



- ▶ Lift the tank cap and operate the refuelling.



WARNING

Overfilling the tank may cause the fuel to overflow as a result of the expansion due to the heat from the engine or to exposure to sunlight. Fuel spills can catch fire. The level of the fuel in the tank must never be higher than the base of the filler.

4

- ▶ After refuelling, press down the tank cap while rotating the key clockwise to facilitate the locking. Then release the key and remove it.



CAUTION

Immediately wipe the overflowed fuel with a clean cloth, to avoid damage to the painted or plastic surfaces.



WARNING

Verify that the tank filler cap is correctly closed before using the motorcycle.

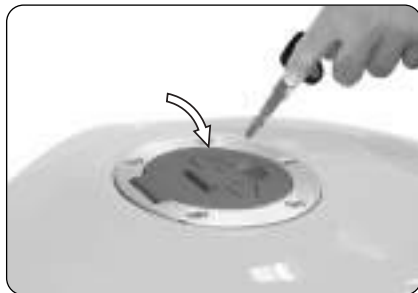
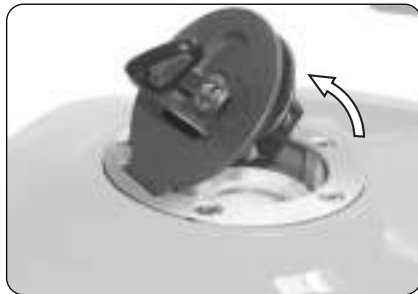



4.6. Glove compartment

► Insert the key into the lock.

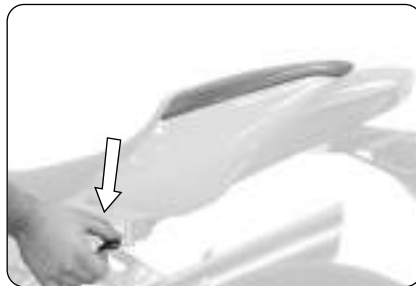

► Press down the pillion while turning the key clockwise. Lift the pillion.

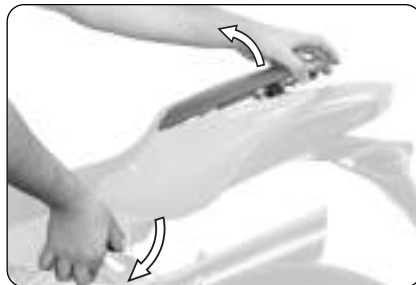

4



- Remove the pillion.

In order to reassemble the above mentioned part, you must perform the following operations:

- Rotate the key into the lock
- Press down the pillion
- Release the key
- Press down the pillion once more, so to make sure of its firm coupling to the frame.

4

**WARNING**

Every time you lift or remove the pillion and every time the vehicle is used, make sure that the above mentioned part is correctly placed and that it is firmly secured to the motorcycle framework.



4.7. Parking the motorcycle

□ Using the sidestand



CAUTION

Park the motorcycle safely on solid ground. On slopes, engage the first gear and park the vehicle so that the front wheel faces uphill. Remember to put the gear lever in the neutral position before restarting the engine. Never leave the vehicle unattended while the engine key is in the dashboard.

- ▶ Using your foot, lower the sidestand as far as it will go, and then slowly tip the motorcycle toward you to bring the stand supporting foot into contact with the ground's surface.





□ Using the rear stand

Insert the stand pin into the rear wheel axle hole on the left side of the motorcycle. Rest the stand on the ground and, pressing down on the stand, lift the vehicle until it reaches a stable condition.



CAUTION

This operation is best carried out with two people, one to steady the motorcycle and one to manipulate the rear stand.

4

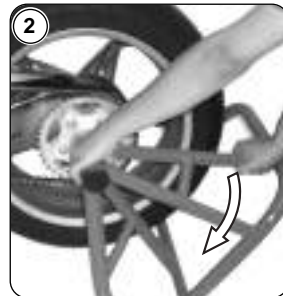
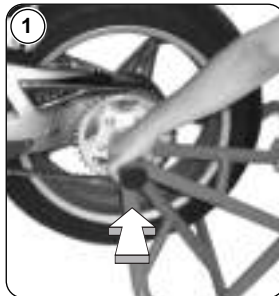



4.8. Preriding checks



WARNING

A motorcycle can be in good running order and then become unexpectedly unreliable even if unused (e.g. deflation of the tyres). It is therefore important to carry out the checks described in the table below before each ride. A few moments taken to carry out these checks will help you maintain your motorcycle safe and in perfect working order.

Brakes

Check fluid level (§6.7).
Check for fluid leakage.
Pull lever and press pedal to check brake operation.
Lubricate the lever joint, if necessary.
Check pads for wear (§6.6).

Gear lever

Press pedal to check gear operation.
Lubricate the lever joint, if necessary.

Clutch lever

Check fluid level (§6.8).
Check for fluid leakage.

Pull lever and check that it moves smoothly and gradually.
Lubricate the lever joint, if necessary.

Engine start button / stop switch

Check operation (§3.4).

Throttle twist grip

Check that grip rotates smoothly and returns to closed position when released.

Steering system

Verify that the operation is smooth and uniform.
Check for play and loosening.

Lights, visual and acoustic signals

Check operation.

Tyres

Check inflating pressure and wear (§6.9).

Suspensions

Verify that the operation is smooth and uniform.
Check adjustment (§5.6 and 5.7).

Frame fasteners

Check tightening of all screws and nuts.
Tighten them, if necessary.

Drive chain

Check adjustment and lubrication (§6.10).

Coolant

Check level (§6.5).
Check for leakage.

**Fuel**

Check level.

Refuel, if necessary (§4.5).

Check for fuel leakage.

Engine oil

Check level (§6.4).

Check for leakage.

Sidestand

Check return to stowed position.

Verify that the safety switch is working.

Pillion

Verify that the pillion is firmly secured to the framework.

**WARNING**

If any of the above-mentioned parts shows a failure during its operation, have it controlled and repaired before using the motorcycle.



4.9. Riding

Riding a motorcycle requires experience and concentration.

Inexperienced riders should undergo a period of training and attend an introductory course consisting of theoretical lessons as well as practical riding sessions in areas closed to traffic.

The instructor's advice will help the novice rider become familiar with the basics of riding safety.

Relying on the advice of persons other than a qualified riding instructor, even if possessing specific knowledge, may prove to be useless or even dangerous, especially if the practical training takes place in an area open to traffic.

**WARNING**

While riding, always observe the safety prescriptions described in paragraph 2.1.8. of this manual.



5.1. List of adjustments

There are many adjustments that can significantly improve the ergonomics, geometry and safety of the motorcycle.

Some of these can only be performed by skilled personnel at authorized service centres.



WARNING

To avoid losing control of the vehicle while riding, be sure to always keep both hands on the handlebars. All adjustments must be performed when the vehicle is stationary.



(E) Rearview mirror adjustment (§5.5.)

(A) Front brake lever adjustment (§5.3.)

(G) Rear suspension adjustment (§5.7.)

(D) Rear brake lever adjustment (§5.2.)

(F) Front suspension adjustment (§5.6.)

(F) Front suspension adjustment (§5.6.)

(L) Headlight adjustment (§5.8.)

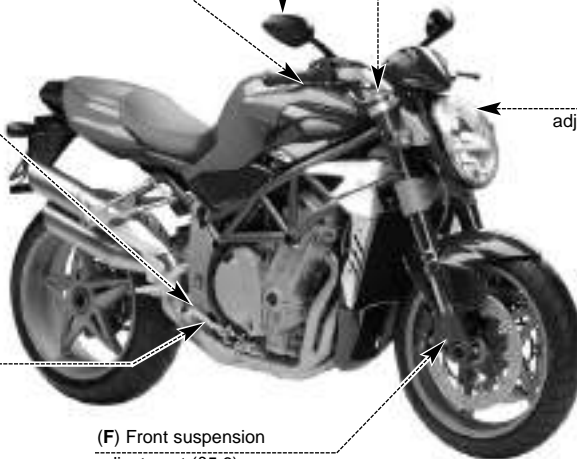



(E) Rearview mirror adjustment (§5.5.)

(B) Clutch lever adjustment
(§5.4.)

(C) Gear lever
adjustment (§5.2.)

(G) Rear suspension adjustment (§5.7.)

(H) Drive chain
adjustment (§6.10.)





5.2. Table of adjustments

	A - Front brake lever adjustment: Optimizes the grip to suit the rider's needs (§5.3).	
	B - Clutch lever adjustment: Optimizes the grip to suit the rider's needs (§5.4).	
	C - Gear lever adjustment: Optimizes the position of the lever to suit the rider's needs.	
	D - Rear brake lever adjustment: Optimizes the position of the lever to suit the rider's needs.	
	E - Rearview mirror adjustment: Optimizes the orientation of the rearview mirrors (§5.5).	
	 WARNING Do not operate the screw fixing the rearview mirror to the handlebar. If this screw needs to be tightened, contact your MV Agusta dealer.	
		F - Front suspension adjustment: The following can be adjusted to adapt the response of the suspension to the rider's preference: <ul style="list-style-type: none">- spring preload (§5.6.1.)- rebound damper (§5.6.2.)- compression damper (§5.6.3.)
		G - Rear suspension adjustment: The following can be adjusted to adapt the response of the suspension to the rider's preference: <ul style="list-style-type: none">- spring preload- geometry height- rebound damper (§5.7.1.)- high speed compression damper (§5.7.2.)- low speed compression damper (§5.7.3.)
		H - Drive chain adjustment: To ensure safe and effective transmission of power.
		L - Headlight adjustment: To adjust the range of the light beam to the geometry of the motorcycle (§5.8).



5.3. Adjusting the front brake lever



WARNING

Never perform the adjustment while riding.

While pulling the lever to counter the action of the spring, turn the ring clockwise or counterclockwise to move the lever away or towards the handgrip respectively.



5.4. Adjusting the clutch lever



WARNING

Never perform the adjustment while riding.

While pulling the lever to counter the action of the spring, turn the ring clockwise or counterclockwise to move the lever away or towards the handgrip respectively.





5.5. Adjusting the rearview mirrors

**WARNING**

Never perform the adjustment while riding.

Press the mirror at the points shown in the figure to adjust its position in the four directions. Perform the adjustment on both the rearview mirrors. It is recommended to sit on the vehicle in order to optimize the rearview mirrors adjustment.



WARNING: Check the rearview mirrors adjustment every time you use your motorcycle.



5



5.6. Adjusting the front suspension



WARNING

It is essential that the adjusters of both fork rods are adjusted to the same position.

Rebound damper

Spring preload

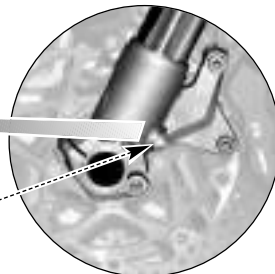
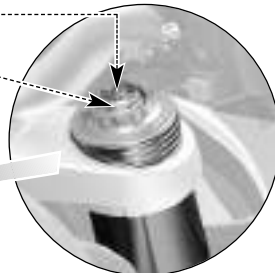

Compression damper



5.6.1. Spring preload

The adjustment is obtained from the standard position, which is found by fully turning the adjusting nut counterclockwise and then clockwise (see enclosed table). Rotate clockwise to increase the spring preload or counterclockwise to decrease it.



5.6.2. Rebound damper (front suspension)

The adjustment is obtained from the standard position, which is found by fully turning the screw clockwise and then counterclockwise (see enclosed table). Rotate clockwise to increase the damping action or counterclockwise to decrease it.





5.6.3. Compression damper (front suspension)

The adjustment is obtained from the standard position, which is found by fully turning the screw clockwise and then counterclockwise (see enclosed table). Rotate clockwise to increase the damping action or counterclockwise to decrease it.

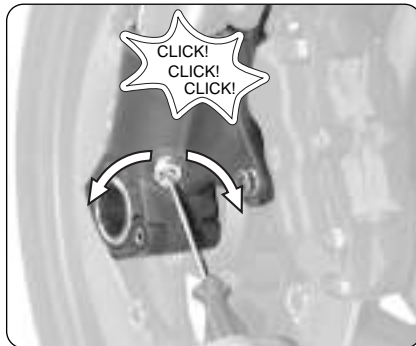



5.7. Adjusting the rear suspension



WARNING

The high temperature of the exhaust pipes can cause burns. Before adjusting the rear suspension, shut off the engine and wait until the exhaust pipes have thoroughly cooled.

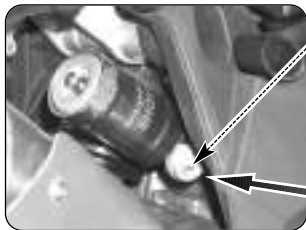

High and Low speed
compression damper

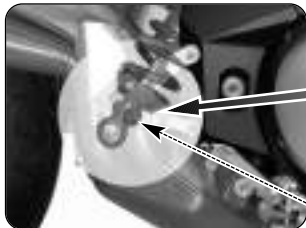

Rebound damper





5.7.1. Rebound damper (rear suspension)

The adjustment can be performed by operating on the screw placed on the lower side of the shock absorber, and it is obtained from the standard position.

This position is found by fully rotating the ring clockwise and then counterclockwise (see enclosed table). Rotate clockwise to increase the damping action or counterclockwise to decrease it.

5





5.7.2. High speed compression damper (rear suspension)

The adjustment can be performed by operating on the ring nut placed on the upper side of the shock absorber, and it is obtained from the standard position. This position is found by fully rotating the ring nut counterclockwise and then clockwise (see enclosed table). Rotate clockwise to increase the damping action or counterclockwise to decrease it.



5.7.3. Low speed compression damper (rear suspension)

The adjustment can be performed by operating on the screw placed on the upper side of the shock absorber, and it is obtained from the standard position. This position is found by fully rotating the screw clockwise and then counterclockwise (see enclosed table). Rotate clockwise to increase the damping action or counterclockwise to decrease it.





5.8. Headlight adjustment

Place the vehicle at a distance of 10 m from a vertical wall.

Make sure that the motorcycle is placed on an even horizontal surface, and that the headlight's optical axis is perpendicular to the wall.

The vehicle must be held in an upright position. Measure the "X" distance between the headlight center and the ground surface, then trace a small cross on the wall at the same height.

When you turn the headlight on, the upper boundary line between the dark area and the lighted area must be at an height equal or lower than the 9/10 of the headlight center height (X).

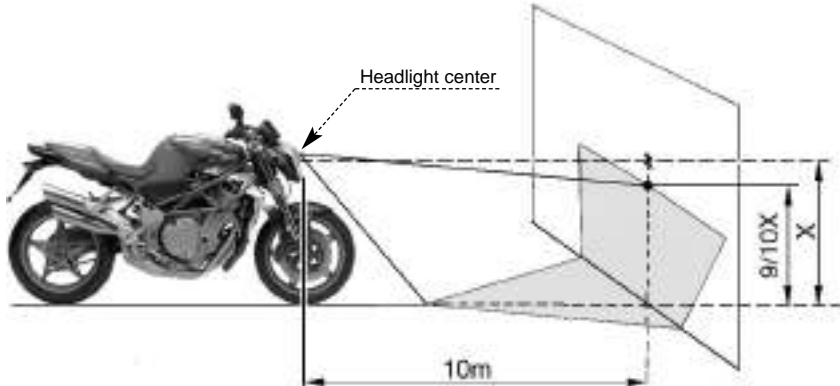



The headlight adjustment can be performed by rotating the screw shown in the picture. Rotate clockwise to incline the headlight downwards, counterclockwise to incline it upwards. The possible adjustment range is equal to $\pm 4^\circ$ from the standard position.

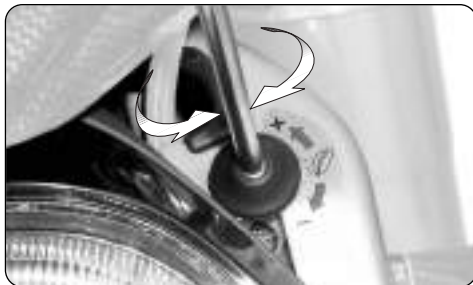
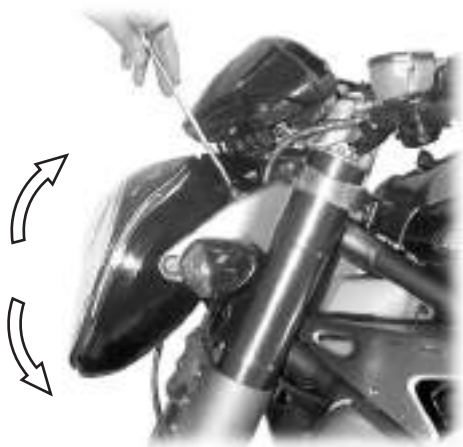

5



6.1. Tables of scheduled maintenance and checks

The main periodic checks and maintenance operations are shown in the following tables. These operations are necessary to keep the motorcycle safe and in perfect running order.

The intervals indicated in the periodic maintenance and lubrication tables must be intended as a general guide under normal riding conditions. It could be necessary to reduce these intervals according to the climate, the ground conditions, the geographic position and the conditions of use.

Some of the operations can be carried out by the user, providing he or she possesses the requisite skills. If unskilled, have the operations performed by an authorized service centre.

6

As a rule maintenance operations must be performed while the motorcycle is on the rear stand after switching off the engine and setting the start switch to OFF. On the contrary, while checking the fluid levels it is advisable to keep the motorcycle in an upright position without using the rear stand.

After the first 36,000 km (22,400 mi) the operations must be performed at the same intervals shown in the tables.

**WARNING**

- Improperly or lack of recommended maintenance operations can lead to an increase of the risk of accidents and damage to the motorcycle.
- Always use genuine MV Agusta spare parts. Using non-genuine spare parts can accelerate the wear of your motorcycle and shorten its life.
- Failure to perform the recommended operations, as well as using non-genuine spare parts, makes the warranty null and void.

**WARNING**

If your motorcycle is involved in an accident, have all its main parts controlled by an authorized MV Agusta dealer. If necessary, you can make some provisional repairs by yourself.

**WARNING**

To replace or top up the lubricants and fluids of your motorcycle, use only the products given at paragraph 6.3.

**Respect and defend natural environment**

Everything we do affects the whole planet as well as its resources.

MV Agusta, in order to protect the interests of the community, awakens the Customers and the Technical Assistance operators to use the vehicle and dispose of its replaced parts respecting the laws in force concerning environmental pollution and waste disposal and recycling.











Tables of scheduled maintenance

km (mi) covered		0	1000 (600)	6000 (3800)	12000 (7500)	18000 (11200)	24000 (14900)	30000 (18600)	36000 (22400)
Service coupon		Pre-delivery	A	B	C	D	E	F	G
DESCRIPTION		OPERATION							
Engine oil		Check level	Every time vehicle is used						
		Renew	●	●	●	●	●	●	●
Engine oil filter		Replace (Use only MV Agusta genuine spare oil filters)	●	●	●	●	●	●	●
			Every time engine oil is changed						
Coolant		Check / Restore level	Every time vehicle is used						
		Check / Restore level	●	●	●	●	●	●	●
		Renew	At least every two years						
Cooling system		Check for leakage	●	●	●	●	●	●	●
Electric fans		Check operation	●	●	●	●	●	●	●
Valves		Check / Adjust		●		●		●	
Timing chain		Check		●		●		●	
		Replace							●















Tables of scheduled maintenance

km (mi) covered		0	1000 (600)	6000 (3800)	12000 (7500)	18000 (11200)	24000 (14900)	30000 (18600)	36000 (22400)	
Service coupon		Pre-delivery	A	B	C	D	E	F	G	
DESCRIPTION		OPERATION								
Timing movable shoe		Check / Replace	●		●		●			
		Replace							●	
Every time timing chain is replaced										
Timing chain stretcher		Check / Replace			●		●		●	
Spark plugs		Check / Replace	●	●		●		●		
		Replace			●		●		●	
Fuel filter		Check / Replace			●		●		●	
Throttle body 		Check and Adjust	●	●	●	●	●	●	●	
Air filter		Check / Replace		●	●	●	●	●	●	
Brakes / Clutch fluid		Check level	Every time vehicle is used							
		Check level	●	●	●	●	●		●	●
		Renew						●		
At least every two years										



Tables of scheduled maintenance

km (mi) covered		0	1000 (600)	6000 (3800)	12000 (7500)	18000 (11200)	24000 (14900)	30000 (18600)	36000 (22400)
Service coupon		Pre-delivery	A	B	C	D	E	F	G
DESCRIPTION		OPERATION							
Brakes / Clutch	 Check operation	Every time vehicle is used							
	 Clean lever / master cyl. piston contact area	Every 500 ÷ 1000 km (300 ÷ 600 mi)							
	 Check operation	●	●	●	●	●	●	●	●
	 Check lines for leakage	●	●	●	●	●	●	●	●
Brake pads (front and rear)	 Clean lever / master cyl. piston contact area	●	●	●	●	●	●	●	●
	 Check wear	Every 1000 km (600 mi)							
	 Check / Replace		●	●	●	●	●	●	●
Fuel lines and connections	 Check for leakage		●	●	●	●	●	●	●
	 Replace	At least every 3 years							
Throttle control	 Check operation	Every time vehicle is used							
	 Check operation	●	●	●	●	●	●	●	●
	 Check / Adjust play	●	●	●	●	●	●	●	●
Choke control	 Check operation	●	●	●	●	●	●	●	●













Tables of scheduled maintenance

km (mi) covered		0	1000 (600)	6000 (3800)	12000 (7500)	18000 (11200)	24000 (14900)	30000 (18600)	36000 (22400)	
Service coupon		Pre-delivery	A	B	C	D	E	F	G	
DESCRIPTION		OPERATION								
Flexible controls and transmissions		Check / Adjust	●	●	●	●	●	●	●	
Drive chain		Check	Every 1000 Km (600 mi)							
		Lubricate	Every 1000 Km (600 mi) and after riding under the rain							
	Check / Adjust	●	●	●	●	●	●	●	●	
	Lubricate		●	●		●		●		
	Replace				●		●		●	
Front sprocket / Tab washer		Check		●	●		●		●	
		Replace				●		●	●	
		Every time drive chain is replaced								
Rear sprocket		Check		●	●		●		●	
		Replace				●		●	●	
		Every time drive chain is replaced								



Tables of scheduled maintenance

km (mi) covered		0	1000 (600)	6000 (3800)	12000 (7500)	18000 (11200)	24000 (14900)	30000 (18600)	36000 (22400)	
Service coupon		Pre-delivery	A	B	C	D	E	F	G	
DESCRIPTION		OPERATION								
Rear sprocket spring drive		Check			●		●		●	
Steering head tube ring 		Check / Adjust	●		●		●		●	
Steering bearings 		Check / Adjust	●		●		●		●	
		Lubricate					●			
Tyres		Check pressure	Every time vehicle is used; at least every 10 days							
		Check wear	Every time vehicle is used; at least every 500 Km (300 mi)							
		Check pressure	●	●	●	●	●	●	●	●
		Check wear		●	●	●	●	●	●	●
Wheel rims		Inspect visually	●	●	●	●	●	●	●	
			Every time tyre is replaced							
Front wheel bearings 		Check		●	●	●	●	●		
		Every time tyre is replaced								
		Replace								●



Tables of scheduled maintenance

km (mi) covered		0	1000 (600)	6000 (3800)	12000 (7500)	18000 (11200)	24000 (14900)	30000 (18600)	36000 (22400)
Service coupon		Pre-delivery	A	B	C	D	E	F	G
DESCRIPTION		OPERATION							
Sidestand		Check operation							
		Every time vehicle is used							
Side stand switch		Check operation							
		Clean contact area with sidestand							
		Every 500 ÷ 1000 km (300 ÷ 600 mi)							
		●	●	●	●	●	●	●	●
Rear wheel hub		Check / Lubricate needle bearing			●		●		
		Replace / Lubricate needle bearing							●
Swingarm bearings		Check / Lubricate							●
Drive chain pads on swingarm		Check / Replace		●	●	●	●	●	●
Drive chain pads on frame plate		Check / Replace		●	●	●	●	●	●
Rear shock absorber		Check / Adjust		●	●		●		●
Front fork oil		Renew					●		









Tables of scheduled maintenance

km (mi) covered		0	1000 (600)	6000 (3800)	12000 (7500)	18000 (11200)	24000 (14900)	30000 (18600)	36000 (22400)
Service coupon		Pre-delivery	A	B	C	D	E	F	G
DESCRIPTION		OPERATION							
Battery connections		Check and clean	●	●	●	●	●	●	●
Electrical equipment		Check operation	●	●	●	●	●	●	●
Instrument panel		Check operation	Every time vehicle is used						
		Check operation	●	●	●	●	●	●	●
Lights / Visual signals		Check operation	Every time vehicle is used						
		Check operation	●	●	●	●	●	●	●
Horn		Check operation	Every time vehicle is used						
		Check operation	●	●	●	●	●	●	●
Headlight		Check operation	Every time vehicle is used						
		Check operation	●	●	●	●	●	●	●
		Adjust	Every time geometry is changed						
Ignition switch		Check operation	Every time vehicle is used						
		Check operation	●	●	●	●	●	●	●



Tables of scheduled maintenance

km (mi) covered		0	1000 (600)	6000 (3800)	12000 (7500)	18000 (11200)	24000 (14900)	30000 (18600)	36000 (22400)	
Service coupon		Pre-delivery	A	B	C	D	E	F	G	
DESCRIPTION		OPERATION								
Locks		Check operation	Every time vehicle is used							
		Check operation	●	●	●	●	●	●	●	●
Screws and nuts		Check / Tighten	●	●	●	●	●	●	●	●
Hose clamps 		Check / Tighten	●	●	●	●	●	●	●	●
General lubrication			●	●	●	●	●	●	●	●
General test			●	●	●	●	●	●	●	●

In order to highlight symbols importance, remember the following information (already provided at § 1.2 of this manual):



Information on operations that can be carried out by the user.



Information on operations that ***must*** be performed ***only*** by your authorized MV Agusta dealer.



The “” symbol points out the requirement to use a tool or a special equipment in order to correctly perform the described operation.



The “§” symbol refers the reader to the chapter identified by the number that follows.



6.2. Tools and accessories supplied

A bag in the glove compartment contains the following tools:

- 1 hexagonal bar (10 mm hexagon);
- 6 Allen keys (2,5 - 3 - 4 - 5 - 6 - 8 mm hexagons);
- 1 spanner for rear wheel eccentric with extension;
- 2 fuses (7.5 A and 15 A).

The following accessories are also supplied:

- 1 spark plug wrench (16 mm hexagon);
- 1 document holder.





6.3. Table of lubricants and fluids

<i>Description</i>	<i>Recommended product</i>	<i>Specifications</i>
Engine lubrication oil	AGIP RACING 4T 10W/60 (*)	SAE 10W/60 - API SJ
Coolant	AGIP ECO - PERMANENT	Ethylene glycol diluted with 40 percent distilled water
Brake and clutch fluid	AGIP BRAKE FLUID DOT4	DOT4
Drive chain lubrication oil	MOTUL CHAIN LUBE PLUS	-

* : MV Agusta suggests to refer directly to its authorized dealers in order to purchase the recommended product. The AGIP Racing 4T 10W/60 engine oil has been expressly produced for the F4 motorcycle engine. If the above described lubricant is not available, MV Agusta suggests to use a fully synthetic engine oil having characteristics equal or better than the ones prescribed in the following standards:

- Consistent with: API SJ
- Consistent with: ACEA A3
- Consistent with: JASO MA
- SAE Rating: SAE 20 W-50 or 10 W-60

NOTE

The above standard denominations must be written, alone or together, on the engine oil container label.





6.4. Checking the engine oil level

Check the oil level while the engine is not running, and has been allowed to cool down for at least ten minutes after a ride.

The check must be performed after placing the motorcycle in an upright position on a horizontal surface.

The level must be between the MAX and MIN marks on the crankcase.

If the oil level is below the MIN mark, top up as described in § 6.4.1.

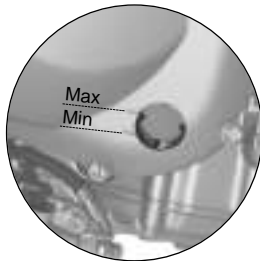

6



WARNING

Do not start the engine if the oil level is below the MIN mark.



6.4.1. Topping up the engine oil level

To top up the engine oil level, remove the oil filler plug and pour an appropriate amount of engine oil of the recommended type. Never exceed the MAX level mark. At the end of the operation, place back the oil filler plug.



CAUTION

To avoid clutch sliding and damage to the engine, never add chemical additives to the engine oil, nor use an engine oil different from the one specified in the table at § 6.3. Make sure that no foreign body gets in the crankcase while topping up the engine oil.

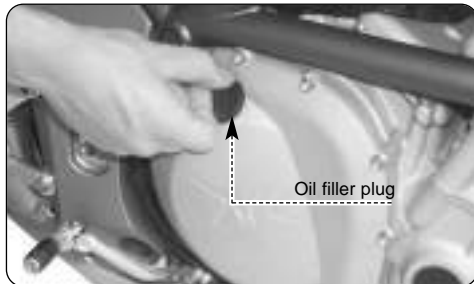

**WARNING**

New or exhaust engine oil can be dangerous. Engine oil is highly toxic for people and domestic animals. Avoid ingestion and contact. It has been proved that prolonged contact with engine oil can cause skin cancer on guinea pigs. Even a brief contact with engine oil can cause skin irritation.

- In the event of an engine oil ingestion, immediately call a doctor and do not cause vomiting, in order to avoid inhalation of engine oil in lungs.

- Keep new or exhaust engine oil out of reach of children and domestic animals.
- While topping up the engine oil, wear a long-sleeved shirt and a pair of waterproof gloves to protect your skin.
- If the engine oil comes in touch with your skin, wash it away with soap and water.
- Correctly recycle or dispose of the exhaust engine oil, in order to avoid environmental pollution.



6.5. Checking the coolant level

Check the coolant level while the engine is off and cold.

The check must be performed after placing the motorcycle in an upright position on a horizontal surface.

Ensure that the coolant level is between the MIN mark and the lower side of the frame tube as shown in the figure.

If the coolant level is below the MIN mark, top up the coolant as described at paragraph 6.5.1.



WARNING

Do not start the engine if the coolant level is below the MIN mark.

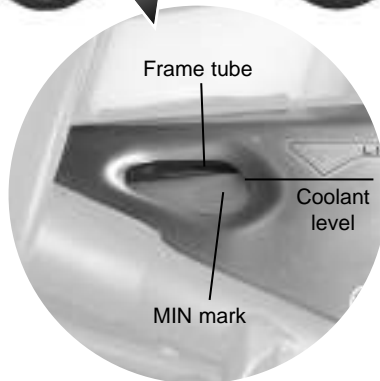



6.5.1. Topping up the coolant level

To gain access to the coolant filler cap, extract the cover after by removing its fixing screws. Remove the coolant filler cap and top up with the recommended coolant (see §6.3).

Coolant filler cap

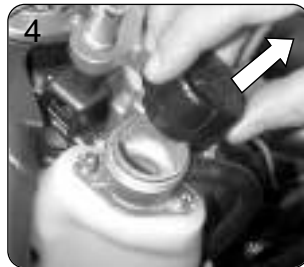
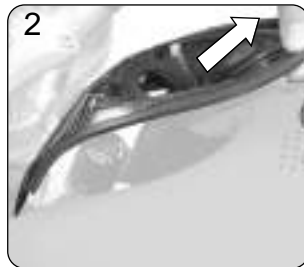
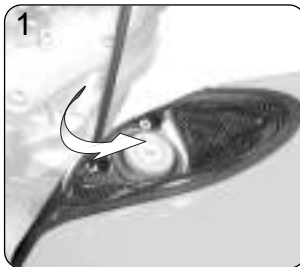

After topping up, carefully replace the previously removed parts.



WARNING: Perform the topping up of the coolant when the engine is off and cold. Never attempt to remove the coolant filler cap when the engine is hot, in order to avoid the risk of burns. The cooling system is under pressure!



CAUTION: To top up the coolant level and/or renew the coolant, use only the product specified in the table in section 6.3. Do not mix nor dilute the coolant with additives or different fluids. If the coolant specified in section 6.3. is not available, use a coolant having technical characteristics consistent with the prescribed product.



CAUTION: Coolant can damage painted and plastic parts. When you top up the coolant level, be careful not to spill coolant on any part of the motorcycle. If you do spill coolant on your motorcycle, immediately wipe it away using a clean cloth.

**WARNING**

Under certain conditions, ethylene glycol contained in the coolant can become flammable. When it is lighted, it produces an invisible flame.

Avoid spilling coolant on hot parts of the motorcycle, because the subsequent combustion of ethylene glycol could cause serious burns.

**WARNING**

Coolant is a highly toxic fluid. Avoid ingestion and contact with your skin or eyes. Keep coolant out of reach of children and domestic animals. In the event of a coolant ingestion, immediately call a doctor and do not cause vomiting, in order to avoid inhalation of coolant in lungs. If the coolant comes in touch with your skin or eyes, immediately wash it away with water.

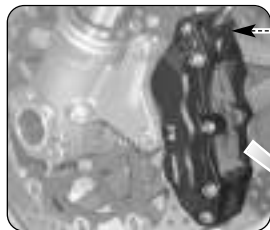

Front brake caliper



Rear brake caliper

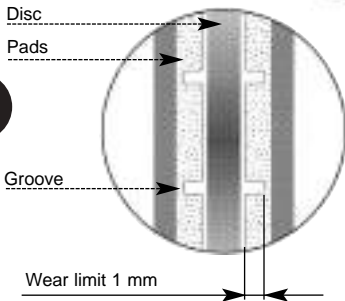

6.6. Checking the wear of the brake pads

The brake pads have grooves that provide an indication of the wear condition. Periodically check the width of the grooves, making sure it never falls below the wear limit (1 mm).



WARNING: If the brake pads are excessively worn out, the effectiveness of the braking system decreases, increasing the risk of accidents. If the pads have worn to near the wear limit, have both pads replaced by an authorized service centre. Ensure that the new pads are suitably broken in (see § 4.2).



Rear brake fluid reservoir

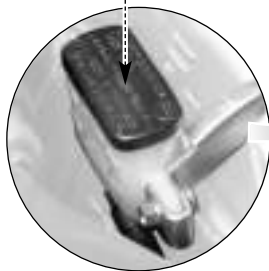

Front brake fluid reservoir

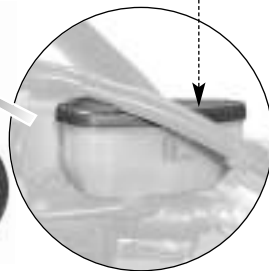

6.7. Checking the brake fluid level



WARNING

Lack of maintenance of the braking system can increase the risk of accidents. Before riding, always check the braking system according to the instructions provided at § 4.9. of this manual.

The level of the brake fluid decreases as the brake pads wear down. Ensure that the fluid level is always between the MAX and MIN marks. If the level falls below the MIN mark, contact an authorized service centre and have the brake system overhauled.

**WARNING**

Never use your motorcycle if the fluid level is below the MIN mark. The brakes may fail to properly operate, which could lead to an accident. If the brake fluid level is below the MIN mark, you must have it topped up by an authorized MV Agusta dealer.

**WARNING**

Have the topping up of the brake fluid performed only by skilled personnel. Brake fluid is highly toxic. Avoid ingestion and contact with your skin or eyes. Keep brake fluid out of reach of children and domestic animals. In the event of a brake fluid ingestion, immediately call a doctor and do not cause vomiting, in order to avoid inhalation of brake fluid in lungs. If the brake fluid comes in touch with your skin or eyes, immediately wash with water.

**WARNING**

Use only the brake fluid specified at paragraph 6.3. of this manual. Mixing different brake fluids can cause a dangerous chemical reaction, as well as the decrease of the braking efficiency, with subsequent increase of the risk of accidents.

**WARNING**

An insufficient amount of brake fluid may allow the introduction of air in the braking system. This could compromise the effectiveness of the braking system, with subsequent increase of the risk of accidents. Presence of air in the braking system can be identified in the moment you feel a characteristic “spongy effect” while pushing the brake pedal. In this case, have a braking system bleeding performed by an authorized MV Agusta dealer before riding your motorcycle again.



6.8. Checking the clutch fluid level

The fluid level must be between the MAX and MIN marks.

If the level falls below the MIN mark, contact an authorized service centre and have the clutch control system repaired.

**WARNING**

Never use your motorcycle if the fluid level is below the MIN mark. The clutch may fail to properly operate, which could lead to an accident. If the clutch fluid level is below the MIN mark, have it topped up by an authorized MV Agusta dealer.

**WARNING**

Use only the clutch fluid specified in the paragraph 6.3. of this manual.





6.9. Checking and replacing the tyres



WARNING

Before using the motorcycle, always check the pressure and wear of the tyres.

Checking the inflating pressure of the tyres is an essential requirement to ensure driving safety. Insufficiently inflated tyres can reduce the handling of the motorcycle and wear themselves out very quickly. On the other hand, an excessively high inflating pressure reduces the wideness of the surface in contact with the ground, and it can compromise the grip of the vehicle.

Before riding your motorcycle, it is therefore necessary to measure the tyre pressure at room temperature. The vehicle must be parked since three hours at least.



WARNING

An incorrect inflating pressure can lead to dangerous situations during riding. An insufficiently inflated tyre can cause the sliding of the tyre on the wheel rim or its detachment; this may lead to the deflation of the tyre with subsequent loss of control of the vehicle.



In fact, by checking the pressure soon afterwards using the motorcycle, you would obtain a higher value than the actual one. This could cause an incorrect adjustment of the tyre pressure.

Refer to the pressures given in § 8.2. and/or on the label applied to the steering head tube. In the event of long travels, you can increase the face value of the tyre pressure of 0.2 bar.

Moreover, it is extremely important to check the wear of the tyres before riding. In fact, a worn out tyre can be punctured more easily than a new one, and it can adversely affect handling and stability of the motorcycle.

Check that the depth of the tyre tread is not below the values prescribed by the Highway Code.

Verify the absence of crevices at the bottom of the tread design and fissures on the tyre sidewall. Moreover, verify the absence of nails and glass splinters in the tyre. If these conditions are not verified, have the tyre replaced by an authorized MV Agusta dealer.

**WARNING**

The limits of the tyre tread depth may vary from country to country. Always refer to the values prescribed by the law provisions of the nation in which you use your motorcycle.

**WARNING**

- If the tyres of your motorcycle are excessively worn out, have it replaced by your MV Agusta dealer. Besides being illegal, riding a motorcycle with excessively worn out tyres can reduce its stability and lead to the loss of control of the vehicle.

- If a tyre is punctured it must be replaced, not repaired. A repaired tyre provides a restricted performance and lower safety levels than a new one. If you make a provisional or emergency repair to a tyre, you must ride at very low speed until you reach the nearest



MV Agusta dealer and have the tyre replaced. With a provisionally repaired tyre, never exceed 60 km/h. Tyre repairing must never be performed if the tyre is punctured on its sidewall, or if the diameter of the puncture on the tread is greater than 6 mm.

- MV Agusta recommends not to use sealing fluids to repair a punctured tyre. These products can adversely affect the material of the tyre layers, as well as hide the minor damages caused by objects penetrated in the tyre.
- When it is necessary to replace the tyres, use only the type specified in paragraph 8.2. Moreover, avoid using tyres of a different brand or type on the front and on the rear wheel at the same time. Using tyres different from those specified can adversely affect the handling and stability of the motorcycle, increasing the risk of accidents.
- The wheel rims of your motorcycle

have been designed for use with tubeless tyres only. Do not assemble an air tube tyre on rims designed for tubeless tyres. Otherwise, the tyre bead could not properly settle down on the wheel rim, leading to the deflation of the tyre and the loss of control of the vehicle.

- Do not assemble an air tube on a tubeless tyre. The overheating of the tyre could cause the explosion of the air tube, leading to the deflation of the tyre and the loss of control of the vehicle.
- Have the tyres replaced according to their direction of spin, which is highlighted by a small arrow on the tyre sidewall.
- New tyres should be run in for a short period before demanding their full performance. In fact, during this period the tyres could have a reduced grip on some kind of roads. We suggest to ride at reduced speed and exercise extreme caution during the first 100 km after the replacement of a tyre.



❑ Rear wheel disassembling



CAUTION

If you have the rear wheel tyre replaced by a tyre-dealer, make sure that the following tools are used in the rear wheel disassembling and reassembling:

- 55 mm polygonal socket wrench
- Torque wrench

If the above mentioned operations are performed with tools other than those indicated, the rear wheel parts can be seriously damaged. Therefore, we strongly recommend not to have the tyres replaced by an improperly equipped workshop. Always have the tyres replaced by an authorized MV Agusta dealer.

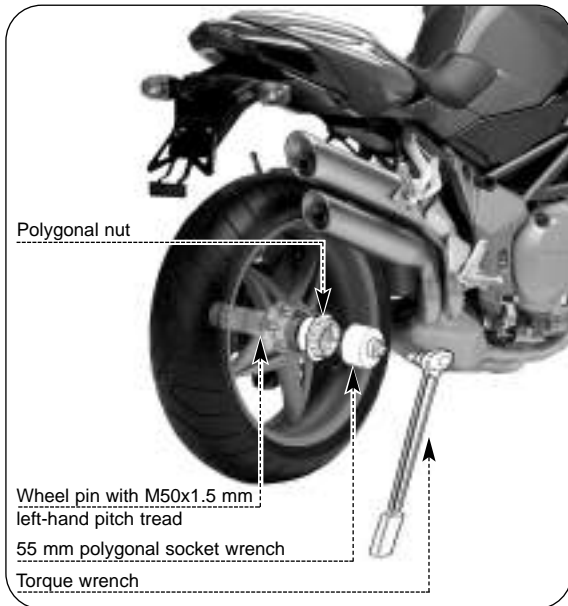



□ Checking the wheel rims

Before riding, always verify the absence of cracks, bending or buckling on the wheel rims.



WARNING

If you find that the wheel rim is damaged, have it replaced by an authorized MV Agusta dealer. Never attempt to repair the wheel rim, even in case of slight damage.

Every time you replace a tyre or a rim, you must have a wheel balancing performed by an authorized MV Agusta dealer. Wheel unbalance can adversely affect performance and handling of the motorcycle, as well as shorten the life of the tyres.



WARNING

When you have a wheel balancing performed, make sure to assemble only approved counterweights on the wheel rim. MV Agusta recommends not to use balancing or balancing/sealing fluids.



WARNING

Do not attempt to have a tubeless tyre removed without using the proper tools and protections for the wheel rim. Otherwise, you could damage the sealing surface of the rim, leading to the deflation of the tyre and the loss of control of the vehicle.



6.10. Checking and lubricating the drive chain

To perform these operations, you must put the motorcycle on the rear stand, upright on a horizontal surface and with the gear in neutral.

❑ Checking the chain adjustment

The axis of the chain lower portion must be **11 mm** from the lower chain guard. Manually turn the rear wheel and carry out the check at several points along the chain. The distance between the chain and the lower chain guard must remain constant as the wheel turns. If the chain is only partially loosened, it means that some chain links are flattened or seized. If the distance is greater than 11 mm, have the chain adjusted by your local MV Agusta dealer.

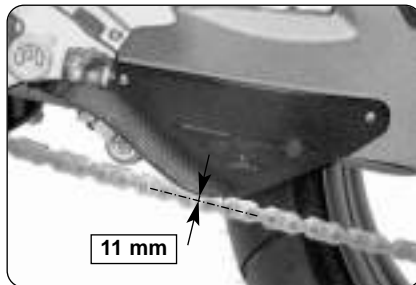

**WARNING**

Riding your motorcycle when the drive chain is in poor condition or improperly adjusted can lead to accidents. Before riding, always check the chain adjustment according to the procedures shown in this paragraph. If necessary, have the chain adjusted by your MV Agusta dealer.

**WARNING**

If any chain link is flattened or seized, you must correctly lubricate the chain according to the procedures shown in the following paragraph.

**WARNING**

If you notice damage or excessive wear of the chain and the related sprockets, have them replaced by an authorized MV Agusta dealer. Every time the chain is replaced, you must always replace the front and rear sprockets too.

**WARNING**

Using a chain with a fake link can be dangerous. An uncompletely riveted or fake link can accidentally split open and cause accidents, as well as damage to the engine. Never use a chain with a fake link.

**WARNING**

Every time it is requested to operate the rear wheel hub screws, contact an authorized MV Agusta dealer. In order to tighten the screws, apply a tightening torque equal to the value shown in the label placed on the swingarm (see paragraph §2.2.). Applying a torque higher than the indicated value can cause the fast decay of the rear wheel hub, compromising the reliability of the vehicle and the safety of the pilot and the passenger.



❑ Lubrication

To ensure proper operation, the drive chain needs to be properly lubricated.

▶ Preliminary cleaning - Before lubrication, the dirt accumulated on the chain must be dissolved using kerosene. The dirt must then be removed with a clean rag and/or an air jet.



CAUTION

The chain is of the O-ring type. To prevent it from damaging, never clean the chain with a steam or high pressure water jet, nor using gasoline or other solvents. The chain must be cleaned using kerosene only.



WARNING

Kerosene is highly toxic and flammable. Avoid contact and inhalation. Keep kerosene away from sparks and flames. Keep kerosene out of reach of children and domestic animals. Correctly dispose of exhaust kerosene, in order to avoid environmental pollution.





► **Lubrication** - Apply a slight and uniform film of lubricant over the whole length of the drive chain, taking care not to smear the surrounding parts, and in particular the tyres.



CAUTION

Only use the lubricant specified in the paragraph 6.3. of this manual, in order to protect the drive chain and avoid oil spurts when the vehicle is in motion.



WARNING

Chain lubrication must be performed according to the intervals specified in the tables of scheduled maintenance (see § 6.1.). It is also necessary to perform this operation after riding under the rain and after cleaning the motorcycle. Riding your motorcycle when the drive chain is in poor condition or improperly adjusted can lead to accidents.





6.11. Checking the idle speed

Check the idle speed when the engine has reached the operating temperature. Ensure that the choke control has not been activated.

The idle speed should range from 1,050 to 1,250 rpm.









If a tune-up is necessary, contact an authorized service centre.





6.12. Replacing parts - General information

The replacement of the fuses (except for the battery recharge fuse) and the light bulbs can be carried out by the owner according to the indications provided below.

	Battery recharge fuse - Replacement (§6.12.1.)
	Service fuses - Replacement (§6.12.1.)
	Low beam bulb - Replacement (§6.12.2.)
	High beam bulb - Replacement (§6.12.3.)
	Front parking light bulb - Replacement (§6.12.4.)
	Front turn indicator bulbs - Replacement (§6.12.5.)
	Rear turn indicator bulbs - Replacement (§6.12.6.)
	Rear light and brake light bulb - Replacement (§6.12.7.)
	License plate light bulb - Replacement (§6.12.8.)

6.13.1. Replacing the fuses

► The recharge fuse is located under the driver's saddle, in the position shown in the figure.

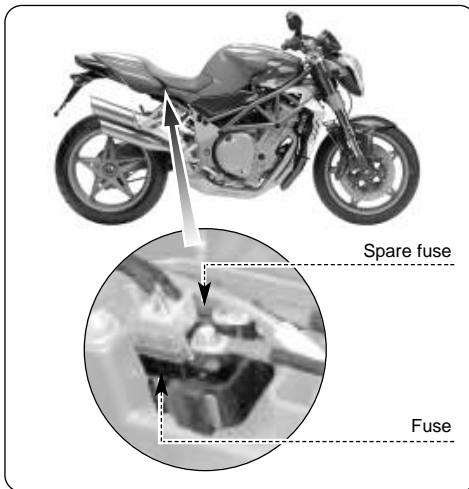



► The service fuses are located on the right side. To expose them, remove the right hand fuel tank side fairing.



► Remove the cover.



CAUTION

Turn the ignition key on the “OFF” position before checking or replacing the fuses, in order to avoid a short circuit with subsequent damage to other electric parts of the motorcycle.





► To identify the position and function of the fuses, refer to the information shown on the adhesive label and in the enclosed electrical diagram. The reference letters in the figure correspond to those shown in the diagram.

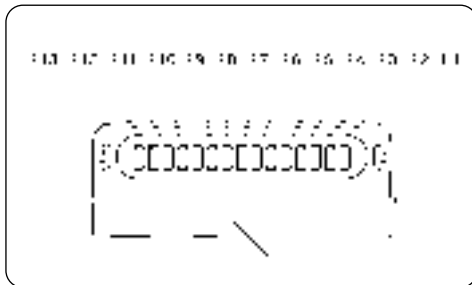

► Replace the blown fuse and refit the cover. Remember that the tool bag contains two spare fuses.

6



WARNING

Never replace a fuse with a rating other than that prescribed, in order to avoid damage to the electrical equipment of the motorcycle which could lead to a fire.





6.12.2. Replacing the low beam bulb

► Remove the headlight lateral fixing screws. Pay attention in slipping off the adjuster from its seat when the headlight is being removed from its support.



- Before removing the headlight from its support, detach the connector on the rear side of the headlight.
- Lay down the headlight on a table, in order to perform the following operations.





- ▶ Remove the headlight rear screw.
- ▶ Remove the front part of the headlight from its supporting shell.
- ▶ Detach the low beam bulb connector.
- ▶ Remove the protective cap.
- ▶ Release the retaining spring.
- ▶ Extract the burnt-out low beam bulb.



CAUTION: Do not touch the bulb glass with bare hands. If you do, clean the bulb with an oil-free solvent.

- ▶ Insert the new bulb.
- ▶ Reattach the spring.
- ▶ Replace the bulb protective cap.
- ▶ Reattach the low beam bulb connector.
- ▶ Replace the front part of the headlight on its supporting shell.
- ▶ Replace the headlight rear screw.
- ▶ Reattach the headlight connector.
- ▶ Replace the headlight on its support and insert the two lateral fixing screws, making sure to insert the adjuster in its proper seat on the headlight.





6.12.3. Replacing the high beam bulb

- ▶ Remove the headlight from its support as described in paragraph 6.12.2.
- ▶ Extract the high beam bulb by rotating it counter-clockwise.
- ▶ Detach the connector from the burnt-out bulb.



CAUTION: Do not touch the bulb glass with bare hands. If you do, clean the bulb with an oil-free solvent.

- ▶ Insert the connector in the new bulb.
- ▶ Insert and lock the bulb holder in place by rotating clockwise.
- ▶ Replace the headlight on its support, following the instructions described in paragraph 6.12.2.





6.12.4. Replacing the front parking light bulb

- ▶ Remove the headlight from its support as described in paragraph 6.12.2.
- ▶ Extract the front parking light bulb holder by rotating it counterclockwise.
- ▶ Pull out the burnt-out bulb.



CAUTION: Do not touch the bulb glass with bare hands. If you do, clean the bulb with an oil-free solvent.

- ▶ Insert the new bulb.
- ▶ Insert and lock the bulb holder in place by rotating clockwise.
- ▶ Replace the headlight on its support, following the instructions described in paragraph 6.12.2.





6.12.5. Replacing the front turn indicator bulbs

- ▶ Remove the fixing screw.
 - ▶ Remove the lens.
-
- ▶ To remove the burnt-out bulb, press it and rotate it counterclockwise.
 - ▶ To fit the new bulb, press it and rotate it clockwise.
 - ▶ Replace the lens and insert the fixing screw.





6.12.6. Replacing the rear turn indicator bulbs

- ▶ Remove the fixing screw.
 - ▶ Remove the lens.
-
- ▶ To remove the burnt-out bulb, press it and rotate it counterclockwise.
 - ▶ To fit the new bulb, press it and rotate it clockwise.
 - ▶ Replace the lens and insert the fixing screw.





6.12.7. Replacing the rear light and brake light bulb

- ▶ Lift the pillion (§4.6.).
- ▶ Remove the bulb holder by turning it counterclockwise.



- ▶ To remove the bulb, press it and rotate it counterclockwise.
- ▶ To fit the new bulb, press it and rotate it clockwise.
- ▶ Replace the bulb holder and lock it in place by rotating it clockwise.





6.12.8. Replacing the license plate light bulb

▶ Remove the cable rail fixing screws.



▶ Pull down the cable rail and detach it from the upper surface, operating as described in the picture.





- ▶ Pull out the license plate light bulb holder.
- ▶ Extraxt the burnt-out bulb.
- ▶ Fit the new bulb.
- ▶ Replace the bulb holder.
- ▶ Push back the cable rail in touch with the upper surface.
- ▶ Replace the cable rail fixing screws.





6.13. Battery

The battery is of the maintenance-free type and is installed under the tail section. This battery does not require checking of the fluid level or adding of distilled water.

If the battery seems to be run-down (causing electrical problems or a difficult starting), have it recharged by an authorized MV Agusta dealer as soon as possible. Remember that the battery runs down more quickly if your motorcycle is equipped with additive electrical accessories.



WARNING

If the battery casing is damaged, there may be a leakage of sulphuric acid, a **HIGHLY TOXIC AND CORROSIVE** substance. Avoid any contact with your eyes, skin and clothes. Always wear protective glasses when you have to work near the battery.

In the event of a contact with sulphuric acid, give the FIRST AID as described below:

- **CONTACT WITH EYES:** Wash away with water for about 15 minutes, and immediately call a doctor.
- **CONTACT WITH SKIN:** Wash away with a great amount of water.
- **INGESTION:** Drink great amounts of water or milk, and immediately call a doctor.

Furthermore, leakage of sulphuric acid can result in the formation of hydrogen gas which, if ignited by a spark or a flame, would cause an explosion. Always have the battery replaced by your local MV Agusta dealer.



Prolonged inactivity

If the motorcycle is to remain unused for a long time (a month or longer), it is advisable to disconnect the battery cables or have the battery removed by skilled personnel. In case of prolonged inactivity, to avoid shortening the life of the battery, it is essential to have it recharged by your MV Agusta dealer every 4-5 months.



WARNING: The inversion of the battery wires can damage the battery and the recharging system. The red wires must be connected to the positive terminal (+), while the black wires must be connected to the negative terminal (-).

When removing the battery, disconnect the negative terminal FIRST and then the positive terminal. When reinstalling the battery, use the reverse procedure.





6.14. Cleaning the motorcycle

Periodic careful cleaning is a key factor in preserving the value of the motorcycle, protecting its surface finish and checking for damages, wear and leakage of corrosive fluids.



CAUTION

Before washing the vehicle, stop up the exhaust pipes and protect the electrical parts.



WARNING

Do not wash your motorcycle soon afterwards riding. Attend a few minutes to allow the engine and the exhaust pipes to thoroughly cool.



CAUTION: Never use washing systems involving steam or high pressure water jets. These systems could cause water infiltration and damage the internal parts of your motorcycle.



INFORMATION: Spilling detergent can cause environmental pollution. Therefore, you should clean your motorcycle in an area equipped for collection and disposal of washing fluids.



Wash the motorcycle with water, a mild detergent and a sponge. Wipe the vehicle with a soft cloth. Use an air jet to dry difficult-to-reach areas.

**CAUTION**

- **Avoid using clothes or sponges that have been in contact with strong or abrasive detergents, solvents or gasoline.**
- **To avoid irreparable damage to the bodywork parts, never use alkaline or strongly acid detergents, petrol, brake fluid or other solvents.**

Periodically treat the paintwork with high quality wax. After riding on roads treated with corrosive substances (salt), wash the vehicle as soon as possible with cold water. Do not use hot water as it enhances the corrosive action.

**WARNING**

Avoid smearing brakes or tyres with oil or wax. If necessary, clean the brake discs with a brake disc detergent or with acetone, and wash the tyres with warm water and a neutral detergent.

**WARNING**

The presence of water on the brakes can lead to a decrease of the braking effectiveness with subsequent risk of accidents. After completing the washing, run the engine for a few minutes and start off at reduced speed. Carefully apply the brakes a few times so as to dry the brake pads and discs.

**WARNING**

The drive chain must be correctly lubricated after washing the motorcycle, following the instructions provided at § 6.10. of this manual.

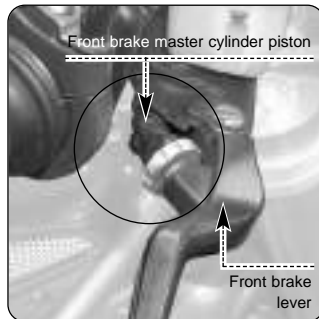
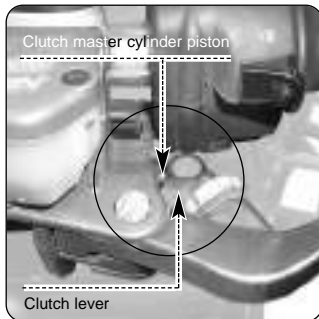
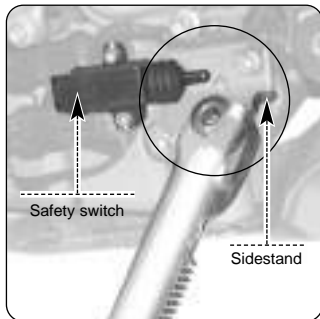

CAUTION

Make sure to always keep clean the contact areas between the following components, as shown in the above figures:

- Side stand and safety switch
- Clutch lever and clutch master cylinder piston
- Front brake lever and front brake master cylinder piston

Clean these areas every 500 ÷ 1000 km, as prescribed in the Scheduled Maintenance Table. In any case, we suggest to verify the cleanliness of the above areas every time you use the vehicle, in order to maintain the related parts in good working order.

**6.15. Prolonged inactivity**

If the motorcycle is to remain unused for a long time, it is advisable to carry out the following operations:

	Empty the fuel tank.
	Remove the battery and store it in a suitable place.
	Remove the spark plug caps and the spark plugs. Pour a teaspoonful of engine oil in every spark plug hole, then place back the spark plugs and the corresponding caps. Make the engine run idle for a few times.
	Lubricate all control cables and the joints of all pedals and levers.
	Clean the motorcycle and treat the paintwork with high quality wax (§6.14.).
	In order to ensure integrity and performance of the tyres, park your motorcycle in a fresh, dry and dark place, with a temperature relatively constant and lower than 25° C. Avoid direct contact of the tyres with heating pipes or radiators, and prolonged contact with oil or gasoline. Avoid parking with the tyres near to electrical motors or devices capable to produce sparks or electric discharge. During the period of inactivity, place your motorcycle on the rear stand (§4.7).
	Cover the vehicle with an adequate canvas cover.

When the motorcycle is first put back into service, remember to carry out a comprehensive check (§4.8.) and, if necessary, to have the vehicle serviced (§6.1.).



7.1. Engine problems: **ENGINE DOES NOT START**

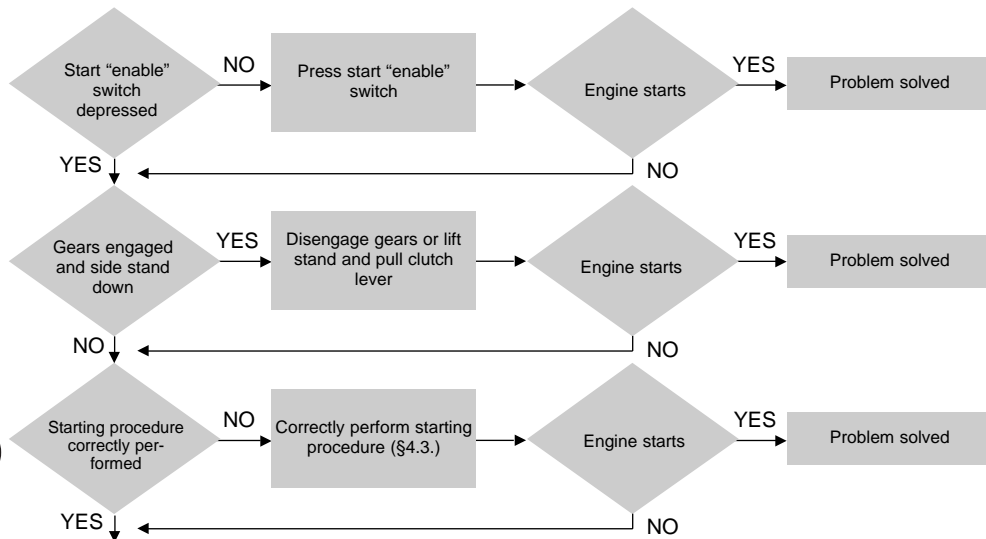

continued on next page



continued from previous page

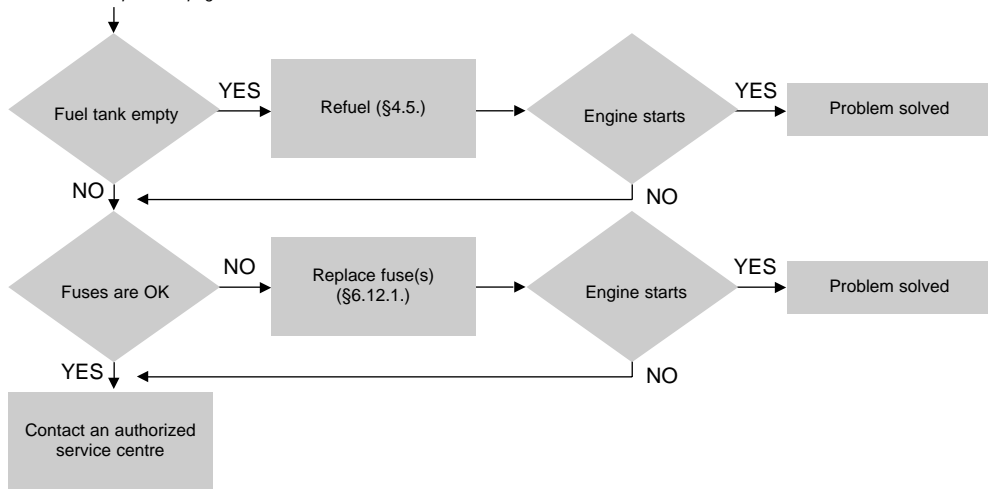



ENGINE IS DIFFICULT TO START

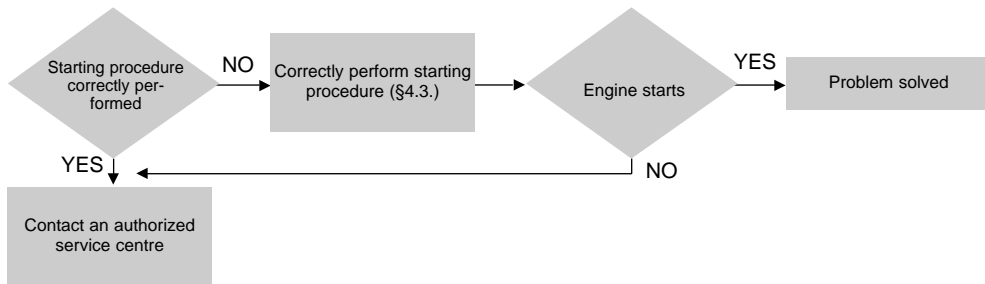



ENGINE OVERHEATS

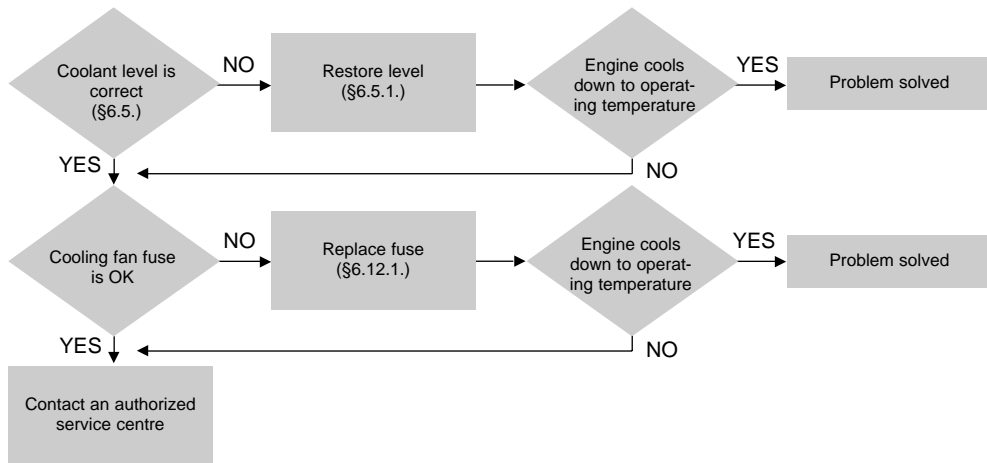

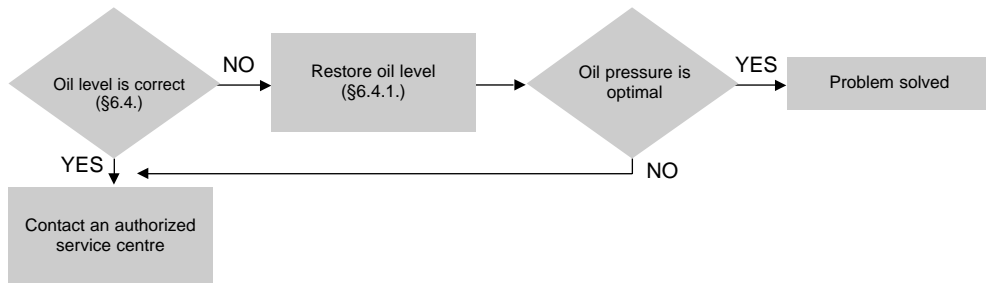
**OIL PRESSURE IS TOO LOW**



7.2. Electrical equipment problems: **LIGHTS DO NOT WORK**

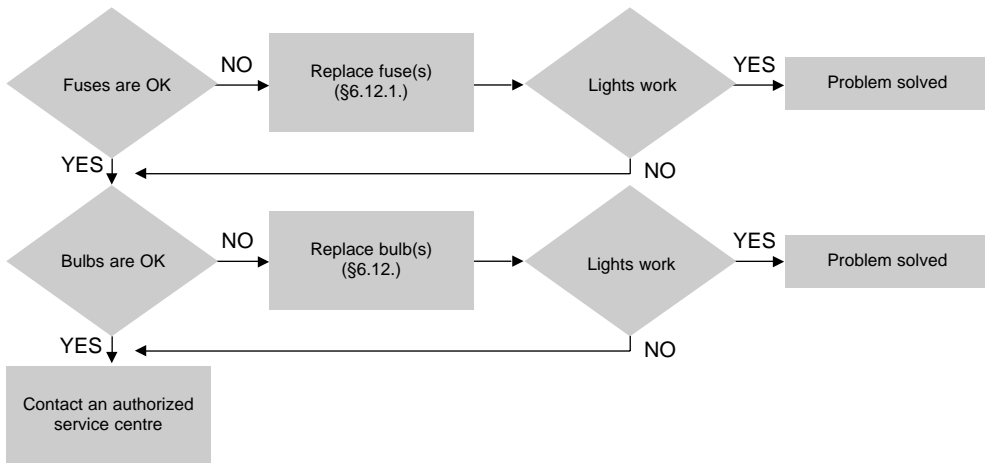



HORN DOES NOT WORK

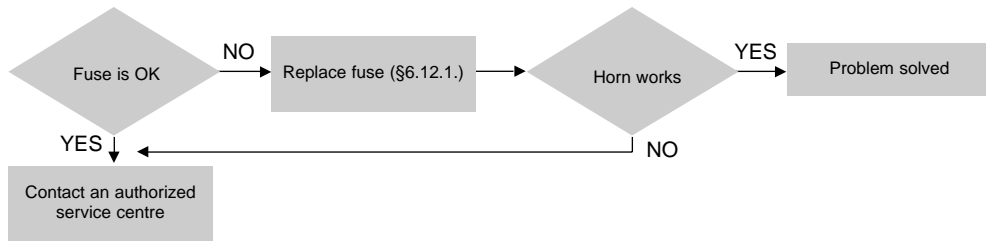

SPEEDOMETER DOES NOT WORK

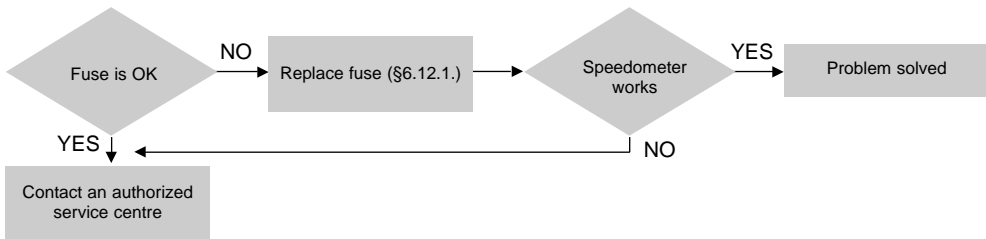



RESERVE FUEL WARNING LIGHT DOES NOT WORK

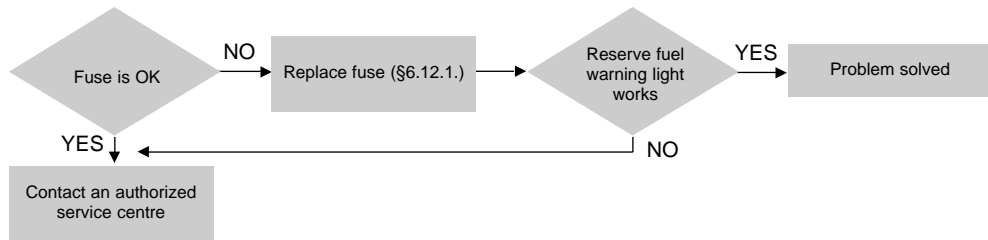

ALTERNATOR DOES NOT CHARGE BATTERY

Contact an authorized service centre



8.1. Motorcycle overview

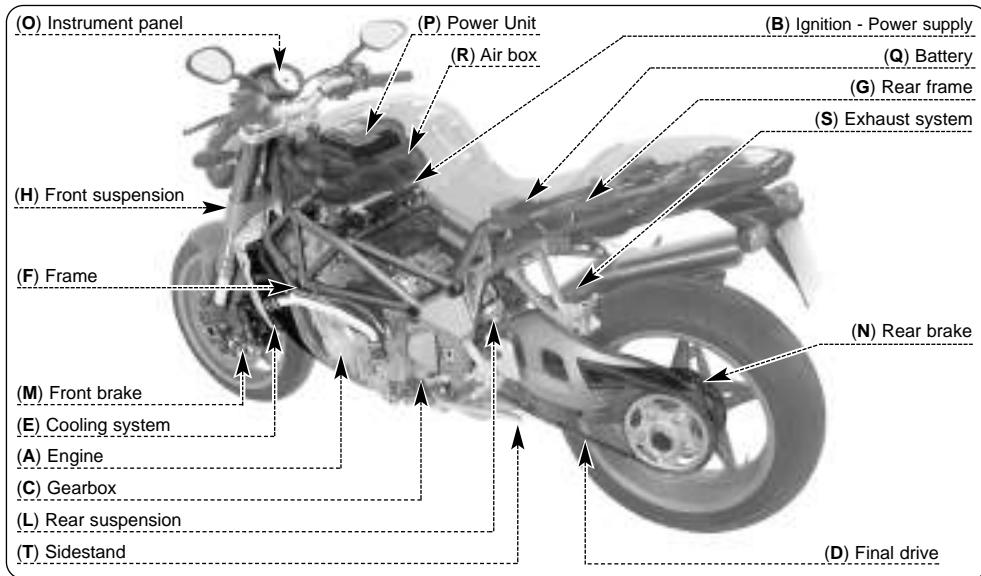



- A - Engine:** four-stroke, inline four-cylinder. Double-overhead camshaft valve train with radial valves. Wet sump lubrication.
- B - Ignition - Power supply:** integrated ignition-injection system. Inductive-discharge electronic ignition. "Multipoint" electronic injection.
- C - Gearbox:** removable, six-speed, with constant-mesh gears.
- D - Final drive:** consisting of drive sprocket, rear sprocket and chain.
- E - Cooling system:** liquid cooling with water-oil heat exchanger.
- F - Frame:** tubular steel trellis with aluminium (magnesium ★) side plates.
- G - Rear frame:** tubular steel trellis.
- H - Front suspension:** upside-down hydraulic fork with external adjusting system.
- L - Rear suspension:** progressive, with single-sided swingarm and single shock absorber with external adjusting system.
- M - Front brake:** dual semi-floating disc with six-piston calipers.
- N - Rear brake:** single disc with four-piston caliper.
- O - Instrument panel:** with warning lights and analogue and digital instruments.
- P - Power unit:** equipped with EPROM for the electronic control of the integrated ignition-injection system.
- Q - Battery:** sealed and maintenance-free.
- R - Air box:** equipped with filtering system of the engine intake air flow.
- S - Exhaust system:** equipped with catalytic converter for exhaust emission reduction.
- T - Sidestand:** equipped with safety switch and dual return spring.



8.1.1 Front brake circuit

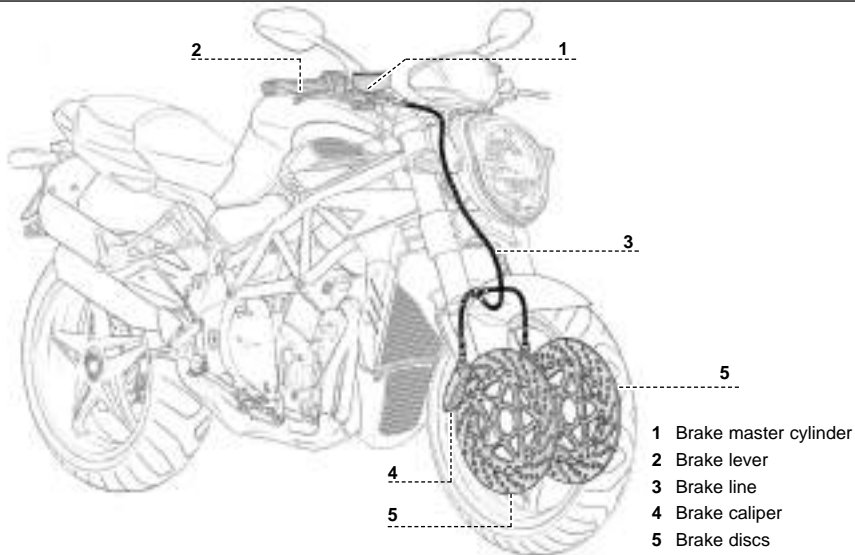



8.1.2. Rear brake circuit

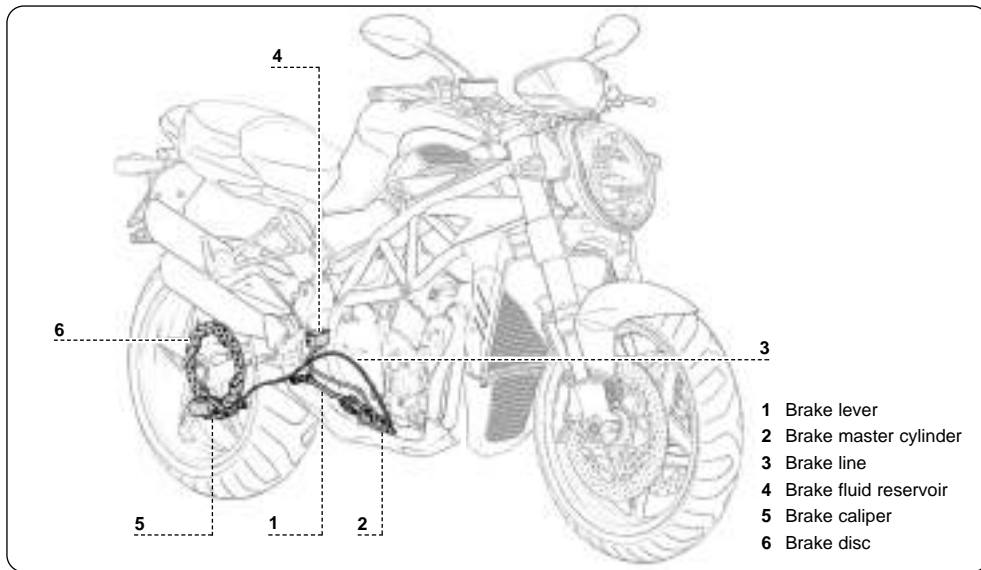



8.1.3. Clutch circuit

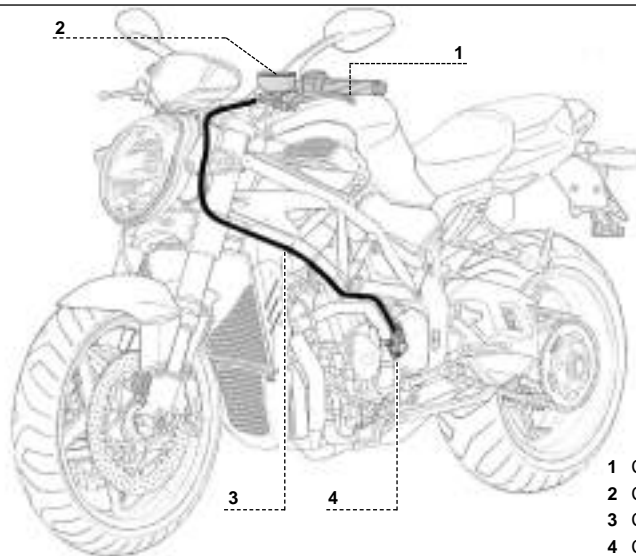

- 1 Clutch lever
- 2 Clutch master cylinder
- 3 Clutch line
- 4 Clutch cylinder assembly



8.1.4. Engine lubrication

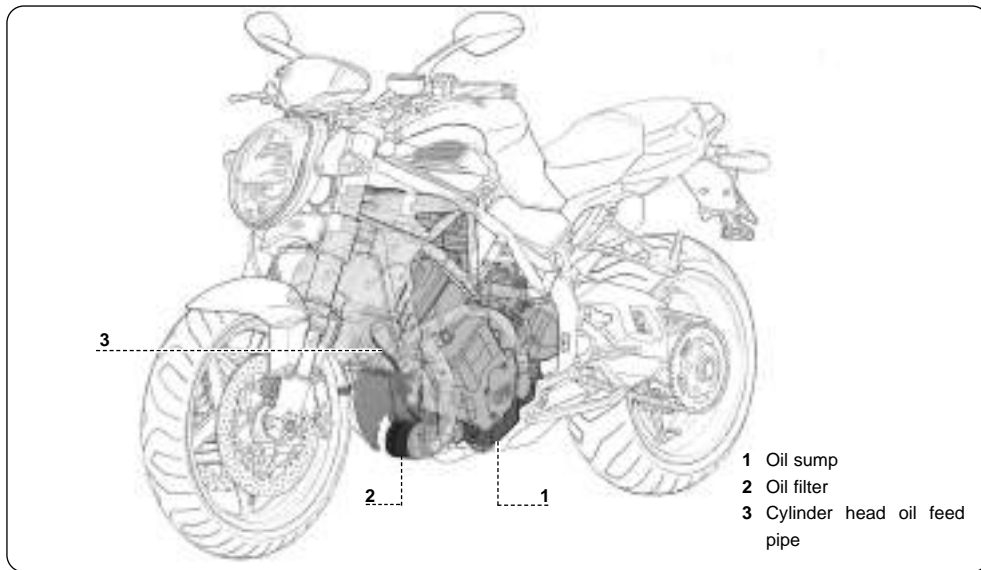



8.1.5. Coolant circuit

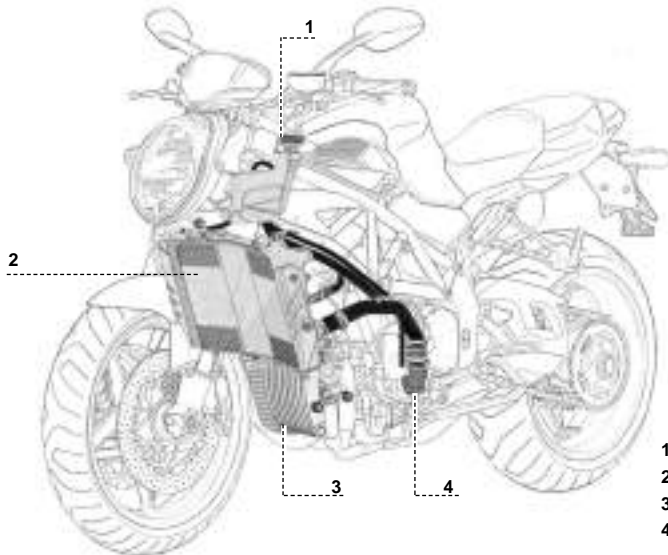

- 1 Expansion tank
- 2 Upper radiator
- 3 Lower radiator
- 4 Coolant pump



8.1.6. Fuel system

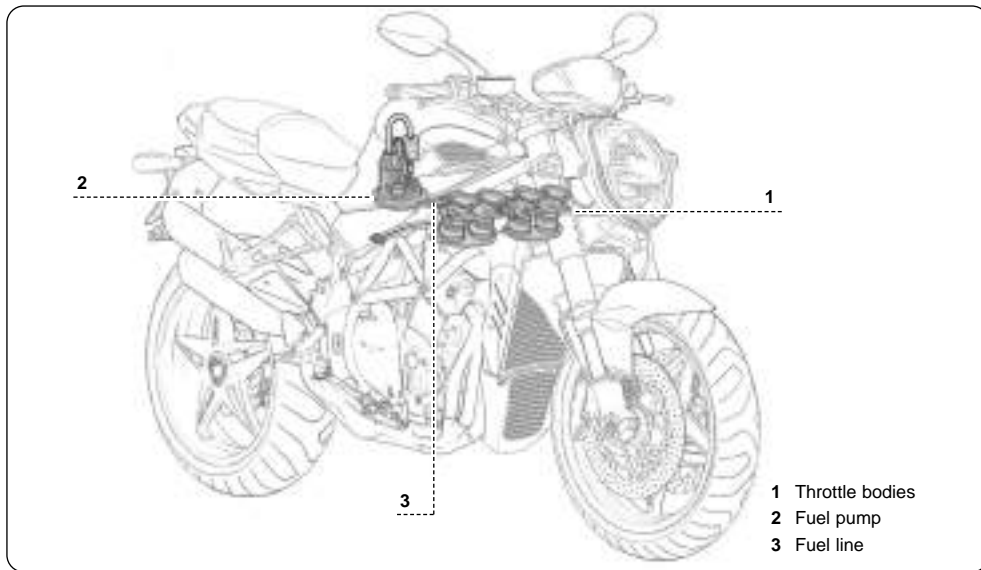

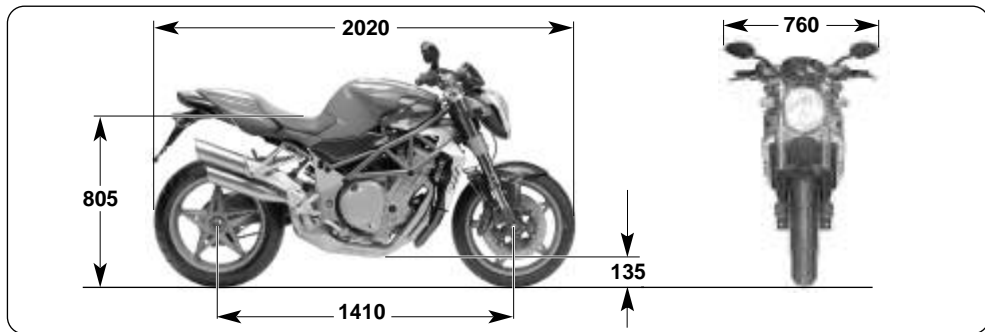

8.2. Specifications

Description	BRUTALE S
SPECIFICATIONS	
Wheelbase (mm) (*)	1410
Overall length (mm) (*)	2020
Max. width (mm)	760
Seat height (mm) (*)	805
Min. ground clearance (mm) (*)	135
Trail (mm) (*)	101,5

* : The indicated values must not be intended as binding informations. They can change according to the vehicle setup.



Specifications

Description	BRUTALE S
Dry weight (Kg)	185
Fuel tank capacity (lt) (*)	19
Reserve fuel (lt) (*)	4
Oil in crankcase (Kg)	3,5
ENGINE	
Type	Four-cylinder, four-stroke, 16 valves
Bore (mm)	73,8
Stroke (mm)	43,8
Total displacement (cm ³)	749,4
Compression ratio	12 : 1
Starting	Electric starter
Cooling system	Liquid cooling with water-oil heat exchanger
Crankcase and covers	Die-cast
Head and cylinders	Chill-cast
Valves	Bimetal / single-metal
VALVE TRAIN	
Type	Double-overhead camshaft, radial valves

* : The indicated data must not be intended as binding informations. They can change according to the environmental temperature, the engine temperature and the evaporation point of the gasoline.

**Specifications**

Description	BRUTALE S	
LUBRICATION		
Type	Wet sump	
IGNITION - POWER SUPPLY		
Type	"Weber-Marelli" 1.6 M integrated ignition-injection system Inductive discharge electronic ignition, "Multipoint" electronic injection	
Spark plugs	NGK CR9 EB	Champion G59c
Spark gap (mm)	0.7 ÷ 0.8	0.6 ÷ 0.7
CLUTCH		
Type	Multiple-disc in oil bath	
PRIMARY DRIVE		
Number of teeth on crankshaft gear	Z = 47	
Number of teeth on clutch gear	Z = 81	
Transmission ratio	1.72	
SECONDARY DRIVE		
Number of teeth on front sprocket	Z = 14	
Number of teeth on rear sprocket	Z = 41	
Transmission ratio	2.93	
TRANSMISSION		
Type	Removable, six-speed gearbox with constant-mesh gears	



Specifications

Description	BRUTALE S
Gear ratio (overall ratios)	
First gear	2.92 (14.71)
Second gear	2.21 (11.14)
Third gear	1.78 (8.97)
Fourth gear	1.50 (7.56)
Fifth gear	1.32 (6.65)
Sixth gear	1.21 (6.10)
FRAME	
Type	CrMo steel tubular trellis (TIG welded)
Swingarm pivot plates	Aluminium alloy
FRONT SUSPENSION	
Type	“Upside down” telescopic hydraulic fork with external adjustment of rebound and compression damping and of spring preload
Rod diameter (mm)	50
Travel on leg axis (mm)	126
REAR SUSPENSION	
Type	Progressive, single shock absorber with rebound and compression (High speed / Low speed) damping and spring preload adjustment
Swingarm	Aluminium alloy
Wheel travel (mm)	120



Specifications

Description	BRUTALE S
FRONT BRAKE	
Type	Dual floating disc with steel braking band
Disc diameter (mm)	310
Disc flange	Steel
Calipers, piston diameters (mm)	6-piston Ø 22.65; Ø 25.4; Ø 30.23
REAR BRAKE	
Type	Single steel disc
Disc diameter (mm)	210
Caliper, piston diameter (mm)	4-piston, Ø 25.4
FRONT RIM	
Material	Aluminium alloy
Dimensions	3.50" x 17"
REAR RIM	
Material	Aluminium alloy
Dimensions	6.00" x 17"
TYRES	
Front	120/65-ZR 17 (56 W) or 120/70-ZR 17 (56 W-58 W)
Rear	180/55-ZR 17 (73 W) or 190/50-ZR 17 (73 W)



Specifications

Description	BRUTALE S
Brand and type	MICHELIN Pilot Power DUNLOP - Sport Max D 208 Race Replica
Inflating pressure (*):	
Front	2.3 bar (33 psi)
Rear	2.3 bar (33 psi)
ELECTRICAL EQUIPMENT	
Equipment voltage	12V
Low beam	12V 55W
High beam	12V 60W
Front parking light	12V 5W
Rear light	12V 5W
Brake light	12V 21W
Turn indicators	12V 10W
Battery	12V - 9Ah
Alternator	650W at 5000 rpm
BODYWORK	
Fuel tank	Thermoplastic material
Air scoops	Thermoplastic material

* : If you use tyres of a brand different from the ones recommended, refer to the inflating pressure values marked by the manufacturer on the tyre sidewall.



Specifications

Description	BRUTALE S
Fuel tank side panels	Thermoplastic material
Tail piece side panels	Thermoplastic material
Tail piece	Thermoplastic material
Dashboard cover	Thermoplastic material
Ignition switch cover	Thermoplastic material
Front mudguard	Thermoplastic material
Chain guards	Thermoplastic material
Oil cooler guard	Thermoplastic material
License-plate holder	Thermoplastic material
Rearview mirrors	Thermoplastic material
Exhaust pipe guard	Aluminium



8.3. Accessories

MV Agusta, through **MV AGUSTA Corse**, has designed a wide range of accessories, kit and special parts to customize or increase the performances of your motorcycle. This way, **MV Agusta** provides you the chance to develop your motorcycle, taking advantage of the excellence and the exclusiveness of innovatory technical solutions with the quality warranty provided by CRC technical department of research and development. Both frame and bodywork spare parts designed by Cagiva Research Center for MV Agusta Corse have undergone severe tests and rigorous checks, in order to offer to the Customers the same official warranty as all MV Agusta products.

In order to request these components or consult the MV Agusta Corse Catalogue, we suggest to refer to:



MV Agusta Corse S.r.l. - Sales and Technical Assistance Service

Via Ovella 41 - 47893 Borgo Maggiore - Republic of San Marino (R.S.M.)

Phone number: (00378) 0549 907.749 - Fax number: (00378) 0549 907.746

e-mail: info@mvagustacorse.com - <http://www.mvagustacorse.com>

MV Agusta strongly recommends not to use non-genuine components, since they cannot offer the same safety, vehicle performance and life duration as original and certified spare parts.



8.4. Clothing

MV AGUSTA Corse has designed a wide range of wear products and accessories providing high aesthetical and qualitative standards, helping to strenghten and consolidate the prestige of the MV Agusta trademark and, at the same time, making an exclusive experience out of riding an already unique vehicle.





NOTES

.....

.....

.....

.....

.....

.....

.....

.....

.....

.....

.....

.....

.....

.....

.....

.....

.....



NOTES

.....

.....

.....

.....

.....

.....

.....

.....

.....

.....

.....

.....

.....

.....

.....

.....

.....

.....

.....

.....

.....

.....



NOTES

.....

.....

.....

.....

.....

.....

.....

.....

.....

.....

.....

.....

.....

.....

.....

.....

.....

.....

.....

.....

.....

.....



NOTES

.....

.....

.....

.....

.....

.....

.....

.....

.....

.....

.....

.....

.....

.....

.....

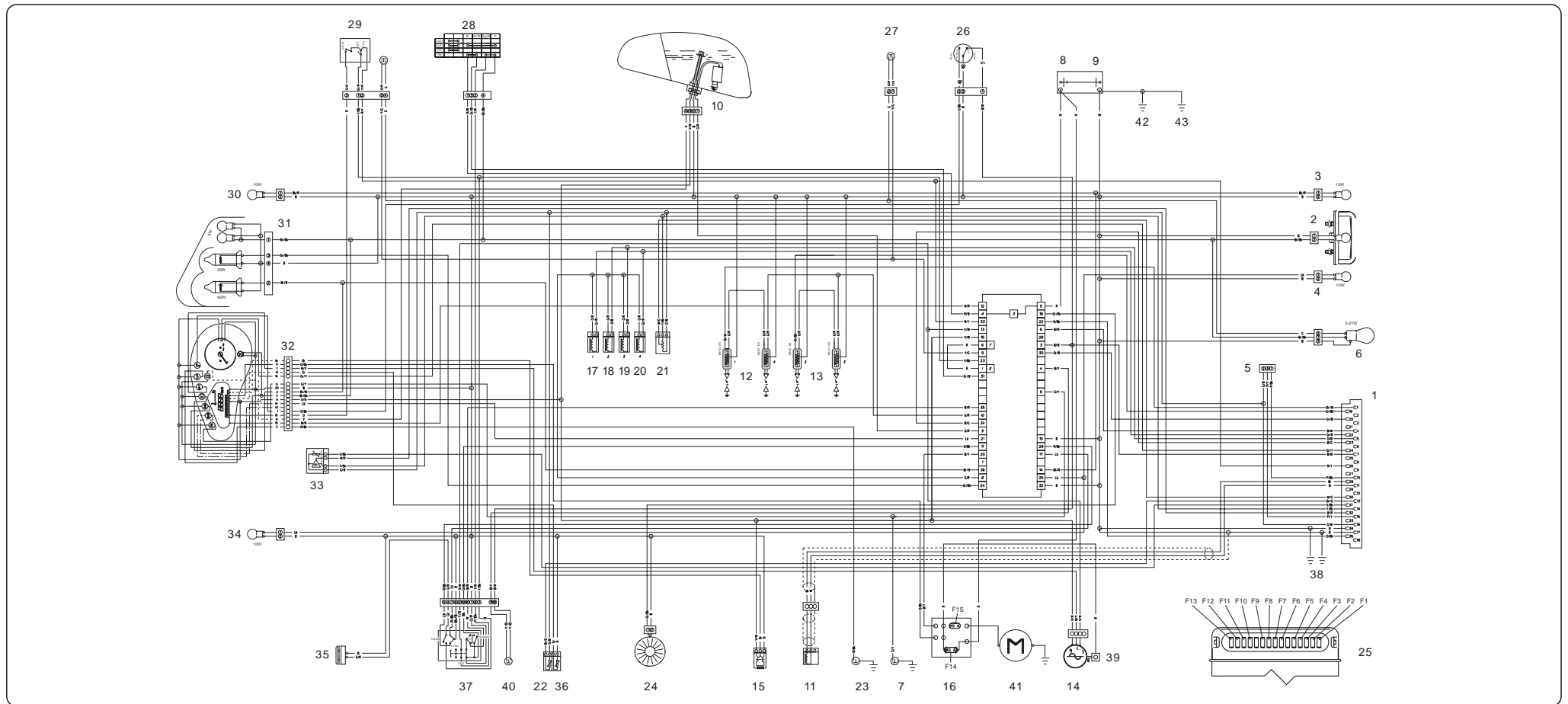

Parts list	
Ref.	Description
1	Power unit
2	Plate light
3	Turn indicator, right hand
4	Turn indicator, left hand
5	Diagnosis connector
6	Brake light
7	Neutral switch
8-9	Battery
10	Pump - Low fuel probe
11	Engine rpm sensor
12	Coil
13	Coil
14	Alternator
15	Speed sensor

Parts list	
Ref.	Description
16	Solenoid starter
17-18	Injectors
19-20	Injectors
21	Throttle potentiometer
22	Water temperature sensor for power unit
23	Oil switch
24	Heater fan
25	Fuses
26	Side stand switch
27	Rear brake switch
28	Key switch
29	Safety and front brake switch
30	Turn indicator, right hand
31	Front light

Parts list	
Ref.	Description
32	Display
33	Air pressure/temperature sensor
34	Turn indicator, left hand
35	Horn
36	Water temperature sensor for display thermometer
37	Light switch
38	Frame - power unit ground
39	Battery recharge
40	Clutch switch
41	Starter
42	Frame ground
43	Engine ground

Wires colors list	
Letter(s)	Color
R	Red
Y	Yellow
B	Blue
G	Green
W	White
Bk	Black
P	Pink
V	Violet
Sb	Sky blue
Gr	Grey
O	Orange
Br	Brown

In combined colors, background and marking colors have been pointed out. E.g. : Br/Bk.

Fuses list		
Ref.	Amperage (A)	Application
F1	5	Warning light
F2	5	Position light
F3	5	Speed sensor
F4	5	Turn indicator light, right hand
F5	5	Turn indicator light, left hand
F6	15	Heater fan
F7	5	Brake light
F8	15	"LATCH" relay
F9	7.5	Starter switch
F10	15	Low beam
F11	5	Dashboard clock
F12	15	High beam
F13	15	Injectors - Fuel pump - Coils
F14	40	Battery recharge
F15	40	Battery recharge supply



Phase 1
Initial battery charging
Perform the initial charge of the battery according to the instruction sheet enclosed in its package.

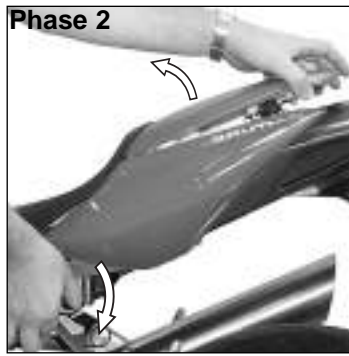

Phase 2
Assembling the battery
Insert the motorcycle key in the rear lock. Rotate the key clockwise while lifting the pillion.

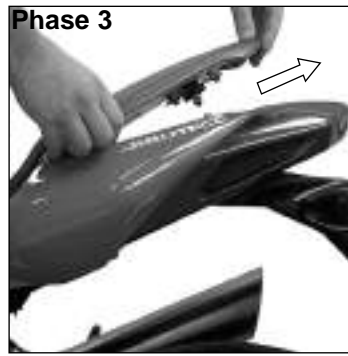

Phase 3
Remove the pillion as shown in the figure.

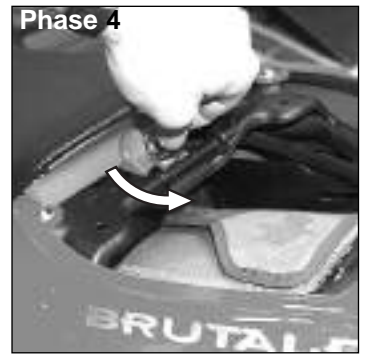

Phase 4
Rotate the driver's saddle catch as shown in the figure.

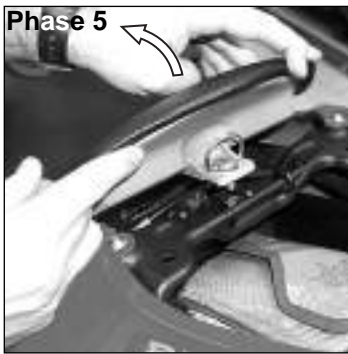

Phase 5
Lift the driver's saddle and remove it.



Phase 6
Insert the battery in its proper compartment.
⚠ WARNING
The initial battery charging must be performed before assembling the battery on the vehicle.



Phase 7
Assembling the battery terminals
Fit the 2 positive terminals (+) on the corresponding battery pole, respecting their disposition as shown in the figure. Pay attention to the colours of the cables in order to correctly place them.

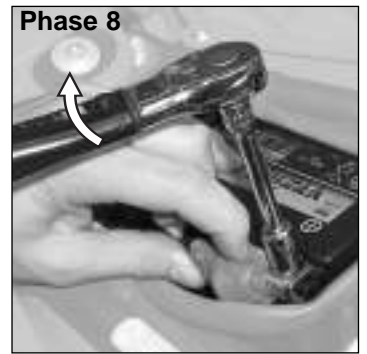

Phase 8
Rotate the positive terminals screw and tighten it at the prescribed torque by using a dynamometric key.
Tightening torque: 7 ÷ 8 Nm



Phase 9
Afterwards, fit the **protective cap** on the positive pole (see figure).



Phase 10
Fit the 2 negative terminals (-) on the corresponding battery pole, respecting their disposition as shown in the figure.

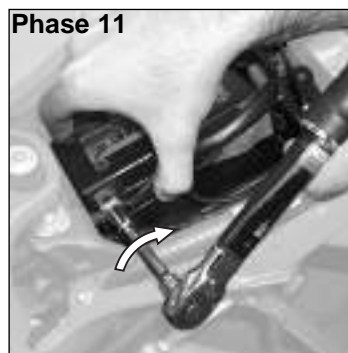

Phase 11
Rotate the negative terminals screw and tighten it at the prescribed torque by using a dynamometric key.
Tightening torque: 7 ÷ 8 Nm
⚠ CAUTION: Before tightening the screw, make sure that the cables are correctly placed (see figure on the reverse side of this sheet).



Phase 12
⚠ WARNING: When the assembly operations have been completed, make sure that the positive terminal cable is placed within the rear frame (see figure).
Replace the driver's saddle and the pillion by inversely performing the operations described in the phases from 2 to 5.

NEGATIVE CABLE (-)

NEGATIVE POLE (-)

NEGATIVE CABLE (-)

 **CAUTION:** Before tightening the screw, make sure that the cables are correctly placed (see figure).

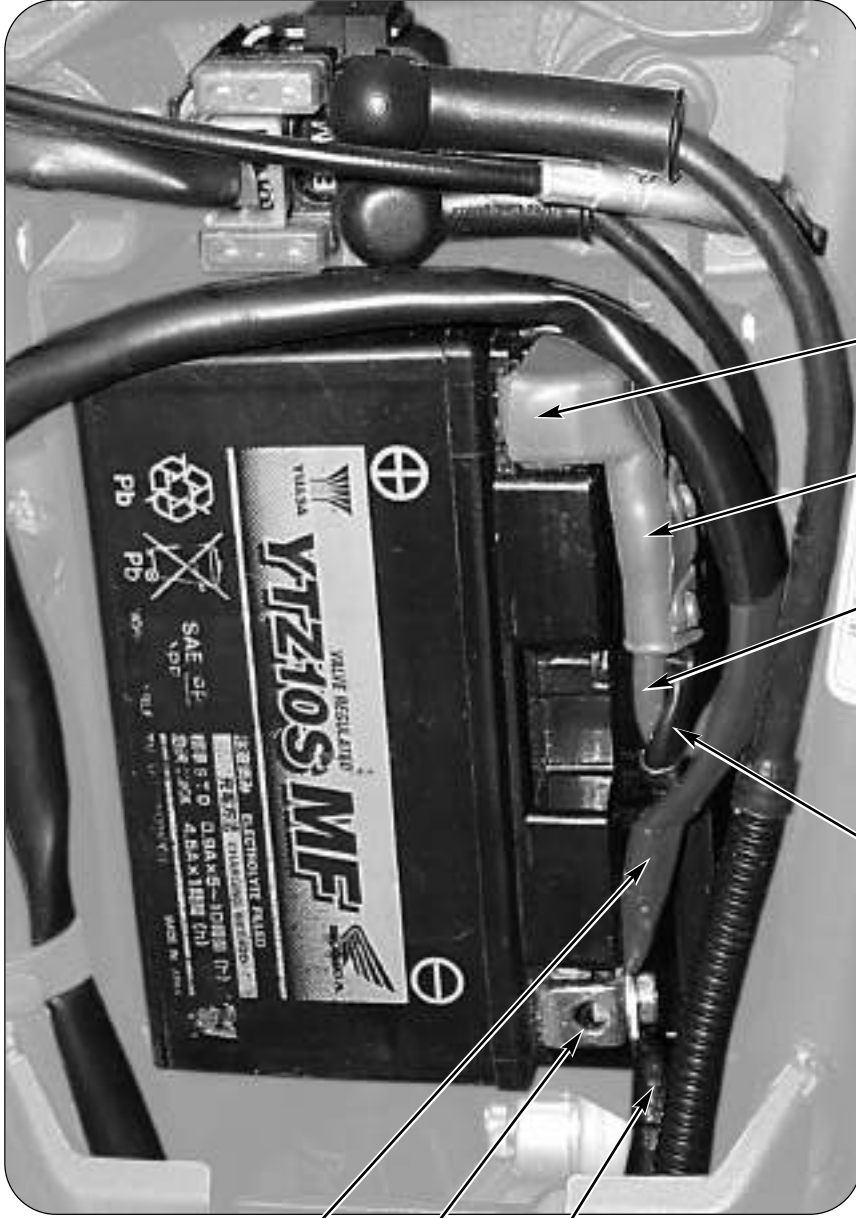

POSITIVE POLE (+)

PROTECTIVE CAP

POSITIVE CABLE (+)

POSITIVE CABLE (+)

 **WARNING:** When the assembly operations have been completed, make sure that the positive terminal cable is placed within the rear frame (see figure).

- Dispositivo idraulico di frenatura in compressione (Bassa velocità)
- Compression damping hydraulic device (Low speed)
- Dispositif hydraulique de freinage en compression (Vitesse basse)
- Hydraulische Kompressionsbremse (Niedrige Gänge)
- Dispositivo hidráulico de frenado en compresión (Baja velocidad)

- Dispositivo idraulico di frenatura in compressione (Alta velocità)
- Compression damping hydraulic device (High speed)
- Dispositif hydraulique de freinage en compression (Vitesse élevée)
- Hydraulische Kompressionsbremse (Hohe Gänge)
- Dispositivo hidráulico de frenado en compresión (alta velocidad)

- Dispositivo idraulico di frenatura in estensione
- Rebound damping hydraulic device
- Dispositif hydraulique de freinage en détente
- Hydraulische Ausdehnungsbremse
- Dispositivo hidráulico de frenado en extensión

- Dispositivo idraulico di frenatura in estensione
- Rebound damping hydraulic device
- Dispositif hydraulique de freinage en détente
- Hydraulische Ausdehnungsbremse
- Dispositivo hidráulico de frenado en extensión

- Dispositivo idraulico di frenatura in compressione
- Compression damping hydraulic device
- Dispositif hydraulique de freinage en compression
- Hydraulische Kompressionsbremse
- Dispositivo hidráulico de frenado en compresión

- Dispositivo idraulico di frenatura in compressione
- Compression damping hydraulic device
- Dispositif hydraulique de freinage en compression
- Hydraulische Kompressionsbremse
- Dispositivo hidráulico de frenado en compresión

- Dispositivo idraulico di frenatura in estensione
- Rebound damping hydraulic device
- Dispositif hydraulique de freinage en détente
- Hydraulische Ausdehnungsbremse
- Dispositivo hidráulico de frenado en extensión

BRUTALE			
Brutale 750 S			
Tipo di assetto - Type of geometry - Type d'assiette - Einstellungsart - Tipo de equilibrado			
	Soffice <i>Soft</i> <i>Souple</i> <i>Weich</i> <i>Suave</i>	Standard	Rigido <i>Stiff</i> <i>Rigide</i> <i>Hart</i> <i>Duro</i>
Sospensione anteriore <i>Front suspension</i> <i>Suspension avant</i> <i>Vordere Federung</i> <i>Suspensión delantera</i>			
Precarico molla <i>Spring preload</i> <i>Précharge du ressort</i> <i>Federvorspannung</i> <i>Precarga muelle</i>	1 giri turns tours Drehzahl revoluciones	2 giri turns tours Drehzahl revoluciones	3 giri turns tours Drehzahl revoluciones
Freno in estensione <i>Rebound damping</i> <i>Frein en détente</i> <i>Ausdehnungsbremse</i> <i>Freno en extensión</i>	12 scatti clicks emboîtements Rasten disparos	10 scatti clicks emboîtements Rasten disparos	7 scatti clicks emboîtements Rasten disparos
Freno in compressione <i>Compression damping</i> <i>Frein en compression</i> <i>Kompressionsbremse</i> <i>Freno en compresión</i>	12 scatti clicks emboîtements Rasten disparos	10 scatti clicks emboîtements Rasten disparos	7 scatti clicks emboîtements Rasten disparos
Sospensione posteriore <i>Rear suspension</i> <i>Suspension arrière</i> <i>Hintere Federung</i> <i>Suspensión trasera</i>			
Frenatura in estensione <i>Rebound damping</i> <i>Freinage en détente</i> <i>Ausdehnungsbremse</i> <i>Frenado en extensión</i>	12 scatti clicks emboîtements Rasten disparos	8 scatti clicks emboîtements Rasten disparos	7 scatti clicks emboîtements Rasten disparos
Frenatura in compressione <i>Compression damping</i> <i>Freinage en compression</i> <i>Kompressionsbremse</i> <i>Frenado en compresión</i>	0 scatti clicks emboîtements Rasten disparos	6 scatti clicks emboîtements Rasten disparos	12 scatti clicks emboîtements Rasten disparos
Frenatura in compressione <i>Compression damping</i> <i>Freinage en compression</i> <i>Kompressionsbremse</i> <i>Frenado en compresión</i>	15 scatti clicks emboîtements Rasten disparos	12 scatti clicks emboîtements Rasten disparos	8 scatti clicks emboîtements Rasten disparos
Frenatura in estensione <i>Rebound damping</i> <i>Freinage en détente</i> <i>Ausdehnungsbremse</i> <i>Frenado en extensión</i>	8 scatti clicks emboîtements Rasten disparos	8 scatti clicks emboîtements Rasten disparos	8 scatti clicks emboîtements Rasten disparos
Frenatura in compressione <i>Compression damping</i> <i>Freinage en compression</i> <i>Kompressionsbremse</i> <i>Frenado en compresión</i>	18 scatti clicks emboîtements Rasten disparos	18 scatti clicks emboîtements Rasten disparos	18 scatti clicks emboîtements Rasten disparos
Frenatura in compressione <i>Compression damping</i> <i>Freinage en compression</i> <i>Kompressionsbremse</i> <i>Frenado en compresión</i>	12 scatti clicks emboîtements Rasten disparos	12 scatti clicks emboîtements Rasten disparos	12 scatti clicks emboîtements Rasten disparos

(*) : Per l'utilizzo del veicolo con passeggero si consiglia di aumentare il precarico molla dell'ammortizzatore posteriore di 2 giri. Questa operazione deve essere tassativamente eseguita da un concessionario MV Agusta. - *To use the vehicle with passenger, we suggest to increase the rear suspension spring preload of 2 turns. This operation must be performed only by a MV Agusta authorized dealer.* - Pour utiliser le véhicule avec le passager, nous suggérons d'augmenter la précharge de ressort de la suspension arrière de 2 tours. Cette intervention doit être impérativement effectuée par un concessionnaire officiel MV Agusta. - *Für das Verwenden des Trägers mit dem Beifahrer, schlagen wir vor, um die hintere Federungsfedervorspannung von 2 Umdrehungen zu erhöhen. Änderungen an der Trimmlage dürfen ausschließlich von MV Agusta Vertragshändlern vorgenommen werden.* - Para usar el vehículo con el pasajero, sugerimos el aumento de la precarga del resorte de la suspensión posterior de 2 vueltas. Dicha intervención debe ser realizada por un concesionario oficial MV Agusta.



MV AGUSTA S.p.A. - Technical Assistance Service
Via Nino Bixio, 8 - 21024 Cassinetta di Biandronno (VA)
ITALY - Tel. ++ 39 0332 254.111 Fax ++ 39 0332 756.509
www.mvagusta.it Part No. 8A00A4902 Edition No.1

