







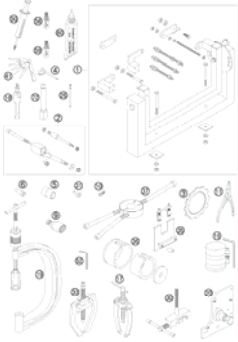
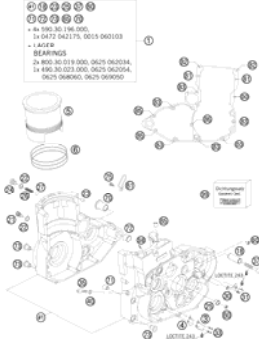

HUSABERG FE 450-E 2008

SPARE PARTS MANUAL: ENGINE

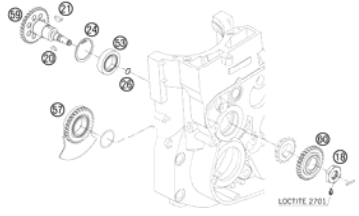
ART.NO.: 3CM090021HEN

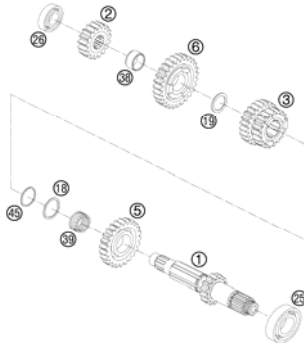
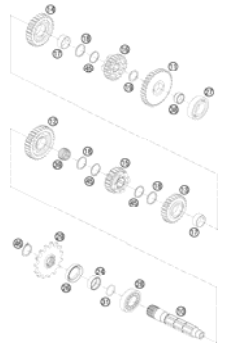
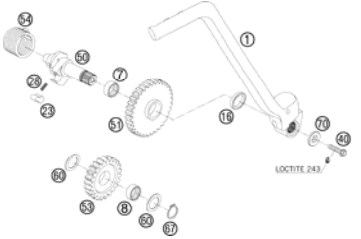
ENGLISH

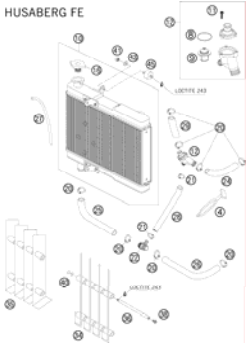

SPECIAL TOOLS  3	ENGINE CASE  4	CLUTCH COVER  5	BALANCER SHAFT  6
CRANKSHAFT, PISTON  7	CARBURETOR  8	CLUTCH  11	TRANSMISSION I - MAIN SHAFT  12
TRANSMISSION II - COUNTERSHAFT  13	KICKSTARTER  14	SHIFTING MECHANISM  15	COOLING SYSTEM  16

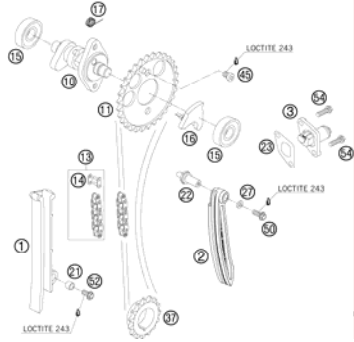
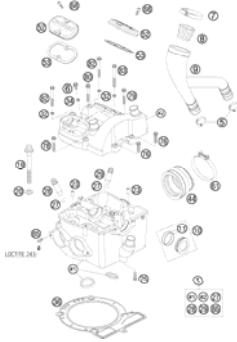
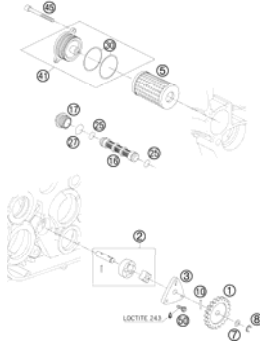
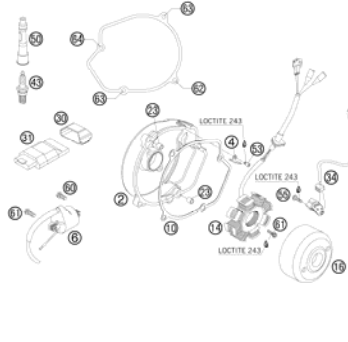
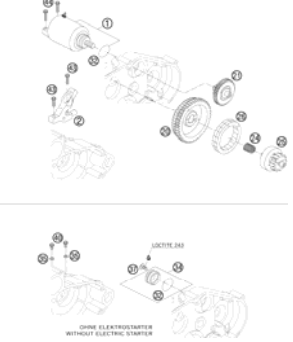
<p>VALVE DRIVE</p>  <p style="text-align: right;">17</p>	<p>TIMING VALVE</p>  <p style="text-align: right;">18</p>	<p>CYLINDER HEAD</p>  <p style="text-align: right;">19</p>	<p>LUBRICATING SYSTEM</p>  <p style="text-align: right;">20</p>
<p>IGNITION SYSTEM</p>  <p style="text-align: right;">21</p>			
<div style="display: flex; align-items: center;"> <div style="background-color: #cccccc; padding: 20px; margin-right: 20px; text-align: center;"> ! </div> <div> <p>All information contained is without obligation. KTM-Sportmotorcycle AG particularly reserves the right to modify any equipment, technical specifications, prices, colors, shapes, materials, services, service work, constructions, equipment and the like so as to adapt them to local conditions or to cancel any of the above items, all without previous announcement and without giving reasons. KTM may stop manufacturing certain models without previous notice. KTM shall not be held liable for any deviations of availability and/or ability to deliver, illustrations, descriptions, printing and/or other errors. The illustrated models partly contain extra equipment, which is not applied to standard models. © by KTM-SPORTMOTORCYCLE AG, Mattighofen AUSTRIA; All rights reserved; Reprint, also in extracts, with written allowance of KTM-SPORTMOTORCYCLE AG, Mattighofen only.</p> </div> </div>			

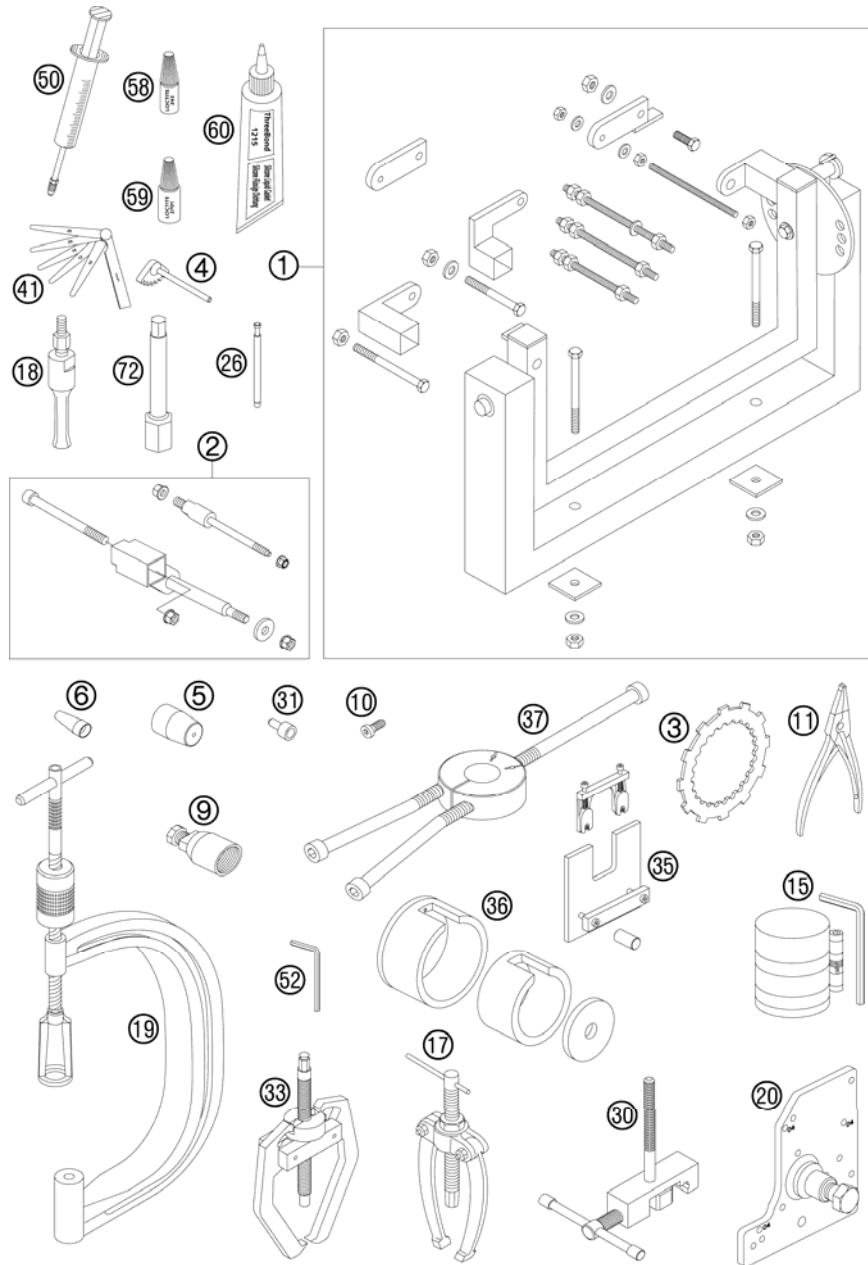

FIG	PART NUMBER	DESCRIPTION	QTY
1	56012001000	UNIVERSAL MOUNTING RACK '96	1
2	80029002100	ENGINDE HOLDER HUSABERG 04	1
3	80029003000	CLUTCH HOLDER 04	1
4	80029004000	GEAR SEGMENT CPL. 04	1
5	80029005000	MOUNT.SLEEVE F. LEFT SSR C.S.	1
5	80029105000	MOUNT.SLEEVE F. RIGHT SSR C.S.	1
5	80029205000	MOUNT.SLEEVE F. SSR KICKST.-S.	1
6	59029005010	MOUNTING SLEEVE SEAL RING	1
9	58012009000	FLYWHEEL EXTRACTOR	1
10	58030080000	LOCATING SCREW M8 L=23	1
11	51012011000	SPECIAL CIRCLIP PLIER	1
15	60029015000	PISTON RING COMPRESSOR CPL. 03	1
17	15112017000	BUSHING EXTRACTOR	1
18	15112018000	INTERN.BEAR.PULLER 12-16 MM	1
19	59029019000	VALVE SPRING LEVER	1
20	80029020000	HOUSING SEPARATING TOOL 04	1
26	59029026006	LIMIT PLUG GAUGE F.VALVE GUIDE	1
30	80029030000	RIVETTING TOOL TIMING CHAIN	1
31	80029031000	PROTECTION COVER F. CRANKSHAFT	1
33	59029033000	EXTRACTOR FOR TIMING GEAR	1
35	80029035000	PRESS OUT TOOL CONROD BEARING	1
36	80029036000	PRESS IN TOOL CONROD BEARING	1
37	58429037037	MOUNTING TOOL INNER RING NJ206	1
41	59029041000	FEEL. GAUGE SET 10,12,15,20,25	1
50	50329050000	VENT INJEKTION HYDR. CLUTCH	1
52	80029052000	SAFETY-TORX TX20	1
58	6899785	LOCTITE 243 BLUE 6CCM	1
59	80029059000	LOCTITE 2701 GREEN 5ML	1
60	309098	SILICON GASKET THREE-BOND	1
72	77029072000	SPARK PLUG KEY 250 SX-F	1

088002910 / C088002910

* NEW PART

X AS REQUIRED

#1 18 23 25 37 60

71 72 73 65 70

+ 4x 590.30.196.000,
1x 0472 042175, 0015 060103

+ LAGER
BEARINGS

2x 800.30.019.000, 0625 062034,
1x 490.30.023.000, 0625 062054,
0625 068060, 0625 069050

①

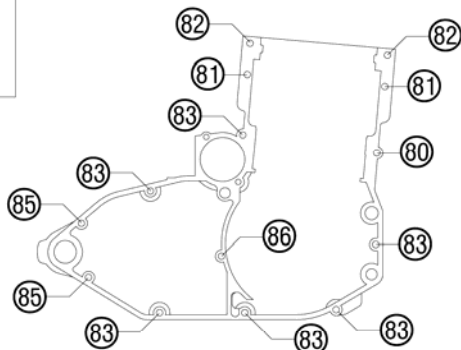

99

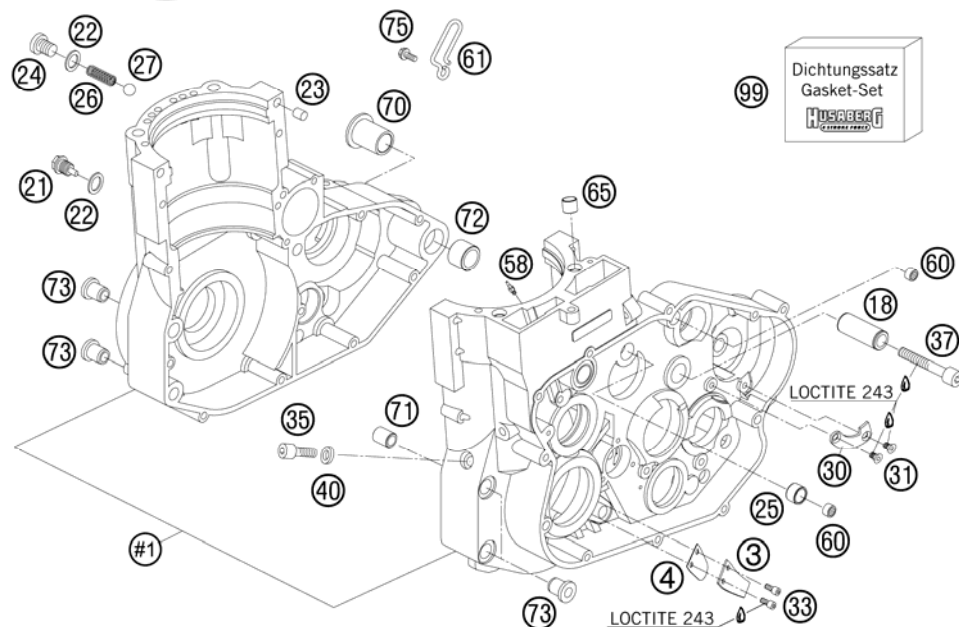

FIG	PART NUMBER	DESCRIPTION	QTY
1	81030000144	ENGINE CASE CPL. 450	05
3	80030003050	STOP SHEET MEMBRANE	03
4	80030003051	MEMBRANE	03
5	81030005000	CYLINDER LINER 100MM 450	03
6	0770102020	O-RING 102,00X2,00 VITON	02
18	59033018000	BUSHING PIN	2000
21	58030021000	OILDRAIN PLUG W.MAG. M 12X1,5	1
22	58038022000	CU-SEAL RING DIN7603-12X18X1,5	2
23	59030023000	DOWEL 6X8X11,5	3
24	0908120153	PLUG DIN0908-M12X1,5	1
25	80040025050	BUSHING 12X15X9,7	1
26	80038026000	SPRING OIL PRES.RELIEF HUSA.04	1
27	0401100000	BALL D=10 DIN 5401	1
30	80033060000	ENGAGEMENT SLEDGE	03
31	0019050103	INT. TORX FLAT HEAD M 5X10 8.8	2
33	0912040063	AH SCREW DIN0912-M 4X 6	2
35	0912080163	AH SCREW DIN0912-M 8X16	1
37	0912060404	AH SCREW DIN0912-M 6X40 A2	1
40	58030081000	CU-SEAL RING 8 X 14 X 3	1
58	80030058060	OIL JET "60" M4	1
60	80040060000	NEEDLE BEARING HK 0810	03
61	80031081000	BOW FOR BREATHER HOSE	04
65	80036085000	DOWEL 10,5X12X10	03
70	80030170000	DOWEL ENGINE CASE REAR	03
71	80030071000	DOWL 9X13X15,5	03
72	80030072000	DOWEL 16,1X22X16	03
73	80030171000	DOWEL ENGINE CASE FRONT	03
75	0015050123	HH COLLAR SCREW M 5X12 WS=8	1
80	0015060353	HH COLLAR SCREW M 6X35 WS=8	1
81	0015060403	HH COLLAR SCREW M 6X40 WS=8	2
82	0015060453	HH COLLAR SCREW M 6X45 WS=8	2
83	0015060503	HH COLLAR SCREW M 6X50 WS=8	6
85	0015060603	HH COLLAR SCREW M 6X60 WS=8	2
86	0015060653	HH COLLAR SCREW M 6X65 WS=8	1
99	80030099000	GASKET SET 450-650 HUSABERG 04	1

088003010 / C088003010

* NEW PART

X AS REQUIRED

CLUTCH COVER

HUSABERG FE 450-E 2008

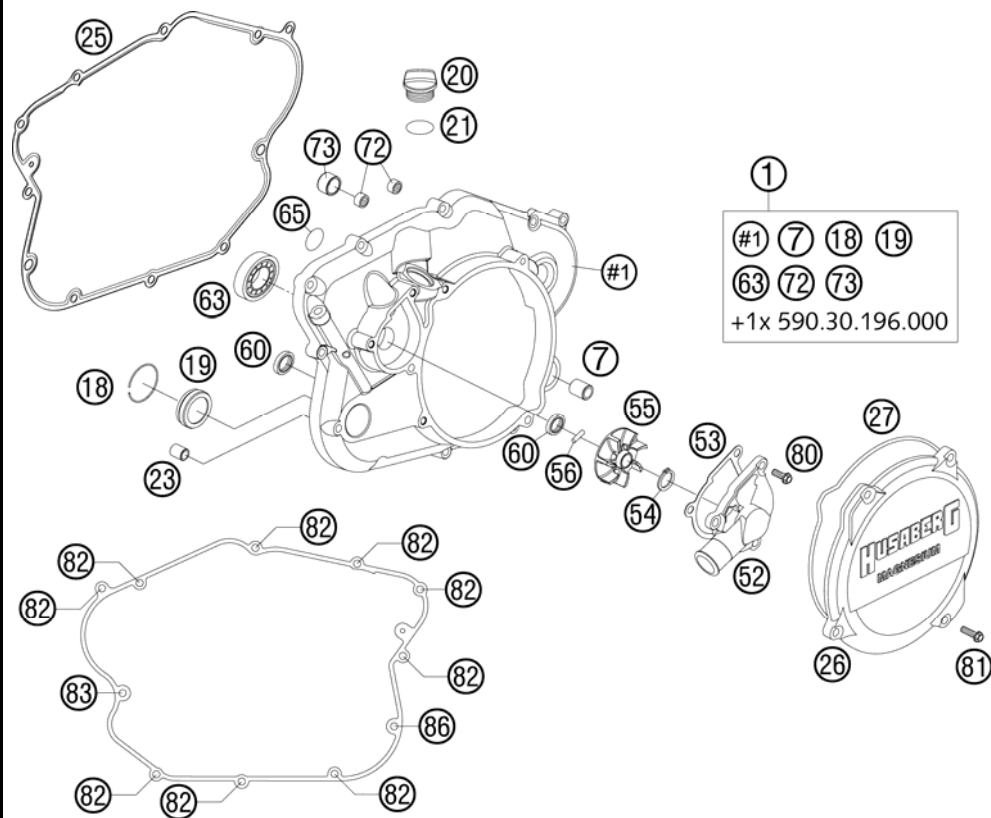

FIG	PART NUMBER	DESCRIPTION	QTY
1	80030001044	CLUTCH COVER CPL. 04	1
7	80034007053	SLIDING SLEEVE PLASTIC-COAT 03	1
18	61030019050	CIRCLIP OIL LEVEL GLASS 03	1
19	59030019000	OIL LEVEL GLASS G 1777 Y	1
20*	80030020000	OIL PLUG	1
21*	0770191015	O-RING 19,00X3,00 NBR	1
23	59030023000	DOWEL 6X8X11,5	2
25	80030025000	GASKET CLUTCH COVER 03	1
26	80030026000	OUTER CLUTCH COVER 03	1
27	80030027100	GASKET OUTER CLUTCH COVER 05	1
52	80035052000	WATER PUMP COVER 03	1
53	80035053000	GASKET WATER PUMP COVER 03	1
54	0471100010	CIRCLIP DIN0471-10X1	1
55	80035055000	WATER PUMP GEAR 03	1
56	0402251980	NEEDLEROL.DIN5402 NRA 2,5X19,8	1
60	0760101844	SHAFT SEAL RING 10X18X4 BSL V.	2
63	0625062013	BALL BEARING SPEC.B.B.SKF 6201	1
65	0770173024	O-RING 17,30X2,40 NBR 70 SH	1
72	80040060000	NEEDLE BEARING HK 0810 03	2
73	80040025050	BUSHING 12X15X9,7	1
80	0015060163	HH COLLAR SCREW M 6X16 WS=8	3
81	0015060203	HH COLLAR SCREW M 6X20 WS=8	4
82	0015060253	HH COLLAR SCREW M 6X25 WS=8	9
83	0015060303	HH COLLAR SCREW M 6X30 SW=8	1
86	0015060453	HH COLLAR SCREW M 6X45 WS=8	1

088003020 / C088003020

* NEW PART

X AS REQUIRED

BALANCER SHAFT

HUSABERG FE 450-E 2008

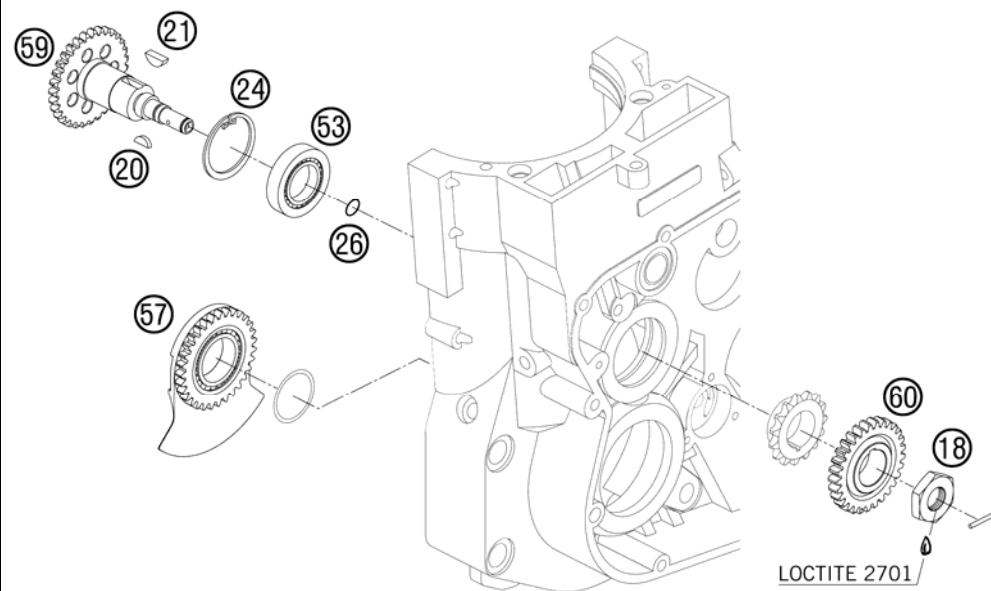

FIG	PART NUMBER	DESCRIPTION	QTY
18	80030018020	NUT M16X1 WS=30 03	1
20	0888030050	WOODRUFF KEY DIN6888-3X5X13	1
21	6946005	WOODRUFF KEY 5X6,5 HARDED	1
24	0472042175	CIRCLIP DIN0472-42X1,75	1
26	0770010012	O-RING 10, 00X1, 20 NBR	1
53	0625069050	BALL BEARING 6905 J1LLUC3	1
57	80030057100	BALANCER SHAFT CPL. 450-650 06	1
59	80030059000	MAIN SHAFT BALANCER SHAFT 03	1
60	80030059050	GEAR WHEEL B.SH.-SHAFT 29-T 03	1

088003030 / C088003030

* NEW PART

X AS REQUIRED

CRANKSHAFT, PISTON

HUSABERG FE 450-E 2008

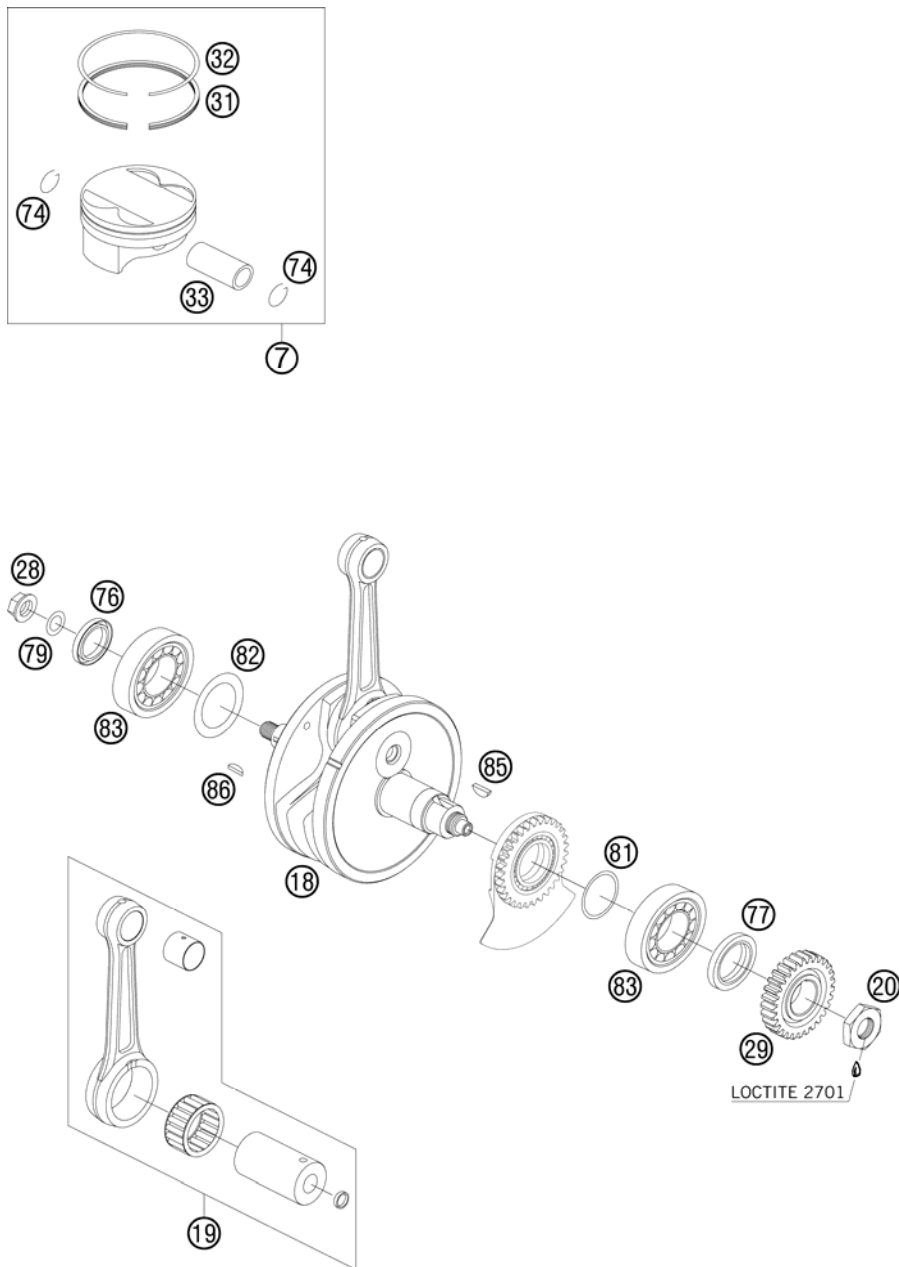

FIG	PART NUMBER	DESCRIPTION	QTY
7	81030007000 I	PISTON I CPL. 100 MM 450 03	1
7	81030007000 II	PISTON II CPL. 100 MM 450 03	1
18	81030018100	CRANKSHAFT 450 FE CPL. 05	1
19	81030015100	CONROD REP. KIT 450 05	1
20	80030018020	NUT M16X1 WS=30 03	1
28	51030028100	COLLAR NUT M12X1 LEFT WS=17	1
29	80032000029	PRIMARY GEAR 29-T 03	1
31	60030032000	OIL SCRAPER RING D=100MM 03	1
32	80030032000	RECTANGULAR RING 100X1,25	1
33	59030033000	PISTON PIN BOLT 20X15,8/12X50	1
74	59030074000	CIRCLIP C20X1,5	2
76	0760254071	SHAF.SEAL RING 25X40X7 BAUM3SL	1
77	0760305271	SHAFT SEAL RING 30X52X7	1
79	0137120000	SPRING WASHER DIN0137-B12	1
81	80030081010	THRUST WASHER 31X36X0,10	x
81	80030081020	THRUST WASHER 31X36X0,20	x
81	80030081030	THRUST WASHER 31X36X0,30	x
82	56030081000	THRUST WASHER 30,5X45X0,10	x
82	56030081100	THRUST WASHER 30,7X47X0,15	x
82	56030081200	THRUST WASHER 30,5X45X0,30	x
83	80030019000	CYL.ROLLBEAR.NJ206ECP/C3HVC058	2
85	6946005	WOODRUFF KEY 5X6,5 HARDED	1
86	0888030050	WOODRUFF KEY DIN6888-3X5X13	1

088003060 / C088003060

* NEW PART

X AS REQUIRED

CARBURETOR

HUSABERG FE 450-E 2008

ACHTUNG !!! Vor dem Einbau des Vergasers, Bedüsung kontrollieren. **CAUTION !!!** Before mounting the carburetor, check the jetting.

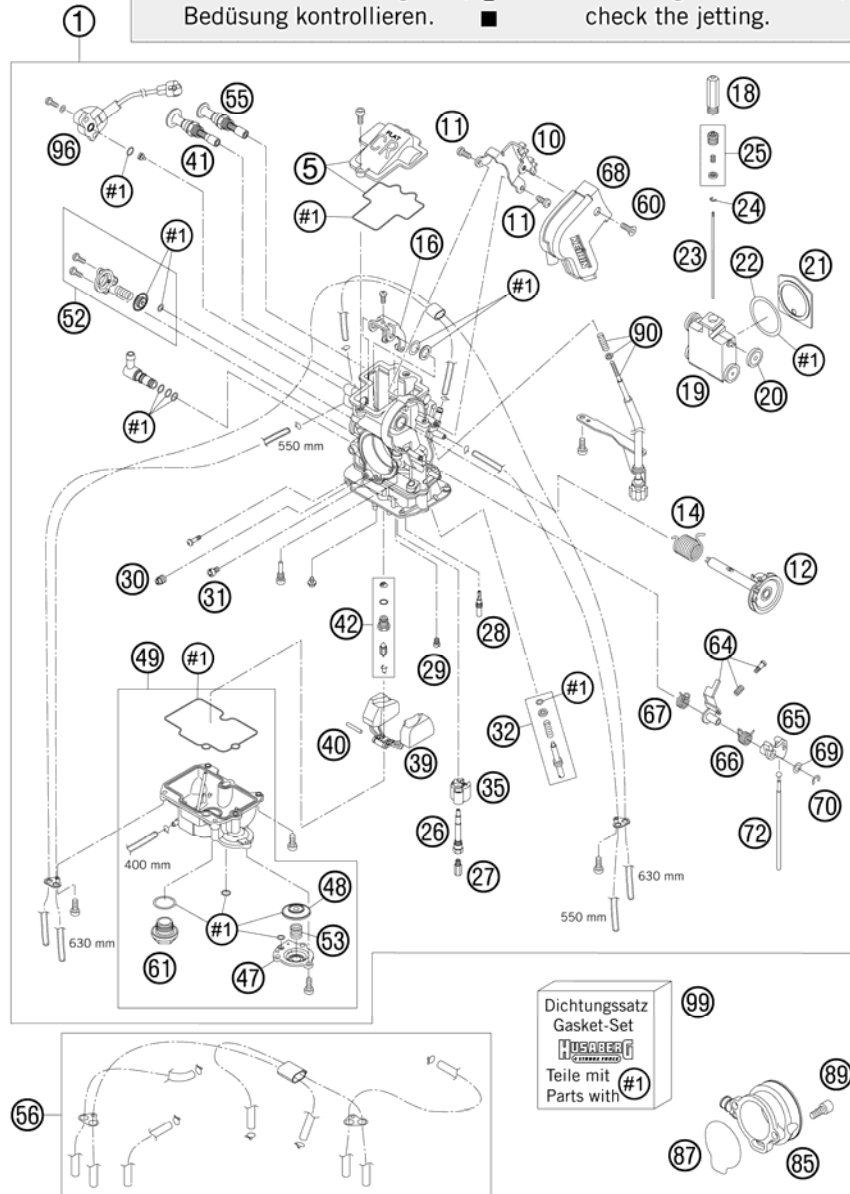

FIG	PART NUMBER	DESCRIPTION	QTY
1	80031001300	CARBURETOR KEIHIN FCR-MX39 05	1
5	57331027044	CARBURETOR COVER WITH GASKET	1
10	57331080000	BRACKET PLATE FOR THR. CABLE	1
11	57331055000	SCREW M 5 X 8	2
12	57331046000	THROTTLE SHAFT CPL.	1
14	57331046050	COIL SPRING THROTTLE SHAFT	1
16	57331035051	LINK ARM THROTTLE VALVE CPL.	1
18	59031029006	SLIDE STOP L=44MM 04 450-650 FE+FS (EU+AUS)	1
19	57331035000	THROTTLE VALVE CPL.	1
20	59031035050	BUSHING THROTTLE VALVE	4
21	57331035153	GASKET PLATE THROTTLE VALVE 04	1
22	59031035052	GASKET WASHER THROTTLE VALVE	1
23	59031022000	JET NEEDLE KEIHIN OBDVR	x
23	59031023200	JET NEEDLE KEIHIN OBDVT	1
24	59031029000	BAR CLIP	1
25	57331032000	NEEDLE SET SCREW CPL.	1
26	59031121000	NEEDLE JET FCR-MX	1
27	54531623160	MAIN JET 160 KEIHIN	x
27	54531623162	MAIN JET 162 KEIHIN	x
27	54531623165	MAIN JET 165 KEIHIN	x
27	54531623168	MAIN JET 168 KEIHIN	x
27	54531623170	MAIN JET 170 KEIHIN	x
27	54531623172	MAIN JET 172 KEIHIN	x
27	54531623175	MAIN JET 175 KEIHIN	x
27	54531623178	MAIN JET 178 KEIHIN	x
27	54531623180	MAIN JET 180 KEIHIN	x
27	54531623182	MAIN JET 182 KEIHIN	x
27	54531623185	MAIN JET 185 KEIHIN	x
27	54531623188	MAIN JET 188 KEIHIN	x
27	54531623190	MAIN JET 190 KEIHIN	x
28	54531607038	IDLE JET 38 KEIHIN	x
28	54531607040	IDLE JET 40 KEIHIN	x
28	54531607042	IDLE JET 42 KEIHIN	x
28	54531607045	IDLE JET 45 KEIHIN	x
29	59031051085	STARTER JET 85	1

088003110 / C088003110

* NEW PART

X AS REQUIRED

CARBURETOR

HUSABERG FE 450-E 2008

ACHTUNG !!! Vor dem Einbau des Vergasers, Bedüsung kontrollieren. **CAUTION !!!** Before mounting the carburetor, check the jetting.

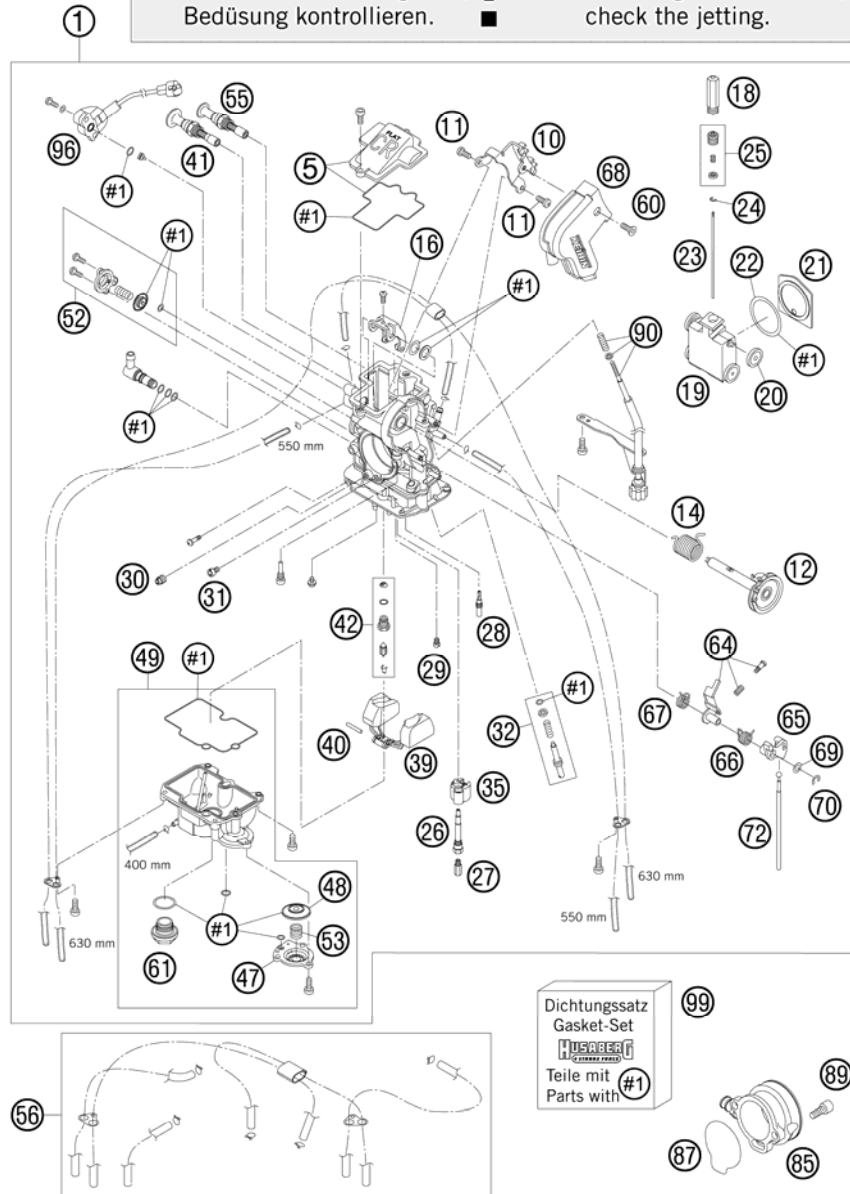

FIG	PART NUMBER	DESCRIPTION	QTY
30	57331007100	IDLE AIR JET 100 KEIHIN	1
31	57331037200	MAIN AIR JET 200 KEIHIN	1
32	59031017100	ADJUST SCREW CPL. FCR-MX	1
35	57331085000	BUFFER PLATE	1
39	57331009000	FLOAT CPL.	1
40	57331008000	ARM PIN FLOAT	1
41	57331075000	HOT-STARTER VALVE CPL.	1
42	57331020000	NEEDLE VALVE CPL.	1
47	57331060000	COVER ACCELERATOR PUMP	1
48	57331057100	DIAPHRAGM ACCELERATOR PUMP	1
49	80031011044	FLOAT CHAMBER CPL. SET	04
52	57331090000	AIR CUT VALVE 2002 ONLY FOR 650 FE+FS	1
53	59031059000	COIL SPRING	1
55	57331048000	STARTER VALVE CPL.	1
56	80031098000	BREATH.HOSE FCR-MX KEIHIN CPL.	1
60	0965050103	FLAT HEAD SCREW DIN0965-M 5X10	1
61	54531699000	PLUG M 18X1	1
64	57331062000	INTERMEDIATE LEVER CPL.	1
65	57331056000	LINK LEVER	1
66	57331059000	SPRING LINK LEVER	1
67	57331159000	SPRING INTERMEDIATE LEVER	1
68	57331038000	CARBURETOR COVER	1
69	57331087000	WASHER LINK LEVER	1
70	57331084000	E-CLIP	1
72	57331061000	ROD ACCELERATOR PUMP	1
85	59031040200	INTAKE FUNNEL FCR/FCR-MX 02 SIDEWARDS CLOSED	1
87	59031040010	O-RING FOR INTAKE FUNNEL	1
89	0912050123	AH SCREW DIN0912-M 5X12	2
90	80031025000	STOP SCREW CPL. FCR-MX	04
96	57331077000	TPS-SENSOR FCRMX 140MM	2002
99	57331099000	GASKET SET FCR-MX KEIHIN	1

088003110 / C088003110

* NEW PART

X AS REQUIRED

CLUTCH

HUSABERG FE 450-E 2008

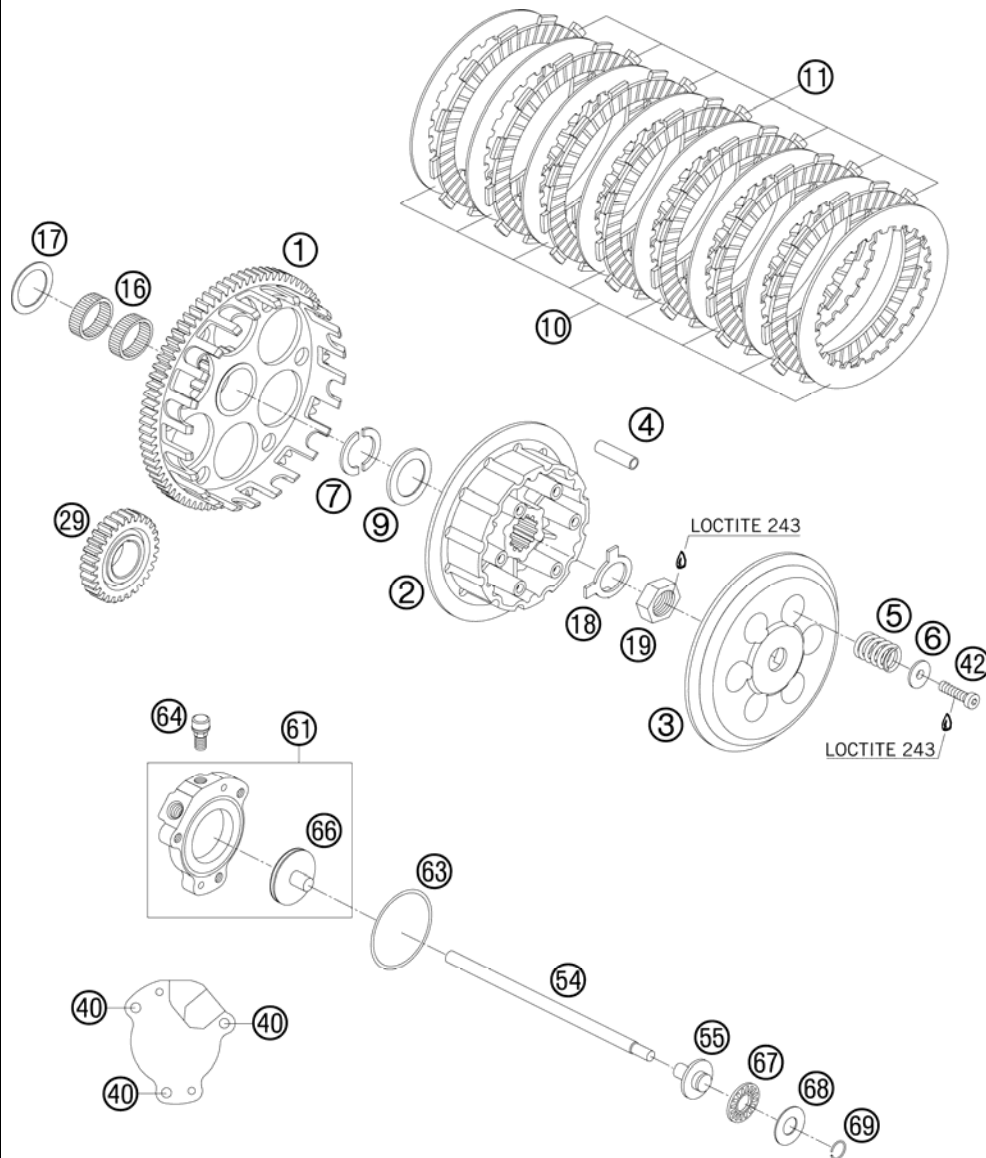

FIG	PART NUMBER	DESCRIPTION	QTY
1	80032000078	OUTER CLUTCH HUB 03	1
2	59032002500	INNER HUB - RACING 2007	1
3	59032003500	PRESSURE CAP WITH OIL BORE 07	1
4	59032004000	DRIVING SLEEVE D=8,L=31 2002	12
5	59032005000	CLUTCH SPRING 2,5X43MM	6
6	59032006050	SPRING RETAINER 6,2X12X18X5,2	6
7	59032007000	HALF-WASHER 03	2
9	59032009000	STEPPED WASHER 03	1
10	59032010100	INTERMEDIATE DISC 1MM 2002	8
11	59032011100	LINING DISC 2MM 04	7
16	0405252910	NEEDLE BEAR K 25X29X10	2
17	59032017000	SUPPORTWASHER 25X35X1	1
18	56532018000	LOCK WASHER	1
19	0936181505	HEXAGON NUT DIN0936-M18X1,5 R.	1
29	80032000029	PRIMARY GEAR 29-T 03	1
40	0912050163	AH SCREW DIN0912-M 5X16	3
42	0984060252	AH SCREW DIN6912 M6X25	6
54	80032054000	PUSH ROD 03	1
55	50332054051	PRESSURE PIECE 125-380 '98	1
61	80032061044	OUTPUT CYLINDER CPL. 2004	1
63	0770045015	O-RING 45,00X1,50 NBR 70	1
64	54732064000	BLEEDER SCREW WITH CAP	1
66	80032066000	PISTON + O-RING 2004	1
67	54637097200	AXIAL NEEDLE BEARING AXK 1226	1
68	54637098200	AXIAL WASHER AS1226 12X26X1	1
69	0993012000	CIRCLIP DIN7993-RW12	1

088003210 / C088003210

* NEW PART

X AS REQUIRED

TRANSMISSION I - MAIN SHAFT

HUSABERG FE 450-E 2008

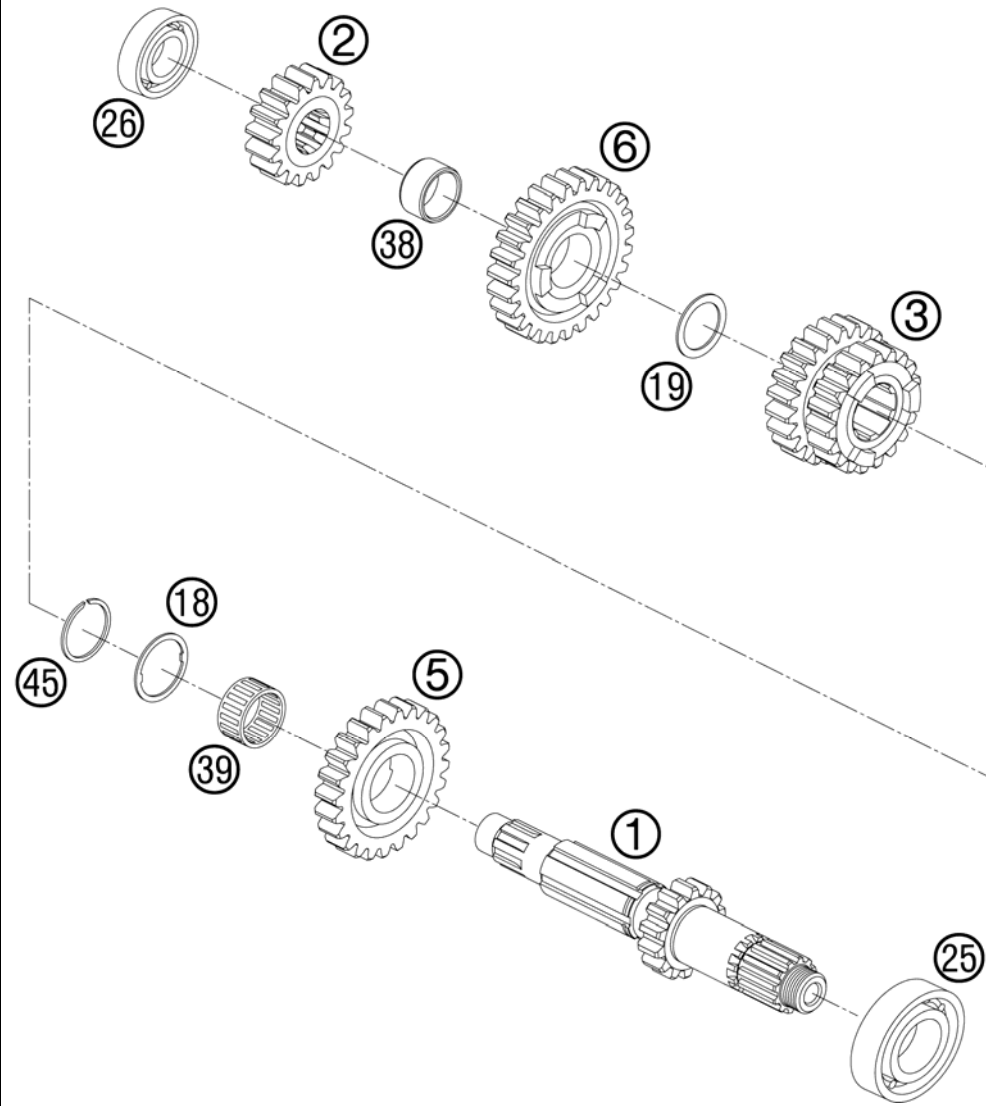

FIG	PART NUMBER	DESCRIPTION	QTY
1	80033001000	MAIN SHAFT 04	1
2	80033002017	SOLID GEAR 2ND G 17-T	1
3	80033003019	SLIDING GEAR 3RD/4TH G 19/23-T	1
5	80033005024	IDLER GEAR 5TH G 24-T	1
6	80033006027	IDLER GEAR 6TH G 27-T	1
18	80033018000	STOP DISC 25X30X1	1
19	80033019000	STOP DISC 21X28X1	1
25	0625062054	BALL BEARING 6205 C3 NTN	1
26	0625062034	BALL BEARING 6203 JR C3	1
38	0405202413	NEEDLE BEAR. K20X24X13	1
39	0405222613	NEEDLE BEAR. K 22X26X13 TN	1
45	80033022000	CIRCLIP SPA25-SD1,2	1

088003330 / C088003330

* NEW PART

X AS REQUIRED

TRANSMISSION II - COUNTERSHAFT

HUSABERG FE 450-E 2008

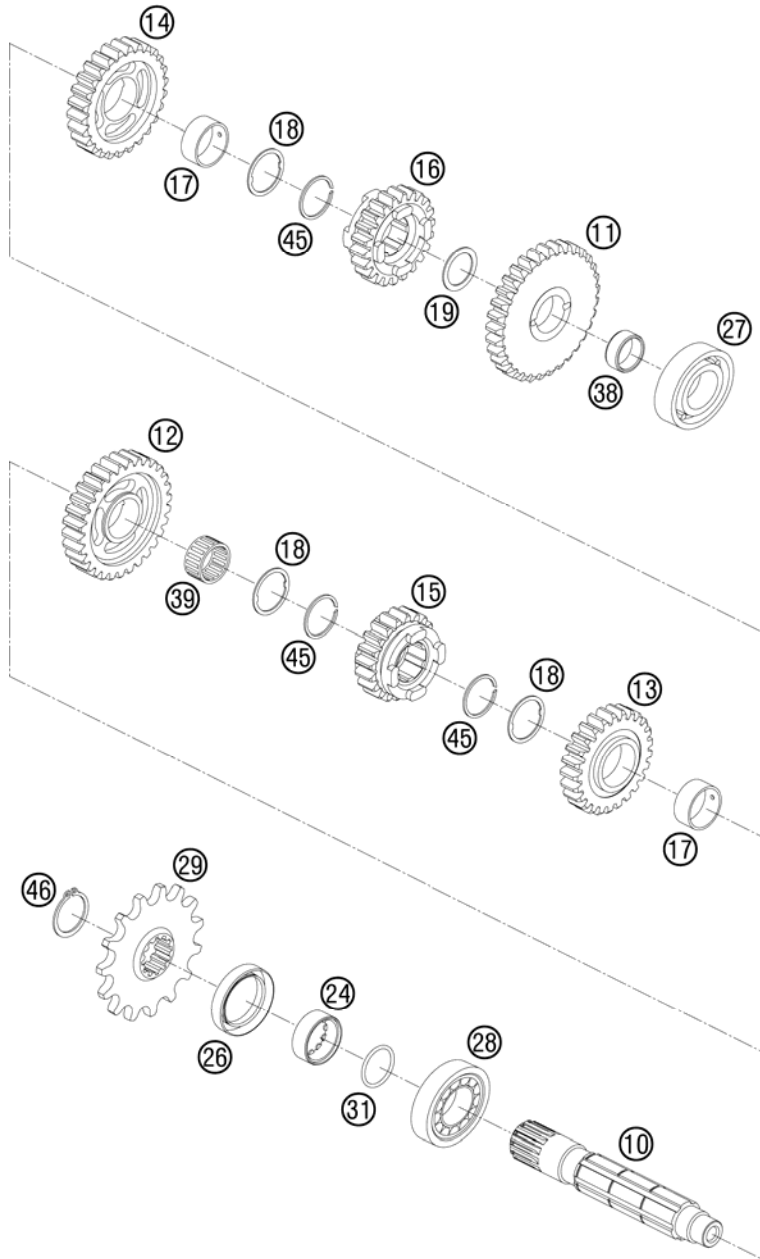

FIG	PART NUMBER	DESCRIPTION	QTY
10	80033010000	COUNTERSHAFT 04	1
11	80033011033	IDLER GEAR 1ST G 33-T	1
12	80033012030	IDLER GEAR 2ND G 30-T	1
13	80033014025	IDLER GEAR 4TH G 25-T	1
14	80033013026	IDLER GEAR 3RD G 26-T	1
15	80033016020	SLIDING GEAR 6TH G 20-T	1
16	80033015022	SLIDING GEAR 5TH G 22-T	1
17	80033007000	BUSHING 25X28X12	2
18	80033018000	STOP DISC 25X30X1	3
19	80033019000	STOP DISC 21X28X1	1
24	80033014000	SPACER BUSHING 11MM 03	1
26	0760304270	SH.SEAL RING 30X42X7 BAU2SLX2	1
27	0625062034	BALL BEARING 6203 JR C3	1
28	49030023000	CYL.ROLL BEARING NJ205	1
29	80033029013	SPROCKET 13-T 03	1
29	80033029014	SPROCKET 14-T 03	1
29	80033029015	SPROCKET 15-T 03	1
29	80033029016	SPROCKET 16-T 03	1
31	0770022016	O-RING 22,10X1,60 NBR 70 SH	1
38	50033098000	NEEDLE BEARING K20X24X10	1
39	0405222613	NEEDLE BEAR. K 22X26X13 TN	1
45	80033022000	CIRCLIP SPA25-SD1,2	3
46	0471250120	CIRCLIP DIN0471-25X1,2	1

088003360 / C088003360

* NEW PART

X AS REQUIRED

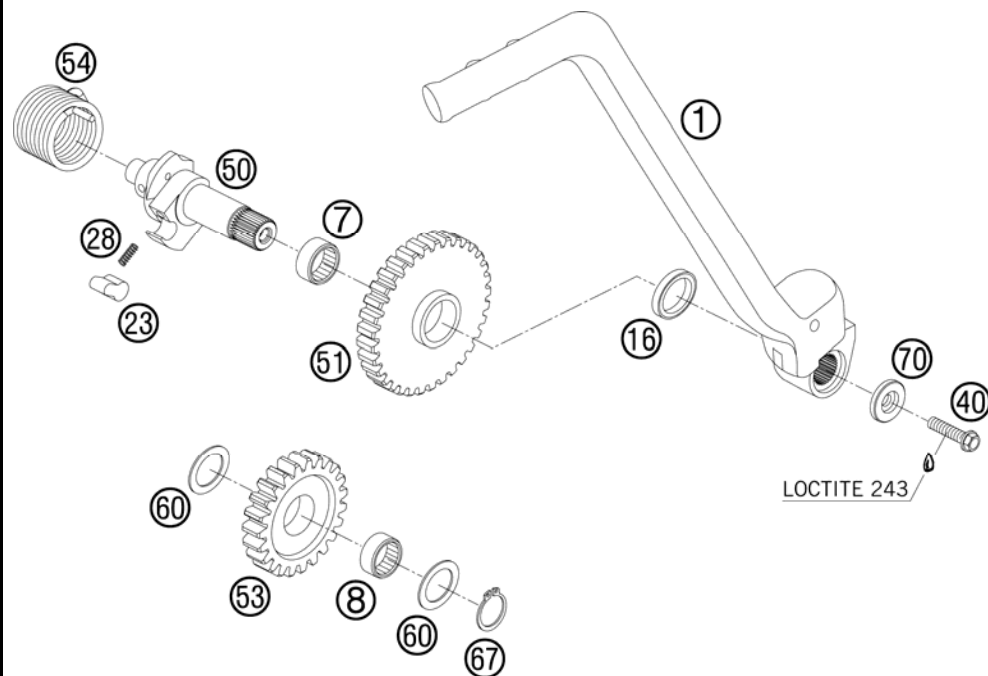

FIG	PART NUMBER	DESCRIPTION	QTY
1	80033070100	KICKSTARTER CPL. 2005	1
7	0405182210	NEEDLE BEARING K 18X22X10 02	1
8	0405172110	NEEDLE BEARING K 17X21X10	1
16	0760182442	SHAFT SEAL RING 18X24X4	1
23	80033023000	LOCKING PAWL KICK 03	1
28	80033028000	RATCHET SPRING 03	1
40	0015060253	HH COLLAR SCREW M 6X25 WS=8	1
50	80033050000	KICKSTARTER SHAFT 03	1
51	80033051000	KICKSTARTER GEAR 03	1
53	80033053000	INTERMEDIATE GEAR 03	1
54	80033054000	KICKSTARTER SPRING 03	1
60	54633090000	STOP DISK 17,2X25X1	2
67	0471170010	CIRCLIP DIN0471-17X1	1
70	80033070150	STEPPED WASHER KICKSTARTER	1

088003390 / C088003390

* NEW PART

X AS REQUIRED

SHIFTING MECHANISM

HUSABERG FE 450-E 2008

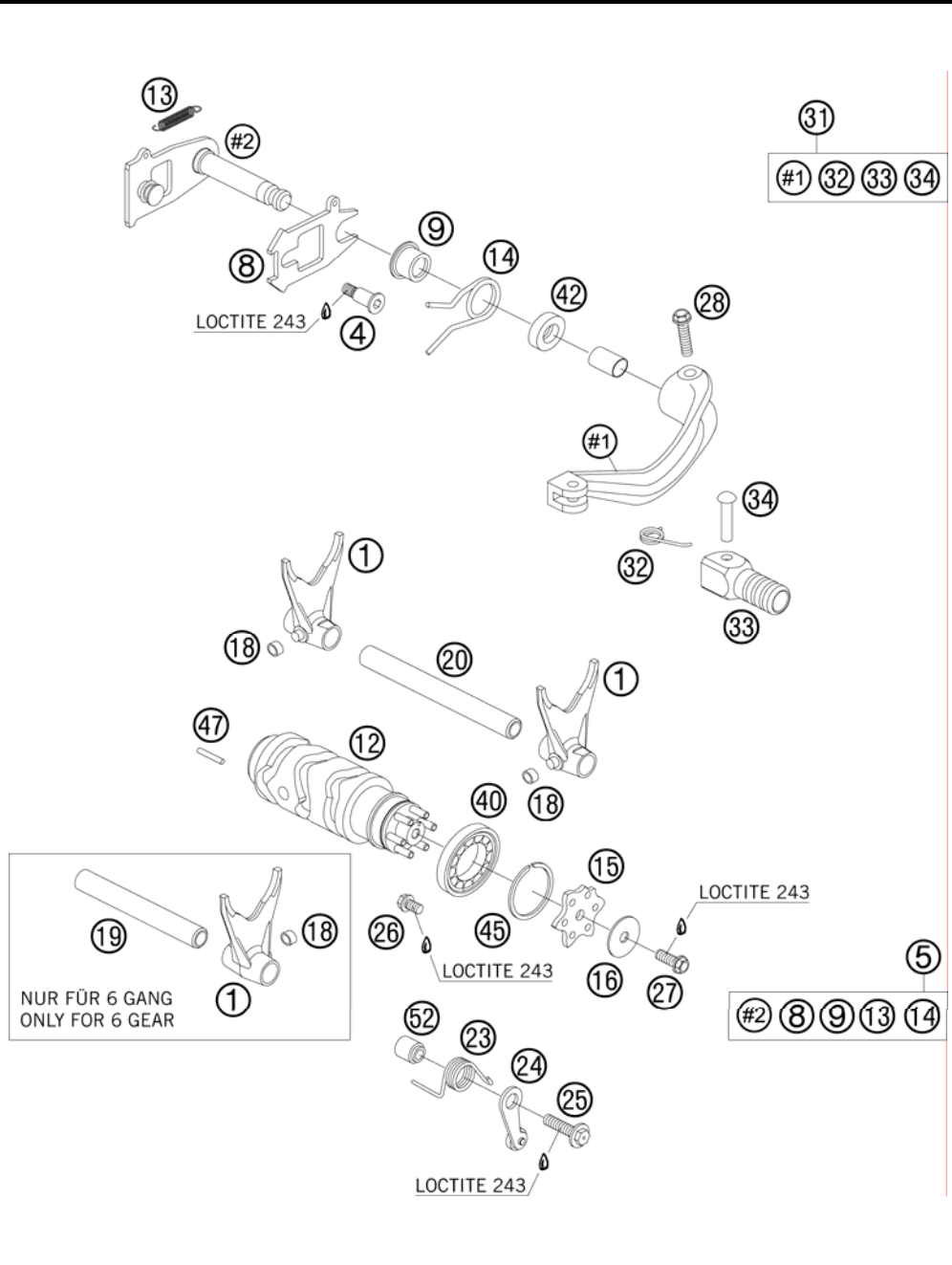

FIG	PART NUMBER	DESCRIPTION	QTY
1	80034001000	SHIFTING FORK	03 x
4	80034014050	SPECIAL SCREW RETAINING SPRING	1
5	80034005000	SHIFTING SHAFT CPL.	03 1
8	80034008000	SLIDING PLATE	03 1
9	80034009000	SPRING GUIDE	03 1
12	80034012000	SHIFTING DRUM	03 1
13	80034013000	TENSIONING SPRING	03 1
14	80034014000	RETAINING SPRING	03 1
15	80034015000	POSITIONING STAR	03 1
16	80034015150	WASHER POS. STAR 6,4X24X1,2	1
18	50334018100	SHIFTING ROLLER 6X8X5,2	x
19	80034019000	SHIFT RAIL MAIN SHAFT	03 1
20	80034020000	SHIFT RAIL COUNTERSHAFT	03 1
23	80034023000	SPRING FOR LOCKING LEVER	03 1
24	80034024000	LOCKING LEVER CPL.	03 1
25	80034024050	SPECIAL SCREW M 6X25	1
26	0015060103	HH COLLAR SCREW M 6X10 WS=8	1
27	0015060163	HH COLLAR SCREW M 6X16 WS=8	1
28	0015060253	HH COLLAR SCREW M 6X25 WS=8	1
31	80034031000	SHIFTING LEVER CPL.	03 1
32	54634032100	SHIFTING LEVER SPRING 250	1
33	54634131000	STEP PLATE FOR SHIFT LEVER 250	1
34	54634031050	BOLT 6X25 FOR SHIFT LEVER	1
40	0625068060	BALL BEARING 6806 C3	1
42	0760122270	SHAFT SEAL RING 12 X 22 X 7 B	1
45	80034012050	CIRCLIP SW30X1,5	1
47	0481030220	TENSION PIN DIN1481 3X22	1
52	80034052000	SLEEVE FOR LOCKING LEVER	03 1

088003410 / C088003410

* NEW PART

X AS REQUIRED



COOLING SYSTEM

HUSABERG FE 450-E 2008

HUSABERG FE

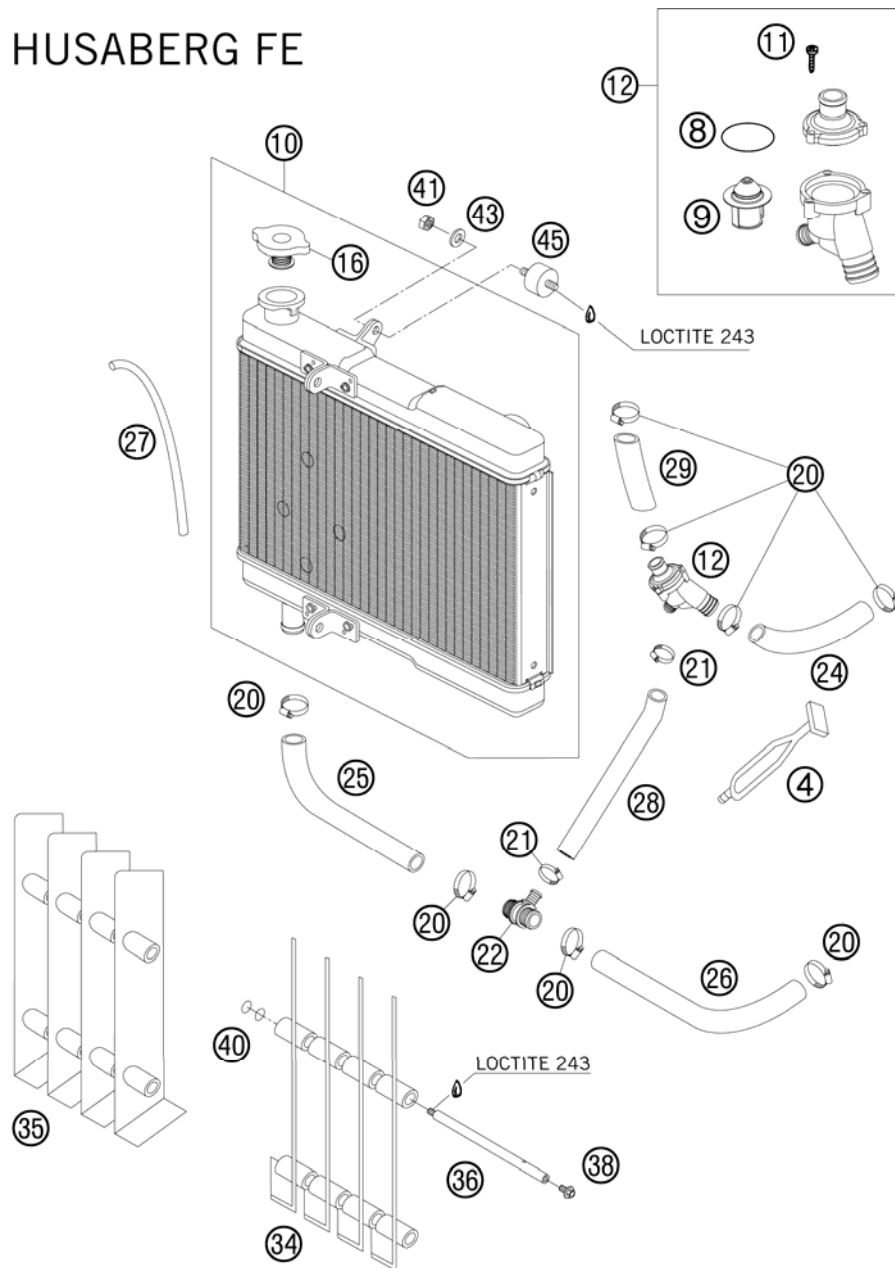

FIG	PART NUMBER	DESCRIPTION	QTY
4*	50303018000	RUBBER L=145MM	1
8	0770320020	O-RING 32,00X2,00	1
9	59435017000	THERMOSTAT 70 DEGREES 04	1
10	80035010100	RADIATOR "45493B" 2006	1
11	0016040183	SCREW FOR PLASTIC D=4X18	3
12	80035013044	THERMOSTAT CPL. 2005	1
16	58035016000	RADIATOR CAP SMALL 20,3 PSI	1
20	10001020000	HOSE CLAMP GEMI 16-27	8
21	58335099000	HOSE CLAMP GEMI 10-16	2
22	80035027004	T-CONNECTOR 05	1
24	81035024000	HOSE CYLINDER-THERMOST. 450 05	1
25	80035027002	HOSE 2 THERMOSTAT 05	1
26	80035027001	HOSE 1 THERMOSTAT 05	1
27	31007107001	PVC-HOSE 6X9 MM PER METER	x
28	80035027003	HOSE 3 THERMOSTAT 05	1
29	80035026000	HOSE THERMOSTAT- RADIATOR 05	1
34	80035034000	RADIATOR PROTECTOR L/S 04	4
35	80035035000	RADIATOR PROTECTOR R/S 04	4
36*	80035036100	MOUNTING BOLT RADIATOR PROTEC.	4
38	0014060103	HH COLLAR SCREW M 6X10 WS=8	2
40	0770010015	O-RING 10,00X1,50 NBR 70 SH	8
41	0985060003	SELF LOCK. NUT DIN0985-M 6	3
43	0021060003	WASHER DIN9021-A 6,4	3
45	80035005000	VIBRAT. DAMP. 25X15M6X10/15 04	3

088003530 / C088003530

* NEW PART

X AS REQUIRED

VALVE DRIVE

HUSABERG FE 450-E 2008



FIG	PART NUMBER	DESCRIPTION	QTY
27	59036027000	VALVE-STEM SEALING RACING	4
28	59436028044	VALVE SPRING CONICAL CPL. 03	4
30	59036030000	INTAKE VALVE D=35MM	2
31	59036031000	EXHAUST VALVE D=30MM	2
33	59036033000	VALVE COLLET KK 6 H	8
50	59036050000	DECOMPRESSION SHAFT CPL.	1
51	0770051016	O-RING 5,10X1,60 NBR 70	1
52	0912050083	AH SCREW DIN 912 M 5X8	2
53	59036060010	SHIM ALU 5,2X10X2	2
54	0770191016	O-RING 19,10X1,60 NBR 70	2
55	59036061095	END CAP ROCKER ARM SHAFT	2
56	59036056000	ROCKER ARM SHAFT INTAKE	1
57	59036057000	ROCKER ARM SHAFT EXHAUST	1
58	0471080000	CIRCLIP DIN0471- 8X0,8	1
59	59036059000	DECOMPRESSION LEVER SPRING	1
60	59036060144	ROCKER ARM INTAKE CPL.	1
61	59036061144	ROCKER ARM EXHAUST CPL.	1
62	59036062000	ADJUSTMENT SCREW M6X0,75	4
63	59036062100	NUT M6X0,75	4

088003610 / C088003610

* NEW PART

X AS REQUIRED

TIMING VALVE

HUSABERG FE 450-E 2008

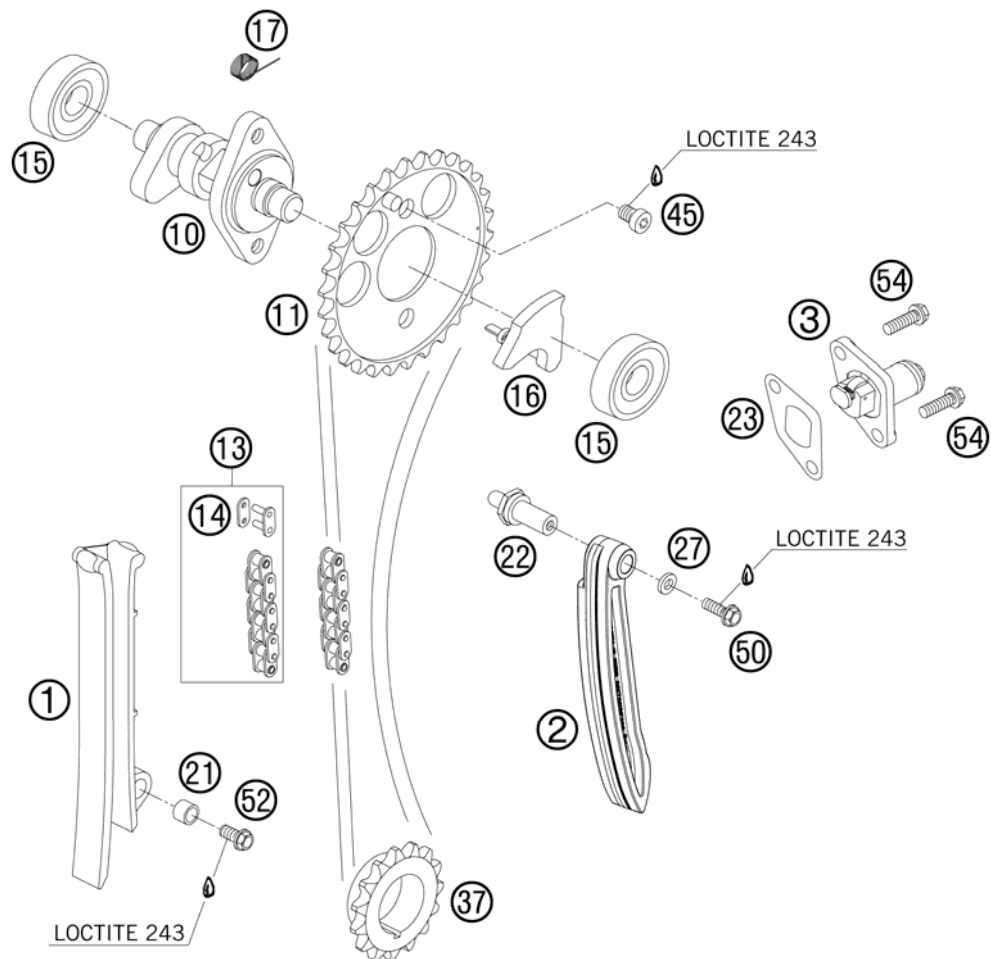

FIG	PART NUMBER	DESCRIPTION	QTY
1	80036001000	TIMING CHAIN GUIDE 04	1
2	80036002100	TENSIONER 450-550 05	1
3	59036003000	TIMINGCHAIN TENSIONER CPL.RAC.	1
10	80036010000	CAMSHAFT 450/501/550 03	1
11	80036011100	CAMSHAFT GEAR 05	1
13	81036013100	TIMING CHAIN 64L DID 05	1
14	80036013150	LINK FOR TIMING CHAIN DID 05 DID-CHAIN	1
15	0625062014	BALL BEARING 6201	2
16	59036016000	AUTO DECOMPRESSION SHAFT	1
17	59036017000	SPRING FOR AUTODECOMPRESSION	1
21	80036001050	SPACER BUSHING TIM.CH.GUIDE 04	1
22	80036002050	STEPPED SPACER BUSHING 04	1
23	59036003050	GASKET TIMING CHAIN TENSIONER	1
27	59036060010	SHIM ALU 5,2X10X2	1
37	80036037000	TIMING CHAIN GEAR 03	1
45	0984080103	AH SCREW DIN7984-M 8X10	2
50	0015050163	HH COLLAR SCREW M 5X16 WS=8	1
52	0015060123	HH COLLAR SCREW M 6X12 WS=8	1
54	0015060163	HH COLLAR SCREW M 6X16 WS=8	2

088003620 / C088003620

* NEW PART

X AS REQUIRED

CYLINDER HEAD

HUSABERG FE 450-E 2008

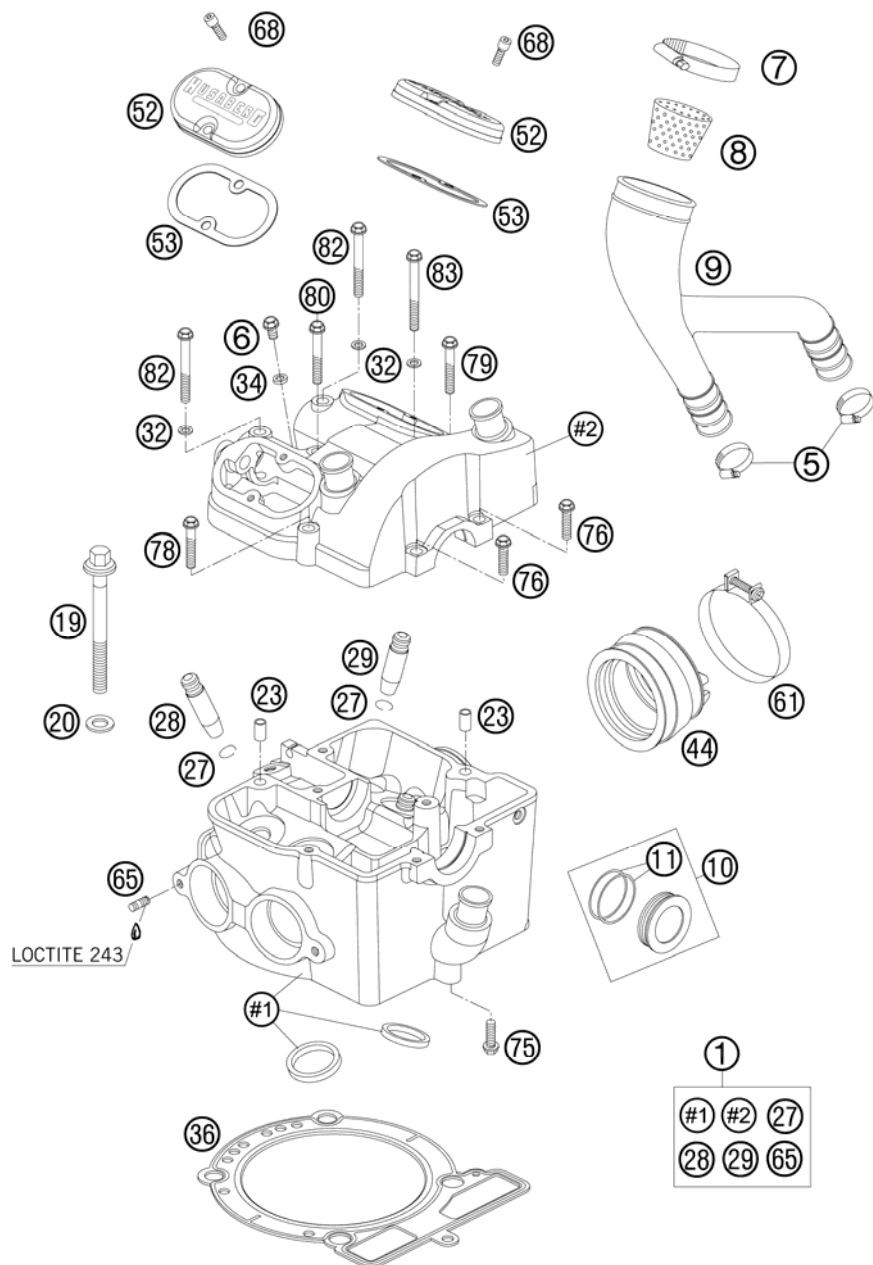

FIG	PART NUMBER	DESCRIPTION	QTY
1	80036020044	CYLINDER HEAD CPL. 04	1
5	10001020000	HOSE CLAMP GEMI 16-27	2
6	59036006090	VENT SCREW M6X10 CPL.	1
7	46005058000	HOSE CLAMP 40-60MM	1
8	80030089000	FILTER FOR BREATHER SYSTEM 04	1
9	80030090000	BREATHER HOSE ENGINE 04	1
10	80036010050	CLOSING COVER 03	1
11	0770291016	O-RING 29,10X1,60 NBR 70	2
19	58036099100	COLLAR SCREW M10X80 WS=13 10.9	4
20	59036090000	WASHER 10,8X18,8X1,5	4
23	59030023000	DOWEL 6X8X11,5	2
27	0993012000	CIRCLIP DIN7993-RW12	4
28	59036026101	VALVE GUIDE EXHAUST	2
29	59036025101	VALVE GUIDE INTAKE	2
32	0603061001	CU-SEAL RING DIN7603-6X10X1	3
34	58036065100	CU-SEAL RING 6 X 10 X 2	1
36	81030036000	CYLINDER HEAD GASKET 03	1
44	80036044000	INTAKE BOOD 450/501/550 04	1
52	80036052000	VALVE COVER 03	2
53	80036053000	GASKET FOR VALVE COVER 03	2
61	59030061000	CLAMP D=56MM B=9MM M4X25	2
65	0939060163	STUD DIN939-M 6X16	2
68	0912050163	AH SCREW DIN0912-M 5X16	4
75	0015060203	HH COLLAR SCREW M 6X20 WS=8	1
76	0015060253	HH COLLAR SCREW M 6X25 WS=8	2
78	0015060353	HH COLLAR SCREW M 6X35 WS=8	1
79	0015060403	HH COLLAR SCREW M 6X40 WS=8	1
80	0015060453	HH COLLAR SCREW M 6X45 WS=8	1
82	0015060556	HH COLLAR SCR. M6X55 WS=8 10.9	2
83	0015060603	HH COLLAR SCREW M 6X60 WS=8	1

088003630 / C088003630

* NEW PART

X AS REQUIRED

LUBRICATING SYSTEM

HUSABERG FE 450-E 2008

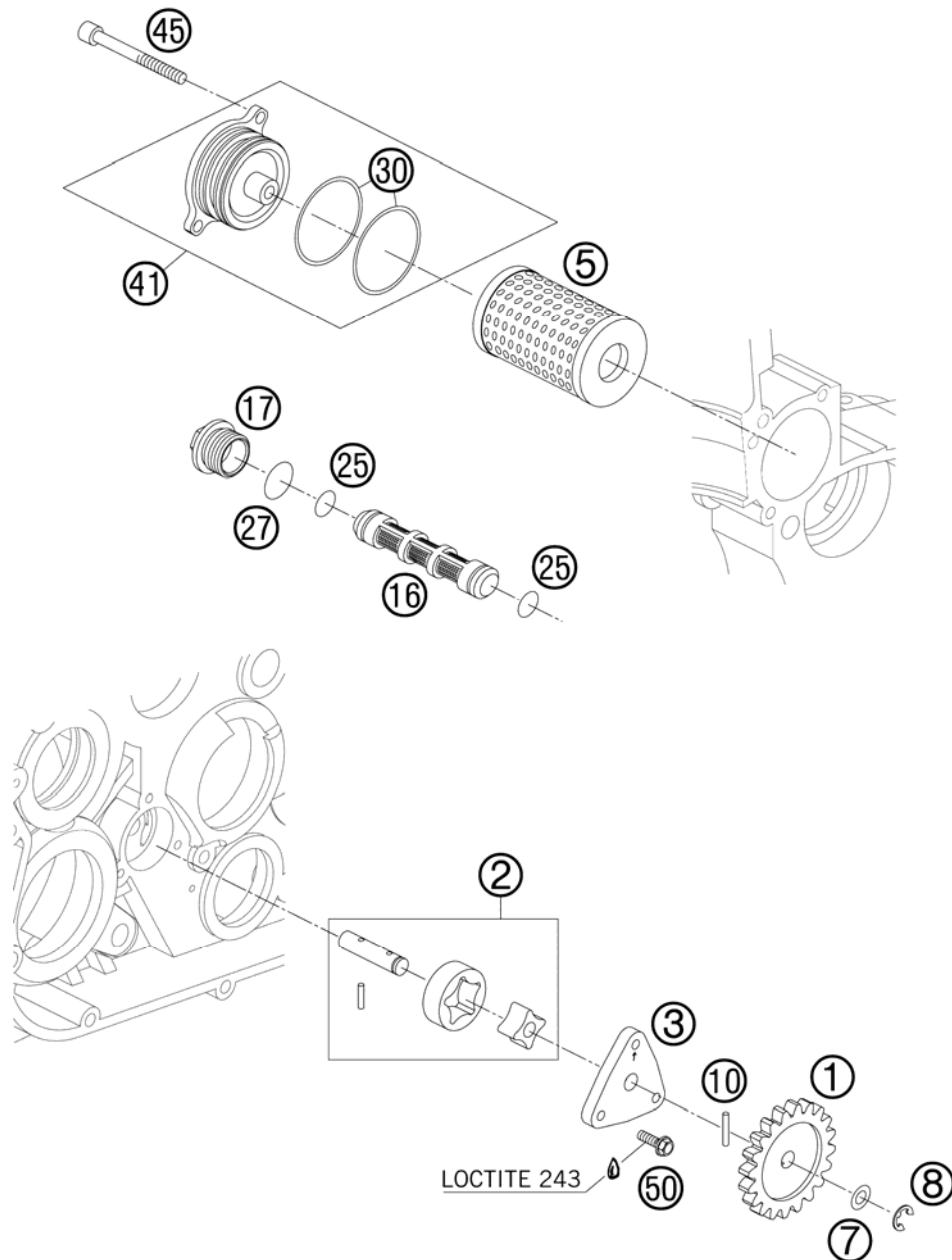

FIG	PART NUMBER	DESCRIPTION	QTY
1	80038001000	OIL PUMP GEAR 03	1
2	80038002044	OIL PUMP CPL. 03	1
3	80038003000	OIL PUMP COVER 03	1
5	58038005100	OIL FILTER LONG	1
7	58038007755	STOP DISK 8,1 X 15 X 0,5	1
8	0799060000	TAB WASHER DIN6799-RS 6,0	1
10	0402251980	NEEDLEROL.DIN5402 NRA 2,5X19,8	1
16	59038016000	OIL SCREEN 15X83MM	1
17	59038017000	PLUG M20X1,5 WS=13	1
25	0770125015	O-RING 12,5X1,5 NBR	2
27	0770020170	O-RING 17,17X1,78 GLO	1
30	0770380020	O-RING 38,00X2,00 NBR 70 SH	2
41	80038041000	OIL FILTER COVER 03	1
45	0912050503	AH SCREW DIN912-M5X50 10.9	2
50	0016040133	HH COLLAR SCREW M 4X13 WS=6	3

088003810 / C088003810

* NEW PART

X AS REQUIRED

IGNITION SYSTEM

HUSABERG FE 450-E 2008

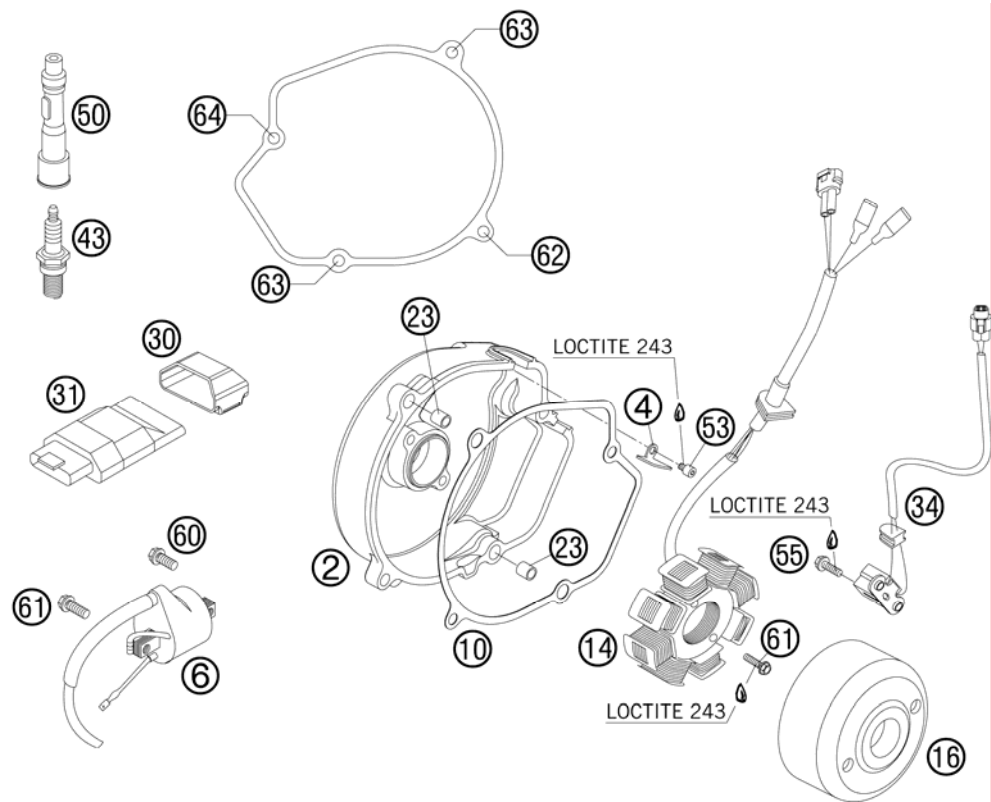

FIG	PART NUMBER	DESCRIPTION	QTY
2	80030002100	IGNITION COVER ALU 04	1
4	80039002050	SUPPORT FOR STATOR WIRE 04	1
6	50339006000	IGNI.COIL KOKU. IG5127	1
10	80030040100	IGNITION COVER GASKET 04	1
14	80039004000	STATOR HUSABERG FS/FE 04	1
16	80039005000	FLYWHEEL HUSABERG FS/FE 04	1
23	59030023000	DOWEL 6X8X11,5	2
30	80039030100	RUBBER HOLDER FOR CDI 05	1
31	81039031100	CDI UNIT 450 05	1
34	59039034000	PULSER COIL KOKUSAN 4K3-A/B	1
43	59039093100	SPARK PLUG NGK DCPR8E 03	1
50	58439090000	SPARK PLUG CONNECT. SD05EG 03	1
53	0912060083	AH SCREW DIN0912-M 6X 8	1
55	0015050163	HH COLLAR SCREW M 5X16 WS=8	2
60	0015060163	HH COLLAR SCREW M 6X16 WS=8	1
61	0015060203	HH COLLAR SCREW M 6X20 WS=8	x
62	0015060253	HH COLLAR SCREW M 6X25 WS=8	1
63	0015060303	HH COLLAR SCREW M 6X30 SW=8	2
64	0015060353	HH COLLAR SCREW M 6X35 WS=8	1

088003910 / C088003910

* NEW PART

X AS REQUIRED

ELECTRIC STARTER

HUSABERG FE 450-E 2008

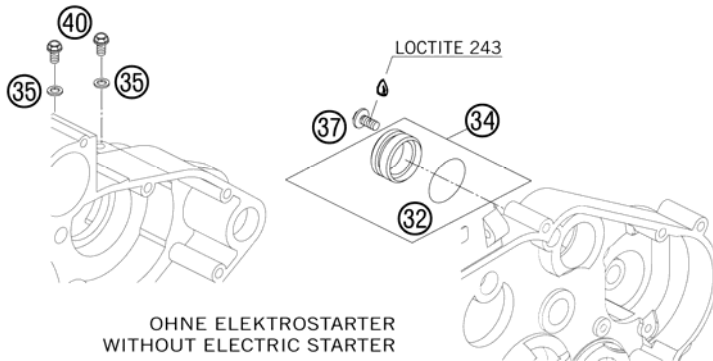
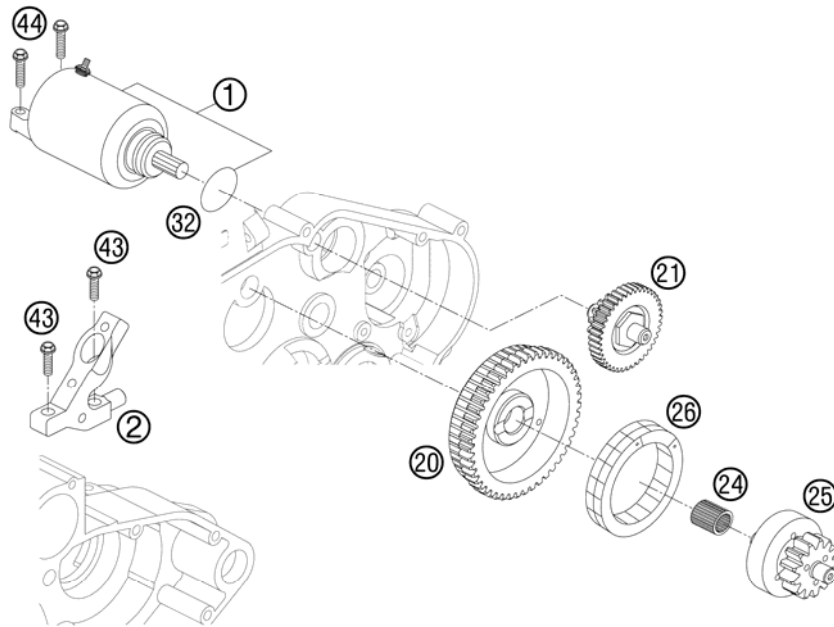

OHNE ELEKTROSTARTER
WITHOUT ELECTRIC STARTER

FIG	PART NUMBER	DESCRIPTION	QTY
1	80040001000	E-STARTER ENGINE CPL. 03	1
2	81040002000	BRACKET ELEC. STARTER ENG. 04	1
20	80040020000	FREE WHEEL GEAR 03	1
21	80040021100	GEAR WHEEL TORQUE LIMITER 04	1
24	0405101310	NEEDLE BEARING K 10X13X10 02	1
25	80040025000	FREE WHEEL HUB 03	1
26	80040026000	FREE WHEEL 03	1
32	0770242030	O-RING 24,20X3,00 NBR70	1
34	80040034100	PLUG ELECTRIC STARTER 04	1
35	0603061001	CU-SEAL RING DIN7603-6X10X1	2
37	0014060103	HH COLLAR SCREW M 6X10 WS=8	1
40	0015060103	HH COLLAR SCREW M 6X10 WS=8	2
43	0015060203	HH COLLAR SCREW M 6X20 WS=8	2
44	0015060253	HH COLLAR SCREW M 6X25 WS=8	2

088004010 / C088004010

* NEW PART

X AS REQUIRED

NOTICE

HUSABERG FE 450-E 2008

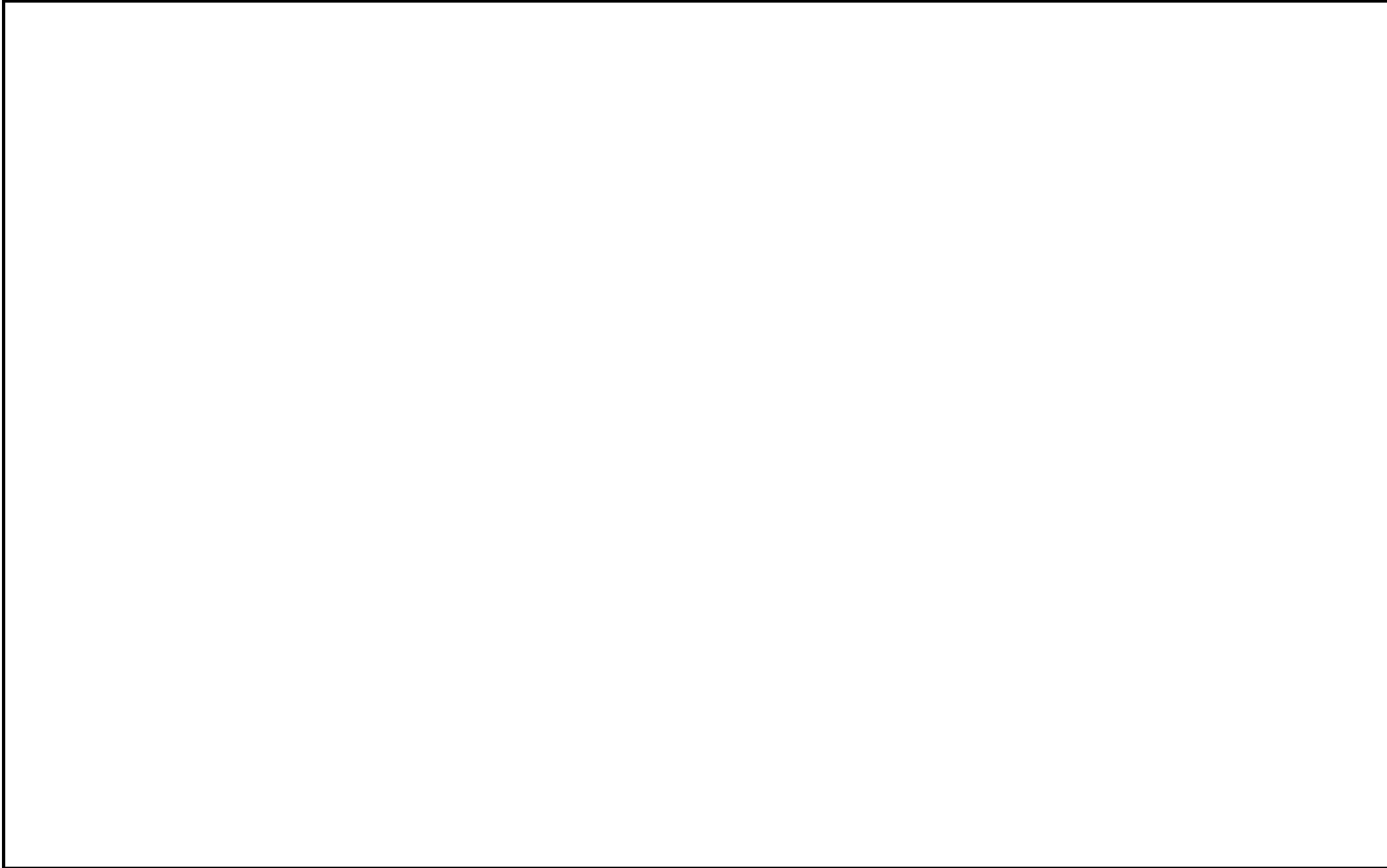

NOTICE

HUSABERG FE 450-E 2008



NOTICE

HUSABERG FE 450-E 2008





HUSABERG – a company of the KTM Group
A-5230 Mattighofen
www.husaberg.cc



3CM090021HEN



Art.Nr.: 3CM090021HEN 6/2007