

Owner's manual

***MULTISTRADA***

***MULTISTRADA 1200***



***MULTISTRADA***

***MULTISTRADA 1200***



We would like to welcome you among Ducati enthusiasts, and congratulate you on your excellent choice of motorcycle. We think you will ride your Ducati motorcycle for long journeys as well as short daily trips. Ducati Motor Holding S.p.A. wishes you smooth and enjoyable riding.

We are continuously working to improve our Technical Assistance service. For this reason, we recommend that you strictly follow the instructions in this manual, especially those regarding the running-in period. In this way, you can be sure your Ducati motorcycle will continue to be a pleasure to ride.

For repairs or advice, please contact one of our authorised service centres.

We also provide an information service for all Ducati owners and enthusiasts for any advice and suggestions you might need.

Enjoy the ride!



## Note

Ducati Motor Holding S.p.A. cannot accept any liability for errors that may have occurred in the preparation of this manual. All information in this manual is valid at the time of going to print. Ducati Motor Holding S.p.A. reserves the right to make any modifications required due to the ongoing development of their products.

For your safety, as well as to preserve the warranty, reliability and worth of your motorcycle, use original Ducati spare parts only.



## Warning

This manual forms an integral part of the motorcycle and - if the motorcycle is resold - must always be handed over to the new owner.

# E Table of contents

## General Indications 7

- Warranty 7
- Symbols 7
- Useful road safety information 8
- Riding with a full load 9
- Identification data 11

## Instrument panel (Dashboard) 12

- Instrument panel 12
- LCD unit functions 14
- LCD - Parameter setting/display 15
- Vehicle speed indicator 16
- Engine rpm indicator (RPM) 17
- Engaged gear indicator 18
- Clock 19
- Fuel level indicator 20
- Coolant temperature 21
- Total distance covered indicator: "Odometer" 22
- "Trip 1" meter 23

- "Trip 2" meter 23
- Indication if the DTC function is active/not active 24
- Indication if the LAP function is active/not active 24
- Warning indication (Alarms/Signals) 25
- "Low" battery level 26
- Traction Control (DTC) deactivated 26
- Hands Free key (HF) not recognised 27
- "Low" Hands Free key (HF) battery level 27
- "High" engine coolant temperature 28
- Steering release error - Steering still locked 28
- Instrument panel diagnostics 29
- Service indicator 33
- Residual range indication when the SERVICE is due 33
- Indication of range reached for SERVICE 33
- Maintenance table 34
- SET UP - "Riding Mode set" indication 36
- "RANGE" indicator - remaining range 37
- Indicator "CONS I." - Instantaneous fuel consumption 38
- Indicator "CONS M." - Average fuel consumption 38
- Indicator "AVG" - Average speed 39
- Air temperature indicator 39
- Indicator "TIME TRIP" - Trip time 41
- "Riding Mode" function (riding mode change) 42
- "Setting" menu 44
- Battery voltage indicator (BATTERY) 46
- "Riding Mode" customisation 48
- DTC (Ducati Traction Control) setting function 50
- ENGINE setting function (Engine Power Control) 54
- DEFAULT function (Resetting Ducati default parameters) 56
- Instrument panel backlighting adjustment function 58
- LAP Activation/Deactivation function (lap time) 60
- LAP registration function 62

Stored LAP display function	64
DTC (Ducati Traction Control) on/off function	66
Digital RPM indication function	68
Clock setting function	70
The immobilizer system	72
Keys	72
Replacing the battery in the active key	74
Duplicate keys	77
Immobilizer override procedure	78
Light control	84
Units of measurement modification	89
<b>Controls</b>	<b>92</b>
Position of motorcycle controls	92
“Hands free” system	93
Lh switch	104
Clutch lever	105
RH switch	106
Throttle twistgrip	107
Front brake lever	107
Rear brake pedal	108
Gear change pedal	108
Adjusting the position of the gearchange and rear brake pedals	109
<b>Main components and devices</b>	<b>111</b>
Position on the vehicle	111
Tank filler plug	112
Seat lock	113

Helmet cable	116
Side stand	117
Power outlet	118
Adjusting the front fork	119
Adjusting the rear shock absorber	120

## Riding the motorcycle 122

Running-in recommendations	122
Pre-ride checks	124
Engine on/off	125
Moving off	127
Braking	127
Stopping the motorcycle	128
Parking	128
Refuelling	131
Tool kit and accessories	132
Front semi-mudguard kit	132
Long rear mudguard kit	134

## Main maintenance operations 135

Checking and topping up coolant level	135
Checking brake and clutch fluid level	136
Checking brake pads for wear	138
Lubricating cables and linkages	139
Adjusting throttle control free play	140
Charging the battery	141
Checking drive chain tension	142
Lubricating the drive chain	143
Use of the supplied chain tensioning gauge	144

Replacing the high and low beam bulbs 146  
Rear turn indicators 148  
Number plate light 149  
Beam setting 149  
Rear-view mirror adjustment 151  
Tubeless tyres 152  
Checking engine oil level 154  
Cleaning and replacing the spark plugs 155  
General cleaning 156  
Storing the motorcycle 157  
Important notes 157

## Scheduled maintenance chart 158

Operations to be carried out by the dealer 158  
Operations to be carried out by the dealer 160  
Operations to be carried out by the customer 161

## Technical data 162

Overall dimensions (mm) 162  
Weights 162  
Engine 164  
Timing system 164  
Performance data 165  
Spark plugs 165  
Fuel system 165  
Brakes 166  
Transmission 167  
Frame 168  
Wheels 168

Tyres 168  
Suspension 168  
Exhaust system 169  
Colour schemes 169  
Electrical system 169

## Routine maintenance record 175

For United States of America version  
Only 176

## Routine maintenance record 186

# General Indications

## Warranty

In your own interest, and in order to guarantee product reliability, you are strongly advised to refer to our authorised Dealers and Service Centers for any servicing requiring particular technical expertise.

Our highly skilled staff have the tools required to perform any servicing job to the highest professional standards, using only Ducati original spare parts to ensure full interchangeability, smooth running and long life.

All Ducati motorcycles come with a Warranty Booklet. The warranty does not apply to motorcycles used in competitions or in cases where there is evidence of poor maintenance. If any motorcycle part is tampered with, modified, or replaced with parts other than original Ducati spare parts during the warranty period, the warranty is automatically invalidated.

## Symbols

Ducati Motor Holding S.p.A. advises you to read this manual carefully in order to familiarise yourself with your motorcycle. If in doubt, please contact a Ducati Dealer or Authorised Service Centre. The information contained herein will prove useful on your trips - and Ducati Motor Holding S.p.A. wishes you smooth, enjoyable riding - and will help you keep the performance of your motorcycle unchanged for a long time. This booklet uses a set of symbols with special meanings:



### Warning

Failure to comply with these instructions may put you at risk, and could lead to severe injury or even death.



### Important

Risk of damage to the motorcycle and/or its components.



### Note

Additional information about the current operation.

The terms RIGHT and LEFT are referred to the motorcycle viewed from the riding position.



## Useful road safety information



### Warning

Read this section before riding your motorcycle.

Many accidents are the result of the inexperience of the rider. Always make sure you have your licence with you; you need a valid licence that entitles you to ride a motorcycle.

Do not lend your motorcycle to persons who are inexperienced or do not hold a valid licence.

Both rider and pillion passenger must ALWAYS wear a safety helmet.

Do not wear loose clothes or accessories that could become tangled in the controls or limit your field of vision.

Never start or run the engine indoors. Exhaust gases are toxic and may lead to loss of consciousness or even death within a short time.

The rider should keep his/her feet on the footrests when the motorcycle is in motion.

ALWAYS hold the handlebars firmly with both hands so you will be ready for sudden changes of direction or in the road surface. The pillion passenger should ALWAYS hold on to the special handles onto tail guard with both hands.

Ride within the law and observe national and local rules.

ALWAYS respect speed limits where these are posted.

However, ALWAYS adjust your speed to the visibility, road and traffic conditions you are riding in.

ALWAYS signal your intention to turn or pull to the next lane in good time using the suitable turn indicators.

Be sure you are clearly visible and do not ride within the blind spot of vehicles ahead.

Be very careful at road junctions, or when riding in areas near exits from private land or car parks, or on the slip roads to motorways.

ALWAYS turn off the engine when refuelling.

Be extremely careful not to spill fuel on the engine or on the exhaust pipe when refuelling.

Do not smoke when refuelling.

While refuelling, it is possible to inhale noxious fuel vapours.

Should any fuel drops be spilled on your skin or clothing, immediately wash with soap and water and change your clothing.

ALWAYS remove the key when you leave your motorcycle unattended.

The engine, exhaust pipes and silencers remain hot for a long time.



### Warning

The exhaust system might be hot, even after engine is switched off; pay particular attention not to touch exhaust system with any body part and do not park the vehicle next to inflammable material (wood, leaves etc.).

Park your motorcycle where no one is likely to knock against it, and use the sidestand.

Never park on uneven or soft ground or your motorcycle may fall over.

## Riding with a full load

Your motorcycle is designed for travelling over long distances with a full load in complete safety.

Even weight distribution is critical for maintaining safety standards, and to avoid getting into difficulties when making sudden manoeuvres or riding on bumpy roads.



### Warning

The maximum speed permitted with the side panniers, top case and the tank bag fitted must not exceed 180 km/h.



### Warning

Do not exceed the total permitted weight for the motorcycle and pay attention to information provided below regarding load capacity.

## Information on load capacity

The total weight of the motorcycle in running order including rider, passenger, luggage and additional accessories should not exceed:

430 kg.

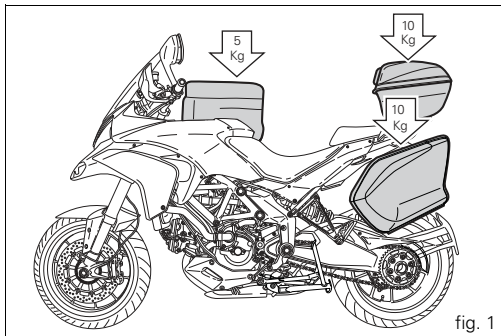

### Warning

The total weight permitted for the side panniers, top case and the tank bag must never exceed 35 kg, divided as follows:

10 kg max. per side pannier;

10 kg max for the top case;

5 kg max. for the tank bag.



## Important

Arrange your luggage or heavy accessories in the lowest possible position and close to motorcycle centre.

Secure the luggage firmly to the motorcycle structure.

Improperly secured luggage may affect stability.

Never attach bulky or heavy objects to the steering head or

front mudguard, as this would cause dangerous instability.

Do not insert objects into gaps in the frame, where they could interfere with moving parts.

If the side panniers are fitted (available upon request from the Ducati spare parts service), divide the baggage and accessories based on their weight and place them uniformly inside the side panniers. Lock both side panniers using the suitable key lock.

Make sure the tyres are inflated to the proper pressure indicated at page 152 and that they are in good condition.

## Identification data

All Ducati motorcycles have two identification numbers, for frame (fig. 2) and engine (fig. 3).

---

Frame number

---

---

Engine number

---



### Note

These numbers identify the motorcycle model and should always be indicated when ordering spare parts.

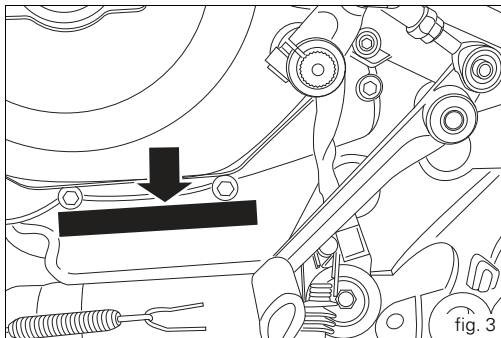
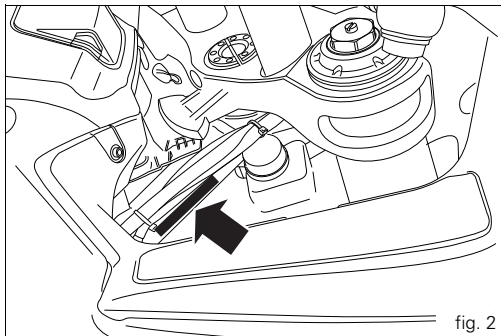

# E Instrument panel (Dashboard)

## Instrument panel

- 1) LCD Dot-Matrix, (see page 14)
- 2) REVOLUTION COUNTER (rpm).

Indicates engine revs per minute.

- 3) Neutral light N (green).

Illuminates when the gearbox is in neutral.

- 4) HIGH BEAM LIGHT  (BLUE).

It turns on to indicate that the high beam lights are on.

- 5) ENGINE OIL PRESSURE LIGHT  (RED).

Illuminates when engine oil pressure is too low. It must turn on at Key-On, but must turn off a few seconds after the engine has started.

It may come on briefly if the engine is very hot, but should go out again as engine speed increases.

### Important

If this light (5) stays on, stop the engine or it may suffer severe damage.

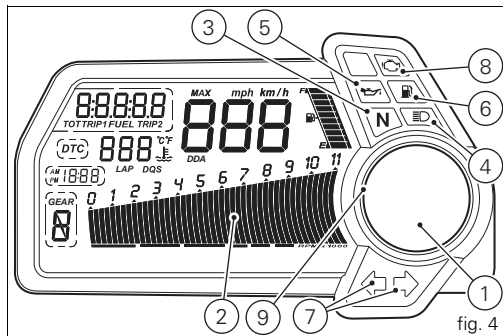



fig. 4

- 6) FUEL WARNING LIGHT  (AMBER).

Comes on when fuel is low and there are about 4 litres of fuel left in the tank.

- 7) TURN INDICATOR LIGHTS  (GREEN).

Illuminates and flashes when the turn indicator is in operation.

- 8) "ENGINE/VEHICLE DIAGNOSIS - EOBDD" LIGHT  (AMBER YELLOW).

It turns on in the case of "engine" and/or "vehicle" errors and in some cases will lock the engine.

- 9) Limiter light “Over rev”/ traction control light “DTC” (RED) (fig. 4):

	<b>Over rev light</b>
No limiter	Off
1st threshold - no. RPM before the limiter threshold (*)	On - STEADY
Rev limiter (limiter engaged due to overrevving) (*)	On - Flashing

	<b>DTC intervention lights</b>
No intervention	Off
DTC intervention	On - STEADY

(\*) depending on the model, each calibration of the Engine Control Unit may have a different “setting” for the thresholds that precede the rev limiter and the rev limiter itself.



### Note

If the Over rev function light and the DTC intervention light should both come on at the same time, the instrument panel gives priority to the Over rev function.

- 10) CONTROL SWITCH (fig. 5)

Button used to display and set instrument panel parameters with the position “▲”.

- 11) CONTROL SWITCH (fig. 5)

Button used to display and set instrument panel parameters with the position “▼”.

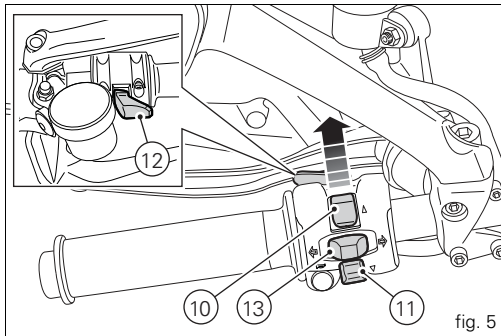

fig. 5

- 12) HIGH-BEAM FLASH BUTTON FLASH (fig. 5)

The high-beam flash button may also be used to for LAP functions.

- 13) RESET BUTTON (fig. 5).

The turn indicators off button may also be used for the RESET/CONFIRM function on the instrument panel and for activating the “Riding Style”.

## LCD unit functions

### Warning

Any adjustments to the instrument panel must only be carried out when the motorcycle is stationary. Never operate the instrument panel controls while riding the motorcycle.

#### 1) SPEEDOMETER.

Gives road speed

#### 2) ODOMETER.

Shows total distance travelled.

#### 3) TRIP METER.

Indicates distance travelled since the meters (TRIP 1 and TRIP 2) were last reset.

#### 4) CLOCK.

#### 5) FUEL LEVEL.

#### 6) ENGINE RPM INDICATOR (RPM).

#### 7) LAP TIME, MAXIMUM SPEED AND MAXIMUM RPM RECORDING (LAP).

#### 8) DTC INDICATOR ACTIVE/NOT ACTIVE.

#### 9) GEAR INDICATOR.

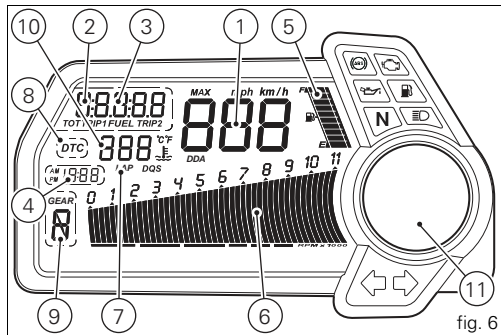

fig. 6

#### 10) WATER TEMPERATURE INDICATOR.

This function indicates engine coolant temperature.

### Important

Stop riding if the temperature reaches the maximum value, otherwise the engine might be damaged.

#### 11) LCD Dot-Matrix

## LCD - Parameter setting/display

At the end of the check, the instrument panel always displays the Odometer (TOT) as the "main" indicator on the main display and the "riding mode" on the round display.



### Note

The check can be interrupted by pressing the button (1, fig. 8).

At the end of the initial check, the instrument panel will always show the "main" display that indicates the following information.

On the main LCD (A, fig. 7):

- Vehicle speed indication;
- Engine rpm indication (RPM);
- Gear indication;
- Clock indication;
- Fuel level indication
- Coolant temperature indication;
- TOT - Odometer

At this point, by pressing the (1, fig. 8) "▲" switch it is possible to switch to the following functions:

- TRIP1 - Trip meter 1
- TRIP2 - Trip meter 2

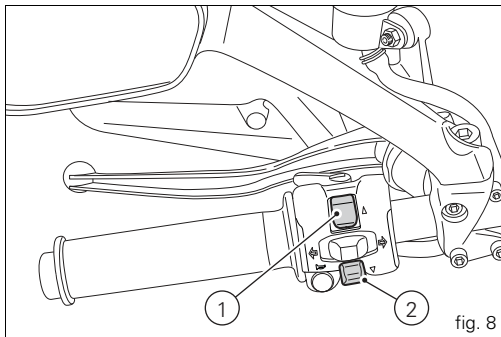
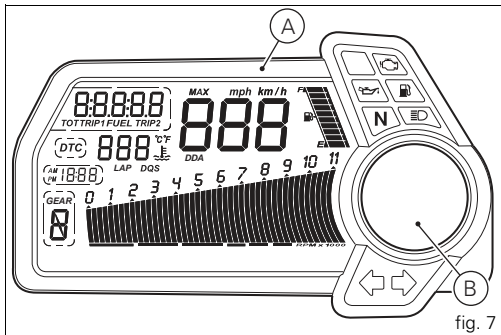



E LCD Dot-Matrix (B, fig. 7):

- WARNING (only if active)
- ERRORS (only if active)
- DESMO SERVICE (only if active)
- SET UP - "Riding Mode" indication set

At this point, by pressing the (2, fig. 8) "▼" button it is possible to switch to the following functions:

- RANGE - Remaining range
- CONS I. - Current fuel consumption
- CONS M. - Average fuel consumption
- AVG - Average speed
- AIR - Air temperature
- TIME TRIP - Trip time

## Vehicle speed indicator

This function displays vehicle speed (Km/h or mph depending on the set measurement system).

The instrument panel receives information about the actual speed (calculated in km/h) and displays the number increased by 8%.

Maximum speed displayed is 299 km/h (186 mph).  
Over 299 km/h (186 mph) a series of dashes will be displayed "----" (not flashing).

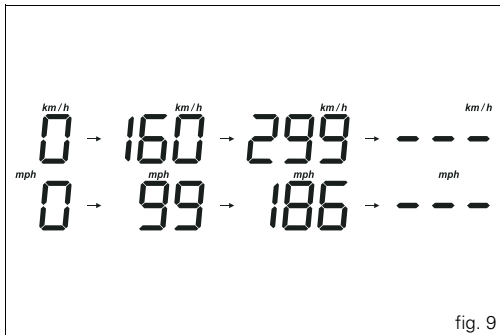

fig. 9

## Engine rpm indicator (RPM)

This function displays the rpms.

The instrument panel receives the engine rpm information and displays it.

This information is displayed progressively from the left to the right, identifying the rpms.

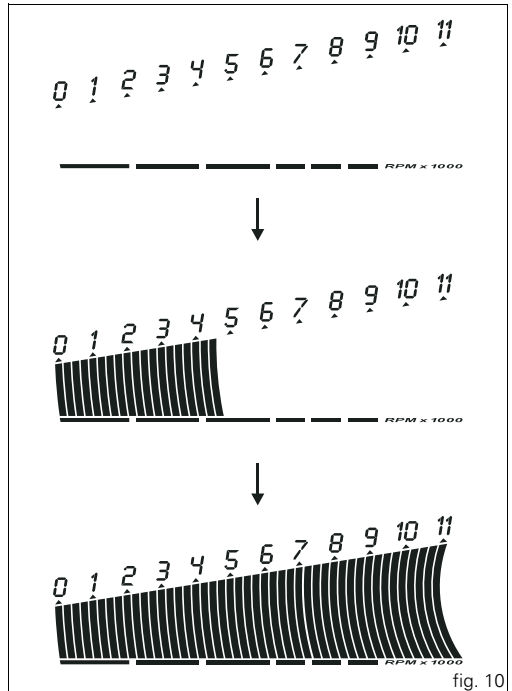

fig. 10

# E

## Engaged gear indicator

This function displays the gears.

The instrument panel receives information and indicates the engaged gear or "N" for neutral.



### Note

In the case of a gear sensor "error", a dash "-" (not flashing) will be displayed.

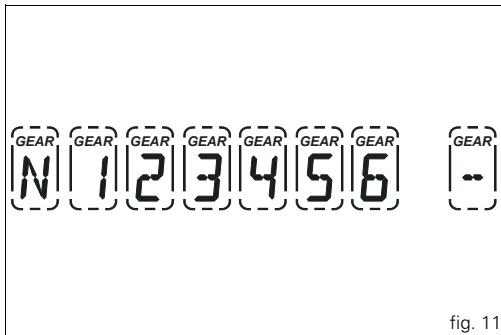

fig. 11

## Clock

This function shows the time.

Time is always displayed as follows:

AM from 0:00 to 11:59

PM from 12:00 to 11:59

If battery power is suddenly cut off (Batt-OFF), when battery power is restored and at the next Key-On, the clock is reset and restarts from "0:00".

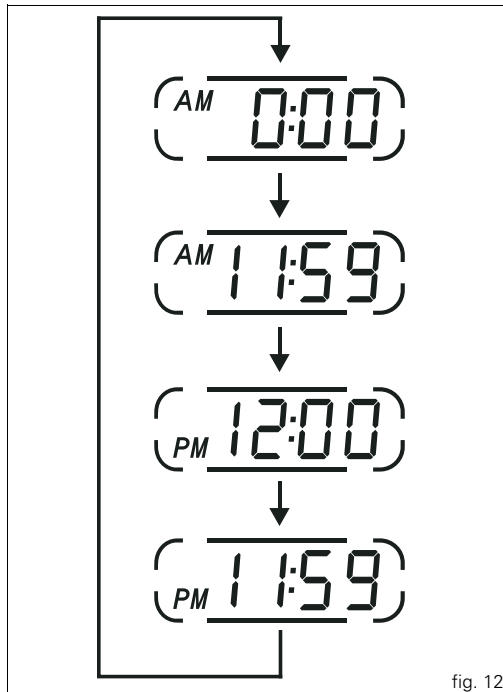

fig. 12

## Fuel level indicator

This function displays the fuel level.

The low fuel light turns on when the level goes down to 2 marks and there are still 4 litres in the tank; if the level goes down further, the last mark will be displayed flashing.

### Important

If the vehicle enters the reserve status and the light has turned on, it is recommended to turn the vehicle off when refuelling (Key-Off); if fuel is added without turning it off (Key-On and engine off) the data update may not be immediate.

### Note

In the case of a level sensor "error", the bargraph without marks is displayed and the rest of the digit will flash.

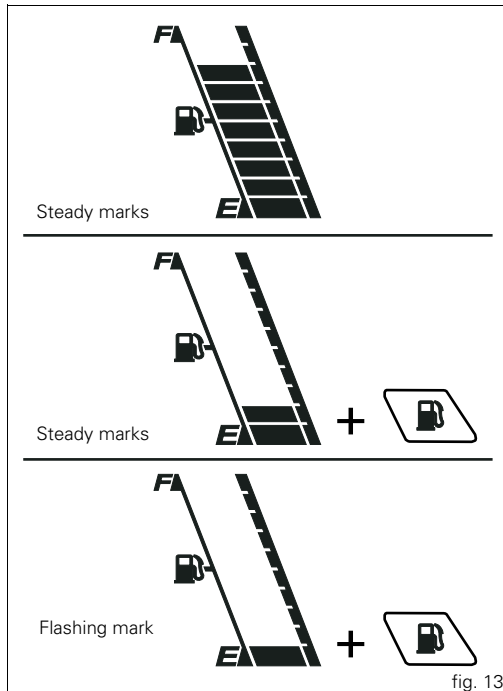

fig. 13

## Coolant temperature

This function indicates coolant indication state.

The temperature unit of measure can be selected (°C or °F).

The reading is indicated as follows:

- if the reading is between -39°C and +39°C "LO" is shown flashing on the instrument panel (steady);
- if the reading is between +40°C and +120°C it appears on the instrument panel (steady);
- if reading is +121 °C or higher, "HI" is shown flashing on the instrument panel;



### Note

In the event of a sensor "error", a string of flashing dashes ("—") is shown and the "Engine/vehicle diagnosis - EOBD" light (8, fig. 4) comes on.

EU, CND, FRA, JAP versions

Steady reading

LO °C

Steady reading

40 °C



Steady reading

120 °C

Flashing reading

HI °C

Flashing reading

— — — °C



Engine Diagnosis

UK, USA versions

Steady reading

LO °F

Steady reading

104 °F



Steady reading

248 °F

Flashing reading

HI °F

Flashing reading

— — — °F



Engine Diagnosis

fig. 14

## E Total distance covered indicator: "Odometer"

This function shows the total distance covered by the vehicle.

At Key-On the system automatically enters this function.

The odometer reading is stored permanently and cannot be reset.

If the distance travelled exceeds 99999 km (or 99999 miles), the value "99999" will be displayed permanently.

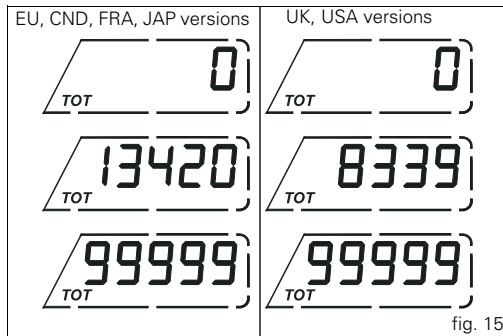

## “Trip 1” meter

This function shows the distance travelled since the trip meter was last reset.

Holding the button (1, fig. 8) “▲” pressed for 3 seconds when this function is displayed resets the trip meter.

If the reading exceeds 999.9, it is reset to zero and the count restarts automatically.

If the system measurement units are changed at any moment, or if there is an interruption in the power supply (Battery Off), the distance travelled is reset and the count starts from zero (considering the newly set unit of measurement).



### Note

When this value is reset, also the “Average fuel consumption”, “Average speed” and “Trip time” functions are reset.

## “Trip 2” meter

This function shows the distance travelled since the trip meter was last reset.

Holding the button (1, fig. 8) “▲” pressed for 3 seconds when this function is displayed resets the trip meter.

If the reading exceeds 999.9, it is reset to zero and the count restarts automatically.

If the system measurement units are changed at any moment, or if there is an interruption in the power supply (Battery Off), the distance travelled is reset and the count starts from zero (considering the newly set unit of measurement).

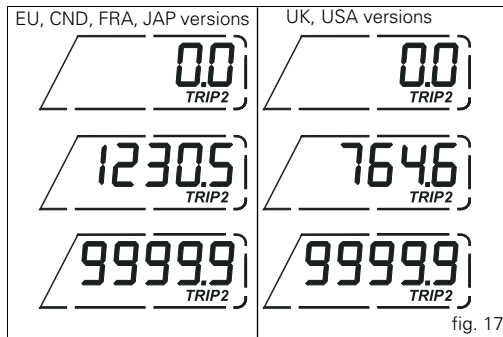
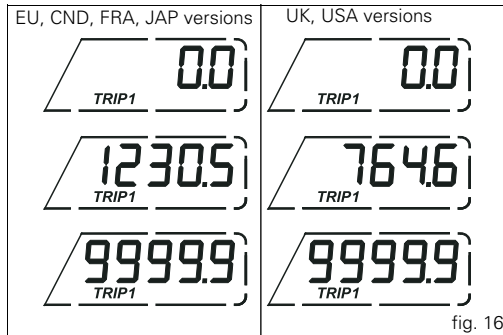



## Indication if the DTC function is active/not active

This function indicates if DTC (Ducati Traction Control) is active. When "DTC" is not lit up in the inside the rim, this means that the function is disabled.

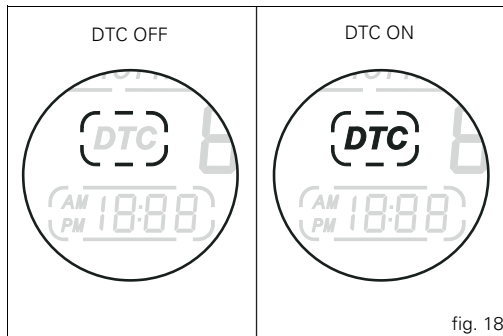

fig. 18

## Indication if the LAP function is active/not active

This function indicates if LAP (Lap number) is active. When "LAP" is not lit up, this means that the function has been switched off.

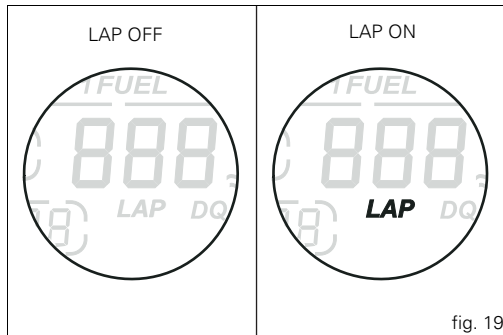

fig. 19

## Warning indication (Alarms/Signals)

The instrument panel shows some signals/malfunctions in real time on the circular “Dot-Matrix” display (B, fig. 20) that are not dangerous for correct vehicle operation.

At Key-On (at the end of the check) one or more “warnings” are displayed if they are active.

If a “warning” is activated during operation, the current indication on the circular “Dot-Matrix” display (B, fig. 20) will switch automatically to the indicator.

If there are multiple indicators, they will scroll automatically every 3 seconds.



### Note

No signal lights turn on if one or more “warnings” are activated.

The following “warnings” could be displayed:

- Battery level;
- Traction control;
- Hands free key;
- Hands free key battery level;
- Coolant temperature;
- Steering release error.

When one or more “warnings” are active, it is possible to go to other functions by pushing button (2, fig. 8) “▼”.

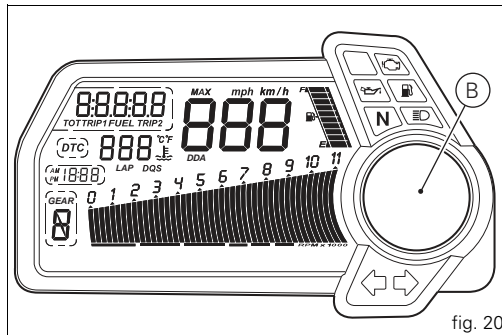

fig. 20

## “Low” battery level

The activation of this “warning” indicates that the status of the battery vehicle is low.

It is activated when the battery voltage is  $\leq 11.0$  Volt.



### Note

In this case, Ducati recommends charging the battery as soon as possible with the specific device, as it is possible that the vehicle will not start.

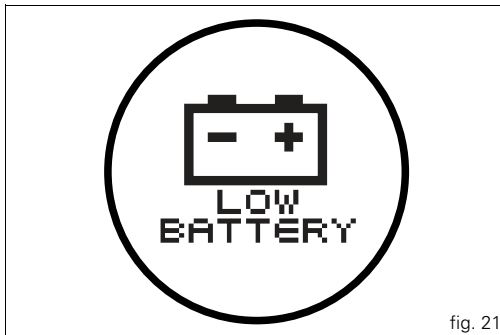

fig. 21

## Traction Control (DTC) deactivated

The activation of this “warning” indicates that DTC (Ducati Traction Control) has been turned off.



### Note

In this case, Ducati recommends being very careful when riding as the vehicle behaviour will be different in comparison to when operating with the Traction Control activated.

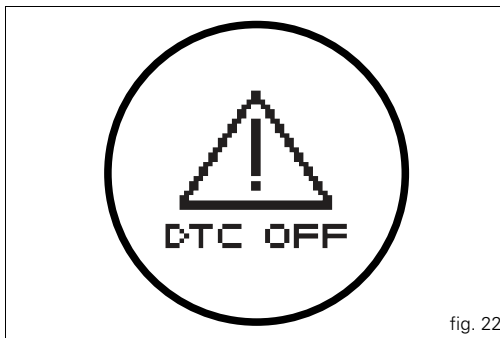

fig. 22

## Hands Free key (HF) not recognised

The activation of this “warning” indicates that the Hands Free system does not detect the active key (1, fig. 50) near the vehicle.



### Note

In this case, Ducati recommends checking that the active key (1, fig. 50) is near the vehicle (and has not been lost) and that it functions properly.



fig. 23

## “Low” Hands Free key (HF) battery level

The activation of this “warning” indicates that the Hands Free system has detected that the battery that permits the active key (1, fig. 50) to communicate and turn the vehicle on is almost discharged.



### Note

In this case, Ducati recommends replacing the battery as soon as possible as described in the paragraph “Replacing the active key battery” (page 74).



fig. 24

## E “High” engine coolant temperature

The activation of this “warning” indicates that the engine coolant temperature is high.  
It is activated when the temperature reaches 121°C (250°F).



### Note

In this case, Ducati recommends stopping and shutting off the engine immediately; make sure that the fans are working.



fig. 25

## Steering release error - Steering still locked

The activation of this “warning” indicates that the Hands Free System was not able to extract the steering lock.



### Warning

In this case, Ducati recommends turning the vehicle off and on (Key-Off / Key-On) holding the handlebar pressed down to the end stop. If the signal remains (and the steering does not “release”) contact a Ducati Dealer or Authorised Service Centre.

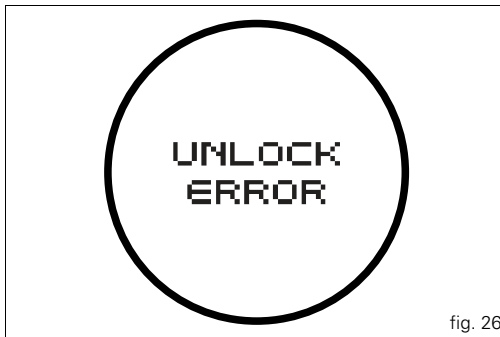

fig. 26

## Instrument panel diagnostics

This function identifies any abnormal vehicle behaviours.

The instrument panel activates any abnormal vehicle behaviours in real time (ERRORS).

At Key-On (at the end of the check) one or more "ERRORS" are displayed (only if they are active).

If an "error" is activated during operation, the current indication on the circular "Dot-Matrix" display (B, fig. 7) will switch automatically to the indicator.







If there are multiple errors, they will scroll automatically every 3 seconds. The "Engine/vehicle diagnosis - EOBD" light (8, fig. 4) always turns on when one or more errors are activated.

When one or more errors are active, it is possible to go to other functions by pushing the button (2, fig. 8) "▼". Possible errors are listed in the table below.



### Warning

When one or more errors are displayed, always contact a Ducati Dealer or Authorised Service Centre.

WARNING LIGHT	ERROR MESSAGE	ERROR
	BBS/DTC	Black Box / Traction Control control unit
	GEAR SENSOR	Gear sensor
	FUEL SENSOR	Fuel Level Sensor
	SPEED SENSOR	Speed sensor
	EXVL ERROR	Exhaust valve starter motor
	UNKNOW DEVICE	Unknown control unit

WARNING  
LIGHT

## ERROR MESSAGE

## ERROR



DEVICE ECU

ECU control unit not functioning



DEVICE DASHBOARD

Instrument panel not functioning



DEVICE HANDS FREE

Hands Free control unit not functioning



DEVICE BBS - DTC

Black Box control unit not functioning



THROTTLE POSITION

Incorrect throttle position



ACCELER. POSITION

Incorrect accelerator position



ETV MOTOR

Throttle starter motor not functioning



ETV RELAY

Relay throttle motor not functioning



PRESSURE

Atmospheric pressure sensor



ENGINE TEMPERAT.

Engine temperature















AIR TEMP.

Air temperature



FUEL INJECTION

Injection relay

WARNING LIGHT	ERROR MESSAGE	ERROR
	COIL	Coil
	INJECTOR	Injector
	PICK-UP	Timing/rpm sensor
	LAMBDA	Lambda sensor
	LAMBDA HEATER	Lambda heater
	FAN RELAY	Fan relay
	HIGH BEAM	High beam headlight relay
	LOW BEAM	Low beam headlight relay
	CAN	CAN communication line
	BATTERY	Battery voltage (HIGH or LOW)
	STOP LIGHT	Rear stop light
	ECU GENERIC	ECU error



---

WARNING  
LIGHT

ERROR MESSAGE

ERROR

---



KEY ERROR

HF communication problem

---



HANDS FREE GENERIC

Hands Free ECU error

---

## Service indicator

This function indicates that the vehicle is about to or has travelled a distance for which an Authorised Ducati Service Centre should be contacted to have the general maintenance or oil change performed.

## Residual range indication when the SERVICE is due

When 1000 Km (621 miles) are left until reaching the mileage programmed by Ducati for having the "SERVICE" performed, the instrument panel activates (at the end of the initial check) the indication of which type of service should be performed and the residual range (count-down).

The indication is activated each time the motorcycle is turned on (Key-On) for 5 seconds (flashing).

The residual range is updated every 100 Km (-1000, -900, -800, -700, etc.....).



### Warning

This message can only be reset by the Ducati Dealer or Authorised Service Centre that performs the maintenance.

## Indication of range reached for SERVICE

If you reach the mileage programmed by Ducati, the instrument panel will activate (at the end of the initial check) the indication that you should go to a Ducati Dealer or Authorised Service Centre to have the scheduled maintenance "DESMO SERVICE" or "OIL SERVICE" performed.

The indication is activated each time the motorcycle is turned on (Key-On) (not flashing); pressing the button (2, fig. 8) "▼" the other functions can be displayed;

The indication will remain until it is reset and it can be displayed at any moment by scrolling the functions.



### Warning

This message can only be reset by the Ducati Dealer or Authorised Service Centre that performs the maintenance.



### Note

The distance travelled thresholds are defined in an "absolute" sense and do not account for when the "reset" request for the indication is made by the Authorised Ducati Service Centre.

# Maintenance table

Indicator	Mileage travelled	count down -1000 DESMO SERVICE	count down -1000 OIL SERVICE	DESMO SERVICE	OIL SERVICE
1	1000				•
2	11000		•		
	12000				•
3	23000	•			
	24000			•	
4	35000		•		
	36000				•
5	47000	•			
	48000			•	
6	59000		•		
	60000				•
7	71000	•			
	72000			•	
8	83000		•		
	84000				•
9	95000	•			
	96000			•	

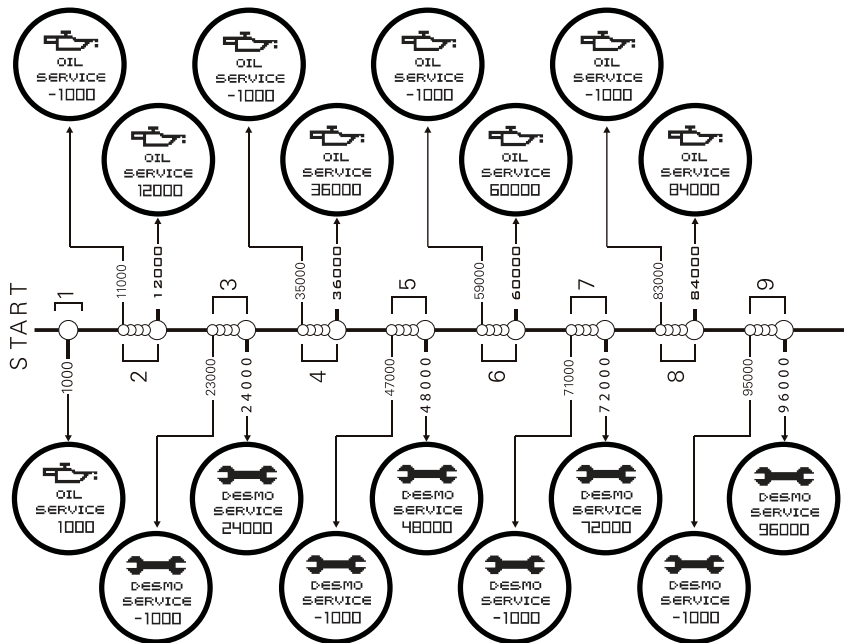
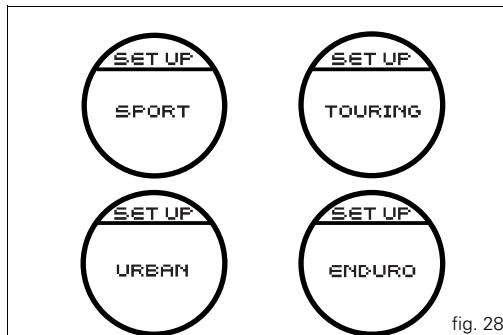

fig. 27

## SET UP - "Riding Mode set" indication

This function indicates the "Riding Mode" set for the vehicle. Four "Riding Modes" are available: SPORT, TOURING, URBAN and ENDURO.

Each riding mode can be changed using the "Riding Mode" function.



## “RANGE” indicator - remaining range

This function indicates the distance that can be travelled with the fuel currently in the tank.

The calculation is made based on the fuel level and an average consumption in reference to the last 90 seconds of driving (not the average fuel consumption “CONS M.”).

If you refuel adding more than 4 litres of fuel with the vehicle switched off (Key-Off), at the subsequent Key-On, the remaining range reading will be updated instantaneously and will be calculated based on the new fuel level and an average fuel consumption of 18.0 Km/L; otherwise (that is, if you add less than 4 litres) the reading will only be updated after the vehicle is in movement (not instantaneously).

When the range arrives to “0” the indication will flash together with the symbol (motorcycle + fuel pump).

The active calculation phase occurs when the engine is running and the vehicle is moving (moments when the vehicle is not moving when speed is equal to 0 and/or when the engine is off are not considered).

## Warning

It is recommended to turn off the motorcycle (Key-Off) when refuelling; if adding fuel without turning off the motorcycle (Key-On/engine off), the reading will be updated as soon as the vehicle starts to move (speed greater than zero).



## Warning

The residual range that is measured is an approximate value; Ducati recommends not trying to use all the residual range indicated.

E

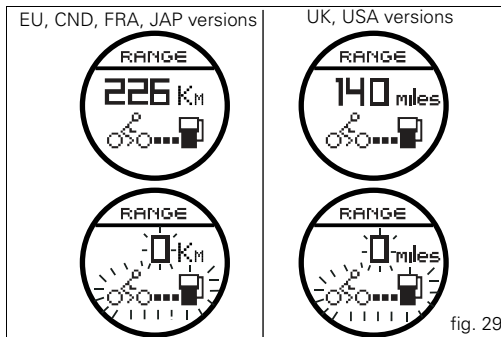

fig. 29

## Indicator "CONS I." - Instantaneous fuel consumption

This function indicates the "instantaneous" fuel consumption. The calculation is made considering the quantity of fuel used and the distance travelled during the last second. the datum is expressed in "l / 100" (litres / 100 Km); it is possible to set the unit of measurement "Km / l" (kilometres / litre) through the "Setting special" function.

The active calculation phase only occurs when the engine is running and the vehicle is moving (moments when the vehicle is not moving when speed is equal to 0 and/or when the engine is off are not considered). Dashes " - - ." are shown on the display when the calculation is not made.

## Indicator "CONS M." - Average fuel consumption

This function indicates the "average" fuel consumption. The calculation is made considering the quantity of fuel used and the km travelled since the last Trip 1 reset. When Trip 1 is reset, the value is set to zero and the first available value is shown on the display 10 seconds after the reset. Dashes " - - ." are shown on the display during the first 10 seconds when the value is not yet available.

the datum is expressed in "l / 100" (litres / 100 Km); it is possible to set the unit of measurement "Km / l" (kilometres / litre) through the "Setting special" function.

The active calculation phase occurs when the engine is running and the vehicle is stopped (moments when the vehicle is not moving and the engine is off are not considered).

EU, CND, FRA, JAP versions



UK, USA versions



fig. 30

EU, CND, FRA, JAP versions

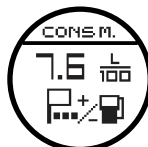

UK, USA versions



fig.31

## Indicator “AVG” - Average speed

This function shows the average speed of the motorcycle. The calculation is made considering the distance and time travelled since the last Trip 1 reset. When Trip 1 is reset, the value is set to zero and the first available value is shown on the display 10 seconds after the reset. Dashes “-.-” are shown on the display during the first 10 seconds when the value is not yet available.

The active calculation phase occurs when the engine is running and the vehicle is stopped (moments when the vehicle is not moving and the engine is off are not considered).

The calculated value is displayed increased by 8% to align it with the vehicle indicated speed.

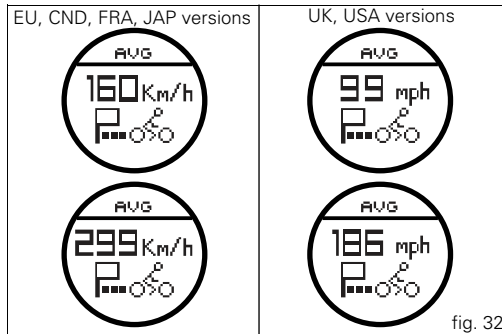

## Air temperature indicator

This function shows the external temperature.

Display limits:  $-39^{\circ}\text{C} \div +124^{\circ}\text{C}$

In the event of a sensor FAULT ( $-40^{\circ}\text{C}$ ,  $+125^{\circ}\text{C}$  or disconnected), a string of dashes “-.-” (not flashing) is displayed and the “Engine/Vehicle Diagnosis - EOBD” light (8, fig. 4) comes on and an error is indicated inside “Errors” Menu.



### Note

When the vehicle is stopped, the engine heat could influence the displayed temperature.

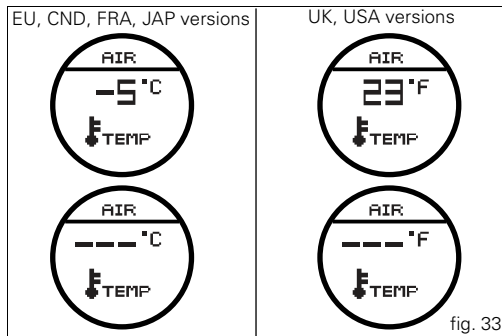



E When the detected temperature drops to 4°C (39°F), the display warns that the formation of ice is possible. The indication turns off when the temperature rises to 6°C (43°F).



### Warning

This warning does not exclude the possibility of icy road sections even at temperatures above 4°C (39°F); when external temperatures are “low” it is always recommended to ride carefully, particularly on sections that are not exposed to the sun and/or on bridges.

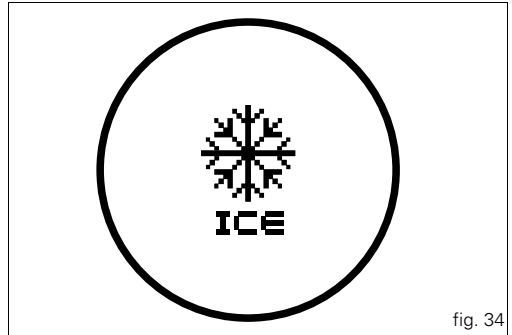

fig. 34

## Indicator "TIME TRIP" - Trip time

This function shows the vehicle trip time.

The calculation is made considering the time travelled since the last Trip 1 reset. When Trip 1 is reset, the value is set to zero.

The active phase calculation occurs when the engine is running and the vehicle is stopped (when the vehicle is not moving and the engine is off the time is automatically stopped and restarts when the counting active phase starts again).

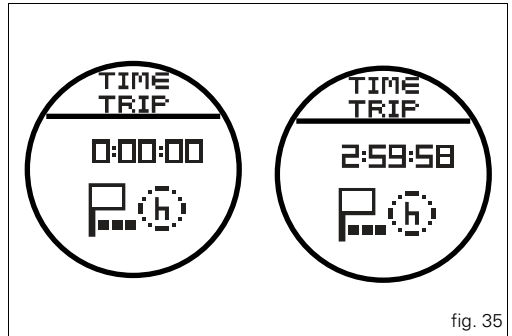

## E “Riding Mode” function (riding mode change)

This function changes the motorcycle riding mode. Each riding mode is associated with a different intervention level of the traction control (DTC - Ducati Traction Control) and different engine power and output.

To change the motorcycle riding mode, press the reset button once (13, fig. 5) and the “SET UP” menu will appear on the circular display (B, fig. 7).

The desired riding mode can be selected by pressing the same reset button multiple times (13, fig. 5). Press the same button for 3 seconds to confirm the riding mode.

If the throttle grip is closed (vehicle stopped) the riding mode change will occur immediately; if the throttle grip is open (vehicle moving) the message “CLOSE THROTTLE TO ACTIVATE” will appear on the display, which means that the throttle must be closed; this message will appear for 5 seconds, during which the gas must be closed in order to activate the new riding mode.

If the throttle grip is not closed after 5 seconds, the procedure is aborted (no change is made).

If the “SET UP” menu is activated and the reset button is not pressed (13, fig. 5) for 10 consecutive seconds, the instrument panel will automatically exit the display mode without making any change.



### Warning

Ducati recommends changing the riding mode when the vehicle is stopped. If the riding mode is changed while riding, be very careful (it is recommended to change the riding mode at a low speed).

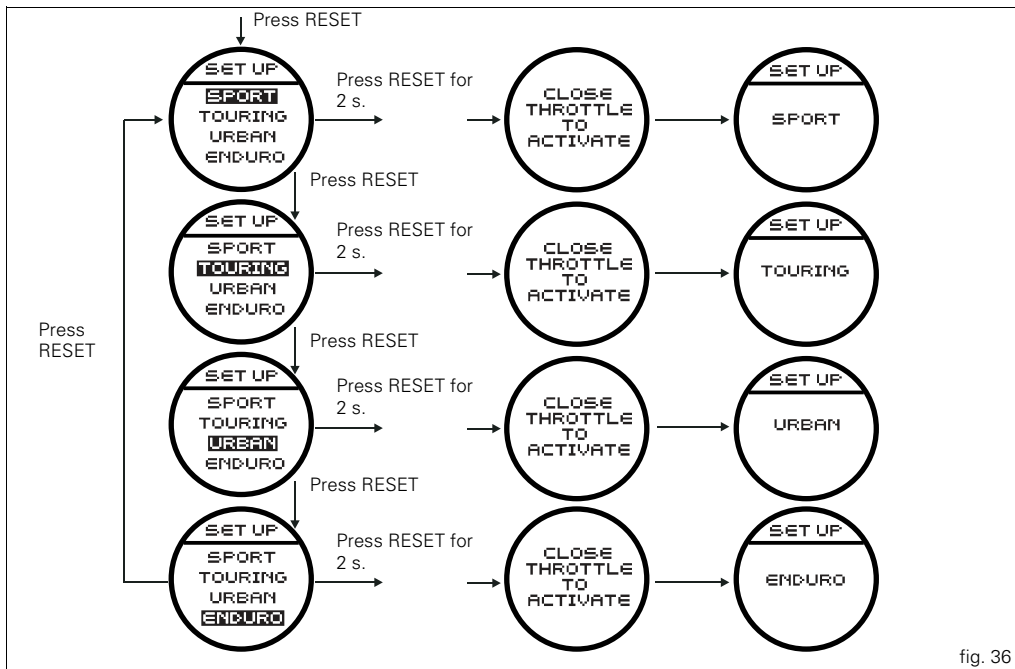

fig. 36

## E “Setting” menu

This menu is used to set/enable some motorcycle functions. To access the “setting menu” press the button (2, fig. 8) “▼” for 2 seconds.



### Note

Once this menu has been accessed, it is not possible to scroll the functions on the main display (A, fig. 7).



### Important

For safety reasons, the setting menu can only be accessed when motorcycle speed is lower than or equal to 20 Km/h. If this menu is open and the speed of the motorcycle exceeds 20 km/h, the instrument panel automatically exits the menu and returns to the “main” display.

The setting menu contains the following “items”:

- EXIT
- BATTERY
- SETUP
- B.LIGHT
- LAP
- DTC
- RPM
- CLOCK
- PIN CODE
- EXIT

To exit the setting menu, use button (1, fig. 8) “▲” or button (2, fig. 8) “▼” to select “EXIT” (present at the beginning and the end of the menu item list) and press the reset button (14, fig. 5).



## Battery voltage indicator (BATTERY)

This function describes the battery voltage indicator.

To display the function, enter the "Setting" menu page 44 and access the "BATTERY" page.

The information will be displayed as follows:

- if battery voltage is between 11.8 and 14.9 Volt the reading will be displayed steady;
- if battery voltage is between 11.0 and 11.7 Volt the reading will be displayed flashing;
- if battery voltage is between 15.0 and 16.0 Volt the reading will be displayed flashing;
- if battery voltage is equal to or less than 10.9 Volt, "LOW" is shown flashing and the "Vehicle/Engine Diagnosis - EOBD" light (8, fig. 4) comes on;
- if battery voltage is equal to or greater than 16.1 Volt, "HIGH" is shown flashing and the " Vehicle/Engine Diagnosis - EOBD" light (8, fig. 4) comes on;



### Note

Dashes "---" appear if the reading is not available.

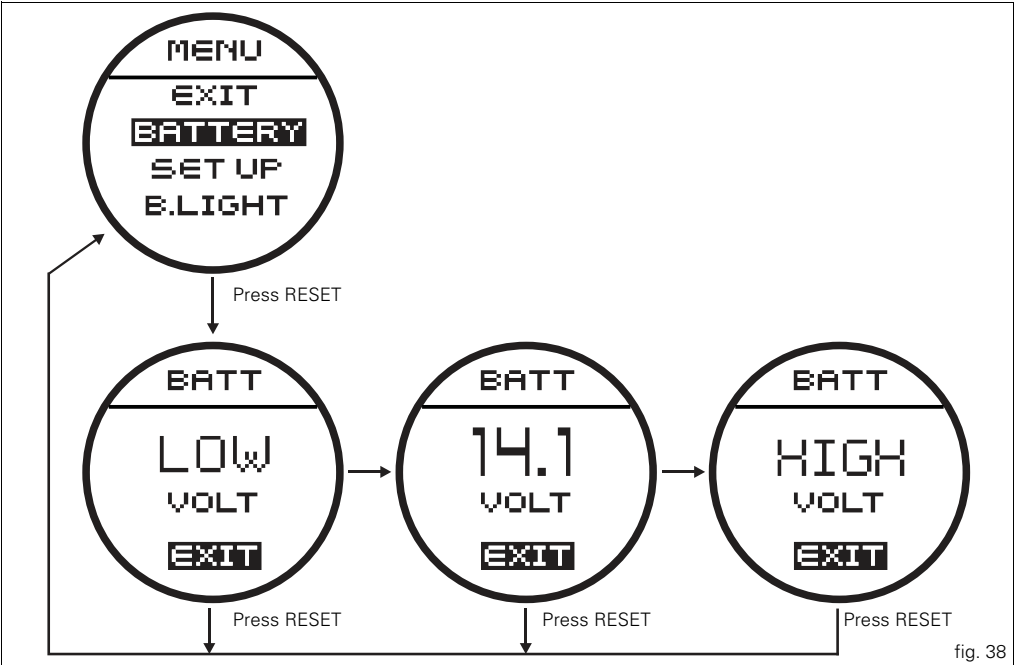

fig. 38



## E “Riding Mode” customisation

This function customises each riding mode.

To display the function, enter the “Setting” menu page 44 and access the “SET UP” page.

When accessing the function, the four riding modes appear on the circular display (B, fig. 7); to customise the parameters, use buttons (1, fig. 8) “▲” and (2, fig. 8) “▼” to select the riding mode to be changed and press the reset button (13, fig. 5) to confirm.

The parameters that can be “customised” are “DTC” (Ducati Traction Control) and “ENGINE”.

Any parameter change made is saved in the memory also after a Battery-Off.

To change the DTC parameters see the “DTC (Ducati Traction Control)” paragraph page 50.

To change the Engine parameters see the “ENGINE (engine power control)” paragraph page 54.

The parameters set by Ducati for each individual riding style can be restored with the “DEFAULT” function.

To reset the “default” parameters see the “DEFAULT (Resetting Ducati default parameters)” paragraph page 56.



### Warning

Changes should only be made to the parameters by people who are experts in motorcycle setup; if the parameters are changed accidentally, use the “DEFAULT” function to reset the parameters.

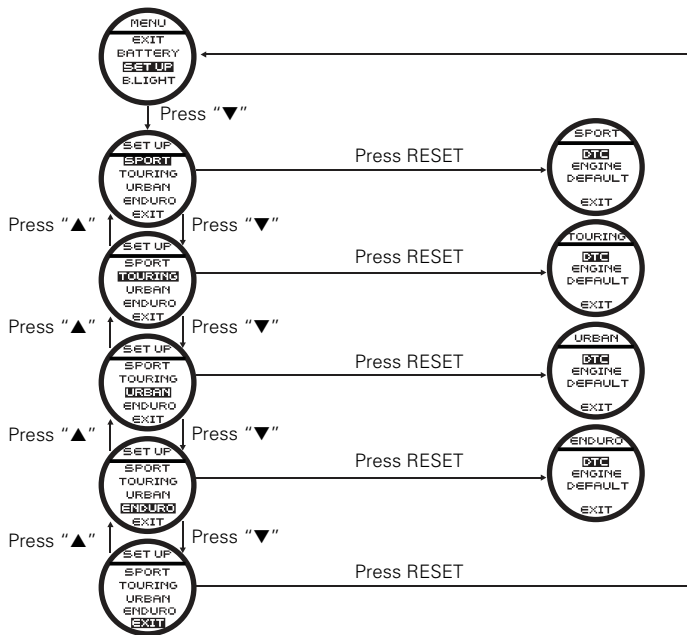

fig. 39

## E DTC (Ducati Traction Control) setting function

This function customises the intervention level of the DTC (Ducati Traction Control).

To display the function, enter the "Setting" menu page 44 and access the "SET UP" page. Use buttons (1, fig. 8) "▲" and (2, fig. 8) "▼" to select the riding mode to be changed and press the reset button (13, fig. 5) to access the "DTC" function.

When accessing the function, the set DTC level "LEVEL N" will appear at the top of the circular display (B, fig. 7). The intervention levels range from "1" to "8"; the higher the number, the greater the intervention of the Traction Control system.

To change the DTC intervention level, use buttons (1, fig. 8) "▲" and (2, fig. 8) "▼" to select the "NEW LEVEL" indication and press the reset button (13, fig. 5).

The number to be set is shown on the display; buttons (1, fig. 8) "▲" and (2, fig. 8) "▼" can increase or decrease the number; press the reset button (13, fig. 5) to confirm the new level.

At this point, store the new setting by pressing the reset button (13, fig. 5) with "MEMORY" displayed.

The upper indication "LEVEL N.2" will be updated to confirm that the new setting was "received" and stored.

To exit the function, select "EXIT" and press the reset button (13, fig. 5).

The DTC intervention increases, passing from level 1 to level 8.

The following table indicates the most suitable level of DTC intervention for the various riding types as well as the default settings in the "Riding Modes" that can be selected by the rider:

DTC LEVEL	RIDING TYPE	USE	DEFAULT?
1	ENDURO Professional	Off-road for very expert riders. It permits elevated rear wheel spin. It does not intervene in time on asphalt.	NO
2	ENDURO	Off-road for less experienced riders. Does not intervene in time on asphalt.	It is the default level for the "ENDURO" Riding Mode
3	TRACK	Track for very expert riders. Permits sliding sideways	NO
4	SPORT	Sporty driving on a road or track	It is the default level for the "SPORT" Riding Mode
5	TOURING	Normal riding	It is the default level for the "TOURING" Riding Mode
6	URBAN	"Very safe" riding together with the use of an 100HP ENGINE (maximum power 100 HP)	It is the default level for the "URBAN" Riding Mode
7	RAIN	Wet road	NO
8	HEAVY RAIN	Wet road and slippery asphalt	NO

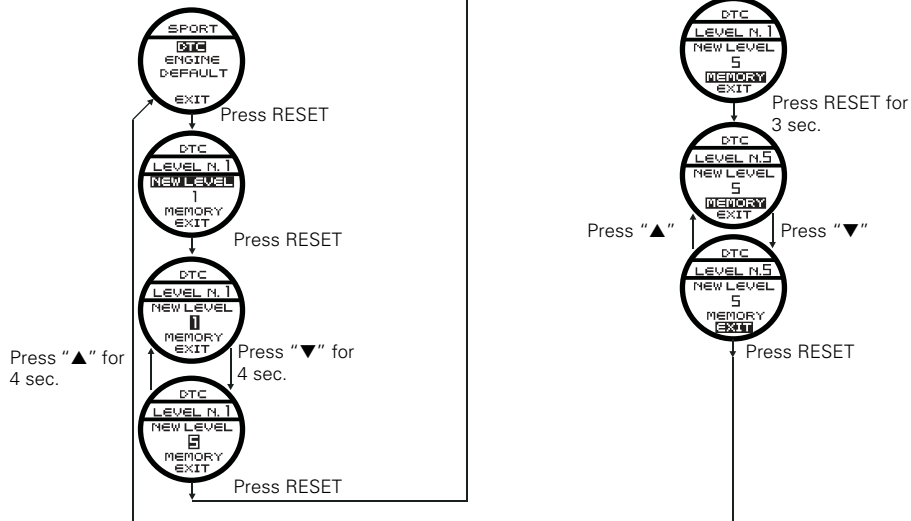

fig. 40

## Tips on how to select the sensitivity level



### Warning

The 8 DTC level settings have been calibrated using the same tyres as those originally supplied with your motorcycle (same make, model and size).

The use of tyres of different size to the original tyres may alter the operating characteristics of the system.

In the case of minor differences, such as for example, tyres of a different make and/or model than the original, but with the same dimensions (rear = 190/55-17; front = 120/70-17), it may be sufficient to simply select the most suitable level setting from those available to restore optimal system operation.

If tyres of a different size class are used or if the tyre dimensions differ significantly from the original tyres, it may be that the system operation is affected to the point where none of the 8 available level settings will give satisfactory results.

In this case it is advisable to deactivate the traction control system.

If level 8 is selected, the DTC control unit will kick in at the slightest hint that the rear wheel is starting to spin.

Between level 8 and level 1 there are a further 6 intermediate levels. The level of DTC sensitivity decreases in equal steps from level 8 to level 1.

When level 1, 2 or 3 is selected the DTC control unit will allow the rear wheel to spin and also slide sideways on exiting a corner; we recommend that this setting is only used by very experienced riders on the track.

The choice of the correct level depends on 3 main variables:

- 1) The grip (type of tyre, amount of tyre wear, the road/ track surface, weather conditions, etc.)
- 2) The characteristics of the path/circuit (bends all taken at similar speeds or at very different speeds)
- 3) The riding style (whether the rider has a "smooth" or a "rough" style)

The relation of the DTC intervention level to grip conditions:  
The choice of level setting depends greatly on the grip conditions of the track/circuit (see below, tips for use on the track and on the road).

The relation of the DTC intervention level to the circuit characteristics:

If all the corners on the track/circuit can be taken at a similar speed, it will be easier to find an intervention level that is satisfactory for every bend; on the other hand, if the track has, for example, one corner that is much slower than all the others, it will necessary to find a compromise level (on the slow corner the DTC will tend to control more than on the faster corners).

The relation of the DTC intervention level to riding style:

The DTC will tend to kick in more with a "smooth" riding style, where the bike is leaned over further, rather than with a "rough" style, where the bike is straightened up as quickly as possible when exiting a turn.

## Tips for use on the track

We recommend that level 8 is used for a couple of full laps (to allow the tyres to warm up) in order to get used to the system. Then try levels 7 and 6, etc., in succession until you identify the DTC sensitivity level that suits you best (always try each level for at least two laps to allow the tyres to warm up).

Once you have found a satisfactory setting for all the corners except one or two slow ones, where the system tends to kick in and control too much, you can try to modify your riding style slightly to a more "rough" approach to cornering i.e. straighten up more rapidly on exiting the corner, instead of immediately trying a different level setting.

## Tips for use on the road

Activate the DTC, select level 8 and ride the motorcycle in your usual style; if the level of DTC sensitivity seems excessive, try reducing the setting to level 7, 6, etc., until you find the level that suits you best.

If changes in the grip conditions and/or circuit characteristics and/or your riding mode, and the level setting is no longer suitable, switch to the next level up or down and proceed as described above to determine the best setting (e.g. if with level 7 the DTC intervention seems excessive, switch to level 6; alternatively, if on level 7 you cannot perceive any DTC intervention, switch to level 8).

## E ENGINE setting function (Engine Power Control)

This function customises engine power and output.

To display the function, enter the "Setting" menu page 44 and access the "SET UP" page. Use buttons (1, fig. 8) "▲" and (2, fig. 8) "▼" to select the riding mode to be changed and press the reset button (13, fig. 5) to access the "ENGINE" function.

When accessing the function, the engine setting (150 HIGH, 150 LOW or 100 HP) appears at the top of the circular display (B, fig. 7).



### Note

In Japan and France versions, the circular display (B, fig. 7) displays the settings (HIGH, MID and LOW).

To change the engine "power", use buttons (1, fig. 8) "▲" and (2, fig. 8) "▼" to select the "NEW SET" indication and press the reset button (13, fig. 5).

Use buttons (1, fig. 8) "▲" and (2, fig. 8) "▼" to select one of the three options (150 HIGH, 150 LOW or 100 HP) or (HIGH, MID e LOW) for France and Japan versions; press the reset button (13, fig. 5) to confirm the new level.

At this point, store the new setting by pressing the reset button (13, fig. 5) for 3 seconds with "MEMORY" displayed. The upper indication will be updated to confirm that the new setting was "received" and stored.

To exit the function, select "EXIT" and press the reset button (13, fig. 5).





## E DEFAULT function (Resetting Ducati default parameters)

This function resets the parameters set by Ducati for each riding mode.

To display the function, enter the "setting" menu page 44 and access the "SET UP" page. Use the buttons (1, fig. 8) "▲" and (2, fig. 8) "▼" to select the riding mode for which you want to restore the settings and access the "DEFAULT" function.

When accessing the function "DEFAULT PARAMETER?" will appear on the circular display (B, fig. 7); To reset the parameters, select "YES" and press the reset button (13, fig. 5).

For the parameter reset, approx. 15 seconds are needed during which "WAIT..." will appear on the display; at the end of the procedure, "DEFAULT OK" will appear on the circular display (B, fig. 7) to indicate that the parameters were reset.



### Important

This procedure restores the parameters for all riding modes.

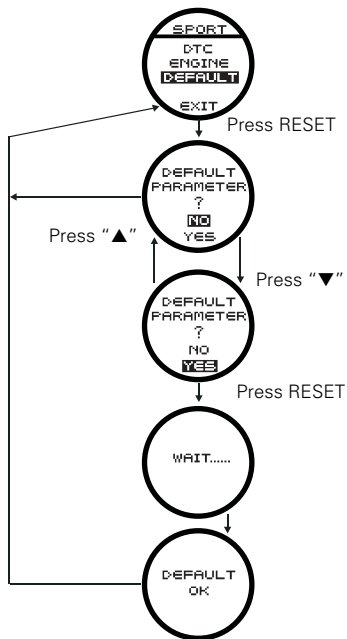

fig. 42

## Instrument panel backlighting adjustment function

This function adjusts the instrument panel backlighting intensity.

To display the function, enter the "setting" menu page 44 and access the "B. LIGHT" page.

The information will be displayed as follows:

- the arrows indicate the adjustment currently in use;
- use buttons (1, fig. 8) "▲" and (2, fig. 8) "▼" to select the new adjustment;
- to store the new adjustment press the reset button (13, fig. 5); the arrows will move to the new stored condition.

To exit, select "EXIT" and press the reset button (13, fig. 5).

"MAX" adjustment: storing this condition, the backlighting is at maximum brightness;

"MID" adjustment: storing this condition, the backlighting is reduced approximately 30% relative to maximum brightness;

"MIN" adjustment: storing this condition, the backlighting is reduced approximately 70% relative to maximum brightness;



### Note

In the event of an interruption of the power supply from the battery, when power is restored at the next Key-On, the backlighting will always be set by default to maximum brightness.



## E LAP Activation/Deactivation function (lap time)

This function activates and deactivates the LAP function (lap time).

To display the function, enter the "setting" menu page 44 and access the "LAP" page.

In the next display, press the reset button (13, fig. 5) showing "ON / OFF".

The information will be displayed as follows:

- the arrows indicate the setting currently in use;
- use buttons (1, fig. 8) "▲" and (2, fig. 8) "▼" to select the new setting;
- to store the new setting press the reset button (13, fig. 5); the arrows will move to the new stored condition.

To exit, select "EXIT" and press the reset button (13, fig. 5).

Storing the "OFF" condition disables the LAP function;

Storing the "ON" condition enables the LAP function (see LAP registration operation)



### Note

When the "LAP" function is active, the flash button (12, fig. 5) takes on the dual function of high beam headlight "flash" and lap time Start / Stop.

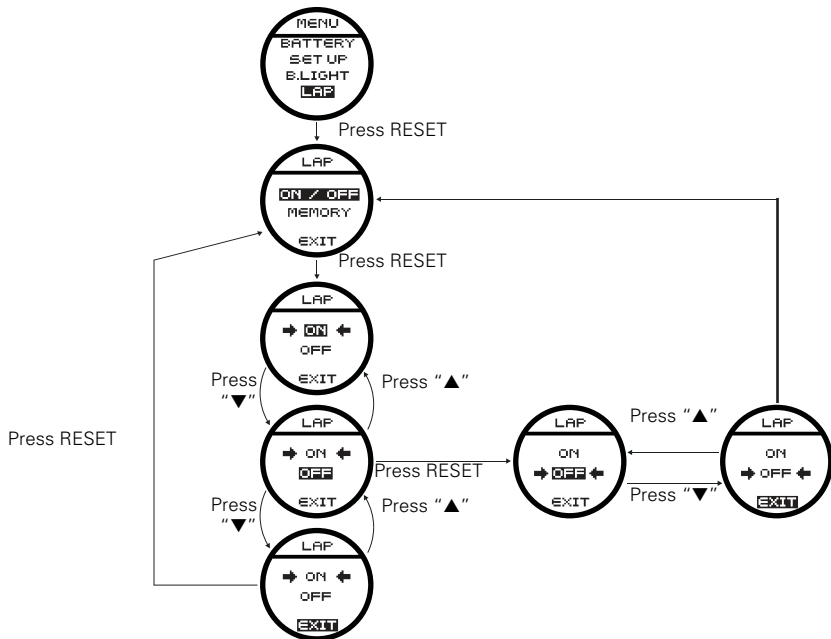

fig. 44

## LAP registration function

This function describes the "LAP" time registration.

If the function is activated (see "LAP activation/deactivation description), the lap time can be registered as follows:

- the first time the flash is pressed (12, fig. 5) starts the "lap timer" for the first lap and the instrument panel shows the "START LAP" indication on the circular display (B, fig. 7) for 4 seconds and then returns to the "previous" display;
- from this moment, each time that the flash is pressed (12, fig. 5) the circular display (B, fig. 7) automatically shows the lap time for 10 seconds and then returns to the "previous" display.

You can save a maximum of 30 laps in the memory.

If the memory is full, each time you press the flash button (12, fig. 5), the instrument panel will not store any more lap times and will show the flashing message "LAP MEMORY FULL" on the circular display (B, fig. 7) for 3 seconds until the times are reset.

When the LAP function is set disabled, the current "lap" is not stored.

If the LAP function is active and suddenly the motorcycle is suddenly turned off (Key-Off), the function will be automatically disabled (even if the lap timer was active, the current "lap" is not stored).

If the time is never "stopped", it will roll over upon reaching 9 minutes, 59 seconds and 99 hundredths; the lap timer starts counting from 0 (zero) and will keep running until the function is disabled.

If however the LAP function is switched on and the memory has not been cleared, but fewer than 30 laps have been saved (e.g. 18 laps), the instrument panel will store any remaining laps until the memory is full (in this case, it will store an additional 12 laps).

This function only displays the times for the lap being registered; but other data are also saved (MAX speed, MAX rpm, rev limiter if reached) for viewing at a later date in the Lap Memory function (stored LAP display).

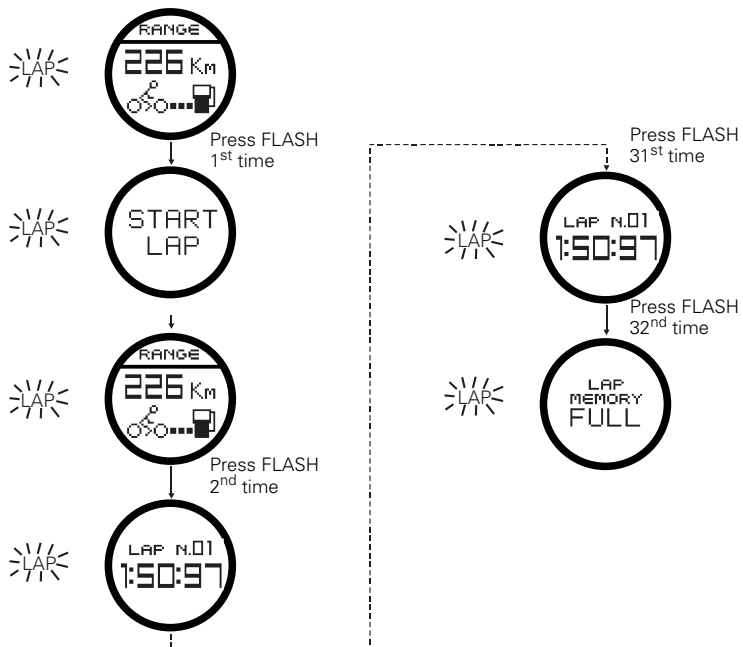

fig. 45



## Stored LAP display function

This function displays the stored LAPs.

To display the function, enter the "setting" menu page 44 and access the "LAP" page.

In the next display, press the reset button (13, fig. 5) showing "MEMORY".

The instrument panel displays the information as follows:

Circular display (B, fig. 7):

- the number of the displayed lap (ex: no.1);
- "NEXT" to display the next LAP;
- "RESET" to delete all the stored times;

To exit, select "EXIT" and press the reset button (13, fig. 5).

Main display (A, fig. 7):

- the time in the upper left (ex: 1:50:97);
- the maximum speed reached in the registered LAP to the upper right;
- the number of maximum RPMs reached in the registered lap at the bottom;



### Note

The MAX stored speed is indicated on the main display (A) (increased by 8%).

If the MAX speed reading exceeds 299 Km/h (186 mph) while the information is stored, the speed that was reached is still displayed (example: 316 Km/h).

If there is no reading in the memory, the 30 times are shown, with the display showing "0.00.00", MAX rpm = 0 and MAX speed = 0.

If while registering the LAP the engine reaches the threshold that precedes the rev limiter or rev limiter threshold, the relative light "Over Rev" (9, fig. 4) will turn on when displaying the stored times.

To display other stored times, select "NEXT" and press the reset button (13, fig. 5); the next lap will be displayed each time the reset button (13, fig. 5) is pressed.

To delete all the stored times, select "RESET" and press the reset button (13, fig. 5) for 3 seconds.



### Note

If the stored times are deleted while the LAP function is active, it will be automatically deactivated.

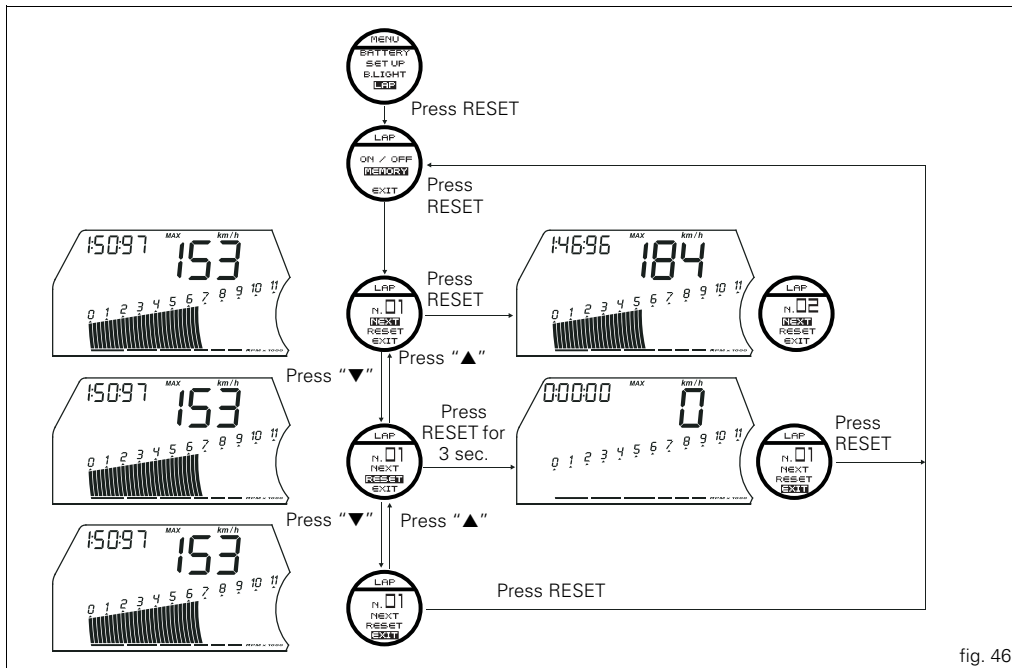

fig. 46

## E DTC (Ducati Traction Control) on/off function



### Warning

DTC is a rider aid that can be used both on the track and the road.

The system is designed to make riding easier and to enhance safety, but in no way relieves the rider of the obligation to drive responsibly and to maintain a high standard of riding in order to avoid accidents, whether caused by his own errors or those of other road users, through making emergency manoeuvres, in accordance with the prescriptions of the road traffic code.

The rider must always be aware that active safety systems have a preventive function. The active elements help the rider control the motorcycle, making it as easy and safe to ride as possible. The presence of an active safety system should not encourage the rider to ride at speeds beyond the reasonable limits, in accordance with the road conditions, the laws of physics, good riding standards and the requirements of the road traffic code.

This function activates and deactivates the DTC (Ducati Traction Control).

To display the function, enter the "setting" menu page 44 and access the "DTC" page.

In the next display, press the reset button (13, fig. 5) showing "ON / OFF".

The information will be displayed as follows:

- the arrows indicate the setting currently in use;
- use buttons (1, fig. 8) "▲" and (2, fig. 8) "▼" to select the new setting;
- to store the new setting press the reset button (13, fig. 5); the arrows will move to the new stored condition.

To exit, select "EXIT" and press the reset button (13, fig. 5). Storing the "OFF" condition disables the Traction Control; Storing the "ON" condition enables the Traction Control.



### Note

Deactivating the DTC automatically activates the previously described "warning" "DTC OFF". If a battery is cutoff, when the voltage is restored and at the next Key-On, the DTC will always be set automatically to "OFF".



## Digital RPM indication function

This function displays the number of RPMs for improved accuracy when setting idle rpm.

To display the function, enter the "setting" menu page 44 and access the "RPM" page.

The display shows the numerical value of the RPM with a precision of 50 rpm.

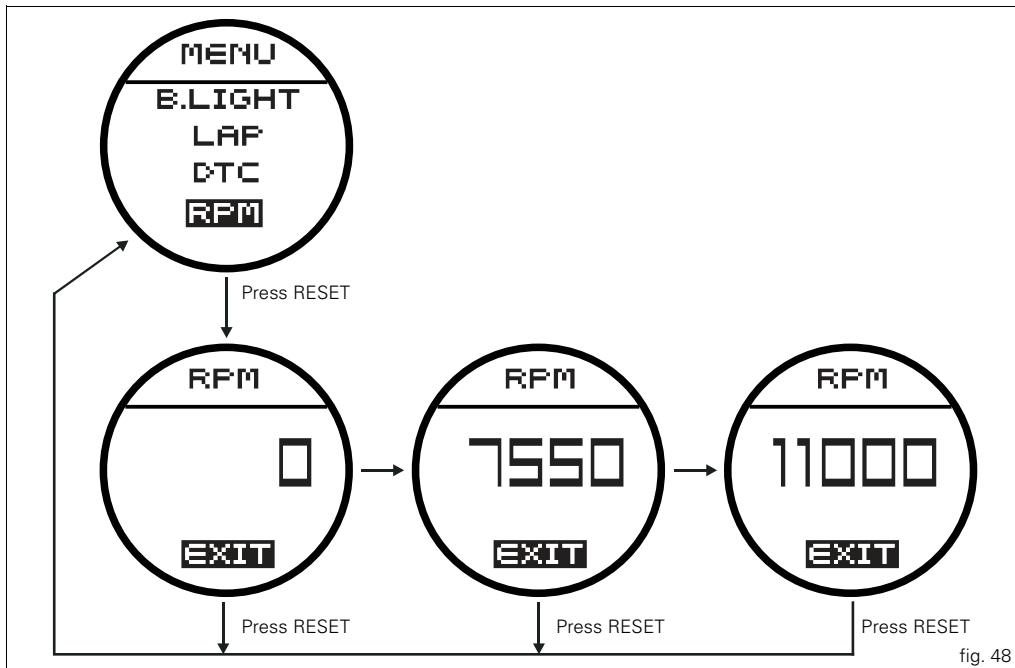

fig. 48

## Clock setting function

This function sets the clock.

To display the function, enter the "setting" menu page 44 and access the "CLOCK" page.

In the next display, press the reset button (13, fig. 5) showing "SET UP" for 3 seconds to proceed with the actual setting. "SET CLOCK ...." appears on the circular display (B) to indicate that the clock is being set; the time is set on the main display.

### Clock setting

On entering this function, the message "AM" flashes on the display;

if you press the button (2, fig. 8) "▼" "PM" flashes;

if you press the button (2, fig. 8) "▼" you will return to the previous step (if it is 00:00, when switching between "AM" to "PM", 12:00 will be displayed).

pressing button (1, fig. 8) "▲" accesses the hour setting mode; the hours start to flash.

each time you press the button (2, fig. 8) "▼", the digit will increase by 1 hour; if the button is held pressed down (2, fig. 8) "▼" the digit will increase by 1 hour every second (when the button is held depressed, the hours do not flash).

pressing button (1, fig. 8) "▲" gives access to the minute setting mode; minutes start to flash.

each time you press the button (2, fig. 8) "▼", the digit will increase by 1 minute; holding down the button (2, fig. 8) "▼", the digit will increase by 1 minute each second;

if the button is held depressed (2, fig. 8) "▼" for over 5 seconds, minutes will increase by 1 minute every 100 m

(while the button is held depressed (2, fig. 8) "▼", the seconds will not flash).

pressing button (1, fig. 8) "▲" the indication of the new time will flash and "MEM" will appear on the circular display.

To confirm (store) the new set time press the reset button (13, fig. 5).

To exit, select "EXIT" and press the reset button (13, fig. 5).



### Note

If a battery is cutoff, when the voltage is restored and at the next Key-On, the clock must be reset (it starts automatically from 00:00).

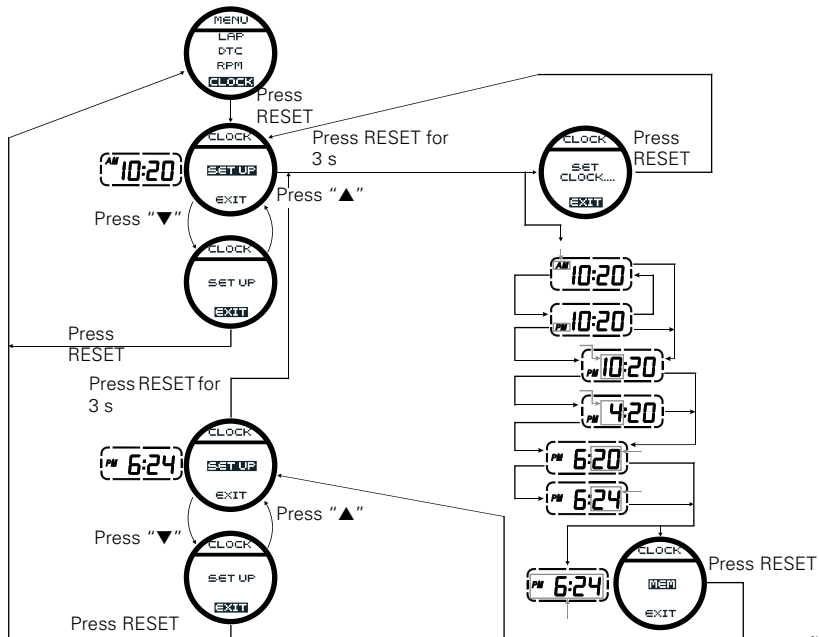

fig. 49



## The immobilizer system

For additional anti-theft protection, the motorcycle is equipped with an IMMOBILIZER, an electronic system that locks the engine automatically whenever the ignition switch is turned off.

The grip of each ignition key contains an electronic device that modulates the output signal from a special antenna in the top fairing when the ignition is switched On. The modulated signal acts as a password and tells the CPU that an "authorised" ignition key is being used to start up the engine. When the CPU recognises the signal, it enables engine start-up.

### Keys (fig. 50)

The owner receives a set of keys, comprising:

- 1 active key (1, fig. 50)
- 1 passive key (2, fig. 50)

It contains the code used by the "Hands free" system for the Key-On, in different modes.

The active key (1, fig. 51) is the one that is normally used and has a button (A, fig. 51) that when pressed makes the metal part exit (B, fig. 51). The metal part returns inside the grip by pushing it in.

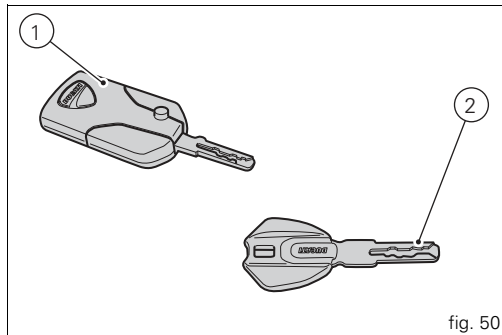

fig. 50

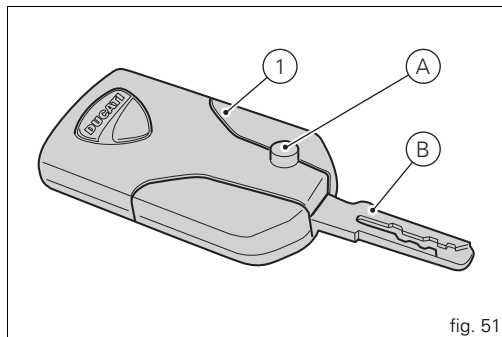

fig. 51

The key contains a battery that must be replaced when the message "low level" is displayed under the key and battery symbols when the instrument panel is turned on (fig. 52).



### Note

In this case, replace the battery as soon as possible (page 74).

When the charge level goes below a certain limit, the key can only work in passive mode, like the passive key: in this case, the instrument panel will not display any message.



### Warning

Do not ride with the key (1 or 2, fig. 50) inserted in the lock of the tank cap or in the seat lock as it could come out and represent a potential danger. Furthermore, if bumped, the key mechanism and the integrated circuit could be damaged.

Also riding in poor weather conditions with the key inserted could cause damage to its integrated circuit.

Do not leave the key on the motorcycle when washing it as it could be damaged, not being watertight.



fig. 52

## Replacing the battery in the active key

Only use 3 Volt CR 2032 lithium ion batteries.



### Note

The keys do not need to be reprogrammed after replacing the battery.

Remove the metal part of the battery.

Use a large sized coin to pry open the shells of the plastic grip (2€ coin) as shown in fig. 53.



### Important

Insert the coil only in the indicated point. Do not use other objects inserted in points that are different than what is shown, as it could damage the integrated circuit and/or the protective gasket.

Once the plastic shells have been separated, remove the printed circuit board (1, fig. 54) prying it up GENTLY with a small flat screwdriver, as shown in the figure.



### Important

Insert the point of the flat screwdriver just under the printed circuit board, being very careful not to damage it. Do not apply force on the battery or battery holder.

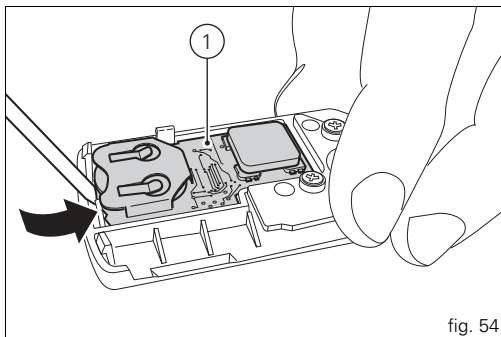
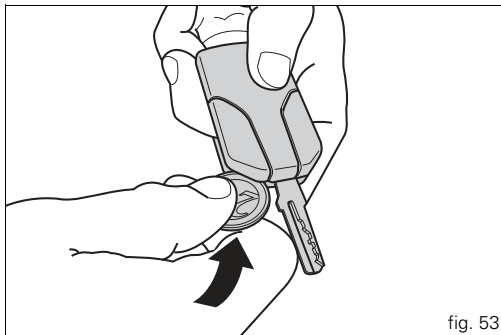

Remove the battery (2, fig. 55) from the printed circuit board (1, fig. 55) and replace it with a new one. Pay attention to polarity: the positive pole (+) must face upward.

**Important**  
Only use the required type of battery.

Reinsert the printed circuit board (1, fig. 56) from the side with the battery (2, fig. 56) into the plastic shell.

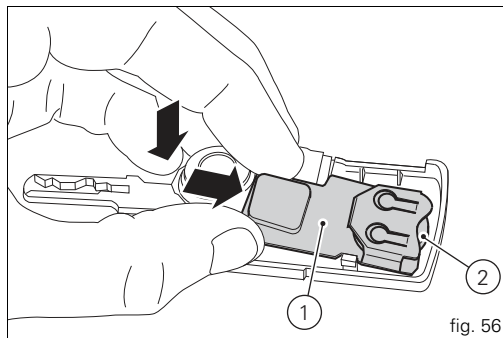
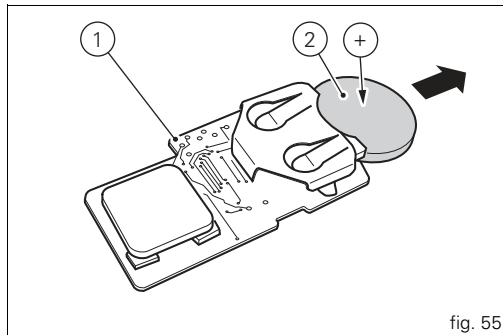

**E** Apply slight pressure on the antenna (3, fig. 57) of the printed circuit board until you hear a click.

Align the two shells of the grip and press on the area indicated by the arrows (fig. 58) to reclose them. Make sure that you hear a “click” upon closing and that the key is well closed.

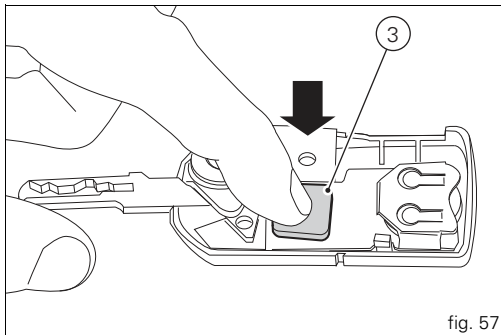

fig. 57

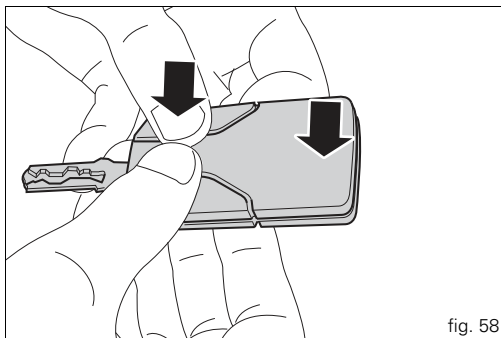

fig. 58

## Duplicate keys

If you need any duplicate keys, contact the Ducati Service network with all the keys you have left.

The Ducati Service Centre will program all the new keys as well as any keys you already have.

You may be asked to provide proof that you are the legitimate owner of the motorcycle.

The codes of any keys not submitted will be wiped off from the memory to make those keys unserviceable in case they have been lost.

## Immobilizer override procedure

This procedure makes it possible to “temporarily” turn on the motorcycle if the HF (Hands Free) System is not working.



### Note

The PIN CODE function must be activated by entering your 4 digit PIN in the instrument panel, otherwise the vehicle cannot be turned on temporarily in the case of a malfunction.



### Warning

The motorcycle owner must activate (store) the PIN code; if there is already a stored PIN, contact an Authorised Ducati dealer to have the function “reset”. To perform this procedure, the Authorised Ducati Dealer may ask you to demonstrate that you are the owner of the motorcycle.

## PIN CODE activation function

To display the function, enter the “setting” menu page 44 and access the “PIN CODE” page.



### Note

If “MODIFY” appears when accessing this function, this means that there is already a stored PIN and therefore the function is already active.

When accessing the function, “NEW PIN” four dashes “- - - -” will appear on the circular display (B, fig. 7); now enter a 4 digit code.

Entering the code:

each time you press the button (2, fig. 8) “▼” the displayed number increases from “0” to “9” and then returns to “0”; to confirm the number, press the reset button (13, fig. 5). Repeat the procedure until inserting the fourth digit. Press the reset button (13, fig. 5) again to confirm.

“OK” and “EXIT” will appear on the display.

To confirm the PIN that was entered, press the reset button (13, fig. 5) again showing “OK”.

“NEW PIN MEM” will appear on the display for 3 seconds to confirm that the PIN was stored.

At the end of the 3 seconds, the instrument panel exits automatically from the display and returns to the “setting” menu.

From this moment, “MODIFY” will be displayed when accessing the “PIN CODE” function and the PIN can be changed again.





## PIN CODE change function

This function changes your four number PIN CODE. To display the function, enter the “setting” menu page 44 and access the “PIN CODE” page.



### Note

If “NEW PIN” and the dashes “----” appear when accessing this function, this means that the function was not active as the PIN CODE was never entered. Enter your PIN as described in the previous paragraph “PIN CODE activation function”.

When accessing the function, “MODIFY” will appear on the circular display (B, fig. 7); press the reset button (13, fig. 5) showing “MODIFY” to modify the PIN.



### Note

To change the PIN, you must know the currently stored PIN.

“OLD PIN” and four dashes “----” will appear on the circular display (B, fig. 7); enter the old 4 digit code that was stored previously.

Entering the “old” PIN: each time you press the button (2, fig. 8) “▼” the displayed number increases from “0” to “9” and then returns to “0”;

To confirm the number, press the reset button (13, fig. 5); repeat the procedure until inserting the fourth digit; Press the reset button (13, fig. 5) again to confirm.

“OK” and “EXIT” will appear on the display.

To confirm the “old” PIN that was entered, press the reset button (13, fig. 5) again showing “OK”.

If the code is not correct, “OLD PIN WRONG” will appear for 3 seconds and then the instrument panel will return displaying “MODIFY” so you can repeat the attempt of entering the “old” code.

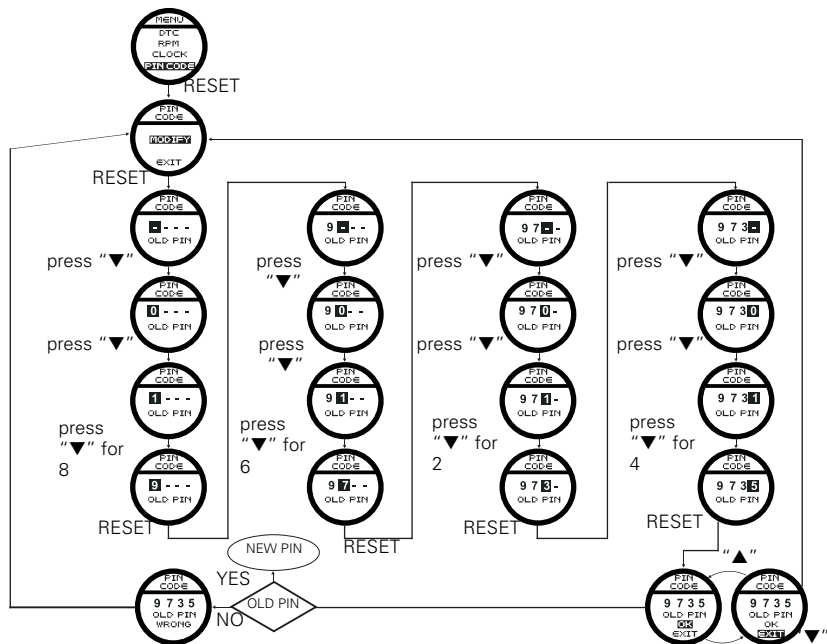

fig. 60

If the code was entered correctly the message "NEW PIN" and four dashes "- - - -" will appear on the circular display; now enter the "new" 4 digit code.

Entering the "new" PIN: each time you press the button (2, fig. 8) "▼" the displayed number increases from "0" to "9" and then returns to "0";

to confirm the number, press the reset button (13, fig. 5).

repeat the procedure until inserting the fourth digit;

Press the reset button (13, fig. 5) again to confirm.

"OK" and "EXIT" will appear on the display.

To confirm the PIN that was entered, press the reset button (13, fig. 5) again showing "OK".

"NEW PIN MEM" will appear on the display for 3 seconds to confirm that the PIN was stored.

At the end of the 3 seconds, the instrument panel exits automatically from the display and returns to the "setting" menu.

The PIN CODE modification procedure is complete.



### Note

There is no limit to the amount of times you can change your PIN CODE.

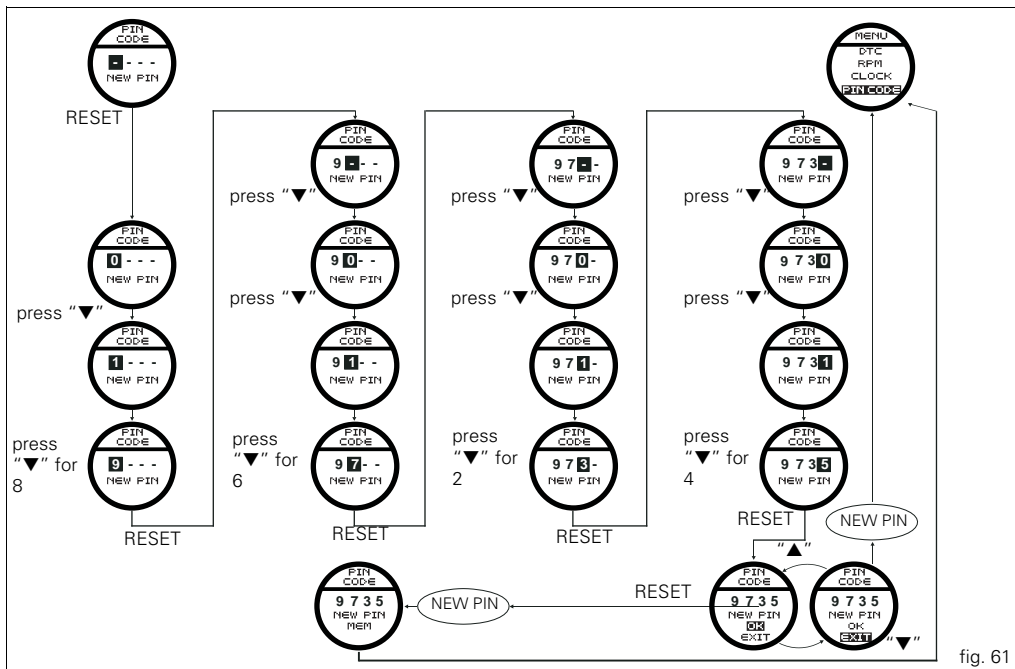

fig. 61

## Light control

### Headlight control

This function allows you to reduce current consumption from the battery, by automatically managing headlight switching-off.

At Key-On, the high beam and low beam lights are off.

When the engine is started, the low beam lights turn on automatically; from this moment on, lights “normal” operation is established: it is possible to switch between low beams and high beams (with button 12, fig. 5) or “FLASH” the lights (with button 12, fig. 5). If the engine is not started at Key-On, the lights can be turned on by pressing the button on the left high beam / low beam light switch (button 12, fig. 5); the low beam lights are turned on the first time it is pressed; from this moment, the same button can be used to switch between the low beam and high beam lights (if the engine is not started within 60 seconds, the low beam or high beam light that were turned on will turn off).

If the headlight was turned on before starting the engine with the procedure described above, the headlight turns off automatically when starting the vehicle and will turn on again when the engine has been completely started.

### Turn indicators (automatic reset)

The instrument panel controls the automatic reset of the turn indicators.

After activating one of the two turn indicators, they can be deactivated using the RESET button (13, fig. 5).

If the turn indicator is not “reset” manually, the instrument panel will automatically switch it off after the motorcycle has travelled 500 m (0.3 miles) from when the turn indicator was activated.

The counter for the distance travelled for automatic deactivation is activated at speeds below 80 Km/h (50 mph). If the calculation of the distance for automatic deactivation is activated and then the motorcycle exceeds a speed of 80 km/h (50 mph), the calculation is interrupted and will restart when the speed returns below the indicated threshold.

## “Parking” function

This function activates the “PARKING” mode.

The “PARKING” function activates the front and rear parking lights when the vehicle is turned off so it is visible when parked.

The function is activated by pressing the button (2, fig. 8) “▼” for 3 seconds during the first 60 seconds after the motorcycle was turned off.

Once the function is activated, the indication will remain on the circular display for 5 seconds and the lights will remain on for 2 hours. After 2 hours, then will turn off automatically.

To interrupt the function, turn the vehicle on and off.



### Note

If there is a sudden interruption in the battery while the function is active, the instrument panel will disable the function when the voltage is restored.



### Warning

The frequent use of this function can considerably reduce the battery charge; Ducati recommends using this function only when necessary.



fig. 62

## E “Steering in position for being locked” indication

This function informs that the steering is in position for turning on the steering lock.

The sensors detect that the steering is in position during the first 60 seconds after turning off the vehicle and the instrument panel activates the indication on the circular display for max. 5 seconds.

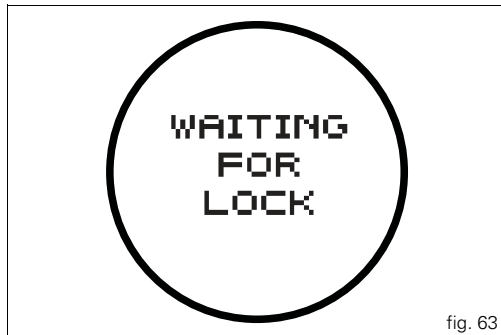

fig. 63

## “Steering lock” on indication

This function informs that the steering lock was turned on. The steering lock can be turned on during the first 60 seconds after turning off the vehicle by pressing down on the “RUN” button.

If the steering lock was turned on correctly, the instrument panel will show the indication in the circular display for 5 seconds.



### Note

The steering lock can only be turned on when the steering is in position.



fig. 64

## Indication of incorrect position of the red starter button

This message indicates to the user that the button should be returned to the “top” position in order to ensure that there is not an excessive current absorption by the system.



### Important

This could lead to battery discharge in a short time.

Any incorrect position is detected within the first 60 seconds after vehicle switch-off (Key-Off).

If you press the starter button (1, fig. 66) for over 1 second to switch off (Key-Off), system activates the warning “RED SWITCH NOT RELEASED” as a flashing message (fig. 65).

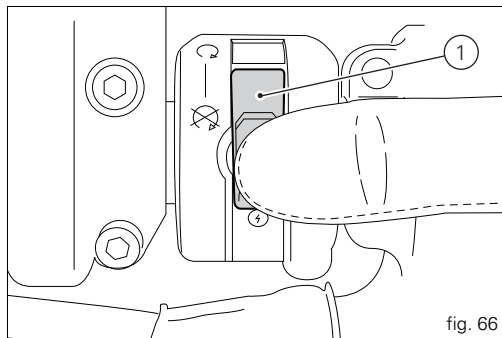
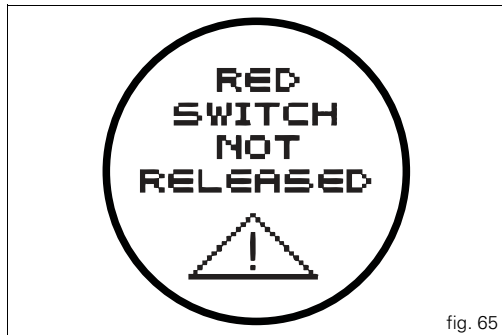



**E**

If the warning remains active once button (1, fig. 67) is no longer depressed, you shall take button (1, fig. 68) to "top" position.

In this case, report the fault to Dealer or Authorised Service Centre.

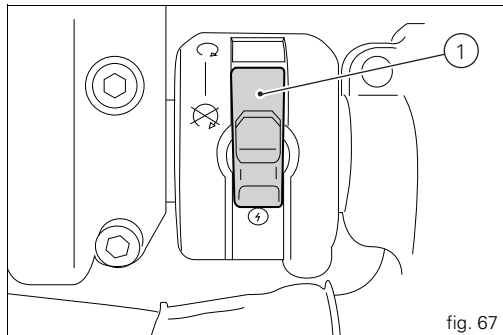

fig. 67

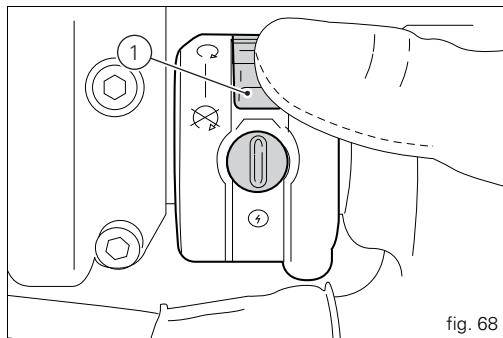

fig. 68

## Units of measurement modification

This function allows you to change the units of measurement of the displayed values.

In order to enter this menu it is necessary to start the vehicle by holding down contemporaneously both the flash button (12, fig. 5) and the reset button (13, fig. 5) for at least 3 seconds.

After entering this menu, "UNITS" is displayed; to set the units of measurements press the reset button (13, fig. 5).

The instrument panel displays the values that can be modified; use buttons (1, fig. 8) "▲" and (2, fig. 8) "▼" to select the value to modify and press the reset button (13, fig. 5) again.



### Note

In this MENU all other functions are disabled.

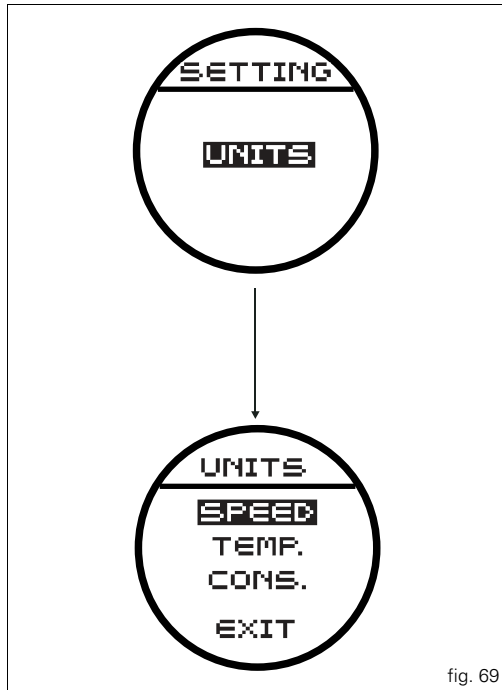

fig. 69

## “SPEED” setting

The arrows indicate the current setting, with buttons (1, fig. 8) “▲” and (2, fig. 8) “▼” it is possible to select the new setting.

To store the new setting it is necessary to press the reset button (13, fig. 5) for 3 seconds.

By storing the setting, the display is automatically quitted. Now it is necessary to turn off the vehicle (Key-Off); upon next Key-on any new unit of measurement will be set.

- 1) Km/h: by setting this condition the following values will have the same units of measurement:
  - TOT, TRIP1, TRIP2, RANGE: Km
  - Vehicle speed and AVG: Km/h
- 2) mph: by setting this condition the following values will have the same units of measurement:
  - TOT, TRIP1, TRIP2, RANGE: miles
  - Vehicle speed and AVG: mph

## “TEMP.” setting

The arrows indicate the current setting, with buttons (1, fig. 8) “▲” and (2, fig. 8) “▼” it is possible to select the new setting.

To store the new setting it is necessary to press the reset button (13, fig. 5) for 3 seconds.

By storing the setting, the display is automatically quitted. Now it is necessary to turn off the vehicle (Key-Off); upon next Key-on any new unit of measurement will be set.

- 3) °C: by setting this condition the following values will have the same units of measurement:
  - Engine coolant temperature and T\_AIR: °C

- 4) °F: by setting this condition the following values will have the same units of measurement:
  - Engine coolant temperature and T\_AIR: °F

## “CONS.” setting

The arrows indicate the current setting, with buttons (1, fig. 8) “▲” and (2, fig. 8) “▼” it is possible to select the new setting.

To store the new setting it is necessary to press the reset button (13, fig. 5) for 3 seconds.

By storing the setting, the display is automatically quitted. Now it is necessary to turn off the vehicle (Key-Off); upon next Key-on any new unit of measurement will be set.

- 5) Km/l: by setting this condition the following values will have the same units of measurement:
  - CONS I. and CONS M.: Km/l
- 6) l/100: by setting this condition the following values will have the same units of measurement:
  - CONS I. and CONS M.: l/100
- 7) UK mpg: by setting this condition the following values will have the same units of measurement:
  - CONS I. and CONS M.: UK mpg
- 8) USA mpg: by setting this condition the following values will have the same units of measurement:
  - CONS I. and CONS M.: USA mpg

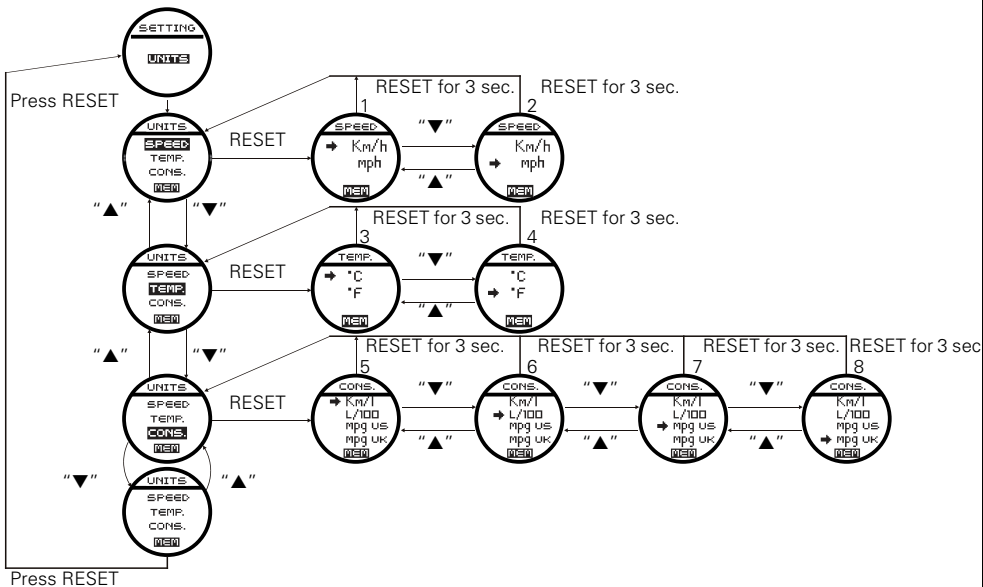

fig. 70

# Controls



## Warning

This section shows the position and function of the controls used to ride the motorcycle. Be sure to read this information carefully before you use the controls.

## Position of motorcycle controls (fig. 71)

- 1) Instrument panel.
- 2) "Hands free" system.
- 3) Left-hand handlebar switch.
- 4) Clutch lever.
- 5) Rear brake pedal.
- 6) Right-hand handlebar switch.
- 7) Throttle twistgrip.
- 8) Front brake lever.
- 9) Gear change pedal.

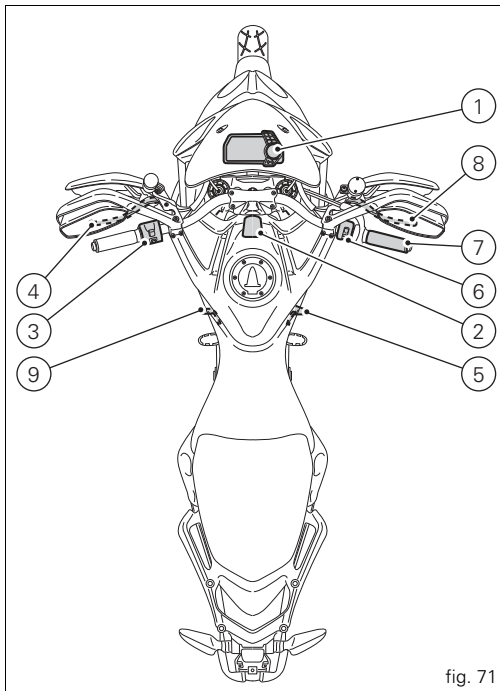

fig. 71

## “Hands free” system

The Hands free system consists of:

- 1) Hands free lock;
- 2) Antenna;
- 3) Active key;
- 4) Passive key;
- 5) Electric cap (optional).

The “Hands free” lock (1, fig. 72) is located on the front of the tank. The door must be removed to access it (8, fig. 74).



### Note

In the USA version the door (8, fig. 74) is not present.

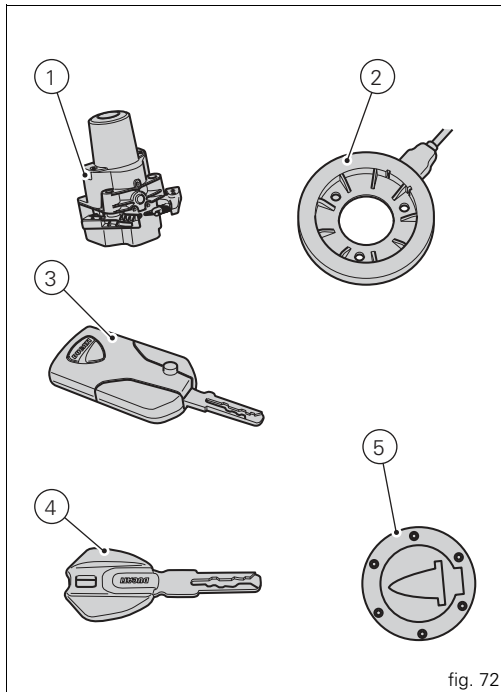

## Hands free system Key-On and Key-Off

Key-On consists in turning on the hands free system and all of its electronic devices.

Key-Off consists in turning off the hands free system and all electronic devices, and makes sure the engine is turned off. Key-On is done using the button (6) on the handlebar on the right switch or using the emergency button (7) on the Hands free lock (1, fig. 72).

Key-Off is done using the button (6, fig. 73) on the handlebar on the right switch or using the emergency button (7) on the Hands free lock (1, fig. 72).

### Warning

The button (7) is hidden under the door (8). Remove it to access the button (7). In the USA version the door (8) is not present.

### Note

The use of one of the two buttons (6) or (7) does not exclude the other, ex.: if I turn it on with one, I can turn it off with the other and vice versa.

Key-On can only occur in the presence of one of the two keys (3, fig. 72) or (4, fig. 72) or using the pin code.

Key-Off can also occur without a key (3, fig. 72) or (4, fig. 72).

Key-Off occurs when the speed of the motorcycle is equal to zero, pressing the button (6) on the handlebar or by pressing the Hands free button (7); at a speed other than zero, only by pressing the Hands free button (7).

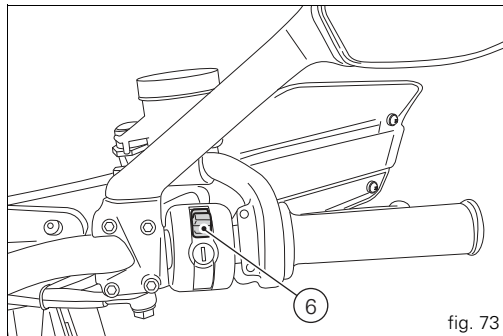

fig. 73

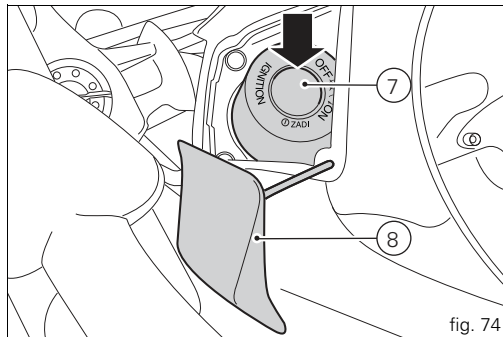

fig. 74



## Note

When the battery is discharged, the active key (3, fig. 72) acts like a passive key (4, fig. 72). The instrument panel displays the discharged battery status.

The mechanical part (A) of the key (3) is used to open the fuel cap and the seat and bag lock.

The metal part (A) of the key (3) remains hidden inside its housing, it exits by pressing the button (B, fig. 76).



## Note

With the vehicle in Key-On and "engine off", if the presence of the active key (3, fig. 76) is not detected for thirty consecutive seconds, the motorcycle will turn off automatically without any action by the rider.

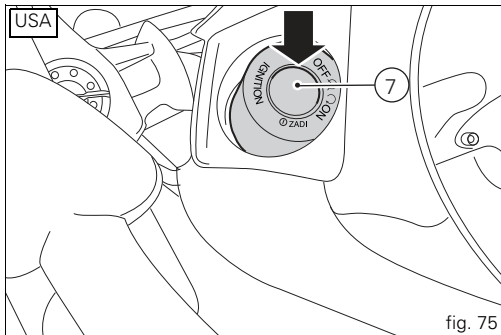

fig. 75

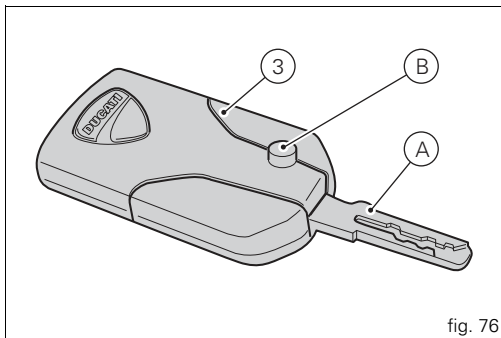

fig. 76



## E Key-On/Key-Off using the red key on the handlebar with the active key

A Key-On can be performed by pressing the red key (6) on the handlebar in the HANDS FREE ON/OFF position and in the presence of the active key (3, fig. 72).



### Note

The active key (3, fig. 72) has a range of approx. 1.5 m, therefore it must be located within this range.

Key-Off can be performed by pressing the red key (6) on the handlebar in the HANDS FREE ON/OFF position. It can be done also without the key (3, fig. 72) only if the motorcycle speed is equal to zero.

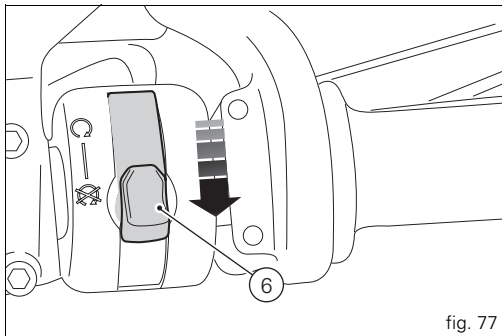

fig. 77

## Key-On/Key-Off using the key on the Hands free lock with the active key

Key-On can be performed by pressing the button (7) on the Hands free lock (1, fig. 72) and with the presence of the active key (3, fig. 72).



### Note

In the USA version the door (8) is not present



### Note

The active key (3, fig. 72) has a range of approx. 1.5 m, therefore it must be located within this range.

Key-Off can be performed by pressing the button (7) on the Hands free lock (1, fig. 72), also without the key (3, fig. 72).

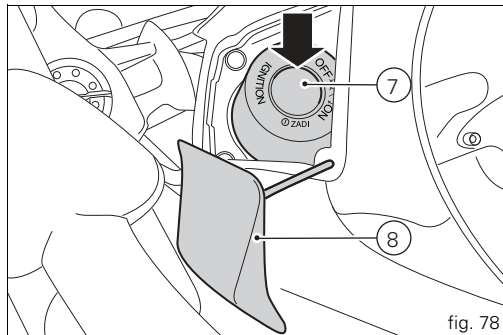

fig. 78

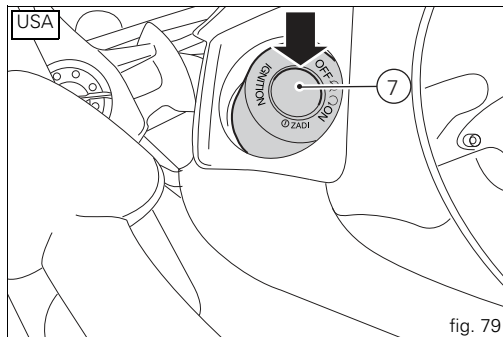

fig. 79

## E Key-On/Key-Off using the red key on the handlebar with the passive key

A Key-On can be performed by pressing the red button (6) on the handlebar in the HANDS FREE ON/OFF position and in the presence of the passive key (4, fig. 72).



### Note

The passive key (4, fig. 72) has a range of a few cm, therefore the key (4, fig. 72) must be positioned near the antenna (2).

Key-Off can be performed by pressing the red button (6) on the handlebar in the HANDS FREE ON/OFF position. It can be done also without the key (4, fig. 72) only if the motorcycle speed is equal to zero.

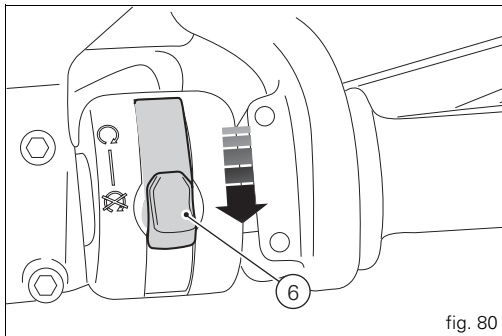

fig. 80

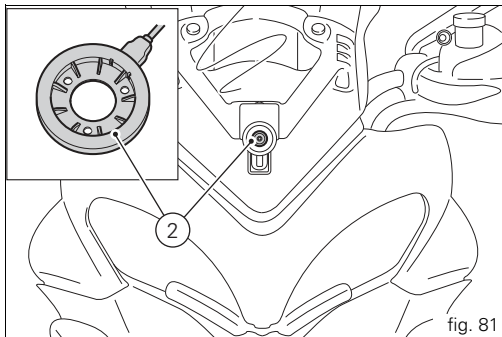

fig. 81

## Key-On/Key-Off using the key on the Hands free lock with the passive key

Key-On can be performed by pressing the button (7) on the Hands free lock and with the presence of the passive key (4, fig. 72).



### Note

In the USA version the door (8) is not present



### Note

The passive key (4, fig. 72) has a range of a few cm, therefore the key (4, fig. 72) must be positioned near the antenna.

Key-Off can be performed by pressing the button (7) on the Hands free lock (1, fig. 72), also without the key (4, fig. 72).

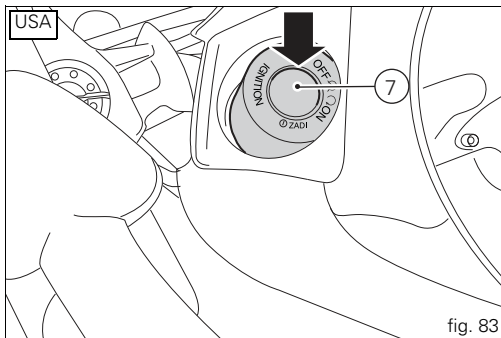
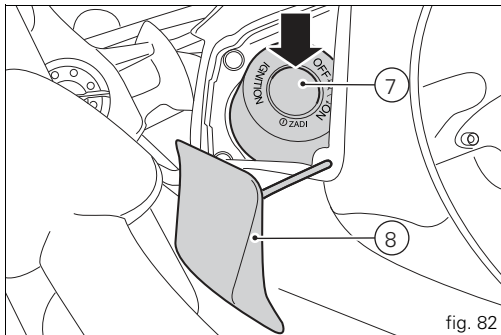

## Key-On/Key-Off using the pin code (immobilizer release)



### Note

In the USA version the door (8) is not present

Key-On can be performed by pressing the button (7) on the hands free lock (1, fig. 72) without the presence of the keys (3, fig. 72) and (4, fig. 72) and entering the pin code on the dashboard.

Key-Off can be performed by pressing the button (6) on the handlebar / Hands Free key (7) / engine off no key.

After each Key-Off, at the next Key-On if the key is not present the pin code must be entered.

The pin code is entered by the customer when receiving the motorcycle.

The function is not enabled without the pin code.

When the Hands Free button is pressed (7) the instrument panel activates the backlighting and the circular display to be able to enter the four digit pin code. Entering the correct pin turns on the instrument panel and enables engine starting.

The pin must be entered within 120 sec, after which a Key-Off occurs automatically.

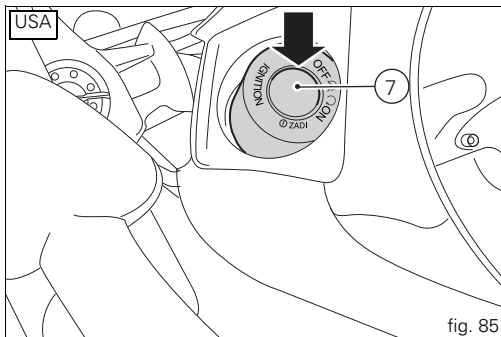
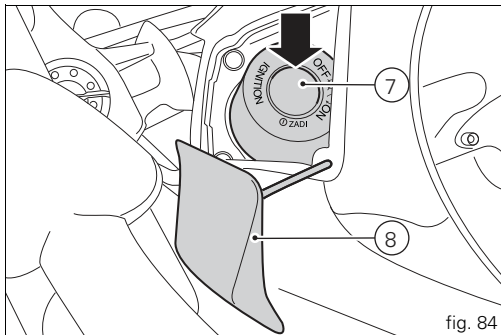

## Entering PIN CODE function for vehicle release

This function turns on the motorcycle “temporarily” in the case of HF (Hands Free) system “malfunctions”.

To activate the function, press the “emergency” Hands Free button (7, fig. 86) lifting the door (8, fig. 86) if the motorcycle cannot be turned on using the normal starter button.



### Note

In the USA version the door (8, fig. 86) is not present

After pressing the button, the instrument panel activates only the circular display (B, fig. 7) (and the backlighting) to be able to enter the 4 digit PIN code.

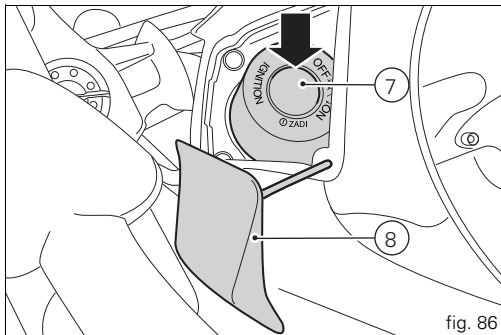

fig. 86

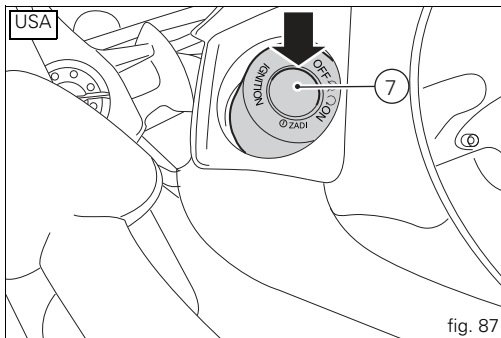

fig. 87

Entering the code:

each time you press the button (2, fig. 8) “▼” the displayed number increases from “0” to “9” and then returns to “0”; to confirm the number, press the reset button (13, fig. 5); repeat the procedure until inserting the fourth digit; press the reset button (13, fig. 5) again to confirm. If the code is incorrect, the instrument panel will return to the initial indication in order to enter the code again.



### Note

There is no limit to the number of times the code can be re-entered; the instrument panel will turn off automatically 120 seconds after an attempt to enter the code.

If the code was entered correctly, the message “PIN OK” will flash on the display for 4 seconds. After 4 seconds, the instrument panel will return to the “normal” view (with all indications active). From this moment, the vehicle can be started using the start button (Key-On).



### Note

The vehicle can be started until a Key-Off is performed; if the problem still persists upon the next starting attempt, repeat the procedure from the beginning in order to start the motorcycle “temporarily”.



### Important

If this procedure is necessary in order to start the vehicle, contact an Authorised Ducati Service Centre as soon as possible to fix the problem.

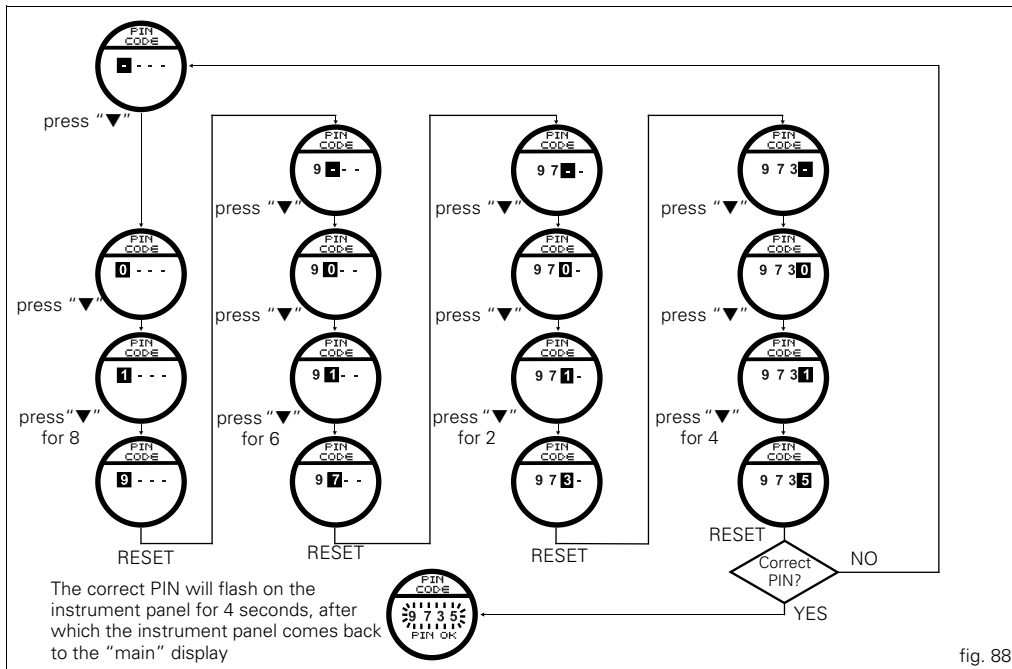







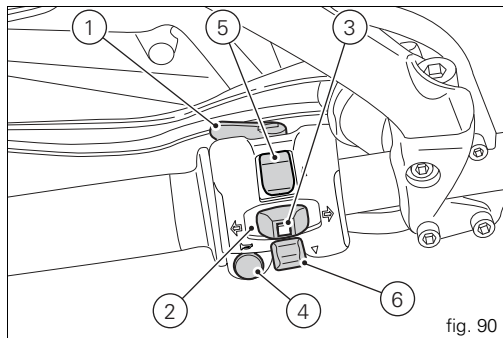
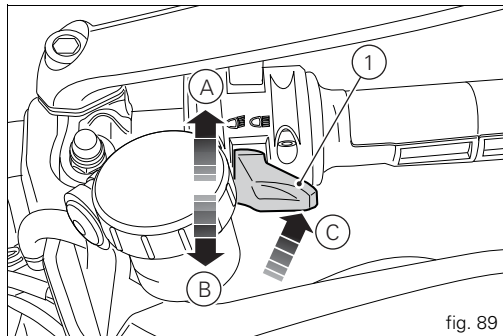

fig. 88



## Lh switch (fig. 89 and fig. 90)

- 1) Dip switch, light dip switch, two positions (fig. 89):  
(A) pushed up  = low beam on;  
(B) pushed down  = high beam on.  
(C) pushed to the side  = high beam flasher (FLASH),  
"Start-Stop lap" function.
- 2) Button  = three-position turn indicator (fig. 90):  
centre position = OFF;  
position  = left turn;  
position  = right turn.
- 3) Turn indicator off, "Riding Style" activation and menu navigation button.
- 4) Button  = warning horn.
- 5) Navigation menu, main display scroll and TRIP1 and TRIP2 reset button.
- 6) Navigation menu, circular Dot-Matrix display scroll button.



## Clutch lever (fig. 91)

Lever (1) disengages the clutch. It features a dial adjuster (2) for lever distance from the twistgrip on handlebar.

The lever distance can be adjusted through 10 clicks of the dial (2). Turn clockwise to increase lever distance from the twistgrip. Turn the adjuster counter clockwise to decrease lever distance.

When the clutch lever (1) is operated, drive from the engine to the gearbox and the rear wheel is disengaged. Correct use of the clutch lever is very important in all riding situations, especially when moving off.



### Warning

Any adjustment of clutch lever must be carried out when motorcycle is stationary.



### Important

Using the clutch properly will prolong the life of the engine and prevent any damage to components in the transmission.



### Note

It is possible to start the engine with the side stand down and the gearbox in neutral. When starting the bike with a gear engaged, pull the clutch lever (in this case the side stand must be up).

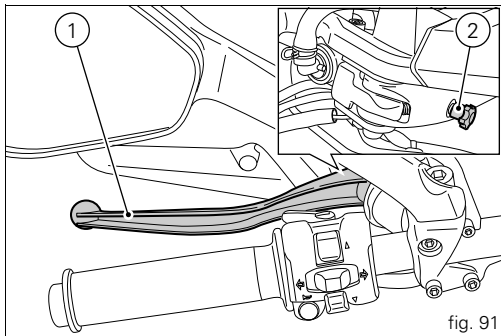

## RH switch (fig. 92)

- 1) Red ON/OFF switch.
- 2) Black ENGINE START button

The switch (1, fig. 92) has three positions:

- A) centre: RUN OFF. In this position, the engine cannot be started and all electronic devices are off.
- B) pushed down: ON/OFF. In this position, the system can be turned on (Key-On) and off (Key-Off).
- C) pushed up: RUN ON. The engine can only be started in this position, pushing the black button (2).

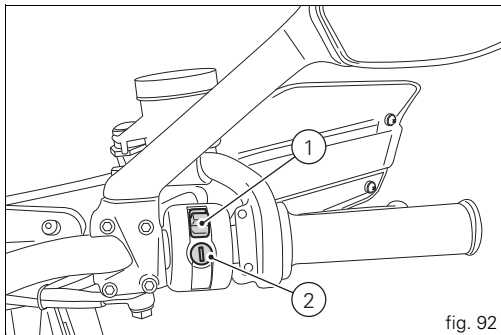

fig. 92

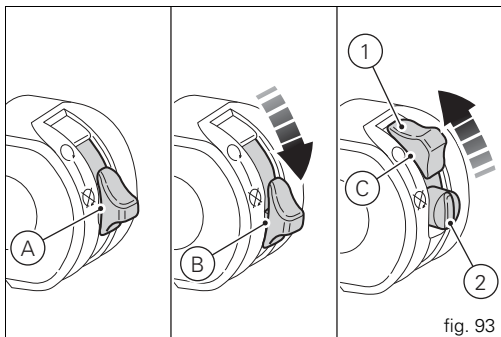
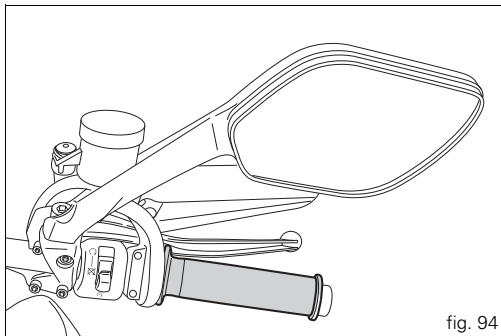

fig. 93

## Throttle twistgrip (fig. 94)

The twistgrip on the right handlebar opens the throttles. When released, it will spring back to the initial position (idling speed).



## Front brake lever (fig. 95)

Pull in the lever (1) towards the twistgrip to operate the front brake. The system is hydraulically operated and you just need to pull the lever gently.

The brake lever (1) has a dial (2) for adjusting the distance between lever and twistgrip on the semihandlebar.

The lever distance can be adjusted through 10 clicks of the dial (2). Turn clockwise to increase lever distance from the twistgrip. Turn the adjuster counter clockwise to decrease lever distance.

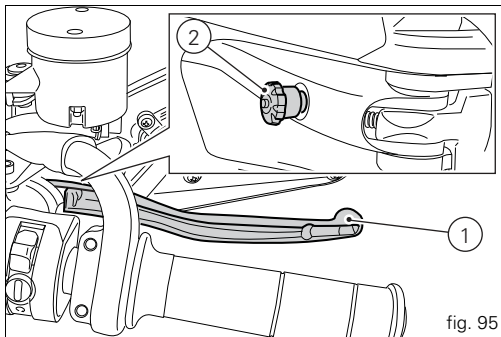

## Rear brake pedal (fig. 96)

Push down on the pedal with your foot to operate the rear brake.

The system is controlled hydraulically.

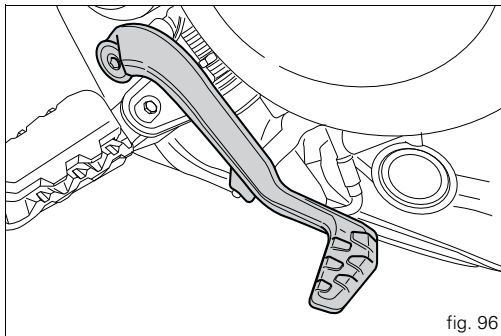

## Gear change pedal (fig. 97)

When released, the gear change pedal automatically returns to rest position N in the centre; This is indicated by the instrument panel light N (3, fig. 4) coming on.

The pedal can be moved:

down = press down the pedal to engage the 1<sup>st</sup> gear and to shift down. The N light will go out.

upwards= lift the pedal to engage 2<sup>nd</sup> gear and then 3<sup>rd</sup>, 4<sup>th</sup>, 5<sup>th</sup> and 6<sup>th</sup> gears.

Each time you move the pedal you will engage the next gear.

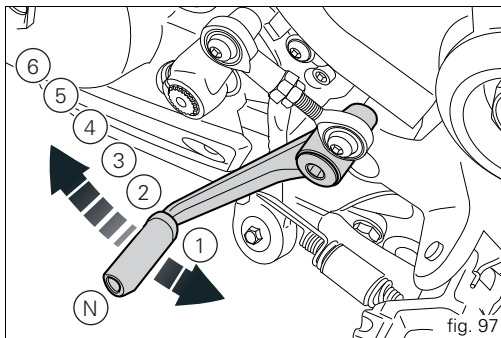

## Adjusting the position of the gearchange and rear brake pedals

The position of the gearchange and rear brake pedals in relation to the footrests can be adjusted to suit the requirements of the rider.

Adjust the pedals as follows:

### Gear change pedal (fig. 98)

Use an open ended spanner to hold the spherical end on the rod (1) on the flat (2) and loosen the counter nut (3).

Turn the screw (4) to detach the rod completely from the gear change lever.

Turn the rod (5), until the gear change pedal is set to the desired position.

Tighten the screw (4) to secure the gearchange lever to the rod (5).

Tighten the counter nut (3) onto the spherical end (5).

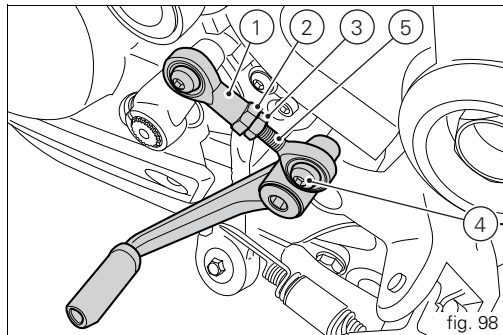

## Rear brake pedal (fig. 99)

loosen counter nut (7).

Turn pedal stroke adjusting screw (6) until pedal is in the desired position.

Tighten the counter nut (7).

Operate the pedal by hand to check that there is 1.5 to 2 mm of freeplay before the brake bites.

If not, adjust the length of the master cylinder pushrod as follows.

Slacken off the counter nut (10) on the pushrod.

Screw the pushrod (8) into the front fork (9) to increase the freeplay, or screw it out to reduce it.

Tighten the counter nut (10) and recheck the pedal freeplay.

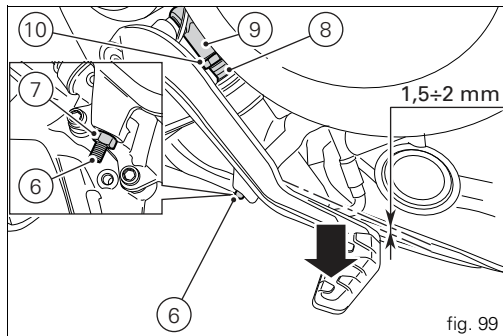

# Main components and devices

## Position on the vehicle (fig. 100)

- 1) Tank filler plug.
- 2) Seat lock.
- 3) Side stand.
- 4) Power outlet.
- 5) Rear-view mirrors.
- 6) Front fork adjusters.
- 7) Rear shock absorber adjusters.
- 8) Catalytic converter.
- 9) Exhaust silencer (see "Warning" on page 128).

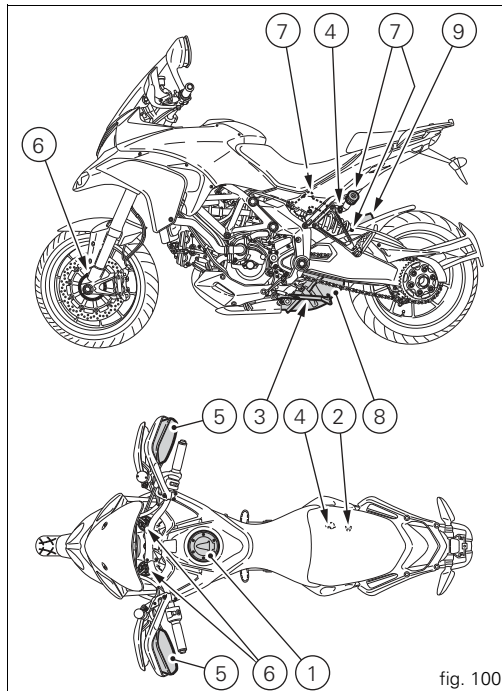

fig. 100



## Tank filler plug

### Opening

Lift the cover (1, fig. 101) and insert the active or passive key into the lock. Give the key a 1/4 turn clockwise to unlock. Lift the plug (2, fig. 102).

### Closing

Close the cap (2) with the key inserted and press it into its seat. Remove the key and replace the lock cover (1).



### Note

The cap can only be closed with the key inserted.



### Warning

Always make sure you have properly refitted (see page 131) and closed the plug after each refuelling.

### Electric fuel cap opening (optional)

The electric cap (2, fig. 102) opens after every key-off within 60 seconds operating the lever (1, fig. 101) located on it.

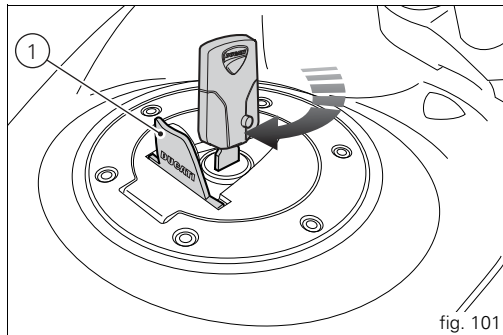

fig. 101

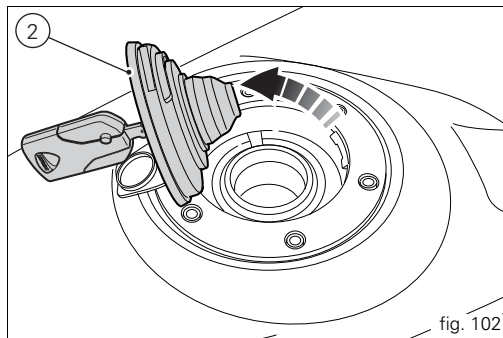

fig. 102

## Seat lock

By operating the lock (1, fig. 103) the passenger seat can be removed to access the tool kit compartment and the rider seat to access the battery and other devices.

## Removal of the seats

Insert the active or passive key into the lock (1) and rotate it clockwise until you hear the release click in the passenger seat.

To remove the passenger seat (2, fig. 104) lift up the front part and pull it forward to free the rear hook (3) on the bottom of the seat.

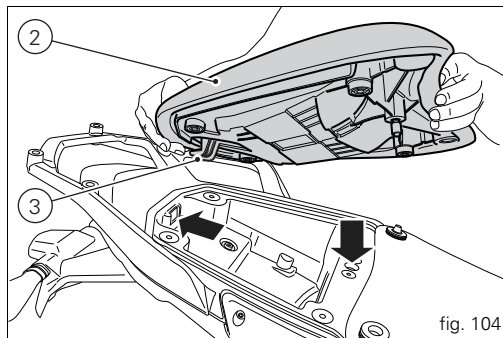
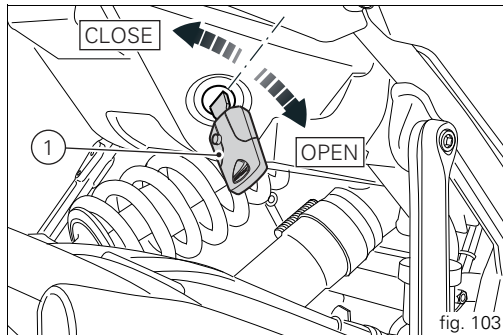

**E** To remove the rider seat (4, fig. 105) remove the rear part from the pin (5) on the frame. Pull it backwards and at the same time push the front part of the rider seat downwards to unhook it from the pins (6, fig. 106) on the tank.

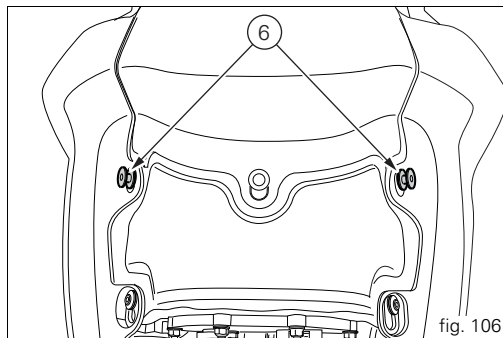
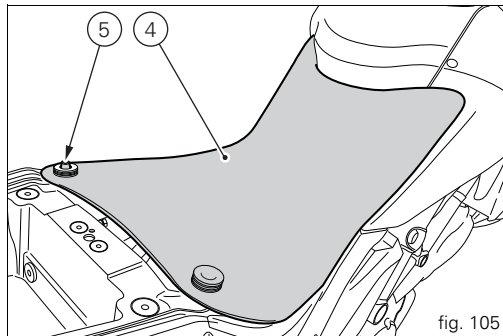

## Refitting

Position the front part of the rider seat (4), with slots (7, fig. 107), in the pins (6, fig. 106) of the tank.

Push on the front end of the rider seat to move the pins (6) to the bottom of the slots (7).

Insert the rear part of the rider seat into the pin (5, fig. 105) of the frame.

Insert the rear hook (3, fig. 104) into the opening in the tail guard and lower the front part of the passenger seat (2) until you hear the pin click in the latch.

Make sure that the passenger seat is properly secured by gently pulling it upwards.

Remove key from the lock (1, fig. 103).

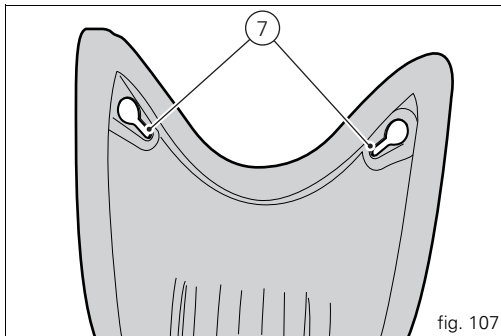

## Helmet cable

Remove the passenger seat and the rider seat as described in the paragraph "Removal of the seats" on page 113. Pass the cable (1, fig. 109) through the helmet and insert the ends of the cable in the frame pin (2, fig. 108). Leave the helmet hanging and refit the passenger seat and the rider seat to hold it in place.



### Warning

This device protects the helmet against theft when the motorcycle is parked. Do not leave the helmet attached when riding the motorcycle; it could interfere with your movements and cause loss of control of the motorcycle.

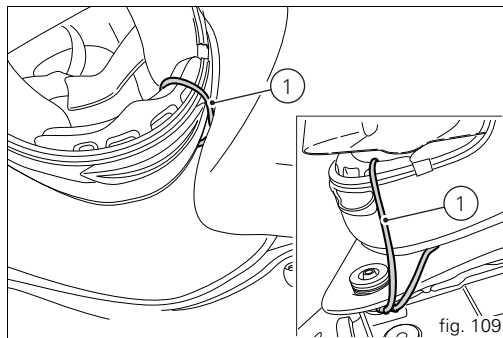
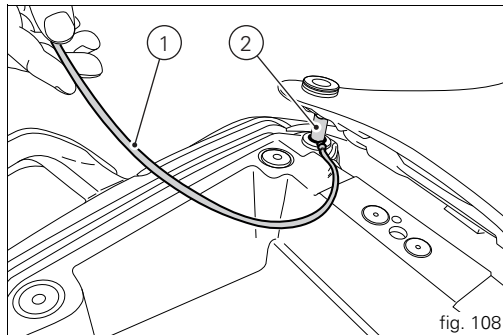

## Side stand (fig. 110)

### Important

Before lowering the side stand, make sure that the bearing surface is hard and flat.

Do not park on soft or pebbled ground or on asphalt melt by the sun heat and similar or the motorcycle may fall over.

When parking on a slope, always park with the rear wheel on the downhill side.

To pull down the side stand, hold the motorcycle handlebars with both hands and push down on the side stand (1) with your foot until it is fully extended. Tilt the motorcycle until the sidestand is resting on the ground.

### Warning

Do not sit on the motorcycle when it is supported on the sidestand.

To move the side stand to its rest position (horizontal position), lean the motorcycle to the right while lifting the thrust arm (1) with your foot.

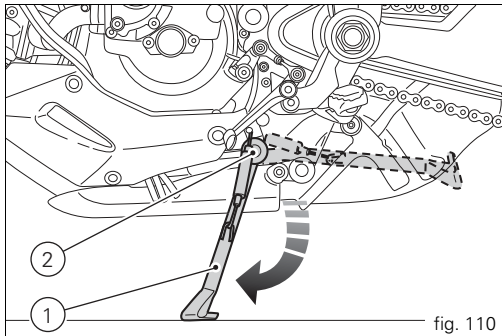

### Note

Check for proper operation of the stand mechanism (two springs, one into the other) and the safety sensor (2) at regular intervals.

### Note

The engine can be started with the sidestand down and the gearbox in neutral. If starting with a gear engaged, pull in the clutch lever (in this case the sidestand must be up).

## Power outlet

The motorcycle has two power outlets to power the accessories. The outlets are protected by a 10 A fuse located in the rear fuse box.

The power outlets are positioned on the left (1, fig. 111) and right (2, fig. 112) sides of the motorcycle behind the passenger pedal support bracket.

### Important

When the engine is off, do not leave accessories connected to the power outlets for a long period of time as the motorcycle battery could run flat.

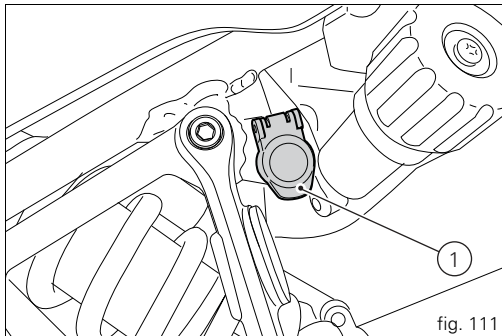

fig. 111

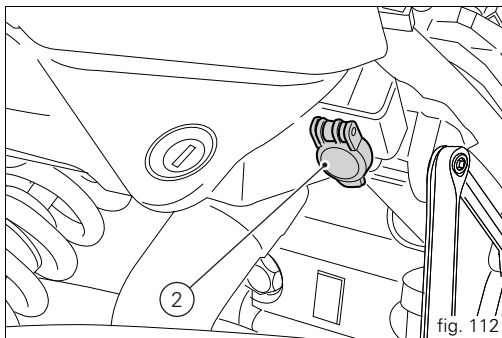

fig. 112

## Adjusting the front fork

The front fork used on this motorcycle has rebound, compression and spring preload adjustment. The settings are adjusted using external adjuster screws.

- 1) to adjust rebound damping (fig. 113);
- 2) to adjust spring preload (fig. 113);
- 3) to adjust compression damping (fig. 114).

Park the motorcycle in a stable position on its side stand. Turn the adjuster (1) on fork leg top with a flat screwdriver to adjust rebound damping.

Turn the adjusting screws (1 and 3) to adjust the dampening. Turn the screw all the way in to set the hardest damping (position "0"). This will be your starting point. Starting from this position, turning anticlockwise, you can count the turns. To change preload of the spring inside each fork leg, turn the hex. adjuster (2, fig. 113) with a 22 mm hexagon wrench, starting from the fully open position (clockwise).

STANDARD factory setting is as follows:

Compression: 1 and a half turns;

Rebound: 2 turns.

Spring preload: FULLY OPEN (anticlockwise).

### Important

Adjust both fork legs to same settings.

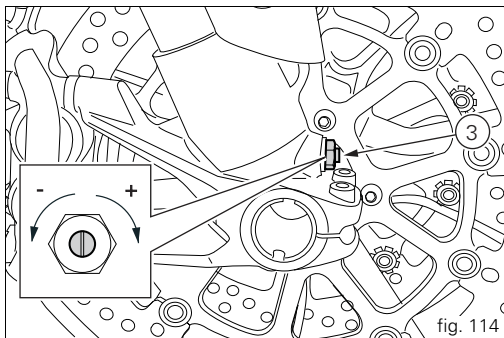
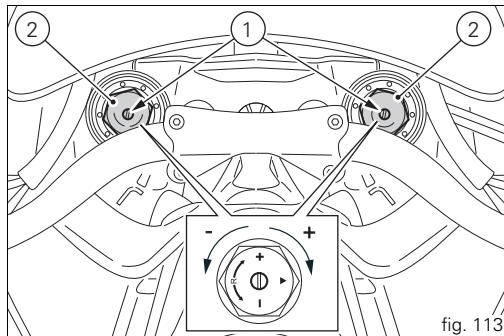



## E Adjusting the rear shock absorber

The rear shock absorber has external commands that enable you to adjust the setting to suit the load on the motorcycle.

The adjuster (1, fig. 115) located on the lower connection holding the shock absorber to the swingarm adjusts the damping during the rebound phase (return).

The knob (2, fig. 115), located on the left side of the motorcycle, adjusts the preload of the shock absorber external spring.

The adjuster (3, fig. 116) located on the expansion reservoir of the shock absorber adjusts the damping during the compression phase.

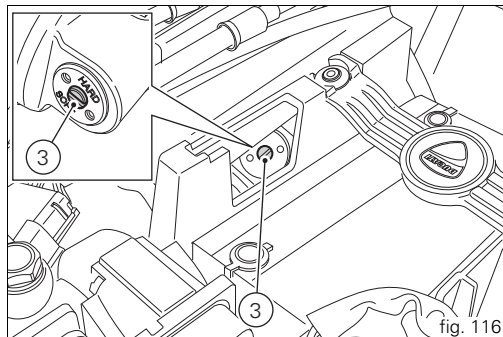
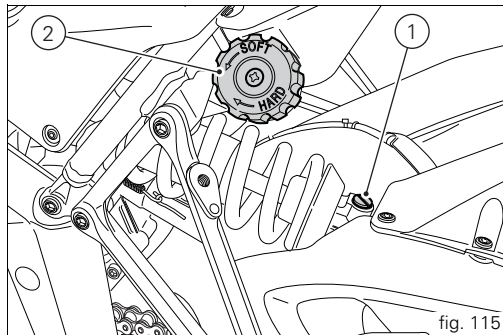

To access the adjuster (3, fig. 116) remove the rider seat and the cover (4, fig. 117) located to the side of the battery. The adjuster (3, fig. 116) can be turned through the hole in the battery support.

Turning the adjusters (1) and (3) or the knob (2) in a clockwise direction increases the damping or the preload; they decrease turning them in the opposite direction.

STANDARD setting; from fully closed (clockwise) loosen:

adjuster (1) by 9 clicks;

knob (2) by 18 mm (max. 18 - min. 25 mm);

adjuster (3) by 1.5 clicks.



### Warning

The shock absorber is filled with gas under pressure and may cause severe damage if taken apart by unskilled persons.

When carrying a passenger and luggage, set the rear shock absorber spring to proper preload to improve motorcycle handling and keep safe clearance from the ground. You may find that rebound damping needs adjusting as well.

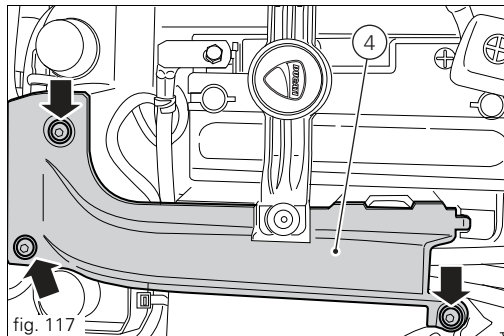

# E Riding the motorcycle

For the first 100 km use the brakes gently. Avoid sudden or prolonged braking. This will allow the friction material on the brake pads to bed in against the brake discs.

To allow all the mechanical moving parts in the motorcycle to adapt to one another, and to avoid shortening the life of the main engine components, it is advisable to avoid sudden acceleration and running the engine at high rpm for too long, especially uphill.

It is also advisable to check the drive chain frequently and ensure that it is lubricated as required.

## Running-in recommendations

### Maximum rpm (fig. 118)

Rpm limits to be observed during the running-in period and in normal use:

- 1) up to 1000 km;
- 2) from 1000 to 2500 km.

### Up to 1000 km

During the first 1000 km, keep an eye on the rev counter. It should never exceed 5,500÷6,000 rpm.

During the first hours of riding, it is advisable to run the engine at varying load and rpm, though still within recommended limit.

For this reason, roads with numerous bends and hilly areas are ideal for running in the engine, brakes and suspension.

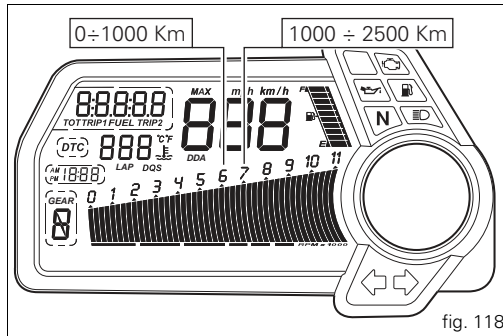

fig. 118

## From 1000 to 2500 km

At this point, you can squeeze some more power out of your engine. However never exceed 7,000 rpm.



### Important

Throughout the running-in period, be careful to stick to the recommended maintenance schedule and periodic service intervals indicated in the warranty booklet. Failure to follow these instructions releases Ducati Motor Holding S.p.A. from any liability whatsoever for any engine damage or shorter engine life.

Keeping to the running-in recommendations will ensure longer engine life and reduce the need for overhauls and re-tuning.

## Pre-ride checks



### Warning

Failure to carry out these checks before starting may result in damage to the motorcycle and injury to rider.

Before starting, check the following points:

#### FUEL LEVEL IN THE TANK

Check fuel level in the tank. Fill tank if needed (page 131).

#### ENGINE OIL LEVEL

Check the oil level in the sump through the sight glass. Top up if needed (page 154).

#### BRAKE AND CLUTCH FLUID

Check fluid level in the relevant reservoirs (page 136).

#### COOLANT LEVEL

Check coolant level in the expansion reservoir. Top up if needed (page 135).

#### TYRE CONDITION

Check tyre pressure and condition (page 152).

#### CONTROLS

Work the brake, clutch, throttle and gear change controls (levers, pedals and twistgrips) and check for proper operation.

#### LIGHTS AND INDICATORS

Make sure lights, indicators and horn work properly. Replace any burnt-out bulbs (page 146).

#### KEY-OPERATED LOCKS

Ensure that fuel filler plug (page 112) and seat (page 113) are firmly secured.

#### STAND

Make sure side stand operates smoothly and is in the correct position (page 117).



### Warning

In case of malfunction, do not ride the motorcycle and contact a Ducati Dealer or authorised Service Centre.

## Engine on/off



### Warning

Before starting the engine, become familiar with the controls you will need to use when riding (page 92).



### Warning

Never start or run the engine indoors. Exhaust gases are toxic and may lead to loss of consciousness or even death within a short time.

In the presence of the active or passive key, perform a Key-On (turning on the “Hands free” system and all on-board electronic devices) by pushing the red switch (1, fig. 119), on the right side of the handlebar, downward.

The instrument panel will perform the initialisation and will control the onboard systems, turning on all lights in sequence, from the bottom to the top, for a few seconds. After this check, only the N green light (2, fig. 120) and the red light  (3, fig. 120) must remain on.



### Warning

The side stand must be fully up (in a horizontal position) as its safety sensor prevents engine start when down.

After Key-On, but with the engine not yet started, the system will perform a Key-Off automatically if the presence of the active key is not detected within 10 seconds.

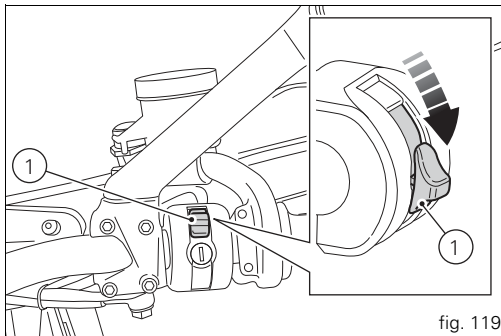

fig. 119

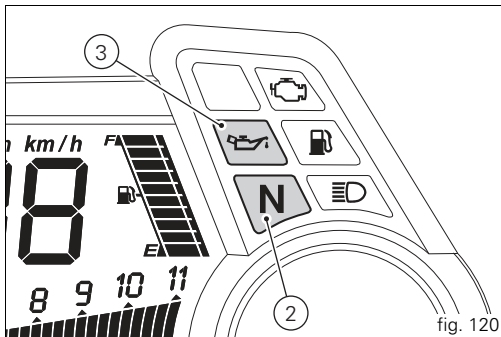

fig. 120

## Note

It is possible to start the engine with side stand down and the gearbox in neutral. When starting the bike with a gear engaged, pull the clutch lever (in this case the side stand must be up).

Move the red switch (1) up to uncover the black button (4, fig. 121).

Push the button (4) to start the engine.

## Important

Do not rev the engine when cold. Allow some time for oil to reach all points that need lubricating.

The red oil pressure warning light should go out a few seconds after the engine has started.

The engine will shut off by turning the red key (1, fig. 121) on the handlebar to RUN OFF.

## Note

To turn on the "Hands free" system and all electronic onboard systems, refer to page 93 "Hands Free System".

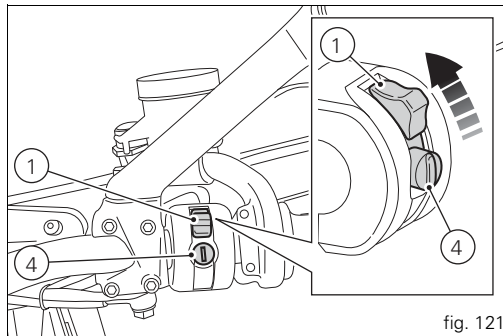

fig. 121

## Moving off

- 1) Disengage the clutch by squeezing the clutch lever.
- 2) Push down the gear change lever firmly with the tip of your foot to engage first gear.
- 3) Raise the engine revs by turning the throttle twistgrip while gradually releasing the clutch lever. the motorcycle will start moving off.
- 4) Release the clutch lever completely and accelerate.
- 5) To shift up, close the throttle to slow down engine, disengage the clutch, lift the gear change lever and let go of clutch lever.

To change down, proceed as follows: release the twistgrip, pull the clutch control lever, shortly speed up to help gears synchronise, shift down (engage next lower gear) and release the clutch.

The controls should be used correctly and timely: when riding uphill do not hesitate to shift down as soon as the motorcycle tends to slow down, so you will avoid stressing the engine and the motorcycle abnormally.

## Important

Avoid sudden acceleration, as this may lead to misfiring and transmission snatching. The clutch lever should not be pulled longer than necessary after gear is engaged, or friction parts may overheat and wear out.

## Braking

Slow down in time, change down to use the engine brake, then apply both brakes. Pull the clutch lever before stopping the motorcycle, to avoid sudden engine stop.



## Warning

Use both brake lever and pedal for effective braking. Never use the brake controls harshly or suddenly as you may lock the wheels and lose control of the motorcycle. When riding in the rain or on slippery surfaces, braking will become less effective. Always use the brakes very gently and carefully when riding under these conditions. Any sudden manoeuvres may lead to loss of control. When tackling long, high-gradient downhill road tracts, shift down gears to use engine braking. Apply one brake at a time and use brakes sparingly. Keeping the brakes applied continuously causes the friction material to overheat and dangerously reduces braking effectiveness. Underinflated or overinflated tyres reduce braking efficiency, handling accuracy and stability in a bend.



## Stopping the motorcycle

Reduce speed, shift down and release the throttle twistgrip. Change down to engage first gear and then neutral. Apply the brakes and bring the motorcycle to a complete stop. Turn off the engine moving the red switch (1, fig. 123).

## Parking

Park the stopped motorcycle on the side stand. Turn the handle completely to the left or right. If this operation is performed within 60 seconds of turning off the engine, the message "Waiting for lock" (fig. 122) will appear on the circular display of the instrument panel for approx. 5 seconds. If you want to enable the steering lock, move the red switch (1, fig. 123) downward during this interval.

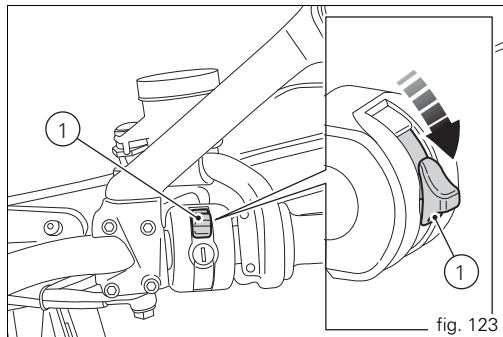
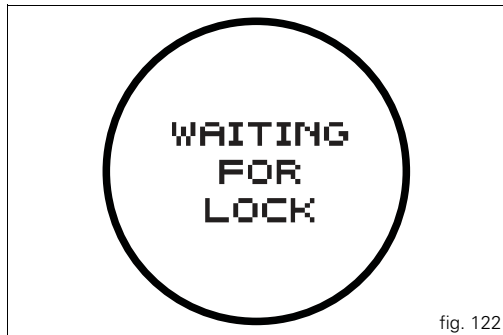

If the steering lock was enabled correctly, the locked steering indication (fig. 124) will appear on the circular display of the instrument panel for 5 seconds.

The steering lock disables at Key-On.

If the "Hands free" system was not able to release the steering, an error message (fig. 125) will appear on the display.

In this case, it is recommended to turn the vehicle off and on (Key-Off / Key-On) holding the handlebar pressed down to the end stop. If the signal remains (and the steering does not "release") contact an Authorised Ducati Service Centre.

In order to make the motorcycle visible at night or in poorly illuminated areas, the "Parking" function can be activated within 60 seconds of turning off the vehicle by turning on the front and rear parking lights.



fig. 124

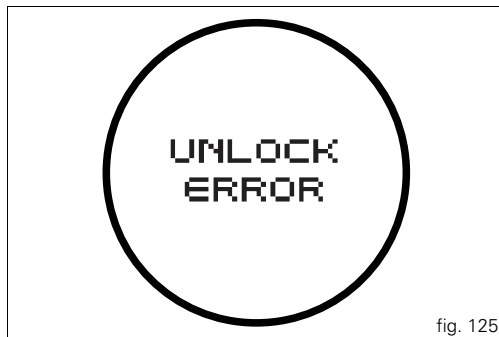

fig. 125

Press (2, fig. 126) for at least 3 seconds: the indication of the activated function (fig. 127) will appear on the circular display of the instrument panel for 5 seconds and the lights will remain on for 2 hours. After this period of time, they will turn off automatically.



### Note

If there is a sudden interruption in the battery voltage during the "Parking" function, the instrument panel will disable this function when the voltage is restored.



### Important

The frequent use of this function can considerably reduce the battery charge; it is recommended to use this function only when necessary.



### Warning

The exhaust system might be hot, even after engine is switched off; pay particular attention not to touch exhaust system with any body part and do not park the vehicle next to inflammable material (wood, leaves etc.).



### Warning

Using padlocks or other locks designed to prevent motorcycle motion, such as brake disc locks, rear sprocket locks, and so on is dangerous and may impair motorcycle operation and affect the safety of rider and passenger.

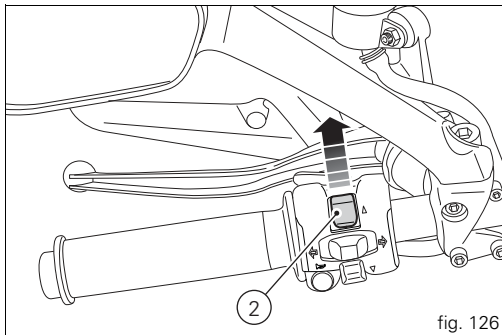

fig. 126



fig. 127

## Refuelling (fig. 128)

Never overfill the tank when refuelling. The fuel level should always be below the rim of the filler recess.



### Warning

Use low-lead fuel with a minimum octane rating of 95 RON (see "Top-ups" table, page 163).

Be sure there is no fuel trapped in the filler recess.



### Warning (USA version)

Use low-lead fuel with a minimum octane rating of 90 (RON+MON)/2 (see "Top-ups" table, page 163).

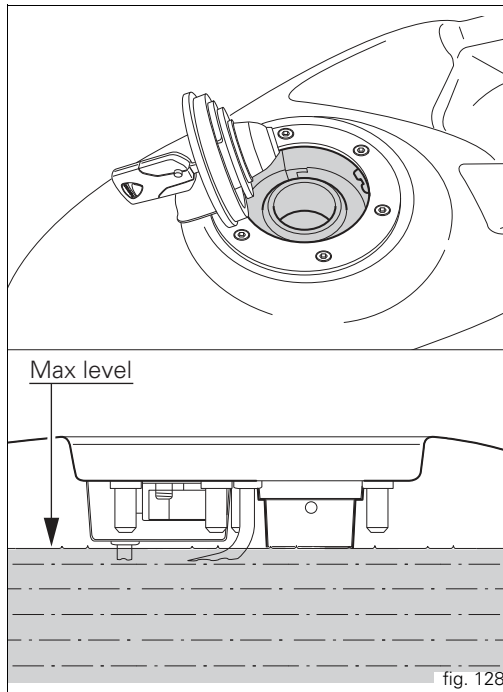

## Tool kit and accessories (fig. 129)

The compartment under the passenger seat (1) holds:

- an Owner's manual and tool kit (2) including:
- 1 90° needle with rubber scraper;
- 2 rubber cylinders for punctures;
- 2 high pressure spray cans;
- 2 valve adaptors (if not provided with the spray cans);
- 1 5 mm Allen wrench x gravel guard;
- 1 10 mm Allen wrench x eccentric clamp;
- 1 pin wrench for the eccentric;
- 1 extension per pin wrench, 10 mm Allen wrench, screwdriver;
- 1 chain tensioning gauge (for its use refer to the instructions at page 144);
- 1 Phillips screwdriver or 10 mm wrench for battery;

To access the compartment remove the passenger seat.

The following are also provided as standard:

- front semi-mudguard kit;
- long rear mudguard kit.

## Front semi-mudguard kit (fig. 130)



### Important

To fit the front semi-mudguard kit, ALWAYS contact a Ducati Dealer or Authorised Service Centre.

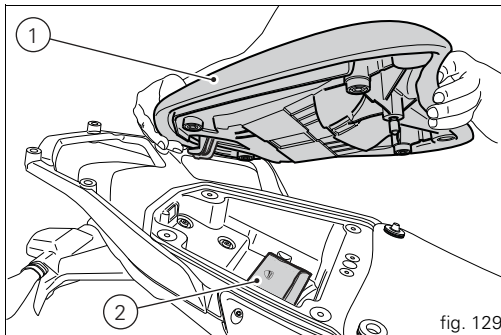

fig. 129

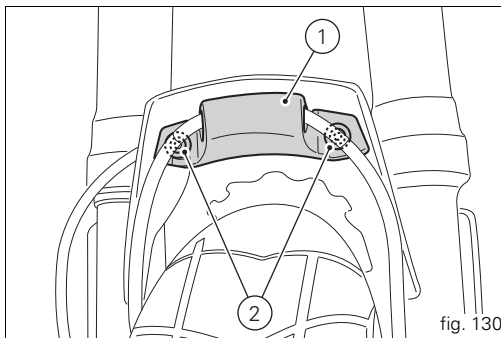
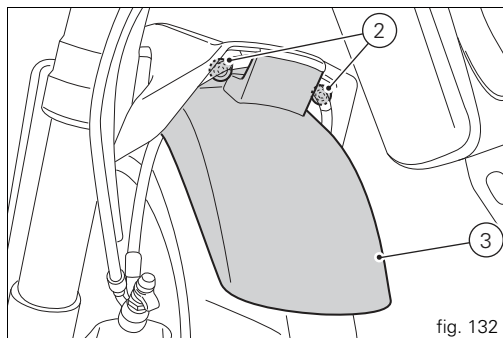
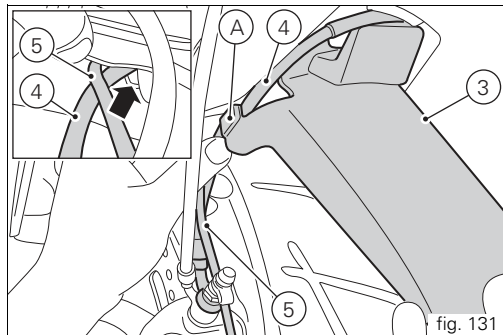

fig. 130

Remove the pipe grommet (1, fig. 130) unscrewing the two screws (2, fig. 130).

Position the front semi-mudguard kit (3) on the front mudguard, housing the front brake pipe (4) and the front phonic wheel cable (5) as shown in the figure (fig. 132). Fasten the slot (A) in the fissure in the front mudguard (1) and start the two previously removed screws (2). Tighten the two screws (2) to a torque of  $3.5 \text{ Nm} \pm 10\%$ .



## Long rear mudguard kit

### Important

To fit the long rear mudguard kit, ALWAYS contact a Ducati Dealer or Authorised Service Centre.

Remove the rear mudguard (1) unscrewing the three screws (2).

Position the long rear mudguard kit (3) on the swingarm, starting the previously removed screws (2).

Tighten the screws (2) to a torque of  $5 \text{ Nm} \pm 10\%$ .

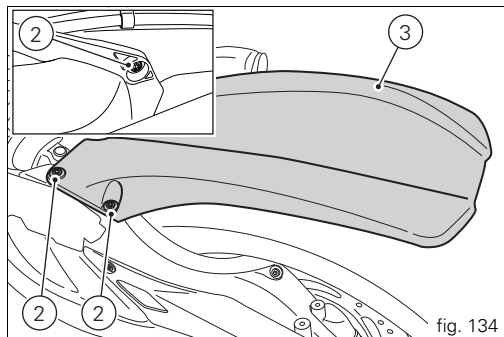
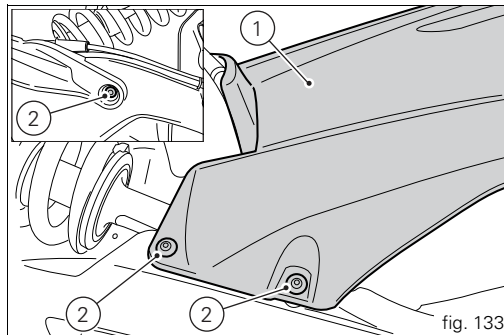

# Main maintenance operations



## Warning

Place the motorcycle upright on a flat surface and make sure the engine is cold before proceeding.

E

## Checking and topping up coolant level

Check the coolant level in the expansion reservoir on the right-hand side of the headstock.

Steer the handlebar completely to the left and check that the level is between the MIN and MAX marks on the side of the expansion reservoir.

Top up if the level is below the MIN mark.

Unscrew the filler plug (1) and add a mixture consisting of water and antifreeze SHELL Advance Coolant or Glycoshell (35÷40% of the volume) up to the MAX level.

Refit the plug (1).

This type of mixture ensures the best operating conditions (the coolant starts to freeze at -20 °C/-4 °F).

Cooling circuit capacity: 4.10 cu. dm (litres).

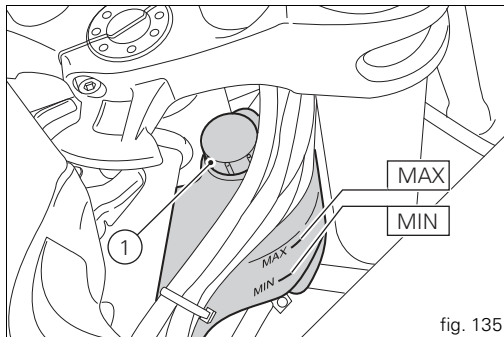



## Checking brake and clutch fluid level

The level must not go below the MIN mark shown on the respective reservoirs (fig. 136 shows the front and rear brake fluid reservoirs, fig. 137 shows the clutch fluid reservoir). If level drops below the limit, air might get into the circuit and affect the operation of the system involved. Brake and clutch fluid must be topped up and changed at the intervals specified in the scheduled maintenance chart reported in the Warranty Card; please contact a Ducati Dealer or authorised Service Centre.

### Important

It is recommended all brake and clutch lines be changed every four years.

## Brake system

If you find exceeding play on brake lever or pedal and brake pads are still in good condition, contact your Ducati Dealer or authorised Service Centre to have the system inspected and any air drained out of the circuit.

### Warning

Brake and clutch fluid can damage paintwork and plastic parts, so avoid contact. Hydraulic oil is corrosive; it may cause damage and lead to severe injuries. Never mix fluids of different qualities. Check that the seals are in good condition.

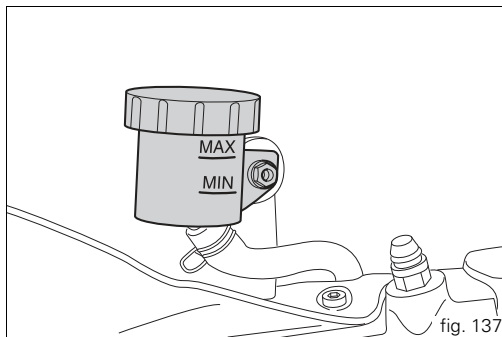
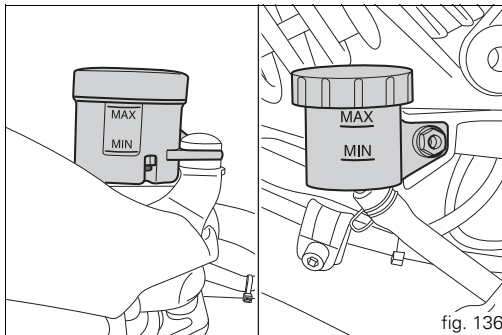

## Clutch system

If the control lever has exceeding play and the transmission snatches or jams as you try to engage a gear, it means that there might be air in the circuit. Contact your Ducati Dealer or authorised Service Centre to have the system inspected and air drained out.



### Warning

Clutch fluid level will increase as clutch plate friction material wears down. Do not exceed the specified level (3 mm above the minimum level).

## Checking brake pads for wear

Check brake pads wear through the inspection hole in the callipers.  
Change both pads if friction material thickness of even just one pad is about 1 mm.



### Warning

Friction material wear beyond this limit would lead to metal support contact with the brake disc thus compromising braking efficiency, disc integrity and rider safety.



### Important

Have the brake pads replaced at a Ducati Dealer or authorised Service Centre.

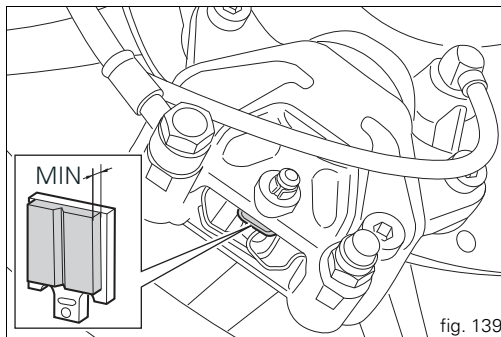
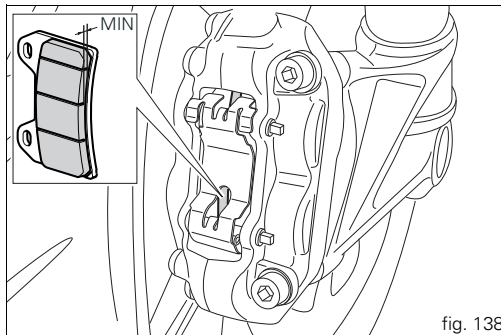

## Lubricating cables and linkages

Check the outer sheath of the throttle control cables for damage at regular intervals. The outer plastic cover should not be flattened or cracked. Work the controls to make sure the cables slide smoothly inside the sheaths: if you feel any friction or catching, have the cable replaced by a Ducati Dealer or Authorised Service Centre.

To avoid this kind of problem with the throttle cable, unscrew the two retaining screws (1, fig. 140) to open the case and then the grease cable ends and pulley (2, fig. 141) with SHELL Advance Grease or Retinax LX2 grease.

### Warning

Close the case carefully after threading the cables onto the pulley.

Refit the cover and tighten the screws (1) to 10 Nm.

To ensure smooth operation of side stand joint, clean off any dirt and apply SHELL Alvania R3 at all points exposed to friction.

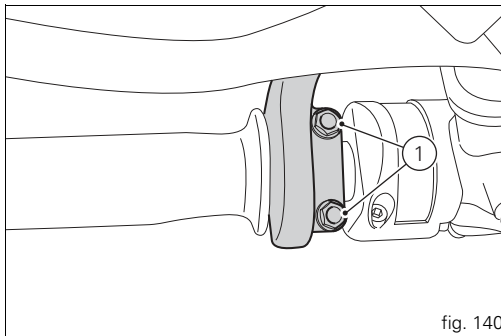

fig. 140

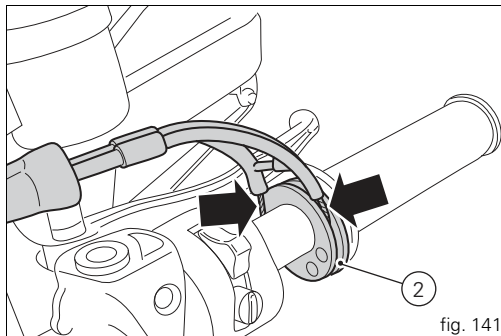

fig. 141

## E Adjusting throttle control free play

The throttle twistgrip must have free play of 1.5 - 2.0 mm in all steering positions, measured on the outer edge of the twistgrip. If necessary, adjust it using the adjusters (1 and 2, fig. 142) located on the headstock on the left-hand side of the vehicle.

Adjuster (1) is for throttle opening, adjuster (2) for closing. Slip the rubber gaiters off the adjusters and loosen the counter nuts (3). Adjust both adjusters proportionally: turn clockwise to increase free play and counter clockwise to reduce free play. When finished, tighten the counter nuts (3) and refit the rubber gaiters to the adjusters.

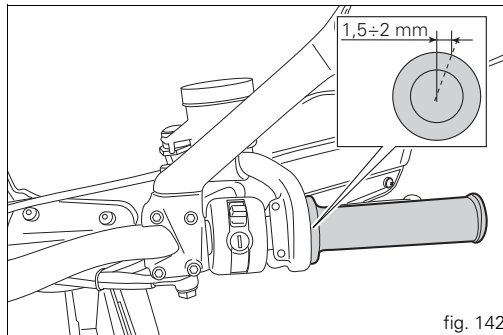

fig. 142

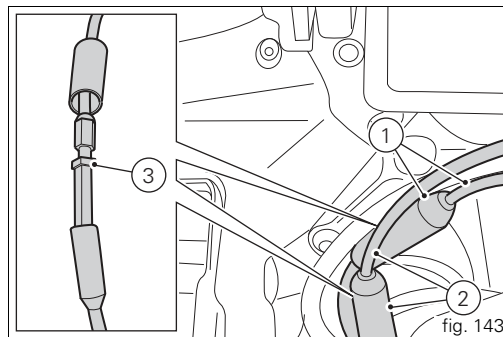

fig. 143

## Charging the battery (fig. 144)

Before charging the battery, it is best to remove it from the motorcycle.

Remove the rider seat, unscrew the screw (1) and remove the bracket (2). Always disconnect the black negative terminal (-) first, then the red positive terminal (+).

### Warning

Batteries develop explosive gases: keep it away from heat sources.

Charge the battery in a ventilated room.

Connect the battery charger leads to the battery terminals> red to the positive terminal (+), black to the negative terminal (-).

### Important

Make sure the charger is off when you connect the battery to it, or you might get sparks at the battery terminals that could ignite the gases inside the cells.

Always connect the red positive (+) terminal first.

Reinstall the battery on its mount and secure the bracket (2) with the screw (1). Apply some grease on the fastening screws to improve conductive capacity and connect the terminals.



### Warning

Keep the battery out of the reach of children.

Charge the battery at 0.9 A for 5÷10 hours.

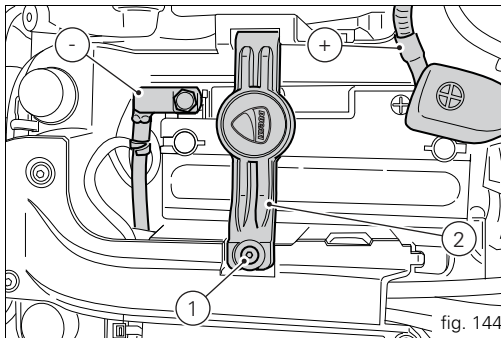

## Checking drive chain tension (fig. 145)

### Important

Have chain tension adjusted by a Ducati Dealer or authorised Service Centre.

Measure chain tension at the centre of the lower section, with the motorcycle on the side stand: lower the chain by pressing down on it only with your finger, release it and measure the distance (A) between the centre of the chain pins and the aluminium section of the swingarm. It must be:  $A = 35 \div 37$  mm.

### Warning

Correct tightening of screws (1, fig. 146) is critical to rider and passenger safety.

### Important

Improper chain tension will lead to early wear of transmission parts.

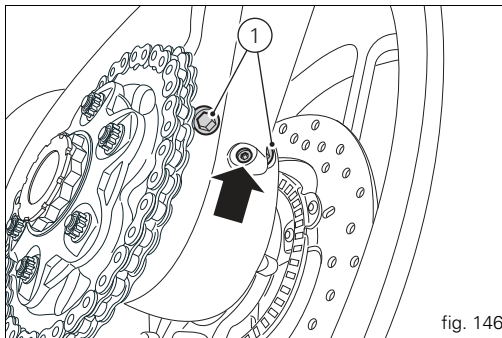
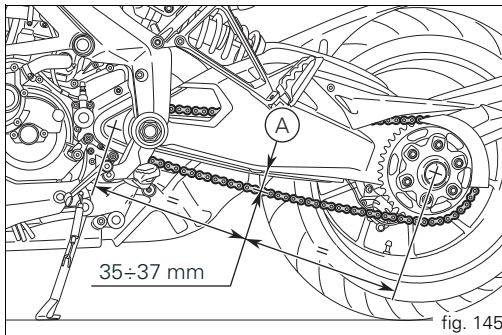

To access the screws (1), remove the rear gravel guards (2, fig. 146) and chain guard (3), unscrewing the three screws (4).

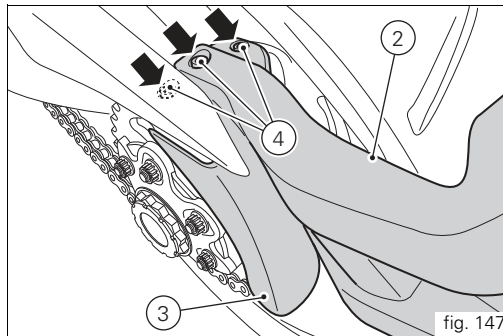

## Lubricating the drive chain

The chain fitted on your motorcycle has O-rings to protect its moving parts from dirt, and to hold the lubricant inside.

The seals might be irreparably damaged if the chain is cleaned using any solvent other than those specific for O-ring chains or washed using steam or water cleaners.

After cleaning, blow the chain dry or dry it using absorbent material and apply SHELL Advance Chain or Advance Teflon Chain on each link.



### Important

Using non-specific lubricants may lead to severe damage to chain, front and rear sprocket.



## E Use of the supplied chain tensioning gauge

For a correct measure the bike must be placed on the side stand.

Always check the chain correct tensioning in the point where it is stretched the most (repeat the gauging on more equidistant points of the chain).

Before proceeding lower the chain with your finger, release it and fit the instrument (1, fig. 148).

The chain tensioning gauge (1) must be inserted between the swingarm and the lower chain slider in correspondence of the slider central fixing point (fig. 149).

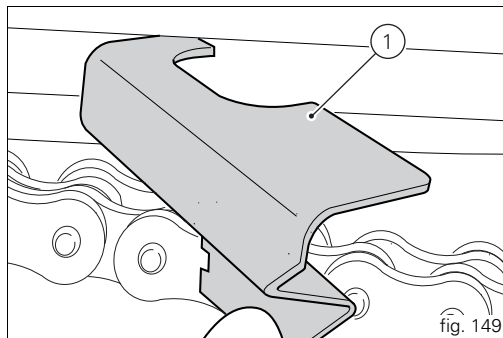
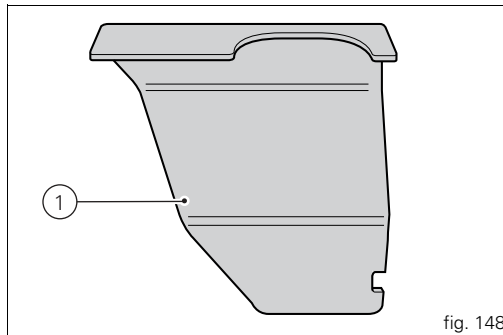

To detect the correct chain tensioning check the correspondence of the chain pins axle (black line in fig. 150), inside the reference notch on the chain tensioning gauge (interval delimited by the arrows in fig. 150). In case the chain pins are above or below such notch (fig. 151), you will have to tension the chain (page 142).



### Important

Have chain tension adjusted by a Ducati Dealer or authorised Service Centre.

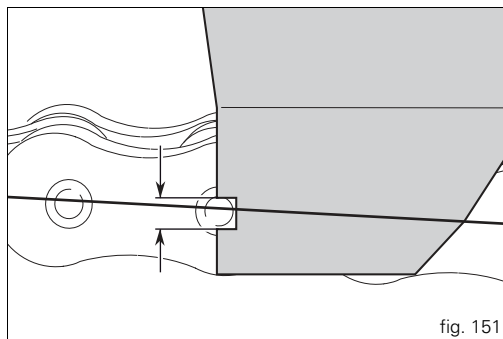
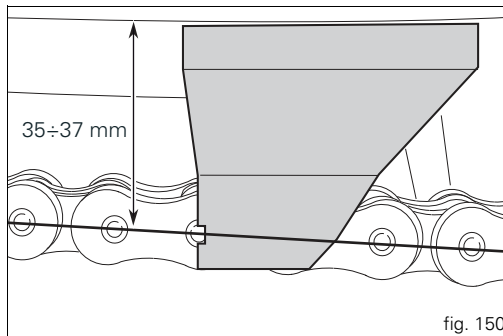

## Replacing the high and low beam bulbs

Before replacing a burnt-out bulb, make sure that the new bulb complies with the voltage and wattage specified in the "Wiring diagram", page 169. Always test the new bulb before refitting any parts you have removed.

fig. 152 shows the locations of the low beam bulbs (LO), high beam bulbs (HI) and the parking light bulb (1).

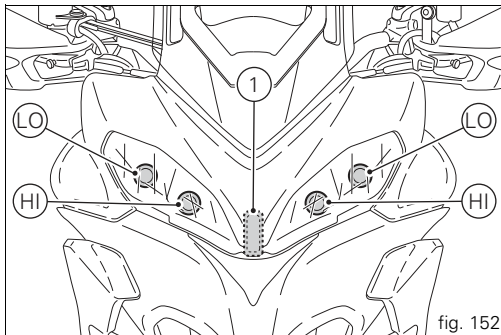

## Headlight

To access the right or left side headlight bulbs, remove the corresponding panel, proceeding as follows.



### Note

The figures show the replacement of the right side headlight bulbs: the procedure is the same for the left side.

Remove the panel cover (2, fig. 153).

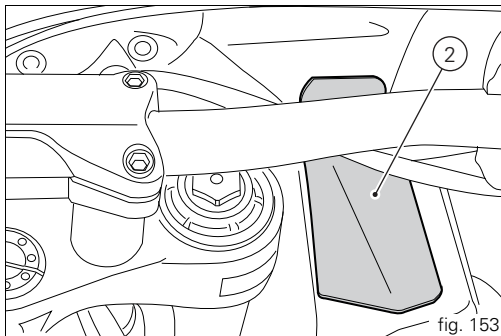

Unscrew the four screws (3, fig. 154) that fasten the panel (4) to top fairing.

Remove the panel (4), lifting the rear part to unhook the tabs from the slots (A, fig. 155) in the top fairing. Detach the connector (5) from the bulb holder (6). Turn the bulb holder with the burnt-out bulb counter clockwise and remove it. Replace the bulb with an identical one.



### Note

Be careful to hold the new bulb at the base only. Never touch the transparent body with your fingers or it will blacken resulting in reduced bulb brilliancy.

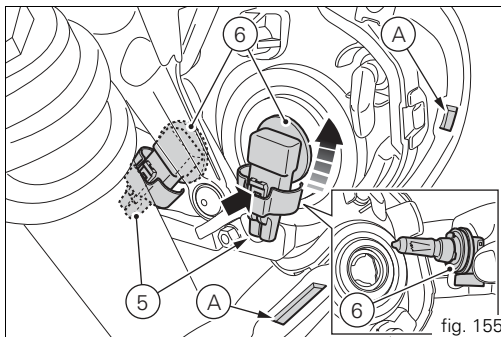
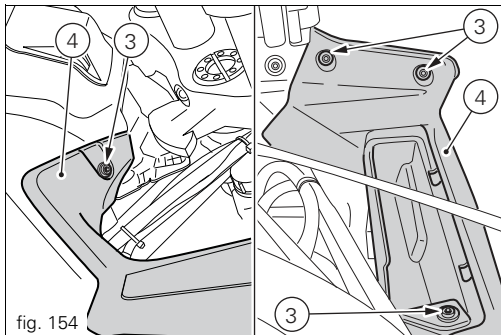

## Refitting

When refitting, turn the bulb holder (6) clockwise to lock it into the headlight body.

Reconnect the connector (5) and refit the structures that were removed being careful to insert the tabs (B, fig. 156) into the slots (A, fig. 155) made in the top fairing.



### Note

To replace the parking light LED bulb, contact an Authorised Ducati Service Centre.

## Rear turn indicators (fig. 157)

Loosen the screw (1) and detach the lens (2) from the turn indicator support.

The bulb has a bayonet-type end fitting: to remove it, push it in and turn it counter-clockwise. Push in the new bulb and turn it clockwise until it clicks into place. Refit the cup (2) by inserting the tab into the corresponding slot in the turn indicator support.

Refit and tighten the screw (1).

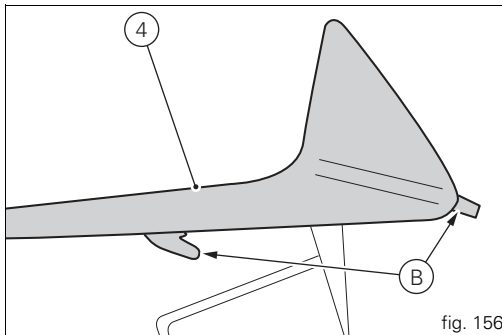

fig. 156

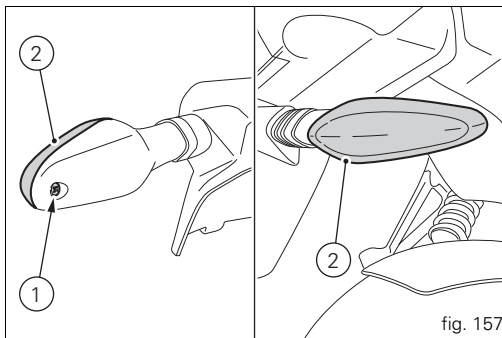

fig. 157

## Number plate light (fig. 158)

To access the bulb in the number plate light open the number plate lens (3), pull the bulb (4) out of the holder and replace it.

## Beam setting (fig. 159)

To check the headlight aim, place the motorcycle upright with the tyres inflated to the correct pressure and one person sitting astride the motorcycle. The motorcycle should be perfectly vertical, with its longitudinal axis at right angles to a wall or screen at a distance of 10 metres. then draw a horizontal line dictated by headlamp centre and a vertical one in line with the longitudinal axis of motorcycle.

If possible, perform this check in dim light. Switch on the low beam headlight.

The height of the light spot (measured at the upper limit between dark and lighted-up area) should not exceed  $\frac{9}{10}$ th of the height from ground of headlamp centre.



### Note

The procedure described here is in compliance with the Italian Standard establishing the maximum height of the light beam.

Owners in other countries should adapt this procedure to the regulations in force in the country where the motorcycle is used.

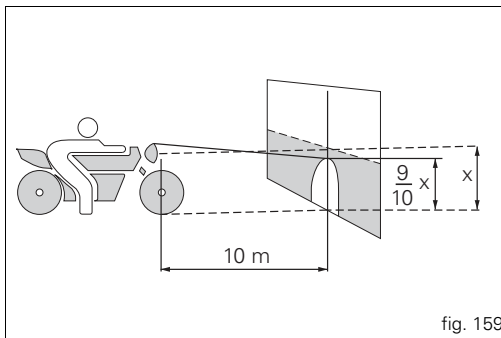
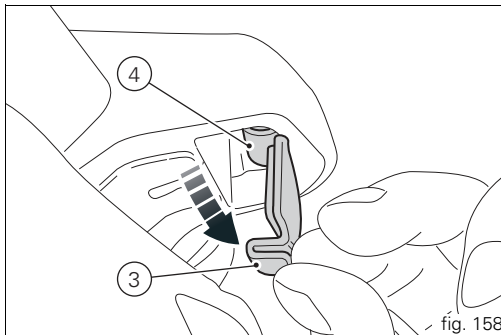

The height of the headlight beam can be adjusted using the adjusting screws (1, fig. 160) located at the bottom on the sides of the headlight.

Turning the screw (1) of the headlight clockwise, the light beam will move downwards: turning it in the opposite direction, will move it upwards.

The side position of the headlight can be adjusted using the adjusting screws (2) located at the centre on the upper part of the headlight. Turning the screws (2) on the left side of the headlight clockwise, the light beam will move to the right: turning it in the opposite direction, will move it to the left.

To move the light beam in the same manner, turn the screw (2) on the right side of the headlight, inverting the direction of rotation.

### Warning

The headlight might fog up if the vehicle is used under the rain or after washing.

Switch headlight on for a short time to dry up any condensate.

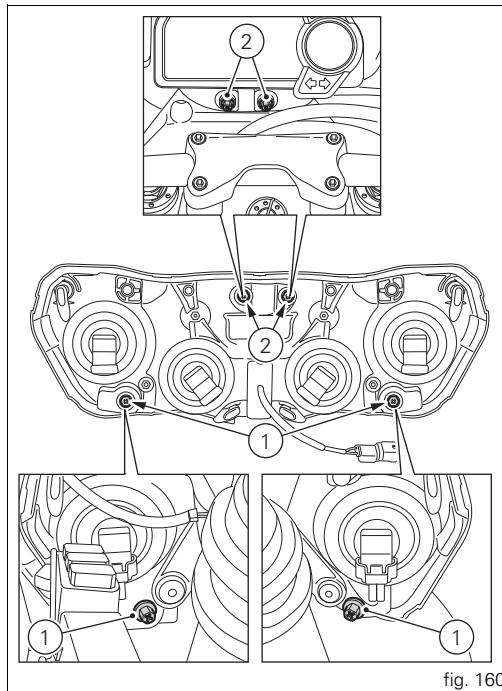
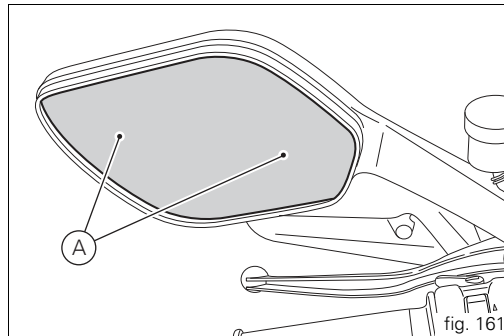

fig. 160

## Rear-view mirror adjustment (fig. 161)

The rear-view mirror can be adjusted manually by pressing points (A).





## Tubeless tyres

Front tyre pressure:

2.50 bar (rider only) - 2.9 bar (with passenger and/or bags)

Rear tyre pressure:

2.50 bar (rider only) - 2.9 bar (with passenger and/or bags)

As tyre pressure is affected by temperature and altitude variations, check and adjust them whenever you are riding in areas where there are large variations in temperature or altitude.

### Important

Check and set tyre pressure when tyres are cold.

To avoid front wheel rim distortion, when riding on bumpy roads, increase tyre pressure by 0.2 - 0.3 bar.

## Tyre repair or change (Tubeless tyres)

With minor punctures, tubeless tyres take a long time to deflate, as they tend to hold the air inside. If you find low pressure on one tyre, check the tyre for punctures.

### Warning

Punctured tyres must be replaced.

Replace with tyres of the original brand and type.

Be sure to tighten the valve dust caps securely to prevent leaks while riding. Never fit tyres with inner tubes, as these can cause the tyre to burst suddenly, with possibly serious consequences for the rider and passenger.

After replacing a tyre, the wheel must be balanced.

### Important

Do not remove or alter the position of the wheel balancing weights.

### Note

Have the tyres replaced at a Ducati Dealer or authorised Service Centre. Correct removal and installation of the wheels is essential.

## Minimum tread depth

Measure tread depth (S, fig. 162) at the point where tread is most worn down.

It should not be less than 2 mm, and in any case not less than the legal limit.



### Important

Visually inspect the tyres at regular intervals for cracks and cuts, especially on the side walls, and bulges or large stains that indicate internal damage. Replace them if badly damaged.

Remove any stones or other foreign bodies stuck in the tread.

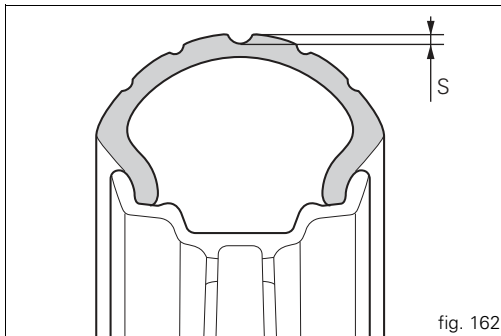

## Checking engine oil level (fig. 163)

Check the engine oil level through the sight glass (1) on the clutch cover. When checking oil level, the motorcycle should be perfectly upright and the engine cold. Oil level should be between the marks on the sight glass. If level is low, top up with SHELL Advance 4T Ultra engine oil. Remove the filler plug (2) and top up to correct level. Replace the filler cap.

### Important

Engine oil and oil filters must be changed by a Ducati Dealer or authorised Service Centre at the intervals specified in the scheduled maintenance chart reported in the Warranty Booklet.

### Oil viscosity

SAE 15W-50

The other viscosity degrees indicated in the table can be used if the local average temperature is within the limits specified for that oil viscosity.

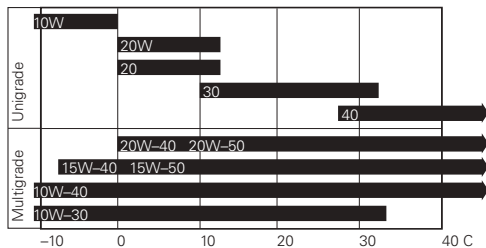
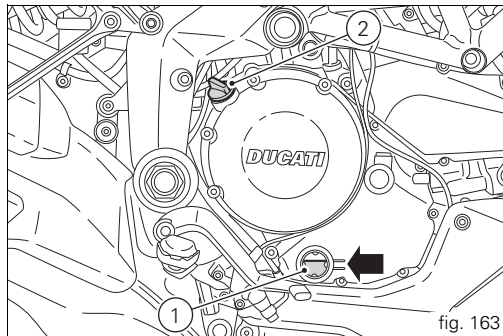

## Cleaning and replacing the spark plugs (fig. 164)

Spark plugs are an important part of the engine and should be checked at regular intervals.

This operation provides an indication of engine condition. Have the spark plugs inspected or replaced at a Ducati Dealer or Authorised Service Centre; they will check the colour of the ceramic insulator of the central electrode (1): an even brown colour is a sign that the engine is in good running order.



### Note

Inspect the centre electrode for wear and check spark plug gap, which should be: 0.8-0.1 mm.



### Important

A gap outside the specified limits will adversely affect engine performance and may lead to difficult starting or erratic idling.

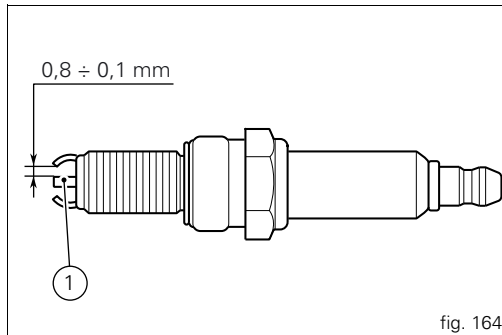

## General cleaning

To preserve the original shine on metal surfaces and paintwork, wash and clean your motorcycle at regular intervals depending on the type of use and according to the particular road conditions. Use specific products, where possible biodegradable. Avoid aggressive detergents or solvents.

Only use water and neutral soap to clean the Plexiglas and the seat.

Clean the aluminium components regularly and by hand. Use specific detergents for aluminium that do NOT contain abrasive substances or caustic soda.



### Note

Do not use abrasive or steel wool sponges, use only a soft cloth.

The warranty does not apply to motorcycles where there is evidence of poor maintenance.



### Important

Do not wash your motorcycle right after use. When the motorcycle is still hot, water drops will evaporate faster and spot hot surfaces. Never clean the motorcycle using hot or high-pressure water jets. Cleaning the motorcycle with a high pressure water jet may lead to seizure or serious faults in the front fork, wheel hub assembly, electric system, headlight (fogging), front fork seals, air inlets or exhaust silencers, with consequent loss of safety.

Clean off stubborn dirt or exceeding grease from engine parts using a degreasing agent. Be sure to avoid contact with drive parts (chain, sprockets, etc.) Rinse with warm water and dry all surfaces with chamois leather.



### Warning

There may be loss of braking efficiency immediately after washing the motorcycle. Never grease or lubricate the brake discs. Loss of braking and further accidents may occur. Clean the discs with an oil-free solvent.



### Warning

The headlight might fog up due to washing, rain or moisture. Switch headlight on for a short time to dry up any condensate.

## Storing the motorcycle

If the motorcycle is to be left unused for a long period, it is advisable to carry out the following operations first:

clean the motorcycle;

empty the fuel tank;

pour a few drops of engine oil into the cylinders through the spark plug seats, then crank the engine by hand a few times so a protective film of oil will spread on cylinder inner walls;

place the motorcycle on a service stand;

disconnect and remove the battery.

Battery should be checked and charged (or replaced, as required) whenever the motorcycle has been left unriden for over a month.

Protect the motorcycle with a specific motorcycle cover that will not damage the paintwork or retain moisture.

This type of motorcycle cover is available from Ducati Performance.

## Important notes

The legislation in some countries (France, Germany, Great Britain, Switzerland, etc.) sets certain noise and pollution standards.

Periodically carry out the required checks and replace parts as necessary, using Ducati original spare parts, in compliance with the regulations in the country concerned.

## Scheduled maintenance chart

### Operations to be carried out by the dealer

List of operations to be performed at 1000 km
Reading of the error memory with DDS on the engine control units and vehicle
Change the engine oil
Change the engine oil filter
Check the indicators and lighting
Check the safety devices (side stand switch, clutch lever switch, right switch engine stop switch and gear position sensor)
Check the battery charge level
Clean the engine oil pick-up filter
Check the coolant level
Check the brake and clutch fluid levels
Check brake discs and pad wear.
Check tyre pressure and wear

List of operations to be performed at 1000 km
---

Check the drive chain tension and lubrication
---

Check the freedom of movement of the side and central stand (if installed)
--

Check the tightening of the safety components (ex. wheel disc nuts, brake callipers, sprocket tightening)
---

Check rubbing points, clearance and freedom of movement of the flexible cables and electric wiring in view
--

Road test of the motorcycle, testing the safety devices
---

Fill out that the service was performed in the Warranty Certificate
---



## Operations to be carried out by the dealer

List of operations to be performed every 12000 km / year (first limit reached)
Reading of the error memory with DDS on the engine control units and vehicle
Change the engine oil
Change the engine oil filter
Check and/or adjust valve clearance (only every 24000 km)
Replace the timing belts (only every 24000 km/60 months)
Replace the spark plugs (only every 24000 km)
Replace the air filter (only every 24000 km)
Replace the front fork fluid (only every 24000 km)
Replace the coolant (only every 24000 km)
Check the indicators and lighting
Check the safety devices (side stand switch, clutch lever switch, right switch engine stop switch and gear position sensor)
Check the battery charge level
Check the coolant level
Check the brake and clutch fluid levels
Check brake discs and pad wear.
Check tyre pressure and wear
Check the drive chain tension and lubrication
Check final drive wear
Check and lubricate the rear wheel shaft (only every 24000 km)

List of operations to be performed every 12000 km / year (first limit reached)
--

Check the freedom of movement of the side and central stand (if installed)
--

Check the tightening of the safety components (ex. wheel disc nuts, brake callipers, sprocket tightening)
---

Check rubbing points, clearance and freedom of movement of the flexible cables and electric wiring in view
--

Road test of the motorcycle, testing the safety devices
---

Fill out that the service was performed in the Warranty Certificate
---

## Operations to be carried out by the customer

List of operations to be performed every 1000 km
--

Check the level of the engine oil
-----------------------------------

Adjust chain tension
----------------------

# E Technical data

Overall dimensions (mm) (fig. 165)

## Weights

Weight in running order without fluids and battery  
189 kg.

Fully laden:  
430 kg.



## Warning

Failure to observe weight limits could result in poor handling and impair the performance of your motorcycle, and could result in loss of control.

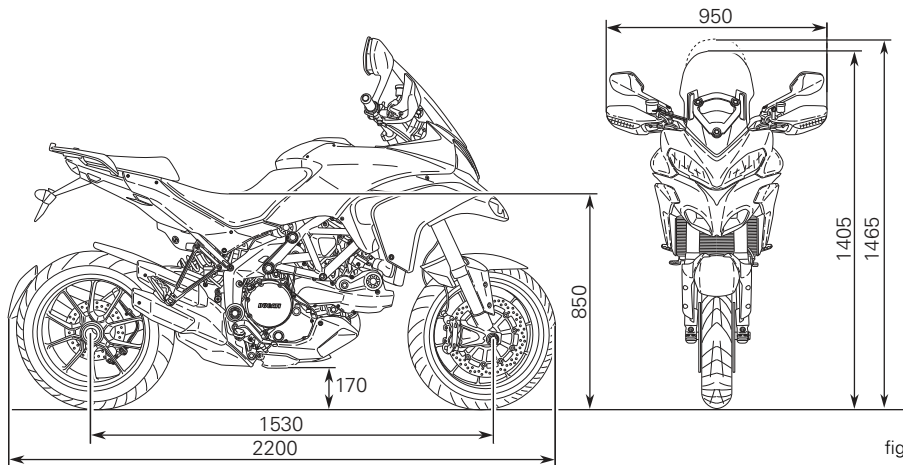

fig. 165

TOP-UPS	TYPE	
Fuel tank, including a reserve of 4 cu. dm (litres)	Unleaded fuel with RON 95 fuel octane rating (at least). For USA version use unleaded fuel with at least 90 fuel octane (RON+MON)/2.	20.0 cu. dm (litres)
Lubrication circuit	SHELL - Advance 4T Ultra	4.10 cu. dm (litres)
Front/rear brake and clutch circuits	Special hydraulic fluid SHELL Advance Brake Dot 4	—
Protection for electrical contacts	SHELL - Advance Contact Cleaner spray for electric systems	—
Front fork	SHELL - Advance Fork 7.5 or Donax TA	720 cc (per fork leg) (*)
Cooling circuit	Antifreeze SHELL - Advance Coolant or Glycoshell 35-40% + water	2.3 cu. dm (litres).

(\*) The value refers to the air column between the free surface of the oil and the end of the sleeve, with the latter fully lowered and without the preload pipe and spring inside the fork leg.



### Important

Do not use additives in fuel or lubricants.

## Engine

Twin cylinder, four-stroke, 90° "L" type, longitudinal.

Bore, mm:

106

Stroke, mm:

67.9

Total displacement, cu. cm:

1198.4

Compression ratio:

11.5±0.5:1

Max crankshaft power (95/1/EC), kW/HP:

110.3 kW/150 HP at 9250 rpm

Max torque at crankshaft (95/1/EC):

12.1 kgm/118.7 Nm at 7500 rpm

Maximum rpm:

10,700 rpm

## Important

Do not exceed the specified rpm limits in any running conditions.

## Timing system

DESMODROMIC (type) with four valves per cylinder, operated by eight rocker arms (4 opening rockers and 4 closing rockers) and two overhead camshafts. It is operated by the crankshaft through spur gears, belt rollers and toothed belts.

### Desmodromic timing system (fig. 166)

- 1) Opening (or upper) rocker.
- 2) Opening rocker shim.
- 3) Closing (or lower) rocker shim.
- 4) Return spring for lower rocker.
- 5) Closing (or lower) rocker.
- 6) Camshaft.
- 7) Valve.

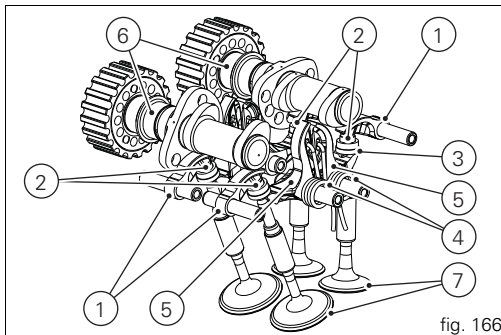

## Performance data

Maximum speed in any gear should be reached only after the correct running-in period with the motorcycle properly serviced at the recommended intervals.



### Important

Failure to follow these instructions will release Ducati Motor Holding S.p.A. from any liability for any engine damage or shortened engine life.

## Spark plugs

Make:

NGK

Type:

MAR9A-J

## Fuel system

MITSUBISHI indirect electronic injection.

Oval throttle body (corresponding diameter):

56 mm

Injectors per cylinder: 1

Holes per injector: 12

Fuel supply: 95-98 RON.



### Warning (USA version)

Use a min. number of 90 octane (RON+MON)/2.

## Brakes

### Front

Semi-floating drilled twin-disc.

Braking material:  
steel.

Carrier material:  
aluminium.

Disc diameter:  
320 mm.

Hydraulically operated by a control lever on right handlebar.

Brake caliper make:  
BREMBO.

Type:  
P4-32 pistons.

Friction material:  
TT 2172

Master cylinder type:  
PR15/18.

### Rear

With fixed drilled steel disc.

Disc diameter:  
245 mm.

Hydraulically operated by pedal on right side.

Make:  
BREMBO

Type:  
P34c pistons.

Friction material:  
TOSHIBA TT 2172 HH.

Master cylinder type:  
P 34c.



### Warning

The brake fluid used in the brake system is corrosive and can cause severe eye and skin injuries in the event of accidental spilling. Wash the affected area with abundant running water.

## Transmission

Wet clutch controlled by the lever on left-hand side of the handlebar.

Transmission from engine to gearbox input shaft via spur gears.

Front sprocket/clutch sprocket ratio:

33/61

6-speed gearbox with constant mesh gears, gear change pedal on left side of motorcycle.

Final drive ratio:

15/40

Total gear ratios:

1<sup>st</sup> gear 15/37

2<sup>nd</sup> gear 17/30

3<sup>rd</sup> gear 20/27

4<sup>th</sup> gear 22/24

5<sup>th</sup> gear 24/23

6<sup>th</sup> gear 25/22

Drive transmitted from gearbox to rear wheel via chain:

Make:

Regina

Type:

136ZRPB

Dimensions:

5/8"x1/16"

Links:

108



## Important

The above gear ratios are approved and should not be modified under any circumstances.

However, if you wish to tune up your motorcycle for competitions or special tracks, Ducati Motor Holding S.p.A. will be pleased to provide information about the special ratios available. Please contact a Ducati Dealer or Authorised Service Centre.



## Warning

If the rear sprocket needs replacing, contact a Ducati Dealer or authorised Service Centre. If improperly replaced, this component could seriously endanger your safety and cause irreparable damage to your motorcycle.



## Frame

ALS 420 steel tube trellis frame.

ALS 450 steel tube trellis frame rear subframe.

Die-cast light alloy connecting side plates, pivoted on the engine.

Steering head angle: 24° 30'

## Wheels

Ten-spoke, light-alloy rims.

### Front

Dimensions:

MT 3.50x17".

### Rear

Dimensions:

MT 6.00x17".

## Tyres

### Front

Tubeless, radial tyre.

Size:

120/70-ZR17

### Rear

Tubeless, radial tyre.

Size:

190/55-ZR17

## Suspension

### Front

Hydraulic upside-down fork provided with outer adjusters for rebound, compression, and preload (for inner springs of fork legs).

Stanchion diameter:

50 mm, TIN-coated.

Wheel travel:

170 mm.

### Rear

The shock absorber is adjustable for rebound and compression, with remote control for spring preload and is adjustable. Its upper section is pivot connected to the frame and the lower section is pivot connected to a light alloy single-sided swingarm. The swinging arm rotates around a pivot shaft that passes through frame and engine.

The whole system gives the bike excellent stability.

Shock absorber stroke:

59.5 mm.

Wheel travel:

170 mm.

## Exhaust system

One-piece stainless steel silencer with aluminium terminals.  
Catalytic converter built into the silencer and lambda sensors on the exhaust pipes at the head output.

## Colour schemes

Ducati Anniversary red 473.101 (PPG);  
Clear lacquer, code 228.880 (PPG);  
Racing Grey frame and black wheel rims.

## Electrical system

Basic electric items are:

Headlight:

low beam bulb type: 2 x H11 (12V-55W);

high beam bulb type: 2xH11 (12V-55W);

parking light: led bulb (13.5V-4W).

Electrical controls on handlebars.

Turn indicators:

front:LED (9.8 V - 2.2 W);

Rear: halogen bulb type RY10W amber (12V-10W).

Horn.

Brake light switches.

Sealed battery, 12V-10 A.

GENERATOR 12V-500W.

ELECTRONIC RECTIFIER, protected by a 30A fuse located on the solenoid starter, behind the battery (C, fig. 169).

Starter motor: 12V-0.7 kW.

Tail light and brake signal:

led (13.5 V- 4.2 W/1.5 W)

Number plate light: bulb type C5W (12-5W).



### Note

See "Replacing the high and low beam bulbs" on page 146 for relevant instructions.

## Fuses

There are twelve fuses that protect the electric components located inside the front and rear fuse boxes, and one on the electric solenoid starter. There is a spare fuse in every box. Refer to the table below to identify the circuits protected by the various fuses and their ratings.

The front fuse box (A, fig. 153) is located inside the left panel and can be accessed by removing the inspection cover. To expose the fuses, lift the box protective cover. Mounting position and ampere capacity are marked on box cover.

### FRONT FUSE BOX LEGEND (A, fig. 167)

Pos.	El. item	Rating
1	Lights	20 A
2	Instrument panel	10 A
3	ECU	5 A
4	Key-sense	15 A
5	Injection relay	20 A
6	Throttle opening starter motor relay (ETV)	10 A
7	Spare	20 A
8	Spare	15 A
9	Spare	10 A

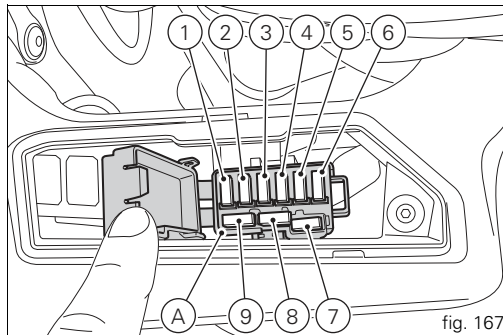

fig. 167

The rear fuse box (B, fig. 168) is positioned on the frame, subframe right side. To access the fuse box, remove the rider seat (see page 113). To expose the fuses, take off the box protective cover. Mounting position and ampere capacity are marked on box cover.

#### REAR FUSE BOX LEGEND (A, fig. 168)

Pos.	El. item	Rating
1	Black Box System (BBS)	7.5 A
2	Power outlets/navigator/alarms	10 A
3	Speed supply sensor	5 A
4	Fans	10 A
5	Diagnosis	7.5 A
6	Spare	10 A
7	Spare	7.5 A
8	Spare	5 A

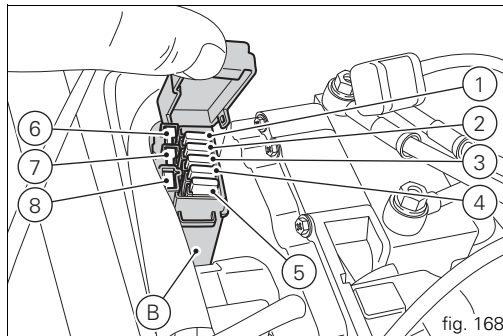

fig. 168

**E** The main fuse (C, fig. 169), is positioned in front of the rear fuse box, on the solenoid starter (D). Remove the fuse cap (E) to reach it.  
A blown fuse is identified by the interrupted centre link (F, fig. 170).



### Important

To prevent short circuits, replace the fuse after the Key-Off.



### Warning

Never use a fuse with a rating other than that specified. Failure to observe this rule may damage the electric system or even cause fire.

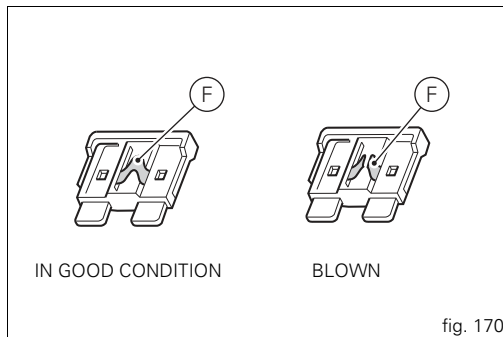
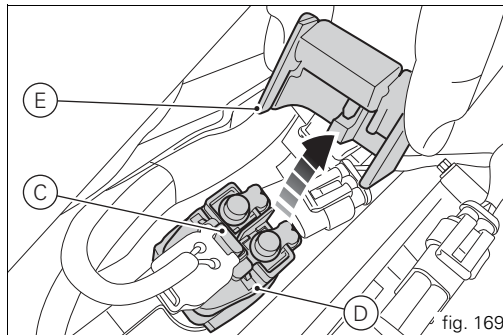

## 1200 Injection /electric system diagram key

- 1) Right-hand handlebar switch
- 2) Immobilizer
- 3) Hands Free relay
- 4) Hands free
- 5) Front fuse box
- 6) Right fan
- 7) Left fan
- 8) Fan relay
- 9) Fuel pump relay
- 10) Ride-by-wire relay (ETV)
- 11) Injection control unit (EMS)
- 12) Navigator
- 13) Left 12V power outlet
- 14) Right 12V power outlet
- 15) Rear fuse box
- 16) Data Acquisition/Diagnosis
- 17) Starter motor
- 18) Fused solenoid
- 19) Battery
- 20) Wiring ground
- 21) Regulator
- 22) Generator
- 23) Fuel pump
- 24) Fuel level
- 25) Rear right turn indicator
- 26) Rear light
- 27) Rear left turn indicator
- 28) Rear wiring loom
- 29) Vehicle control unit (BBS)
- 30) Antitheft alarm
- 31) Exhaust valve starter motor
- 32) Gear sensor
- 33) Rear speed sensor
- 34) Throttle twistgrip position sensor (APS)
- 35) Starter motor - position sensor / ride-by-wire (TPS/ETV)
- 36) Timing/rpm sensor
- 37) Vertical MAP sensor
- 38) Horizontal MAP sensor
- 39) Engine temperature
- 40) Air temperature sensor
- 41) Vertical lambda sensor
- 42) Horizontal lambda sensor
- 43) Oil pressure switch
- 44) Rear stop
- 45) Side stand switch
- 46) Clutch switch
- 47) Front stop
- 48) Main vertical injector
- 49) Main horizontal injector
- 50) Horizontal coil
- 51) Vertical coil
- 52) Left-hand handlebar switch
- 53) Horn
- 54) Front speed sensor
- 55) Antitheft alarm led
- 56) Front left turn indicator
- 57) Instrument panel
- 58) Front right turn indicator
- 59) Low beam headlight relay
- 60) Left low beam headlight
- 61) Left high beam headlight
- 62) Right high beam headlight
- 63) Right low beam headlight
- 64) High beam relay
- 65) Parking light
- 66) Heated handgrip connector
- 67) Front/rear speed sensor power supply device

## Wire colour coding

B Blue  
W White  
V Violet  
BK Black  
Y Yellow  
R Red  
LB Light blue  
GR Grey  
G Green  
BN Brown  
O Orange  
P Pink



### Note

The electric system wiring diagram is at the end of this manual.

# Routine maintenance record



km	DUCATI SERVICE	MILEAGE	DATE
1000			
12000			
24000			
36000			
48000			
60000			



# For United States of America version Only

## Reporting of safety defects

If you believe that your vehicle has a defect which could cause a crash or could cause injury or death, you should immediately inform the National Highway Traffic Safety Administration (NHTSA) in addition to notifying Ducati North America. If NHTSA receives similar complaints, it may open an investigation, and if it finds that a safety defect exists in a group of vehicles, it may order a recall and remedy campaign. However, NHTSA cannot become involved in individual problems between you, your dealer, or Ducati North America. To contact NHTSA, you may either call the Auto Safety Hotline toll-free at 1-800-424-9393 (or 366-0123 in Washington, D.C. area) or write to: NHTSA, 1200 New Jersey Avenue SE W43-488, Washington, D.C. 20590. You can also obtain other information about motor vehicle safety from the Hotline.

## Safety warnings

Traffic Rules vary from jurisdiction to jurisdiction. Know the regulations in your jurisdiction before riding this motorcycle.



### Warning

This motorcycle is designed and intended for use on streets and other smooth, paved areas only. Do not use this motorcycle on unpaved surfaces. Such use could lead to upset or other accident.

## Noise emission warranty

Ducati Motor S.p.A. warrants that this exhaust system, at the time of sale, meets all applicable U.S. EPA Federal noise standards. This warranty extends to the first person who buys this exhaust system for purposes other than resale, and to all subsequent buyers. Warranty claims should be directed to: Ducati North America, 10443 Bandlely Drive, Cupertino, California, 95014 Tel: 001.408.253.0499 - Fax: 001.408.253.4099.

## Noise and exhaust emission control system information

### Source of Emissions

The combustion process produces carbon monoxide and hydrocarbons. Control of hydrocarbons is very important because under certain conditions, they react to form photochemical smog when subjected to sunlight.

Carbon monoxide does not react in the same way, but is toxic. Ducati utilizes lean carburetor settings and other systems to reduce carbon monoxide and hydrocarbons.

## Exhaust Emission Control System

The Exhaust Emission Control System is composed of lean carburetor settings, and no adjustments should be made except idle speed adjustments with the throttle stop screw. The Exhaust Emission Control System is separate from the crankcase emission control system.

## Crankcase Emission Control System

The engine is equipped with a closed crankcase system to prevent discharging crankcase emissions into the atmosphere. Blow-by gas is returned to the combustion chamber through the air cleaner and the throttle body.

### Evaporative Emission Control System

California motorcycles are equipped with an evaporative emission control system which consists of a charcoal canister and associated piping. This system prevents the escape of fuel vapors from the throttle body and fuel tank.

## Tampering warning

Tampering with Noise Control System Prohibited. Federal Law prohibits the following acts or causing thereof:

(1) the removal or rendering inoperative by any person, other than for purposes of maintenance, repair, or replacement, of any device or element of design incorporated into any new vehicle for the purpose of noise control prior to its sale or delivery to the ultimate purchaser or while it is in use; or

(2) the use of the vehicle after such device or element of design has been removed or rendered inoperative by any person.

Among those acts presumed to constitute tampering are the acts listed below:

- (1) Removal of, or puncturing the muffler, baffles, header pipes or any other component which conducts exhaust gases.
- (2) Removal or puncturing of any part of the intake system.
- (3) Lack of proper maintenance.
- (4) Replacing any moving part of the vehicle, or parts of the exhaust or intake system, with parts other than those specified by the manufacturer.

This product should be checked for repair or replacement if the motorcycle noise has increased significantly through use. Otherwise, the owner may become subject to penalties under state and local ordinances.

## Problems that may affect motorcycle emissions

If you are aware of any of the following symptoms, have the vehicle inspected and repaired by your local Ducati dealer.

Symptoms:

Hard starting or stalling after starting.

Rough idle.

Misfiring or backfiring during acceleration.

After-burning (backfiring).

Poor performance (driveability) and poor economy.

## Riding safety

The points given below are applicable for every day motorcycle use and should be carefully observed for safe and effective vehicle operation.

A motorcycle does not provide the impact protection of an automobile, so defensive riding in addition to wearing protective apparel is extremely important.

Do not let protective apparel give you a false sense of security.

Before changing lanes, look over your shoulder to make sure the way is clear. Do not rely solely on the rear view mirror; you may misjudge a vehicle's distance and speed, or you may not see it at all.

When going up steep slopes, shift to a lower gear so that there is plenty of power to spare rather than overloading the engine.

When applying the brakes, use both the front and rear brakes. Applying only one brake for sudden braking may cause the motorcycle to skid and lose control.

When going down long slopes, control vehicle speed by closing the throttle. Use the front and rear brakes for auxiliary braking.

Riding at the proper rate of speed and avoiding unnecessarily fast acceleration are important not only for safety and low fuel consumption but also for long vehicle life and quieter operation.

When riding in wet conditions or on loose roadway surfaces, the ability to maneuver will be reduced. All of your actions should be smooth under these conditions. Sudden acceleration, braking or turning may cause loss of control.

When the roadway is wet, rely more on the throttle to control vehicle speed and less on the front and rear brakes.

The throttle should also be used judiciously to avoid skidding the rear wheel from too rapid acceleration or deceleration.

On rough roads, exercise caution, slow down, and grip the fuel tank with your knees for better stability.

When quick acceleration is necessary as in passing, shift to a lower gear to obtain the necessary power.

Do not down shift at too high an r.p.m. to avoid damage to the engine from overrevving.

Avoiding unnecessary weaving is important to the safety of both the rider and other motorists.

Do not exceed the legal speed limit or drive too fast for existing conditions. High speed increases the influence of any condition affecting stability and the loss of control.

Operate motorcycle only at moderate speed and out of traffic until you have become thoroughly familiar with its operation and handling characteristics under all conditions. This is a very high performance motorcycle, designed and intended for use by experienced careful riders only!

A new motorcycle must be operated according to a special break-in procedure (see Running in recommendations).



### Warning

Before starting engine, check for proper operation of brake, clutch, shifter, throttle controls, correct fuel and oil supply.

Gasoline is extremely flammable and is explosive under certain conditions. Refuell in a well ventilated area with the engine stopped. Do not smoke or allow open flames or sparks when refuelling or servicing the fuel system.

Always close the fuel petcock when the engine is not running to prevent flooding of the throttle body. Do not overfill fuel tank (see instructions page 55).

Motorcycle exhaust contains poisonous carbon monoxide gas. Do not inhale exhaust gases and never run the engine in a closed garage or confined area.

Use only Ducati approved parts and accessories.

This motorcycle was not intended to be equipped with a sidecar or to be used to tow any trailer or other vehicle.

Ducati does not manufacture sidecars or trailers and cannot predict the effects of such accessories on handling or stability, but can only warn that the effects will be adverse and any damage to motorcycle components caused by the use of such accessories will not be remedied under warranty.



## Warning

Do not ride the motorcycle with helmets attached to the hook; the helmets could cause an accident by distracting the operator or interfering with normal vehicle operation.

## Protective apparel

Always wear a helmet. Most motorcycle accident fatalities are due to head injuries.

For safety eye protection, gloves, and high top, sturdy boots should also be worn.

The exhaust system becomes very hot during operation, never touch the exhaust system. Wear clothing that fully covers your legs. Do not wear loose clothing which could catch on the control levers, footrests, wheels, or chain.

Any amount of alcohol will significantly interfere with your ability to safely operate your motorcycle. Don't drink and ride.

## Vehicle identification number (VIN);

Every Ducati motorcycle is identified by two identification numbers (see page 11). fig. A specifically shows the frame identification numbers.

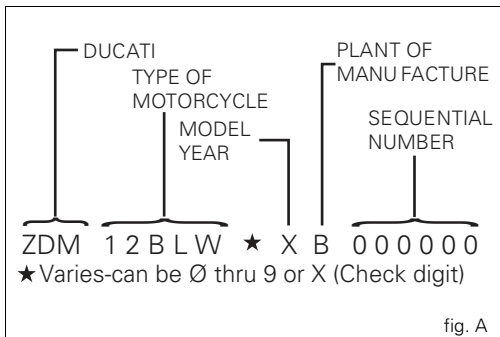

## Label location (fig. B)

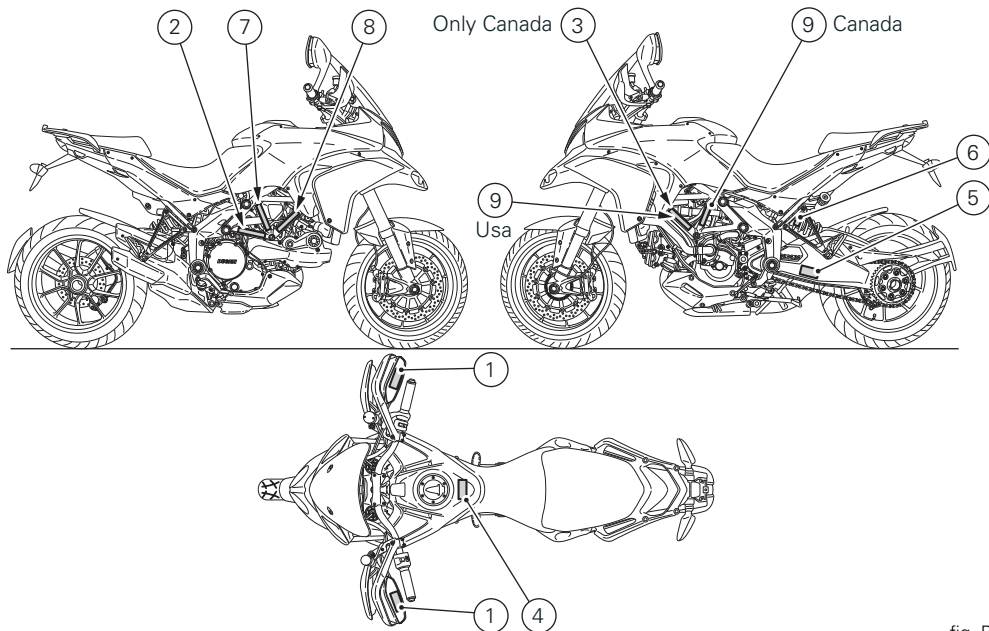

fig. B

**WARNING**

DO NOT ATTEMPT TO LOOK THROUGH THIS FAIRING. THIS IS NOT A WINDSHIELD, BUT AN AERODYNAMIC FAIRING ONLY. FAILURE TO OBSERVE THIS WARNING COULD RESULT IN A COLLISION OR UPSET AND CONSEQUENT SERIOUS BODILY INJURY. (04A-001-001-1)

1

MANUFACTURED BY / FABRIQUÉ PAR : **DUCATI**MOTORHOLDING spa  
TYPE OF VEHICLE / TYPE DE VÉHICULE : MC DATE : \*\*/\*\*\*\*

GWR / PNWB \*\*\* KG. VIN / N.L.V. : ZDM \*\*\*\*\*

GARR / PNEU KG	TRIPLO / TRIPLOXEN / TRIPLOXITE	GOLDENL PRESS. PIRELLA GOMM. A FRODO PIRELLIC SPA
***	*****	***
***	*****	***

THIS VEHICLE CONFORMS TO ALL APPLICABLE STANDARDS PRESCRIBED UNDER THE CANADIAN MOTOR VEHICLE SAFETY REGULATIONS IN EFFECT ON THE DATE OF MANUFACTURE.  
CE VÉHICULE EST CONFORME À TOUTES LES NORMES EN VIGUEUR APPLICABLES EN VERTU DU RÈGLEMENT SUR LA SÉCURITÉ DES VÉHICULES AUTOMOBILES DU CANADA EN VIGUEUR À LA DATE DE SA FABRICATION. \*\*\* \*\*

3 (Only Canada)

Tensione catena (sul cavalletto laterale)  
Chain Tension Adjustment (on side stand)

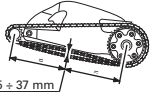

5

Manufactured by **DUCATI**MOTORHOLDING spa

DATE: ■/■/■

GWVR: ■■■ Lbs (■■■ kg)

GAWR front: ■■■ Lbs (■■■ kg) with ■■■■■ tire, ■■■■■ RIM at ■■■ PSI cold.

GAWR rear: ■■■ Lbs (■■■ kg) with ■■■■■ tire, ■■■■■ RIM at ■■■ PSI cold.

This vehicle conforms to all applicable Federal Motor Vehicle Safety standards in effect on the date of manufacture shown above. Type classification: Motorcycle

Vehicle I.D. No.: ■■■■■■■■■■

04A01120-1A

2

**CAUTION**

NEVER FILL TANK SO FUEL LEVEL RISES INTO FILLER NECK. IF TANK IS OVERFILLED, HEAT MAY CAUSE FUEL TO EXPAND AND FLOW INTO EVAPORATIVE EMISSION CONTROL SYSTEM RESULTING IN HARD STARTING AND ENGINE HESITATION.

4

**WARNING**

CONTAINS HIGHLY COMPRESSED GAS. USE ONLY PERFECTLY DRY NITROGEN GAS. OTHER GASES MAY CAUSE EXPLOSION. DO NOT INCINERATE, REFER TO OWNER'S MANUAL FOR REGULATING GAS.

6

**VEHICLE EMISSION CONTROL LABEL**

ENGINE DISPLACEMENT: 1190 cc ENGINE FAMILY: ADUC0102015  
THIS VEHICLE CONFORMS TO U.S. EPA AND CALIFORNIA REGULATIONS APPLICABLE TO 2010 MODEL YEAR NEW MOTORCYCLES.  
EVAP FAMILY: ADUC00618234



04A01120-1A

7

**VEHICLE EMISSION CONTROL INFORMATION**

ENGINE DISPLACEMENT: xxxxx

ENGINE FAMILY: xxxxxxxxxxxxxxx

ENGINE EXHAUST CONTROL SYSTEM:  
xxxxxxxxxx AND x xxxxx

EVAP FAMILY: xxxxxxxxxxxxxxx

PERMEATION FAMILY: xxxxxxxxxxxxx

THIS VEHICLE CONFORMS TO U.S., EPA AND CALIFORNIA REGULATIONS APPLICABLE TO xxxxx MODEL YEAR NEW MOTORCYCLES AND IS CERTIFIED TO xx HC+NOx G/KM ENGINE FAMILY EXHAUST EMISSION STANDARD IN CALIFORNIA.

**ENGINE TUNEUP SPECIFICATIONS**

ITEM	SPECIFICATIONS	INSTRUCTIONS
IGNITION TIMING: xx° BTDC AT IDLE SPEED		NON-ADJUSTABLE
IDLE SPEED (RPM)	xxx ± xxx	NON-ADJUSTABLE
IDLE MIXTURE		NON-ADJUSTABLE

VALVE CLEARANCE (IN & EX):  
OPENING xxxxx xxxxx mm OIL : xxxxxxxxxxxxxxxxxxx  
CLOSING xxxxxxxxxxx mm FUEL : UNLEADED GASOLINE  
SEE SERVICE MANUAL

SPARK PLUG : xxxxxxxxxxxxxxxxxxxxxxxxxxx  
GAP (mm) : xx x xx

**DUCATI**MOTORHOLDING spa - Bologna - ITALY  
Importer: **DUCATI** North America Inc. - Cupertino - California

04A01120-1A

**MOTORCYCLE NOISE EMISSION CONTROL INFORMATION**

THIS ■■■■■ MOTORCYCLE, ■■■■■■ MEETS EPA NOISE EMISSION REQUIREMENTS OF ■■ dBA AT ■■■ RPM BY THE FEDERAL TEST PROCEDURE. MODIFICATIONS WHICH CAUSE THIS MOTORCYCLE TO EXCEED FEDERAL NOISE STANDARDS ARE PROHIBITED BY FEDERAL LAW. SEE OWNER'S MANUAL.

04A 001-001-1A

8

9

## California emission control warranty statement

### Your warranty rights and obligations

The California Air Resources Board is pleased to explain the emission control system warranty on your MY 2012 motorcycle. In California, new motor vehicles must be designated, built and equipped to meet the State's stringent anti-smog standards. Ducati North America, Inc. must warrant the emission control system on your motorcycle for the periods of time listed below provided there has been no abuse, neglect or improper maintenance of your motorcycle. Your emission control system may include parts such as fuel-injection system, the ignition system, catalytic converter, and engine computer. Also included may be hoses, belts, connectors and other emission-related assemblies. Where a warrantable condition exists, Ducati North America, Inc. will repair your motorcycle at no cost to you including diagnosis, parts and labor.

## Manufacturer's warranty coverage

- 5 years or 30,000 kilometers (18641 miles), whichever first occurs.

## Owner's warranty responsibilities:

- As the motorcycle owner, you are responsible for the performance of the required maintenance listed in your owner's manual. Ducati North America, Inc. recommends that you retain all receipts covering maintenance on your motorcycle, but Ducati North America, Inc. cannot deny warranty solely for the lack of receipts or for your failure to ensure the performance of all scheduled maintenance.
- You are responsible for presenting your motorcycle to a Ducati dealer as soon as a problem exists. The warranty repairs should be completed in a reasonable amount of time, not to exceed 30 days.
- As the motorcycle owner, you should also be aware that Ducati North America, Inc. may deny you warranty coverage if your motorcycle or a part has failed due to abuse, neglect, improper maintenance or unapproved modifications.

If you have any questions regarding your warranty rights and responsibilities, you should contact Ducati North America, Inc. at 001.408.253.0499 or the California Air Resource Board at 9528 Telstar Avenue, El Monte, CA 91731.

## California evaporation emission system

This system consists of (fig. C):

- 1) Warm air inlet;
- 2) Canister;
- 3) Dell'Orto jet;
- 4) Fuel tank;
- 5) Breather pipe;
- 6) Intake manifolds.



### Important

In the event of fuel system malfunction, contact Ducati's authorized Service Centres.

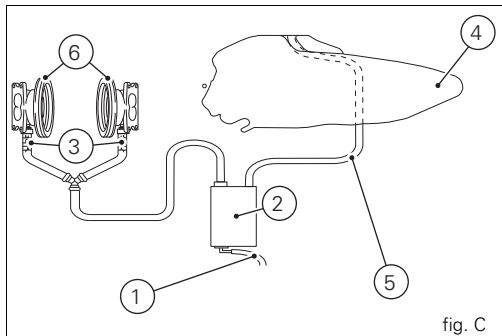

## Ducati limited warranty on emission control system

Ducati North America, Inc., 10443 Bandlely Drive Cupertino, California, 95014 warrants that each new 1998 and later Ducati motorcycle, that includes as standard equipment a headlight, tail-light and stoplight, and is street legal:

A) is designed, built and equipped so as to conform at the time of initial retail purchase with all applicable regulations of the United States Environmental Protection Agency, and the California Air Resources Board; and

B) is free from defects in material and workmanship which cause such motorcycle to fail to conform with applicable regulations of the United States Environmental Protection Agency or the California Air Resources Board for a period of use of 30,000 kilometers (18,641 miles) or 5 (five) years from the date of initial retail delivery, whichever first occurs.

### I. Coverage

Warranty defects shall be remedied during customary business hours at any authorized Ducati motorcycle dealer located within the United States of America in compliance with the Clean Air Act and applicable regulations of the United States Environmental Protection Agency and the California Air Resources Board. Any part or parts replaced under this warranty shall become the property of Ducati.



In the state of California only, emissions related warranted parts are specifically defined by that state's Emissions Warranty Parts List. These warranted parts are: carburetor and internal parts; intake manifold; fuel tank, fuel injection system; spark advance mechanism; crankcase breather; air cutoff valves; fuel tank cap for evaporative emission controlled vehicles; oil filler cap; pressure control valve; fuel/vapor separator; canister; igniters; breaker governors; ignition coils; ignition wires; ignition points, condensers, and spark plugs if failure occurs prior to the first scheduled replacement, and hoses, clamps, fittings and tubing used directly in these parts. Since emission related parts may vary from model to model, certain models may not contain all of these parts and certain models may contain functionally equivalent parts.

In the state of California only, Emission Control System emergency repairs, as provided for in the California Administrative Code, may be performed by other than an authorized Ducati dealer. An emergency situation occurs when an authorized Ducati dealer is not reasonably available, a part is not available within 30 days, or a repair is not complete within 30 days. Any replacement part can be used in an emergency repair. Ducati will reimburse the owner for the expenses, including diagnosis, not to exceed Ducati's suggested retail price for all warranted parts replaced and labor charges based on Ducati's recommended time allowance for the warranty repair and the geographically appropriate hourly labor rate. The owner may be required to keep receipts and failed parts in order to receive compensation.

## II. Limitations

This Emission Control System Warranty shall not cover any of the following:

- A. Repair or replacement required as a result of
  - (1) accident,
  - (2) misuse,
  - (3) repairs improperly performed or replacements improperly installed,
  - (4) use of replacement parts or accessories not conforming to Ducati specifications which adversely affect performance and/or
  - (5) use in competitive racing or related events.
- B. Inspections, replacement of parts and other services and adjustments required for routine maintenance.
- C. Any motorcycle on which odometer mileage has been changed so that actual mileage cannot be readily determined.

## III. Limited liability

- A. The liability of Ducati under this Emission Control Systems Warranty is limited solely to the remedying of defects in material or workmanship by an authorized Ducati motorcycle dealer at its place of business during customary business hours. This warranty does not cover inconvenience or loss of use of the motorcycle or transportation of the motorcycle to or from the Ducati dealer. Ducati shall not be liable for any other expenses, loss or damage, whether direct, incidental, consequential or exemplary arising in connection with the sale or use of or inability to use the Ducati motorcycle for any purpose. Some states do not allow the exclusion or limitation

of any incidental or consequential damages, so the above limitations may not apply to you.

B. No express emission control system warranty is given by Ducati except as specifically set forth herein. Any emission control system warranty implied by law, including any warranty of merchantability or fitness for a particular purpose, is limited to the express emission control systems warranty terms stated in this warranty. The foregoing statements of warranty are exclusive and in lieu of all other remedies. Some states do not allow limitations on how long an implied warranty lasts so the above limitation may not apply to you.

C. No dealer is authorized to modify this Ducati Limited Emission Control Systems Warranty.

#### IV. Legal rights

This warranty gives you specific legal rights, and you may also have other rights which vary from state to state.

V. This warranty is in addition to the Ducati limited motorcycle warranty.

#### VI. Additional information

Any replacement part that is equivalent in performance and durability may be used in the performance of any maintenance or repairs. However, Ducati is not liable for these parts. The owner is responsible for the performance of all required maintenance. Such maintenance may be performed at a service establishment or by any individual. The warranty period begins on the date the motorcycle is delivered to an ultimate purchaser.

Ducati North America, Inc..  
10443 Bandlely Drive  
Cupertino, California, 95014  
Tel: 001.408.253.0499  
Fax: 001.408.253.4099  
E-mail: [customerservice@ducatiusa.com](mailto:customerservice@ducatiusa.com)  
Web site: [www.ducatiusa.com](http://www.ducatiusa.com)

## Routine maintenance record

KM	MI	DUCATI SERVICE NAME	MILEAGE	DATE
1,000	600			
12,000	7,500			
24,000	15,000			
36,000	22,500			
48,000	30,000			
60,000	37,500			

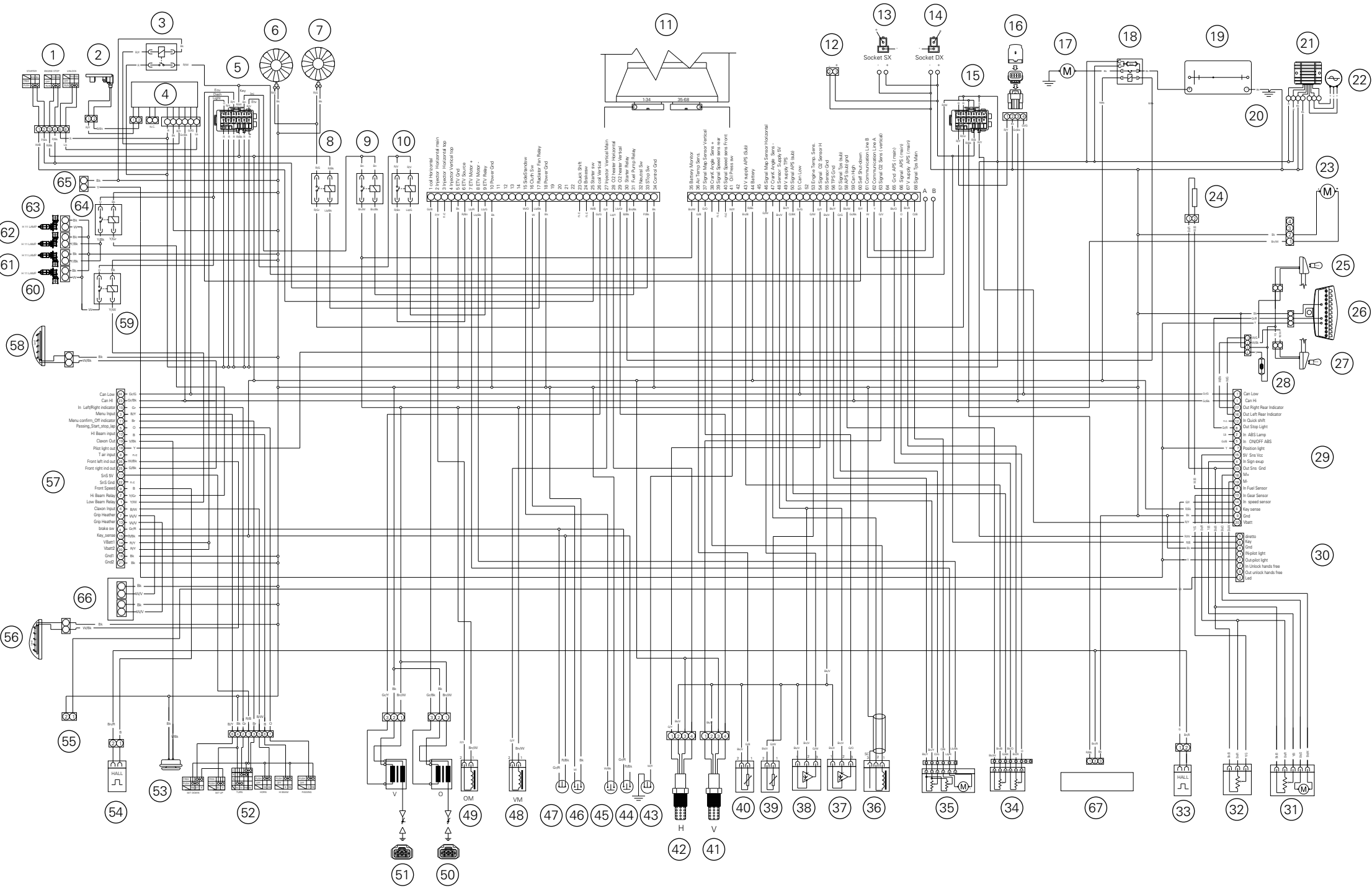

Multistrada 1200

Stampato 11/2011

Cod. 913.7.176.1M

Ducati Motor Holding spa  
[www.ducati.com](http://www.ducati.com)

Via Cavalieri Ducati, 3  
40132 Bologna, Italia  
Tel. +39 051 6413111  
Fax +39 051 406580

cod 913.7.176.1M