



⚠ Read this manual carefully before operating this vehicle.

OWNER'S MANUAL

**Vmax**

**VMX17**

**2CE-28199-E1**

 **Read this manual carefully before operating this vehicle. This manual should stay with this vehicle if it is sold.**



YAMAHA MOTOR ELECTRONICS CO., LTD.

1450-6, Mori, Mori-machi, Shuchi-gun, Shizuoka-ken, 437-0292 Japan

## DECLARATION of CONFORMITY

For



Product: IMMOBILIZER  
Model: 2S3-00

### Supplied by

YAMAHA MOTOR ELECTRONICS  
CO.,LTD.  
1450-6 Mori, Mori-machi Shuchi-gun  
Shizuoka 437-0292 Japan

### Technical Construction File held by

YAMAHA MOTOR ELECTRONICS  
CO.,LTD.  
1450-6 Mori, Mori-machi Shuchi-gun  
Shizuoka 437-0292 Japan

### Standard used for comply

**R&TTE Directive**  
**(Article 3.1(a) Safety)**  
EN 60950-1: 2006 + Amd.11:2009 + Amd.1:2010 +  
Amd.12: 2011  
EN 62479: 2010

**R&TTE Directive**  
**(Article 3.1(b) EMC)**  
97/24/EC from 17.06.1997

**R&TTE Directive**  
**(Article 3.2 Spectrum)**  
EN 300 330-1 V1.7.1: 2010  
EN 300 330-2 V1.5.1: 2010

### Means of Conformity

We declare under our sole responsibility that the Product (s) is conformity with the essential requirements and other relevant requirements of the  
Radio and Telecommunication Terminal Equipment (R&TTE) Directive (1999/5/EC).

**Date of issue:** January 12, 2015

### Signature of Responsible Person:



Kazuhide Takasugi  
GENERAL MANAGER  
QUALITY ASSURANCE DIV.

Welcome to the Yamaha world of motorcycling!

As the owner of the VMX17, you are benefiting from Yamaha's vast experience and newest technology regarding the design and manufacture of high-quality products, which have earned Yamaha a reputation for dependability.

Please take the time to read this manual thoroughly, so as to enjoy all advantages of your VMX17. The Owner's Manual does not only instruct you in how to operate, inspect and maintain your motorcycle, but also in how to safeguard yourself and others from trouble and injury.

In addition, the many tips given in this manual will help keep your motorcycle in the best possible condition. If you have any further questions, do not hesitate to contact your Yamaha dealer.

The Yamaha team wishes you many safe and pleasant rides. So, remember to put safety first!

Yamaha continually seeks advancements in product design and quality. Therefore, while this manual contains the most current product information available at the time of printing, there may be minor discrepancies between your motorcycle and this manual. If there is any question concerning this manual, please consult a Yamaha dealer.



---

**Please read this manual carefully and completely before operating this motorcycle.**



---

# Important manual information

---

EAU10134

Particularly important information is distinguished in this manual by the following notations:

	<b>This is the safety alert symbol. It is used to alert you to potential personal injury hazards. Obey all safety messages that follow this symbol to avoid possible injury or death.</b>
 <b>WARNING</b>	<b>A WARNING indicates a hazardous situation which, if not avoided, could result in death or serious injury.</b>
<b>NOTICE</b>	<b>A NOTICE indicates special precautions that must be taken to avoid damage to the vehicle or other property.</b>
<b>TIP</b>	A TIP provides key information to make procedures easier or clearer.

\*Product and specifications are subject to change without notice.

EAU10201

**VMX17  
OWNER'S MANUAL  
©2015 by Yamaha Motor Co., Ltd.  
1st edition, October 2015  
All rights reserved.  
Any reprinting or unauthorized use  
without the written permission of  
Yamaha Motor Co., Ltd.  
is expressly prohibited.  
Printed in Japan.**

# Table of contents

---

<b>Safety information</b> .....	1-1	Sidestand.....	3-31	Checking the throttle grip free	
<b>Description</b> .....	2-1	Ignition circuit cut-off system .....	3-32	play.....	6-20
Left view .....	2-1	<b>For your safety – pre-operation</b>		Valve clearance.....	6-20
Right view.....	2-2	<b>checks</b> .....	4-1	Tires.....	6-21
Controls and instruments.....	2-3	<b>Operation and important riding</b>		Cast wheels.....	6-23
<b>Instrument and control functions</b> ...	3-1	<b>points</b> .....	5-1	Clutch lever.....	6-23
Immobilizer system.....	3-1	Starting the engine.....	5-1	Checking the brake lever free	
Main switch/steering lock.....	3-2	Shifting .....	5-2	play.....	6-24
Indicator lights and warning		Tips for reducing fuel		Brake light switches .....	6-24
lights.....	3-4	consumption.....	5-3	Checking the front and rear	
Speedometer unit.....	3-7	Engine break-in.....	5-3	brake pads .....	6-25
Multi-function display .....	3-8	Parking .....	5-4	Checking the brake fluid level .....	6-25
Handlebar switches.....	3-17	<b>Periodic maintenance and</b>		Changing the brake and clutch	
Clutch lever .....	3-18	<b>adjustment</b> .....	6-1	fluids.....	6-27
Shift pedal .....	3-19	Owner’s tool kits .....	6-2	Checking and lubricating the	
Brake lever.....	3-19	Periodic maintenance chart for the		cables.....	6-27
Brake pedal .....	3-20	emission control system.....	6-3	Checking and lubricating the	
ABS .....	3-20	General maintenance and		brake and shift pedals.....	6-28
Fuel tank cap.....	3-21	lubrication chart.....	6-4	Checking and lubricating the	
Fuel.....	3-22	Removing and installing the		brake and clutch levers.....	6-28
Fuel tank breather hose and		cowling and panels.....	6-8	Checking and lubricating the	
overflow hose.....	3-24	Checking the spark plugs .....	6-10	sidestand.....	6-29
Catalytic converters .....	3-24	Engine oil and oil filter cartridge....	6-11	Lubricating the swingarm	
Seats .....	3-25	Final gear oil.....	6-14	pivots.....	6-29
Adjusting the front fork.....	3-26	Coolant.....	6-16	Checking the front fork.....	6-30
Adjusting the shock absorber		Air filter element .....	6-19	Checking the steering.....	6-30
assembly.....	3-28	Checking the engine idling		Checking the wheel bearings .....	6-31
Luggage strap holders .....	3-30	speed.....	6-20	Battery .....	6-31
EXUP system.....	3-31			Replacing the fuses .....	6-34

# Table of contents

---

- Replacing the headlight bulb.....6-35
- Replacing the auxiliary light
  - bulb .....6-37
- Brake/tail light .....6-37
- Replacing a turn signal light
  - bulb .....6-38
- Replacing a license plate light
  - bulb .....6-38
- Supporting the motorcycle.....6-39
- Troubleshooting .....6-40
- Troubleshooting charts .....6-41
  
- Motorcycle care and storage .....7-1**
  - Matte color caution .....7-1
  - Care.....7-1
  - Storage.....7-4
  
- Specifications.....8-1**
  
- Consumer information .....9-1**
  - Identification numbers.....9-1
  
- Index .....10-1**

## Be a Responsible Owner

As the vehicle's owner, you are responsible for the safe and proper operation of your motorcycle.

Motorcycles are single-track vehicles. Their safe use and operation are dependent upon the use of proper riding techniques as well as the expertise of the operator. Every operator should know the following requirements before riding this motorcycle.

He or she should:

- Obtain thorough instructions from a competent source on all aspects of motorcycle operation.
- Observe the warnings and maintenance requirements in this Owner's Manual.
- Obtain qualified training in safe and proper riding techniques.
- Obtain professional technical service as indicated in this Owner's Manual and/or when made necessary by mechanical conditions.

- Never operate a motorcycle without proper training or instruction. Take a training course. Beginners should receive training from a certified instructor. Contact an authorized motorcycle dealer to find out about the training courses nearest you.

## Safe Riding

Perform the pre-operation checks each time you use the vehicle to make sure it is in safe operating condition. Failure to inspect or maintain the vehicle properly increases the possibility of an accident or equipment damage. See page 4-1 for a list of pre-operation checks.

- This motorcycle is designed to carry the operator and a passenger.
- The failure of motorists to detect and recognize motorcycles in traffic is the predominating cause of automobile/motorcycle accidents. Many accidents have been caused by an automobile driver who did not see the motorcycle. Making yourself conspicuous ap-

pears to be very effective in reducing the chance of this type of accident.

### Therefore:

- Wear a brightly colored jacket.
- Use extra caution when you are approaching and passing through intersections, since intersections are the most likely places for motorcycle accidents to occur.
- Ride where other motorists can see you. Avoid riding in another motorist's blind spot.
- Never maintain a motorcycle without proper knowledge. Contact an authorized motorcycle dealer to inform you on basic motorcycle maintenance. Certain maintenance can only be carried out by certified staff.



- Many accidents involve inexperienced operators. In fact, many operators who have been involved in accidents do not even have a current motorcycle license.
  - Make sure that you are qualified and that you only lend your motorcycle to other qualified operators.
  - Know your skills and limits. Staying within your limits may help you to avoid an accident.
  - We recommend that you practice riding your motorcycle where there is no traffic until you have become thoroughly familiar with the motorcycle and all of its controls.
- Many accidents have been caused by error of the motorcycle operator. A typical error made by the operator is veering wide on a turn due to excessive speed or undercornering (insufficient lean angle for the speed).
  - Always obey the speed limit and never travel faster than warranted by road and traffic conditions.
  - Always signal before turning or changing lanes. Make sure that other motorists can see you.
- The posture of the operator and passenger is important for proper control.
  - The operator should keep both hands on the handlebar and both feet on the operator footrests during operation to maintain control of the motorcycle.
  - The passenger should always hold onto the operator, the seat strap or grab bar, if equipped, with both hands and keep both feet on the passenger footrests. Never carry a passenger unless he or she can firmly place both feet on the passenger footrests.
- Never ride under the influence of alcohol or other drugs.
- This motorcycle is designed for on-road use only. It is not suitable for off-road use.

### **Protective Apparel**

The majority of fatalities from motorcycle accidents are the result of head injuries. The use of a safety helmet is the single most critical factor in the prevention or reduction of head injuries.

- Always wear an approved helmet.
- Wear a face shield or goggles. Wind in your unprotected eyes could contribute to an impairment of vision that could delay seeing a hazard.
- The use of a jacket, heavy boots, trousers, gloves, etc., is effective in preventing or reducing abrasions or lacerations.
- Never wear loose-fitting clothes, otherwise they could catch on the control levers, footrests, or wheels and cause injury or an accident.
- Always wear protective clothing that covers your legs, ankles, and feet. The engine or exhaust system become very hot during or after operation and can cause burns.
- A passenger should also observe the above precautions.

# Safety information

1

## Avoid Carbon Monoxide Poisoning

All engine exhaust contains carbon monoxide, a deadly gas. Breathing carbon monoxide can cause headaches, dizziness, drowsiness, nausea, confusion, and eventually death.

Carbon Monoxide is a colorless, odorless, tasteless gas which may be present even if you do not see or smell any engine exhaust. Deadly levels of carbon monoxide can collect rapidly and you can quickly be overcome and unable to save yourself. Also, deadly levels of carbon monoxide can linger for hours or days in enclosed or poorly ventilated areas. If you experience any symptoms of carbon monoxide poisoning, leave the area immediately, get fresh air, and SEEK MEDICAL TREATMENT.

- Do not run engine indoors. Even if you try to ventilate engine exhaust with fans or open windows and doors, carbon monoxide can rapidly reach dangerous levels.
- Do not run engine in poorly ventilated or partially enclosed areas such as barns, garages, or carports.

- Do not run engine outdoors where engine exhaust can be drawn into a building through openings such as windows and doors.

## Loading

Adding accessories or cargo to your motorcycle can adversely affect stability and handling if the weight distribution of the motorcycle is changed. To avoid the possibility of an accident, use extreme caution when adding cargo or accessories to your motorcycle. Use extra care when riding a motorcycle that has added cargo or accessories. Here, along with the information about accessories below, are some general guidelines to follow if loading cargo to your motorcycle:

The total weight of the operator, passenger, accessories and cargo must not exceed the maximum load limit.

**Operation of an overloaded vehicle could cause an accident.**

**Maximum load:**  
190 kg (419 lb)

When loading within this weight limit, keep the following in mind:

- Cargo and accessory weight should be kept as low and close to the motorcycle as possible. Securely pack your heaviest items as close to the center of the vehicle as possible and make sure to distribute the weight as evenly as possible on both sides of the motorcycle to minimize imbalance or instability.
- Shifting weights can create a sudden imbalance. Make sure that accessories and cargo are securely attached to the motorcycle before riding. Check accessory mounts and cargo restraints frequently.
- Properly adjust the suspension for your load (suspension-adjustable models only), and check the condition and pressure of your tires.
- Never attach any large or heavy items to the handlebar, front fork, or front fender. These items, including such cargo as sleeping bags, duffel bags, or

tents, can create unstable handling or a slow steering response.

- **This vehicle is not designed to pull a trailer or to be attached to a sidecar.**

### **Genuine Yamaha Accessories**

Choosing accessories for your vehicle is an important decision. Genuine Yamaha accessories, which are available only from a Yamaha dealer, have been designed, tested, and approved by Yamaha for use on your vehicle.

Many companies with no connection to Yamaha manufacture parts and accessories or offer other modifications for Yamaha vehicles. Yamaha is not in a position to test the products that these aftermarket companies produce. Therefore, Yamaha can neither endorse nor recommend the use of accessories not sold by Yamaha or modifications not specifically recommended by Yamaha, even if sold and installed by a Yamaha dealer.

### **Aftermarket Parts, Accessories, and Modifications**

While you may find aftermarket products similar in design and quality to genuine Yamaha accessories, recognize that some aftermarket accessories or modifications are not suitable because of potential safety hazards to you or others. Installing aftermarket products or having other modifications performed to your vehicle that change any of the vehicle's design or operation characteristics can put you and others at greater risk of serious injury or death. You are responsible for injuries related to changes in the vehicle.

Keep the following guidelines in mind, as well as those provided under "Loading" when mounting accessories.

- Never install accessories or carry cargo that would impair the performance of your motorcycle. Carefully inspect the accessory before using it to make sure that it does not in any way reduce ground clearance or cornering clearance, limit suspension travel,

steering travel or control operation, or obscure lights or reflectors.

- Accessories fitted to the handlebar or the front fork area can create instability due to improper weight distribution or aerodynamic changes. If accessories are added to the handlebar or front fork area, they must be as lightweight as possible and should be kept to a minimum.
- Bulky or large accessories may seriously affect the stability of the motorcycle due to aerodynamic effects. Wind may attempt to lift the motorcycle, or the motorcycle may become unstable in cross winds. These accessories may also cause instability when passing or being passed by large vehicles.
- Certain accessories can displace the operator from his or her normal riding position. This improper position limits the freedom of movement of the

# Safety information

---

1

operator and may limit control ability, therefore, such accessories are not recommended.

- Use caution when adding electrical accessories. If electrical accessories exceed the capacity of the motorcycle's electrical system, an electric failure could result, which could cause a dangerous loss of lights or engine power.

## **Aftermarket Tires and Rims**

The tires and rims that came with your motorcycle were designed to match the performance capabilities and to provide the best combination of handling, braking, and comfort. Other tires, rims, sizes, and combinations may not be appropriate. Refer to page 6-21 for tire specifications and more information on replacing your tires.

## **Transporting the Motorcycle**

Be sure to observe following instructions before transporting the motorcycle in another vehicle.

- Remove all loose items from the motorcycle.

- Check that the fuel cock (if equipped) is in the "OFF" position and that there are no fuel leaks.
- Point the front wheel straight ahead on the trailer or in the truck bed, and choke it in a rail to prevent movement.
- Shift the transmission in gear (for models with a manual transmission).
- Secure the motorcycle with tie-downs or suitable straps that are attached to solid parts of the motorcycle, such as the frame or upper front fork triple clamp (and not, for example, to rubber-mounted handlebars or turn signals, or parts that could break). Choose the location for the straps carefully so the straps will not rub against painted surfaces during transport.
- The suspension should be compressed somewhat by the tie-downs, if possible, so that the motorcycle will not bounce excessively during transport.

## Left view

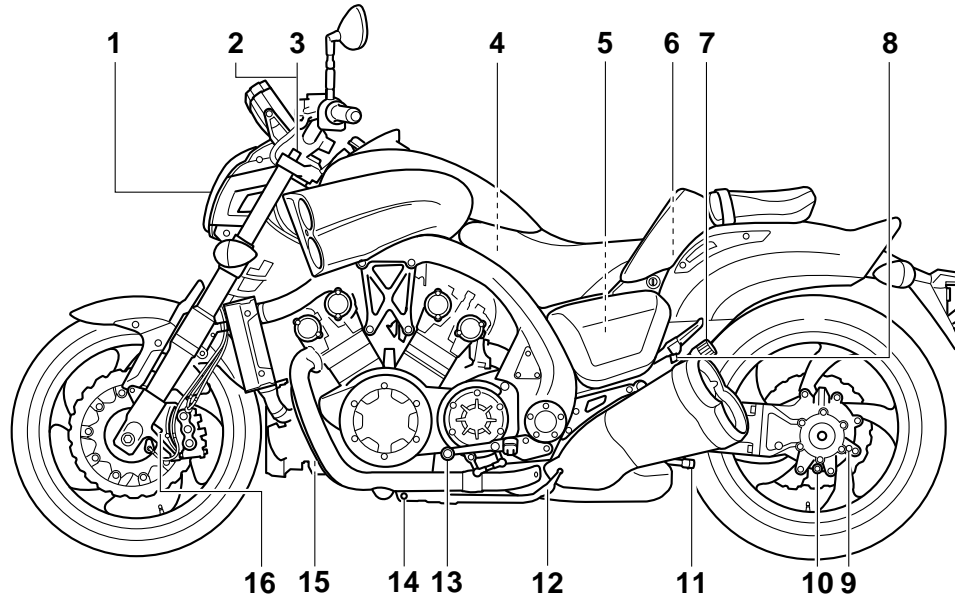

1. Headlight (page 6-35)
2. Front fork spring preload adjusting bolt (page 3-26)
3. Front fork rebound damping force adjusting knob (page 3-26)
4. Battery (page 6-31)
5. Owner's tool kit (page 6-2)
6. Fuel tank cap (page 3-21)
7. Shock absorber assembly spring preload adjusting knob (page 3-28)
8. Luggage strap holder (page 3-30)
9. Final gear oil check bolt (page 6-14)
10. Final gear oil drain bolt (page 6-14)
11. Shock absorber assembly rebound damping force adjusting knob (page 3-28)
12. Sidestand (page 3-31)
13. Shift pedal (page 3-19)
14. Engine oil drain bolt (page 6-11)
15. Engine oil filter cartridge (page 6-11)
16. Front fork compression damping force adjusting screw (page 3-26)

# Description

EAU10421

## Right view

2

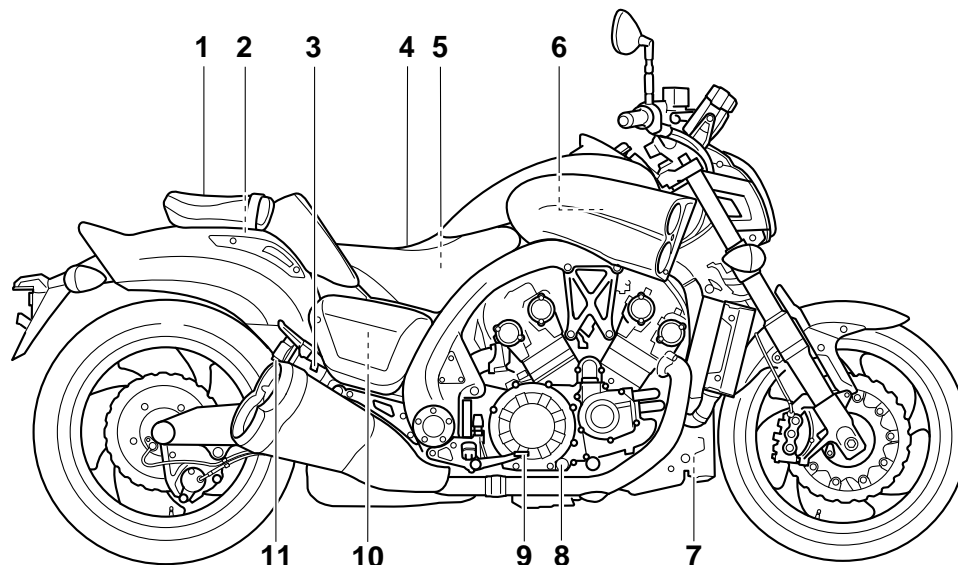

1. Passenger seat (page 3-25)

2. Rear brake fluid reservoir (page 6-25)

3. Luggage strap holder (page 3-30)

4. Rider seat (page 3-25)

5. Fuse box 1 (page 6-34)

6. Radiator cap (page 6-16)

7. Coolant reservoir (page 6-16)

8. Engine oil level check window (page 6-11)

9. Brake pedal (page 3-20)

10. Fuse box 2 (page 6-34)

11. Shock absorber assembly compression damping force adjusting knob (page 3-28)

## Controls and instruments

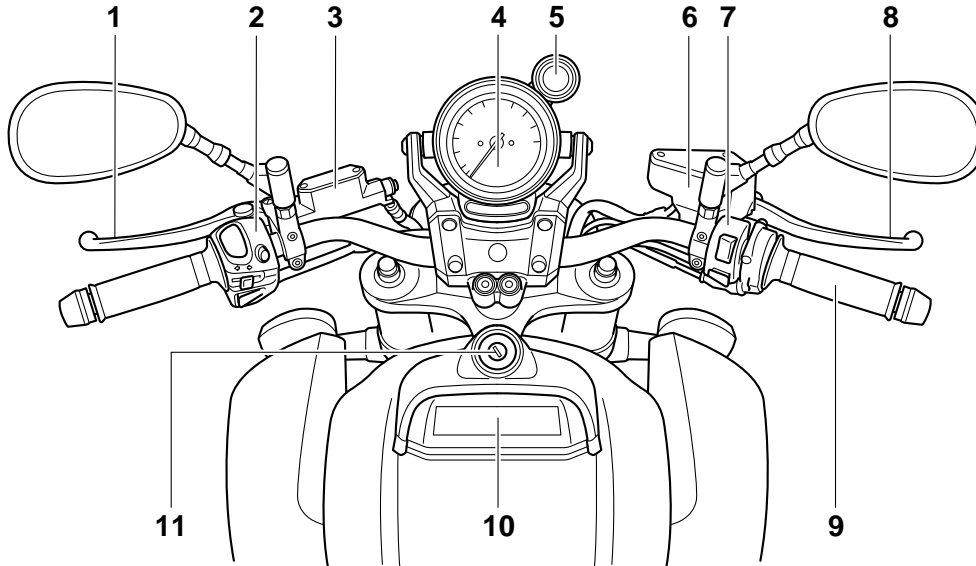

- 1. Clutch lever (page 3-18)
- 2. Left handlebar switches (page 3-17)
- 3. Clutch fluid reservoir (page 6-27)
- 4. Speedometer unit (page 3-7)
- 5. Shift timing indicator light (page 3-6)
- 6. Front brake fluid reservoir (page 6-25)
- 7. Right handlebar switches (page 3-17)
- 8. Brake lever (page 3-19)

- 9. Throttle grip (page 6-20)
- 10. Multi-function display (page 3-8)
- 11. Main switch/steering lock (page 3-2)

# Instrument and control functions

## Immobilizer system

EAU10978

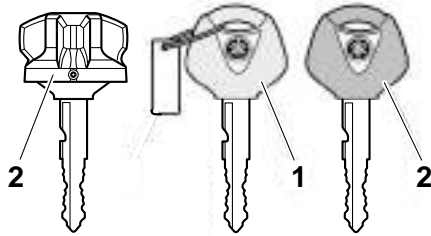

1. Code re-registering key (red bow)
2. Standard keys (black bow)

This vehicle is equipped with an immobilizer system to help prevent theft by re-registering codes in the standard keys. This system consists of the following:

- a code re-registering key (with a red bow)
- two standard keys (with a black bow) that can be re-registered with new codes
- a transponder (which is installed in the code re-registering key)
- an immobilizer unit
- an ECU

- an immobilizer system indicator light (See page 3-6.)

The key with the red bow is used to register codes in each standard key. Since re-registering is a difficult process, take the vehicle along with all three keys to a Yamaha dealer to have them re-registered. Do not use the key with the red bow for driving. It should only be used for re-registering the standard keys. Always use a standard key for driving.

ECA11822

### NOTICE

- **DO NOT LOSE THE CODE RE-REGISTERING KEY! CONTACT YOUR DEALER IMMEDIATELY IF IT IS LOST!** If the code re-registering key is lost, registering new codes in the standard keys is impossible. The standard keys can still be used to start the vehicle, however if code re-registering is required (i.e., if a new standard key is made or all keys are lost) the entire immobilizer system must be replaced. Therefore, it is highly recom-

mended to use either standard key and keep the code re-registering key in a safe place.

- Do not submerge any key in water.
- Do not expose any key to excessively high temperatures.
- Do not place any key close to magnets (this includes, but not limited to, products such as speakers, etc.).
- Do not place items that transmit electrical signals close to any key.
- Do not place heavy items on any key.
- Do not grind any key or alter its shape.
- Do not disassemble the plastic part of any key.
- Do not put two keys of any immobilizer system on the same key ring.
- Keep the standard keys as well as keys of other immobilizer systems away from this vehicle's code re-registering key.



- Keep other immobilizer system keys away from the main switch as they may cause signal interference.

## Main switch/steering lock

EAU10474

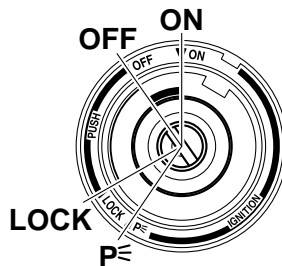

The main switch/steering lock controls the ignition and lighting systems, and is used to lock the steering. The various positions are described below.

### TIP

Be sure to use the standard key (black bow) for regular use of the vehicle. To minimize the risk of losing the code re-registering key (red bow), keep it in a safe place and only use it for code re-registering.

### ON

All electrical circuits are supplied with power; the meter lighting, taillight, license plate light and auxiliary light come on, and the engine can be started. The key cannot be removed.

### TIP

The headlight comes on automatically when the engine is started and stays on until the key is turned to “OFF”, even if the engine stalls.

### OFF

All electrical systems are off. The key can be removed.

### **⚠ WARNING**

**Never turn the key to “OFF” or “LOCK” while the vehicle is moving. Otherwise the electrical systems will be switched off, which may result in loss of control or an accident.**

EAU38531

EAU10662

EWA10062

# Instrument and control functions

## LOCK

EAU10687

The steering is locked and all electrical systems are off. The key can be removed.

3

### To lock the steering

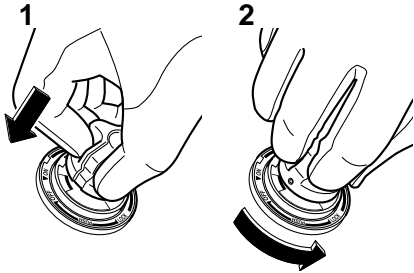

1. Push.
2. Turn.

1. Turn the handlebars all the way to the left.
2. With the key in the “OFF” position, push the key in and turn it to “LOCK”.
3. Remove the key.

## TIP

If the steering will not lock, try turning the handlebars back to the right slightly.

### To unlock the steering

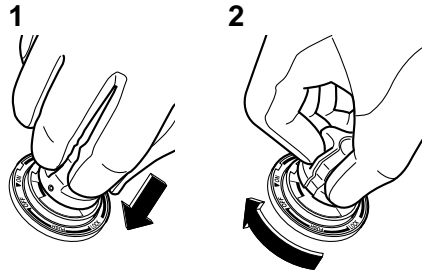

1. Push.
2. Turn.

1. Insert the key.
2. With the key in the “LOCK” position, push the key in and turn it to “OFF”.

## p⊂ (Parking)

EAU34342

The steering is locked, and the taillight, license plate light and auxiliary light are on. The hazard lights and turn signal

lights can be turned on, but all other electrical systems are off. The key can be removed.

The steering must be locked before the key can be turned to “p⊂”.

ECA11021

## NOTICE

**Do not use the parking position for an extended length of time, otherwise the battery may discharge.**

## Indicator lights and warning lights

EAU49398

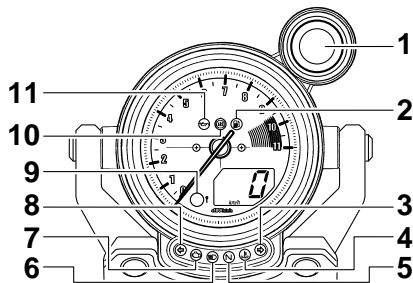

1. Shift timing indicator light
2. Fuel level warning light “”
3. Right turn signal indicator light “”
4. Coolant temperature warning light “”
5. Neutral indicator light “**N**”
6. High beam indicator light “”
7. Engine trouble warning light “”
8. Left turn signal indicator light “”
9. Immobilizer system indicator light
10. Anti-lock Brake System (ABS) warning light “”
11. Oil level warning light “”

### Turn signal indicator lights “” and “”

EAU11032

Each indicator light will flash when its corresponding turn signal lights are flashing.

### Neutral indicator light “**N**”

EAU11061

This indicator light comes on when the transmission is in the neutral position.

### High beam indicator light “”

EAU11081

This indicator light comes on when the high beam of the headlight is switched on.

### Oil level warning light “”

EAU46567

This warning light comes on if the engine oil level is low.

To check the electrical circuit of the warning light, place the vehicle on a level surface, set the engine stop switch to “” and turn the key from “OFF” to “ON”.

If the warning light does not come on for a few seconds and then go off, have a Yamaha dealer check the vehicle.

If the warning light stays on, proceed as follows.

1. Set the engine stop switch to “”.
2. Turn the key to “OFF”, wait two minutes, and then turn the key to “ON”.
3. If the warning light comes on and does not go off, check the engine oil level. (See page 6-11.) If the warning light still stays on after confirming the oil level is correct, have a Yamaha dealer check the vehicle.

### TIP

- This warning light will not come on:
  - when the engine is idling
  - when riding
  - if the engine has stalled and the key has not been turned from “ON” to “OFF” and then back to “ON”

However, if the warning light is on when the engine is started, it will stay on until the key is turned to “OFF”.

# Instrument and control functions

3

- This model is equipped with a self-diagnosis device for the oil level detection circuit. If a problem is detected in the oil level detection circuit, the oil level warning light will flash repeatedly. If this occurs, have a Yamaha dealer check the vehicle.

EAU48702

## Fuel level warning light “”

This warning light comes on when the fuel level drops below approximately 3.9 L (1.03 US gal, 0.86 Imp.gal). When this occurs, refuel as soon as possible. The electrical circuit of the warning light can be checked by turning the key to “ON”. The warning light should come on for a few seconds, and then go off.

If the warning light does not come on initially when the key is turned to “ON”, or if the warning light remains on after refueling, have a Yamaha dealer check the vehicle.

## TIP

This model is equipped with a self-diagnosis device for the fuel level detection circuit. If a problem is detected in

the fuel level detection circuit, the fuel level warning light, the fuel meter and the fuel level warning indicator will flash repeatedly. If this occurs, have a Yamaha dealer check the vehicle.

EAU11447

## Coolant temperature warning light “”

This warning light comes on if the engine overheats. If this occurs, stop the engine immediately and allow the engine to cool.

The electrical circuit of the warning light can be checked by turning the key to “ON”. The warning light should come on for a few seconds, and then go off.

If the warning light does not come on initially when the key is turned to “ON”, or if the warning light remains on, have a Yamaha dealer check the electrical circuit.

ECA10022

## NOTICE

**Do not continue to operate the engine if it is overheating.**

## TIP

- For radiator-fan-equipped vehicles, the radiator fan(s) automatically switch on or off according to the coolant temperature in the radiator.
- If the engine overheats, see page 6-42 for further instructions.

EAU46443

## Engine trouble warning light “”

This warning light comes on if a problem is detected in the electrical circuit monitoring the engine. If this occurs, have a Yamaha dealer check the self-diagnosis system. (See page 3-16 for an explanation of the self-diagnosis device.)

The electrical circuit of the warning light can be checked by turning the key to “ON”. The warning light should come on for a few seconds, and then go off.

If the warning light does not come on initially when the key is turned to “ON”, or if the warning light remains on, have a Yamaha dealer check the electrical circuit.

## TIP

This warning light will come on when the key is turned to “ON” and the start switch is pushed, but this does not indicate a malfunction.

## ABS warning light “”

EAU51662

In normal operation, the ABS warning light comes on when the key is turned to “ON”, and goes off after traveling at a speed of 10 km/h (6 mi/h) or higher.

If the ABS warning light:

- does not come on when the key is turned to “ON”
- comes on or flashes while riding
- does not go off after traveling at a speed of 10 km/h (6 mi/h) or higher

The ABS may not work correctly. If any of the above occurs, have a Yamaha dealer check the system as soon as possible. (See page 3-20 for an explanation of the ABS.)

EWA16041



**If the ABS warning light does not go off after traveling at a speed of 10 km/h (6 mi/h) or higher, or if the**

**warning light comes on or flashes while riding, the brake system reverts to conventional braking. If either of the above occurs, or if the warning light does not come on at all, use extra caution to avoid possible wheel lock during emergency braking. Have a Yamaha dealer check the brake system and electrical circuits as soon as possible.**

## TIP

If the start switch is pushed while the engine is running, the ABS warning light will come on, but this is not a malfunction.

EAU48522

## Shift timing indicator light

This indicator light can be set to come on and go off at the desired engine speeds and is used to inform the rider when it is time to shift to the next higher gear. (See “Select mode” on page 3-10 for an explanation on how to set this indicator light.)

The electrical circuit of the indicator light can be checked by turning the key to “ON”. The indicator light should come on for a few seconds, and then go off.

If the indicator light does not come on initially when the key is turned to “ON”, or if the indicator light remains on, have a Yamaha dealer check the electrical circuit.

## Immobilizer system indicator light

EAU38626

When the key is turned to “OFF” and 30 seconds have passed, the indicator light will start flashing indicating the immobilizer system is enabled. After 24 hours have passed, the indicator light will stop flashing, however the immobilizer system is still enabled.

The electrical circuit of the indicator light can be checked by turning the key to “ON”. The indicator light should come on for a few seconds, and then go off.

# Instrument and control functions

If the indicator light does not come on initially when the key is turned to “ON”, or if the indicator light remains on, have a Yamaha dealer check the electrical circuit.

3

The self-diagnosis device also detects problems in the immobilizer system circuits. (See page 3-16 for an explanation of the self-diagnosis device.)

## Speedometer unit

EAU46627

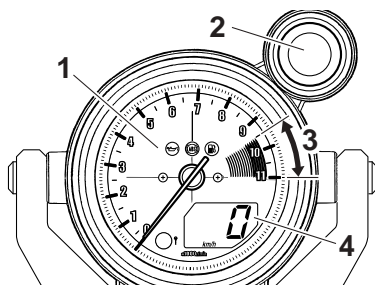

1. Tachometer
2. Shift timing indicator light
3. Tachometer red zone
4. Speedometer

## Speedometer

The speedometer shows the vehicle’s traveling speed.

### TIP \_\_\_\_\_

For the UK

The speedometer can be switched between kilometers and miles. To switch the speedometer, press the “SELECT” button for at least two seconds.

A “SELECT” button and a “RESET” button are located on the handlebar holder.

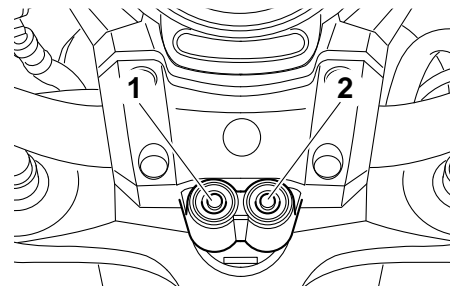

1. “SELECT” button
2. “RESET” button

## Tachometer

The tachometer allows the rider to monitor the engine speed and keep it within the ideal power range. When the key is turned to “ON”, the tachometer needle will sweep once across the r/min range and then return to zero r/min in order to test the electrical circuit.

ECA10032

### NOTICE \_\_\_\_\_

**Do not operate the engine in the tachometer red zone.**

**Red zone: 9500 r/min and above**

## Shift timing indicator light

The shift timing indicator light works with the tachometer to inform the rider of engine speed. See “Select mode” on page 3-10 for an explanation on how to set this indicator light.

## Multi-function display

EAU4658G

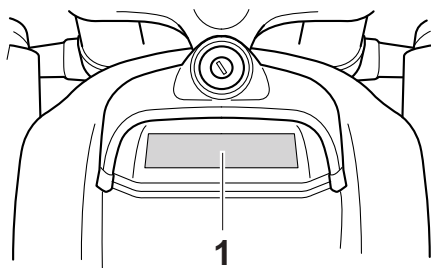

1. Multi-function display

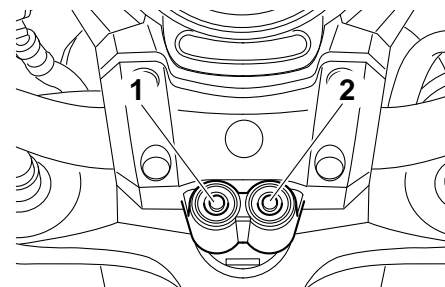

1. “SELECT” button  
2. “RESET” button

## WARNING

EWA12313

**Be sure to stop the vehicle before making any setting changes to the multi-function display. Changing settings while riding can distract the operator and increase the risk of an accident.**

A “SELECT” button and a “RESET” button are located on the handlebar holder. These buttons allow you to control or change the settings in the multi-function display.

The multi-function display is set to the Normal mode every time the key is turned to “ON”.

## Normal mode

The following functions are available in the Normal mode:

- odometer
- clock
- two tripmeters
- fuel reserve tripmeter
- fuel meter
- transmission gear indicator
- coolant temperature meter
- self-diagnosis device

# Instrument and control functions

3

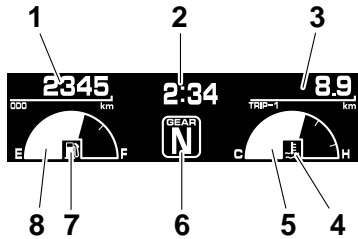

1. Odometer
2. Clock
3. Tripmeter/fuel reserve tripmeter
4. Coolant temperature warning indicator “”
5. Coolant temperature meter
6. Transmission gear indicator
7. Fuel level warning indicator “”
8. Fuel meter

The odometer shows the total distance traveled by the vehicle.

The tripmeters show the distance traveled since they were last reset.

The fuel reserve tripmeter shows the distance traveled on the fuel reserve.

The clock displays time in 12-hour format.

## TIP

- The odometer will lock at 999999.

- The tripmeters will reset and continue counting after 9999.9 is reached.
- For the UK: to switch between kilometers and miles, press “SELECT” for two seconds.

## Tripmeters

Turn the key to “ON”. Push “SELECT” to switch the display between the tripmeters “TRIP-1” and “TRIP-2” in the following order:

TRIP-1 → TRIP-2 → TRIP-1

When the fuel amount in the fuel tank decreases to 3.9 L (1.03 US gal, 0.86 Imp.gal), the fuel level warning light comes on, and the tripmeter automatically changes to the fuel reserve tripmeter “TRIP-F” and starts counting the distance traveled from that point. In that case, push “SELECT” to switch the display in the following order:

TRIP-F → TRIP-1 → TRIP-2 → TRIP-F

If you continue to ride the vehicle after the fuel reserve tripmeter “TRIP-F” appears, the fuel meter and fuel level warning indicator “” start flashing.

To reset a tripmeter, select it by pushing “SELECT”, and then push “RESET” for one second.

The fuel reserve tripmeter can be reset manually, or after refueling and traveling 5 km (3 mi), it will reset automatically and disappear from the display.

## Fuel meter

The fuel meter indicates the amount of fuel in the fuel tank. The displayed fuel level decreases from “F” (full) towards “E” (empty) as the fuel level decreases. When the amount of fuel decreases to approximately 3.9 L (1.03 US gal, 0.86 Imp.gal), the fuel level warning light comes on. If this occurs, refuel as soon as possible.

If you continue to ride the vehicle after the fuel reserve tripmeter “TRIP-F” appears, the fuel meter and the fuel level warning indicator “” start flashing.

## Transmission gear indicator

This indicator shows the selected gear. The neutral position is indicated by “N” and by the neutral indicator light.



# Instrument and control functions

## Coolant temperature meter

The coolant temperature meter indicates the temperature of the coolant. The coolant temperature varies with changes in the weather and engine load. If the coolant temperature meter and the coolant temperature warning indicator flash, stop the vehicle and let the engine cool. (See page 6-42.)

ECA10022

### NOTICE

**Do not continue to operate the engine if it is overheating.**

## Select mode

The various functions of this multi-function display are adjusted in the Select mode.

### TIP

- The transmission must be in neutral to change settings in this mode.
- Shifting the transmission into gear saves all settings made, then cancels the Select mode and displays the Normal mode in all screens.

- Depending on the screen, pushing “RESET” saves settings or cancels the Select mode to display the Normal mode.

Push and hold “SELECT” and “RESET” for three seconds to enter the Select mode.



The following items can be set/adjusted in this mode:

- brightness
- shift timing indicator light
- clock
- stopwatch
- countdown clock
- system status
- maintenance counters

### TIP

To return to the Normal mode, push “SELECT” to scroll to “▲”, then push “RESET”.

## Adjusting the brightness

This function allows you to adjust the brightness of the tachometer panel and speedometer (“Meter panel”), the tachometer needle (“Needle”), and the multi-function display (“Display”).

1. Push “SELECT” to highlight “Brightness”.

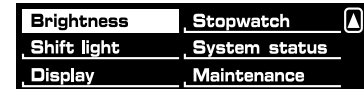

2. Push “RESET”, then push “SELECT” to scroll through the functions and to highlight an item.



3. Push “RESET”; the brightness level segments for the selected item starts flashing.
4. Push “SELECT” to highlight the desired brightness level.
5. Push “RESET” to set the brightness level.

# Instrument and control functions

6. Push “SELECT” to scroll to “

## Selecting the shift timing indicator light settings

3

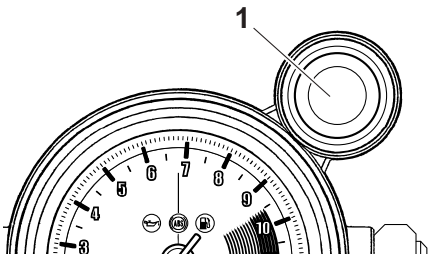

1. Shift timing indicator light

This function allows you to choose whether or not the shift timing indicator light is activated and whether it flashes or stays on when activated.

1. Push “SELECT” to highlight “Shift light”.



2. Push “RESET”.

3. Push “SELECT” to highlight “Operation selection”.

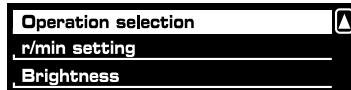

4. Push “RESET”. Push “SELECT” and highlight “On” to activate the indicator light; the indicator light comes on and stays on when activated.



Push “SELECT” and highlight “Flash” to activate the indicator light; the indicator light flashes when activated.



Push “SELECT” and highlight “Off” to deactivate the indicator light; the indicator light neither comes on nor flashes.



## TIP

The indicator light flashes once every two seconds to show that it has been deactivated. The indicator light goes off after this menu is exited.

5. Push “RESET” to set the shift timing indicator light activity.
6. Push “RESET” again to return to the previous menu.

## Setting the r/min in relation to the shift timing indicator light

This function allows you to select the engine speed at which the indicator light is activated and deactivated. All gears can be set to the same activation/deactivation r/min or the gears can be set individually.

Push “SELECT” to highlight “r/min setting”, then push “RESET”.

# Instrument and control functions

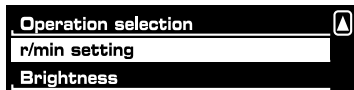

## TIP

The shift timing indicator light can be set to activate between 3000 r/min and 10500 r/min and deactivate between 3500 r/min and 11000 r/min in increments of 500 r/min.

To set all gears to the same r/min:

1. Push “SELECT” to highlight “All”.



2. Push “RESET”; “On” is displayed.



3. Push “RESET” and the r/min digits start flashing.
4. Push “SELECT” to highlight the engine speed at which the shift timing indicator light is activated.

5. Push “RESET” to set the selected engine speed. “Off” is highlighted and the r/min digits start flashing.
6. Push “SELECT” to highlight the engine speed at which the shift timing indicator light is deactivated.
7. Push “RESET” to set the selected engine speed.
8. Push “RESET” again to return to the previous menu.

To set individual gear r/min:

1. Push “SELECT” to highlight gears from “1st” through “5th”, then push “RESET”.



2. Push “RESET” and the r/min digits for the highlighted gear start flashing, then perform steps 4–8 under “To set all gears to the same r/min:” in order to set the r/min for the individual gears.

## TIP

After setting r/min for individual gears, if “All” is chosen, all previously set r/min for individual gears return to the default settings of 9000 (activation) and 11000 (deactivation).

3. Push “SELECT” to scroll to “A”, then push “RESET” to return to the previous menu.

## Setting the shift timing indicator light brightness

This function allows you to adjust the brightness of the shift timing indicator light.

1. Push “SELECT” to highlight “Brightness”.

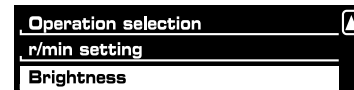

2. Push “RESET” and the brightness level segments start flashing.



# Instrument and control functions

3

3. Push “SELECT” to highlight the desired brightness level.
4. Push “RESET” to set the selected brightness level.
5. Push “RESET” to return to the previous menu.
6. Push “SELECT” to scroll to “

## Resetting all the brightness and shift timing indicator light functions

This resets **all** settings made to the brightness and shift timing indicator light functions.

1. Push “SELECT” to highlight “Display”.

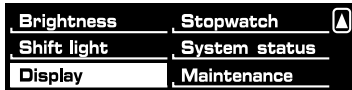

2. Push “RESET”; the following screen is displayed.

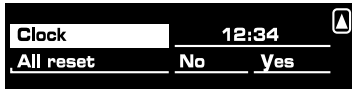

3. Push “RESET” and the hour digits start flashing.
4. Push “SELECT” to increment the hours.

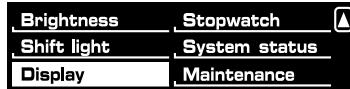

2. Push “RESET”.
3. Push “SELECT” to highlight “All reset”.

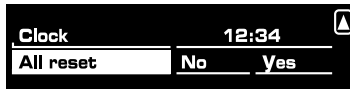

4. Push “RESET”, then push “SELECT” to highlight “Yes”.

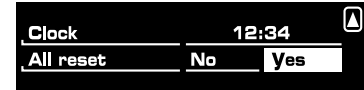

5. Push “RESET” to reset the brightness and shift timing light indicator values to the factory setting. The display returns to the Normal mode.

## **TIP**

To perform further multi-function display settings, enter the Select mode again by pushing and holding “SELECT” and “RESET” for three seconds.

## Using the stopwatch

The stopwatch can be activated as follows.

1. Push “SELECT” to highlight “Stopwatch”.

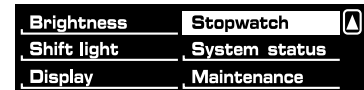

2. Push “RESET”.
3. Push “SELECT” to highlight “Stopwatch”.



4. Push "RESET".

The multi-function display changes to the Normal mode and the stopwatch is displayed in place of the clock.



5. Push "SELECT" to start the stopwatch.
6. Push the start switch "⊗" or "SELECT" to stop the stopwatch.
7. Push "RESET" to reset the stopwatch.

### TIP

- If neither "SELECT" nor "RESET" are pushed for one minute, the screen automatically changes to the Normal mode.
- Pushing "RESET" for two seconds changes the screen to the Normal mode.

- To perform further multi-function display settings, enter the Select mode again by pushing and holding "SELECT" and "RESET" for three seconds.

### Using the countdown clock

The countdown clock can be activated as follows.

1. Push "SELECT" to highlight "Stopwatch".
2. Push "RESET".
3. Push "SELECT" to highlight "Countdown".



4. Push "RESET". The multi-function display changes to the Normal mode, the stopwatch is displayed in place of the clock, and the transmission gear indicator changes to the countdown clock.



5. Push "SELECT" or shift into gear and the countdown clock starts counting down from "5". Simultaneously, the shift timing indicator light flashes according to the number displayed (i.e., when "5" is displayed, the indicator light flashes five times, when "4" is displayed, the indicator light flashes four times, etc.). The stopwatch starts counting when the countdown clock finishes counting.
6. Push the start switch "⊗" or "SELECT" to stop the countdown clock.
7. Push "RESET" to reset the countdown clock and stopwatch.
8. Repeat steps 5–7, or push "RESET" again for two seconds to enter the Normal mode.

### TIP

To perform further multi-function display settings, **be sure the transmission is in neutral**, then enter the Select mode again by pushing and holding "SELECT" and "RESET" for three seconds.

# Instrument and control functions

## Checking and resetting the system status

The status/readings of the following items are displayed, and the tripmeters can be reset.

- tripmeters and odometer
- fuel consumption
- air intake temperature
- throttle opening position

### TIP

- The “System status” menu cannot be entered if the fuel level warning light or coolant temperature warning light is on.
- If, when the engine is running while the system status menu is displayed, the fuel level warning light or coolant temperature warning light comes on, the Normal mode is automatically displayed.

1. Push “SELECT” to highlight “System status”, then push “RESET”.

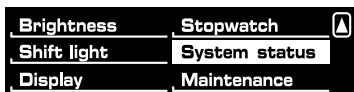

2. Push “SELECT” to highlight “Yes”, then push “RESET”. (Highlighting “No” and pushing “RESET” returns to the previous menu.)



The display changes to the status screen.

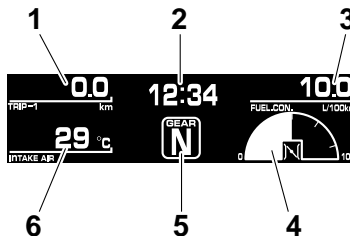

1. Odometer/tripmeter/fuel reserve tripmeter
2. Clock
3. Instantaneous fuel consumption
4. Throttle opening position display
5. Transmission gear indicator
6. Air intake temperature display

Push “SELECT” and the various tripmeters and the odometer are displayed in the following order: (TRIP-F) → TRIP-1 → TRIP-2 → ODO → (TRIP-F)  
Push “RESET” to reset a tripmeter.

### TIP

- For the UK: push “SELECT” for two seconds to switch between kilometers and miles.
- Pushing “RESET” displays the Normal mode for five seconds. Pushing “SELECT” and “RESET” for three seconds, changes the display to the Normal mode.
- To perform further multi-function display settings, enter the Select mode again by pushing and holding “SELECT” and “RESET” for three seconds.

## Resetting the maintenance counters

This function allows you to reset the maintenance counters for the tires, the engine oil, and an item of your choice.

1. Push “SELECT” to highlight “Maintenance”.

# Instrument and control functions

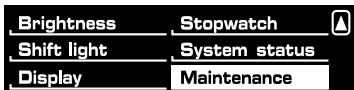

2. Push “RESET”.
3. Push “SELECT” to highlight the item to reset.



4. Push “RESET” to reset the item.

## TIP

- The bottom area was left blank for another item the rider cares to check the distance of since it has been changed, replaced or checked (i.e., air filter element, engine parts, etc.).
- Letters and numbers cannot be entered in the blank area.



5. Push “SELECT” to scroll to “⏏”.

6. Push “RESET” to return to the previous menu.

## Self-diagnosis device

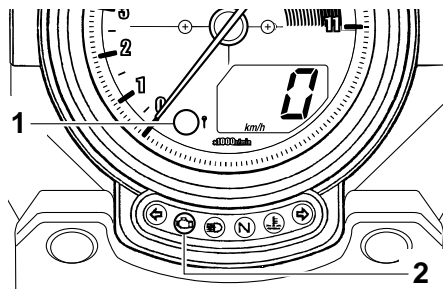

1. Immobilizer system indicator light
2. Engine trouble warning light “⚠️”

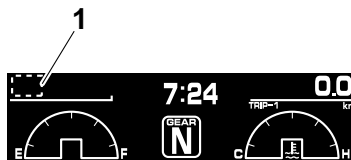

1. Error code display

## TIP

The display indicates error codes only in the Normal mode.

This model is equipped with a self-diagnosis device for various electrical circuits.

If a problem is detected in any of those circuits, the engine trouble warning light comes on and the display indicates an error code.

If the display indicates any error codes, note the code number and have a Yamaha dealer check the vehicle.

The self-diagnosis device also detects problems in the immobilizer system circuits.

If a problem is detected in any of the immobilizer system circuits, the immobilizer system indicator light flashes and the display indicates an error code.

## TIP

If the display indicates error code 52, this could be caused by transponder interference. If this error code appears, try the following.

1. Use the code re-registering key to start the engine.

# Instrument and control functions

## TIP

Make sure there are no other immobilizer keys close to the main switch, and do not keep more than one immobilizer key on the same key ring! Immobilizer system keys may cause signal interference, which may prevent the engine from starting.

3

2. If the engine starts, turn it off and try starting the engine with the standard keys.
3. If one or both of the standard keys do not start the engine, take the vehicle, the code re-registering key and both standard keys to a Yamaha dealer and have the standard keys re-registered.

ECA11591

## NOTICE

If the display indicates an error code, the vehicle should be checked as soon as possible in order to avoid engine damage.

## Handlebar switches

EAU1234J

### Left

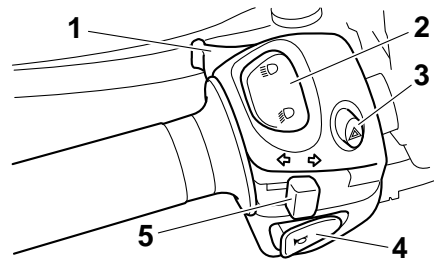

1. Pass switch “ $\equiv\bigcirc$ ”
2. Dimmer switch “ $\equiv\bigcirc/\bigcirc$ ”
3. Hazard switch “ $\triangle$ ”
4. Horn switch “ $\blacktriangleright$ ”
5. Turn signal switch “ $\leftarrow/\rightarrow$ ”

### Right

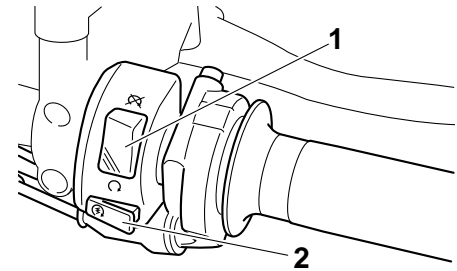

1. Engine stop switch “ $\bigcirc/\otimes$ ”
2. Start switch “ $\otimes$ ”

EAU12352

## Pass switch “ $\equiv\bigcirc$ ”

Press this switch to flash the headlight.

## TIP

When the dimmer switch is set to “ $\equiv\bigcirc$ ”, the passing switch has no effect.

EAU12401

## Dimmer switch “ $\equiv\bigcirc/\bigcirc$ ”

Set this switch to “ $\equiv\bigcirc$ ” for the high beam and to “ $\bigcirc$ ” for the low beam.



## Turn signal switch “↵/↶”

EAU12461

To signal a right-hand turn, push this switch to “↶”. To signal a left-hand turn, push this switch to “↵”. When released, the switch returns to the center position. To cancel the turn signal lights, push the switch in after it has returned to the center position.

## Horn switch “📢”

EAU12501

Press this switch to sound the horn.

## Engine stop switch “⊖/⊗”

EAU12661

Set this switch to “⊖” before starting the engine. Set this switch to “⊗” to stop the engine in case of an emergency, such as when the vehicle overturns or when the throttle cable is stuck.

## Start switch “🌀”

EAU12713

Push this switch to crank the engine with the starter. See page 5-1 for starting instructions prior to starting the engine.

The engine trouble warning light and ABS warning light may come on when the key is turned to “ON” and the start switch is pushed, but this does not indicate a malfunction.

EAU42342

## Hazard switch “⚠”

EAU12735

With the key in the “ON” or “P” position, use this switch to turn on the hazard lights (simultaneous flashing of all turn signal lights).

The hazard lights are used in case of an emergency or to warn other drivers when your vehicle is stopped where it might be a traffic hazard.

ECA10062

### **NOTICE**

**Do not use the hazard lights for an extended length of time with the engine not running, otherwise the battery may discharge.**

## Clutch lever

EAU12832

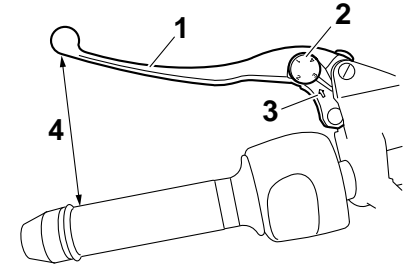

1. Clutch lever
2. Clutch lever position adjusting dial
3. Arrow mark
4. Distance between clutch lever and handlebar grip

The clutch lever is located on the left side of the handlebar. To disengage the clutch, pull the lever toward the handlebar grip. To engage the clutch, release the lever. The lever should be pulled rapidly and released slowly for smooth clutch operation.

The clutch lever is equipped with a clutch lever position adjusting dial. To adjust the distance between the clutch lever and the handlebar grip, turn the adjusting dial while holding the lever pushed away from the handlebar grip.

# Instrument and control functions

Make sure that the appropriate setting on the adjusting dial is aligned with the arrow mark on the clutch lever.

The clutch lever is equipped with a clutch switch, which is part of the ignition circuit cut-off system. (See page 3-32.)

3

## Shift pedal

EAU12872

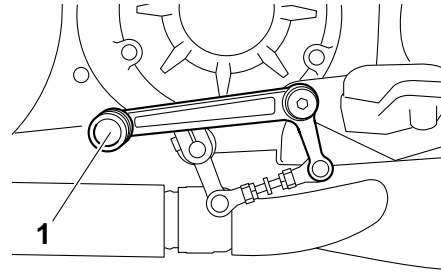

1. Shift pedal

The shift pedal is located on the left side of the motorcycle and is used in combination with the clutch lever when shifting the gears of the 5-speed constant-mesh transmission equipped on this motorcycle.

## Brake lever

EAU33854

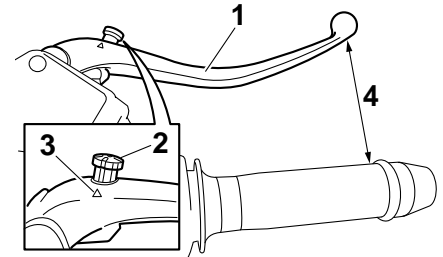

1. Brake lever
2. Brake lever position adjusting knob
3. “△” mark
4. Distance between brake lever and throttle grip

The brake lever is located on the right side of the handlebar. To apply the front brake, pull the lever toward the throttle grip.

The brake lever is equipped with a brake lever position adjusting knob. To adjust the distance between the brake lever and the throttle grip, turn the adjusting knob while holding the lever pushed away from the throttle grip. When the desired position is obtained,

be sure to set it by aligning a groove on the adjusting knob with the “△” mark on the brake lever.

## Brake pedal

EAU12944

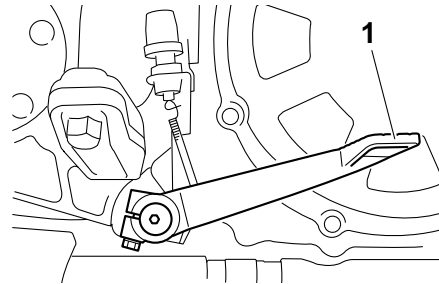

1. Brake pedal

The brake pedal is located on the right side of the motorcycle. To apply the rear brake, press down on the brake pedal.

## ABS

EAU51672

The Yamaha ABS (Anti-lock Brake System) features a dual electronic control system, which acts on the front and rear brakes independently.

Operate the brakes with ABS as you would conventional brakes. If the ABS is activated, a pulsating sensation may be felt at the brake lever or brake pedal. In this situation, continue to apply the brakes and let the ABS work; do not “pump” the brakes as this will reduce braking effectiveness.

3

### **WARNING**

EWA16051

**Always keep a sufficient distance from the vehicle ahead to match the riding speed even with ABS.**

- **The ABS performs best with long braking distances.**
- **On certain surfaces, such as rough or gravel roads, the braking distance may be longer with the ABS than without.**

The ABS is monitored by an ECU, which will revert the system to conventional braking if a malfunction occurs.

# Instrument and control functions

## TIP

- The ABS performs a self-diagnosis test each time the vehicle first starts off after the key is turned first starts off after the key is turned "ON" and the vehicle has traveled at a speed of 10 km/h (6 mi/h) or higher. During this test, a "clicking" noise can be heard from under the seat, and if the brake lever or brake pedal is even slightly applied, a vibration can be felt at the lever and pedal, but these do not indicate a malfunction.
- This ABS has a test mode which allows the owner to experience the pulsation at the brake lever or brake pedal when the ABS is operating. However, special tools are required, so please consult your Yamaha dealer.

ECA16121

## NOTICE

Keep any type of magnets (including magnetic pick-up tools, magnetic screwdrivers, etc.) away from the front and rear wheel hubs, otherwise the magnetic rotors equipped in the

wheel hubs may be damaged, resulting in improper performance of the ABS system.

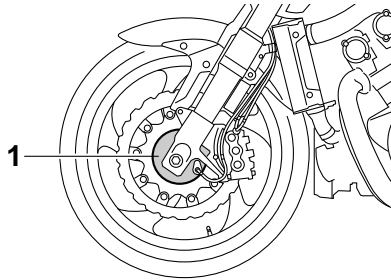

1. Front wheel hub

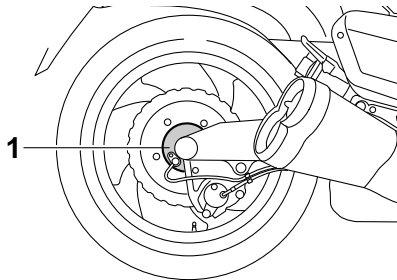

1. Rear wheel hub

EAU46851

## Fuel tank cap

### To remove the fuel tank cap

1. Pull the rider seat backrest release lever on the left side of the vehicle as shown. The backrest will slide forward.

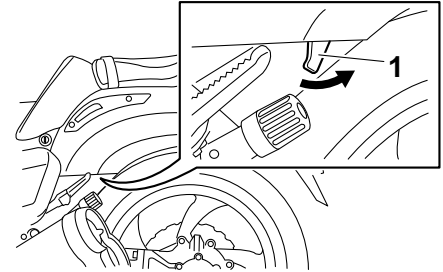

1. Rider seat backrest release lever

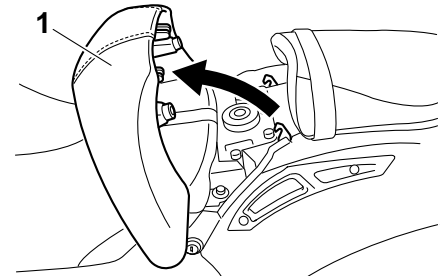

1. Rider seat backrest

2. Insert the key into the lock, and then turn it 1/4 turn clockwise. The lock will be released and the fuel tank cap can be removed.

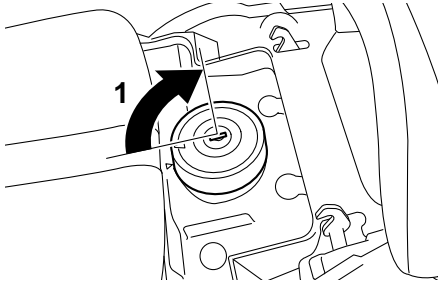

1. Unlock.

## To install the fuel tank cap

1. Insert the fuel tank cap into the tank opening with the key inserted in the lock and with the mark on the cap aligned with the mark on the fuel tank.

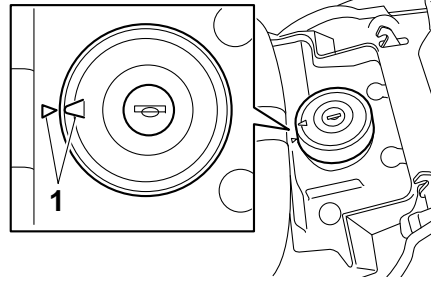

1. Match marks
2. Turn the key counterclockwise to the original position, and then remove it.
3. Return the backrest to the original position.

## TIP

The fuel tank cap cannot be installed unless the key is in the lock. In addition, the key cannot be removed if the cap is not properly installed and locked.

EWA10132

## WARNING

**Make sure that the fuel tank cap is properly installed before riding. Leaking fuel is a fire hazard.**

## Fuel

Make sure there is sufficient gasoline in the tank.

EWA10882

## WARNING

**Gasoline and gasoline vapors are extremely flammable. To avoid fires and explosions and to reduce the risk of injury when refueling, follow these instructions.**

1. Before refueling, turn off the engine and be sure that no one is sitting on the vehicle. Never refuel while smoking, or while in the vicinity of sparks, open flames, or other sources of ignition such as the pilot lights of water heaters and clothes dryers.
2. Do not overfill the fuel tank. Stop filling when the fuel reaches the bottom of the filler tube. Because fuel expands when it heats up, heat from the engine or the sun can cause fuel to spill out of the fuel tank.

# Instrument and control functions

3

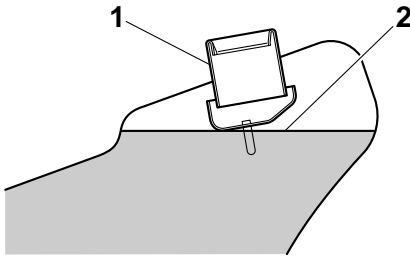

1. Fuel tank filler tube
2. Maximum fuel level
3. Wipe up any spilled fuel immediately. **NOTICE: Immediately wipe off spilled fuel with a clean, dry, soft cloth, since fuel may deteriorate painted surfaces or plastic parts.** [ECA10072]
4. Be sure to securely close the fuel tank cap.

EWA15152

## **! WARNING**

Gasoline is poisonous and can cause injury or death. Handle gasoline with care. Never siphon gasoline by mouth. If you should swallow some gasoline or inhale a lot of gasoline vapor, or get some gasoline in your eyes, see your doctor immediately. If

gasoline spills on your skin, wash with soap and water. If gasoline spills on your clothing, change your clothes.

EAU54602

### **Recommended fuel:**

Premium unleaded gasoline (Gasohol [E10] acceptable)

### **Fuel tank capacity:**

15 L (4.0 US gal, 3.3 Imp.gal)

### **Fuel reserve amount (when the fuel level warning light comes on):**

3.9 L (1.03 US gal, 0.86 Imp.gal)

ECA11401

## **NOTICE**

**Use only unleaded gasoline. The use of leaded gasoline will cause severe damage to internal engine parts, such as the valves and piston rings, as well as to the exhaust system.**

Your Yamaha engine has been designed to use premium unleaded gasoline with a research octane number of 95 or higher. If knocking (or pinging) occurs, use a gasoline of a different

brand. Use of unleaded fuel will extend spark plug life and reduce maintenance costs.

## **Gasohol**

There are two types of gasohol: gasohol containing ethanol and that containing methanol. Gasohol containing ethanol can be used if the ethanol content does not exceed 10% (E10). Gasohol containing methanol is not recommended by Yamaha because it can cause damage to the fuel system or vehicle performance problems.

## Fuel tank breather hose and overflow hose

EAU51172

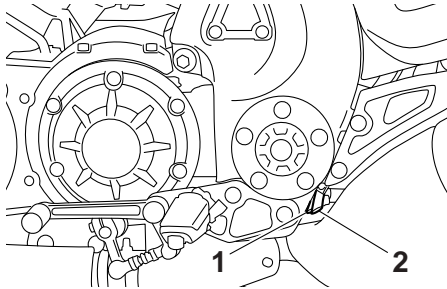

1. Fuel tank breather hose
2. Fuel tank overflow hose

Before operating the motorcycle:

- Check each hose connection.
- Check each hose for cracks or damage, and replace if necessary.
- Make sure that the end of each hose is not blocked, and clean if necessary.

## Catalytic converters

EAU13447

This vehicle is equipped with catalytic converters in the exhaust system.

EWA10863

### **⚠ WARNING**

The exhaust system is hot after operation. To prevent a fire hazard or burns:

- Do not park the vehicle near possible fire hazards such as grass or other materials that easily burn.
- Park the vehicle in a place where pedestrians or children are not likely to touch the hot exhaust system.
- Make sure that the exhaust system has cooled down before doing any maintenance work.
- Do not allow the engine to idle more than a few minutes. Long idling can cause a build-up of heat.

### **NOTICE**

Use only unleaded gasoline. The use of leaded gasoline will cause unrepairable damage to the catalytic converter.

ECA10702

# Instrument and control functions

EAU46843

## Seats

### Rider seat

#### To remove the rider seat

1. Pull the rider seat backrest release lever on the left side of the vehicle as shown. The backrest will slide forward.

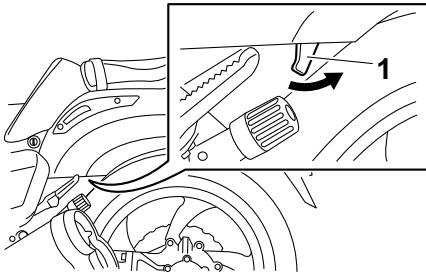

1. Rider seat backrest release lever

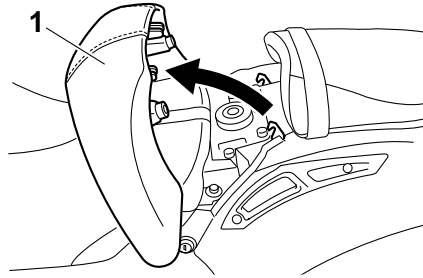

1. Rider seat backrest

2. Remove the bolts, and then pull the rider seat off.

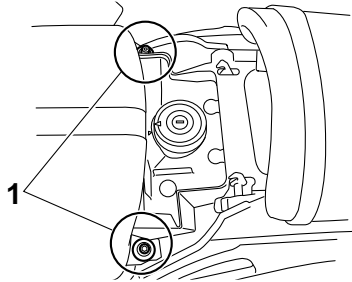

1. Bolt

#### To install the rider seat

1. Insert the projection on the front of the rider seat into the seat holder as shown.

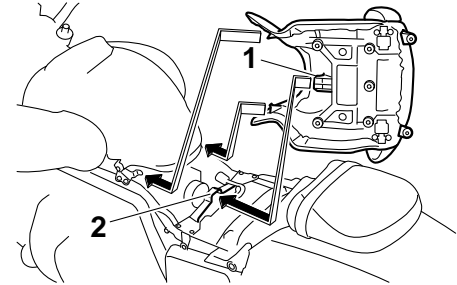

1. Projection  
2. Seat holder

2. Place the rider seat in the original position, and then tighten the bolts.

#### **TIP**

Make sure that the rider seat is properly secured before riding.

3. Return the backrest to the original position.

### Passenger seat

#### To remove the passenger seat

1. Pull the rider seat backrest release lever on the left side of the vehicle as shown. The backrest will slide forward.



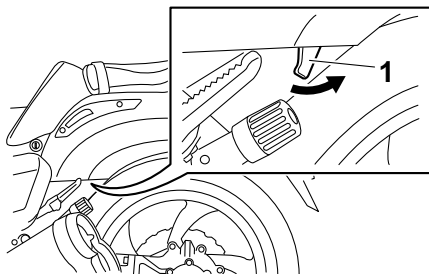

1. Rider seat backrest release lever
2. Remove the bolts, and then pull the passenger seat off.

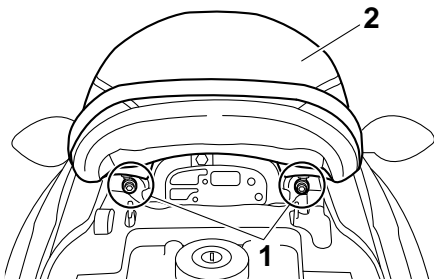

1. Bolt
2. Passenger seat

## To install the passenger seat

1. Insert the projection on the passenger seat into the seat holder as shown.

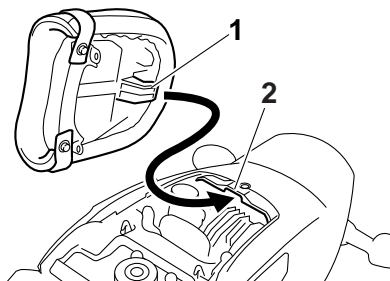

1. Projection
2. Seat holder
2. Place the passenger seat in the original position, and then install the bolts.
3. Return the backrest to the original position.

## TIP

Make sure that the passenger seat is properly secured before riding.

## Adjusting the front fork

### **WARNING**

Always adjust both fork legs equally, otherwise poor handling and loss of stability may result.

This front fork is equipped with spring preload adjusting bolts, rebound damping force adjusting knobs and compression damping force adjusting screws.

### **NOTICE**

To avoid damaging the mechanism, do not attempt to turn beyond the maximum or minimum settings.

## Spring preload

To increase the spring preload and thereby harden the suspension, turn the adjusting bolt on each fork leg in direction (a). To decrease the spring preload and thereby soften the suspension, turn the adjusting bolt on each fork leg in direction (b).

# Instrument and control functions

3

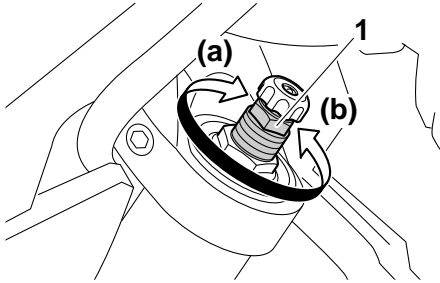

1. Spring preload adjusting bolt

The spring preload setting is determined by measuring distance A, shown in the illustration. The shorter distance A is, the higher the spring preload; the longer distance A is, the lower the spring preload.

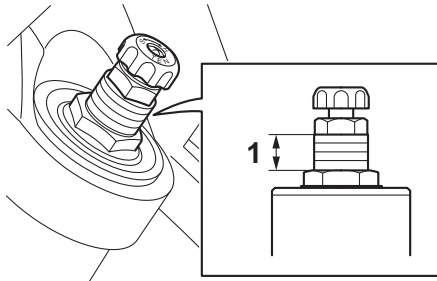

1. Distance A

## Spring preload setting:

Minimum (soft):

Distance A = 14.0 mm (0.55 in)

Standard:

Distance A = 9.0 mm (0.35 in)

Maximum (hard):

Distance A = 0 mm (0.00 in)

## Rebound damping force

To increase the rebound damping force and thereby harden the rebound damping, turn the adjusting knob on each fork leg in direction (a). To decrease the rebound damping force and thereby soften the rebound damping, turn the adjusting knob on each fork leg in direction (b).

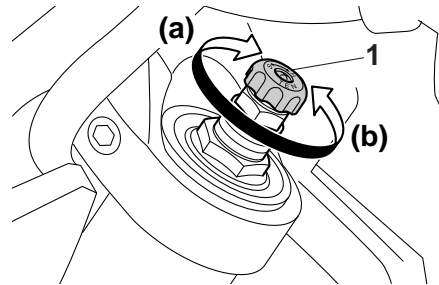

1. Rebound damping force adjusting knob

## Rebound damping setting:

Minimum (soft):

17 click(s) in direction (b)\*

Standard:

12 click(s) in direction (b)\*

Maximum (hard):

1 click(s) in direction (b)\*

\* With the adjusting knob fully turned in direction (a)

## Compression damping force

To increase the compression damping force and thereby harden the compression damping, turn the adjusting screw on each fork leg in direction (a). To decrease the compression damping force and thereby soften the compression damping, turn the adjusting screw on each fork leg in direction (b).

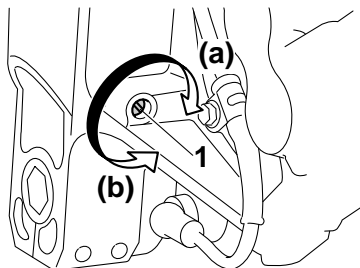

1. Compression damping force adjusting screw

### Compression damping setting:

Minimum (soft):

20 click(s) in direction (b)\*

Standard:

12 click(s) in direction (b)\*

Maximum (hard):

1 click(s) in direction (b)\*

\* With the adjusting screw fully turned in direction (a)

### TIP

Although the total number of clicks of a damping force adjusting mechanism may not exactly match the above specifications due to small differences in production, the actual number of clicks always represents the entire adjusting range. To obtain a precise ad-

justment, it would be advisable to check the number of clicks of each damping force adjusting mechanism and to modify the specifications as necessary.

## Adjusting the shock absorber assembly

This shock absorber assembly is equipped with a spring preload adjusting knob and rebound and compression damping force adjusting knobs.

ECA10102

### NOTICE

**To avoid damaging the mechanism, do not attempt to turn beyond the maximum or minimum settings.**

### Spring preload

To increase the spring preload and thereby harden the suspension, turn the adjusting knob in direction (a). To decrease the spring preload and thereby soften the suspension, turn the adjusting knob in direction (b).

### TIP

Align the appropriate mark on the adjusting mechanism with the end of the adjusting knob.

# Instrument and control functions

3

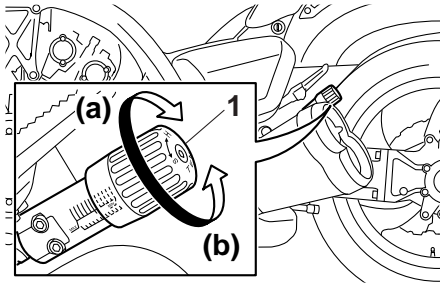

1. Spring preload adjusting knob

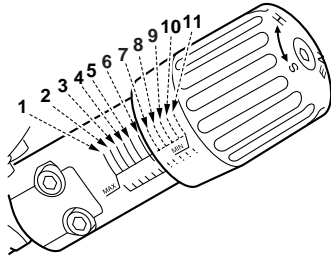

### Spring preload setting:

- Minimum (soft): 11
- Standard: 6
- Maximum (hard): 1

### Rebound damping force

To increase the rebound damping force and thereby harden the rebound damping, turn the adjusting knob in direction (a). To decrease the rebound damping force and thereby soften the rebound damping, turn the adjusting knob in direction (b).

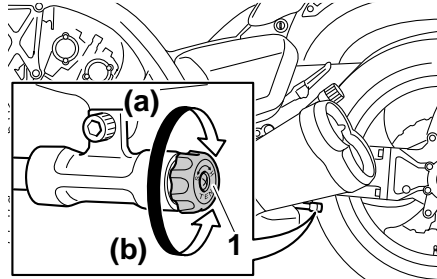

1. Rebound damping force adjusting knob

### Rebound damping setting:

- Minimum (soft): 20 clicks in direction (b)\*
  - Standard: 12 clicks in direction (b)\*
  - Maximum (hard): 3 clicks in direction (b)\*
- \* With the adjusting knob fully turned in direction (a)

### Compression damping force

To increase the compression damping force and thereby harden the compression damping, turn the adjusting knob in direction (a). To decrease the compression damping force and thereby soften the compression damping, turn the adjusting knob in direction (b).

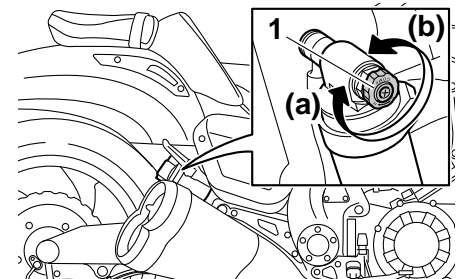

1. Compression damping force adjusting knob

### Compression damping setting:

- Minimum (soft): 12 clicks in direction (b)\*
  - Standard: 10 clicks in direction (b)\*
  - Maximum (hard): 1 clicks in direction (b)\*
- \* With the adjusting knob fully turned in direction (a)

## TIP

To obtain a precise adjustment, it is advisable to check the actual total number of clicks or turns of each damping force adjusting mechanism. This adjustment range may not exactly match the specifications listed due to small differences in production.

EWA10222

## WARNING

**This shock absorber assembly contains highly pressurized nitrogen gas. Read and understand the following information before handling the shock absorber assembly.**

- Do not tamper with or attempt to open the cylinder assembly.
- Do not subject the shock absorber assembly to an open flame or other high heat source. This may cause the unit to explode due to excessive gas pressure.
- Do not deform or damage the cylinder in any way. Cylinder damage will result in poor damping performance.

- Do not dispose of a damaged or worn-out shock absorber assembly yourself. Take the shock absorber assembly to a Yamaha dealer for any service.

## Luggage strap holders

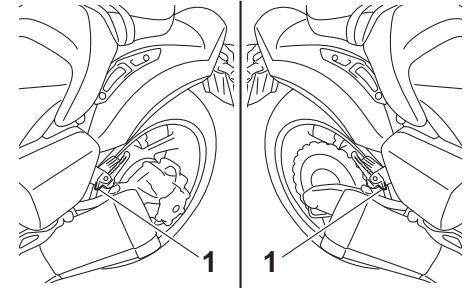

1. Luggage strap holder

There is a luggage strap holder on each passenger footrest.

# Instrument and control functions

---

3

## EXUP system

EAU41942

This model is equipped with Yamaha's EXUP (EXhaust Ultimate Power valve) system. This system boosts engine power by means of a valve that regulates the inner diameter of the exhaust pipe. The EXUP system valve is constantly adjusted in accordance with the engine speed by a computer-controlled servomotor.

ECA15611

### NOTICE

**The EXUP system has been set and extensively tested at the Yamaha factory. Changing these settings without sufficient technical knowledge may result in poor performance of or damage to the engine.**

---

## Sidestand

EAU15306

The sidestand is located on the left side of the frame. Raise the sidestand or lower it with your foot while holding the vehicle upright.

### TIP

The built-in sidestand switch is part of the ignition circuit cut-off system, which cuts the ignition in certain situations. (See the following section for an explanation of the ignition circuit cut-off system.)

---

EWA10242

### WARNING

**The vehicle must not be ridden with the sidestand down, or if the sidestand cannot be properly moved up (or does not stay up), otherwise the sidestand could contact the ground and distract the operator, resulting in a possible loss of control. Yamaha's ignition circuit cut-off system has been designed to assist the operator in fulfilling the responsibility of raising the sidestand before starting off. Therefore, check**

**this system regularly and have a Yamaha dealer repair it if it does not function properly.**

---

EAU44893

## Ignition circuit cut-off system

The ignition circuit cut-off system (comprising the sidestand switch, clutch switch and neutral switch) has the following functions.

- It prevents starting when the transmission is in gear and the sidestand is up, but the clutch lever is not pulled.
- It prevents starting when the transmission is in gear and the clutch lever is pulled, but the sidestand is still down.
- It cuts the running engine when the transmission is in gear and the sidestand is moved down.

Periodically check the operation of the ignition circuit cut-off system according to the following procedure.

# Instrument and control functions

3

With the engine turned off:  
1. Move the sidestand down.  
2. Make sure that the engine stop switch is set to "O".  
3. Turn the key on.  
4. Shift the transmission into the neutral position.  
5. Push the start switch.  
**Does the engine start?**

YES NO

With the engine still running:  
6. Move the sidestand up.  
7. Keep the clutch lever pulled.  
8. Shift the transmission into gear.  
9. Move the sidestand down.  
**Does the engine stall?**

YES NO

After the engine has stalled:  
10. Move the sidestand up.  
11. Keep the clutch lever pulled.  
12. Push the start switch.  
**Does the engine start?**

YES NO

The system is OK. **The motorcycle can be ridden.**

## **WARNING**

**If a malfunction is noted, have a Yamaha dealer check the system before riding.**

The neutral switch may not be working correctly.  
**The motorcycle should not be ridden** until checked by a Yamaha dealer.

The sidestand switch may not be working correctly.  
**The motorcycle should not be ridden** until checked by a Yamaha dealer.

The clutch switch may not be working correctly.  
**The motorcycle should not be ridden** until checked by a Yamaha dealer.



# For your safety – pre-operation checks

EAU15599

Inspect your vehicle each time you use it to make sure the vehicle is in safe operating condition. Always follow the inspection and maintenance procedures and schedules described in the Owner's Manual.

EWA11152

## **WARNING**

**Failure to inspect or maintain the vehicle properly increases the possibility of an accident or equipment damage. Do not operate the vehicle if you find any problem. If a problem cannot be corrected by the procedures provided in this manual, have the vehicle inspected by a Yamaha dealer.**

4

Before using this vehicle, check the following points:

ITEM	CHECKS	PAGE
Fuel	<ul style="list-style-type: none"><li>• Check fuel level in fuel tank.</li><li>• Refuel if necessary.</li><li>• Check fuel line for leakage.</li><li>• Check fuel tank breather hose and overflow hose for obstructions, cracks or damage, and check hose connections.</li></ul>	3-22, 3-24
Engine oil	<ul style="list-style-type: none"><li>• Check oil level in engine.</li><li>• If necessary, add recommended oil to specified level.</li><li>• Check vehicle for oil leakage.</li></ul>	6-11
Final gear oil	<ul style="list-style-type: none"><li>• Check vehicle for oil leakage.</li></ul>	6-14
Coolant	<ul style="list-style-type: none"><li>• Check coolant level in reservoir.</li><li>• If necessary, add recommended coolant to specified level.</li><li>• Check cooling system for leakage.</li></ul>	6-16
Front brake	<ul style="list-style-type: none"><li>• Check operation.</li><li>• If soft or spongy, have Yamaha dealer bleed hydraulic system.</li><li>• Check brake pads for wear.</li><li>• Replace if necessary.</li><li>• Check fluid level in reservoir.</li><li>• If necessary, add specified brake fluid to specified level.</li><li>• Check hydraulic system for leakage.</li></ul>	6-25, 6-25

# For your safety – pre-operation checks

ITEM	CHECKS	PAGE
<b>Rear brake</b>	<ul style="list-style-type: none"> <li>• Check operation.</li> <li>• If soft or spongy, have Yamaha dealer bleed hydraulic system.</li> <li>• Check brake pads for wear.</li> <li>• Replace if necessary.</li> <li>• Check fluid level in reservoir.</li> <li>• If necessary, add specified brake fluid to specified level.</li> <li>• Check hydraulic system for leakage.</li> </ul>	6-25, 6-25
<b>Clutch</b>	<ul style="list-style-type: none"> <li>• Check operation.</li> <li>• If soft or spongy, have Yamaha dealer bleed hydraulic system.</li> <li>• Check hydraulic system for leakage.</li> </ul>	6-23
<b>Throttle grip</b>	<ul style="list-style-type: none"> <li>• Make sure that operation is smooth.</li> <li>• Check throttle grip free play.</li> <li>• If necessary, have Yamaha dealer adjust throttle grip free play and lubricate cable and grip housing.</li> </ul>	6-20, 6-27
<b>Control cables</b>	<ul style="list-style-type: none"> <li>• Make sure that operation is smooth.</li> <li>• Lubricate if necessary.</li> </ul>	6-27
<b>Wheels and tires</b>	<ul style="list-style-type: none"> <li>• Check for damage.</li> <li>• Check tire condition and tread depth.</li> <li>• Check air pressure.</li> <li>• Correct if necessary.</li> </ul>	6-21, 6-23
<b>Brake and shift pedals</b>	<ul style="list-style-type: none"> <li>• Make sure that operation is smooth.</li> <li>• Lubricate pedal pivoting points if necessary.</li> </ul>	6-28
<b>Brake and clutch levers</b>	<ul style="list-style-type: none"> <li>• Make sure that operation is smooth.</li> <li>• Lubricate lever pivoting points if necessary.</li> </ul>	6-28
<b>Sidestand</b>	<ul style="list-style-type: none"> <li>• Make sure that operation is smooth.</li> <li>• Lubricate pivot if necessary.</li> </ul>	6-29
<b>Chassis fasteners</b>	<ul style="list-style-type: none"> <li>• Make sure that all nuts, bolts and screws are properly tightened.</li> <li>• Tighten if necessary.</li> </ul>	—
<b>Instruments, lights, signals and switches</b>	<ul style="list-style-type: none"> <li>• Check operation.</li> <li>• Correct if necessary.</li> </ul>	—

## For your safety – pre-operation checks

ITEM	CHECKS	PAGE
<b>Sidestand switch</b>	<ul style="list-style-type: none"><li>• Check operation of ignition circuit cut-off system.</li><li>• If system is not working correctly, have Yamaha dealer check vehicle.</li></ul>	3-31

# Operation and important riding points

---

EAU15952

Read the Owner's Manual carefully to become familiar with all controls. If there is a control or function you do not understand, ask your Yamaha dealer.

EWA10272

## **WARNING**

**Failure to familiarize yourself with the controls can lead to loss of control, which could cause an accident or injury.**

---

5

EAU48712

## **TIP**

This model is equipped with:

- a lean angle sensor to stop the engine in case of a turnover. In this case, the display will indicate error code 30, but this is not a malfunction. Turn the key to "OFF" and then to "ON" to clear the error code. Failing to do so will prevent the engine from starting even though the engine will crank when pushing the start switch.
  - an engine auto-stop system. The engine stops automatically if left idling for 20 minutes. If the engine stops, simply push the start switch to restart the engine.
- 

EAU51693

## **Starting the engine**

In order for the ignition circuit cut-off system to enable starting, one of the following conditions must be met:

- The transmission is in the neutral position.
  - The transmission is in gear with the clutch lever pulled and the sidestand up.
- See page 3-32 for more information.

1. Turn the key to "ON" and make sure that the engine stop switch is set to "○".

The following warning lights and indicator lights should come on for a few seconds, then go off.

- Oil level warning light
- Fuel level warning light
- Coolant temperature warning light
- Engine trouble warning light
- Shift timing indicator light
- Immobilizer system indicator light

ECA11834

## NOTICE

If a warning or indicator light does not come on initially when the key is turned to "ON", or if a warning or indicator light remains on, see page 3-4 for the corresponding warning and indicator light circuit check.

The ABS warning light should come on when the main switch is turned to "ON" and then go off after traveling at a speed of 10 km/h (6 mi/h) or higher.

ECA17682

## NOTICE

If the ABS warning light does not come on and then go off as explained above, see page 3-4 for the warning light circuit check.

2. Shift the transmission into the neutral position. The neutral indicator light should come on. If not, ask a Yamaha dealer to check the electrical circuit.
3. Start the engine by pushing the start switch.

If the engine fails to start, release the start switch, wait a few seconds, and then try again. Each starting attempt should be as short as possible to preserve the battery. Do not crank the engine more than 10 seconds on any one attempt.

ECA11043

## NOTICE

For maximum engine life, never accelerate hard when the engine is cold!

EAU16673

## Shifting

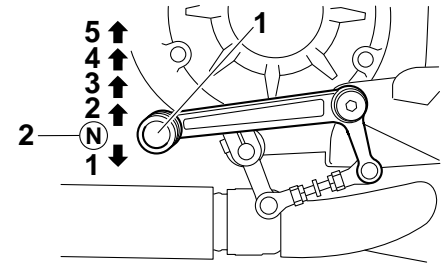

1. Shift pedal
2. Neutral position

Shifting gears lets you control the amount of engine power available for starting off, accelerating, climbing hills, etc.

The gear positions are shown in the illustration.

## TIP

To shift the transmission into the neutral position, press the shift pedal down repeatedly until it reaches the end of its travel, and then slightly raise it.

# Operation and important riding points

---

## NOTICE

ECA10261

- Even with the transmission in the neutral position, do not coast for long periods of time with the engine off, and do not tow the motorcycle for long distances. The transmission is properly lubricated only when the engine is running. Inadequate lubrication may damage the transmission.
  - Always use the clutch while changing gears to avoid damaging the engine, transmission, and drive train, which are not designed to withstand the shock of forced shifting.
- 

## Tips for reducing fuel consumption

EAU16811

Fuel consumption depends largely on your riding style. Consider the following tips to reduce fuel consumption:

- Shift up swiftly, and avoid high engine speeds during acceleration.
- Do not rev the engine while shifting down, and avoid high engine speeds with no load on the engine.
- Turn the engine off instead of letting it idle for an extended length of time (e.g., in traffic jams, at traffic lights or at railroad crossings).

## Engine break-in

EAU16842

There is never a more important period in the life of your engine than the period between 0 and 1600 km (1000 mi). For this reason, you should read the following material carefully.

Since the engine is brand new, do not put an excessive load on it for the first 1600 km (1000 mi). The various parts in the engine wear and polish themselves to the correct operating clearances. During this period, prolonged full-throttle operation or any condition that might result in engine overheating must be avoided.

EAU17124

## 0–1000 km (0–600 mi)

Avoid prolonged operation above 4800 r/min. **NOTICE: After 1000 km (600 mi) of operation, the engine oil and final gear oil must be changed, and the oil filter cartridge or element replaced.** [ECA10333]

## 1000–1600 km (600–1000 mi)

Avoid prolonged operation above 5700 r/min.

## 1600 km (1000 mi) and beyond

The vehicle can now be operated normally.

ECA10311

### **NOTICE**

- Keep the engine speed out of the tachometer red zone.
- If any engine trouble should occur during the engine break-in period, immediately have a Yamaha dealer check the vehicle.

EAU17214

## Parking

When parking, stop the engine, and then remove the key from the main switch.

EWA10312

### **⚠ WARNING**

- Since the engine and exhaust system can become very hot, park in a place where pedestrians or children are not likely to touch them and be burned.
- Do not park on a slope or on soft ground, otherwise the vehicle may overturn, increasing the risk of a fuel leak and fire.
- Do not park near grass or other flammable materials which might catch fire.

# Periodic maintenance and adjustment

---

EAU17246

EWA15123

EAU17303

Periodic inspection, adjustment, and lubrication will keep your vehicle in the safest and most efficient condition possible. Safety is an obligation of the vehicle owner/operator. The most important points of vehicle inspection, adjustment, and lubrication are explained on the following pages.

The intervals given in the periodic maintenance charts should be simply considered as a general guide under normal riding conditions. However, depending on the weather, terrain, geographical location, and individual use, the maintenance intervals may need to be shortened.

## **WARNING**

EWA10322

**Failure to properly maintain the vehicle or performing maintenance activities incorrectly may increase your risk of injury or death during service or while using the vehicle. If you are not familiar with vehicle service, have a Yamaha dealer perform service.**

---

## **WARNING**

**Turn off the engine when performing maintenance unless otherwise specified.**

- **A running engine has moving parts that can catch on body parts or clothing and electrical parts that can cause shocks or fires.**
- **Running the engine while servicing can lead to eye injury, burns, fire, or carbon monoxide poisoning – possibly leading to death. See page 1-3 for more information about carbon monoxide.**

Emission controls not only function to ensure cleaner air, but are also vital to proper engine operation and maximum performance. In the following periodic maintenance charts, the services related to emissions control are grouped separately. These services require specialized data, knowledge, and equipment. Maintenance, replacement, or repair of the emission control devices and systems may be performed by any repair establishment or individual that is certified (if applicable). Yamaha dealers are trained and equipped to perform these particular services.

## **WARNING**

EWA15461

**Brake discs, calipers, drums, and linings can become very hot during use. To avoid possible burns, let brake components cool before touching them.**

---



## Owner's tool kits

EAU63410

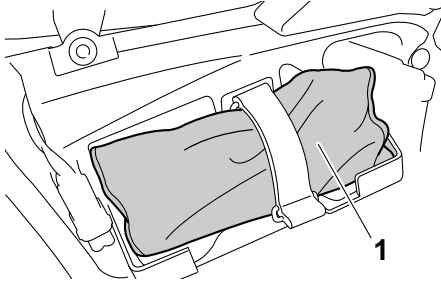

1. Owner's tool kit

The owner's tool kit is located behind panel A. (See page 6-8.)

Also, an additional tool kit was handed out separately at the time of vehicle purchase.

The service information included in this manual and the tools provided in the tool kits are intended to assist you in the performance of preventive maintenance and minor repairs. However, other tools such as a torque wrench may be necessary to perform certain maintenance work correctly.

## TIP

If you do not have the tools or experience required for a particular job, have a Yamaha dealer perform it for you.

# Periodic maintenance and adjustment

EAU46862

## TIP

- The annual checks must be performed every year, except if a kilometer-based maintenance, or for the UK, a mileage-based maintenance, is performed instead.
- From 50000 km (30000 mi), repeat the maintenance intervals starting from 10000 km (6000 mi).
- Items marked with an asterisk should be performed by a Yamaha dealer as they require special tools, data and technical skills.

EAU46911

## Periodic maintenance chart for the emission control system

NO.	ITEM	CHECK OR MAINTENANCE JOB	ODOMETER READING					ANNUAL CHECK
			1000 km (600 mi)	10000 km (6000 mi)	20000 km (12000 mi)	30000 km (18000 mi)	40000 km (24000 mi)	
1	* Fuel line	• Check fuel hoses for cracks or damage.		√	√	√	√	√
2	* Spark plugs	• Check condition. • Clean.		√		√		
		• Replace.			√		√	
3	* Valves	• Check valve clearance. • Adjust.	Every 40000 km (24000 mi)					
4	* Fuel injection system	• Adjust synchronization.	√	√	√	√	√	√
5	* Mufflers and exhaust pipes	• Check the screw clamps for looseness.	√	√	√	√	√	
6	* Air induction system	• Check the air cut-off valve, reed valve, and hose for damage. • Replace any damaged parts if necessary.		√	√	√	√	√

# Periodic maintenance and adjustment

EAU1770M

## General maintenance and lubrication chart

NO.	ITEM	CHECK OR MAINTENANCE JOB	ODOMETER READING					ANNUAL CHECK
			1000 km (600 mi)	10000 km (6000 mi)	20000 km (12000 mi)	30000 km (18000 mi)	40000 km (24000 mi)	
1	* Air filter element	• Replace.					√	
2	* Clutch	• Check operation, fluid level and vehicle for fluid leakage.	√	√	√	√	√	
3	* Front brake	• Check operation, fluid level and vehicle for fluid leakage.	√	√	√	√	√	√
		• Replace brake pads.	Whenever worn to the limit					
4	* Rear brake	• Check operation, fluid level and vehicle for fluid leakage.	√	√	√	√	√	√
		• Replace brake pads.	Whenever worn to the limit					
5	* Brake hoses	• Check for cracks or damage. • Check for correct routing and clamping.		√	√	√	√	√
		• Replace.	Every 4 years					
6	* Brake fluid	• Change.	Every 2 years					
7	* Wheels	• Check runout and for damage.		√	√	√	√	
8	* Tires	• Check tread depth and for damage. • Replace if necessary. • Check air pressure. • Correct if necessary.		√	√	√	√	√
9	* Wheel bearings	• Check bearings for looseness or damage.		√	√	√	√	

# Periodic maintenance and adjustment

NO.	ITEM	CHECK OR MAINTENANCE JOB	ODOMETER READING					ANNUAL CHECK
			1000 km (600 mi)	10000 km (6000 mi)	20000 km (12000 mi)	30000 km (18000 mi)	40000 km (24000 mi)	
10 *	Swingarm	• Check operation and for excessive play.		√	√	√	√	
		• Lubricate with lithium-soap-based grease.	Every 50000 km (30000 mi)					
11 *	Steering bearings	• Check bearing play and steering for roughness.	√	√	√	√	√	
		• Lubricate with lithium-soap-based grease.	Every 50000 km (30000 mi)					
12 *	Chassis fasteners	• Make sure that all nuts, bolts and screws are properly tightened.		√	√	√	√	√
13	Brake lever pivot shaft	• Lubricate with silicone grease.		√	√	√	√	√
14	Brake pedal pivot shaft	• Lubricate with lithium-soap-based grease.		√	√	√	√	√
15	Clutch lever pivot shaft	• Lubricate with silicone grease.		√	√	√	√	√
16	Shift pedal pivot shaft	• Lubricate with lithium-soap-based grease.		√	√	√	√	√
17	Sidestand	• Check operation. • Lubricate with lithium-soap-based grease.		√	√	√	√	√
18 *	Sidestand switch	• Check operation.	√	√	√	√	√	√
19 *	Front fork	• Check operation and for oil leakage.		√	√	√	√	
20 *	Shock absorber assembly	• Check operation and shock absorber for oil leakage.		√	√	√	√	

# Periodic maintenance and adjustment

NO.	ITEM	CHECK OR MAINTENANCE JOB	ODOMETER READING					ANNUAL CHECK
			1000 km (600 mi)	10000 km (6000 mi)	20000 km (12000 mi)	30000 km (18000 mi)	40000 km (24000 mi)	
21	* Rear suspension re- lay arm and con- necting arm pivoting points	<ul style="list-style-type: none"> <li>• Check operation.</li> </ul>		√	√	√	√	
22	Engine oil	<ul style="list-style-type: none"> <li>• Change.</li> <li>• Check oil level and vehicle for oil leakage.</li> </ul>	√	√	√	√	√	√
23	Engine oil filter car- tridge	<ul style="list-style-type: none"> <li>• Replace.</li> </ul>	√		√		√	
24	* Cooling system	<ul style="list-style-type: none"> <li>• Check coolant level and vehicle for coolant leakage.</li> </ul>		√	√	√	√	√
		<ul style="list-style-type: none"> <li>• Change coolant.</li> </ul>	Every 3 years					
25	* EXUP system	<ul style="list-style-type: none"> <li>• Check operation, cable free play and pulley position.</li> </ul>	√		√		√	
26	Final gear oil	<ul style="list-style-type: none"> <li>• Check oil level and vehicle for oil leakage.</li> </ul>	√	√		√		
		<ul style="list-style-type: none"> <li>• Change.</li> </ul>	√		√		√	
27	* Front and rear brake switches	<ul style="list-style-type: none"> <li>• Check operation.</li> </ul>	√	√	√	√	√	√
28	Moving parts and cables	<ul style="list-style-type: none"> <li>• Lubricate.</li> </ul>		√	√	√	√	√
29	* Throttle grip	<ul style="list-style-type: none"> <li>• Check operation.</li> <li>• Check throttle grip free play, and adjust if necessary.</li> <li>• Lubricate cable and grip housing.</li> </ul>		√	√	√	√	√
30	* Lights, signals and switches	<ul style="list-style-type: none"> <li>• Check operation.</li> <li>• Adjust headlight beam.</li> </ul>	√	√	√	√	√	√

# Periodic maintenance and adjustment

---

EAU36773

## TIP

---

- Air filter
    - This model's air filter is equipped with a disposable oil-coated paper element, which must not be cleaned with compressed air to avoid damaging it.
    - The air filter element needs to be replaced more frequently when riding in unusually wet or dusty areas.
  - Hydraulic brake and clutch service
    - Regularly check and, if necessary, correct the brake fluid and clutch fluid levels.
    - Every two years replace the internal components of the brake master cylinders and calipers as well as clutch master and release cylinders, and change the brake and clutch fluids.
    - Replace the brake and clutch hoses every four years and if cracked or damaged.
-

## Removing and installing the cowling and panels

EAU18724

The cowling and panels shown need to be removed to perform some of the maintenance jobs described in this chapter. Refer to this section each time the cowling or a panel needs to be removed and installed.

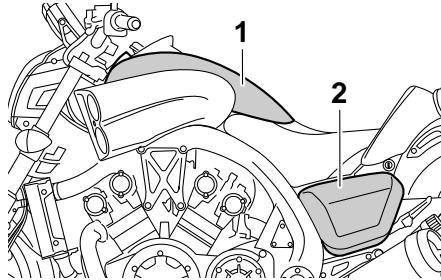

1. Cowling A
2. Panel A

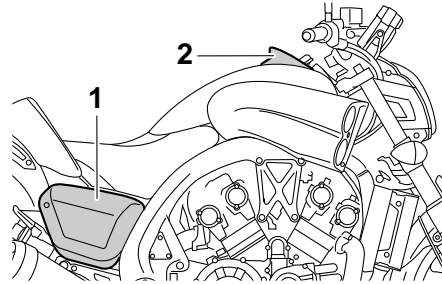

1. Panel B
2. Panel C

### Cowling A

EAU46431

#### To remove the cowling

1. Remove the rider seat. (See page 3-25.)
2. Remove panel C. (See page 6-9.)
3. Remove the bolts, and then pull the cowling off.

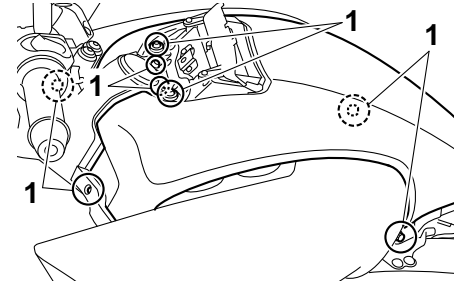

1. Bolt

#### To install the cowling

1. Place the cowling in the original position, and then install the bolts.

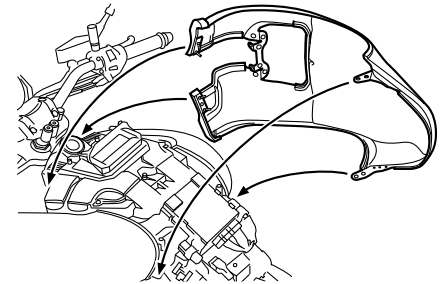

2. Install the panel.
3. Install the rider seat.

# Periodic maintenance and adjustment

EAU46472

## Panel A

### To remove the panel

1. Insert the key into the lock, and then turn it 1/4 turn clockwise.

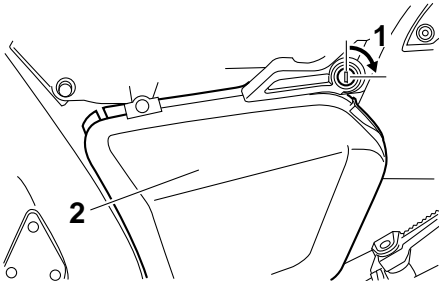

1. Unlock.
2. Panel A

2. Pull the panel outward.

### To install the panel

1. Place the panel in the original position.

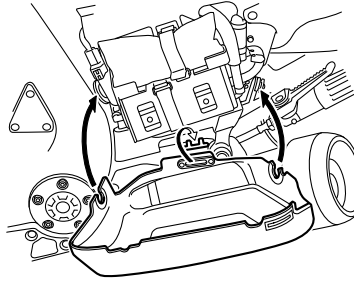

2. Turn the key counterclockwise to the original position, and then remove it.

## Panel B

### To remove the panel

1. Remove the bolt.

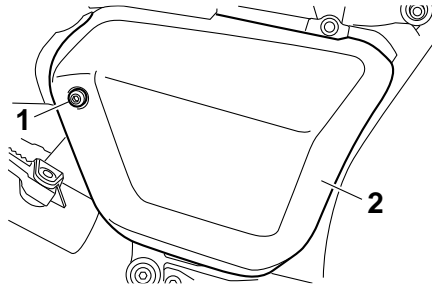

1. Bolt
2. Panel B

2. Pull the panel outward.

### To install the panel

Place the panel in the original position, and then install the bolt.

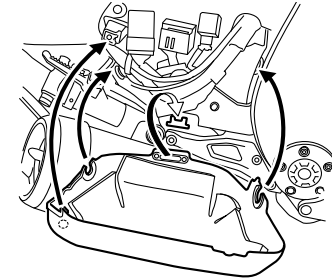

## Panel C

### To remove the panel

1. Remove the bolt.
2. Pull the panel upward.



# Periodic maintenance and adjustment

EAU46681

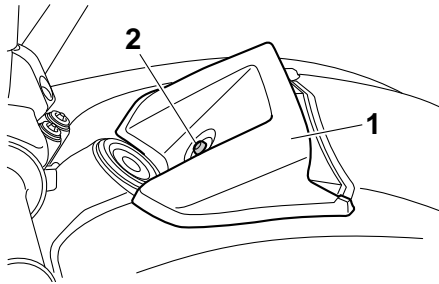

1. Panel C
2. Bolt

## To install the panel

Place the panel in the original position, and then install the bolt.

## Checking the spark plugs

The spark plugs are important engine components, which should be checked periodically, preferably by a Yamaha dealer. Since heat and deposits will cause any spark plug to slowly erode, they should be removed and checked in accordance with the periodic maintenance and lubrication chart. In addition, the condition of the spark plugs can reveal the condition of the engine.

The porcelain insulator around the center electrode of each spark plug should be a medium-to-light tan (the ideal color when the vehicle is ridden normally), and all spark plugs installed in the engine should have the same color. If any spark plug shows a distinctly different color, the engine could be operating improperly. Do not attempt to diagnose such problems yourself. Instead, have a Yamaha dealer check the vehicle.

If a spark plug shows signs of electrode erosion and excessive carbon or other deposits, it should be replaced.

## Specified spark plug:

NGK/CR9EIA  
DENSO/IU27D

Before installing a spark plug, the spark plug gap should be measured with a wire thickness gauge and replaced if out of specification.

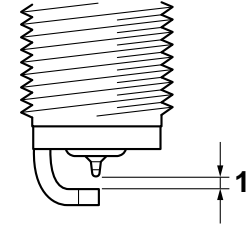

1. Spark plug gap

## Spark plug gap:

0.8–0.9 mm (0.031–0.035 in)

Clean the surface of the spark plug gasket and its mating surface, and then wipe off any grime from the spark plug threads.

# Periodic maintenance and adjustment

## Tightening torque:

Spark plug:  
13 Nm (1.3 m·kgf, 9.4 ft·lbf)

## TIP

If a torque wrench is not available when installing a spark plug, a good estimate of the correct torque is 1/4–1/2 turn past finger tight. However, the spark plug should be tightened to the specified torque as soon as possible.

ECA10841

## NOTICE

Do not use any tools to remove or install the spark plug cap, otherwise the ignition coil coupler may get damaged. The spark plug cap may be difficult to remove because the rubber seal on the end of the cap fits tightly. To remove the spark plug cap, simply twist it back and forth while pulling it out; to install it, twist it back and forth while pushing it in.

## Engine oil and oil filter cartridge

EAU1990A

The engine oil level should be checked before each ride. In addition, the oil must be changed and the oil filter cartridge replaced at the intervals specified in the periodic maintenance and lubrication chart.

### To check the engine oil level

1. Place the vehicle on a level surface and hold it in an upright position. A slight tilt to the side can result in a false reading.
2. Start the engine, warm it up for several minutes, and then turn it off.
3. Wait a few minutes until the oil settles, and then check the oil level through the check window located at the bottom-right side of the crankcase.

## TIP

The engine oil should be between the minimum and maximum level marks.

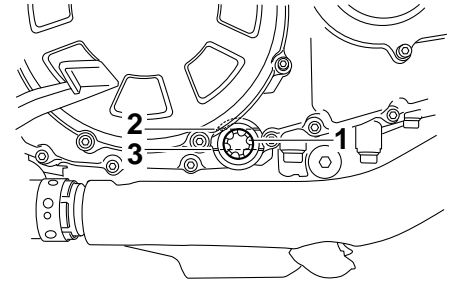

1. Engine oil level check window
2. Maximum level mark
3. Minimum level mark

4. If the engine oil is below the minimum level mark, add sufficient oil of the recommended type to raise it to the correct level.

### To change the engine oil (with or without oil filter cartridge replacement)

1. Place the vehicle on a level surface.
2. Start the engine, warm it up for several minutes, and then turn it off.
3. Place an oil pan under the engine to collect the used oil.

# Periodic maintenance and adjustment

4. Remove the engine oil filler cap, the engine oil drain bolt and its gasket to drain the oil from the crankcase.

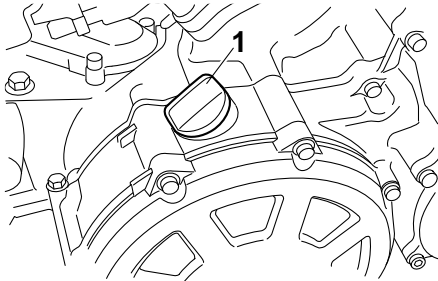

1. Engine oil filler cap

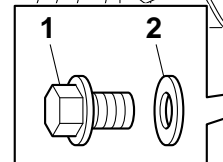
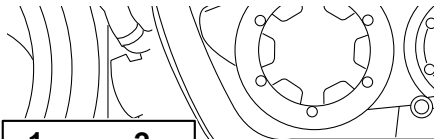

1. Engine oil drain bolt  
2. Gasket

**TIP** \_\_\_\_\_  
Skip steps 5–7 if the oil filter cartridge is not being replaced.

5. Remove the oil filter cartridge with an oil filter wrench.

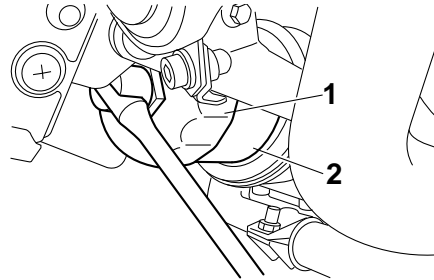

1. Oil filter wrench  
2. Oil filter cartridge

**TIP** \_\_\_\_\_  
An oil filter wrench is available at a Yamaha dealer.

6. Apply a thin coat of clean engine oil to the O-ring of the new oil filter cartridge.

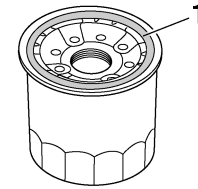

1. O-ring

**TIP** \_\_\_\_\_  
Make sure that the O-ring is properly seated.

7. Install the new oil filter cartridge with an oil filter wrench, and then tighten it to the specified torque with a torque wrench.

# Periodic maintenance and adjustment

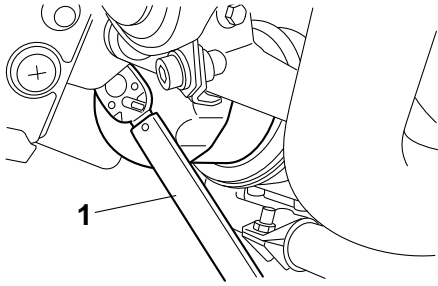

1. Torque wrench

## Tightening torque:

Oil filter cartridge:  
17 Nm (1.7 m·kgf, 12 ft·lbf)

8. Install the engine oil drain bolt and its new gasket, and then tighten the bolt to the specified torque.

## Tightening torque:

Engine oil drain bolt:  
43 Nm (4.3 m·kgf, 31 ft·lbf)

9. Refill with the specified amount of the recommended engine oil, and then install and tighten the oil filler cap.

## Recommended engine oil:

See page 8-1.

## Oil quantity:

Oil change:

4.30 L (4.55 US qt, 3.78 Imp. qt)

With oil filter removal:

4.70 L (4.97 US qt, 4.14 Imp. qt)

## TIP

Be sure to wipe off spilled oil on any parts after the engine and exhaust system have cooled down.

ECA11621

## NOTICE

- In order to prevent clutch slippage (since the engine oil also lubricates the clutch), do not mix any chemical additives. Do not use oils with a diesel specification of “CD” or oils of a higher quality than specified. In addition, do not use oils labeled “ENERGY CONSERVING II” or higher.
- Make sure that no foreign material enters the crankcase.

10. Start the engine, and then let it idle for several minutes while checking it for oil leakage. If oil is leaking, immediately turn the engine off and check for the cause.

## TIP

After the engine is started, the engine oil level warning light should go off if the oil level is sufficient.

ECA10402

## NOTICE

If the oil level warning light flickers or remains on even if the oil level is correct, immediately turn the engine off and have a Yamaha dealer check the vehicle.

11. Turn the engine off, wait a few minutes until the oil settles, and then check the oil level and correct it if necessary.

## Final gear oil

EAU46578

The final gear case must be checked for oil leakage before each ride. If any leakage is found, have a Yamaha dealer check and repair the vehicle. In addition, the final gear oil must be checked and changed as follows at the intervals specified in the periodic maintenance and lubrication chart.

EWA10371

### **WARNING**

- **Make sure that no foreign material enters the final gear case.**
- **Make sure that no oil gets on the tire or wheel.**

### To check the final gear oil level

1. Place the vehicle on a level surface and hold it in an upright position.

### TIP

Make sure that the vehicle is positioned straight up when checking the oil level.

2. Remove the final gear oil check bolt and its gasket, and check that oil flows out.

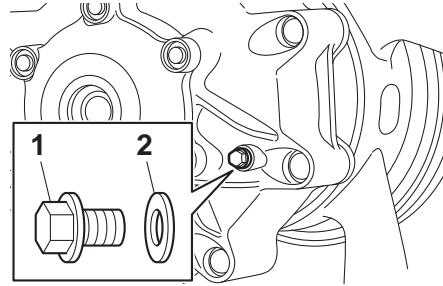

1. Final gear oil check bolt
2. Gasket
3. If no oil flows out, remove the final gear case breather cap by removing the bolt and washer and then remove the final gear oil filler bolt and its gasket.

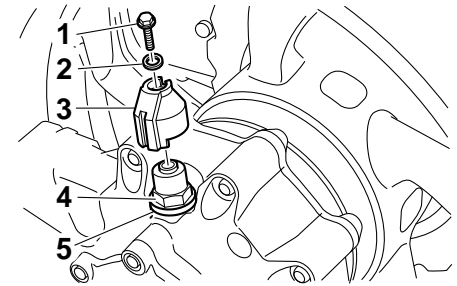

1. Final gear case breather cap bolt
2. Washer
3. Final gear case breather cap
4. Final gear oil filler bolt
5. Gasket
4. Check the gaskets for damage, and replace them if necessary.
5. Pour the recommended type of oil in the final gear oil filler hole until it flows out of the oil check bolt hole.
6. Install the oil check bolt, the oil filler bolt and their gasket, and then tighten the bolts to the specified torques.

### Tightening torques:

- Final gear oil check bolt:  
10 Nm (1.0 m·kgf, 7.2 ft·lbf)
- Final gear oil filler bolt:  
23 Nm (2.3 m·kgf, 17 ft·lbf)

# Periodic maintenance and adjustment

7. Install the final gear case breather cap by installing the washer and bolt, and then tighten the bolt to the specified torque.

## Tightening torque:

Final gear case breather cap bolt:  
10 Nm (1.0 m·kgf, 7.2 ft·lbf)

## To change the final gear oil

1. Place the vehicle on a level surface.
2. Place an oil pan under the final gear case to collect the used oil.
3. Remove the final gear case breather cap by removing the bolt and washer.

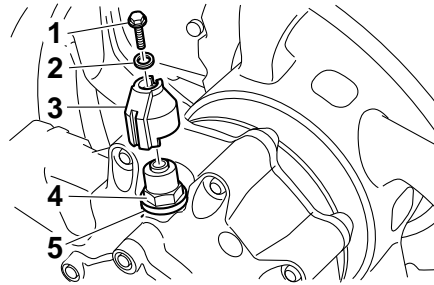

1. Final gear case breather cap bolt
2. Washer
3. Final gear case breather cap
4. Final gear oil filler bolt
5. Gasket

4. Remove the final gear oil filler bolt, the final gear oil drain bolt and their gasket to drain the oil from the final gear case.

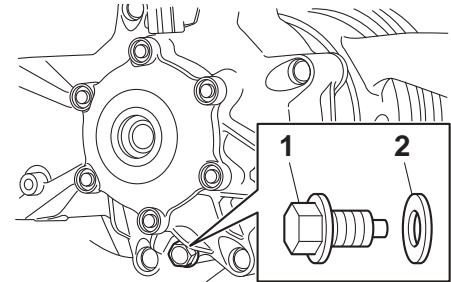

1. Final gear oil drain bolt
2. Gasket

5. Install the drain bolt and its new gasket, and then tighten the bolt to the specified torque.

## Tightening torque:

Final gear oil drain bolt:  
23 Nm (2.3 m·kgf, 17 ft·lbf)

6. Remove the final gear oil check bolt and its gasket.

# Periodic maintenance and adjustment

EAU20071

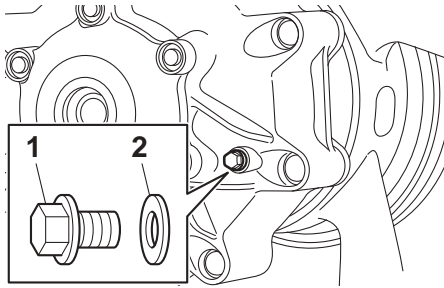

1. Final gear oil check bolt
2. Gasket

7. Check the oil check bolt gasket and the oil filler bolt gasket for damage, and replace them if necessary.
8. Refill with the recommended final gear oil until it flows out of the oil check bolt hole.

## Recommended final gear oil:

Yamaha genuine shaft drive gear oil  
SAE 80W-90 API GL-5

## Oil quantity:

0.30 L (0.32 US qt, 0.26 Imp.qt)

9. Install the oil check bolt, the oil filler bolt and their gasket, and then tighten the bolts to the specified torques.

## Tightening torques:

Final gear oil check bolt:  
10 Nm (1.0 m·kgf, 7.2 ft·lbf)  
Final gear oil filler bolt:  
23 Nm (2.3 m·kgf, 17 ft·lbf)

10. Install the final gear case breather cap by installing the washer and bolt, and then tighten the bolt to the specified torque.

## Tightening torque:

Final gear case breather cap bolt:  
10 Nm (1.0 m·kgf, 7.2 ft·lbf)

11. Check the final gear case for oil leakage. If oil is leaking, check for the cause.

## Coolant

The coolant level should be checked before each ride. In addition, the coolant must be changed at the intervals specified in the periodic maintenance and lubrication chart.

EAU46694

## To check the coolant level

1. Place the vehicle on a level surface and hold it in an upright position.

## TIP

- The coolant level must be checked on a cold engine since the level varies with engine temperature.
- Make sure that the vehicle is positioned straight up when checking the coolant level. A slight tilt to the side can result in a false reading.

2. Check the coolant level in the coolant reservoir.

## TIP

The coolant should be between the minimum and maximum level marks.

# Periodic maintenance and adjustment

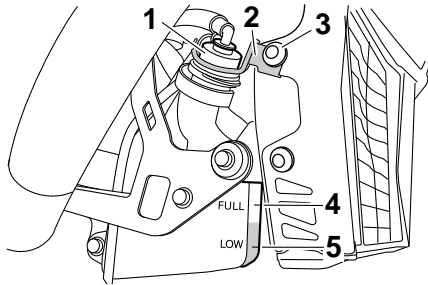

1. Coolant reservoir cap
2. Coolant reservoir cap guard
3. Bolt
4. Maximum level mark
5. Minimum level mark

3. If the coolant is at or below the minimum level mark, remove the coolant reservoir cap guard by removing the bolt, and then remove the reservoir cap. **WARNING! Remove only the coolant reservoir cap. Never attempt to remove the radiator cap when the engine is hot.** [EWA15162]
4. Add coolant to the maximum level mark, and then install the reservoir cap. **NOTICE: If coolant is not available, use distilled water or soft tap water instead. Do not**

use hard water or salt water since it is harmful to the engine. If water has been used instead of coolant, replace it with coolant as soon as possible, otherwise the cooling system will not be protected against frost and corrosion. If water has been added to the coolant, have a Yamaha dealer check the anti-freeze content of the coolant as soon as possible, otherwise the effectiveness of the coolant will be reduced. [ECA10473]

**Coolant reservoir capacity (up to the maximum level mark):**  
0.27 L (0.29 US qt, 0.24 Imp.qt)

5. Install the coolant reservoir cap guard by installing the bolt.

## To change the coolant

1. Place the vehicle on a level surface and let the engine cool if necessary.
2. Remove cowling A. (See page 6-8.)

3. Remove the right air intake duct by removing the bolts.

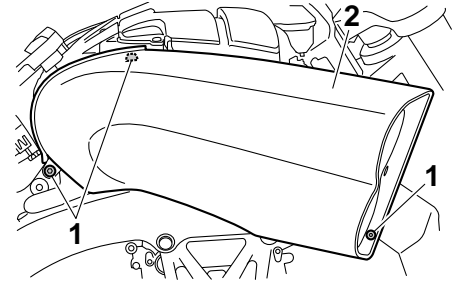

1. Bolt
2. Right air intake duct
4. Place a container under the engine to collect the used coolant.
5. Remove the radiator cap. **WARNING! Never attempt to remove the radiator cap when the engine is hot.** [EWA10382]

EAU46426



# Periodic maintenance and adjustment

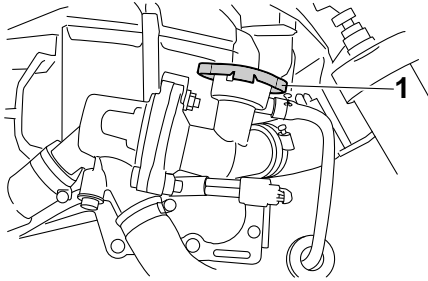

1. Radiator cap

6. Remove the coolant reservoir cover and coolant reservoir by removing the bolts.

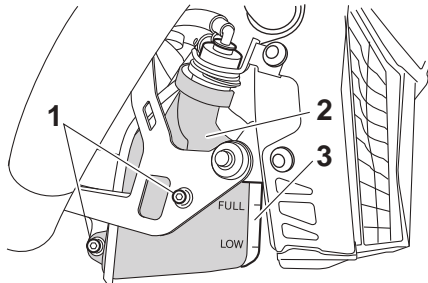

1. Bolt  
2. Coolant reservoir cover  
3. Coolant reservoir

7. Remove the coolant reservoir cap guard by removing the bolt, and then remove the reservoir cap.

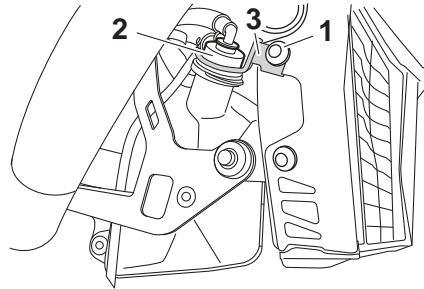

1. Bolt  
2. Coolant reservoir cap  
3. Coolant reservoir cap guard

8. Drain the coolant from the coolant reservoir by turning it upside down.  
9. Install the coolant reservoir cover and the coolant reservoir by placing them in their original position, and then installing the bolts.  
10. Remove the coolant drain screw and its O-ring to drain the cooling system.

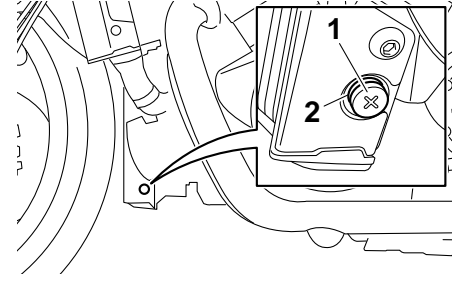

1. Coolant drain screw  
2. O-ring

11. After the coolant is completely drained, thoroughly flush the cooling system with clean tap water.  
12. Install the coolant drain screw and its new O-ring.  
13. Hold the vehicle upright, and pour the specified amount of the recommended coolant into the radiator and reservoir. **NOTICE: Failing to hold the vehicle upright when filling the radiator with coolant may cause air to be trapped in the cooling system.** [ECA16541]

# Periodic maintenance and adjustment

EAU36765

## Antifreeze/water mixture ratio:

1:1

## Recommended antifreeze:

High-quality ethylene glycol antifreeze containing corrosion inhibitors for aluminum engines

## Coolant quantity:

Radiator (including all routes):

3.75 L (3.96 US qt, 3.30 Imp.qt)

Coolant reservoir (up to the maximum level mark):

0.27 L (0.29 US qt, 0.24 Imp.qt)

14. Install the coolant reservoir cap, and then install the reservoir cap guard by installing the bolt.
15. Install the radiator cap.
16. Start the engine, let it idle for several minutes, and then turn it off.
17. Remove the radiator cap to check the coolant level in the radiator. If necessary, add sufficient coolant until it reaches the top of the radiator, and then install the radiator cap.
18. Check the coolant level in the reservoir. If necessary, remove the coolant reservoir cap guard and

the cap, add coolant to the maximum level mark, and then install the cap and the cap guard.

19. Start the engine, and then check the vehicle for coolant leakage. If coolant is leaking, have a Yamaha dealer check the cooling system.
20. Install the right air intake duct by installing the bolts.

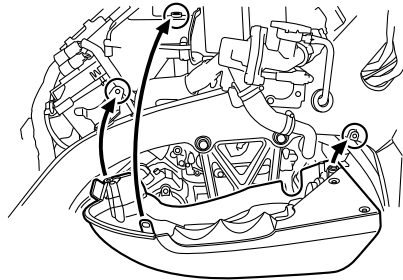

21. Install the cowling.

## Air filter element

The air filter element must be replaced at the intervals specified in the periodic maintenance and lubrication chart. Have a Yamaha dealer replace the air filter element.

## Checking the engine idling speed

EAU44735

Check the engine idling speed and, if necessary, have it corrected by a Yamaha dealer.

**Engine idling speed:**  
950–1050 r/min

## Checking the throttle grip free play

EAU21386

Measure the throttle grip free play as shown.

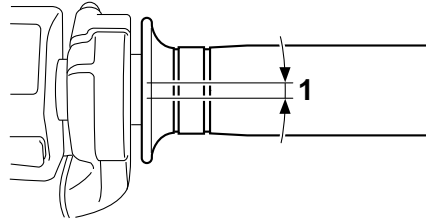

1. Throttle grip free play

**Throttle grip free play:**  
3.0–5.0 mm (0.12–0.20 in)

Periodically check the throttle grip free play and, if necessary, have a Yamaha dealer adjust it.

## Valve clearance

EAU21402

The valve clearance changes with use, resulting in improper air-fuel mixture and/or engine noise. To prevent this from occurring, the valve clearance must be adjusted by a Yamaha dealer at the intervals specified in the periodic maintenance and lubrication chart.

# Periodic maintenance and adjustment

## Tires

EAU64270

Tires are the only contact between the vehicle and the road. Safety in all conditions of riding depends on a relatively small area of road contact. Therefore, it is essential to maintain the tires in good condition at all times and replace them at the appropriate time with the specified tires.

## Tire air pressure

The tire air pressure should be checked and, if necessary, adjusted before each ride.

EWA10504

### **WARNING**

**Operation of this vehicle with improper tire pressure may cause severe injury or death from loss of control.**

- The tire air pressure must be checked and adjusted on cold tires (i.e., when the temperature of the tires equals the ambient temperature).
- The tire air pressure must be adjusted in accordance with the riding speed and with the total

**weight of rider, passenger, cargo, and accessories approved for this model.**

**Tire air pressure (measured on cold tires):**

**Up to 90 kg (198 lb) load:**

Front:

250 kPa (2.50 kgf/cm<sup>2</sup>, 36 psi)

Rear:

290 kPa (2.90 kgf/cm<sup>2</sup>, 42 psi)

**90 kg (198 lb) to maximum load:**

Front:

250 kPa (2.50 kgf/cm<sup>2</sup>, 36 psi)

Rear:

290 kPa (2.90 kgf/cm<sup>2</sup>, 42 psi)

**Maximum load\*:**

190 kg (419 lb)

\* Total weight of rider, passenger, cargo and accessories

EWA10512

### **WARNING**

**Never overload your vehicle. Operation of an overloaded vehicle could cause an accident.**

## Tire inspection

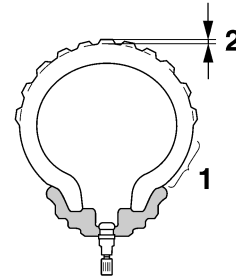

1. Tire sidewall
2. Tire tread depth

The tires must be checked before each ride. If the center tread depth reaches the specified limit, if the tire has a nail or glass fragments in it, or if the sidewall is cracked, have a Yamaha dealer replace the tire immediately.

**Minimum tire tread depth (front and rear):**

1.6 mm (0.06 in)

## TIP

The tire tread depth limits may differ from country to country. Always comply with the local regulations.

# Periodic maintenance and adjustment

EWA10472

## WARNING

- Have a Yamaha dealer replace excessively worn tires. Besides being illegal, operating the vehicle with excessively worn tires decreases riding stability and can lead to loss of control.
- The replacement of all wheel and brake-related parts, including the tires, should be left to a Yamaha dealer, who has the necessary professional knowledge and experience to do so.
- Ride at moderate speeds after changing a tire since the tire surface must first be “broken in” for it to develop its optimal characteristics.

## Tire information

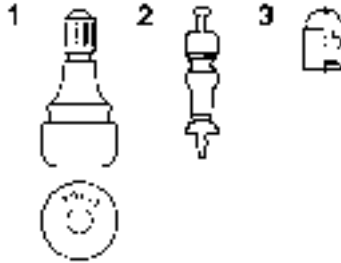

1. Tire air valve
2. Tire air valve core
3. Tire air valve cap with seal

This model is equipped with tubeless tires and tire air valves.

Tires age, even if they have not been used or have only been used occasionally. Cracking of the tread and sidewall rubber, sometimes accompanied by carcass deformation, is an evidence of ageing. Old and aged tires shall be checked by tire specialists to ascertain their suitability for further use.

EWA10902

## WARNING

- The front and rear tires should be of the same make and design, otherwise the handling

characteristics of the motorcycle may be different, which could lead to an accident.

- Always make sure that the valve caps are securely installed to prevent air pressure leakage.
- Use only the tire valves and valve cores listed below to avoid tire deflation during a ride.

After extensive tests, only the tires listed below have been approved for this model by Yamaha.

### Front tire:

Size:

120/70R18M/C 59V

Manufacturer/model:

BRIDGESTONE/BT028F G

### Rear tire:

Size:

200/50R18M/C 76V

Manufacturer/model:

BRIDGESTONE/BT028R G

### FRONT and REAR:

Tire air valve:

TR412

Valve core:

#9100 (original)

# Periodic maintenance and adjustment

---

## WARNING

EWA10601

**This motorcycle is fitted with super-high-speed tires. Note the following points in order to make the most efficient use of these tires.**

- **Use only the specified replacement tires. Other tires may run the danger of bursting at super high speeds.**
  - **Brand-new tires can have a relatively poor grip on certain road surfaces until they have been “broken in”. Therefore, it is advisable before doing any high-speed riding to ride conservatively for approximately 100 km (60 mi) after installing a new tire.**
  - **The tires must be warmed up before a high-speed run.**
  - **Always adjust the tire air pressure according to the operating conditions.**
- 

EAU21963

## Cast wheels

To maximize the performance, durability, and safe operation of your vehicle, note the following points regarding the specified wheels.

- The wheel rims should be checked for cracks, bends, warpage or other damage before each ride. If any damage is found, have a Yamaha dealer replace the wheel. Do not attempt even the smallest repair to the wheel. A deformed or cracked wheel must be replaced.
- The wheel should be balanced whenever either the tire or wheel has been changed or replaced. An unbalanced wheel can result in poor performance, adverse handling characteristics, and a shortened tire life.

EAU42851

## Clutch lever

Since this model is equipped with a hydraulic clutch, adjusting the clutch lever free play is not needed. However, it is necessary to check the hydraulic system for leakage before each ride. If the clutch lever free play does become excessive, and shifting becomes rough or clutch slippage occurs, causing poor acceleration, there may be air in the clutch system. If there is air in the hydraulic system, have a Yamaha dealer bleed the system before operating the motorcycle.

## Checking the brake lever free play

EAU37914

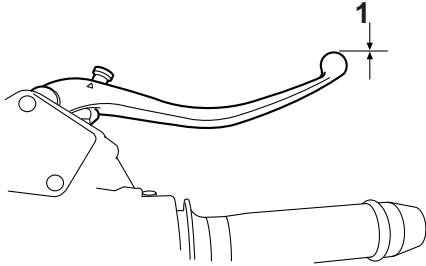

### 1. No brake lever free play

There should be no free play at the brake lever end. If there is free play, have a Yamaha dealer inspect the brake system.

EWA14212

### **! WARNING**

**A soft or spongy feeling in the brake lever can indicate the presence of air in the hydraulic system. If there is air in the hydraulic system, have a Yamaha dealer bleed the system before operating the vehicle. Air in the hydraulic system will diminish the**

**braking performance, which may result in loss of control and an accident.**

---

## Brake light switches

EAU36504

The brake light, which is activated by the brake pedal and brake lever, should come on just before braking takes effect. If necessary, have a Yamaha dealer adjust the brake light switches.

# Periodic maintenance and adjustment

## Checking the front and rear brake pads

EAU22393

The front and rear brake pads must be checked for wear at the intervals specified in the periodic maintenance and lubrication chart.

### Front brake pads

EAU43063

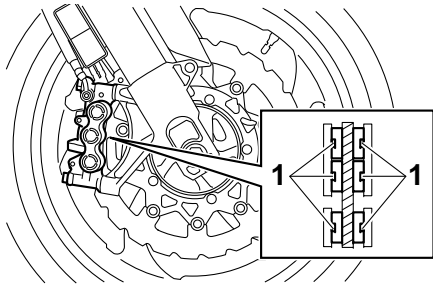

1. Brake pad wear indicator groove

The front brake calipers are equipped with two sets of brake pads.

Each front brake pad is provided with one or two wear indicator grooves, which allow you to check the brake pad wear without having to disassemble the brake. To check the brake pad wear, check the wear indicator grooves. If a brake pad has worn to the

point that a wear indicator groove almost appears, have a Yamaha dealer replace the brake pads as a set.

### Rear brake pads

EAU22471

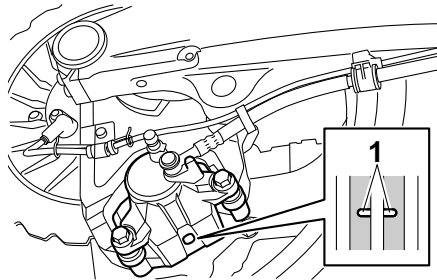

1. Brake pad wear indicator groove

Each rear brake pad is provided with a wear indicator groove, which allows you to check the brake pad wear without having to disassemble the brake. To check the brake pad wear, check the wear indicator groove. If a brake pad has worn to the point that the wear indicator groove has almost disappeared, have a Yamaha dealer replace the brake pads as a set.

## Checking the brake fluid level

EAU46542

Before riding, check that the brake fluid is above the minimum level mark. Check the brake fluid level with the top of the reservoir level. Replenish the brake fluid if necessary.

### Front brake

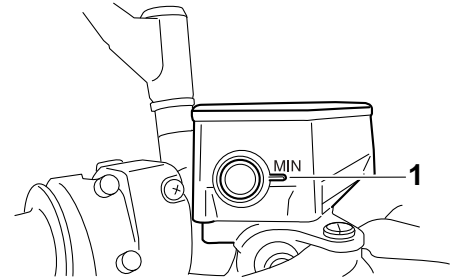

1. Minimum level mark



# Periodic maintenance and adjustment

## Rear brake

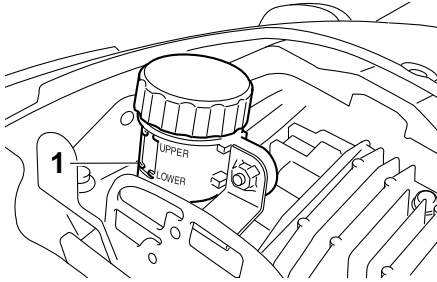

1. Minimum level mark

### TIP \_\_\_\_\_

The rear brake fluid reservoir is located under the passenger seat. (See page 3-25.)

**Specified brake fluid:**  
DOT 4

EWA16011

### **WARNING** \_\_\_\_\_

Improper maintenance can result in loss of braking ability. Observe these precautions:

- **Insufficient brake fluid may allow air to enter the brake system, reducing braking performance.**

- **Clean the filler cap before removing. Use only DOT 4 brake fluid from a sealed container.**
- **Use only the specified brake fluid; otherwise, the rubber seals may deteriorate, causing leakage.**
- **Refill with the same type of brake fluid. Adding a brake fluid other than DOT 4 may result in a harmful chemical reaction.**
- **Be careful that water or dust does not enter the brake fluid reservoir when refilling. Water will significantly lower the boiling point of the fluid and may result in vapor lock, and dirt may clog the ABS hydraulic unit valves.**

system leakage; therefore, be sure to check the brake pads for wear and the brake system for leakage. If the brake fluid level goes down suddenly, have a Yamaha dealer check the cause before further riding.

### **NOTICE** \_\_\_\_\_

**Brake fluid may damage painted surfaces or plastic parts. Always clean up spilled fluid immediately.**

As the brake pads wear, it is normal for the brake fluid level to gradually go down. A low brake fluid level may indicate worn brake pads and/or brake

# Periodic maintenance and adjustment

6

## Changing the brake and clutch fluids

EAU22754

Have a Yamaha dealer change the brake and clutch fluids at the intervals specified in the periodic maintenance and lubrication chart. In addition, have the oil seals of the brake and clutch master cylinders and calipers as well as the brake and clutch hoses replaced at the intervals listed below or whenever they are damaged or leaking.

- Oil seals: Replace every two years.
- Brake and clutch hoses: Replace every four years.

## Checking and lubricating the cables

EAU23098

The operation of all control cables and the condition of the cables should be checked before each ride, and the cables and cable ends should be lubricated if necessary. If a cable is damaged or does not move smoothly, have a Yamaha dealer check or replace it. **WARNING! Damage to the outer housing of cables may result in internal rusting and cause interference with cable movement. Replace damaged cables as soon as possible to prevent unsafe conditions.** [EWA10712]

**Recommended lubricant:**  
Yamaha cable lubricant or other suitable cable lubricant

## Checking and lubricating the throttle grip and cable

EAU23115

The operation of the throttle grip should be checked before each ride. In addition, the cable should be lubricated by a Yamaha dealer at the intervals specified in the periodic maintenance chart.

The throttle cable is equipped with a rubber cover. Make sure that the cover is securely installed. Even though the cover is installed correctly, it does not completely protect the cable from water entry. Therefore, use care not to pour water directly onto the cover or cable when washing the vehicle. If the cable or cover becomes dirty, wipe clean with a moist cloth.

# Periodic maintenance and adjustment

## Checking and lubricating the brake and shift pedals EAU44276

The operation of the brake and shift pedals should be checked before each ride, and the pedal pivots should be lubricated if necessary.

### Brake pedal

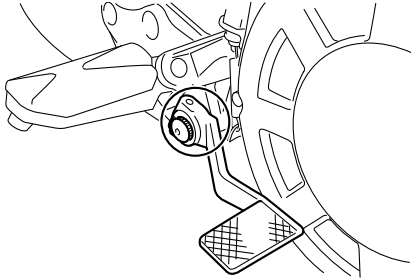

### Shift pedal

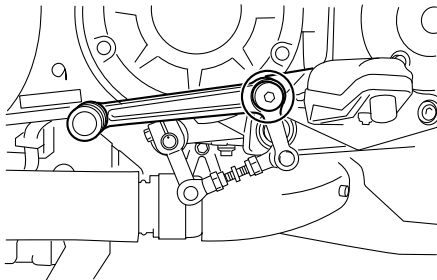

**Recommended lubricant:**  
Lithium-soap-based grease

## Checking and lubricating the brake and clutch levers EAU43602

The operation of the brake and clutch levers should be checked before each ride, and the lever pivots should be lubricated if necessary.

### Brake lever

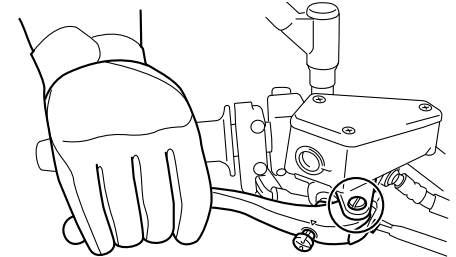

### Clutch lever

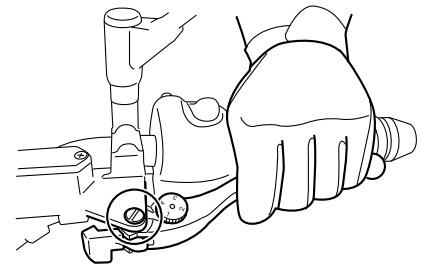

# Periodic maintenance and adjustment

**Recommended lubricant:**  
Silicone grease

## Checking and lubricating the sidestand EAU23203

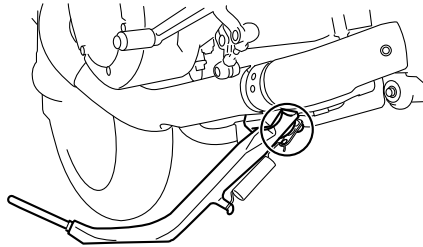

The operation of the sidestand should be checked before each ride, and the sidestand pivot and metal-to-metal contact surfaces should be lubricated if necessary.

### **WARNING**

EWA10732

**If the sidestand does not move up and down smoothly, have a Yamaha dealer check or repair it. Otherwise, the sidestand could contact the ground and distract the operator, resulting in a possible loss of control.**

**Recommended lubricant:**  
Lithium-soap-based grease

## Lubricating the swingarm pivots EAUM1653

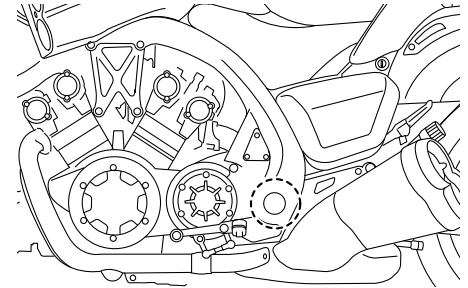

The swingarm pivots must be lubricated by a Yamaha dealer at the intervals specified in the periodic maintenance and lubrication chart.

**Recommended lubricant:**  
Lithium-soap-based grease

EAU23273

## Checking the front fork

The condition and operation of the front fork must be checked as follows at the intervals specified in the periodic maintenance and lubrication chart.

### To check the condition

Check the inner tubes for scratches, damage and excessive oil leakage.

### To check the operation

1. Place the vehicle on a level surface and hold it in an upright position. **WARNING! To avoid injury, securely support the vehicle so there is no danger of it falling over.** [EWA10752]
2. While applying the front brake, push down hard on the handlebars several times to check if the front fork compresses and rebounds smoothly.

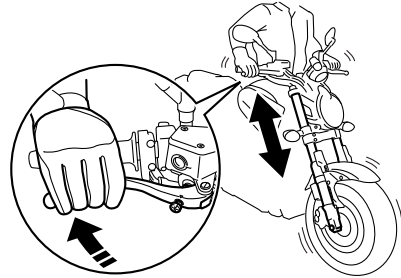

ECA10591

### NOTICE

**If any damage is found or the front fork does not operate smoothly, have a Yamaha dealer check or repair it.**

EAU23285

## Checking the steering

Worn or loose steering bearings may cause danger. Therefore, the operation of the steering must be checked as follows at the intervals specified in the periodic maintenance and lubrication chart.

1. Raise the front wheel off the ground. (See page 6-39.) **WARNING! To avoid injury, securely support the vehicle so there is no danger of it falling over.** [EWA10752]
2. Hold the lower ends of the front fork legs and try to move them forward and backward. If any free play can be felt, have a Yamaha dealer check or repair the steering.

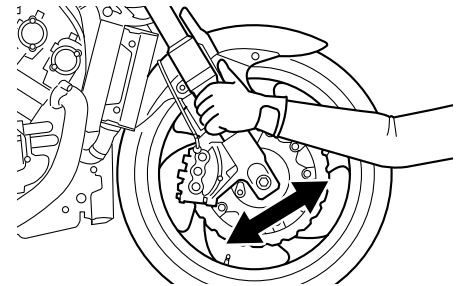

# Periodic maintenance and adjustment

## Checking the wheel bearings

EAU23292

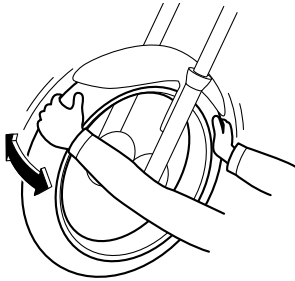

The front and rear wheel bearings must be checked at the intervals specified in the periodic maintenance and lubrication chart. If there is play in the wheel hub or if the wheel does not turn smoothly, have a Yamaha dealer check the wheel bearings.

6

## Battery

EAU46556

The battery is located under cowling A. (See page 6-8.)

This model is equipped with a VRLA (Valve Regulated Lead Acid) battery. There is no need to check the electrolyte or to add distilled water. However, the battery lead connections need to be checked and, if necessary, tightened.

EWA10761

### WARNING

- **Electrolyte is poisonous and dangerous since it contains sulfuric acid, which causes severe burns. Avoid any contact with skin, eyes or clothing and always shield your eyes when working near batteries. In case of contact, administer the following FIRST AID.**
  - **EXTERNAL:** Flush with plenty of water.
  - **INTERNAL:** Drink large quantities of water or milk and immediately call a physician.

- **EYES:** Flush with water for 15 minutes and seek prompt medical attention.
- **Batteries produce explosive hydrogen gas. Therefore, keep sparks, flames, cigarettes, etc., away from the battery and provide sufficient ventilation when charging it in an enclosed space.**
- **KEEP THIS AND ALL BATTERIES OUT OF THE REACH OF CHILDREN.**

### To remove the battery

1. Remove cowling A. (See page 6-8.)
2. Disconnect the negative battery lead first, then the positive battery lead by removing their bolt.  
**NOTICE:** When removing the battery, be sure the key is turned to “OFF”, then disconnect the negative lead before disconnecting the positive lead.

[ECA16303]

# Periodic maintenance and adjustment

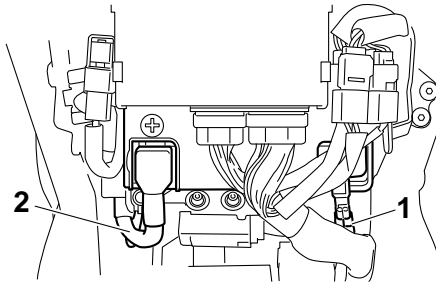

1. Negative battery lead (black)
2. Positive battery lead (red)

3. Remove the battery cover bolts, lift the battery cover (together with the ECU), then move the cover to the side.

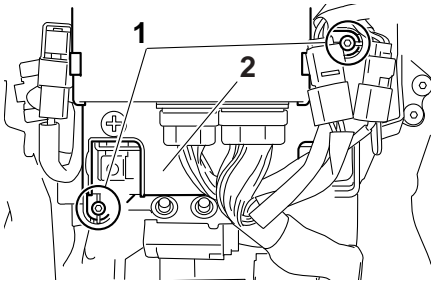

1. Battery cover bolt
2. Battery cover

4. Remove the main fuse (together with the holding band) from its holder.
5. Disconnect coupler A.

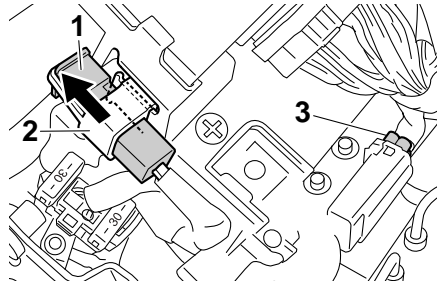

1. Main fuse
2. Holding band
3. Coupler A

6. Remove the rubber damper.

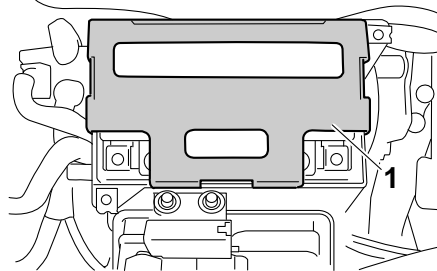

1. Rubber damper

7. Unfold the heat insulator as shown.

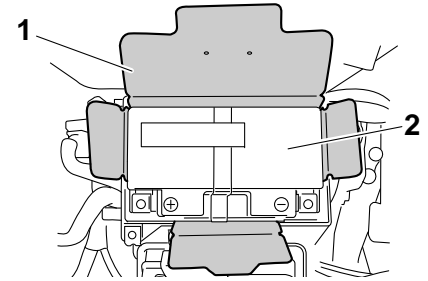

1. Heat insulator
2. Battery

8. Pull the battery out of its compartment.

## To charge the battery

Have a Yamaha dealer charge the battery as soon as possible if it seems to have discharged. Keep in mind that the battery tends to discharge more quickly if the vehicle is equipped with optional electrical accessories.

# Periodic maintenance and adjustment

ECA16522

## NOTICE

To charge a VRLA (Valve Regulated Lead Acid) battery, a special (constant-voltage) battery charger is required. Using a conventional battery charger will damage the battery.

## To store the battery

1. If the vehicle will not be used for more than one month, remove the battery, fully charge it, and then place it in a cool, dry place. **NOTICE:** When removing the battery, be sure the key is turned to “OFF”, then disconnect the negative lead before disconnecting the positive lead.

[ECA16303]

2. If the battery will be stored for more than two months, check it at least once a month and fully charge it if necessary.

## To install the battery

### TIP

Be sure the battery is fully charged.

1. Place the battery in its compartment.
2. Fold the heat insulator back to its original position. **NOTICE:** Make sure that the heat insulator is in its original position and it is properly folded. [ECA16551]

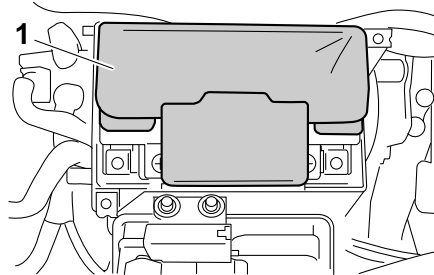

1. Heat insulator
3. Install the rubber damper.
4. Connect coupler A.
5. Install the main fuse (together with the holding band) on its holder.
6. Place the battery cover (together with the ECU) in the original position, and then install the bolts.
7. Connect the positive battery lead first, then connect the negative battery lead by installing their bolt. **NOTICE:** When installing the

battery, be sure the key is turned to “OFF”, then connect the positive lead before connecting the negative lead. [ECA16841]

8. Install the cowl.

ECA16531

## NOTICE

Always keep the battery charged. Storing a discharged battery can cause permanent battery damage.



EAU46456

## Replacing the fuses

The main fuse and the ABS motor fuse are located behind cowling A. (See page 6-8.)

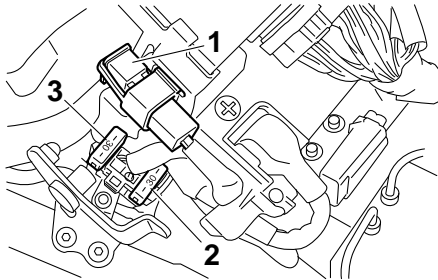

1. Main fuse
2. ABS motor fuse
3. ABS motor spare fuse

Fuse box 1 is located under the rider seat. (See page 3-25.)

## Fuse box 1

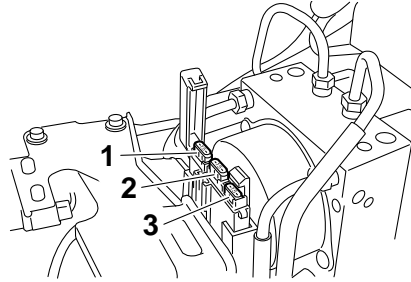

1. ABS solenoid fuse
2. Fuel injection system fuse
3. Spare fuse

Fuse box 2 is located behind panel B. (See page 6-8.)

## Fuse box 2

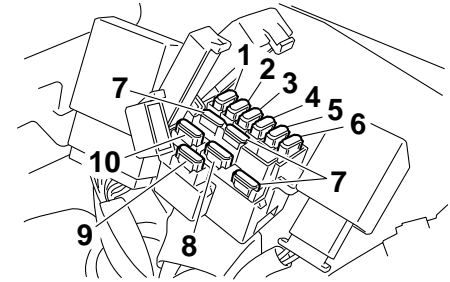

1. Ignition fuse
2. ABS control unit fuse
3. Headlight fuse
4. Backup fuse (for clock and immobilizer system)
5. Electronic throttle valve fuse
6. Radiator fan motor fuse
7. Spare fuse
8. Signaling system fuse
9. Parking lighting fuse
10. Sub radiator fan motor fuse

If a fuse is blown, replace it as follows.

1. Turn the key to "OFF" and turn off the electrical circuit in question.
2. Remove the blown fuse, and then install a new fuse of the specified amperage. **WARNING! Do not use a fuse of a higher amperage rating than recommended to**

# Periodic maintenance and adjustment

**avoid causing extensive damage to the electrical system and possibly a fire.** [EWA15132]

## Specified fuses:

- Main fuse:  
50.0 A
- Ignition fuse:  
20.0 A
- Parking lighting fuse:  
7.5 A
- Signaling system fuse:  
7.5 A
- Headlight fuse:  
15.0 A
- Radiator fan motor fuse:  
20.0 A
- Sub radiator fan motor fuse:  
7.5 A
- Fuel injection system fuse:  
15.0 A
- ABS control unit fuse:  
7.5 A
- ABS motor fuse:  
30.0 A
- ABS solenoid fuse:  
15.0 A
- Backup fuse:  
7.5 A
- Electronic throttle valve fuse:  
7.5 A

3. Turn the key to “ON” and turn on the electrical circuit in question to check if the device operates.
4. If the fuse immediately blows again, have a Yamaha dealer check the electrical system.

EAU46463

## Replacing the headlight bulb

This model is equipped with a halogen bulb headlight. If the headlight bulb burns out, replace it as follows.

ECA10651

### NOTICE

**Take care not to damage the following parts:**

- **Headlight bulb**

**Do not touch the glass part of the headlight bulb to keep it free from oil, otherwise the transparency of the glass, the luminosity of the bulb, and the bulb life will be adversely affected. Thoroughly clean off any dirt and fingerprints on the headlight bulb using a cloth moistened with alcohol or thinner.**

- **Headlight lens**

**Do not affix any type of tinted film or stickers to the headlight lens.**

**Do not use a headlight bulb of a wattage higher than specified.**

# Periodic maintenance and adjustment

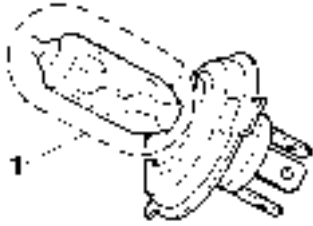

1. Do not touch the glass part of the bulb.

1. Remove the headlight unit by removing the bolts.

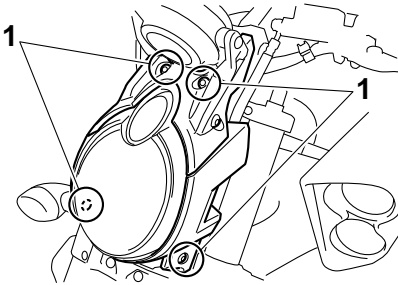

1. Bolt

2. Disconnect the headlight coupler, and then remove the bulb cover.

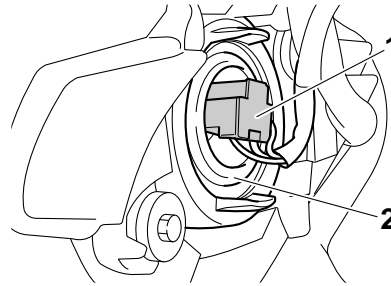

1. Headlight coupler  
2. Headlight bulb cover

3. Unhook the headlight bulb holder, and then remove the burnt-out bulb.

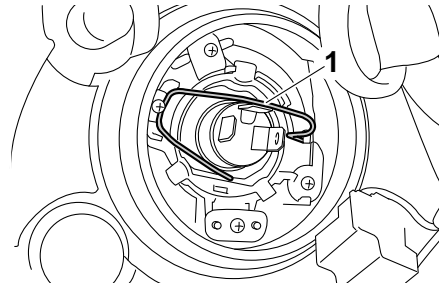

1. Headlight bulb holder

4. Place a new headlight bulb into position, and then secure it with the bulb holder.

5. Install the headlight bulb cover, and then connect the coupler.
6. Install the headlight unit by installing the bolts.
7. Have a Yamaha dealer adjust the headlight beam if necessary.

# Periodic maintenance and adjustment

EAU46405

## Replacing the auxiliary light bulb

If the auxiliary light bulb burns out, replace it as follows.

1. Remove the headlight unit. (See page 6-35.)
2. Remove the auxiliary light bulb socket (together with the bulb) by turning it counterclockwise.

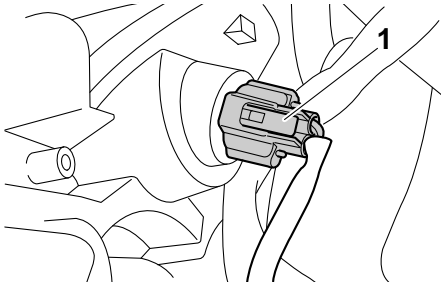

1. Auxiliary light bulb socket

3. Remove the burnt-out bulb by pulling it out of the socket.

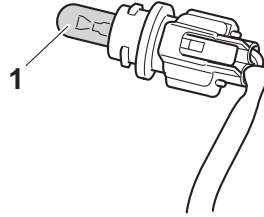

1. Auxiliary light bulb

4. Insert a new bulb into the socket.
5. Install the socket (together with the bulb) by turning it clockwise.
6. Install the headlight unit.

EAU70540

## Brake/tail light

This model is equipped with an LED-type brake/tail light.

If the brake/tail light does not come on, have a Yamaha dealer check it.

## Replacing a turn signal light bulb

EAU24205

1. Remove the turn signal light lens by removing the screw.

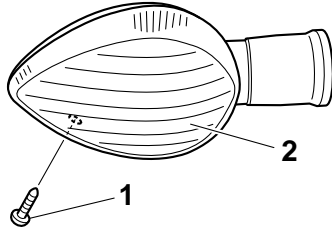

1. Screw
2. Turn signal light lens

2. Remove the burnt-out bulb by pushing it in and turning it counterclockwise.

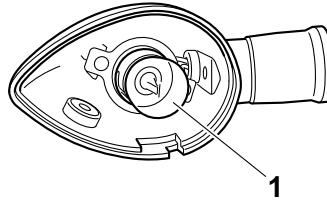

1. Turn signal light bulb
3. Insert a new bulb into the socket, push it in, and then turn it clockwise until it stops.
4. Install the lens by installing the screw. **NOTICE: Do not overtighten the screw, otherwise the lens may break.** [ECA11192]

## Replacing a license plate light bulb

EAU50453

1. Remove the holding plate by removing the bolts.

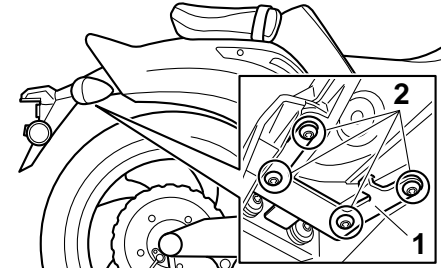

1. Holding plate
2. Bolt

2. Remove the license plate light unit bolts.

# Periodic maintenance and adjustment

EAU24351

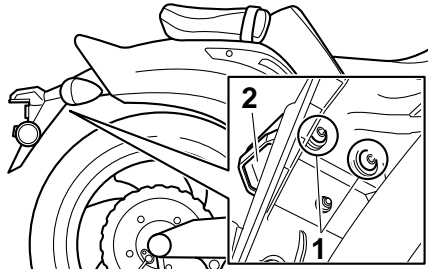

1. License plate light unit bolt
2. License plate light unit

3. Pull the license plate light unit outward as shown to access the bulb and its socket.

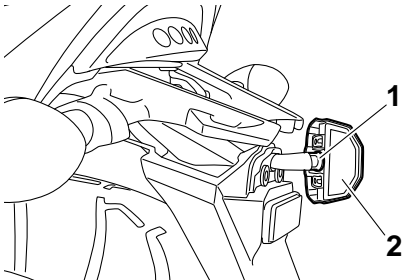

1. License plate light bulb socket
2. License plate light unit

4. Remove the license plate light bulb socket (together with the bulb) by turning it counterclockwise, and then pulling it out.
5. Remove the burnt-out bulb by pulling it out.

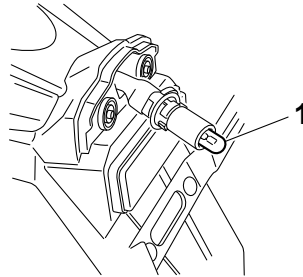

1. License plate light bulb

6. Insert a new bulb into the socket.
7. Install the socket (together with the bulb) by pushing it in, and then turning it clockwise until it stops.
8. Place the license plate light unit in the original position, and then install the bolts.
9. Install the holding plate by installing the bolts.

## Supporting the motorcycle

Since this model is not equipped with a centerstand, follow these precautions when removing the front and rear wheel or performing other maintenance requiring the motorcycle to stand upright. Check that the motorcycle is in a stable and level position before starting any maintenance. A strong wooden box can be placed under the engine for added stability.

### To service the front wheel

1. Stabilize the rear of the motorcycle by using a motorcycle stand or, if an additional motorcycle stand is not available, by placing a jack under the frame in front of the rear wheel.
2. Raise the front wheel off the ground by using a motorcycle stand.

### To service the rear wheel

Raise the rear wheel off the ground by using a motorcycle stand or, if a motorcycle stand is not available, by placing

# Periodic maintenance and adjustment

a jack either under each side of the frame in front of the rear wheel or under each side of the swingarm.

## Troubleshooting

EAU25872

Although Yamaha motorcycles receive a thorough inspection before shipment from the factory, trouble may occur during operation. Any problem in the fuel, compression, or ignition systems, for example, can cause poor starting and loss of power.

The following troubleshooting charts represent quick and easy procedures for checking these vital systems yourself. However, should your motorcycle require any repair, take it to a Yamaha dealer, whose skilled technicians have the necessary tools, experience, and know-how to service the motorcycle properly.

Use only genuine Yamaha replacement parts. Imitation parts may look like Yamaha parts, but they are often inferior, have a shorter service life and can lead to expensive repair bills.

EWA15142

### **WARNING**

**When checking the fuel system, do not smoke, and make sure there are no open flames or sparks in the area, including pilot lights from water**

**heaters or furnaces. Gasoline or gasoline vapors can ignite or explode, causing severe injury or property damage.**

# Periodic maintenance and adjustment

EAU63200

## Troubleshooting charts

### Starting problems or poor engine performance

#### 1. Fuel

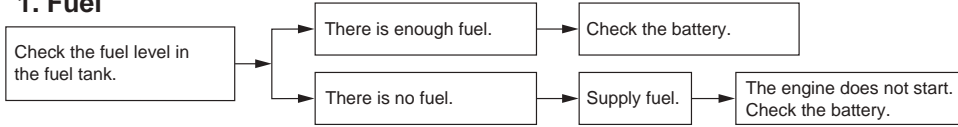

#### 2. Battery

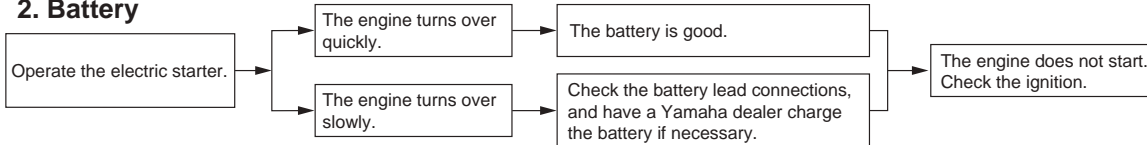

#### 3. Ignition

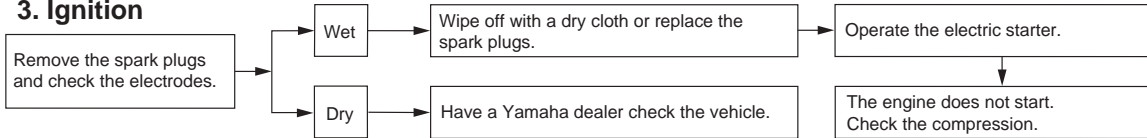

#### 4. Compression

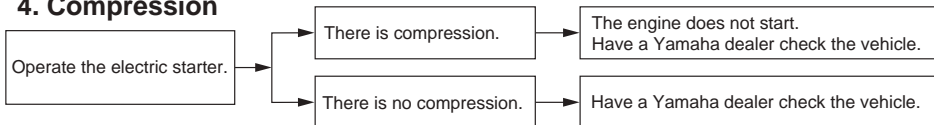



# Periodic maintenance and adjustment

## Engine overheating

EWAT1041

### WARNING

- Do not remove the radiator cap when the engine and radiator are hot. Scalding hot fluid and steam may be blown out under pressure, which could cause serious injury. Be sure to wait until the engine has cooled.
- Place a thick rag, like a towel, over the radiator cap, and then slowly rotate the cap counterclockwise to the detent to allow any residual pressure to escape. When the hissing sound has stopped, press down on the cap while turning it counterclockwise, and then remove the cap.

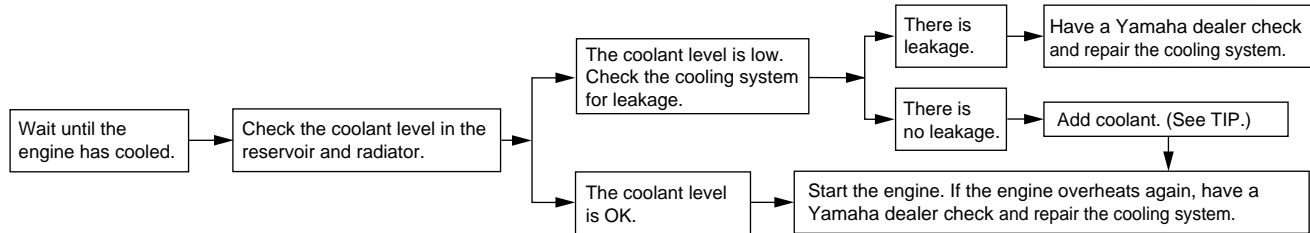

### TIP

If coolant is not available, tap water can be temporarily used instead, provided that it is changed to the recommended coolant as soon as possible.

# Motorcycle care and storage

---

## Matte color caution

EAU37834

ECA15193

### NOTICE

Some models are equipped with matte colored finished parts. Be sure to consult a Yamaha dealer for advice on what products to use before cleaning the vehicle. Using a brush, harsh chemical products or cleaning compounds when cleaning these parts will scratch or damage their surface. Wax also should not be applied to any matte colored finished parts.

---

7

## Care

EAU46411

While the open design of a motorcycle reveals the attractiveness of the technology, it also makes it more vulnerable. Rust and corrosion can develop even if high-quality components are used. A rusty exhaust pipe may go unnoticed on a car, however, it detracts from the overall appearance of a motorcycle. Frequent and proper care does not only comply with the terms of the warranty, but it will also keep your motorcycle looking good, extend its life and optimize its performance.

## Before cleaning

1. Cover the muffler outlets with a plastic bag after the engine has cooled down.
2. Make sure that all caps and covers as well as all electrical couplers and connectors, including the spark plug caps, are tightly installed.
3. Remove extremely stubborn dirt, like oil burnt onto the crankcase, with a degreasing agent and a brush, but never apply such prod-

ucts onto seals, gaskets and wheel axles. Always rinse the dirt and degreaser off with water.

## Cleaning

ECA10773

### NOTICE

- **Avoid using strong acidic wheel cleaners, especially on spoked wheels. If such products are used on hard-to-remove dirt, do not leave the cleaner on the affected area any longer than instructed. Also, thoroughly rinse the area off with water, immediately dry it, and then apply a corrosion protection spray.**
- **Improper cleaning can damage plastic parts (such as cowlings, panels, windshields, headlight lenses, meter lenses, etc.) and the mufflers. Use only a soft, clean cloth or sponge with water to clean plastic. However, if the plastic parts cannot be thoroughly cleaned with water, diluted mild detergent with water may be used. Be sure to rinse**

off any detergent residue using plenty of water, as it is harmful to plastic parts.

- Do not use any harsh chemical products on plastic parts. Be sure to avoid using cloths or sponges which have been in contact with strong or abrasive cleaning products, solvent or thinner, fuel (gasoline), rust removers or inhibitors, brake fluid, antifreeze or electrolyte.
- Do not use high-pressure washers or steam-jet cleaners since they cause water seepage and deterioration in the following areas: seals (of wheel and swing-arm bearings, fork and brakes), electric components (couplers, connectors, instruments, switches and lights), breather hoses and vents.
- For motorcycles equipped with a windshield: Do not use strong cleaners or hard sponges as they will cause dulling or scratching. Some cleaning compounds for plastic may leave scratches on the wind-

shield. Test the product on a small hidden part of the windshield to make sure that it does not leave any marks. If the windshield is scratched, use a quality plastic polishing compound after washing.

#### After normal use

Remove dirt with warm water, a mild detergent, and a soft, clean sponge, and then rinse thoroughly with clean water. Use a toothbrush or bottlebrush for hard-to-reach areas. Stubborn dirt and insects will come off more easily if the area is covered with a wet cloth for a few minutes before cleaning.

#### After riding in the rain, near the sea or on salt-sprayed roads

Since sea salt or salt sprayed on roads during winter are extremely corrosive in combination with water, carry out the following steps after each ride in the rain, near the sea or on salt-sprayed roads.

#### TIP

Salt sprayed on roads in the winter may remain well into spring.

1. Clean the motorcycle with cold water and a mild detergent, after the engine has cooled down. **NOTICE: Do not use warm water since it increases the corrosive action of the salt.** [ECA10792]
2. After drying the motorcycle, apply a corrosion protection spray on all metal, including chrome- and nickel-plated, surfaces (except the titanium mufflers) to prevent corrosion.

#### Cleaning the titanium mufflers

This model is equipped with titanium mufflers, which require the following special care.

- Use only a soft, clean cloth or sponge with mild detergent and water to clean the titanium mufflers. However, if the mufflers cannot be thoroughly cleaned with mild detergent, alkaline products and a soft brush may be used.

# Motorcycle care and storage

---

- Never use compounds or other special treatments to clean the titanium mufflers, as they will remove the finish on the outer surface of the mufflers.
  - Even the smallest amounts of oil, such as from oily towels or fingerprints, will leave stains on the titanium mufflers, which can be removed with a mild detergent.
  - Note that the thermally induced discoloring of the portion of the exhaust pipe leading into the titanium mufflers is normal and cannot be removed.
4. To prevent corrosion, it is recommended to apply a corrosion protection spray on all metal, including chrome- and nickel-plated, surfaces.
  5. Use spray oil as a universal cleaner to remove any remaining dirt.
  6. Touch up minor paint damage caused by stones, etc.
  7. Wax all painted surfaces.
  8. Let the motorcycle dry completely before storing or covering it.

EWA11132

## **WARNING**

**Contaminants on the brakes or tires can cause loss of control.**

- **Make sure that there is no oil or wax on the brakes or tires.**
  - **If necessary, clean the brake discs and brake linings with a regular brake disc cleaner or acetone, and wash the tires with warm water and a mild detergent. Before riding at higher speeds, test the motorcycle's braking performance and cornering behavior.**
- 

ECA10801

## **NOTICE**

- **Apply spray oil and wax sparingly and make sure to wipe off any excess.**
  - **Never apply oil or wax to any rubber and plastic parts, but treat them with a suitable care product.**
  - **Avoid using abrasive polishing compounds as they will wear away the paint.**
- 

## **TIP**

- Consult a Yamaha dealer for advice on what products to use.
  - Washing, rainy weather or humid climates can cause the headlight lens to fog. Turning the headlight on for a short period of time will help remove the moisture from the lens.
- 

## **After cleaning**

1. Dry the motorcycle with a chamois or an absorbing cloth.
2. Immediately dry the drive chain and lubricate it to prevent it from rusting.
3. Use a chrome polish to shine chrome, aluminum and stainless-steel parts.

## Storage

EAU26244

### Short-term

Always store your motorcycle in a cool, dry place and, if necessary, protect it against dust with a porous cover. Be sure the engine and the exhaust system are cool before covering the motorcycle.

ECA10811

### NOTICE

- **Storing the motorcycle in a poorly ventilated room or covering it with a tarp, while it is still wet, will allow water and humidity to seep in and cause rust.**
- **To prevent corrosion, avoid damp cellars, stables (because of the presence of ammonia) and areas where strong chemicals are stored.**

### Long-term

Before storing your motorcycle for several months:

1. Follow all the instructions in the “Care” section of this chapter.

2. Fill up the fuel tank and add fuel stabilizer (if available) to prevent the fuel tank from rusting and the fuel from deteriorating.
3. Perform the following steps to protect the cylinders, piston rings, etc. from corrosion.
  - a. Remove the spark plug caps and spark plugs.
  - b. Pour a teaspoonful of engine oil into each spark plug bore.
  - c. Install the spark plug caps onto the spark plugs, and then place the spark plugs on the cylinder head so that the electrodes are grounded. (This will limit sparking during the next step.)
  - d. Turn the engine over several times with the starter. (This will coat the cylinder walls with oil.)  
**WARNING! To prevent damage or injury from sparking, make sure to ground the spark plug electrodes while turning the engine over.**
- e. Remove the spark plug caps from the spark plugs, and then install the spark plugs and the spark plug caps.
4. Lubricate all control cables and the pivoting points of all levers and pedals as well as of the side-stand/centerstand.
5. Check and, if necessary, correct the tire air pressure, and then lift the motorcycle so that both of its wheels are off the ground. Alternatively, turn the wheels a little every month in order to prevent the tires from becoming degraded in one spot.
6. Cover the muffler outlets with plastic bags to prevent moisture from entering them.
7. Remove the battery and fully charge it. Store it in a cool, dry place and charge it once a month. Do not store the battery in an excessively cold or warm place [less than 0 °C (30 °F) or more than 30 °C (90 °F)]. For more information on storing the battery, see page 6-31.

[EWA10952]

# Motorcycle care and storage

---

## TIP \_\_\_\_\_

Make any necessary repairs before storing the motorcycle.

---

## Dimensions:

- Overall length:  
2395 mm (94.3 in)
- Overall width:  
820 mm (32.3 in)
- Overall height:  
1190 mm (46.9 in)
- Seat height:  
775 mm (30.5 in)
- Wheelbase:  
1700 mm (66.9 in)
- Ground clearance:  
140 mm (5.51 in)
- Minimum turning radius:  
3.5 m (11.48 ft)

## Weight:

- Curb weight:  
310 kg (683 lb)

## Engine:

- Combustion cycle:  
4-stroke
- Cooling system:  
Liquid cooled
- Valve train:  
DOHC
- Cylinder arrangement:  
V-type
- Number of cylinders:  
4-cylinder
- Displacement:  
1679 cm<sup>3</sup>
- Bore × stroke:  
90.0 × 66.0 mm (3.54 × 2.60 in)

## Compression ratio:

11.3 : 1

## Starting system:

Electric starter

## Lubrication system:

Wet sump

## Engine oil:

### Recommended brand:

YAMALUBE

### SAE viscosity grades:

10W-40

### Recommended engine oil grade:

API service SG type or higher, JASO standard MA

### Engine oil quantity:

#### Oil change:

4.30 L (4.55 US qt, 3.78 Imp.qt)

#### With oil filter removal:

4.70 L (4.97 US qt, 4.14 Imp.qt)

## Final gear oil:

### Type:

Yamaha genuine shaft drive gear oil SAE 80W-90 API GL-5

### Quantity:

0.30 L (0.32 US qt, 0.26 Imp.qt)

## Coolant quantity:

Coolant reservoir (up to the maximum level mark):

0.27 L (0.29 US qt, 0.24 Imp.qt)

### Radiator (including all routes):

3.75 L (3.96 US qt, 3.30 Imp.qt)

## Air filter:

### Air filter element:

Oil-coated paper element

## Fuel:

### Recommended fuel:

Premium unleaded gasoline (Gasohol [E10] acceptable)

### Fuel tank capacity:

15 L (4.0 US gal, 3.3 Imp.gal)

### Fuel reserve amount:

3.9 L (1.03 US gal, 0.86 Imp.gal)

## Fuel injection:

### Throttle body:

#### ID mark:

2S31 00

## Spark plug(s):

### Manufacturer/model:

NGK/CR9EIA

### Manufacturer/model:

DENSO/IU27D

### Spark plug gap:

0.8–0.9 mm (0.031–0.035 in)

## Clutch:

### Clutch type:

Wet, multiple-disc

## Drivetrain:

### Primary reduction ratio:

1.509 (86/57)

### Final drive:

Shaft

### Secondary reduction ratio:

3.082 (22/23 x 29/9)

### Transmission type:

Constant mesh 5-speed

### Gear ratio:

#### 1st:

2.375 (38/16)

# Specifications

- 2nd:  
1.810 (38/21)
- 3rd:  
1.400 (35/25)
- 4th:  
1.115 (29/26)
- 5th:  
0.935 (29/31)

## Chassis:

- Frame type:  
Diamond
- Caster angle:  
31.0 °
- Trail:  
148 mm (5.8 in)

## Front tire:

- Type:  
Tubeless
- Size:  
120/70R18M/C 59V
- Manufacturer/model:  
BRIDGESTONE/BT028F G

## Rear tire:

- Type:  
Tubeless
- Size:  
200/50R18M/C 76V
- Manufacturer/model:  
BRIDGESTONE/BT028R G

## Loading:

- Maximum load:  
190 kg (419 lb)  
(Total weight of rider, passenger, cargo  
and accessories)

## Tire air pressure (measured on cold tires):

- Up to 90 kg (198 lb) load:
  - Front:  
250 kPa (2.50 kgf/cm<sup>2</sup>, 36 psi)
  - Rear:  
290 kPa (2.90 kgf/cm<sup>2</sup>, 42 psi)
- 90 kg (198 lb) load - maximum load:
  - Front:  
250 kPa (2.50 kgf/cm<sup>2</sup>, 36 psi)
  - Rear:  
290 kPa (2.90 kgf/cm<sup>2</sup>, 42 psi)

## Front wheel:

- Wheel type:  
Cast wheel
- Rim size:  
18M/C x MT3.50

## Rear wheel:

- Wheel type:  
Cast wheel
- Rim size:  
18M/C x MT6.00

## Front brake:

- Type:  
Hydraulic dual disc brake
- Specified brake fluid:  
DOT 4

## Rear brake:

- Type:  
Hydraulic single disc brake
- Specified brake fluid:  
DOT 4

## Front suspension:

- Type:  
Telescopic fork
- Spring:  
Coil spring
- Shock absorber:  
Hydraulic damper
- Wheel travel:  
120 mm (4.7 in)

## Rear suspension:

- Type:  
Swingarm (link suspension)
- Spring:  
Coil spring
- Shock absorber:  
Gas-hydraulic damper
- Wheel travel:  
110 mm (4.3 in)

## Electrical system:

- System voltage:  
12 V
- Ignition system:  
TCI
- Charging system:  
AC magneto

## Battery:

- Model:  
YTZ14S
- Voltage, capacity:  
12 V, 11.2 Ah (10 HR)

## Headlight:

- Bulb type:  
Halogen bulb



**Bulb wattage × quantity:**

Headlight:  
H4, 60.0 W/55.0 W × 1

Brake/tail light:  
LED

Front turn signal light:  
10.0 W × 2

Rear turn signal light:  
10.0 W × 2

Auxiliary light:  
5.0 W × 1

License plate light:  
5.0 W × 1

Meter lighting:  
LED

Neutral indicator light:  
LED

High beam indicator light:  
LED

Oil level warning light:  
LED

Turn signal indicator light:  
LED

Fuel level warning light:  
LED

Coolant temperature warning light:  
LED

Engine trouble warning light:  
LED

ABS warning light:  
LED

Immobilizer system indicator light:  
LED

Shift timing indicator light:

LED

**Fuse(s):**

Main fuse:  
50.0 A

Headlight fuse:  
15.0 A

Signaling system fuse:  
7.5 A

Ignition fuse:  
20.0 A

Parking lighting fuse:  
7.5 A

Radiator fan motor fuse:  
20.0 A

Sub radiator fan motor fuse:  
7.5 A

Fuel injection system fuse:  
15.0 A

ABS control unit fuse:  
7.5 A

ABS motor fuse:  
30.0 A

ABS solenoid fuse:  
15.0 A

Backup fuse:  
7.5 A

Electronic throttle valve fuse:  
7.5 A

# Consumer information

EAU53562

## Identification numbers

Record the vehicle identification number, engine serial number, and the model label information in the spaces provided below. These identification numbers are needed when registering the vehicle with the authorities in your area and when ordering spare parts from a Yamaha dealer.

VEHICLE IDENTIFICATION NUMBER:

ENGINE SERIAL NUMBER:

MODEL LABEL INFORMATION:

## Vehicle identification number

EAU26401

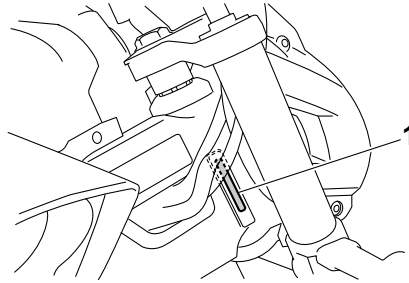

1. Vehicle identification number

The vehicle identification number is stamped into the steering head pipe. Record this number in the space provided.

### TIP

The vehicle identification number is used to identify your motorcycle and may be used to register your motorcycle with the licensing authority in your area.

## Engine serial number

EAU26442

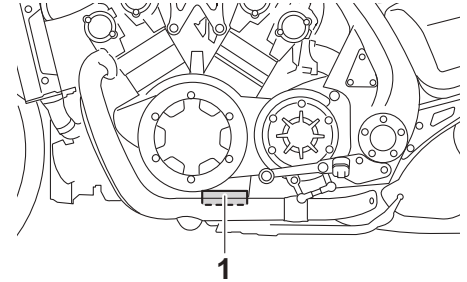

1. Engine serial number

The engine serial number is stamped into the crankcase.

## Model label

EAU26471

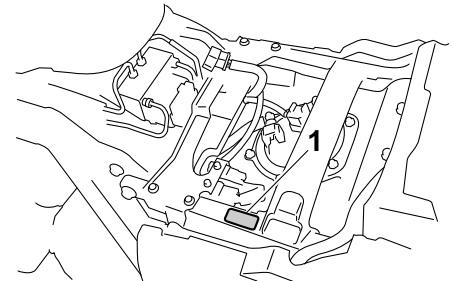

1. Model label

The model label is affixed to the frame under the rider seat. (See page 3-25.) Record the information on this label in the space provided. This information will be needed when ordering spare parts from a Yamaha dealer.

# Index

## A

- ABS .....3-20
- ABS warning light .....3-6
- Air filter element .....6-19
- Auxiliary light bulb, replacing.....6-37

## B

- Battery .....6-31
- Brake and clutch fluids, changing .....6-27
- Brake and clutch levers, checking and lubricating.....6-28
- Brake and shift pedals, checking and lubricating.....6-28
- Brake fluid level, checking.....6-25
- Brake lever.....3-19
- Brake lever free play, checking.....6-24
- Brake light switches.....6-24
- Brake pedal.....3-20
- Brake/tail light.....6-37

## C

- Cables, checking and lubricating .....6-27
- Care .....7-1
- Catalytic converters .....3-24
- Clutch lever.....3-18, 6-23
- Coolant .....6-16
- Coolant temperature warning light .....3-5
- Cowling and panels, removing and installing.....6-8

## D

- Dimmer switch .....3-17

## E

- Engine break-in.....5-3
- Engine idling speed, checking .....6-20
- Engine oil and oil filter cartridge .....6-11
- Engine serial number .....9-1

- Engine stop switch .....3-18
- Engine trouble warning light.....3-5
- EXUP system.....3-31

## F

- Final gear oil .....6-14
- Front and rear brake pads, checking...6-25
- Front fork, adjusting .....3-26
- Front fork, checking .....6-30
- Fuel.....3-22
- Fuel consumption, tips for reducing .....5-3
- Fuel level warning light .....3-5
- Fuel tank breather hose and overflow hose .....3-24
- Fuel tank cap.....3-21
- Fuses, replacing .....6-34

## H

- Handlebar switches.....3-17
- Hazard switch.....3-18
- Headlight bulb, replacing .....6-35
- High beam indicator light .....3-4
- Horn switch .....3-18

## I

- Identification numbers.....9-1
- Ignition circuit cut-off system.....3-32
- Immobilizer system .....3-1
- Immobilizer system indicator light.....3-6
- Indicator lights and warning lights .....3-4

## L

- License plate light bulb, replacing.....6-38
- Luggage strap holders .....3-30

## M

- Main switch/steering lock.....3-2
- Maintenance and lubrication, periodic...6-4

## Maintenance, emission control

- system .....6-3
- Matte color, caution .....7-1
- Model label .....9-1
- Multi-function display .....3-8

## N

- Neutral indicator light.....3-4

## O

- Oil level warning light .....3-4

## P

- Parking.....5-4
- Part locations .....2-1
- Pass switch.....3-17

## S

- Safety information.....1-1
- Seats .....3-25
- Shifting.....5-2
- Shift pedal.....3-19
- Shift timing indicator light .....3-6
- Shock absorber assembly, adjusting...3-28
- Sidestand .....3-31
- Sidestand, checking and lubricating....6-29
- Spark plugs, checking .....6-10
- Specifications .....8-1
- Speedometer unit .....3-7
- Starting the engine.....5-1
- Start switch .....3-18
- Steering, checking .....6-30
- Storage .....7-4
- Supporting the motorcycle .....6-39
- Swingarm pivots, lubricating .....6-29

## T

- Throttle grip and cable, checking and lubricating.....6-27

Throttle grip free play, checking.....	6-20
Tires.....	6-21
Tool kit.....	6-2
Troubleshooting.....	6-40
Troubleshooting charts.....	6-41
Turn signal indicator lights .....	3-4
Turn signal light bulb, replacing .....	6-38
Turn signal switch.....	3-18

## **V**

Valve clearance .....	6-20
Vehicle identification number .....	9-1

## **W**

Wheel bearings, checking .....	6-31
Wheels.....	6-23





