



# OWNER'S MANUAL 2021

EC 250

EC 300

Art. no. 3215011en



# **GASGAS**



Congratulations on your decision to purchase a GASGAS motorcycle. You are now the owner of a state-of-the-art sports vehicle which, with appropriate care, will bring you pleasure for a long time to come.

We wish you good and safe riding at all times!

Enter the serial numbers of your vehicle below.

Vehicle identification number (📖 p. 12)	Dealer's stamp
Engine number (📖 p. 12)	
Key number (All EU models) (📖 p. 12)	

The Owner's Manual contained the latest information for this model series at the time of going to print. However, minor differences due to further developments in design cannot be ruled out completely.

All specifications contained herein are non-binding. GASGAS Motorcycles GmbH specifically reserves the right to modify or delete technical specifications, prices, colors, forms, materials, services, designs, equipment, etc., without prior notice and without specifying reasons, to adapt these to local conditions, as well as to stop production of a particular model without prior notice. GASGAS Motorcycles accepts no liability for delivery options, deviations from illustrations and descriptions, as well as misprints and other errors. The models portrayed partly contain special equipment that does not belong to the regular scope of supply.

© 2020 GASGAS Motorcycles GmbH, Mattighofen Austria

All rights reserved

Reproduction, even in part, as well as copying of all kinds, is permitted only with the express written permission of the copyright owner.



ISO 9001(12 100 6061)

GASGAS Motorcycles applies quality assurance processes that lead to the highest possible product quality as defined in the ISO 9001 international quality management standard.

Issued by: TÜV Management Service

GASGAS Motorcycles GmbH  
Stallhofnerstraße 3  
5230 Mattighofen, Austria

This document is valid for the following models:

EC 250 EU (F0303U7)

































EC 300 EU (F0403U7)

EC 300 US (F0475U7)















# TABLE OF CONTENTS

1	MEANS OF REPRESENTATION .....	5	6.18	Cold start button .....	19
1.1	Symbols used.....	5	6.19	Idle speed adjusting screw .....	19
1.2	Formats used.....	5	6.20	Shift lever.....	20
2	SAFETY ADVICE .....	6	6.21	Foot brake lever .....	20
2.1	Use definition – intended use .....	6	6.22	Side stand .....	20
2.2	Misuse.....	6	6.23	Steering lock (All EU models) .....	21
2.3	Safety advice.....	6	6.24	Locking the steering (All EU models) .....	21
2.4	Degrees of risk and symbols .....	6	6.25	Unlocking the steering (All EU models) .....	21
2.5	Tampering warning .....	7	7	COMBINATION INSTRUMENT.....	22
2.6	Safe operation .....	7	7.1	Combination instrument overview .....	22
2.7	Protective clothing .....	7	7.2	Activation.....	22
2.8	Work rules .....	8	7.3	Messages on the combination instrument .....	22
2.9	Environment.....	8	7.4	Setting the combination instrument .....	22
2.10	Owner's Manual .....	8	7.5	Setting the kilometers or miles.....	23
3	IMPORTANT NOTES .....	9	7.6	Setting the clock.....	24
3.1	Manufacturer warranty, implied warranty .....	9	7.7	Setting the service display.....	24
3.2	Fuel, auxiliary substances.....	9	7.8	Speed, time, and DST distance 1.....	25
3.3	Spare parts, accessories .....	9	7.9	Speed, time, and DST2 distance 2 .....	25
3.4	Service .....	9	7.10	AVG average speed, ART operating hours, and ODO total distance covered .....	26
3.5	Figures .....	9	8	PREPARING FOR USE .....	27
3.6	Customer service.....	9	8.1	Advice on preparing for first use .....	27
4	VIEW OF VEHICLE .....	10	8.2	Running in the engine .....	28
4.1	View of vehicle, front left (example) .....	10	8.3	Starting power of lithium-ion batteries at low temperatures.....	29
4.2	View of vehicle, rear right (example).....	11	8.4	Preparing the vehicle for difficult riding conditions .....	29
5	SERIAL NUMBERS.....	12	8.5	Preparing the vehicle for rides on dry sand .....	29
5.1	Vehicle identification number.....	12	8.6	Preparing the vehicle for rides on wet sand .....	31
5.2	Type label .....	12	8.7	Preparing the vehicle for rides on wet and muddy circuits.....	32
5.3	Key number (All EU models) .....	12	8.8	Preparing vehicle for high temperatures or slow riding.....	32
5.4	Engine number .....	12	8.9	Preparing the vehicle for low temperatures or snow .....	33
5.5	Fork part number .....	13	9	RIDING INSTRUCTIONS .....	34
5.6	Shock absorber article number.....	13	9.1	Checks and maintenance measures when preparing for use.....	34
6	CONTROLS.....	14	9.2	Starting the vehicle .....	34
6.1	Clutch lever.....	14	9.3	Starting off .....	35
6.2	Hand brake lever .....	14	9.4	Shifting, riding .....	35
6.3	Throttle grip.....	14	9.5	Braking.....	36
6.4	Stop button (All EU models).....	14	9.6	Stopping, parking.....	36
6.5	Stop button (EC 300 US) .....	15	9.7	Transporting .....	37
6.6	Horn button (All EU models) .....	15	9.8	Refueling.....	37
6.7	Light switch (All EU models).....	15	9.9	Adding 2-stroke oil .....	38
6.8	Light switch (EC 300 US).....	15	10	SERVICE SCHEDULE.....	40
6.9	Turn signal switch (All EU models).....	16	10.1	Additional information .....	40
6.10	Emergency OFF switch (All EU models) .....	16	10.2	Required work .....	40
6.11	Start button .....	16	10.3	Recommended work .....	41
6.12	Overview of indicator lamps (All EU models).....	16			
6.13	Overview of indicator lamps (EC 300 US) .....	17			
6.14	Opening the fuel tank filler cap.....	17			
6.15	Closing the fuel tank filler cap.....	18			
6.16	Opening 2-stroke oil tank cap .....	18			
6.17	Closing 2-stroke oil tank cap .....	18			

11	TUNING THE CHASSIS .....	43	12.26	Removing the main silencer.....	68
11.1	Checking the basic chassis setting with the rider's weight .....	43	12.27	Installing the main silencer .....	69
11.2	Compression damping of the shock absorber .....	43	12.28	Changing the glass fiber yarn filling of the main silencer  .....	69
11.3	Adjusting the low-speed compression damping of the shock absorber .....	43	12.29	Removing the fuel tank  .....	70
11.4	Adjusting the high-speed compression damping of the shock absorber .....	44	12.30	Installing the fuel tank  .....	71
11.5	Adjusting the rebound damping of the shock absorber .....	45	12.31	Checking the chain for dirt.....	73
11.6	Measuring the dimension of the rear wheel unloaded.....	45	12.32	Cleaning the chain .....	73
11.7	Checking the static sag of the shock absorber .....	46	12.33	Checking the chain tension.....	74
11.8	Checking the riding sag of the shock absorber .....	46	12.34	Adjusting the chain tension .....	74
11.9	Adjusting the spring preload of the shock absorber  .....	47	12.35	Checking the chain, rear sprocket, engine sprocket, and chain guide .....	75
11.10	Adjusting the riding sag  .....	48	12.36	Checking the frame  .....	78
11.11	Checking the basic setting of the fork .....	48	12.37	Checking the link fork  .....	78
11.12	Adjusting the compression damping of the fork .....	49	12.38	Checking the throttle cable routing.....	78
11.13	Adjusting the rebound damping of the fork.....	49	12.39	Checking the rubber grip .....	79
11.14	Handlebar position.....	50	12.40	Adjusting the basic position of the clutch lever .....	79
11.15	Adjusting the handlebar position  .....	50	12.41	Checking/correcting the fluid level of the hydraulic clutch .....	79
12	SERVICE WORK ON THE CHASSIS .....	52	12.42	Changing the hydraulic clutch fluid  .....	80
12.1	Raising the motorcycle with a lift stand .....	52	13	BRAKE SYSTEM.....	82
12.2	Removing the motorcycle from the lift stand .....	52	13.1	Checking the free travel of the hand brake lever.....	82
12.3	Bleeding the fork legs.....	52	13.2	Adjusting the basic position of the hand brake lever (EC 300 US).....	82
12.4	Cleaning the dust boots of the fork legs.....	53	13.3	Checking the brake discs.....	82
12.5	Removing the fork protector .....	53	13.4	Checking the front brake fluid level.....	83
12.6	Installing the fork protector .....	54	13.5	Adding front brake fluid  .....	83
12.7	Removing the fork legs  .....	54	13.6	Checking the front brake linings .....	85
12.8	Installing the fork legs  .....	55	13.7	Changing the brake linings of the front brake  .....	85
12.9	Removing the lower triple clamp  .....	55	13.8	Checking the free travel of foot brake lever .....	87
12.10	Installing the lower triple clamp  .....	56	13.9	Adjusting the basic position of the foot brake lever  .....	88
12.11	Checking steering head bearing play .....	58	13.10	Checking the rear brake fluid level .....	88
12.12	Adjusting the steering head bearing play  .....	59	13.11	Adding rear brake fluid  .....	89
12.13	Lubricating the steering head bearing  .....	60	13.12	Checking the brake linings of the rear brake.....	90
12.14	Removing front fender.....	60	13.13	Changing the rear brake linings  .....	90
12.15	Installing front fender .....	60	14	WHEELS, TIRES.....	93
12.16	Removing the shock absorber  .....	61	14.1	Removing the front wheel  .....	93
12.17	Installing the shock absorber  .....	63	14.2	Installing the front wheel  .....	94
12.18	Removing the seat.....	64	14.3	Removing the rear wheel  .....	94
12.19	Mounting the seat.....	65	14.4	Installing the rear wheel  .....	95
12.20	Removing the air filter box cover.....	65	14.5	Checking the tire condition.....	97
12.21	Installing the air filter box cover .....	66	14.6	Checking tire pressure.....	97
12.22	Removing the air filter  .....	66	14.7	Checking spoke tension.....	98
12.23	Installing the air filter  .....	67	15	ELECTRICAL SYSTEM .....	99
12.24	Cleaning the air filter and air filter box  .....	67	15.1	Removing the 12-V battery  .....	99
12.25	Preparing air filter box cover for securing  .....	68	15.2	Installing the 12-V battery  .....	100
			15.3	Charging the 12-V battery  .....	102
			15.4	Changing main fuse.....	103

# TABLE OF CONTENTS

15.5	Changing the fuses of individual electrical power consumers.....	105	22	BLINK CODE.....	139
15.6	Removing the headlight mask with the headlight.....	106	23	TECHNICAL DATA.....	141
15.7	Installing the headlight mask with the headlight.....	106	23.1	Engine.....	141
15.8	Changing the headlight bulb.....	107	23.1.1	EC 250 EU.....	141
15.9	Changing the turn signal bulb (All EU models).....	108	23.1.2	All 300 models.....	141
15.10	Checking the headlight setting.....	108	23.2	Motor tightening torques.....	142
15.11	Adjusting the headlight range.....	109	23.3	Capacities.....	144
15.12	Changing the combination instrument battery.....	109	23.3.1	Gear oil.....	144
15.13	Diagnostics connector.....	110	23.3.2	Coolant.....	144
16	COOLING SYSTEM.....	111	23.3.3	Fuel.....	144
16.1	Cooling system.....	111	23.4	Chassis.....	144
16.2	Checking the antifreeze and coolant level.....	111	23.5	Electrical system.....	145
16.3	Checking the coolant level.....	112	23.6	Tires.....	145
16.4	Draining the coolant  .....	112	23.7	Fork.....	145
16.5	Refilling with coolant  .....	113	23.8	Shock absorber.....	146
16.6	Changing the coolant  .....	115	23.9	Chassis tightening torques.....	146
17	TUNING THE ENGINE.....	117	24	SUBSTANCES.....	149
17.1	Checking the play in the throttle cable....	117	25	AUXILIARY SUBSTANCES.....	151
17.2	Adjusting the play in the throttle cable  .....	117	26	STANDARDS.....	153
17.3	Setting the characteristic map of the throttle response  .....	118	27	INDEX OF SPECIAL TERMS.....	154
17.4	Adjusting the idle speed  .....	119	28	LIST OF ABBREVIATIONS.....	155
17.5	Programming ambient air pressure.....	120	29	LIST OF SYMBOLS.....	156
17.6	Ignition curve plug-in connector.....	120	29.1	Red symbols.....	156
17.7	Changing the ignition timing map.....	121	29.2	Yellow and orange symbols.....	156
17.8	Checking the basic position of the shift lever.....	121	29.3	Green and blue symbols.....	156
17.9	Adjusting the basic position of the shift lever  .....	122	INDEX.....		157
18	SERVICE WORK ON THE ENGINE.....	123			
18.1	Changing the fuel screen  .....	123			
18.2	Checking 2-stroke oil level.....	124			
18.3	Priming oil pump  .....	124			
18.4	Cleaning the oil screen in the oil tank  .....	126			
18.5	Checking the gear oil level.....	128			
18.6	Changing the gear oil  .....	129			
18.7	Adding the gear oil  .....	130			
19	CLEANING, CARE.....	132			
19.1	Cleaning the motorcycle.....	132			
19.2	Checks and maintenance steps for winter operation.....	133			
20	STORAGE.....	134			
20.1	Storage.....	134			
20.2	Preparing for use after storage.....	135			
21	TROUBLESHOOTING.....	136			

## 1.1 Symbols used

The meaning of specific symbols is described below.



Indicates an expected reaction (e.g., of a work step or a function).



Indicates an unexpected reaction (e.g., of a work step or a function).



All work marked with this symbol requires specialist knowledge and technical understanding. In the interest of your own safety, have this work performed by an authorized GASGAS Motorcycles workshop. Your motorcycle will be cared for there to the highest degree by specially trained experts using the special tools required.



Indicates a page reference (more information is provided on the specified page).



Indicates information with more details or tips.



Indicates the result of a testing step.



Indicates a voltage measurement.



Indicates a current measurement.



Indicates the end of an activity, including potential reworking.

## 1.2 Formats used

The typographical formats used in this document are explained below.

<b>Proprietary name</b>	Indicates a proprietary name.
<b>Name®</b>	Indicates a protected name.
<b>Brand™</b>	Indicates a brand available on the open market.
<b><u>Underlined terms</u></b>	Refer to technical details of the vehicle or indicate technical terms, which are explained in the glossary.

### 2.1 Use definition – intended use

This vehicle has been designed and built to withstand the normal stresses and strains of racing. This vehicle complies with the currently valid regulations and categories of the top international motorsports organizations.



#### Info

This vehicle is only authorized for operation on public roads in the homologated (restricted) version. The derestricted version of this vehicle must only be operated in closed off areas away from public highway traffic. This vehicle is designed for use in offroad endurance competition, and not primarily for use in motocross.

### 2.2 Misuse

The vehicle must only be used as intended.

Dangers can arise for people, property and the environment through use not as intended.

Any use of the vehicle beyond the intended and defined use constitutes misuse.

Misuse also includes the use of operating and auxiliary fluids which do not meet the required specification for the respective use.

### 2.3 Safety advice

A number of safety instructions need to be followed to operate the product described safely. Therefore read this instruction and all further instructions included carefully. The safety instructions are highlighted in the text and are referred to at the relevant passages.



#### Info

Various information and warning labels are attached in prominent locations on the product described. Do not remove any information or warning labels. If they are missing, you or others may not recognize dangers and may therefore be injured.

### 2.4 Degrees of risk and symbols



#### Danger

Identifies a danger that will immediately and invariably lead to fatal or serious permanent injury if the appropriate measures are not taken.



#### Warning

Identifies a danger that is likely to lead to fatal or serious injury if the appropriate measures are not taken.



#### Caution

Identifies a danger that may lead to minor injuries if the appropriate measures are not taken.

#### Note

Identifies a danger that will lead to considerable machine and material damage if the appropriate measures are not taken.



#### Note

Indicates a danger that will lead to environmental damage if the appropriate measures are not taken.



## 2.5 Tampering warning

Tampering with the noise control system is prohibited. Federal law prohibits the following acts or the causing thereof:

- 1 The removal or rendering inoperative by any person other than for purposes of servicing, repair, or replacement, of any device or element of design incorporated into any new vehicle for the purpose of noise control prior to its sale or delivery to the ultimate purchaser or while it is in use, or
- 2 the use of the vehicle after such device or element of design has been removed or rendered inoperative by any person.

Among those acts presumed to constitute tampering are the acts listed below:

- 1 Removal or puncturing of the main silencers, baffles, header pipes or any other components which conduct exhaust gases.
- 2 Removal or puncturing of parts of the intake system.
- 3 Lack of proper maintenance.
- 4 Replacing moving parts of the vehicle, or parts of the exhaust system or intake system, with parts other than those specified by the manufacturer.

## 2.6 Safe operation



### Danger

**Danger of accidents** A rider who is not fit to ride poses a danger to him or herself and others.

- Do not operate the vehicle if you are not fit to ride due to alcohol, drugs or medication.
- Do not operate the vehicle if you are physically or mentally impaired.



### Danger

**Danger of poisoning** Exhaust gases are toxic and inhaling them may result in unconsciousness and death.

- Always make sure there is sufficient ventilation when running the engine.
- Use effective exhaust extraction when starting or running the engine in an enclosed space.



### Warning

**Danger of burns** Some vehicle components become very hot when the vehicle is operated.

- Do not touch any parts such as the exhaust system, radiator, engine, shock absorber, or brake system before the vehicle parts have cooled down.
- Let the vehicle parts cool down before you perform any work on the vehicle.

Only operate the vehicle when it is in perfect technical condition, in accordance with its intended use, and in a safe and environmentally compatible manner.

The vehicle should only be used by trained persons. An appropriate driver's license is needed to drive the vehicle on public roads.

Have malfunctions that impair safety immediately eliminated by an authorized GASGAS Motorcycles workshop.

Adhere to the information and warning labels on the vehicle.

## 2.7 Protective clothing



### Warning

**Risk of injury** Missing or poor protective clothing presents an increased safety risk.

- Wear appropriate protective clothing such as helmet, boots, gloves as well as trousers and a jacket with protectors on all rides.
- Always wear protective clothing that is in good condition and meets the legal regulations.

In the interest of your own safety, GASGAS Motorcycles recommends that you only operate the vehicle while wearing protective clothing.

### 2.8 Work rules

Unless specified otherwise, the ignition must be turned off during all work (models with ignition lock, models with remote key) or the engine must be at a standstill (models without ignition lock or remote key).

Special tools are necessary for certain tasks. The tools are not a component of the vehicle, but can be ordered using the number in parentheses. Example: bearing puller (15112017000)

During assembly, use new parts to replace parts which cannot be reused (e.g. self-locking screws and nuts, expansion screws, seals, sealing rings, O-rings, pins, and lock washers).

In the case of certain screws, a screw adhesive (e.g., **Loctite**<sup>®</sup>) is required. Observe the manufacturer's instructions.

If thread locker (e.g., **Precote**<sup>®</sup>) has already been applied to a new part, do not apply any additional thread locker.

After disassembly, clean the parts that are to be reused and check them for damage and wear. Change damaged or worn parts.

After completing a repair or service work, check the operating safety of the vehicle.

### 2.9 Environment

If you use your motorcycle responsibly, you can ensure that problems and conflicts do not occur. To protect the future of the motorcycle sport, make sure that you use your motorcycle legally, be environmentally aware, and respect the rights of others.

When disposing of used oil, other operating and auxiliary fluids, and used components, comply with the laws and regulations of the respective country.

Because motorcycles are not subject to the EU regulations governing the disposal of used vehicles, there are no legal regulations that pertain to the disposal of an end-of-life motorcycle. Your authorized GASGAS Motorcycles dealer will be glad to advise you.

### 2.10 Owner's Manual

It is important that you read this Owner's Manual carefully and completely before making your first trip. The Owner's Manual contains useful information and many tips on how to operate, handle, and service your motorcycle. This is the only way to find out how best to customize the vehicle for your own use and how you can protect yourself from injury.



#### Tip

Store the Owner's Manual on your terminal device, for example, so that you can read it whenever you need to.

---

If you would like to know more about the vehicle or have questions on the material you read, please contact an authorized GASGAS Motorcycles dealer.

The Owner's Manual is an important component of the vehicle. If the vehicle is sold, the Owner's Manual must be downloaded again by the new owner.

The Owner's Manual is also available for download from your authorized GASGAS Motorcycles dealer and on the GASGAS Motorcycles website. A printed copy can also be ordered from your authorized GASGAS Motorcycles dealer. International GASGAS Motorcycles website: <http://www.gasgas.com>

**3.1 Manufacturer warranty, implied warranty**

The work specified in the service schedule may only be carried out in an authorized GASGAS Motorcycles workshop and confirmed in the **GASGAS Motorcycles Dealer.net**, as otherwise all warranty claims will be void. Damage or secondary damage caused by tampering with and/or conversions on the vehicle are not covered by the manufacturer warranty.

**3.2 Fuel, auxiliary substances**



**Note**

**Environmental hazard** Improper handling of fuel is a danger to the environment.

- Do not allow fuel to enter the groundwater, the soil, or the sewage system.

Use fuels and auxiliary substances in accordance with the Owner's Manual and specification.

**3.3 Spare parts, accessories**

For your own safety, only use spare parts and accessory products that are approved and/or recommended by GASGAS Motorcycles and have them installed by an authorized GASGAS Motorcycles workshop. GASGAS Motorcycles accepts no liability for other products and any resulting damage or loss. Certain spare parts and accessory products are specified in parentheses in the descriptions. Your authorized GASGAS Motorcycles dealer will be glad to advise you.

The latest news **GASGAS Technical Accessories** on your vehicle can be found on the GASGAS Motorcycles website. International GASGAS Motorcycles website: <http://www.gasgas.com>

**3.4 Service**

A prerequisite for perfect operation and prevention of premature wear is that the service, care, and tuning work on the engine and chassis is properly carried out as described in the Owner's Manual. An incorrect suspension setting can lead to damage and breakage of chassis components.

Use of the vehicle under difficult conditions, such as on sand or on wet and muddy surfaces, can result in significantly increased wear of components, such as the drive train, brake system, or suspension components. For this reason, it may be necessary to inspect or replace parts before the next scheduled service.

It is imperative that you adhere to the stipulated run-in times and service intervals. If you observe these exactly, you will ensure a much longer service life for your motorcycle.

The relevant mileage or time interval is whichever occurs first.

**3.5 Figures**

The figures contained in the manual may depict special equipment.

In the interest of clarity, some components may be shown disassembled or may not be shown at all. It is not always necessary to disassemble the component to perform the activity in question. Please follow the instructions in the text.

**3.6 Customer service**

Your authorized GASGAS Motorcycles dealer will be happy to answer any questions you may have regarding your vehicle and GASGAS Motorcycles.

A list of authorized GASGAS Motorcycles dealers can be found on the GASGAS Motorcycles website. International GASGAS Motorcycles website: <http://www.gasgas.com>

## 4 VIEW OF VEHICLE

### 4.1 View of vehicle, front left (example)



S04403-10

- ① Hand brake lever (📖 p. 14)
- ② Clutch lever (📖 p. 14)
- ③ Light switch (📖 p. 15) **(All EU models)**
- ③ Stop button (📖 p. 14) **(All EU models)**
- ③ Turn signal switch (📖 p. 16) **(All EU models)**
- ③ Horn button (📖 p. 15) **(All EU models)**
- ④ Ignition curve plug-in connector (📖 p. 120)
- ⑤ Side stand (📖 p. 20)
- ⑥ Air filter box cover
- ⑦ Shift lever (📖 p. 20)

**4.2 View of vehicle, rear right (example)**

- ❶ Fuel tank filler cap
- ❷ Throttle grip (📖 p. 14)
- ❸ Vehicle identification number (📖 p. 12)
- ❹ Foot brake lever (📖 p. 20)
- ❺ Level viewer for brake fluid, rear

## 5 SERIAL NUMBERS

### 5.1 Vehicle identification number

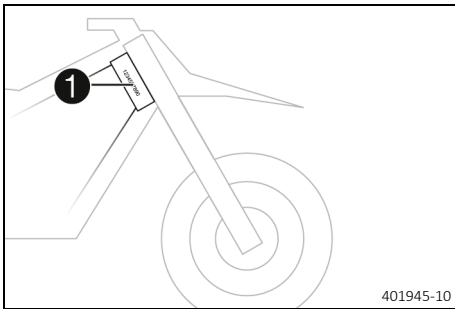

The vehicle identification number **1** is stamped on the right side of the steering head.

### 5.2 Type label

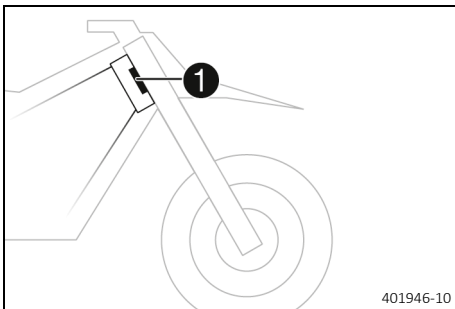

Type label **1** is fixed to the front of the steering head.

### 5.3 Key number (All EU models)

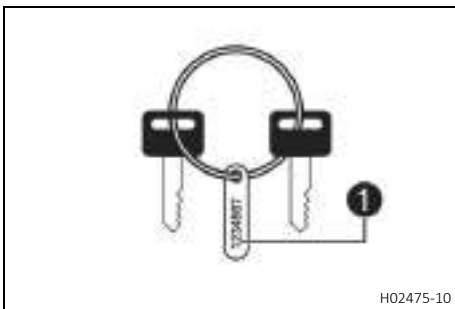

The key number **1** for the steering lock is stamped onto the key connector.

### 5.4 Engine number

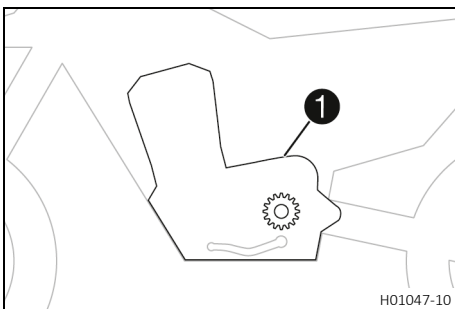

The engine number **1** is located on the left side of the engine over the engine sprocket.

**5.5 Fork part number**

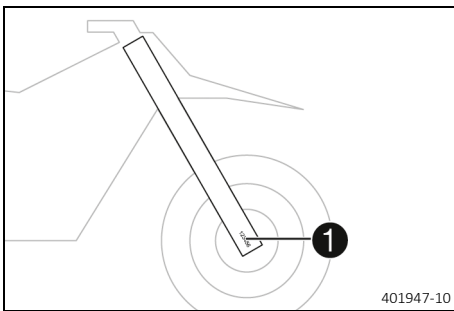

The fork part number **1** is stamped on the inside of the axle clamp.

**5.6 Shock absorber article number**

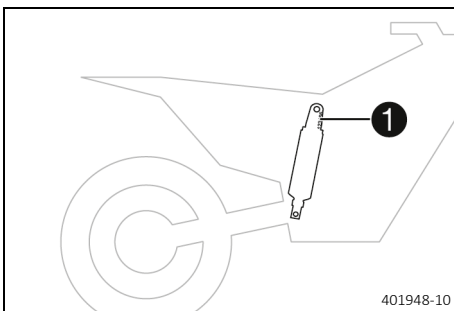

Shock absorber article number **1** is stamped on the top of the shock absorber above the adjusting ring towards the engine side.

## 6.1 Clutch lever

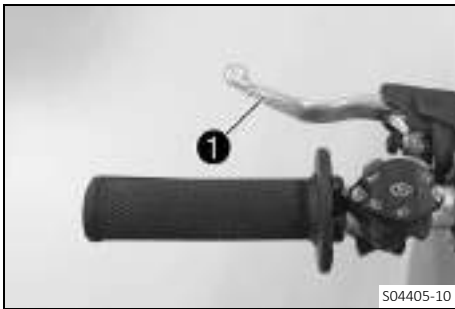

Clutch lever ❶ is fitted on the handlebar on the left.  
The clutch is activated hydraulically and adjusts itself automatically.

## 6.2 Hand brake lever



Hand brake lever ❶ is fitted on the right side of the handlebar.  
The front brake is engaged using the hand brake lever.

## 6.3 Throttle grip



Throttle grip ❶ is fitted on the right side of the handlebar.

## 6.4 Stop button (All EU models)



The stop button ❶ is fitted on the left side of the handlebar.

### Possible states

- The stop button ☒ is in the basic position – In this position, the ignition circuit is closed and the engine can be started.
- Stop button ☒ pressed – In this position, the ignition circuit is interrupted, a running engine stops, and a non-running engine will not start.



**6.5 Stop button (EC 300 US)**

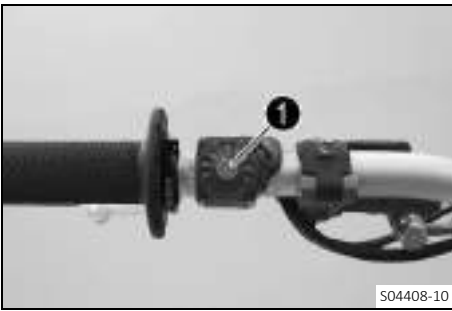

The stop button ① is fitted on the left side of the handlebar.

**Possible states**

- The stop button ☒ is in the basic position – In this position, the ignition circuit is closed and the engine can be started.
- Stop button ☒ pressed – In this position, the ignition circuit is interrupted, a running engine stops, and a non-running engine will not start.

**6.6 Horn button (All EU models)**



Horn button ① is fitted on the left side of the handlebar.

**Possible states**



- The horn button is in the basic position
- The horn button is pressed – The horn is operated in this position.

**6.7 Light switch (All EU models)**



Light switch ① is fitted on the left side of the handlebar.

**Possible states**

	Low beam on – Light switch is in the central position. In this position, the low beam and tail light are switched on.
	High beam on – Light switch is turned to the left. In this position, the high beam and the tail light are switched on.

**6.8 Light switch (EC 300 US)**



The light switch ① is located to the left of the combination instrument.

**Possible states**

- Light off – Light switch is pressed in up to the stop. In this position, the light is switched off.
- Light on – Light switch is pulled out to the stop. In this position, the low beam and tail light are switched on.

## 6.9 Turn signal switch (All EU models)



Turn signal switch ① is fitted on the left side of the handlebar.

### Possible states

	Turn signal off – The turn signal switch is in the central position.
←	Left turn signal, on – The turn signal switch is turned to the left.
→	Right turn signal, on – The turn signal switch is turned to the right.

## 6.10 Emergency OFF switch (All EU models)



The emergency OFF switch ① is fitted on the right side of the handlebar.

### Possible states

	Ignition off – In this position, the ignition circuit is interrupted, a running engine stops, and a non-running engine will not start.
	Ignition on – In this position, the ignition circuit is closed, and the engine can be started.

## 6.11 Start button



Start button ① is fitted on the right side of the handlebar.

### Possible states

- The start button ② is in the basic position
- The start button ② is pressed – In this position, the starter motor is actuated.

## 6.12 Overview of indicator lamps (All EU models)



### Possible states

	The high beam indicator lamp lights up blue – The high beam is switched on.
	Malfunction indicator lamp lights up/flashes yellow – The OBD has detected an error in the vehicle electronics. Come safely to a halt, and contact an authorized GASGAS Motorcycles workshop.
	The fuel level warning lamp lights up yellow – The fuel level has reached the reserve mark.
	Turn signal indicator lamp flashes green – The turn signal is switched on.





	The oil level warning lamp lights up red – Oil level has reached the <b>MIN</b> marking. Ride for no more than until the remaining fuel in the tank is depleted and at the next opportunity refuel with 2-stroke oil.
---	---

**6.13 Overview of indicator lamps (EC 300 US)**



S04413-01

**Possible states**

	High beam indicator lamp – inoperative
	Malfunction indicator lamp lights up/flashes yellow – The <u>OBD</u> has detected an error in the vehicle electronics. Come safely to a halt, and contact an authorized GASGAS Motorcycles workshop.
	The fuel level warning lamp lights up yellow – The fuel level has reached the reserve mark.
	The oil level warning lamp lights up red – Oil level has reached the <b>MIN</b> marking. Ride for no more than until the remaining fuel in the tank is depleted and at the next opportunity refuel with 2-stroke oil.

**6.14 Opening the fuel tank filler cap**



**Danger**

**Fire hazard** Fuel is highly flammable.

The fuel in the fuel tank expands when warm and can escape if overfilled.

- Do not fuel the vehicle in the vicinity of open flames or lit cigarettes.
- Switch off the engine for refueling.
- Make sure that no fuel is spilled; particularly not on hot parts of the vehicle.
- If any fuel is spilled, wipe it off immediately.
- Observe the specifications for refueling.



**Warning**

**Danger of poisoning** Fuel is poisonous and a health hazard.

- Avoid skin, eye and clothing contact with fuel.
- Immediately consult a doctor if you swallow fuel.
- Do not inhale fuel vapors.
- In case of skin contact, rinse the affected area with plenty of water.
- Rinse the eyes thoroughly with water, and consult a doctor in case of fuel contact with the eyes.
- Change your clothing in case of fuel spills on them.
- Keep fuels correctly in a suitable canister, and out of the reach of children.



**Note**

**Environmental hazard** Improper handling of fuel is a danger to the environment.

- Do not allow fuel to enter the groundwater, the soil, or the sewage system.

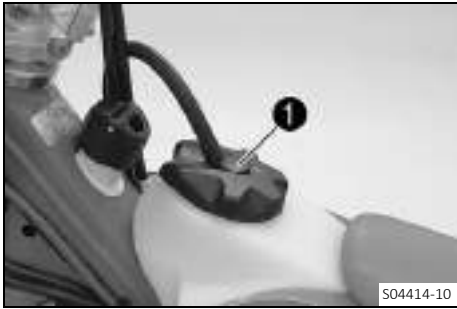

- Press release button **1**, turn the fuel tank filler cap counterclockwise, and lift it off.

## 6.15 Closing the fuel tank filler cap

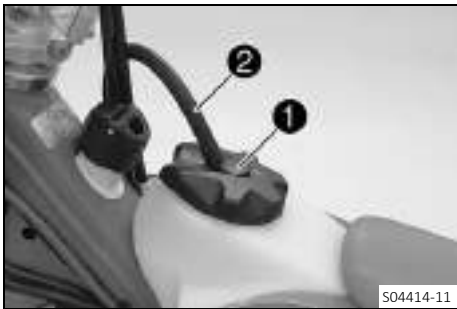

- Mount the fuel tank filler cap and turn it clockwise until release button **1** engages.



### Info

Route fuel tank breather hose **2** without kinks.

## 6.16 Opening 2-stroke oil tank cap



- Fold loop **1** upward.
- Turn the 2-stroke oil tank cap counterclockwise and pull it up.

## 6.17 Closing 2-stroke oil tank cap



- Put the 2-stroke oil tank cap on and turn it clockwise.
- Fold loop **1** down.
- ✓ The 2-stroke oil tank cap engages.

### 6.18 Cold start button



S03529-10

The cold start button ① is fitted on the side of the throttle valve body. If the engine is cold and the ambient temperature is low, the electronic fuel injection system extends the injection time. To help the engine burn the increased fuel quantity, it must be supplied with additional oxygen by pulling the cold start button.



#### Info

If the engine is warm, the cold start button must be deactivated.

#### Possible states

- The cold start button is activated – The cold start button is pulled out all the way and turned by a ¼ turn.
- The cold start button is deactivated – A further ¼ turn returns the cold start button back to the basic position.

### 6.19 Idle speed adjusting screw



S03529-11

The idle setting of the throttle valve body substantially influences the vehicle's starting behavior, a stable idle speed, and the vehicle's response when the throttle is opened. An engine with a correctly set idle speed is easier to start than an engine with the idle speed set incorrectly.

The idle speed is adjusted using the idle speed adjusting screw ①.



#### Info

If the idle speed is high, the engine is slow to run, the engine brake is low and the throttle response is aggressive, the adjusting screw must be turned clockwise.  
If the idle speed is low, the engine is running fast, the engine brake is high and the throttle response is not clean, the adjusting screw must be turned counterclockwise.

## 6.20 Shift lever

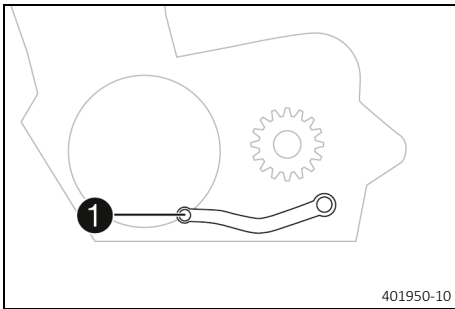

Shift lever **1** is mounted on the left side of the engine.

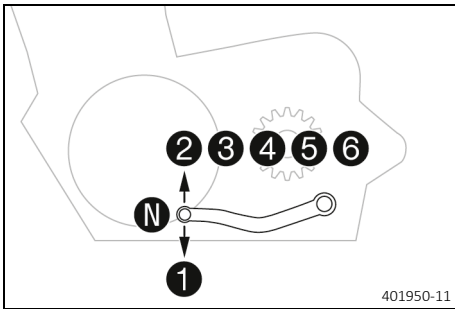

The gear positions can be seen in the photograph. The neutral or idle position is between the first and second gears.

## 6.21 Foot brake lever

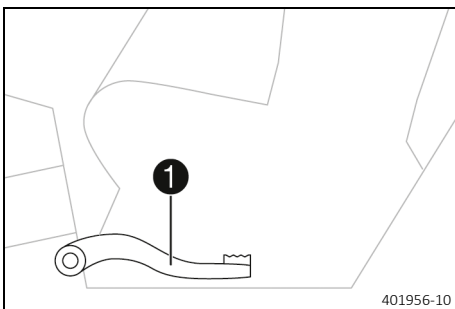

Foot brake lever **1** is located in front of the right footrest. The foot brake lever is used to activate the rear brake.

## 6.22 Side stand

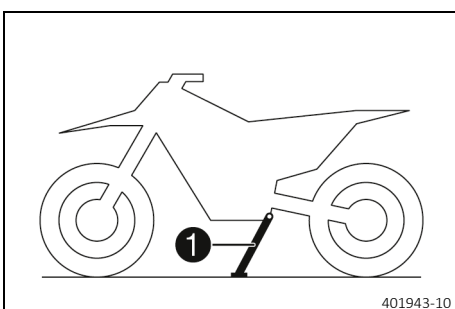

The side stand **1** is located on the left of the vehicle.

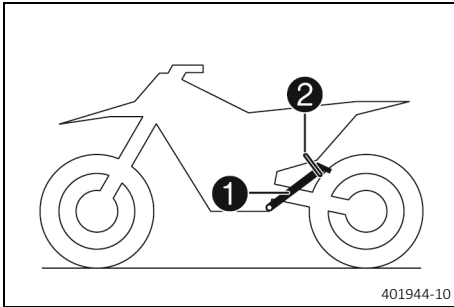

The side stand is used for parking the motorcycle.



**Info**

When you are riding, side stand **1** must be folded up and secured with rubber strap **2**.

**6.23 Steering lock (All EU models)**



Steering lock **1** is fitted on the left side of the steering head. The steering lock is used to lock the steering. Steering, and therefore riding, is no longer possible.

**6.24 Locking the steering (All EU models)**

**Note**

**Danger of damage** The parked vehicle can roll away or fall over.

- Park the vehicle on a firm and level surface.



- Park the vehicle.
- Turn handlebar as far as possible to the right.
- Insert the key for the steering lock into the steering lock, turn it to the left, press it in, and turn it to the right. Pull out the key for the steering lock.
- ✓ Steering is no longer possible.



**Info**

Never leave the key for the steering lock in the steering lock.



**6.25 Unlocking the steering (All EU models)**

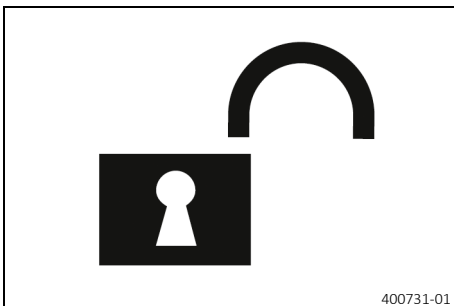

- Insert the key for the steering lock into the steering lock, turn it to the left, pull it out, and turn it to the right. Pull out the key for the steering lock.
- ✓ The handlebar can now be moved again.



**Info**

Never leave the key for the steering lock in the steering lock.



# 7 COMBINATION INSTRUMENT

## 7.1 Combination instrument overview

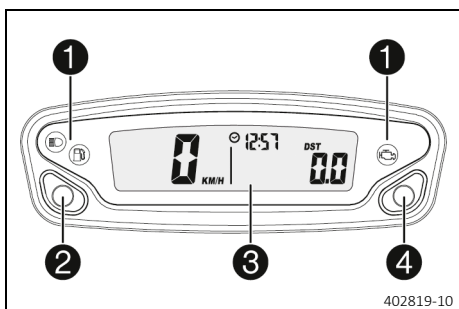

- 1 Overview of indicator lamps
- 2 Left button
- 3 Display
- 4 Right button

## 7.2 Activation

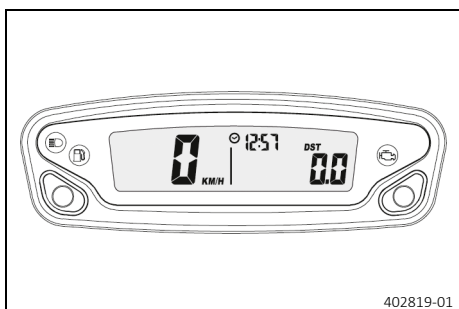

### Activating combination instrument

The combination instrument is activated when one of the buttons is pressed or an impulse comes from the wheel speed sensor.

## 7.3 Messages on the combination instrument

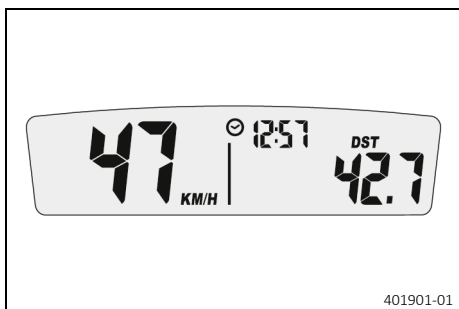

### Possible states

	Battery voltage of the combination instrument – The battery voltage of the combination instrument is too low. Change combination instrument battery.
	Service – A service is due. Contact an authorized GAS-GAS Motorcycles workshop.

## 7.4 Setting the combination instrument

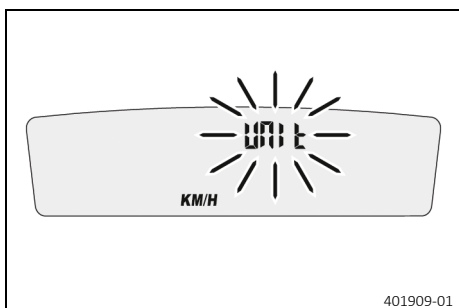

### Condition

The motorcycle is stationary.

- Press both buttons for 3–5 seconds.
  - ✓ The Setup menu is displayed. The **UNIT** display flashes.
- Press one of the buttons to select **UNIT** for the speed in kilometers **KM/H** or miles **M/H**.



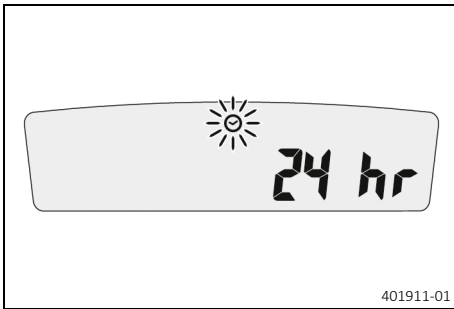

- Wait for 5 seconds.
- ✓ The combination instrument changes to the next menu item.  
The ☀ symbol flashes.
- Press one of the buttons to select the 24h or 12h display of the clock.

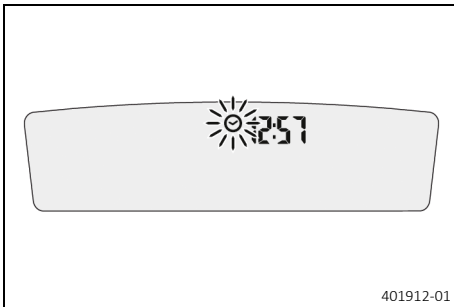

- Wait for 5 seconds.
- ✓ The combination instrument changes to the next menu item.  
The ☀ symbol flashes.

#### Resetting the time

- Press the left button.
- ✓ The value decreases.

#### Advancing the time

- Press the right button.
- ✓ The value increases.

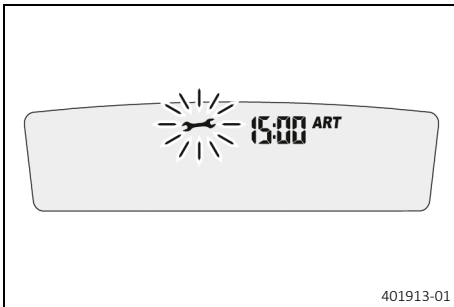

- Wait for 5 seconds.
- ✓ The combination instrument changes to the next menu item.  
The 🛠 symbol flashes.
- Set the service.

#### Shortening the service interval

- Press the left button.
- ✓ The value decreases.

#### Extending the service interval

- Press the right button.
- ✓ The value increases.

#### Switching off the service interval display

- Press and hold the left button.
- ✓ **off** appears in the display.

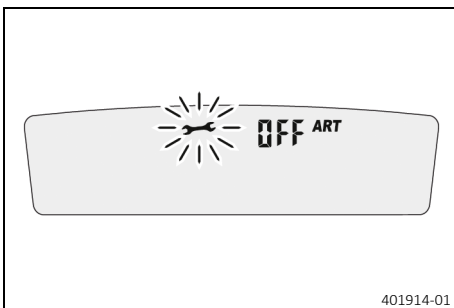

## 7.5 Setting the kilometers or miles



### Info

If the unit is changed, the value **ODO** is retained and converted accordingly.

### Condition

The motorcycle is stationary.

## 7 COMBINATION INSTRUMENT

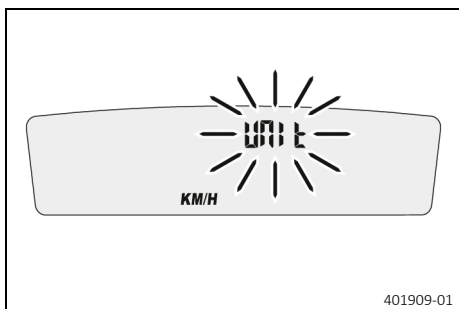

- Press both buttons for 3–5 seconds.
  - ✓ The Setup menu is displayed. The **UNIT** display flashes.
- Press one of the buttons to select **UNIT** for the speed in kilometers **KM/H** or miles **M/H**.

### 7.6 Setting the clock

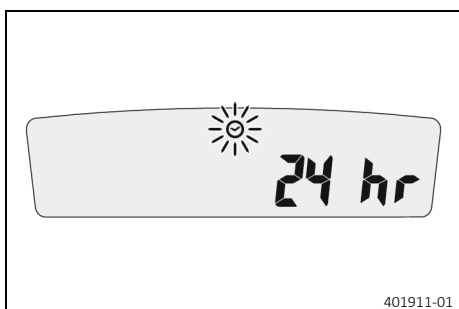

#### Condition

The motorcycle is stationary.

- Press both buttons for 3–5 seconds.
  - ✓ The Setup menu is displayed. The **UNIT** display flashes.
- Wait for the menu of the clock ☀ to flash.
- Press one of the buttons to select the 24h or 12h display of the clock.

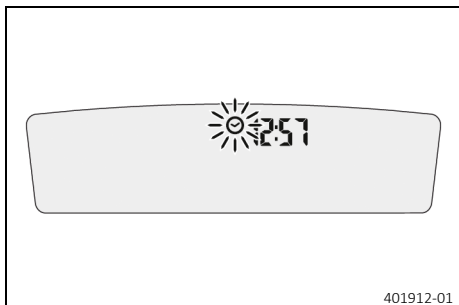

- Wait for 5 seconds.
  - ✓ The combination instrument changes to the next menu item. The ☀ symbol flashes.

#### Resetting the time

- Press the left button.
  - ✓ The value decreases.

#### Advancing the time

- Press the right button.
  - ✓ The value increases.

### 7.7 Setting the service display

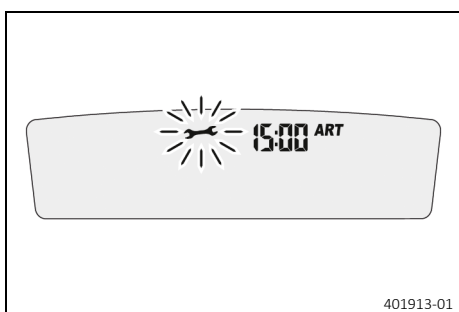

#### Condition

The motorcycle is stationary.

- Press both buttons for 3–5 seconds.
  - ✓ The Setup menu is displayed. The **UNIT** display flashes.
- Wait for the menu of the service display 🛠 to flash.
- Set the service.

#### Shortening the service interval

- Press the left button.
  - ✓ The value decreases.

#### Extending the service interval

- Press the right button.
  - ✓ The value increases.

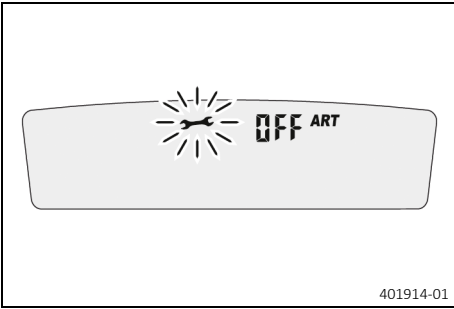

**Switching off the service interval display**

- Press and hold the left button.
- ✓ **off** appears in the display.

**7.8 Speed, time, and DST distance 1**

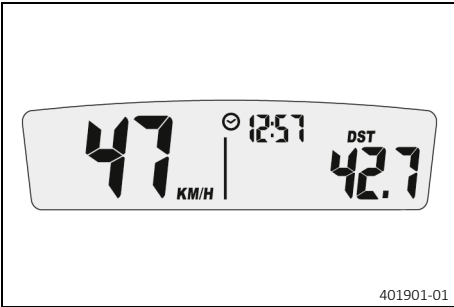

- Press one of the buttons until **DST** appears on the combination instrument.

**KM/H** or **M/H** shows the speed.

⌚ shows the time.

**DST** shows the distance since the last reset, such as between two refueling stops.

**i Info**  
If the value of 39999.9 is exceeded, **DST** is automatically reset to 0.0.

Press the left button briefly.	Next display mode
Press the left button for 3 – 5 seconds.	<b>DST</b> can be preset to a value between 0.0 and 39999.9 by pressing the buttons.
Press the right button briefly.	Next display mode
Press the right button for 3 – 5 seconds.	<b>DST</b> is reset to 0.0.

**7.9 Speed, time, and DST2 distance 2**

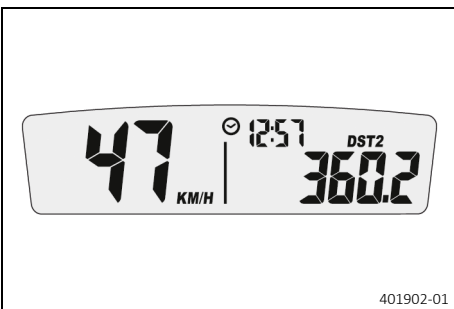

- Press one of the buttons until **DST2** appears on the combination instrument.

**KM/H** or **M/H** shows the speed.

⌚ shows the time.

**DST2** shows the distance 2 since the last reset, such as between two refueling stops.

**i Info**  
If the value of 39999.9 is exceeded, **DST2** is automatically reset to 0.0.

Press the left button briefly.	Next display mode
Press the left button for 3 – 5 seconds.	<b>DST2</b> can be preset to a value between 0.0 and 39999.9 by pressing the buttons.
Press the right button briefly.	Next display mode

Press the right button for 3 – 5 seconds.	<b>DST2</b> is reset to 0.0.
---	------------------------------

## 7.10 AVG average speed, ART operating hours, and ODO total distance covered

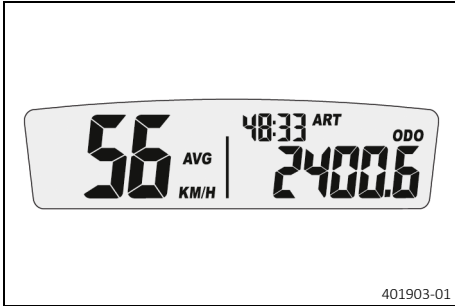

- Press one of the buttons until **AVG**, **ART** and **ODO** appear on the combination instrument.

**AVG** shows the average speed since the last reset.

**ART** shows the operating hours.

**ODO** shows the total distance covered.

Press the left button briefly.	Next display mode
Press the left button for 3 – 5 seconds.	The OPEN END WRENCH SYMBOL shows the remaining operating hours until the next service is due.
Press the right button briefly.	Next display mode
Press the right button for 3 – 5 seconds.	<b>AVG</b> is reset to 0.0.

## 8.1 Advice on preparing for first use



### Danger

- Danger of accidents** A rider who is not fit to ride poses a danger to him or herself and others.
- Do not operate the vehicle if you are not fit to ride due to alcohol, drugs or medication.
  - Do not operate the vehicle if you are physically or mentally impaired.



### Warning

- Risk of injury** Missing or poor protective clothing presents an increased safety risk.
- Wear appropriate protective clothing such as helmet, boots, gloves as well as trousers and a jacket with protectors on all rides.
  - Always wear protective clothing that is in good condition and meets the legal regulations.



### Warning

- Danger of crashing** Different tire tread patterns on the front and rear wheel impair the handling characteristic. Different tire tread patterns can make the vehicle significantly more difficult to control.
- Make sure that only tires with a similar tire tread pattern are fitted to the front and rear wheel.



### Warning

- Danger of accidents** An unadapted riding style impairs the handling characteristic.
- Adapt your riding speed to the road conditions and your riding ability.



### Warning

- Danger of accidents** The vehicle is not designed to carry passengers.
- Do not ride with a passenger.



### Warning

- Danger of accidents** The brake system fails in the event of overheating. If the foot brake lever is not released, the brake linings drag continuously.
- Take your foot off the foot brake lever if you do not want to brake.



### Warning

- Danger of accidents** Total weight and axle loads influence the handling characteristic.
- Do not exceed the maximum permissible overall weight or the axle loads.



### Warning

- Risk of misappropriation** People who act without authorization endanger themselves and others.
- Do not leave the vehicle unattended if the engine is running.
  - Protect the vehicle against access by unauthorized persons.



### Info

When using your motorcycle, remember that others may feel disturbed by excessive noise.

- Make sure that the pre-sales inspection work has been carried out by an authorized GASGAS Motorcycles workshop.
  - ✓ You will receive a delivery certificate when the vehicle is handed over.
- Before riding for the first time, read the entire Owner's Manual carefully.
- Get to know the controls.
- Adjust the basic position of the clutch lever. (📖 p. 79)

#### (All EU models)

- Adjust the free travel of the handbrake lever.

## (EC 300 US)

- Adjust the basic position of the hand brake lever. (📖 p. 82)
- Adjust the basic position of the foot brake lever. 🏍️ (📖 p. 88)
- Adjust the basic position of the shift lever. 🏍️ (📖 p. 122)
- Get used to handling the motorcycle on a suitable surface before undertaking a more challenging trip.



### Info

When offroad, it is recommended that you are accompanied by another person on another vehicle so that you can help each other.

- Try also to ride as slowly as possible and in a standing position to get a better feel for the motorcycle.
- Do not make any off-road trips that exceed your ability and experience.
- Hold the handlebar firmly with both hands and keep your feet on the footrests when riding.
- If you carry luggage, make sure you secure it firmly as close as possible to the center of the vehicle and ensure even weight distribution between the front and rear wheels.



### Info

Motorcycles react sensitively to any changes of weight distribution.

- The maximum permissible overall weight and the maximum permissible axle loads must not be exceeded.

#### Guideline

Maximum permissible overall weight	335 kg (739 lb.)
Maximum permissible front axle load	145 kg (320 lb.)
Maximum permissible rear axle load	190 kg (419 lb.)

- Check the spoke tension. (📖 p. 98)



### Info

The spoke tension must be checked after half an hour of operation.

- Run the engine in. (📖 p. 28)

## 8.2 Running in the engine

- During the running-in phase, do not exceed the specified engine performance.

#### Guideline

Maximum engine performance	
During the first 3 operating hours	< 70 %
During the first 5 operating hours	< 100 %

- Avoid fully opening the throttle!
- Check the idle speed regularly.

#### Guideline

Idle speed	1,400 ... 1,500 rpm
------------	---------------------



### Info

The idle speed may change during the run-in time.

- » If the idle speed changes:
  - Adjust the idle speed. 🏍️ (📖 p. 119)

**8.3 Starting power of lithium-ion batteries at low temperatures**

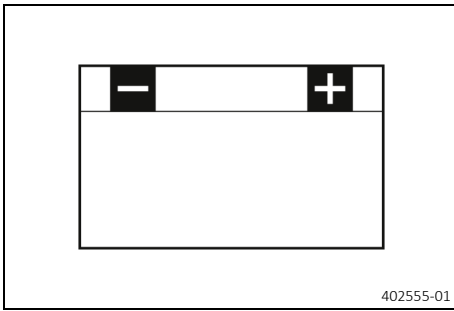

Lithium-ion batteries are far lighter than lead batteries, have a low self-discharge rate, and have more starting power at temperatures over 15 °C (60 °F). At low temperatures, however, the starting power of lithium-ion batteries drops to below that of lead batteries. Multiple starting attempts may be needed. Press the start button for 5 seconds, and wait 30 seconds between attempts. The pauses are necessary so that the heat created can distribute through the lithium-ion battery and the 12-V battery is not damaged. If the charged lithium-ion battery is unable to actuate the starter motor when temperatures are below 15 °C (60 °F), the battery is not faulty, but needs to be warmed up internally to increase its starting power (current output). The starting power increases as the battery warms up.

**8.4 Preparing the vehicle for difficult riding conditions**

**i Info** Use of the vehicle under difficult conditions, such as on sand or on wet and muddy surfaces, can lead to considerably more rapid wear of components such as the drive train, brake system, or suspension components. For this reason, it may be necessary to inspect or replace parts before the next scheduled service.

- Seal the air filter box. 🛠️
- Clean the air filter and air filter box. 🛠️ (📖 p. 67)

**i Info** Check the air filter approx. every 30 minutes.

- Check the electrical connector for humidity and corrosion and to ensure it is firmly seated.
  - » If humidity, corrosion, or damage is found:
    - Clean and dry the connector, or change it if necessary.

**Difficult riding conditions are:**

- Rides on dry sand. (📖 p. 29)
- Rides on wet sand. (📖 p. 31)
- Rides on wet and muddy circuits. (📖 p. 32)
- Rides at high temperatures or slow riding. (📖 p. 32)
- Riding at low temperatures and in snow. (📖 p. 33)



**8.5 Preparing the vehicle for rides on dry sand**



- Check the radiator cap.

Value on the radiator cap	1.8 bar (26 psi)
---------------------------	------------------

- » If the indicated value does not correspond to the setpoint value:



## Warning

**Danger of scalding** During motorcycle operation, the coolant gets very hot and is under pressure.

- Do not open the radiator, the radiator hoses or other cooling system components if the engine or the cooling system are at operating temperature.
- Allow the cooling system and the engine to cool down before you open the radiator, the radiator hoses or other components of the cooling system.
- In the event of scalding, rinse the area affected immediately with lukewarm water.



M01104-01

- Change the radiator cap.
- Mount the air filter dust cover.

Air filter dust cover (79006920000)



## Info

Observe the **GASGAS Technical Accessories** fitting instructions.



M01105-01

- Mount the air filter sand cover.

Air filter sand cover (79006922000)



## Info

Observe the **GASGAS Technical Accessories** fitting instructions.



600868-01

- Clean the chain.

Chain cleaner (📖 p. 151)

- Mount the steel sprocket.
- Grease the chain.

Universal oil spray (📖 p. 152)

- Clean the radiator fins.
- Straighten the bent radiator fins carefully.

## Condition

Regular use in sand

- Change the piston every 10 operating hours.



**8.6 Preparing the vehicle for rides on wet sand**



- Check the radiator cap.

Value on the radiator cap	1.8 bar (26 psi)
---------------------------	------------------

» If the indicated value does not correspond to the setpoint value:



**Warning**

**Danger of scalding** During motorcycle operation, the coolant gets very hot and is under pressure.

- Do not open the radiator, the radiator hoses or other cooling system components if the engine or the cooling system are at operating temperature.
- Allow the cooling system and the engine to cool down before you open the radiator, the radiator hoses or other components of the cooling system.
- In the event of scalding, rinse the area affected immediately with lukewarm water.

- Change the radiator cap.



- Mount the air filter rain cover.

Air filter rain cover (79006921000)
-------------------------------------



**Info**

Observe the **GASGAS Technical Accessories** fitting instructions.



- Clean the chain.

Chain cleaner (📖 p. 151)
--------------------------

- Mount the steel sprocket.
- Grease the chain.

Universal oil spray (📖 p. 152)
--------------------------------

- Clean the radiator fins.
- Straighten the bent radiator fins carefully.

**Condition**

Regular use in sand

- Change the piston every 10 operating hours.



## 8.7 Preparing the vehicle for rides on wet and muddy circuits



- Mount the air filter rain cover.

Air filter rain cover (79006921000)
-------------------------------------



### Info

Observe the **GASGAS Technical Accessories** fitting instructions.



- Mount the steel sprocket.
- Clean the motorcycle. (🔧 p. 132)
- Straighten the bent radiator fins carefully.

## 8.8 Preparing vehicle for high temperatures or slow riding



- Check the radiator cap.

Value on the radiator cap	1.8 bar (26 psi)
---------------------------	------------------

» If the indicated value does not correspond to the setpoint value:



### Warning

**Danger of scalding** During motorcycle operation, the coolant gets very hot and is under pressure.

- Do not open the radiator, the radiator hoses or other cooling system components if the engine or the cooling system are at operating temperature.
- Allow the cooling system and the engine to cool down before you open the radiator, the radiator hoses or other components of the cooling system.
- In the event of scalding, rinse the area affected immediately with lukewarm water.

- Change the radiator cap.

- Adjust the secondary drive to the road conditions.



### Info

The transmission oil heats up quickly when the clutch is operated frequently due to an excessively high secondary drive.

- Clean the chain.

Chain cleaner (🔧 p. 151)
--------------------------

- Clean the radiator fins.

- Straighten bent radiator fins carefully.
- Check the coolant level. (📖 p. 112)



**8.9 Preparing the vehicle for low temperatures or snow**



- Mount the air filter rain cover.

Air filter rain cover (79006921000)

**i Info**  
Observe the **GASGAS Technical Accessories** fitting instructions.



## 9.1 Checks and maintenance measures when preparing for use

### **i** Info

Before every trip, check the condition of the vehicle and ensure that it is safe to operate. The vehicle must be in perfect technical condition when it is being operated.

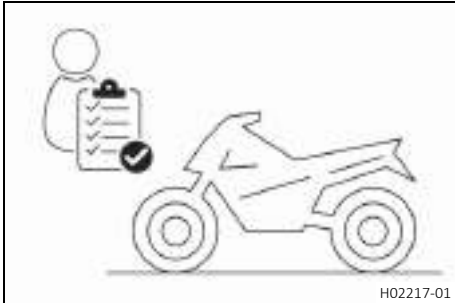

- Check the gear oil level. (📖 p. 128)
- Check the electrical system.
- Check the front brake fluid level. (📖 p. 83)
- Check the rear brake fluid level. (📖 p. 88)
- Check the front brake linings. (📖 p. 85)
- Check the brake linings of the rear brake. (📖 p. 90)
- Check that the brake system is functioning properly.
- Check the coolant level. (📖 p. 112)
- Check the chain for dirt. (📖 p. 73)
- Check the chain, rear sprocket, engine sprocket, and chain guide. (📖 p. 75)
- Check the chain tension. (📖 p. 74)
- Check the tire condition. (📖 p. 97)
- Check tire pressure. (📖 p. 97)
- Check the spoke tension. (📖 p. 98)

### **i** Info

The spoke tension must be checked regularly as incorrect spoke tension will strongly impair riding safety.

- Clean the dust boots of the fork legs. (📖 p. 53)
- Bleed the fork legs. (📖 p. 52)
- Check the air filter.
- Check the settings of all controls and ensure that they can be operated smoothly.
- Check all screws, nuts, and hose clamps regularly for tightness.
- Check the fuel level.
- Check 2-stroke oil level. (📖 p. 124)

## 9.2 Starting the vehicle



### **Danger**

**Danger of poisoning** Exhaust gases are toxic and inhaling them may result in unconsciousness and death.

- Always make sure there is sufficient ventilation when running the engine.
- Use effective exhaust extraction when starting or running the engine in an enclosed space.

### **Note**

**Engine damage** High revving speed with a cold engine negatively impacts the lifespan of the engine.

- Always run the engine warm at a low speed.

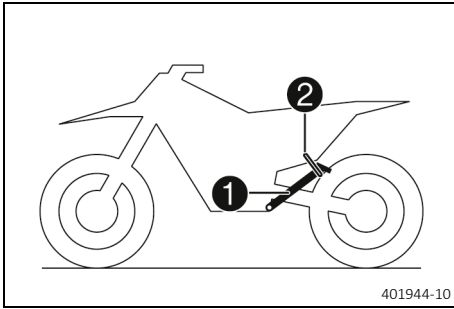

- Take the motorcycle off side stand ① and secure the side stand with rubber strap ②.
- Shift the transmission to neutral position.

**Condition**

Ambient temperature: < 10 °C (< 50 °F)

- Pull the cold start button fully out and turn it by a ¼ turn.



**Info**

If the engine is warm, the cold start button must be deactivated.

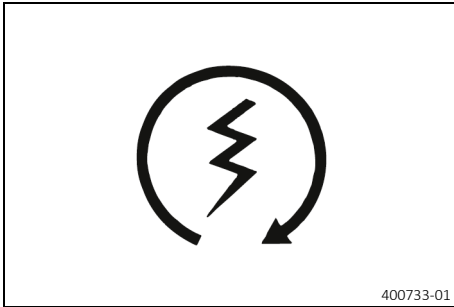

- Press the start button.



**Info**

Do not open the throttle.  
 Press the start button for a maximum of 5 seconds. Wait for 30 seconds before a further attempt at starting.  
 At temperatures below 15 °C (60 °F), several attempts at starting may be necessary to warm-up the lithium-ion battery and thereby increase the starting power.  
 During the starting process, the malfunction indicator lamp lights up.

## 9.3 Starting off



**Info**

Switch on the light before riding the vehicle. You will be seen earlier by other motorists.  
 When you are riding, the side stand must be folded up and secured with the rubber strap.

- Pull the clutch lever, shift into first gear, release the clutch lever slowly and at the same time open the throttle carefully.

## 9.4 Shifting, riding



**Warning**

**Danger of accidents** If you change down at high engine speed, the rear wheel blocks and the engine races.

- Do not change into a low gear at high engine speed.



**Warning**

**Engine failure** The engine will not be lubricated unless there is 2-stroke oil in the oil tank.

If the oil level warning light lights up, the 2-stroke oil is sufficient for the remaining tank of fuel.

- As soon as the oil level warning light lights up, ride for no longer than until the remaining fuel in the tank is depleted.
- At the next opportunity add 2-stroke oil before you refuel.
- Time the oil pump if the 2-stroke oil hose has been removed or the 2-stroke oil tank has been fully depleted in error.



**Info**

If you hear unusual noises while riding, stop immediately, switch off the engine, and contact an authorized GAS-GAS Motorcycles workshop.  
 First-gear is used for starting off and for steep inclines.

- Shift into a higher gear when conditions allow (incline, road situation, etc.). To do so, release the throttle while simultaneously pulling the clutch lever, shift into the next gear, release the clutch lever and open the throttle.
- If the cold start function was activated, deactivate the cold start button after the engine has warmed up.
- After reaching maximum speed by fully opening the throttle grip, turn the throttle back so it is  $\frac{3}{4}$  open. This will barely reduce the speed, but fuel consumption will be considerably lower.
- Always open the throttle only as much as the engine can handle – abrupt throttle opening increases fuel consumption.
- To shift down, apply the brakes and close the throttle at the same time.
- Pull the clutch lever and shift into a lower gear, release the clutch lever slowly, and either open the throttle or shift again.
- Switch off the engine if running at idle speed or stationary for a long time.

Guideline

$\geq 2$  min

- Avoid frequent and longer slipping of the clutch. This causes the gear oil, engine and cooling system to heat up.
- Ride at a low engine speed instead of at a high engine speed with a slipping clutch.

### 9.5 Braking



#### Warning

**Danger of accidents** Excessively forceful application of the brakes blocks the wheels.

- Adjust application of the brakes to the respective riding situation and riding surface conditions.



#### Warning

**Danger of accidents** A spongy pressure point on the front or rear brake reduces braking efficiency.

- Check the brake system and do not continue riding until the problem is eliminated. (Your authorized GAS-GAS Motorcycles workshop will be glad to help.)



#### Warning

**Danger of accidents** Moisture and dirt impair the brake system.

- Brake carefully several times to dry out and remove dirt from the brake linings and the brake discs.

- On sandy, wet or slippery surfaces, use the rear brake.
- Braking should always be completed before you go into a bend. Change down to a lower gear appropriate to your road speed.

### 9.6 Stopping, parking



#### Warning

**Risk of misappropriation** People who act without authorization endanger themselves and others.

- Do not leave the vehicle unattended if the engine is running.
- Protect the vehicle against access by unauthorized persons.



#### Warning

**Danger of burns** Some vehicle components become very hot when the vehicle is operated.

- Do not touch any parts such as the exhaust system, radiator, engine, shock absorber, or brake system before the vehicle parts have cooled down.
- Let the vehicle parts cool down before you perform any work on the vehicle.

#### Note

**Material damage** The vehicle may be damaged by incorrect procedure when parking.

Significant damage may be caused if the vehicle rolls away or falls over.  
The components for parking the vehicle are designed only for the weight of the vehicle.

- Park the vehicle on a firm and level surface.
- Ensure that nobody sits on the vehicle when the vehicle is parked on a stand.

#### Note

**Fire hazard** Hot vehicle components pose a fire hazard and explosion risk.

- Do not park the vehicle near to materials which are highly flammable or explosive.
- Allow the vehicle to cool down before covering it.

- Apply the brakes on the motorcycle.
- Shift the transmission to neutral position.

#### (All EU models)

- Press and hold the stop button  while the engine is idling until the engine stops.

#### (EC 300 US)

- Press and hold the stop button  while the engine is idling until the engine stops.
- Park the motorcycle on firm ground.



## 9.7 Transporting

#### Note

**Danger of damage** The parked vehicle can roll away or fall over.

- Park the vehicle on a firm and level surface.

#### Note

**Fire hazard** Hot vehicle components pose a fire hazard and explosion risk.

- Do not park the vehicle near to materials which are highly flammable or explosive.
- Allow the vehicle to cool down before covering it.

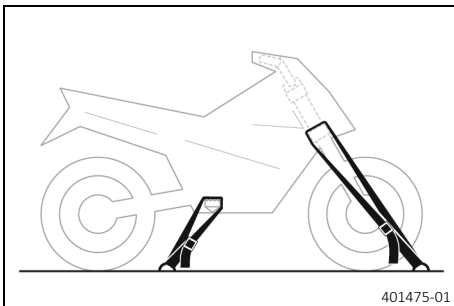

- Switch off the engine.
- Use tension belts or other suitable devices to secure the motorcycle against falling over or rolling away.

## 9.8 Refueling



#### Danger

**Fire hazard** Fuel is highly flammable.

The fuel in the fuel tank expands when warm and can escape if overfilled.

- Do not fuel the vehicle in the vicinity of open flames or lit cigarettes.
- Switch off the engine for refueling.
- Make sure that no fuel is spilled; particularly not on hot parts of the vehicle.
- If any fuel is spilled, wipe it off immediately.
- Observe the specifications for refueling.



## Warning

**Danger of poisoning** Fuel is poisonous and a health hazard.

- Avoid skin, eye and clothing contact with fuel.
- Immediately consult a doctor if you swallow fuel.
- Do not inhale fuel vapors.
- In case of skin contact, rinse the affected area with plenty of water.
- Rinse the eyes thoroughly with water, and consult a doctor in case of fuel contact with the eyes.
- Change your clothing in case of fuel spills on them.

## Note

**Material damage** Inadequate fuel quality causes the fuel filter to quickly become clogged.

In some countries and regions, the available fuel quality and cleanliness may not be sufficient. This will result in problems with the fuel system.

- Refuel only with clean fuel that meets the specified standards. (Your authorized GASGAS Motorcycles workshop will be glad to help.)



## Note

**Environmental hazard** Improper handling of fuel is a danger to the environment.

- Do not allow fuel to enter the groundwater, the soil, or the sewage system.

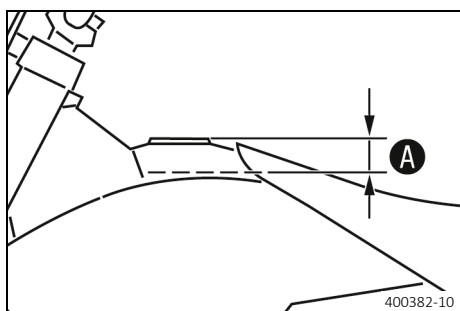

- Open the fuel tank filler cap. (📖 p. 17)
- Fill the fuel tank with fuel up to level **A**.

Guideline

Level <b>A</b>	35 mm (1.38 in)	
Total fuel tank capacity, approx.	8.5 l (2.25 US gal)	Super unleaded (ROZ 95) (📖 p. 150)



## Info

Do not refuel using pre-mixed fuel.

- Close the fuel tank filler cap. (📖 p. 18)

## 9.9 Adding 2-stroke oil



## Warning

**Engine failure** The engine will not be lubricated unless there is 2-stroke oil in the oil tank.

If the oil level warning light lights up, the 2-stroke oil is sufficient for the remaining tank of fuel.

- As soon as the oil level warning light lights up, ride for no longer than until the remaining fuel in the tank is depleted.
- At the next opportunity add 2-stroke oil before you refuel.
- Time the oil pump if the 2-stroke oil hose has been removed or the 2-stroke oil tank has been fully depleted in error.

- Open 2-stroke oil tank cap. (📖 p. 18)



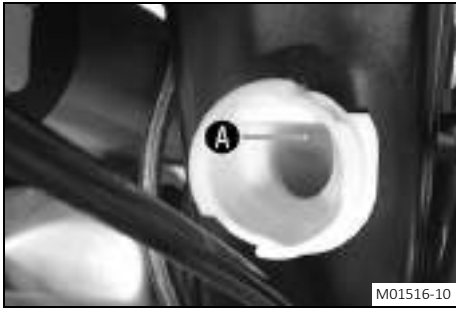

- Fill the 2-stroke oil tank up to the lower edge **A** of the filler neck.

Guideline

Only use 2-stroke oil which is appropriate for separate lubrication.

2-stroke oil tank content approx.	0.6 l (0.6 qt.)	Engine oil, 2-stroke (📖 p. 149)
-----------------------------------	-----------------	---------------------------------

- Close 2-stroke oil tank cap. (📖 p. 18)



































## 10.1 Additional information

Any further work that results from the compulsory work or from the recommended work must be ordered separately and invoiced separately.

Different service intervals may apply in your country, depending on the local operating conditions.

Individual service intervals and scopes may change in the course of technical developments. The most up-to-date service schedule can always be found on GASGAS Motorcycles Dealer.net. Your authorized GASGAS Motorcycles dealer will be glad to advise you.

## 10.2 Required work

	Every 10 operating hours when used for motorsports			Every 40 operating hours		
				Every 20 operating hours		
				After 5 operating hours		
				After 1 operating hour		
Read out the fault memory using the GASGAS Motorcycles diagnostics tool. 	○	○	●	●	●	●
Check that the electrical system is functioning properly.	○		●	●	●	●
Check and charge the 12-V battery. 			●	●	●	●
Check the front brake linings. (  p. 85)			●	●	●	●
Check the brake linings of the rear brake. (  p. 90)			●	●	●	●
Check the brake discs. (  p. 82)			●	●	●	●
Check the brake lines for damage and leakage.			●	●	●	●
Check the rear brake fluid level. (  p. 88)			●	●	●	●
Check the free travel of the foot brake lever. (  p. 87)			●	●	●	●
Check the frame.  (  p. 78)			●	●	●	●
Check the link fork.  (  p. 78)			●	●	●	●
Checking the fork bearing for play. 			●	●		
Checking the shock absorber heim joint for play. 			●	●		
Check the shock absorber linkage. 			●	●		
Check the tire condition. (  p. 97)	○		●	●	●	●
Check tire pressure. (  p. 97)	○		●	●	●	●
Check the wheel bearing for play. 			●	●	●	●
Check the wheel hubs. 			●	●	●	●
Check the rim run-out. 	○		●	●		
Check the spoke tension. (  p. 98)	○		●	●	●	●
Check the chain, rear sprocket, engine sprocket, and chain guide. (  p. 75)			●	●	●	●
Check the chain tension. (  p. 74)	○		●	●	●	●
Grease all moving parts (e.g. side stand, hand lever, chain, etc.) and check for smooth operation. 			●	●	●	●
Check/correct the fluid level of the hydraulic clutch. (  p. 79)			●	●	●	●
Check the front brake fluid level. (  p. 83)			●	●	●	●
Check the free travel of the hand brake lever. (  p. 82)			●	●	●	●
Check steering head bearing play. (  p. 58)	○		●	●		
Change the spark plug and spark plug connector. 					●	
Check the reed valve housing, reed valve and intake flange. 			●	●		
Change the gear oil.  (  p. 129)		○			●	
Check all hoses (e.g. fuel, cooling, bleeder, drainage, etc.) and sleeves for cracking, leaks, and incorrect routing. 	○		●	●	●	●

	Every 10 operating hours when used for motorsports		
	Every 40 operating hours		
	Every 20 operating hours		
	After 5 operating hours		
	After 1 operating hour		
Check the antifreeze and coolant level. (📖 p. 111)	○	●	●
Check the cables for damage and for routing without kinks. 🛠️		●	●
Check that the throttle cables are undamaged, routed without sharp bends, and set correctly.	○	●	●
Clean the air filter and air filter box. 🛠️ (📖 p. 67)		●	●
Change the glass fiber yarn filling of the main silencer. 🛠️ (📖 p. 69)		●	●
Service the fork. 🛠️			●
Perform the shock absorber service. 🛠️			●
Check the tightness of the easily accessible, safety-relevant screws and nuts. 🛠️	○	●	●
Change the fuel screen. 🛠️ (📖 p. 123)	○	●	●
Check the fuel pressure. 🛠️		●	●
Check the headlight setting. (📖 p. 108)	○	●	●
Check the idle speed. 🛠️		●	●
Final check: Check the vehicle for operating safety and take a test ride. 🛠️	○	○	●
Read out the fault memory after the test ride using the GASGAS Motorcycles diagnostics tool. 🛠️	○	○	●
Make a service entry in <b>GASGAS Motorcycles Dealer.net</b> . 🛠️	○	○	●

- One-time interval
- Periodic interval

**10.3 Recommended work**

	Every 40 operating hours when used for motorsports		
	Every 10 operating hours when used for motorsports		
	every 48 months		
	every 12 months		
	Every 80 operating hours		
	Every 40 operating hours		
	After 20 operating hours		
	After 10 operating hours		
Change the front brake fluid. 🛠️		●	●
Change the rear brake fluid. 🛠️		●	●
Change the hydraulic clutch fluid. 🛠️ (📖 p. 80)		●	●
Lubricate the steering head bearing. 🛠️ (📖 p. 60)		●	●
Clean the pressure sensor hose. 🛠️		●	●
Service the fork. 🛠️	○		
Perform the shock absorber service. 🛠️	○		
Check the electric starter drive. 🛠️		●	●
Change the fuel filter. 🛠️		●	●
Change the piston and check the cylinder. 🛠️		●	●
Change the oil pump; clean the oil screen. 🛠️		●	
Clean the oil screen in the oil tank. 🛠️		●	
Clean the protection cap of the pressure sensor. 🛠️		●	●
Change the coolant. 🛠️ (📖 p. 115)			●

# 10 SERVICE SCHEDULE

	After 10 operating hours	After 20 operating hours	Every 40 operating hours	Every 80 operating hours	every 12 months	every 48 months
Perform minor engine service. (Check the exhaust control for functioning and smooth operation. Check the clutch.) 🛠️			•	•		•
Perform major engine service including removing and installing the engine. (Change the connecting rod, conrod bearing, and crank pin. Clean the hose connections of the pressure sensor. Check the transmission and shift mechanism. Change all engine bearings.) 🛠️				•		•

- One-time interval
- Periodic interval

**11.1 Checking the basic chassis setting with the rider's weight**

**Info** When adjusting the basic chassis setting, first adjust the shock absorber and then the fork.

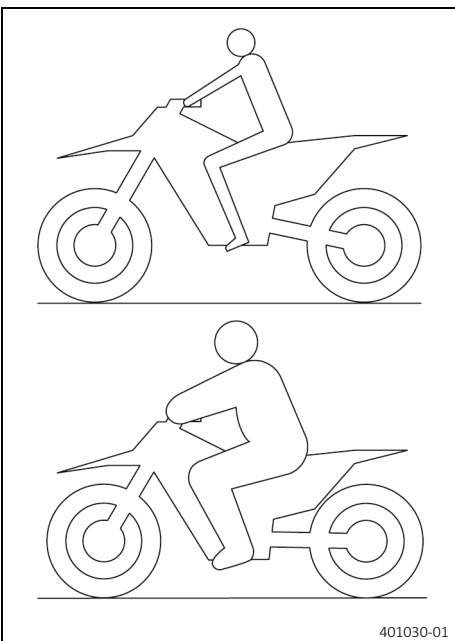

- For optimal motorcycle riding characteristics and to avoid damage to forks, shock absorbers, link fork and frame, the basic settings of the suspension components must match the rider's weight.
- As delivered, GASGAS offroad motorcycles are adjusted for an average rider's weight (with full protective clothing).

Guideline

Standard rider weight	75 ... 85 kg (165 ... 187 lb.)
-----------------------	--------------------------------

- If the rider's weight is above or below this range, the basic setting of the suspension components must be adjusted accordingly.
- Small weight differences can be compensated by adjusting the spring preload, but in the case of large weight differences, the springs must be replaced.

**11.2 Compression damping of the shock absorber**

The compression damping of the shock absorber is divided into two ranges: high-speed and low-speed. High-speed and low-speed refer to the compression speed of the rear wheel suspension and not to the vehicle speed. The high-speed compression adjuster has an effect, for example, when landing after a jump: the rear wheel suspension compresses quickly. The low-speed compression adjuster has an effect, for example, when riding over long ground swells: the rear wheel suspension compresses slowly. These two ranges can be adjusted separately, although the transition between high-speed and low-speed is gradual. Thus, modifications in the high-speed range affect the compression damping in the low-speed range and vice versa.

**11.3 Adjusting the low-speed compression damping of the shock absorber**

**Caution**  
**Risk of injury** Parts of the shock absorber will move around if the shock absorber is detached incorrectly. The shock absorber is filled with highly compressed nitrogen.  
 - Please follow the description provided. (Your authorized GASGAS Motorcycles workshop will be glad to help.)

**Info** The effect of the low-speed compression adjuster can be seen in slow to normal compression of the shock absorber.

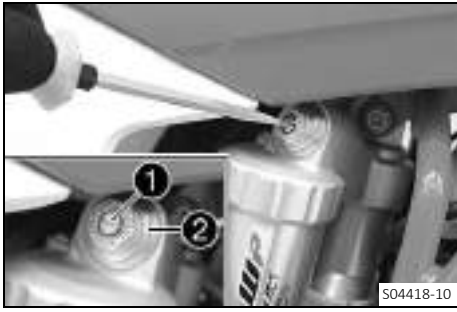

- Turn adjusting screw **1** clockwise with a screwdriver as far as the last perceptible click.

**i Info**

Do not loosen fitting **2**!

- Turn counterclockwise by the number of clicks corresponding to the shock absorber type.

Guideline

Lowspeed compression damping	
Comfort	17 clicks
Standard	15 clicks
Sport	13 clicks

**i Info**

Turn clockwise to increase damping; turn counterclockwise to reduce damping.

## 11.4 Adjusting the high-speed compression damping of the shock absorber



### Caution

**Risk of injury** Parts of the shock absorber will move around if the shock absorber is detached incorrectly. The shock absorber is filled with highly compressed nitrogen.

- Please follow the description provided. (Your authorized GASGAS Motorcycles workshop will be glad to help.)



### Info

The effect of the high-speed compression adjuster can be seen in fast compression of the shock absorber.



- Using an open end wrench, turn adjusting screw **1** clockwise all the way.

**i Info**

Do not loosen fitting **2**!

- Turn counterclockwise by the number of turns corresponding to the shock absorber type.

Guideline

Highspeed compression damping	
Comfort	2.5 turns
Standard	2 turns
Sport	1.5 turns

**i Info**

Turn clockwise to increase damping; turn counterclockwise to reduce damping.

**11.5 Adjusting the rebound damping of the shock absorber**



**Caution**

**Risk of injury** Parts of the shock absorber will move around if the shock absorber is detached incorrectly. The shock absorber is filled with highly compressed nitrogen.

- Please follow the description provided. (Your authorized GASGAS Motorcycles workshop will be glad to help.)



- Turn adjusting screw ① clockwise up to the last perceptible click.
- Turn counterclockwise by the number of clicks corresponding to the shock absorber type.

Guideline

Rebound damping	
Comfort	17 clicks
Standard	15 clicks
Sport	13 clicks



**Info**

Turn clockwise to increase the damping; turn counterclockwise to reduce damping when the shock absorber rebounds.



**11.6 Measuring the dimension of the rear wheel unloaded**

**Preparatory work**

- Raise the motorcycle with a lift stand. (📖 p. 52)

**Main work**

- Position the sag gage in the rear axle and measure the distance to marking **SAG** on the rear fender.

Sag gauge (00029090100)
Pin, sag scale (00029990010)

- Note the value as dimension ①.

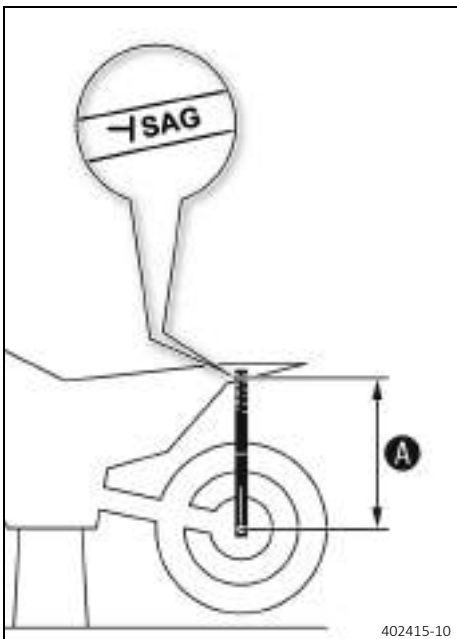

**Finishing work**

- Remove the motorcycle from the lift stand. (📖 p. 52)



## 11.7 Checking the static sag of the shock absorber

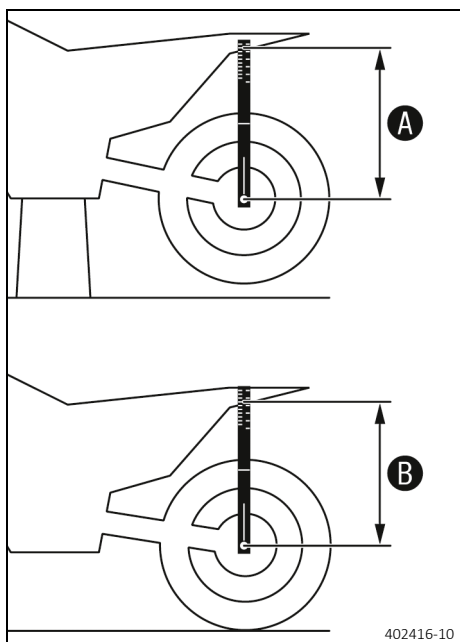

- Measure dimension **A** of rear wheel unloaded. (📖 p. 45)
- Hold the motorcycle upright with aid of an assistant.
- Measure the distance again between the rear axle and marking **SAG** on the rear fender using the sag gage.
- Note the value as dimension **B**.

### **i** Info

The static sag is the difference between measurements **A** and **B**.

- Check the static sag.

Static sag	37 mm (1.46 in)
------------	-----------------

- » If the static sag is less or more than the specified value:
  - Adjust the spring preload of the shock absorber. 🛠️ (📖 p. 47)

## 11.8 Checking the riding sag of the shock absorber

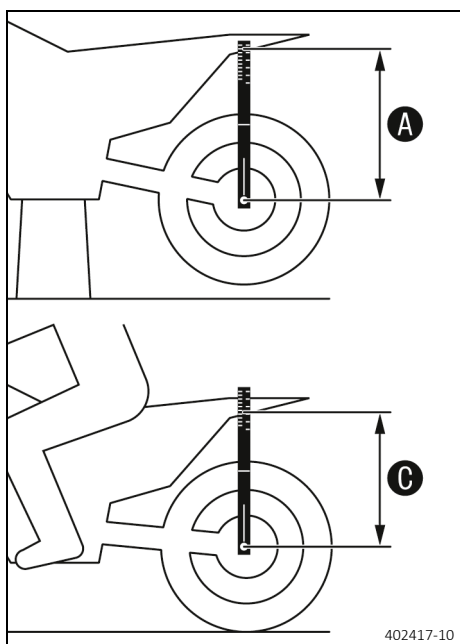

- Measure dimension **A** of rear wheel unloaded. (📖 p. 45)
- With another person holding the motorcycle, the rider, wearing full protective clothing, sits on the seat in a normal sitting position (feet on footrests) and bounces up and down a few times.
  - ✓ The rear wheel suspension levels out.
- Another person again measures the distance between the rear axle and marking **SAG** on the rear fender using the sag gage.
- Note the value as dimension **C**.

### **i** Info

The riding sag is the difference between measurements **A** and **C**.

- Check riding sag.

Riding sag	110 mm (4.33 in)
------------	------------------

- » If the riding sag differs from the specified measurement:
  - Adjust the riding sag. 🛠️ (📖 p. 48)



11.9 Adjusting the spring preload of the shock absorber

**Caution**  
**Risk of injury** Parts of the shock absorber will move around if the shock absorber is detached incorrectly. The shock absorber is filled with highly compressed nitrogen.  
 – Please follow the description provided. (Your authorized GASGAS Motorcycles workshop will be glad to help.)

**Info**  
 Before changing the spring preload, make a note of the present setting, e.g., by measuring the spring length.

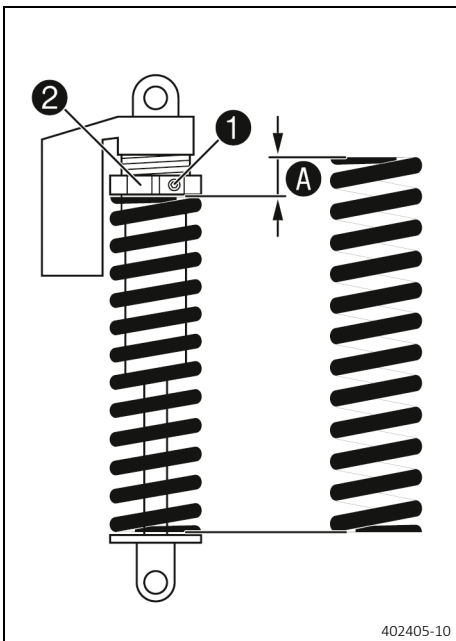

**Preparatory work**

- Raise the motorcycle with a lift stand. (p. 52)
- Remove the shock absorber. (p. 61)
- After removing the shock absorber, clean it thoroughly.

**Main work**

- Loosen screw 1.
- Turn adjusting ring 2 until the spring is no longer under tension.

Hook wrench (90129051000)

**Info**  
 If the spring cannot be fully released, the spring must be removed to accurately measure the spring length.

- Measure the total spring length while the spring is not under tension.
- Tension the spring by turning adjusting ring 2 to specified dimension A.

**Guideline**

Spring preload	10 mm (0.39 in)
----------------	-----------------

**Info**  
 Depending on the static sag and/or the riding sag, it may be necessary to increase or decrease the spring preload.

- Tighten screw 1.

**Guideline**

Screw, shock absorber adjusting ring	M5	5 Nm (3.7 lbf ft)
--------------------------------------	----	-------------------

**Finishing work**

- Install the shock absorber. (p. 63)
- Remove the motorcycle from the lift stand. (p. 52)

## 11.10 Adjusting the riding sag 🛠️

### Preparatory work

- Raise the motorcycle with a lift stand. (📖 p. 52)
- Remove the shock absorber. 🛠️ (📖 p. 61)
- After removing the shock absorber, clean it thoroughly.

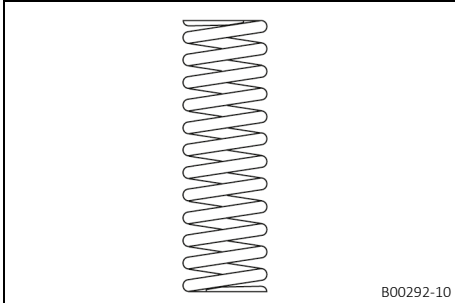

### Main work

- Choose and mount a suitable spring.

#### Guideline

Spring rate	
Weight of rider: 65 ... 75 kg (143 ... 165 lb.)	39 N/mm (223 lb/in)
Weight of rider: 75 ... 85 kg (165 ... 187 lb.)	42 N/mm (240 lb/in)
Weight of rider: 85 ... 95 kg (187 ... 209 lb.)	45 N/mm (257 lb/in)

### **i** Info

The spring rate is shown on the outside of the spring.

### Finishing work

- Install the shock absorber. 🛠️ (📖 p. 63)
- Remove the motorcycle from the lift stand. (📖 p. 52)
- Check the static sag of the shock absorber. (📖 p. 46)
- Check the riding sag of the shock absorber. (📖 p. 46)
- Adjust the rebound damping of the shock absorber. (📖 p. 45)

## 11.11 Checking the basic setting of the fork

### **i** Info

For various reasons, no exact riding sag can be determined for the fork.

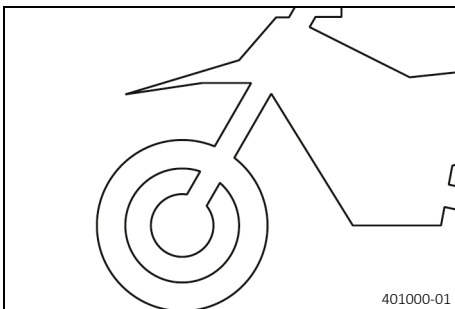

- As with the shock absorber, smaller differences in the rider's weight can be compensated by the spring preload.
- However, if the fork frequently bottoms out (hard end stop on compression), harder springs must be fitted to avoid damage to the fork and frame.
- If the fork feels unusually hard after extended periods of operation, the fork legs need to be bled.

**11.12 Adjusting the compression damping of the fork**

**i Info**

The hydraulic compression damping determines the fork suspension behavior.

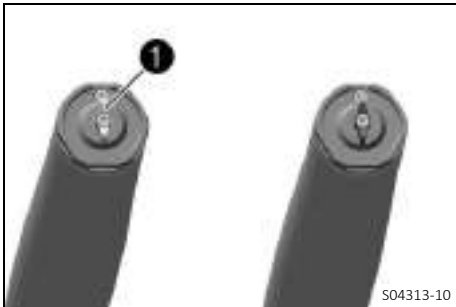

- Turn white adjuster ① clockwise as far as it will go.

**i Info**

Adjuster ① is located at the upper end of the left fork leg. The compression damping is located in left fork leg **COMP** (white adjuster). The rebound damping is located in right fork leg **REB** (red adjuster).

- Turn counterclockwise by the number of clicks corresponding to the fork type.

Guideline

Compression damping	
Comfort	18 clicks
Standard	15 clicks
Sport	12 clicks

**i Info**

Turn clockwise to increase damping; turn counterclockwise to reduce damping during compression.



**11.13 Adjusting the rebound damping of the fork**

**i Info**

The hydraulic rebound damping determines the fork suspension behavior.

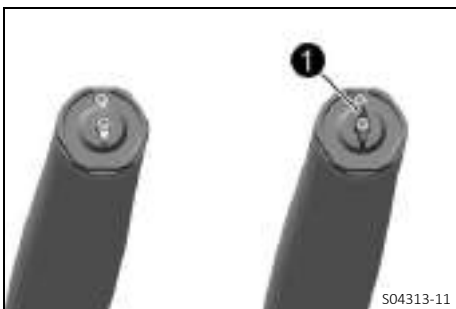

- Turn red adjuster ① clockwise as far as it will go.

**i Info**

Adjuster ① is located at the upper end of the right fork leg. The rebound damping is located in right fork leg **REB** (red adjuster). The compression damping is located in left fork leg **COMP** (white adjuster).

- Turn counterclockwise by the number of clicks corresponding to the fork type.

Guideline

Rebound damping	
Comfort	18 clicks
Standard	15 clicks
Sport	12 clicks

**i Info**

Turn clockwise to increase the damping; turn counterclockwise to reduce damping when the shock absorber rebounds.



## 11.14 Handlebar position

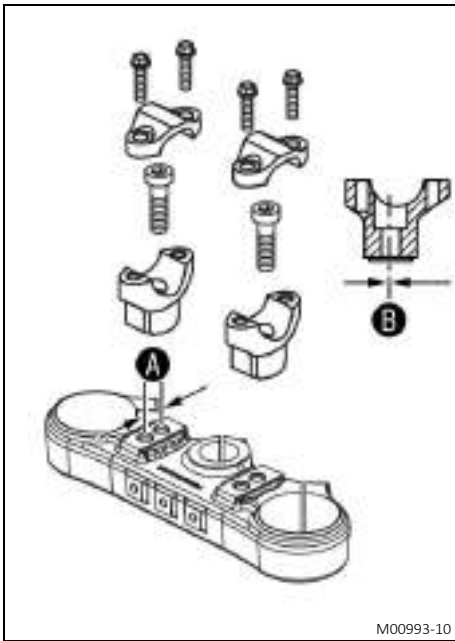

On the upper triple clamp, there are 2 holes at a distance of **A** to each other.

Hole distance A	15 mm (0.59 in)
-----------------	-----------------

The holes on the handlebar support are placed at a distance of **B** from the center.

Hole distance B	3.5 mm (0.138 in)
-----------------	-------------------

The handlebar can be mounted in four different positions. This allows the handlebar to be mounted in the most comfortable position for the rider.

## 11.15 Adjusting the handlebar position ↩



### Warning

**Danger of accidents** A repaired handlebar poses a safety risk.

If the handlebar is bent or straightened, the material becomes fatigued. The handlebar may break as a result.

- Change the handlebar if the handlebar is damaged or bent.

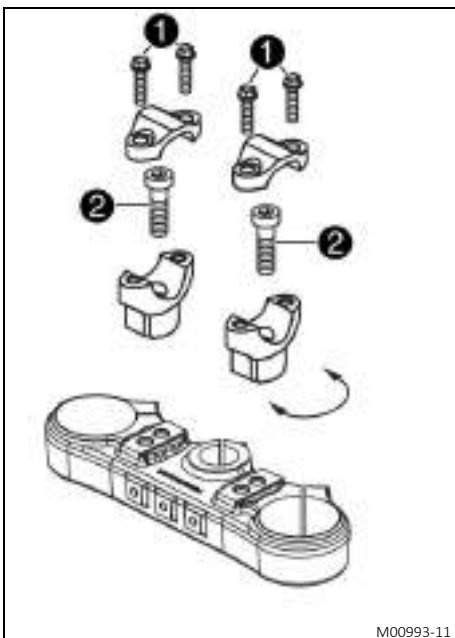

- Remove screws **1**. Take off the handlebar clamps. Remove the handlebar and lay it to one side.

### Info

Cover the components to protect them against damage. Do not kink the cables and lines.

- Remove screws **2**. Take off the handlebar supports.
- Place the handlebar supports in the required position. Mount and tighten screws **2**.

Guideline

Screw, handlebar support	M10	40 Nm (29.5 lbf ft) <b>Loctite®243™</b>
--------------------------	-----	--

### Info

Position the left and right handlebar supports evenly.

- Position the handlebar.

### Info

Make sure the cables and wiring are positioned correctly.

- Position the handlebar clamps. Mount screws ❶ and tighten evenly.

Guideline

Screw, handlebar clamp	M8	20 Nm (14.8 lbf ft)
------------------------	----	---------------------



**Info**

Make sure the gap widths are even.



## 12.1 Raising the motorcycle with a lift stand

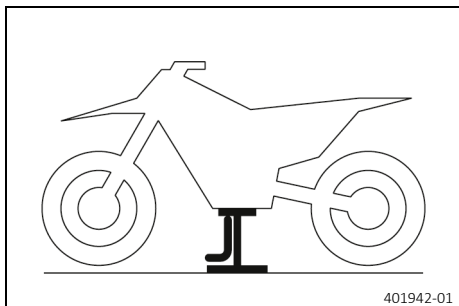

### Note

**Danger of damage** The parked vehicle can roll away or fall over.

- Park the vehicle on a firm and level surface.
- Raise the motorcycle at the frame underneath the engine.

Lift stand (A54029955100)

- ✓ Neither wheel is in contact with the ground.
- Secure the motorcycle against falling over.

## 12.2 Removing the motorcycle from the lift stand

### Note

**Danger of damage** The parked vehicle can roll away or fall over.

- Park the vehicle on a firm and level surface.

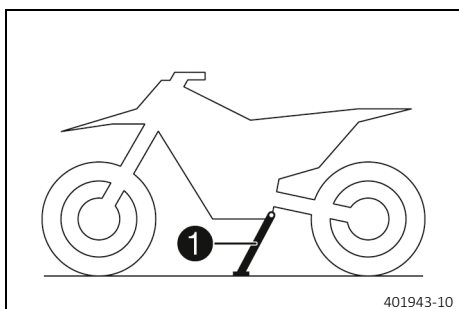

- Remove the motorcycle from the lift stand.
- Remove the lift stand.
- To park the motorcycle, press side stand ❶ to the ground with your foot and lean the motorcycle on it.

### Info

When you are riding, the side stand must be folded up and secured with the rubber strap.

## 12.3 Bleeding the fork legs

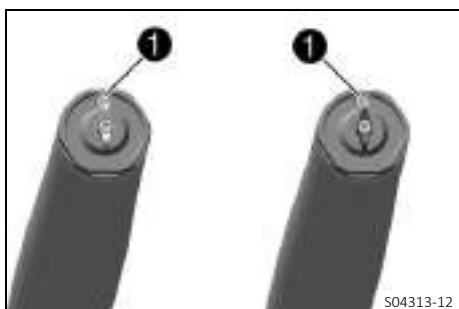

### Preparatory work

- Raise the motorcycle with a lift stand. (📖 p. 52)

### Main work

- Release bleeder screws ❶.
- ✓ Any excess pressure escapes from the interior of the fork.
- Tighten the bleeder screws.

### Finishing work

- Remove the motorcycle from the lift stand. (📖 p. 52)

## 12.4 Cleaning the dust boots of the fork legs



### Preparatory work

- Raise the motorcycle with a lift stand. (📖 p. 52)
- Remove the fork protector. (📖 p. 53)

### Main work

- Push dust boots ① of both fork legs downward.



### Info

The dust boots remove dust and coarse dirt particles from the inside fork tubes. Over time, dirt can accumulate behind the dust boots. If this dirt is not removed, the oil seals behind can start to leak.



### Warning

**Danger of accidents** Oil or grease on the brake discs reduces the braking effect.

- Always keep the brake discs free of oil and grease.
- Clean the brake discs with brake cleaner when necessary.

- Clean and oil the dust boots and inner fork tubes of both fork legs.

Universal oil spray (📖 p. 152)

- Press the dust boots back into their installation position.
- Remove excess oil.

### Finishing work

- Install the fork protector. (📖 p. 54)
- Remove the motorcycle from the lift stand. (📖 p. 52)



## 12.5 Removing the fork protector

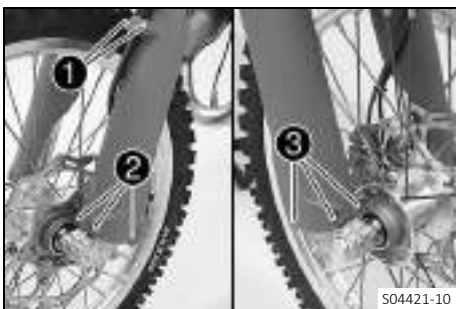

- Remove screws ① and take off the clamp.
- Remove screws ② and take off the left fork protector.
- Remove screws ③ and take off the right fork protector.



## 12.6 Installing the fork protector

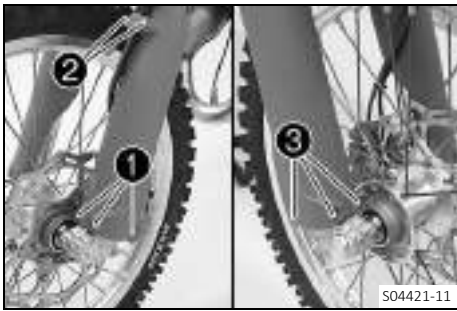

- Position the fork protector on the left fork leg. Mount and tighten screws **1**.

Guideline

Remaining screws, chassis	M6	10 Nm (7.4 lbf ft)
---------------------------	----	--------------------

- Position the brake line, wiring harness, and clamp. Mount and tighten screws **2**.
- Position the fork protector on the right fork leg. Mount and tighten screws **3**.

Guideline

Remaining screws, chassis	M6	10 Nm (7.4 lbf ft)
---------------------------	----	--------------------

## 12.7 Removing the fork legs

### Preparatory work

- Raise the motorcycle with a lift stand. (📖 p. 52)
- Remove the front wheel. (🔧 p. 93)
- Remove the headlight mask with the headlight. (📖 p. 106)

### Main work

- Remove screws **1** and take off the clamp.
- Remove the cable tie.
- Remove screws **2** and take off the brake caliper.
- Hang the brake caliper and the brake line loosely to the side.

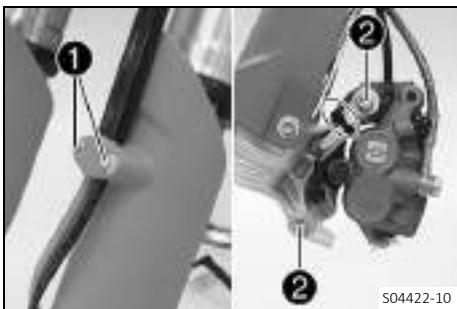

- Loosen screws **3**. Remove the left fork leg.
- Loosen screws **4**. Remove the right fork leg.

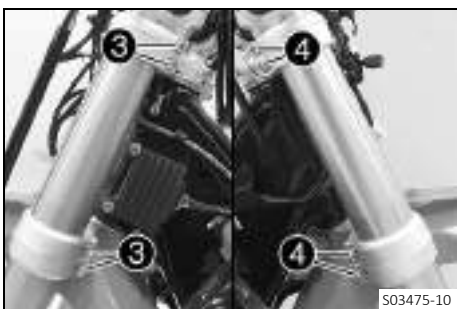



12.8 Installing the fork legs

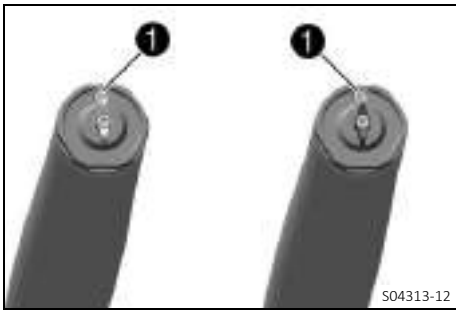

Main work

- Position the fork legs.
- ✓ Bleeder screws 1 are positioned toward the front.



Info

The rebound damping is located in right fork leg **REB** (red adjuster). The compression damping is located in left fork leg **COMP** (white adjuster). Grooves are milled into the side of the upper end of the fork legs. The second milled groove (from the top) must be flush with the upper edge of the upper triple clamp.

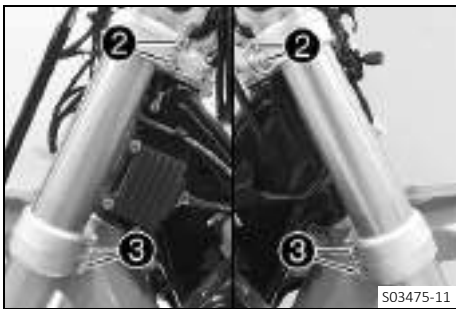

- Tighten screws 2.

Guideline

Screw, top triple clamp	M8	20 Nm (14.8 lbf ft)
-------------------------	----	---------------------

- Tighten screws 3.

Guideline

Screw, bottom triple clamp	M8	15 Nm (11.1 lbf ft)
----------------------------	----	---------------------

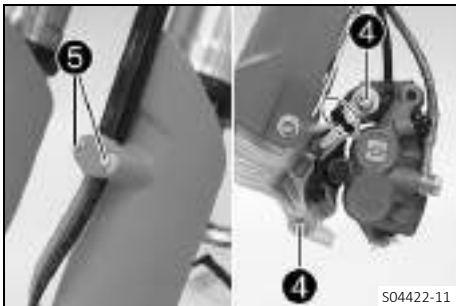

- Position the brake caliper, and mount and tighten screws 4.

Guideline

Screw, front brake caliper	M8	25 Nm (18.4 lbf ft) <b>Loctite®243™</b>
----------------------------	----	--

- Mount the cable ties.
- Position the brake line, the wiring harness, and the clamp. Mount and tighten screws 5.

Finishing work

- Install the front wheel. (📖 p. 94)
- Install the headlight mask with the headlight. (📖 p. 106)
- Check the headlight setting. (📖 p. 108)

12.9 Removing the lower triple clamp

Preparatory work

- Raise the motorcycle with a lift stand. (📖 p. 52)
- Remove the front wheel. (📖 p. 93)
- Remove the headlight mask with the headlight. (📖 p. 106)
- Remove the fork legs. (📖 p. 54)
- Remove front fender. (📖 p. 60)
- Remove the handlebar cushion.



### Main work

- Remove screws **1** and hang the combination instrument holder to the side.



- Remove screw **2**.
- Loosen screw **3**. Take off the upper triple clamp with the handlebar and hang them to the side.

### **i** Info

Cover the components to protect them against damage. Do not kink the cables and lines.

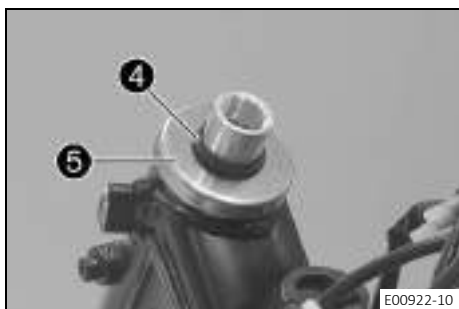

- Remove O-ring **4**. Remove protective ring **5**.
- Take off the lower triple clamp with the steering stem.
- Remove the upper steering head bearing.

## 12.10 Installing the lower triple clamp ↗

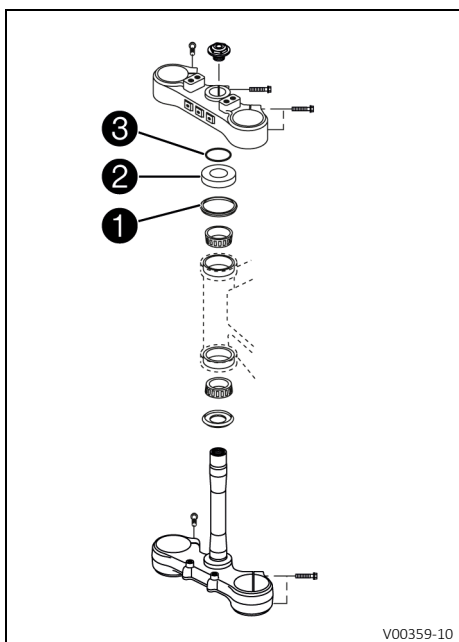

### Main work

- Clean the bearing and sealing elements, check for damage, and grease.

High viscosity grease (🔧 p. 151)

- Insert the lower triple clamp with the steering stem. Mount upper steering head bearing.
- Check whether upper steering head seal **1** is correctly positioned.
- Mount protective ring **2** and O-ring **3**.

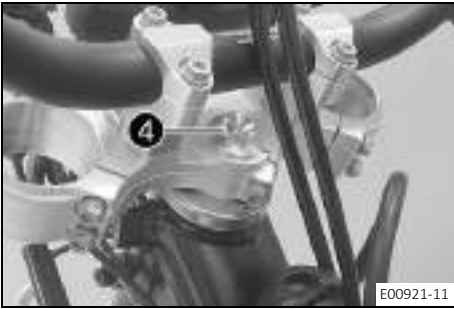

- Position the upper triple clamp with the handlebar.
- Position the clutch line and the wiring harness.
- Mount screw ④, but do not tighten yet.



- Position the combination instrument holder, and mount and tighten screws ⑤.

Guideline

Remaining screws, chassis	M6	10 Nm (7.4 lbf ft)
---------------------------	----	--------------------

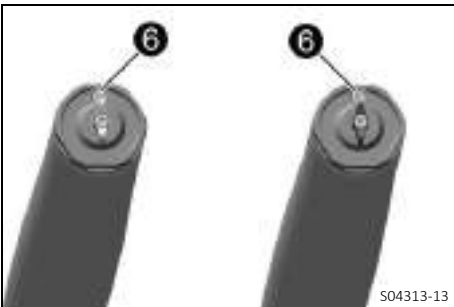

- Position the fork legs.
- ✓ Bleeder screws ⑥ are positioned toward the front.



### Info

The rebound damping is located in right fork leg **REB** (red adjuster). The compression damping is located in left fork leg **COMP** (white adjuster). Grooves are milled into the side of the upper end of the fork legs. The second milled groove (from the top) must be flush with the upper edge of the upper triple clamp.



- Tighten screws ⑦.

Guideline

Screw, bottom triple clamp	M8	15 Nm (11.1 lbf ft)
----------------------------	----	---------------------



- Tighten screw ④.

Guideline

Screw, top steering head	M20x1.5	12 Nm (8.9 lbf ft)
--------------------------	---------	--------------------



- Tighten screw 8.

Guideline

Screw, top steering stem	M8	20 Nm (14.8 lbf ft)
--------------------------	----	---------------------



- Tighten screws 9.

Guideline

Screw, top triple clamp	M8	20 Nm (14.8 lbf ft)
-------------------------	----	---------------------

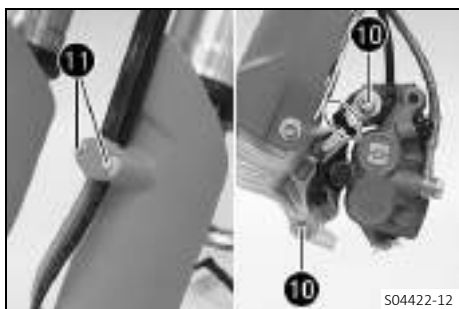

- Position the brake caliper, and mount and tighten screws 10.

Guideline

Screw, front brake caliper	M8	25 Nm (18.4 lbf ft) <b>Loctite®243™</b>
----------------------------	----	--

- Mount the cable ties.
- Position the brake line, the wiring harness, and the clamp. Mount and tighten screws 11.

### Finishing work

- Mount the handlebar cushion.
- Install front fender. (📖 p. 60)
- Install the front wheel. 🛠️ (📖 p. 94)
- Install the headlight mask with the headlight. (📖 p. 106)
- Check that the wiring harness, throttle cables, and brake and clutch lines can move freely and are routed correctly.
- Check steering head bearing play. (📖 p. 58)
- Remove the motorcycle from the lift stand. (📖 p. 52)
- Check the headlight setting. (📖 p. 108)

## 12.11 Checking steering head bearing play



### Warning

**Danger of accidents** Incorrect steering head bearing play impairs the handling characteristic and damages components.

- Correct incorrect steering head bearing play immediately. (Your authorized GASGAS Motorcycles workshop will be glad to help.)

**i Info**

If the vehicle is operated for a lengthy period with play in the steering head bearing, the bearings and the bearing seats in the frame can become damaged over time.

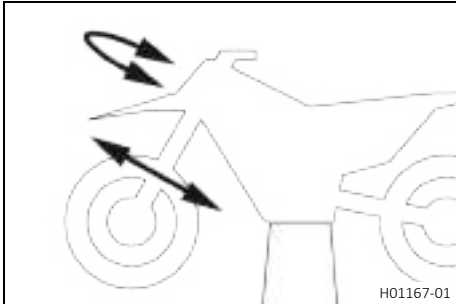

**Preparatory work**

- Raise the motorcycle with a lift stand. (📖 p. 52)

**Main work**

- Move the handlebar to the straight-ahead position. Move the fork legs to and fro in the direction of travel.

Play should not be detectable on the steering head bearing.

- » If there is detectable play:
  - Adjust the steering head bearing play. 🛠️ (📖 p. 59)

- Move the handlebar to and fro over the entire steering range.

It must be possible to move the handlebar easily over the entire steering range. There should be no detectable detent positions.

- » If detent positions are detected:
  - Adjust the steering head bearing play. 🛠️ (📖 p. 59)
  - Check the steering head bearing and change if necessary.

**Finishing work**

- Remove the motorcycle from the lift stand. (📖 p. 52)

**12.12 Adjusting the steering head bearing play 🛠️**



**Preparatory work**

- Raise the motorcycle with a lift stand. (📖 p. 52)

**Main work**

- Loosen screws ① and ②.
- Loosen and retighten screw ③.

Guideline

Screw, top steering head	M20x1.5	12 Nm (8.9 lbf ft)
--------------------------	---------	--------------------

- Using a plastic hammer, tap lightly on the upper triple clamp to avoid stresses.

- Tighten screws ①.

Guideline

Screw, top triple clamp	M8	20 Nm (14.8 lbf ft)
-------------------------	----	---------------------

- Tighten screw ②.

Guideline

Screw, top steering stem	M8	20 Nm (14.8 lbf ft)
--------------------------	----	---------------------

**Finishing work**

- Check steering head bearing play. (📖 p. 58)
- Remove the motorcycle from the lift stand. (📖 p. 52)

## 12.13 Lubricating the steering head bearing

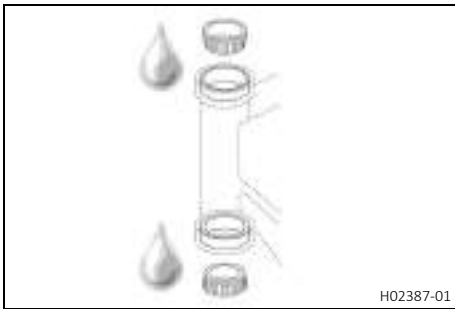

- Remove the lower triple clamp. (🔧 p. 55)
- Install the lower triple clamp. (🔧 p. 56)

## 12.14 Removing front fender

### Preparatory work

- Remove the headlight mask with the headlight. (🔧 p. 106)

### Main work

- Remove screws ❶.

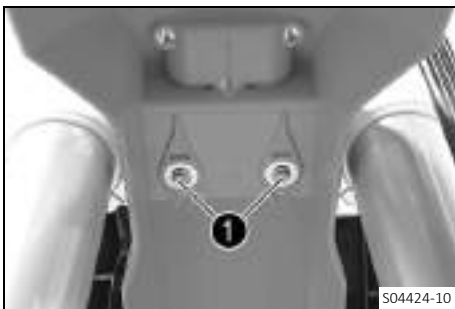

- Remove screws ❷. Take off front fender.



## 12.15 Installing front fender

### Main work

- Position front fender. Mount and tighten screws ❶.

#### Guideline

Remaining screws, chassis	M6	10 Nm (7.4 lbf ft)
------------------------------	----	--------------------



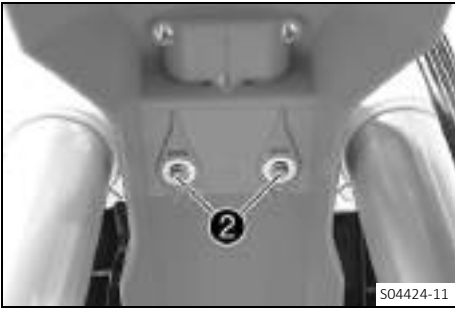

- Mount and tighten screws **2**.

Guideline

Remaining screws, chassis	M6	10 Nm (7.4 lbf ft)
------------------------------	----	--------------------

### Finishing work

- Install the headlight mask with the headlight. (📖 p. 106)
- Check the headlight setting. (📖 p. 108)



## 12.16 Removing the shock absorber 🛠️

### Preparatory work

- Raise the motorcycle with a lift stand. (📖 p. 52)

### Main work

- Remove the cable tie.
- Remove screws **1** and the frame protector.

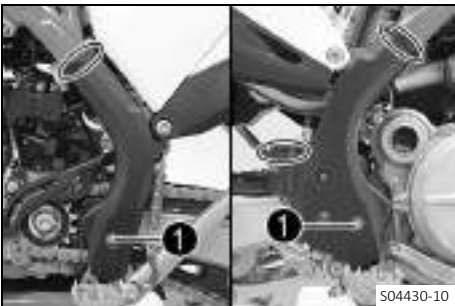

- Remove screw **2**.
- Remove fitting **3**.





---

**i Info**  
Raise the link fork slightly to be able to remove the screws more easily.

---

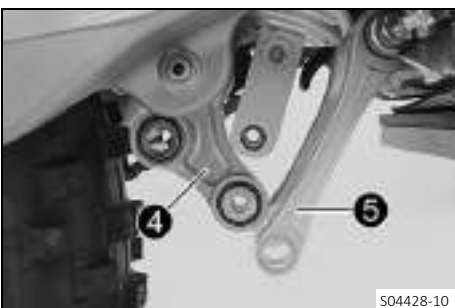
- Press angle lever **4** toward the rear.
- Press linkage lever **5** downward.





**(All EU models)**

- Disconnect plug-in connector 6 on the brake light switch.



- Remove screws 7.
- Pull off foot brake cylinder from the push rod.



- Remove the connecting link of the chain.



**Info**

Cover the components to protect them against damage.

- Take off the chain.

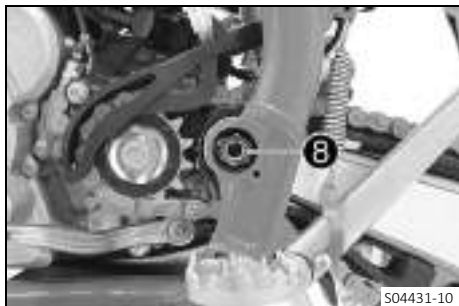

- Remove nut 8 and pull out the swingarm pivot.
- Push the link fork back and secure it against falling over.



- Hold the shock absorber and remove screw 9.
- Remove the shock absorber carefully at the bottom.



12.17 Installing the shock absorber ↩

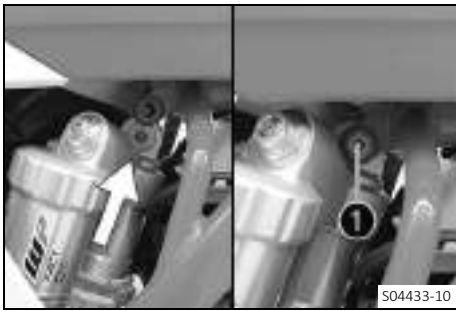

**Main work**

- Carefully position the shock absorber into the vehicle from the bottom.
- Mount and tighten screw ①.

Guideline

Screw, top shock absorber	M10	60 Nm (44.3 lbf ft) <b>Loctite®2701™</b>
---------------------------	-----	---

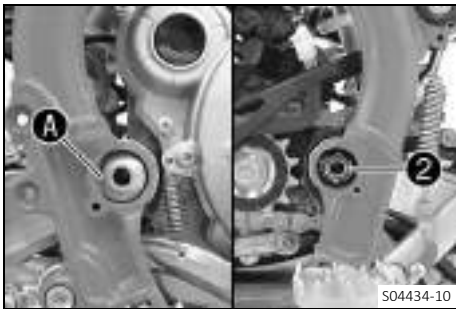

- Position the link fork and mount the swingarm pivot.

**i Info**

Pay attention to flat area A.

- Mount and tighten nut ②.

Guideline

Nut, fork pivot	M16x1.5	100 Nm (73.8 lbf ft)
-----------------	---------	----------------------



- Mount the chain.
- Connect the chain with the connecting link.

Guideline

The closed side of the chain joint lock must face in the direction of travel.



**(All EU models)**

- Join plug-in connector ③ of the brake light switch.



- Position the foot brake cylinder.
  - ✓ Push rod ④ engages in the foot brake cylinder.
  - ✓ The dust boot is correctly positioned.
- Mount and tighten screws ⑤.

Guideline

Remaining screws, chassis	M6	10 Nm (7.4 lbf ft)
---------------------------	----	--------------------

## 12 SERVICE WORK ON THE CHASSIS

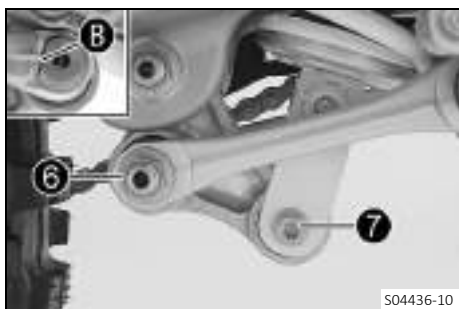

- Position the angle lever and linkage lever.
- Mount and tighten fitting **6**.

Guideline

Nut, linkage lever on angle lever	M14x1.5	60 Nm (44.3 lbf ft)
-----------------------------------	---------	---------------------



### Info

Pay attention to flat area **B**.

- Mount and tighten screw **7**.

Guideline

Screw, bottom shock absorber	M10	60 Nm (44.3 lbf ft) <b>Loctite® 2701™</b>
------------------------------	-----	--



### Info

Raise the link fork slightly to be able to mount the screw more easily.

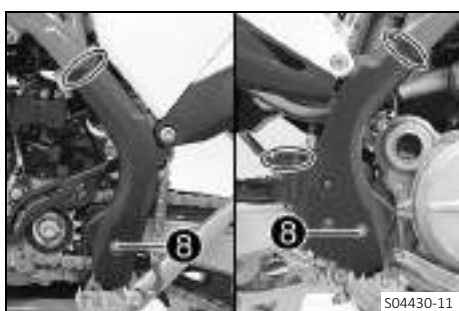

- Position the frame protector.
- Mount and tighten screws **8** with the washers.

Guideline

Screw, frame protector	M5	3 Nm (2.2 lbf ft)
------------------------	----	-------------------

- Mount the new cable ties.

### Finishing work

- Remove the motorcycle from the lift stand. (📖 p. 52)

## 12.18 Removing the seat



- Remove screw **1** on the left side.

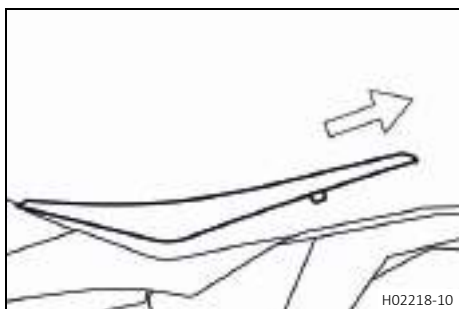

- Raise the rear of the seat, pull the seat back, and lift it off.

## 12.19 Mounting the seat

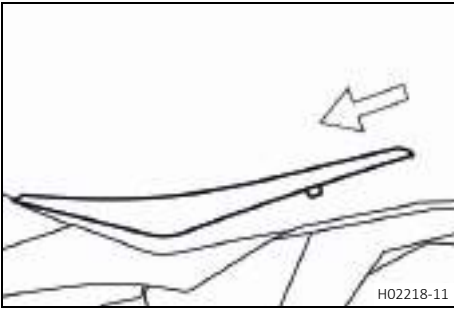

- Mount the front of the seat on the two collar bushings of the fuel tank, lower the seat at the rear, and push the seat forward.
- Make sure the seat is locked in correctly.



- Mount and tighten screw 1 on the left side.

Guideline

Remaining screws, chassis	M6	10 Nm (7.4 lbf ft)
---------------------------	----	--------------------

## 12.20 Removing the air filter box cover

### Preparatory work

- Remove the seat. (p. 64)



### Condition

The air filter box cover is secured.

- Remove screw 1.



- Pull off the air filter box cover in area A laterally and take it off at the front.

## 12.21 Installing the air filter box cover

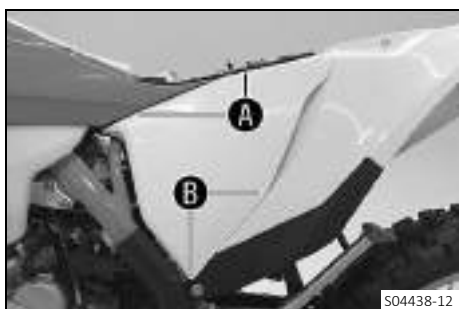

### Main work

- Insert the air filter box cover in area **A** and clip it into area **B**.



### Condition

The air filter box cover is secured.

- Mount and tighten screw **1**.

### Guideline

Screw, air filter box cover	<b>EJOT PT®</b> K60x20-Z	3 Nm (2.2 lbf ft)
-----------------------------	-----------------------------	-------------------

### Finishing work

- Mount the seat. (📖 p. 65)

## 12.22 Removing the air filter 🛠️

### Note

**Engine damage** Unfiltered intake air has a negative effect on the service life of the engine.

Dust and dirt will enter the engine without an air filter.

- Only operate the vehicle if it is equipped with an air filter.



### Note

**Environmental hazard** Hazardous substances cause environmental damage.

- Dispose of oils, grease, filters, fuel, cleaning agents, brake fluid, etc., correctly and in compliance with the applicable regulations.

### Preparatory work

- Remove the seat. (📖 p. 64)
- Remove the air filter box cover. (📖 p. 65)

### Main work

- Detach retaining tab **1**. Remove air filter with air filter support.
- Remove air filter from air filter support.



12.23 Installing the air filter

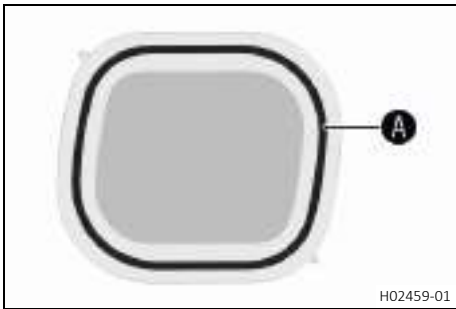

H02459-01

Main work

- Mount the clean air filter on the air filter support.
- Grease the air filter in area A.

Long-life grease (📖 p. 151)



S04444-10

- Insert air filter and position retaining pin 1 in bushing B.
- ✓ The air filter is correctly positioned.
- Insert retaining tab 2.
- ✓ Retaining pin 3 is secured with retaining tab 2.



Info

If the air filter is not mounted correctly, dust and dirt may enter the engine and result in damage.

Finishing work

- Install the air filter box cover. (📖 p. 66)
- Mount the seat. (📖 p. 65)



12.24 Cleaning the air filter and air filter box



Note

**Environmental hazard** Hazardous substances cause environmental damage.

- Dispose of oils, grease, filters, fuel, cleaning agents, brake fluid, etc., correctly and in compliance with the applicable regulations.



Info

Do not clean the air filter with fuel or petroleum since these substances attack the foam.

Preparatory work

- Remove the seat. (📖 p. 64)
- Remove the air filter box cover. (📖 p. 65)
- Remove the air filter. (🔧📖 p. 66)

Main work

- Wash the air filter thoroughly in special cleaning liquid and allow it to dry properly.

Air filter cleaner (📖 p. 151)



Info

Only press the air filter to dry it, never wring it out.

- Oil the dry air filter with a high-grade air filter oil.

Oil for foam air filter (📖 p. 151)



102191-01

- Clean the air filter box.
- Clean the intake flange and check it for damage and tightness.

### Finishing work

- Install the air filter. (📖 p. 67)
- Install the air filter box cover. (📖 p. 66)
- Mount the seat. (📖 p. 65)

## 12.25 Preparing air filter box cover for securing 🔧

### Preparatory work

- Remove the seat. (📖 p. 64)
- Remove the air filter box cover. (📖 p. 65)

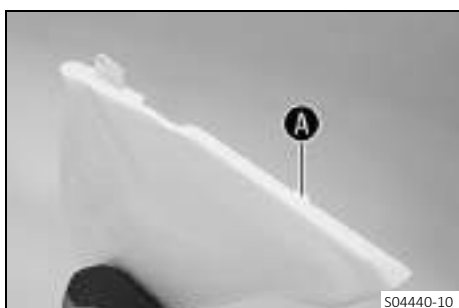

### Main work

- Drill a hole at marking **A**.

#### Guideline

Diameter	6 mm (0.24 in)
----------	----------------

### Finishing work

- Install the air filter box cover. (📖 p. 66)
- Mount the seat. (📖 p. 65)

## 12.26 Removing the main silencer



### Warning

**Danger of burns** The exhaust system gets very hot when the vehicle is driven.

- Allow the exhaust system to cool down before performing any work on the vehicle.

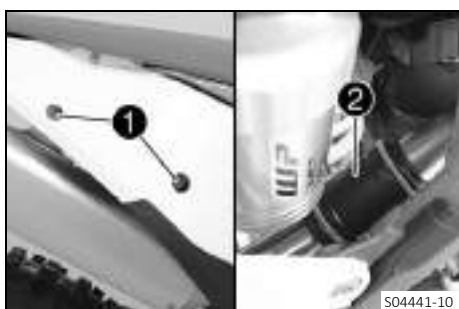

- Remove screws **1**.
- Pull off the main silencer with exhaust sleeve **2** and the spring ring from the manifold.

**12.27 Installing the main silencer**

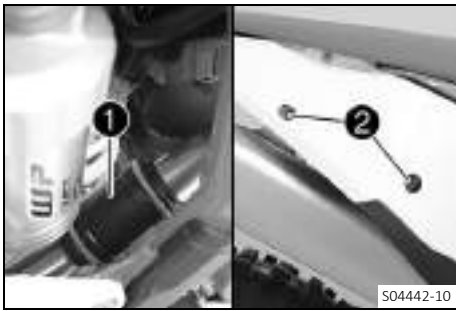

- Mount the main silencer with rubber sleeve ① and the spring rings.
- Mount and tighten screws ②.

Guideline

Remaining screws, chassis	M6	10 Nm (7.4 lbf ft)
---------------------------	----	--------------------



**12.28 Changing the glass fiber yarn filling of the main silencer**



**Warning**

**Danger of burns** The exhaust system gets very hot when the vehicle is driven.

- Allow the exhaust system to cool down before performing any work on the vehicle.



**Info**

Over time, the fibers of the glass fiber yarn filling escape and the damper "burns" out. Not only is the noise level higher, but the performance characteristics change.

**Preparatory work**

- Remove main silencer. (📖 p. 68)

**Main work**

- Remove screws ①. Pull out inner tube ② with O-ring ③.
- Pull glass fiber yarn filling ④ from the inner tube.
- Clean the parts that need to be reinstalled and check for damage.
- Mount new glass fiber yarn filling ④ on the inner tube.
- Push outer tube ⑤ over the inner tube with the new glass fiber yarn filling and the O-ring.
- Mount and tighten all screws ①.

Guideline

Screws on main silencer	M5	7 Nm (5.2 lbf ft)
-------------------------	----	-------------------

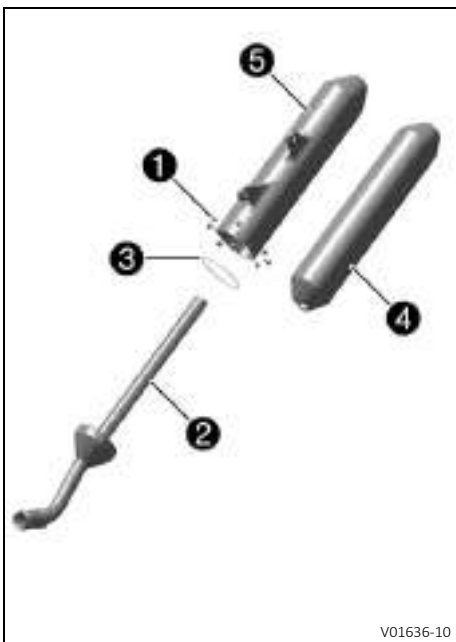

**Finishing work**

- Install the main silencer. (📖 p. 69)

## 12.29 Removing the fuel tank ↩



### Danger

**Fire hazard** Fuel is highly flammable.

The fuel in the fuel tank expands when warm and can escape if overfilled.

- Do not fuel the vehicle in the vicinity of open flames or lit cigarettes.
- Switch off the engine for refueling.
- Make sure that no fuel is spilled; particularly not on hot parts of the vehicle.
- If any fuel is spilled, wipe it off immediately.
- Observe the specifications for refueling.



### Warning

**Danger of poisoning** Fuel is poisonous and a health hazard.

- Avoid skin, eye and clothing contact with fuel.
- Immediately consult a doctor if you swallow fuel.
- Do not inhale fuel vapors.
- In case of skin contact, rinse the affected area with plenty of water.
- Rinse the eyes thoroughly with water, and consult a doctor in case of fuel contact with the eyes.
- Change your clothing in case of fuel spills on them.
- Keep fuels correctly in a suitable canister, and out of the reach of children.

### Preparatory work

- Remove the seat. (📖 p. 64)

### Main work

- Unplug connector ① of the fuel pump.
- Remove tube ② from the fuel tank breather.

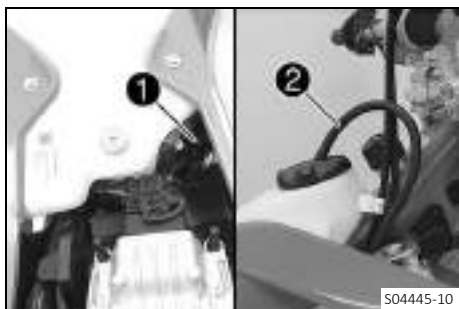

- Clean the quick release coupling thoroughly with compressed air.



### Info

Under no circumstances should dirt enter into the fuel line.  
Dirt in the fuel line clogs the injection valve!

- Disconnect the quick release coupling.



### Info

Remaining fuel may flow out of the fuel hose.

- Mount wash cap set ③.

Wash cap set (81212016100)



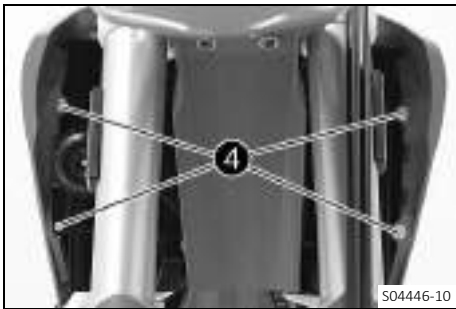

- Remove screws 4 with the collar bushings.
- (All EU models)**
- Hang the horn and horn bracket to one side.



- Remove screw 5 with the rubber bushing.



- Pull both spoilers off laterally from the radiator mount and lift off the fuel tank.

**12.30 Installing the fuel tank**

**Danger**  
**Fire hazard** Fuel is highly flammable.  
 The fuel in the fuel tank expands when warm and can escape if overfilled.

- Do not fuel the vehicle in the vicinity of open flames or lit cigarettes.
- Switch off the engine for refueling.
- Make sure that no fuel is spilled; particularly not on hot parts of the vehicle.
- If any fuel is spilled, wipe it off immediately.
- Observe the specifications for refueling.

**Warning**  
**Danger of poisoning** Fuel is poisonous and a health hazard.

- Avoid skin, eye and clothing contact with fuel.
- Immediately consult a doctor if you swallow fuel.
- Do not inhale fuel vapors.
- In case of skin contact, rinse the affected area with plenty of water.
- Rinse the eyes thoroughly with water, and consult a doctor in case of fuel contact with the eyes.
- Change your clothing in case of fuel spills on them.

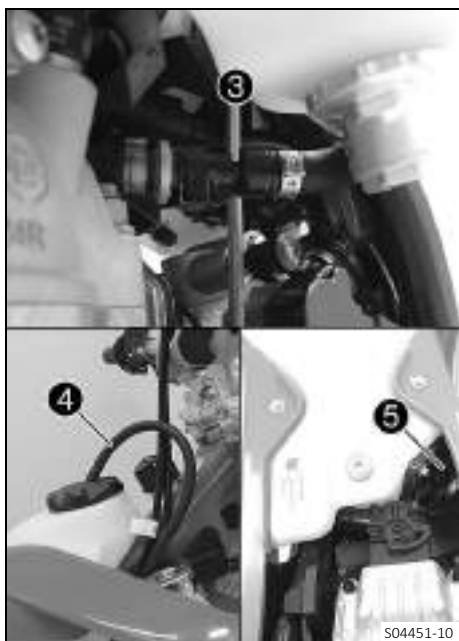

### Main work

- Check the throttle cable routing. (📖 p. 78)
- Position the fuel tank and fit the two spoilers to the sides in front of the radiator bracket.
- Make sure that no cables or throttle cables are trapped or damaged.

- Mount and tighten screw **1** with the rubber bushing.

#### Guideline

Remaining screws, chassis	M6	10 Nm (7.4 lbf ft)
---------------------------	----	--------------------

### (All EU models)

- Position the horn with the horn bracket.

- Mount and tighten screws **2** with the collar bushings.

#### Guideline

Remaining screws, chassis	M6	10 Nm (7.4 lbf ft)
---------------------------	----	--------------------

- Remove the wash cap set.
- Clean the quick release coupling thoroughly with compressed air.

### **i** Info

Under no circumstances should dirt enter into the fuel line. Dirt in the fuel line clogs the injection valve!

- Spray silicone spray onto a lint-free cleaning cloth and lightly lubricate the O-ring of the quick-release coupling.

Silicone spray (📖 p. 151)
---------------------------

- Join quick release coupling **3**.

### **i** Info

Route the cable and fuel line at a safe distance from the exhaust system.

- Attach fuel tank breather hose **4**.
- Plug in connector **5** for the fuel pump.

## Finishing work

- Mount the seat. (📖 p. 65)



### 12.31 Checking the chain for dirt

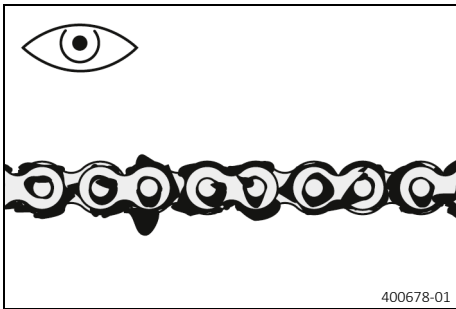

- Check the chain for heavy soiling.
  - » If the chain is very dirty:
    - Clean the chain. (📖 p. 73)



### 12.32 Cleaning the chain



#### Warning

**Danger of accidents** Lubricants on the tires reduces the road grip.

- Remove lubricants from the tires using a suitable cleaning agent.



#### Warning

**Danger of accidents** Oil or grease on the brake discs reduces the braking effect.

- Always keep the brake discs free of oil and grease.
- Clean the brake discs with brake cleaner when necessary.



#### Note

**Environmental hazard** Hazardous substances cause environmental damage.

- Dispose of oils, grease, filters, fuel, cleaning agents, brake fluid, etc., correctly and in compliance with the applicable regulations.



#### Info

The service life of the chain depends largely on its maintenance.

#### Preparatory work

- Raise the motorcycle with a lift stand. (📖 p. 52)

#### Main work

- Rinse off loose dirt with a soft jet of water.
- Remove old grease residue with chain cleaner.

Chain cleaner (📖 p. 151)

- After drying, apply chain spray.

Off-road chain spray (📖 p. 151)

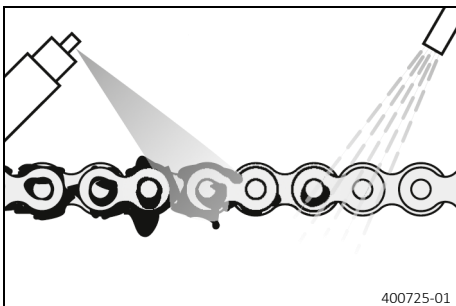

#### Finishing work

- Remove the motorcycle from the lift stand. (📖 p. 52)



## 12.33 Checking the chain tension



### Warning

**Danger of accidents** Incorrect chain tension damages components and results in accidents.

If the chain is tensioned too much, the chain, engine sprocket, rear sprocket, transmission and rear wheel bearings wear more quickly. Some components may break if overloaded.

If the chain is too loose, the chain may fall off the engine sprocket or the rear sprocket. As a result, the rear wheel locks or the engine will be damaged.

- Check the chain tension regularly.
- Set the chain tension in accordance with the specification.

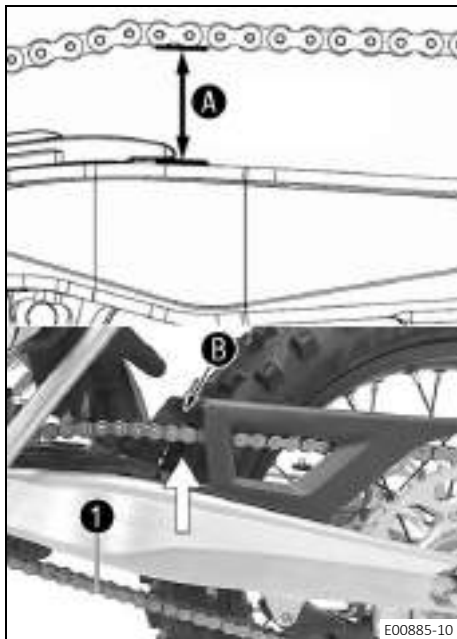

### Preparatory work

- Raise the motorcycle with a lift stand. (📖 p. 52)

### Main work

- Pull the chain at the end of the chain sliding piece upward to measure chain tension **A**.

### Info

Lower chain section **1** must be taut.

When the chain guard is mounted, it must be possible to pull up the chain at least to the point where it makes contact with chain guard **B**.

Chain wear is not always even, so you should repeat this measurement at different chain positions.

Chain tension	55 ... 58 mm (2.17 ... 2.28 in)
---------------	---------------------------------

» If the chain tension does not meet the specification:

- Adjust the chain tension. (📖 p. 74)

### Finishing work

- Remove the motorcycle from the lift stand. (📖 p. 52)

## 12.34 Adjusting the chain tension



### Warning

**Danger of accidents** Incorrect chain tension damages components and results in accidents.

If the chain is tensioned too much, the chain, engine sprocket, rear sprocket, transmission and rear wheel bearings wear more quickly. Some components may break if overloaded.

If the chain is too loose, the chain may fall off the engine sprocket or the rear sprocket. As a result, the rear wheel locks or the engine will be damaged.

- Check the chain tension regularly.
- Set the chain tension in accordance with the specification.

### Preparatory work

- Raise the motorcycle with a lift stand. (📖 p. 52)
- Check the chain tension. (📖 p. 74)

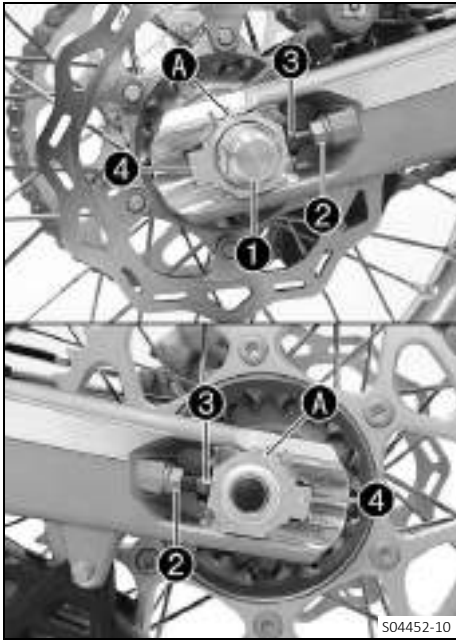

**Main work**

- Loosen nut ①.
- Loosen nuts ②.
- Adjust the chain tension by turning adjusting screws ③ left and right.

Guideline

Chain tension	55 ... 58 mm (2.17 ... 2.28 in)	
Turn adjusting screws ③ on the left and right so that the markings on the left and right chain adjusters are in the same position relative to reference marks A. The rear wheel is then correctly aligned.		

- Tighten nuts ②.
- Make sure that chain adjusters ④ are fitted correctly on adjusting screws ③.
- Tighten nut ①.

Guideline

Nut, rear wheel spindle	M20x1.5	80 Nm (59 lbf ft)
-------------------------	---------	-------------------



**Info**

The wide adjustment range of the chain adjusters (32 mm (1.26 in)) enables different secondary ratios with the same chain length.

Chain adjusters ④ can be turned by 180°.

**Finishing work**

- Remove the motorcycle from the lift stand. (📖 p. 52)



**12.35 Checking the chain, rear sprocket, engine sprocket, and chain guide**

**Preparatory work**

- Raise the motorcycle with a lift stand. (📖 p. 52)

**Main work**

- Shift the transmission into neutral.
- Check the chain, rear sprocket, and engine sprocket for wear.
  - » If the chain, rear sprocket or engine sprocket is worn:
    - Change the drivetrain kit. 🛠️

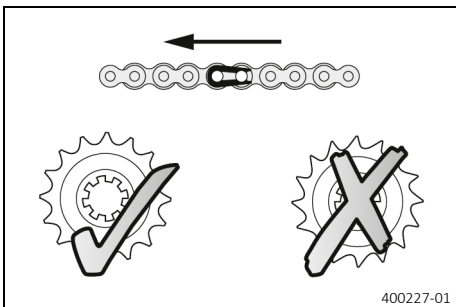

**Info**

The engine sprocket, rear sprocket, and chain should always be replaced together.

## 12 SERVICE WORK ON THE CHASSIS

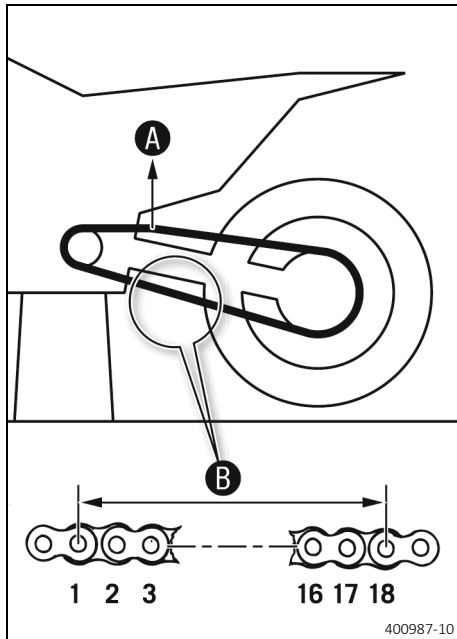

- Pull on the top section of the chain with the specified weight **A**.

Guideline

Weight, chain wear measurement	10 ... 15 kg (22 ... 33 lb.)
--------------------------------	------------------------------

- Measure distance **B** of 18 chain rollers in the lower chain section.



### Info

Chain wear is not always even, so you should repeat this measurement at different chain positions.

Maximum distance <b>B</b> from 18 chain rollers at the longest chain section	272 mm (10.71 in)
--	-------------------

- » If distance **B** is greater than the specified measurement:

- Change the drivetrain kit. 🛠️



### Info

When a new chain is mounted, the rear sprocket and engine sprocket should also be changed. New chains wear out faster on old, worn sprockets.



- Check the chain sliding guard for wear.
  - » If the lower edge of the chain pins is in line with, or below, the chain sliding guard:
    - Change the chain sliding guard. 🛠️

- Check that the chain sliding guard is firmly seated.

- » If the chain sliding guard is loose:

- Tighten screws on the chain sliding guard.

Guideline

Screw, chain sliding guard	M6	6 Nm (4.4 lbf ft) <b>Loctite®243™</b>
----------------------------	----	--



E00887-10

- Check chain sliding piece for wear.
  - » If the lower edge of the chain pins is in line with or below the chain sliding piece:
    - Change the chain sliding piece. 🛠️
- Check that the chain sliding piece is firmly seated.
  - » If the chain sliding piece is loose:
    - Tighten screw on the chain sliding piece.

Guideline

Screw, chain sliding piece	M8	15 Nm (11.1 lbf ft)
----------------------------	----	---------------------

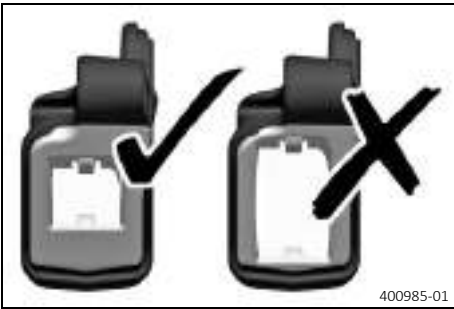

400985-01

- Check the chain guide for wear.



**Info**

Wear can be seen on the front of the chain guide.

- » If the light part of the chain guide is worn:
  - Change the chain guide. 🛠️



E00333-01

- Check that the chain guide is firmly seated.
  - » If the chain guide is loose:
    - Tighten the screws on the chain guide.

Guideline

Remaining screws, chassis	M6	10 Nm (7.4 lbf ft)
---------------------------	----	--------------------

**Finishing work**

- Remove the motorcycle from the lift stand. (📖 p. 52)



## 12.36 Checking the frame



- Check the frame for damage, cracks, and deformation.
  - » If the frame shows signs of damage, cracks, or deformation:
    - Change the frame.

Guideline

Repairs on the frame are not permitted.

## 12.37 Checking the link fork



- Check the link fork for damage, cracks, and deformation.
  - » If the link fork shows signs of damage, cracks, or deformation:
    - Change the link fork.

Guideline

Repairs on the link fork are not permitted.

## 12.38 Checking the throttle cable routing

### Preparatory work

- Remove the seat. (p. 64)
- Remove the fuel tank. (p. 70)

### Main work

- Check the throttle cable routing.

Both throttle cables must be routed, side by side, on the back of the handlebars, above the fuel tank bracket on the right of the frame to the throttle valve body. Both throttle cables must be secured behind the rubber strap of the fuel tank support.

- » If the throttle cable is not routed as specified:
  - Correct the throttle cable routing.



### Finishing work

- Install the fuel tank. (p. 71)
- Mount the seat. (p. 65)



**12.39 Checking the rubber grip**

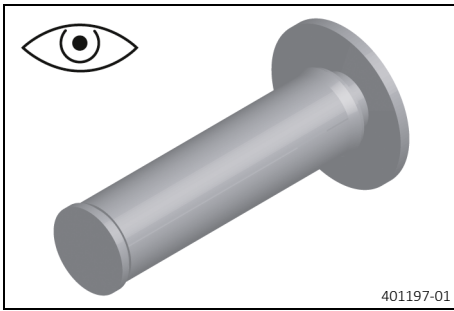

- Check the rubber grips on the handlebar for damage, wear, and looseness.

**i Info**  
 The rubber grips are vulcanized onto a sleeve on the left and onto the handle tube of the throttle grip on the right. The left sleeve is clamped onto the handlebar. The rubber grip can only be replaced with the sleeve or the throttle tube.

- » If a rubber grip is damaged or worn:
  - Change the rubber grip.

- Check that screw ① is firmly seated.

Guideline

Screw, fixed grip	M4	5 Nm (3.7 lbf ft) <b>Loctite® 243™</b>
-------------------	----	---

Diamond ② must be positioned visibly as shown in the figure.

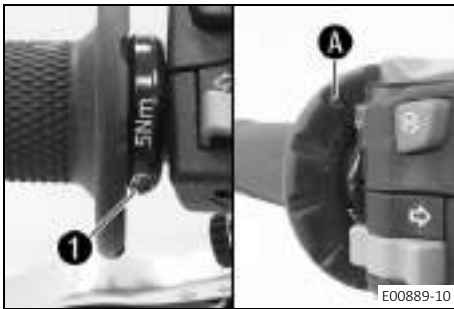

**12.40 Adjusting the basic position of the clutch lever**



- Adjust the basic position of the clutch lever to your hand size by turning adjusting screw ①.

**i Info**  
 Turn the adjusting screw counterclockwise to decrease the distance between the clutch lever and the handlebar. Turn the adjusting screw clockwise to increase the distance between the clutch lever and the handlebar. The range of adjustment is limited. Turn the adjusting screw by hand only, and do not apply any force. Do not make any adjustments while riding.

**12.41 Checking/correcting the fluid level of the hydraulic clutch**

**Warning**

**Skin irritation** Brake fluid causes skin irritation.

- Keep brake fluid out of the reach of children.
- Wear suitable protective clothing and safety glasses.
- Do not allow brake fluid to come into contact with the skin, the eyes or clothing.
- Consult a doctor immediately if brake fluid has been swallowed.
- Rinse the affected area with plenty of water in the event of contact with the skin.
- Rinse eyes thoroughly with water immediately and consult a doctor if brake fluid comes into contact with the eyes.
- If brake fluid spills on to your clothing, change the clothing.



**Note**

**Environmental hazard** Hazardous substances cause environmental damage.

- Dispose of oils, grease, filters, fuel, cleaning agents, brake fluid, etc., correctly and in compliance with the applicable regulations.



**Info**

The fluid level rises with increasing wear of the clutch facing discs.

Never use DOT 5 brake fluid. It is silicone-based and purple in color. Oil seals and clutch lines are not designed for DOT 5 brake fluid.

Avoid contact between brake fluid and painted parts. Brake fluid attacks paint.

Only use clean brake fluid from a sealed container.



- Move the clutch fluid reservoir mounted on the handlebar to a horizontal position.
- Remove screws **1**.
- Remove cover **2** with membrane **3**.
- Check the fluid level.

Fluid level below container rim	4 mm (0.16 in)
---------------------------------	----------------

» If the level of the fluid does not meet specifications:

- Correct the fluid level of the hydraulic clutch.

Brake fluid DOT 4 / DOT 5.1 (📖 p. 149)
--

- Position the cover with the membrane. Mount and tighten the screws.



**Info**

Clean up overflowed or spilled brake fluid immediately with water.

## 12.42 Changing the hydraulic clutch fluid 🛠️



**Warning**

**Skin irritation** Brake fluid causes skin irritation.

- Keep brake fluid out of the reach of children.
- Wear suitable protective clothing and safety glasses.
- Do not allow brake fluid to come into contact with the skin, the eyes or clothing.
- Consult a doctor immediately if brake fluid has been swallowed.
- Rinse the affected area with plenty of water in the event of contact with the skin.
- Rinse eyes thoroughly with water immediately and consult a doctor if brake fluid comes into contact with the eyes.
- If brake fluid spills on to your clothing, change the clothing.



**Note**

**Environmental hazard** Hazardous substances cause environmental damage.

- Dispose of oils, grease, filters, fuel, cleaning agents, brake fluid, etc., correctly and in compliance with the applicable regulations.

**i Info**

Never use DOT 5 brake fluid. It is silicone-based and purple in color. Oil seals and clutch lines are not designed for DOT 5 brake fluid.  
 Avoid contact between brake fluid and painted parts. Brake fluid attacks paint.  
 Only use clean brake fluid from a sealed container.



- Move the clutch fluid reservoir mounted on the handlebar to a horizontal position.
- Remove screws **1**.
- Take off cover **2** with membrane **3**.



- Fill bleeding syringe **4** with the appropriate hydraulic fluid.

Syringe (50329050000)
Brake fluid DOT 4 / DOT 5.1 (📖 p. 149)

- On the clutch slave cylinder, remove bleeder protection cap, release the bleeder screw **5** and mount bleeding syringe **4**.



- Now press the fluid into the system until it emerges from the hole **6** of the master cylinder without bubbles.
- Now and then, extract fluid from the master cylinder reservoir to prevent overflow.
- Remove the bleeding syringe. Tighten the bleeder screw. Mount protection cap.
- Correct the fluid level of the hydraulic clutch.

Guideline

Fluid level below container rim	4 mm (0.16 in)
---------------------------------	----------------

- Position cover with membrane. Mount and tighten screws.

**i Info**

Clean up overflowed or spilled brake fluid immediately with water.

## 13.1 Checking the free travel of the hand brake lever



### Warning

**Danger of accidents** The brake system fails in the event of overheating.

If there is no free travel on the hand brake lever, pressure builds up on the front brake circuit.

- Set the free travel on the hand brake lever in accordance with the specification.

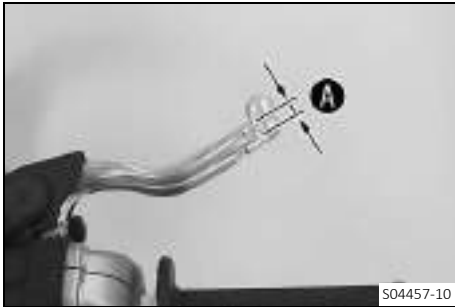

- Push the hand brake lever forward and check free travel **A**.

Free travel of hand brake lever	$\geq 3 \text{ mm } (\geq 0.12 \text{ in})$
---------------------------------	---

» If the free travel does not match the specification:

### (EC 300 US)

- Adjust the basic position of the hand brake lever. (🔧 p. 82)

## 13.2 Adjusting the basic position of the hand brake lever (EC 300 US)

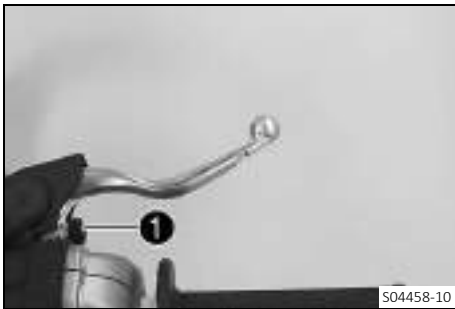

- Check the free travel of the hand brake lever. (🔧 p. 82)
- Adjust the basic position of the hand brake lever to your hand size by turning adjusting screw **1**.



### Info

Turn the adjusting screw clockwise to increase the distance between the hand brake lever and the handlebar. Turn the adjusting screw counterclockwise to decrease the distance between the hand brake lever and the handlebar. The range of adjustment is limited. Turn the adjusting screw by hand only, and do not apply any force. Do not make any adjustments while riding.

## 13.3 Checking the brake discs



### Warning

**Danger of accidents** Worn-out brake discs reduce the braking effect.

- Make sure that worn-out brake discs are replaced immediately. (Your authorized GASGAS Motorcycles workshop will be glad to help.)

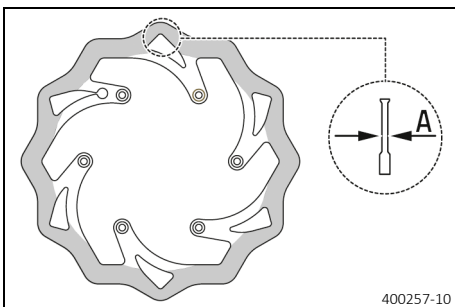

- Check the front and rear brake disc thickness at multiple points for the dimension **A**.



### Info

Wear reduces the thickness of the brake disc around the contact surface of the brake linings.

Brake discs - wear limit	
front	2.5 mm (0.098 in)
rear	3.5 mm (0.138 in)

- » If the brake disc thickness is less than the specified value:
  - Change the front brake disc. 🛠️
  - Change the rear brake disc. 🛠️
- Check the front and rear brake discs for damage, cracking, and deformation.
  - » If the brake disc exhibits damage, cracking, or deformation:
    - Change the front brake disc. 🛠️
    - Change the rear brake disc. 🛠️



### 13.4 Checking the front brake fluid level



#### Warning

**Danger of accidents** An insufficient brake fluid level will cause the brake system to fail.

If the brake fluid level drops below the specified marking or the specified value, the brake system is leaking or the brake linings are worn down.

- Check the brake system and do not continue riding until the problem is eliminated. (Your authorized GAS-GAS Motorcycles workshop will be glad to help.)



#### Warning

**Danger of accidents** Old brake fluid reduces the braking effect.

- Make sure that brake fluid for the front and rear brake is changed in accordance with the service schedule. (Your authorized GASGAS Motorcycles workshop will be glad to help.)

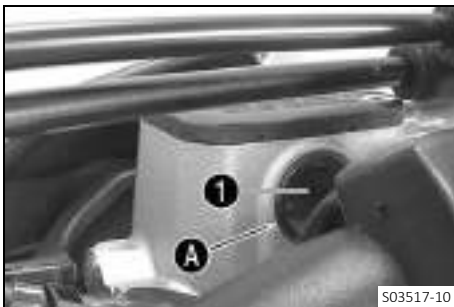

- Move the brake fluid reservoir mounted on the handlebar to a horizontal position.
- Check the brake fluid level in level viewer **1**.
  - » If an air bubble is visible in upper range of the level viewer **A**:
    - Add the front brake fluid. 🛠️ (📖 p. 83)



### 13.5 Adding front brake fluid 🛠️



#### Warning

**Danger of accidents** An insufficient brake fluid level will cause the brake system to fail.

If the brake fluid level drops below the specified marking or the specified value, the brake system is leaking or the brake linings are worn down.

- Check the brake system and do not continue riding until the problem is eliminated. (Your authorized GAS-GAS Motorcycles workshop will be glad to help.)



## Warning

**Skin irritation** Brake fluid causes skin irritation.

- Keep brake fluid out of the reach of children.
- Wear suitable protective clothing and safety glasses.
- Do not allow brake fluid to come into contact with the skin, the eyes or clothing.
- Consult a doctor immediately if brake fluid has been swallowed.
- Rinse the affected area with plenty of water in the event of contact with the skin.
- Rinse eyes thoroughly with water immediately and consult a doctor if brake fluid comes into contact with the eyes.
- If brake fluid spills on to your clothing, change the clothing.



## Warning

**Danger of accidents** Old brake fluid reduces the braking effect.

- Make sure that brake fluid for the front and rear brake is changed in accordance with the service schedule. (Your authorized GASGAS Motorcycles workshop will be glad to help.)



## Note

**Environmental hazard** Hazardous substances cause environmental damage.

- Dispose of oils, grease, filters, fuel, cleaning agents, brake fluid, etc., correctly and in compliance with the applicable regulations.



## Info

Never use DOT 5 brake fluid. It is silicone-based and purple in color. Oil seals and brake lines are not designed for DOT 5 brake fluid.

Avoid contact between brake fluid and painted parts. Brake fluid attacks paint.

Only use clean brake fluid from a sealed container.

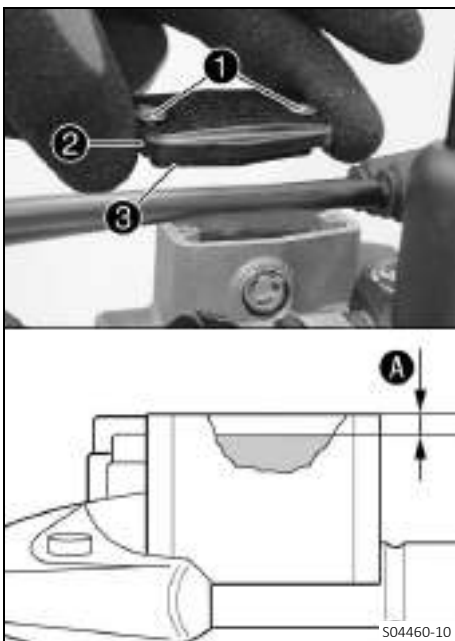

## Preparatory work

- Check the front brake linings. (📖 p. 85)

## Main work

- Move the brake fluid reservoir mounted on the handlebar to a horizontal position.
- Remove screws ①.
- Take off cover ② with membrane ③.
- Add brake fluid to level A.

Guideline

Level A (brake fluid level below reservoir rim)	5 mm (0.2 in)
---	---------------

Brake fluid DOT 4 / DOT 5.1 (📖 p. 149)
--

- Position the cover with the membrane. Mount and tighten the screws.



## Info

Immediately clean up any brake fluid that has overflowed or spilled using water.

### 13.6 Checking the front brake linings



#### Warning

**Danger of accidents** Worn-out brake linings reduce the braking effect.

- Ensure that worn-out brake linings are replaced immediately. (Your authorized GASGAS Motorcycles workshop will be glad to help.)

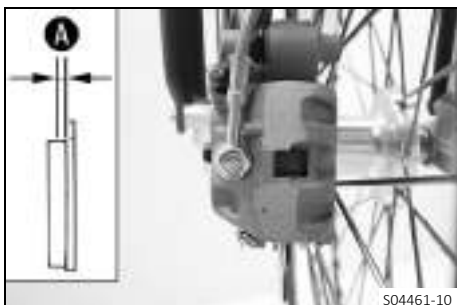

- Check the brake linings for minimum thickness **A**.

Minimum thickness <b>A</b>	$\geq 1 \text{ mm } (\geq 0.04 \text{ in})$
----------------------------	---

- » If the minimum thickness is less than specified:
  - Change the brake linings of the front brake. 🛠️ (p. 85)
- Check the brake linings for damage and cracking.
  - » If damage or wear is encountered:
    - Change the brake linings of the front brake. 🛠️ (p. 85)

### 13.7 Changing the brake linings of the front brake 🛠️



#### Warning

**Danger of accidents** Incorrect servicing will cause the brake system to fail.

- Ensure that service work and repairs are performed professionally. (Your authorized GASGAS Motorcycles workshop will be glad to help.)



#### Warning

**Skin irritation** Brake fluid causes skin irritation.

- Keep brake fluid out of the reach of children.
- Wear suitable protective clothing and safety glasses.
- Do not allow brake fluid to come into contact with the skin, the eyes or clothing.
- Consult a doctor immediately if brake fluid has been swallowed.
- Rinse the affected area with plenty of water in the event of contact with the skin.
- Rinse eyes thoroughly with water immediately and consult a doctor if brake fluid comes into contact with the eyes.
- If brake fluid spills on to your clothing, change the clothing.



#### Warning

**Danger of accidents** Old brake fluid reduces the braking effect.

- Make sure that brake fluid for the front and rear brake is changed in accordance with the service schedule. (Your authorized GASGAS Motorcycles workshop will be glad to help.)



#### Warning

**Danger of accidents** Oil or grease on the brake discs reduces the braking effect.

- Always keep the brake discs free of oil and grease.
- Clean the brake discs with brake cleaner when necessary.



## Warning

**Danger of accidents** Brake linings which have not been approved alter the braking efficiency.

Not all brake linings are tested and approved for GASGAS motorcycles. The structure and friction coefficient of the brake linings, and thus their brake power, may vary greatly from that of original brake linings. If brake linings are used that differ from the original equipment, compliance with the original homologation is not guaranteed. In this case, the vehicle no longer corresponds to its condition at delivery and the manufacturer warranty shall be void.

- Only use brake linings approved and recommended by GASGAS Motorcycles.



## Note

**Environmental hazard** Hazardous substances cause environmental damage.

- Dispose of oils, grease, filters, fuel, cleaning agents, brake fluid, etc., correctly and in compliance with the applicable regulations.



## Info

Never use DOT 5 brake fluid. It is silicone-based and purple in color. Oil seals and brake lines are not designed for DOT 5 brake fluid.

Avoid contact between brake fluid and painted parts. Brake fluid attacks paint.

Only use clean brake fluid from a sealed container.

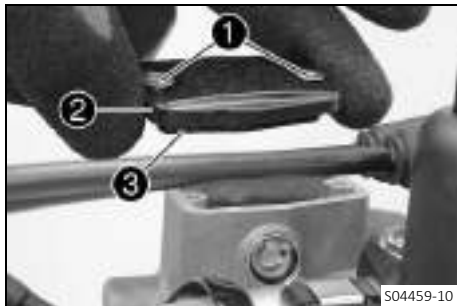

S04459-10

- Move the brake fluid reservoir mounted on the handlebar to a horizontal position.
- Remove screws **1**.
- Take off cover **2** with membrane **3**.
- Manually press the brake caliper toward the brake disc to push back the brake pistons. Ensure that brake fluid does not flow out of the brake fluid reservoir, extract some if necessary.



## Info

Make sure that you do not press the brake caliper against the spokes when pushing back the brake pistons.

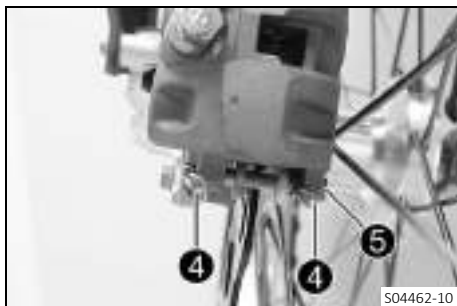

S04462-10

- Remove cotter pin **4**, pull out pin **5**, and remove the brake linings.
- Clean the brake caliper and the brake caliper bracket.



S04465-10

- Check that spring plate **6** in the brake caliper and sliding plate **7** in the brake caliper bracket are seated correctly.





- Insert the new brake linings, insert the pin, and mount the cotter pins.

**i Info**  
Always change the brake linings in pairs.

- Operate the hand brake lever repeatedly until the brake linings are in contact with the brake disc and there is a pressure point.

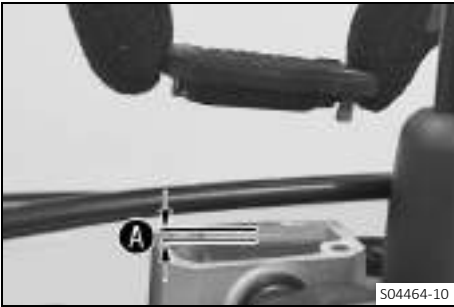

- Correct the brake fluid level to level **A**.

Guideline

Level <b>A</b> (brake fluid level below reservoir rim)	5 mm (0.2 in)
--	---------------

Brake fluid DOT 4 / DOT 5.1 (📖 p. 149)

- Position the cover with the membrane. Mount and tighten the screws.

**i Info**  
Use water to immediately clean up any brake fluid that has overflowed or spilled.

### 13.8 Checking the free travel of foot brake lever

**Warning**  
**Danger of accidents** The brake system fails in the event of overheating.  
If there is no free travel on the foot brake lever, pressure builds up in the brake system on the rear brake.

- Set the free travel on the foot brake lever in accordance with the specification.

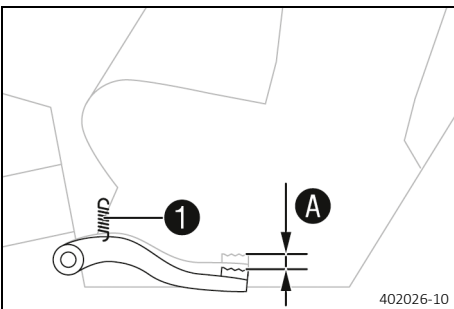

- Disconnect spring **1**.
- Move the foot brake lever back and forth between the end stop and the contact to the foot brake cylinder piston and check free travel **A**.

Guideline

Free travel at foot brake lever	3 ... 5 mm (0.12 ... 0.2 in)
---------------------------------	------------------------------

- » If the free travel does not meet specifications:
  - Adjust the basic position of the foot brake lever. 🛠️ (📖 p. 88)

- Reconnect spring **1**.

## 13.9 Adjusting the basic position of the foot brake lever ↩



### Warning

**Danger of accidents** The brake system fails in the event of overheating.

If there is no free travel on the foot brake lever, pressure builds up in the brake system on the rear brake.

- Set the free travel on the foot brake lever in accordance with the specification.

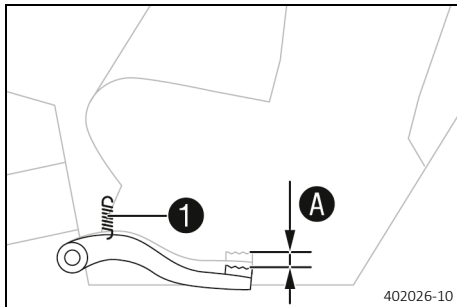

- Detach spring ①.

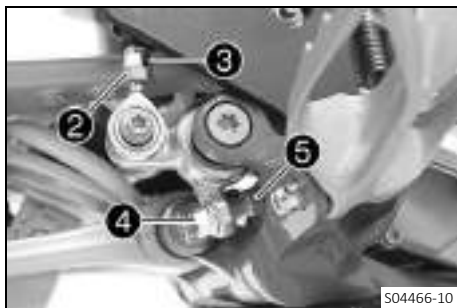

- Loosen nut ② and, with push rod ③, turn it back until you have maximum free travel.
- To adjust the basic position of the foot brake lever to individual requirements, loosen nut ④ and turn screw ⑤ accordingly.



### Info

The range of adjustment is limited.

- Turn push rod ③ accordingly until you have free travel A. If necessary, adjust the basic position of the foot brake lever.

Guideline

Free travel at foot brake lever	3 ... 5 mm (0.12 ... 0.2 in)
---------------------------------	------------------------------

- Hold screw ⑤ and tighten nut ④.

Guideline

Nut, foot brake lever stop	M8	20 Nm (14.8 lbf ft)
----------------------------	----	---------------------

- Hold push rod ③ and tighten nut ②.

Guideline

Remaining nuts, chassis	M6	10 Nm (7.4 lbf ft)
-------------------------	----	--------------------

- Attach spring ①.

## 13.10 Checking the rear brake fluid level



### Warning

**Danger of accidents** An insufficient brake fluid level will cause the brake system to fail.

If the brake fluid level drops below the specified marking or the specified value, the brake system is leaking or the brake linings are worn down.

- Check the brake system and do not continue riding until the problem is eliminated. (Your authorized GAS-GAS Motorcycles workshop will be glad to help.)

**Warning****Danger of accidents** Old brake fluid reduces the braking effect.

- Make sure that brake fluid for the front and rear brake is changed in accordance with the service schedule. (Your authorized GASGAS Motorcycles workshop will be glad to help.)

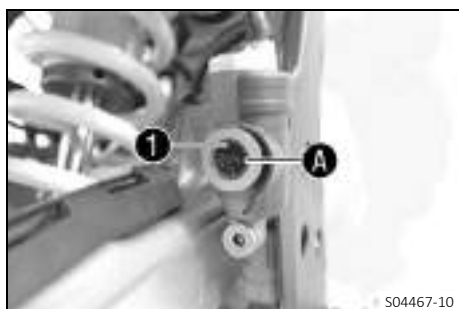

- Stand the vehicle upright.
- Check the brake fluid level in the viewer **1**.
  - » If the fluid has dropped below marking **A** in the level viewer:
    - Add rear brake fluid. (p. 89)

**13.11 Adding rear brake fluid** **Warning****Danger of accidents** An insufficient brake fluid level will cause the brake system to fail.

If the brake fluid level drops below the specified marking or the specified value, the brake system is leaking or the brake linings are worn down.

- Check the brake system and do not continue riding until the problem is eliminated. (Your authorized GASGAS Motorcycles workshop will be glad to help.)

**Warning****Skin irritation** Brake fluid causes skin irritation.

- Keep brake fluid out of the reach of children.
- Wear suitable protective clothing and safety glasses.
- Do not allow brake fluid to come into contact with the skin, the eyes or clothing.
- Consult a doctor immediately if brake fluid has been swallowed.
- Rinse the affected area with plenty of water in the event of contact with the skin.
- Rinse eyes thoroughly with water immediately and consult a doctor if brake fluid comes into contact with the eyes.
- If brake fluid spills on to your clothing, change the clothing.

**Warning****Danger of accidents** Old brake fluid reduces the braking effect.

- Make sure that brake fluid for the front and rear brake is changed in accordance with the service schedule. (Your authorized GASGAS Motorcycles workshop will be glad to help.)

**Note****Environmental hazard** Hazardous substances cause environmental damage.

- Dispose of oils, grease, filters, fuel, cleaning agents, brake fluid, etc., correctly and in compliance with the applicable regulations.

**Info**

Never use DOT 5 brake fluid. It is silicone-based and purple in color. Oil seals and brake lines are not designed for DOT 5 brake fluid.

Avoid contact between brake fluid and painted parts. Brake fluid attacks paint.

Only use clean brake fluid from a sealed container.

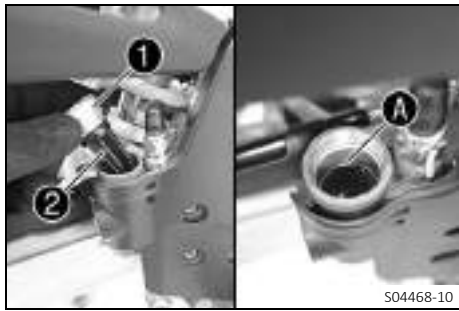

### Preparatory work

- Check the brake linings of the rear brake. (📖 p. 90)

### Main work

- Stand the vehicle upright.
- Remove screw cap ① with membrane ② and the O-ring.
- Add brake fluid to level A.

Brake fluid DOT 4 / DOT 5.1 (📖 p. 149)
--

- Mount and tighten the screw cap with the membrane and O-ring.

### Info

Clean up overflowed or spilled brake fluid immediately with water.

## 13.12 Checking the brake linings of the rear brake

### Warning

**Danger of accidents** Worn-out brake linings reduce the braking effect.

- Ensure that worn-out brake linings are replaced immediately. (Your authorized GASGAS Motorcycles workshop will be glad to help.)



- Check the brake linings for minimum thickness A.

Minimum thickness A	$\geq 1 \text{ mm } (\geq 0.04 \text{ in})$
---------------------	---

- » If the minimum thickness is less than specified:
  - Change the rear brake linings. (📖 p. 90)
- Check the brake linings for damage and cracking.
  - » If damage or wear is encountered:
    - Change the rear brake linings. (📖 p. 90)

## 13.13 Changing the rear brake linings 🛠️

### Warning

**Danger of accidents** Incorrect servicing will cause the brake system to fail.

- Ensure that service work and repairs are performed professionally. (Your authorized GASGAS Motorcycles workshop will be glad to help.)

### Warning

**Skin irritation** Brake fluid causes skin irritation.

- Keep brake fluid out of the reach of children.
- Wear suitable protective clothing and safety glasses.
- Do not allow brake fluid to come into contact with the skin, the eyes or clothing.
- Consult a doctor immediately if brake fluid has been swallowed.
- Rinse the affected area with plenty of water in the event of contact with the skin.
- Rinse eyes thoroughly with water immediately and consult a doctor if brake fluid comes into contact with the eyes.
- If brake fluid spills on to your clothing, change the clothing.

**Warning**

**Danger of accidents** Old brake fluid reduces the braking effect.

- Make sure that brake fluid for the front and rear brake is changed in accordance with the service schedule. (Your authorized GASGAS Motorcycles workshop will be glad to help.)

**Warning**

**Danger of accidents** Brake linings which have not been approved alter the braking efficiency.

Not all brake linings are tested and approved for GASGAS motorcycles. The structure and friction coefficient of the brake linings, and thus their brake power, may vary greatly from that of original brake linings. If brake linings are used that differ from the original equipment, compliance with the original homologation is not guaranteed. In this case, the vehicle no longer corresponds to its condition at delivery and the manufacturer warranty shall be void.

- Only use brake linings approved and recommended by GASGAS Motorcycles.

**Note**

**Environmental hazard** Hazardous substances cause environmental damage.

- Dispose of oils, grease, filters, fuel, cleaning agents, brake fluid, etc., correctly and in compliance with the applicable regulations.

**Info**

Never use DOT 5 brake fluid. It is silicone-based and purple in color. Oil seals and brake lines are not designed for DOT 5 brake fluid.

Avoid contact between brake fluid and painted parts. Brake fluid attacks paint.

Only use clean brake fluid from a sealed container.



- Position the vehicle upright.
- Remove screw cap ① with membrane ② and the O-ring.
- Press the brake piston back into the basic position and ensure that brake fluid does not flow out of the brake fluid reservoir, extracting some if necessary.

**Info**

Make sure that you do not press the brake caliper against the spokes when pushing back the brake piston.

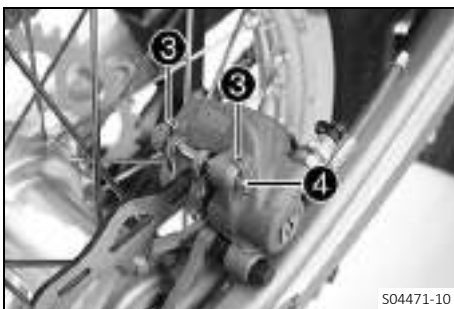

- Remove cotter pin ③, pull out pin ④, and remove the brake linings.
- Clean the brake caliper and the brake caliper bracket.

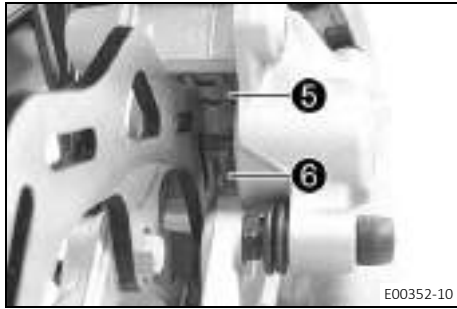

- Check that spring plate ⑤ in the brake caliper and sliding plate ⑥ in the brake caliper bracket are seated correctly.



- Insert the new brake linings, insert the pin, and mount the cotter pins.



**Info**

Always change the brake linings in pairs.

- Operate the foot brake lever repeatedly until the brake linings are in contact with the brake disc and there is a pressure point.



- Add brake fluid to level A.

Brake fluid DOT 4 / DOT 5.1 (📖 p. 149)

- Mount screw cap ① with membrane ② and O-ring.



**Info**

Use water to immediately clean up any brake fluid that has overflowed or spilled.

14.1 Removing the front wheel

**Preparatory work**

- Raise the motorcycle with a lift stand. (📖 p. 52)

**Main work**

- Manually press the brake caliper toward the brake disc to push back the brake pistons.

**i Info**  
Make sure that you do not press the brake caliper against the spokes when pushing back the brake pistons.

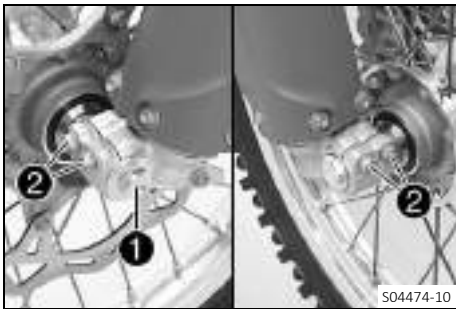

- Loosen screw ① by several rotations.
- Loosen screws ②.
- Press on screw ① to push the wheel spindle out of the axle clamp.
- Remove screw ①.

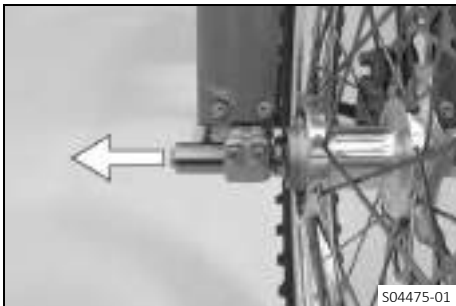

**! Warning**  
**Danger of accidents** Damaged brake discs reduce the braking effect.  
- Always lay the wheel down in such a way that the brake disc is not damaged.

- Hold the front wheel and remove the wheel spindle. Take the front wheel out of the fork.

**i Info**  
Do not actuate the hand brake lever when the front wheel is removed.

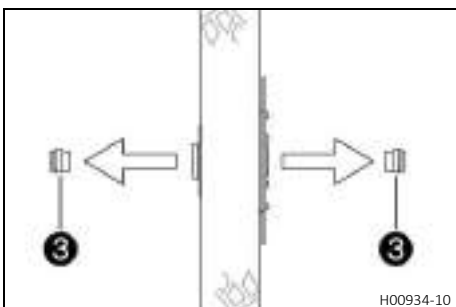

- Remove spacers ③.



## 14.2 Installing the front wheel



### Warning

**Danger of accidents** Oil or grease on the brake discs reduces the braking effect.

- Always keep the brake discs free of oil and grease.
- Clean the brake discs with brake cleaner when necessary.

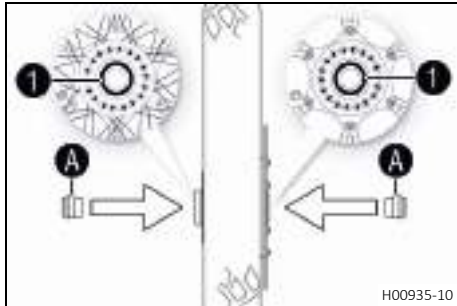

- Check the wheel bearing for damage and wear.
  - » If the wheel bearing is damaged or worn:
    - Change front wheel bearing.
- Clean and grease shaft seal rings 1 and contact surfaces A of the spacers.

Long-life grease (p. 151)
---------------------------

- Insert the spacers.
- Clean and grease the wheel spindle.

Long-life grease (p. 151)
---------------------------

- Jack up the front wheel into the fork, position it, and insert the wheel spindle.

✓ The brake linings are correctly positioned.

- Mount and tighten screw 2.

Guideline

Screw, front wheel spindle	M20x1.5	35 Nm (25.8 lbf ft)
----------------------------	---------	---------------------

- Operate the hand brake lever several times until the brake linings are seated correctly against the brake disc.
- Remove the motorcycle from the lift stand. (p. 52)
- Operate the front brake and compress the fork a few times firmly.

✓ The fork legs straighten.

- Tighten screws 3.

Guideline

Screw, fork stub	M8	15 Nm (11.1 lbf ft)
------------------	----	---------------------

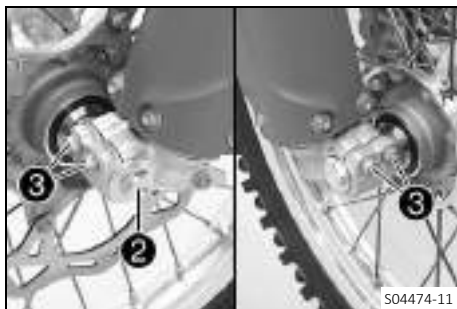

## 14.3 Removing the rear wheel

### Preparatory work

- Raise the motorcycle with a lift stand. (p. 52)



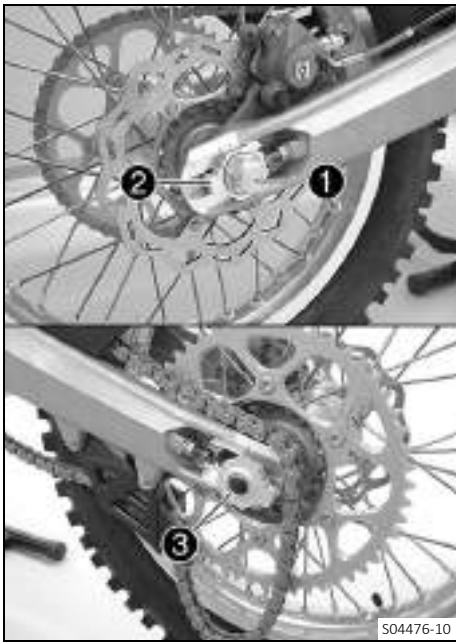

**Main work**

- Manually press the brake caliper toward the brake disc to push back the brake piston.



**Info**

Make sure that you do not press the brake caliper against the spokes when pushing back the brake piston.

- Remove nut 1.
- Take off chain adjuster 2. Pull out wheel spindle 3 far enough to allow the rear wheel to be pushed forward.
- Push the rear wheel forward as far as possible. Remove the chain from the rear sprocket.



**Info**

Cover the components to protect them against damage.



**Warning**

**Danger of accidents** Damaged brake discs reduce the braking effect.

- Always lay the wheel down in such a way that the brake disc is not damaged.

- Hold the rear wheel and remove the wheel spindle. Take the rear wheel out of the link fork.



**Info**

Do not operate the foot brake lever when the rear wheel is removed.

- Remove spacers 4.

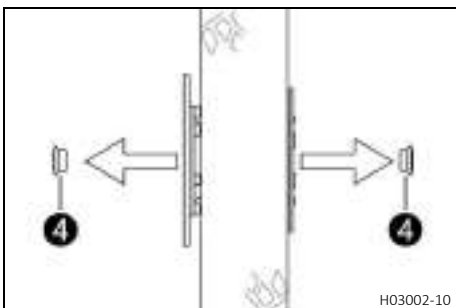

**14.4 Installing the rear wheel**



**Warning**

**Danger of accidents** Oil or grease on the brake discs reduces the braking effect.

- Always keep the brake discs free of oil and grease.
- Clean the brake discs with brake cleaner when necessary.

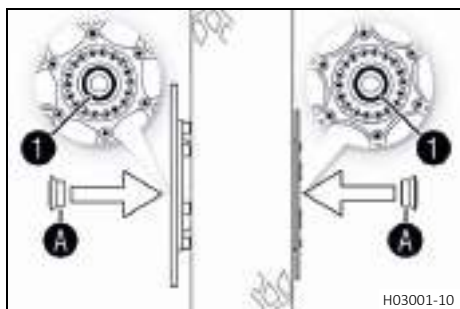

## Main work

- Check the wheel bearing for damage and wear.
  - » If the wheel bearing is damaged or worn:
    - Change the rear wheel bearing. 🛠️
- Clean and grease shaft seal rings ① and contact surfaces A of the spacers.

Long-life grease (📖 p. 151)

- Insert the spacers.
- Clean and grease the wheel spindle.

Long-life grease (📖 p. 151)



- Position rear wheel and insert wheel spindle ②.
- Mount the chain.
  - ✓ The brake linings are correctly positioned.

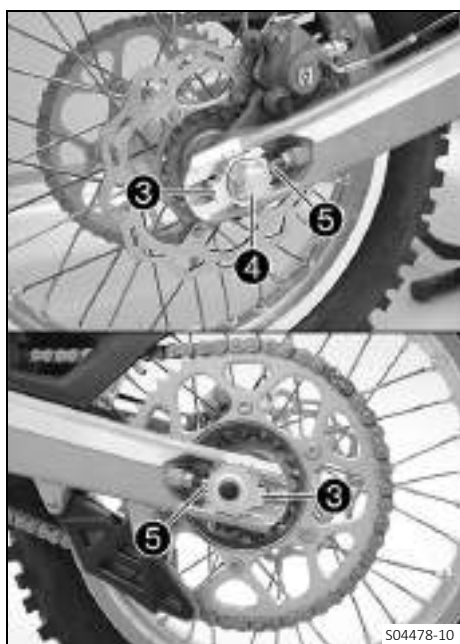

- Position chain adjuster ③. Mount nut ④, but do not tighten it yet.
- Make sure that chain adjusters ③ are fitted correctly on adjusting screws ⑤.
- Check the chain tension. (📖 p. 74)
- Tighten nut ④.

## Guideline

Nut, rear wheel spindle	M20x1.5	80 Nm (59 lbf ft)
-------------------------	---------	-------------------

## Info

The wide adjustment range of the chain adjusters (32 mm (1.26 in)) enables different secondary ratios with the same chain length.

Chain adjusters ③ can be turned by 180°.

- Operate the foot brake lever repeatedly until the brake linings are in contact with the brake disc and there is a pressure point.

## Finishing work

- Remove the motorcycle from the lift stand. (📖 p. 52)

**14.5 Checking the tire condition**

**i Info**  
 Only mount tires approved and/or recommended by GASGAS Motorcycles.  
 Other tires could have a negative effect on handling characteristics.  
 The type, condition, and pressure of the tires all have a major impact on the handling characteristic of the motorcycle.  
 Worn tires have a negative effect on handling characteristics, especially on wet surfaces.

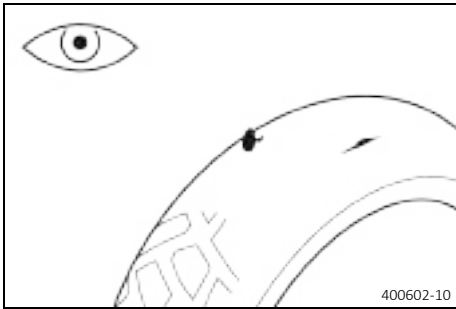

- Check the front and rear tires for cuts, embedded objects, and other damage.
  - » If the tires have cuts, run-in objects, or other damage:
    - Change the tires. 🛠️
- Check tread depth.

**i Info**  
 Adhere to the legally required minimum tread depth.

Minimum tread depth	≥ 2 mm (≥ 0.08 in)
---------------------	--------------------

- » If the tread depth is less than the minimum tread depth:
  - Change the tires. 🛠️



- Check the tire age.

**i Info**  
 The tire date of manufacture is usually contained in the tire label and is indicated by the last four digits of the **DOT** number. The first two digits indicate the week of manufacture and the last two digits the year of manufacture.  
 GASGAS Motorcycles recommends that the tires be changed after five years at the latest, regardless of the actual wear.

- » If the tires are more than five years old:
  - Change the tires. 🛠️

**14.6 Checking tire pressure**

**i Info**  
 Low tire pressure leads to abnormal wear and overheating of the tire.  
 Correct tire pressure ensures optimal riding comfort and maximum tire service life.

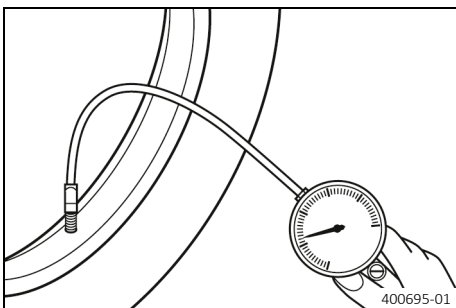

- Remove protection cap.
- Check tire pressure when the tires are cold.

Offroad tire pressure	
front	1.0 bar (15 psi)
rear	1.0 bar (15 psi)

- » If the tire pressure does not meet specifications:
  - Correct tire pressure.
- Mount the protection cap.

## 14.7 Checking spoke tension



### Warning

**Danger of accidents** Incorrectly tensioned spokes impair the handling characteristic and result in secondary damage.

The spokes break due to being overloaded if they are too tightly tensioned. If the tension in the spokes is too low, then lateral and radial run-out will form in the wheel. Other spokes will become looser as a result.

- Check spoke tension regularly, and in particular on a new vehicle. (Your authorized GASGAS Motorcycles workshop will be glad to help.)

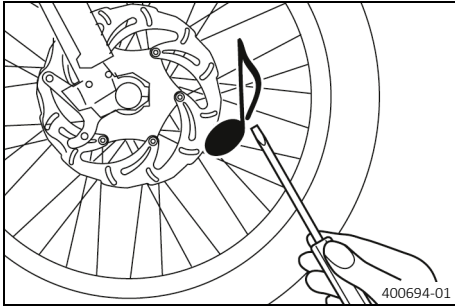

- Strike each spoke briefly using a screwdriver blade.



### Info

The frequency of the sound depends on the spoke length and spoke diameter.

If you hear different tone frequencies from different spokes of equal length and diameter, this is an indication of different spoke tensions.

You should hear a high note.

» If the spoke tension differs:

- Correct the spoke tension. 🛠️

- Check the spoke torque.

Guideline

Spoke nipple, front wheel	M4.5	6 Nm (4.4 lbf ft)
Spoke nipple, rear wheel	M4.5	6 Nm (4.4 lbf ft)

Torque wrench kit (58429094000)

## 15.1 Removing the 12-V battery



### Note

**Environmental hazard** 12 V batteries contain environmentally hazardous materials.

- Do not dispose of 12 V batteries as household waste.
- Dispose of 12 V batteries at a collection point for used batteries.



### Note

**Environmental hazard** Hazardous substances cause environmental damage.

- Dispose of oils, grease, filters, fuel, cleaning agents, brake fluid, etc., correctly and in compliance with the applicable regulations.

### Preparatory work

- Remove the seat. (📖 p. 64)

### Main work



### Warning

**Risk of injury** 12 V batteries contain harmful substances.

- Keep 12 V batteries out of the reach of children.
- Keep sparks and open flames away from 12 V batteries.
- Only charge 12 V batteries in well-ventilated rooms.
- Maintain a minimum clearance from inflammable materials when charging 12 V batteries.  
Minimum clearance 1 m (3 ft)
- Do not charge deeply discharged 12 V batteries if the charge is already below the minimum voltage.  
Minimum voltage before the start of the charge 9 V
- Dispose of 12 V batteries with less than the minimum voltage correctly.

- Disconnect negative cable ① from the 12-V battery.
- Pull back positive terminal cover ② and disconnect the positive cable from the 12-V battery.
- Pull EFI control unit ③ upward off rubber lugs ④ and hang to the side.



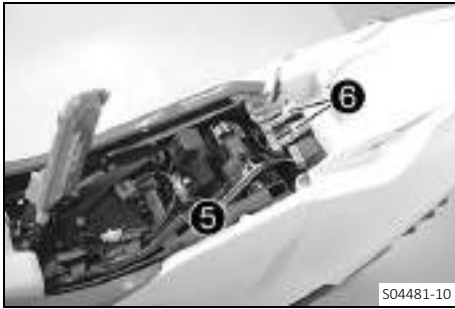

- Detach wiring harness **5**, pull off relays **6** and hang them to the side.



- Remove screw **7** and fold the battery compartment to the front.
- Lift out the 12-V battery.



## 15.2 Installing the 12-V battery



### Main work

- Insert the 12-V battery into the battery compartment with the terminals facing forward and secure with holding bracket **1**.

12-V battery (HJTZ5S-FP-C) (📖 p. 145)

- Mount and tighten screw **2**.

### Guideline

Remaining screws, chassis	M6	10 Nm (7.4 lbf ft)
---------------------------	----	--------------------

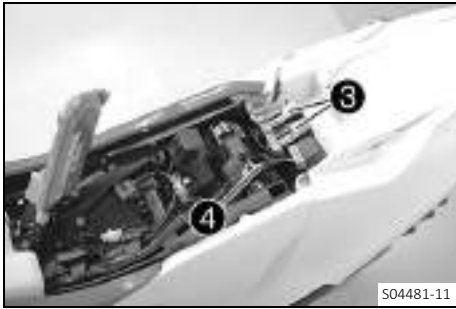

- Place relays **3** on the battery compartment and attach wiring harness **4**.

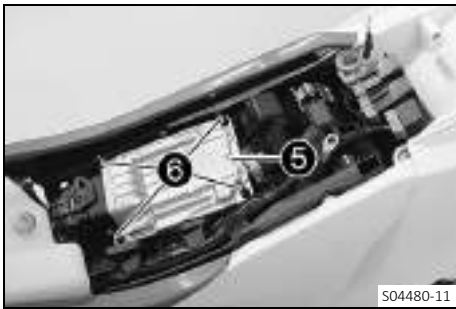

- Secure EFI control unit **5** with the rubber lugs **6**.

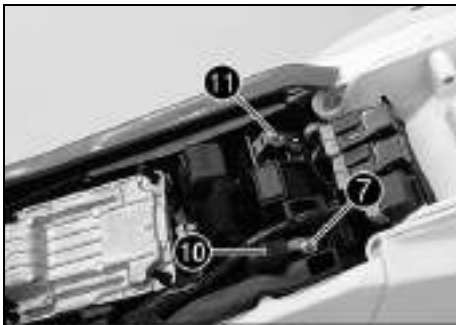

- Connect positive cable **7** to the 12-V battery.

Guideline

Screw, battery terminal	M5	2.5 Nm (1.84 lbf ft)
-------------------------	----	----------------------



**Info**

Contact disk **A** must be mounted under screw **8** and cable lug **9** with the claws toward the battery terminal.

- Slide positive terminal cover **10** over the positive terminal.
- Connect negative cable **11** to the 12-V battery.

Guideline

Screw, battery terminal	M5	2.5 Nm (1.84 lbf ft)
-------------------------	----	----------------------

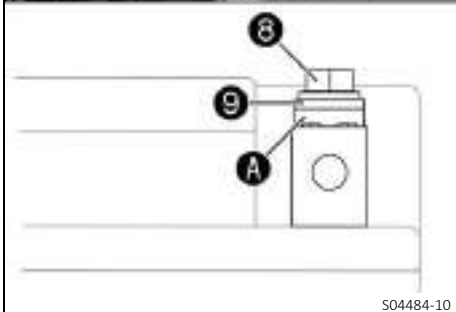

**Finishing work**

- Mount the seat. (🛠️ p. 65)



## 15.3 Charging the 12-V battery ↴



### Warning

**Risk of injury** 12 V batteries contain harmful substances.

- Keep 12 V batteries out of the reach of children.
- Keep sparks and open flames away from 12 V batteries.
- Only charge 12 V batteries in well-ventilated rooms.
- Maintain a minimum clearance from inflammable materials when charging 12 V batteries.  
Minimum clearance 1 m (3 ft)
- Do not charge deeply discharged 12 V batteries if the charge is already below the minimum voltage.  
Minimum voltage before the start of the charge 9 V
- Dispose of 12 V batteries with less than the minimum voltage correctly.



### Note

**Environmental hazard** 12 V batteries contain environmentally hazardous materials.

- Do not dispose of 12 V batteries as household waste.
- Dispose of 12 V batteries at a collection point for used batteries.



### Note

**Environmental hazard** Hazardous substances cause environmental damage.

- Dispose of oils, grease, filters, fuel, cleaning agents, brake fluid, etc., correctly and in compliance with the applicable regulations.



### Info

Even when there is no load on the 12-V battery, it discharges steadily each day.

The charging level and the method of charging are very important for the service life of the 12-V battery.

Rapid recharging with a high charging current shortens the service life of the battery.

If the charging current or charging voltage are exceeded, the 12-V battery will be destroyed.

If the 12-V battery is depleted by repeated starting, the 12-V battery must be charged immediately.

If the 12-V battery is left in a discharged state for an extended period, it will become deeply discharged and suffer a loss of capacity, destroying the battery.

The 12-V battery is maintenance-free.



### Preparatory work

- Remove the seat. (📖 p. 64)
- Remove the 12-V battery. ↴ (📖 p. 99)

### Main work

- Check the battery voltage.
  - » Battery voltage: < 9 V
    - Do not charge the 12-V battery.
    - Replace the 12-V battery and dispose of the old 12-V battery properly.
  - » If the specifications have been met:
    - Battery voltage: ≥ 9 V
    - Charge the 12-V battery.



## Guideline

The charging current, charging voltage, and charging time must not be exceeded.	
Maximum charging voltage	14.4 V
Maximum charging current	3.0 A
Maximum charging time	24 h
Recharge the 12-V battery regularly when the motor-cycle is not being used	6 months

## Battery charger (79629974000)

This battery charger tests whether the 12-V battery retains its voltage. It is also impossible to overcharge the 12-V battery with this battery charger. The charging time may be longer at low temperatures.

This battery charger is only suitable for lithium iron phosphate batteries. Read the accompanying **GASGAS Technical Accessories** instructions.

**i Info**  
Never remove cover ①.

- Switch off the battery charger after charging and disconnect from the 12-V battery.

**Finishing work**

- Install the 12-V battery. (🔧📖 p. 100)
- Mount the seat. (📖 p. 65)



## 15.4 Changing main fuse

**Warning**

**Fire hazard** Incorrect fuses overload the electrical system.

- Only use fuses with the required ampere value.
- Do not bypass or repair fuses.

**Info**

The main fuse protects all electrical power consumers of the vehicle.

**Preparatory work**

- Remove the seat. (📖 p. 64)

**Main work**

- Pull EFI control unit ① upward off the rubber lugs ② and hang to the side.



S04485-10



- Pull starter relay **3** from the holder.

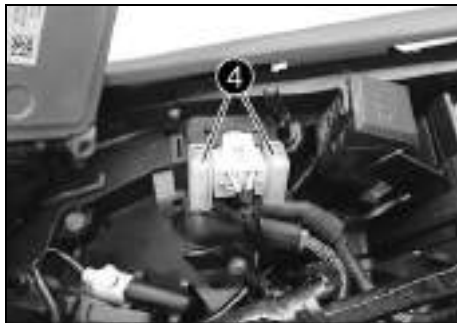

- Take off protection caps **4**.
- Remove faulty main fuse **5**.



### Info

A faulty fuse has a burned-out fuse wire **A**.  
A spare fuse **6** is located in the starter relay.

- Insert a new main fuse.

Fuse (58011109120) (📖 p. 145)

- Check that the electrical system is functioning properly.



### Tip

Insert a spare fuse so that it is available if needed.



- Attach the protection caps **4**.
- Mount starter relay **3** onto the holder and route the cable.



- Mount the EFI control unit **1** on the rubber lugs **2**.

### Finishing work

- Mount the seat. (📖 p. 65)

## 15.5 Changing the fuses of individual electrical power consumers

### Info

The fuse box containing the fuses of individual electrical power consumers is located under the seat.

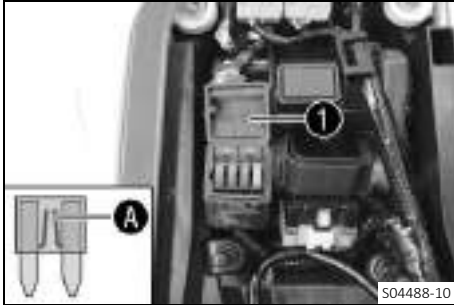

### Preparatory work

- Remove the seat. (📖 p. 64)

### Main work

- Open fuse box cover ①.
- Remove the faulty fuse.

#### Guideline

#### (All EU models)

Fuse <b>1</b> - 10 A - EFI control unit, lambda sensor, oil pump, combination instrument, electronic fuel injection, diagnostics connector
--

Fuse <b>2</b> - 10 A - horn, brake light, radiator fan (optional), turn signal (optional)
---

Fuse <b>3</b> - 10 A - high beam, low beam, position light, tail light, license plate lamp
--

Fuse <b>4</b> - 5 A - fuel pump
---------------------------------

#### (EC 300 US)

Fuse <b>1</b> - 10 A - EFI control unit, oil pump, combination instrument, electronic fuel injection, diagnostics connector
---

Fuse <b>2</b> - 10 A - radiator fan (optional)
--

Fuse <b>3</b> - 10 A - low beam, position light, tail light
---

Fuse <b>4</b> - 5 A - fuel pump
---------------------------------

Fuses <b>res</b> - 10 A - spare fuse
--------------------------------------

### Info

A faulty fuse has a burned-out fuse wire ①.



### Warning

**Fire hazard** Incorrect fuses overload the electrical system.

- Only use fuses with the required ampere value.
- Do not bypass or repair fuses.

- Insert the spare fuse with the correct rating.

Fuse (75011088010) (📖 p. 145)
-------------------------------

Fuse (75011088005) (📖 p. 145)
-------------------------------

### Tip

Put a spare fuse in the fuse box so that it is available if needed.

- Check the function of the electrical power consumer.
- Close the fuse box cover ①.

### Finishing work

- Mount the seat. (📖 p. 65)

## 15.6 Removing the headlight mask with the headlight

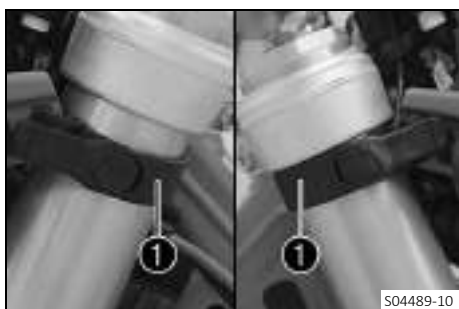

- Detach the brake line and wiring harness from the headlight mask.
- Loosen rubber strap **1**. Slide the headlight mask up and swing it forward.



### (All EU models)

- Detach plug-in connectors **2** and take off the headlight mask with the headlight.



### (EC 300 US)

- Disconnect plug-in connector **2** and take off the headlight mask together with the headlight.

## 15.7 Installing the headlight mask with the headlight



### Main work

#### (All EU models)

- Join plug-in connectors **1**.



### (EC 300 US)

- Join plug-in connector **1**.

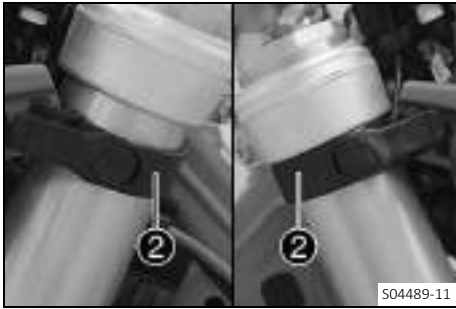

- Position the headlight mask and secure it with rubber straps ②.
  - ✓ The holding lugs engage in the fender.
- Position the brake line and wiring harness in the brake line guide.

#### Finishing work

- Check the headlight setting. (📖 p. 108)



## 15.8 Changing the headlight bulb

### Note

**Damage to reflector** Grease on the reflector reduces the light intensity.

Grease on the bulb will evaporate due to the heat and be deposited on the reflector.

- Clean and degrease the bulbs before mounting.
- Do not touch the bulbs with your bare hands.

### Preparatory work

- Remove the headlight mask with the headlight. (📖 p. 106)

### Main work

- Turn protection cap ① together with the underlying bulb socket counterclockwise all the way and remove it.
- Pull bulb socket ② of the position light out of the reflector.

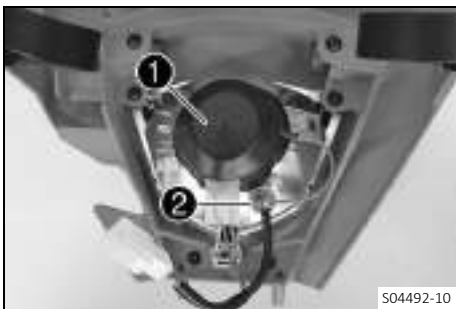

- Pull out headlight bulb ③.
- Insert the new headlight bulb.

Headlight (S2 / socket BA20d) (📖 p. 145)

- Insert the protection cap with the bulb socket into the reflector and turn it clockwise all the way.

### Info

Check the sealing lip ④ of the protection cap for correct seating.

- Insert the bulb socket of the position light into the reflector.

### Finishing work

- Install the headlight mask with the headlight. (📖 p. 106)
- Check the headlight setting. (📖 p. 108)



## 15.9 Changing the turn signal bulb (All EU models)

### Note

**Damage to reflector** Grease on the reflector reduces the light intensity.

Grease on the bulb will evaporate due to the heat and be deposited on the reflector.

- Clean and degrease the bulbs before mounting.
- Do not touch the bulbs with your bare hands.

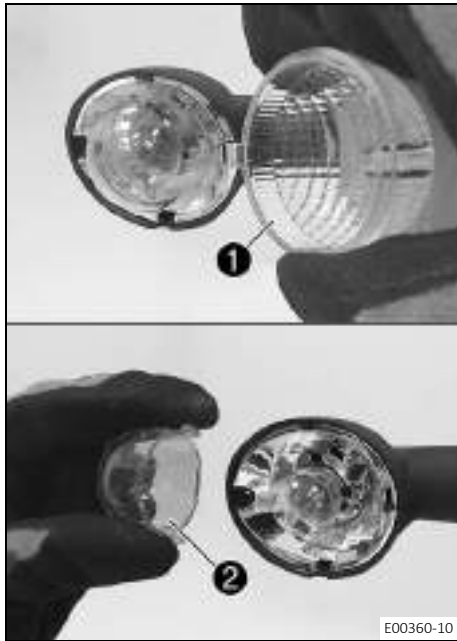

### Main work

- Remove the screw on the rear of the turn signal housing.
- Carefully remove turn signal glass ①.
- Lightly squeeze orange cap ② in the area of the holding lugs and take it off.
- Press the turn signal bulb lightly into the socket, turn it counter-clockwise by about 30°, and take it out of the socket.



### Info

Do not touch the reflector with your fingers and keep it free from grease.

- Press the new turn signal bulb carefully into the socket and turn it clockwise until it stops.

Turn signal (R10W / socket BA15s) (📖 p. 145)
--

- Mount the orange cap.
- Position the turn signal glass.
- Insert the screw and first turn counterclockwise until it engages in the thread with a small jerk. Tighten the screw lightly.

### Finishing work

- Check that the turn signal system is functioning properly.

## 15.10 Checking the headlight setting

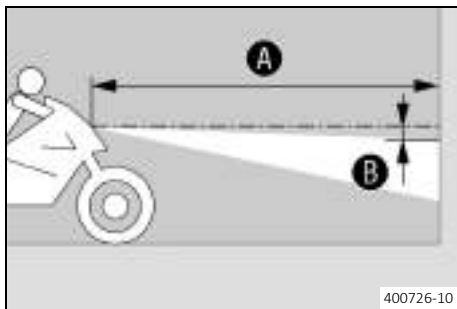

- Park the vehicle on a horizontal surface in front of a light-colored wall and make a mark at the height of the center of the low beam headlight.

- Make another mark at a distance ② under the first marking.

Guideline

Distance ②	5 cm (2 in)
------------	-------------

- Position the vehicle vertically at a distance ① away from the wall.

Guideline

Distance ①	5 m (16 ft)
------------	-------------

- The rider now sits down on the motorcycle.
- Switch on the low beam.
- Check the headlight setting.

The boundary between light and dark must be exactly on the lower mark for a motorcycle with rider.
--

- » If the boundary between light and dark does not meet specifications:

- Adjust headlight range. (📖 p. 109)



### 15.11 Adjusting the headlight range



#### Preparatory work

- Check the headlight setting. (📖 p. 108)
- Remove the headlight mask with the headlight. (📖 p. 106)

#### Main work

- Turn bolt ① clockwise.
  - ✓ The headlight range increases.
- Turn bolt ① counterclockwise.
  - ✓ The headlight range decreases.
- Adjust the headlight range by pivoting the headlight.

#### Guideline

The boundary between light and dark must be exactly on the lower mark for a motorcycle with rider (instructions on how to apply the mark: Checking the headlight setting).



#### Info

If you have a payload, you may have to correct the headlight range.

- Install the headlight mask with the headlight. (📖 p. 106)
- Check the headlight setting. (📖 p. 108)



### 15.12 Changing the combination instrument battery



#### Preparatory work

- Remove the headlight mask with the headlight. (📖 p. 106)

#### Main work

- Remove screws ①.
- Pull the combination instrument upward out of the holder.

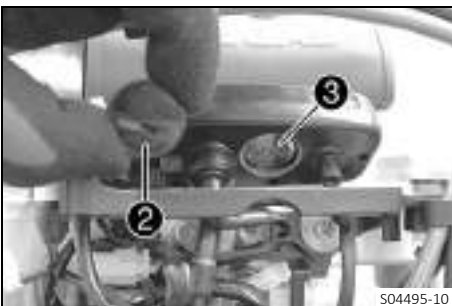

- Using a coin, turn protection cap ② all the way counterclockwise and take it off.
- Remove combination instrument battery ③.
- Insert the combination instrument battery with the label facing outward.

Combination instrument battery (CR 2032) (📖 p. 145)

- Check the O-ring of the protection cap for correct seating.

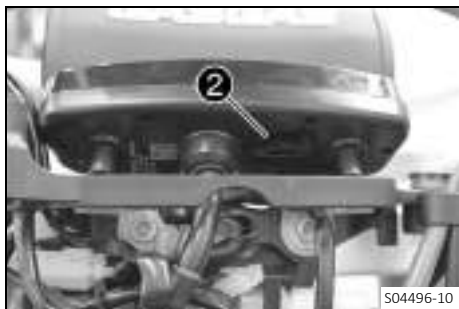

- Position protection cap ② and turn all the way clockwise using a coin.
- Press any button on the combination instrument.
  - ✓ The combination instrument is activated.
- Position the combination instrument in the holder.
- Mount and tighten the screws with washers.

### Finishing work

- Install the headlight mask with the headlight. (📖 p. 106)
- Check the headlight setting. (📖 p. 108)
- Set the kilometers or miles.
- Adjust combination instrument function.
- Set the clock.

### 15.13 Diagnostics connector

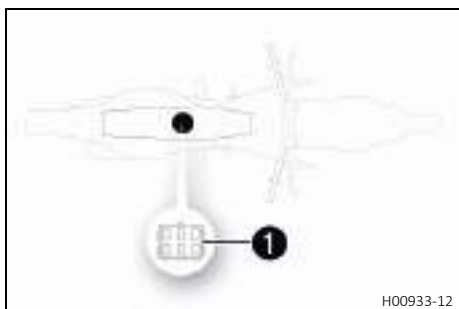

Diagnostics connector ① is located under the seat below the EFI control unit.



16.1 Cooling system

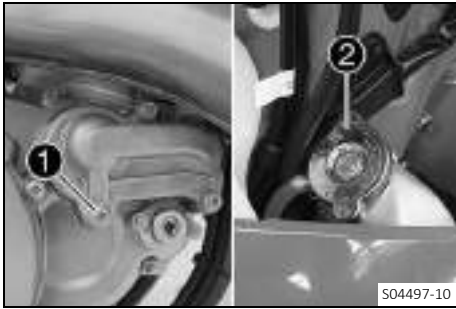

Water pump ① in the engine ensures forced circulation of the coolant. The pressure resulting from the warming of the cooling system is regulated by a valve in radiator cap ②. This ensures that operating the vehicle at the specified coolant temperature will not result in a risk of malfunctions.

120 °C (248 °F)
-----------------

Cooling is effected by the air stream. The lower the speed, the less the cooling effect. Dirty cooling fins also reduce the cooling effect.

16.2 Checking the antifreeze and coolant level



**Warning**

**Danger of scalding** During motorcycle operation, the coolant gets very hot and is under pressure.

- Do not open the radiator, the radiator hoses or other cooling system components if the engine or the cooling system are at operating temperature.
- Allow the cooling system and the engine to cool down before you open the radiator, the radiator hoses or other components of the cooling system.
- In the event of scalding, rinse the area affected immediately with lukewarm water.



**Warning**

**Danger of poisoning** Coolant is toxic and a health hazard.

- Keep coolant out of the reach of children.
- Do not allow coolant to come into contact with the skin, the eyes and clothing.
- Consult a doctor immediately if coolant is swallowed.
- Rinse the affected area immediately with plenty of water in the event of contact with the skin.
- Rinse eyes thoroughly with water and consult a doctor immediately if coolant gets into the eyes.
- Change clothing if coolant spills onto your clothing.

**Condition**

The engine is cold.

- Stand the motorcycle upright on a horizontal surface.
- Remove the radiator cap.
- Check the coolant antifreeze.

-25 ... -45 °C (-13 ... -49 °F)
---------------------------------

» If the antifreeze in the coolant does not match the specified value:

- Correct the coolant antifreeze.

- Check the coolant level in the radiator.

Coolant level ① above the radiator fins	10 mm (0.39 in)
---	-----------------

» If the coolant level does not match the specified value:

- Correct the coolant level.

Coolant (📖 p. 149)
--------------------

- Mount the radiator cap.

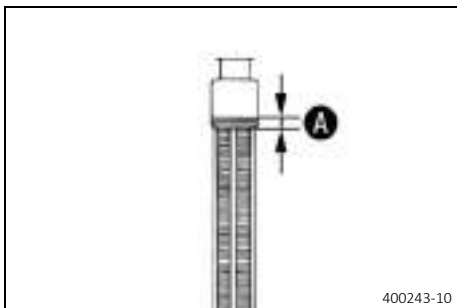

## 16.3 Checking the coolant level



### Warning

**Danger of scalding** During motorcycle operation, the coolant gets very hot and is under pressure.

- Do not open the radiator, the radiator hoses or other cooling system components if the engine or the cooling system are at operating temperature.
- Allow the cooling system and the engine to cool down before you open the radiator, the radiator hoses or other components of the cooling system.
- In the event of scalding, rinse the area affected immediately with lukewarm water.



### Warning

**Danger of poisoning** Coolant is toxic and a health hazard.

- Keep coolant out of the reach of children.
- Do not allow coolant to come into contact with the skin, the eyes and clothing.
- Consult a doctor immediately if coolant is swallowed.
- Rinse the affected area immediately with plenty of water in the event of contact with the skin.
- Rinse eyes thoroughly with water and consult a doctor immediately if coolant gets into the eyes.
- Change clothing if coolant spills onto your clothing.

### Condition

The engine is cold.

- Stand the motorcycle upright on a horizontal surface.
- Remove the radiator cap.
- Check the coolant level in the radiator.

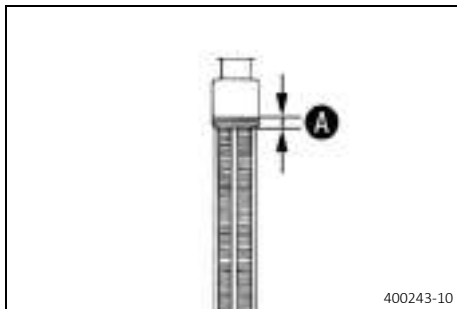

Coolant level <b>A</b> above the radiator fins	10 mm (0.39 in)
--	-----------------

- » If the coolant level does not match the specified value:
  - Correct the coolant level.

Coolant (📖 p. 149)
--------------------

- Mount the radiator cap.

## 16.4 Draining the coolant 🐉



### Warning

**Danger of scalding** During motorcycle operation, the coolant gets very hot and is under pressure.

- Do not open the radiator, the radiator hoses or other cooling system components if the engine or the cooling system are at operating temperature.
- Allow the cooling system and the engine to cool down before you open the radiator, the radiator hoses or other components of the cooling system.
- In the event of scalding, rinse the area affected immediately with lukewarm water.



**Warning**

**Danger of poisoning** Coolant is toxic and a health hazard.

- Keep coolant out of the reach of children.
- Do not allow coolant to come into contact with the skin, the eyes and clothing.
- Consult a doctor immediately if coolant is swallowed.
- Rinse the affected area immediately with plenty of water in the event of contact with the skin.
- Rinse eyes thoroughly with water and consult a doctor immediately if coolant gets into the eyes.
- Change clothing if coolant spills onto your clothing.

**Condition**

The engine is cold.

- Position the motorcycle upright.
- Place an appropriate container under the water pump cover.
- Remove screw ❶. Take off radiator cap ❷.
- Completely drain the coolant.
- Mount and tighten screw ❶ with a new seal ring.

Guideline

Screw, water pump cover	M6	10 Nm (7.4 lbf ft)
-------------------------	----	--------------------



**16.5 Refilling with coolant**



**Warning**

**Danger of poisoning** Coolant is toxic and a health hazard.

- Keep coolant out of the reach of children.
- Do not allow coolant to come into contact with the skin, the eyes and clothing.
- Consult a doctor immediately if coolant is swallowed.
- Rinse the affected area immediately with plenty of water in the event of contact with the skin.
- Rinse eyes thoroughly with water and consult a doctor immediately if coolant gets into the eyes.
- Change clothing if coolant spills onto your clothing.

**Main work**

- Make sure that screw ❶ is tightened.
- Position the motorcycle upright.



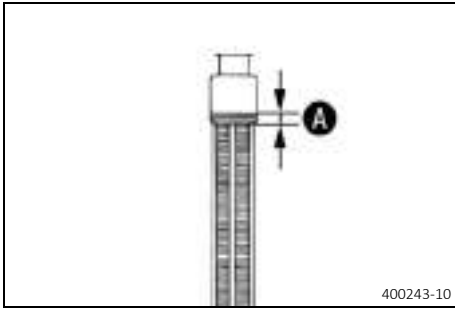

- Pour coolant in up to measurement **A** above the radiator fins.

Guideline

10 mm (0.39 in)
-----------------

Coolant	1.2 l (1.3 qt.)	Coolant (📖 p. 149)
---------	-----------------	--------------------

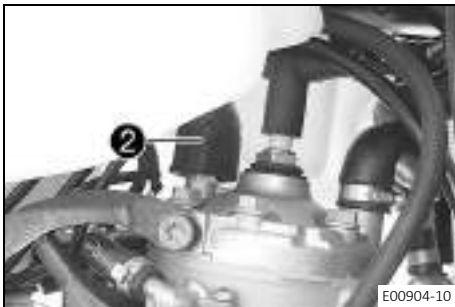

- Push protection cap **2** upward over the thermostat.

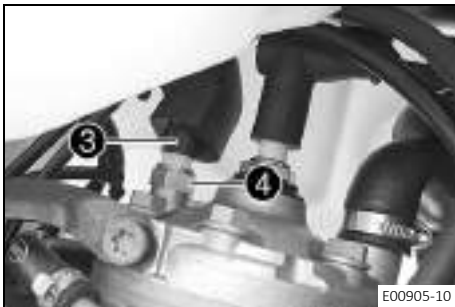

- Unplug connector **3**.
- Remove thermostat **4** with O-ring and wait until the coolant escapes without bubbles.
- Mount thermostat **4** with the O-ring and tighten.

Guideline

Screw, cylinder head temperature sensor	M10x1.25	12 Nm (8.9 lbf ft)
---	----------	--------------------

- Plug in connector **3**.

- Position protection cap **2**.

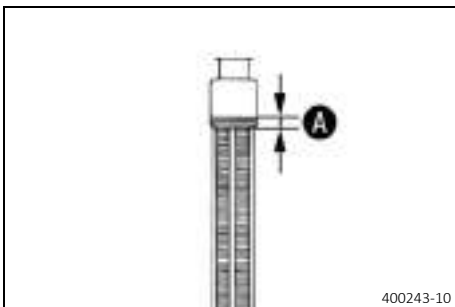

- Pour coolant in up to measurement **A** above the radiator fins.

Guideline

10 mm (0.39 in)
-----------------

Coolant (📖 p. 149)
--------------------



- Mount radiator cap **5**.



### Danger

**Danger of poisoning** Exhaust gases are toxic and inhaling them may result in unconsciousness and death.

- Always make sure there is sufficient ventilation when running the engine.
- Use effective exhaust extraction when starting or running the engine in an enclosed space.

- Allow the engine to warm up and cool down again.

**Finishing work**

- Check the coolant level. (📖 p. 112)



**16.6 Changing the coolant**



**Warning**

**Danger of scalding** During motorcycle operation, the coolant gets very hot and is under pressure.

- Do not open the radiator, the radiator hoses or other cooling system components if the engine or the cooling system are at operating temperature.
- Allow the cooling system and the engine to cool down before you open the radiator, the radiator hoses or other components of the cooling system.
- In the event of scalding, rinse the area affected immediately with lukewarm water.



**Warning**

**Danger of poisoning** Coolant is toxic and a health hazard.

- Keep coolant out of the reach of children.
- Do not allow coolant to come into contact with the skin, the eyes and clothing.
- Consult a doctor immediately if coolant is swallowed.
- Rinse the affected area immediately with plenty of water in the event of contact with the skin.
- Rinse eyes thoroughly with water and consult a doctor immediately if coolant gets into the eyes.
- Change clothing if coolant spills onto your clothing.

**Condition**

The engine is cold.

- Remove screw ❶. Take off radiator cap ❷.
- Place an appropriate container under the water pump cover.
- Completely drain the coolant.
- Mount and tighten screw ❶ with a new seal ring.

Guideline

Screw, water pump cover	M6	10 Nm (7.4 lbf ft)
-------------------------	----	--------------------

- Position the motorcycle upright.
- Completely fill the radiator with coolant.

Coolant (📖 p. 149)
--------------------

- Push protection cap ❸ upward over the thermostat.

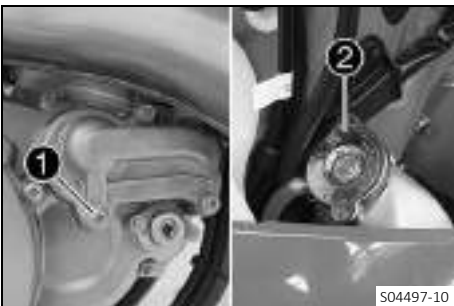

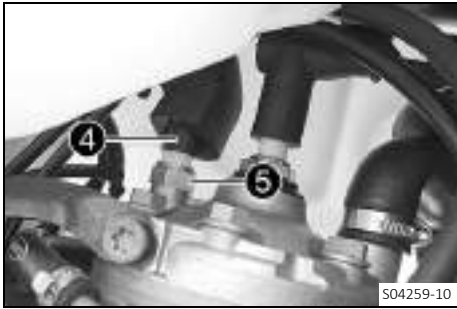

- Unplug connector ④.
- Remove thermostat ⑤ with O-ring and wait until the coolant escapes without bubbles.
- Mount thermostat ⑤ with the O-ring and tighten.

Guideline

Screw, cylinder head temperature sensor	M10x1.25	12 Nm (8.9 lbf ft)
---	----------	--------------------

- Plug in connector ④.
- Mount protection cap ③.
- Mount radiator cap ②.



### Danger

**Danger of poisoning** Exhaust gases are toxic and inhaling them may result in unconsciousness and death.

- Always make sure there is sufficient ventilation when running the engine.
- Use effective exhaust extraction when starting or running the engine in an enclosed space.

- Allow the engine to warm up and cool down again.
- Check the cooling system for leaks.
- Check the coolant level. (📖 p. 112)

**17.1 Checking the play in the throttle cable**

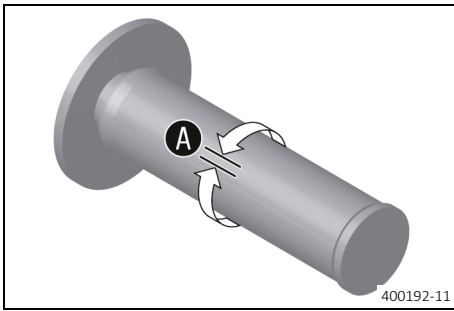

- Check the throttle grip for smooth operation.
- Turn handlebar as far as possible to the right. Turn the throttle grip back and forth slightly and determine the play in throttle cable **A**.

Play in throttle cable	3 ... 5 mm (0.12 ... 0.2 in)
------------------------	------------------------------

- » If the throttle cable play does not meet the specified value:
  - Adjust the play in the throttle cable. 🛠️ (p. 117)



**Danger**

**Danger of poisoning** Exhaust gases are toxic and inhaling them may result in unconsciousness and death.

- Always make sure there is sufficient ventilation when running the engine.
- Use effective exhaust extraction when starting or running the engine in an enclosed space.

- Start the engine and let it run at idle speed. Move the handlebar to and fro over the entire steering range.

The idle speed must not change.
---------------------------------

- » If the idle speed changes:
  - Adjust the play in the throttle cable. 🛠️ (p. 117)



**17.2 Adjusting the play in the throttle cable 🛠️**



**Info**

If the correct routing of the throttle cables has already been secured, the fuel tank does not need to be removed.

**Preparatory work**

- Remove the seat. (p. 64)
- Remove the fuel tank. 🛠️ (p. 70)
- Check the throttle cable routing. (p. 78)

**Main work**

- Move the handlebar to the straight-ahead position.
- Push back sleeve **1**.
- Loosen nut **2**.
- Turn adjusting screw **3** in as far as possible.
- Loosen nut **4**.
- Turn adjusting screw **5** in as far as possible.
- Turn adjusting screw **3** so that there is play in the throttle cable at the throttle grip.

Guideline

Play in throttle cable	3 ... 5 mm (0.12 ... 0.2 in)
------------------------	------------------------------

- Unscrew the adjusting screw **5** until the smooth operation or play in throttle cable is worsened.
- Turn adjusting screw **5** approx. two turns further.
- Tighten nut **4**.
- Tighten nut **2**.

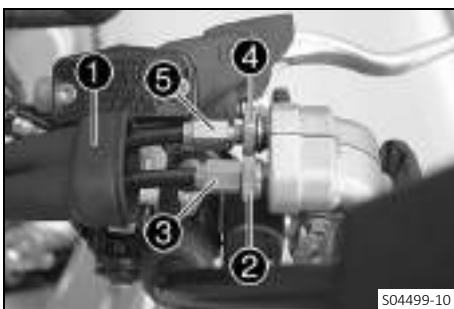

- Slide on sleeve ①.
- Check the throttle grip for smooth operation.

### Finishing work

- Check the play in the throttle cable. (📖 p. 117)

## 17.3 Setting the characteristic map of the throttle response ↩

### **i** Info

On the throttle grip, the characteristic map of the throttle response is changed by changing the guide plate. A guide plate with a different characteristic map is supplied.

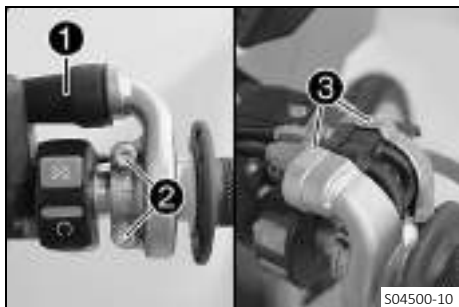

### Main work

- Push back sleeve ①.
- Remove screws ② and half-shells ③.
- Detach the throttle cables and take off the grip tube.

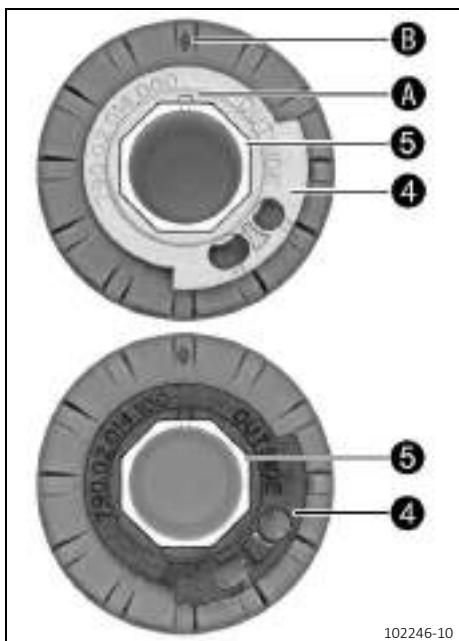

- Remove guide plate ④ from handle tube ⑤.
- Position the required guide plate on the grip tube.

### Guideline

The label **OUTSIDE** must be visible. Marking **A** must be positioned at marking **B**.

Grey guide plate (79002014000)

### Alternative 1

Black guide plate (79002014100)

### **i** Info

The gray guide plate opens the throttle valve more slowly. The black guide plate opens the throttle valve more quickly. The gray guide plate is mounted upon delivery.



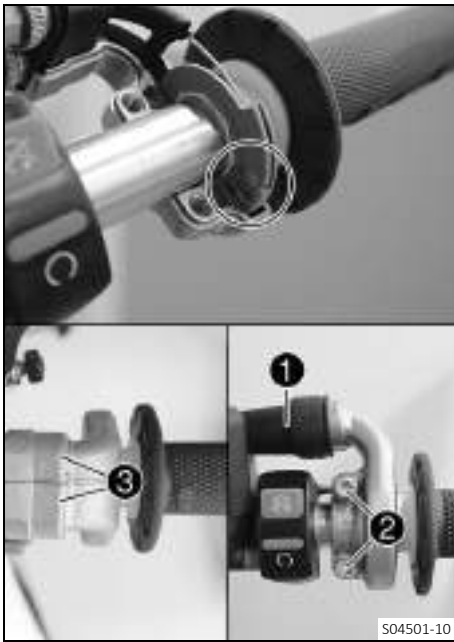

- Clean the outside of the handlebar and the inside of the grip tube. Mount the grip tube on the handlebar.
- Attach the throttle cables to the guide plate and route correctly.
- Position half-shells ③, mount and tighten screws ②.

Guideline

Screw, throttle grip	M6	5 Nm (3.7 lbf ft)
----------------------	----	-------------------

- Slide on sleeve ① and check the throttle grip for ease of movement.

### Finishing work

- Check the play in the throttle cable. (🔧 p. 117)



## 17.4 Adjusting the idle speed 🛠️



### Warning

**Danger of accidents** The engine may go out spontaneously if the idle speed is set too low.

- Set the idle speed to the specified value. (Your authorized GASGAS Motorcycles workshop will be glad to help.)

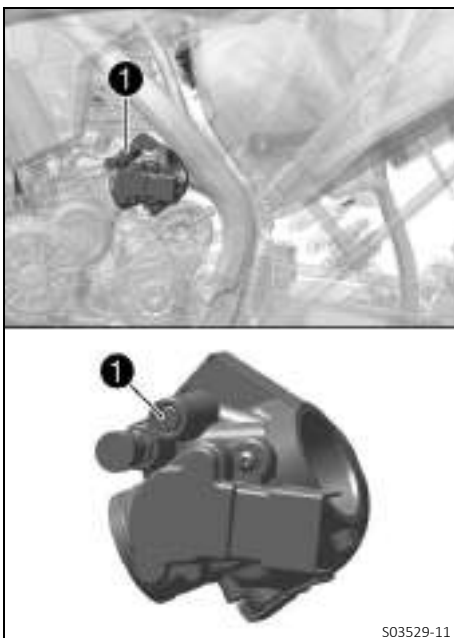

- Run the engine until warm.
- ✓ The cold start button is deactivated – A further ¼ turn returns the cold start button back to the basic position. (🔧 p. 19)



### Danger

**Danger of poisoning** Exhaust gases are toxic and inhaling them may result in unconsciousness and death.

- Always make sure there is sufficient ventilation when running the engine.
- Use effective exhaust extraction when starting or running the engine in an enclosed space.

- Adjust the idle speed by turning idle speed adjusting screw ①.

Guideline

Idle speed	1,400 ... 1,500 rpm
------------	---------------------

Tachometer (45129075000)
--------------------------

## **i** Info

Turn clockwise to decrease the idle speed.  
 Turn counterclockwise to increase the idle speed.  
 Make the setting in small steps.  
 An incorrect idle speed can have a negative impact on overall engine running.

### 17.5 Programming ambient air pressure



#### **Danger**

**Danger of poisoning** Exhaust gases are toxic and inhaling them may result in unconsciousness and death.

- Always make sure there is sufficient ventilation when running the engine.
- Use effective exhaust extraction when starting or running the engine in an enclosed space.



#### **Info**

If the vehicle is ridden with the engine running at various heights above sea level, the ambient pressure is programmed on an ongoing basis.  
 If the vehicle is transported over great differences in height, the ambient pressure must be reprogrammed.

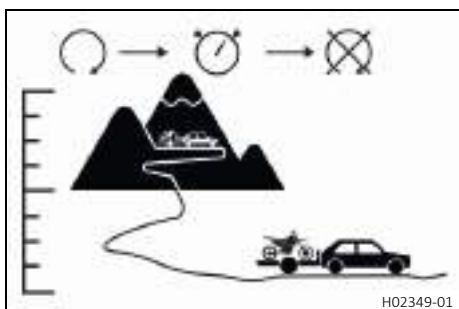

- Start the vehicle at the new height above sea level and switch off the engine again.
- Wait for at least five seconds.
- Start the vehicle again and check the response of the vehicle.
  - » If the response has not improved:
    - Repeat the procedure.

### 17.6 Ignition curve plug-in connector

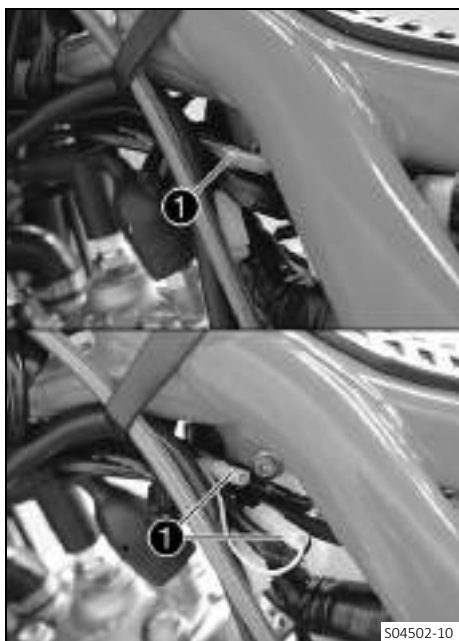

Plug-in connector **1** of the ignition timing map adjustment is located on the frame under the fuel tank.

## **i** Info

The ignition timing map connector has no function in the homologated (restricted) condition of the motorcycle.

#### **Possible states**

- Soft – The plug-in connector of the ignition timing map adjustment is disconnected to achieve better rideability.
- Performance – The plug-in connector of the ignition timing map adjustment is joined to achieve higher performance.

17.7 Changing the ignition timing map

**i** Info

The ignition timing map connector has no function in the homologated (restricted) condition of the motorcycle.

**Preparatory work**

- Remove the seat. (📖 p. 64)
- Remove the fuel tank. 🛠️ (📖 p. 70)

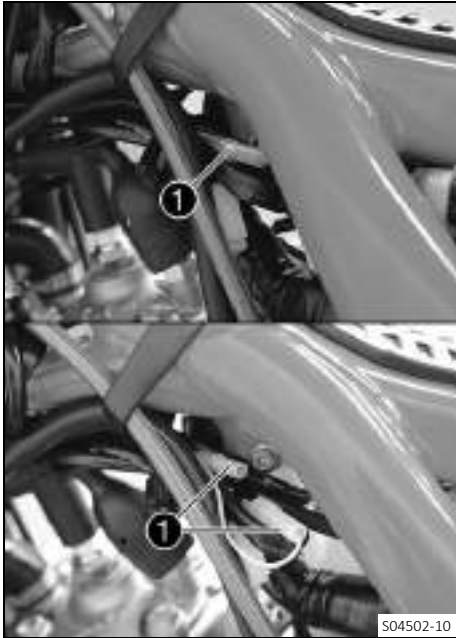

**Switching the ignition timing map from Performance to Soft**

- Disconnect plug-in connector **1** of the ignition timing map adjustment.
  - ✓ Soft – better rideability

**Switching the ignition timing map from Soft to Performance**

- Join plug-in connector **1** of the ignition timing map adjustment.
  - ✓ Performance – better performance

**Finishing work**

- Install the fuel tank. 🛠️ (📖 p. 71)
- Mount the seat. (📖 p. 65)



17.8 Checking the basic position of the shift lever

**i** Info

When driving, the shift lever must not touch the rider's boot when in the basic position. When the shift lever keeps touching the boot, the transmission will be subject to an excessive load.

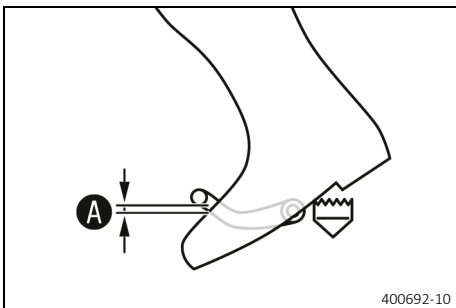

- Sit on the vehicle in the riding position and determine distance **A** between the upper edge of your boot and the shift lever.

Distance between shift lever and upper edge of boot	10 ... 20 mm (0.39 ... 0.79 in)
---	---------------------------------

- » If the distance does not meet specifications:
  - Adjust the basic position of the shift lever. 🛠️ (📖 p. 122)



## 17.9 Adjusting the basic position of the shift lever

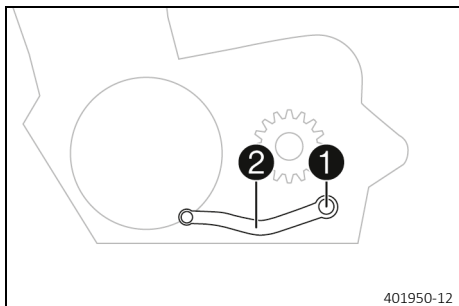

- Remove screw ① with the washers and take off shift lever ②.

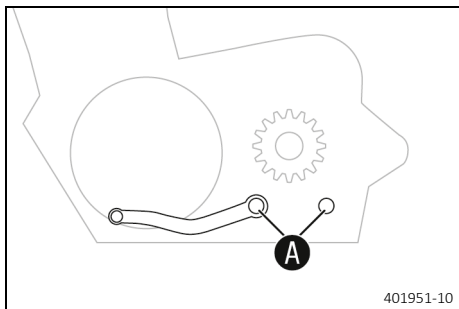

- Clean gear teeth A of the shift lever and shift shaft.
- Mount the shift lever on the shift shaft in the required position and engage gearing.

### **i** Info

The range of adjustment is limited.

The shift lever must not come into contact with any other vehicle components during the shift procedure.

- Mount and tighten screw ① with the washers.

### Guideline

Screw, shift lever	M6	14 Nm (10.3 lbf ft) <b>Loctite®243™</b>
--------------------	----	--

18.1 Changing the fuel screen ↩



**Danger**

**Fire hazard** Fuel is highly flammable.

The fuel in the fuel tank expands when warm and can escape if overfilled.

- Do not fuel the vehicle in the vicinity of open flames or lit cigarettes.
- Switch off the engine for refueling.
- Make sure that no fuel is spilled; particularly not on hot parts of the vehicle.
- If any fuel is spilled, wipe it off immediately.
- Observe the specifications for refueling.



**Warning**

**Danger of poisoning** Fuel is poisonous and a health hazard.

- Avoid skin, eye and clothing contact with fuel.
- Immediately consult a doctor if you swallow fuel.
- Do not inhale fuel vapors.
- In case of skin contact, rinse the affected area with plenty of water.
- Rinse the eyes thoroughly with water, and consult a doctor in case of fuel contact with the eyes.
- Change your clothing in case of fuel spills on them.



**Note**

**Environmental hazard** Improper handling of fuel is a danger to the environment.

- Do not allow fuel to enter the groundwater, the soil, or the sewage system.

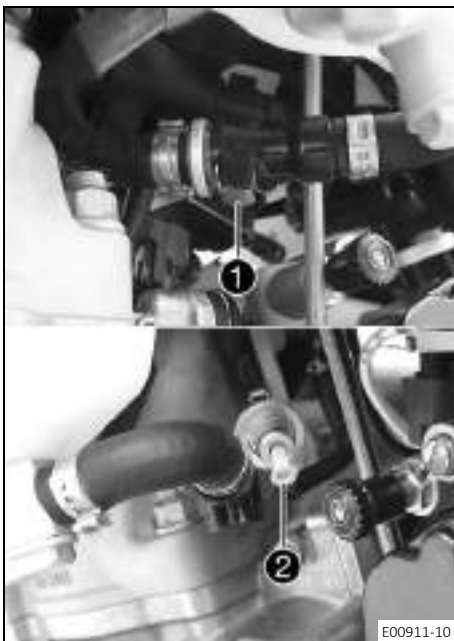

- Clean quick release coupling ① thoroughly with compressed air.



**Info**

Under no circumstances should dirt enter into the fuel line. Dirt in the fuel line clogs the injection valve!

- Disconnect the quick release coupling.



**Info**

Remaining fuel may flow out of the fuel hose.

- Pull fuel screen ② out of the connecting piece.
- Insert the new fuel screen all the way into the connecting piece.
- Spray silicone spray onto a lint-free cleaning cloth and lightly lubricate the O-ring of the quick-release coupling.

Silicone spray (📖 p. 151)

- Join the quick release coupling.



**Danger**

**Danger of poisoning** Exhaust gases are toxic and inhaling them may result in unconsciousness and death.

- Always make sure there is sufficient ventilation when running the engine.
- Use effective exhaust extraction when starting or running the engine in an enclosed space.

- Start the engine and check the response.



## 18.2 Checking 2-stroke oil level



### Warning

**Engine failure** The engine will not be lubricated unless there is 2-stroke oil in the oil tank.

If the oil level warning light lights up, the 2-stroke oil is sufficient for the remaining tank of fuel.

- As soon as the oil level warning light lights up, ride for no longer than until the remaining fuel in the tank is depleted.
- At the next opportunity add 2-stroke oil before you refuel.
- Time the oil pump if the 2-stroke oil hose has been removed or the 2-stroke oil tank has been fully depleted in error.



### Preparatory work

- Stand the motorcycle upright on a horizontal surface.

### Main work

- Check the 2-stroke oil level in the oil tank.



### Info

For a full tank of fuel, the 2-stroke oil tank must be filled up to at least the upper abutting edge **A**.

The 2-stroke oil tank must be completely filled if possible.

- » If the 2-stroke oil level is too low:
  - Add 2-stroke oil. (📖 p. 38)

## 18.3 Priming oil pump 🛠️



### Warning

**Engine failure** The engine will not be lubricated unless there is 2-stroke oil in the oil tank.

If the oil level warning light lights up, the 2-stroke oil is sufficient for the remaining tank of fuel.

- As soon as the oil level warning light lights up, ride for no longer than until the remaining fuel in the tank is depleted.
- At the next opportunity add 2-stroke oil before you refuel.
- Time the oil pump if the 2-stroke oil hose has been removed or the 2-stroke oil tank has been fully depleted in error.

### Condition

The engine is off.

### Preparatory work

- Remove the seat. (📖 p. 64)
- Stand the motorcycle upright on a horizontal surface.
- Check 2-stroke oil level. (📖 p. 124)



S04503-10

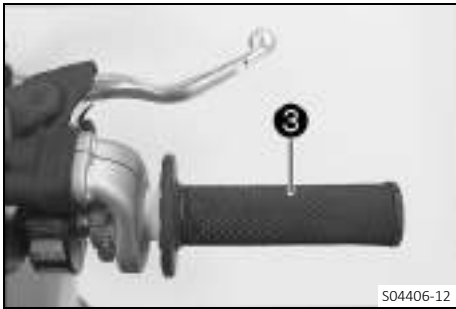

S04406-12

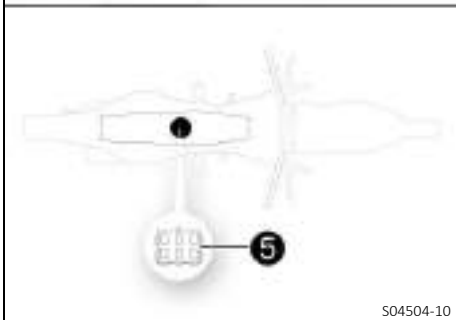

S04504-10

### Main work

- Pull the EFI control unit **1** upward off the rubber plugs and hang to the side.
- Remove protection cap **2** of the diagnostics connector.

- Put throttle grip **3** into full throttle position and secure.

- Plug in wake-up connector **4** for priming the oil pump to the diagnostics connector **5**.

✓ The combination instrument lighting is activated.

- Wait for at least five seconds.

- Release the fixing means from the throttle grip.

✓ The oil pump is timed.

### **i** Info

The oil pump is actuated at various speeds.  
The procedure is clearly audible.

- Wait until you can no longer hear the oil pump operating.
- Disconnect the wake-up connector from the diagnostics connector.



- Check whether air bubbles are visible in the hose ⑥.
  - » If air bubbles are visible:
    - Repeat the entire procedure until air bubbles are no longer visible.
- Mount protection cap on the diagnostics connector.
- Mount the EFI control unit on the rubber lugs.

### Finishing work

- Mount the seat. (📖 p. 65)

## 18.4 Cleaning the oil screen in the oil tank 🛠️



### Note

**Environmental hazard** Hazardous substances cause environmental damage.

- Dispose of oils, grease, filters, fuel, cleaning agents, brake fluid, etc., correctly and in compliance with the applicable regulations.

### Preparatory work

- Raise the motorcycle with a lift stand. (📖 p. 52)
- Remove main silencer. (📖 p. 68)
- Remove the seat. (📖 p. 64)
- Remove the fuel tank. 🛠️ (📖 p. 70)
- Remove the air filter box cover. (📖 p. 65)

### Main work

- Remove screws ①.
- Loosen screws ②.

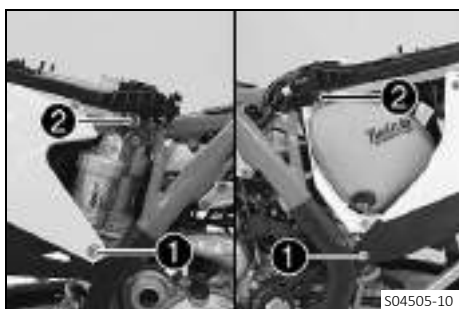



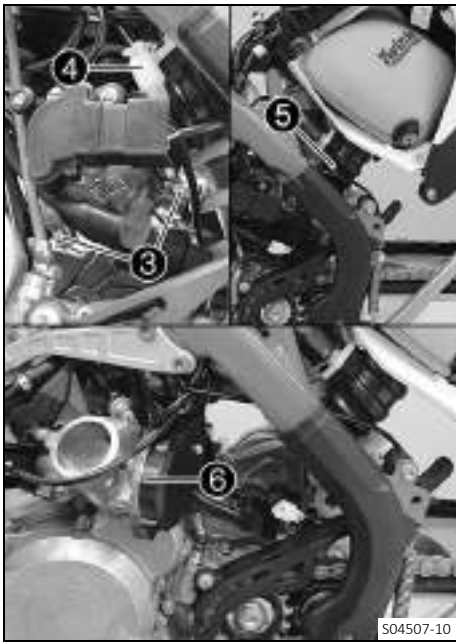

- Loosen clamps ③ of the throttle valve body.
- Disconnect plug-in connector ④ of the rear brake light switch.
- Lift the subframe slightly and secure it.



**Info**

Pay attention to intake flange ⑤.

- Pull throttle valve body ⑥ towards the rear, out of the intake flange, and hang it to the side.



- Open hose clamp ⑦ using a screwdriver.
- Pull off the angle piece and collect the 2-stroke oil in a suitable container.



- Remove oil screen ⑧ and clean it.
- Check the oil screen for damage.
  - » If the oil screen is damaged:
    - Change the oil screen.



- Insert the oil screen and mount the angle piece with a new hose clamp.

Hose clamp plier (60029057000)

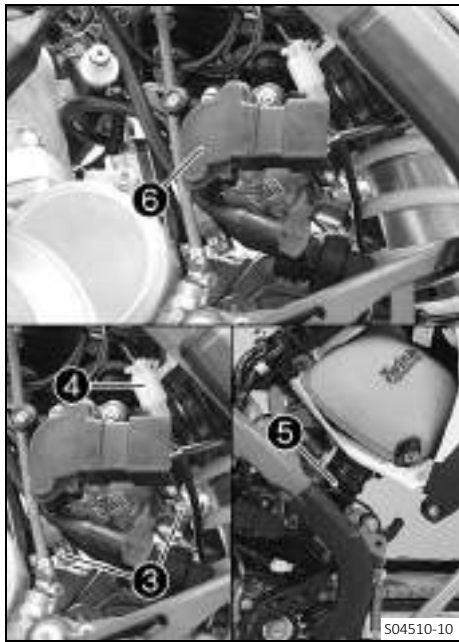

- Mount throttle valve body ⑥.
- Remove the locking piece and position the subframe.

**i Info**

Pay attention to intake flange ⑤.

- Join plug-in connector ④ of the rear brake light switch.
- Position and tighten clamps ③ of the throttle valve body.

Guideline

Screw, intake flange/reed valve housing	M6	6 Nm (4.4 lbf ft)
---	----	-------------------

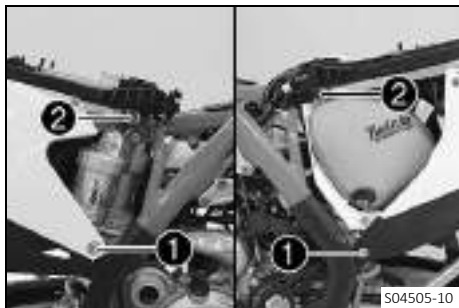

- Mount and tighten screws ①.

Guideline

Screw, subframe bottom	M8	30 Nm (22.1 lbf ft) <b>Loctite®2701™</b>
------------------------	----	---

- Remove screws ②.
- Mount and tighten screws ②.

Guideline

Screw, subframe top	M8	35 Nm (25.8 lbf ft) <b>Loctite®2701™</b>
---------------------	----	---

**Finishing work**

- Install the air filter box cover. (📖 p. 66)
- Install the fuel tank. 🛠️ (📖 p. 71)
- Add 2-stroke oil. (📖 p. 38)
- Prime the oil pump. 🛠️ (📖 p. 124)
- Mount the seat. (📖 p. 65)
- Install the main silencer. (📖 p. 69)
- Remove the motorcycle from the lift stand. (📖 p. 52)

## 18.5 Checking the gear oil level

**i Info**

The gear oil level must be checked when the engine is cold.

**Preparatory work**

- Stand the motorcycle upright on a horizontal surface.

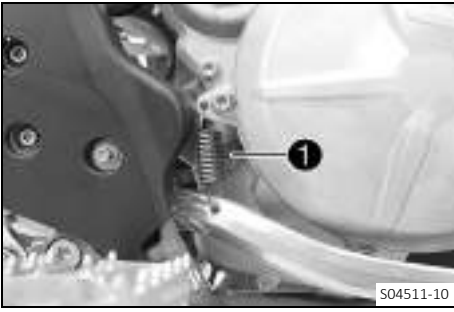

**Main work**

- Detach the foot brake lever spring.
- Remove gear oil level monitoring screw ❶.
- Check the gear oil level.

A small quantity of gear oil must run out of the drilled hole.

- » If no gear oil runs out:
  - Add the gear oil. 🛠️ (📖 p. 130)
- Mount and tighten the gear oil level monitoring screw.

Guideline

Screw, gear oil level monitoring	M6	8 Nm (5.9 lbf ft)
----------------------------------	----	-------------------

- Attach the foot brake lever spring.



**18.6 Changing the gear oil 🛠️**



**Warning**

**Danger of scalding** Engine and gear oil get very hot when the motorcycle is ridden.

- Wear suitable protective clothing and safety gloves.
- In the event of scalding, rinse the area affected immediately with lukewarm water.



**Note**

**Environmental hazard** Hazardous substances cause environmental damage.

- Dispose of oils, grease, filters, fuel, cleaning agents, brake fluid, etc., correctly and in compliance with the applicable regulations.



**Info**

Drain the gear oil while the engine is at operating temperature.

**Preparatory work**

- Park the motorcycle on a level surface.
- Position an appropriate container under the engine.

**Main work**

- Remove gear oil drain plug ❶ with magnet.
- Let the gear oil drain fully.
- Thoroughly clean the gear oil drain plug with magnet.
- Clean the sealing surface on the engine.
- Mount and tighten gear oil drain plug ❶ with the magnet and a new seal ring.

Guideline

Gear oil drain plug with magnet	M12x1.5	20 Nm (14.8 lbf ft)
---------------------------------	---------	---------------------



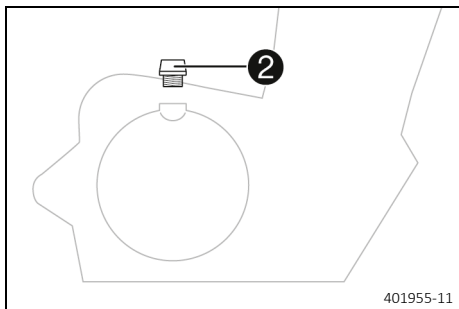

- Remove filler plug **2** with the O-ring, and fill up with gear oil.

Gear oil	0.80 l (0.85 qt.)	Engine oil (15W/50) (📖 p. 149)
----------	-------------------	-----------------------------------

- Mount and tighten the filler plug together with the O-ring.



### Danger

**Danger of poisoning** Exhaust gases are toxic and inhaling them may result in unconsciousness and death.

- Always make sure there is sufficient ventilation when running the engine.
- Use effective exhaust extraction when starting or running the engine in an enclosed space.

- Start the engine and check for leaks.

### Finishing work

- Check the gear oil level. (📖 p. 128)

## 18.7 Adding the gear oil 🛠️



### Info

Too little gear oil or poor-quality gear oil results in premature wear to the transmission. Gear oil must only be topped up when the engine is cold.

### Preparatory work

- Park the motorcycle on a level surface.

### Main work

- Detach the foot brake lever spring.
- Remove gear oil level monitoring screw **1**.

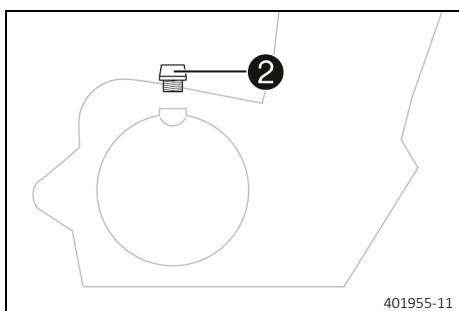
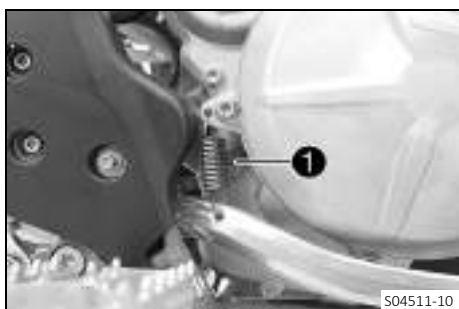

- Remove filler plug **2** with the O-ring.
- Add gear oil until it emerges from the drill hole of the gear oil level monitoring screw.

Engine oil (15W/50) (📖 p. 149)
--------------------------------

- Mount and tighten the gear oil level monitoring screw.

### Guideline

Screw, gear oil level monitoring	M6	8 Nm (5.9 lbf ft)
----------------------------------	----	-------------------

- Mount and tighten filler plug **2** with the O-ring.
- Attach the foot brake lever spring.

**Danger**

**Danger of poisoning** Exhaust gases are toxic and inhaling them may result in unconsciousness and death.

- Always make sure there is sufficient ventilation when running the engine.
- Use effective exhaust extraction when starting or running the engine in an enclosed space.

- Start the engine and check for leaks.

**Finishing work**

- Check the gear oil level. (📖 p. 128)



## 19.1 Cleaning the motorcycle

### Note

**Material damage** Components become damaged or destroyed if a pressure cleaner is used incorrectly.

The high pressure forces water into the electrical components, connectors, throttle cables, and bearings, etc. Pressure which is too high causes malfunctions and destroys components.

- Do not direct the water jet directly on to electrical components, connectors, throttle cables or bearings.
- Maintain a minimum distance between the nozzle of the pressure cleaner and the component.  
Minimum clearance 60 cm (23.6 in)



### Note

**Environmental hazard** Hazardous substances cause environmental damage.

- Dispose of oils, grease, filters, fuel, cleaning agents, brake fluid, etc., correctly and in compliance with the applicable regulations.



### Info

To maintain the value and appearance of the motorcycle over a long period, clean it regularly. Avoid direct sunshine when cleaning the motorcycle.

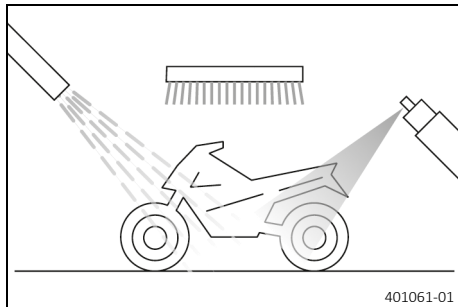

- Close off exhaust system to keep water from entering.
- Remove the coarse dirt particles with a gentle water jet.
- Spray the heavily soiled parts with a normal commercial motorcycle cleaner and clean using a brush.

Motorcycle cleaner (📖 p. 151)



### Info

Use warm water containing normal motorcycle cleaner and a soft sponge. Never apply motorcycle cleaner to a dry vehicle; always rinse the vehicle with water first.

- After rinsing the motorcycle with a gentle spray of water, allow it to dry thoroughly.
- Remove the closure of the exhaust system.



### Warning

**Danger of accidents** Moisture and dirt impair the brake system.

- Brake carefully several times to dry out and remove dirt from the brake linings and the brake discs.

- After cleaning, ride the vehicle a short distance until the engine warms up.



### Info

The heat produced causes water at inaccessible locations in the engine and on the brake system to evaporate.

- After the motorcycle has cooled down, lubricate all moving parts and pivot points.
- Clean the chain. (📖 p. 73)

- Treat bare metal (except for brake discs and the exhaust system) with a corrosion inhibitor.

Preserving materials for paints, metal and rubber (📖 p. 151)

- Treat all plastic parts and powder-coated parts with a mild cleaning and care product.

Special cleaner for glossy and matte paint finishes, metal and plastic surfaces (📖 p. 152)

**(All EU models)**

- Oil the steering lock.

Universal oil spray (📖 p. 152)



**19.2 Checks and maintenance steps for winter operation**

**i Info**

If you use the motorcycle in winter, salt can be expected on the roads. You should therefore take precautions against aggressive road salt. If the vehicle has been used on salted roads, use cold water for cleaning after riding. Warm water enhances the corrosive effects of salt.

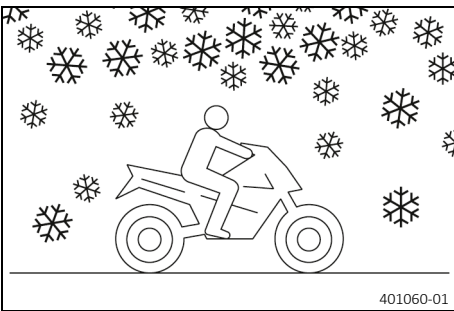

- Clean the motorcycle. (📖 p. 132)
- Clean the brakes.

**i Info**

After **EVERY** trip on salted roads, thoroughly clean the brake calipers and brake linings, after they have cooled down and without removing them, with cold water and dry them carefully. After riding on salted roads, thoroughly clean the vehicle with cold water and dry it well.

- Treat engine, link fork, and all other bare or zinc-plated parts (except the brake discs) with a wax-based corrosion inhibitor.

**i Info**

Corrosion inhibitor must not come in contact with the brake discs as this would greatly reduce the braking force.

- Clean the chain. (📖 p. 73)



## 20.1 Storage



### Warning

**Danger of poisoning** Fuel is poisonous and a health hazard.

- Avoid skin, eye and clothing contact with fuel.
- Immediately consult a doctor if you swallow fuel.
- Do not inhale fuel vapors.
- In case of skin contact, rinse the affected area with plenty of water.
- Rinse the eyes thoroughly with water, and consult a doctor in case of fuel contact with the eyes.
- Change your clothing in case of fuel spills on them.
- Keep fuels correctly in a suitable canister, and out of the reach of children.



### Info

If you plan to garage the motorcycle for a longer period, perform the following steps or have them performed. Before storing the motorcycle, check all parts for function and wear. If service, repairs, or replacements are necessary, you should do this during the storage period (less workshop overload). In this way, you can avoid long workshop waiting times at the start of the new season.

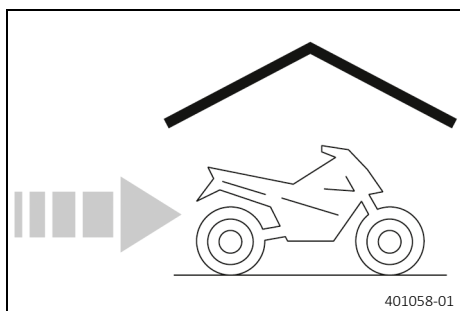

- Clean the motorcycle. (📖 p. 132)
- Change the gear oil. 🛠️ (📖 p. 129)
- Check the antifreeze and coolant level. (📖 p. 111)
- When refueling for the last time before taking the motorcycle out of service, add fuel additive.

Fuel additive (📖 p. 151)
--------------------------

- Refuel. (📖 p. 37)
- Add 2-stroke oil. (📖 p. 38)
- Check tire pressure. (📖 p. 97)
- Remove the 12-V battery. 🛠️ (📖 p. 99)
- Charge the 12-V battery. 🛠️ (📖 p. 102)

#### Guideline

Ideal charging and storage temperature of the lithium-ion battery	10 ... 20 °C (50 ... 68 °F)
---	-----------------------------

- Store the vehicle in a dry location that is not subject to large fluctuations in temperature.



### Info

GASGAS Motorcycles recommends jacking up the motorcycle.

- Raise the motorcycle with a lift stand. (📖 p. 52)
- Cover the vehicle with a tarp or a similar cover that is permeable to air.



**Info**

Do not use non-porous materials since they prevent humidity from escaping, thus causing corrosion. Avoid running the engine for a short time only. Because the engine will not warm up sufficiently, the water vapor produced during combustion will condense, causing engine parts and the exhaust system to rust.

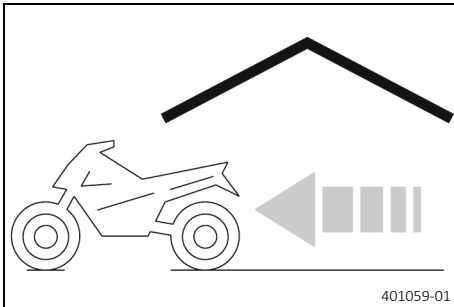
**20.2 Preparing for use after storage**

- Remove the motorcycle from the lift stand. (📖 p. 52)
- Install the 12-V battery. 🛠️ (📖 p. 100)
- Perform checks and maintenance measures when preparing for use. (📖 p. 34)
- Make a test ride.



Faults	Possible cause	Action
The engine cannot be cranked (starter motor)	Operating error	– Carry out the start procedure. (📖 p. 34)
	12-V battery discharged	– Charge the 12-V battery. 🛠️ (📖 p. 102) – Check the charging voltage. 🛠️ – Check the closed current. 🛠️ – Check the stator winding of the alternator. 🛠️
	Main fuse is blown	– Change the main fuse. (📖 p. 103)
	Starter relay faulty	– Check the starter relay. 🛠️
	Starter motor faulty	– Check the starter motor. 🛠️
The engine turns but does not start	Operating error	– Carry out the start procedure. (📖 p. 34)
	Quick release coupling not joined	– Join quick release coupling.
	Idle speed is not set correctly	– Adjust the idle speed. 🛠️ (📖 p. 119)
	Fuel supply interrupted	– Check the fuel tank breather.
	Spark plug oily or wet	– Clean and dry the spark plug, or change it if necessary.
	Plug gap of spark plug too wide	– Adjust plug gap. Guideline Spark plug electrode gap 0.6 mm (0.024 in)
	Faulty ignition	– Ignition coil - check the primary winding. 🛠️ – Check the spark plug connector. 🛠️ – Check the stator winding of the alternator. 🛠️
	Short-circuit cable in wiring harness frayed, stop button or emergency OFF switch faulty	– Check wiring harness (visual check). – Check the electrical system.
	The connector or ignition coil is loose or oxidized	– Clean the connector and treat it with contact spray.
Error in the electronic fuel injection	– Check wiring for damage and electrical plug-in connectors for corrosion and damage. – Read out the fault memory using the GAS-GAS Motorcycles diagnostics tool. 🛠️	
The engine has no idle speed	Spark plug defective	– Change the spark plug.
	Faulty ignition	– Ignition coil - check the primary winding. 🛠️ – Check the spark plug connector. 🛠️ – Check the stator winding of the alternator. 🛠️
	Idle speed is not set correctly	– Adjust the idle speed. 🛠️ (📖 p. 119)
Engine does not speed up	Error in the electronic fuel injection	– Check wiring for damage and electrical plug-in connectors for corrosion and damage. – Read out the fault memory using the GAS-GAS Motorcycles diagnostics tool. 🛠️







<b>Faults</b>	<b>Possible cause</b>	<b>Action</b>
Engine does not speed up	Faulty ignition	<ul style="list-style-type: none"> <li>– Ignition coil - check the primary winding. 🛠️</li> <li>– Check the spark plug connector. 🛠️</li> <li>– Check the stator winding of the alternator. 🛠️</li> </ul>
	Ambient pressure is incorrectly stored	– Program ambient air pressure. (📖 p. 120)
Engine has too little power	Air filter very dirty	– Clean the air filter and air filter box. 🛠️ (📖 p. 67)
	Fuel filter is very dirty	– Change the fuel filter. 🛠️
	Fuel screen is very dirty	– Change the fuel screen. 🛠️ (📖 p. 123)
	Error in the electronic fuel injection	<ul style="list-style-type: none"> <li>– Check wiring for damage and electrical plug-in connectors for corrosion and damage.</li> <li>– Read out the fault memory using the GAS-GAS Motorcycles diagnostics tool. 🛠️</li> </ul>
	Fuel supply interrupted	– Check the fuel tank breather.
	Exhaust system leaky, deformed or too little glass fiber yarn filling in main silencer	<ul style="list-style-type: none"> <li>– Check exhaust system for damage.</li> <li>– Change the glass fiber yarn filling of the main silencer. 🛠️ (📖 p. 69)</li> </ul>
	Faulty ignition	<ul style="list-style-type: none"> <li>– Ignition coil - check the primary winding. 🛠️</li> <li>– Check the spark plug connector. 🛠️</li> <li>– Check the stator winding of the alternator. 🛠️</li> </ul>
	Diaphragm or reed valve housing damaged	– Check the diaphragm and reed valve housing.
The engine dies during the trip	Lack of fuel	– Refuel. (📖 p. 37)
	The engine takes in false air	– Check that the intake flange is firmly seated.
	The connector or ignition coil is loose or oxidized	– Clean the connector and treat it with contact spray.
	Ambient pressure is incorrectly stored	– Program ambient air pressure. (📖 p. 120)
Engine overheats	Too little coolant in cooling system	<ul style="list-style-type: none"> <li>– Check the cooling system for leakage.</li> <li>– Check the coolant level. (📖 p. 112)</li> </ul>
	Too little air stream	– Switch off engine when stationary.
	Radiator fins very dirty	– Clean the radiator fins.
	Foam formation in cooling system	<ul style="list-style-type: none"> <li>– Drain the coolant. 🛠️ (📖 p. 112)</li> <li>– Refill with coolant. 🛠️ (📖 p. 113)</li> </ul>
	Damaged cylinder head or cylinder head gasket	– Check the cylinder head and cylinder head gasket.
	Bent radiator hose	– Change the radiator hose. 🛠️
	Thermostat defective	<ul style="list-style-type: none"> <li>– Check the thermostat. 🛠️</li> </ul> <p>Guideline Opening temperature: 70 °C (158 °F)</p>







## 21 TROUBLESHOOTING

Faults	Possible cause	Action
White smoke emission (steam in exhaust gas)	Damaged cylinder head or cylinder head gasket	– Check the cylinder head and cylinder head gasket.
Gear oil exits at the vent hose	Too much gear oil added	– Check the gear oil level. (📖 p. 128)
Water in the gear oil	Damaged radial shaft seal ring or water pump	– Check the radial shaft seal ring and the water pump.
Malfunction indicator lamp lights up or flashes	Error in the electronic fuel injection	– Check wiring for damage and electrical plug-in connectors for corrosion and damage. – Read out the fault memory using the GAS-GAS Motorcycles diagnostics tool. 🛠️
12-V battery discharged	The 12-V battery is not being charged by the alternator	– Check the charging voltage. 🛠️ – Check the stator winding of the alternator. 🛠️
	Unwanted electrical power consumer	– Check the open-circuit current. 🛠️
Values in combination instrument deleted (time, stop watch, lap times)	The combination instrument battery is empty	– Change combination instrument battery. (📖 p. 109)

**Info**

The blink codes are only displayed by the derestricted version of the vehicle.

<b>Blink code for malfunction indicator lamp</b>	 14 Malfunction indicator lamp flashes 1x long, 4x short
<b>Error level condition</b>	Crankcase pressure sensor – difference too high between sensor and engine electronics control unit
<b>Blink code for malfunction indicator lamp</b>	 09 Malfunction indicator lamp flashes 9x short
<b>Error level condition</b>	Crankcase pressure sensor - short circuit to ground
	Crankcase pressure sensor - open/short circuit to plus
	Ambient air pressure sensor – short circuit to ground
	Ambient air pressure sensor – open/short circuit to plus
<b>Blink code for malfunction indicator lamp</b>	 13 Malfunction indicator lamp flashes 1x long, 3x short
<b>Error level condition</b>	Intake air temperature sensor – input signal too low
	Intake air temperature sensor – input signal too high
<b>Blink code for malfunction indicator lamp</b>	 12 Malfunction indicator lamp flashes 1x long, 2x short
<b>Error level condition</b>	Coolant temperature sensor – input signal too low
	Coolant temperature sensor – input signal too high
<b>Blink code for malfunction indicator lamp</b>	 06 Malfunction indicator lamp flashes 6x short
<b>Error level condition</b>	Throttle valve position sensor circuit A - adaption failed
	Throttle valve position sensor circuit A – input signal too low
	Throttle valve position sensor circuit A – input signal too high
<b>Blink code for malfunction indicator lamp</b>	 41 Malfunction indicator lamp flashes 4x long, 1x short
<b>Error level condition</b>	Fuel pump - short circuit to ground/open circuit
	Fuel pump – open circuit/short circuit to plus
<b>Blink code for malfunction indicator lamp</b>	 33 Malfunction indicator lamp flashes 3x long, 3x short
<b>Error level condition</b>	Injection valve 0, cylinder 1 – input signal too low
	Injection valve 0, cylinder 1 - input signal too high

<b>Blink code for malfunction indicator lamp</b>	 34 Malfunction indicator lamp flashes 3x long, 4x short
<b>Error level condition</b>	Injection valve 1, cylinder 1 – input signal too low
	Injection valve 1, cylinder 1 - input signal too high
<b>Blink code for malfunction indicator lamp</b>	 37 Malfunction indicator lamp flashes 3x long, 7x short
<b>Error level condition</b>	Ignition coil – circuit fault
<b>Blink code for malfunction indicator lamp</b>	 02 Malfunction indicator lamp flashes 2x short
<b>Error level condition</b>	Crankshaft speed sensor – synchronization faulty
	Crankshaft speed sensor – signal implausible
	Crankshaft speed sensor – signal irregular
	Crankshaft speed sensor – no signal
<b>Blink code for malfunction indicator lamp</b>	 42 Malfunction indicator lamp flashes 4x long, 2x short
<b>Error level condition</b>	Oil pump – input signal too low
	Oil pump - input signal too high
<b>Blink code for malfunction indicator lamp</b>	 21 Malfunction indicator lamp flashes 2x long, 1x short
<b>Error level condition</b>	Battery voltage - input voltage too low
	Battery voltage – input voltage too high
<b>Blink code for malfunction indicator lamp</b>	 Malfunction indicator lamp lights up
<b>Error level condition</b>	Tilt sensor – input signal too low
	Tilt sensor – input signal too high

**23.1 Engine**
**23.1.1 EC 250 EU**

Design	1-cylinder 2-stroke engine, water-cooled, with reed intake, exhaust control and transfer duct injection
Displacement	249 cm <sup>3</sup> (15.19 cu in)
Stroke	72 mm (2.83 in)
Hole	66.4 mm (2.614 in)
Idle speed	1,400 ... 1,500 rpm
Exhaust control - setting measurement	2.7 ± <sub>0</sub> <sup>0.2</sup> mm (0.106 ± <sub>0</sub> <sup>0.008</sup> in)
Crankshaft bearing	1 grooved ball bearing/1 roller bearing
Conrod bearing	Needle bearing
Piston pin bearing	Needle bearing
Piston	Cast aluminum
Piston rings	2 half keystone rings
Engine lubrication	Separate lubrication
X distance (upper edge of piston to upper edge of cylinder)	0 ... 0.10 mm (0 ... 0.0039 in)
Z distance (height of control flap)	49.0 mm (1.929 in)
Primary transmission	26:73
Clutch	Multidisc clutch in oil bath/hydraulically activated
Transmission	6 gear transmission, claw shifted
Transmission ratio	
first-gear	14:32
second-gear	16:26
third-gear	20:25
fourth-gear	22:23
fifth-gear	25:22
sixth-gear	26:20
Alternator	12 V, 196 W
Ignition system	Contactless controlled fully electronic ignition with digital ignition adjustment
Spark plug	NGK BR 7 ES
Spark plug electrode gap	0.6 mm (0.024 in)
Cooling	Water cooling, permanent circulation of coolant by water pump
Starting aid	Electric starter system

**23.1.2 All 300 models**

Design	1-cylinder 2-stroke engine, water-cooled, with reed intake, exhaust control and transfer duct injection
Displacement	293.15 cm <sup>3</sup> (17.8892 cu in)
Stroke	72 mm (2.83 in)
Hole	72 mm (2.83 in)
Idle speed	1,400 ... 1,500 rpm
Exhaust control - setting measurement	2.3 ± <sub>0</sub> <sup>0.2</sup> mm (0.091 ± <sub>0</sub> <sup>0.008</sup> in)
Crankshaft bearing	1 grooved ball bearing/1 roller bearing
Conrod bearing	Needle bearing

Piston pin bearing	Needle bearing
Piston	Cast aluminum
Piston rings	2 rectangular rings
Engine lubrication	Separate lubrication
X distance (upper edge of piston to upper edge of cylinder)	0 ... 0.10 mm (0 ... 0.0039 in)
Z distance (height of control flap)	49.5 mm (1.949 in)
Primary transmission	26:73
Clutch	Multidisc clutch in oil bath/hydraulically activated
Transmission	6 gear transmission, claw shifted
Transmission ratio	
first-gear	14:32
second-gear	16:26
third-gear	20:25
fourth-gear	22:23
fifth-gear	25:22
sixth-gear	26:20
Alternator	12 V, 196 W
Ignition system	Contactless controlled fully electronic ignition with digital ignition adjustment
Spark plug	NGK BR 7 ES
Spark plug electrode gap	0.6 mm (0.024 in)
Cooling	Water cooling, permanent circulation of coolant by water pump
Starting aid	Electric starter system

## 23.2 Motor tightening torques

Screw, inner membrane sheets	EJOTDELTA PT® 35x25	1 Nm (0.7 lbf ft)	
Screw, membrane support plate	EJOTDELTA PT® 30x12	1 Nm (0.7 lbf ft)	
Screw, outer membrane sheets	EJOTDELTA PT® 30x6	1 Nm (0.7 lbf ft)	
Screw, angle lever, exhaust control	M5	6 Nm (4.4 lbf ft)	Loctite®243™
Screw, bearing retainer	M5	6 Nm (4.4 lbf ft)	Loctite®243™
Screw, clutch spring retainer	M5	6 Nm (4.4 lbf ft)	
Screw, crankshaft speed sensor	M5	6 Nm (4.4 lbf ft)	Loctite®243™
Screw, exhaust control bearing support	M5	6 Nm (4.4 lbf ft)	Loctite®243™
Screw, exhaust control cap	M5	5 Nm (3.7 lbf ft)	
Screw, exhaust control cover	M5	5 Nm (3.7 lbf ft)	
Screw, injection valve holder	M5	5 Nm (3.7 lbf ft)	Loctite®243™
Screw, locking lever	M5	6 Nm (4.4 lbf ft)	Loctite®243™
Screw, retaining bracket of exhaust control	M5	6 Nm (4.4 lbf ft)	Loctite®2701™
Screw, stator	M5	6 Nm (4.4 lbf ft)	Loctite®2701™



Cap nut, water pump impeller	M6	5 Nm (3.7 lbf ft)	<b>Loctite® 243™</b>
Drain plug, water pump cover	M6	10 Nm (7.4 lbf ft)	
Screw, alternator cover	M6	8 Nm (5.9 lbf ft)	
Screw, clutch slave cylinder	M6	10 Nm (7.4 lbf ft)	
Screw, control flap, exhaust control	M6	10 Nm (7.4 lbf ft)	<b>Loctite® 243™</b>
Screw, engine case	M6	10 Nm (7.4 lbf ft)	
Screw, exhaust control thrust bearing	M6	8 Nm (5.9 lbf ft)	<b>Loctite® 243™</b>
Screw, exhaust flange	M6	8 Nm (5.9 lbf ft)	
Screw, gear oil level monitoring	M6	8 Nm (5.9 lbf ft)	
Screw, intake flange/reed valve housing	M6	6 Nm (4.4 lbf ft)	
Screw, intermediate clutch cover	M6	10 Nm (7.4 lbf ft)	
Screw, kick starter intermediate gear pin	M6	10 Nm (7.4 lbf ft)	<b>Loctite® 243™</b>
Screw, outer clutch cover	M6	8 Nm (5.9 lbf ft)	
Screw, shift drum locating	M6	10 Nm (7.4 lbf ft)	<b>Loctite® 243™</b>
Screw, shift lever	M6	14 Nm (10.3 lbf ft)	<b>Loctite® 243™</b>
Screw, starter motor	M6	10 Nm (7.4 lbf ft)	
Screw, starter motor bearing bush	M6	10 Nm (7.4 lbf ft)	<b>Loctite® 243™</b>
Screw, starter motor protection cap	M6	8 Nm (5.9 lbf ft)	
Screw, water pump cover	M6	10 Nm (7.4 lbf ft)	
Vacuum connection, cylinder	M6	4 Nm (3 lbf ft)	<b>Loctite® 2701™</b>
Screw, balancer shaft	M8	30 Nm (22.1 lbf ft)	<b>Loctite® 243™</b>
Screw, cylinder head	M8	27 Nm (19.9 lbf ft)	
Nut, cylinder base	M10	35 Nm (25.8 lbf ft)	
Screw, drive chain engine sprocket	M10	60 Nm (44.3 lbf ft)	<b>Loctite® 2701™</b>
Stud, cylinder base	M10	20 Nm (14.8 lbf ft)	
Screw, cylinder head temperature sensor	M10x1.25	12 Nm (8.9 lbf ft)	
Nut, rotor	M12x1	60 Nm (44.3 lbf ft)	
Gear oil drain plug with magnet	M12x1.5	20 Nm (14.8 lbf ft)	
Spark plug	M14x1.25	25 Nm (18.4 lbf ft)	
Nut, inner clutch hub	M18x1.5	100 Nm (73.8 lbf ft)	<b>Loctite® 648™</b>
Nut, primary gear wheel	M18LHx1.5	150 Nm (110.6 lbf ft)	<b>Loctite® 648™</b>

## 23.3 Capacities

### 23.3.1 Gear oil

Gear oil	0.80 l (0.85 qt.)	Engine oil (15W/50) (📖 p. 149)
----------	-------------------	--------------------------------

### 23.3.2 Coolant

Coolant	1.2 l (1.3 qt.)	Coolant (📖 p. 149)
---------	-----------------	--------------------

### 23.3.3 Fuel

Total fuel tank capacity, approx.	8.5 l (2.25 US gal)	Super unleaded (ROZ 95) (📖 p. 150)
-----------------------------------	---------------------	------------------------------------

Fuel reserve, approx.	1.5 l (1.6 qt.)	
-----------------------	-----------------	--

2-stroke oil tank content approx.	0.6 l (0.6 qt.)	Engine oil, 2-stroke (📖 p. 149)
-----------------------------------	-----------------	---------------------------------

## 23.4 Chassis

Frame	Central tube frame made of chrome molybdenum steel tubing	
Fork	<b>WP XPLOR</b>	
Shock absorber	<b>WPXACT 5750</b>	
Suspension travel		
front	300 mm (11.81 in)	
Fork offset	22 mm (0.87 in)	
Brake system	Disc brakes, floating brake calipers	
Brake discs - diameter		
front	260 mm (10.24 in)	
rear	220 mm (8.66 in)	
Brake discs - wear limit		
front	2.5 mm (0.098 in)	
rear	3.5 mm (0.138 in)	
Offroad tire pressure		
front	1.0 bar (15 psi)	
rear	1.0 bar (15 psi)	
Secondary ratio (EC 250 EU)	14:52 (13:52)	
Secondary ratio (All 300 models)	14:50 (13:50)	
Chain	5/8 x 1/4"	
Rear sprockets available	45, 48, 49, 50, 51, 52	
Steering head angle	63.5°	
Wheelbase	1,482 ± 10 mm (58.35 ± 0.39 in)	
Seat height unloaded	960 mm (37.8 in)	
Ground clearance unloaded	360 mm (14.17 in)	
Weight without fuel, approx.	108 kg (238 lb.)	
Maximum permissible front axle load	145 kg (320 lb.)	
Maximum permissible rear axle load	190 kg (419 lb.)	
Maximum permissible overall weight	335 kg (739 lb.)	

**23.5 Electrical system**

12-V battery	HJTZ5S-FP-C	Lithium-ion battery Battery voltage: 12 V Nominal capacity: 2.0 Ah Maintenance-free
Combination instrument battery	CR 2032	Battery voltage: 3 V
Fuse	75011088005	5 A
Fuse	75011088010	10 A
Fuse	58011109120	20 A
Headlight	S2 / socket BA20d	12 V 35/35 W
Position light	W5W / socket W2.1x9.5d	12 V 5 W
Indicator lamps	W2.3W / socket W2x4.6d	12 V 2.3 W
Turn signal (All EU models)	R10W / socket BA15s	12 V 10 W
Brake/tail light	LED	

**23.6 Tires**

Validity	Front tire	Rear tire
(All EU models)	<b>90/90 - 21 M/C 54R M+S TT</b> MAXXIS Maxx EnduPro	<b>140/80 - 18 M/C 70R M+S TT</b> MAXXIS Maxx EnduPro
(EC 300 US)	<b>80/100 - 21 M/C 51M TT</b> Dunlop GEOMAX AT81F	<b>110/100 - 18 M/C 64M TT</b> Dunlop GEOMAX AT81

The tires specified represent one of the possible series production tires. Additional information is available in the Service section under:  
<http://www.gasgas.com>

**23.7 Fork**

Fork article number	A540C163U401000
Fork	<b>WP XPLOr</b>
Compression damping	
Comfort	18 clicks
Standard	15 clicks
Sport	12 clicks
Rebound damping	
Comfort	18 clicks
Standard	15 clicks
Sport	12 clicks
Spring length with preload spacer(s)	474 mm (18.66 in)
Spring rate	
Weight of rider: 65 ... 75 kg (143 ... 165 lb.)	4.0 N/mm (22.8 lb/in)
Weight of rider: 75 ... 85 kg (165 ... 187 lb.)	4.2 N/mm (24 lb/in)
Weight of rider: 85 ... 95 kg (187 ... 209 lb.)	4.4 N/mm (25.1 lb/in)
Fork length	928 mm (36.54 in)

Fork oil per fork leg	615 ± 10 ml (20.79 ± 0.34 fl. oz.)	Fork oil (SAE 4) (48601166S1) (📖 p. 150)
-----------------------	------------------------------------	---

## 23.8 Shock absorber

Shock absorber article number	18.15.7T.69
Shock absorber	<b>WPXACT 5750</b>
Lowspeed compression damping	
Comfort	17 clicks
Standard	15 clicks
Sport	13 clicks
Highspeed compression damping	
Comfort	2.5 turns
Standard	2 turns
Sport	1.5 turns
Rebound damping	
Comfort	17 clicks
Standard	15 clicks
Sport	13 clicks
Spring preload	10 mm (0.39 in)
Spring rate	
Weight of rider: 65 ... 75 kg (143 ... 165 lb.)	39 N/mm (223 lb/in)
Weight of rider: 75 ... 85 kg (165 ... 187 lb.)	42 N/mm (240 lb/in)
Weight of rider: 85 ... 95 kg (187 ... 209 lb.)	45 N/mm (257 lb/in)
Spring length	260 mm (10.24 in)
Gas pressure	10 bar (145 psi)
Static sag	37 mm (1.46 in)
Riding sag	110 mm (4.33 in)
Fitted length	477 mm (18.78 in)
Shock absorber fluid (📖 p. 150)	SAE 2.5

## 23.9 Chassis tightening torques

Remaining screws, chassis	<b>EJOT PT®</b> K60x25-Z	2 Nm (1.5 lbf ft)
Screw, intake air temperature sensor	<b>EJOTDELTA PT®</b> 45x12-Z	0.7 Nm (0.52 lbf ft)
Screw, oil fill level sensor	<b>G 3/4 "</b>	7 Nm (5.2 lbf ft)
Screw, oil pump holder on oil tank	<b>EJOTDELTA PT</b> 45x12-Z	0.7 Nm (0.52 lbf ft)
Screw, pressure regulator	<b>EJOT PT®</b> K60x25-Z	2.3 Nm (1.7 lbf ft)
Screw, seat fixing	<b>EJOTEJOFORM PT®</b> K60x23/18	2.5 Nm (1.84 lbf ft)
Screw, stop button (EC 300 US)	M3	0.4 Nm (0.3 lbf ft)
Screw, emergency OFF switch (All EU models)	M4	0.4 Nm (0.3 lbf ft)
Screw, fixed grip	M4	5 Nm (3.7 lbf ft)
Spoke nipple, front wheel	M4.5	6 Nm (4.4 lbf ft)
Spoke nipple, rear wheel	M4.5	6 Nm (4.4 lbf ft)
Remaining nuts, chassis	M5	5 Nm (3.7 lbf ft)
Remaining screws, chassis	M5	5 Nm (3.7 lbf ft)

**Loctite®243™**

Screw, battery terminal	M5	2.5 Nm (1.84 lbf ft)	
Screw, brake line guide for link fork	M5	5 Nm (3.7 lbf ft)	
Screw, ground wire in tail section	M5	5 Nm (3.7 lbf ft)	
Screw, light switch (All EU models)	M5	1 Nm (0.7 lbf ft)	
Screw, shock absorber adjusting ring	M5	5 Nm (3.7 lbf ft)	
Nut, cable on starter motor	M6	4 Nm (3 lbf ft)	
Remaining nuts, chassis	M6	10 Nm (7.4 lbf ft)	
Remaining screws, chassis	M6	10 Nm (7.4 lbf ft)	
Screw, ball joint of push rod on foot brake cylinder	M6	10 Nm (7.4 lbf ft)	<b>Loctite®243™</b>
Screw, battery support bracket	M6	6 Nm (4.4 lbf ft)	
Screw, brake lever	M6	5 Nm (3.7 lbf ft)	
Screw, cable on starter relay	M6	6 Nm (4.4 lbf ft)	
Screw, chain guide	M6	10 Nm (7.4 lbf ft)	
Screw, chain sliding guard	M6	6 Nm (4.4 lbf ft)	<b>Loctite®243™</b>
Screw, clutch lever	M6	5 Nm (3.7 lbf ft)	
Screw, front brake disc	M6	14 Nm (10.3 lbf ft)	<b>Loctite®243™</b>
Screw, manifold on silent block	M6	6 Nm (4.4 lbf ft)	
Screw, oil pump	M6	7 Nm (5.2 lbf ft)	
Screw, rear brake disc	M6	14 Nm (10.3 lbf ft)	<b>Loctite®243™</b>
Screw, seat fixing	M6	10 Nm (7.4 lbf ft)	
Screw, silent block on frame	M6	6 Nm (4.4 lbf ft)	
Screw, throttle grip	M6	5 Nm (3.7 lbf ft)	
Fuel connection on fuel pump	M8	15 Nm (11.1 lbf ft)	
Nut, foot brake lever	M8	20 Nm (14.8 lbf ft)	
Nut, foot brake lever stop	M8	20 Nm (14.8 lbf ft)	
Nut, fuel pump	M8	15 Nm (11.1 lbf ft)	
Nut, rear sprocket screw	M8	35 Nm (25.8 lbf ft)	<b>Loctite®2701™</b>
Nut, rim lock	M8	12 Nm (8.9 lbf ft)	
Remaining nuts, chassis	M8	25 Nm (18.4 lbf ft)	
Remaining screws, chassis	M8	25 Nm (18.4 lbf ft)	
Screw, bottom triple clamp	M8	15 Nm (11.1 lbf ft)	
Screw, chain sliding piece	M8	15 Nm (11.1 lbf ft)	
Screw, engine brace	M8x15	25 Nm (18.4 lbf ft)	<b>Loctite®2701™</b>
Screw, engine brace	M8x20	25 Nm (18.4 lbf ft)	<b>Loctite®243™</b>
Screw, engine sprocket cover	M8	15 Nm (11.1 lbf ft)	
Screw, fork stub	M8	15 Nm (11.1 lbf ft)	
Screw, front brake caliper	M8	25 Nm (18.4 lbf ft)	<b>Loctite®243™</b>
Screw, handlebar clamp	M8	20 Nm (14.8 lbf ft)	
Screw, manifold	M8	15 Nm (11.1 lbf ft)	
Screw, side stand attachment (EC 300 US)	M8x20	33 Nm (24.3 lbf ft)	<b>Loctite®2701™</b>

Screw, side stand attachment (All EU models)	M8x26	33 Nm (24.3 lbf ft)	<b>Loctite®2701™</b>
Screw, subframe bottom	M8	30 Nm (22.1 lbf ft)	<b>Loctite®2701™</b>
Screw, subframe top	M8	35 Nm (25.8 lbf ft)	<b>Loctite®2701™</b>
Screw, top steering stem	M8	20 Nm (14.8 lbf ft)	
Screw, top triple clamp	M8	20 Nm (14.8 lbf ft)	
Engine bracket screw	M10	60 Nm (44.3 lbf ft)	
Remaining nuts, chassis	M10	45 Nm (33.2 lbf ft)	
Remaining screws, chassis	M10	45 Nm (33.2 lbf ft)	
Screw, bottom shock absorber	M10	60 Nm (44.3 lbf ft)	<b>Loctite®2701™</b>
Screw, handlebar support	M10	40 Nm (29.5 lbf ft)	<b>Loctite®243™</b>
Screw, top shock absorber	M10	60 Nm (44.3 lbf ft)	<b>Loctite®2701™</b>
Nut, fork pivot	M16x1.5	100 Nm (73.8 lbf ft)	
Nut, rear wheel spindle	M20x1.5	80 Nm (59 lbf ft)	
Screw, front wheel spindle	M20x1.5	35 Nm (25.8 lbf ft)	
Screw, top steering head	M20x1.5	12 Nm (8.9 lbf ft)	
Screw-in fitting, cooling system	M24x1.5	18 Nm (13.3 lbf ft)	<b>Loctite®243™</b>

**Brake fluid DOT 4 / DOT 5.1****Standard/classification**

- DOT

**Guideline**

- Use only brake fluid that complies with the specified standard (see specifications on the container) and that exhibits the corresponding properties.

**Recommended supplier****Castrol**

- **REACT PERFORMANCE DOT 4**

**MOTOREX®**

- **Brake Fluid DOT 5.1**

**Coolant****Guideline**

- Only use high-grade, silicate-free coolant with corrosion inhibitor additive for aluminum motors. Low grade and unsuitable antifreeze causes corrosion, deposits and frothing.
- Do not use pure water as only coolant is able to meet the requirements needed in terms of corrosion protection and lubrication properties.
- Only use coolant that complies with the requirements stated (see specifications on the container) and that has the relevant properties.

Antifreeze protection to at least	-25 °C (-13 °F)
-----------------------------------	-----------------

The mixture ratio must be adjusted to the necessary antifreeze protection. Use distilled water if the coolant needs to be diluted.

The use of premixed coolant is recommended.

Observe the coolant manufacturer specifications for antifreeze protection, dilution and miscibility (compatibility) with other coolants.

**Recommended supplier****MOTOREX®**

- **COOLANT M3.0**

**Engine oil (15W/50)****Standard/classification**

- JASO T903 MA2 (📖 p. 153)
- SAE (📖 p. 153) (15W/50)

**Guideline**

- Use only engine oils that comply with the specified standards (see specifications on the container) and that possess the corresponding properties.

**Recommended supplier****MOTOREX®**

- **Top Speed 4T**

**Engine oil, 2-stroke****Standard/classification**

- JASO FD (📖 p. 153)

**Guideline**

- Only use high-grade 2-stroke engine oil from a reputable brand.

fully synthetic
-----------------

**Recommended supplier****MOTOREX®**

- **Cross Power 2T**

### Fork oil (SAE 4) (48601166S1)

**Standard/classification**

- SAE (📖 p. 153) (SAE 4)

**Guideline**

- Use only oils that comply with the specified standards (see specifications on the container) and that exhibit the corresponding properties.

### Shock absorber fluid (SAE 2.5) (50180751S1)

**Standard/classification**

- SAE (📖 p. 153) (SAE 2.5)

**Guideline**

- Use only oils that comply with the specified standards (see specifications on the container) and that exhibit the corresponding properties.

### Super unleaded (ROZ 95)

**Standard/classification**

- DIN EN 228 (ROZ 95)

**Guideline**

- Only use super unleaded fuel that matches or is equivalent to the specified standard.
- Fuel with an ethanol content of up to 10% (E10 fuel) is safe to use.

**Info**

Do **not** use fuel containing methanol (e.g., M15, M85, M100) or more than 10% ethanol (e.g., E15, E25, E85, E100).

---



**Air filter cleaner**

Recommended supplier

MOTOREX®

- Racing Bio Dirt Remover

**Chain cleaner**

Recommended supplier

MOTOREX®

- Chain Clean

**Fuel additive**

Recommended supplier

MOTOREX®

- Fuel Stabilizer

**High viscosity grease**

Recommended supplier

SKF®

- LGHB 2

**Long-life grease**

Recommended supplier

MOTOREX®

- Bike Grease 2000

**Motorcycle cleaner**

Recommended supplier

MOTOREX®

- Moto Clean

**Off-road chain spray**

Recommended supplier

MOTOREX®

- Chainlube Offroad

**Oil for foam air filter**

Recommended supplier

MOTOREX®

- Racing Bio Liquid Power

**Preserving materials for paints, metal and rubber**

Recommended supplier

MOTOREX®

- Moto Protect

**Silicone spray**

Recommended supplier

MOTOREX®

- Silicone Spray

### Special cleaner for glossy and matte paint finishes, metal and plastic surfaces

Recommended supplier

MOTOREX®

- Quick Cleaner

### Universal oil spray

Recommended supplier

MOTOREX®

- Joker 440 Synthetic

### JASO T903 MA2

Different technical development directions required a separate specification for motorcycles – the **JASO T903 MA2** standard.

Earlier, engine oils from the automobile industry were used for motorcycles because there was no separate motorcycle specification.

Whereas long service intervals are demanded for automobile engines, the focus for motorcycle engines is on high performance at high engine speeds.

In most motorcycle engines, the transmission and clutch are lubricated with the same oil.

The **JASO T903 MA2** standard meets these special requirements.

### SAE

The SAE viscosity classes were defined by the Society of Automotive Engineers and are used for classifying oils according to their viscosity. The viscosity describes only one property of oil and says nothing about quality.

### JASO FD

JASO FD is a classification for a 2-stroke engine oil that was specifically developed for the extreme demands of racing.

Thanks to first-rate synthetic esters and specially designed additives, superb combustion is achieved even under extreme operating conditions.

TPI	Injection into transfer ducts (Transfer Port Injection)	Electronic fuel injection in which two injection valves in the transfer ducts of the cylinders are used
OBD	On-board diagnosis	Vehicle system, which monitors the specified parameters of the vehicle electronics

Art. no.	Article number
ca.	circa
cf.	compare
e.g.	for example
etc.	et cetera
i.a.	inter alia
no.	number
poss.	possibly



## 29.1 Red symbols

Red symbols indicate an error condition that requires immediate intervention.

	<p>The oil level warning lamp lights up red – Oil level has reached the <b>MIN</b> marking. Ride for no more than until the remaining fuel in the tank is depleted and at the next opportunity refuel with 2-stroke oil.</p>
---	--



## 29.2 Yellow and orange symbols

Yellow and orange symbols indicate an error condition that requires prompt intervention. Active driving aids are also represented by yellow or orange symbols.

	<p>Malfunction indicator lamp lights up/ flashes yellow – The OBD has detected an error in the vehicle electronics. Come safely to a halt, and contact an authorized GASGAS Motorcycles workshop.</p>
	<p>The fuel level warning lamp lights up yellow – The fuel level has reached the reserve mark.</p>

## 29.3 Green and blue symbols

Green and blue symbols reflect information.

	<p>The high beam indicator lamp lights up blue – The high beam is switched on.</p>
	<p>Turn signal indicator lamp flashes green – The turn signal is switched on.</p>

**1**

**12-V battery**  
 charging . . . . . 102  
 installing . . . . . 100  
 removing . . . . . 99  
 starting power . . . . . 29

**2**

**2-stroke oil level**  
 checking . . . . . 124

**2-stroke oil tank cap**  
 closing . . . . . 18  
 opening . . . . . 18

**A**

**Accessories** . . . . . 9

**Air filter**  
 cleaning . . . . . 67  
 installing . . . . . 67  
 removing . . . . . 66

**Air filter box**  
 cleaning . . . . . 67

**Air filter box cover**  
 installing . . . . . 66  
 preparing for securing . . . . . 68  
 removing . . . . . 65

**Ambient pressure**  
 programming . . . . . 120

**Antifreeze**  
 checking . . . . . 111

**Auxiliary substances** . . . . . 9

**B**

**Basic chassis setting**  
 rider's weight, checking with . . . . . 43

**Blink code** . . . . . 139-140

**Brake discs**  
 checking . . . . . 82

**Brake fluid**  
 of front brake, adding . . . . . 83  
 of rear brake, adding . . . . . 89

**Brake fluid level**  
 of front brake, checking . . . . . 83  
 rear brake, checking . . . . . 88

**Brake linings**  
 front brake, changing . . . . . 85  
 front brake, checking . . . . . 85  
 of the rear brake, changing . . . . . 90  
 rear brake, checking . . . . . 90

**C**

**Capacity**  
 coolant . . . . . 114, 144  
 fuel . . . . . 38, 144

Gear oil . . . . . 130, 144

**Chain**  
 checking . . . . . 75  
 cleaning . . . . . 73

**Chain guide**  
 checking . . . . . 75

**Chain tension**  
 adjusting . . . . . 74  
 checking . . . . . 74

**Characteristic map of the throttle response**  
 adjusting . . . . . 118

**Cleaning, care** . . . . . 132-133

**Clutch**  
 fluid level, checking/correcting . . . . . 79  
 fluid, changing . . . . . 80

**Clutch lever** . . . . . 14  
 basic position, adjusting . . . . . 79

**Cold start button** . . . . . 19

**Combination instrument**  
 adjusting . . . . . 22  
 clock, setting . . . . . 24  
 combination instrument battery, changing . . . . . 109  
 kilometers or miles, setting . . . . . 23  
 message . . . . . 22  
 overview . . . . . 22  
 service display, setting . . . . . 24

**Compression damping**  
 fork, adjusting . . . . . 49

**Coolant**  
 changing . . . . . 115  
 draining . . . . . 112  
 refilling . . . . . 113

**Coolant level**  
 checking . . . . . 111-112

**Cooling system** . . . . . 111

**Customer service** . . . . . 9

**D**

**Defined use** . . . . . 6

**Diagnostics connector** . . . . . 110

**Difficult operating conditions**  
 dry sand . . . . . 29  
 low temperature . . . . . 33  
 muddy surfaces . . . . . 32  
 snow . . . . . 33  
 wet sand . . . . . 31  
 wet surfaces . . . . . 32

**Difficult riding conditions** . . . . . 29  
 high temperatures . . . . . 32  
 slow speed . . . . . 32

**E**

**Emergency OFF switch** . . . . . 16

<b>Engine</b>	
running in	28
<b>Engine number</b>	12
<b>Engine sprocket</b>	
checking	75
<b>Environment</b>	8
<b>F</b>	
<b>Figures</b>	9
<b>Foot brake lever</b>	20
basic position, adjusting	88
free travel, checking	87
<b>Fork</b>	
article number	13
basic setting, checking	48
<b>Fork legs</b>	
bleeding	52
dust boots, cleaning	53
installing	55
removing	54
<b>Fork protector</b>	
installing	54
removing	53
<b>Frame</b>	
checking	78
<b>Front fender</b>	
installing	60
removing	60
<b>Front wheel</b>	
installing	94
removing	93
<b>Fuel screen</b>	
changing	123
<b>Fuel tank</b>	
installing	71
removing	70
<b>Fuel tank filler cap</b>	
closing	18
opening	17
<b>Fuel, oils, etc.</b>	9
<b>Fuse</b>	
changing for individual electrical power consumers	105
main fuse, changing	103
<b>G</b>	
<b>Gear oil</b>	
adding	130
changing	129
<b>Gear oil level</b>	
checking	128
<b>H</b>	
<b>Hand brake lever</b>	14
basic position, adjusting	82
free travel, checking	82
<b>Handlebar position</b>	50
adjusting	50
<b>Headlight</b>	
range, adjusting	109
<b>Headlight bulb</b>	
changing	107
<b>Headlight mask with headlight</b>	
installing	106
removing	106
<b>Headlight setting</b>	
checking	108
<b>High-speed compression damping</b>	
shock absorber, adjusting	44
<b>Horn button</b>	15
<b>I</b>	
<b>Idle speed</b>	
adjusting	119
<b>Idle speed adjusting screw</b>	19
<b>Ignition timing map</b>	
changing	121
plug-in connector	120
<b>Implied warranty</b>	9
<b>Intended use</b>	6
<b>K</b>	
<b>Key number</b>	12
<b>L</b>	
<b>Light switch</b>	15
<b>Link fork</b>	
checking	78
<b>Lower triple clamp</b>	
installing	56
removing	55
<b>Low-speed compression damping</b>	
shock absorber, adjusting	43
<b>M</b>	
<b>Main fuse</b>	
changing	103
<b>Main silencer</b>	
glass fiber yarn filling, changing	69
installing	69
removing	68
<b>Manufacturer warranty</b>	9
<b>Misuse</b>	6
<b>Motorcycle</b>	
cleaning	132
from lift stand, removing	52
raising with lift stand	52



**O**

**Oil pump**  
priming . . . . . 124

**Overview of indicator lamps** . . . . . 16-17

**Owner's Manual** . . . . . 8

**P**

**Play in throttle cable**  
adjusting . . . . . 117  
checking . . . . . 117

**Preparing for use**  
advice on preparing for first use . . . . . 27  
after storage . . . . . 135  
checks and maintenance measures when preparing  
for use . . . . . 34

**Protective clothing** . . . . . 7

**R**

**Rear sprocket**  
checking . . . . . 75

**Rear wheel**  
installing . . . . . 95  
removing . . . . . 94

**Rebound damping**  
fork, adjusting . . . . . 49  
shock absorber, adjusting . . . . . 45

**Refueling**  
2-stroke oil . . . . . 38  
fuel . . . . . 37

**Riding sag**  
adjusting . . . . . 48

**Rubber grip**  
checking . . . . . 79

**S**

**Safe operation** . . . . . 7

**Seat**  
mounting . . . . . 65  
removing . . . . . 64

**Service** . . . . . 9

**Service schedule** . . . . . 40-42

**Shift lever** . . . . . 20  
basic position, adjusting . . . . . 122  
basic position, checking . . . . . 121

**Shock absorber**  
article number . . . . . 13  
compression damping, general . . . . . 43  
installing . . . . . 63  
removing . . . . . 61  
riding sag, checking . . . . . 46  
spring preload, adjusting . . . . . 47  
static sag, checking . . . . . 46

**Side stand** . . . . . 20

**Spare parts** . . . . . 9

**Spoke tension**  
checking . . . . . 98

**Start button** . . . . . 16

**Starting** . . . . . 34

**Starting power of lithium-ion batteries at low  
temperatures** . . . . . 29

**Steering**  
locking . . . . . 21  
unlocking . . . . . 21

**Steering head bearing**  
lubricating . . . . . 60

**Steering head bearing play**  
adjusting . . . . . 59  
checking . . . . . 58

**Stop button** . . . . . 14-15

**Storage** . . . . . 134

**T**

**Technical data**  
capacities . . . . . 144  
chassis . . . . . 144  
chassis tightening torques . . . . . 146  
electrical system . . . . . 145  
engine . . . . . 141  
engine tightening torques . . . . . 142  
fork . . . . . 145  
shock absorber . . . . . 146  
tires . . . . . 145

**Throttle cable routing**  
checking . . . . . 78

**Throttle grip** . . . . . 14

**Tire condition**  
checking . . . . . 97

**Tire pressure**  
checking . . . . . 97

**Transporting** . . . . . 37

**Troubleshooting** . . . . . 136-138

**Turn signal bulb**  
changing . . . . . 108

**Turn signal switch** . . . . . 16

**Type label** . . . . . 12

**V**

**Vehicle identification number** . . . . . 12

**View of vehicle**  
front left . . . . . 10  
rear right . . . . . 11

**W**

**Winter operation**  
checks and maintenance steps . . . . . 133

**Work rules** . . . . . 8



3215011en

10/2020



Stallhofnerstraße 3 / 5230 Mattighofen / Austria / <http://www.gasgas.com>

