



SUPERSPORT

Owner's manual

ENGLISH

***SUPERSPORT
950***

***SUPERSPORT
950S***

Dear Ducatista,

thank you for trusting us with the purchase of your new Supersport.

We recommend that you **read the use and maintenance manual carefully**, to quickly get familiar with your Ducati and **make the most of all its features**. In the manual, we provide lots of useful advice and information on your **safety**, on how to **take care** of your bike and on how to maintain its value through **correct maintenance** by specialist Service Centres.

You can also find this manual in **digital format, always up-to-date, in the dedicated area of the Ducati website** and **in the MyDucati App**, which can be consulted both from a PC and a phone.



In this way, you will always have the **most up-to-date version of the manual** available and you will also find **information and frequently asked questions** regarding your bike and the world of Ducati.

You can send suggestions for improvement regarding the contents of this Use and maintenance manual to the following address: OwnerManual@ducati.com

This manual forms an integral part of the motorcycle and must be kept with it for its whole service life. If the motorcycle is resold, the manual must always be handed over to the new owner. The quality standards and safety of Ducati motorcycles are steadily improved as new design solutions, equipment and accessories are developed. While the information contained in this manual is current at the time of going to print, Ducati Motor Holding S.p.A. reserves the right to make changes at any time without notice and without any obligations. For this reason, the illustrations in this manual might differ from your motorcycle. Any and all reproduction or spreading of the contents herein in whole or in part is forbidden. All rights reserved to Ducati Motor Holding S.p.A. Any request for written authorisation shall be addressed to this company, specifying the reasons for request. For any servicing or suggestions you might need, please contact our authorised service centres.

For further information, please contact us at:

contact_us@ducati.com

Our Advisors are available to give you suggestions and useful tips.



Important

For further information, please contact the Ducati Support by clicking on "Contact us" in the Services and Maintenance section of the www.ducati.com website.

Our Advisors are available to give you suggestions and useful tips.

Enjoy your ride!

Roadside assistance



Important

The "ACI Global Services" roadside assistance is in force only in the following countries:

Denmark, Belgium, France, Luxembourg, Switzerland, Ireland, United Kingdom, Italy, Norway, Holland, Spain, Austria, Germany, Sweden, Portugal, Canary Islands, Cyprus, Croatia, Czech Republic, Estonia, Latvia, Lithuania, Finland, Greece, Hungary, Malta, Poland, Serbia and Montenegro, Slovakia, Slovenia, Turkey, Ukraine.

The Ducati Card Assistance Programme, created in collaboration with Ducati and ACI Global Services, offers assistance in case of breakdown and/or accident to the Ducati Customer. The service is active 24 hours a day, 365 days a year, for 24 months (in case of extended warranty the relevant conditions will apply) from the date of delivery of the

motorcycle or for the period of coverage of the Ever Red warranty extension.

The roadside assistance services include:

- Roadside assistance and towing
- Transport of passengers following roadside assistance
- Return of passengers or continuation of the journey
- Recovery of the repaired motorcycle
- Repatriation of the motorcycle from abroad
- Search and sending of spare parts abroad
- Hotel expenses
- Recovery of the motorcycle off the road in case of accident
- Advance payment of bail abroad

and may be requested in the following countries: Andorra, Austria, Belgium, Bulgaria, Croatia, Cyprus, Czech Republic, Estonia, Finland, France (including Corsica, roads open to ordinary traffic) Fyrom (the former Yugoslav Republic of Macedonia), Germany, Gibraltar, Greece, Hungary, Ireland, Iceland, Italy (including San Marino and the Vatican), Latvia, Lithuania, Luxembourg, Malta, Montenegro, the Netherlands, Norway, Poland, Portugal, Monaco,

Romania, Serbia, Slovakia, Slovenia, Spain, Sweden, Switzerland, Turkey, Ukraine, United Kingdom.



Important

All information is detailed and available on the Ducati website of the respective country.

Call Centre telephone numbers

The numbers to contact to request the services listed above are the following:

Andorra	+34-91-594 93 40	+34-91-594 93 40
Austria	0800-22 03 50	+43-1-25 119 19398
Belgium	0800-14 134	+32-2-233 22 90
Bulgaria	(02)-986 73 52	+359-2-986 73 52
Cyprus	22 31 31 31	+357-22-31 31 31
Croatia	0800-79 87	+385-1-464 01 41
Denmark	80 20 22 07	+45-80 20 22 07
Estonia	(0)-69 79 199	+372-69 79 199
Finland	(09)-77 47 64 00	+358-9-7747640 0

France (+Corsica)	0800-23 65 10	+33-4-72 17 12 83
FYROM	(02)-3181 192	+389-2-3181 192
Germany	0800-27 22 774	+49-89-76 76 40 90
Gibraltar	91-594 93 40	+34-91-594 93 40
Greece	(210)-9462 058	+30-210-9462 058
Ireland	1800-304 500	+353-1-617 95 61
Iceland	5 112 112	+354-5 112 112
Italy	800 744 444	+39 02 66.16.56.10
Latvia	67 56 65 86	+371-67 56 65 86
Lithuania	(85)-210 44 25	+370-5-210 44 25
Luxembourg	25 36 36 301	+352-25 36 36 301
Malta	21 24 69 68	+356-21 24 69 68
Monaco	+33-4-72 17 12 83	+33-4-72 17 12 83
Montenegro	0800-81 986	+382-20-234 038

Norway	800-30 466	+47-800-30 466
Holland	0800-099 11 20	+31-70-314 51 12
Poland	061 83 19 885	+48 61 83 19 885
Portugal	800-20 66 68	+351-21-942 91 05
United Kingdom	00800-33 22 88 77	00800-33 22 88 77
Czech Republic	261 10 43 48	+420-2-61 10 43 48
Romania	021-317 46 90	+40-21-317 46 90
Serbia	(011)-240 43 51	+381-11-240 43 51
Slovakia	(02)-492 05 963	+421-2-49 20 59 63
Slovenia	(01)-530 53 10	+386-1-530 53 10
Spain	900-101 576	+34-91-594 93 40
Sweden	020-88 87 77	+46-771-88 87 77 (+46 8 5179 2873)

Switzerland (+Liechtenstein)	0800-55 01 41	+41 58 827 60 86
Turkey	(216) 560 07 50	+90 216 560 07 50
Ukraine	044-494 29 52	+380-44-494 29 52
Hungary	(06-1)-345 17 47	+36-1-345 17 47

Table of contents

Warranty information	11	Rider's obligations	33
General warranty conditions	11	Rider's training.....	34
Infotainment	18	Apparel	34
Infotainment	18	Safety "Best Practices"	35
Bluetooth device pairing and management	19	Refuelling.....	37
Phone.....	25	Carrying the maximum load allowed	38
Music.....	29	Information about carrying capacity.....	38
General Information.....	31	Dangerous products - warnings	39
Acronyms and abbreviations used in the Manual.....	31	Vehicle identification number.....	41
Warning symbols used in the manual	31	Engine identification number	42
Intended use.....	32	Main components and devices	43
		Position on the vehicle	43
		Tank filler plug	44
		Seat lock.....	45
		Maintaining the battery charge.....	49
		Helmet cable	51
		Side stand	52
		Bluetooth control unit.....	54
		USB connection	56
		Adjusting windscreen height.....	57
		Front fork adjusters	60
		Front fork adjusters	62
		Rear shock absorber adjusters.....	64
		Rear shock absorber adjusters.....	66

Controls	68	Tool kit and accessories.....	98
Position of motorcycle controls	68	Instrument panel (Dashboard).....	99
Switchgears	69	Instrument panel.....	99
Light control	71	Warning lights.....	100
Keys.....	75	Main page items	104
Ignition switch and steering lock	76	Riding Mode	109
Restoring motorcycle operation via the PIN code	77	Engine rpm indication	112
Clutch lever	79	Info display	113
Throttle twistgrip	81	Lap.....	116
Front brake lever	82	Heated handgrips.....	119
Rear brake pedal.....	83	Setting menu.....	121
Gear change pedal.....	84	Setting menu - Riding Mode	123
Adjusting the position of the gearchange pedal and rear brake pedal.....	85	Setting menu - Riding Mode - Engine.....	125
Riding the motorcycle	86	Setting menu - Riding Mode - DTC	126
Running-in recommendations.....	86	Setting menu - Riding Mode - ABS.....	131
Pre-ride checks.....	87	Setting menu - Riding Mode - DWC	136
Engine start/stop	89	Setting menu - Riding Mode - DQS	141
Moving off	92	Setting menu - Riding Mode - Default.....	143
Braking	93	Setting menu - Fuel indicator.....	144
Stopping the motorcycle.....	94	Setting menu - DRL.....	145
Refuelling.....	95	Setting menu - Backlight.....	146
Parking.....	97	Setting menu - PIN Code.....	147
		Setting menu - Date and time.....	152
		Setting menu - Service.....	155

Setting menu - Lap	158	Scheduled maintenance chart.....	203
Setting menu - Tyre calibration.....	161	Scheduled maintenance chart: operations to be carried out by the dealer	203
Setting menu - Turn indicators.....	164	Scheduled maintenance chart: operations to be carried out by the customer	208
Setting menu - Measurement units	166		
Setting menu - Info.....	172		
Warning displaying	173		
Error warnings.....	176		
Main use and maintenance operations	178	Technical data	209
Checking coolant level and topping up, if necessary	178	Weights	209
Check clutch and brake fluid	179	Dimensions	210
Checking brake pads for wear	181	Fuel, lubricants and other fluids.....	211
Charging the battery.....	182	Engine.....	214
Checking drive chain tension	183	Timing system.....	215
Lubricating the drive chain	185	Performance data.....	216
Aligning the headlight.....	190	Spark plugs	216
Adjusting the rear-view mirrors.....	192	Fuel system.....	216
Tyres.....	194	Brakes	216
Check engine oil level	196	Transmission	217
Cleaning the motorcycle	198	Frame	218
Storing the motorcycle	200	Wheels	218
Important notes.....	201	Tyres.....	218
Vehicle transport	202	Suspension.....	219
		Exhaust system.....	219
		Available colours.....	219
		Electric system	221

Open source software 226

Information about open source software . 226

Declarations of conformity 227

Declarations of conformity 227

Warranty information

General warranty conditions

1. Warranty content

1.1. Ducati Motor Holding S.p.A. - A Sole partner company- a Company of the Audi Group, with headquarters in via Cavalieri Ducati no. 3, 40132, Bologna, Italy (hereafter "Ducati") - guarantees anywhere in the world where its official service network is present (list available at www.ducati.com) that all of its new motorcycles, manufactured for road use, for a period of twenty-four (24) months with no mileage/km limitation from the delivery date of the motorcycle to the first owner, shall be free of defects in workmanship as ascertained and recognised by Ducati.

1.2. In such cases, the Customer has the right to the repair or replacement of defective parts, free of charge.

1.3. The defective parts replaced under warranty become the property of Ducati.

1.4. The new parts replaced under warranty or repaired are covered by warranty for the remaining outstanding warranty period of the motorcycle.

1.5. Also, through a specific insurance policy, Ducati offers the Customer additional roadside and health assistance services in the Countries listed in the "Owner's manual", according to the specific terms and procedures reported therein.

1.6. The present general warranty conditions (hereafter "Warranty Conditions") do not in any way compromise the unalienable rights granted to individuals falling under the definition of "consumer" under the law of their respective countries. These warranty conditions are without prejudice to national provisions transposing and implementing Directive 99/44/EC in force in EU countries (in Italy, Legislative Decree no. 206 of 6 September 2005 - Consumer Code). In the event any one provision of these Warranty Conditions should conflict with mandatory law in force in the country of residence or domicile of the "consumer", such provision shall be treated as null and void.

2. Exclusions

2.1. This warranty offered by Ducati is not applicable to:

- a) to the Motorcycle that has not fully complied with the scheduled maintenance plan provided for in the Owner's Manual;
- b) to the Motorcycle with incorrect maintenance or repair operations carried out by parties other than the Ducati Authorised Dealers and/or Service Centres;
- c) to faults due to neglect of the Motorcycle;
- d) to faults concerning parts subject to wear and tear during normal operation of the Motorcycle (such as: tyres, filters, bulbs, final drive, belts, flexible controls, spark plugs, brake and clutch parts subject to friction, such as brake plates and pads, etc.);
- e) to aesthetic defects in painted or chrome-plated surfaces, such as oxidation of the Motorcycle and/or components thereof, natural discolouring, etc.;
- f) to faults involving Motorcycle battery if not properly kept charged with a Ducati charge maintainer;
- g) if the Motorcycle is used in sporting competitions of any kind or for damage resulting from improper use of the Motorcycle, on the track or on the road;
- h) to the Motorcycle to which modifications not approved by the manufacturer have been made, or that has been tampered with in any way and/or tuned in order to alter its performance, or with odometer tampered with;
- i) to the Motorcycle used in commercial or rental services or otherwise used for professional use;
- j) to the Motorcycle fitted with non-original Ducati spare parts or accessories or not authorised by Ducati;
- k) to the use of lubricants with specifications that do not comply with Ducati's requirements for the Motorcycle in question;
- l) to failure to comply with the prescriptions for the use of the Motorcycle and its equipment as indicated in the Owner's Manual;
- m) to modifications to the Motorcycle made by the Customer and / or third parties without the express approval of Ducati;
- n) to the Customer's failure to adhere to any recall and/or update campaigns planned by Ducati on the Motorcycle.

3. Responsibilities of the Customer

3.1. To activate this warranty and maintain its validity, the Customer is required to:

- a) notify one of the Ducati Authorised Dealers and/or Workshops (list available at www.ducati.com) of any defects of the motorcycle within two (2) months after Customer discovered said defects.
- b) keep adequate documentation of any maintenance and/or repair work carried out on the vehicle (receipts/invoices with details of the activities carried out and the parts used). You can consult the history of the ordinary maintenance of your motorcycle on the website www.ducati.com in the MyDucati section or on the MyDucati app.

3.2. In order to maintain the validity of the warranty in the event of a change of motorcycle ownership, the new owner must promptly notify Ducati of the change of ownership of the motorcycle, by communicating it on the website www.ducati.com in the MyDucati section or at the Ducati Authorised Dealers and/or Workshops.

3.3. If the provisions of points 3.1. and 3.2 are not observed, this warranty offered by Ducati will not

longer be in effect and the Customer rights to warranty performance will become null and void.

4. Limitations of liability

4.1. Without prejudice to the national regulations applicable to the “consumer” and relating provisions on manufacturer liability, Ducati shall not be held liable in case of damage to people and/or property caused by the motorcycle or while using the same.

4.2. Any defects or delays in the repairs or replacements relating to the motorcycle caused by Ducati Authorised Dealers and/or Workshops shall not give the buyer the right to claim damages of any kind from Ducati, nor to extend the warranty per the present Warranty Conditions, without prejudice to the Customer’s rights and actions with respect to the Ducati Authorised Dealer and/or Workshop that may be negligent/defaulting.

4.3. This warranty, under the terms specified here, constitutes the sole warranty offered by Ducati.

4.4. Ducati reserves the right to make changes and improvements to any model of its motorcycles, without the obligation to make said changes to motorcycles already sold.

4.5. These Warranty Conditions also extend to subsequent owners of the Ducati motorcycle,

provided that the provisions under art. 3 above are complied with.

4.6. Except as for the “consumer”, or as otherwise provided by a mandatory regulation in force in the country of the Customer, the Court of Bologna (Italy) shall have sole jurisdiction over any controversies that may arise in connection with these Warranty Conditions.

4.7. These Warranty Conditions are governed by Italian law.

5. Additional warranty and warranty extensions

5.1 Additional warranties may be provided or purchased depending on the product and the country (e.g. 4|Ever Multistrada, Factory Ever Red and Ever Red). For further details please refer to the Warranty Contract delivered by your Dealer when handing over your new motorcycle to the first owner or on the website www.ducati.com in the MyDucati section or on the MyDucati app.

6. Scheduled maintenance plan and pre-delivery

6.1. The pre-delivery operations are carried out by the seller.

6.2. Ducati has defined the scheduled maintenance plan included in the “Owner’s Manual” to keep their motorcycles at the best possible levels of efficiency, performance and safety.

6.3. Exact observance of the coupons, under the terms set forth herein, is a necessary condition to ensure the maintenance of the vehicle in correct usage status and the validity of this warranty. The following compulsory coupons must be carried out and paid for:

- first coupon: within six (6) months of delivery of the motorcycle to the Customer, or within the first 1000 km/600 miles travelled;

- second coupon: upon reaching the mileage specified in the maintenance schedule and in any case within twelve (12) months from previous service coupon. Customer is solely liable for all costs related to coupons (labour and materials), including the one at 1,000 km /600 miles.

6.4. Every maintenance operation on the motorcycle must be carried out in compliance with Ducati's recommendations and procedures, without limitations, including those reported in the "Owner's Manual". Any defect/damage to the vehicle caused by improper or insufficient maintenance will preclude the applicability of the warranty.

6.5. In order to certify that the operations specified for each service coupon have been duly performed, the Dealer and/or Authorised Ducati Workshop shall place their stamp and/or and write the necessary notes and/or perform the digital recording on the Service Booklet and/or in the dedicated area of the website ducati.com; it is also necessary to preserve the receipts/invoices for the service coupons that detail the operations performed. This documentation may be verified by the Ducati

Technical Service for the purpose of providing the services set forth in these Warranty Conditions.

6.6 Ordinary maintenance will be digitally recorded by the Ducati Dealer and available in the MyDucati app or on the ducati.com website.

If you purchased your motorbike in Australia or New Zealand



Attention

A reference to 'you' is a reference to the Customer.

If you purchased your motorbike in Australia:

Our goods come with guarantees that cannot be excluded under the Australian Consumer Law. You are entitled to a replacement or refund for a major failure and compensation for any other reasonably foreseeable loss or damage. You are also entitled to have the goods repaired or replaced if the goods fail to be of acceptable quality and the failure does not amount to a major failure.

If you purchased your motorbike in New Zealand:

Our goods come with guarantees that cannot be excluded under the Consumer Guarantees Act 1993. You are entitled to a replacement or refund for a failure of substantial character and compensation for any other reasonably foreseeable loss or damage. You are also entitled to have the goods repaired or replaced if the goods fail to be of acceptable quality and the failure does not amount to a failure of substantial character.

The benefits given to you by the warranty set out in this Owner's manual are in addition to any other rights and remedies you have under a law in relation to the motorcycle. If any provision of the general warranty conditions set out in this booklet should exclude or limit any rights under the Australian Consumer Law or the Consumer Guarantees Act 1993 (National Law), such provision is null and void. In circumstances where your rights under the National Law are greater than your rights under the Warranty, Ducati will honour your rights under the National Law.

To make a claim under the Warranty you must notify one of the Ducati Authorised Dealers and/or Workshops listed in the "Dealer Locator" (available at www.ducati.com) of any defects of the motorcycle within two (2) months of becoming aware of the defect. If you have any questions, you may contact Ducati ANZ Pty Ltd ACN 636 589 430 at Level 6, 895 South Dowling Street, Zetland NSW 2017 or by email at contact@ducati.com or by phone on 1300 11 26 06 (AU) / 0800 382 284 (NZ).

You must bear the expense of claiming under the Warranty.

Infotainment

Infotainment

The Supersport's infotainment system allows devices such as smartphones, rider and passenger helmet intercoms and satellite navigator to be connected via Bluetooth, allowing incoming and outgoing phone calls to be managed and music on the smartphone to be played.

- For pairing and managing Bluetooth devices, see page 19.
- For managing phone calls, see page 25.
- For managing the music player see page 29.

Bluetooth device pairing and management

This function allows the user to manage any paired Bluetooth devices and add more.

- Use buttons (1) and (2) from the Interactive Menu to select the “Setting menu” item and press ENTER (3).
- Select the “Bluetooth” item and press ENTER (3).

“Pairing” and “Paired devices” are displayed:

- “Pairing” allows pairing a new Bluetooth device.
- “Paired devices” allows viewing and erasing paired devices.

Use buttons (1) and (2) to scroll and select the desired item. Press ENTER (3) to confirm.

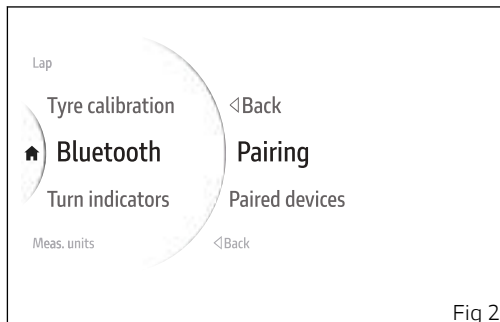
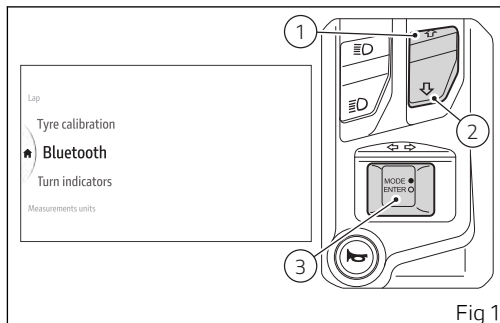

Pairing

This function allows pairing a new Bluetooth device. The instrument panel manages 4 types of Bluetooth devices and a maximum of 5 devices paired and/or connected: 2 smartphones, 1 rider earphone, 1 passenger earphone, 1 navigator. If you want to pair a new smartphone, earphone or navigator it is necessary to first disconnect one of the corresponding devices already paired (see section "Paired devices").

Note

Before pairing a new device, make sure that its Bluetooth connection is active and that it can be detected by other Bluetooth devices. Always refer to the provisions under the device instructions.

Note

During the pairing procedure user may be required to confirm it directly on the device (e.g. smartphone). Refer to the device messages.

- Use buttons (1) and (2) from the Interactive Menu to select the "Setting menu" item and press ENTER (3).

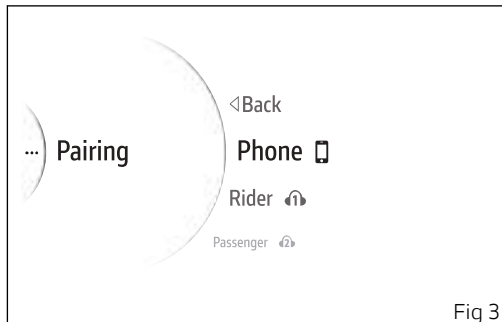

Fig 3

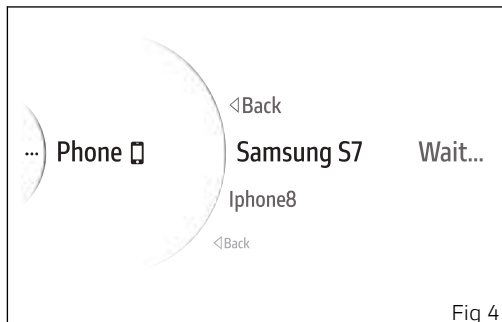

Fig 4

- Select the "Bluetooth" item and press ENTER (3).
- Select the "Pairing" item and press ENTER (3) (Fig 2).

The list of the 4 types of devices that can be managed from the instrument panel (Fig 3) is displayed. Select type of device to be paired and press ENTER button.

With buttons (1) and (2) select the type of device you wish to pair. Press ENTER (3) to confirm and start the device search.

The instrument panel starts searching for nearby Bluetooth devices, and displays the message "Wait..." followed by a list of detected devices (Fig 4). As soon as the search stage is over, system gives out a list of all detected devices.

Use the buttons (1) and (2) to select the required device and press ENTER button (3).

The display shows the message "Pairing..." on the right, while waiting validation by the Bluetooth device.

If the pairing of the device has been successful, the message "Paired" is displayed on the right for a few seconds and then the instrument panel returns to

the previous menu. If not, the message "Pairing Error" is displayed and user is allowed to repeat the pairing procedure.

Paired devices

This function allows viewing and erasing paired Bluetooth devices.

Maximum of 2 smartphones, 1 rider earphone, 1 passenger earphone, 1 navigator can be paired up.

- Use buttons (1) and (2) from the Interactive Menu to select the "Setting menu" item and press ENTER (3).
- Select the "Bluetooth" item and press ENTER (3).
- Select the "Paired devices" item and press ENTER (3) (Fig 2).

The paired devices are listed. Press buttons (1) and (2) to select the desired device and press ENTER (3). The message "Delete?" is shown on the right. (Fig 6) Press ENTER (3) to delete the selected device from the list: the message "Wait..." is displayed for a few seconds and then the list of paired devices is updated.

Note

If there are no paired devices, the message No Device is displayed.

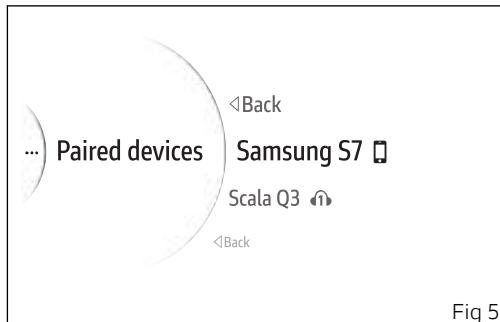

Fig 5

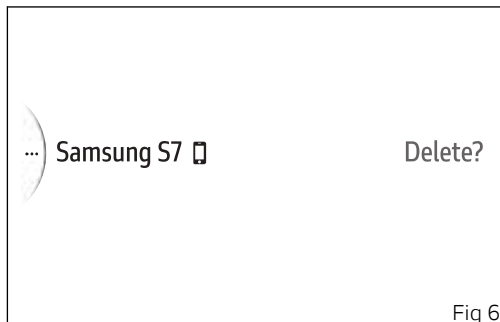

Fig 6



Attention

Smartphone and Bluetooth Headset device manufacturers may incorporate certain changes within the standard protocols over the course of the lifecycle of the device (Smartphones and Earphones).



Attention

These changes are outside the control of Ducati and may result in Smartphone and Bluetooth Headset devices functionality becoming impaired (sharing Music, multimedia player, etc.) and may equally affect some types of Smartphones (depending on supported Bluetooth profiles). This is why Ducati cannot guarantee multimedia player proper operation for:

- 1) the entire range of headphones and Smartphones available on the market;
- 2) Smartphones that do not support the required Bluetooth profiles.

Check that your Smartphone supports the following profiles:

- MAP profile: for a correct display of SMS and MMS notifications;

- PBAP profile: for a correct display of the Smartphone contact list.

Paired Bluetooth device icons

Once paired, Bluetooth devices are displayed as follows:

- 1) smartphone connected;
- 2) rider helmet intercom connected;
- 3) passenger helmet intercom connected;
- 4) rider helmet intercom connected and passenger helmet intercom associated;
- 5) passenger helmet intercom connected and rider helmet intercom associated;
- 6) rider and passenger helmet intercom connected;
- 7) satellite navigator connected.

Icons are black in the "day" mode or white in the "night" mode when the corresponding device is connected via Bluetooth. They are grey if the corresponding device is paired but not connected. To change the "day" or "night" display mode, refer to the chapter "Setting menu - Backlight" (page 146). If a smartphone is connected to the instrument panel, the system allows managing the music player, the list of the last calls and receiving or making phone calls. Refer to the chapters "Phone" (page 29) and "Music" (page 29).

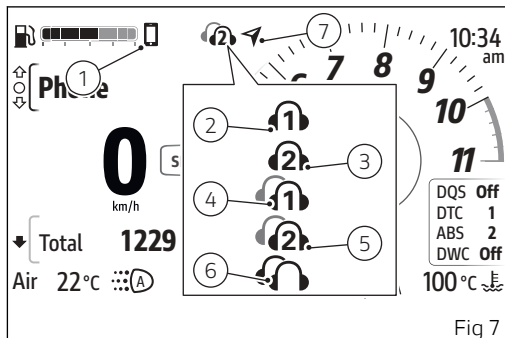

Fig 7

Phone

This function is available in the Interactive Menu and displays the list of the last missed, made or received calls and can only be selected if a smartphone has been connected via Bluetooth.

For the Bluetooth pairing procedure, refer to subsection "Bluetooth device pairing and management" (page 19).

- Select the Interactive Menu (A, Fig 8) by pressing and holding button (1) pressed for a long time.
- Use buttons (1) and (2) to select item "Phone" (B, Fig 8) and press the ENTER button (3).

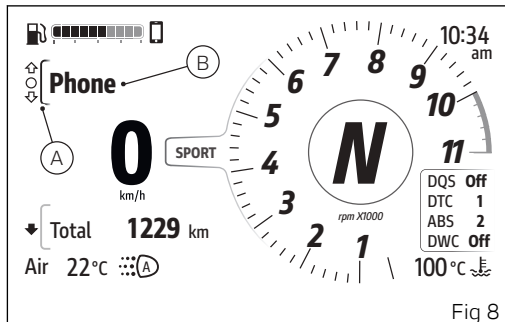

Fig 8

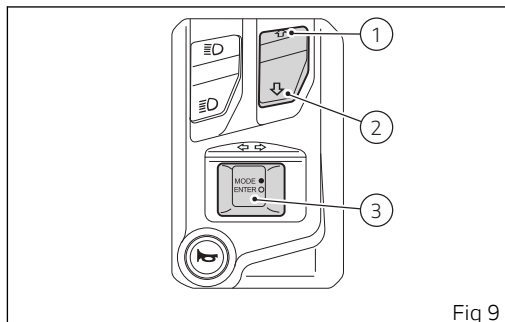

Fig 9

The relevant window (C, Fig 10) is shown listing the last 7 calls made, received or missed. If a number or contact is present several times among the last calls, this is displayed only once.

Use buttons (1) and (2) to scroll through the calls in the list. Press ENTER (3) to make a call to the number or contact selected in the list.

To close the window, press and hold button (1) for a long time.

Incoming call

When you receive a call, a window is shown with the name or number of the caller as well as the items "Accept" and "Decline" (D, Fig 11).

In this case, shortly press the ENTER button (3) to select the "Accept" or "Decline" item, press the ENTER button (3) for a long time to perform the action of the selected item.

Call in progress

When a call is in progress, a window is shown with the name or number of the contact as well as the item "End call" (E, Fig 11). To end the call, press the ENTER button (3).

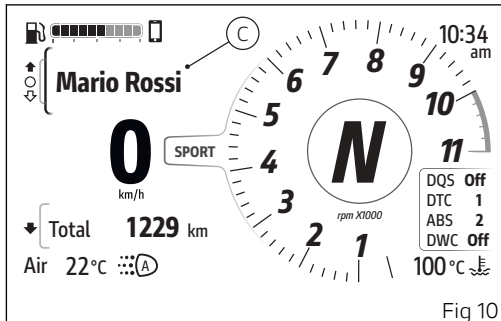

Fig 10

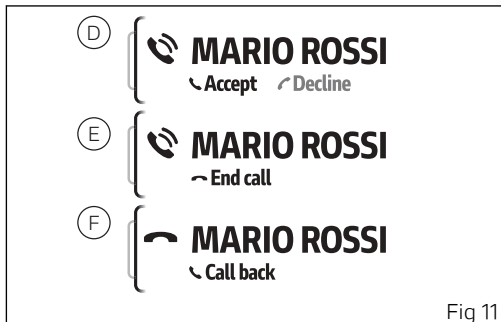

Fig 11

Call back

At the end of a call or after declining an incoming call, the window (F, Fig 11) will be displayed for 5 seconds with the name or number of the contact and "Call back": press ENTER button (3) to start the call.



Note

The music player will be paused during a call.

Missed call

In case of missed call, the display will show the symbol (G, Fig 12) for 60 seconds, flashing for the first 3 seconds.

Note

The number of missed calls is not displayed.

Message received

In case of received message, the display will show the symbol (H, Fig 13) for 60 seconds, flashing for the first 3 seconds.

Note

The number of received messages or e-mails is not displayed.

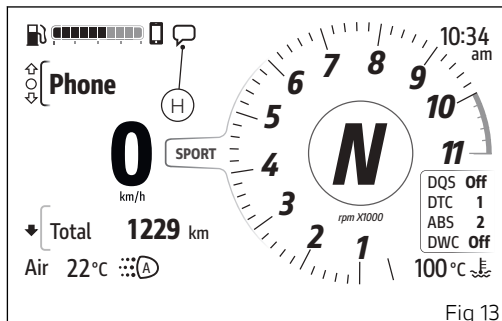
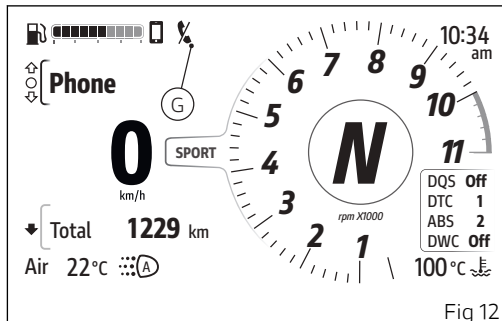

Music

This function is available in the Interactive Menu and allows activating, deactivating and managing the music player and can be selected only if a smartphone has been connected via Bluetooth.

For the Bluetooth pairing procedure, refer to sub-section "Bluetooth device pairing and management" (page 19).

- Select the Interactive Menu (A, Fig 14) by pressing and holding button (1) pressed for a long time.
- Use buttons (1) and (2) to select item "Music" (B, Fig 14) and press the ENTER button (3).

Note

Music is played on the smartphone connected via Bluetooth. If the rider and passenger intercoms are also connected to the instrument panel the music is played through the intercoms.

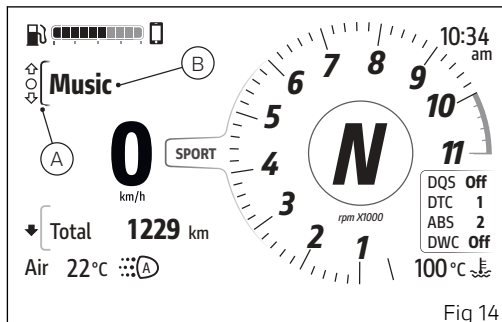

Fig 14

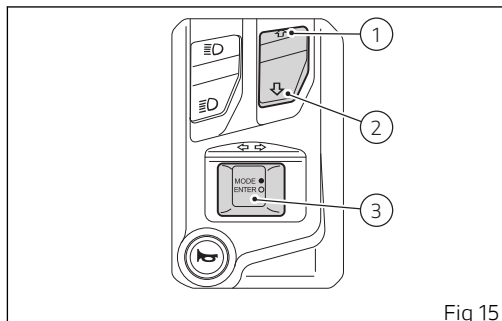

Fig 15

Window (C, Fig 16) will be displayed where the controls of the music player and the track currently playing are shown.

- By briefly pressing buttons (1) and (2) you can increase and decrease the volume respectively;
- by briefly pressing the ENTER button (3) it is possible to scroll and select the following controls, to activate the selected control press the ENTER button (3) for a long time:
 - ◀◀ previous track
 - ▶ play or || pause
 - ■ stop
 - ▶▶ next track

Pressing and holding button (1) for a long time while a track is playing will close the music player window but the track will not be stopped.

When ENTER button (3) is pressed with the stop control ■ selected, the music player window is closed and the current track is stopped.

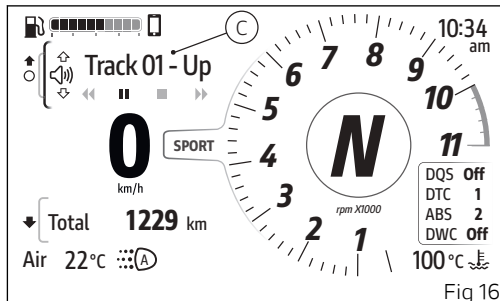

Fig 16

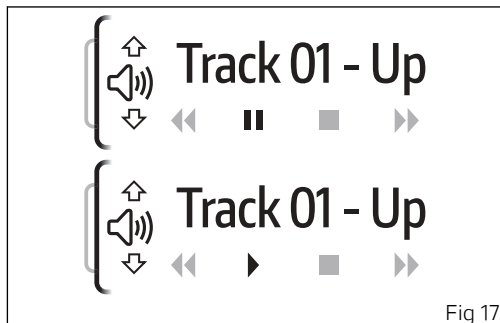

Fig 17

General Information

Acronyms and abbreviations used in the Manual

ABS	Anti-lock Braking System
DQS	Ducati Quick Shift
DRL	Daytime Running Lamp
DSB	Dashboard
DTC	Ducati Traction Control
DWC	Ducati Wheelie Control
GPS	Global Positioning System

Warning symbols used in the manual

Several kinds of warnings are used as an alert of the possible hazards for you or other persons such as:

- Safety labels on the motorcycle;
- Safety messages preceded by a warning symbol and either WARNING or IMPORTANT.



Attention

Failure to comply with these instructions may put you at risk, and could lead to severe injury or even death of the rider or other persons.



Important

Possibility of damaging the motorcycle and/or its components.



Note

Additional information about the current operation.

The terms RIGHT and LEFT are referred to the motorcycle viewed from the riding position.

Intended use

This motorcycle must be ridden on asphalt or on flat and even surfaces, only. This motorcycle may not be used for riding on dirt trails or for off-road riding.



Attention

Off-road riding may lead to loss of control and result in vehicle damage, personal injuries or even death.



Attention

This motorcycle may not be used to tow any trailers or with a side-car attached; this can lead to loss of control and result in an accident.

This motorcycle carries the rider and can carry a passenger provided that the supplied kit, which can be installed only at a Ducati Dealer or Authorised Service Centre, is fitted.



Attention

The total weight of the motorcycle in running order including rider, passenger, luggage and additional accessories should not exceed 410kg/904lb.



Important

Using the motorcycle under extreme conditions, such as very damp and muddy roads or dusty and dry environment, could cause above-average wear of components like the drive system, the brakes or the air filter. If the air filter is dirty, the engine could get damaged. Therefore, this might translate in required service or replacement of the wear parts earlier than specified in the scheduled maintenance chart.

Rider's obligations

All riders must hold a valid licence.

Attention

Riding without a licence is illegal and is prosecuted by law. Always make sure you have your licence with you when riding. Do not let inexperienced riders or persons without a valid licence use your motorcycle.

Do not ride under the influence of alcohol and/or drugs.

Attention

Riding under the influence of alcohol and/or drugs is illegal and is prosecuted by law.

Do not take prescription or other drugs before riding unless you have consulted your doctor about their side effects.

Attention

Some medications and drugs may cause drowsiness or other effects that slow down reaction time and the rider's ability to control the motorcycle, possibly leading to an accident.

Some states require vehicle insurance.

Attention

Check your state laws. Obtain insurance coverage and keep your insurance document secure with the other motorcycle documents.

To protect rider and passenger safety, some states mandate the use of a certified helmet.

Attention

Check your state laws. Riding without a helmet may be punishable by law.

Attention

Riders without helmets are more likely to suffer severe bodily injury or die if they are in an accident.

Attention

Check that your helmet complies with safety specifications, permits good vision, is the right size for your head, and carries a certification label indicating that it conforms to the standards in force in your state. Road traffic laws differ from state to state. Learn about traffic laws in your state before riding and always obey them.

Rider's training

Accidents are frequently due to inexperience.

Riding, manoeuvres and braking must be performed in a different way than on the other vehicles.

Attention

Untrained riders or a wrong use of the vehicle may lead to loss of control, serious injuries or even death.

Apparel

Riding gear is very important for safety. Unlike cars, a motorcycle offers no impact protection in an accident.

Proper riding gear includes helmet, eye protection, gloves, boots, back protector, long sleeve jacket and long trousers.

- The helmet must meet the requirements listed at "Rider's obligations"; if your helmet does not have a visor, use suitable eye wear;
- Use certified, five-finger gloves made from leather or abrasion-resistant material; with knuckle protectors and reinforcements on the fingers;
- Riding boots or shoes must have non-slip soles and offer ankle protection;

- The back protector must be certified and sized based on the physical constitution of the rider, according to the manufacturer's specifications;
- Jacket, trousers or riding suit must be certified, made from leather or abrasion-resistant material and have high-visibility colours and inserts. Select products with certified protectors.

Important

Never wear loose clothing, items or accessories that may become tangled in motorcycle parts.

Important

For your safety, always wear suitable protective gear, regardless of season and weather.

Important

Have your passenger wear proper protective clothing.

Safety "Best Practices"

These few simple operations are critical to people safety and to preserving the full performance of your motorcycle. Never forget to perform them before, while and after riding.

Important

Closely follow the indications provided at chapter "Riding the motorcycle" during the running-in period.

Failure to follow these instructions releases Ducati Motor Holding S.p.A. from any liability whatsoever for any engine damage or shorter engine life.

Attention

Before riding your motorcycle, become familiar with the controls you will need to use when riding.

Perform the checks recommended in this manual before each ride (see page 87).

Attention

Failure to carry out these checks before riding may lead to motorcycle damage and injury to rider and/or passenger.

Attention

Start the engine outdoors or in a well ventilated area. The engine should never be started or run indoors.

Exhaust gases are poisonous and may lead to loss of consciousness or even death within a short time. Use proper body position while riding and ensure your passenger does the same.

Important

Rider must hold the handlebar with both hands at ALL TIMES while riding.

Important

Both rider and passenger should keep their feet on the footpegs when the motorcycle is in motion.

Attention

The passenger should always hold on to the grab handles under the seat with both hands.

Important

Be very careful when tackling road junctions, or when riding in areas near exits from private grounds, car parks or on slip roads to access motorways.



Important

Be sure you are clearly visible and do not ride within the blind spot of vehicles ahead.



Important

ALWAYS signal your intention to turn or pull to the next lane in good time using the suitable turn indicators.



Important

Park your motorcycle where no one is likely to knock against it, and use the side stand. Never park on uneven or soft ground, or your motorcycle may fall over.



Important

Visually inspect the tyres at regular intervals for detecting cracks and cuts, especially on the side walls, bulges or large spots that are indicative of internal damage. Replace them if badly damaged. Remove any stones or other foreign bodies caught in the tread.



Attention

Engine, exhaust pipes and silencers stay hot long after the engine is switched off; pay particular attention not to touch the exhaust system with any body part and do not park the vehicle next to flammable material (wood, leaves etc.). Do not cover the motorbike with the canvas, when the engine and exhaust system are hot, to avoid damaging it.

Refuelling

Fuel label

Fuel identification label

Refuel outdoors with engine off.

Do not smoke or use open flames while refuelling. Be careful not to spill fuel on engine or exhaust pipe. Never completely fill the tank when refuelling. Fuel should never be touching the rim of filler recess. When refuelling, avoid breathing the fuel vapours and prevent fuel from reaching your eyes, skin or clothes.

Attention

The motorcycle is only compatible with fuel having a maximum content of ethanol of 10% (E10). Using fuel with ethanol content over 10% is forbidden. Using it could result in severe damage of the engine and motorcycle components. Using fuel with ethanol content over 10% will make the warranty null and void.

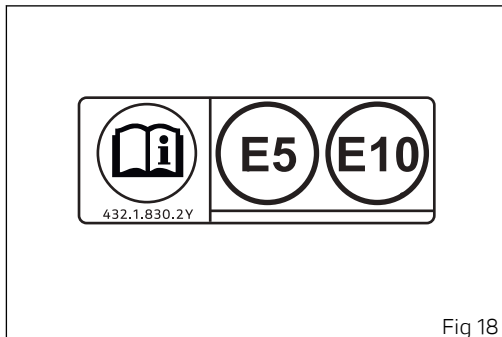

Fig 18

Attention

In case of indisposition caused by breathing fuel vapours for a long time, stay in the open air and contact your doctor. In case of contact with eyes, thoroughly flush with water; in case of contact with skin, immediately clean with water and soap.

Attention

Fuel is highly flammable, in case of accidental spillage of fuel on your clothes it is necessary to change into clean clothes.

Carrying the maximum load allowed

Your motorcycle is designed for long-distance riding, carrying the maximum load allowed in full safety. Even weight distribution is critical to preserving these safety features and avoiding trouble when performing sudden manoeuvres or riding on bumpy roads.

Attention

Do not exceed the total permitted weight for the motorcycle and pay attention to information provided below regarding load capacity.

Information about carrying capacity

Important

Arrange your luggage or heavy accessories in the lowest possible position and close to motorcycle centre.

Important

Never fix bulky or heavy objects to the handlebar or to the front mudguard as this would affect stability and cause danger.

Important

Be sure to secure the luggage to the supports provided on the motorcycle as firmly as possible. Improperly secured luggage may affect stability.

Important

Do not insert any objects you may need to carry into the gaps of the frame as these may foul moving parts.

Attention

Make sure the tyres are inflated to the proper pressure and that they are in good condition.

Refer to the paragraphs “Tyres” in the “Main use and maintenance operations” section and “Tyres” in the “Technical specifications” section.

Dangerous products - warnings

Used engine oil

Attention

Prolonged or repeated contact with used engine oil may cause skin cancer. If working with engine oil on a daily basis, we recommend washing your hands thoroughly with soap immediately afterwards. Keep away from children.

Brake dust

Never clean the brake assembly using compressed air or a dry brush.

Brake fluid

Attention

Spilling brake fluid onto plastic, rubber or painted parts of the motorcycle may cause damages. Protect these parts with a clean shop cloth before proceeding to service the system. Keep away from children.

Attention

The fluid used in the brake system is corrosive. In the event of accidental contact with eyes or skin, wash the affected area with abundant running water.

Coolant

Engine coolant contains ethylene glycol, which may ignite under particular conditions, producing invisible flames. Although the flames from burning ethylene glycol are not visible, they are still capable of causing severe burns.

Attention

Take care not to spill engine coolant on the exhaust system or engine parts.

These parts may be hot and ignite the coolant, which will subsequently burn with invisible flames.

Coolant (ethylene glycol) is irritant and poisonous when ingested. Keep away from children. Never remove the radiator cap when the engine is hot. The coolant is under pressure and will cause severe burns.

The cooling fan operates automatically: keep hands well clear and make sure your clothing does not snag on the fan.

Battery



Attention

The battery gives off explosive gases; never cause sparks or allow naked flames and cigarettes near the battery. When charging the battery, ensure that the working area is properly ventilated.

Vehicle identification number



Note

These numbers identify the motorcycle model and should always be indicated when ordering spare parts.

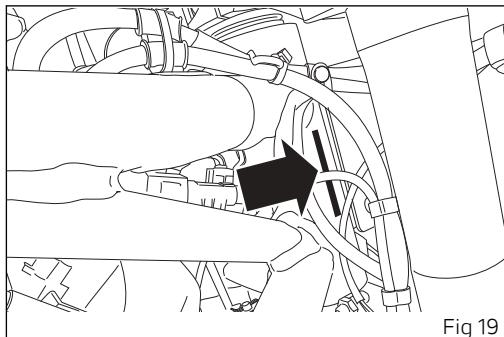
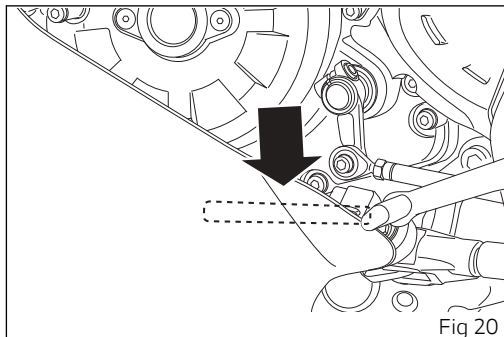

Fig 19

Engine identification number

Note

These numbers identify the motorcycle model and should always be indicated when ordering spare parts.



Main components and devices

Position on the vehicle

- 1) Tank filler plug.
- 2) Seat lock.
- 3) Helmet cable fastening pin.
- 4) Side stand.
- 5) Rear-view mirrors.
- 6) USB connection.
- 7) Front fork adjusters.
- 8) Rear shock absorber adjusters.
- 9) Catalytic converter.
- 10) Exhaust silencer.
- 11) Windscreen.

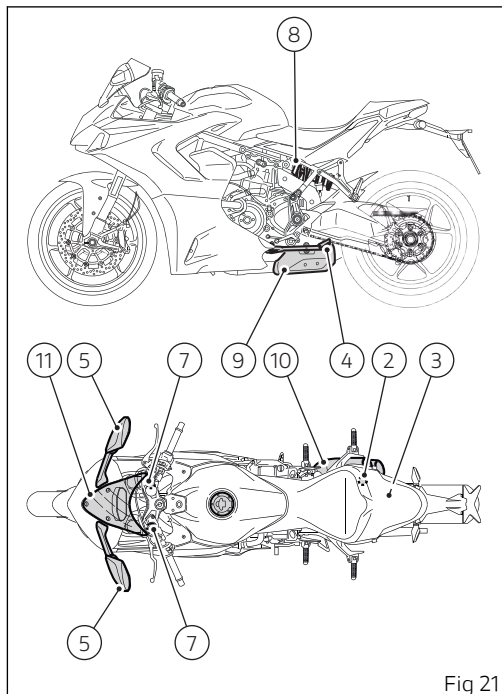

Fig 21

Tank filler plug

OPENING

Lift flap (1) and insert the key in the lock. Turn the key clockwise by 1/4 of a turn to release the lock.

CLOSING

Close the plug with key inserted and press to fit in place. Turn the key counter clockwise to the original position and remove it. Close flap (1).



Note

Plug can only be closed when key is inserted.



Attention

After refuelling, always make sure that the plug is perfectly in place and closed.

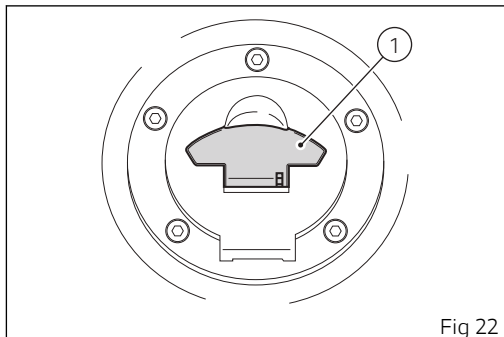

Seat lock

Removing the seat

Insert the key in lock (1), turn clockwise while pressing down at the latch (3) to help release the pin. Slide the seat (2) to the rear after removing the front retaining tabs (A) from the tank support bracket (B).

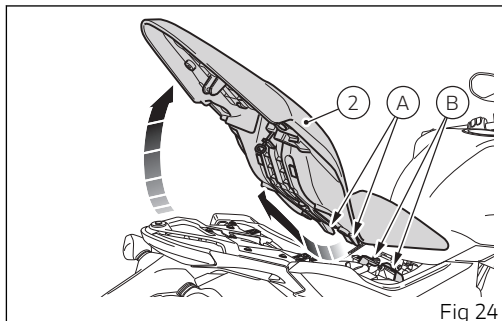
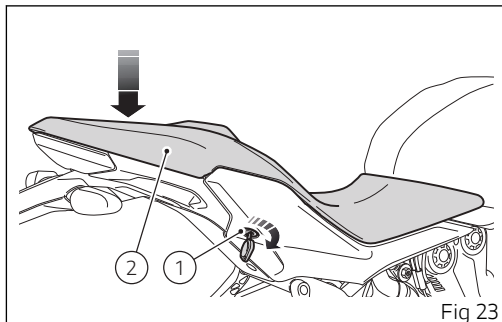

After removing the seat, you can reach the battery maintainer connector (C).
To use it, remove the cover and connect the connector (C) to maintainer (4), as described in chapter "Maintaining the battery charge".

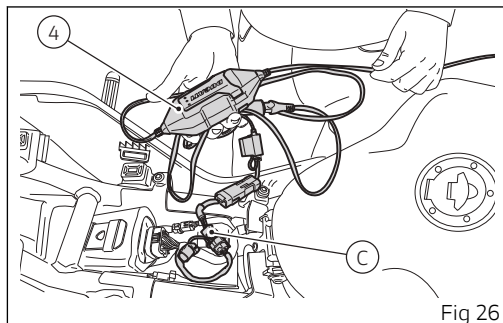
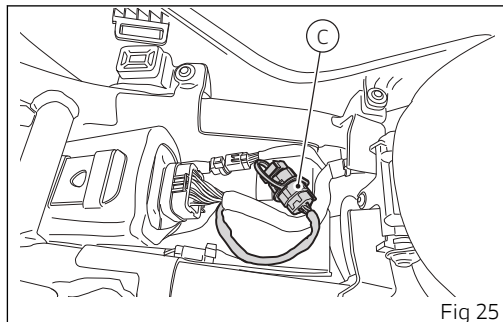

Refitting the seat

Make sure that all elements are correctly positioned and fastened to the compartment under the seat (2). Insert the retaining tabs (A), at the front end of the seat, into the tank support bracket (B) fixed to the rear subframe.

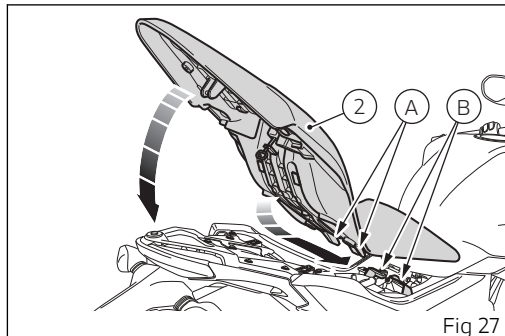
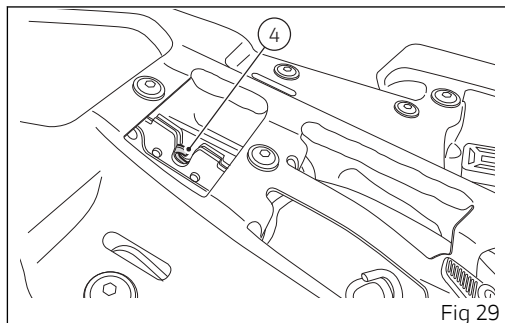
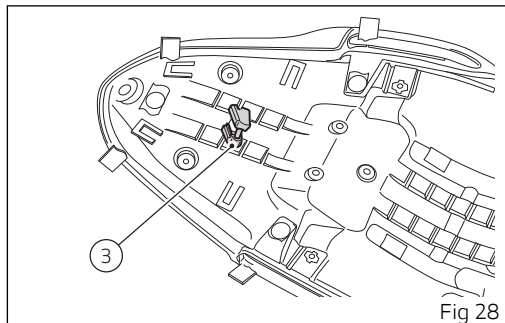

Fig 27

By keeping the rear part of the seat raised, insert the latch (3) into the lock (4), by pressing on the seat: push the seat rear end until you hear the lock (4) click into place.
Make sure the seat is safely secured to the frame and remove the key from the lock.



Maintaining the battery charge

Your motorcycle is equipped with a connector (1), under the seat, to which you can connect a special battery charger (2) (Battery charge maintenance kit part no. 69928471A (Europe), part no. 69928471AW (Japan), 69928471AX (Australia), 69928471AY (UK), 69928471AZ (USA), available from our sales network.

Note

The electric system of this model is designed so as to ensure there is a very low power drain when the motorcycle is OFF. Nevertheless, the battery features a certain self-discharge rate that is normal and depends on ambient conditions as well as on "non-use" time.

Important

If battery is not kept at a minimum charge level by a suitable battery charge maintainer, sulphation may occur and this is an irreversible phenomenon causing decreasing battery performance.

When the motorcycle is left unused (approximately for more than 30 days). We recommend owners to use the Ducati battery charge maintainer (Battery maintenance kit) since its electronics monitors the battery voltage and features a maximum charge

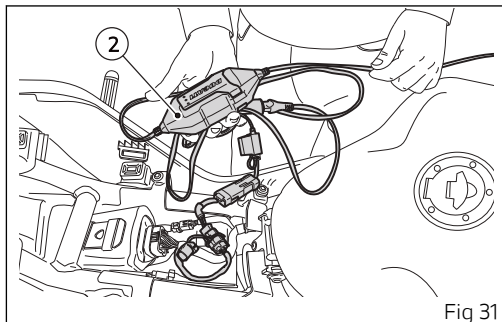
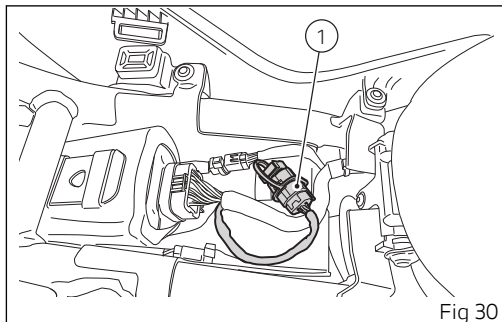

current of 1.5 Ah. Connect the battery maintainer to the diagnostic socket.



Note

Using charge maintainers not approved by Ducati could damage the electric system; motorcycle warranty does not cover the battery if damaged due to failure to comply with the above indications, since it is considered as wrong maintenance.

Helmet cable

The helmet cable (1) is inside the tool box, refer to "Tool kit and accessories". Route cable through helmet and engage cable end into pin (2). Leave the helmet hanging and refit the seat to hold it in place.



Attention

This device protects the helmet against theft when the motorcycle is parked. Do not leave the helmet attached when riding the motorcycle; it could interfere with your movements and cause loss of control of the motorcycle.

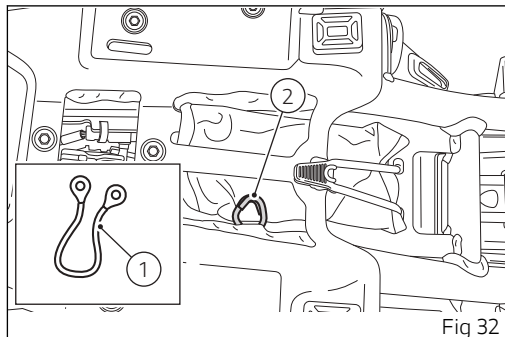

Side stand

Important

The position of the side stand is identified on the instrument panel by the warning light (A). When the warning light is on, the side stand is lowered (and the engine start is inhibited).

Attention

Before lowering the side stand, make sure that the bearing surface is hard and flat.

Do not park on soft or pebbled ground or on asphalt melt by the sun heat and similar or the motorcycle may fall over.

When parking downhill, always position the motorcycle with the rear wheel facing downhill. To pull down the side stand, hold the motorcycle handlebars with both hands and push down on the side stand (1) with your foot until it is fully extended. Tilt the motorcycle until the side stand is resting on the ground.

Attention

Do not sit on the motorcycle when it is supported on the side stand.

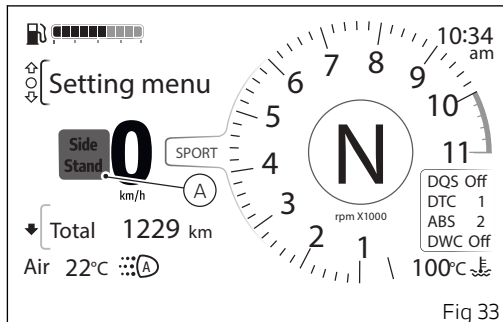

Fig 33

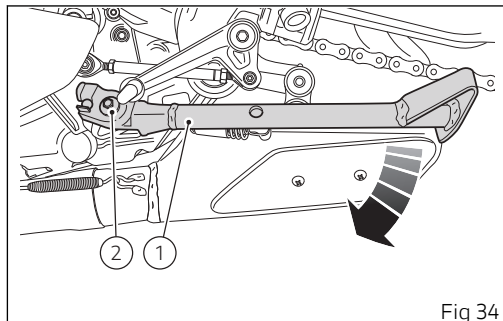

Fig 34

To move the side stand to its resting position (horizontal position), lean the motorcycle to the right while lifting the side stand (1) with your foot. To ensure trouble-free operation of the side stand joint, thoroughly clean it and then use SHELL Alvania R3 grease to lubricate all friction points.

Note

The engine can be started with the side stand down and the gearbox in neutral. If starting with a gear engaged, pull in the clutch lever (in this case the side stand must be up before engaging the gear).

Bluetooth control unit

The motorcycle can be equipped with a Bluetooth control unit that works as a hub between the various supported electronic devices relying on a Bluetooth communication interface.

The Bluetooth control unit can be purchased at a Ducati Dealer or Authorised Service Centre.

Attention

Smartphone and Bluetooth Headset device manufacturers may incorporate certain changes within the standard protocols over the course of the lifecycle of the device (Smartphones and Earphones).

Attention

These changes are outside the control of Ducati and may result in Bluetooth Headset devices functionality becoming impaired (sharing Music, multimedia player, etc.) and may equally affect some types of Smartphones (depending on supported Bluetooth profiles). This is why Ducati cannot guarantee multimedia player proper operation for:

- any earphones not coming with the "Ducati Kit part no. 981029498";
- any Smartphones not supporting the required Bluetooth profiles (even though paired to earphones coming with the "Ducati Kit part no. 981029498").

Attention

In case of interference or noise due to particular conditions of the external environment, the Ducati earphone kit part no. 981029498 also allows sharing the music being played directly from rider helmet to passenger helmet (for further details please refer to the manual of the earphones coming with the Ducati kit part no. 981029498).

 **Note**

The Ducati kit part no. 981029498 can be purchased separately at a Ducati Dealer or Authorised Service Centre.

 **Attention**

Ducati does not ensure a correct connection to the Ducati Multimedia System of Bluetooth navigators that are not provided in the following kits:

- Kit of Ducati Zumo satellite navigator 350
- Kit of Ducati Zumo satellite navigator 390
- Kit of Ducati Zumo satellite navigator 395

 **Note**

The Ducati kits mentioned above can be purchased separately at a Ducati Dealer or Authorised Service Centre.

Check that your Smartphone supports the following profiles:

- MAP profile: for a correct display of SMS and MMS notifications;
- PBAP profile: for a correct display of the Smartphone contact list.

USB connection

The motorcycle is provided with a 5 V USB connection. It is possible to connect electric loads up to 1A to the USB connection.

USB connection (1) is located under the seat, on the left side, and is protected by a flap: lift flap to use connection.

Important

When the engine is off and key set to ON, do not leave accessories connected to the USB socket for a long period of time as the motorcycle battery could run flat.

Attention

When not in use, ALWAYS keep USB socket closed with its cap.

Attention

NEVER use the USB socket if it is raining.

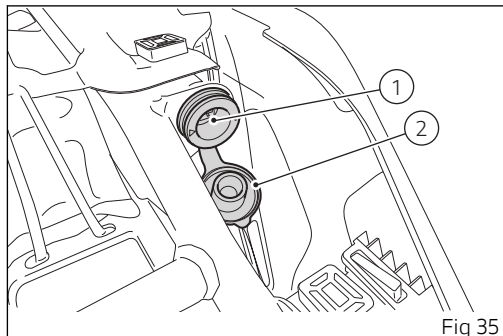

Fig 35

Adjusting windscreen height



Attention

Adjusting windscreen height while riding could cause an accident. Adjust the windscreen only with motorcycle at a standstill.

Windscreen (1) can be adjusted in two positions: high and low.

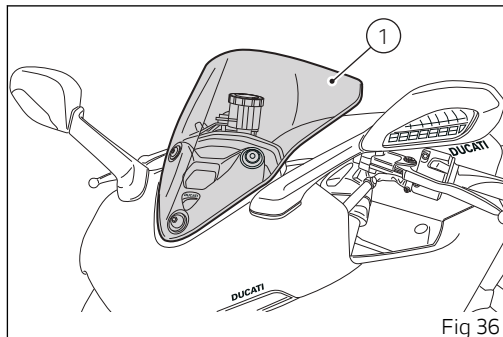

Fig 36

To move windscreen (1) from the low to the high position, grab it in the central area and pull it up, as shown in the figure, until hearing the "clicks" indicating the correct positioning of windscreen (1).

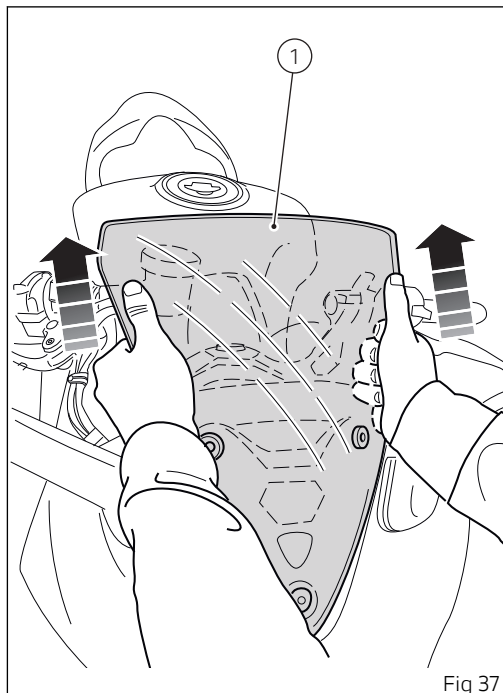

Fig 37

To move the windscreen (1) back to the low position, lower it with one hand, as shown in the figure.

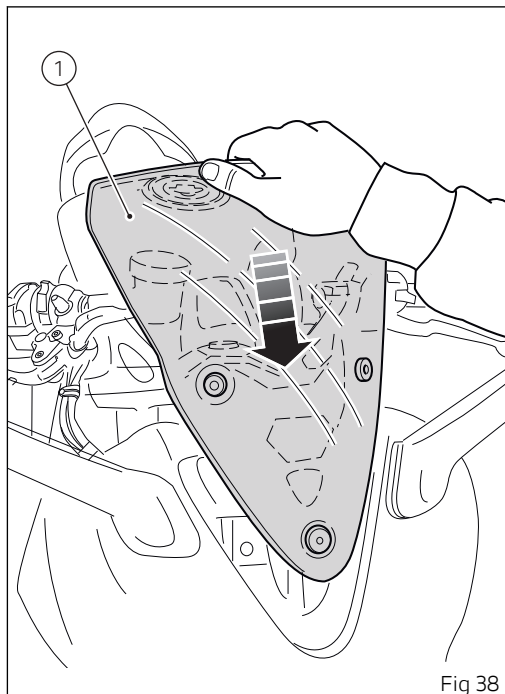

Fig 38

Front fork adjusters

The Marzocchi fork of the Supersport is fully adjustable in rebound and compression hydraulic damping and in spring preload.

It is possible to adjust the spring preload on both legs, the compression and rebound can only be adjusted on the LH and RH legs, respectively.

Adjustment is done by external screw adjusters:

In particular:

- 1) for rebound adjustment;
- 2) to adjust the preload of the inner springs;
- 3) to adjust the compression damping.

Position the motorcycle on its side stand so that it is stable.

Turn adjuster (1) at the top end of the RH fork leg with a suitable screwdriver to adjust rebound.

Turn adjuster (3) at the top end of the LH fork leg with a suitable screwdriver to adjust compression.

By turning adjuster screws (1) and (3) you will hear some clicks; each click corresponds to a damping setting.

The stiffest damping setting is obtained with the adjuster turned fully clockwise to the "0" position.

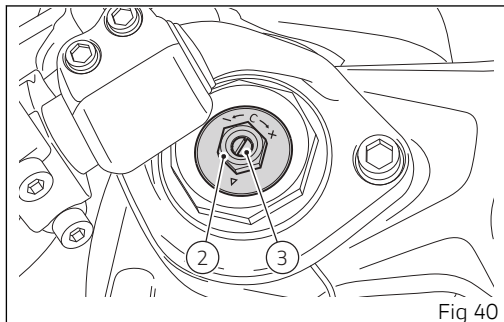
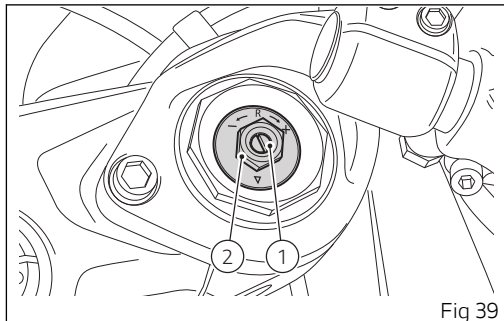

By turning counter clockwise starting from this position, count the clicks that will correspond to positions "1", "2" etc.

To change preload of the spring inside each fork leg, turn adjusters (2) with a hexagon wrench, completely anticlockwise, to obtain fully uncompressed position. From this position, adjust the spring preload by turning the adjuster (2) clockwise. Every turn corresponds to 1 mm (0.04 in) of spring preload.

STANDARD settings are as follows:

- compression: 3 turns (from fully closed);
- rebound: 3 turns (from fully closed);
- spring preload: 5 turns (from fully unloaded).



Attention

Adjust both fork leg spring preload to same settings.

Front fork adjusters

The Öhlins fork of the Supersport is fully adjustable in rebound and compression hydraulic damping and in spring preload.

It is possible to adjust the spring preload on both legs, the compression and rebound can only be adjusted on the LH and RH legs, respectively.

Adjustment is done by external screw adjusters:

In particular:

- 1) for rebound adjustment;
- 2) to adjust the preload of the inner springs;
- 3) to adjust the compression damping.

Position the motorcycle on its side stand so that it is stable.

Turn the adjuster (1) at the top end of the RH fork leg with a suitable screwdriver to adjust rebound damping.

Turn adjuster (3) at the top end of the LH fork leg with a screwdriver to adjust compression. By turning adjuster screws (1) and (3) you will hear some clicks; each click corresponds to a damping setting.

The stiffest damping setting is obtained with the adjuster screws (1) and (3) turned fully clockwise to the "0" position.

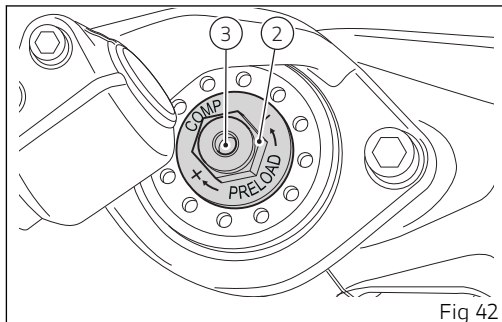
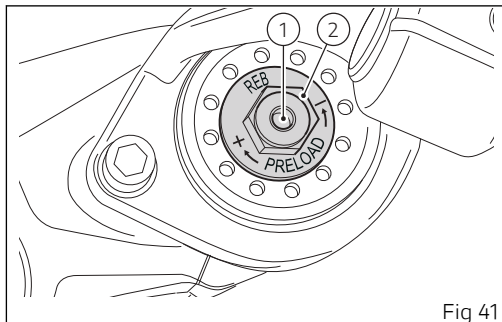

By turning counter clockwise starting from this position, count the clicks that will correspond to positions "1", "2" etc.

To change preload of the spring inside each fork leg, turn adjusters (2) with a hexagon wrench, completely anticlockwise, to obtain fully uncompressed position. From this position, adjust the spring preload by turning the adjuster (2) clockwise. Every turn corresponds to 1 mm (0.04 in) of spring preload.

STANDARD settings are as follows:

- compression: 16 clicks (from fully closed position);
- rebound: 6 clicks (from fully closed position);
- spring preload: 7 turns (7 mm) (0.27 in) (from fully unloaded).



Attention

Adjust both fork legs to same settings.

Rear shock absorber adjusters

Supersport

The rear shock absorber has external adjusters that enable you to adjust the setting to suit the load on the motorcycle.

The adjuster (1) located on the left side, on the upper connection holding the shock absorber to the engine, adjusts the damping during the rebound phase (return).

Turn adjuster (1) clockwise to stiffen the damping, or counter clockwise to soften it.

Ring nuts (2) and (3), located in the shock absorber lower side, adjust the external spring preload.

To adjust the spring preload, loosen the bottom ring nut (3). Screwing or unscrewing the top ring nut (2) will increase or decrease the preload.

Once the spring preload is set, tighten the bottom ring nut (3).

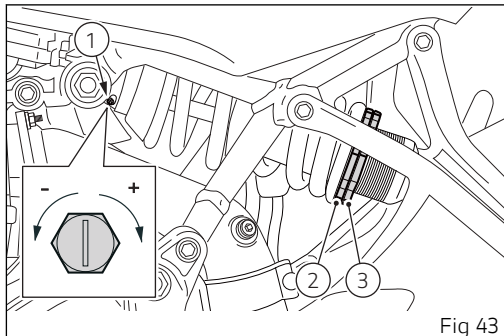

Fig 43

STANDARD setting from the fully closed position (clockwise):

- rebound: loosen adjuster (1) by 1+1/4 turns (from fully closed position);
- spring preload: 13 mm (0.51 in).



Attention

To turn the preload adjuster ring nut use a pin wrench. Pay attention to avoid hand injuries by hitting motorcycle parts in case the wrench tooth suddenly slips on the ring nut groove while moving it.



Attention

The shock absorber is filled with gas under pressure and may cause severe damage if taken apart by unskilled persons.

Rear shock absorber adjusters

Supersport S

The rear shock absorber has external adjusters that enable you to adjust the setting to suit the load on the motorcycle. Knob (1) located on the expansion reservoir adjusts the damping during the compression phase.

Knob (3) located on the upper connection holding the shock absorber to the engine, adjusts the damping during the rebound phase (return).

Turn knob (1) clockwise to stiffen the damping, or counter clockwise to soften it.

Turn knob (3) counter clockwise to stiffen the damping, or clockwise to soften it.

The two ring nuts (2), located in the shock absorber lower side, adjust the external spring preload.

To adjust the spring preload, loosen the bottom ring nut. Screwing or unscrewing the top ring nut will increase or decrease the preload.

Once the spring preload is set, tighten the bottom ring nut.

STANDARD setting from the fully closed position:

- rebound: loosen adjuster (3) by 14 clicks (from fully closed);

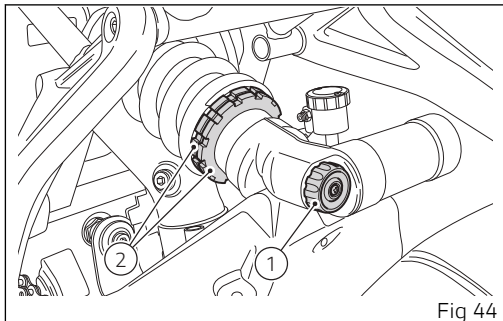

Fig 44

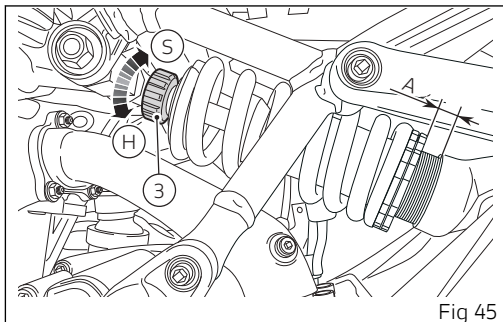

Fig 45

- compression: loosen adjuster (1) by 12 clicks (from fully closed);
- spring preload: position the ring nuts at a distance (A) from the endcap of 14 mm (0.55 in).



Attention

To turn the preload adjuster ring nut use a pin wrench. Pay attention to avoid hand injuries by hitting motorcycle parts in case the wrench tooth suddenly slips on the ring nut groove while moving it.



Attention

The shock absorber is filled with gas under pressure and may cause severe damage if taken apart by unskilled persons.

Controls

Position of motorcycle controls

Attention

This section shows the position and function of the controls used to ride the motorcycle. Be sure to read this information carefully before you use the controls.

- 1) Instrument panel.
- 2) Key-operated ignition switch and steering lock.
- 3) Left-hand switch.
- 4) Clutch lever.
- 5) Right-hand switch.
- 6) Throttle twistgrip.
- 7) Front brake lever.
- 8) Gear change pedal.
- 9) Rear brake pedal.

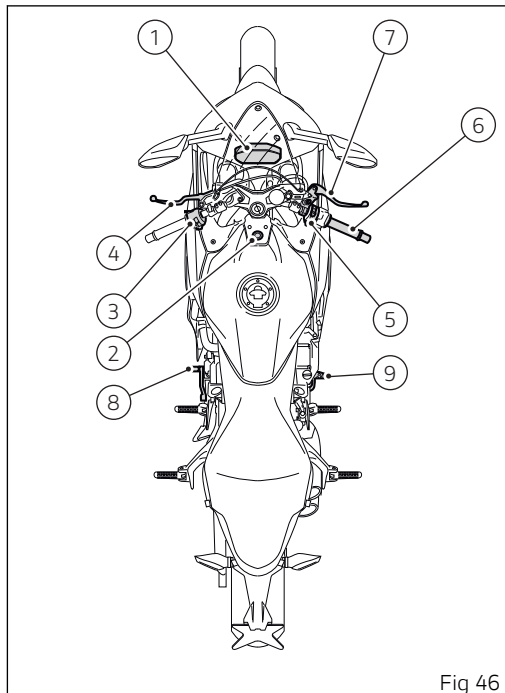

Fig 46

Switchgears

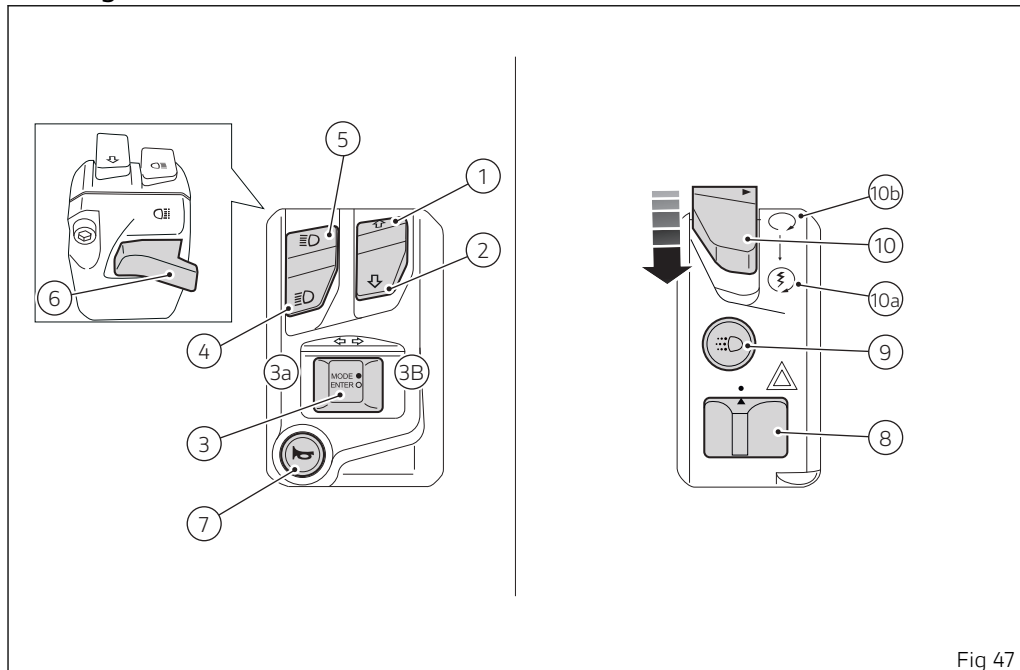













Fig 47

1		Control button up.
2		Control button down.
3	<p>MODE ● ENTER ○ </p>	<p>Riding Mode change button, ENTER function button and turn indicator three-position switch:</p> <ul style="list-style-type: none"> ● position (3a), left turn indicator; ● centre position, OFF; ● position (3b), right turn indicator.
4		Low beam.
5		High beam.
6		High-beam flasher and "Start/Stop Lap" function.
7		Horn.
8		Hazard lights (red).
9		DRL (if present).
10		2-position switch (red).
10a		Engine start, pushed down.
10b		Engine stop.

Light control

Low / High beam

By means of button (A) it is possible to switch from low beam to high beam and vice versa: position (B) for high beam, position (C) for low beam. To flash, press the button (D).

If engine is not started after turning the key to on, it is nevertheless possible to switch on the lights or flash.

If within 60 seconds from the manual switching on of the low or high beam the engine is not started, the lights are turned off.

To preserve the motorcycle battery, the headlight is automatically switched off when starting the engine and it is then switched on again when the engine has started.

DRL in "Auto" mode – only for version with DRL lights

If the DRL was set to "Auto" via the "DRL" function within "Setting menu" (page 145), the instrument panel automatically manages the DRL and the low beam according to detected ambient light:

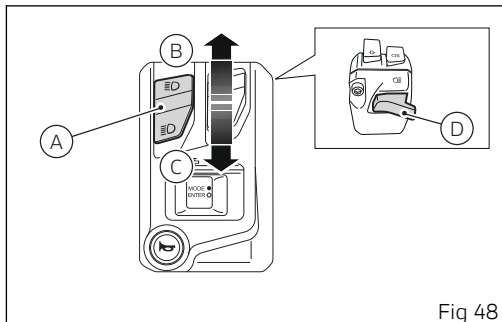

Fig 48

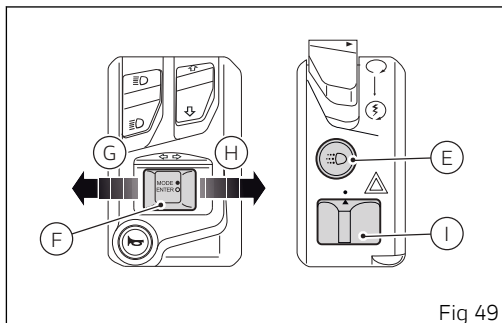

Fig 49

- if the instrument panel detects good light conditions (day) the DRL is turned on and the low beam is turned off;
- if the instrument panel detects poor light conditions (night) the DRL is turned off and the low beam is turned on.

When the DRL is set to "Auto" mode, the corresponding warning light will turn on. If the DRL was set to "Auto" mode, press button (E, Fig 49) to disable that mode and set manual light management. Press again button (E, Fig 49) to re-enable DRL but with control strategy set to "Manual".

In this case, upon next Key-On, DRL will be again set to "Auto" mode.

Attention

Using the DRL light in "Auto" mode in case of poor light conditions, especially in case of fog or clouds, could impair safety. In this case Ducati recommends to manually activate the low beam.

DRL in "Manual" mode – only for version with DRL lights

If the Daytime Running Lights are in this mode, as set through the "DRL" function within the "Setting menu" (page 145), DRL will not change status upon key-on.

To switch on or off the DRL lights, it is necessary to press button (E, Fig 49).

Attention

Using the DRL lights in poor light conditions (dark) could compromise the riding visibility and dazzle anyone coming on the opposite lane.

Note

Using the DRL lights during the day improves visibility compared to low beam.

Turn indicators

Using the "Turn indicators" function in the "Setting menu" (page 164), you can set the control of the turn indicators to automatic or manual mode.

To activate the left turn indicator, press button (F, Fig 49) in position (G, Fig 49); to activate the right turn indicator, press button in position (H, Fig 49).

To switch off the turn indicators, set the button (F, Fig 49) to its centre position.

Automatic switch-off:

The turn indicators switch off automatically after the turn, as calculated based on vehicle speed, lean angle and in general according to the analysis of vehicle dynamic conditions.

This means that automatic switch-off is triggered when vehicle speed exceeds 20 km/h (12.4 mph) after the turn indicator button was pressed.

Turn indicators also switch off automatically if they remained on for a long mileage (which can range between 200 and 2000 metres (656-6562 feet), depending on vehicle speed when the turn indicator button was pressed.

If the turn indicator switch is again operated, while turn indicator is still on, automatic switch-off feature is re-initialised.

Attention

The automatic deactivation systems are assist systems helping the rider control the turn indicators in the most comfortable and easy way. Such systems have been designed to work in most riding manoeuvres, nonetheless the rider must pay attention to the turn indicator operation (disabling or enabling them by hand if needed).

Hazard lights

To activate or deactivate the hazard lights, press button (I, Fig 49) only when the vehicle is in key-on condition.

When turning the vehicle key OFF with hazard lights active, they will remain active for 2 hours. After 2 hours, the hazard lights switch OFF automatically in order to save battery charge.



Note

When turning the vehicle key ON with hazard lights still active, they will remain active.



Note

If there is a sudden interruption in the battery while the function is active, the instrument panel will disable the function when the voltage is restored.



Note

The hazard lights have a higher priority than the normal operation of the individual turn indicators.

 **Note****Emergency braking**

In the event of heavy braking from a speed of more than 55 km/h the tail light flashes rapidly in order to warn the vehicles behind. When deceleration is reduced below a predefined threshold, the flashing is automatically deactivated.

Keys

The motorcycle comes with 2 keys.

They contain the "Immobilizer system code".

The supplied keys are those for the standard use, i.e. to:

- start the engine;
- open the fuel tank plug;
- open the seat lock.

Attention

Separate the keys and use only one of the two to ride the bike.

Duplicate keys

When a customer needs spare keys, he/she shall contact a Ducati authorised service centre and bring all keys he/she still has.

The Ducati authorised service centre will program all new and old keys.

The Ducati authorised service centre may ask to the customer to prove to be the motorcycle owner.

The codes of the keys missing during the programming procedure will be erased to ensure that any lost key can not start the engine.

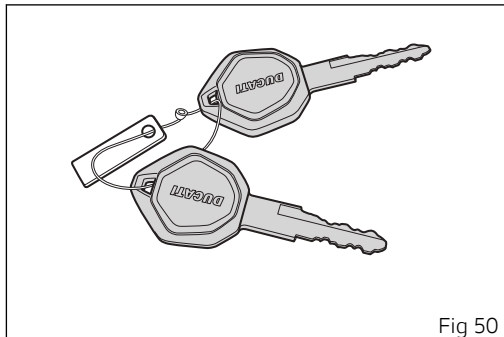

Fig 50

Note

If the motorcycle owner changes, it is necessary that the new owner is given all keys.

Ignition switch and steering lock

It is located in front of the fuel tank and has four positions:

- A) ON: enables lights and engine operation;
- B) OFF: disables lights and engine operation;
- C) LOCK: the steering is locked;

Note

To move the key to the last two positions, press it down before turning it. The key can be removed in positions (B), (C) and (D).

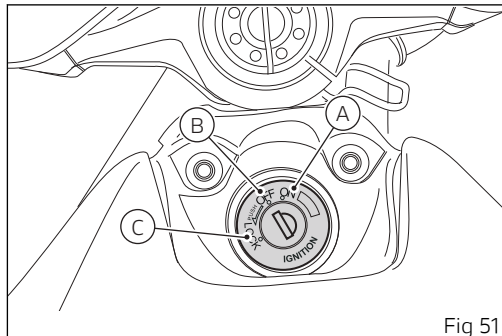

Fig 51

Restoring motorcycle operation via the PIN code

In case of key acknowledgement system or key malfunction, the instrument panel allows the user to enter his/her own PIN code to temporarily restore motorcycle operation.

If the PIN code has been activated via the "PIN Code" function in the "Setting menu" page 147, the instrument panel displays "Insert PIN" and next to it the spaces for the four digits of the PIN.

Entering the code:

- The 2 arrows above and below the digit indicate that the number can be changed from 0 to 9 using buttons (1) and (2).
- Press ENTER (3) to confirm and move on to the following digit.
- Repeat the procedure until entering all 4 digits.

Once the fourth digit is set, press ENTER (3) and the instrument panel behaviour will be as follows:

- if there is a problem during the PIN check, the instrument panel displays an error for 2 seconds and then passes to the main screen;
- if PIN code is not correct, the instrument panel displays "Wrong" for 2 seconds and then goes

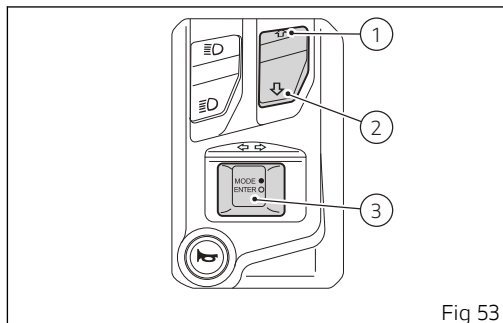
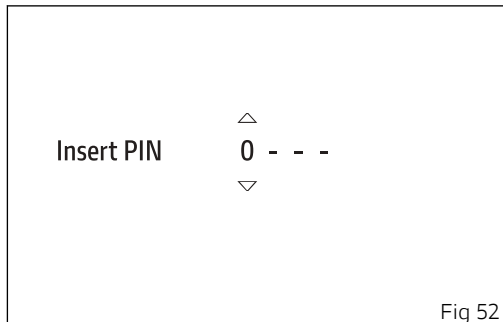

back to previous screen, to allow you to try again.

- if the PIN CODE is correct, the instrument panel shows "Correct" for 2 seconds, and then displays the standard screen.



Important

If this procedure is necessary in order to start the motorcycle, contact an Authorised Ducati Service Centre as soon as possible to fix the problem.

Clutch lever

Lever (1) disengages the clutch. When the clutch lever (1) is operated, drive from the engine to the gearbox and the drive wheel is disengaged. Using the clutch properly is essential to smooth riding, especially when moving OFF.

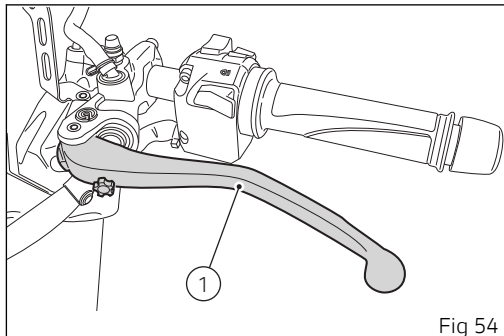

Fig 54

Clutch control free play adjustment

The brake lever has a dial adjuster (2) for adjusting the distance between lever and twistgrip on the handlebar.

Turn clockwise to increase lever distance from the handgrip.

Turn the adjuster counter clockwise to decrease lever distance.

The lever distance can be adjusted to a distance A= 6.4 mm (0.25 in).



Important

Using the clutch properly will avoid damage to transmission parts and spare the engine.

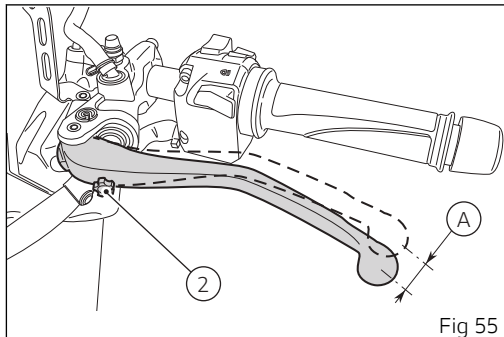

Throttle twistgrip

The twistgrip (1) on the right handlebar opens the throttles.

When released, it will spring back to the initial position (idling speed).

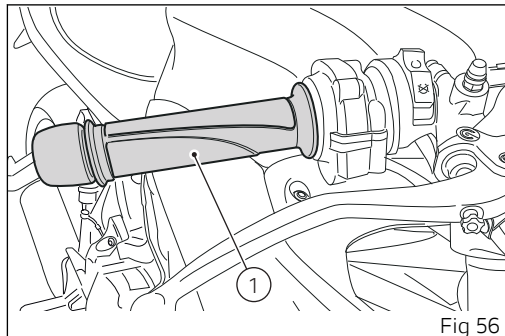

Fig 56

Front brake lever

Pull in the lever (1) towards the twistgrip to operate the front brake. The system is hydraulically operated and you just need to pull the lever gently.

The brake lever has a knob (2) for adjusting the distance (A) from the handgrip on the handlebar. The lever distance (1) can be adjusted in a space of $A = 10 \text{ mm}$ (0.39 in).

Turn the knob (2) clockwise to increase lever (1) distance from the twist grip. Turn the adjuster (2) anticlockwise to decrease lever distance.

Attention

Before using these controls, thoroughly read instructions in chapter "Moving off".

Attention

Set front brake lever when motorcycle is stopped.

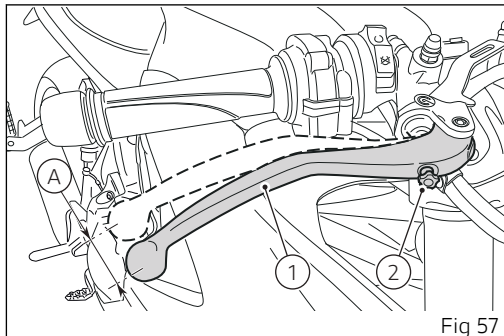

Rear brake pedal

Press pedal (1) down with your foot to operate the rear brake.

The control system is of the hydraulic type.

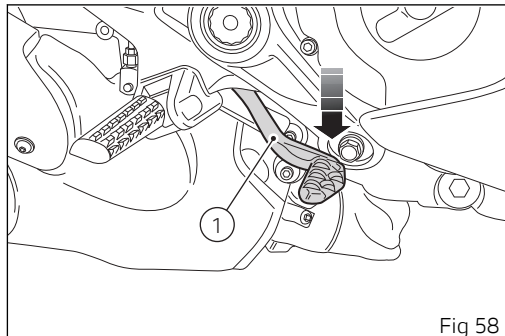

Fig 58

Gear change pedal

The gear change pedal can move in the following two directions and, when released, it automatically returns to rest position N in the centre:

- down = press down the pedal to engage the 1st gear and to shift down. The N light on the instrument panel will go out;
- upwards= lift the pedal to engage 2nd gear and then 3rd, 4th, 5th and 6th gears.

Each time you move the pedal you will engage the next gear.

The central resting condition is indicated by the switching on of the warning light "N" on the instrument panel

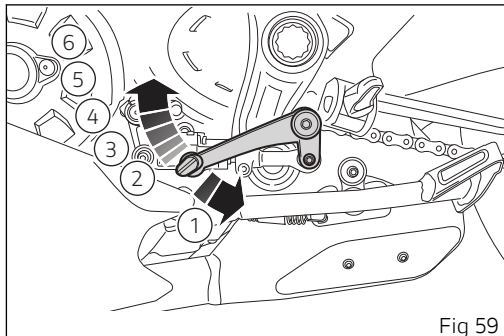
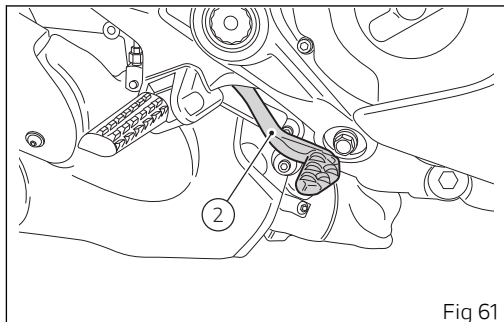
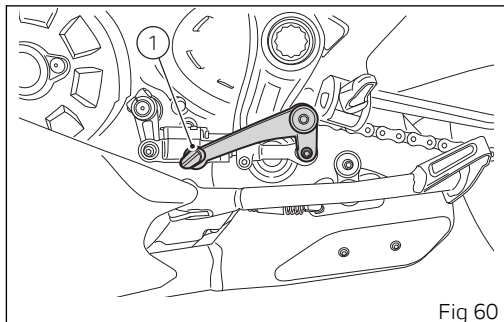

Fig 59

Adjusting the position of the gearchange pedal and rear brake pedal

The position of the gearchange (1) and rear brake (2) pedals in relation to the footrests can be adjusted to suit the requirements of the rider.

Have the gear change pedal and rear brake pedal adjusted at a Ducati Dealer or authorised Service Centre.



Riding the motorcycle

Running-in recommendations

Maximum rotation speed

Rpm for running-in period and during standard use, up to 1000 km (600 mi):

During the first 1000 km (600 mi), keep an eye on the rev counter. It should never exceed: 5,500÷ (included) 6,000 rpm.

During the first hours of riding, it is advisable to run the engine at varying load and rpm, though still within recommended limit.

To this end, roads with plenty of bends and even slightly hilly areas are ideal for a most efficient running-in of engine, brakes and suspensions.

For the first 100 km (60 mi) use the brakes gently. Avoid sudden or prolonged braking. This will allow the friction material on the brake pads to bed in against the brake discs.

For all mechanical parts of the motorcycle to adapt to one another and above all not to adversely affect the life of basic engine parts, it is advisable to avoid

harsh accelerations and not to run the engine at high rpm for too long, especially uphill.

Furthermore, the drive chain should be inspected frequently. Lubricate as required.

During the first 1000 km (600 mi) of the odometer (vehicle running-in period), or up to the first service, a virtual engine rpm limiter is set and is indicated when the wake becomes amber yellow.

When the wake becomes amber yellow and starts blinking, the instrument panel is warning the rider to shift up, so as not to exceed a certain rpm.

If the number of rpm is lower than 1,000 rpm, the wake is not displayed.

Pre-ride checks



Attention

Failure to carry out these checks before riding, may lead to motorcycle damage and injury to rider and passenger.

Before riding, perform the following checks:

- **FUEL LEVEL IN THE TANK**
Check the fuel level in the tank. Refuel if necessary (see "Refuelling").
- **ENGINE OIL LEVEL**
Check oil level in the sump through the sight glass. Top up if necessary (see "Engine oil level check").
- **BRAKE FLUID**
Check fluid level in the corresponding reservoirs ("Checking brake and clutch fluid").
- **COOLANT**
Check the level of coolant in the expansion reservoir; top up if necessary (see "Checking and topping up the coolant level").
- **TYRE CONDITION**
Check tyre pressure and condition (see "Tyres").
- **CONTROLS**

Work the brake, clutch, throttle and gear change controls (levers, pedals and twistgrip) and check for proper operation.

- **LIGHTS AND INDICATORS**

Make sure lights, indicators and horn work properly.

- **KEY LOCKS**

Check the tightening of the filler plug (see "Filler plug") and of the seat (see "Seat lock").

- **STAND**

Make sure side stand operates smoothly and is in the correct position (see "Side stand").

ABS LIGHT

After Key-ON, the ABS light stays ON when the motorcycle speed exceeds 5 km/h (3 mph); the warning light switches OFF to confirm the correct operation of the ABS system.



Attention

In case of malfunction, do not ride the motorcycle and contact a Ducati Dealer or authorised Service Centre.

ABS DEVICE

Check that the front (1) and rear (2) phonic wheels are clean.



Attention

Clogged reading slots would compromise system proper operation. It is recommended to disable ABS system in case of muddy road surface because under this condition the system might be subject to sudden failure.



Attention

Prolonged wheelies could deactivate the ABS system.

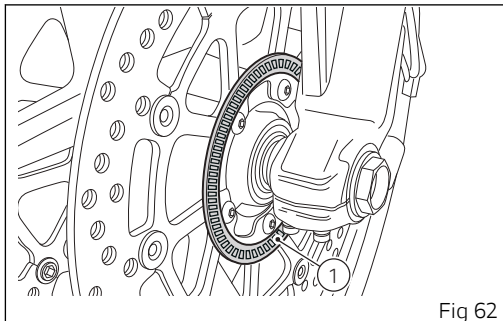

Fig 62

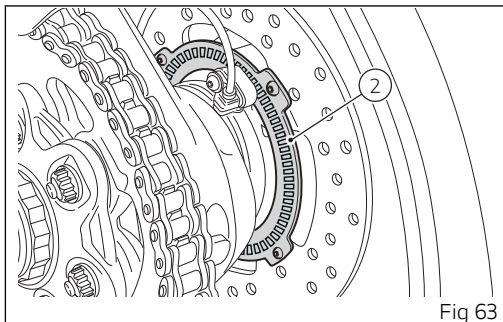



Fig 63

Engine start/stop

Attention

Before starting the engine, become familiar with the controls you will need to use when riding.

Turn the ignition key (1) to "ON".

Turn the ignition switch (2) to the (A)  "RUN" position.

Make sure both the green light N and the red light  on the instrument panel come on.

Let the motorcycle start without operating the throttle control.

Note

If the battery is flat, system automatically inhibits starter motor cranking operation.

Important

Do not rev up the engine when it is cold. Allow some time for oil to be heated and reach all points that need lubricating.

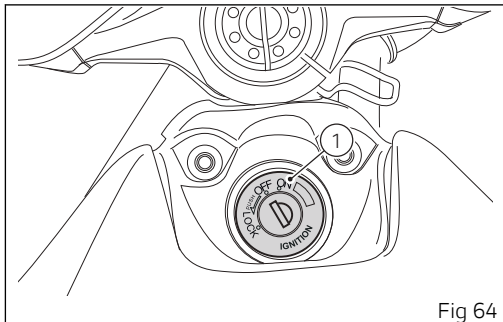

Fig 64

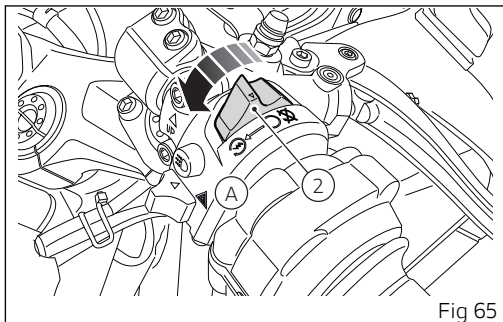



Fig 65



Attention

Keeping the engine running for too long with the vehicle stationary may cause damage due to overheating caused by insufficient cooling. Do not run the engine unnecessarily while the vehicle is stationary. Move immediately after starting the engine.

The red oil pressure warning light  should go out a few seconds after the engine has started.



Attention

Never start or run the engine indoors. Exhaust gases are poisonous and may lead to loss of consciousness or even death within a short time.



Important

The oil pressure light should go out a few seconds after the engine has started.



Attention

The side stand must be fully up (in a horizontal position) as its safety sensor prevents engine starting when down.



Note

It is possible to start the engine with side stand down and the gearbox in neutral. When starting the motorcycle with a gear engaged, pull the clutch lever (in this case the side stand must be up).

The engine will shut off by turning the red switch (2) to the "RUN OFF" position.

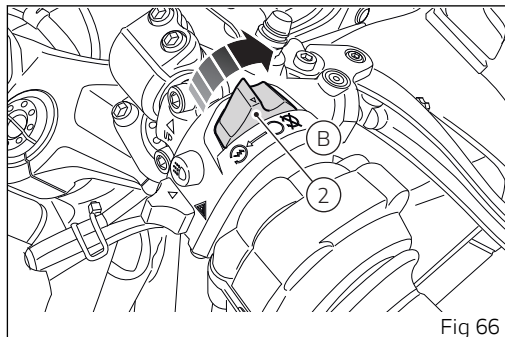

Fig 66

Moving off

Attention

Your motorcycle is equipped with a rev limiter which limits the engine speed to approximately 3000 rpm when the engine is in neutral with the clutch released. This is to prevent excessive noise pollution and also to avoid reaching engine speeds that are harmful to the engine without load. When this limiter comes into operation the revs will be limited and there will be a flashing Overrev indication on the instrument panel. When the clutch is pulled, this function is not active.

- 1) Raise the side stand until it is horizontal, as confirmed by the switching off of the warning light on the instrument panel.
- 2) Squeeze the control lever to disengage the clutch.
- 3) Push down on gear change lever sharply with the tip of your foot to engage the first gear.
- 4) Speed up the engine by turning the throttle twistgrip while gradually releasing the clutch lever; the motorcycle will start moving off.
- 5) Let go of clutch lever and speed up.

- 6) To shift up, close the throttle to slow down engine, disengage the clutch, lift the gear change lever and let go of clutch lever.

To shift down, proceed as follows: release the twistgrip, pull the clutch lever, shortly speed up to help gears synchronise, shift down (engage next lower gear) and release the clutch.

The controls should be used correctly and timely: when riding uphill do not hesitate to shift down as soon as the motorcycle tends to slow down, so you will avoid stressing the engine and the motorcycle abnormally.

Attention

Avoid harsh acceleration, as this may lead to misfiring and transmission snatching. The clutch lever should not be held in longer than necessary after a gear is engaged, otherwise friction parts may overheat and wear out.

Attention

Prolonged wheelies could deactivate the ABS system.

Braking

Slow down in time, shift down to use engine brake and then brake by operating both front and rear brakes. Pull the clutch before the motorcycle stops to avoid engine from suddenly stalling.

Anti-Lock Braking System (ABS)

Using the brakes correctly under adverse conditions is the hardest – and yet the most critical – skill to master for a rider. Braking is one of the most difficult and dangerous moments when riding a two wheeled motorcycle: the possibility of falling or having an accident during this difficult moment is statistically higher than any other moment. A locked front wheel leads to loss of traction and stability, resulting in loss of control.

The Anti-Lock Brake System (ABS) has been developed to enable riders to use the motorcycle braking power to the fullest possible amount in emergency braking or under poor pavement or adverse weather conditions.

ABS uses hydraulics and electronics to limit pressure in the brake circuit when a special sensor mounted to the wheel informs the electronic control unit that the wheel is about to lock up.

This avoids wheel lockup and preserves traction. Pressure is raised back up immediately and the control unit keeps controlling the brake until the risk of a lockup disappears.

Normally, the rider will perceive ABS operation as a harder feel or a pulsation of the brake lever and pedal.

The front and rear brakes use separate control systems, meaning that they operate independently. Likewise, the ABS is not an integral braking system and does not control both the front and rear brake at the same time.

Stopping the motorcycle

Reduce speed, shift down and release the throttle twistgrip.

Shift down to engage first gear and then neutral.

Stop the engine by pushing the switch (3) up to the "RUN OFF" position.

Turn the vehicle key off by turning the ignition key (1) to position (2).

Important

Do not leave the key to ON, position (1), with engine off in order to avoid damaging any electrical components.

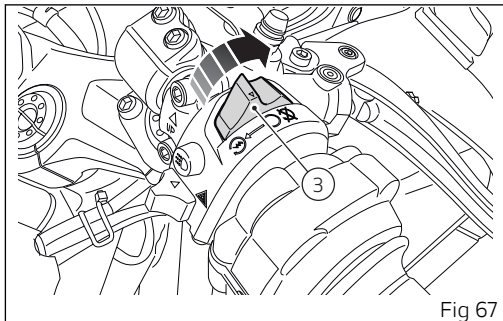

Fig 67

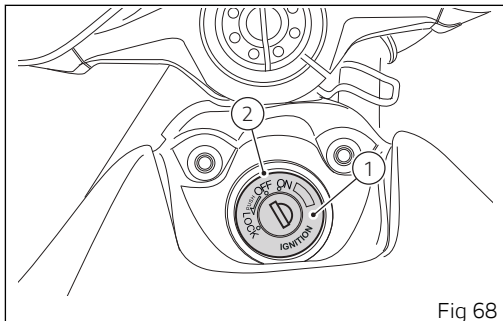

Fig 68

Refuelling

Never overfill the tank when refuelling. Fuel should never be touching the rim of filler recess.

Warning

The fuel pressure inside the tank may, in extreme cases, cause fuel to "spray" when opening the fuel cap.

Always open the fuel cap slowly and carefully during the refill.

If you hear an audible hiss from the cap while opening it, wait until the stop of the hissing before opening it completely.

The sound is residual pressure escaping from the fuel tank, therefore the stop of the hiss indicates that there is no more residual pressure.

The situation described above is more likely in hot weather conditions.

Attention

Use fuel with low lead content and an original octane number of at least 95.

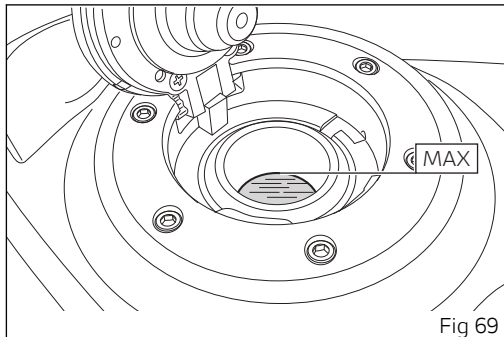

Attention

The motorcycle is only compatible with fuel having a maximum content of ethanol of 10% (E10). Using fuel with ethanol content over 10% is forbidden. Using it could result in severe damage of the engine and motorcycle components. Using fuel with ethanol content over 10% will make the warranty null and void.

Fuel label

The label identifies the fuel recommended for this vehicle.

1) The E5 reference inside the label indicates the use of fuel with a maximum oxygen content of 2.7% by weight and a maximum ethanol content of 5% by volume, according to EN 228.

2) The E10 reference inside the label indicates the use of fuel with a maximum oxygen content of 3.7% by weight and a maximum ethanol content of 10% by volume, according to EN 228.

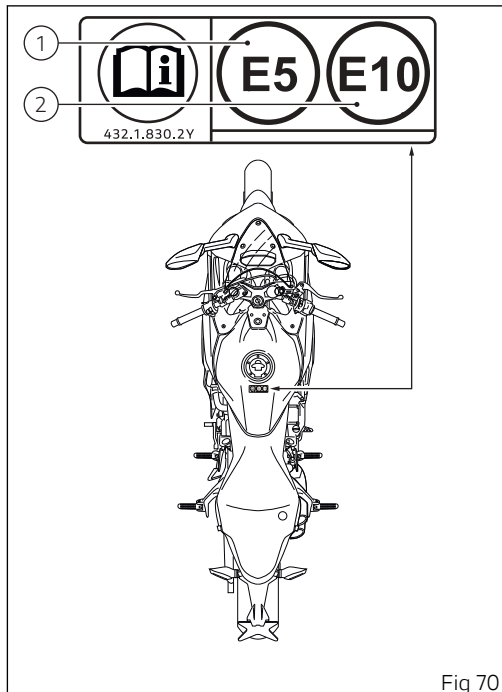

Fig 70

Parking

Park the motorcycle on the side stand.

To prevent theft, turn the handlebar fully left and turn the ignition key to position (3).

If you park in a garage or other indoor area, make sure that there is proper ventilation and that the motorcycle is not near a source of heat.

Attention

Engine, exhaust pipes and silencers stay hot long after the engine is switched off; pay particular attention not to touch the exhaust system with any body part and do not park the vehicle next to flammable material (wood, leaves etc.).

Do not cover the motorbike with the canvas, when the engine and exhaust system are hot, to avoid damaging it.

Attention

Using padlocks or other locks designed to prevent motorcycle motion, such as brake disc locks, rear sprocket locks, and so on is dangerous and may impair motorcycle operation and affect the safety of rider and passenger.

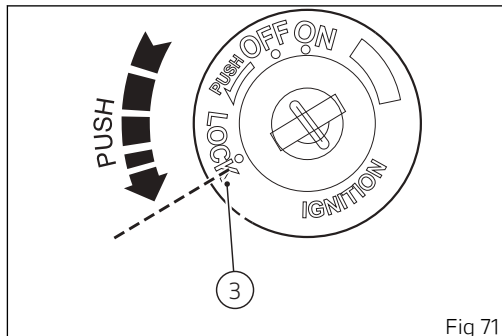

Fig 71

Tool kit and accessories

The tool kit (1) is located in the compartment under the seat.

Tool kit includes:

- fuse pliers;
- two helmet anti-theft system cables;
- flat-blade/Phillips screwdriver;
- screwdriver handgrip;
- tubular wrench 14x16x145 mm (0.55x0.63x5.71 in);
- rod 6x120 mm (0.24x4.72 in);
- Allen wrench 3 mm (0.12 in).
- Allen wrench 4 mm (0.16 in).

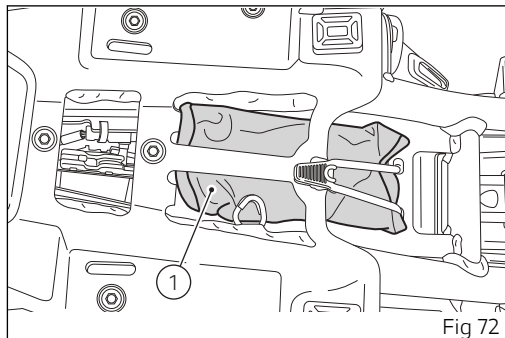

Instrument panel (Dashboard)

Instrument panel

The motorbike is equipped with a COBO instrument panel featuring a TFT colour display.

The instrument panel provides all the information needed for safe driving and allows you to customise the vehicle settings and parameters.

Warning lights

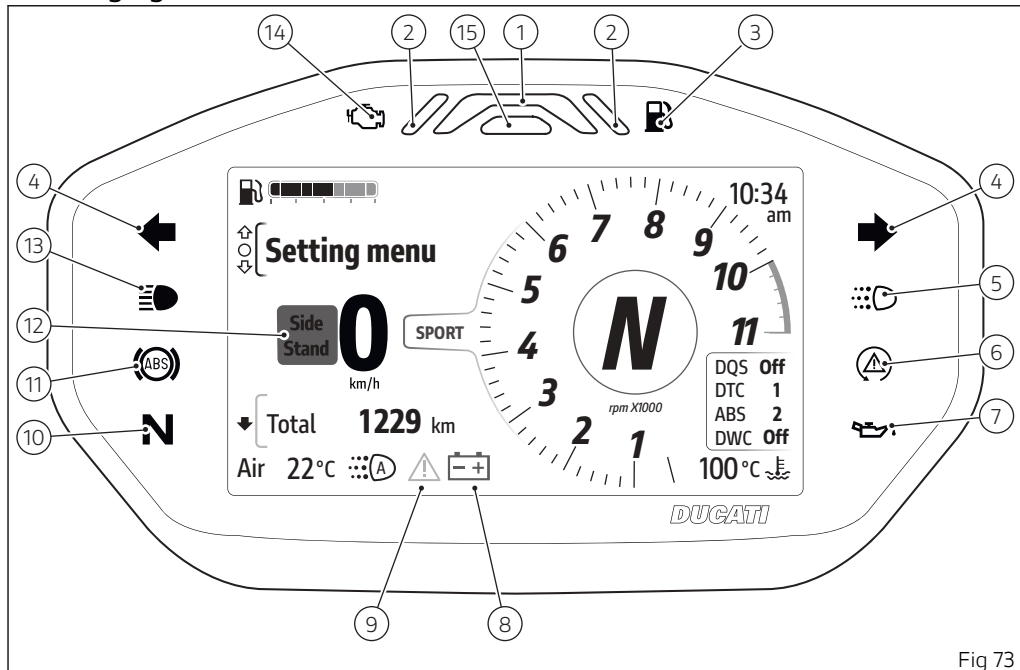



Fig 73

no.	Description	Colour
1	Rev limiter / immobilizer	Red
2	Rev limiter	Red
3	Low fuel	Amber yellow
4	Turn indicators	Green
5	DRL – daytime riding lights on (not present in China and Canada versions)	Green
6	DTC/DWC status <ul style="list-style-type: none"> flashing: DTC/DWC enabled, but with degraded performance; on: DTC/DWC disabled and/or not functioning due to a fault in the control unit. 	Amber yellow
7	Engine oil low pressure  Important If the ENGINE OIL light stays ON, stop the engine or it may suffer severe damage.	Red
8	Low battery charge level	Red (display)
9	Generic error	Amber yellow (display)
10	Neutral gear	Green
11	ABS status <ul style="list-style-type: none"> flashing: ABS in self-diagnosis and/or functioning with degraded performance; 	Amber yellow

no.	Description	Colour
	<ul style="list-style-type: none"> ● on: ABS disabled and/or not functioning due to a fault in the ABS control unit. 	
12	Side stand	Red (display)
13	High beam on	Blue
14	MIL <ul style="list-style-type: none"> ● The warning light turns steady on in case of error in engine management. Proceed slowly, avoid harsh acceleration and overtaking, take the vehicle to a Ducati authorised service centre to eliminate the malfunction. ● The warning light turns on flashing to warn about a critical emission-related error that could damage the catalytic converter. If possible, have the vehicle be taken to a Ducati authorised service centre and the malfunction eliminated and at any rate proceed slowly, avoid harsh acceleration and overtaking. 	Amber yellow
15	DTC/DWC intervention	Amber yellow



Important

If the display shows the message “TRANSPORT MODE”, immediately contact your Ducati Dealer that will delete this message and ensure the full operation of the motorcycle.

Upon key-on, the instrument panel displays the Ducati logo and carries out a sequential check of the LED warning lights.

After this routine, the instrument panel displays the main page in the mode in use before last Key-Off.

During this check stage, if the motorcycle speed exceeds 5 km/h (3 mph), the instrument panel will stop:

- the display check routine and display the standard screen containing updated information;
- the warning light check routine and leave ON only the warning lights that are actually active at the moment.

Main page items



The main screen displays all the information and elements needed for riding.

It is possible to change units of measurement through the "Measurement units" function in the "Setting menu" (page 166)

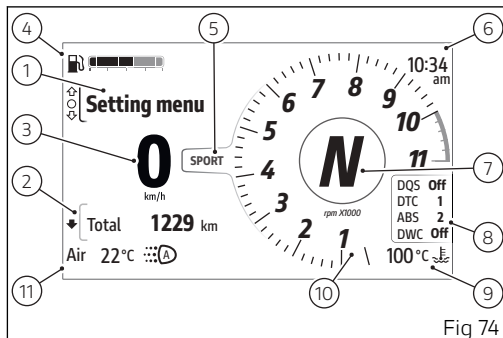
The table lists the available items.



no.	Description
1	Interactive menu
2	Info display
3	Speed It is displayed increased by 5% and together with the set unit of measurement (km/h or mph).
4	Fuel level Available in 2 modes: graduated bar or km or miles remaining. It is possible to set it through the "Fuel indicator" function in the "Setting menu" (page 144).
5	Riding Mode in use Refer to "Riding Mode" (page 109)
6	Clock It is possible to set it through the "Date and time" function in the "Setting menu" (page 152).
7	Gear
8	Parameters window It displays the values of the DQS, DTC, ABS, DWC parameters set for the current Riding Mode. In case of errors on one or more parameters, "Err" is displayed instead of the relevant value. The window disappears when the motorcycle speed exceeds 5 km/h (3 mph) or when the heated handgrips (page 119) are activated.

no.	Description
9	<p data-bbox="178 146 1316 267">Engine Coolant temperature (°C or °F) The temperature display range goes from +40 °C to +120 °C (+104 °F ÷ +248 °F). If the temperature is below +40°C (+104°F), "LO" is displayed, whereas if it is above +120 °C (+248 °F), "HI" is displayed flashing red.</p> <p data-bbox="178 288 1316 519">  <b data-bbox="235 288 386 315">Attention In case of overheating, if possible, it is recommended to ride at reduced speed to allow the cooling system to lower the engine temperature. If this is not possible due to traffic conditions, stop and turn the engine off. If the motorcycle continues to be used when the engine is overheated, severe damage may occur. When the engine temperature returns to normal, continue riding by frequently checking the instrument panel indication. </p>
10	<p data-bbox="178 539 679 591">Rev counter Refer to "Engine rpm indication" (page 112)</p>
11	<p data-bbox="178 612 482 638">Air temperature (°C or °F)</p> <p data-bbox="178 658 1316 721">  <b data-bbox="235 658 315 686">Note When the motorcycle is stopped, the engine heat could influence the displayed temperature. </p>

Interactive menu and Info display

The "Interactive Menu" contains a series of functions that can be activated by the rider. When a function is activated, a corresponding window is displayed with which you can interact.

The "Info display" menu includes all counters referred to available trip information (see page 113)

When one of the menus is selected, it is indicated with the active frame (A, Fig 75) and buttons (1), (2) and (3) are used for menu navigation and interaction. To toggle the selection between "Interactive menu" and "Info display" and vice versa:

- if "Interactive menu" is currently selected, long press and hold button (2) to move the selection to "Info display" (C, Fig 75);
- if "Info display" is currently selected, long press and hold button (1) to move the selection to "Interactive menu" (B, Fig 75).

Buttons (1) and (2) are mainly used to scroll and select items in the selected menu. Button (3) is used to activate and interact with the selected menu item. The left part of the menus shows the following symbols indicating the possible interaction of buttons (1), (2) and (3):

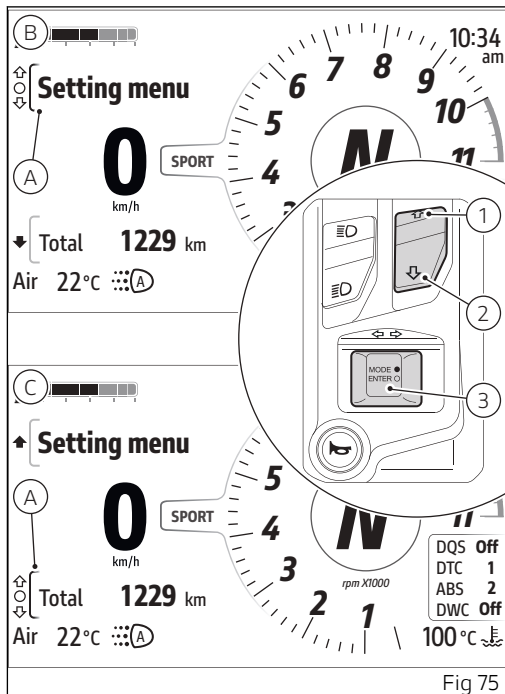

- ↵ short press of button (1);
- ⇩ short press of button (2);
- ○ short press of button (3);
- ⬆ long press of button (1);
- ⬇ long press of button (2);
- ● long press of button (3).

Riding Mode

3 Riding Modes are available: SPORT, TOURING, URBAN.

The name of the active Riding Mode is shown at the centre of the display (A, Fig 76).

Each Riding Mode is associated with a different colour for the name and rev counter box.

The parameters associated to each Riding Mode are: Engine, DTC, ABS, DWC, DQS.

For each Riding Mode it is possible to customise the parameters using the "Riding Mode" function in the "Setting menu" (page 123).

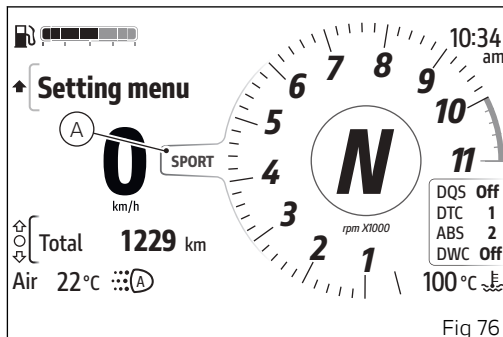

Changing the Riding Mode

- Press and hold the MODE/ENTER button (3) for a long time.
- The dedicated screen is displayed (Fig 78) where, using buttons (1) and (2), it is possible to scroll through the available Riding Modes and display the parameters with the relevant set values.
- Press the MODE/ENTER button (3) to confirm.

Select "Exit" and press MODE/ENTER button (3) to quit the screen without making any changes.

As soon as the new Riding Mode is confirmed, the instrument panel checks the following conditions:

- If speed is lower than or equal to 5 km/h (3 mph) and throttle control is open, the message "Close throttle" is displayed; the new Riding Mode is confirmed and stored only when throttle control is closed and then the main screen is displayed.
- If speed is lower than or equal to 5 km/h (3 mph), throttle control is closed but brakes are actuated, the message "Release brakes" is displayed. The new Riding Mode is confirmed and stored only when brakes are released and then the main screen is displayed.

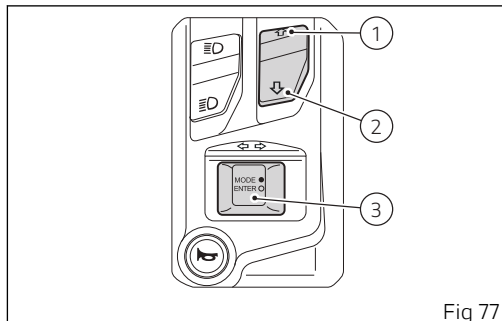

Fig 77

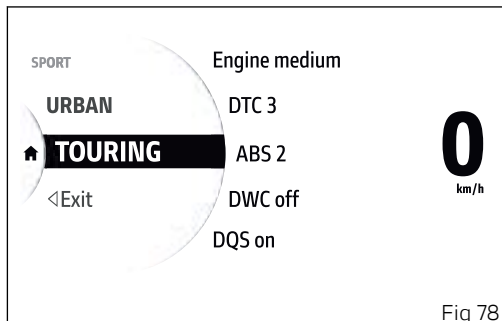

Fig 78

- If both of the above conditions occur, the message "Close throttle and release brakes" is displayed. The new Riding Mode is confirmed and stored only when both conditions are satisfied and then the main screen is displayed.

If either of the conditions required to validate the change of Riding Mode are not true within 5 seconds from activation of one of the above-described conditions, the procedure will be aborted, the instrument panel will go back to displaying the main page and no settings will be changed.



Attention

Ducati recommends changing the Riding mode when the motorcycle is stopped. If the riding mode is changed while riding, be very careful (it is recommended to change the Riding mode at a low speed).

Engine rpm indication

The engine rpm is displayed using a rev counter featuring a grey wake (A).

During the first 1000 km (600 mi) of the odometer (vehicle running-in period), or up to the first service, a virtual engine rpm limiter is set and is indicated when the wake becomes amber yellow.

After the break-in period or after the first inspection, the virtual limiter indicates and advises the rider to ride at lower revs when the engine is cold. The virtual limiter threshold changes according to engine temperature: if the engine temperature is below 50 °C (122 °F), the rpm threshold is 7000 rpm.

When the wake becomes amber yellow and starts blinking, the instrument panel is warning the rider to shift up.

The wake becomes flashing red when the rev limiter trips: in this case the rev limiter (page 100) turns on, too.

If the number of rpm is lower than 1,000 rpm, the wake is not displayed.

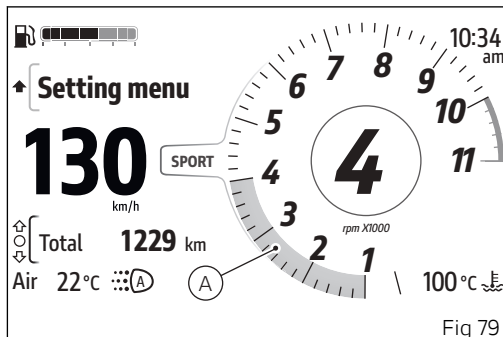

Attention

Your motorcycle is equipped with a rev limiter which limits the engine speed to approximately 3000 rpm when the engine is in neutral with the clutch released. This is to prevent excessive noise pollution and also to avoid reaching engine speeds that are harmful to the engine without load. When this limiter comes into operation the revs will be limited and there will be a flashing Overrev indication on the instrument panel. When the clutch is pulled, this function is not active.

Info display

The "Info display" menu contains all available meters with travel information (A, Fig 80).

To select the "Info display" menu, press and hold the button (2) for a long time.

Once you have selected the "Info display" menu, scroll through the list of information using the buttons (1) and (2).

The units of measurement of the trip information can be changed using the "Measurement units" function in the "Setting menu" (page 166).

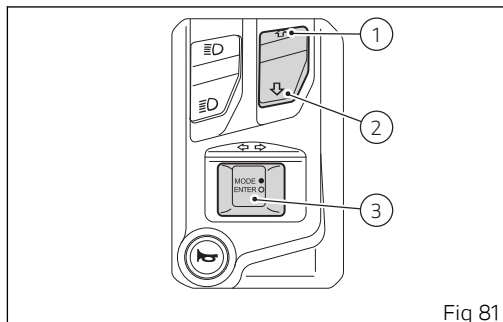
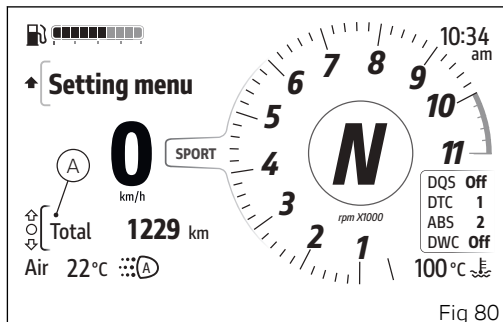

The information contained in the “Info display” menu are listed below.

Name	Description	Measurement units / format
Total	Total odometer	km, miles
Range	Residual range visible only if the fuel level display mode has been set to “Level” (page 144)	km, miles
Trip 1	Partial mileage 1	km, miles
Øcons.1	Average consumption 1	L/100, km/l, mpg UK, mpg US
Øspeed 1	Average speed 1	km/h, mph
Trip 1 time	Travel time 1	hhh:mm
Trip 2	Partial mileage 2	km, miles
Cons.	Instantaneous fuel consumption	L/100, km/l, mpg UK, mpg US

Resetting Trip 1 information

The trip information "Trip 1", "Ø cons.1", "Ø speed 1" and "Trip 1 time", when selected, can be reset by pressing the ENTER button (3): the message "Reset Trip 1 info?" is displayed (Fig 82).

To confirm, press the ENTER button (3). To exit without making any changes, keep button (1) pressed for a long time.

When the Trip 1 information is reset, all the meters that refer to it are reset as well.

Resetting Trip 2 information

The "Trip 2" information, when selected, can be reset by pressing the ENTER button (3): "Reset Trip 2 info?" will be displayed (Fig 83).

To confirm, press the ENTER button (3). To exit without making any changes, keep button (1) pressed for a long time.

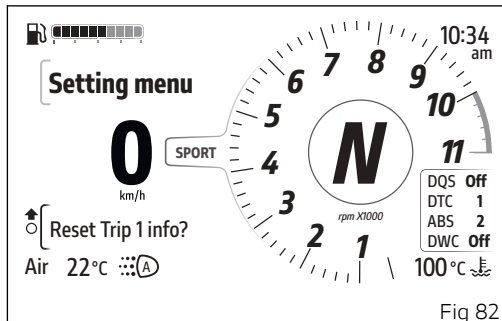

Fig 82

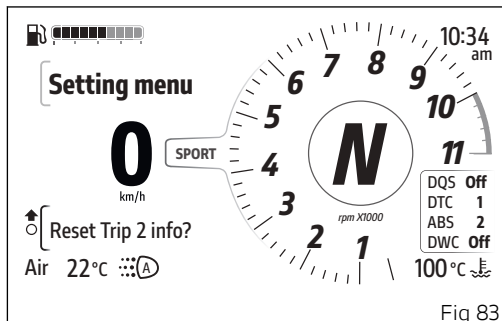
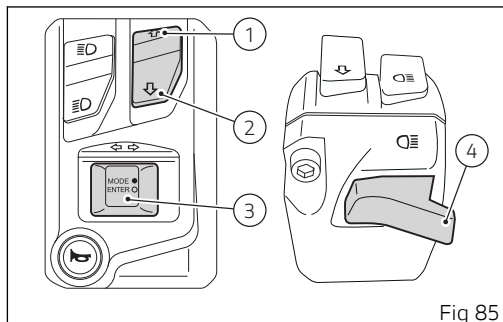
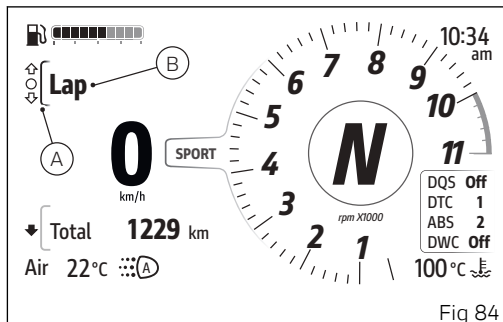

Fig 83

Lap

This function is available inside the Interactive Menu and allows recording the lap times.

- Select the Interactive Menu (A, Fig 84) by pressing and holding button (1) pressed for a long time.
- Use buttons (1) and (2) to select item "Lap" (B, Fig 84) and press the ENTER button (3).



The relevant window (C, Fig 86) is displayed:

- If the function is disabled, "Off" is shown with the stopwatch (D, Fig 87); press ENTER button (3) to enable the function.
- If the function is enabled, "On" is shown with the stopwatch and indication of the available laps (E, Fig 87); press ENTER button (3) to disable the function.

When the function is active, "Lap" is displayed next to the gear indication.

The current lap number is shown, a maximum of 30 laps can be recorded. Once the function is activated, flash button (4, Fig 85) must be used to start/stop the stopwatch: the first time the flash button is pressed, the stopwatch flashes for 1 second.

Then, every time the flash button (4) is pressed, the stopwatch shows the time just completed by flashing for 1 second and remaining steady on for 5 more seconds and returns to display the time in progress.

If the time just completed is the best among those recorded up to that moment, the stopwatch displays the recorded time by flashing for 6 seconds, after which it returns to display the time of the current lap,

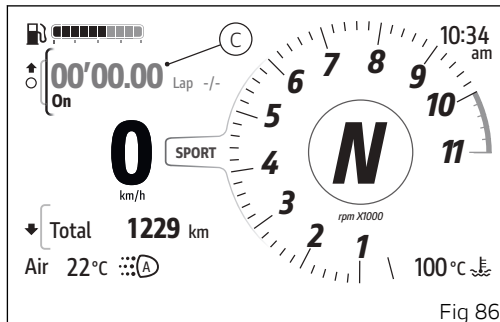

Fig 86

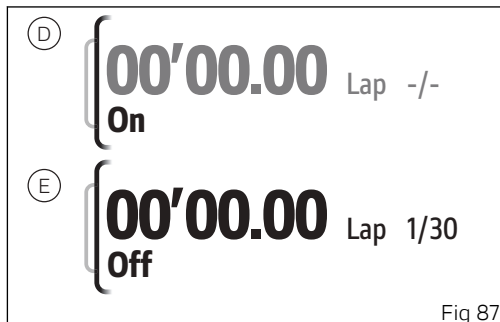

Fig 87

updating the number of laps. When the 30th lap is reached, the message "Full memory" is displayed and it is not possible to record new times: in this case, delete the saved laps in order to record new ones. Using the "Lap" function in the "Setting menu" (page 158) it is possible to:

- Activate or deactivate the function
- View the recorded lap data
- Delete recorded data

To close the window, press and hold button (1) for a long time. The window can be closed keeping the function active.

The instrument panel stops recording the lap by resetting the stopwatch in the following cases:

- If bike speed is equal to 0 after 5 seconds from first lap start.
- If bike speed drops below 5 km/h (3 mph) for more than 5 seconds during lap recording.
- If the engine is turned off.

The following data is recorded for each lap:

- Time
- Maximum reached speed
- Maximum reached rpm
- Maximum leaning angle

- Maximum yaw angle



Note

The stopwatch can be started only when the motorcycle speed is higher than 5 km/h (3 mph).



Note

If during lap recording the flash button (4) is pressed to start/stop the stopwatch, any further button presses occurred within 5 seconds will not be considered by the instrument panel.

Heated handgrips

This function allows the user to activate and set the handgrip heating.

- Select the Interactive Menu (A, Fig 88) by pressing and holding button (1) pressed for a long time.
- Use buttons (1) and (2) to select item "Heated Grips" (B, Fig 88) and press the ENTER button (3).

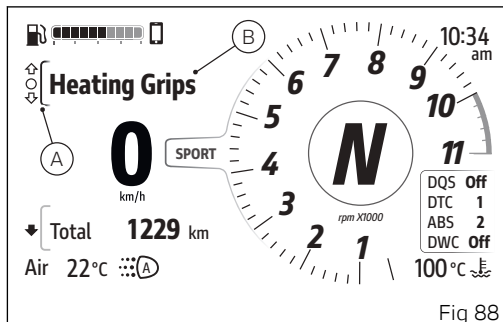

Fig 88

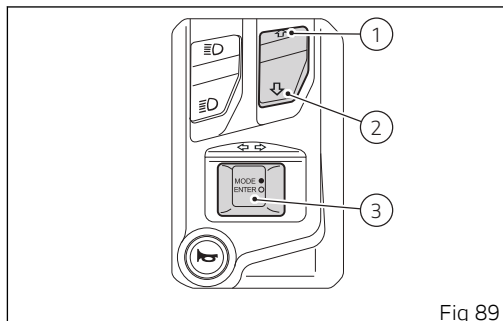

Fig 89

Window (C, Fig 90) is displayed for adjusting the handgrip heating; here the 4 available levels (High, Medium, Low, Off) and the "Back" item are listed. Use buttons (1) and (2) to scroll through the available levels. Press the ENTER button (3) to confirm the selected level. To close the window, select the "Back" item and press the ENTER (3) button, or press and hold button (1).

Each level is associated with an icon (D, Fig 90), displayed in grey when heating is off. When the heating is activated, the icon turns black if the display is in "day" mode and white if the display is in "night" mode.

To change the "day" or "night" display mode, refer to the chapter "Setting menu - Backlight" (page 146).

Note

The actual turning on (heating) of the heated handgrips occurs only with engine started, and when a certain number of engine rpm have been reached and maintained: heating power is limited to 50% up to 2,000 rpm.

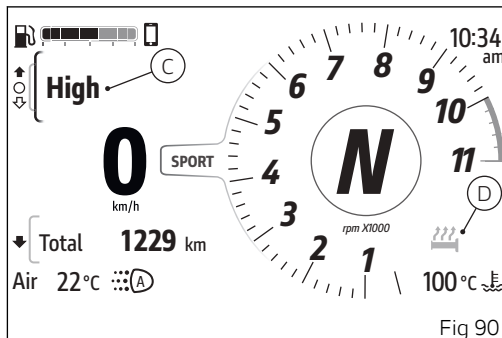

Fig 90

Setting menu

This menu allows enabling, disabling and setting some motorcycle functions.

For safety reasons, you can enter this Menu only when the speed is lower than or equal to 5 km/h (3 mph). If you are inside the Setting menu and the speed exceeds 5 km/h (3 mph) the instrument panel automatically exits from the setting menu. It is recommended to use this menu with the motorcycle at a standstill.

- Select the Interactive Menu (A, Fig 91) by pressing and holding button (1) pressed for a long time.
- Use buttons (1) and (2) to select item "Setting menu" (B, Fig 91) and press the ENTER button (3).

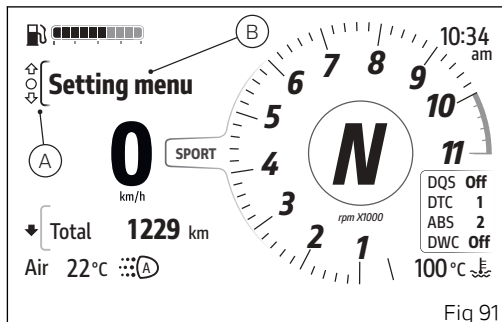

Fig 91

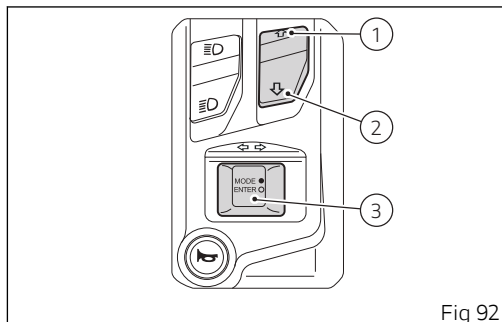

Fig 92

The instrument panel displays the dedicated page listing the available settings:

- Riding Mode
- Fuel Indicator
- DRL (if present)
- Backlight
- PIN Code
- Date and time
- Service
- Lap
- Tyre calibration
- Bluetooth (see page 19)
- Turn indicators
- Measurement units
- Info

Buttons (1), (2) and (3) are used as follows when displaying the Setting menu:

- buttons (1) and (2) to scroll and select the available items;
- ENTER button (3) to confirm the selected item.

To exit the sub-menus of the Setting menu, select the "Back" item and press the ENTER button (3).

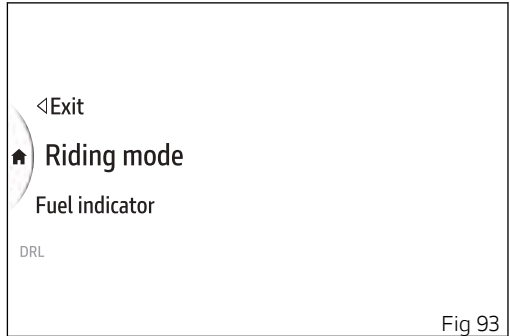

To exit the Setting menu and return to the main screen, select the "Exit" item and press the ENTER button (3).

Setting menu - Riding Mode

This function allows customising each Riding mode.

- Use buttons (1) and (2) from the Interactive Menu to select the "Setting menu" item and press ENTER (3).
- Select the "Riding Mode" item and press ENTER (3).

The "Sport", "Touring", "Urban" Riding Modes and "Default" item are displayed (only visible if one or more parameters of one or more riding modes have been changed). The active Riding Mode (Fig 95) is displayed on the right side.

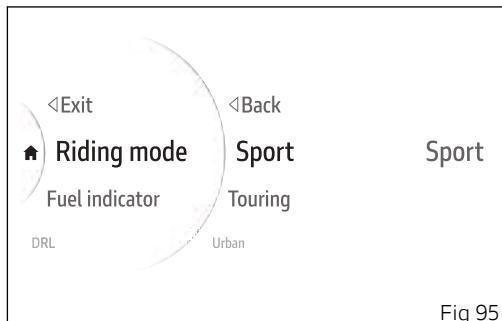
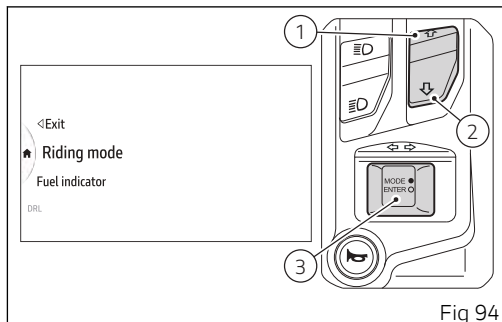

Use buttons (1) and (2) to select the Riding mode you wish to customise and press ENTER.

The customisable parameters are the following:

- Engine
- DTC
- ABS
- DWC
- DQS
- Default (visible only if one or more parameters of the selected Riding Mode have been changed)

The motorbike is shown in the middle of the screen with the part relevant to the selected item highlighted, press ENTER to modify the parameters.

Attention

Changes should only be made to the parameters by people who are experts in motorcycle set-up. If the parameters are changed accidentally, use the "Default" function to restore factory settings.



Fig 96

Setting menu - Riding Mode - Engine

This function allows setting the engine power.

- Use buttons (1) and (2) from the Interactive Menu to select the "Setting menu" item and press ENTER (3).
- Select the "Riding Mode" item and press ENTER (3).
- Select the Riding Mode you wish to customise and press ENTER (3).
- Select the "Engine" item and press ENTER (3).

Levels "High", "Medium" and "Low" are displayed on the left-hand side. While the currently set level is shown on the right. The motorbike is shown in the middle with the part involved in the setting highlighted and the reference indications.

Use buttons (1) and (2) to scroll and select the desired level. Press ENTER (3) to confirm and quit the setting menu.

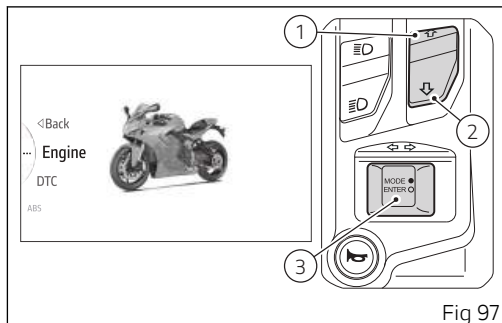

Fig 97

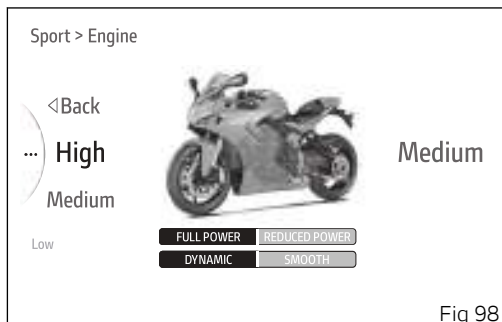

Fig 98

Setting menu - Riding Mode - DTC

This function allows setting the intervention level of the DTC traction control system or deactivating it.

- Use buttons (1) and (2) from the Interactive Menu to select the "Setting menu" item and press ENTER (3).
- Select the "Riding Mode" item and press ENTER (3).
- Select the Riding Mode you wish to customise and press ENTER (3).
- Select the "DTC" item and press ENTER (3).

Levels from 1 to 8 and "Off" are displayed on the left-hand side. While the currently set level is shown on the right. The motorbike is shown in the middle with the part involved in the setting highlighted and the reference indications.

Use buttons (1) and (2) to scroll and select the desired level. Press ENTER (3) to confirm and quit the setting menu.

Attention

When the DTC is set to Off, the DWC is also automatically set to Off, so both the wheelie control and the vehicle dynamics stabilisation control are deactivated.

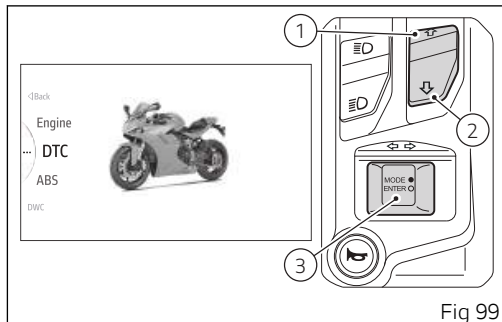

Fig 99

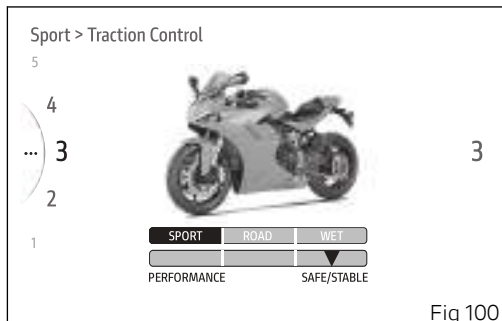

Fig 100

The Ducati Traction Control system (DTC) supervises the rear wheel slipping control and settings vary through eight different levels that are calibrated to offer a different tolerance level to rear wheel slipping. Each Riding Mode features a pre-set intervention level. Level 8 indicates system intervention whenever a slight slipping is detected, while level 1 is for off-road use and very expert riders because it is less sensitive to slipping and intervention is hence softer.



Attention

The DTC is a rider assist system. The system is designed to make riding easier and to enhance safety, but in no way relieves the rider of the obligation to drive responsibly and to maintain a high standard of riding in order to avoid accidents, whether caused by his own errors or those of other road users, through making emergency manoeuvres, in accordance with the prescriptions of the road traffic code.

The rider must always be aware that active safety systems have a preventive function. The active elements help the rider control the motorcycle, making it as easy and safe to ride as possible. The presence of an active safety system should not

encourage the rider to ride at speeds beyond the reasonable limits, not in accordance with the road conditions, the laws of physics, good riding standards and the requirements of the road traffic code.

The following table indicates the most suitable level of DTC intervention for the various riding modes as well as the default settings in the "Riding Mode" that can be selected by the rider.

DTC LEVEL	RIDING MODE	OPERATION CHARACTERISTIC	DEFAULT
OFF		The DTC is disabled.	NO
1	SPORT	Sports style for very expert riders. System permits sliding sideways.	NO
2	SPORT	Sports style for expert riders. System permits sliding sideways.	NO
3	SPORT	Sports style for medium-expert riders. System permits sliding sideways.	It is the default level for the "SPORT" Riding Mode
4	TOURING	Fast touring style.	NO
5	TOURING	Touring style.	It is the default level for the "TOURING" Riding Mode
6	URBAN	"Very safe" style on any kind of path.	It is the default level for the "URBAN" Riding Mode
7	RAIN	For riding on slightly wet or moist road. ENGINE LOW setting recommended.	NO
8	HEAVY RAIN	For riding on wet road. ENGINE LOW setting recommended.	NO

Tips on how to select the intervention level



Attention

All levels of the DTC system of your vehicle have been calibrated with original equipment tyres (Pirelli Diablo Rosso III 120/70 - 17 front and Pirelli Diablo Rosso III 180/55 - 17 rear). The use of tyres of different size and characteristics to the original tyres may alter the operating characteristics of the system.

In the case of minor differences, such as for example, tyres of a different make and/or model than the OE ones, but with the same size (front = 120/70 - 17, rear = 180/55 - 17), it may be sufficient to simply select the suitable level setting from those available in order to restore optimal system operation. If tyres of a different size class are used or if the tyre size differs significantly from the original tyres, it may be that the system operation is affected to the point where none of the 8 available level settings will give satisfactory results. In this case it is advisable to deactivate the traction control system.

If level 8 is selected, the DTC system will kick in at the slightest hint that the rear wheel is starting to spin. Between level 8 and level 1 there are intermediate

levels. DTC intervention decreases from level 8 to level 1. Levels 1, 2 and 3 allow both spinning and skidding of the rear wheel out of a corner: these levels are recommended only for expert riders.

The choice of the correct level mainly depends on the following parameters:

- 1) The tyre/asphalt grip (type of tyre, amount of tyre wear, the road/track surface, weather conditions, etc.);
- 2) The characteristics of the path/circuit (bends all taken at similar speeds or at very different speeds);
- 3) The riding mode (whether the rider has a "smooth" or a "rough" style).

Level depends on grip conditions:

the choice of level setting depends greatly on the grip conditions of the track/path (see below, tips for use on the road).

Level depends on type of track/path:

if the track/path features bends all taken at similar speeds, it will be easier to find a level suitable for all bends; while a track/path with bends all requiring

different speeds will require a DTC level setting that is the best compromise for all bends.

Level depends on riding style:

The DTC will tend to kick in more with a "smooth" riding style, where the motorcycle is leaned over further, rather than with a "rough" style" where the motorcycle is straightened up as quickly as possible when exiting a turn.

Tips for use on dry road

Activate the DTC, select level 6 and ride the motorcycle in your usual style; if the level of DTC sensitivity seems excessive, try levels 5, 4, etc., until you find the one that suits you best. If changes occur in the grip conditions and/or circuit characteristics and/or your riding style, and the level setting is no longer suitable, switch to the next level up or down and proceed to determine the best setting (e.g. if with level 5 the DTC intervention seems excessive, switch to level 4; alternatively, if on level 5 you cannot perceive any DTC intervention, switch to level 6).

Tips for use on wet road

Level 7 is recommended when road is slightly wet or damp and level 8 on wet road. It is also recommended to select ENGINE LOW in these conditions.

Setting menu - Riding Mode - ABS

This function allows setting the ABS intervention level.

- Use buttons (1) and (2) from the Interactive Menu to select the "Setting menu" item and press ENTER (3).
- Select the "Riding Mode" item and press ENTER (3).
- Select the Riding Mode you wish to customise and press ENTER (3).
- Select the "ABS" item and press ENTER (3).

Levels from 1 to 3 are displayed on the left-hand side. While the currently set level is shown on the right. The motorbike is shown in the middle with the part involved in the setting highlighted and the reference indications.

Use buttons (1) and (2) to scroll and select the desired level. Press ENTER (3) to confirm and quit the setting menu.

Using the brakes correctly under adverse conditions is the hardest – and yet the most critical - skill to master for a rider. Braking is one of the most difficult and dangerous moments when riding a two wheeled motorcycle: the possibility of falling or having an

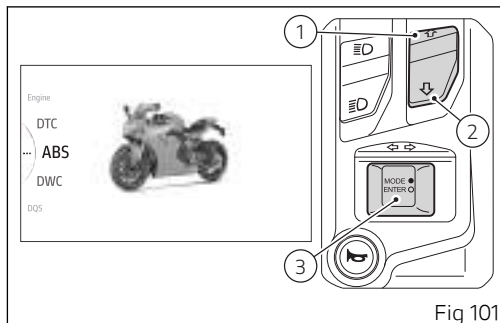

Fig 101

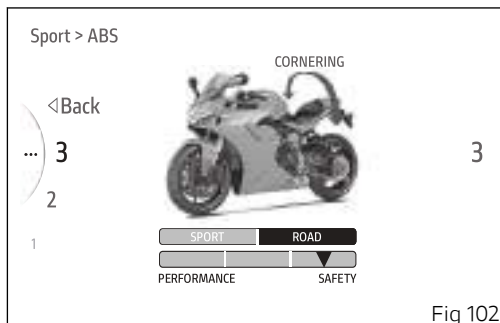

Fig 102

accident during this difficult moment is statistically higher than any other moment. When one or both wheels lock, the stabilising action of traction fails, resulting in loss of control of the vehicle.

The Anti-Lock Brake System (ABS) has been developed to enable riders to use the motorcycle braking power to the fullest possible amount in emergency braking or under poor pavement or adverse weather conditions. ABS is an electro-hydraulic device that controls the pressure in the brake circuit when the control unit, by processing information from wheel sensors, determines that one or both wheels are about to lock up. This avoids wheel lockup and preserves traction within the limits of the system. After that, the control unit restores the pressure in the circuit, to resume the braking action. This cycle is repeated many times until the problem is completely eliminated. Normally, the rider will perceive ABS operation as a harder feel or a pulsation of the brake lever or pedal. The front and rear brakes use separate control systems.

The active presence of ABS strategies and their intervention level depend on the selected level. The ABS features three levels, one associated to each Riding Mode.

The SuperSport ABS features a "cornering" function that optimises ABS functionality to the conditions where the motorcycle is leaning over, thus preventing wheel lock-up and slipping as much as possible, within the physical limits allowed by the vehicle and by the road conditions. The cornering feature is active in ABS levels 2 and 3. According to the selected level, the SuperSport ABS can implement the anti lift-up function for the rear wheel so as to guarantee not only a reduced stopping distance under braking, but also the highest possible stability.



Attention

Using the two brake controls separately reduces the motorcycle braking power. Never use the brake controls harshly or suddenly as you may cause wheel lock-up or rear wheel lift-up and lose control of the motorcycle. When riding in the rain or on slippery surfaces, braking will become less effective. Always use the brakes very gently and carefully when riding under these conditions. Any sudden manoeuvres may lead to loss of control. When tackling long, high-gradient downhill road tracts, shift down gears to use engine braking. Apply one brake at a time and use brakes sparingly. Keeping the brakes applied all the time would cause the friction material to overheat and reduce braking power dangerously. Underinflated tyres reduce braking efficiency, handling accuracy and stability in a bend.

The following table indicates the most suitable level of ABS intervention for the various riding types as well as the default settings in the "Riding Mode" that can be selected by the rider:

ABS LEVEL	RIDING MODE	OPERATION CHARACTERISTIC	DEFAULT
1	SPORT	This level is thought for extremely expert users. ABS in this level only controls the front wheel, and thus allows rear wheel lockup. The system in this level does NOT control the lift-up.	This level is not associated by default with any Riding Mode.
2	ROAD & SPORT	This level is designed for road use, with good grip conditions. ABS in this level controls both wheels and the cornering and anti-lift-up functions are active. This calibration favours braking power and can allow partial lift-up of the rear wheel.	It is the default level for the "SPORT" Riding Mode
3	ROAD	This level is designed for use in any riding conditions to provide a safe and consistent braking action. ABS in this level controls both wheels and the cornering and anti-lift-up functions are active.	It is the default level for the "TOURING" and "URBAN" Riding Modes

Tips on how to select the intervention level



Attention

Excellent operation of the ABS system, for all available levels, is ensured only with the OE brake system and with OE tyres and/or with the ones recommended by Ducati. In particular, OE tyres for this motorcycle are Pirelli Diablo Rosso 3-D in the following sizes: front 120/70 R17 58W, rear 180/55 R17 73W. The use of tyres of different size and characteristics to the original tyres may alter the operating characteristics of the system thus making it unsafe. It is recommended not to install tyres of different size than the ones approved for your vehicle.

Selecting level 3, the ABS will ensure a kind of braking that privileges stability thanks to lift-up control, and the motorcycle will keep a good alignment during the whole braking action. ABS level 3 features active cornering function which, with vehicle leaning over, prevents wheel lockup and slipping as much as possible, within the physical limits allowed by the vehicle and by the road conditions. Selecting level 2, the ABS will privilege more the braking power and performance. ABS level

2 provides also lift-up control and cornering feature. ABS level 1 is specific for track use and ABS is active only on the front wheel. In this level, the Cornering feature and the lift-up control are not implemented.

The choice of the correct level mainly depends on the following parameters:

- 1) The tyre/road grip (type of tyre, amount of tyre wear, the road/track surface, weather conditions, etc.).
- 2) The rider's experience and sensitivity: expert riders can tackle a lift-up in trying to reduce the stopping distance to a minimum, while less expert riders are recommended to use setting 3, that will help them keeping the motorcycle more stable even in emergency braking.

Setting menu - Riding Mode - DWC

This function allows setting the intervention level of the DWC or deactivating it.

- Use buttons (1) and (2) from the Interactive Menu to select the "Setting menu" item and press ENTER (3).
- Select the "Riding Mode" item and press ENTER (3).
- Select the Riding Mode you wish to customise and press ENTER (3).
- Select the "DWC" item and press ENTER (3).

Levels from 1 to 4 and "Off" are displayed on the left-hand side. While the currently set level is shown on the right. The motorbike is shown in the middle with the part involved in the setting highlighted and the reference indications.

Use buttons (1) and (2) to scroll and select the desired level. Press ENTER (3) to confirm and quit the setting menu.

Attention

When the DTC is set to Off, the DWC is also automatically set to Off, so both the wheelie control and the vehicle dynamics stabilisation control are deactivated.

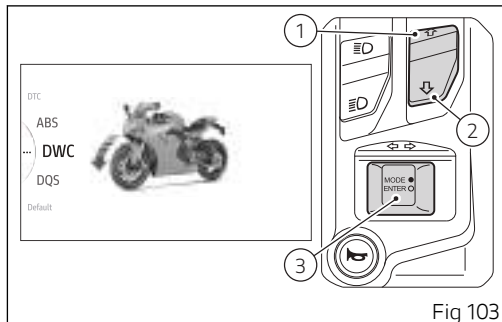

Fig 103

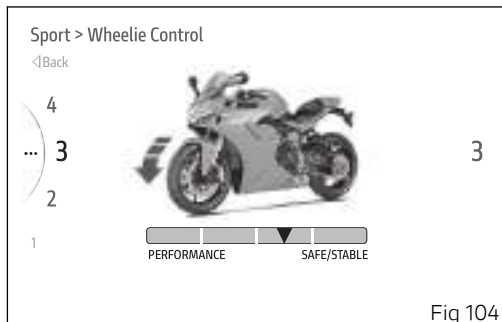

Fig 104

The Ducati Wheelie Control system (DWC) supervises control of wheelie movement and settings vary through 4 different levels that are calibrated to offer a different prevention and reaction to wheelies. Each Riding Mode features a pre-set intervention level. Level 4 indicates a setting that minimises motorcycle tendency to shift up in a wheelie and maximises reaction to the same, if it occurs. While level 1 is for expert riders and features a lower wheelie control in terms of prevention and less strong reaction to the same, if it occurs.



Attention

The DWC is a rider assist system. The system is designed to make riding easier and to enhance safety, but in no way relieves the rider of the obligation to drive responsibly and to maintain a high standard of riding in order to avoid accidents, whether caused by his own errors or those of other road users, through making emergency manoeuvres, in accordance with the prescriptions of the road traffic code.

The rider must always be aware that active safety systems have a preventive function. The active elements help the rider control the motorcycle, making it as easy and safe to ride as possible. The

presence of an active safety system should not encourage the rider to ride at speeds beyond the reasonable limits, not in accordance with the road conditions, the laws of physics, good riding standards and the requirements of the road traffic code.

The following table indicates the most suitable level of DWC intervention for the various riding types as well as the default settings in the "Riding Mode" that can be selected by the rider:

DWC LEVEL	RIDING MODE	OPERATION CHARACTERISTIC	DEFAULT
OFF		The DWC is disabled.	NO
1	SPORT	Sports style for expert riders. The system allows wheelies, but decreases the speed at which the front wheel lifts.	NO
2	SPORT	Sports style for medium-expert riders. The system allows wheelies, but decreases the speed at which the front wheel lifts.	It is the default level for the "SPORT" Riding Mode
3	TOURING	Level for all kinds of riders. The system reduces the motorcycle's proneness to do wheelies and sensitively intervenes in case of wheelie.	It is the default level for the "TOURING" Riding Mode
4	URBAN	Level for all kinds of riders. The system reduces the motorcycle's proneness to do wheelies and sensitively intervenes in case of wheelie.	It is the default level for the "URBAN" Riding Mode

Tips on how to select the intervention level



Attention

Excellent operation of the DWC system, for all available levels, is ensured only with the OE final drive ratio and with OE tyres and/or with the ones recommended by Ducati. In particular, OE tyres for this motorcycle are Pirelli Diablo Rosso III in the following sizes: 120/70 ZR17 at the front, 180/55 ZR17 at the rear. The use of tyres of different size and characteristics to the original tyres may alter the operating characteristics of the system thus making it unsafe. It is recommended not to install tyres of different size than the ones approved for your vehicle.

At level 4 the DWC system reduces the motorcycle's proneness to do wheelies to a minimum level and sensitively intervenes in case of wheelie. Between level 4 and level 1 there are further intermediate levels of intervention for the DWC. Levels 1 and 2 allow easier wheelies, but reduce their speed: these levels are recommended only for expert riders who can control wheelies on their own and exploit the system feature that reduces the speed at which the front wheel tends to lift.

The choice of the correct level mainly depends on the following parameters:

- the rider's experience;
- the characteristics of the path/circuit (bend exit with low or high gear engaged).

The rider's experience

The choice of level setting depends greatly on the riders' experience and ability to control wheelies on their own. Levels 1 and 2 require a great experience to ensure proper control.

Level depends on type of path

If the path allows exiting a turn with strong accelerations a high level will be necessary (the highest level is 4); while a path that requires exiting a turn with low accelerations will allow setting a lower level (the lowest level is 1).

Tips for use on the road

Activate the DWC, select level 4 and ride the motorcycle in your usual style; if the level of DWC sensitivity seems excessive, try levels 3, 2, etc., until you find the one that suits you best. If changes occur in the circuit characteristics, and the level setting is no longer suitable, switch to the next level up or

down and proceed to determine the best setting (e.g. if with level 3 the DWC intervention seems excessive, switch to level 2; alternatively, if on level 3 you cannot perceive any DWC intervention, switch to level 4).

Setting menu - Riding Mode - DQS

This function allows activating or deactivating the DQS system.

- Use buttons (1) and (2) from the Interactive Menu to select the "Setting menu" item and press ENTER (3).
- Select the "Riding Mode" item and press ENTER (3).
- Select the Riding Mode you wish to customise and press ENTER (3).
- Select the "DQS" item and press ENTER (3).

Levels "On" and "Off" are displayed on the left-hand side. While the currently set level is shown on the right. The motorbike is shown in the middle with the part involved in the setting highlighted and the reference indications.

Use buttons (1) and (2) to scroll and select the desired level. Press ENTER (3) to confirm and quit the setting menu.

The DQS with up/down feature allows the rider to upshift and downshift without using the clutch lever. It includes a two-way microswitch - built in the lever mechanism - that outputs a signal to the engine control unit whenever the gearchange is operated.

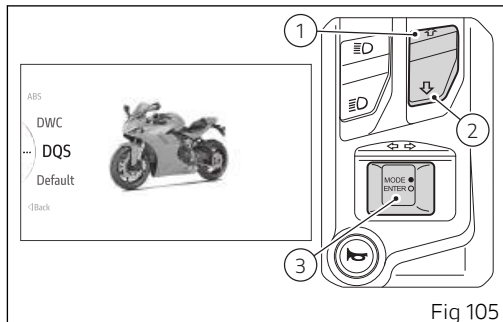

Fig 105

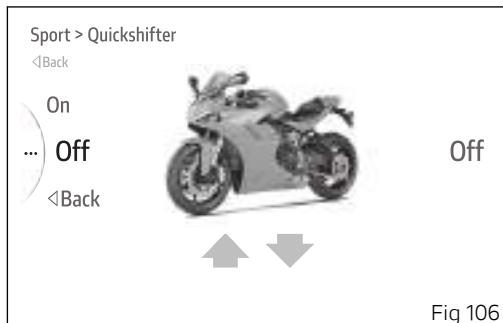

Fig 106

The system works in a separate way for upshifting and downshifting, and combines the action on ignition advance and injection, available in the upshift system, with controlled throttle opening for operation during downshifting.

Extent and duration of these actuations aim at ensuring excellent engagement smoothness under any riding condition; system works in synergy with slipper clutch during downshifting.

- The Ducati Quick Shift takes the same shift lever operation as with vehicle not equipped with the Ducati Quick Shift. Ducati Quick Shift is not designed for shifting automatically.
- For any gearshift request (up or down) the rider has to move the shift lever from its idle position in the desired direction against the force of the spring through a certain over-travel, then keep the shift lever in this position until the gearshift is completed. Once the gearshift has been completed, the lever has to be fully released in order to allow another gearshift acted by Ducati Quick Shift. If the rider does not move the shift lever up to end stroke during a Ducati Quick Shift request, gears may not be fully engaged.
- Ducati Quick Shift provides no assistance for the gearshift if the rider uses the clutch lever: the

Ducati Quick Shift does not work when the clutch lever is pulled.

- Ducati Quick Shift will shift down only when the throttle control is completely closed.
- If the Ducati Quick Shift strategy does not work it is always possible to complete the gear shifting using the clutch lever.
- If the gear lever is held pressed up or down for more than 30 seconds (even if just by accident) a plausibility error can be memorised in the electronic control unit and the Ducati Quick Shift system could be disabled; in this case, a simple key-off and key-on cycle will reactivate the system.
- Ducati Quick Shift is designed to operate above 2,500 rpm.
- No matter the gear engaged, downshifting with Ducati Quick Shift only works below a set threshold, so as to avoid exceeding the maximum rpm allowed when the lower gear is engaged.

Setting menu - Riding Mode - Default

This function allows restoring the values of the parameters linked to the Riding Modes set by Ducati, and is visible only if the parameters have been previously modified.

Resetting the parameters for a single Riding Mode:

- Use buttons (1) and (2) from the Interactive Menu to select the "Setting menu" item and press ENTER (3).
- Select the "Riding Mode" item and press ENTER (3).
- Select the Riding Mode you wish to customise and press ENTER (3).
- Select the "Default" item and press ENTER (3). The message "Wait..." is displayed for a few seconds followed by the message "Default Ok". Then "Default" disappears from the menu list.

Resetting the parameters for all Riding Modes:

- Use buttons (1) and (2) from the Interactive Menu to select the "Setting menu" item and press ENTER (3).

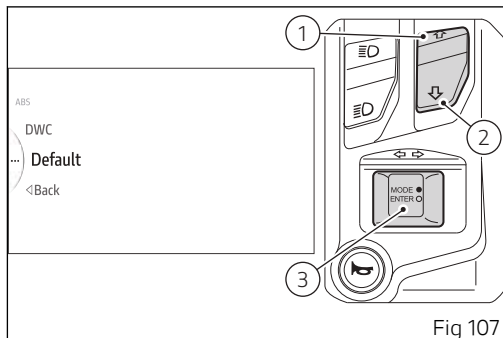

- Select the "Riding Mode" item and press ENTER (3).
- Select the "Default" item and press ENTER (3). The message "Wait..." is displayed for a few seconds followed by the message "Default Ok". Then "Default" disappears from the menu list.

Setting menu - Fuel indicator

This function allows changing the display mode of the fuel level, by choosing among graduated bar or remaining km or miles.

- Use buttons (1) and (2) from the Interactive Menu to select the "Setting menu" item and press ENTER (3).
- Select the "Fuel indicator" item and press ENTER (3).

"Level" and "Range" are displayed in the middle. While the currently set mode is shown on the right. Use buttons (1) and (2) to scroll and select the desired mode. Press ENTER (3) to confirm.

Note

When the fuel level is set to remaining km or miles, the Range item is not displayed in the Info display list.

Note

When the fuel is low, the relevant indicator is forced in the remaining km or mile mode.

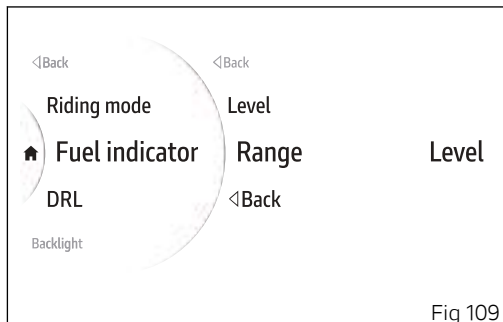
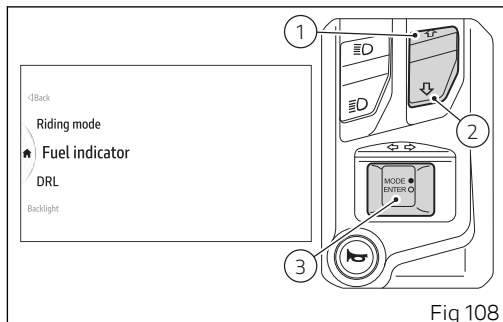

Setting menu - DRL

This function allows setting the status of the DRL in automatic or manual mode. Available only if daytime running lights (DRL) are present.

- Use buttons (1) and (2) from the Interactive Menu to select the "Setting menu" item and press ENTER (3).
- Select the "DRL" item and press ENTER (3).
- Select the "DRL" item and press ENTER (3).

"Auto" and "Manual" are displayed in the middle. While the currently set mode is shown on the right. Use buttons (1) and (2) to scroll and select the desired mode. Press ENTER (3) to confirm.

Note

In case of battery disconnection, the "Auto" mode is automatically set.

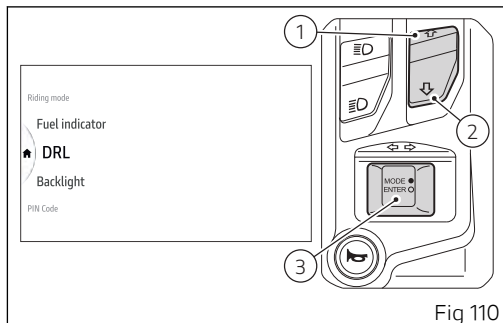

Fig 110

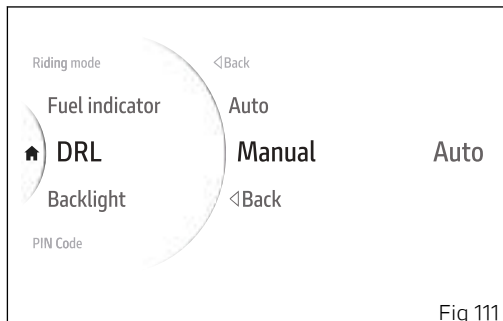

Fig 111

Setting menu - Backlight

This function allows setting the display day or night mode.

- Use buttons (1) and (2) from the Interactive Menu to select the "Setting menu" item and press ENTER (3).
- Select the "Backlight" item and press ENTER (3).

"Day", "Night" and "Auto" are displayed in the middle. While the current status of the function is shown on the right.

The "Auto" mode allows the background colour to automatically change according to the ambient light detected by the instrument panel.

Use buttons (1) and (2) to scroll and select the desired mode. Press ENTER (3) to confirm.

Note

In case of battery disconnection, the "Auto" mode is automatically set.

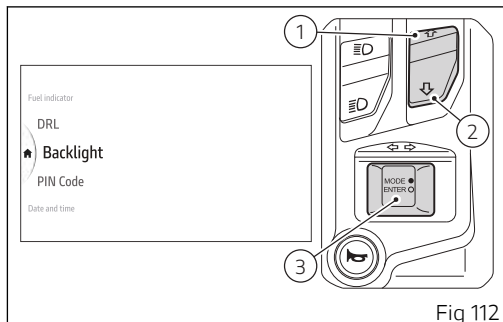

Fig 112

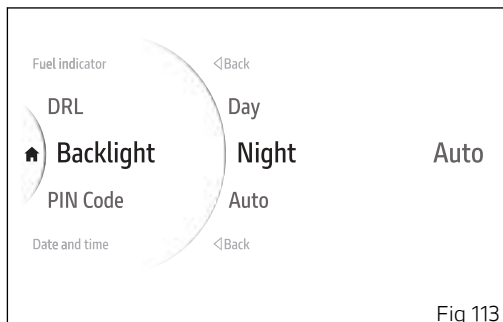

Fig 113

Setting menu - PIN Code

This function allows the user to activate or modify the PIN Code.

- Use buttons (1) and (2) from the Interactive Menu to select the "Setting menu" item and press ENTER (3).
- Select the "PIN Code" item and press ENTER.

The PIN Code is initially not present in the motorcycle and must be activated by the user by entering the 4-digit PIN in the instrument panel, otherwise the motorcycle cannot be started temporarily in the case of a malfunction.

In order to temporarily start the motorcycle in case of malfunction, please refer to the procedure called "Restoring motorcycle operation via the PIN Code".

If the PIN Code has never been activated, this menu will include "New PIN" item to activate it. While if the PIN Code has already been activated, this menu will include "Modify PIN" item, which allows modifying the already stored PIN.

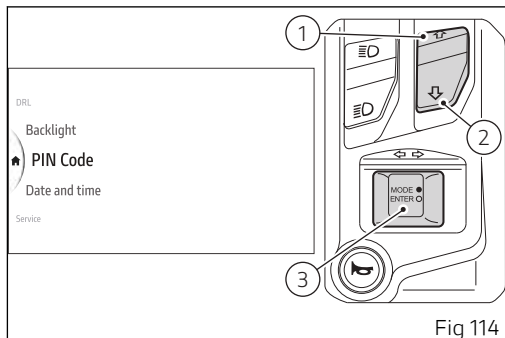

Fig 114



Attention

The PIN Code must be activated and stored by the vehicle owner. If a PIN Code is already set, please contact your Ducati authorised dealer to reset it. The Ducati authorised dealer may ask you to demonstrate that you are the owner of the motorcycle.

New PIN

- Use buttons (1) and (2) from the Interactive Menu to select the "Setting menu" item and press ENTER (3).
- Select the "PIN Code" item and press ENTER (3).
- Select the "New PIN" item and press ENTER (3).

The display shows "New PIN" on the left and the first of the 4 digits active for the entry.

Entering the code:

- The 2 arrows above and below the digit indicate that the number can be changed from 0 to 9 using buttons (1) and (2).
- Press ENTER (3) to confirm and move on to the following digit.
- Repeat the procedure until entering all 4 digits (Fig 117).

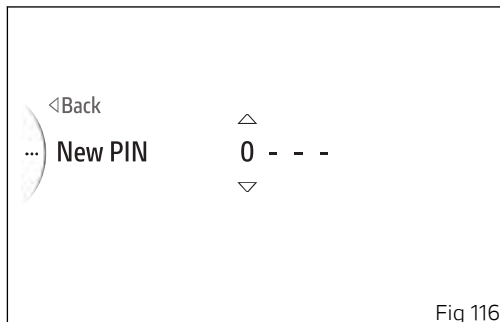
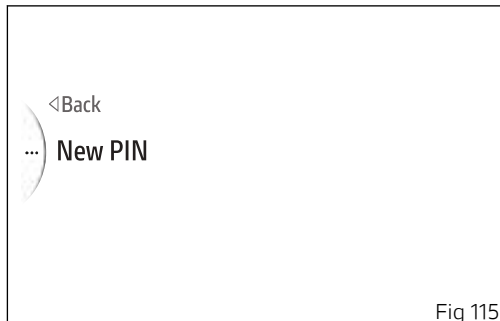

Once the last digit has been confirmed, "Save" is displayed.
Press ENTER to confirm, "Saved" is then displayed for a few seconds.
The instrument panel returns to the previous screen displaying "Modify PIN" instead of "New PIN" (Fig 119).

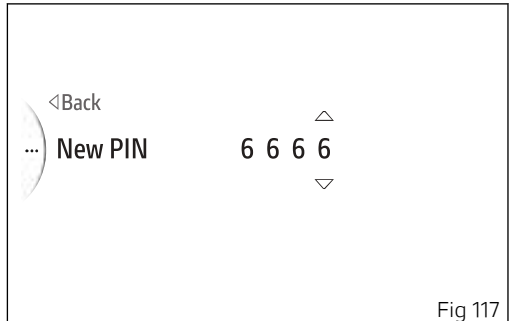

Fig 117

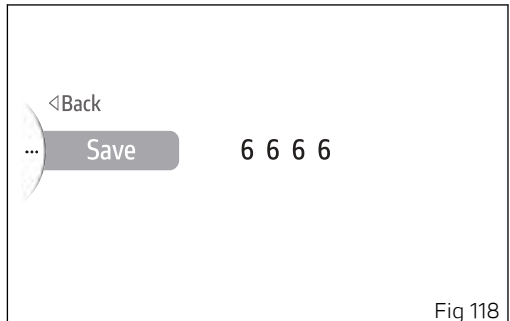

Fig 118

Modify PIN

- Use buttons (1) and (2) from the Interactive Menu to select the "Setting menu" item and press ENTER (3).
- Select the "PIN Code" item and press ENTER (3).
- Select the "Modify PIN" item and press ENTER (3).

The display shows "Current PIN" on the left and the first of the 4 digits active for the entry.

Entering the code:

- The 2 arrows above and below the digit indicate that the number can be changed from 0 to 9 using buttons (1) and (2).
- Press ENTER (3) to confirm and move on to the following digit.
- Repeat the procedure until entering all 4 digits.

Once the fourth digit is entered, press ENTER (3) and the instrument panel behaviour will be as follows:

- If the entered PIN is correct, the display shows "Correct".
- If the PIN entered is incorrect, "Wrong" is displayed and a new attempt to enter the current PIN can be made.

If the PIN is correct, enter the new PIN.

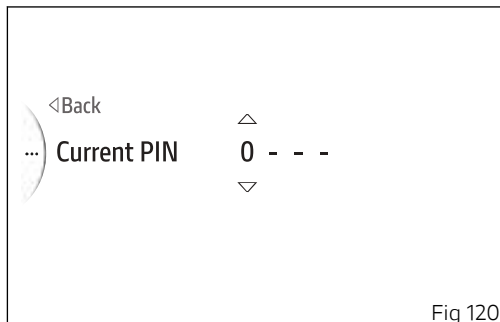
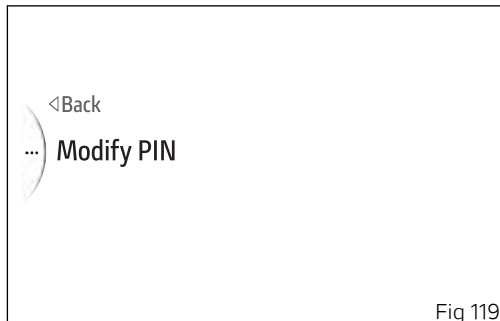

The display shows “New PIN” on the left and the first of the 4 digits active for the entry (Fig 116).

Entering the code:

- The 2 arrows above and below the digit indicate that the number can be changed from 0 to 9 using buttons (1) and (2).
- Press ENTER (3) to confirm the digit and move on to the following one.
- Repeat the procedure until entering all 4 digits (Fig 117).

Once the last digit has been confirmed “Save” (Fig 118) is displayed.

Press ENTER (3) to confirm, “Saved” is then displayed for a few seconds and the instrument panel returns to the previous screen.

Setting menu - Date and time

This function allows setting date and time.

- Use buttons (1) and (2) from the Interactive Menu to select the "Setting menu" item and press ENTER (3).
- Select the "Date and time" item and press ENTER (3).

The items "Set date" and "Set time" (Fig 122) are displayed.

With buttons (1) and (2) it is possible to scroll through and select the parameter to be set. Press ENTER (3) to confirm.

Note

If the date or time have never been set, a string of dashes "-" is displayed instead of the corresponding values.

Date and time must be set again after battery disconnection.

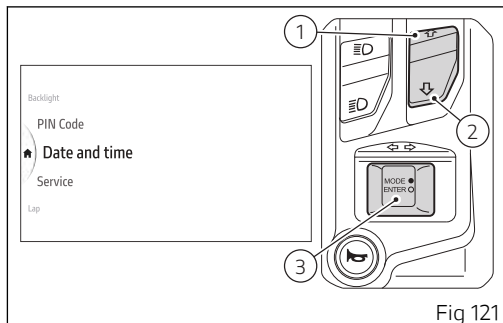

Fig 121

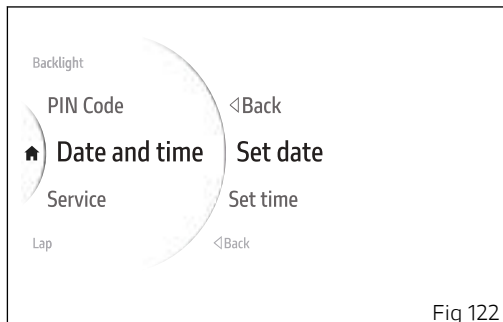

Fig 122

Date setting

The "Set date" function allows setting the date.

- Use buttons (1) and (2) from the Interactive Menu to select the "Setting menu" item and press ENTER (3).
- Select the "Date and time" item and press ENTER (3).
- Select the "Set date" item and press ENTER (3).

The first parameter of the date (Fig 124) starts flashing and is displayed with two arrows placed above and below it; the available values for the selected parameter are also displayed. Use buttons (1) and (2) to scroll and select the desired value. Press ENTER (3) to confirm and move on to the following parameter.

When confirming the last parameter:

- if the just entered date is not valid, "Wrong" is displayed for 3 seconds and then you can enter the correct date again;
- if the just entered date is correct, press ENTER (3) to exit.

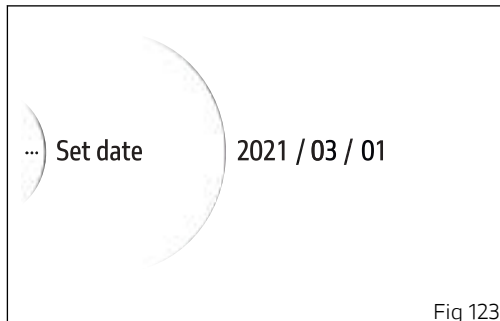

Fig 123

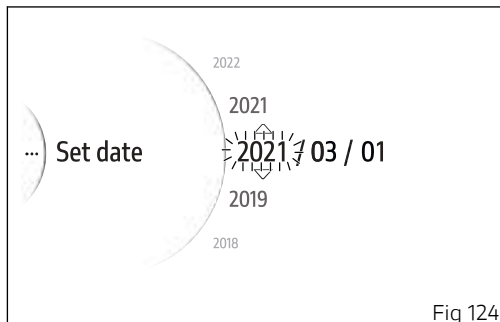

Fig 124

Setting the time

The "Set time" function allows setting the time.

- Use buttons (1) and (2) from the Interactive Menu to select the "Setting menu" item and press ENTER (3).
- Select the "Date and time" item and press ENTER (3).
- Select the "Set time" item and press ENTER (3).

The hour number becomes flashing and is displayed with two arrows placed above and below it; the available values are also displayed (Fig 126). Use buttons (1) and (2) to scroll and select the desired value. Press ENTER (3) to confirm and move on to the following parameter.

After setting the time, press ENTER (3) to exit.

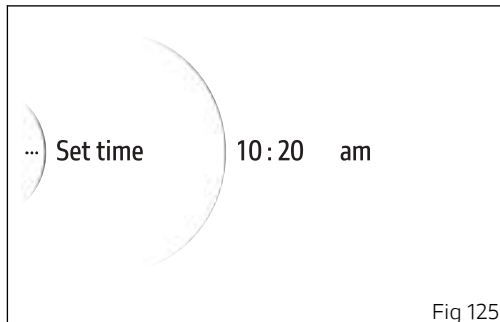

Fig 125

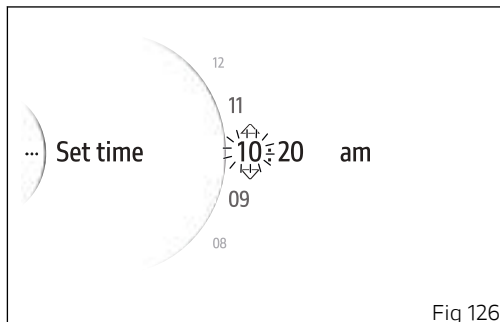

Fig 126

Setting menu - Service

This function allows displaying the next due services.

- Use buttons (1) and (2) from the Interactive Menu to select the "Setting menu" item and press ENTER (3).
- Select the "Service" item and press ENTER (3).

The display shows the information concerning the following service types:

- 1) Oil service (remaining kilometres or miles)
- 2) Valve Clearance Check Service (remaining kilometres or miles)
- 3) Annual service (date)

Note

This function does not allow changes to be made.

The First Service 1000 must be carried out after the first 1,000 km/600 mi;

The Oil Service  must be carried out every 15,000 km/9,000 mi;

The Desmo Service (Valve Clearance Check Service)  must be carried out every 30,000 km/18,000 mi;

The Annual Service  must be carried out every 12 months.

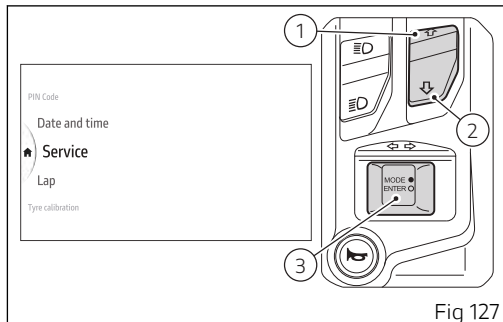

Fig 127

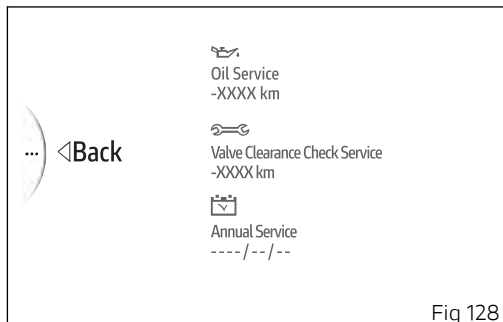

Fig 128

Service warnings

This indication shows the user that the motorcycle is due for service and must be taken to a Ducati Authorised Service Centre.

The service warning indication can be reset only by the Ducati Authorised Service Centre during servicing.

Service coupon types are: "Oil service", "Valve Clearance Check Service" and "Annual service".

Service coupon deadline warnings are displayed in 2 modes: big (A) and small (B).

When the thresholds set for service coupons are close, the instrument panel activates the following grey warnings for 5 seconds upon each Key-On, showing the remaining distance or days: for "Oil service" (Fig 129) and "Valve Clearance Check Service" it is activated 1000 km (621 miles) before service is due, for "Annual service" 30 days before service is due.

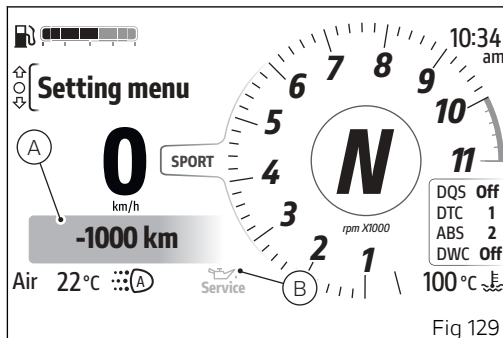

The image (Fig 130) shows the large version on the left and the small version of the relevant service coupons on the right.

Once the threshold of the service coupons has been reached and upon every Key-On, the corresponding amber yellow signal is activated in large mode (A, Fig 129) for 5 seconds, then the signal toggles to small mode (B, Fig 129): "Oil service" (C), "Valve Clearance Check Service" (D), "Annual service" (E). Amber yellow service warning is displayed until reset by the Ducati authorised service centre, during maintenance.

Digital Maintenance

At the pre-set deadlines, it will be necessary to contact your Dealer who will carry out the maintenance scheduled for the deadline indicated on the instrument panel.

Using the dedicated diagnosis instrument, the Dealer will confirm that the service has been performed and postpone the next due deadlines. The history of routine maintenance is saved on Ducati's servers in order to certify that it has been carried out (it is a digital maintenance booklet).

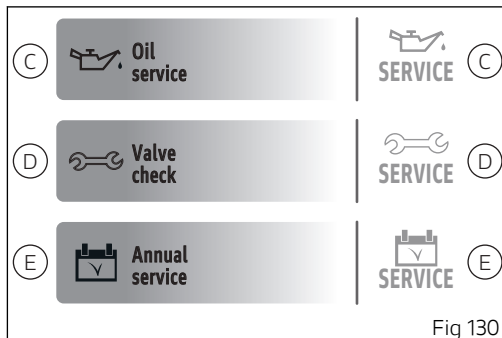

Fig 130

The bike owner will be able to see the performed services both in the MyGarage reserved area (on Ducati.com website) and in the MyDucati App.



Setting menu - Lap

This function allows enabling or disabling the Lap function and view and delete the recorded LAPs.

- Use buttons (1) and (2) from the Interactive Menu to select the "Setting menu" item and press ENTER (3).
- Select the "Lap" item and press ENTER (3).

The following items are displayed: "On", "Off", "Lap data" and "Erase data" (visible only if laps have previously been recorded). The currently set function status is shown on the right (Fig 132).

"On" and "Off" items are used to activate and deactivate the Lap function, respectively. The "Lap data" item allows viewing the saved laps, while the "Erase data" item allows deleting the recorded laps. Use buttons (1) and (2) to scroll and select the desired item. Press ENTER (3) to confirm.

Note

Activation and deactivation can also be done directly from the "Lap" function in the Interactive Menu.

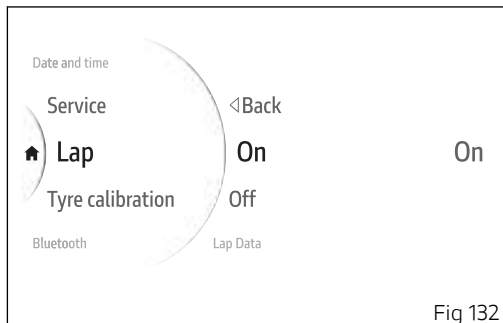
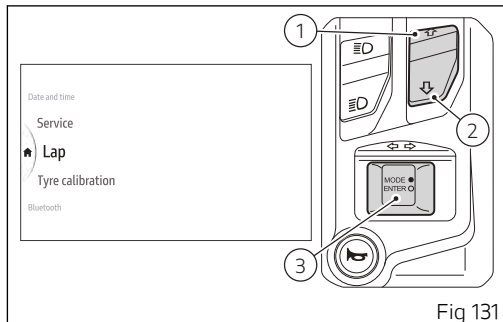

Lap data

This function allows viewing the data of each recorded Lap.

- Use buttons (1) and (2) from the Interactive Menu to select the "Setting menu" item and press ENTER (3).
- Select the "Lap" item and press ENTER (3).
- Select the "Lap data" item and press ENTER (3).

Saved laps (maximum 30 laps) and the "Best lap" item are displayed on the left-hand side, while data recorded for the single lap are displayed in the middle:

- Time
- Maximum reached speed
- Maximum reached rpm
- Maximum leaning angle
- Maximum yaw angle

Use buttons (1) and (2) to scroll through the laps in the list and to view their recorded data. Select "Best Lap" option to view best lap time data.



Note

If there are no memorised laps, when accessing this menu the instrument panel will show No lap.

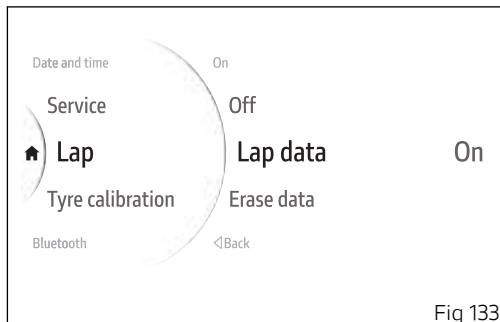

Fig 133

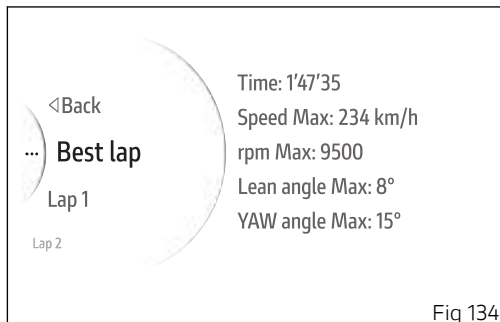

Fig 134

Erase data

This item is only displayed if laps have previously been recorded.

- Use buttons (1) and (2) from the Interactive Menu to select the "Setting menu" item and press ENTER (3).
- Select the "Lap" item and press ENTER (3).
- Select the "Erase data" item and press ENTER to erase the data.

The message "Wait..." is then displayed for a few seconds (Fig 136), followed by the message "Erased" for a few seconds. The previous screen will then be displayed without the "Erase data" item.

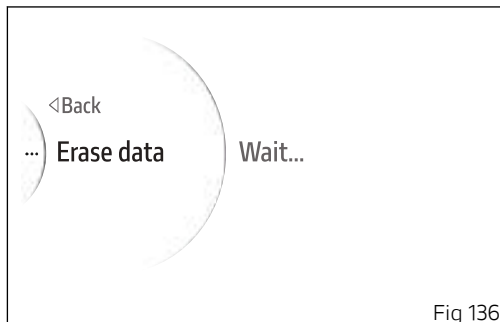
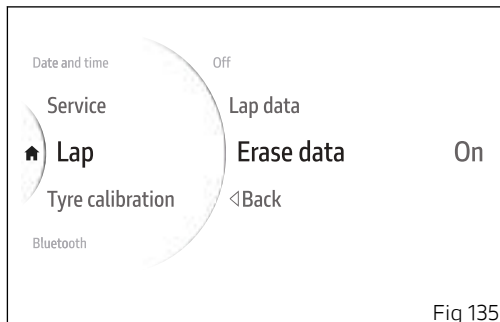

Setting menu - Tyre calibration

This function allows the user to run the procedure for calibrating and teaching in the tyre rolling circumference or to restore their original values.

- Use buttons (1) and (2) from the Interactive Menu to select the "Setting menu" item and press ENTER (3).
- Select the "Tyre calibration" item and press ENTER (3).

If a tyre calibration has never been carried out, "Start" is displayed.

If a calibration has already been carried out, "Default" is displayed instead of "Start".

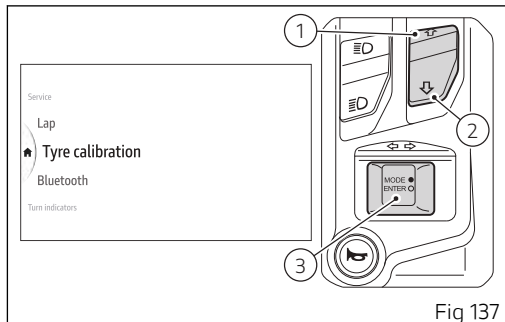

Fig 137

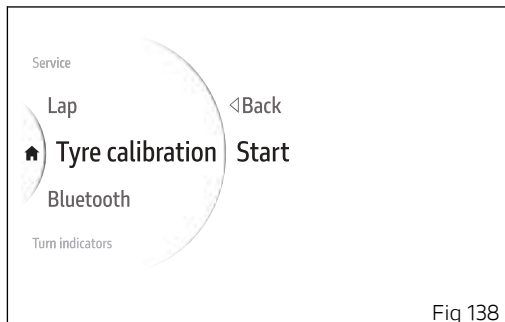

Fig 138

Start

- Enter the SETTING MENU.
- Use the navigation buttons to select "Tyre calibration" option and press ENTER button.
- Select the "Start" option and press ENTER button.

When the calibration procedure starts, the instrument panel displays the message "Ready" (A), the message "Keep Speed" with speed range and the gear to be maintained by the user to complete the teach-in procedure. On the RH side is the reference Riding Mode, current speed and gear engaged.

Important

The teach-in procedure is allowed only at a vehicle speed between 48 Km/h (30 mph) and 52 Km/h (32 mph) in the 2nd gear.

When the rider complies with the required conditions of speed and gear indicated, the instrument panel starts system calibration: all previous information will be displayed showing "In progress" instead of "Ready". Calibration is performed by keeping speed and gear within the indicated range for 5 seconds.

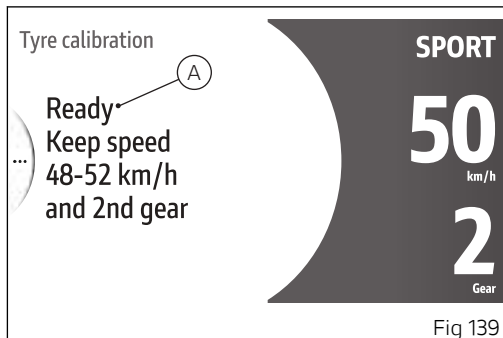

The procedure can be aborted by holding depressed the button (1) for a long time: in this case the instrument panel shows all previous information, replacing message "In progress" with message "Aborted", followed by the previous menu after a few seconds.

If the teach-in procedure is completed correctly, the instrument panel shows "Completed" (B) followed by the previous menu after a few seconds.

If an error or malfunction occurs during the calibration procedure, the instrument panel shows "Failed" followed by the previous menu after a few seconds.



Note

During the calibration procedure, the procedure will stop if the vehicle speed exceeds 100 km/h (62 mph) or the key is turned off.

Default

- Enter the SETTING MENU.
- Use the navigation buttons to select "Tyre calibration" option and press ENTER button.
- Select the "Default" option and press ENTER button to restore default values.
- The message "Default Please Wait.." is displayed and after a while "Default Ok" for 2 seconds, then followed by the previous menu.

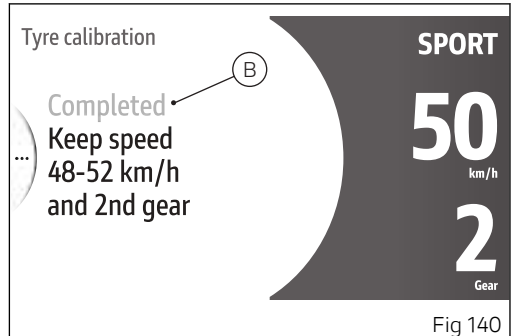

Setting menu - Turn indicators

This function allows user to set the turn indicators to automatic mode or manual mode.

The turn indicator automatic switch-off strategy is implemented based on calculation of leaning angle, vehicle speed and run distance.

- Use buttons (1) and (2) from the Interactive Menu to select the "Setting menu" item and press ENTER (3).
- Select the "Turn indicators" item and press ENTER (3).

"Auto-off" and "Manual-off" are displayed in the middle. While the current status of the function is shown on the right.

Use buttons (1) and (2) to scroll and select the desired status. Press ENTER (3) to confirm.

Note

In case of battery disconnection, the automatic mode is set.

Automatic switch-off:

The turn indicators switch off automatically after the turn, as calculated based on vehicle speed, lean angle and in general according to the analysis of vehicle dynamic conditions.

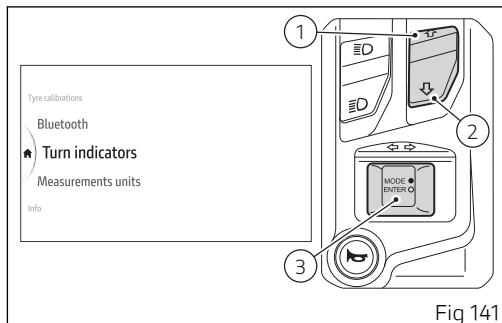

Fig 141

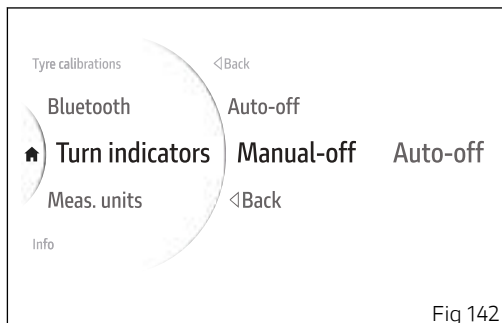

Fig 142

This means that automatic switch-off is triggered when vehicle speed exceeds 20 km/h (12.4 mph) after the turn indicator button was pressed.

Turn indicators also switch off automatically if they remained on for a long mileage (which can range between 200 and 2000 metres (656–6562 feet), depending on vehicle speed when the turn indicator button was pressed.

If the turn indicator switch is again operated, while turn indicator is still on, automatic switch-off feature is re-initialised.

Setting menu - Measurement units

This function allows setting the units of measurement used by the instrument panel.

- Use buttons (1) and (2) from the Interactive Menu to select the "Setting menu" item and press ENTER (3).
- Select the "Measurement Units" item and press ENTER (3).

The following items are displayed in the middle: "Speed", "Temperature", "Consumption" and "Default" (visible only if one or more measurement units have been changed). The measurement unit currently set for the selected item is shown on the right.

Use buttons (1) and (2) to scroll and select the desired item. Press ENTER (3) to access the setting page.

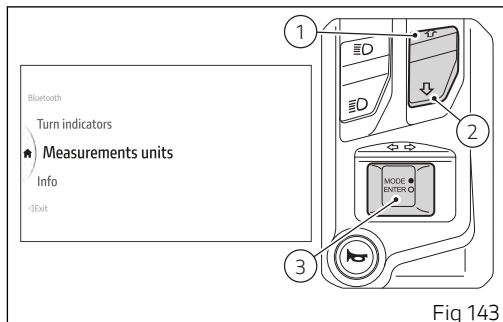

Fig 143

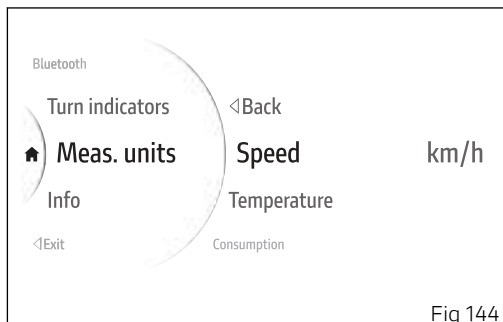

Fig 144

Speed

To set the speed measurement unit:

- Use buttons (1) and (2) from the Interactive Menu to select the "Setting menu" item and press ENTER (3).
- Select the "Measurement Units" item and press ENTER (3).
- Select the "Speed" item and press ENTER (3) (Fig 144).

Options "km/h", "mph" and "Default" are listed (visible only if the measurement unit has been previously changed). The currently set unit of measurement is shown on the right-hand side of the display.

Use buttons (1) and (2) to scroll and select the desired item. Press ENTER (3) to confirm and return to the previous screen.

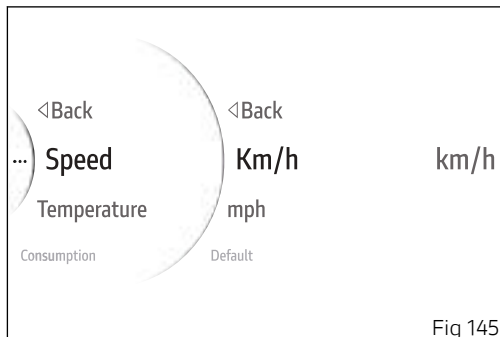

Fig 145

Temperature

To set the temperature measurement unit:

- Use buttons (1) and (2) from the Interactive Menu to select the "Setting menu" item and press ENTER (3).
- Select the "Measurement Units" item and press ENTER (3).
- Select the "Temperature" item and press ENTER (3).

Options "°C", "°F" and "Default" are listed (visible only if the measurement unit has been previously changed). The currently set unit of measurement is shown on the right-hand side of the display. Use buttons (1) and (2) to scroll and select the desired item. Press ENTER (3) to confirm and return to the previous screen.

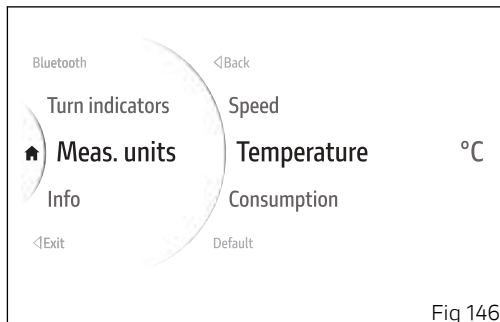

Fig 146

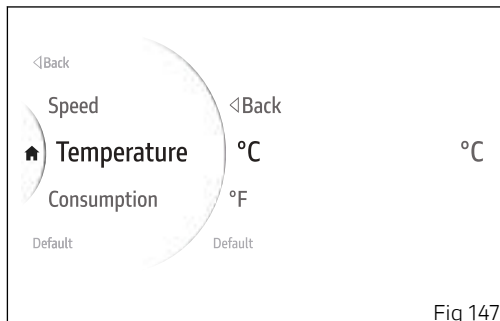

Fig 147

Consumption

To set the consumption measurement unit:

- Use buttons (1) and (2) from the Interactive Menu to select the "Setting menu" item and press ENTER (3).
- Select the "Measurement Units" item and press ENTER (3).
- Select the "Consumption" item and press ENTER (3).

Options "L/100", "km/l", "mpg UK", "mpg US" and "Default" are listed (visible only if the measurement unit has been previously changed). The currently set unit of measurement is shown on the right-hand side of the display.

Use buttons (1) and (2) to scroll and select the desired item. Press ENTER (3) to confirm and return to the previous screen.

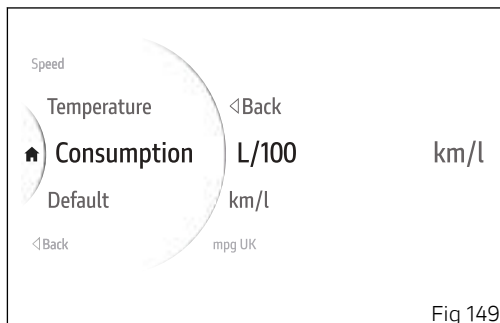
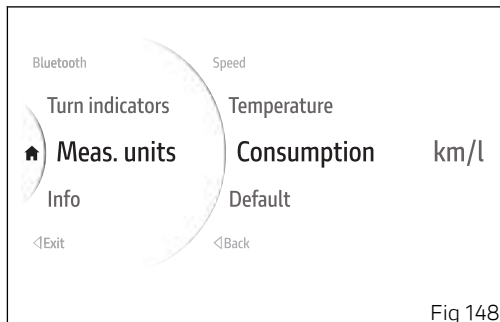

Restoring the unit of measurement

You can restore all or a single unit of measurement.

To restore all measurement units:

- Use buttons (1) and (2) from the Interactive Menu to select the "Setting menu" item and press ENTER (3).
- Select the "Measurement Units" item and press ENTER (3).
- Select the "Default" item and press ENTER (3). The instrument panel displays "Wait..." for a few seconds followed by "Default restored", then "Default" disappears from the menu list.

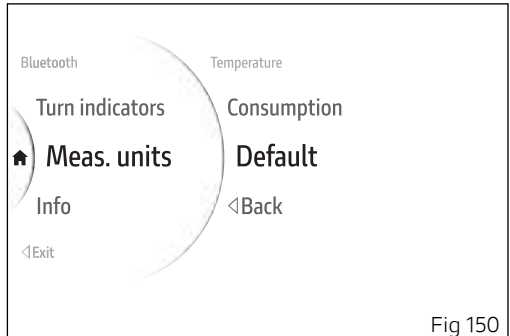
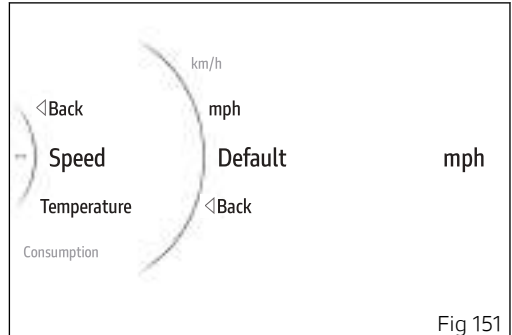

Fig 150

To restore a single unit of measurement:

- Use buttons (1) and (2) from the Interactive Menu to select the "Setting menu" item and press ENTER (3).
- Select the "Measurement Units" item and press ENTER (3).
- Select the value to be restored (e.g. speed) and press ENTER (3).
- Select the "Default" item and press ENTER (3). The instrument panel displays "Wait..." for a few seconds followed by "Default restored", then "Default" disappears from the menu list.



Setting menu - Info

This function allows displaying the next due services.

- Use buttons (1) and (2) from the Interactive Menu to select the "Setting menu" item and press ENTER (3).
- Select the "Info" item and press ENTER (3).

The display shows the information concerning the battery and engine rpm in a digital format. Press the ENTER button (3) to quit.



Note

This function does not allow changes to be made.

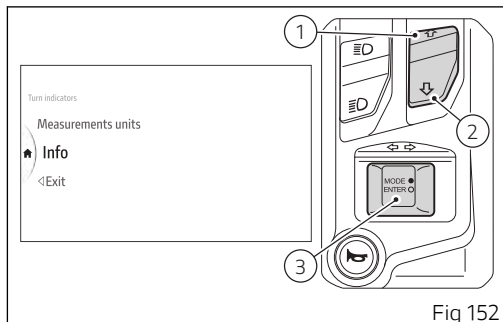

Fig 152

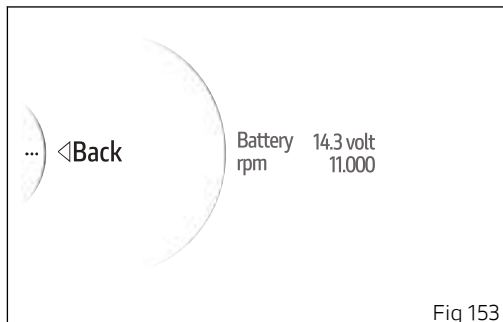

Fig 153

Warning displaying

The instrument panel manages a number of warnings and alarms, aimed at giving useful information to the rider during use.

Upon key-on, if there are any active warnings, the instrument panel will display the messages for all the present warnings or alarms: in a large size (A) for the first 5 seconds and then in a smaller size (B). When several warnings or alarms are active, they are displayed in a sequence, one every 3 seconds.

In the following figures, the warnings are shown on the left in the large version and on the right in the small version.

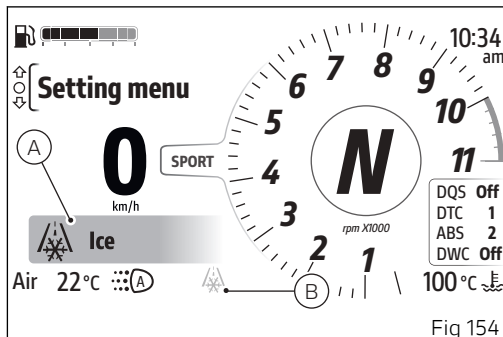

Ice (C, Fig 155)

Yellow, it means that there might be ice on the road, due to a low temperature. Warning is activated when the instrument panel detects a temperature of 4°C (39°F) or lower than that. Warning will be disabled as soon as temperature rises up to 6°C (43°F).

Attention

This warning does not exclude the fact that there may be some ice on the road also if temperature is higher than 4 °C (39 °F). When the temperature is low, it is recommended to always ride with great care, especially on path sections not under the sun and/or bridges.

Set date (D, Fig 155)

The yellow colour indicates that the date must be entered using the "Date and time" function in the "Setting menu" (page 152).

Low battery (E, Fig 155)

Red, it indicates that the vehicle battery voltage is low, i.e. lower than or equal to 11.0V.

Ducati recommends charging battery in the shortest delay using the special instrument as engine could not be started.

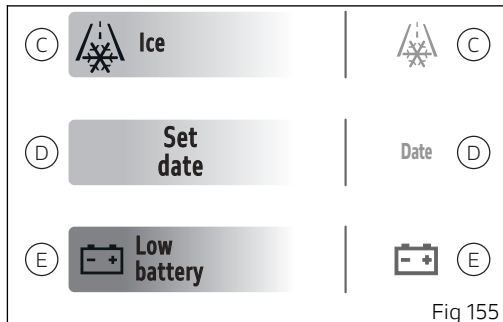

Reserve (F, Fig 156)

Yellow, it indicates that the fuel level is low. There is no small version of the warning.



Note

When the fuel is low, the relevant indicator is forced in the remaining km or mile mode.

ABS Front only (G, Fig 156)

Yellow indicates that the level set for ABS makes it active on the front wheel only. To change the ABS level, refer to chapter "Setting menu - Riding Mode - ABS" (page 131). There is no big version of the warning.

Error warnings

The instrument panel manages error warnings in order to allow the rider to identify any abnormal motorcycle behaviour in real time.

If there is an error, the instrument panel shows the indication in red on the main screen, in large format (A) for the first 10 seconds and then in small format (B).

The warning then remains active until the error is resolved.

When several errors are active, they are displayed in a sequence, one every 5 seconds.

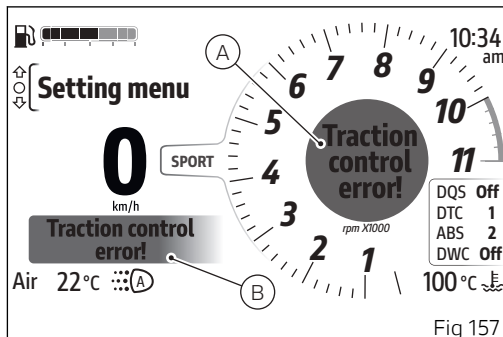

Traction control error! (Fig 158)

Activation of this error indicates that it is necessary to go to a Ducati Authorised Service Centre as the vehicle Traction Control is in error.

ABS error! (Fig 159)

Activation of this error indicates that it is necessary to go to a Ducati Authorised Service Centre as the vehicle ABS is in error.

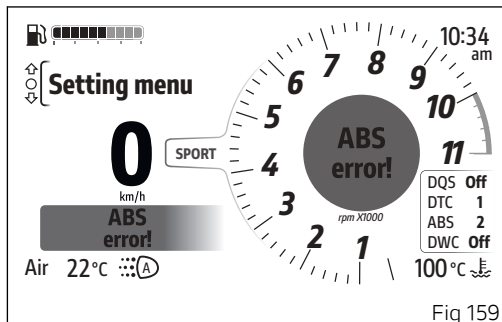
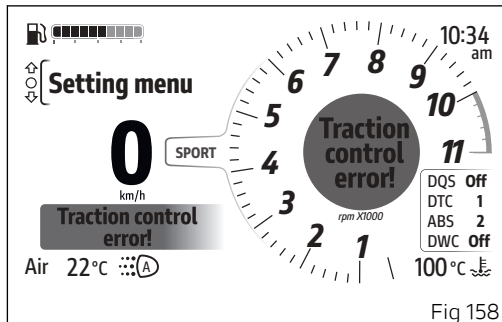

Main use and maintenance operations

Checking coolant level and topping up, if necessary

Check coolant level in the expansion reservoir on the right side of the motorcycle, near the fuse boxes, according to the intervals indicated in the tables in the chapter "Scheduled maintenance chart".

Position the vehicle on level ground, on the side stand.

Check that the level is between the "MIN" (minimum) and "MAX" (maximum) marks on the expansion reservoir cover. If the level is below the "MIN" mark have it topped up at a Ducati Dealer or Authorised Service Centre.



Attention

This operation must be performed with cold engine. Failure to observe the above recommendation may lead to coolant or hot vapour leakage with possible consequent severe burns.

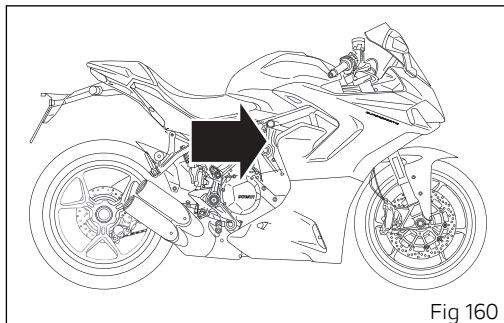

Fig 160

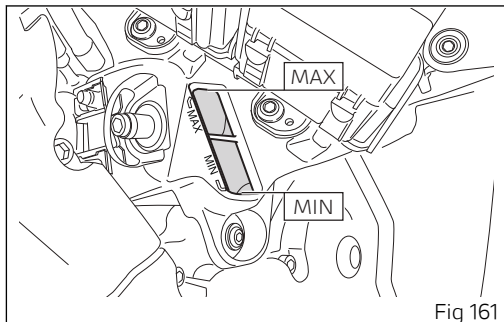

Fig 161

Check clutch and brake fluid

Check the brake and clutch fluid level with the vehicle in a vertical position and on a flat surface. The levels should not fall below the MIN notch on the respective front brake (1), rear brake (2) and clutch (3) reservoirs.

If level drops below the limit, air might get into the circuit and affect the operation of the system involved.

Brake and clutch fluid must be topped up and changed at the intervals specified in the scheduled maintenance chart under "Scheduled maintenance"; please contact a Ducati Dealer or Authorised Service Centre.

Brake system

If you find exceeding clearance on brake lever or pedal and brake pads are still in good condition, contact your Ducati Dealer or authorised Service Centre to have the system inspected and any air drained out of the circuit.

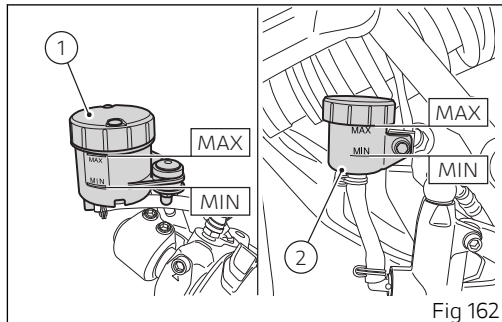

Fig 162

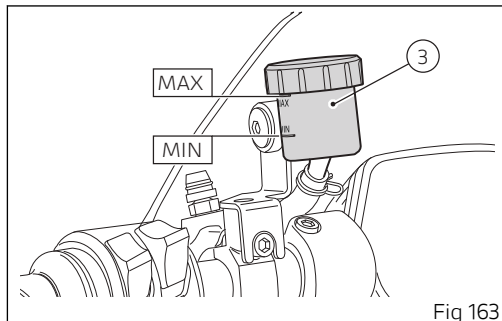

Fig 163



Attention

Brake and clutch fluid can damage paintwork and plastic parts, so avoid contact. Hydraulic fluid is corrosive; it may cause damage and lead to severe injuries. Never mix fluids of different qualities. Check seals for proper sealing.

Clutch system

If the control lever has exceeding clearance and the transmission snatches or jams as you try to engage a gear, it means that there might be air in the circuit. Contact your Ducati Dealer or authorised Service Centre to have the system inspected and air drained out.



Attention

Clutch fluid level will increase as clutch plate friction material wears down. Do not exceed the specified level (3 mm (0.12 in) above the minimum level).

Checking brake pads for wear

Check brake pads wear through the inspection hole in the callipers.

Change both pads if friction material thickness of even just one pad is about 1 mm (0.04 in).

Attention

Friction material wear beyond this limit would lead to metal support contact with the brake disc thus compromising braking efficiency, disc integrity and rider safety.

Important

Have the brake pads replaced at a Ducati Dealer or authorised Service Centre.

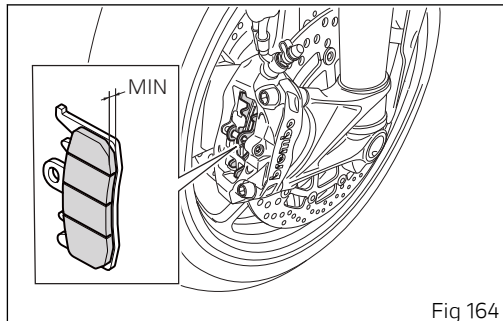

Fig 164

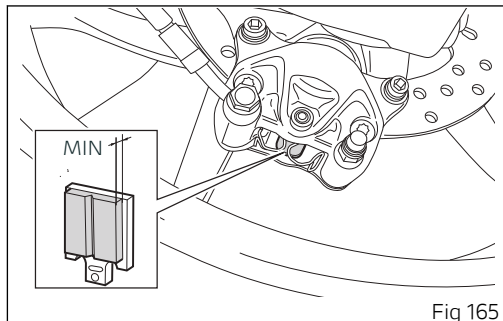

Fig 165

Charging the battery



Note

The positive pole is protected by a removable cover.



Attention

Have the battery removed at a Ducati Dealer or authorised Service Centre.

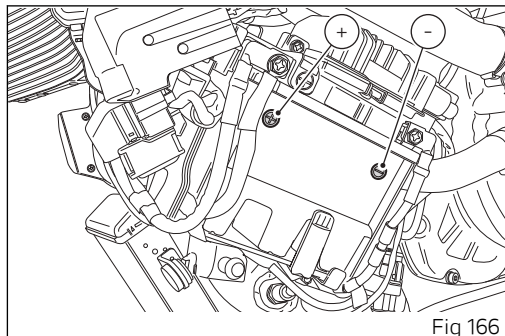

Fig 166

Checking drive chain tension

Important

Have chain tension adjusted by a Ducati Dealer or authorised Service Centre.

Make the rear wheel turn until you find the position where chain is tightest. Set the motorcycle on the side stand. With just a finger, push down the chain at the indicated point of measurement and release.

Measure the distance (A) between the centre of the chain pins and the aluminium section of the swinging arm. It must be: $A = 35 \div 37$ mm (1.38 \div 1.46 in).

Important

This only applies to the motorcycle STANDARD settings, available upon delivery.

Important

If drive chain is too tight or slack, adjust tension so as to bring values back to the specified range.

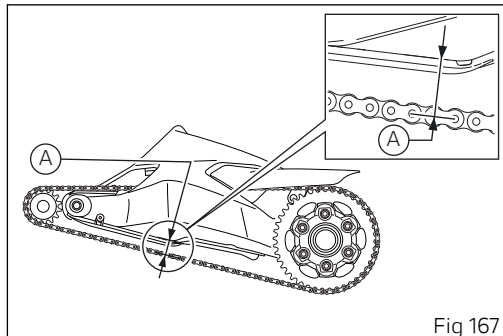
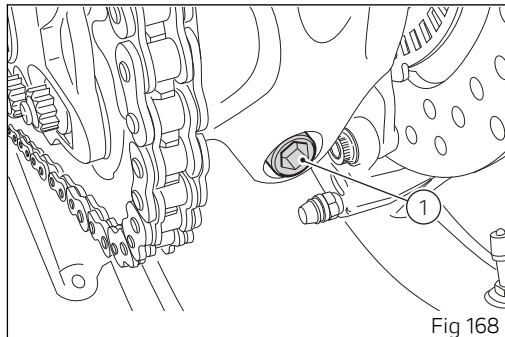

Fig 167

⚠ Attention
Correct tightening of swinging arm screw (1) is critical to rider and passenger safety.

⚠ Important
Improper chain tension will lead to early wear of transmission parts.

⚠ Important
To ensure the best performance and long life of the chain, please follow the information related to chain cleaning, lubrication, inspection and tensioning.



Lubricating the drive chain

! Important

Have drive chain cleaned by a Ducati Dealer or authorised Service Centre.

! Attention

Carry out these inspection operations with the engine off, the vehicle at a standstill, on a flat ground and on the stand.

Cleaning

Before proceeding with the chain lubrication it is important to correctly wash and clean it. The chain cleaning is extremely important for its duration. In fact, it is necessary to remove any mud, soil, sand or dirt from the chain first using a soft damp cloth (1) to soften the most resistant dirt and then with a jet of water and then dry it immediately using compressed air at a distance of at least 30 cm (11.81 in).

Checking the chain

The chain fitted on your motorcycle has O-rings that keep dirt out of and lubricant inside the sliding parts.

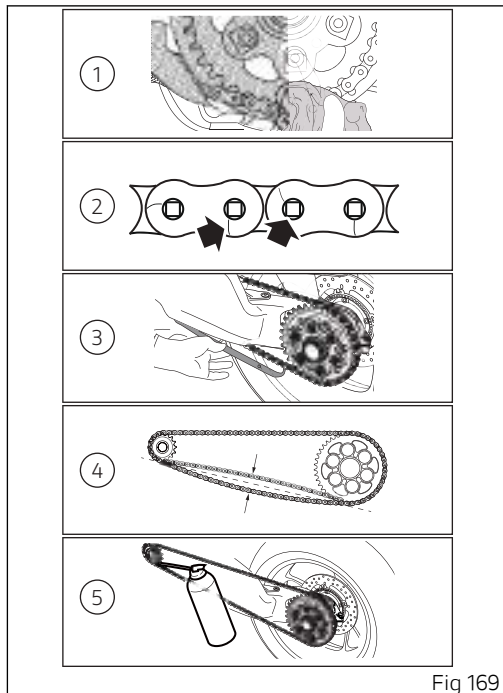

Fig 169

Check the chain for wear by checking the links at the points indicated (2).

Attention

Avoid the use of steam, fuel, solvents, hard brushes or other methods that could damage the O-rings; also avoid direct contact with the battery acid as it could cause mini cracks in the links as shown in the figure.

Attention

In particular, in case of Off-Road use of the bike, it is possible that excessive wear of the links occurs due to the contact with the chain sliding shoe; friction could in fact cause the chain to overheat, altering the heat treatment of the links and making them particularly fragile.

Checking the sliding shoe

Check the wear of the sliding shoe (3) and, if necessary, contact a Ducati Dealer or Authorised Service Centre.

Checking the tension

Check the chain tension (4) as indicated in the subsection "Checking the drive chain tension".

Have the chain tension adjusted by a Ducati Dealer or authorised Service Centre.

Lubrication



Important

Have drive chain cleaned by a Ducati Dealer or authorised Service Centre.



Attention

Use SHELL Advance Chain to lubricate the chain; the use of non-specific lubricants could damage the O-rings and therefore the entire drive system.

It is recommendable to lubricate the chain without waiting for it to cool down after using the motorcycle, so that the new lubricant can penetrate better between the inner and outer links and be more effective in its protective action.

Place the bike on the rear paddock stand. Make the rear wheel turns fast in the opposite direction to the direction of travel.

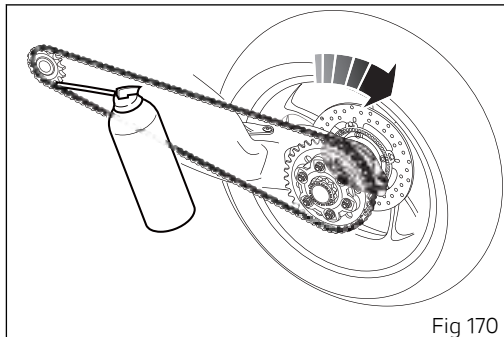
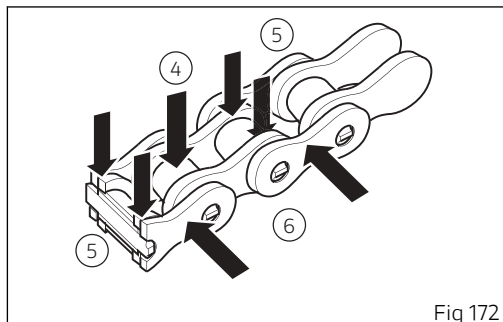
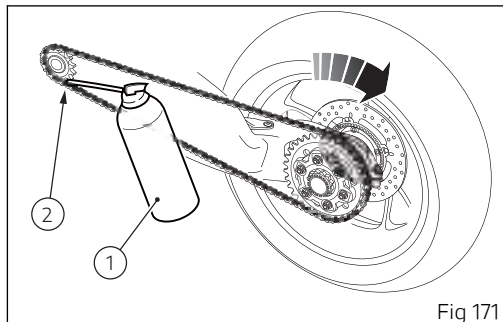

Fig 170

Apply the lubricant jet (1) inside the chain between the inner and outer links, in point (2) immediately before the engagement point on the sprocket.

Due to the centrifugal force, the lubricant, made fluid by the solvents contained in the spray, will expand in the working area between the pin and the bush, ensuring perfect lubrication.

Repeat the operation by aiming the lubricant jet to the central part (5) of the chain so as to lubricate the rollers (4), and to the outer plates (6) as shown in the figure.



After lubrication, wait 10-15 minutes to allow the lubricant to act on the internal and external surfaces of the chain and then remove the excess lubricant with a clean cloth.

⚠ Important

Do not use the motorcycle immediately after lubricating the chain as the lubricant, still fluid, would be centrifuged outwards causing possible soiling of the rear tyre or the rider's footpeg.

⚠ Important

Check the chain often, taking care to lubricate it, as also indicated in the table below: at least every 1000 km (621 mi) or more frequently (about every 400 km (248 mi)) when using the bike with high outside temperatures (40°C) or after long travels on the highway at high speed.

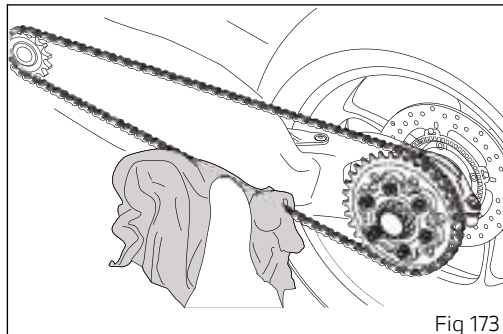

Aligning the headlight

Check correct headlight aiming. Position the motorcycle 10 metres from a wall or a screen, the motorcycle must be perfectly upright with the tires inflated to the correct pressure and with a rider seated, perfectly perpendicular to the longitudinal axis. On the wall or surface, draw a horizontal line at the same height from the ground as the centre of the headlight and a vertical line aligned with the longitudinal axis of the motorcycle. If possible, perform this check in dim light. Switch on the low beam. The height of the upper limit between the dark area and the lit area must not be more than $\frac{9}{10}$ of the height from the ground of the headlight centre.



Note

This is the procedure specified by Italian regulations for checking the maximum height of the light beam. Please adapt said procedure to the provisions in force in your own country.

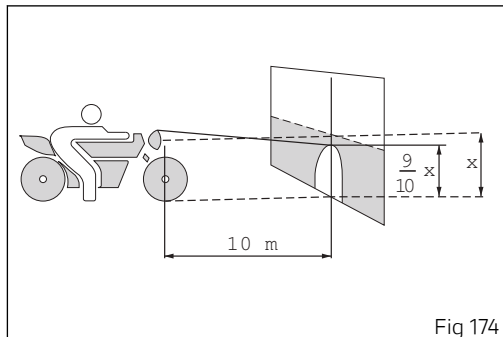

Fig 174

For the headlight vertical alignment, work on screw (1) to adjust left beam and on screw (2) to adjust the right beam.



Attention

The headlight might fog up if the motorcycle is used under the rain or after washing. Switch headlight on for a short time to dry up any condensate.

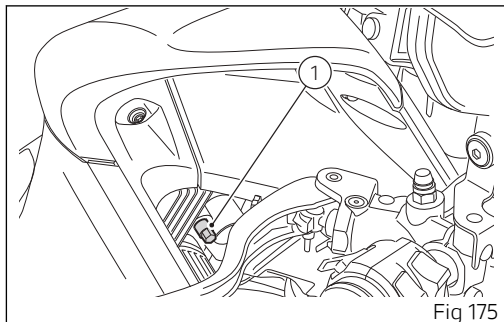

Fig 175

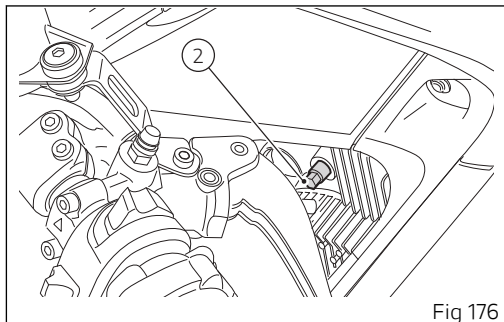
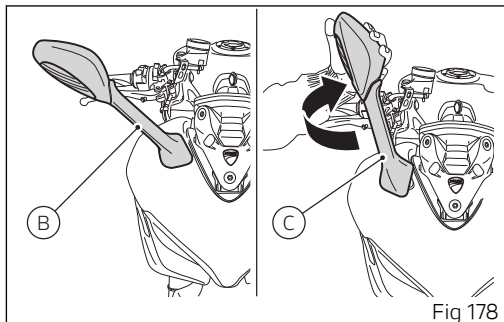
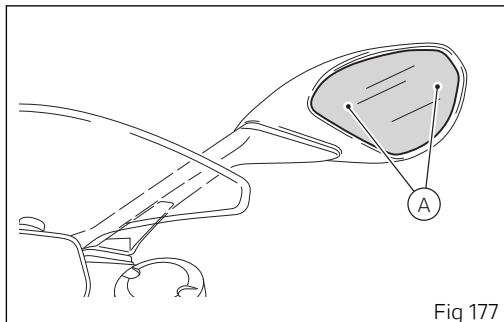

Fig 176

Adjusting the rear-view mirrors

Manually adjust the rear-view mirror by pushing at points (A).

It is possible to close the rear-view mirrors, from the open position (B), by acting on the shell and turning inwards, to the vertical position (C, closed) of the mirror.



The correct opening/closure of the rear-view mirrors is performed only by applying a force perpendicular to the rotation axis.

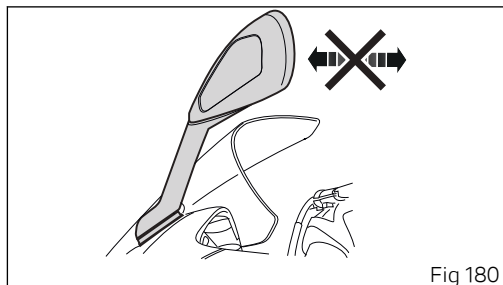

Tyres

For information on tyre type and inflation pressure, see the "Tyres" sub-section in the "Technical specifications" section.

As tyre pressure is affected by ambient temperature and altitude variations, you are advised to check and adjust it whenever you are riding in areas where ample variations in temperature or altitude occur.

Important

Check and set tyre pressure when tyres are cold. To avoid front wheel rim distortion, when riding on bumpy roads, increase tyre pressure by 0.2 ÷ 0.3 bar (2.9÷4.35 PSI).

TYRE REPAIR OR CHANGE

In the event of a tiny puncture, tubeless tyres will take a long time to deflate, as they tend to keep air inside. If you find low pressure on one tyre, check the tyre for punctures.

In case of punctured tyres, use only original equipment brands and types for the replacement. Be sure to tighten the valve caps securely to avoid leaks when riding. Never use tube type tyres. Failure to heed this warning may lead to sudden tyre bursting and to serious danger to rider and passenger.

After replacing a tyre, the wheel must be balanced.

Attention

Do not remove or shift the wheel balancing weights.

Note

Have the tyres replaced at a Ducati Dealer or authorised Service Centre. Correct removal and installation of the wheels is essential. Some parts of the ABS (such as sensors and phonic wheels) are mounted to the wheels and require specific adjustment.

Minimum tread depth

Measure tread depth (S) at the point where tread is most worn down: it should not be less than 2 mm (0.08 in), and in any case not less than the legal limit.

Important

Visually inspect the tyres at regular intervals for detecting cracks and cuts, especially on the side walls, bulges or large spots that are indicative of internal damage. Replace them if badly damaged. Remove any stones or other foreign bodies caught in the tread.

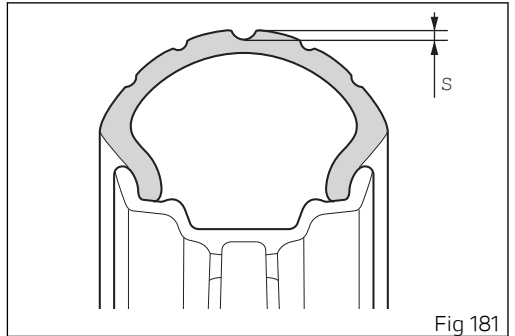

Check engine oil level

Engine oil level can be checked through the sight glass (1) on the clutch cover.

Oil level should be between the marks on the sight glass. If the level is low, top up with engine oil.

Ducati prescribes the only use of SAE 15W -50/JASO MA2 oil and recommends the use of Shell Advance 4T Ultra 15W -50 oil (JASO: MA2 and API: SN)."

Remove the oil filler cap (2) and top up until the oil reaches the required level. Refit the filler plug (2).

Important

UK VERSION: Ducati recommends you use Shell Advance DUCATI 15W-50 Fully Synthetic Oil.

Important

Engine oil and oil filters must be changed by a Ducati Dealer or authorised Service Centre at the intervals specified in the scheduled maintenance chart reported in the Warranty Card.

To check the oil level correctly, carefully follow the instructions below.

- 1) The level should be checked at warm engine, about 15 minutes after the engine has been stopped.
- 2) Turn off the engine and wait 10\15 minutes to allow the oil to flow completely inside the sump.

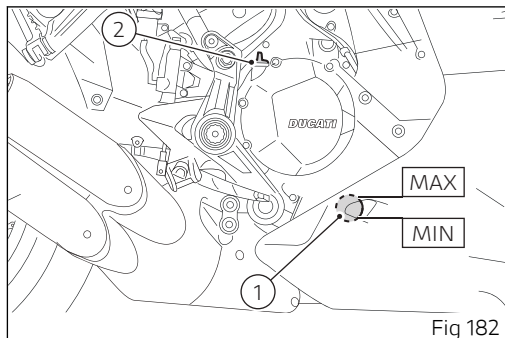

3) Position the bike with both wheels on a flat ground and in straight position.

4) Then, check the engine oil through the sight glass.
5) If the oil level is below the middle line between the MIN and MAX marks, add oil until reaching the maximum level indication.

Attention

Never exceed the MAX mark.

Recommendations concerning oil

It is recommended to use oil complying with the following specifications:

- viscosity grade SAE 15W-50;
- standard API: SN;
- standard JASO: MA2.



Attention

UK VERSION: it is recommended to use oil with viscosity grade SAE 15W-50.

SAE 15W-50 is an alphanumerical code identifying oil class based on viscosity: two figures with a W ("winter") in-between; the first figure indicates oil viscosity at low temperature; the second figure indicates its viscosity at high temperature. API (American standard) and JASO (Japanese standard) standards specify oil characteristics.

Cleaning the motorcycle

To preserve the finish of metal parts and paintwork, wash and clean your motorcycle at regular intervals, anyway according to road conditions. Use specific products only. Prefer biodegradable products. Avoid aggressive detergents or solvents.

Use only water and neutral soap to clean the Plexiglas and the seat. Periodically clean by hand all aluminium components. Use special detergents, suitable for aluminium parts. Do NOT use abrasive detergents or caustic soda.

Note

Do not use sponges with abrasive parts or steel wool: only use soft cloths.

However, the warranty does not apply to motorcycles whenever poor maintenance status is ascertained.

Important

Do not wash your motorcycle right after use. When the motorcycle is still hot, water drops will evaporate faster and spot hot surfaces.

Never clean the motorcycle using hot or high-pressure water jets.

Cleaning the motorcycle with a high pressure water jet may lead to seizure or serious faults in forks, wheel hubs, electric system, headlight (fogging), fork seals, air inlets or exhaust silencers, with consequent loss of compliance with the safety requirements.

Clean off stubborn dirt or exceeding grease from engine parts using a degreasing agent. Be sure to avoid contact with drive parts (chain, sprockets, etc.).

Rinse with warm water and dry all surfaces with chamois leather.

Attention

Braking performance may be impaired immediately after washing the motorcycle. Never grease or lubricate the brake discs to avoid losing braking power. Clean the discs with an oil-free solvent.



Attention

The headlight might fog up due to washing, rain or moisture. Switch headlight on for a short time to help and dry up any condensate.

Carefully clean the phonic wheels of the ABS in order to ensure system efficiency. Do not use aggressive products in order to avoid damaging the phonic wheels and the sensors.



Important

To clean and lubricate the drive chain, refer to the paragraph "Lubricating the drive chain".

Storing the motorcycle

If the motorcycle is to be left unriden over long periods, it is advisable to carry out the following operations before storing it away:

- clean the motorcycle;
- empty the fuel tank;
- pour a few drops of engine oil into the cylinders through the spark plug seats, then crank the engine by hand a few times so a protective film of oil will spread on cylinder inner walls;
- place the motorcycle on the service stand;
- disconnect and remove the battery.

Battery should be checked and charged whenever the motorcycle has been left unriden for over a month.

Protect the motorcycle with a suitable canvas. This will protect paintwork and prevent retaining condensate. The canvas is available from Ducati Performance.

Important notes

Laws in some countries (France, Germany, Great Britain, Switzerland, etc.) set certain noise and pollution standards.

Periodically carry out the required checks and replace parts as necessary using Ducati original spare parts to be in compliance with regulations in the given country.

Various electronic components of your vehicle have data memories that temporarily or permanently store technical information on the status, events and faults of the vehicle.

In general, this information documents the status of a component, module, system or environment.

- Operating status of system components (e.g. emission control system).
- Status messages of the vehicle and its components (e.g. wheel rotation speed, engine rpm, engaged gear, etc.)
- Malfunctions and faults of important system components (e.g. lights, brakes, etc.)
- Vehicle response in particular riding situations (e.g. traction control system, etc.)
- Environmental conditions (e.g. temperature, etc.)

These data are always of a technical nature and are used to detect and correct faults and optimise vehicle functions.

During service operations such as repairs, maintenance activities, operations under warranty, and quality assurance, service network personnel (including manufacturers) can read this technical information from the event and fault data memory using special diagnostic tools. Once the fault has been eliminated, it is possible to progressively delete or overwrite the information in the fault memory.

Vehicle data are collected as a result of a service requested by the Customer or provided under a contract (on the vehicle).

Within the scope of these services, personal data are processed in compliance with current legislation on data protection, based on a legitimate interest of Ducati to ensure increasingly efficient assistance, and finally to comply with legal obligations (e.g. information obligations on repairs and maintenance). If necessary, personal data are read and used in combination with the vehicle identification number.

Our control units do not collect geolocation data.

Vehicle transport

Before transporting the motorcycle using another vehicle, follow the safety instructions below.

- 1) Remove all loose objects and accessories from the vehicle.
- 2) Align the front wheel straight in the riding direction and lock it properly to prevent any movement.
- 3) Engage the first gear.
- 4) Use the anchoring straps and apply them to strong components (e.g. frame) and NOT on the handlebars (or handlebar, where present) or to components that could break (e.g. handgrips, rear-view mirrors, etc.).
- 5) The straps or ropes must NOT rub against any painted motorcycle components.
- 6) The suspensions, if possible, must be in a partially compressed position so as to allow less movement of the vehicle with respect to the road surface during transport.



Attention

Do NOT attach the ropes to the handlebars.

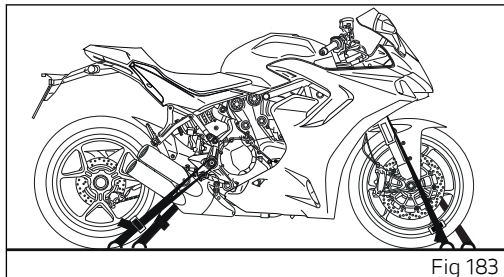

Scheduled maintenance chart

Scheduled maintenance chart: operations to be carried out by the dealer

Attention



This scheduled maintenance chart is designed for a road use. If it is used on the track, even if not during sport competitions, all parts of the motorcycle are more stressed so the routine maintenance operations must be carried out more frequently than indicated.





Attention



Please contact a Ducati Dealer or authorised Service Centre where you can receive customised service advice according to the sport use you make.



Important

Using the motorcycle under extreme conditions, such as very damp and muddy roads or dusty and dry environment, could cause above-average wear of components like the drive system, the brakes or the air filter. If the air filter is dirty, the engine could get damaged. Therefore, this might translate in required service or replacement of the wear parts earlier than specified in the scheduled maintenance chart.

	Annual Service  *			
	Desmo Service  *			
	Oil Service  *			
	First Service 1000*			
Reading of the error memory with DDS 3.0 and check of technical updates and recall campaigns on DCS	•	•	•	12
Change engine oil and filter	•	•		12
Check and clean air filter		•		12
Change air filter			•	
Change timing belts			•	60
Check and/or adjust valve clearance			•	
Change spark plugs			•	
Change coolant			•	48
Change front fork fluid	every 45000 km / 27000mi			
Visually check the front fork and rear shock absorber seals	•	•		12
Check brake and clutch fluid level (if present)	•	•		12
Change brake and clutch fluid level (if present)				24
Check front and rear brake disk and pad wear		•		12

	Annual Service  *			
	Desmo Service  *			
	Oil Service  *			
	First Service 1000*			
Check the proper tightening of brake calliper screws, brake disk screws and rear and front wheel nuts		•		12
Check rear sprocket nut tightening		•		12
Check the tightening of frame fasteners to engine, swinging arm and rear shock absorber		•		12
Check wheel hub bearings		•		12
Check the cush drive damper on rear sprocket and lubricate the rear wheel shaft			•	
Check wear of chain, chain sliding shoes, front and rear sprocket, and final drive chain elongation, tension and lubrication. Detected elongation value: _____ (cm)(in)	•	•		12
 Attention We recommend replacing the final drive chain kit within 20,000km/12,000 mi.				
Check play of steering tube bearings		•		12
Check the freedom of movement and tightening of the side stand	•	•		12

	Annual Service  *			
	Desmo Service  *			
	Oil Service  *			
	First Service 1000*			
Check that all gaiters and flexible hoses in view (e.g. fuel, brake and clutch hoses, cooling system, bleeding, drainage, etc.) are not cracked, are properly sealing and positioned	•	•		12
Check free play of rear brake lever and lubricate the levers at the handlebar and pedal controls	•	•		12
Check the free play of the cable clutch lever (where present)	•	•		12
Check tyre pressure and wear	•	•		12
Check the operation of all electric safety devices (clutch and side stand sensor, front and rear brake switches, engine kill switch, gear/neutral sensor)	•	•		12
Check lighting devices, turn indicators, horn and controls operation	•	•		12
Final test and road test of the motorcycle, testing safety devices (e.g. ABS and DTC), electric fans and idling	•	•	•	12
Visually check the coolant level and sealing of the circuit	•	•	•	12
Softly clean the motorcycle	•	•	•	12
Service coupon registration with turning off of Service warning light on instrument panel with DDS 2.0 and filling in of the on-board documentation (Service Booklet)	•	•	•	12

- * The First Service 1000 must be carried out when the 1000 km / 600 mi are reached or within 6 months.
 - * The Oil Service  must be carried out every 15,000 km / 9000 mi.
 - * The Desmo Service  must be carried out every 30,000 km / 18,000 mi.
 - * The Annual Service  must be carried out every 12 months.
- * Service operation to be carried out in accordance with the specified distance or time intervals (km, miles or months), whichever occurs first.

Scheduled maintenance chart: operations to be carried out by the customer



Important

Using the motorcycle under extreme conditions, such as very damp and muddy roads or dusty and dry environment, could cause above-average wear of components like the drive system, the brakes or the air filter. If the air filter is dirty, the engine could get damaged. Therefore, this might translate in required service or replacement of the wear parts earlier than specified in the scheduled maintenance chart.

List of operations and type of intervention [set mileage (km/mi) or time interval *]	Km. x1,000	1
	mi. x1,000	0.6
	Months	6
Check engine oil level		•
Check brake fluid level		•
Check tyre pressure and wear		•
Check the drive chain tension and lubrication		•
Check brake pads. If necessary, contact your dealer to replace components		•

*: Service operation to be carried out in accordance with the specified distance or time intervals (km, miles or months), whichever occurs first.

Technical data

Weights

Overall weight (in running order with 90% of fuel - 44/2014/EU Annex XI): 210 kg (463 lb).

Overall weight (without fluids and battery): 184 kg (406 lb).

Maximum allowed weight (carrying full load): 428 kg (943.58 lb).



Attention

Failure to observe weight limits could result in poor handling and impair the performance of your motorcycle, and you may lose control of the motorcycle.

Dimensions

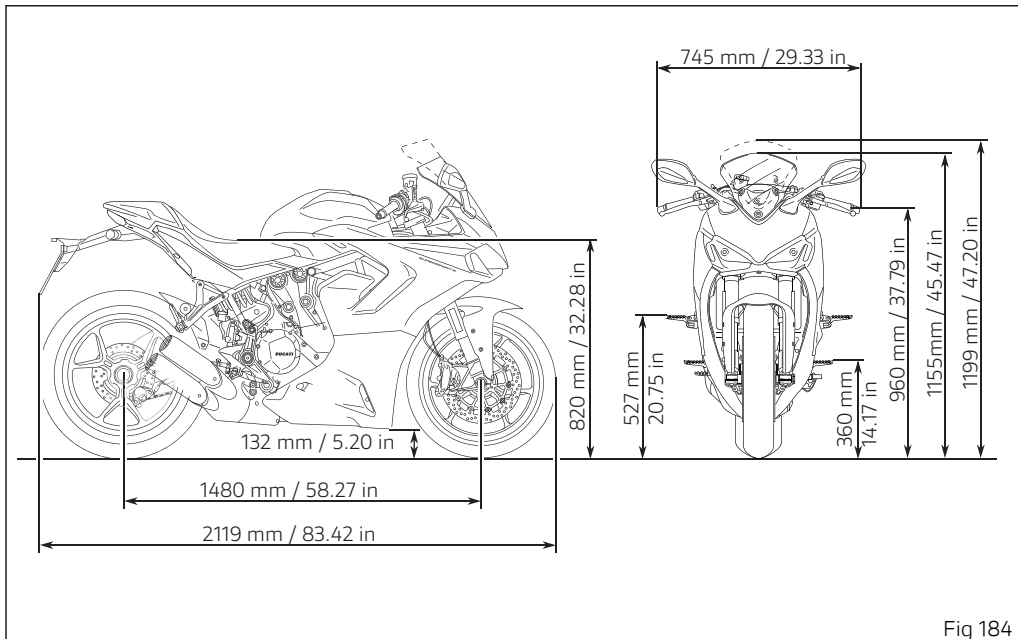

Fig 184

Fuel, lubricants and other fluids

TOP-UPS	TYPE	
Fuel tank, including a reserve of 4 litres (0.88 UK gal)	Ducati recommends SHELL V-Power unleaded premium fuel with a minimum of octane rating of RON 95	16 litres (3.52 UK gal)
Oil sump and filter	Ducati prescribes the only use of SAE 15W-50/JASO MA2 oil and recommends the use of Shell Advance 4T Ultra 15W-50 oil (JASO: MA2 and API: SN) SHELL Advance DUCATI 15W-50 Fully Synthetic Oil (UK VERSION)	3.2 litres (0.70 UK gal)
Front/rear brake circuit	DOT 4	-
Protectant for electric contacts	Protective spray for electric systems	-
Marzocchi front fork (Supersport)	SHELL Donax TA	435 cc (26.5 cu. in) (right leg) 435 cc (26.5 cu. in) (left leg) 130±2mm (5.12±0.08 in) measured without preload tube and with leg fully home, per leg

TOP-UPS	TYPE	
Öhlins front fork (Supersport S)	SHELL Donax TA	587.5 cc (35.85 cu. in) (right leg)
		587.5 cc (35.85 cu. in) (left leg) 150±2mm (5.90±0.08 in) measured without preload tube and with leg fully home, per leg
Cooling circuit	ENI Agip Permanent Spezial antifreeze (do not dilute, use pure)	2.3 litres (0.51 UK gal)



Important

Do not use any additives in fuel or lubricants. Using them could result in severe damage of the engine and motorcycle components.



Attention

The motorcycle is only compatible with fuel having a maximum content of ethanol of 10% (E10). Using fuel with ethanol content over 10% is forbidden. Using it could result in severe damage of the engine and motorcycle components. Using fuel with ethanol content over 10% will make the warranty null and void.

 **Important**

These references indicate the fuel recommended for this vehicle as specified by the European regulation EN228.



Engine

Testastretta 11°, twin cylinder, "L" type,
Desmodromic timing system, 4 valves per cylinder,
liquid cooling.

Bore: 94 mm (3.7 in).

Stroke: 67.5 mm (2.7 in).

Total displacement: 937 cu. cm (57.18 cu in).

Compression ratio: (12.6±0.5):1.

Maximum power at crankshaft (EU) Regulation no.
134/2014, Annex X, kW/HP:

81 kW/110 HP at 9,000 rpm.

Maximum torque at crankshaft (EU) Regulation no.
134/2014 Annex X:

93 Nm/9.5 kgm at 6,500 rpm

Max. rotation speed: 10,200 rpm.



Important

Do not exceed the specified rpm limits in any
running conditions.



Note

The indicated power/torque values have been
measured with a static test bench according to type-
approval standards and match with the data
detected during type-approval process; they are
indicated in the vehicle registration document.

Timing system

DESMODROMIC system with four valves per cylinder controlled by eight rocker arms and two overhead camshafts. This system is driven by the crankshaft through spur gears, belt rollers and toothed belts.

Desmodromic timing system

- 1) Opening (or upper) rocker arm;
- 2) Upper rocker arm shim;
- 3) Closing (or lower) rocker arm shim;
- 4) Return spring for lower rocker arm;
- 5) Closing (or lower) rocker arm;
- 6) Camshaft;
- 7) Valve.

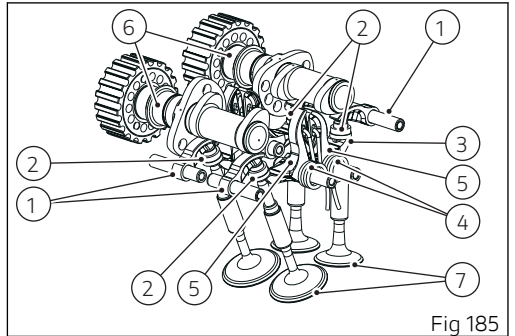

Fig 185

Performance data

Maximum speed in any gear should be reached only after a correct running-in period with the motorcycle properly serviced at the recommended intervals.

Important

Failure to follow these instructions releases Ducati Motor Holding S.p.A. from any liability whatsoever for any engine damage or shorter engine life.

Spark plugs

Make: NGK.

Type: MAR9A-J.

Fuel system

Electronic injection with throttle bodies with full Ride-by-Wire system.

Diameter of throttle body: 53 mm (2.1 in).

Injectors per cylinder: 1.

Fuel supply: 95-98 RON.

Attention

The motorcycle is only compatible with fuel having a maximum content of ethanol of 10% (E10). Using fuel with ethanol content over 10% is forbidden. Using it could result in severe damage to the engine and motorcycle components. Using fuel with ethanol content over 10% will make the warranty null and void.

Brakes

Separate-action anti-lock braking system operated by hall-type sensors mounted to each wheel with phonic wheel detection: ABS can be disabled.

FRONT

Brake discs

Semi-floating twin-disc.

Disc diameter: 320 mm (12.6 in).

Braking material: stainless steel.

Carrier material: aluminium, black colour.

Disc thickness: 4.5 mm (0.18 in).

Disc thickness (maximum wear): 4.0 mm (0.16 in).

Braking surface: 278 sq. cm (0.43 in²).

Brake control

Hydraulically operated by a lever on RH handlebar.

Brake master cylinder

Radial brake master cylinder with ABS Bosch Cornering, self-draining.

Brake master cylinder type: PR 18/21

Brake callipers

Brake calliper make: BREMBO, radially-mounted monobloc callipers.

Front brake calliper type: M4.32.

Number of pistons: 4.

Piston diameter: 32 mm (1.26 in).

Friction material: TT 2182.

REAR

Brake discs

With fixed drilled steel disc.

Disc diameter: 245 mm (9.6 in).

Disc thickness: 5 mm (0.2 in).

Disc thickness (maximum wear): 4.5 mm (0.18 in).

Braking surface: 209 sq. cm (0.32 in²).

Brake control

Hydraulically operated by a pedal on RH side.

Brake master cylinder

Cylinder Ø: 18 mm (0.71 in).

Brake callipers

Brake calliper make: BREMBO, floating 2-piston calliper with ABS Bosch Cornering.

Rear brake calliper type: P34.

Piston diameter: 34 mm (1.34 in).

Friction material: TOSHIBA TT 2172 HH.



Attention

The brake fluid used in the brake system is corrosive.

In the event of accidental contact with eyes or skin, wash the affected area with abundant running water.

Transmission

Hydraulically-controlled slipper wet multiplate clutch.

Self-draining master cylinder.

Drive is transmitted from engine to gearbox primary shaft via spur gears, 1.84:1 ratio.

Front chain sprocket/clutch gearwheel ratio: 33/61.

6-speed gearbox with Ducati Quick Shift (DQS) up/down EVO2

Gearbox output sprocket/rear chain sprocket ratio: 15/43.

Total gear ratios:

1st 37/15

2nd gear 30/17

3rd gear 28/20

4th 26/22

5th 24/23

6th gear 23/24

Drive chain from gearbox to rear wheel.

Make: Regina 520 ZRDK

Links: 105+1

Important

The above gear ratios are the homologated ones and under no circumstances must they be modified.

However, if you wish to tune up your motorcycle for competitions or special tracks, Ducati Motor Holding S.p.A. will be pleased to provide information about the special ratios available. Contact a Ducati Dealer or Authorised Service Centre.

Attention

If the rear sprocket needs replacing, contact a Ducati Dealer or authorised Service Centre. If improperly replaced, this component could seriously endanger your safety, as well as the passenger one, and cause irreparable damage to your motorcycle.

Frame

Steel tubular trellis fixed to the heads.

Rear steel tubular trellis sub-frame.

Steering head angle: 24°.

Trail: 91 mm (3.6 in)

Steering angle: 30° LH side / 30° RH side.

Wheels

Front

Light alloy rim with 3 Y-shaped spokes.

Size: 3.50" x 17".

Rear

Light alloy rim with 3 Y-shaped spokes.

Size: 5.50" x 17".

Tyres

Tyre type

Front (Tubeless)

Pirelli Diablo Rosso III.

Size: 120/70 ZR17 M/C (58W)TL

Rear (Tubeless)

Pirelli Diablo Rosso III.

Size: 180/55 ZR17 M/C (73W)TL

Tyre pressure

Front wheel

Rider only: 2.5 bar (36.26 PSI)
Rider, passenger, bags: 2.5 bar (36.26 PSI)

Rear wheel

Rider only: 2.5 bar (36.26 PSI)
Rider, passenger, bags: 2.8 bar (40.61 PSI)

Suspension

Front fork

Supersport

Marzocchi upside-down fork adjustable in rebound, compression, and spring preload.
Stanchion diameter: 43 mm (1.7 in).
Wheel travel: 130 mm (5.1 in).

Supersport S

Öhlins upside-down fork adjustable in rebound, compression, and spring preload with TIN coating of the legs.
Stanchion diameter: 48 mm (1.9 in).
Wheel travel: 130 mm (5.1 in).

Rear shock absorber

Supersport

Progressive with SACHS adjustable monoshock.
Suspension travel: 62.5 mm (2.46 in).
Rear wheel travel: 144 mm (5.7 in).

Supersport S

Progressive with Öhlins completely adjustable monoshock.
Suspension travel: 62 mm (2.44 in).
Rear wheel travel: 144 mm (5.7 in).

REAR SWINGING ARM

Aluminium single-sided swinging arm.

Exhaust system

Stainless steel silencer with separate aluminium tailpipe covers.
2 lambda sensors and 2 catalytic converters.

Available colours

Supersport

Ducati anniversary red

- 1) Primer, Antiflex White
SUPPLIER Lechler, CODE L00440652;
- 2) Base coat, Ducati Red
SUPPLIER PPG, CODE 473.101;
- 3) Clear coat, SUPPLIER PPG, CODE 228.880;
- 4) Red frame;
- 5) Rims, Black.

Supersport S

Ducati anniversary red

- 1) Primer, Antiflex White
SUPPLIER Lechler, CODE L00440652;
- 2) Base coat, Ducati Red
SUPPLIER PPG, CODE 473.101;
- 3) Clear coat, SUPPLIER PPG, CODE 228.880;
- 4) Red frame;
- 5) Rims, Black.

Artick White Silk

- 1) Primer
SUPPLIER Lechler, CODE L2920057;
- 2) Base coat
SUPPLIER Lechler, CODE L2909004;
- 3) Clear coat
SUPPLIER Lechler, CODE 96598;
- 4) Red frame
SUPPLIER Akzo Nobel, CODE QG000K;
- 5) Rims, glossy black + TAG powder primer
SUPPLIER Akzo Nobel, CODE EP050V;
- 6) Varnish
SUPPLIER Akzo Nobel, CODE 43NL0004;

Electric system

Basic electric items are:

Dashboard:

COBO instrument panel with TFT colour display.

Front optical unit

low beam: 2 LEDs;

high beam: 2 LEDs;

parking light / DRL: 6 LEDs;

Front turn indicators: 15 LEDs;

Rear optical unit

rear parking light: 8 LEDs;

rear brake (stop) light: 12 LEDs;

number plate light: 3 LEDs;

Rear LED turn indicators;

Rear turn indicators (USA): 1 bulb.

Electric controls on handlebars.

Horn.

Stop/light switches.

Hermetic type battery (YUASA YT 7B-BS DRY): 12V - 6.5 Ah.

Generator: Denso 14V - 490W.

Electronic rectifier, protected by a 30A fuse located on the solenoid starter (C), under the battery.

Starter motor: 12V - 0.7kW.



Note

For bulb replacement instructions, please see the paragraph "Replacing the high and low beam bulbs".

Fuses

There are twelve fuses that protect the electric components, located inside the front fuse boxes, and one on the electric solenoid starter. There is a spare fuse in every box.

Refer to the table below to identify the circuits protected by the various fuses and their ratings.

The rear (A) and front (B) fuse boxes are located on the front right side, inside the fairing.

To expose the fuses, lift the box protective cover.

Mounting position and ampere capacity are marked on box cover.

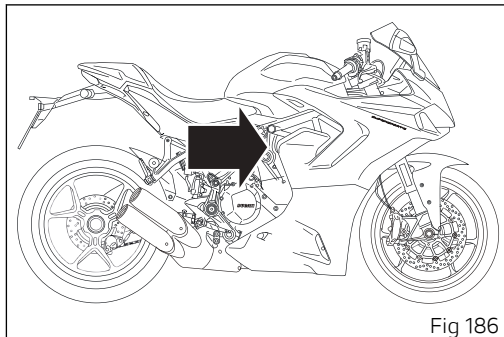

Fig 186

Fuse box (A) key		
Pos	El. item	Rat.
1	Lights	—
2	Instrument panel	15 A
3	Key 1	10 A
4	RHS	7.5 A
5	El. loads relay	20 A
6	Fuel pump relay	10 A
7	BBS	10 A
8	Spare	15 A
9	Spare	20 A
10	Spare	10 A

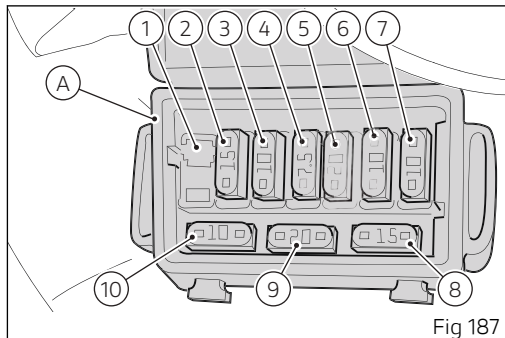

Fig 187

Fuse box (B) key		
Pos	El. item	Rat.
1	Optional Key	7.5 A
2	Alarm	5 A
3	Stop	5 A
4	Diagnostics	5 A
5	Spare	30 A
6	Spare	25 A
7	Spare	7.5 A

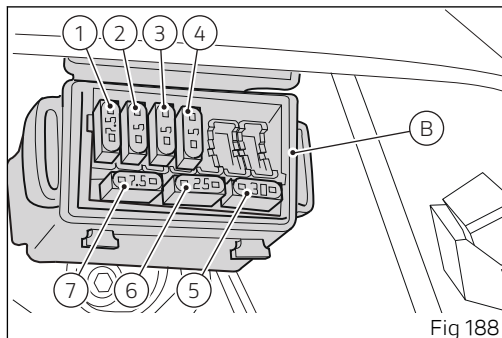

Fig 188

To access the 30A main fuse, remove the left half fairing by contacting a Dealer or Authorised Service Centre.

The main fuse (C) is located near the battery on solenoid starter (D): fuse (L) is a spare fuse. Remove the fuse cap (E) to reach it.

A blown fuse can be identified by breakage of the inner filament (F).

Near the solenoid starter there are two ABS fuses: a 25 A (G) fuse and a 10 A (H) one.

Important

Switch the ignition key to OFF before replacing the fuse to avoid possible short-circuits.

Attention

Never use a fuse with a rating other than specified. Failure to observe this rule may damage the electric system or even cause fire.

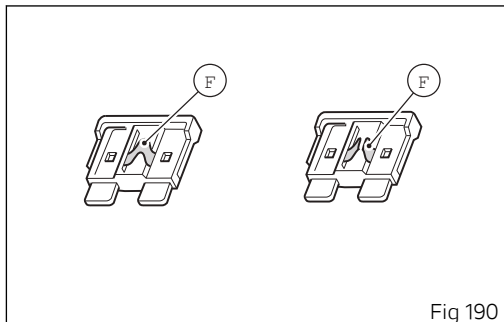
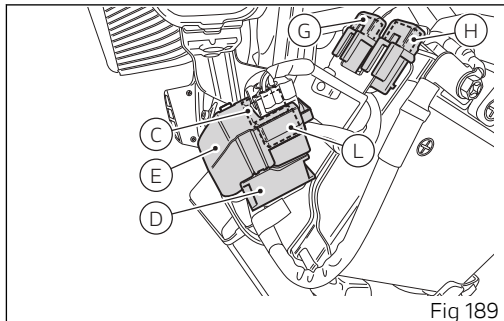

Open source software

Information about open source software

Some vehicle components use open source software. The source code used and information on open source is available online at the following link:
<https://www.ducati.com/ww/en/home/open-source-software>

Declarations of conformity

Declarations of conformity

EU Directive 2014/53/EU



Addresses of radio component manufacturers

All radio components must carry the manufacturer's address according to the provisions of directive 2014/53/EU. For components that, due to their size or nature, cannot be furnished with a sticker, the respective manufacturers' addresses as required by law are listed in the table 2.

Note

Only skilled person can access and install the device.

Table 1

Radio equipment installed in the vehicle	Frequency band	Max. transmission power
--	----------------	-------------------------

Instrument panel	134.7 KHz 119 KHz ÷ 135 KHz	< 66 dB μ A/m (10 m)
Ducati Multimedia System (Bluetooth)	2402 ÷ 2480 MHz	4.4mW
Antitheft	433.92MHz (\pm 75KHz)	<0.6mA

Table 2

Radio equipment installed in the vehicle	Manufacturers' addresses
Instrument panel	COBO S.p.a. Via Tito Speri, 10 25024 Leno (BS), Italy
Ducati Multimedia System (Bluetooth)	COBO S.p.a. Via Tito Speri, 10 25024 Leno (BS), Italy
Antitheft	PATROLLINE Via Cesare Cantù, 15/C 22031 Albavilla (CO), Italy

Simplified EU declaration of conformity

[Austria]

Ihr Fahrzeug ist mit einer Reihe von Funkgeräten ausgestattet. Die Hersteller dieser Funkgeräte erklären, dass diese, wo gesetzlich vorgeschrieben, mit der Richtlinie 2014/53/EU übereinstimmen. Der vollständige Text der EU-Konformitätserklärung ist unter folgender Adresse verfügbar: certifications.ducati.com

[Belgium]

Votre véhicule est équipé d'une série d'appareillages radio. Les constructeurs de ces appareillages radio déclarent que ces derniers sont conformes à la directive 2014/53/UE lorsque la loi le requiert. Le texte complet de la déclaration de conformité UE est disponible à l'adresse suivante : certifications.ducati.com

[Bulgaria]

Твоят мотоциклет е оборудван с различна по вид радиоапаратура. Производителите на тази радиоапаратура декларират, че тя съответства на Директива 2014/53/ЕС, съгласно изискванията по закон. Пълният текст на декларацията за съответствие ЕС, ще намерите на следния адрес: certifications.ducati.com

[Cyprus]

Το όχημά σας εξοπλίζεται με μια σειρά από ραδιοσυσκευές. Οι κατασκευαστές των συσκευών αυτών δηλώνουν ότι οι συσκευές συμμορφώνονται με την οδηγία 2014/53/ΕΕ, όπου απαιτείται από το νόμο. Το πλήρες κείμενο της δήλωσης συμμόρφωσης ΕΕ είναι διαθέσιμο στη διεύθυνση: certifications.ducati.com

[Czech Republic]

Vaše vozidlo je vybaveno řadou rádiových zařízení. Výrobci těchto radio zařízení, prohlašují, že zařízení jsou v souladu se směrnicí 2014/53/EU, pokud to vyžaduje zákon. Úplné znění prohlášení o shodě EU je k dispozici na internetových stránkách: certifications.ducati.com

[Germany]

Ihr Fahrzeug ist mit einer Reihe von Funkgeräten ausgestattet. Die Hersteller dieser Funkgeräte erklären, dass diese, wo gesetzlich vorgeschrieben, mit der Richtlinie 2014/53/EU übereinstimmen. Der vollständige Text der EU-Konformitätserklärung ist unter folgender Adresse verfügbar: certifications.ducati.com

[Denmark]

Dit køretøj er udstyret med et udvalg af radioudstyr. Producenterne af dette radioudstyr erklærer, at dette udstyr overholder direktiv 2014/53/EU, hvis det kræves i henhold til loven. Den komplette tekst af EU-overensstemmelseserklæringen findes på følgende webadresse: certifications.ducati.com

[Estonia]

Teie sõiduk on varustatud raadioseadmete seeriaga. Selle raadioseadme tootjad kinnitavad, et see seade vastab direktiivile 2014/53/EÜ, kui seadus seda nõuab. EÜ vastavusdeklaratsiooni terviktekst on saadaval järgmisel veebisaidil: certifications.ducati.com

[Spain]

Su vehículo está equipado con una serie de equipos de radio. Los fabricantes de dichos equipos de radio declaran su conformidad con la directiva 2014/53/UE, como requiere la ley. El texto completo de la declaración de conformidad UE está disponible en el siguiente sitio: certifications.ducati.com

[Finland]

Ajoneuvossasi on radiolaitteita. Näiden radiolaitteiden valmistajat vakuuttavat, että laitteet vastaavat direktiiviä 2014/53/EU lain edellyttämällä tavalla. EU-vaatimustenmukaisuusvakuutuksen täydellinen teksti on saatavilla seuraavasta osoitteesta: certifications.ducati.com

[France]

Votre véhicule est équipé d'une série d'appareillages radio. Les constructeurs de ces appareillages radio déclarent que ces derniers sont conformes à la directive 2014/53/UE lorsque la loi le requiert. Le texte complet de la déclaration de conformité UE est disponible à l'adresse suivante : certifications.ducati.com

[United Kingdom]

Your vehicle is equipped with a range of radio equipment. The manufacturers of this radio equipment declare that these equipment complies with Directive 2014/53/EU where required by law. The complete text of the EU declaration of conformity is available at the following web address: certifications.ducati.com

[Greece]

Το όχημά σας εξοπλίζεται με μια σειρά από ραδιοσυσκευές. Οι κατασκευαστές των συσκευών αυτών δηλώνουν ότι οι συσκευές συμμορφώνονται με την οδηγία 2014/53/ΕΕ, όπου απαιτείται από το νόμο. Το πλήρες κείμενο της δήλωσης συμμόρφωσης ΕΕ είναι διαθέσιμο στη διεύθυνση: certifications.ducati.com

[Croatia]

Vaše vozilo je opremljeno nizom radio uređaja. Proizvođači ovih radio uređaja tvrde da su uređaji u skladu s Direktivom 2014/53/UE ako je propisano zakonom. Cjelokupan tekst deklaracije o sukladnosti dostupan je na: certifications.ducati.com

[Hungary]

Járműved egy sor rádió készülékkel van felszerelve. Ezeknek a rádióberendezéseknek a gyártói kijelentik, hogy a készülékek megfelelnek a 2014/53/EU irányelvnek, ahol ezt a törvény megköveteli. Az EU megfelelőségi nyilatkozat teljes szövege az alábbi címen érhető el: certifications.ducati.com

[Ireland]

Your vehicle is equipped with a range of radio equipment. The manufacturers of this radio equipment declare that these equipment complies with Directive 2014/53/EU where required by law. The complete text of the EU declaration of conformity is available at the following web address: certifications.ducati.com

[Italy]

Il tuo veicolo è dotato di una serie di apparecchiature radio. I costruttori di queste apparecchiature radio dichiarano che esse sono conformi alla direttiva 2014/53/UE laddove richiesto per legge. Il testo completo della dichiarazione di conformità UE è disponibile al seguente indirizzo: certifications.ducati.com

[Lithuania]

Jūsų transporto priemonėje įdiegta daug įvairios radijo įrangos. Šios radijo įrangos gamintojai patvirtina, kad ji atitinka 2014/53/ES direktyvos reikalavimus, kaip tai numato galiojantys įstatymai. Visas ES atitikties deklaracijos tekstas pateikiamas svetainėje adresu certifications.ducati.com

[Luxembourg]

Votre véhicule est équipé d'une série d'appareillages radio. Les constructeurs de ces appareillages radio déclarent que ces derniers sont conformes à la directive 2014/53/UE lorsque la loi le requiert. Le texte complet de la déclaration de conformité UE est disponible à l'adresse suivante : certifications.ducati.com

[Latvia]

Jūsu transportlīdzeklis ir aprīkots ar dažādām radioierīcēm. Šo radioierīču ražotājs apliecina, ka ierīces atbilst Direktīvas 2014/53/ES prasībām, ja to paredz attiecīgie tiesību akti. Pilnīgo ES atbilstības deklarāciju skatiet šajā tīmekļa vietnē: certifications.ducati.com

[Malta]

Il-vettura tiegħek hija mgħammra b'firxa ta' tagħmir tar-radju. Il-manufatturi ta' dan it-tagħmir tar-radju jiddikjaraw li dan it-tagħmir jikkonforma mad-Direttiva 2014/53/UE fejn meħtieġ mil-liġi. It-test kollu tad-dikjarazzjoni ta' konformità tal-UE huwa disponibbli fuq l-indirizz tal-web: certifications.ducati.com

[Netherlands]

Uw voertuig is voorzien van diverse draadloze apparatuur. De fabrikanten van deze draadloze apparatuur verklaren dat deze, daar waar dit door de wet voorschreven wordt, overeenstemmen met de richtlijn 2014/53/EU. De volledige tekst van de EU-verklaring van overeenstemming is beschikbaar op het volgende webadres: certifications.ducati.com

[Poland]

Państwa pojazd został wyposażony w szereg urządzeń radiowych. Producenci tych urządzeń radiowych oświadczają, że są one zgodne z dyrektywą 2014/53/UE, tam, gdzie wymaga tego prawo. Pełny tekst deklaracji zgodności UE jest dostępny pod następującym adresem internetowym: certifications.ducati.com

[Portugal]

O seu veículo é dotado de uma série de equipamentos de rádio. Os construtores desses equipamentos de rádio declaram que os mesmos estão em conformidade com a diretiva 2014/53/UE sempre que a lei o

determinar. O texto completo da declaração de conformidade UE está disponível no seguinte endereço: certifications.ducati.com

[Romania]

Vehiculul dvs. este dotat cu o serie de aparate radio. Producătorii acestor aparate radio declară că acestea sunt conforme cu directiva 2014/53/UE, dacă legea impune acest lucru. Textul complet al declarației de conformitate UE este disponibil la următoarea adresă: certifications.ducati.com

[Sweden]

Ditt fordon är utrustat med radioutrustning. Radioutrustningens tillverkare förklarar att denna utrustning uppfyller direktiv 2014/53/EU där så lagen kräver det. Fullständig text om EU-försäkran om överensstämmelse finns på följande adress: certifications.ducati.com

[Slovenia]

Vaše vozilo ima tudi vrsto radijske opreme. Proizvajalci eteh radijskih naprav izjavljajo, da so ti v skladu z uredbo 2014/53/UE, kjer zakon to predvideva. Celotno besedilo izjave o skladnosti EU je na voljo na spodnjem naslovu: certifications.ducati.com

[Slovakia]

Vaše vozidlo je vybavené rádiovými zariadeniami. Výrobcovia týchto rádiových zariadení prehlasujú, že tieto zariadenia sú v zhode so smernicou 2014/53/EÚ v rozsahu predpísanom zákonom. Úplný text ES prehlásenia o zhode je k dispozícii na nasledujúcej adrese: certifications.ducati.com

United States (USA)

"This device complies with Part 15 of the FCC Rules.

Operation is subject to the following two conditions: (1) this device may not cause harmful interference, and (2) this device must accept any interference received, including interference that may cause undesired operation."

"Changes or modifications not expressly approved by the party responsible for compliance could void the user's authority to operate the equipment." "NOTE: This equipment has been tested and found to comply with the limits for a Class B digital device, pursuant to Part 15 of the FCC Rules. These limits are designed to provide reasonable protection against harmful interference in a residential installation. This equipment generates, uses and can radiate radio frequency energy and, if not installed and used in accordance with the instructions, may cause harmful interference to radio communications. However, there is no guarantee that interference will not occur in a particular installation. If this equipment does cause harmful interference to radio or television reception, which can be determined by turning the equipment off and on, the user is encouraged to try to correct the interference by one or more of the following measures:

- Reorient or relocate the receiving antenna.
- Increase the separation between the equipment and receiver.
- Connect the equipment into an outlet on a circuit different from that to which the receiver is connected.
- Consult the dealer or an experienced radio/TV technician for help."

- RF exposure Information according 2.1091/2.1093 / OET bulletin 65:

Radiofrequency radiation exposure Information: This equipment complies with FCC radiation exposure limits set forth for an uncontrolled environment. This equipment should be installed and operated with minimum distance of 20 cm between the radiator and your body. This transmitter must not be co-located or operating in conjunction with any other antenna or transmitter.

The manufacturers of these radio equipment declare that devices comply with the FCC

DASHBOARD	FCC ID: 2AVOV-04610311
DUCATI MULTIMEDIA SYSTEM (Bluetooth)	FCC ID: Z64-2564N

Canada

This device contains licence-exempt transmitter(s)/ receiver(s) that comply with Innovation, Science and Economic Development Canada's licence-exempt RSS(s). Operation is subject to the following two conditions:

- (1) This device may not cause interference.
- (2) This device must accept any interference, including interference that may cause undesired operation of the device.

L'émetteur/récepteur exempt de licence contenu dans le présent appareil est conforme aux CNR d'Innovation, Sciences et Développement économique Canada applicables aux appareils radio exempts de licence. L'exploitation est autorisée aux deux conditions suivantes:

- (1) L'appareil ne doit pas produire de brouillage;
- (2) L'appareil doit accepter tout brouillage radioélectrique subi, même si le brouillage est susceptible d'en compromettre le fonctionnement.

RF Exposure Information:

This equipment complies with Canada radiation exposure limits set forth for an uncontrolled environment. This equipment should be installed and operated with minimum distance of 20 cm between the radiator and your body.

Déclaration d'exposition aux radiations: Cet équipement est conforme aux limites d'exposition aux rayonnements IC établies pour un environnement non contrôlé. Cet équipement doit être installé et utilisé avec un minimum de 20 cm de distance entre la source de rayonnement et votre corps.

DASHBOARD	IC: 25864-04610311
DUCATI MULTIMEDIA SYSTEM (Bluetooth)	IC: 4511-2564N

DUCATI MULTIMEDIA SYSTEM (Bluetooth)

Japan

当該機器には電波法に基づく、技術基準適合証明等を受けた特定無線設備を装着している。

This equipment contains specified radio equipment that has been certified to the technical regulation conformity certification under the Radio Law.

本無線機器の改造を禁ずる（これに反した場合は当該認証登録番号は無効となる）

This radio device should not be modified (otherwise the granted designation number will become invalid)

South Korea



91375681EN





Ducati Motor Holding spa
ducati.com

Via Cavalieri Ducati, 3
40132 Bologna, Italy
Ph. +39 051 6413111
Fax +39 051 406580

A Sole Shareholder Company
A Company subject to the Management
and Coordination activities of AUDI AG