

CLYMER
PUBLICATIONS

GARELLI MOPED

OWNER SERVICE / REPAIR

1976-1978



GARELLI MOPED

OWNER SERVICE / REPAIR

1976-1978

By

ED SCOTT

ERIC JORGENSEN

Editor

JEFF ROBINSON

Publisher

CLYMER PUBLICATIONS

*World's largest publisher of books devoted exclusively to
automobiles, motorcycles, and boats.*

222 NORTH VIRGIL AVENUE, LOS ANGELES, CALIFORNIA 90004

CONTENTS

CHAPTER ONE

GENERAL INFORMATION 1

- | | |
|---------------------|---------------------|
| Basic components | Safety first |
| Manual organization | Parts replacement |
| Service hints | Expendable supplies |

CHAPTER TWO

BASIC HAND TOOLS 7

- | | |
|--------------------------------|-----------------|
| Fasteners | Torque wrench |
| Screwdrivers | Impact driver |
| Pliers | Ignition gauge |
| Box and open-end wrenches | Tire lever |
| Adjustable (crescent) wrenches | Spoke wrench |
| Socket wrenches | Cable cutter |
| Cone wrenches | Mechanic's tips |

CHAPTER THREE

TUNE-UP, LUBRICATION, AND MAINTENANCE 14

- | | |
|-------------------|----------------------|
| Engine tune-up | Periodic lubrication |
| Lubricants | Periodic maintenance |
| Cleaning solvents | |

CHAPTER FOUR

TROUBLESHOOTING 27

- | | |
|---------------------------|------------|
| Operating requirements | Brakes |
| Emergency troubleshooting | Electrical |
| Engine | Suspension |
| Clutch | |

CHAPTER FIVE

ENGINE 31

- | | |
|----------------------|-------------------------|
| Engine principles | Cylinder |
| Lubrication | Piston and wrist pin |
| Cooling | Piston ring replacement |
| Removal/installation | Crankcase |
| Cylinder head | Crankshaft |

CHAPTER ONE

GENERAL INFORMATION

Although mopeds have long been a favorite in Europe, it is only recently that they have become popular in the United States. Today they are more numerous and are ridden more often than ever before.

The majority of moped dealers also sell bicycles or motorcycles. The number of competent mechanics available cannot keep pace with the demand. Moped owners must often do their own maintenance and repair.

Moped maintenance and repair is not difficult if you know what tools to use and what to do. Anyone not afraid to get his or her hands dirty, of average intelligence, and with enough mechanical ability to change a light bulb can perform most of the procedures in this book.

In some cases, a repair job may require tools or skills not reasonably expected of the home mechanic. These instances are noted in each chapter and it is recommended that you take the job to your dealer, a competent mechanic or machine shop.

BASIC COMPONENTS

Basically the moped is an engine powered bicycle. It has two pedals and can be ridden as an ordinary bicycle without running the engine. **Figure 1** shows the major components of the Garelli.

Frame

The frame is a heavy duty, step-through bicycle frame with provisions for an engine.

Engine

The engine is a very simple one-cylinder, 2-stroke engine cooled by air. It produces approximately two horsepower. This is the same type of engine used on outboard motors, lawn mowers, and many motorcycles. It is very reliable and it is easy to maintain.

Clutch/Transmission

The clutch/transmission is automatic, that is, there are no gears to shift and no clutch pedal or lever to worry about. The engine power is transferred to the rear wheel by a drive chain just like on a bicycle or motorcycle.

Suspension

Spring type front forks and rear shock absorbers smooth out rough roads. These are similar to those used on motorcycles but are simpler and require very little maintenance.

Brakes

The brakes are operated by levers on the handlebar, similar to those used on bicycles and

①

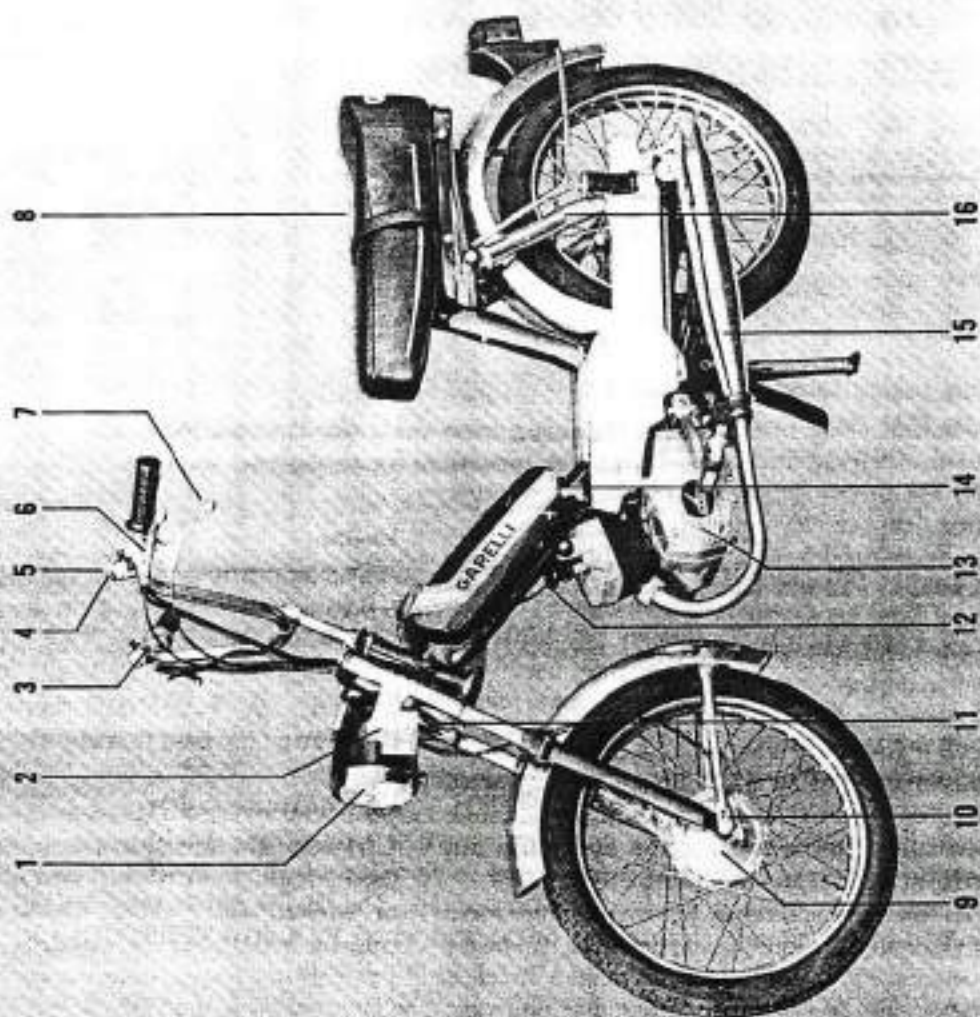

**GARELLI
COMPONENTS**

1. Headlight
2. Side reflex reflector (amber)
3. Engine cutoff switch
4. Horn button
5. Light switch
6. Brake lever — rear
7. Clutch start lever
8. Seat
9. Front brake/hub
10. Speedometer sending unit
11. Horn
12. Spark plug
13. Clutch/transmission
14. Fuel shutoff valve
15. Muffler
16. Rear shock absorber
17. Combination taillight/bracketlight
18. Fuel tank
19. Fuel fill cap
20. Throttle control
21. Brake lever — front
22. Speedometer
23. Headlight adjustment bolt
24. Front fork assembly
25. Side reflex reflector (red)
26. Rear brake/hub
27. Drive chain
28. Engine fairing
29. Centerstand
30. Pedal
31. Magneto
32. Front fork assembly

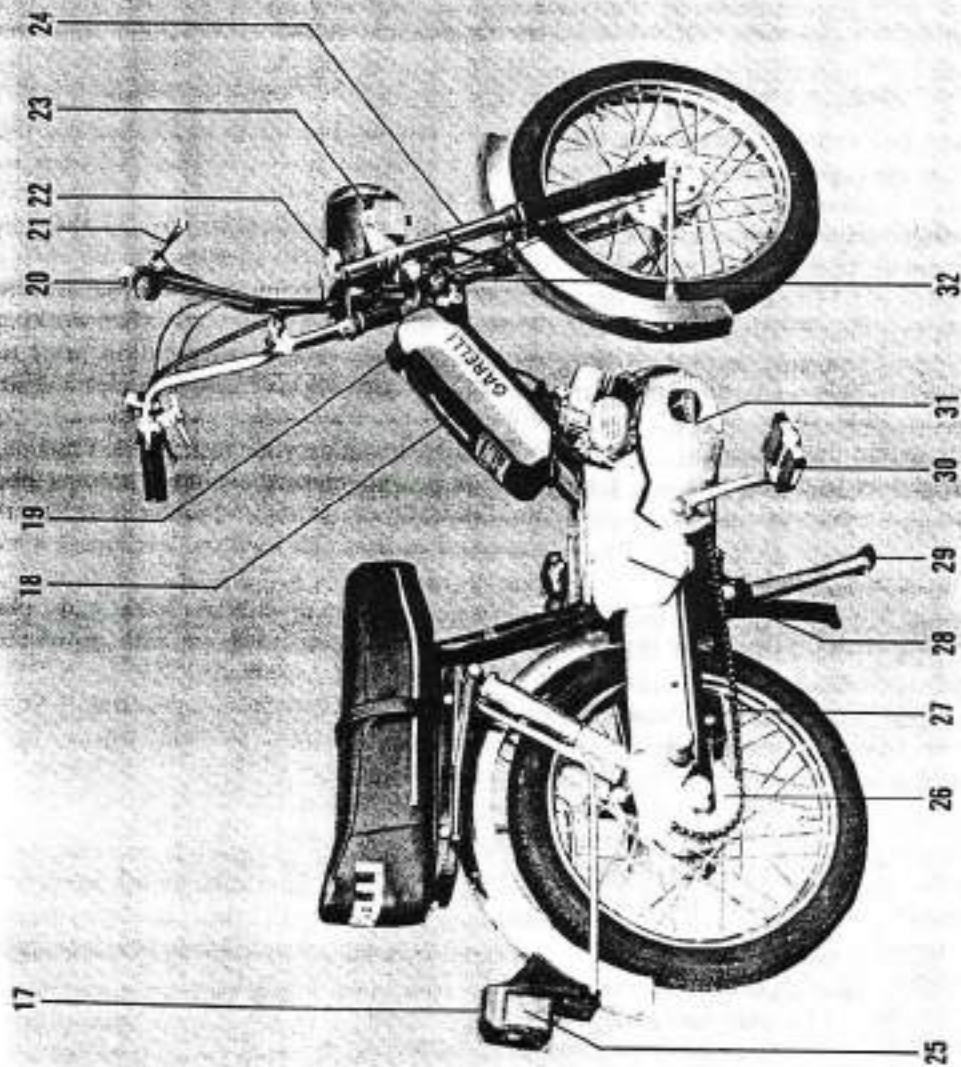

motorcycles. The left hand operates the rear brakes and the right hand, the front brake.

Wheels and Tires

Wheels and tires are basically the same as those used on bicycles except that they are a little heavier in order to accommodate the additional weight of the moped.

Lighting and Instruments

There is no battery to be concerned with on a moped. The electricity for lights and spark plug is provided by a small generator called a magneto. It is similar to the generator on an automobile. The only instrument is the speedometer and it is illuminated for use at night.

MANUAL ORGANIZATION

This manual provides service information and instructions for your moped. All dimensions and capacities are expressed in English units familiar to U.S. mechanics as well as in metric units.

Some of the procedures in this manual specify special tools. In all cases, the tool is illustrated either in actual use or alone. A well-equipped mechanic may find that he can substitute similar tools already on hand or can fabricate his own.

The terms **NOTE**, **CAUTION** and **WARNING** have specific meanings in this manual. A **NOTE** provides additional information to make a step or procedure easier or clearer. Disregarding a **NOTE** could cause inconvenience, but would not cause damage or personal injury.

A **CAUTION** emphasizes areas where equipment damage could result. Disregarding a **CAUTION** could cause permanent equipment damage; however, personal injury is unlikely.

A **WARNING** emphasizes areas where personal injury or even death could result from negligence. Mechanical damage may also occur. **WARNINGS** are to be taken seriously. In some cases, serious injury or death has resulted from disregarding similar warnings.

Throughout this manual keep in mind two conventions. "Front" refers to the front of the moped. The front of any component such as

the engine is the end which faces toward the front of the moped. The left and right side refer to a person sitting on the seat facing forward. For example, the clutch/transmission is on the left side. These rules are simple, but even experienced mechanics occasionally become disoriented.

SERVICE HINTS

Most of the service procedures covered are straight-forward and can be performed by anyone reasonably handy with tools. It is suggested, however, that you consider your own capabilities carefully before attempting any operation involving major disassembly of the engine.

Some operations, for example, require the use of a hydraulic press. It would be wiser to have these performed by a shop equipped for such work, rather than try to do the job yourself with makeshift equipment.

There are many items available that can be used on your hands before and after working on your moped. A little preparation prior to getting "all greased up" will help cleaning up later.

Before starting on your task, work Vaseline, soap or a commercially available product like ProTek into your hands and under your fingernails and cuticles. This will make cleanup a lot easier.

For cleanup use a waterless hand soap, like Sta-Lube, and then finish up with powdered Boraxo and a fingernail brush.

Repairs go much easier and faster if your moped is clean before you begin work. There are special cleaners, like Gunk Cycle Degreaser, for washing the engine and related parts. Follow the manufacturer's instructions. Clean all oily or greasy parts with cleaning solvent as you remove them.

WARNING

Never use gasoline as a cleaning solvent. It presents an extreme fire hazard. Be sure to work in a well-ventilated area when using cleaning solvent. Keep a fire extinguisher, rated for gasoline fires, handy in any case.

Special tools are required for some repairs. These may be purchased at a dealer, rented from a tool rental dealer or fabricated by a mechanic or machinist, often at a considerable savings.

Much of the labor charge for repairs made by dealers is for the removal and disassembly of other parts to reach the defective unit. It is frequently possible to perform the preliminary operations yourself and then take the defective unit to the dealer for repair at a considerable savings.

Once you have decided to tackle the job yourself, read the entire section in this manual which pertains to it. Study the illustrations, photos and text until you have a good idea of what is involved in completing the job satisfactorily. If special tools are required, make arrangements to get them before you start. It is frustrating and time consuming to get partly into a job and then be unable to complete it.

During disassembly of parts, keep a few general cautions in mind. Force is rarely needed to get things apart. If parts have a tight fit, like a bearing in a case, there is usually a tool designed to separate them. Never use a screwdriver to pry apart parts with machined surfaces such as crankcase halves. You will mar the surfaces and end up with leaks.

Make drawings and diagrams whenever similar-appearing parts are found. You may think you can remember where everything came from — but mistakes could be costly. There is also the possibility you may be side tracked and not return to work for days or even weeks — in which interval carefully laid out parts may have become disturbed.

Tag all similar internal parts for location and mark all mating parts for position. Record numbers and thickness of any shims as they are removed. Small parts such as bolts can be identified by placing them in plastic sandwich bags. Seal and label with masking tape.

Wiring should be tagged with masking tape and marked as each wire is removed. Again, do not rely on memory alone. Protect finished surfaces from physical damage or corrosion. Keep gasoline off of painted surfaces.

Frozen or very tight bolts and screws can

often be loosened by soaking with penetrating oil, like Liquid Wrench or WD-40, then sharply striking the bolt head a few times with a hammer and punch (or screwdriver for screws). Avoid heat unless absolutely necessary, since it may melt, warp, or remove the temper from many parts.

Avoid flames or sparks when working near flammable liquids such as gasoline.

No parts, except those assembled with a press fit, require force during assembly. If a part is hard to remove or install, find out why before proceeding.

Cover all openings after removing parts to keep dirt, small tools, etc., from falling in.

When assembling two parts, start all fasteners, then tighten evenly.

Wiring connections and brake shoes should be kept clean and free of grease and oil.

When assembling parts, be sure all shims and washers are replaced exactly as they came out.

Whenever a rotating part butts against a stationary part, look for a shim or washer. Use new gaskets if there is any doubt about the condition of the old ones. Generally you should apply gasket cement to one mating surface only so the parts may be disassembled in the future. A thin coat of oil on gaskets helps them seal effectively.

Heavy grease can be used to hold small parts in place if they tend to fall out during assembly. However, keep grease and oil away from electrical components and brake parts.

Carbon can be removed from the head, the top of the piston and the exhaust port with a dull screwdriver. Do not scratch either surface. Then wipe off the surfaces with a clean cloth.

Carburetors are best cleaned by disassembling them and soaking the parts in a commercial carburetor cleaner. Never soak gaskets or plastic or rubber parts in these cleaners. Never use wire to clean out the jet and air passages; they are easily damaged. Use compressed air to blow out the carburetor only if the float has been removed first.

Take your time and do the job right. Do not forget that a newly rebuilt engine must be broken in the same as a new one.



SAFETY FIRST

Professional mechanics can work for years and never sustain a serious injury. If you observe a few rules of common sense and safety, you can enjoy many safe hours servicing your own moped. You could hurt yourself or damage the moped if you ignore these rules.

1. Never use gasoline as a cleaning solvent.
2. Never smoke or use a torch in the vicinity of flammable liquids, such as cleaning solvent in open containers.
3. Use the proper sized wrenches to avoid damage to nuts and injury to yourself.
4. When loosening a tight or stuck nut, be guided by what would happen if the wrench should slip. Protect yourself accordingly.
5. Keep your work area clean and uncluttered.
6. Wear safety goggles during all operations involving drilling, grinding or use of a cold chisel.
7. Never use worn tools.
8. Keep a fire extinguisher handy and be sure it is rated for gasoline and electrical fires.

PARTS REPLACEMENT

Manufacturers make frequent changes during the model year; some relatively major. When you order parts from the dealer or other parts distributor, always order by engine and frame number. Write the numbers down and carry them with you. Compare new parts to old before purchasing them. If they are not alike, have the parts manager explain the difference to you.

EXPENDABLE SUPPLIES

Certain expendable supplies are also required. These include grease, oil, gasket cement, wiping rags and cleaning solvent. Ask your dealer for the special locking compounds, silicone lubricants and commercial chain cleaners and lubrication products which make moped maintenance simpler and easier. Solvent is available at most service stations.

CHAPTER TWO

BASIC HAND TOOLS

A number of tools are required to maintain a moped in top condition. You may already have some around for other work such as home and car repairs. There are also tools made especially for moped repair; these you will have to purchase. In any case, a wide variety of quality tools will make moped repairs more effective and convenient.

Top quality tools are essential — and also more economical. Poor grade tools are made of inferior materials, and are thick, heavy, and clumsy. Their rough finish makes them difficult to clean and they usually don't stand up long.

Quality tools are made of alloy steel and are heat treated for greater strength. They are lighter and better balanced than inferior ones. Their surface is smooth, making them a pleasure to work with and easy to clean. The initial cost of top quality tools may be relatively high, but longer life and ease of use make them less expensive in the long run.

It is aggravating to search for a certain tool in the middle of a repair, only to find it covered with grime. Keep your tools in a tool box. Keep wrench sets, socket sets, etc., together. After using a tool, wipe off dirt and grease with a clean cloth and replace the tool in its correct place.

This chapter describes various hand tools required to perform virtually any repair job on a

moped. Each tool is described and recommendations as to proper size are made for those not familiar with hand tools. **Table 1** includes tools for emergency repairs on the road; **Table 2** includes tools which should be on hand at home for simple repairs or major overhaul.

FASTENERS

In order to better understand and select basic hand tools, a knowledge of various fasteners used on mopeds is important. This knowledge will also aid selecting replacements when fasteners are damaged or corroded beyond use.

Threads

Nuts, bolts, and screws are manufactured in a wide range of thread patterns. To join a nut and bolt, it is necessary that the bolt and the diameter of the hole in the nut be the same. It is

Table 1 EMERGENCY TOOL KIT

Tool	Size or Specification
Common screwdriver	Choose smallest tools possible to fit small carrying pouch.
Combination wrench 8 X 10mm	
Cone wrenches	
Tire levers	
Tire patch kit	

Table 2 HOME WORKSHOP TOOLS

Tool	Size or Specification
Screwdriver	
Slot	$\frac{1}{8}$ x 8 in. blade
Slot	$\frac{1}{8}$ x 12 in. blade
Phillips	Size 2 tip, 6 in. blade
Pliers	
Gas pliers	6 in. overall
Vise Grips	10 in. overall
Needle nose	6 in. overall
Channel lock	12 in. overall
Snapping	—
Wrenches	
Box-end set	8-19mm
Open-end set	8-19mm
Crescent (adjustable)	6 and 12 in. overall
Socket set	$\frac{1}{2}$ in. drive ratchet with 8-19mm sockets
Allen set	2-10mm
Cone wrenches	—
Spoke wrench	—
Other special tools	
Cable cutter	V-shaped cutting jaws
Impact driver	$\frac{1}{2}$ in. drive with assorted tips
Torque wrench	$\frac{1}{2}$ in. drive — 0-100 ft.-lb.
Tire levers	For moped or motorcycle tires

equally important that the threads on both be properly matched.

The best way to insure that threads on two fasteners are compatible is to turn the nut on the bolt with fingers only. If much force is required, check the thread condition on both fasteners. If thread condition is good, but the fasteners jam, the threads are not compatible. Take the fasteners to a hardware store or moped dealer for proper mates.

Most fasteners are cut so that a fastener must be turned clockwise to tighten it. These are called right-hand threads. Some moped components, such as pedals, have left-hand threads; they must be turned *counterclockwise* to tighten them.

When replacing threaded components, rely on you dealer's experience; take the old part in for replacement.

SCREWDRIVERS

The screwdriver is a very basic tool, but many people don't use it properly and do more damage than good. The slot on a screw has a

definite dimension and shape. A screwdriver must be selected to conform to that shape.

Two basic types of screwdrivers are required to repair the moped: a common screwdriver and a Phillips screwdriver. Both types are illustrated in **Figure 1**.

PLIERS

Pliers come in a wide range of types and sizes. Pliers are useful for cutting, bending, and crimping. They should never be used to cut hardened objects or to turn nuts or bolts. **Figure 2** shows several pliers useful for moped repairs.

BOX AND OPEN-END WRENCHES

Box wrenches and open-end wrenches are available in sets or separately in a variety of sizes. See **Figure 3 and 4**. The size stamped near the end refers to the distance between two parallel flats on a hex head bolt or nut.

A set covering 5 to 12, 17, and 22mm is adequate for service on the moped.

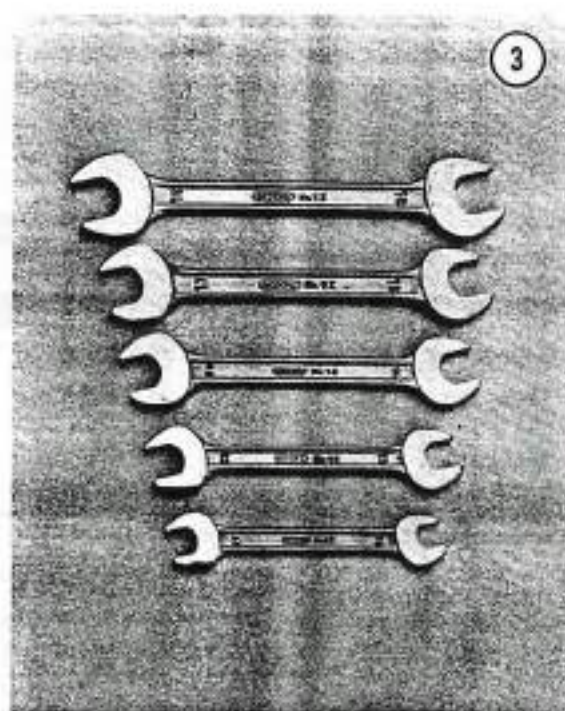
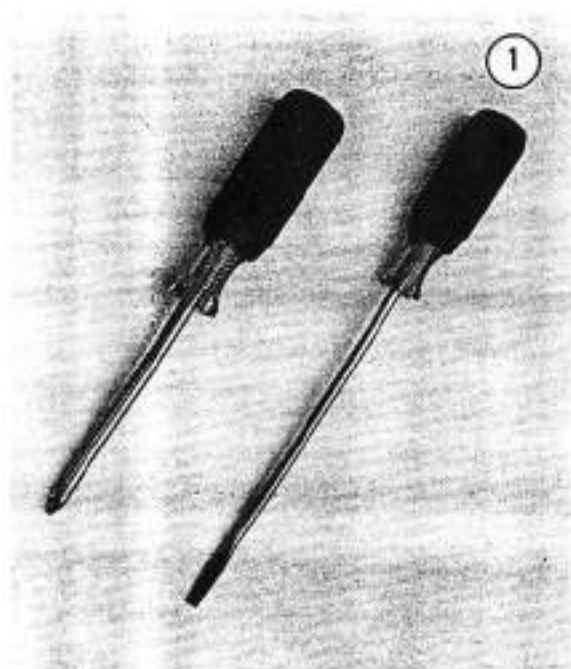

2

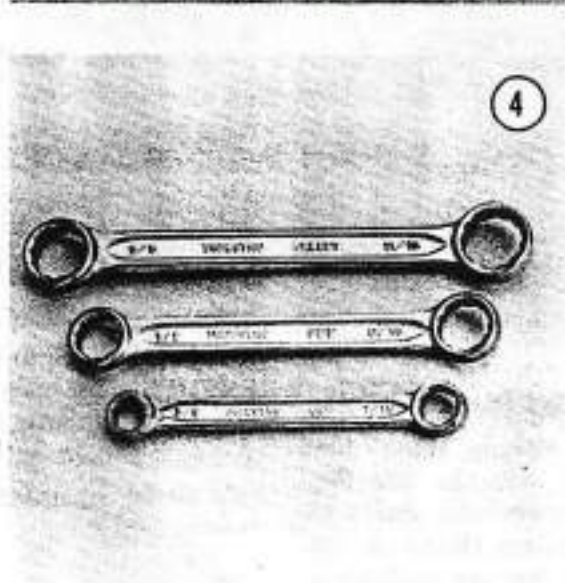

ADJUSTABLE (CRESCENT) WRENCHES

An adjustable wrench (also called crescent wrench) can be adjusted to fit nearly any nut or bolt head. See Figure 5. However, it can loosen and slip, causing damage to the nut. Use only when other wrenches are not available.

Crescent wrenches come in sizes ranging from 4-18 in. overall. A 6 or 8 in. is recommended as an all-purpose wrench.

SOCKET WRENCHES

This type is undoubtedly the fastest, safest, and most convenient to use. See Figure 6. Sockets which attach to a ratchet handle are available with 6-point or 12-point openings and $\frac{1}{4}$, $\frac{3}{8}$, $\frac{1}{2}$, and $\frac{3}{4}$ inch drives. The drivesize indicates the size of the square hole which mates with the ratchet handle. Sockets are available in metric and inch sizes.



5

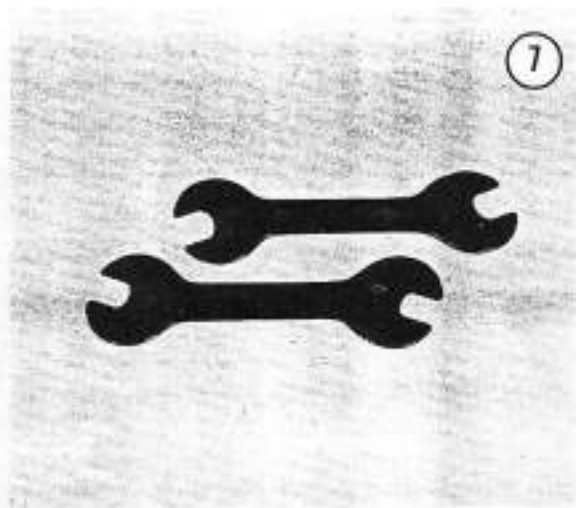

7

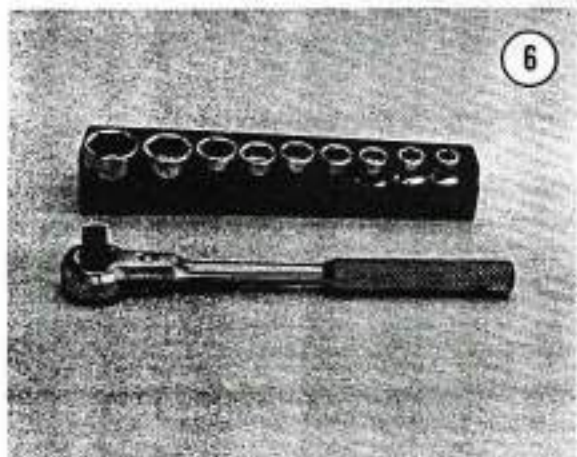

6

CONE WRENCHES

Cone wrenches are nothing more than especially thin open-end wrenches. See **Figure 7**. These wrenches are available separately or in sets of metric or inch sizes. Obtain the size required for your moped; they are available at most moped and bicycle dealers.

TORQUE WRENCH

A torque wrench is used with a socket to measure how tight a nut or bolt is installed. See **Figure 8**. They come in a wide price range and with either $\frac{3}{8}$ or $\frac{1}{2}$ in. square drive. The drive size indicates the size of the square drive which mates with the socket. An inexpensive one that measures from 1-100 ft.-lb. (0-140 N•m) retails for about \$15.



8

IMPACT DRIVER

This tool might have been designed with the moped in mind. See **Figure 9**. It makes removal of engine and clutch parts easy and eliminates damage to bolts and screw slots. A good one runs about \$15 at large hardware or auto parts stores.

IGNITION GAUGE

This tool measures point gap. It also has round wire gauges for measuring spark plug gap. See **Figure 10**. A good one runs about \$3 and is available at most auto or motorcycle supply stores.

TIRE LEVER

These are used to remove or install moped tires. See **Figure 11**. Check the working end of the tool before use and remove any burrs.

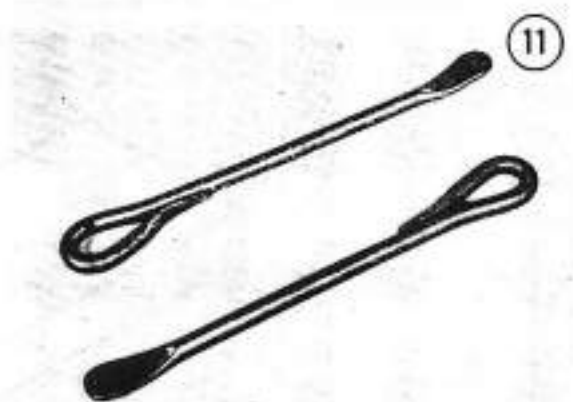
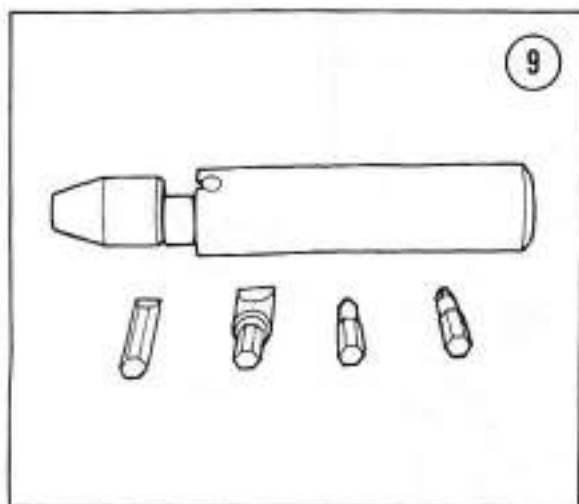

2

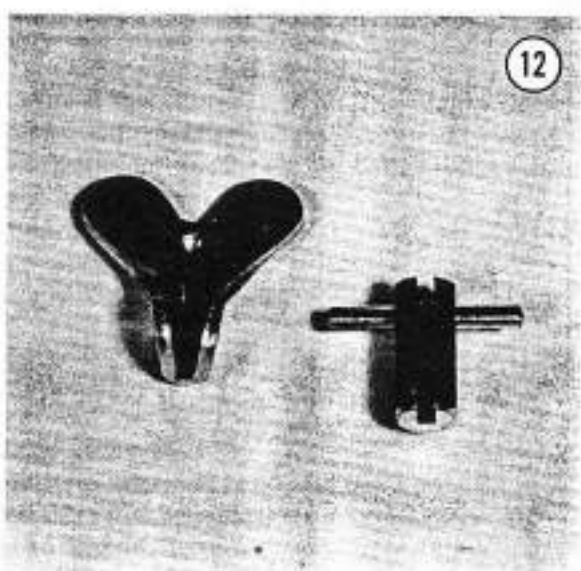
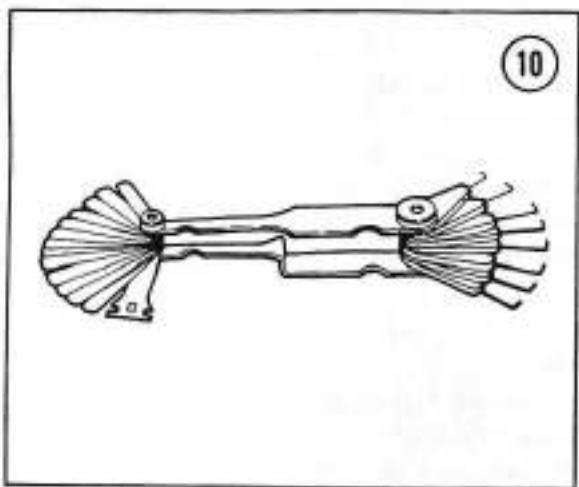

Never use a screwdriver in place of a tire lever. Chapter Ten explains its use.

SPOKE WRENCH

This special wrench is used to tighten spokes. See Figure 12. It is available at most moped or motorcycle supply shops.

CABLE CUTTER

A cable cutter is useful for cutting brake and accelerator cables. See Figure 13. Use the type with V-shaped jaws which shear the cable cleanly. Wire cutters which pinch the cable can be used, but they flatten the ends of the cable making it almost impossible to thread it into its housing.

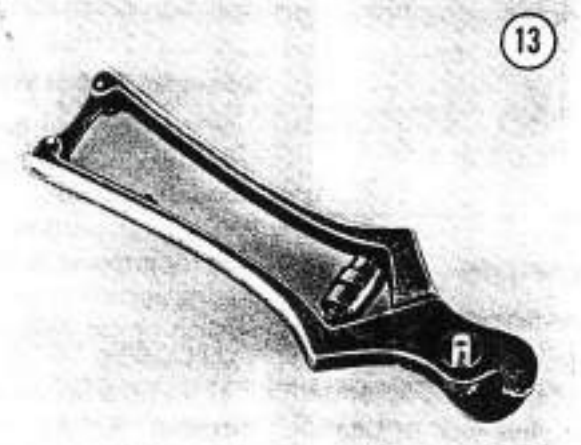

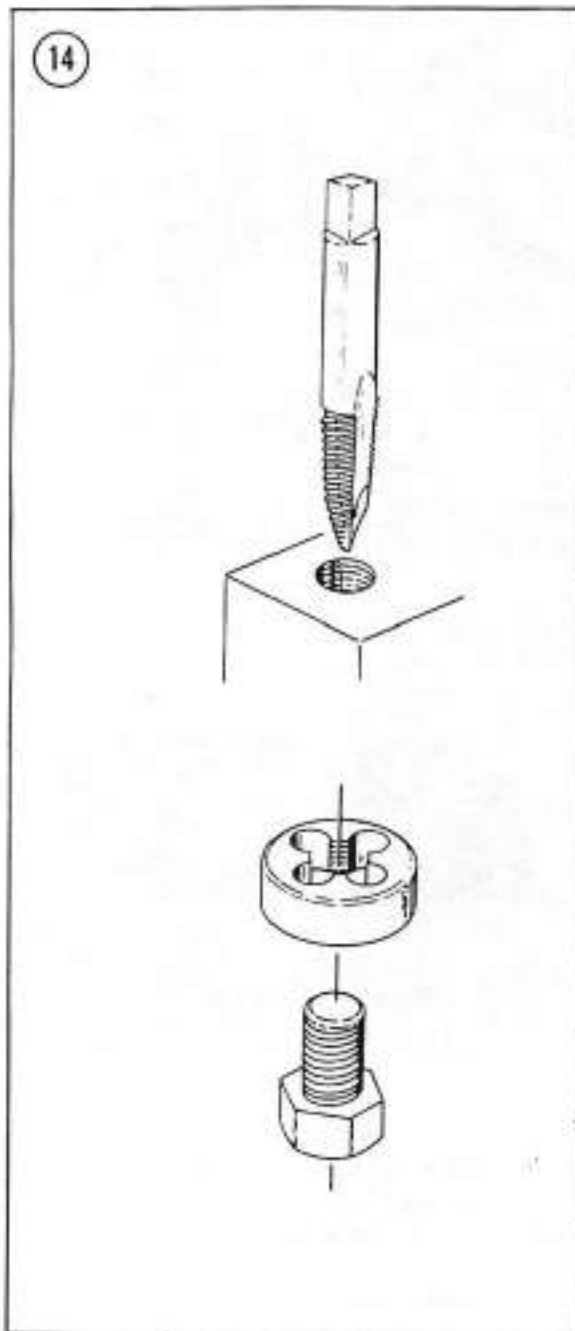

MECHANIC'S TIPS

Removing Frozen Nuts and Screws

When a fastener rusts and cannot be removed, several methods may be used to loosen it. First, apply penetrating oil such as Liquid Wrench or WD-40 (available at any hardware or auto supply store). Apply it liberally. Rap the fastener several times with a small hammer; don't hit it hard enough to cause damage.

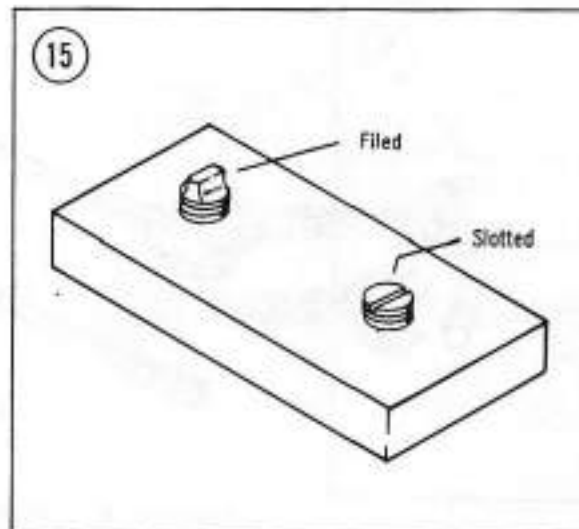

For frozen screws, apply penetrating oil as described, then insert a screwdriver in the slot and rap the top of the screwdriver with a hammer. This loosens the rust so the screw can be removed in the normal way. If the screw head is too chewed up to use a screwdriver, grip the head with Vise-Grip pliers and twist screw out.

Remedying Stripped Threads

Occasionally, threads are stripped through carelessness or impact damage. Often the threads can be cleaned up by running a tap (for internal threads on nuts) or die (for external threads on bolts) through the threads. See **Figure 14**.

Removing Broken Screws or Bolts

When the head breaks off a screw or bolt, several methods are available for removing the remaining portion.

If a large portion of the remainder projects out, try gripping it with Vise Grips. If the projecting portion is too small, try filing it to fit a wrench or cut a slot in it to fit a screwdriver. See **Figure 15**.

If the head breaks off flush, try using a screw extractor. To do this, centerpunch the exact center of the remaining portion of the screw or bolt. Drill a small hole in the screw and tap the extractor into the hole. Back the screw out with a wrench on the extractor. See **Figure 16**.

REMOVING BROKEN SCREWS AND BOLTS

16

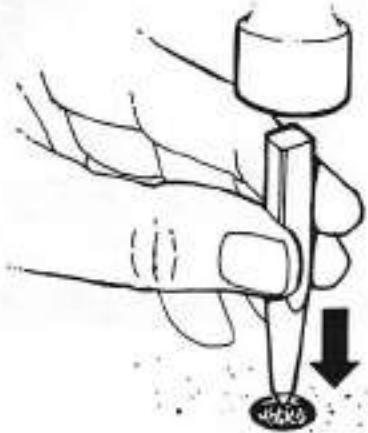

1. Center punch broken stud



2. Drill hole in stud



3. Tap in screw extractor

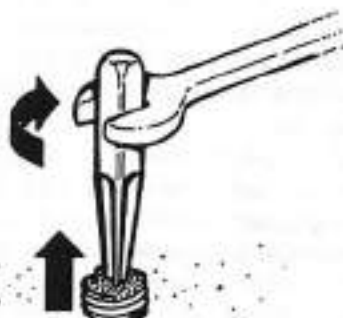

4. Remove broken stud

2

CHAPTER THREE

TUNE-UP, LUBRICATION, AND MAINTENANCE

If this is your first experience with an engine powered vehicle, you should become acquainted with products that are available in auto or motorcycle parts and supply stores. Look into the tune-up tools and parts, check out the different lubricants such as 2-stroke motor oil, chain cleaner, and oil and greases. Also check engine degreaser, like Gunk Cycle Degreaser, for cleaning your moped prior to working on it. See what is available to properly maintain the appearance such as polish and wax for the painted surfaces, Armor All for rubber and vinyl, and Simichrome for all plated, polished, and stainless parts.

The more you get involved with your moped the more you will want to work on it. Start out by doing the simple tune-up, lubrication, and maintenance. Tackle more involved jobs as you gain experience so that you will not get frustrated and discouraged.

A moped is a relatively simple machine but it does require periodic attention to keep it working properly. Without proper attention, you may soon face a number of expensive repairs.

Most expensive repairs can be prevented. A regular program of periodic inspection, lubrication, and maintenance will help find trouble before it becomes major and will actually prevent most trouble due to wear.

This chapter explains tune-up, periodic adjustments, maintenance, inspection, and lubrication required on all mopeds.

You can perform all of the procedures in less than one day. Considering the number of carefree, safe and enjoyable hours of riding possible with a well-maintained moped, maintenance time represents a "bargain" investment.

ENGINE TUNE-UP

The number of definitions of the term "tune-up" is probably equal to the number of people defining it. For purposes of this book, a tune-up is general adjustment and maintenance to insure peak engine power.

The following paragraphs discuss each facet of a proper tune-up which should be performed in the order given. Unless otherwise specified, the engine should be thoroughly cool before starting any tune-up service.

Spark Plug

Every 1,000 miles, or sooner if necessary, remove the spark plug. To remove the spark plug, first clean the area around its base to prevent dirt or other material from entering the cylinder. Next, remove the spark plug wire

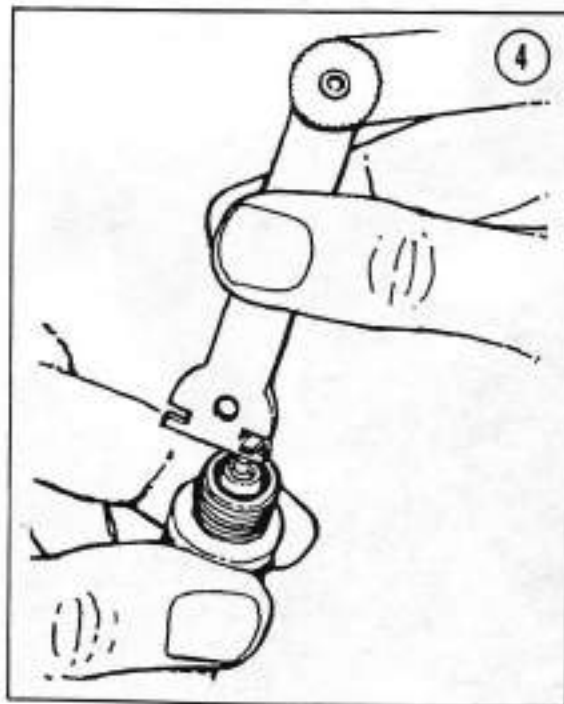
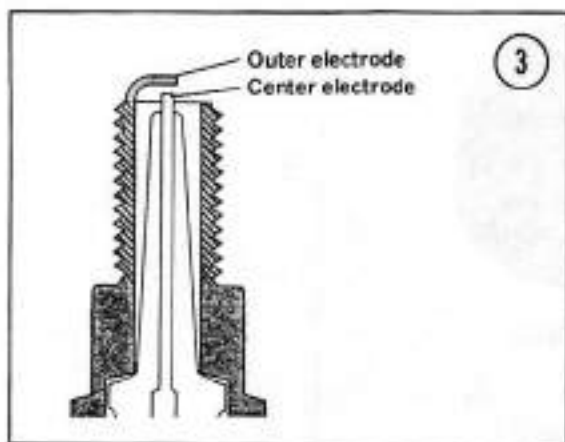
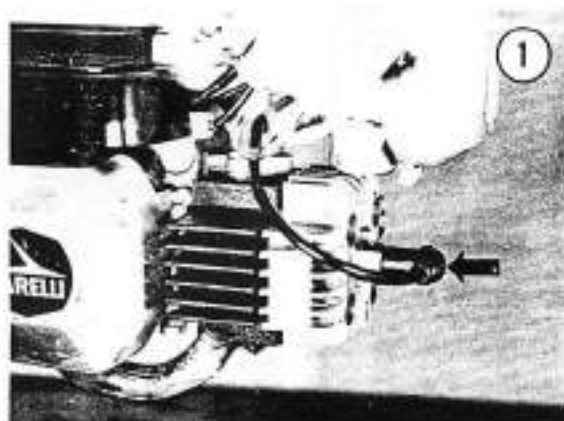

from the top of the spark plug (Figure 1) by pulling straight off. Unscrew the spark plug, using the spark plug wrench furnished with your moped or use a $\frac{1}{4}$ in. deep socket wrench. If difficulty is encountered removing the spark plug, apply penetrating oil like Liquid Wrench or WD-40 to its base and allow about 20 minutes for the oil to work in.

After removing the spark plug compare its condition with those shown in Figure 2. If the spark plug has a light tan or gray colored deposit and no abnormal gap wear or electrode erosion is evident, the engine is running properly. Clean the end that goes into the cylinder head with a wire brush. Inspect it for worn or eroded electrodes. These are the two points which the spark jumps (Figure 3). Replace the spark plug if there is any doubt about its condition. If the spark plug is OK, file the center electrode square, then adjust the gap by bending the outer electrode only with a spark plug gapper tool (Figure 4). Measure the gap with a round wire spark plug gauge as shown in Figure 5. Do not use a flat gauge as it will indicate an incorrect reading. The proper gap is 0.020 in. (0.5mm).

Before installing the spark plug, clean the seating area on the cylinder head and always use a new gasket. Install the plug only fingertight, then tighten it an additional one half turn with a spark plug wrench. Wipe off the top tip of the spark plug and install the spark plug wire.

It is a good idea to carry a spare spark plug with you at all times. Keep it in its original package to protect it. For proper spark plug refer to Table 1.

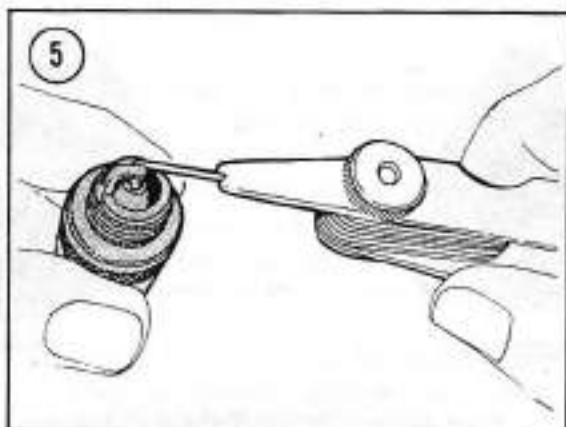

2

SPARK PLUG CONDITIONS



NORMAL USE



OIL FOULED



CARBON FOULED



OVERHEATED



GAP BRIDGED

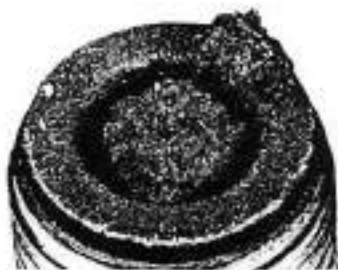

SUSTAINED PREIGNITION



WORN OUT

Photos courtesy of Champion Spark Plug Company.

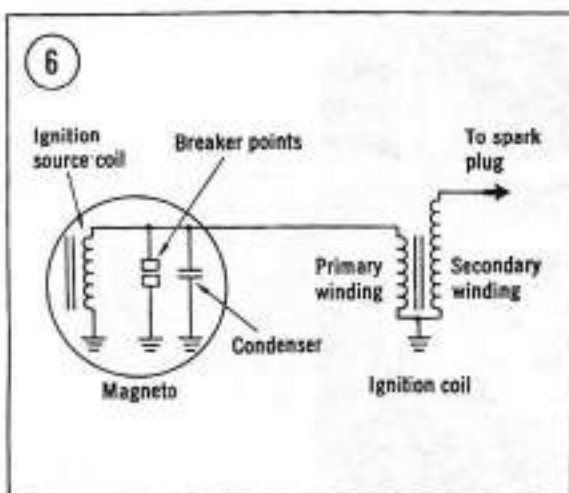

Table 1 SPARK PLUG SPECIFICATION

Version	Bosch	NGK	Champion
17 mph	W145T1	B5HS	L-89CM
20 mph	W145T1	B5HS	L-89CM
25 mph	W175T1	B6HS	L-82
30 mph	W225T1	B7HS	L-82

Magneto

The engine-mounted magneto generates electricity for the lights and spark plug. It works similar to a generator or alternator on an automobile, but is more compact and is attached directly to the engine.

Figure 6 illustrates the typical ignition circuit leading to the spark plug. Chapter Eight describes how it works in detail.

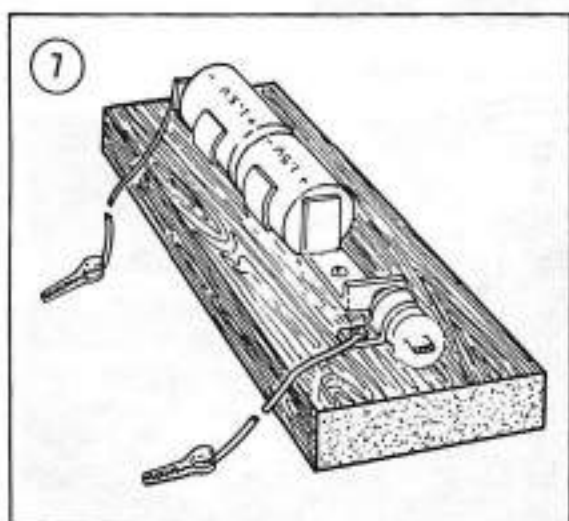

Magneto Ignition Timing and Breaker Point Adjustment

This procedure requires a test light. It can be a homemade unit (Figure 7) that consists of two C or D size flashlight batteries and a light bulb, all mounted on a piece of wood, some light gauge electrical wire, and alligator clips. These items can be purchased from any hardware store.

The following procedure is based on the test unit shown in Figure 7. If another type is used, follow the manufacturer's instructions.

1. On *Eureka*, *Sport*, *Gran Sport* and *Super Sport XL* models remove the rubber mat and the 4 bolts securing the engine fairing (Figure 8) and remove it. Remove the 4 screws securing the right-hand engine cover (Figure 9) and remove it.
2. On *Gran Sport Twin* models remove the 2 screws (Figure 10) securing the step place, and remove it. Remove the screw (Figure 10) securing the right-hand engine fairing and remove it.
3. On *Gran Sport Twin* models remove the right-hand crank arm as described under *Crankarm Removal/Installation* in Chapter Six.
4. On *Gran Sport Twin* models remove the 3 screws (Figure 11) securing the engine/magneto cover and remove it.

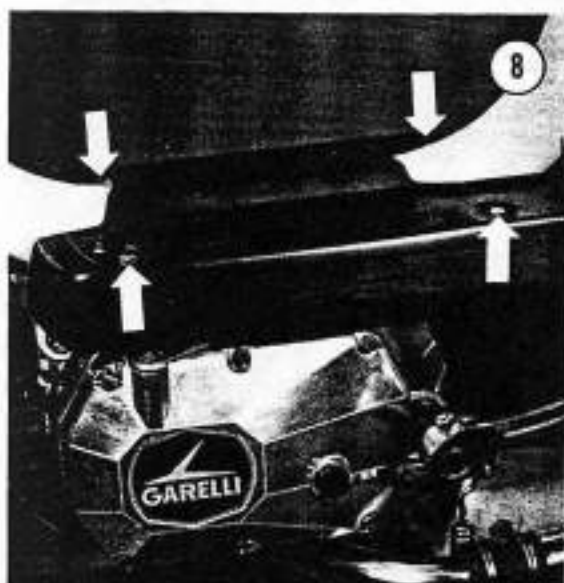

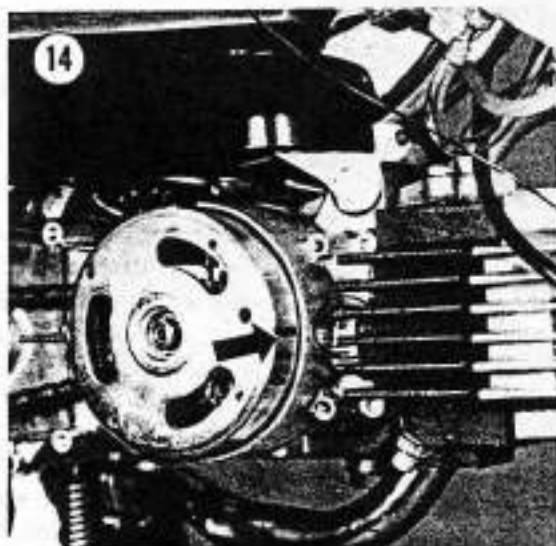
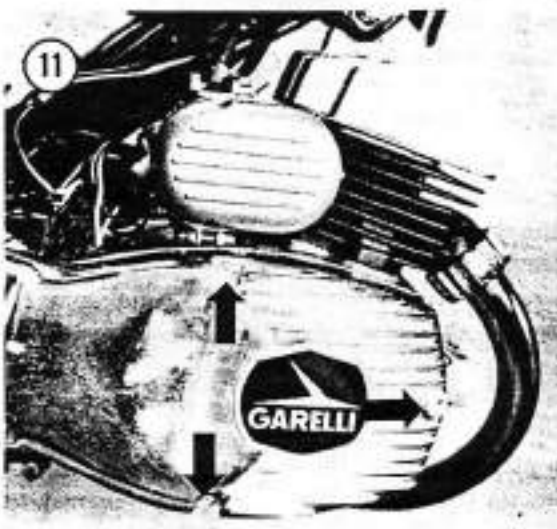
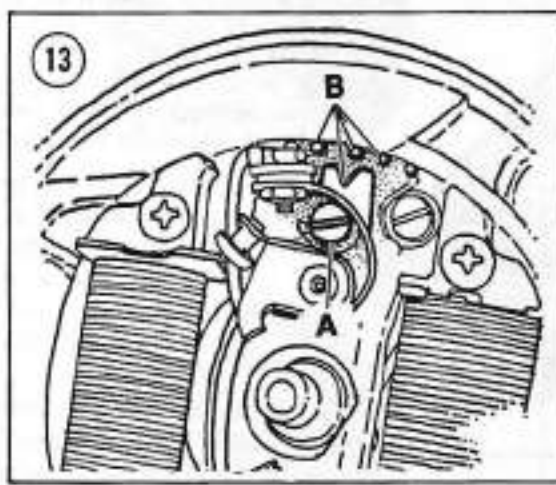
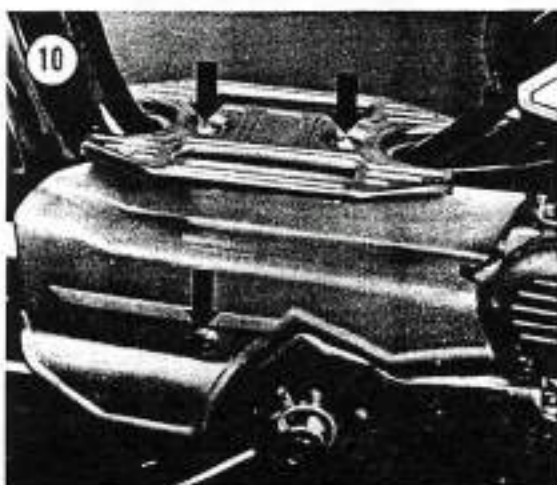
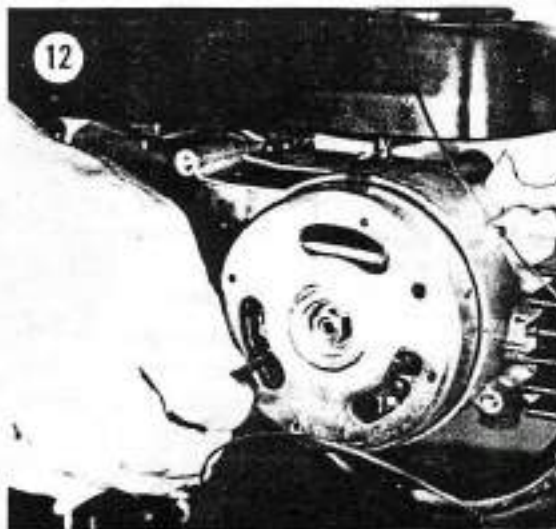
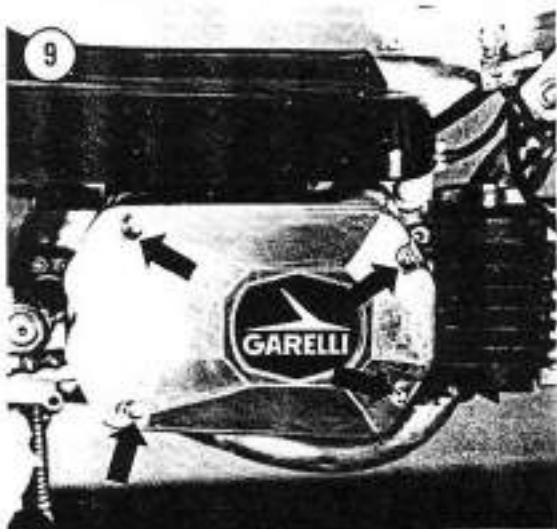

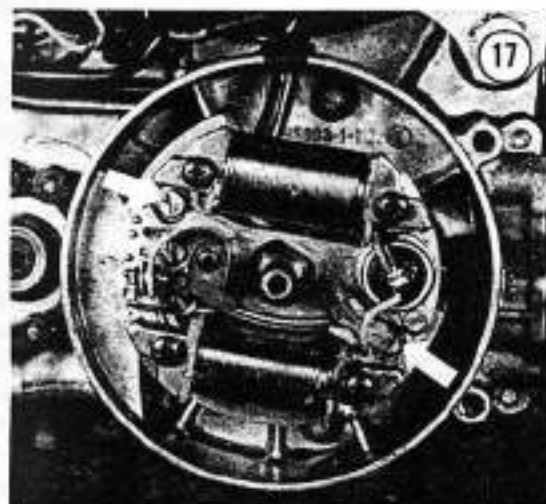
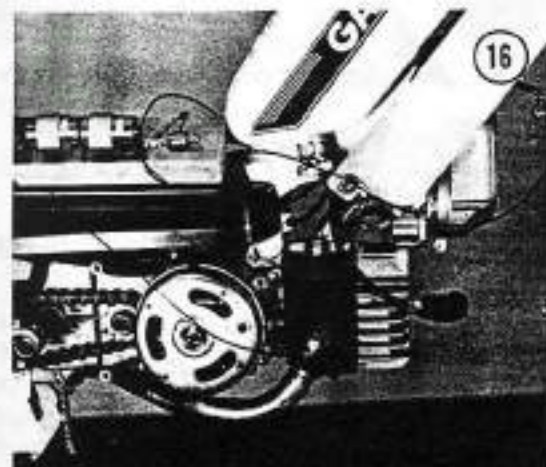
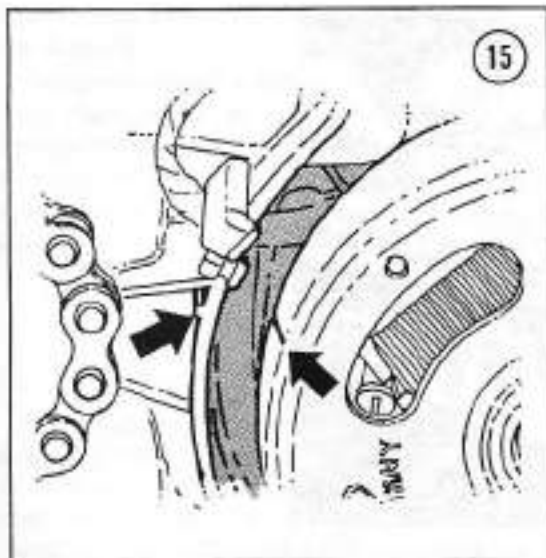

5. Turn the engine cut-off switch to the RUN position.

6. Rotate the rotor clockwise until the gap is open to maximum. The correct gap is 0.014-0.018 in. (0.35-0.45mm). Insert a flat feeler gauge between the points (Figure 12). If the setting is incorrect slightly loosen the breaker points attachment screw (A, Figure 13) and insert a screwdriver between the adjusting notches (B) and turn slightly until the breaker points start to drag on the feeler gauge, then tighten the adjusting screw (A) securely. Recheck the setting after securing the adjusting screw. The points are now adjusted correctly.

7. Disconnect the black magneto wire (going from the magneto to the high tension coil) at the terminal block. The terminal block is located above the magneto.

8. Align the timing marks on the rotor with the mark on the engine. See Figure 14 for Eureka, Sport, Gran Sport and Super Sport XL. See Figure 15 for Gran Sport Twin.

NOTE: Prior to attaching the tester, check the condition of the batteries by touching the two test leads together. The light should be ON. If not, replace the batteries and/or check all connections on the tester. Be sure the tester is operating correctly before using it.

9. Connect one lead of the test light (Figure 7) to a good ground like one of the cooling fins on the cylinder, and the other to the black magneto wire disconnected in Step 6 (Figure 16). The test light should now be ON but should be dim. The points should be open.

NOTE: Figure 17 (Eureka, Sport, Gran Sport and Super Sport XL) and Figure 18 (Gran Sport Twin) are shown with the magneto rotor removed for clarity. Do not remove it to perform this adjustment procedure.

10. Turn the rotor counterclockwise a little. The test light should now brighten; the points should be closed. If it does not, the base plate has to be adjusted. Loosen the screws (Figure 17 for Eureka, Sport, Gran Sport, Super Sport XL models and Figure 18 for Gran Sport Twin) securing the base plate to the stator and

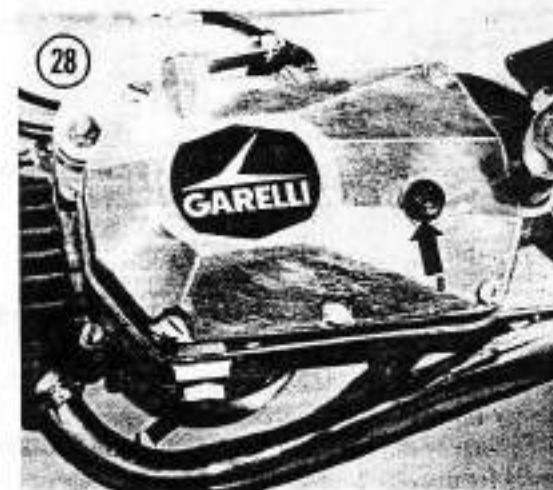
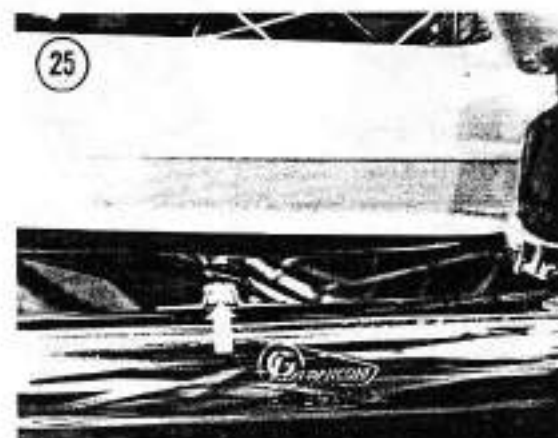
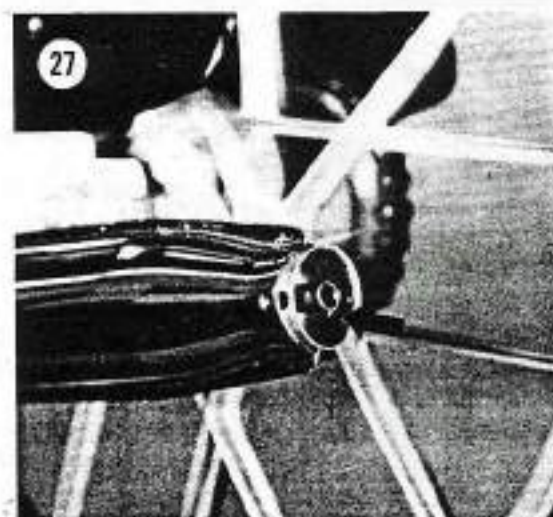
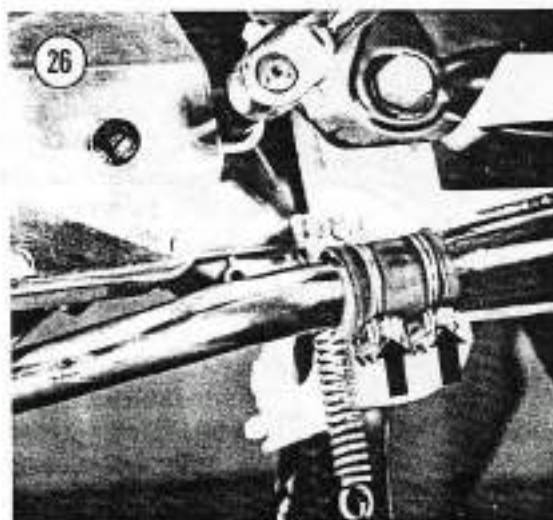

7. Blow out, with compressed air, all loose carbon deposits.
8. Inspect the muffler body and exhaust pipe to make sure it is not dented or cracked. Straighten out if possible or replace.
9. Assemble by reversing the removal steps. Always use a new gasket between the exhaust pipe and the cylinder.

LUBRICANTS

Oil

Oil is graded according to its viscosity, which is an indication of how thick it is. The Society of Automotive Engineers (SAE) system distinguishes oil viscosity by numbers, called "weights." Thick (heavy) oils have higher viscosity numbers than thin (light) oils. For example, a 5-weight (SAE 5) oil is a light oil while a 90-weight (SAE 90) oil is relatively heavy. The viscosity of an oil has nothing to do with its lubricating properties.

In this manual, many procedures specify light oil. This means an SAE 5 oil or equivalent.

Grease

Molybdenum disulphide grease is preferable as a lubricant for many parts of a moped. Water does not wash grease off parts as easily as it washes off oil. In addition, grease maintains its lubricating qualities better than oil on long rides. In a pinch, though, the wrong lubricant is better than none at all. Correct the situation as soon as possible.

A number of procedures in this manual specify thin grease. Lubriplate, a white grease, is highly satisfactory for mopeds and comes in a small tube for easy application.

CLEANING SOLVENTS

A number of solvents can be used to remove old dirt, grease, and oil. Kerosene is readily available and comparatively inexpensive. Another inexpensive solvent similar to kerosene is ordinary diesel fuel. Both of these solvents have a very high temperature flash point and can be used safely in any adequately ventilated area away from open flames.

WARNING

Never use gasoline. Gasoline is extremely volatile and contains tremendously destructive potential energy. The slightest spark from metal parts accidentally hitting, or a tool slipping, could cause a fatal explosion.

PERIODIC LUBRICATION

Front and Rear Wheel Hubs

Every 2,500 miles completely disassemble, clean, inspect, lubricate and reassemble the hubs as described under *Front and Rear Wheel Hubs Removal/Installation/Inspection* in Chapter Ten.

Front and Rear Brake Cams

Every 2,500 miles remove the front and rear wheels, remove brake plate assemblies and lubricate cams and pivot pins as described under *Brake Lining Removal/Installation* in Chapter Nine.

Clutch

Every 1,200 miles, drain and replace the clutch oil.

1. Place a drip pan under the clutch housing and remove the drain plug (A, **Figure 28**) and completely drain all oil. Let it drain at least 10 minutes.
2. Install the drain plug and remove the fill cap (B, **Figure 28**).
3. Fill with 13.5 oz (400 cc) SAE 30 *non-detergent oil*.

CAUTION

Do not use detergent oil.

NOTE: In order to measure the correct amount of oil use a plastic baby bottle. These have measured increments in fluid ounces (oz) and cubic centimeters (cc) on the side (Figure 29).

4. Install the fill plug, start the engine and check for leaks.

Cables

Every 1,500 miles, squirt a few drops of light oil on the brake, choke lever and start lever cables where they enter the cable housings.

Chain

Every 500 miles (more often in dusty areas), remove the chain. Clean and lubricate it as described under *Chain Cleaning and Lubrication* in Chapter Six.

Headset (Fork Bearings)

Every 2,500 miles remove the upper and lower headset bearings. Clean, inspect and lubricate them as described under *Headset Removal/Installation/Inspection*, Chapter Ten.

Front Forks

Every 4,000 miles disassemble, clean and lubricate the front forks as described under *Front Fork Disassembly/Assembly* in Chapter Ten.

Pedals

Every month squirt a few drops of 30 weight oil at the point where the pedal attaches to the crank arm.

PERIODIC MAINTENANCE

Drive Chain Adjustment

Every 2,000 miles the drive chain should be adjusted. Proper chain tension is important. If the tension is too loose, the chain may skip while traveling at high speed. If tension is too tight, pedaling, engine effort and chain wear increase.

The correct chain tension is measured by pressing up on the bottom of the chain at midpoint. The slack should be $\frac{7}{16}$ in. (11mm). See **Figure 30**. If the tension is incorrect, use the following adjustment procedure.

1. Loosen the rear axle locknuts (A, **Figure 31**).
2. Turn the adjusting cams (B **Figure 31**). Turning the cams *clockwise* will increase tension and *counterclockwise* will decrease the tension.
3. Check to see that the wheel is aligned within the center of the chainstays.
4. Rotate the wheel to make sure the tension in the chain is constant.
5. Tighten the rear axle locknuts (A, **Figure 31**) securely.

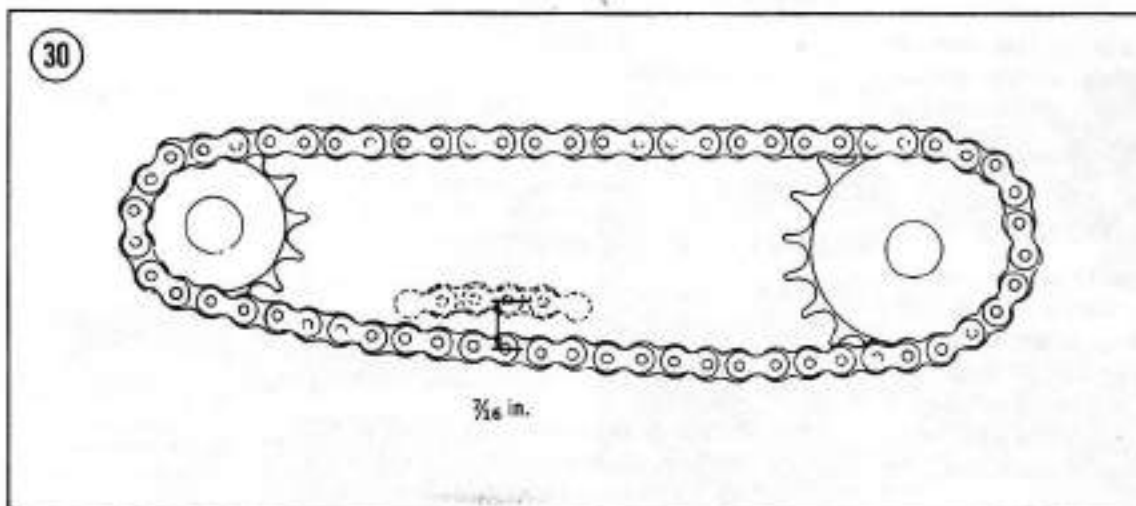
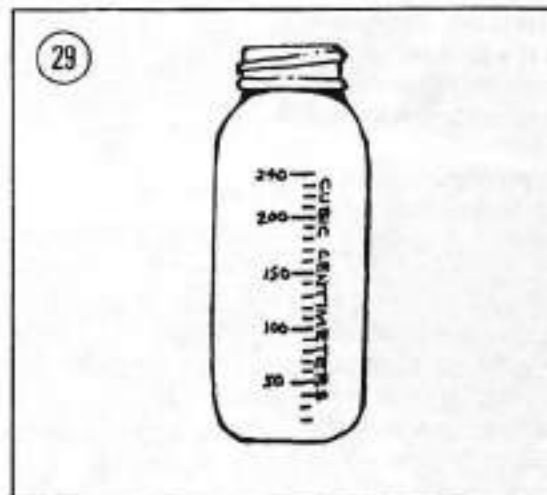

6. Check the rear brake operation as it may have to be adjusted. Refer to *Rear Brake Adjustment* in Chapter Nine.

Brake Adjustment

Figure 32 illustrates the major parts of the brakes. Squeezing the brake lever rotates the cam, which in turn forces the brake shoes out to contact the brake drum.

Every 500 miles, adjust the front and rear brake lever free play. Free play is the distance the brake lever travels between the released position and the point when the brake shoes come in contact with the drums, this should be kept to a minimum.

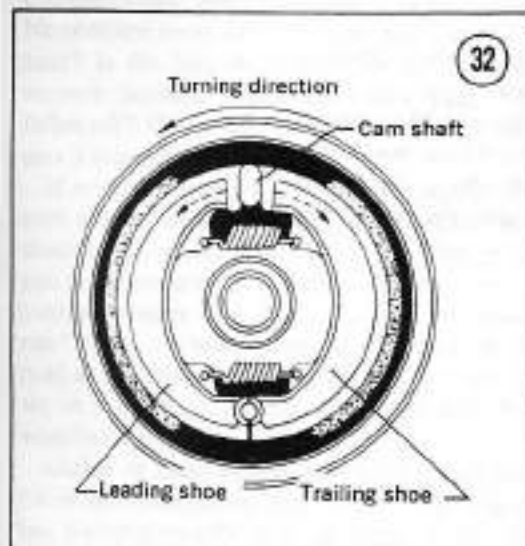
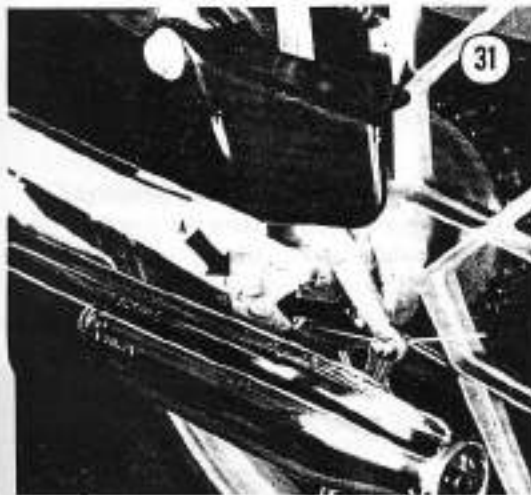

1. At the brake plate, turn the adjusting nut (A) at the end of the outer cable housing toward the end of the housing (Figure 33). This should take out the necessary slack.

2. If proper adjustment cannot be achieved by this method, loosen the cable clamp bolt (B, Figure 33) and turn the adjusting nut (A) in away from the end of the outer cable housing.

3. Pull on the end of the cable until it is taut, tighten the cable clamp bolt (B). If necessary, repeat Step 1.

NOTE: If proper adjustment cannot be achieved by using both of these methods, the cable will have to be replaced. See *Brake Cable Removal/Installation* in Chapter Nine.

Clutch Start Cable Adjustment

The start lever cable should be checked periodically to maintain free play. Free play is the distance the start lever travels between the release position and the point when the lever, on the engine cover, engages the clutch mechanism. This should be kept to a minimum.

Adjust free play by loosening the locknut (A) and turning the adjusting barrel (B) clockwise to reduce slack in the cable (Figure 34).

If proper adjustment cannot be achieved, cable will have to be replaced. See *Clutch Start Lever Cable Removal/Installation*, Chapter Six.

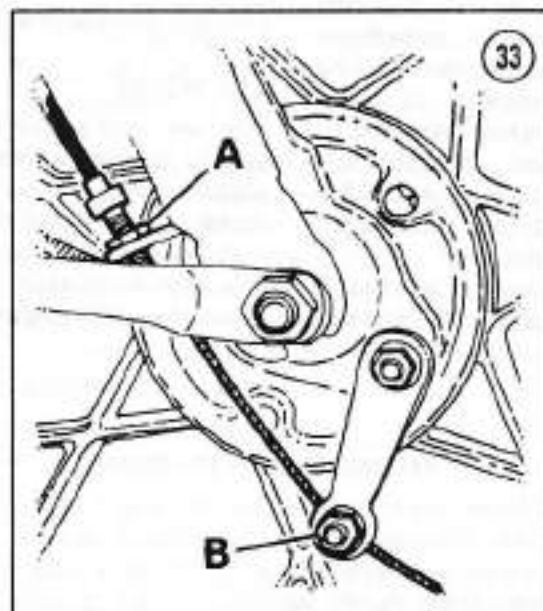

3

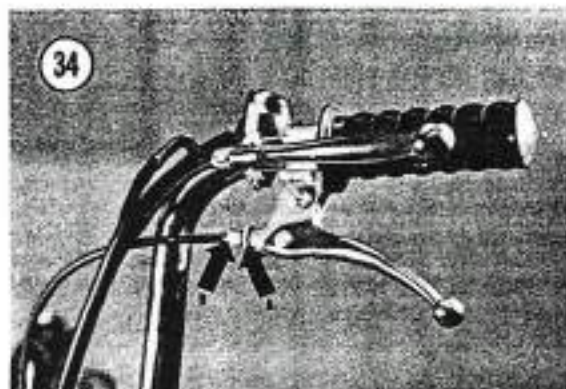

Front Forks

Every 4,000 miles, disassemble, clean and lubricate the front forks as described under *Front Fork Disassembly/Assembly*, Chapter Ten.

Wheels and Tires

Every 400 miles, check the wheels for bent or damaged rims and loose or missing spokes. Refer to Chapter Ten for complete wheel information.

Spokes

Spokes should be checked periodically for looseness or bending. Check spokes for proper tension. The "tuning fork" method for checking tension is simple and works well. Tap each spoke with a spoke wrench or screwdriver shank. A taut spoke will emit a clear, ringing tone; a loose spoke will sound flat. All spokes in a correctly tightened wheel will emit tones of similar pitch, but not necessarily the same tone. Bent, stripped or otherwise damaged spokes should be replaced as soon as they are detected. See Chapter Ten for procedure.

Spokes tend to loosen as the moped is used. If they are loose, retighten each spoke one turn,

beginning with those on one side of the hub, then those on the other side. Tighten the spokes of a new moped after the first 50 miles of operation and then at 50 mile intervals until they no longer loosen.

Fasteners

Every 1,000 miles, check all nuts, screws and bolts that secure parts to the frame, e.g., engine fairing, lights, fenders, etc., to make sure they are tight.

Extended Storage

If you store the moped for an extended period of time, prepare your moped in the following way.

1. Empty the fuel tank completely.
2. Run the engine until the carburetor is empty.
3. Remove the spark plug and put a few drops of oil into the cylinder.
4. Turn the engine over by pedaling to spread the oil around in the cylinder.
5. Install the spark plug, only finger-tight and connect the spark plug wire.
6. Clean and lubricate all parts.
7. Dampen a cloth with light weight oil and wipe all metal parts or spray them with a light coat of WD-40. This will help protect against rust.
8. Cover the moped with a tarp or blanket.

After Storage

Before starting the engine after storage, remove the spark plug and squirt a small amount of fuel into the cylinder to help remove the oil coating. Install the spark plug but do not connect the spark plug wire. Pedal the engine over a few times, then reconnect the spark plug wire and start the engine.

CHAPTER FOUR

TROUBLESHOOTING

4

Diagnosing mechanical problems is relatively simple if you use orderly procedures and keep a few basic principles in mind.

The troubleshooting procedures in this chapter analyze typical symptoms, and show logical methods of isolating causes. These are not the only methods. There may be several ways to solve a problem, but only a systematic, methodical approach can guarantee success.

Never assume anything. Do not overlook the obvious. If you are riding along and the moped suddenly quits, check the easiest, most accessible problem spots first. Is there gasoline in the tank? Is the fuel shutoff valve in the **ON** or **RESERVE** position? Has the spark plug wire fallen off? Check the ignition switch to make sure it is in the **RUN** position.

If nothing obvious turns up in a quick check, look a little further. Learning to recognize and describe symptoms will make repairs easier for you or a mechanic at the shop. Describe problems accurately and fully. Saying "it won't run" is not the same as saying, "it quit on the road at low speed and won't start," or that "it sat in my garage for three months and then wouldn't start."

Gather as many symptoms together as possible to aid in diagnosis. Note whether the engine lost power gradually or all at once, what color

smoke (if any) came from the exhaust, and so on. Remember that the more complicated a machine is, the easier it is to troubleshoot because symptoms point to specific problems.

After the symptoms are defined, areas which could cause the problems are tested and analyzed. Guessing at the cause of a problem may provide the solution, but it can easily lead to frustration, wasted time and a series of expensive, unnecessary parts replacement.

You do not need fancy equipment or complicated test gear to determine whether repairs can be attempted at home. A few simple checks could save a large repair bill and time lost while the moped is in a dealer's service department. On the other hand, be realistic and do not attempt repairs beyond your abilities. Service departments tend to charge heavily for putting together a disassembled engine that may have been abused. Some won't even take on such a job — so use common sense, don't get in over your head.

OPERATING REQUIREMENTS

An engine needs three basics to run properly: correct fuel/air mixture, compression and a spark at the right time. If one or more are missing, the engine won't run. The electrical system

is the weakest link of the three basics. More problems result from electrical breakdowns than from any other source. Keep that in mind before you begin tampering with carburetor adjustment and the like.

If a moped has been sitting for any length of time and refuses to start, check and clean the spark plug and then look to the gasoline delivery system. This includes the tank cap, tank, fuel shutoff valve, lines and the carburetor. Rust may have formed in the tank, obstructing fuel flow. Gasoline deposits may have gummed up the carburetor jet and air passages. Gasoline tends to lose its potency after standing for long periods. Condensation may contaminate it with water. Drain old gas and try starting with fresh gasoline; don't forget to add the proper amount of 2-stroke oil.

EMERGENCY TROUBLESHOOTING

When the moped is difficult to start or won't start at all, it does not help to continue kicking the pedal down or to kick the tires. Check the obvious problems even before getting out your tools. Go down the following list step-by-step. Do each one; you may be embarrassed to find your cutoff switch in the OFF position, but that is better than wearing out your legs trying to get it started. If the moped still won't start, refer to the appropriate troubleshooting procedures which follow in this chapter.

1. Is there fuel in the tank? Remove the gas cap and rock the moped; listen for the fuel sloshing around.

WARNING

Do not use an open flame to check in the tank. A serious explosion is certain to result.

2. Is the fuel shutoff valve in the ON position? Turn it to RESERVE to be sure that you get the last remaining gas.

3. Is the choke in the right position? Lever on the carburetor should be depressed for starting a cold engine, up for a warm engine.

4. Is the engine cutoff switch in the ON position?

ENGINE

Starting Problems

Check first to see if there is sufficient gas. Open the gas cap and check for gas in the tank by rocking the moped and listening for the gas to slosh around. If gas is present in tank, remove the fuel line from the carburetor and see if the gas is flowing through the line. If not, check the fuel shutoff valve to make sure it is in the ON or RESERVE position. With the fuel shutoff valve in the ON position and still no gas present in the line there may be dirt or foreign matter in the fuel line or it may be kinked.

There may also be water in the fuel or the jet in the carburetor may be clogged. Check to see that vent hole in fuel cap (Figure 1) is clean and that fuel filter in carburetor is clean. Do not forget to use the choke in trying to start a cold engine. If there is sufficient fuel to the carburetor, next check out the electrical system.

Check that the engine cutoff switch is in the RUN position and that the spark plug wire is on tight. If both are OK next remove the spark plug and inspect it. Either clean and regap or replace it with a new one. Connect the spark plug wire to the spark plug and lay the spark plug on the cylinder head. Make sure that the base of the plug makes good contact. Kick the pedal as though you were trying to start the moped; there should be a big bright blue spark at the tip of the electrode. If there isn't a spark

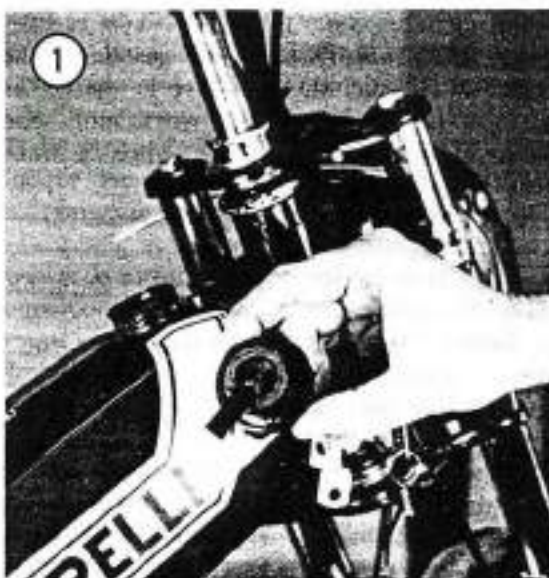

or if the spark is small, then there is an electrical problem.

Check that the spark plug wire is not broken or frayed or does not have a loose connection at the spark plug or magneto. If these seem to be all right then check the magneto. The timing may be off, the contacts may be dirty, the condenser worn out or the wire grounded, or the ignition coil may be shorted or open. If any of these problems are evident, refer to Chapter Eight for procedures and adjustments.

If there is a good healthy spark and fuel to the carburetor, check to make sure the air cleaner is clean and that the carburetor jet is clean. Make sure that the intake manifold nuts are tight and the carburetor clamp to intake manifold is tight. Check that the gasket between the carburetor and intake manifold is not broken or cracked. Replace it if necessary.

Check that the start lever cable is adjusted properly to engage the clutch while starting.

Rough Idle

Rough idle is probably caused by incorrect ignition timing, carburetor adjustment, a clogged muffler, or a vacuum leak from loose connections at the carburetor.

Power Loss

The ignition system may have a defective spark plug, ignition coil or condenser or the timing may be off. The carburetor may be dirty, misadjusted, have the wrong jet size or a dirty air filter. The engine may have worn piston rings, damaged cylinder, or it may need decarbonization. The muffler opening may be clogged by mud or it may need to be decarbonized. Check also for improper chain tension.

If the engine runs all right when on the centerstand but has no power when ridden, check the rear wheel bearings for lack of lubrication or damage. Refer to *Front and Rear Wheel Hubs Removal/Installation*, Chapter Ten.

Misfires

This is usually caused by a weak or fouled spark plug or a breakdown of the spark plug wire. Check to see if a spark "jumps" out from

the plug wire to any part of the frame before it gets to the plug. This is best done at night or in a dark garage.

Smoking or Sputtering

This is usually caused by insufficient burning of the fuel or an improper gasoline/oil mixture. Check for a fouled spark plug, clogged muffler or air filter or too much oil in the fuel mixture.

Overheating

This can be caused by too high a spark plug heat range, the percentage of oil in fuel mixture too low, clogged or dirty cooling fins on the engine cylinder and cylinder head, incorrect ignition timing, or carbonized engine or muffler. Also check for dragging brakes, a slipping clutch or a drive chain that needs oil or is adjusted too tight.

Piston and Engine Seizure

Piston seizure is caused by improper piston to cylinder clearance, broken piston rings or insufficient oil in the fuel/oil mixture. Engine seizure may be caused by a seized piston, broken or seized crankshaft bearings, smashed flywheel magneto cover, buckled magneto, or magneto stator screw caught between coil and rotor.

Backfiring

Ignition timing incorrect, engine too cold, defective spark plug or contaminated fuel may be the cause of backfiring. Also check for heavy carbon buildup on the piston and cylinder head.

Engine Noises

Abnormal engine noises are very difficult to describe and diagnose. Knocking may indicate a loose crankshaft assembly caused by bad bearings or a loose or broken engine to frame bracket. Also the clutch drum may be loose on the crankshaft. A slapping noise usually comes from a loose piston. A slamming noise may be caused by an unriveted flywheel magneto cam, damaged cylinder caused by overheating, or faulty clutch parts. A rubbing noise may be

from the flywheel magneto rotor being bent or out of true, or the cover and rotor touching each other. Pinging is caused by improper ignition timing or gasoline octane rating too low. If pinging is occurring, it should be corrected immediately as it will cause piston damage. A whistling noise may come from a defective crankcase seal, loose or damaged bearings, air leaking around the carburetor or intake manifold or magneto breaker cam needing lubrication.

Engine Vibration

Check to see if the engine mounting bolts are loose or broken. Vibration may be caused by worn engine and clutch bearings or an unbalanced rotor in the magneto.

CLUTCH

Clutch slippage may be due to a low oil level or contaminated oil in the clutch housing. Add oil or drain and refill. Also engine idle may be set too high.

BRAKES

Loss of braking power is due to worn out linings or improper cable adjustment. If brakes grab there is probably oil or grease on the linings and they will have to be replaced. If they stick, the return springs may be weak or broken, the pivot cams may need lubrication or the cables may need adjusting. Brake grabbing may also be caused by out-of-round drums, broken or glazed brake shoes or no "lead angle" on the leading edges of the brake lining (**Figure 2**). Refer to *Brake Lining Removal/Installation* in Chapter Nine.

ELECTRICAL

Lighting and Horn

Dimness of lights is usually caused by a loose bulb in the socket, corroded bulb contacts, loose or corroded electrical terminal connections, incorrect bulb size, bare wires which will short out, or improperly working magneto.

Check the horn for loose or corroded electrical connections.

Be sure to thoroughly check all electrical and ground connections before replacing light bulb or horn.

SUSPENSION

Hard steering may be caused by improper tire inflation, improper adjustment, or lack of lubrication of the steering head bearings. Wheel shimmy or vibration is caused by misaligned wheels, loose or broken spokes, or worn wheel bearings. Poor handling may be caused by worn shock absorbers, front forks needing lubrication, or damaged frame and rear swing arm.

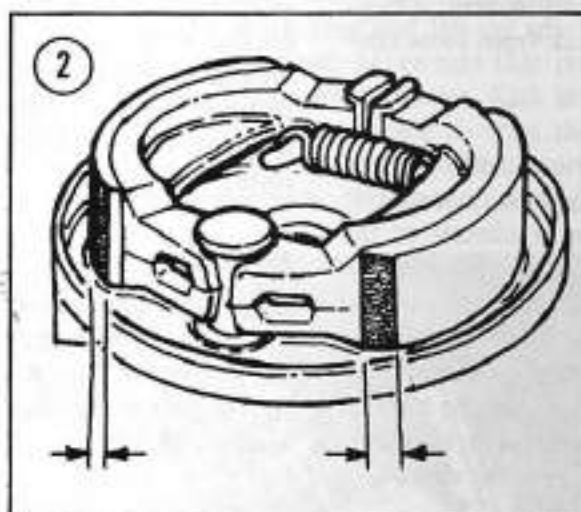

CHAPTER FIVE

ENGINE

5

The engine in the moped is a single cylinder, 2-stroke, piston port air-cooled unit with a displacement of 2.99 cu. in. (49cc). See **Figures 1 and 2**. This chapter contains information for removal, inspection, service and reassembly of the engine. The majority of the work can be accomplished without removing the entire engine from the frame, with the exception of a complete overhaul.

Service procedures for the different engines are virtually identical. Where there are differences, they are identified.

ENGINE PRINCIPLES

Figure 3 explains how the engine works. This is helpful when troubleshooting or repairing your engine.

ENGINE LUBRICATION

Lubrication for the engine is provided by the fuel/oil mixture used to power the engine. There is no oil supply in the crankcase as it would be drawn into the cylinder causing the spark plug to foul. There is sufficient oil in the fuel/oil mixture to lubricate the engine bearings as it is drawn into the crankcase.

On models *without* the oil injector, the proper fuel/oil mixture for the first 500 miles

(break-in period) is 26 parts of *regular gasoline* to one part of *2-stroke motor oil* (26:1 ratio). Thereafter, it is 32 parts of *regular gasoline* to one part of *2-stroke motor oil* (32:1 ratio).

On models equipped with the oil injector, fill the fuel tank with regular gasoline (0.70 gal.), unscrew the knob (A, **Figure 4**) and operate the actuator rod (**Figure 5**) on full cycle. One full cycle is one complete pull and one complete push. This will inject the correct amount of oil into the tank. This fuel/oil mixture has a ratio of 64:1.

CAUTION

The oil injector must be filled with Garelli 2-stroke Engine Lubricant, Golden Spectro or equivalent. Use of any other type of 2-stroke oil will void any applicable warranty.

To fill the oil injector, remove the fill cap (B, **Figure 4**) and refill. Replace the fill cap.

ENGINE COOLING

Cooling is provided by air passing over the cooling fins on the engine cylinder head or cylinder. Therefore it is very important to keep these fins free from a buildup of dirt, oil, grease and other foreign matter. Brush out the fins with a whisk broom or small stiff paint-brush.

①

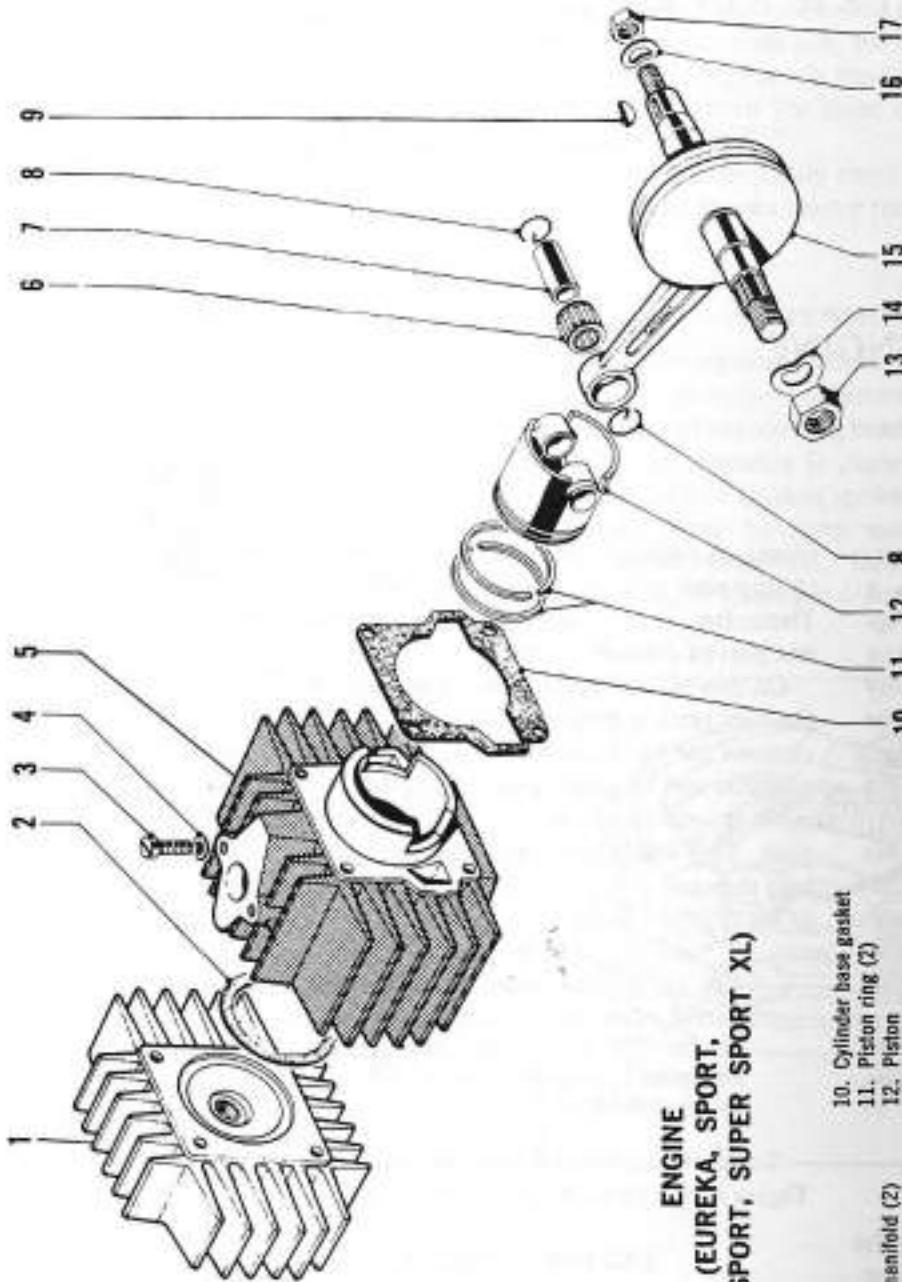

**ENGINE
(EUREKA, SPORT,
GRAN SPORT, SUPER SPORT XL)**

- | | |
|---------------------------------|--|
| 1. Cylinder head | 10. Cylinder base gasket |
| 2. Head gasket | 11. Piston ring (2) |
| 3. Bolt — intake manifold (2) | 12. Piston |
| 4. Washer — intake manifold (2) | 13. Nut — clutch side |
| 5. Cylinder | 14. Washer — clutch side |
| 6. Wrist pin bearing | 15. Crankshaft/connecting rod assembly |
| 7. Wrist pin | 16. Washer — magneto side |
| 8. Snap ring (2) | 17. Nut — magneto side |
| 9. Woodruff key | |

**ENGINE
(GRAN SPORT TWIN)**

1. Cylinder head
2. Rubber grommet
3. Bushing
4. Head gasket
5. Snap ring (2)
6. Wrist pin
7. Piston
8. Piston ring (2)
9. Cylinder
10. Cylinder base gasket
11. Washer — intake manifold (2)
12. Bolt — intake manifold (2)
13. Wrist pin bearing
14. Nut — clutch side
15. Washer — clutch side
16. Crankshaft/connecting rod assembly
17. Woodruff key
18. Washer — magneto side
19. Nut — magneto side

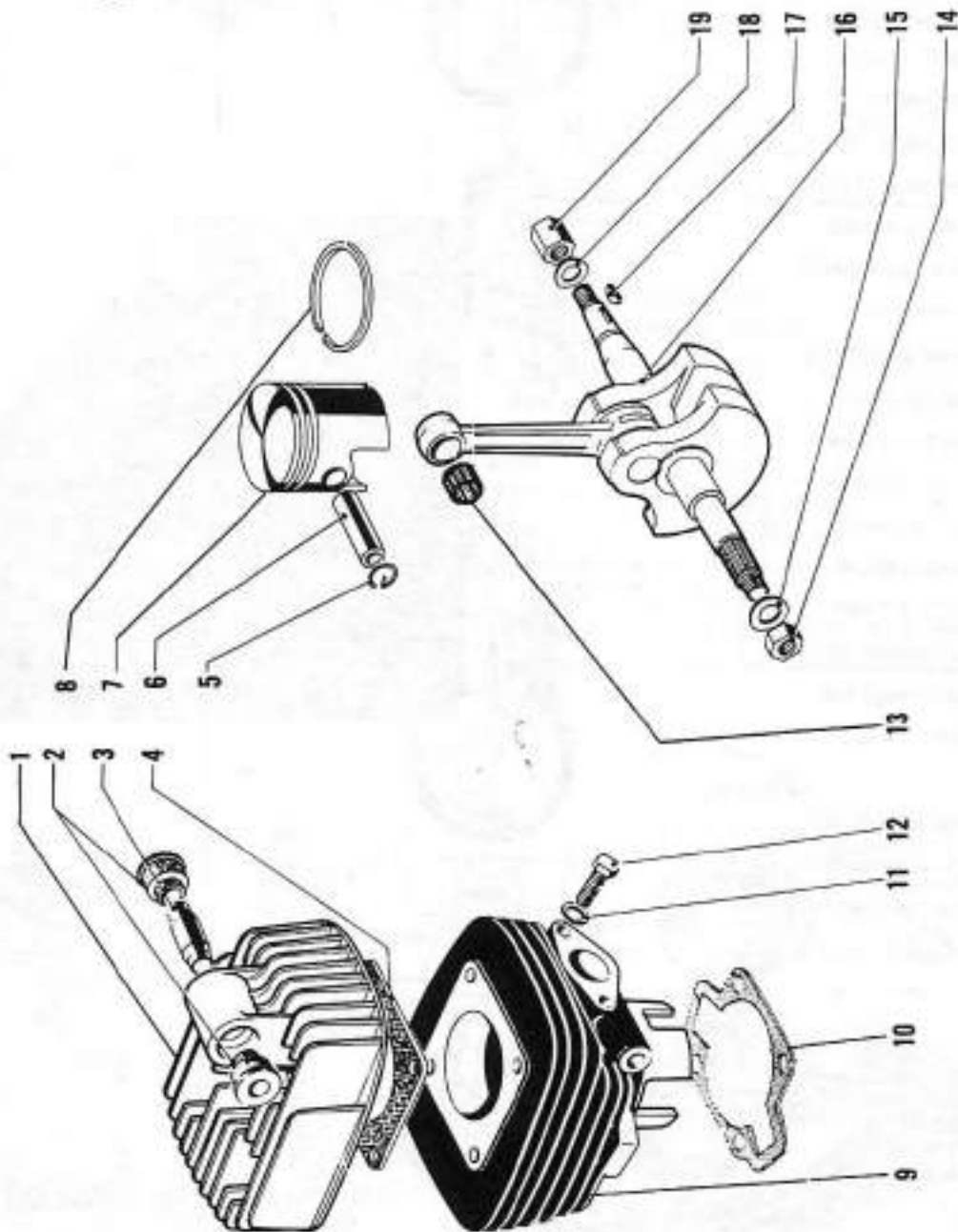

②

3

2-STROKE OPERATING PRINCIPLES

The crankshaft in this discussion is rotating in a counterclockwise direction.

As the piston travels downward, it uncovers the exhaust port (A) allowing the exhaust gases, that are under pressure, to leave the cylinder. A fresh fuel/air charge, which has been compressed slightly, travels from the crankcase into the cylinder through the transfer port (B). Since this charge enters under pressure, it also helps to push out the exhaust gases.

While the crankshaft continues to rotate, the piston moves upward, covering the transfer (B) and exhaust (A) ports. The piston is now compressing the new fuel/air mixture and creating a low pressure area in the crankcase at the same time. As the piston continues to travel, it uncovers the intake port (C). A fresh fuel/air charge, from the carburetor (D), is drawn into the crankcase through the intake port, because of the low pressure within it.

Now, as the piston almost reaches the top of its travel, the spark plug fires, thus igniting the compressed fuel/air mixture. The piston continues to top dead center (TDC) and is pushed downward by the expanding gases.

As the piston travels down, the exhaust gases leave the cylinder and the complete cycle starts all over again.

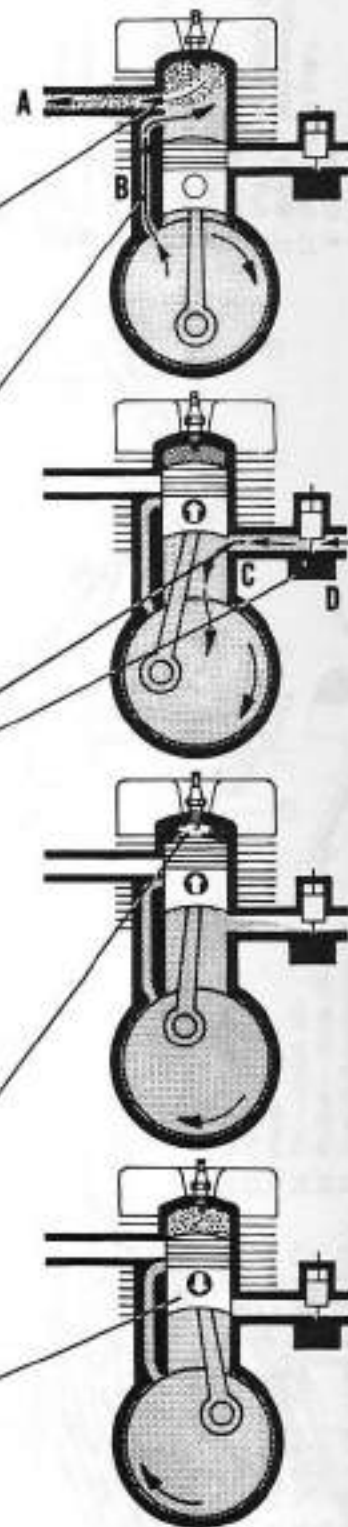

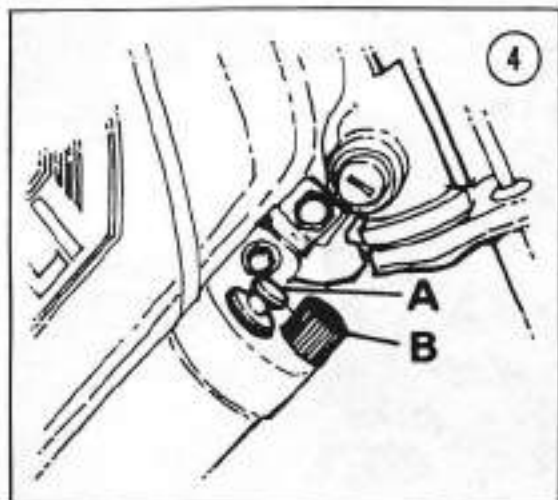

fin with a whisk broom or small stiff paintbrush.

CAUTION

Remember these fins are thin, in order to dissipate heat, and may be damaged if struck hard.

ENGINE REMOVAL/INSTALLATION

Prior to removal or disassembly of any major part of the engine, clean the entire area of all dirt, oil, grease and other foreign matter with Gunk Cycle Degreaser or equivalent. Follow the manufacturer's directions and avoid using too high a water pressure when rinsing off the engine. Keep water and dirt from entering into the clutch and brake areas.

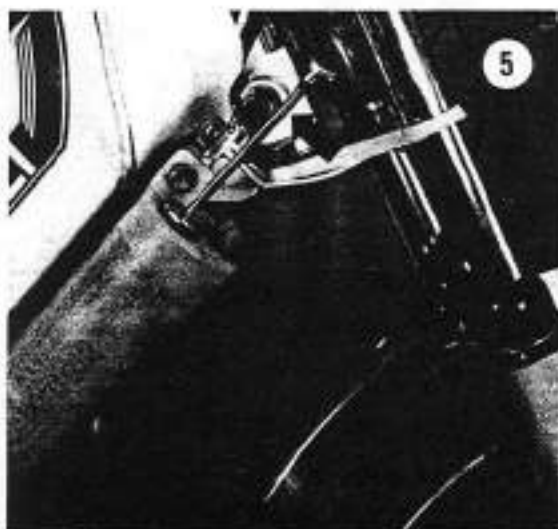

Model — Eureka, Sport, Gran Sport, Super Sport XL

1. Place the moped on the centerstand.
2. Remove the rubber mat and remove the 4 bolts securing the engine fairing (Figure 6) and remove it.
3. Place a drip pan under the clutch housing, remove the drain plug (Figure 7) and completely drain the oil. Let it drain for at least 10 minutes. Install the drain plug.
4. Push in on the clutch start arm (Figure 8) and unhook the end of the clutch cable (Figure 9).

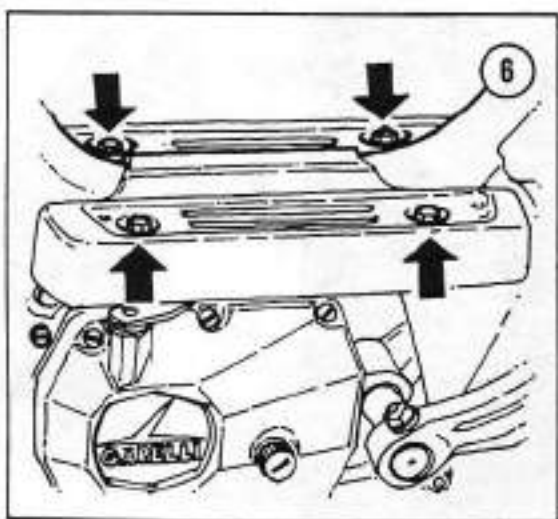

5. Remove the spark plug wire and the spark plug (Figure 10).
6. Remove the 2 Allen head bolts securing the exhaust pipe to the cylinder (Figure 11). Remove the 2 bolts securing the muffler at the rear (Figure 12) and remove the muffler and exhaust pipe.
7. Remove the crank arms as described under *Crank Arm Removal/Installation*, Chapter Six.

NOTE: After both crank arms have been removed, remove the black protective sleeves from each end of the pedal shaft.

8. Remove the air filter from the carburetor. Loosen the clamp screw (Figure 13) and pull the air filter straight off of the carburetor.
9. Remove the 2 bolts securing the carburetor top. The carburetor top, spring, throttle valve and choke release pawl will stay with the throttle cable (Figure 14).
10. Remove the 2 bolts securing the intake manifold (Figure 15) and remove it along with the carburetor.
11. Remove the nut at the front of the right-hand chain guard (Figure 16), loosen the right rear shock absorber lower bolt (Figure 17) and let the chain guard pivot down. It is not necessary to completely remove it.

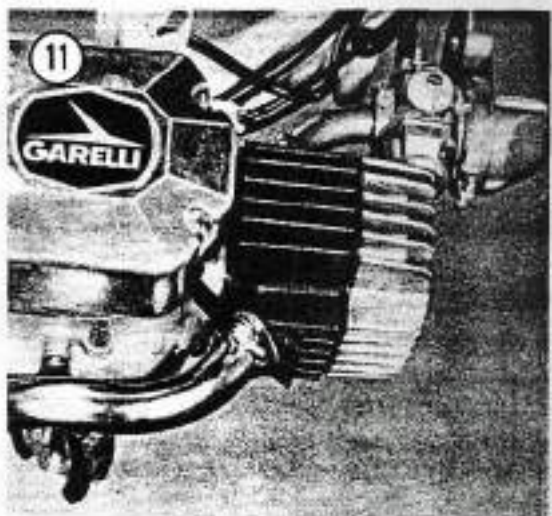
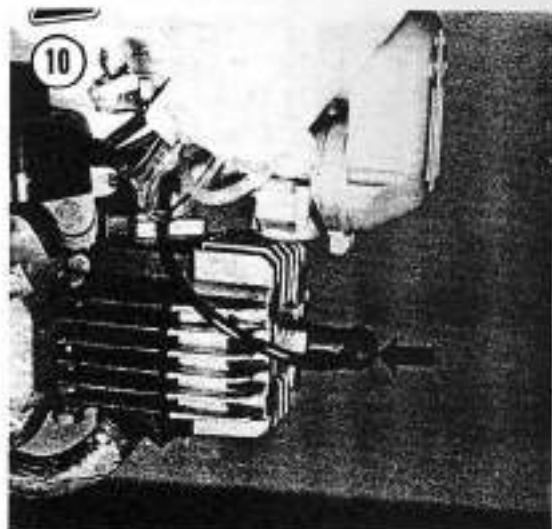
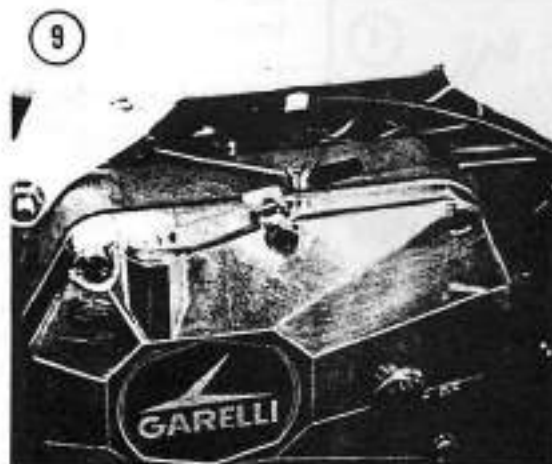

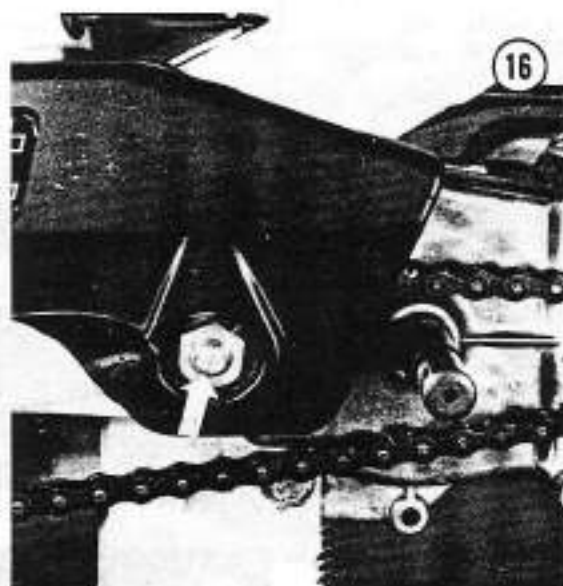
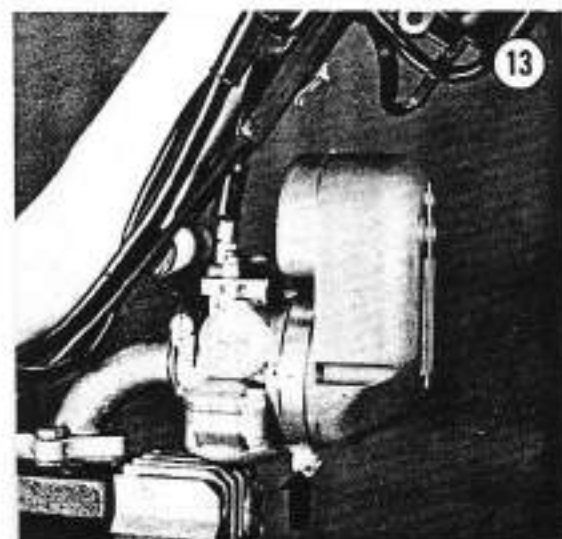
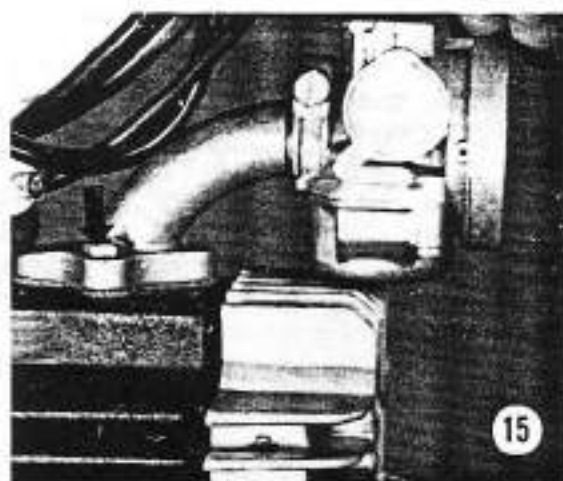
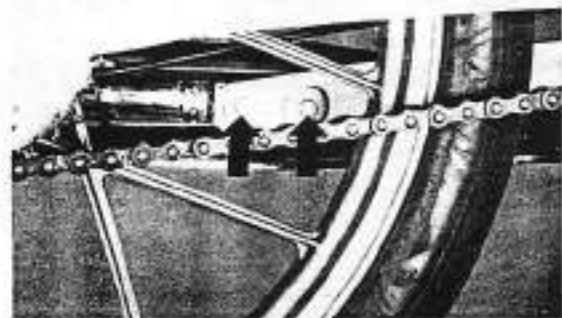

5

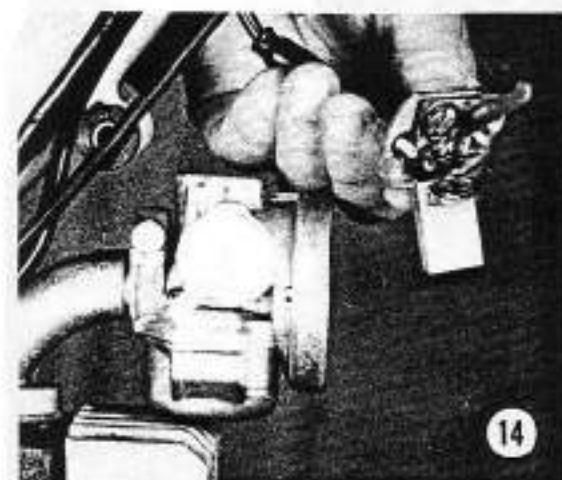

12. Remove the master link on the drive chain (Figure 18) and remove the chain.

13. Remove the magneto as described under *Magneto Removal/Installation* in Chapter Eight.

14. Remove the clutch as described under *Clutch Removal/Installation* in Chapter Six.

15. Remove the 3 bolts securing the engine to the frame (Figure 19). The upper rear bolt has a ground strap that is attached to the engine.

16. Remove the engine by pulling forward and down and take it to the workbench for further disassembly.

17. Install by reversing the removal steps.

NOTE: *Install serrated washer and ground strap onto upper rear bolt prior to installing it (Figure 20).*

18. Remove the fill cap (Figure 21) on the engine/clutch cover, and fill with 13.5 oz. (400cc) SAE 30 *non detergent* oil.

CAUTION
DO NOT use detergent oil.

NOTE: *In order to measure the correct amount of oil, use a plastic baby bottle. These have measured increments in oz. and cc on the side (Figure 22).*

Model — Gran Sport Twin

1. Place the moped on the centerstand.
2. Remove the 2 screws (Figure 23) securing the step plate and remove it.
3. Remove the screw (Figure 23) securing each engine fairing and remove them.
4. Place a drip pan under the clutch housing, remove the drain plug (Figure 24) and completely drain the oil. Let it drain for at least 10 minutes. Install the plug.
5. Remove both crank arms as described under *Crank Arm Removal/Installation*, Chapter Six.
6. Push in on the clutch start arm (Figure 25) and unhook the end of the clutch cable.
7. Remove the spark plug wire and the spark plug (A, Figure 26).
8. Remove the large nut (B) securing the exhaust pipe to the cylinder (Figure 26). Remove

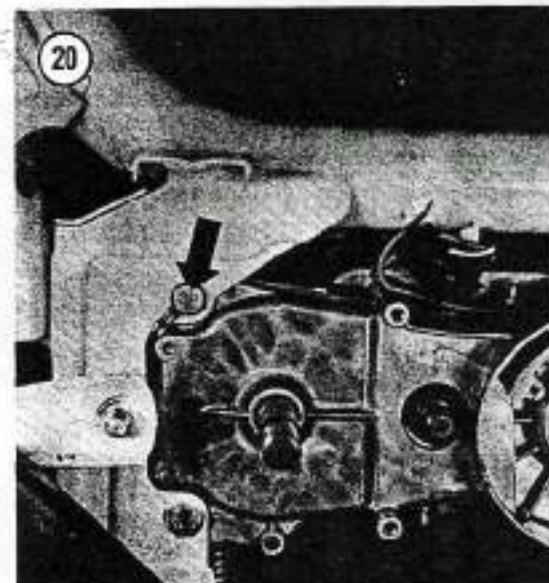
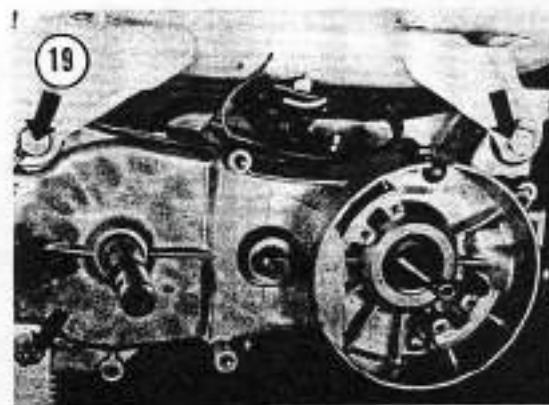
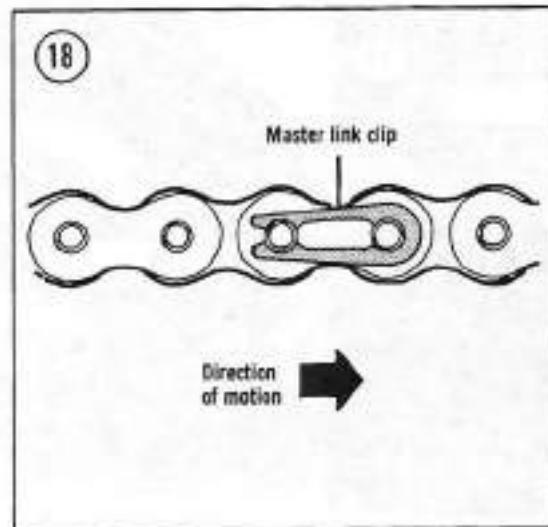

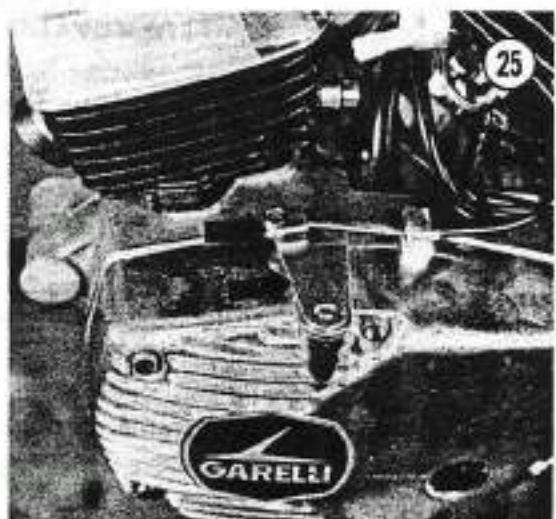
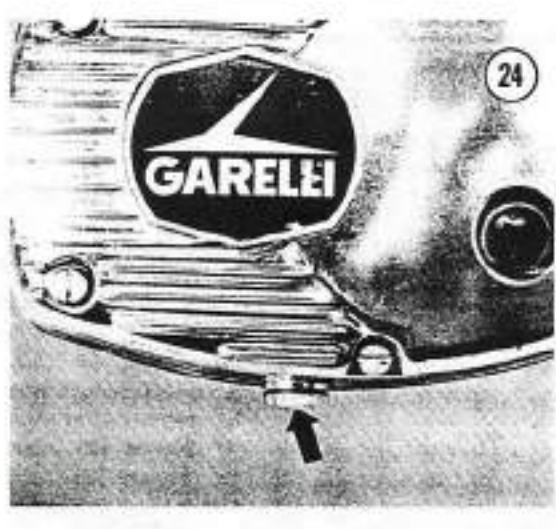
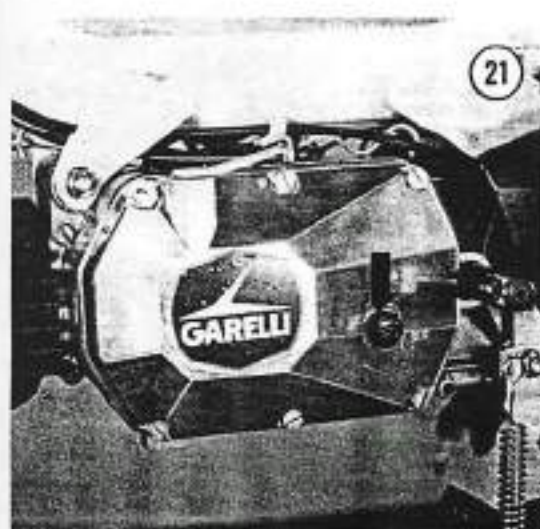

5

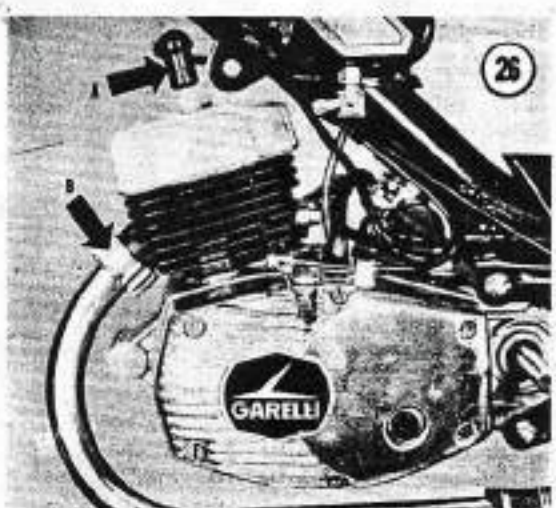

the bolt securing the muffler at the rear (**Figure 27**) and remove the muffler and exhaust pipe.

9. Remove the 3 bolts securing the engine/magneto cover (**Figure 28**) and remove it.

10. Remove the nut, lockwasher, spline washer, sprocket and spline washer (**Figure 29**).

NOTE: To prevent the shaft from rotating while removing the nut have an assistant hold the rear brake on to prevent the rear wheel, chain and sprocket from turning.

11. Turn the fuel shutoff valve to the OFF position and remove the fuel line (**Figure 30**) from the carburetor.

12. Loosen the clamp screw securing the carburetor and air filter to the intake manifold and remove them.

13. Remove the magneto as described under *Magneto Removal/Installation* in Chapter Eight.

14. Remove the upper bolt, washer and nut on the cylinder head and the upper bolt, washer and nut securing the engine to the frame (**Figure 31**).

15. Let the engine pivot down (**Figure 32**) and remove the lower bolt, washer and nut. Remove the engine and take it to the workbench for further disassembly and clutch removal. Remove the clutch as described under *Clutch Removal/Installation* in Chapter Six.

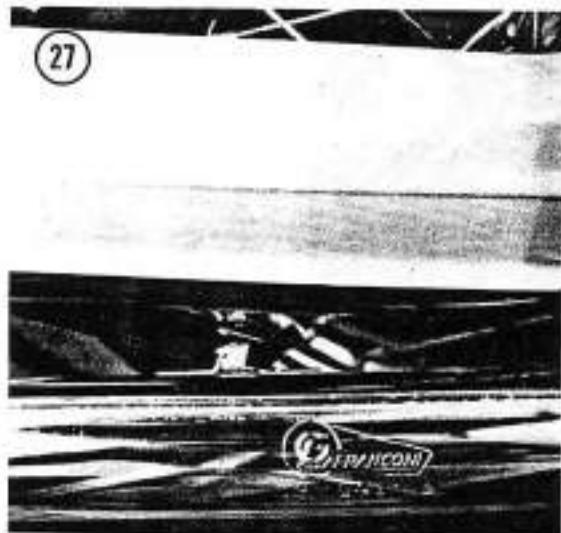

16. Install by reversing the removal steps.

NOTE: Install the ground strap onto the upper rear bolt prior to installing it (**Figure 33**).

17. Remove the fill cap (**Figure 34**) on the engine/clutch cover and fill with 13.5 oz. (400cc) SAE 30 non detergent oil.

CAUTION

DO NOT use detergent oil.

NOTE: In order to measure the correct amount of oil, use a plastic baby bottle (**Figure 22**). These have measured increments in oz. and cc on the side.

CYLINDER HEAD REMOVAL/INSTALLATION

**Model — Eureka, Sport,
Gran Sport, Super Sport XL**

The cylinder head may be removed for service without removing engine from frame.

NOTE: If the cylinder head is to be replaced be sure to order the correct one for your particular model. The 17, 20, 25, and 30 mph versions of the moped have their own specific head configuration.

1. Place the moped on the centerstand.
2. Remove the spark plug wire and spark plug (**Figure 35**).

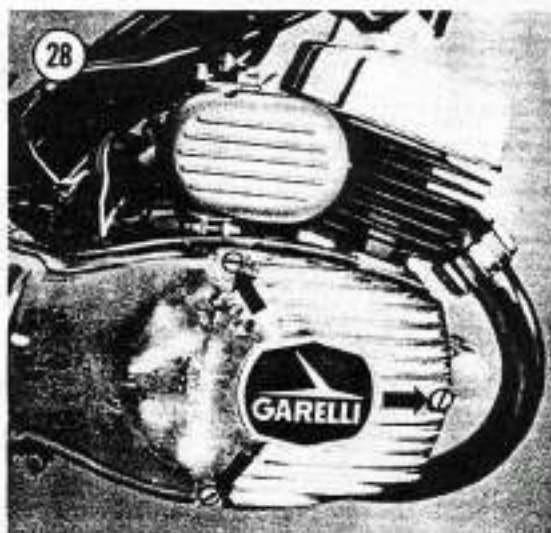

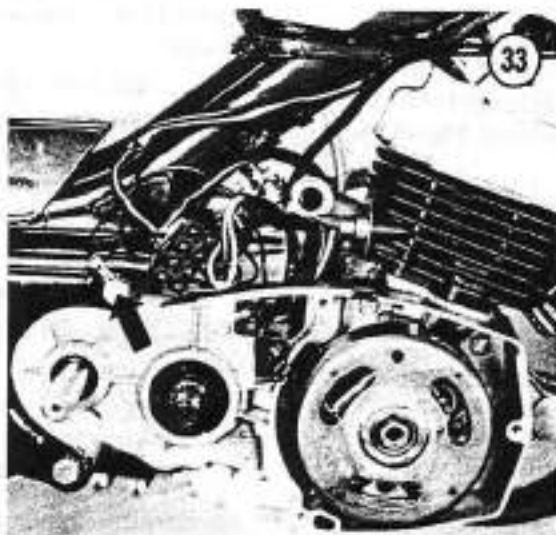
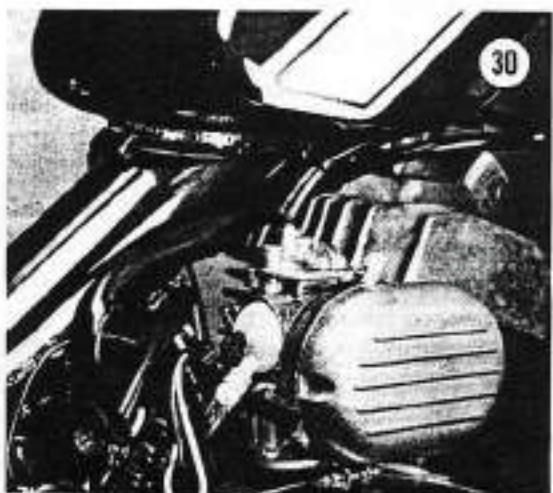
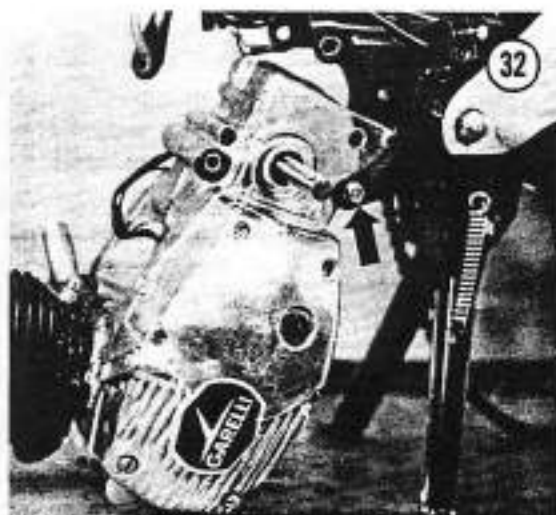
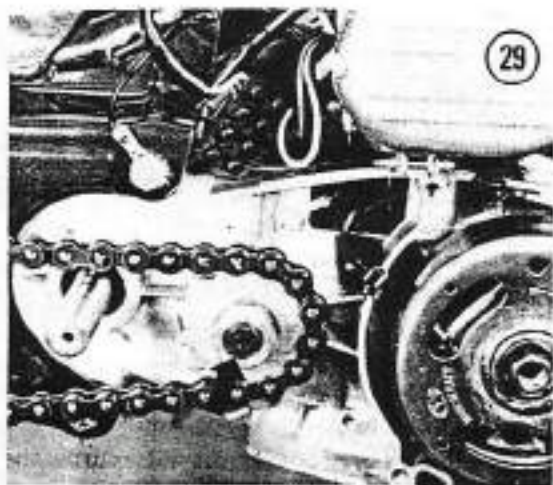

5

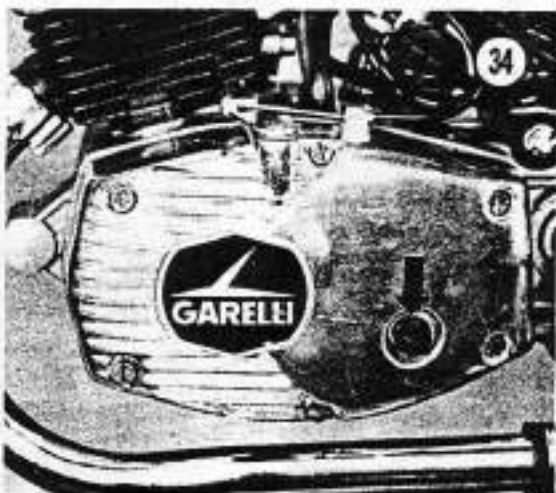

3. Loosen, but do not remove, the 4 nuts securing the cylinder head to the engine.

CAUTION

To prevent warping the head, loosen the 4 nuts in the sequence shown in Figure 36.

After all nuts have been loosened, remove the nuts and washers.

4. Gently wiggle the head and pull it off the cylinder.

5. Remove the cylinder head gasket and discard.

6. Install by reversing the removal steps.

NOTE: Be sure to use a new head gasket.

7. Install the washers with the serrated side up toward the nuts. Finger-tighten all nuts snug and then torque all nuts to 11-14 ft.-lb. (15-18 N•m). Use the sequence shown in Figure 36.

Model — Gran Sport Twin

To remove the cylinder head it is necessary to either completely or partially remove the engine from the frame.

NOTE: If the cylinder head is to be replaced be sure to order the correct one for your particular model. The 17, 20, 25, and 30 mph versions of the moped have their own head configuration.

1. Place the moped on the centerstand.
2. Remove the 2 screws (Figure 37) securing the step plate and remove it.

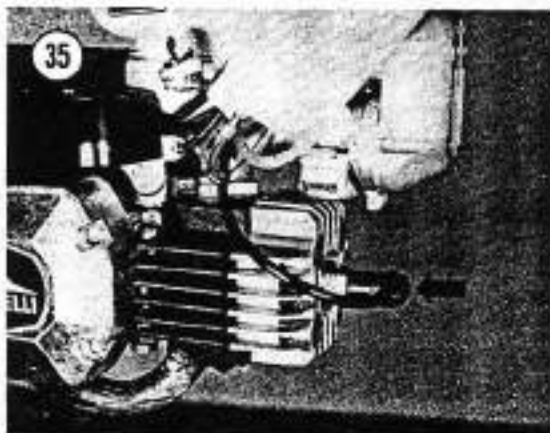

3. Remove the screw (Figure 37) securing each engine fairing and remove them.

4. Remove the right-hand crank arm as described under *Crank Arm Removal/Installation* in Chapter Six.

5. Push in on the clutch start arm (Figure 38) and unhook the end of the clutch cable.

6. Remove the spark plug wire and the spark plug (A, Figure 39).

7. Remove the large nut (B, Figure 39) securing the exhaust pipe to the cylinder. It is not necessary to completely remove the exhaust pipe and muffler; just pivot them down.

8. Remove the 3 screws (Figure 40) securing the engine/magneto cover and remove it.

9. Remove the master link on the drive chain (Figure 41) and remove the chain from the drive sprocket.

10. Turn the fuel shutoff valve to the off position and remove the fuel line (Figure 42) from the carburetor.

11. Loosen the clamp screw securing the carburetor and air filter to the intake manifold and remove them.

12. Remove the *upper rear bolt, washer and nut* (A, Figure 43) securing the engine into the frame.

NOTE: Prior to removal of the front bolt have some blocks of wood handy to place under the crankcase to rest it on.

Remove the upper bolt, washer and nut on the head (B, Figure 43). Let the engine pivot down onto the blocks of wood.

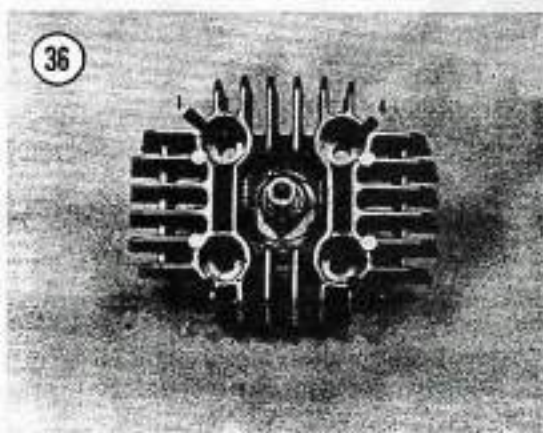

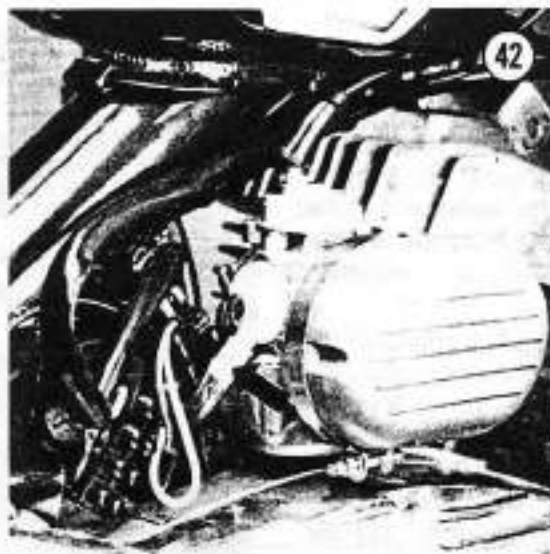
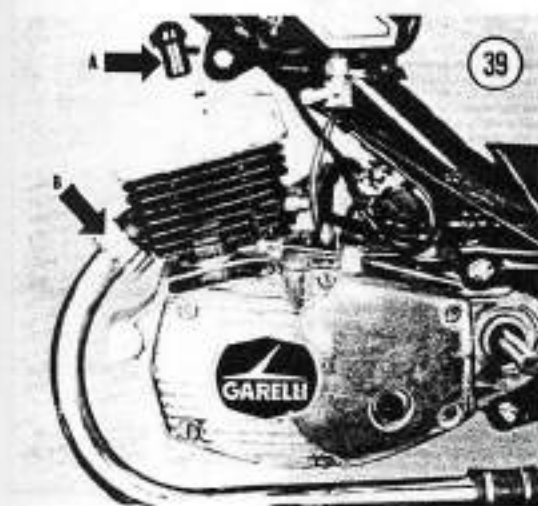
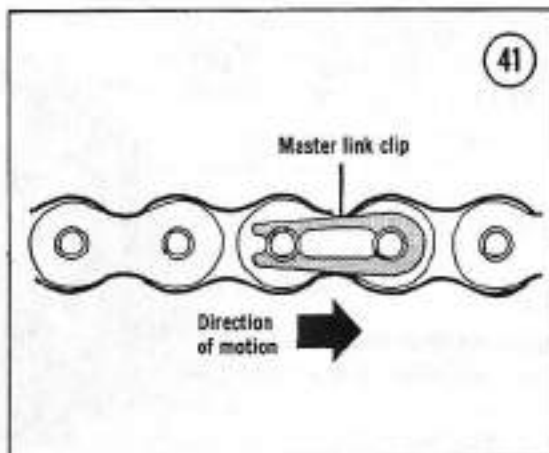
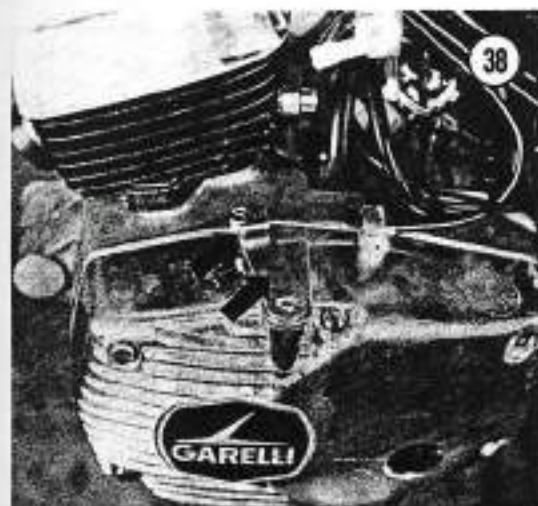
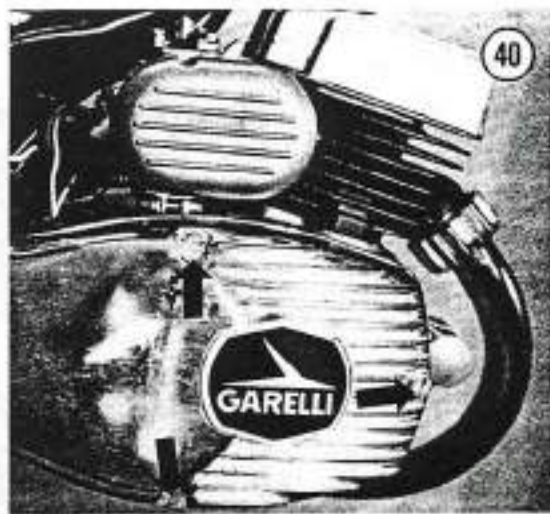
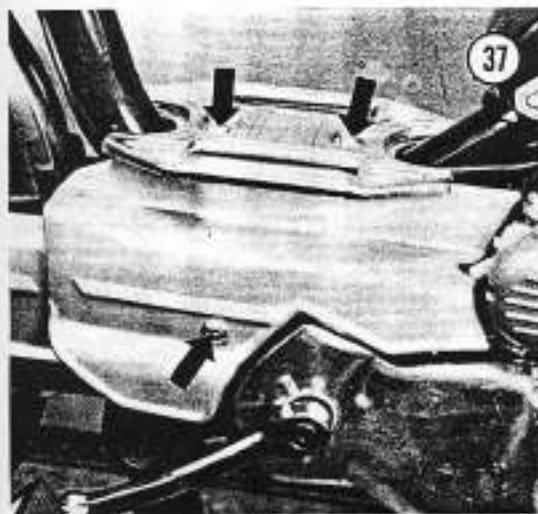

13. Loosen, but do not remove, the 4 nuts securing the cylinder head to the engine.

CAUTION

To prevent warping the head, loosen the 4 nuts in a sequence shown in Figure 44.

After all nuts have been loosened, remove the nut and washers.

14. Gently wiggle the head and pull it off of the cylinder.

15. Remove the cylinder head gasket and discard it.

16. Install by reversing the removal steps.

NOTE: *Be sure to use a new head gasket.*

17. Install the washers with the serrated side *up* toward the nuts. Finger-tighten all nuts snug and then torque all nuts to 11-14 ft.-lb. (15-18 N•m).

CYLINDER

Removal (Eureka, Sport, Gran Sport, Super Sport XL)

The cylinder can be removed for service without removing the engine assembly from frame.

1. Remove cylinder head as described under *Cylinder Head Removal/Installation* in this chapter.

2. Unscrew the 2 Allen head bolts securing the exhaust pipe to the cylinder (**Figure 45**). Just let it down; there is no need to remove it.

3. Remove the 2 bolts securing the intake manifold to the cylinder (**Figure 46**). Remove the intake manifold and the carburetor from the cylinder. They can hang from the throttle cable — it is not necessary to completely remove them.

4. Remove the cylinder from the crankcase. If it is stuck, rotate the crank pedal to position the piston to the bottom of its stroke. Gently tap on the exhaust port with a rubber or plastic mallet. If engine assembly has been removed from the frame, place cylinder and crankcase assembly upside down on the crankcase studs. Tap the exhaust port with a rubber or plastic mallet.

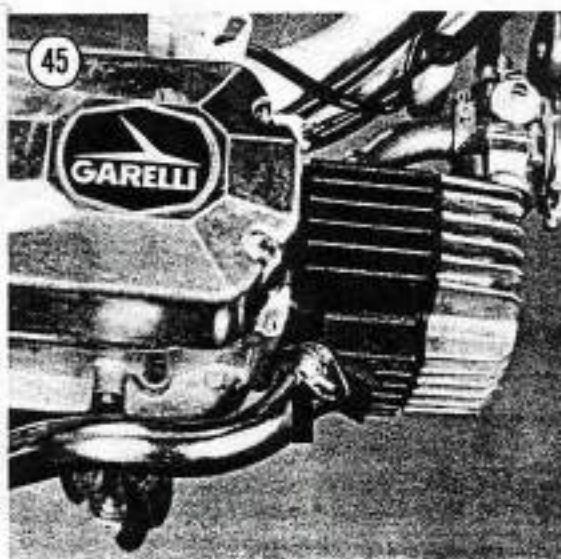
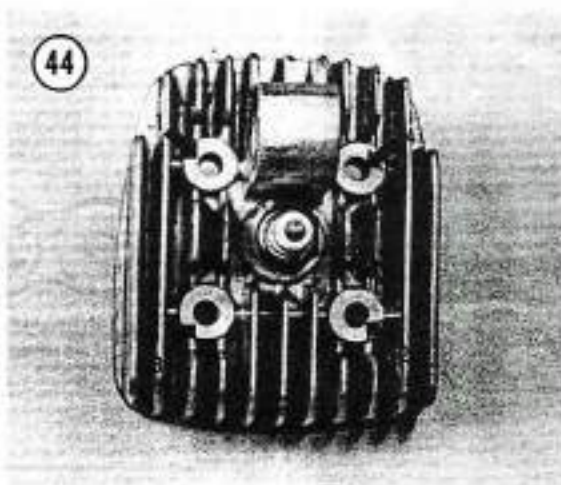
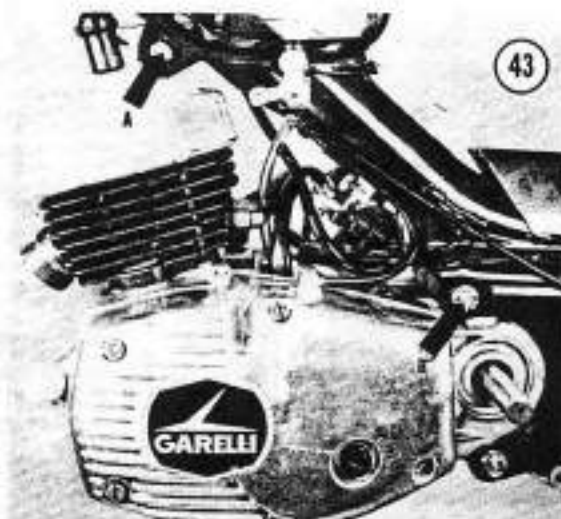

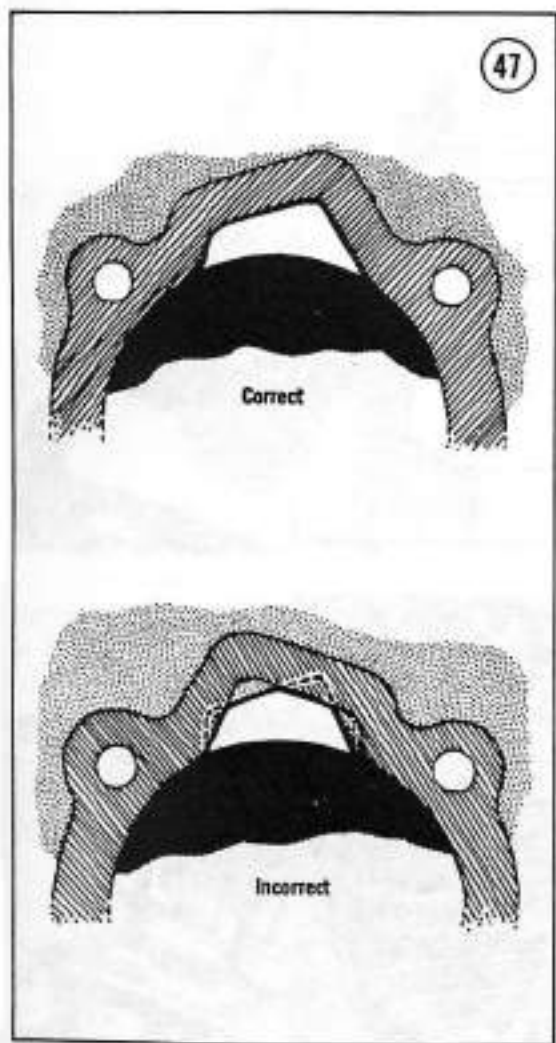
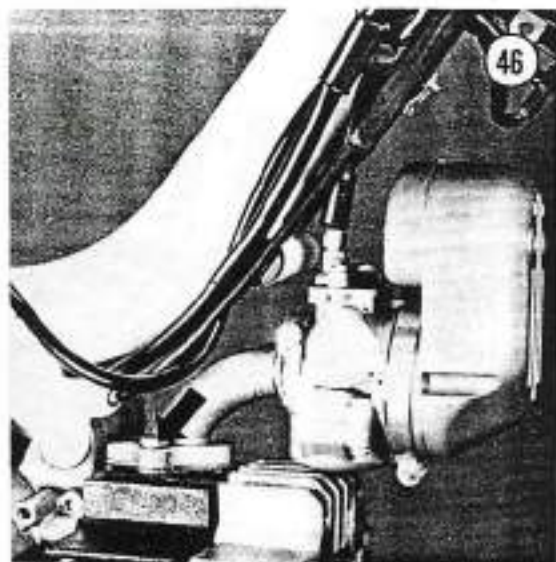

CAUTION

Do not tap on the cooling fins as they are fragile and may be damaged.

5. Pull the cylinder straight off of the crankcase studs.
6. Remove the cylinder base gasket and discard. Place clean rags into the crankcase opening to prevent the entry of small parts and foreign matter.

Installation (Eureka, Sport, Gran Sport, Super Sport XL)

1. Clean off the surfaces of the base of the cylinder and the top of the crankcase prior to installing the new base gasket.
2. Apply gasket cement to only one side of gasket and place onto the crankcase. Make sure the gasket aligns properly with the transfer ports (Figure 47), if this is positioned incorrectly, it will reduce power.

NOTE: *To make cylinder installation easier, use a wood block holding fixture (Figure 48) to hold the piston in position. Slide the fixture between the crankcase studs with the connecting rod fitting into the slot (Figure 49).*

3. Make sure the piston ring gap aligns with the stop in the piston ring groove (Figure 50).
4. Push the cylinder down over the piston by hand only (Figure 51), do not use a hammer or mallet. Compress each ring as it enters the cylinder. Also make sure the exhaust port is facing down.

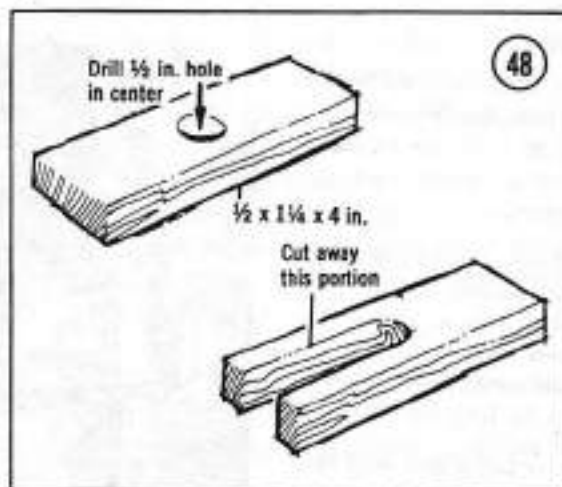

5. Remove the wood holding fixture and push the cylinder down until it bottoms.
6. Install the 2 bolts securing the exhaust pipe to the cylinder.
7. Install the 2 bolts securing the intake manifold and carburetor to the cylinder.
8. Install the cylinder head as described under *Cylinder Head Removal/Installation* in this chapter.

Removal (Gran Sport Twin)

1. Remove the cylinder head as described under *Cylinder Head Removal/Installation* in this chapter.
2. Remove the cylinder from the crankcase. If it is stuck, rotate the left-hand crank pedal to position the piston to the bottom of its stroke. Gently tap the exhaust port (Figure 52) with a rubber or plastic mallet.

CAUTION

Do not tap on the cooling fins as they are fragile and may be damaged.

3. Pull the cylinder straight off of the crankcase studs.
4. Remove the cylinder base gasket and discard it. Place a clean rag into the crankcase opening to prevent the entry of small parts and foreign matter.

Installation (Gran Sport Twin)

1. Clean off the surfaces on the base of the cylinder and the top of the crankcase prior to installing the new base gasket.
2. Apply gasket cement to only one side of the gasket and place onto crankcase (Figure 53). Make sure the gasket aligns with the transfer ports (Figure 47); if this is positioned incorrectly, it will reduce power.

NOTE: To make cylinder installation easier, use a wood block holding fixture (Figure 48) to hold the piston in position. Slide the fixture between the crankcase studs with the connecting rod fitting into the slot.

3. Make sure the piston ring gap aligns with the stop in the piston ring groove (Figure 50).

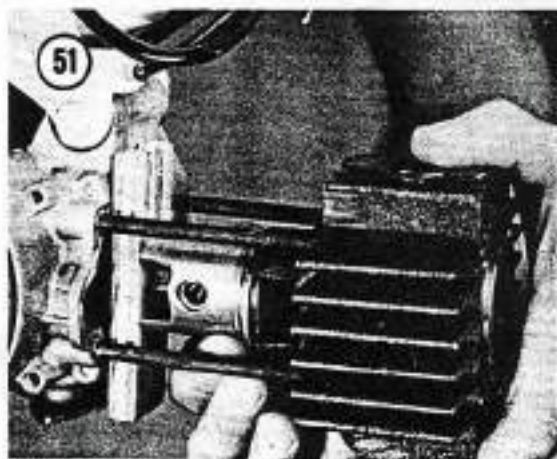
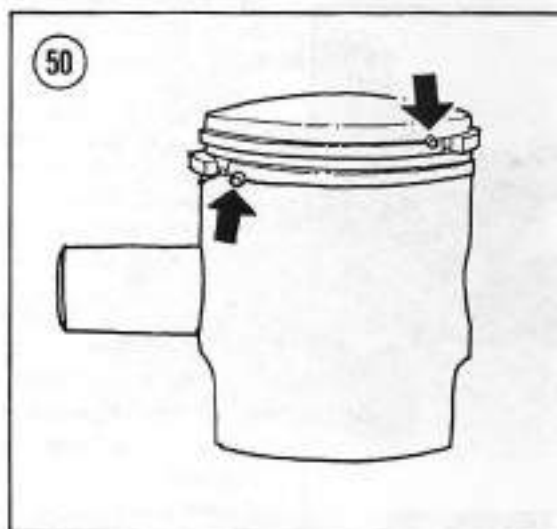
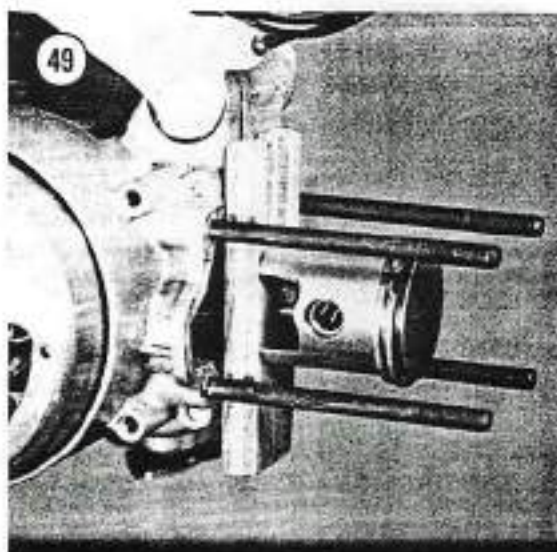

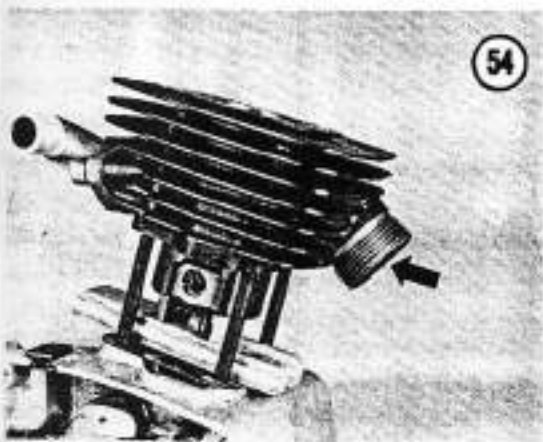
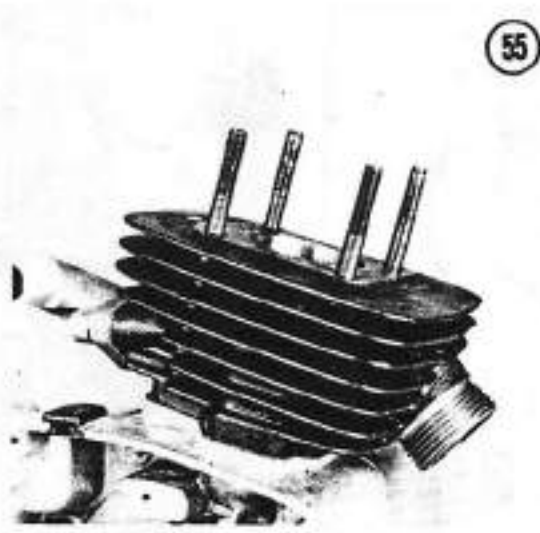
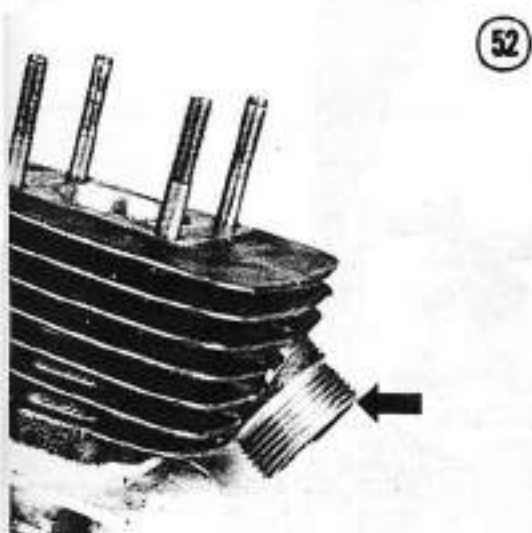

4. Push the cylinder down over the piston by hand only. Do not use a hammer or mallet. Compress each ring as it enters the cylinder. Also make sure the exhaust port is *facing forward* (Figure 54).

5. Remove the wood holding fixture and push the cylinder down until it bottoms (Figure 55).

6. Install the cylinder head as described under *Cylinder Head Removal/Installation* in this chapter.

5

PISTON AND WRIST PIN

Removal/Installation

Prior to removal of wrist pin, hold the rod tightly and rock the piston as shown in Figure 56. Any rocking movement (do not confuse with a sliding motion which is normal) indicates wear to the wrist pin, rod bearing, wrist pin bore or, more likely, a combination of all three.

1. Remove the 2 wrist pin snap rings (Figure 57) with needle nose pliers.

2. Push out the wrist pin with a small socket or dowel. If pin is difficult to push out, use the homemade tool as shown in Figure 58. If wrist pin is to be reused, it should be marked so it will be reinstalled in the same position.

3. Push out the needle bearing race from the connecting rod, clean and inspect it. If it is OK, thoroughly oil with light weight oil and fit it back into the connecting rod. If the condition is doubtful, replace it.

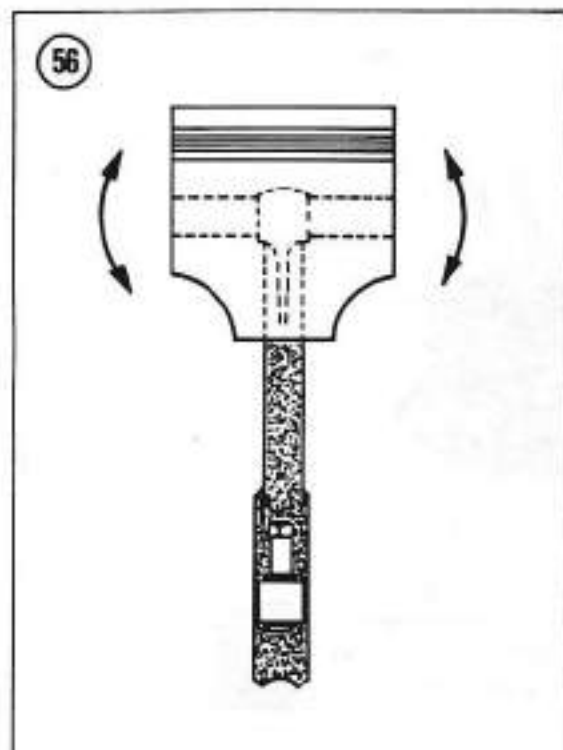

4. Install by reversing the removal steps; make sure the letter "S" (Figure 59) on top of the piston is toward the exhaust port when repositioning it on the connecting rod.

NOTE: Install wrist pin with the same tool used for removal (Figure 58). Eliminate the piece of pipe.

5. Carefully align the piston to the connecting rod when installing the wrist pin to avoid damage to the needle bearings. Install the wrist pin; refer to the mark made in Step 2 if reusing the old wrist pin.

6. As the wrist pin is being pushed back into the piston and connecting rod bearing, observe its travel from underneath the piston to prevent any binding.

NOTE: Make sure the snap rings are seated correctly in the piston.

7. After installing the wrist pin, check the surface of the piston where the installation tool came in contact with it. If there are any scuff marks, clean them off with a fine cut file. File as little as possible being careful not to remove too much metal.

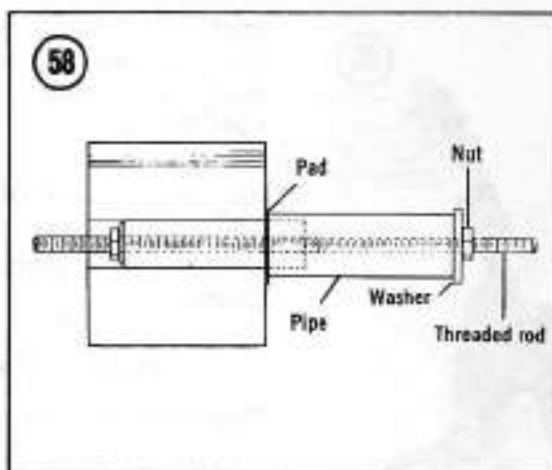
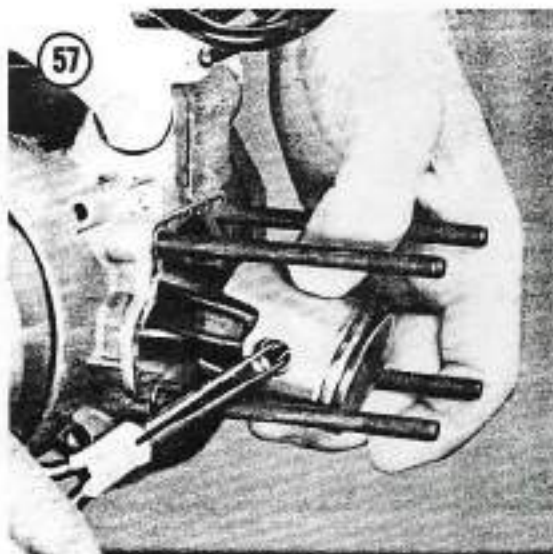

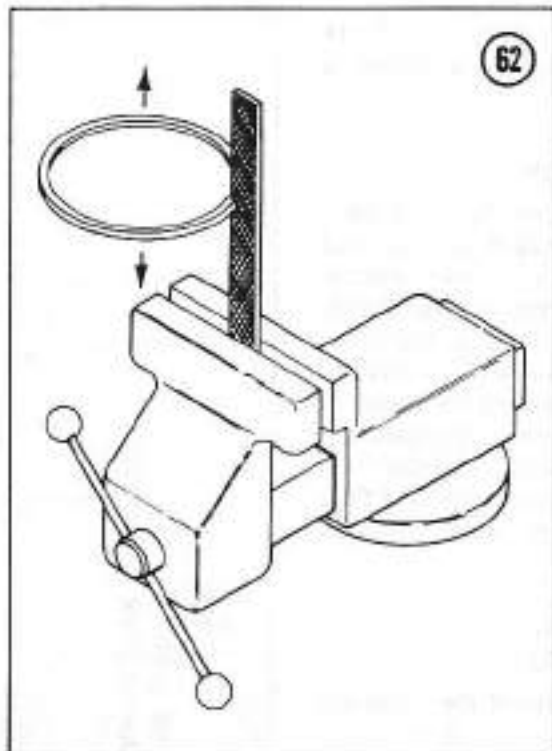
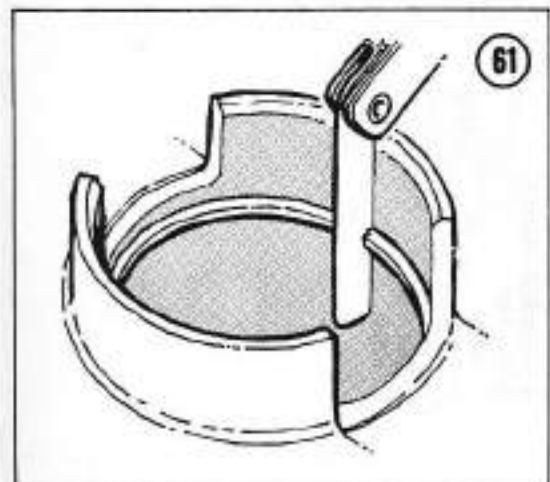
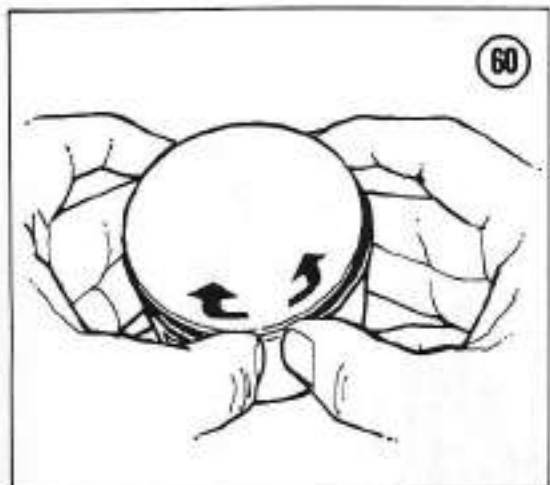

Piston Cleaning and Inspection

1. Scrape all carbon from the top of piston with a dull screwdriver. Be careful not to scratch the surface.
2. Clean out the grooves with a broken ring or small sharp screwdriver.
3. Clean out the wrist pin snap ring grooves.
4. Inspect the piston top and skirt for cracks or damage; replace if necessary.

PISTON RING REPLACEMENT

Piston rings can be replaced without removing the piston from the connecting rod.

1. Remove top ring first by spreading each end with your thumbs, just enough to slide it up and over the piston (**Figure 60**).

2. Repeat the same procedure for the second ring.

3. Clean out all carbon deposits from ring grooves. Inspect groove for burrs, nicks or broken and cracked surfaces.

4. Check the gap of each ring by inserting the ring into the bottom of the cylinder bore about $\frac{1}{8}$ in. and squaring it to the wall by tapping it with the piston. Insert feeler gauge as shown in **Figure 61**. The gap should be between 0.021-0.039 in. (0.3-1.0mm). If the gap is smaller than specified, hold a small file in a vise, grip the ends of the ring with your fingers and move ring up and down on the file slowly to enlarge the gap (**Figure 62**). *Do a little at a time to avoid removing too much and ruining the ring.*

5. Prior to installation in the piston, roll each ring around its groove as shown in **Figure 63** to check for binding. Minor binding may be cleaned up with a fine cut file.

6. Spread the rings carefully with your thumbs—just enough to slip them down and over the piston (**Figure 60**).

NOTE: Install the lower ring first and then the top.

7. Align the end gaps of the rings with the locating pins in each ring groove as shown in **Figure 64**.

CRANKCASE

In order to gain access to the crankshaft, connecting rod, and crankshaft bearings and seals, it is necessary to split the crankcase halves. This procedure requires considerable care as the parts are easily damaged. If you feel not qualified to accomplish it, considerable money can be saved by removing the engine as described under *Engine Removal/Installation* in this chapter. Take the crankcase assembly to your moped dealer or motorcycle machine shop and have them perform any operation necessary.

Disassembly (Eureka, Sport, Gran Sport, Super Sport XL)

Figure 65 shows all parts of the crankcase and the engine covers.

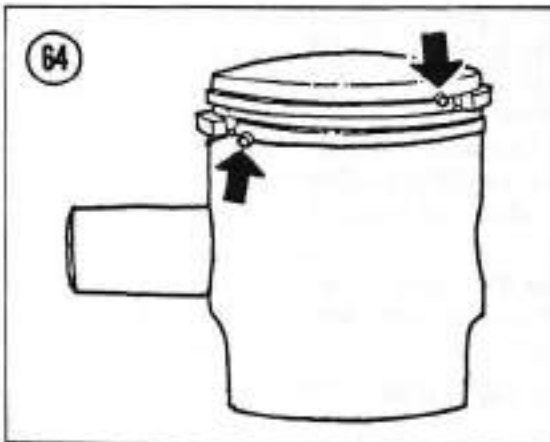
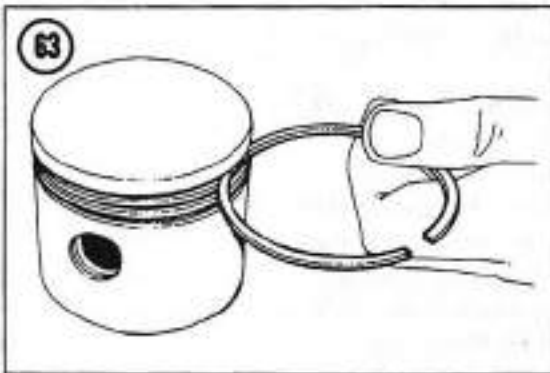

CRANKCASE AND ENGINE COVERS (EUREKA, SPORT, GRAN SPORT, AND SUPER SPORT XL)

- | | | |
|------------------------------------|----------------------------|--------------------------------------|
| 1. Crankcase half — left-hand side | 10. Screw (14) | 19. Screw (4) |
| 2. Breather | 11. Decal — left-hand side | 20. Bushing (6) |
| 3. Nut — cylinder head (4) | 12. Engine/clutch cover | 21. Spacer (5) |
| 4. Washer — cylinder head (4) | 13. Oil fill cap | 22. Gasket |
| 5. Crankcase stud (4) | 14. Gasket | 23. Bearing (4) |
| 6. Seal — crankshaft (2) | 15. Screw (2) | 24. Seal — primary shaft |
| 7. Grommet — magneto wires | 16. Brain plug | 25. Dowel pin (2) |
| 8. Decal — right-hand side | 17. Gasket | 26. Crankcase half — right-hand side |
| 9. Engine cover | 18. Gasket | |

65

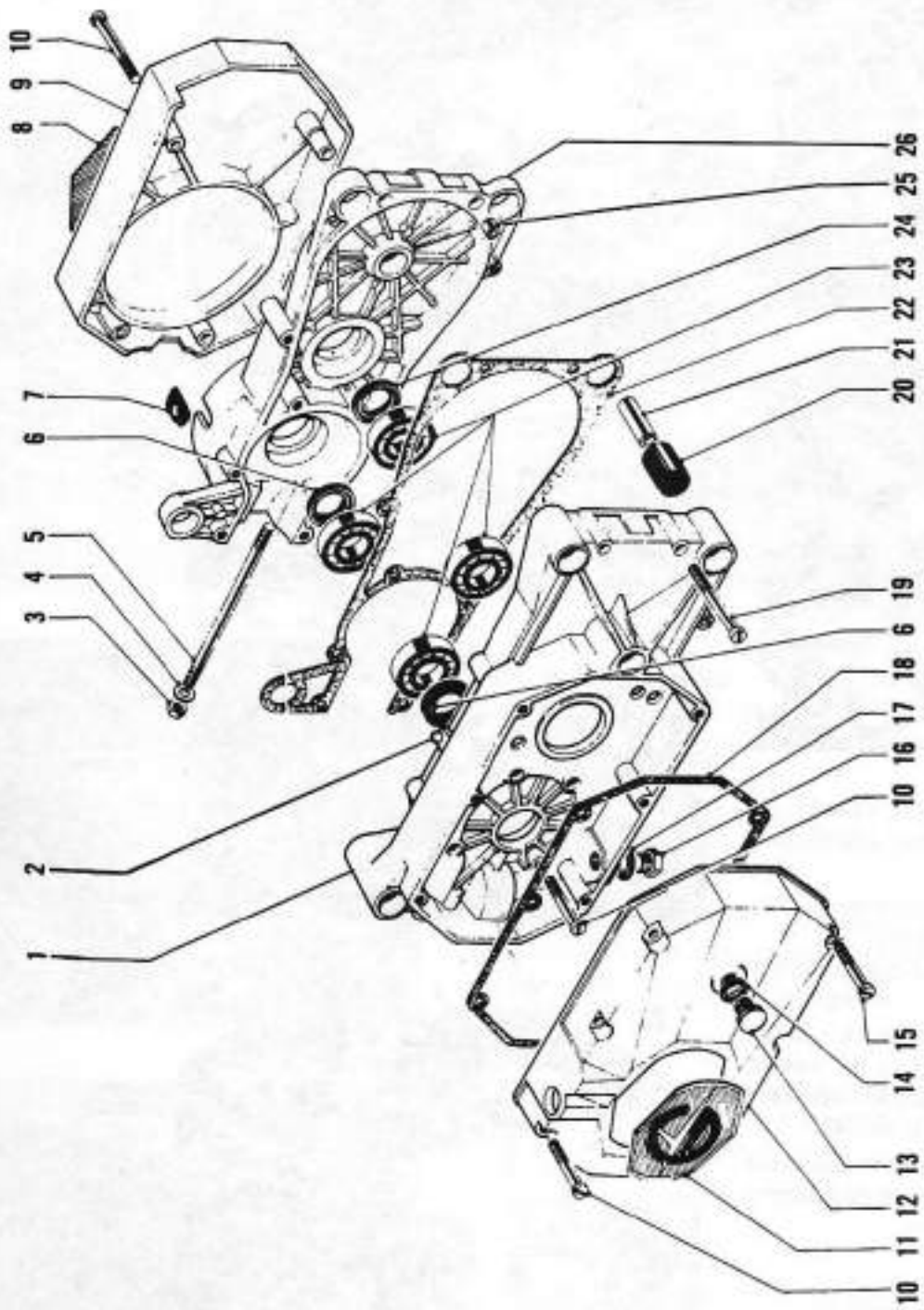

5

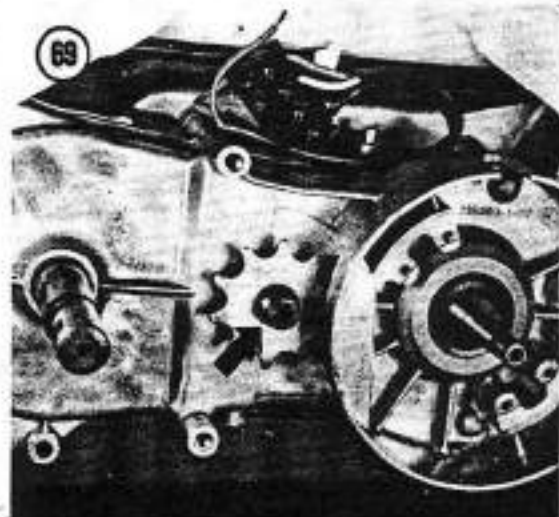
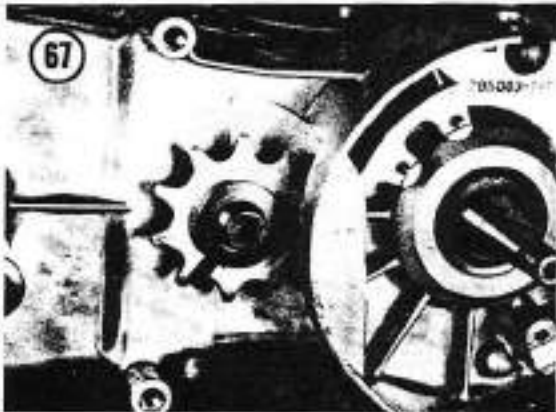
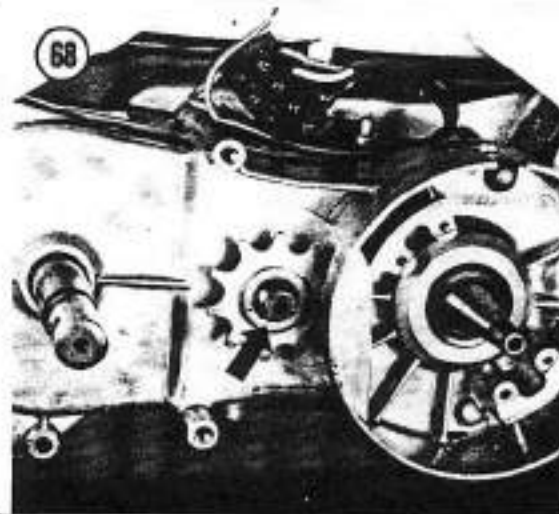
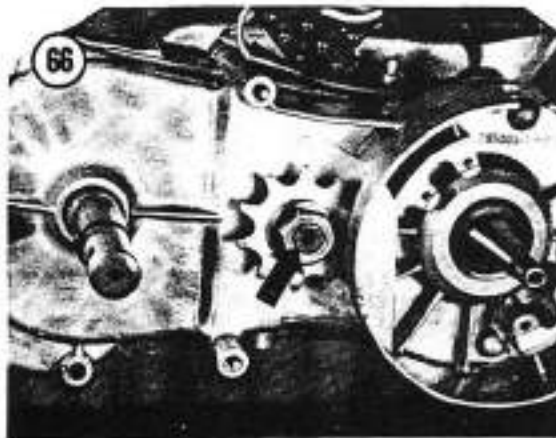

1. Remove the cylinder head and cylinder as described under *Cylinder Removal/Installation* in this chapter.

2. Remove the piston as described under *Piston Removal/Installation* in this chapter.

3. Remove the engine as described under *Engine Removal/Installation* in this chapter.

4. Remove the nut securing the sprocket to the primary shaft (Figure 66). Remove the washer (Figure 67), spline washer (Figure 68), sprocket (Figure 69) and spline washer (Figure 70).

5. Remove the 10 screws securing the crankcase halves together (Figure 71). The outer 4 screws are longer than the inner 6 screws.

CAUTION

To prevent warping the crankcase halves, loosen the 10 screws in a sequence shown in Figure 71.

After all screws have been loosened remove them.

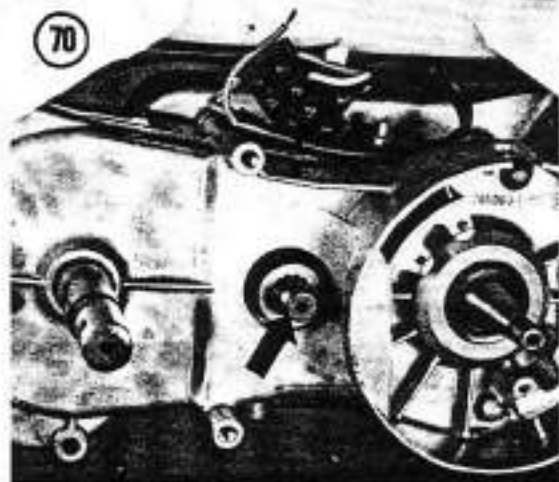

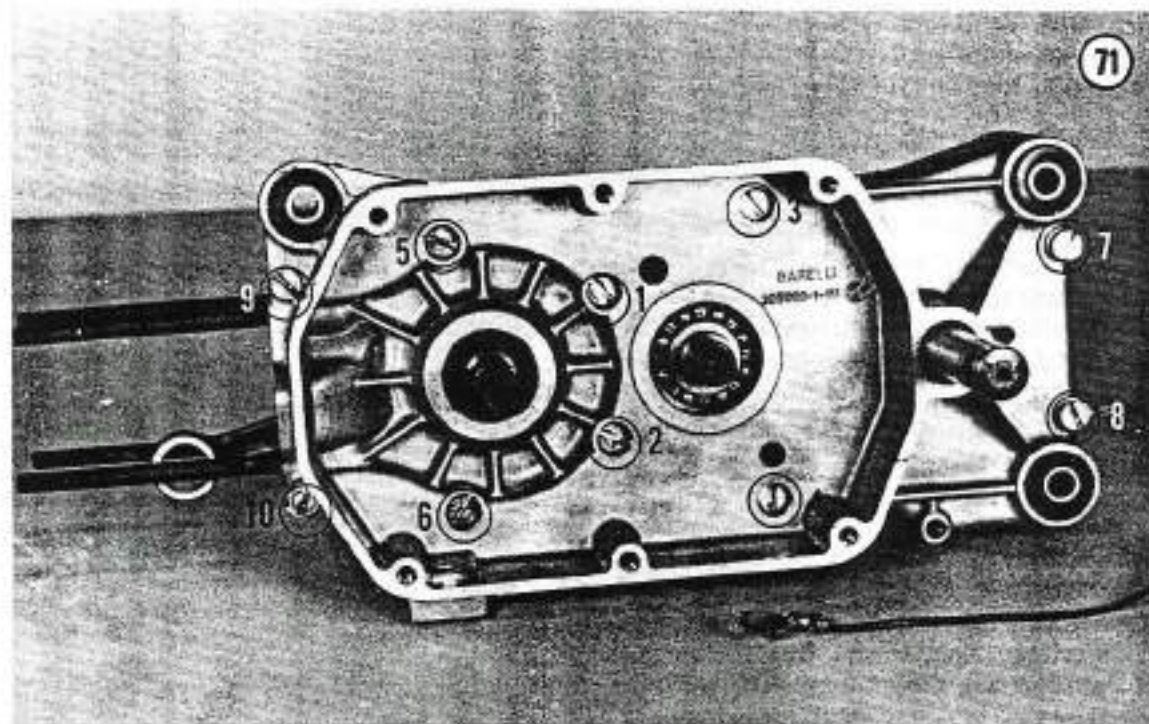

5

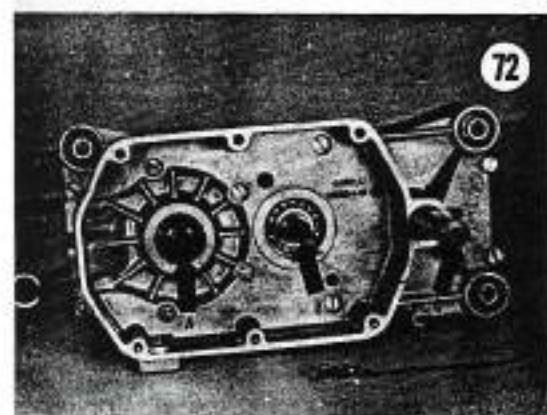

6. On the left-hand side crankcase, tap on the ends of the crankshaft (A, Figure 72) the primary shaft (B) and the pedal shaft (C) alternately with a plastic mallet until the 2 crankcase halves separate.

CAUTION

Never use a metal hammer as the crankcase will be damaged.

7. Slide out, or tap out with a plastic mallet, the crankshaft and connecting rod (A), and the primary shaft (B) and the pedal shaft (C). See Figure 73.

CAUTION

The primary shaft (B) and the pedal shaft (C) have to slide out together as they are connected by the chain.

8. Remove the bearings and seals from the crankcase halves.

Assembly (Eureka, Sport, Gran Sport, Super Sport XL)

NOTE: *In order to prevent damage to the oil seals apply a light coat of grease to the feather edge of the seals and to the shafts.*

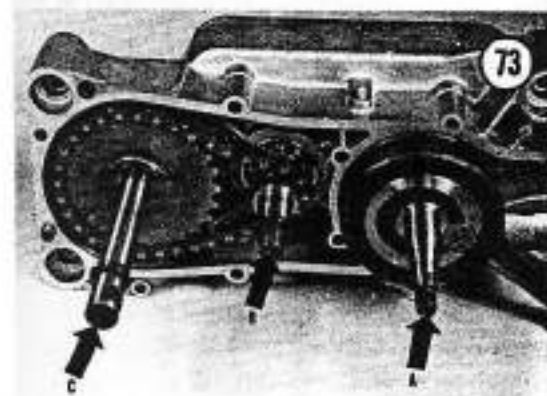

1. Install the crankshaft into the left-hand crankcase (Figure 74). The tapered end of the crankshaft goes into the right-hand crankcase.

CAUTION

To avoid damage to the oil seal when installing the crankshaft, wrap a piece of transparent Scotch tape over the shoulder on the crankshaft prior to installation (Figure 75). Remove all of the tape after installation.

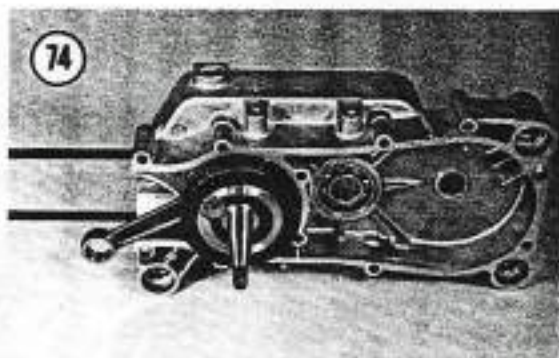

2. Install the clutch coupling (A), return spring (B) and sprocket (C) onto the long end of the pedal shaft (Figure 76).

NOTE: The long end of the pedal shaft and the tapered end of the primary shaft insert into the left-hand crankcase half.

3. Wrap the chain around the sprocket on the pedal shaft and the primary shaft and install them into the left-hand crankcase half.

NOTE: Make sure that the end of the return spring goes in, and stays in, between the 2 ribs in the lower left-hand

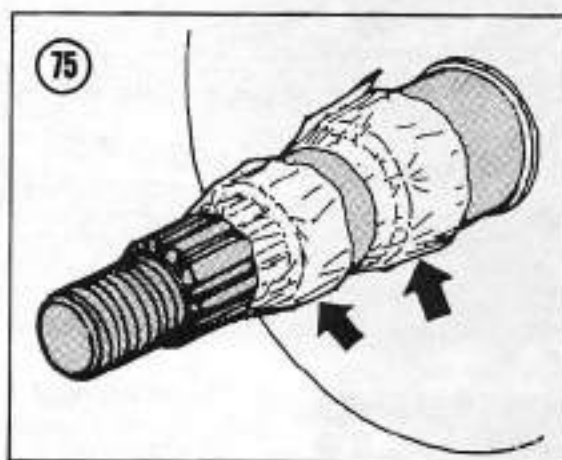

76

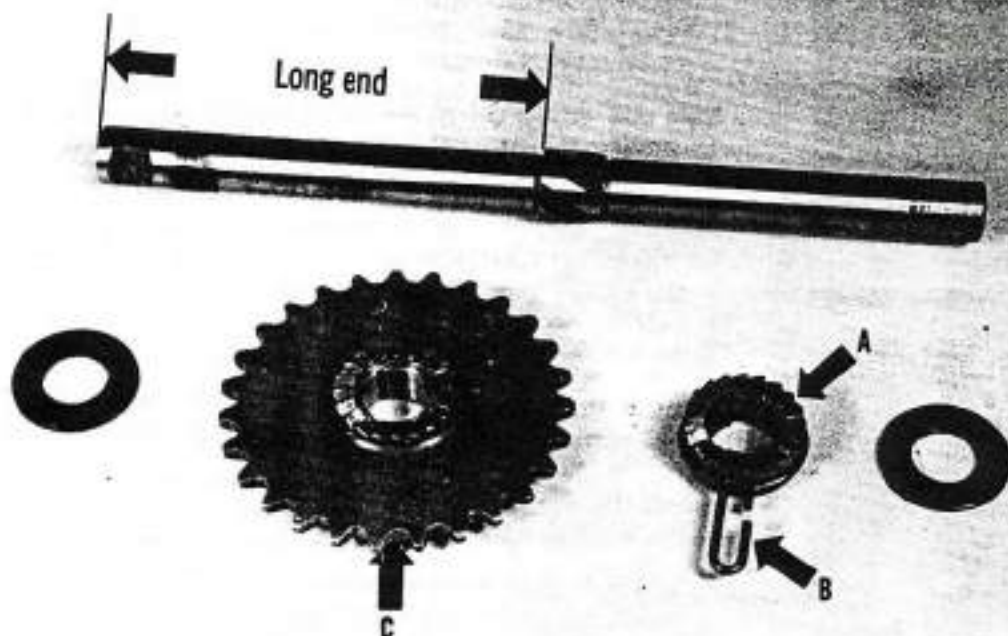

engine/clutch cover (Figure 77). Figure 77 is shown without the pedal shaft in place for clarity.

Tap on the ends of both shafts, with a plastic mallet, to make sure both are seated correctly (Figure 78).

4. Make sure that the 2 dowel pins are in place on the crankcase (Figure 78).
5. Install the washer on the pedal shaft (Figure 79).
6. Apply gasket cement to one side of the new crankcase gasket and apply this side to the crankcase side with the dowel pins.
7. Install the right-hand crankcase half, pressing the 2 halves together, then lightly tap them together with a plastic mallet.
8. Install the 6 short screws into the inner holes and the 4 longer screws into the outer holes in the left-hand crankcase.

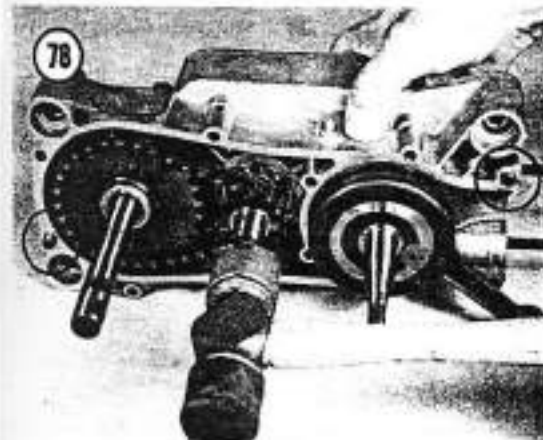
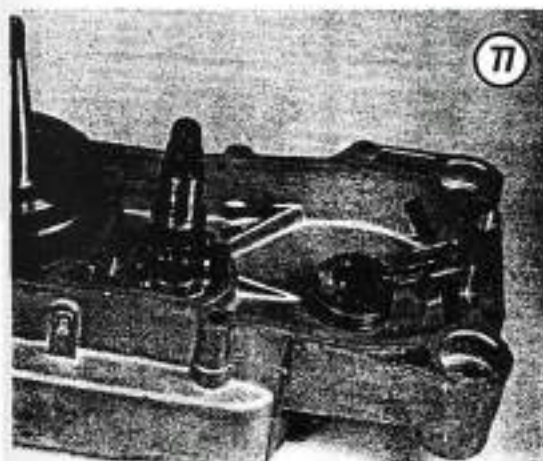

NOTE: Slowly tighten the screws using the sequence indicated in Figure 71.

NOTE: Attach the ground strap to the lower rear bolt (Figure 80).

9. Check that the 3 shafts rotate freely. If they do not, tap on each end of each shaft with a plastic mallet; this should free them.
10. Install the spline washer (Figure 70), sprocket (Figure 69), spline washer (Figure 68), washer (Figure 67) and nut (Figure 66) onto the primary shaft.
11. Install the black plastic sleeves onto each end of the pedal shaft.

Disassembly (Gran Sport Twin)

Figure 81 shows all parts of the crankcase and engine covers.

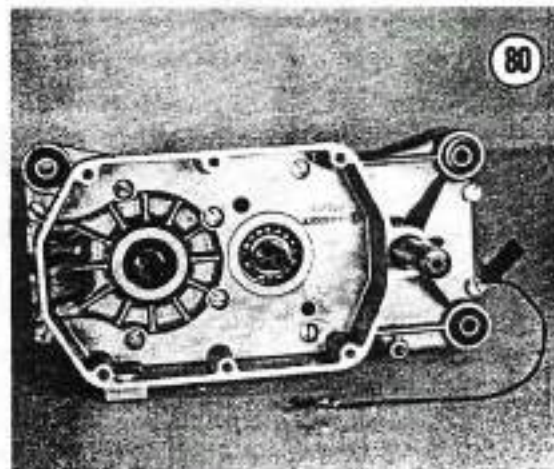
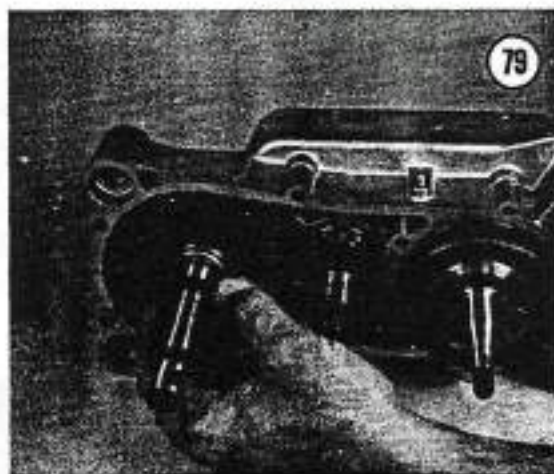

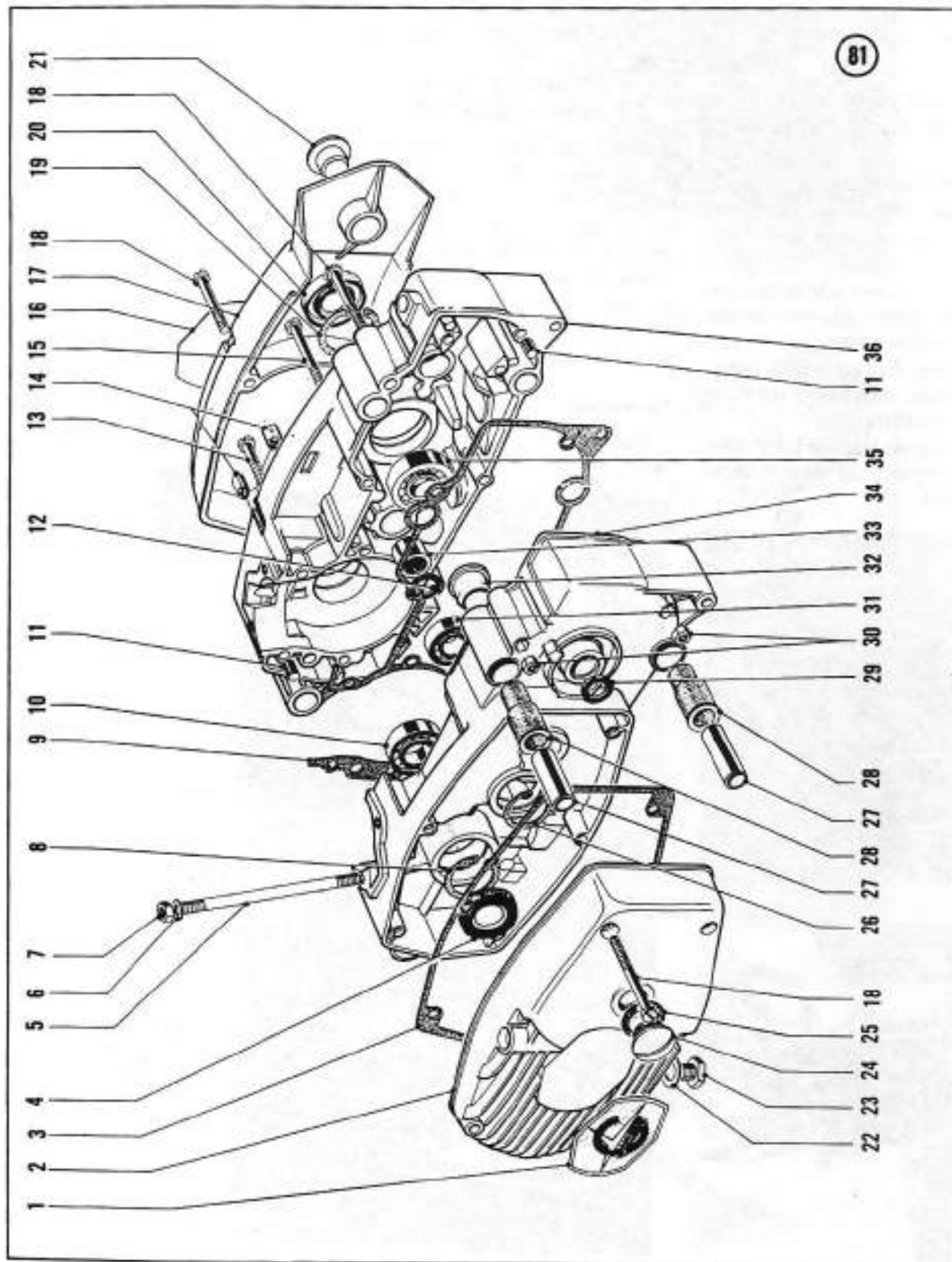

CRANKCASE AND ENGINE COVERS — GRAN SPORT TWIN

- | | | | |
|-------------------------------|-----------------------------|----------------------------|--------------------------------------|
| 1. Decal — left-hand side | 10. Bearing (2) | 19. Circlip | 28. Bushing (2) |
| 2. Engine/clutch cover | 11. Dowel pin (2) | 20. Seal — secondary shaft | 29. Ring seal |
| 3. Gasket | 12. Washer | 21. Grommet | 30. Nut (2) |
| 4. Seal — crankshaft | 13. Screw (6) | 22. Gasket | 31. Bearing — main shaft |
| 5. Crankcase stud (4) | 14. Grommet | 23. Drain plug | 32. Grommet |
| 6. Washer — cylinder head (4) | 15. Screw (1) | 24. Fill cap | 33. Bearing — main shaft |
| 7. Nut — cylinder head (4) | 16. Decal — right-hand side | 25. Gasket | 34. Crankcase half — left-hand side |
| 8. Circlip | 17. Engine cover | 26. Circlip | 35. Bearing |
| 9. Gasket | 18. Screw (3) | 27. Spacer (2) | 36. Crankcase half — right-hand side |

1. Remove the engine as described under *Engine Removal/Installation* in this chapter.
2. Remove the cylinder as described under *Cylinder Removal/Installation* in this chapter.
3. Remove the piston as described under *Piston Removal/Installation* in this chapter.
4. Remove the 10 screws securing the crankcase halves together (Figure 82). The front 6 screws are short, the one with the ground strap is long and the other 3 are medium in length. The 2 rear screws are secured with nuts on the left-hand side.

CAUTION

To prevent warping the crankcase halves, loosen the 10 screws in a sequence shown in Figure 82.

After all screws have been loosened, remove them.

5. On the left-hand side crankcase, tap on the ends of the crankshaft (A, Figure 83) the primary shaft (B) and the pedal shaft (C) alternately with a plastic mallet until the 2 crankcase halves separate.
6. Slide out, or tap out with a plastic mallet, the crankshaft and connecting rod (A), and the primary shaft (B) and the pedal shaft (C). Refer to Figure 84.

CAUTION

The primary shaft (B) and the pedal shaft (C) have to slide out together as they are connected by the chain.

7. The crankcase halves are now ready for the removal of the bearings and seals.

Assembly (Gran Sport Twin)

Assemble parts into the *right-hand crankcase half*.

NOTE: In order to prevent damage to the oil seals apply a light coat of grease to the feather edges of the seals and to the shafts.

1. Install the clutch coupling (A), return spring (B) and the sprocket onto the pedal shaft. Wrap the chain around the sprocket on the pedal shaft and the primary shaft (Figure 85). Install

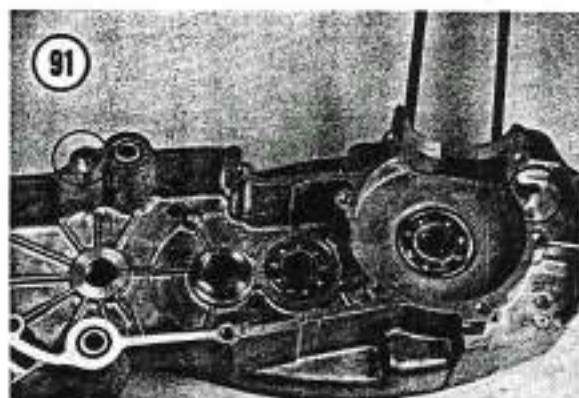

6. Install the right-hand crankcase half, pressing the 2 halves together (Figure 93) then lightly tap them together with a plastic mallet.

7. Install the 6 short screws (S) into the inner holes, the 3 medium screws (M) and the one long screw (L). See Figure 94. The long screw has a ground strap attached to it. The 2 rear medium screws are used in conjunction with nuts installed into the left-hand side. Hold them securely while tightening the screws.

NOTE: Slowly tighten the screws using the sequence indicated in Figure 82.

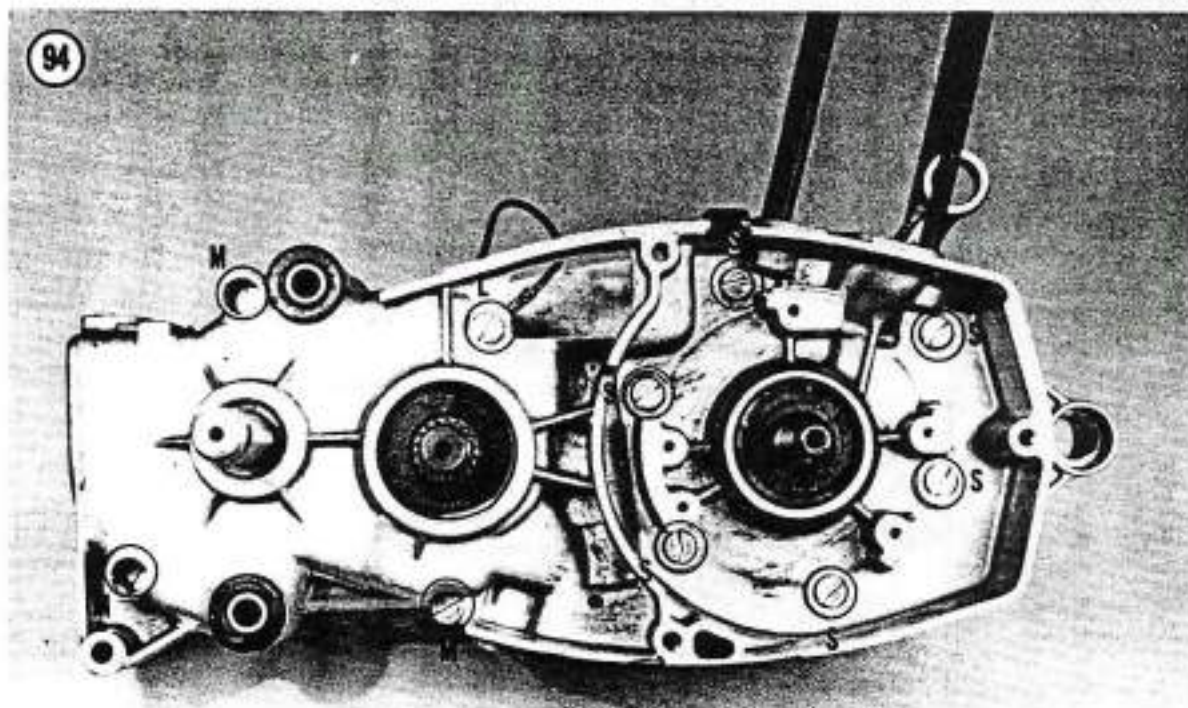
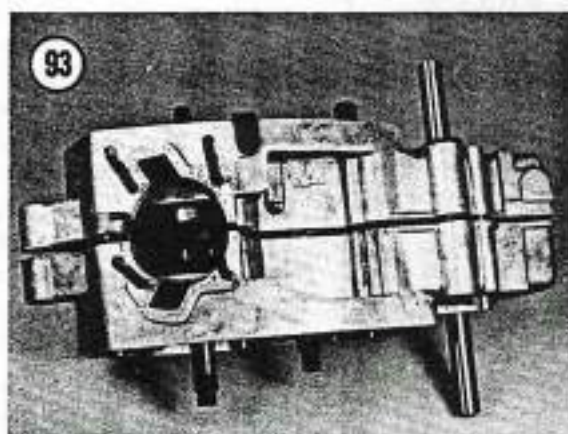
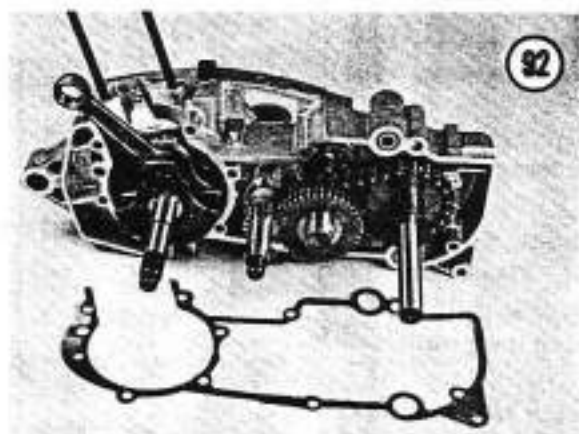

8. Check that the shafts rotate freely. If they do not, tap on each end of the shafts with a plastic mallet. This should free them.

CRANKSHAFT

If the crankshaft or the connecting rod needs to be replaced they must be replaced as a unit. This assures that the accuracy of the fit between them is correct.

Bearing and Seal Replacement

1. Disassemble the crankcase as described under *Crankcase Disassembly/Assembly* in this chapter.
2. Place the crankcase halves in an oven and heat to 212°F (100°C). An easy way to check to see that it is at proper temperature is to drop tiny drops of water on the cases. If the water sizzles and evaporates immediately the temperature is correct.
3. Remove from oven and hold 2 studs with a kitchen pot holder, heavy gloves or heavy shop cloths — they are *hot!*

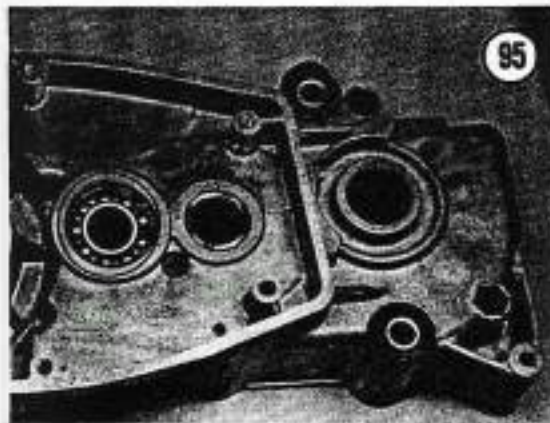

4. Hold the crankcase half with the bearing side down and tap it on a piece of soft wood, continue to tap until the bearing falls out. Repeat for the other half.

CAUTION

Be sure to tap the crankcase squarely on the piece of wood. Avoid damaging the surface of the crankcase as it forms a seal when the 2 halves are assembled.

5. Let the crankcase halves cool so that they are easier to handle. Remove the seals by pressing them out with a suitable size socket, pipe, or piece of wood.
6. After removal of the bearings and seals, thoroughly clean both crankcase halves with cleaning solvent and dry completely.
7. Press the seals into place. *Make sure that the flush side of the seal is out toward the outside of the engine.*
8. Reheat the crankcase halves to the same temperature as in Step 2 and insert the bearings. They should slip right into place, if not tap them in with a plastic mallet—very gently all around the outer perimeter of the bearing. *Make sure they are completely seated.*

NOTE: *On Gran Sport Twin models, be sure that the main shaft bearing snap ring (Figure 95) is installed in the left-hand crankcase. This is used to properly locate the bearing.*

9. After the bearings and seals are installed, lightly oil them. This will aid in the final assembly of the parts into the crankcases.
10. Assemble the crankcase halves as described under *Crankcase Assembly/Disassembly* in this chapter.

CHAPTER SIX

CLUTCH/TRANSMISSION

Service procedures for the different clutch/transmissions are virtually the same. Where there are differences, they are identified.

The engine power is transmitted to the rear wheel through a clutch/transmission. The clutch is automatic and uses a rubber ring, or rings, that expand, at proper engine speed, driving the rear wheel.

The clutch is used for starting the engine — by pedaling the moped and pulling on the clutch start lever on the left handlebar (**Figure 1**). The lever pivots the start arm into the clutch mechanism compressing the clutch components together.

Prior to removing the clutch, clean off all dirt, grease, oil and foreign matter. Use a cleaner designed specifically for this purpose, like Gunk Cycle Degreaser or equivalent. Follow the manufacturer's directions and avoid using too high a water pressure when rinsing off.

CLUTCH

Removal (Eureka, Sport, Gran Sport, Super Sport XL)

Refer to **Figure 2** (page 64) for this procedure.

1. Place moped on the centerstand.
2. Remove the rubber mat and remove the 4 bolts securing the engine fairing (**Figure 3**), and remove it.

3. Place a drip pan under the clutch housing, remove the drain plug (**Figure 4**), and completely drain the oil. Let it drain for at least 10 minutes. Install the drain plug.

4. Push in on the clutch start arm (**Figure 5**) and unhook the end of the clutch cable (**Figure 6**).

5. Remove the 6 screws securing the engine/clutch side cover (**Figure 7**) and remove it.

6. Remove the circlip (**Figure 8**) using a pair of circlip pliers (**Figure 9**).

7. Remove the starter disc and clutch rubber (**Figure 10**). They will come off as one unit.

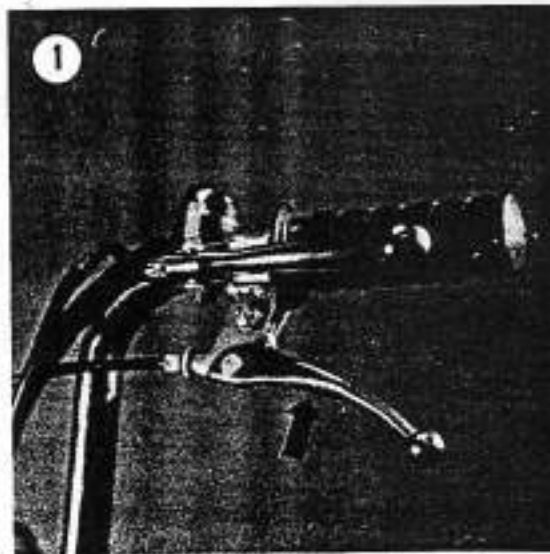

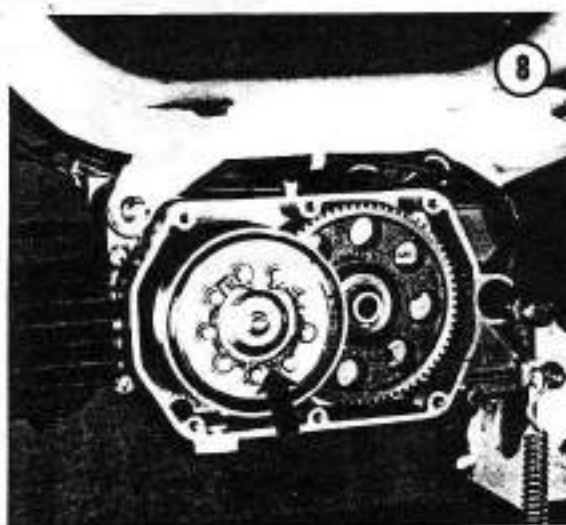
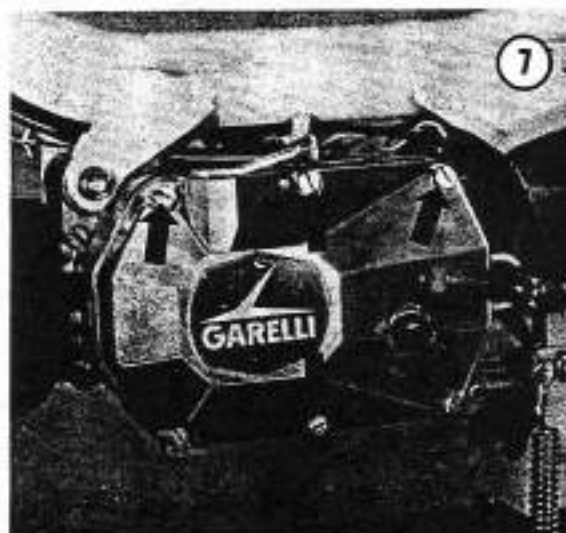
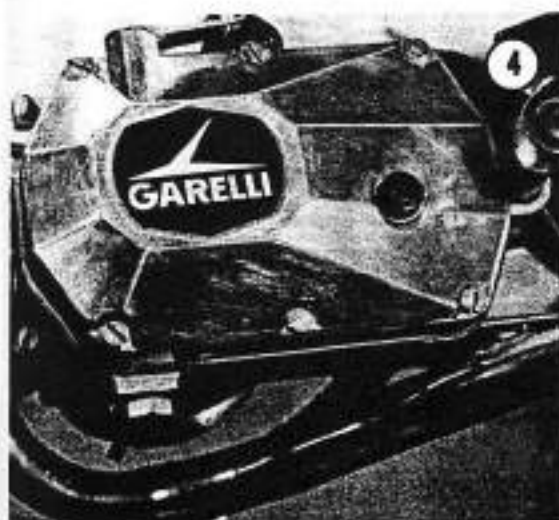
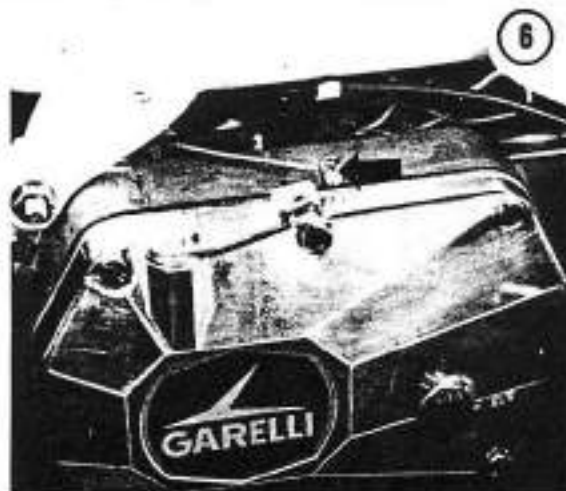
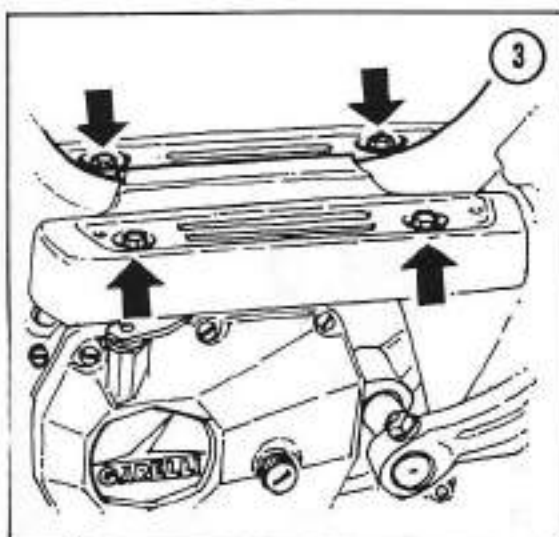

6

CLUTCH
(EUREKA, SPORT, GRAN SPORT, SUPER SPORT XL)

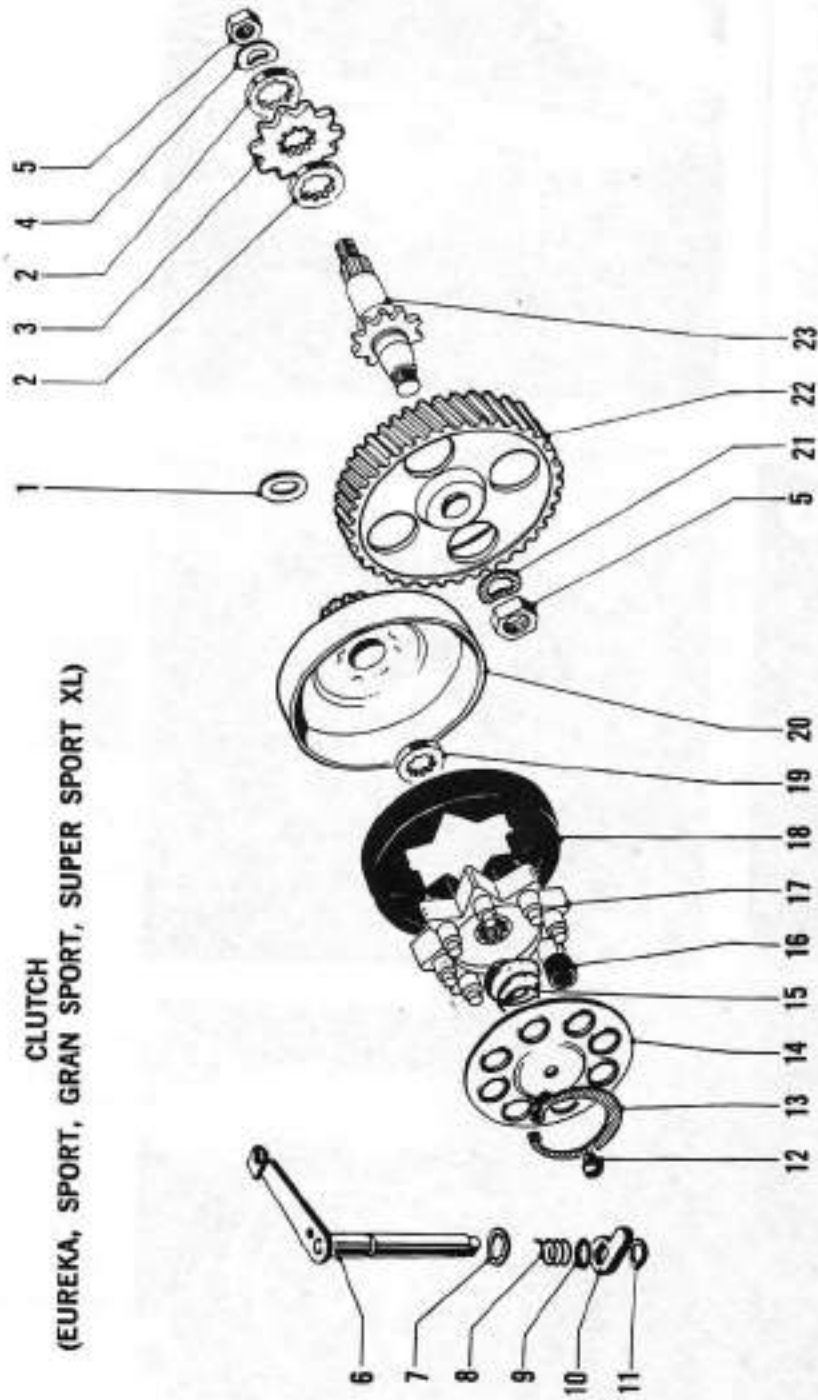

2

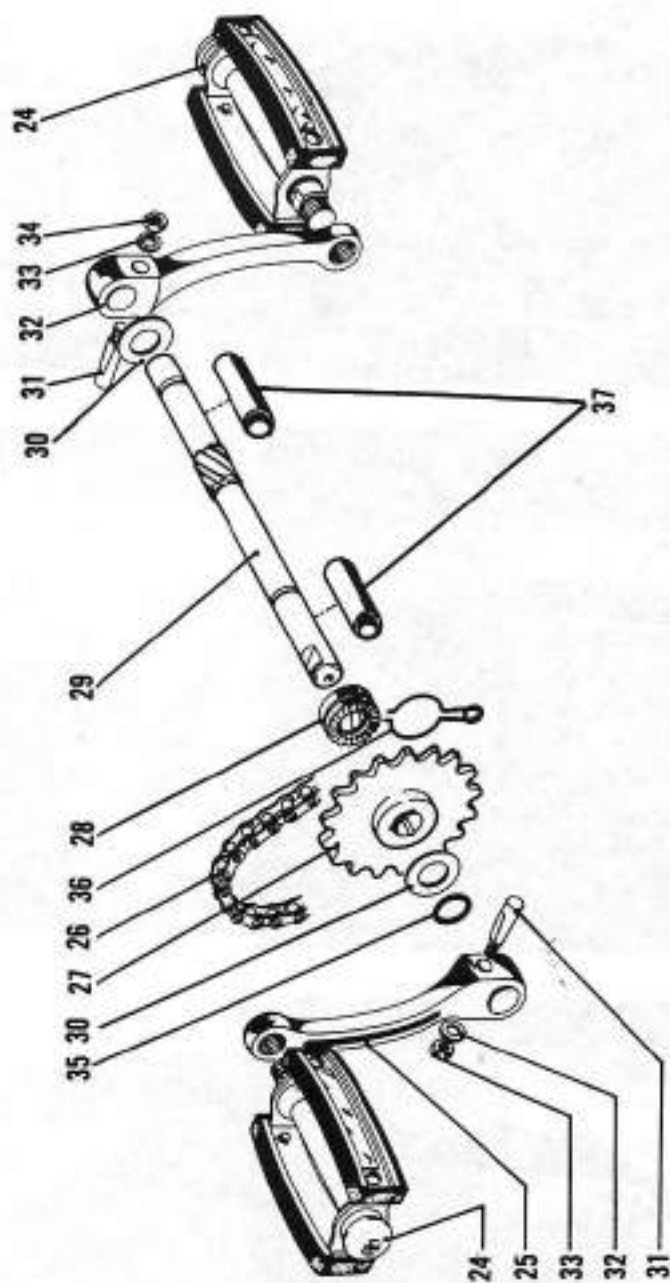

- 1. Washer
- 2. Splines washer (2)
- 3. Sprocket
- 4. Washer
- 5. Nut (2)
- 6. Clutch start arm
- 7. Washer
- 8. Spring
- 9. Ring seal
- 10. Start lever
- 11. Circlip
- 12. Pivot pin
- 13. Circlip
- 14. Starter disc
- 15. Spring
- 16. Rubber bushing (6)
- 17. Clutch hub
- 18. Clutch rubber
- 19. Splines washer
- 20. Clutch housing/driven gear
- 21. Spring washer
- 22. Driving gear
- 23. Main shaft
- 24. Pedals (pair)
- 25. Crank arm — left-hand
- 26. Chain
- 27. Starting sprocket
- 28. Clutch coupling
- 29. Pedal shaft
- 30. Washer (2)
- 31. Cotter pin (2)
- 32. Crank arm — right-hand
- 33. Washer (2)
- 34. Nut (2)
- 35. Ring seal
- 36. Return spring
- 37. Protective sleeves (2)

6

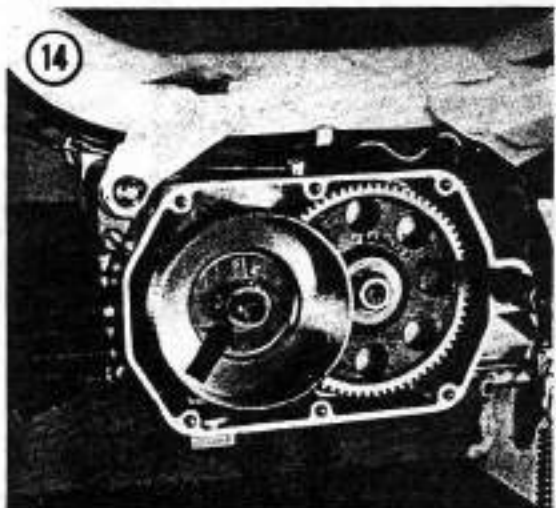
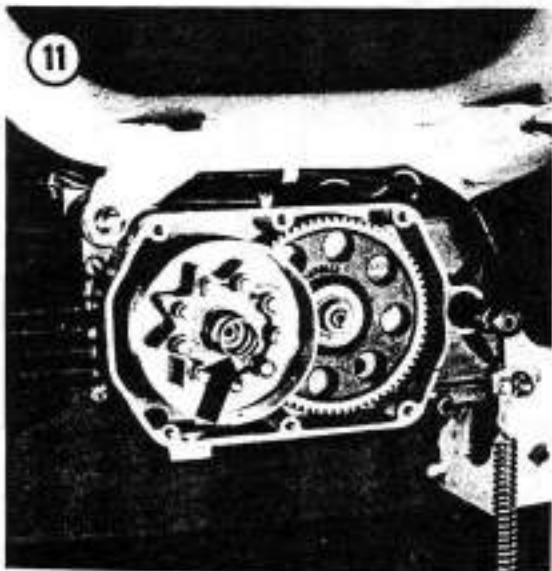
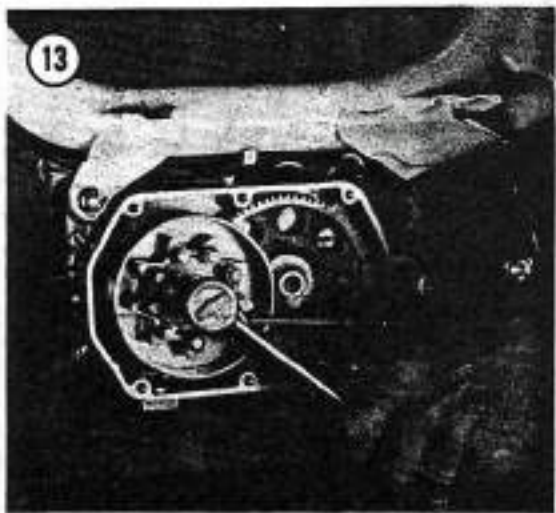
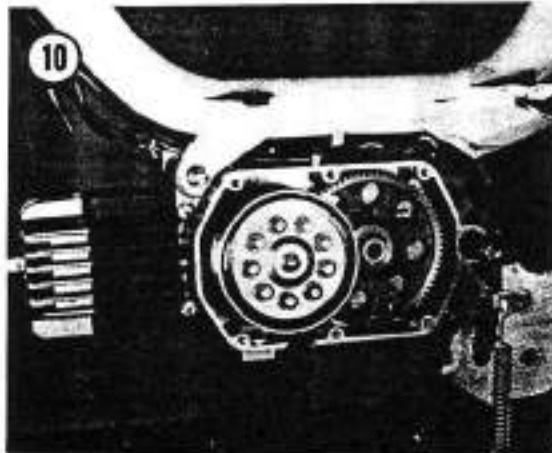
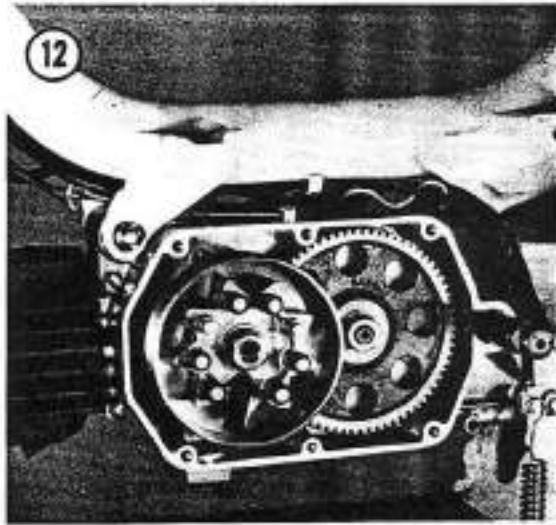
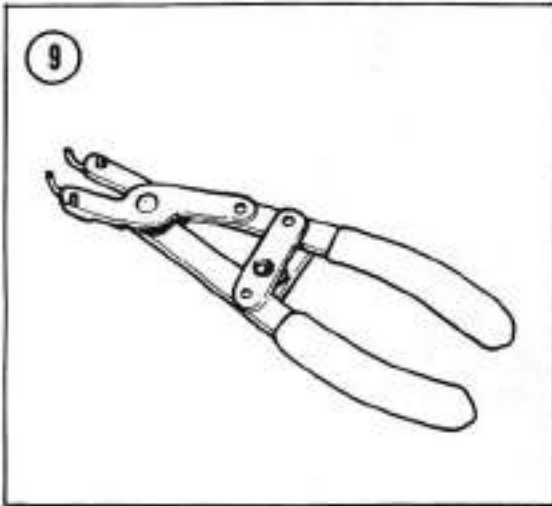

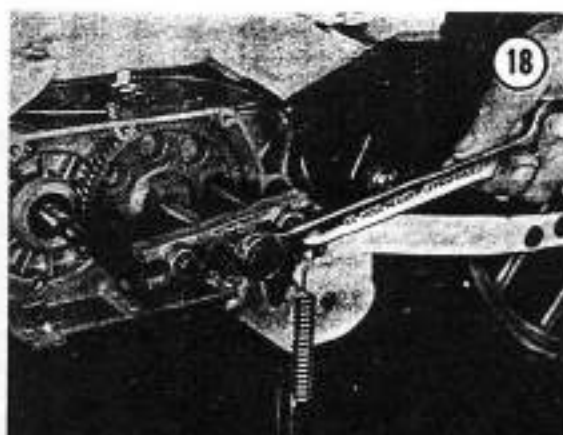
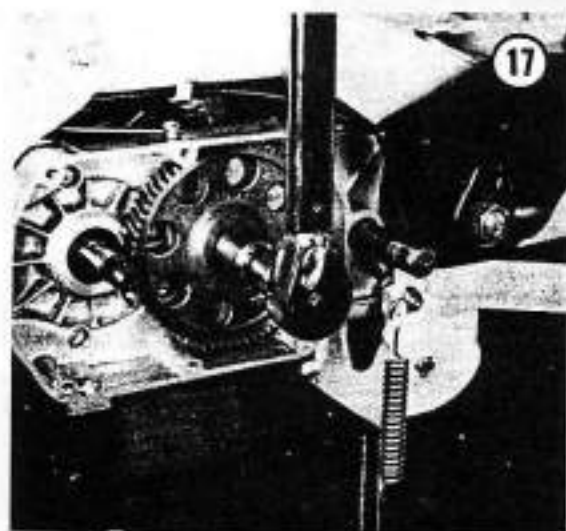
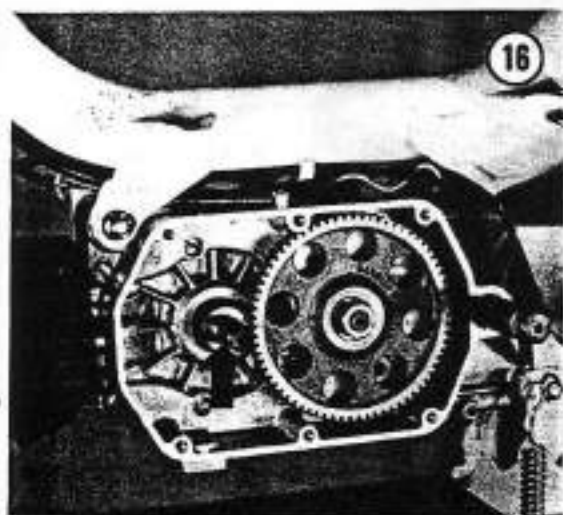
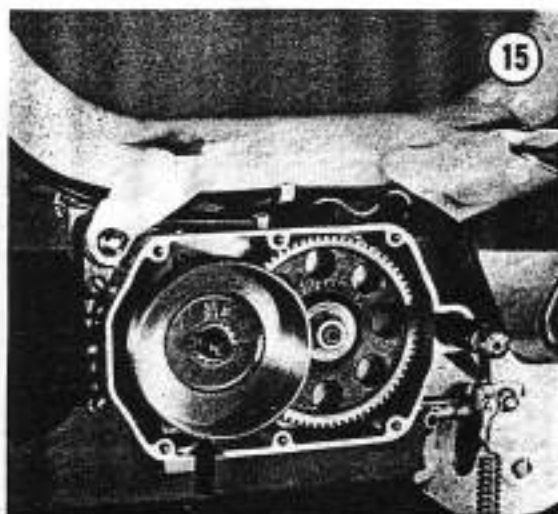

8. Remove the spring (Figure 11).
9. Remove the nut (Figure 12) with a 17mm socket and remove the clutch hub.

NOTE: To prevent the clutch hub from rotating, place the blade of a large screwdriver between the pins on the clutch hub and place the handle under the crank arm (Figure 13).

10. Remove the spline washer (Figure 14), the clutch housing/driven gear (Figure 15), and washer (Figure 16).

11. Remove the nut (Figure 17) on the driving gear with a 17mm socket or impact driver.

NOTE: To prevent the gear from rotating while removing the nut, have an assistant hold the rear brake on to prevent the rear wheel, chain, and driving gear from turning.

12. Attach a gear puller (Figure 18) to the driving gear and remove the gear. Gear pullers can be rented from most tool rental dealers or motorcycle parts stores.

NOTE: This gear is on a tapered shaft and it may be difficult to free it from this shaft. If necessary, tap the gear with a drift punch and hammer several times in several places toward the center of the gear (Figure 19).

CAUTION

Do not use the engine crankcase for leverage while trying to remove any parts. The crankcase will fracture or chip if stressed in any way other than what it is designed for.

Installation (Eureka, Sport, Gran Sport, Super Sport XL)

1. Install the driving gear and nut. Torque the nut to 35 ft.-lb. (47 N•m).

NOTE: To prevent the gear from rotating while tightening the nut, have an assistant hold the rear brake on to prevent the rear wheel, chain, and driving gear from turning.

2. Install the washer (Figure 16), the clutch housing/driven gear (Figure 15), and the spline washer (Figure 14).

NOTE: Install the washer (Figure 16) with the ground or smooth side in toward the engine.

3. Install the clutch hub and nut (Figure 12). Torque the nut to 23 ft.-lb. (31.2 N•m).

NOTE: To prevent the clutch hub from rotating while tightening the nut, place the blade of a large screwdriver between the pins on the clutch hub and rest the handle on the crank arm (Figure 20).

NOTE: After the nut has been tightened, check to see that the clutch hub turns independently from the clutch housing/driven gear. If it will not, remove the nut and the clutch housing/driven gear and turn the washer (Figure 16) around. Repeat Step 3.

4. Insert the spring (Figure 11) and install the starter disc and clutch rubber (Figure 10).
5. Push in on the starter disc and install the circlip. The locating tab can fit between any of the pins on the clutch hub.

CAUTION

Make sure that the circlip is properly seated in ALL the grooves in the pins of the clutch hub.

6. Make sure that the gasket surfaces of both the crankcase and the engine/clutch cover (Figure 21) are clean. Apply gasket cement to one side of the new gasket and place this side on the engine/clutch cover.

7. Install the engine/clutch cover.

NOTE: The 2 short bolts (A) are used at the rear (Figure 22).

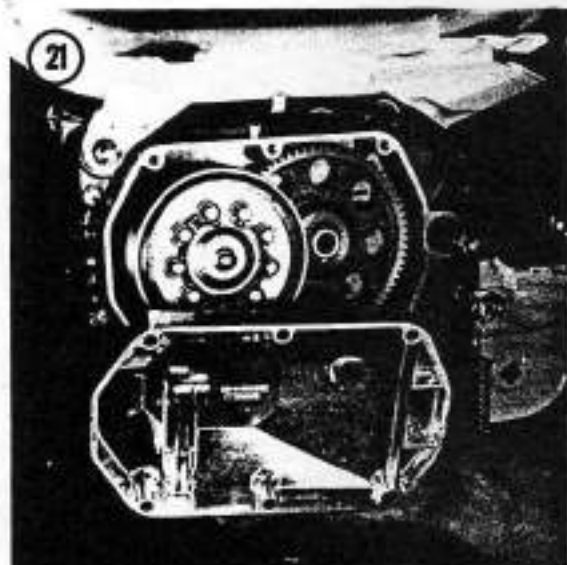
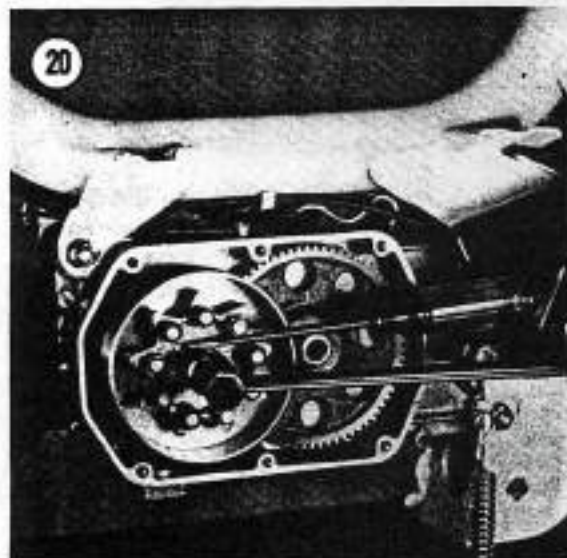

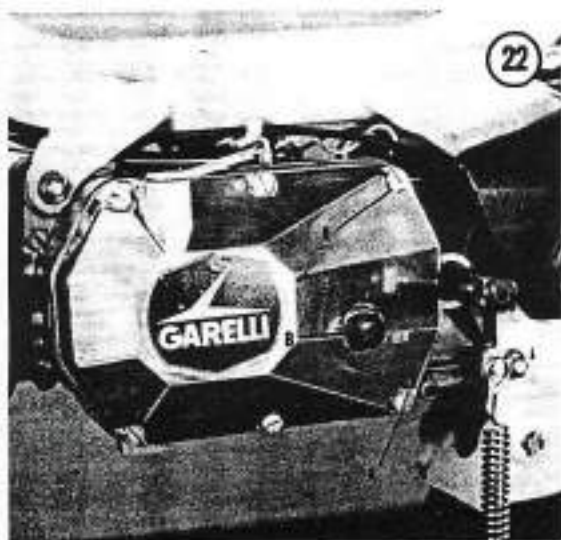

8. Remove the fill cap (B, Figure 22) on the engine/clutch cover, and fill with 13.5 oz. (400cc) SAE 30 non-detergent oil.

CAUTION

Do not use detergent oil.

NOTE: In order to measure the correct amount of oil, use a plastic baby bottle. These have measured increments in fluid ounces (oz.) and cubic centimeters (cc). See Figure 23.

9. Install the fill cap (B, Figure 22), start the engine and check for leaks.

Removal (Gran Sport Twin)

Refer to Figure 24 (on the following 2 pages) for this procedure.

1. Place the moped on the centerstand.
2. Remove the 2 screws securing the step plate (Figure 25) and remove it.
3. Remove the screw (Figure 25) securing each engine fairing and remove them.
4. Place a drip pan under the clutch housing, remove the drain plug (Figure 26) and completely drain the oil. Let it drain for at least 10 minutes. Install the drain plug.
5. Push in on the clutch start arm (Figure 27) and unhook the end of the clutch cable.
6. Remove the 6 screws securing engine/clutch side cover (Figure 28) and remove it.
7. Remove the start plate (Figure 29) by pulling it off the rubber nibs.

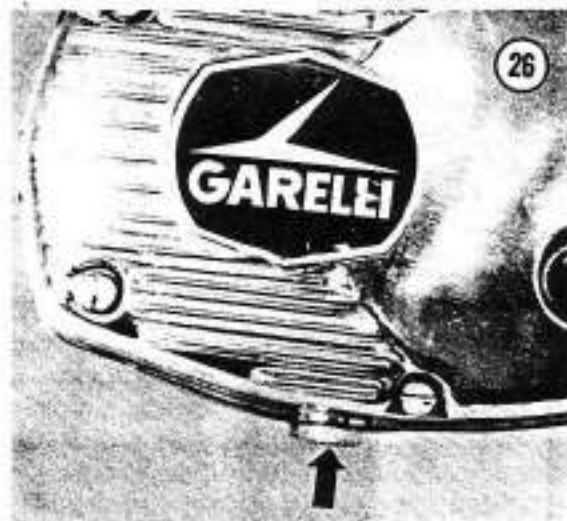
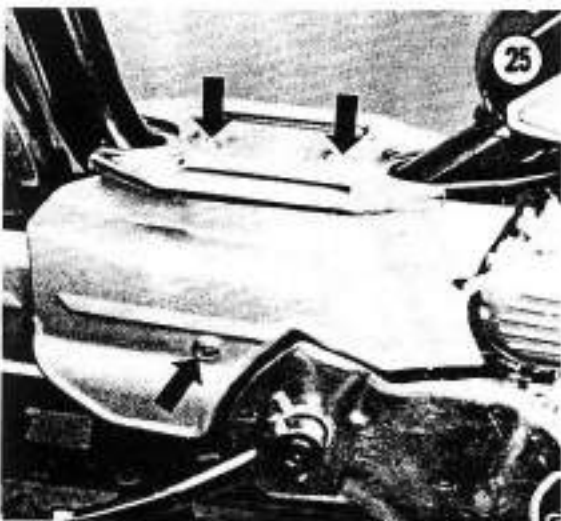
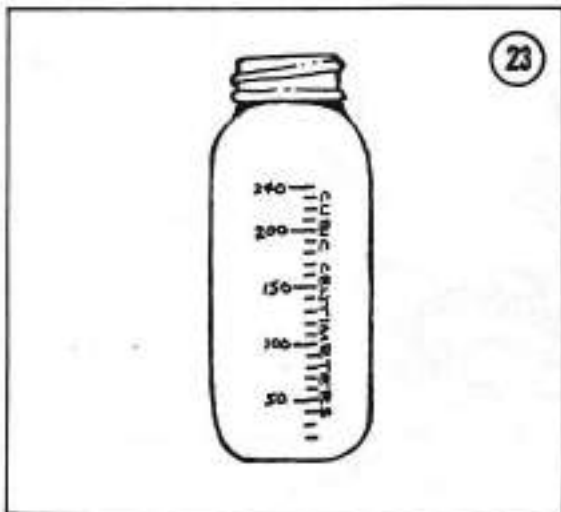

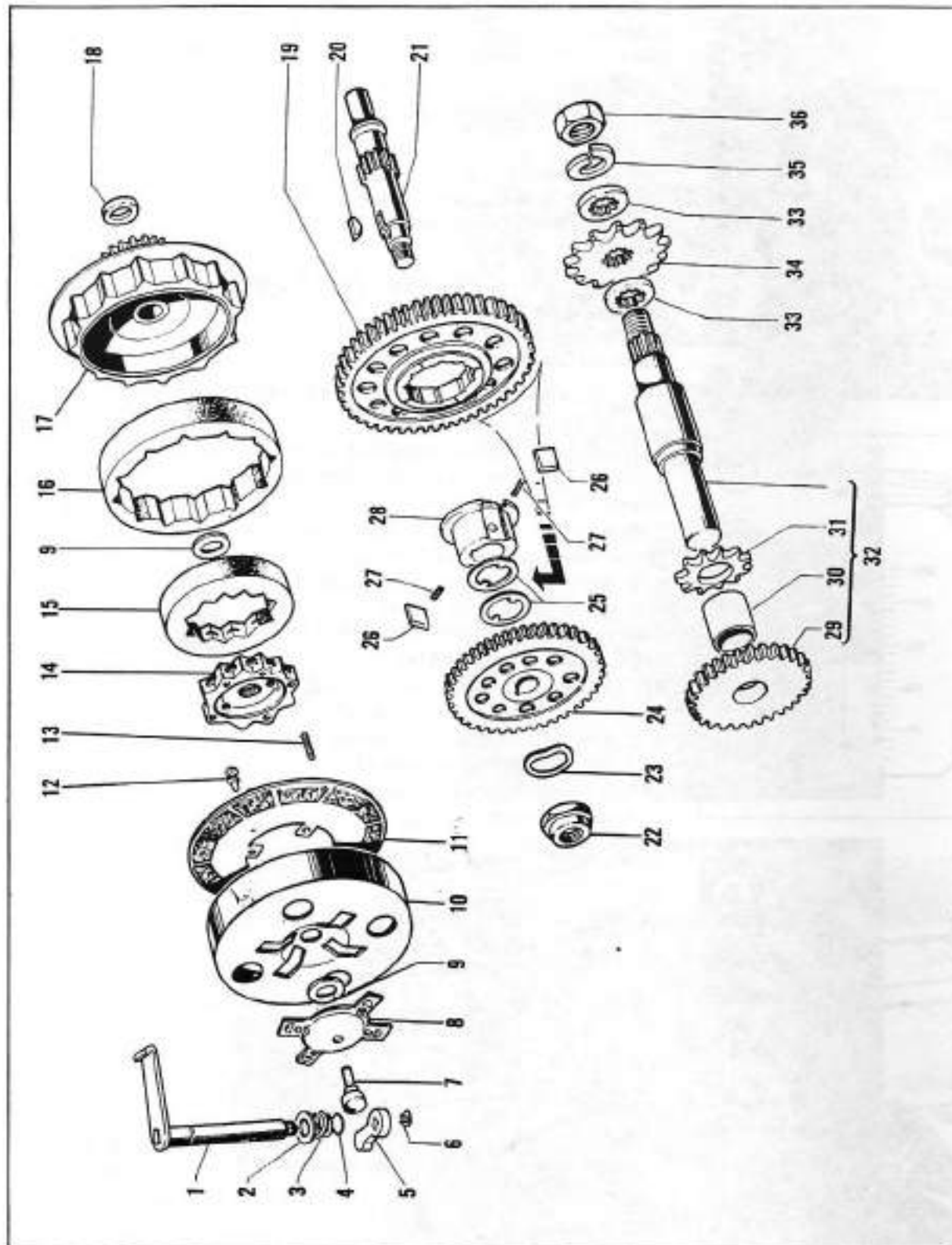

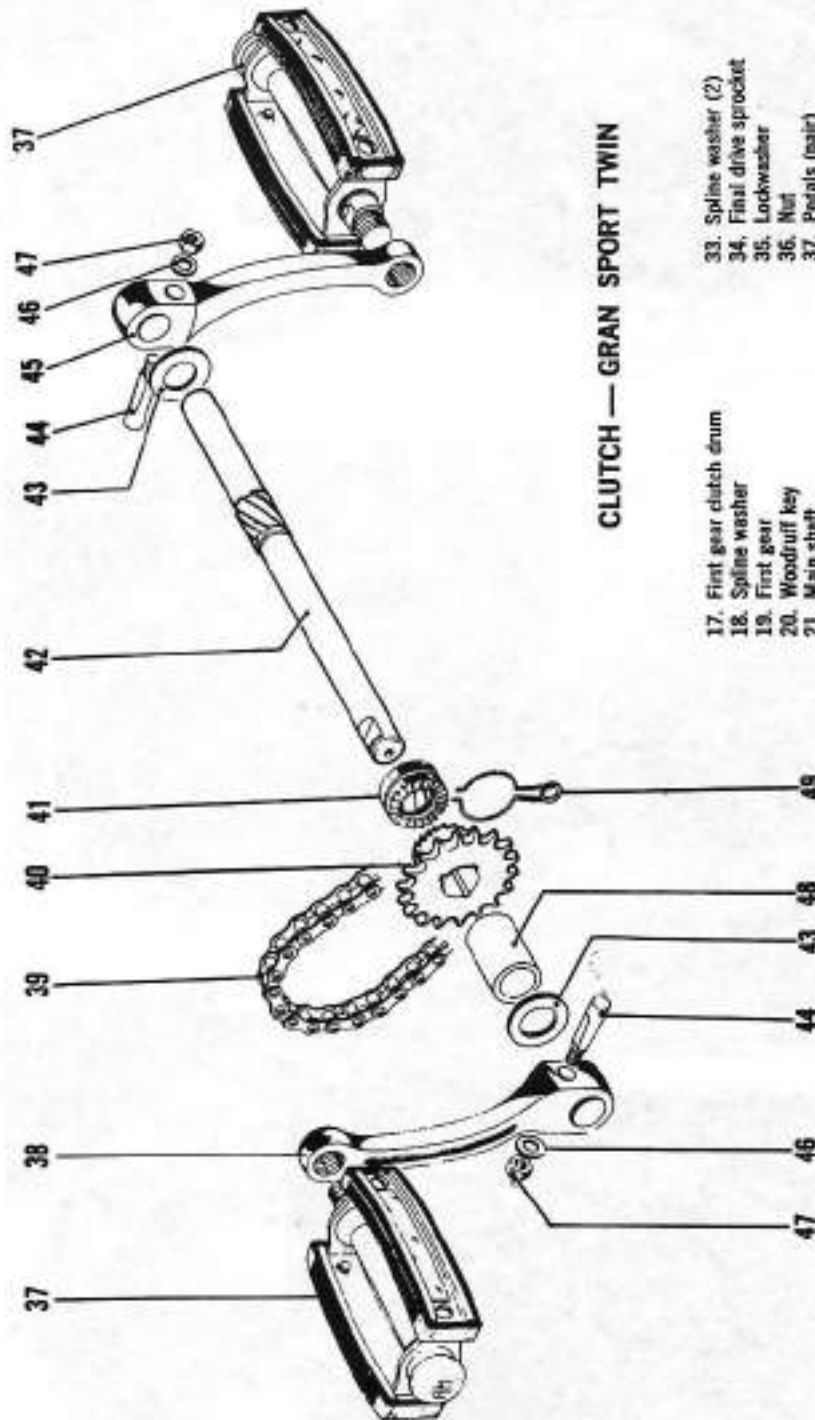

CLUTCH — GRAN SPORT TWIN

1. Clutch start arm
2. Washer
3. Spring
4. Ring seal
5. Start lever
6. Circlip
7. Pivot pin
8. Start plate

9. Washer
10. Second gear clutch drum
11. Lined clutch plate
12. Rubber ribs (4)
13. Coil springs (5)
14. Clutch center
15. First gear clutch rubber
16. Second gear clutch rubber

17. First gear clutch drum
18. Spline washer
19. First gear
20. Woodruff key
21. Main shaft
22. Nut
23. Washer
24. Second gear
25. Washer
26. Ratchet (2)
27. Coil spring (2)
28. Free wheel body
29. Second gear pinion
30. Spacer
31. Starting sprocket
32. Secondary shaft assembly

33. Spline washer (2)
34. Final drive sprocket
35. Lockwasher
36. Nut
37. Pedals (pair)
38. Crank arm — left-hand
39. Chain
40. Starting sprocket
41. Clutch coupling
42. Pedal shaft
43. Washer (2)
44. Cotter pin (2)
45. Crank arm — right-hand
46. Washer (2)
47. Nut (2)
48. Spacer
49. Return spring

24

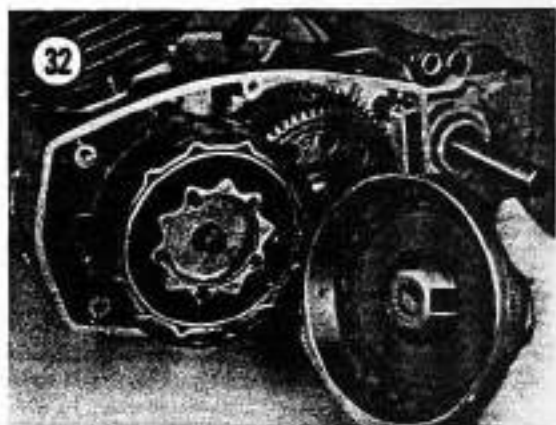
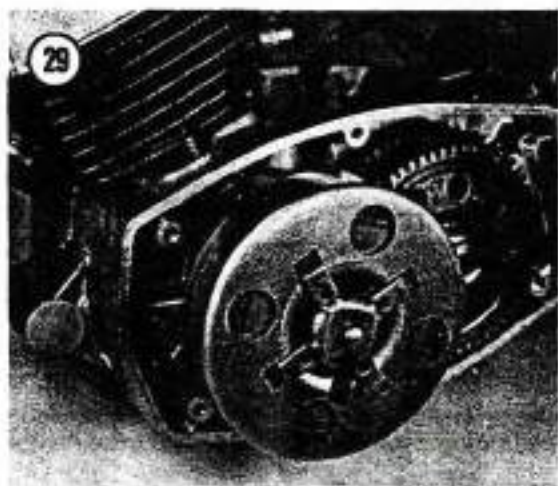
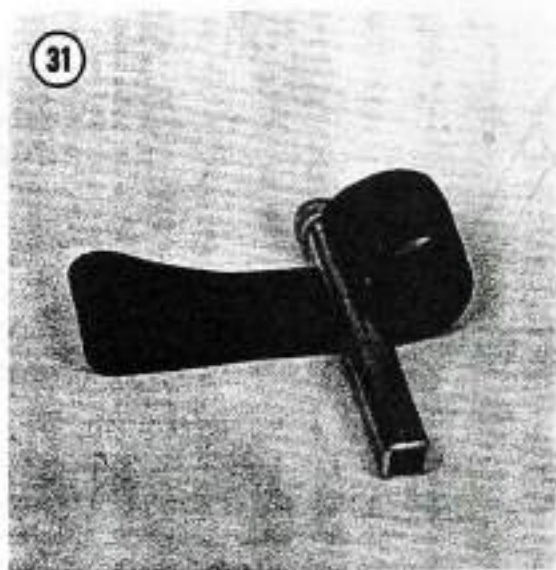
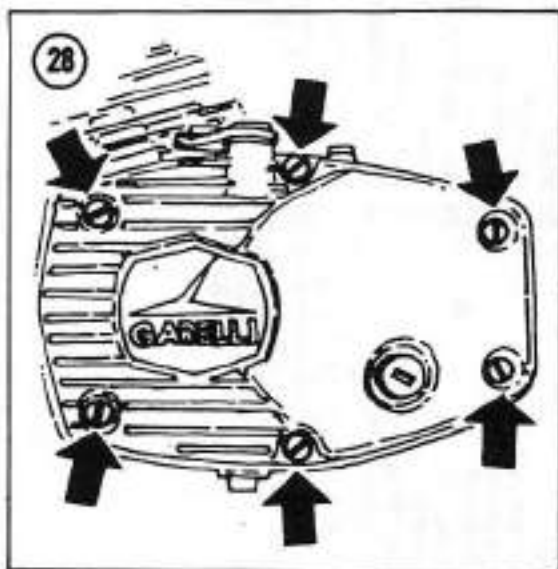
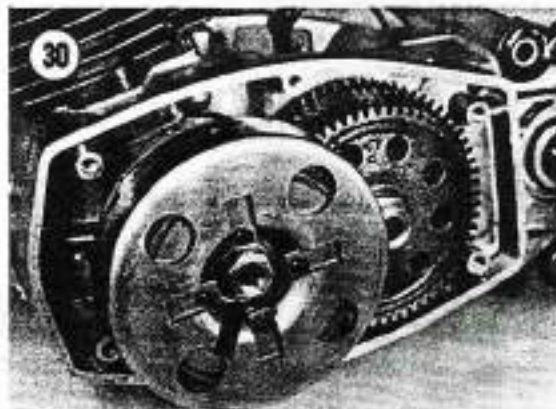
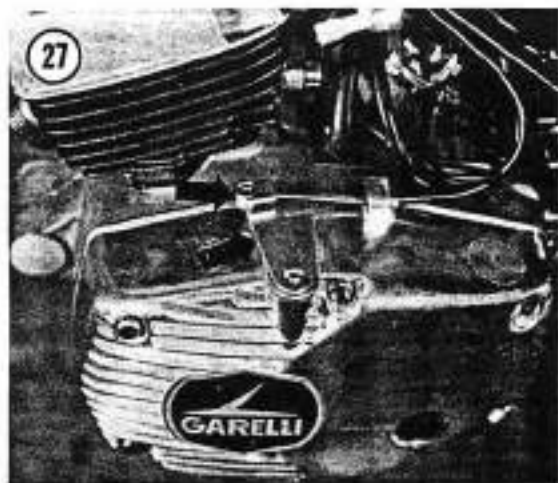

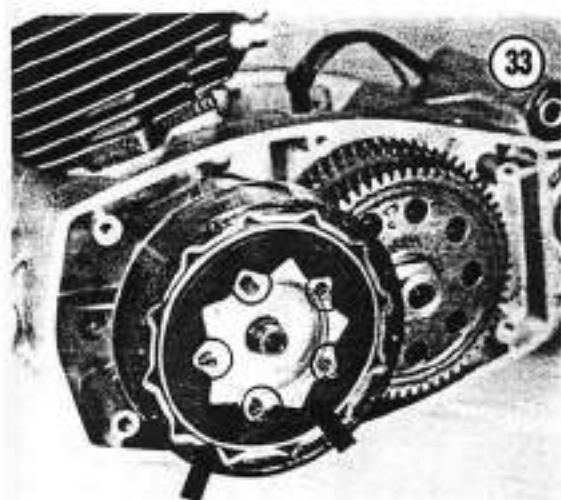

8. Remove the nut and washer (Figure 30) from the crankshaft with an impact driver.

NOTE: To prevent the crankshaft from rotating while removing the nut, have an assistant hold the magneto rotor by hand or with a strap wrench (Figure 31).

9. Remove the second gear clutch drum and the lined clutch plate (Figure 32).

10. Remove the clutch center and the first gear rubber (Figure 33). Do not lose any of the 5 coil springs in the clutch center.

11. Remove the spline washer (Figure 34), the first gear clutch drum and the second gear clutch rubber (Figure 35), and the washer (Figure 36).

12. Remove the nut and washer (Figure 37) from the main shaft.

NOTE: To prevent the main shaft from rotating while removing the nut, have an assistant hold the magneto rotor by hand or with a strap wrench (Figure 31).

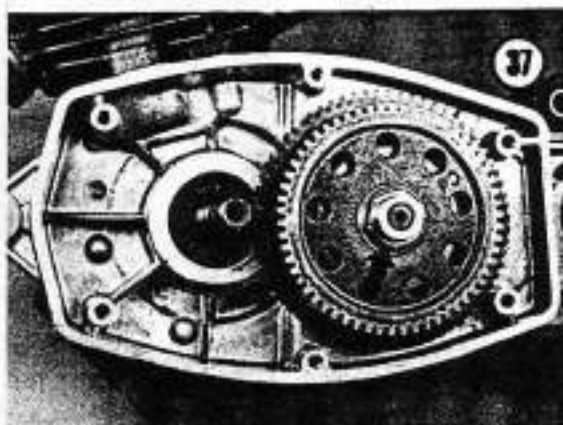
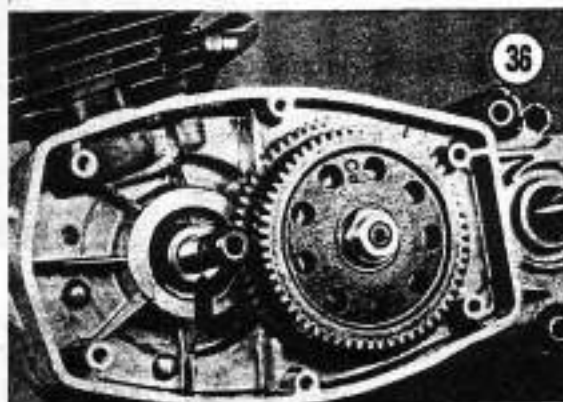
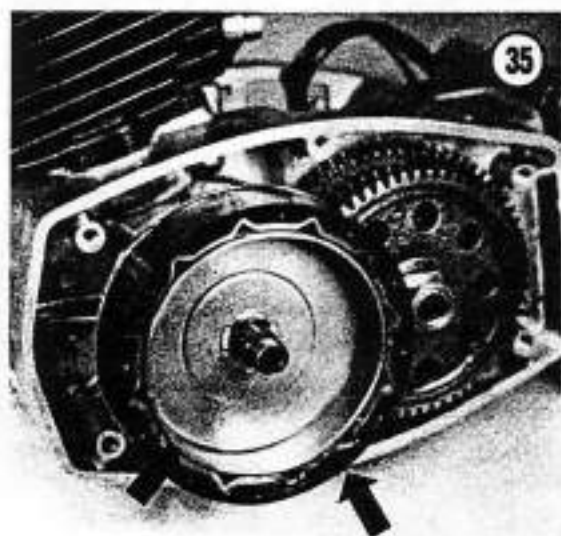
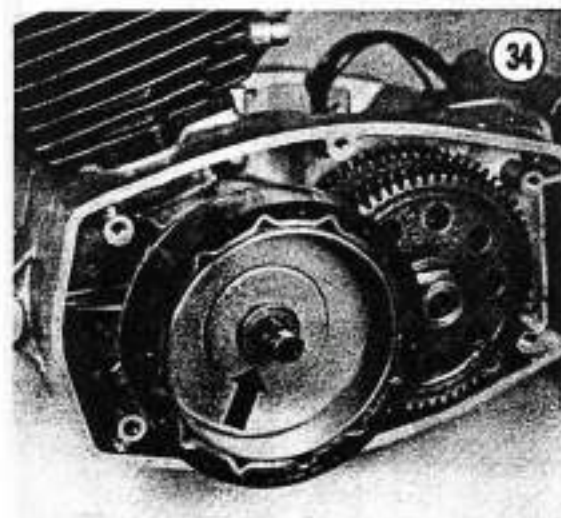

13. Remove the second gear (Figure 38), the first gear complete with the free wheel, ratchets, and washers (Figure 39).

CAUTION

Do not use the engine crankcase for leverage while trying to remove any parts. The crankcase will fracture or chip if stressed in any way other than what it is designed for.

14. Remove the Woodruff key and the flat washer (Figure 40) from the main shaft.

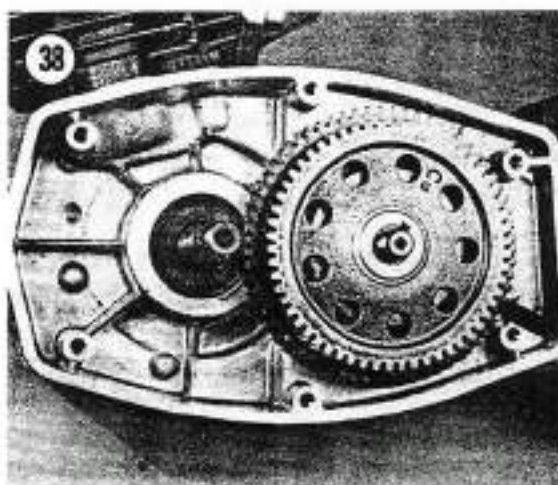

Installation (Gran Sport Twin)

1. Install the flat washer and the Woodruff key (Figure 40) onto the main shaft.
2. Install the washer, free wheel body, coil springs, and the ratchets into the center of the first gear (Figure 41).
3. Install the first gear with all of the components assembled in Step 2 onto the main shaft. Install the gear with the concave side of the gear toward the crankcase (Figure 39). Hold the washer against the backside of the gear when installing.
4. Install the second gear (Figure 38) with the concave side of the gear toward the first gear.
5. Install the washer and the nut (Figure 37). Torque the nut to 60 ft.-lb. (81 N•m).

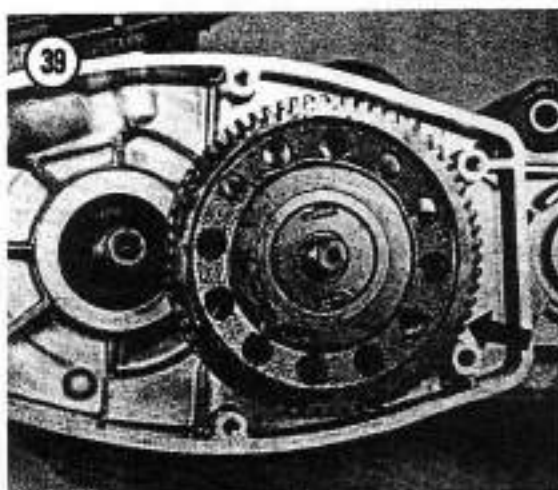

NOTE: *To prevent the gear from rotating while tightening the nut, have an assistant hold the magneto rotor by hand or with a strap wrench (Figure 31).*

6. Install the washer (Figure 36) and the first gear clutch drum and second gear clutch rubber (Figure 35) onto the crankshaft.
7. Install the spline washer (Figure 34).
8. Install the clutch center and the first gear clutch rubber (Figure 33). Install the clutch center with the spring side out.

NOTE: *Make sure all 5 springs are in place within the holes in the clutch center.*

9. Install the lined clutch plate, with the rubber nibs toward the outside, into the second gear clutch drum and install them onto the crankshaft (Figure 42).

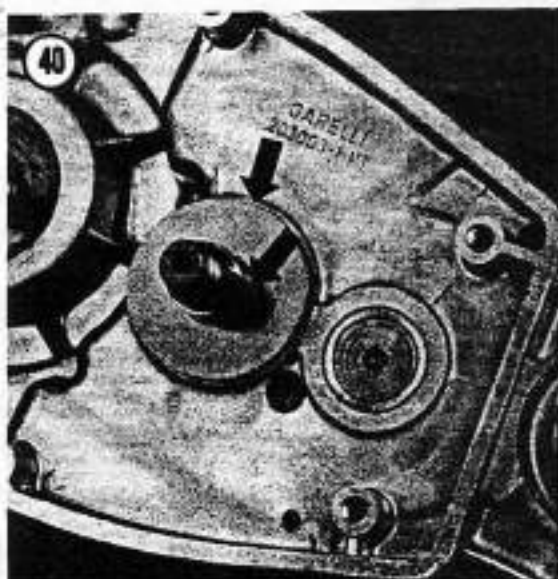

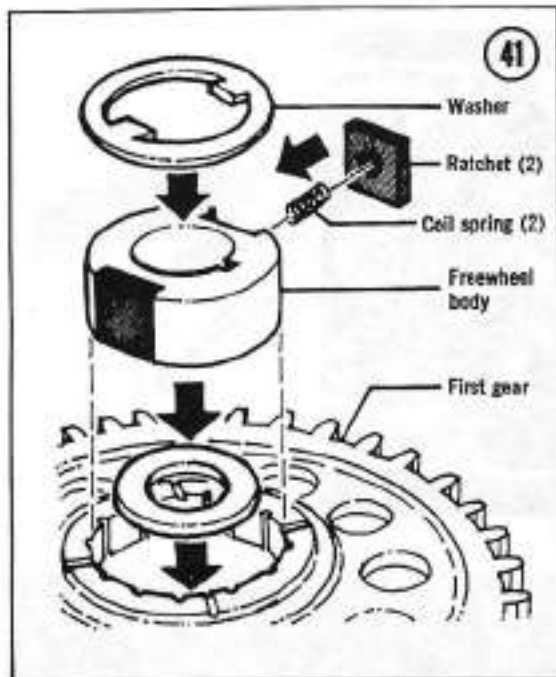

10. Install the spring washer and the nut (Figure 30). Torque the nut to 28 ft.-lb. (38 N*m).

NOTE: To prevent the crankshaft from rotating while tightening the nut, have an assistant hold the magneto rotor by hand or with a strap wrench (Figure 31).

11. Install the start plate (Figure 29) by pressing it onto the rubber nibs on the lined clutch plate.

12. Make sure that the gasket surfaces of both the crankcase and the engine/clutch cover are clean. Apply gasket cement to one side of the new gasket and place this side onto the engine/clutch cover.

13. Install the engine/clutch cover.

NOTE: The front 2 screws have fiber washers behind them. This is for sealing purposes — Do not forget to install them.

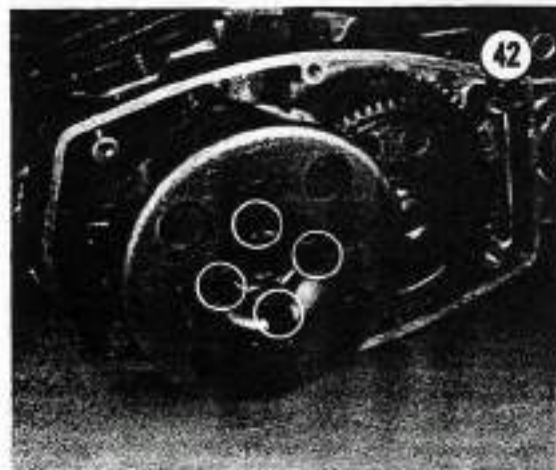

14. Remove the fill cap (Figure 43) on the engine/clutch cover, and fill with 13.5 oz. (400cc) SAE 30 non-detergent oil.

CAUTION
Do not use detergent oil.

NOTE: In order to measure the correct amount of oil, use a plastic baby bottle. These have measured increments in oz. and cc (Figure 23).

15. Install the fill cap (Figure 43), start the engine, and check for leaks.

Inspection (Eureka, Sport, Gran Sport, Super Sport XL)

Refer to Figure 2 for this procedure.

1. Check the clutch rubber for signs of fatigue, cracking, or wear. It can be separated from the starter disc by pulling the 2 parts apart. Replace if necessary.

NOTE: If the clutch rubber and the starter disc have been separated for inspection, they must be put back together so that the holes in the starter disc align with the V-notches in the clutch rubber. This is necessary so that the assembled unit will match up with the clutch hub.



2. Inspect the rubber bushings on the clutch hub. If they are cracked or show signs of wear, replace all of them. There are only 6, as every third pin does not use one (Figure 44).
3. Check the pivot pin on the starter disc for signs of wear; replace if necessary.
4. Check the inside surface of the clutch housing/driven gear for scratches and distortion. Replace if necessary.
5. Inspect the teeth on the gear of the clutch housing/driven gear and the driving gear. If any of the teeth are damaged or missing, both parts should be replaced.
6. Check the spring for signs of fatigue. Check the overall length of the spring in a relaxed position against a new one. If the old one is shorter by $\frac{1}{4}$ in. (6mm), it should be replaced.

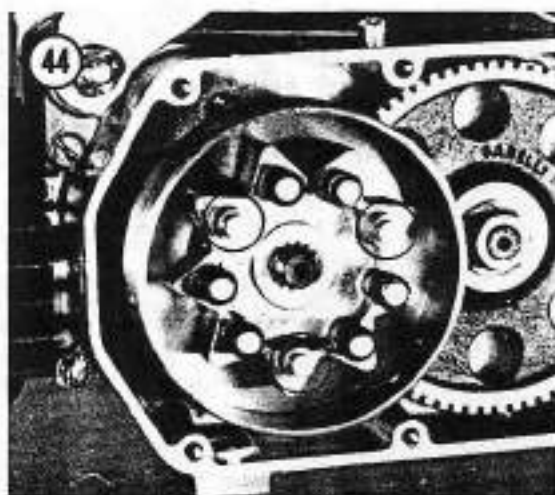

Inspection (Gran Sport Twin)

Refer to Figure 24 for this procedure.

1. Check the clutch rubbers for signs of fatigue, cracking, or wear.
2. Check the inside surfaces of the first gear drum and the second gear clutch drum for scratches and distortion. Replace if necessary.
3. Check the pivot pin on the start plate for signs of wear; replace if necessary.
4. Check the 5 coil springs of the clutch center for signs of wear or distortion. Replace all of them if any are bad.
5. Inspect the teeth of the first and second gear. If any of the teeth are damaged or missing, they must be replaced.
6. Check the 4 rubber nibs on the lined clutch plate; if they are worn or missing, all 4 must be replaced.
7. Inspect the 2 springs on the ratchets (of the free wheel body); make sure they are not bent; replace if necessary.

45

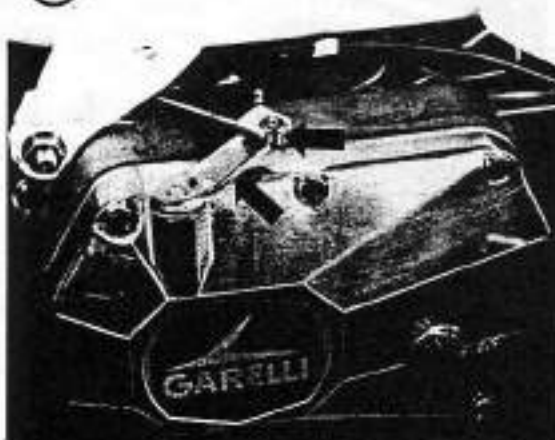

46

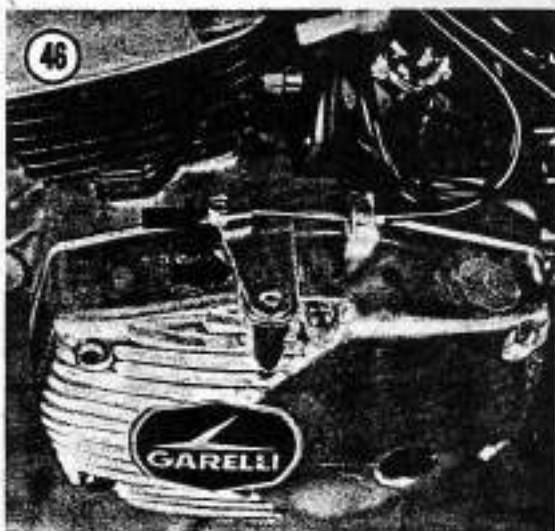

Clutch Start Cable Removal/Installation

In time, the cable will stretch to the point where it is no longer useful and will have to be replaced.

1. Push in on the clutch start arm (Figure 45) or (Figure 46) and unhook the end of the clutch cable.

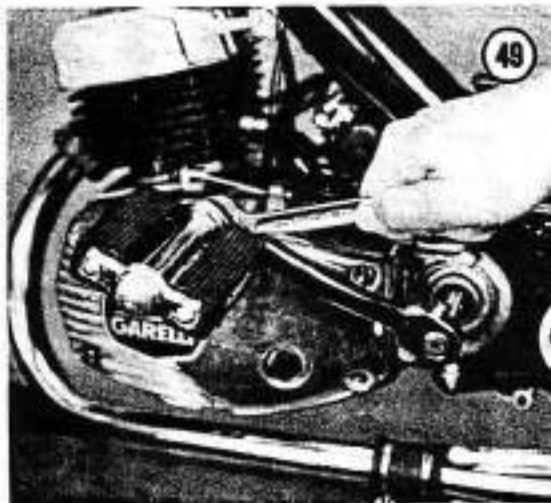
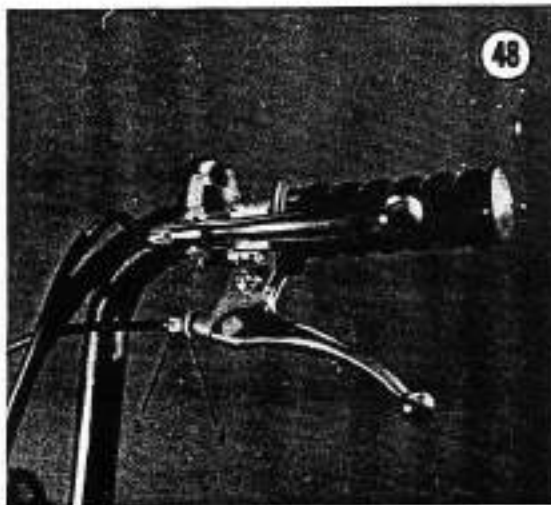
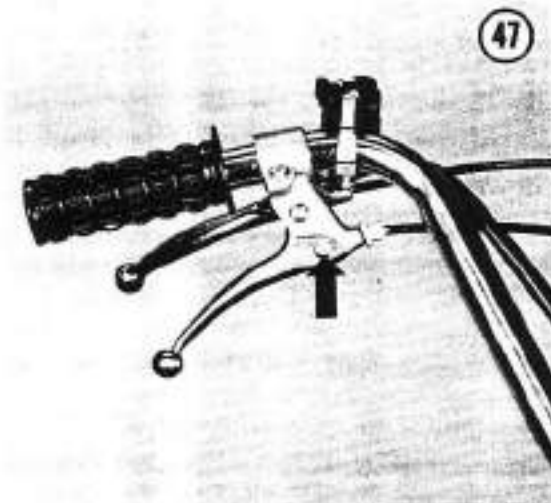

NOTE: Prior to removal of the cable, make a drawing of the routing of the cable through the frame. It is very easy to forget how it was once it has been removed. Replace it exactly as it was, avoiding any sharp turns.

2. Pull the hand lever all the way back to the grip, remove the cable nipple holder (Figure 47) and remove the cable from the lever.
3. Remove the cable from the frame and replace with the new one.
4. Adjust the cable free play as described under *Clutch Start Cable Adjustment* in this chapter.

Clutch Start Cable Adjustment

The start cable should be checked periodically to maintain free play. Free play is the distance the start lever travels between the release position and the point when the lever, on the engine cover, engages the clutch mechanism. This should be kept to a minimum.

Adjust free play by loosening the locknut (A) and turn the adjusting barrel (B) clockwise to reduce slack in the cable (Figure 48).

If proper adjustment cannot be achieved, the cable will have to be replaced. See *Clutch Start Cable Removal/Installation* in this chapter.

6

PEDALS

A bent or broken pedal is very dangerous. Replace it immediately. To remove the right pedal, use a wrench on the spindle (Figure 49) and loosen it *counterclockwise*. On a left pedal, loosen *clockwise*; the left pedal has special left-hand threads.

Take the defective pedal to your dealer. Carefully match the threads with the new pedal to guarantee an exact replacement. The threaded portion must be the same diameter and have the same number of threads-per-inch.

Install the pedal(s) by tightening the right pedal *clockwise* and the left pedal *counterclockwise*.

CRANK ARM

1. Make a cut-out in a hardwood block (Figure 50). Set it on a block of wood that is setting on the floor and hold the crankarm in a horizontal position.

2. Remove the nut and washer on cotter pin.
3. Rest the crank on the hardwood block so that the end of the cotter pin is over the cut-out (Figure 50). Have someone hold the opposite pedal securely.
4. Rap on the threaded end of the cotter pin with a brass or aluminum rod and a hammer.

NOTE: It may be necessary to use penetrating oil, like Liquid Wrench or WD-40, on the cotter pin to aid in removal.

CAUTION

Do not attempt this unless the crank is firmly supported on the hardwood block. If you pound on the cotter pin without support, the bottom bracket bearings will be damaged. In addition, do not hit the cotter pin directly with a metal hammer or steel drift as the threaded end will be damaged.

5. When the cotter pin is loose, remove it.
6. Pull off the crank.
7. Check each crank for straightness by sighting down its length. If bent, replace it with an exact duplicate.
8. Slide the crank(s) onto the axle with the cotter pin hole aligned with the axle slot.
9. Install the cotter pin with a washer and nut. Tighten the nut finger-tight.
10. Support the crank on the hardwood block as in Step 3, except with the threaded end of the cotter pin over the cut-out.
11. Drive the cotter pin in by pounding with a

plastic mallet or a hammer and brass or aluminum rod. Two or three blows should be sufficient.

12. Tighten the cotter pin nuts.
13. After about 100 miles, repeat Steps 10 through 12.

CHAIN

Inspection

The chain is one of the most severely stressed parts of the moped. Inspect the chain carefully whenever it is removed for cleaning. Pay particular attention to cracks in the rollers and pin and link plates (Figure 51). Wear on these parts will cause the chain to stretch. As a quick check of chain wear, refer to Figure 52. Replace the chain if it can be pulled away from the rear sprocket by more than $\frac{1}{2}$ the length of a link.

Cleaning and Lubrication

Chain removal is accomplished by removing the master link (Figure 53). There are master

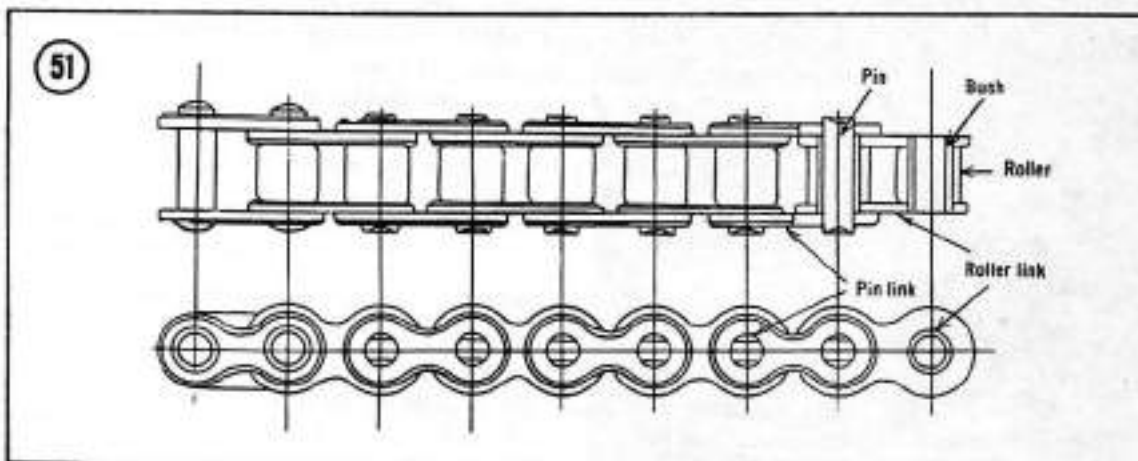
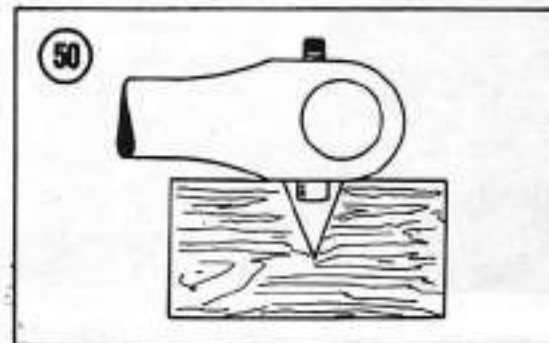

links on both chains. Removal and installation procedures are the same for both.

1. Remove the master link outer clip by prying it off with a thin bladed screwdriver.
2. Remove the outside plate and push the inside plate, complete with pins, out through the back of the chain.
3. Remove chain and soak it in cleaning solvent for about 30 minutes, to remove dirt, grease, and old chain oil. Move it around and flex it during this period so that dirt between the pins and rollers may work its way out.
4. Scrub rollers and side plates with a stiff brush, then rinse in clean solvent to carry away loosened dirt.
5. Hang chain and allow to dry thoroughly.
6. Lubricate chain with a good grade of commercial chain lubricant. Follow the lubricant manufacturer's application instructions.
7. Install by reversing the removal steps. Use a new master link clip and install it with the opening facing the opposite direction of chain travel (**Figure 53**). Incorrect installation will result in the loss of the clip and may result in chain breakage.

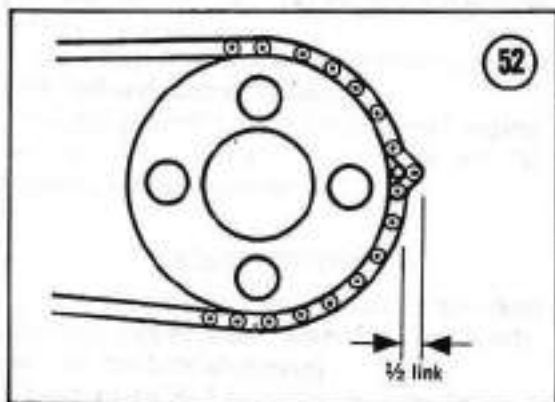

the loss of the clip and may result in chain breakage.

8. After installation of old or new drive chain, it is necessary to adjust the chain tension as described under *Drive Chain Adjustment* in this chapter. It is also necessary to adjust the rear brakes as described under *Brake Adjustment* in Chapter Nine. There is no adjustment necessary for the bicycle chain.

Drive Chain Adjustment

Proper chain tension is important. If the tension is too loose, the chain may skip while traveling at high speed. If tension is too tight, pedaling, engine effort, and chain wear increase.

The correct chain tension is measured by pressing up on the bottom of the chain at midpoint. The slack should be $\frac{1}{4}$ in. (11mm). See **Figure 54**. If the tension is incorrect use the following adjustment procedure.

1. Loosen the rear axle locknuts (A, **Figure 55**).
2. Turn the adjusting cams (B, **Figure 55**). Turning cams *clockwise* will increase tension and *counterclockwise* will decrease tension.

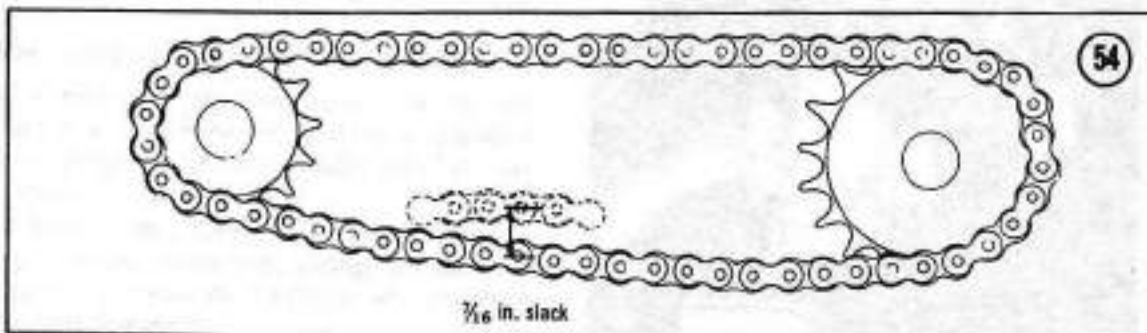
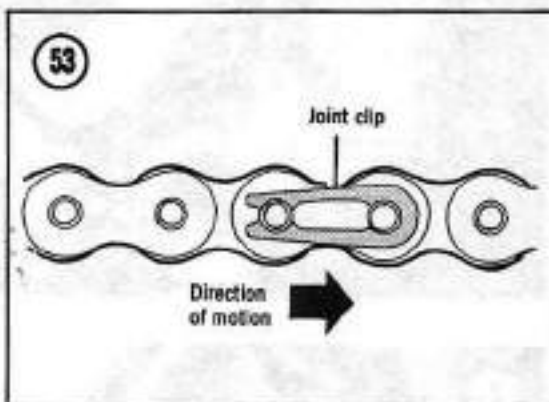

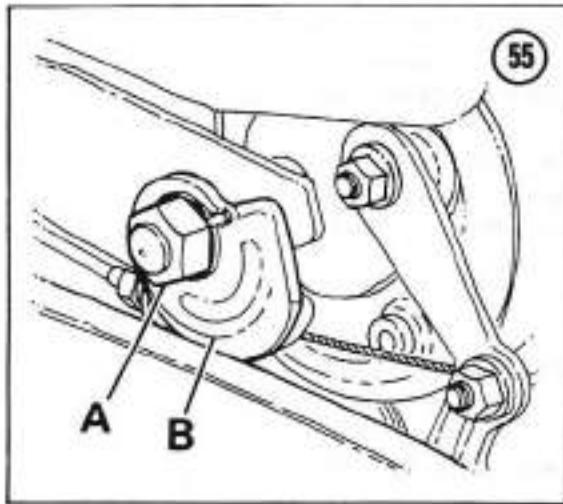

3. Check to see that the wheel is aligned within the center of the chain stays.
4. Rotate the wheel to make sure the tension in the chain is constant.
5. Tighten the rear axle locknuts securely.
6. Check the rear brake operation as it may have to be adjusted. Refer to *Rear Brake Adjustment* in Chapter Nine.

Crank Axle

In order to gain access for removal of the crank axle it is necessary to remove the engine and split the crankcase.

Refer to *Crankcase Disassembly/Assembly* in Chapter Five.

CHAPTER SEVEN

FUEL AND EXHAUST SYSTEMS

The fuel system consists of the fuel tank, fuel shutoff valve, fuel filter, Dell'Orto carburetor and an air filter.

The exhaust system consists of an exhaust pipe and muffler that can be taken apart for carbon removal.

This chapter includes service procedures for both fuel and exhaust systems.

Service procedures for the different engines are virtually identical. Where there are differences, they are identified.

CARBURETOR

The carburetor is a single barrel, side draft type that can be taken apart for service (Figure 1, on the following page).

Refer to Table 1 for carburetor model number and jet size for your particular model.

Removal/Installation

1. Remove the air filter body from the carburetor by loosening the clamp screw (Figure 2) and pulling the air filter straight off of the carburetor.

2. Remove the 2 screws securing the carburetor top. The carburetor top, spring, throttle valve and choke release pawl will stay with the throttle cable (Figure 3).

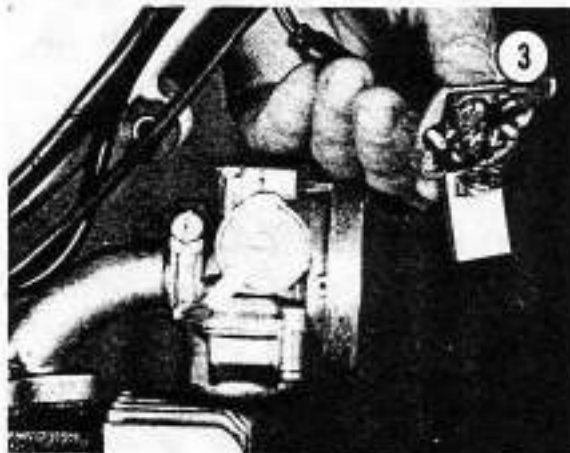
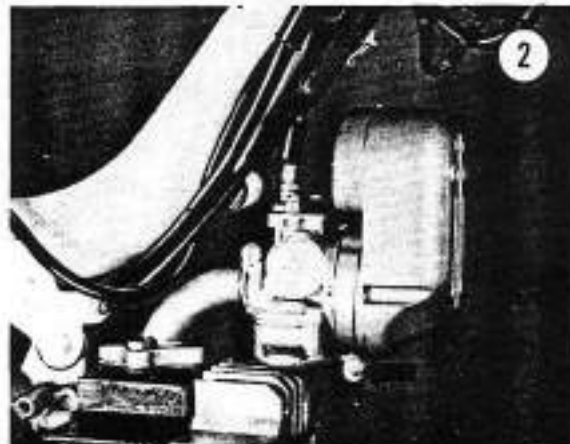

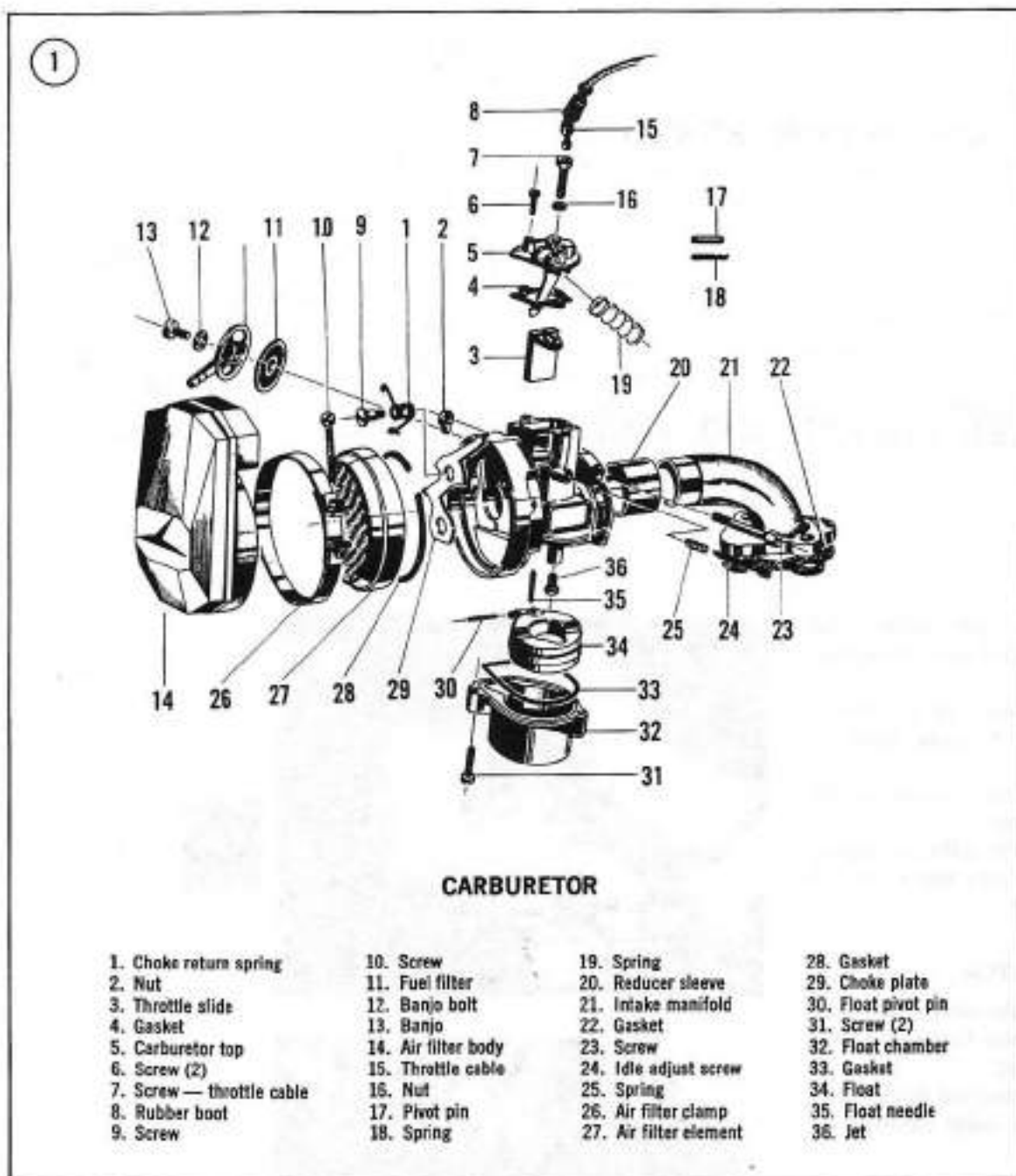
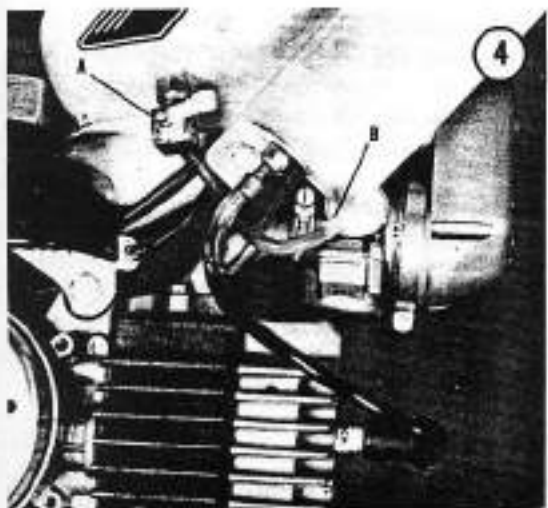

Table 1 CARBURETOR MODEL NUMBERS

MODEL	Engine Version		
	17-20 mph	25 mph	30 mph
Carburetor	Dell'Orto	Dell'Orto	Dell'Orto
Model Number	SHA 14/12	SHA 14/12	SHA 14/12
Jet Size	48	50	50 or 52



3. Turn the fuel shutoff valve (A, Figure 4) to the off position and remove the fuel line (B) from the carburetor banjo fitting.

4. Loosen the clamp screw (A, Figure 3) securing the carburetor to the intake manifold. Pull carburetor straight forward and off of the manifold.

5. Install by reversing the removal steps.

Disassembly/Assembly

1. Unhook the slide from the throttle cable. Remove the slide, spring, carburetor top and choke release pawl from the throttle cable.

2. Remove the banjo bolt and washer (Figure 5) securing the banjo and fuel filter (Figure 6) and remove them.

3. Remove the 2 screws (Figure 7) securing the float chamber and remove it.

4. Unscrew and remove the jet (Figure 8).

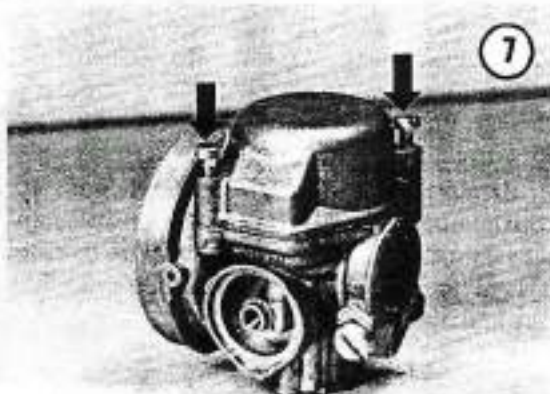
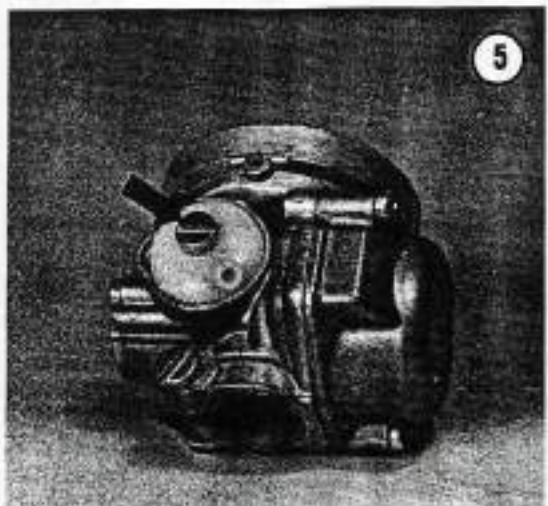

7

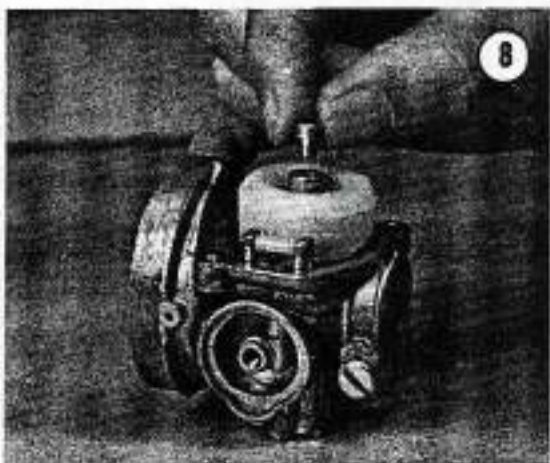
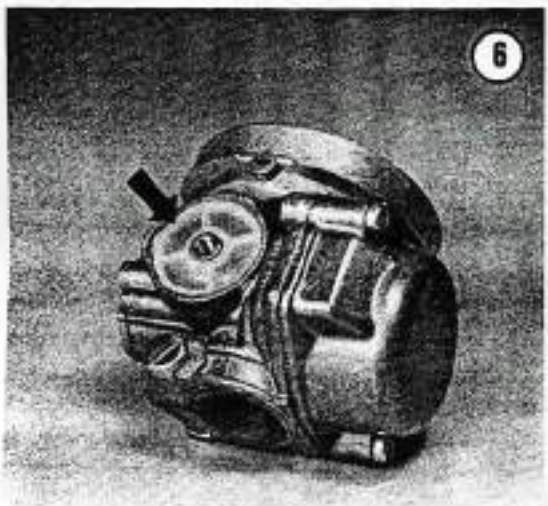

5. Slide out the float pivot pin (Figure 9) and remove the float and float needle (Figure 10).
6. Assemble by reversing the disassembly steps. Use new gaskets.
7. When assembling the banjo fitting, do not tighten it completely until the carburetor has been installed on the engine. Position the banjo so it aligns with the fuel line. The fuel line should have no sharp bends that would allow it to "kink" and shut off fuel flow. Now securely tighten the banjo fitting.

Overhaul

It is difficult to determine exactly how often a carburetor should be overhauled. As a rule of thumb it is a good idea to overhaul the carburetor every time the engine is decarbonized. If your moped is used in dusty conditions the overhaul should be performed more often.

Cleaning

1. Clean all parts except the float, fuel filter, banjo and gaskets in a good grade of carburetor cleaner. Follow the manufacturer's instructions for correct soak time (usually about ½ hour).
2. Remove parts from cleaner and blow dry with compressed air. Blow out the jet with compressed air. Do not use a piece of wire to clean it as minor gouges in the jet can alter the flow rate and upset the fuel/air ratio.

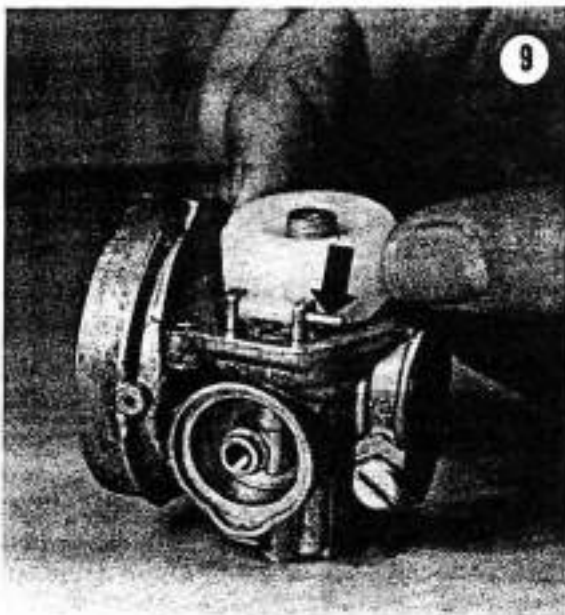

3. Shake the float to see if there is gasoline inside. If there is, the float has a leak and must be replaced.

FUEL FILTER

The fuel filter can be removed without removing the carburetor. Unscrew the banjo and remove the banjo and filter. Clean out the filter with a medium soft toothbrush and blow out with compressed air. If filter is cracked or broken it should be replaced.

FUEL SHUTOFF VALVE

1. Turn the shutoff valve to the OFF position (Figure 11).

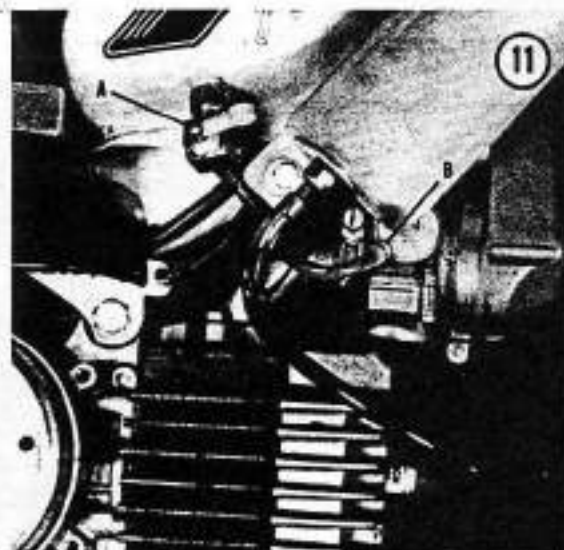
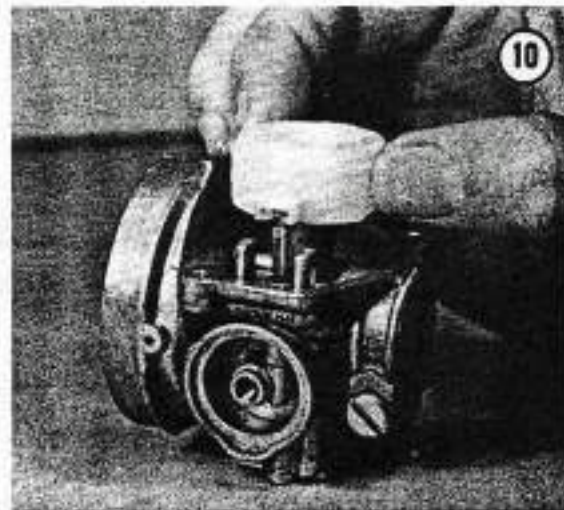

2. Remove the flexible fuel line from the carburetor (Figure 11) and place the loose end into a clean, sealable metal container. This fuel can be reused if it is kept clean. Do not drain it into your gasoline can as this fuel already has engine oil added to it.

3. Open the fuel valve to the RESERVE position and remove the fuel fill cap. This will allow air to enter the tank and speed up the flow of fuel. Drain the tank completely.

4. Remove the fuel shutoff valve by unscrewing the fitting from the tank (Figure 12).

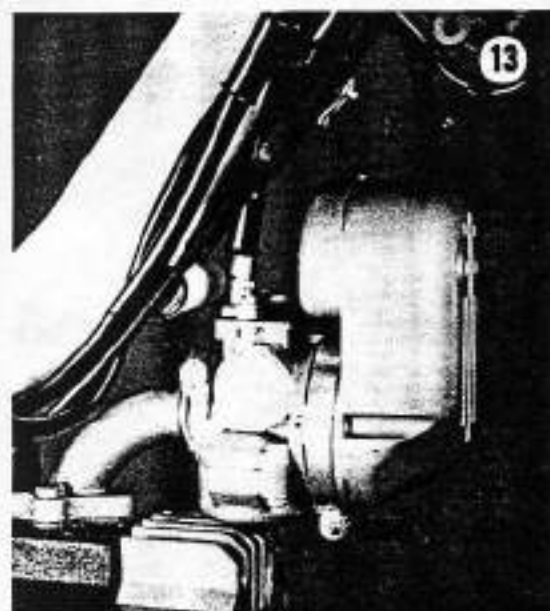

5. After removing the valve, insert a corner of a clean shop rag into the opening in the tank to stop the dribbling of fuel onto the frame.

6. Clean out the filter with a medium soft toothbrush and blow out with compressed air. Replace if any part is defective.

7. Install by reversing the removal steps, do not forget the gasket.

AIR FILTER

CAUTION

Do not ride the moped without the air filter installed. Damage may occur to the carburetor and/or the engine if any small objects are drawn into the carburetor throat.

1. Remove the air filter from the carburetor by loosening the clamp screw (Figure 13) and pulling the air filter straight off of the carburetor.

2. Pull the air filter element from the throat of the carburetor (Figure 14).

3. Wash out the element in cleaning solvent and dry thoroughly with compressed air or tap vigorously into a dry clean cloth until all of the cleaning solvent is out. After it is thoroughly dry, apply some light weight oil to it. Do not saturate it as it will restrict the air flow and pull the excess oil into the carburetor.

4. Wash the inside and outside of the air filter body in cleaning solvent and thoroughly dry with a clean lint-free cloth.

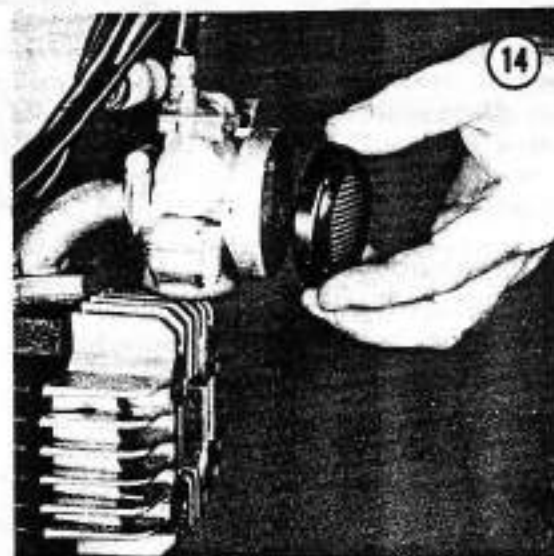

5. Install by reversing the removal steps. Install the air filter element with the angled side out (Figure 15).

FUEL TANK

Prior to removal of the fuel tank it is necessary to drain it completely.

NOTE: There are two different tank configurations used on the Garrelli. The Eureka, Sport and Gran Sport shown in the following procedure, have their tanks mounted at an angle as they are used with the step-through type frame. On the Super Sport XL, the tank is mounted similar to a motorcycle in a horizontal format. There are only slight differences in removal and installation as noted in the following procedure.

1. Turn the fuel shutoff valve (Figure 16) to the OFF position and remove the fuel line from the carburetor.
2. Place the loose end of the fuel line into a metal can that can be sealed.

NOTE: Do not put it into your gasoline can as this fuel already has oil added.

3. Remove the fuel tank fill cap, turn the shut-off valve to the RESERVE position and drain the fuel.
4. After draining is completed, turn the fuel shutoff valve to the OFF position. Replace the fuel fill cap and seal the metal container.

WARNING

Do not smoke or have any open flame in the area while performing this procedure. Also have a fire extinguisher suitable for gasoline fires within reach.

5. Reinstall the fuel line on the carburetor and remove it from the fuel shutoff valve (Figure 16).
6. Remove the oil injector line from the fitting (Figure 17) on top of the tank. Do not remove the fitting.
7. On Eureka, Gran Sport and Sport models remove the 2 bolts, washers and nuts (Figure 18) securing the tank to the frame and remove the tank.

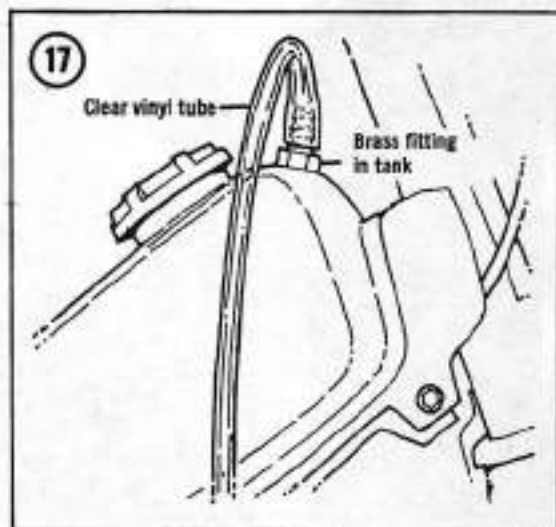
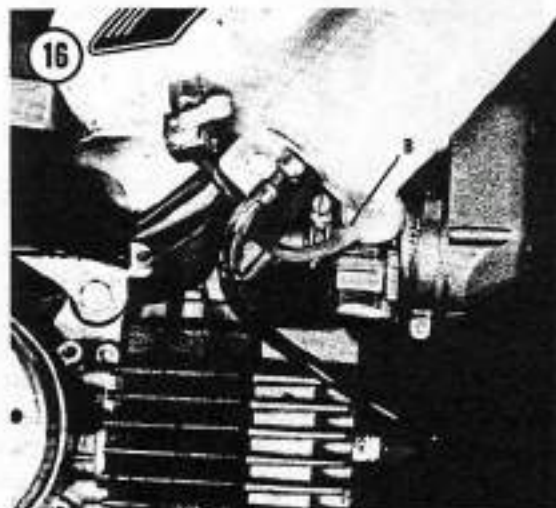
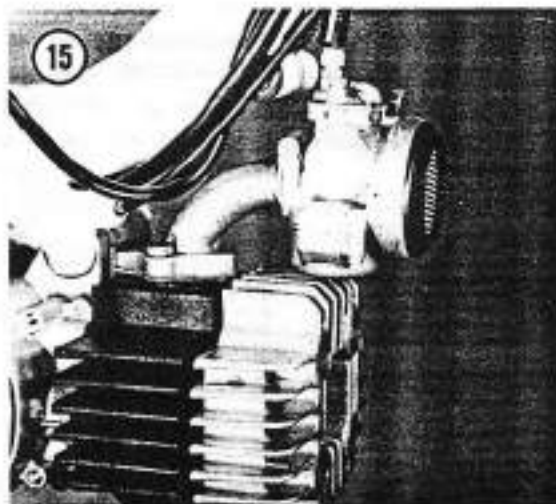

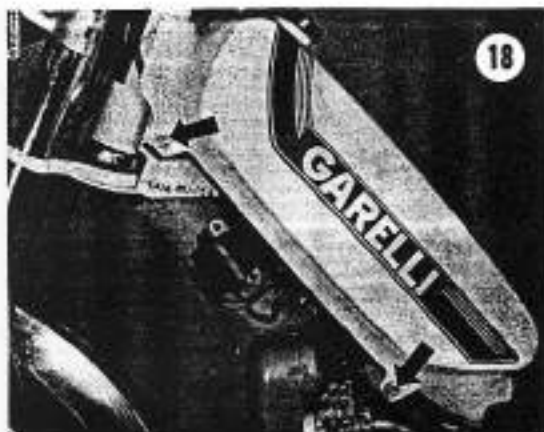

8. On Gran Sport Twin models remove the upper bolt, washer and nut (Figure 19). Slide the tank forward and upward to clear the tab holding the lower part of the tank to the frame.

9. On Super Sport XL models it is necessary to remove the seat first. Remove the 2 bolts, washers, lockwashers and nuts at the rear of the seat. Pull the seat to the rear and remove.

10. Remove the bolt, washer, spacer, bushing, lockwasher and nut at the rear of the tank. Pull the tank to the rear and remove.

11. After removal, pour a small quantity of clean gasoline into the empty tank and slosh it around. Remove the fill cap, then pour it out. If any sediment comes out, continue this procedure with fresh gasoline until it drains out clean.

12. If there is a leak in the tank, take it to your dealer and have the problem corrected. Do not attempt this yourself.



EXHAUST SYSTEM

The muffler is a very important part of the 2-cycle engine in regard to operating performance. It must be cleaned periodically to remove the normal carbon buildup. This is described under *Muffler Decarbonizing* in Chapter Three.

7

Muffler/Removal/Installation

1. On Eureka, Gran Sport, Sport and Super Sport XL models remove the 2 bolts securing the exhaust pipe to the cylinder (Figure 20) and remove the 2 bolts securing the muffler at the rear (Figure 21).

2. On Gran Sport Twin model remove the large nut (Figure 22) securing the exhaust pipe to the cylinder. Remove the 2 bolts securing the muffler at the rear (Figure 23) and remove the muffler and exhaust pipe.

3. Separate the exhaust pipe and the muffler by loosening the screws on the clamp (Figure 24) and pulling exhaust pipe out from muffler.

4. Install by reversing the removal steps, using a new gasket between the exhaust pipe and the cylinder.

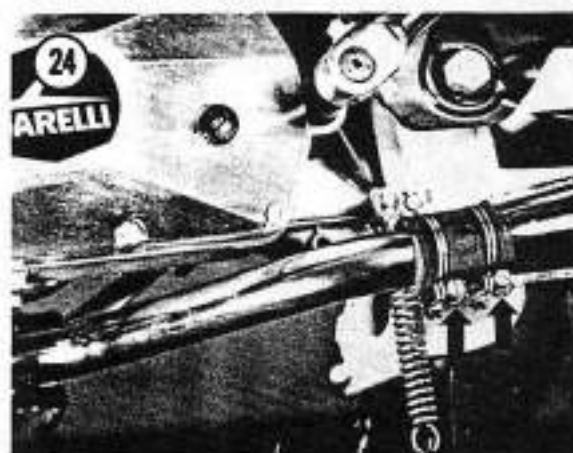
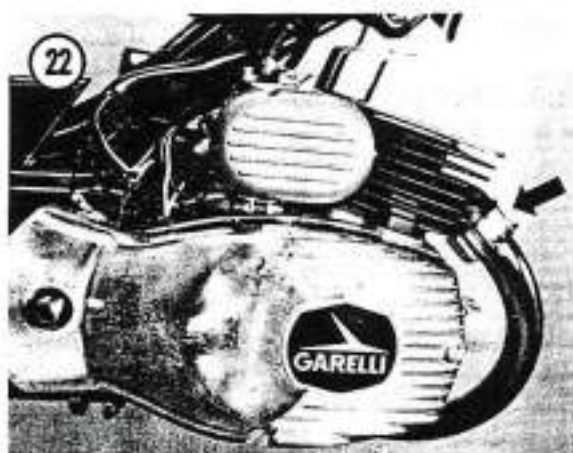
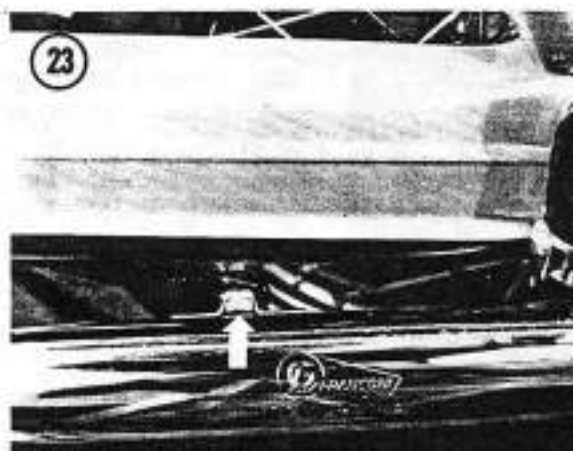

CHAPTER EIGHT

ELECTRICAL SYSTEM

This chapter discusses the operating principles and maintenance of the ignition and lighting systems.

Service procedures for these systems for the different engines are virtually the same. Where there are differences, they are identified.

MAGNETO

The engine-mounted magneto generates electricity for the lights and spark plug. It works similar to a generator or alternator on an automobile, but is more compact and is attached directly to the engine (Figure 1).

The stator is stationary and consists of two coils of specially wound wire attached to the engine crankcase. The rotor has built-in permanent magnets which rotate with the engine crankshaft. As the magnets move past the stationary coils they induce a voltage within these coils which powers the lights, horn and spark plug.

The ignition breaker points, in the magneto, are used to regulate current flow from the ignition coil to the spark plug, at just the right time, when the piston reaches firing position. (This is magneto ignition timing. Timing procedures are covered in Chapter Three, under *Tune-up*.) When the breaker points are closed the current is grounded, thus no current flows to the spark

plug. When they open, the current that has built up in the coil is no longer grounded and is allowed to flow from the coil directly to the spark plug, bypassing the breaker points. This sudden burst of current jumps the spark plug gap creating the spark for igniting the fuel mixture. To prevent the points from arcing when they open, a condenser is placed in the circuit.

Figure 2 illustrates the breaker points and condenser in the ignition circuit leading to the spark plug. There is a wiring diagram at the end of this chapter.

Removal (Eureka, Sport, Gran Sport, Super Sport XL)

1. Remove the rubber mat and the 4 bolts securing the engine fairing (Figure 3) and remove it.
2. Remove the 4 screws securing the right-hand engine cover (Figure 4) and remove it.
3. Remove the nut and washer securing the rotor with an impact driver (Figure 5).
4. Remove the rotor with a flywheel puller (Figure 6). Screw the outer body of the puller into the rotor until it stops (Figure 7). Hold the outer body stationary with a wrench and turn the inner bolt with a socket until the rotor disengages from the crankshaft. Remove the rotor.

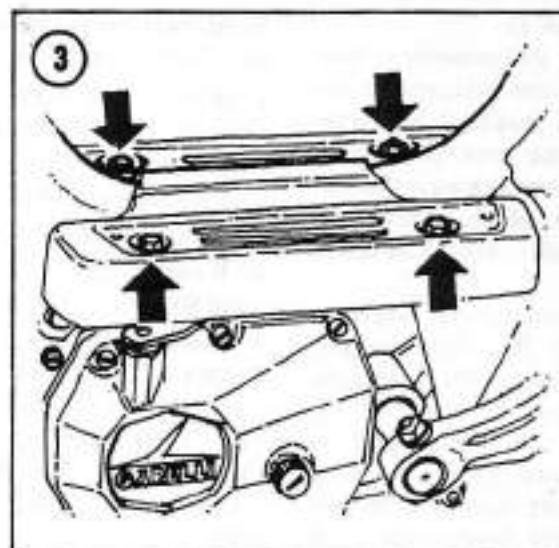
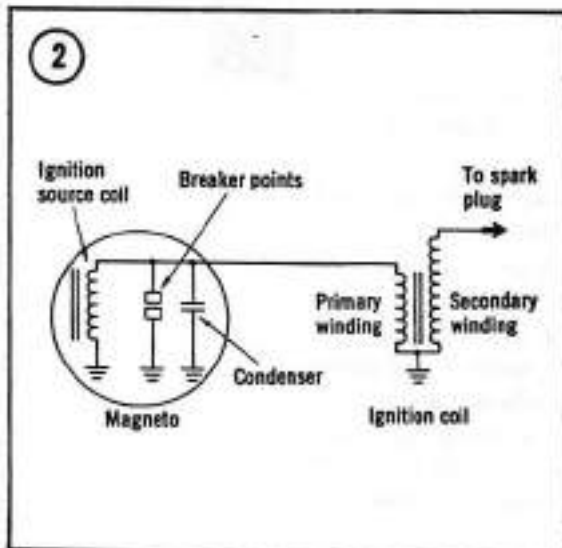
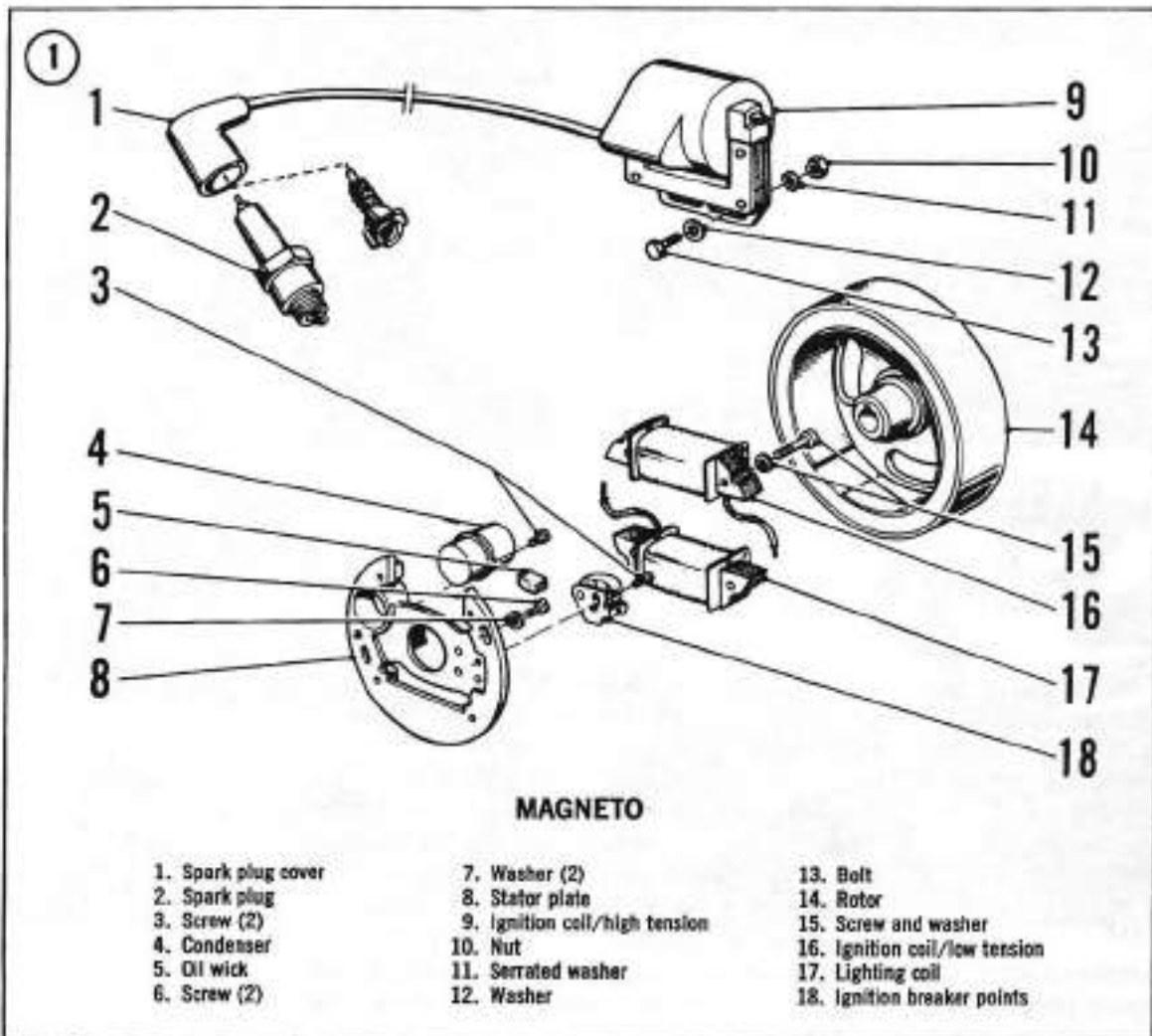

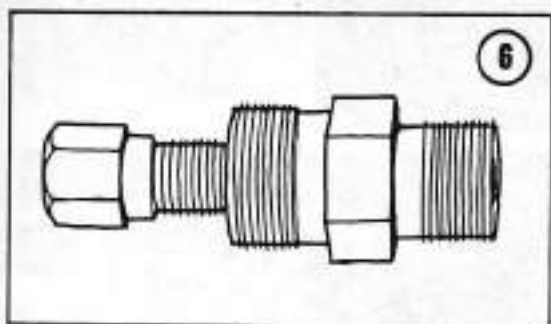
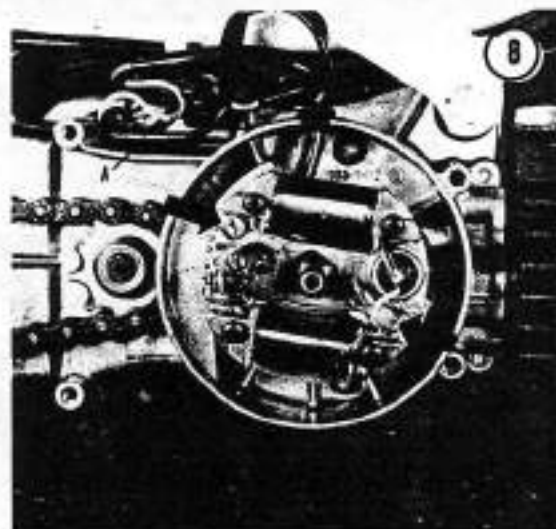
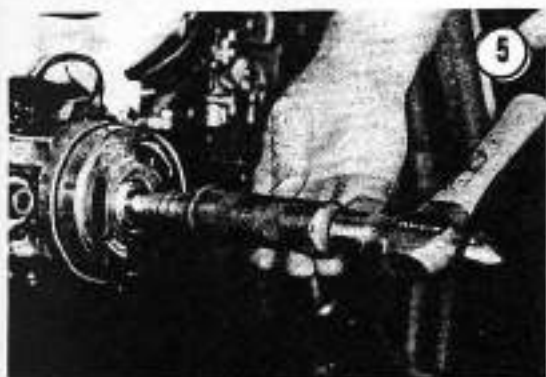
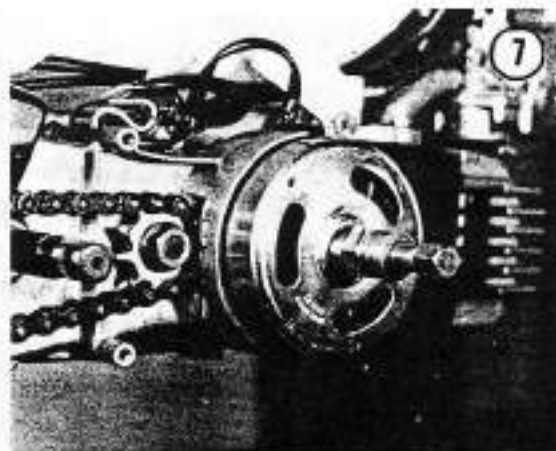
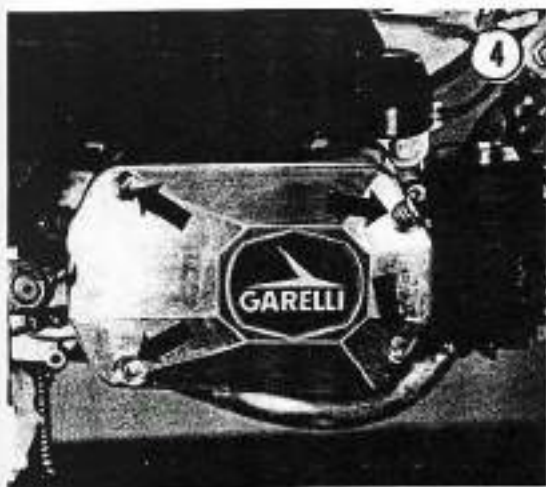

5. Remove the 2 machine screws and lockwashers securing the stator to the crankcase (Figure 8).

6. Remove all 3 magneto electrical wires from the terminal connector (A) located above the magneto (Figure 8).

7. Slide the rubber grommet that surrounds the electrical wires where they enter the magneto out from magneto housing, along with the wires, and remove the stator.

8. Install by reversing the removal steps. Be sure that grommet is securely in place and that none of the wires are pinched between the stator and the magneto housing. Use an impact driver for the final tightening of the rotor nut. If a torque wrench is used, torque nut to 12 ft.-lbs. (16.3 N•m).

9. Be sure to reconnect the electrical wires in the same location in the terminal connector. Refer to the electrical diagram at the end of this chapter if you have any questions.

Removal (Gran Sport Twin)

1. Remove the 2 screws (Figure 9) securing the step plate and remove it.

2. Remove the screw (Figure 9) securing the right-hand engine fairing and remove it.

3. Remove the right-hand crank arm as described under *Crank Arm Removal/Installation* in Chapter Six.

4. Remove the 3 screws (Figure 10) securing the engine/magneto cover and remove it.

5. Remove the nut and washer (Figure 11) securing the rotor with an impact driver.

6. Remove the rotor with a flywheel puller (Figure 6). Screw the outer body of the puller into the rotor until it stops (Figure 12). Hold the outer body stationary with a wrench and turn the inner bolt with a socket until the rotor disengages from the crankshaft. Remove the rotor.

7. Remove all 3 magneto electrical wires from the terminal block located above the magneto (Figure 13).

8. Remove the 3 screws securing the stator to the crankcase (Figure 14).

9. Slide the rubber grommet that surrounds the electrical wires where they enter the magneto out from the magneto housing, along with the wires, and remove the stator.

10. Remove the adaptor ring (Figure 15).

11. Install by reversing the removal steps. Be sure to install the adaptor ring as shown in Figure 15. Be sure that the grommet is securely in place and that none of the wires are pinched between the stator and the magneto housing.

12. Install the nut, securing the rotor, with an impact driver or a torque wrench. Torque the nut to 12 ft.-lb (16.3 N•m).

NOTE: To prevent the rotor from rotating while tightening the nut, use a strap wrench (Figure 16).

13. Be sure to reconnect the electrical wires in the same location in the terminal block. Refer to the electrical diagram, at the end of this chapter, if you have any questions.

Breaker Points

1. Remove the magneto rotor as described under *Magneto Removal/Installation* in this chapter.

2. Remove nut (A) attaching electrical terminal and screw (B) securing point assembly to stator (Figure 17).

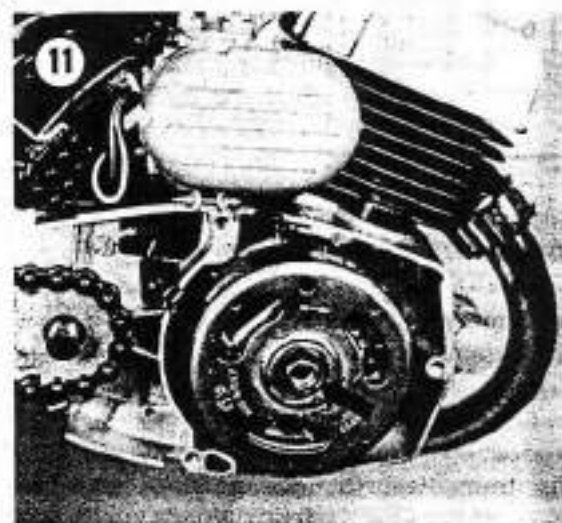
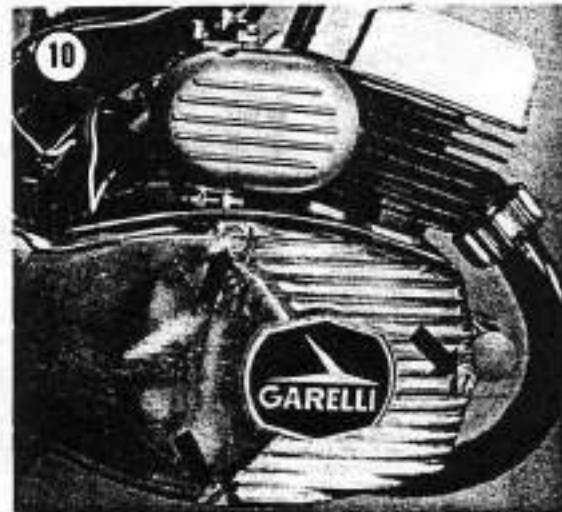
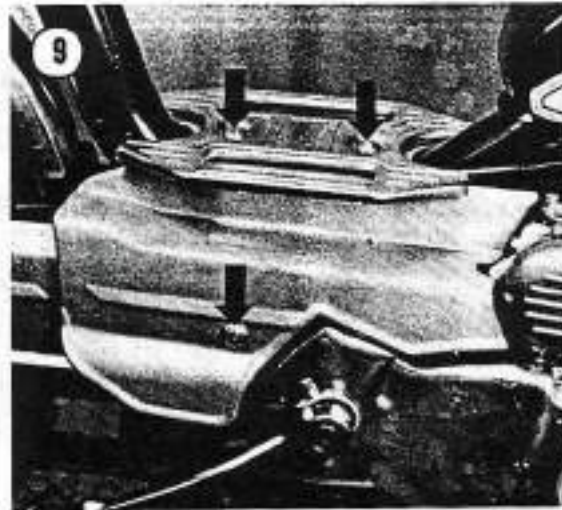

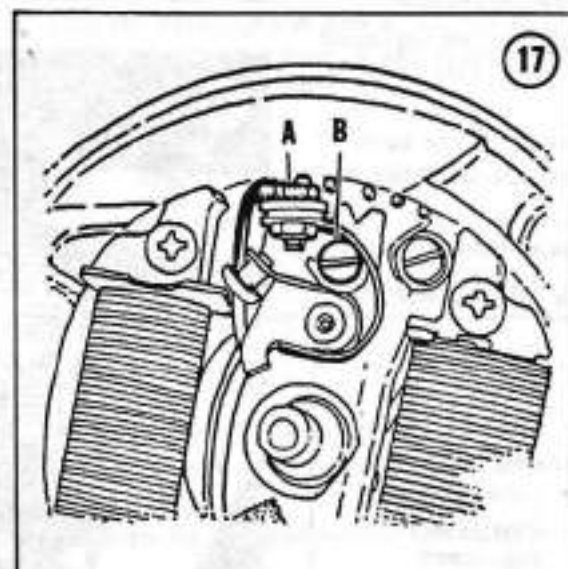
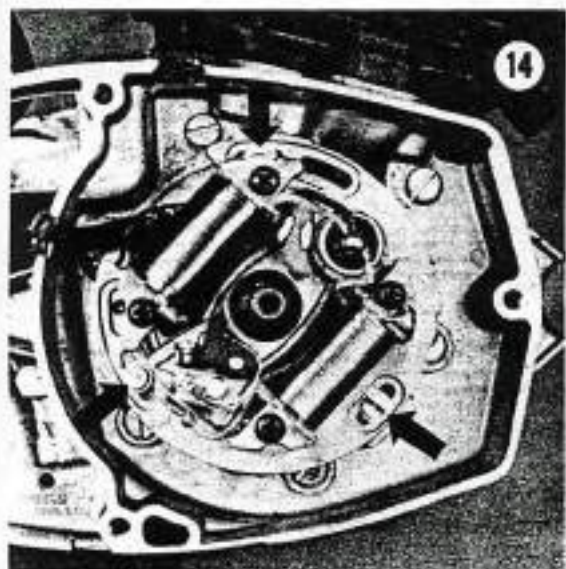
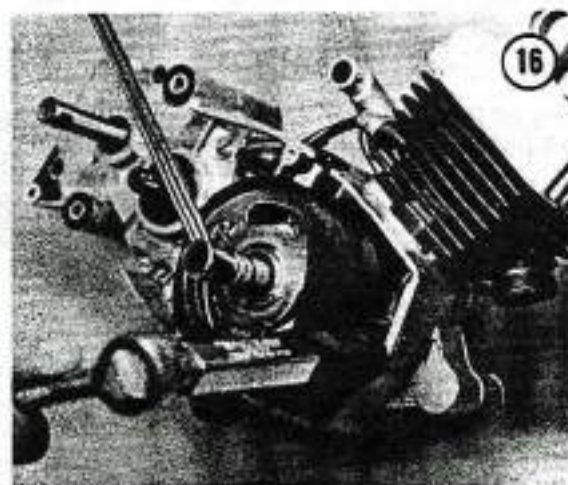
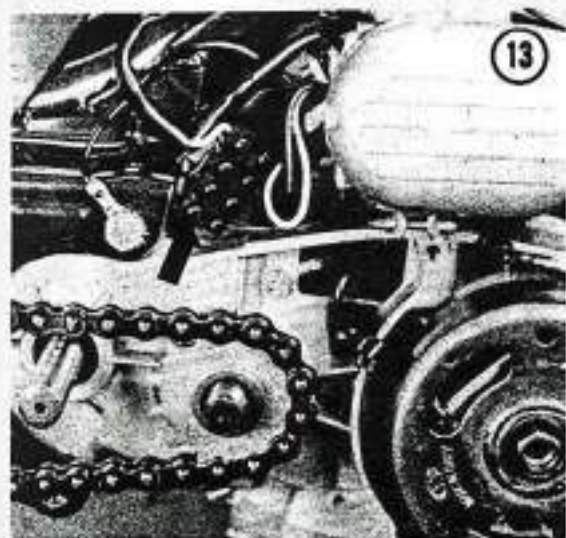
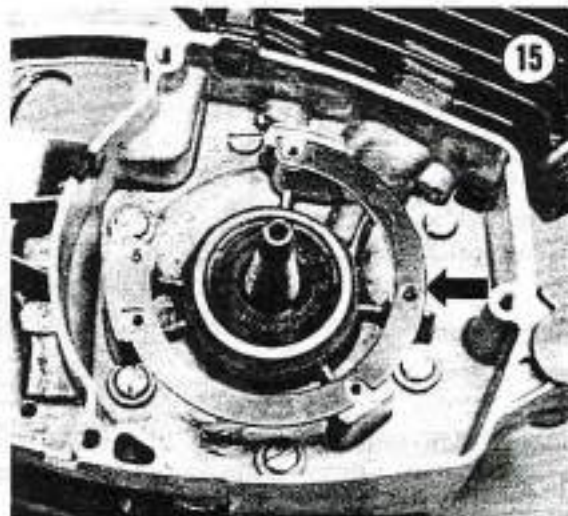
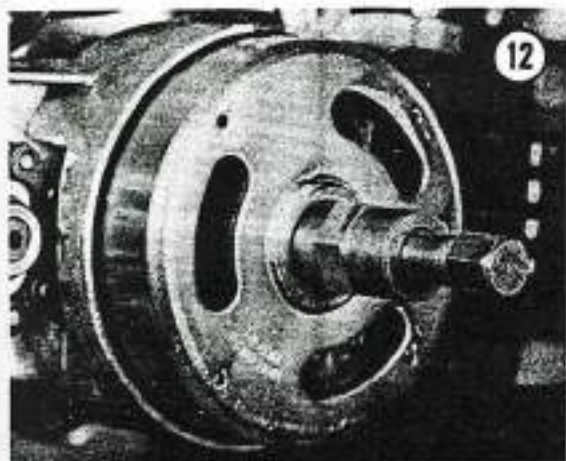

3. Install by reversing the removal steps and adjust timing as described under *Magneto Ignition Timing* in Chapter Three.

ELECTRICAL SYSTEM

Power for the lighting system is provided by the magneto. The electrical system consists of:

- a. Headlight
- b. Taillight/brakelight combination
- c. Speedometer illumination light
- d. Horn
- e. Switches for the ignition, lights, brakes and horn.

Table 1 lists the bulb specifications for replacement.

HEADLIGHT

The headlight unit consists of a lamp housing, chrome trim bezel, lens with reflector, bulb holder and 20 watt bulb. The headlight switch is located on the left side of the handlebar.

Replacement

1. Remove screw at bottom of chrome trim bezel (**Figure 18**).
2. Pull out on the bottom of the lens and chrome trim bezel and pull up and away from the base.
3. Disconnect the electrical wire from the terminal on the back of the sealed beam bulb.
4. Remove retaining clips that secure the sealed beam into the chrome trim ring with a screwdriver.
5. Check the rubber grommet, at the back of the base, for cracks or deterioration. Replace if necessary.
6. Install by reversing the removal steps.

Table 1 LIGHT BULB REPLACEMENT

Light	Type
Headlight	Sealed beam 6 Volt, 20 Watt
Taillight/brakelight	6 Volt, 5 and 8 Watt double element
Speedometer	6 Volt, 0.6 Watt single element

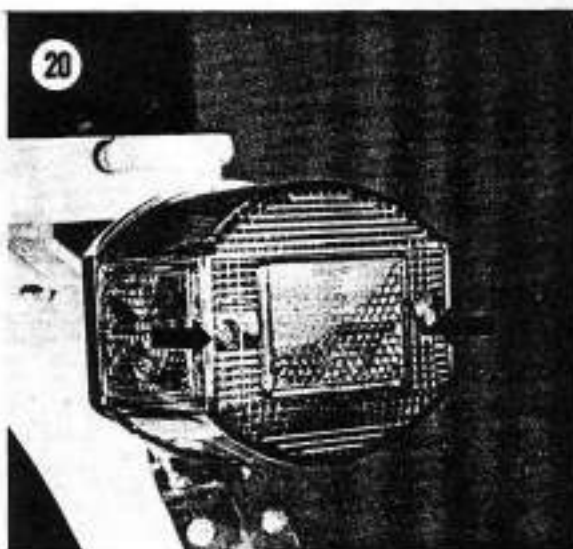
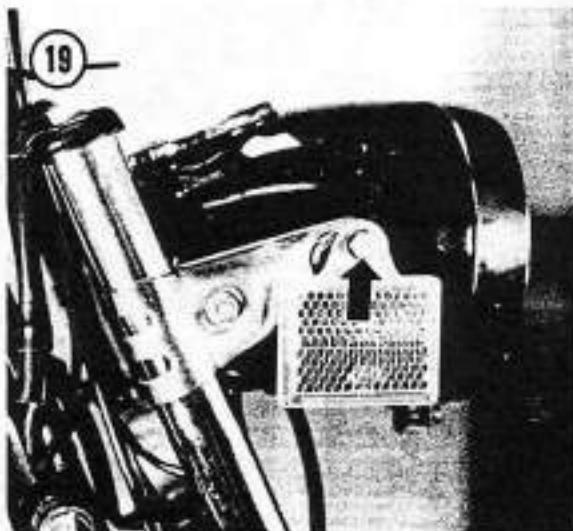
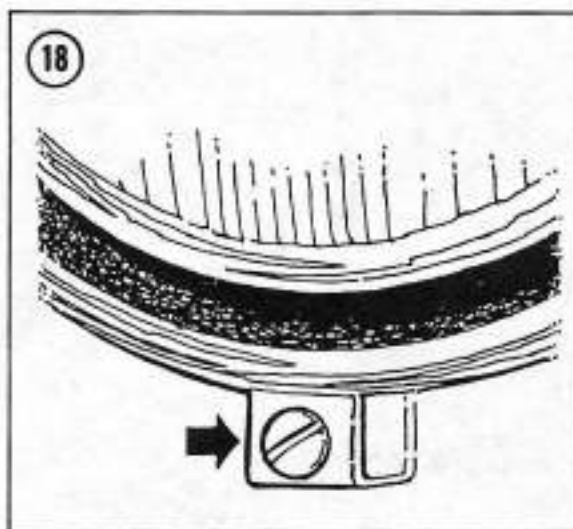

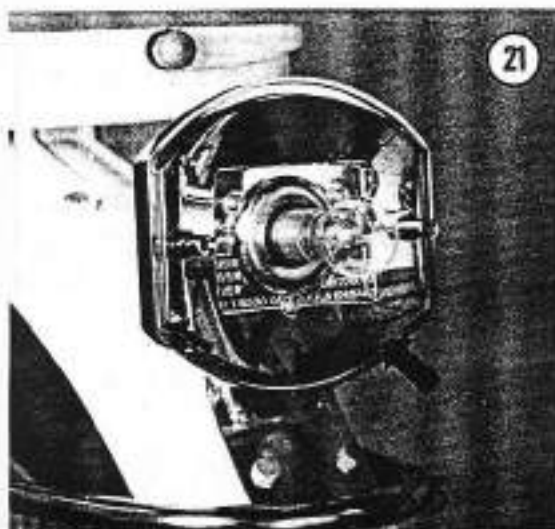

Adjustment

This procedure is best accomplished at night or at dusk.

1. On a garage door or flat wall, stick a 12 inch piece of masking tape, horizontally, 19¼ inches up from the ground.
2. Place the moped so the front of the headlight is 33 feet back from this surface and pointed directly at it.
3. Sit on the moped with the centerstand raised.
4. Turn the headlight on. It should hit directly on this line. If not, loosen the adjusting bolts (Figure 19), one on each side of the headlight, and rotate the light assembly with your hands until it is correct.
5. Tighten the adjusting bolts securely.

TAILLIGHT/BRAKELIGHT

1. Remove the 2 lens attachment screws (Figure 20), and remove the lens.
2. Push the bulb in slightly and twist it counterclockwise and remove.
3. If necessary clean the 2 contact points, at the base of the bulb socket, with a small piece of 180 grit sandpaper wrapped over the end of a pencil.
4. Wash out the inside and outside of the lens with a mild detergent and wipe dry.
5. Wipe off reflective base surrounding the bulb with a soft cloth (Figure 21).

CAUTION

This part is chrome-plated plastic — do not use an abrasive to clean it, as it will scratch and dull the surface, thus reducing the effectiveness of the taillight and brakelight.

6. Check the sealing gasket and rubber grommet for cracks or deterioration. Replace if necessary.
7. Install by reversing the removal steps; be sure to install the gasket.

SPEEDOMETER ILLUMINATION LIGHT

The bulb illuminates the speedometer for night use. It is turned on with headlight. The speedometer is built into the headlight housing on models except the Super Sport XL.

Replacement (Eureka, Sport, Gran Sport, Gran Sport Twin)

1. Remove screw at bottom of headlight trim bezel (Figure 18).
2. Pull out on the bottom of the lens and chrome trim bezel and pull up and away from the base.
3. Pull the speedometer bulb support down and out of the bulb housing. Remove the bulb and replace.

Replacement (Super Sport XL)

1. Pull the bulb support down and out of the bulb housing in the base of the speedometer housing. Remove bulb and replace.

BRAKELIGHT SWITCH

The switches are located at the base of each brake hand grip on the handlebar. The brake light will go on when either the front or rear or both brakes are applied.

Removal/Installation

1. Pull back rubber boot (Figure 22).
2. Pull electrical connectors off of switch terminals.
3. Unscrew locknut and switch from hand lever base.

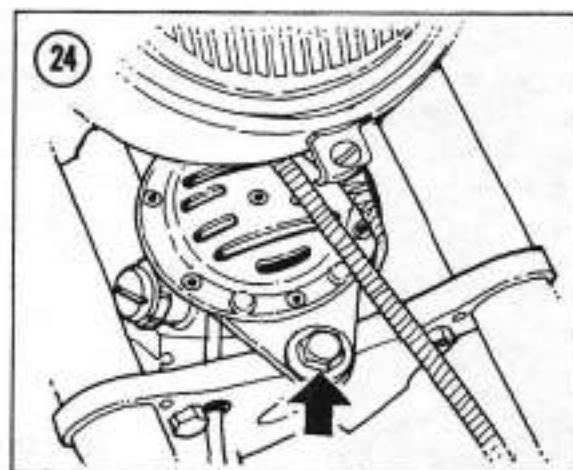
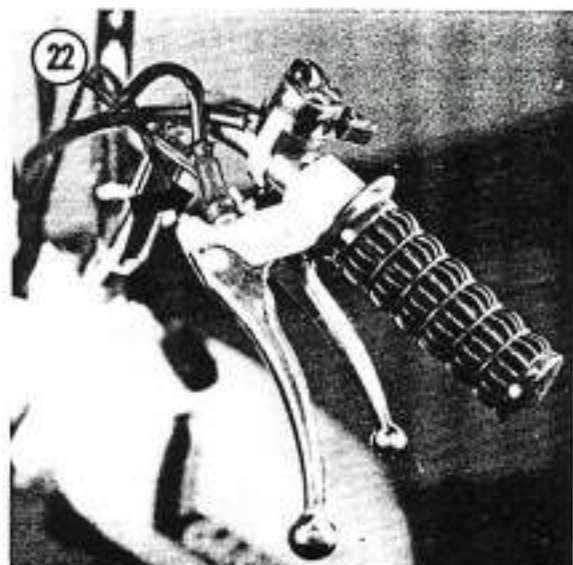

HEADLIGHT, HORN AND CUTOFF SWITCHES

Remove the screw on the underside of the clamp securing the clamp to the handlebar (**Figure 23**). Remove switch and electrical wires. Prior to removal make a drawing of the routing of the wires through the frame. It is very easy to forget how it was once they have been removed. Replace them exactly as they were. Do not allow any electrical wires to come in contact with the engine as the heat will melt the insulation and eventually short out the wire.

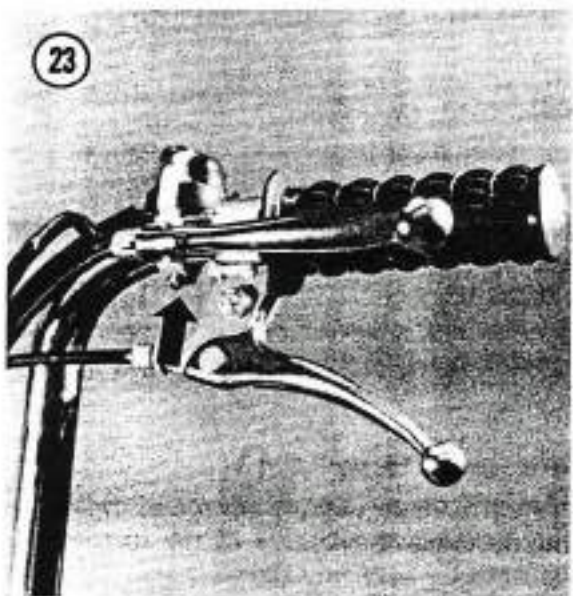

4. Install by reversing the removal steps. Make sure the switch is screwed in all the way before tightening the locknut. If rubber boot is deteriorated it should be replaced at this time.

HORN

The horn operates on electricity supplied by the magneto and operated by the horn button located by the left hand grip.

Removal/Installation

Remove the 2 electrical connections from the terminals on the horn. Remove bolt and nut securing horn bracket to the frame (**Figure 24**) and remove. Install by reversing the removal steps and make sure the electrical connections do not touch any metal parts.

WIRING DIAGRAM

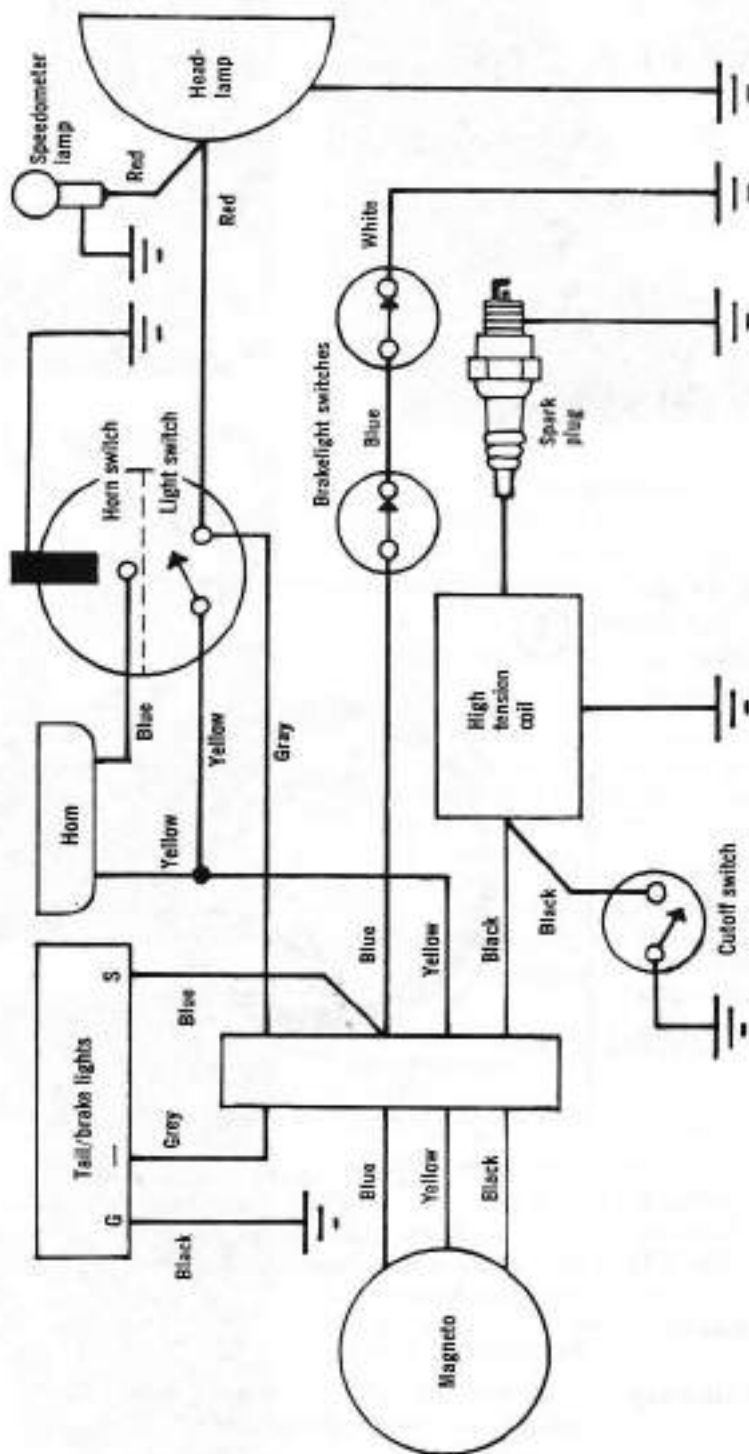

CHAPTER NINE

BRAKES

Figure 1 illustrates the major parts of the brakes. Squeezing the brake lever, on the handlebar, rotates the cam which in turn forces the brake shoes out into contact with the brake drum.

BRAKE CABLE

Brake cable adjustment should be checked periodically as the cables stretch out with use and increase brake lever free play. Free play is the distance the brake lever travels between the released position and the point when the brake shoes come in contact with the drum. This should be kept to a minimum.

Adjustment

1. At the brake plate, turn the adjustment nut (A) at the end of the outer cable housing, toward the end of the housing (**Figure 2**). This should take out the necessary slack.
2. If proper adjustment cannot be achieved by this method, loosen the cable clamp bolt (B, **Figure 2**) and turn the adjusting nut (A) *in* away from the end of the outer cable housing.
3. Pull on the end of the cable until it is taut. Tighten the cable clamp bolt (B). If necessary repeat Step 1.

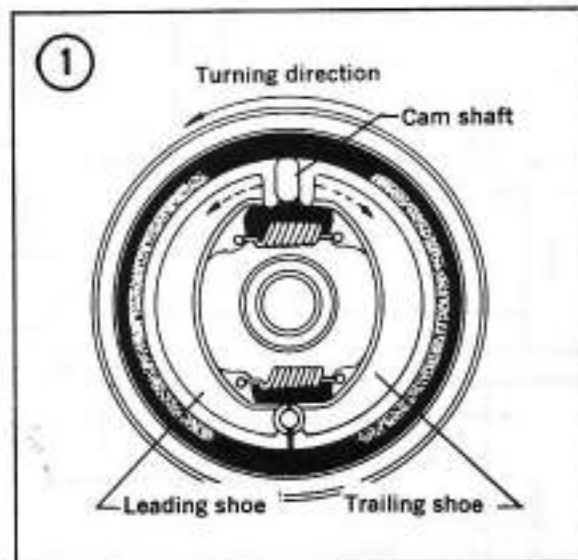

NOTE: *If proper adjustment cannot be achieved by using both of these methods the cable will have to be replaced. See Brake Cable Removal/Installation in this chapter.*

Removal/Installation

In time the cable will stretch to the point where it is no longer useful and will have to be replaced.

1. Loosen the cable clamp bolt (B) at the brake plate (**Figure 2**).

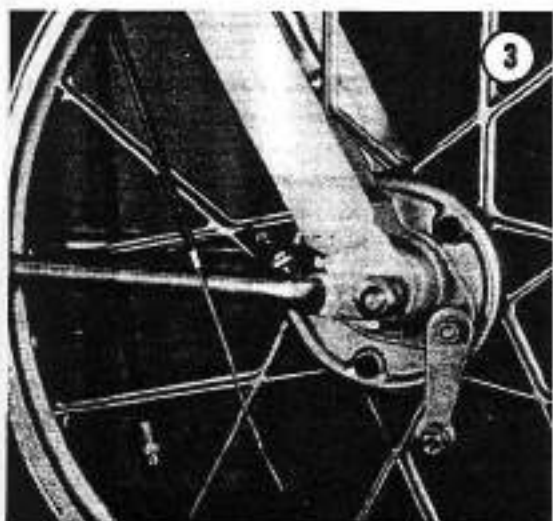
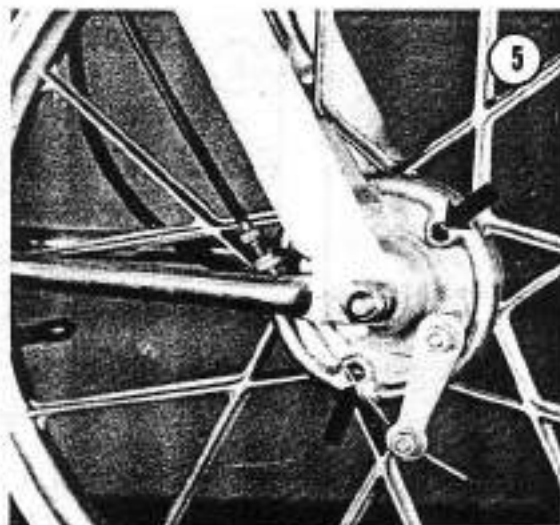
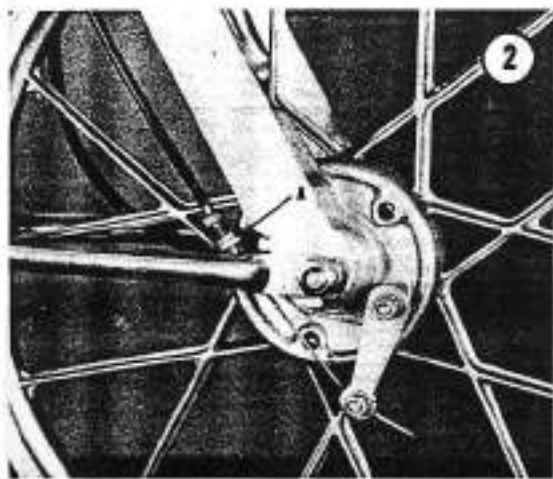

2. Slip the end of the cable out of the fitting on the brakeplate (Figure 3).

3. Pull the hand lever all the way back to the grip; remove the cable nipple holder (Figure 4) and remove the cable from the lever.

4. Remove the cable from the frame.

NOTE: Prior to removal of the cable, make a drawing of the routing of the cable through the frame. It is very easy to forget how it was once it has been removed. Replace it exactly as it was, avoiding any sharp turns.

5. Install by reversing the removal steps, adjusting the brakes as described under *Brake Adjustment* in this chapter.



BRAKE LINING

Inspection

Both the front and rear wheel hubs have inspection holes (Figure 5) to check the brake lining thickness without removing and disassembling the hubs.

The brake lining should be replaced if worn within $5/64$ in. (2mm) of the metal shoe table (Figure 6). This is measured at the thinnest part.

Removal/Installation

1. Remove front and/or rear wheel as described under *Front or Rear Wheel Removal/Installation* in Chapter Ten.

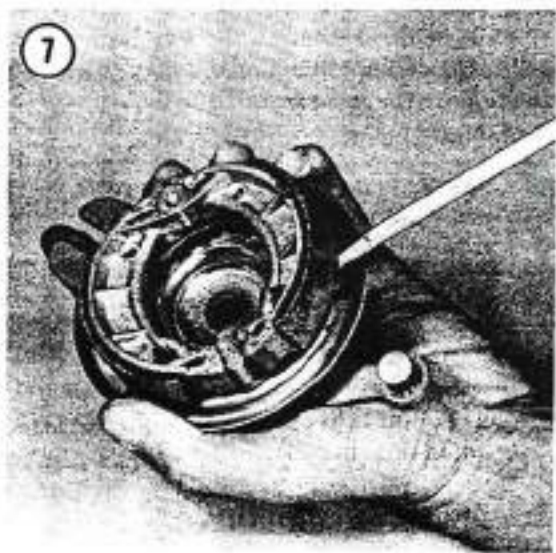
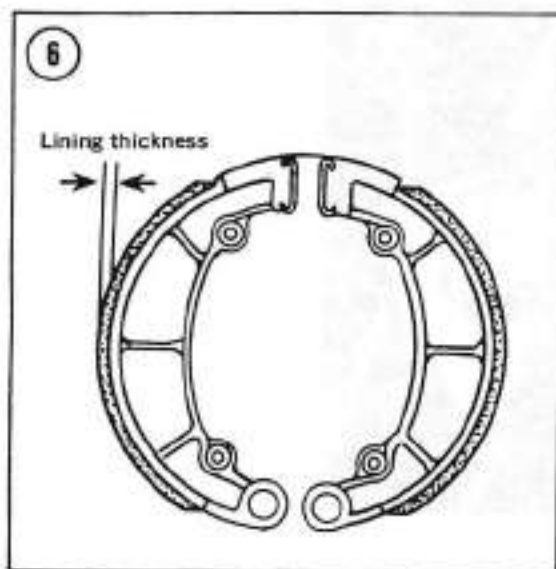

2. Remove the thin nut and spacer and remove brake assembly from hub.
3. Remove the brake shoe assembly, including the return springs from the brake plate. Pry each shoe from the brake plate (Figure 7) using a screwdriver or similar tool.
4. Inspect the linings for any traces of oil or grease. If they are contaminated they should be replaced. Dirt embedded in the lining may be removed with a wire brush.
5. The linings should be replaced if worn within $\frac{1}{8}$ in. (2.0mm) of the metal shoe table (Figure 6). Measure it as the thinnest part.

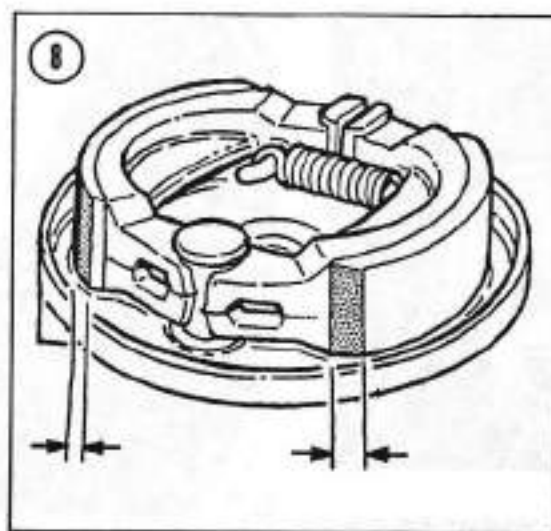

6. Check the cam and pivot pin for wear and corrosion. Clean off any corrosion with fine emery cloth. Check that the cam rotates freely. If cam or pivot pin is worn the brake plate should be replaced.
7. Inspect the brake return springs for wear. If they are stretched they will not fully retract the brake shoes and they will drag and wear out prematurely. Replace if necessary.
8. Install by reversing removal steps. Apply a light coat of grease to the cam and pivot pin. Avoid getting any grease on the brake plate where the linings may come in contact with it. Hold the shoes in a V-formation with the springs attached and snap them in place on the brake plate.

NOTE: If new linings are being installed, file off the leading edge of each shoe a little (Figure 8) so that the brakes will not grab when applied.

BRAKE DRUM

Removal/Installation and Inspection

1. Remove front and/or rear wheel as described under *Front or Rear Wheel Removal/Installation* in Chapter Ten.
2. Pull the brake assembly out of hub.
3. Inspect the drum for deep grooves, roughness or scoring. Replace if necessary.
4. Install by reversing the removal steps.

CHAPTER TEN

SUSPENSION AND FRAME

This chapter contains service and repair of wheels, tires, steering and suspension.

Service procedures for the different models are virtually identical. Where there are differences, they are identified.

FRONT WHEEL

Removal/Installation

1. Unscrew the knurled nut holding the speedometer cable onto the drive unit (Figure 1) and remove.
2. Disconnect the brake cable by loosening the cable clamp bolt at the brake plate (Figure 2). Slip the end of the cable out of the fitting (A) on the brake plate (Figure 3).
3. Remove the axle locknuts (B, Figure 3), remove the fender brackets and remove the wheel.
4. Install by reversing the removal steps. Position the speedometer drive unit to align with the cable before tightening the axle locknuts.

CAUTION

Be sure to insert the slot in the brake plate onto the tab on the right-hand fork (Figure 4). This is necessary for proper brake operation.

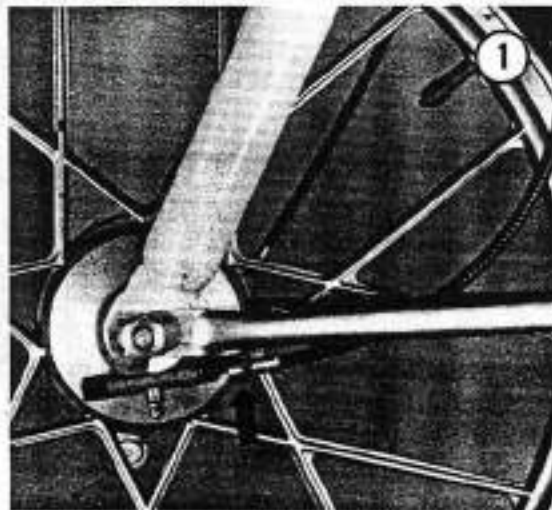

REAR WHEEL

Removal/Installation

1. Disconnect the rear brake cable by loosening the cable clamp bolt (A) at the brake plate (Figure 5). Slip the end of the cable out of the fitting on the brake plate.
2. Remove the axle locknuts (B, Figure 5).
3. Remove the drive chain by removing the master link (Figure 6) as follows: Pry the outer clip off with a thin bladed screwdriver. Remove the outside plate and push the inside plate,

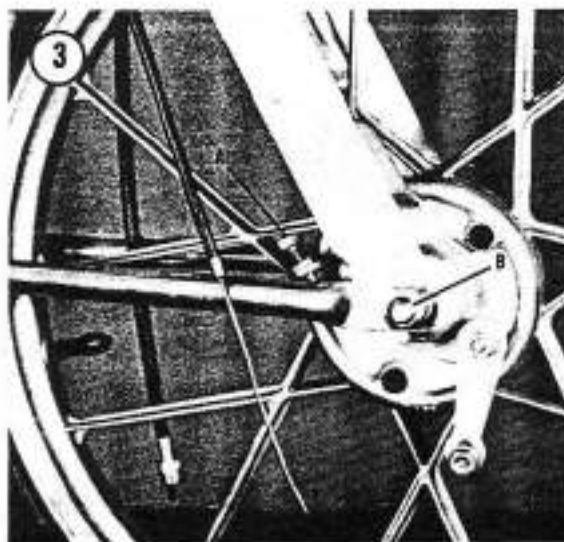
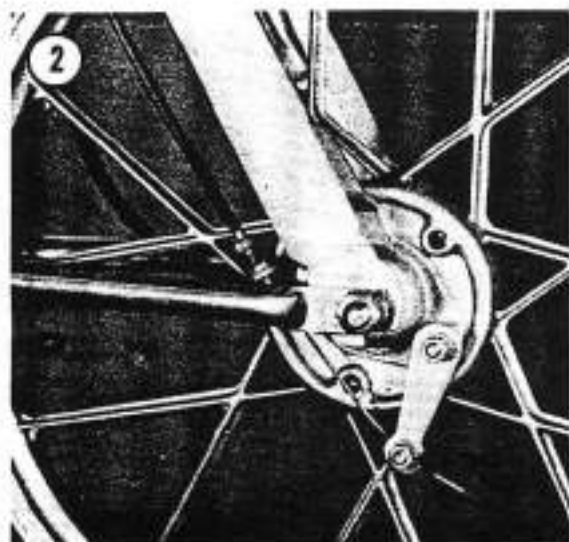

complete with pins, out through the back of the chain and remove the chain.

4. Pull the wheel rearward and remove. Support moped by placing the rear swing arm on a wooden box or blocks of wood.

5. Install by reversing the removal steps.

CAUTION

Be sure to insert slot in brake plate onto the stud on the rear swing arm (Figure 7). This is necessary for proper brake operation.

6. Make sure the master link clip is installed with the opening facing in the opposite direction of chain travel (Figure 8). Incorrect installation will result in the loss of the clip and may result in chain breakage.

7. After the wheel and chain have been reinstalled it is necessary to adjust the chain tension as described under *Drive Chain Adjustment* in Chapter Six. It is also necessary to adjust the rear brakes as described under *Brake Adjustment* in Chapter Nine.

FRONT AND REAR WHEEL HUBS

Refer to Figure 9 for front wheel hub and Figure 10 and rear wheel hub.

The front and rear hubs are basically the same except for the brakes and the addition of the sprocket on the rear. The disassembly and assembly are the same.

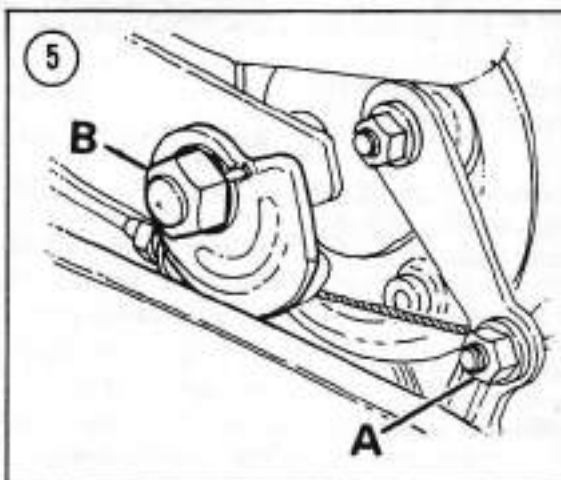
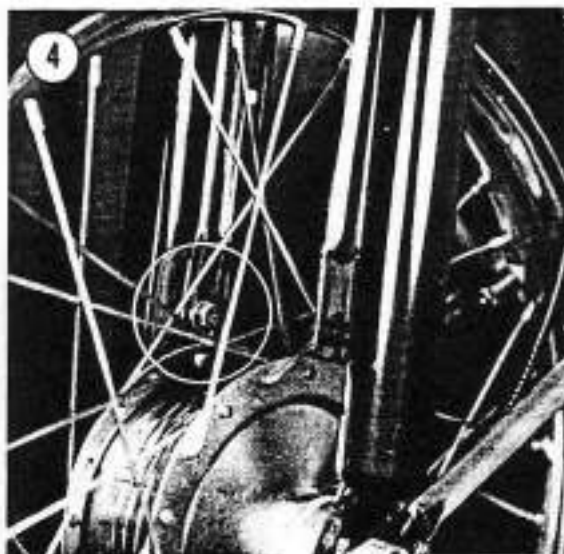

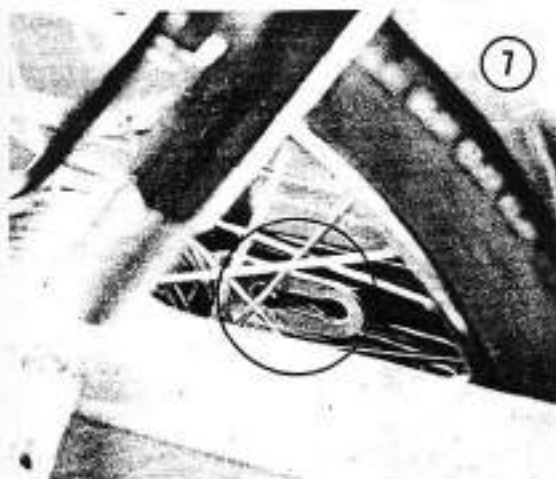
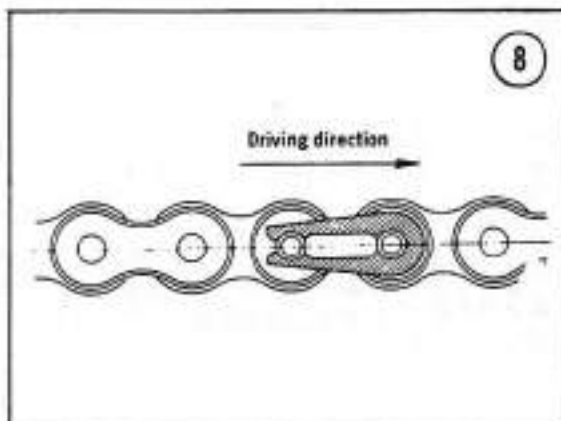
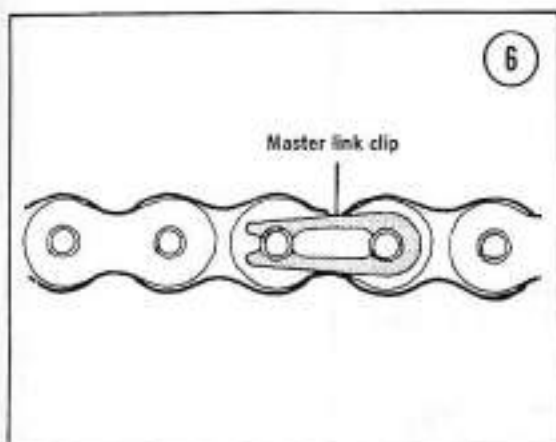

Removal/Installation

1. Remove the wheel as described under *Front or Rear Wheel Removal/Installation* in this chapter.
2. Remove the thin nut and spacer and remove the brake plate assembly. Remove the nut securing the speedometer drive on the front wheel and the nut securing the sprocket on the rear wheel.
3. Place the wheel horizontally in a vise with the brake drum facing up. Securely grip the lockwasher and cone in the vise jaws.
4. Hold the adjusting cone, with a cone wrench, and loosen the locknut and remove both locknut and adjusting cone.
5. Remove the vise and slide the axle out of the hub assembly.
6. Leave the remaining cone and locknut on the axle unless one of these parts is damaged. If

it is necessary to remove either of these, measure the distance from the end of the axle to the top of cone (Figure 11) so that the cone can be reinstalled in the same position.

7. To remove balls, pry out the dust cover with a wide bladed screwdriver. Remove balls and count them, 10 on each side, so that the same number are installed. Turn the hub over and repeat the steps on the other side.

Inspection

1. Clean all parts thoroughly in solvent.
2. Check cone and hub cups for pitting and excessive wear. If the cups are damaged they should be removed as follows: Insert a hardwood stick in from the opposite side and with a hammer carefully tap the cup out from the inside. Tap all the way around the cup so that neither the cup nor the hub will be damaged. Install the cup by placing it into the hub and tap it gently and squarely in with a block of hardwood and a hammer. Make sure it seats completely.
3. Check the balls for pitting or wear. Replace the complete set of balls if any are defective.
4. Check the retaining washers for distortion or cracks; replace if necessary.
5. Check the axle for damaged threads of bending; replace if necessary.
6. Check adjusting cone and locknut threads for damage; replace if necessary.

Installation

1. Pack the ball cups with wheel bearing grease and replace the correct number of balls. There

9

FRONT WHEEL HUB

- | | |
|----------------------------|-----------------------------|
| 1. Nut (2) | 12. Nut |
| 2. Washer (2) | 13. Adjusting cone (2) |
| 3. Nut (2) | 14. Brake cam |
| 4. Spacer | 15. Dust cover (2) |
| 5. Brake plate | 16. Balls (20) |
| 6. Adjusting screw and nut | 17. Brake shoe assembly |
| 7. Brake lever | 18. Brake return spring (2) |
| 8. Nut | 19. Cage (2) |
| 9. Washer (2) | 20. Spindle/axle |
| 10. Bolt, nut, washer | 21. Nut |
| 11. Washer | 22. Washer |
| | 23. Speedometer drive unit |

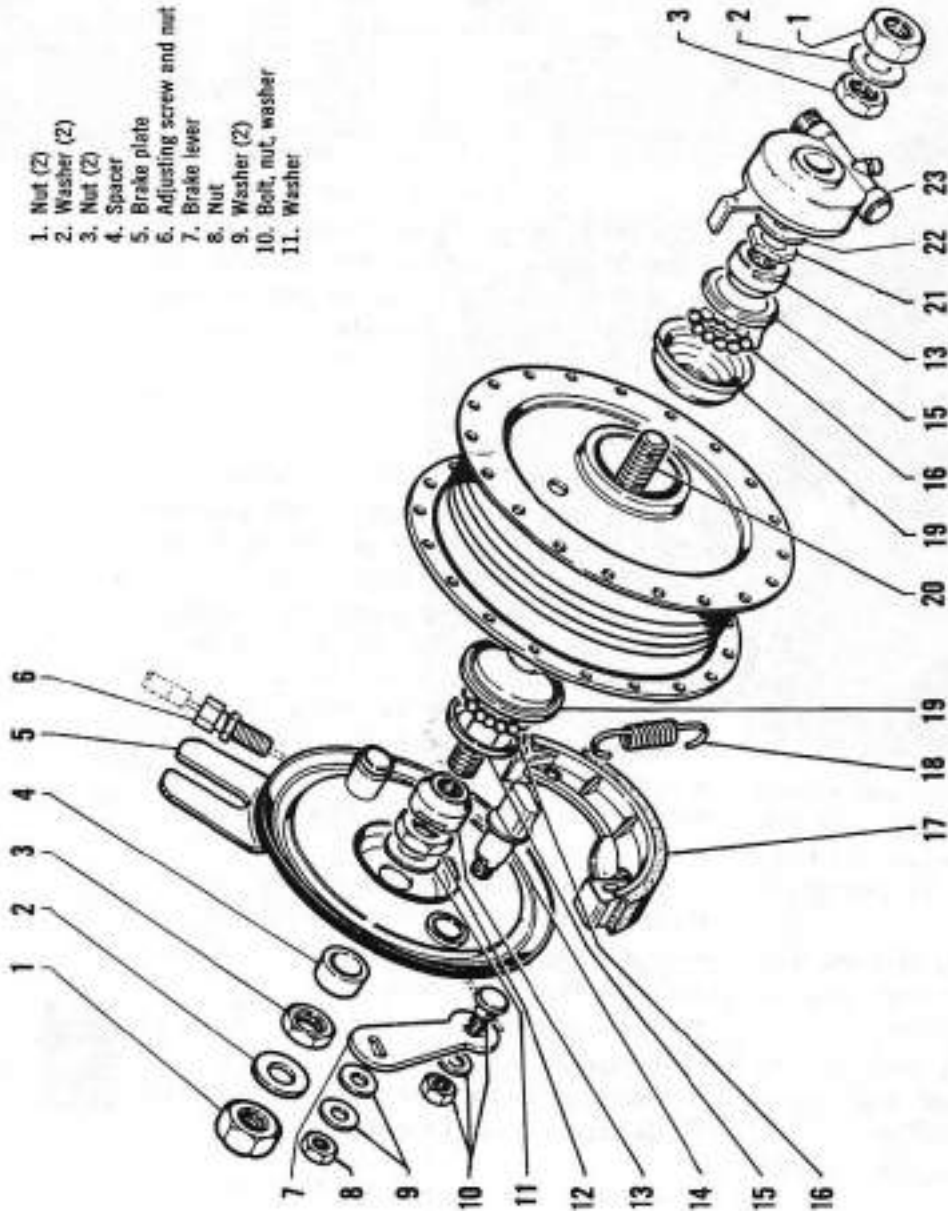

REAR WHEEL HUB

1. Nut (2)
2. Washer (2)
3. Adjusting cam (2)
4. Bolt and nut (4 each)
5. Locking plate
6. Spacer
7. Sprocket
8. Thin nut (2)
9. Washer (2)
10. Adjusting cone (2)
11. Dust cover (2)
12. Balls (20)
13. Cage (2)
14. Spindle/axle
15. Brake shoe cam
16. Bolt, washer, nut
17. Washer
18. Nut
19. Brake lever
20. Nut
21. Brake return spring (2)
22. Brake shoe assembly
23. Adjusting screw and nut
24. Brake plate
25. Spacer

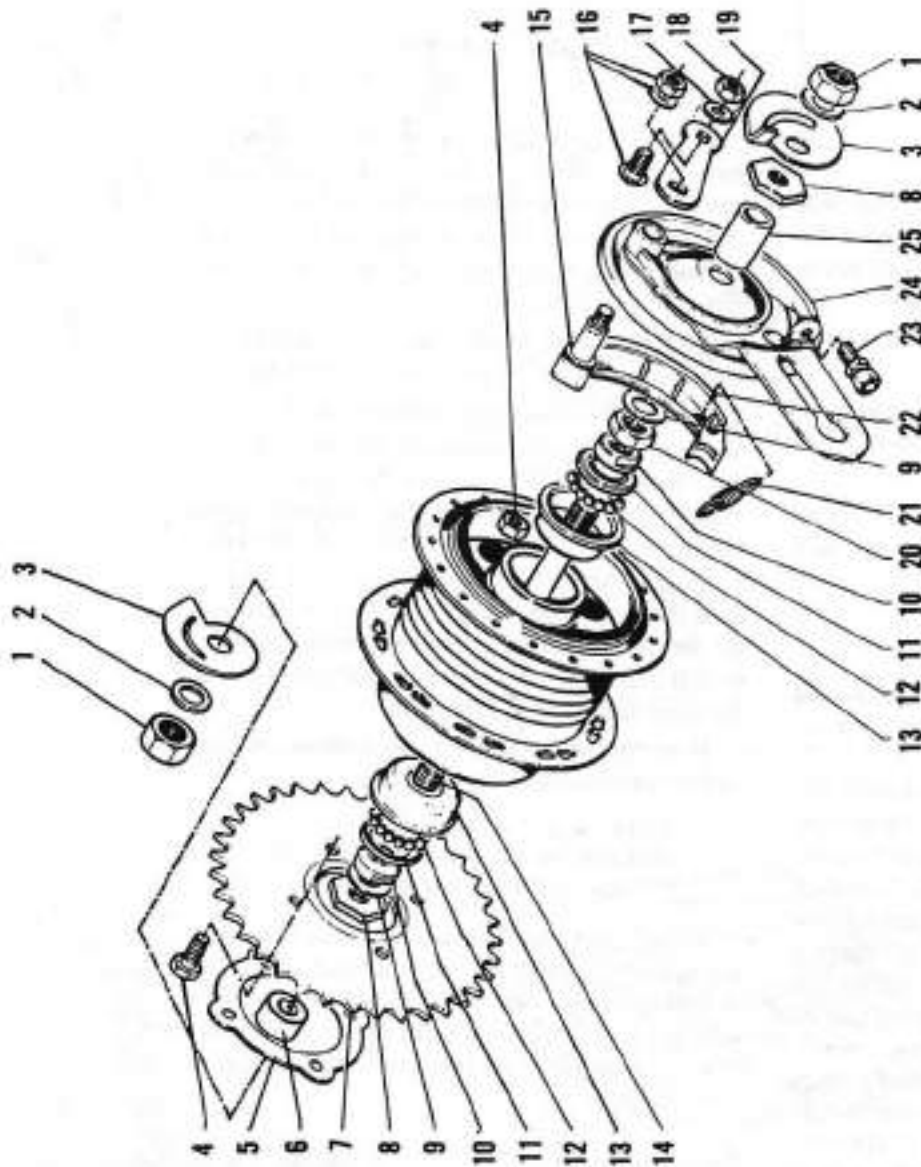

10

10

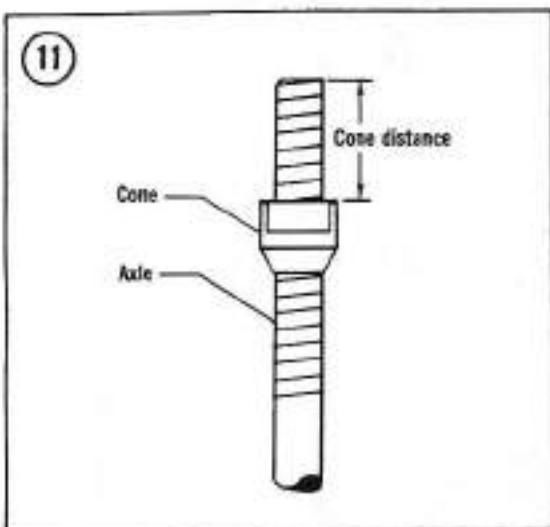

are 10 on each side of both wheels. There will be a little space left over as the balls are not very snug against each other. Replace the dust cover by tapping into place with a plastic mallet.

2. Insert the axle and install the remaining cone and locknut.
3. Tighten cone until all axle end play has been removed but the axle will still rotate freely.
4. Tighten the locknut and recheck.
5. Install the wheel as described under *Front or Rear Wheel Removal/Installation* in this chapter.

SPOKES

The spokes support the weight of the moped and the rider; they also transmit accelerating and braking forces.

Spokes should be checked periodically for looseness or bending. Check spokes for proper tension. The "tuning fork" method for checking tension is simple and works well. Tap each spoke with a spoke wrench or screwdriver shank. A taut spoke will emit a clear, ringing tone; a loose spoke will sound flat. All spokes in a correctly tightened wheel will emit tones of similar pitch, but not necessarily the same tone.

Bent, stripped or otherwise damaged spokes should be replaced as soon as they are detected. Unscrew the nipple from the spoke at the rim, then push the nipple far enough into the rim to free the end of the spoke, taking care not to push the spoke all the way in. Remove the

defective spoke from the hub, then use it to match a new one of the same length. Install by reversing the removal steps. Check new spoke periodically, as it will stretch and must be re-tightened several times until it takes its final set.

Spokes tend to loosen as the moped is used. Retighten each spoke one turn, beginning with those on one side of the hub, then those on the other side. Tighten the spokes on a new moped after the first 50 miles of operation, then at 50 mile intervals until they no longer loosen.

TIRES AND TUBES

Tire Removal

Refer to **Figure 12** for this procedure. Always leave the locknuts on the axle to protect the threads during tire removal/installation.

1. Unscrew the valve core from the valve stem with a special tool (**Figure 13**) and deflate the tire.
2. Press the entire bead on both sides of the tire away from the rim and into the center of rim.
3. Lubricate the beads with soapy water.
4. Insert a tire iron under the top bead next to the valve. Force the head on the opposite side of the tire into the center of the rim and pry the bead over the rim with the tire iron (**Figure 14**).
5. Insert a second tire iron next to the first to hold the bead over the rim. Then work around the tire with the first tire iron, prying the bead over the rim (**Figure 15**). Be careful not to pinch the inner tube with the tire irons.
6. Remove the valve from the hole in the rim and remove the tube from the tire.

NOTE: Step 7 is required only if it is necessary to completely remove tire from rim such as for tire replacement.

7. Insert a tire iron between the back bead and the side of the rim that the top bead was pried over (**Figure 16**). Force the bead on the opposite side from the tire iron into the center of the rim. Pry the back bead off the rim working around as with the first.

Tube Inspection

1. Install the valve core into the valve stem and inflate the tube slightly. Do not overinflate.

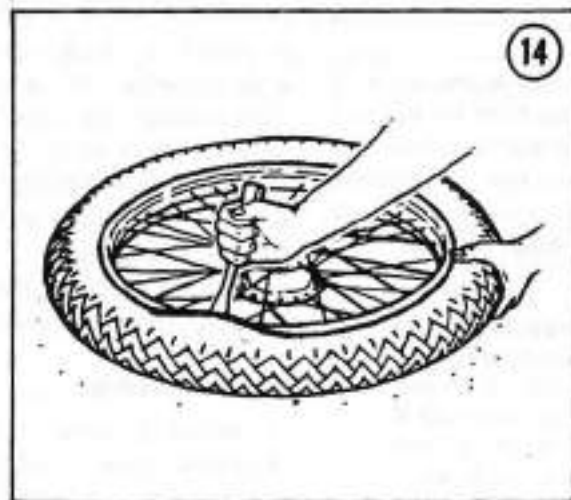
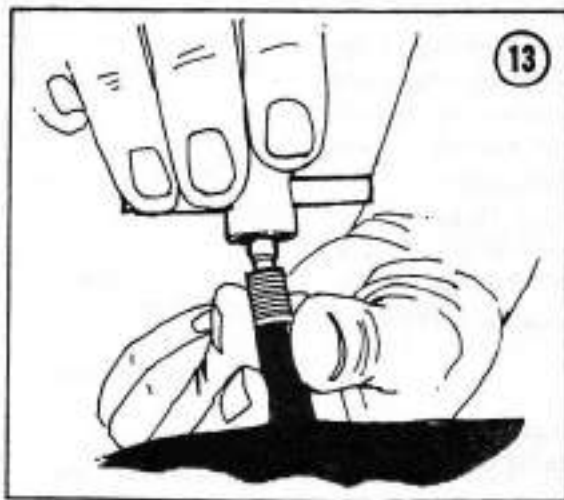
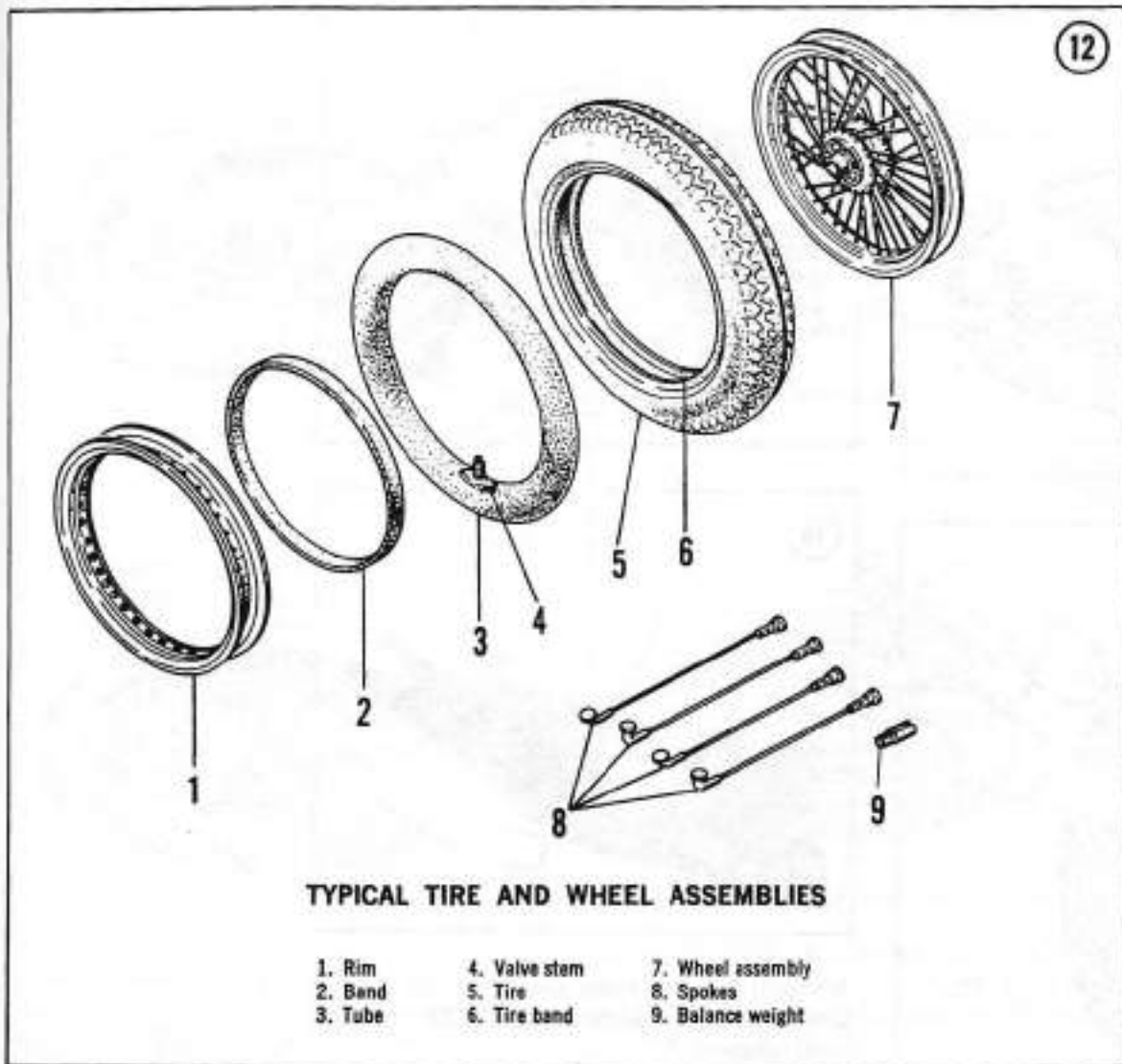

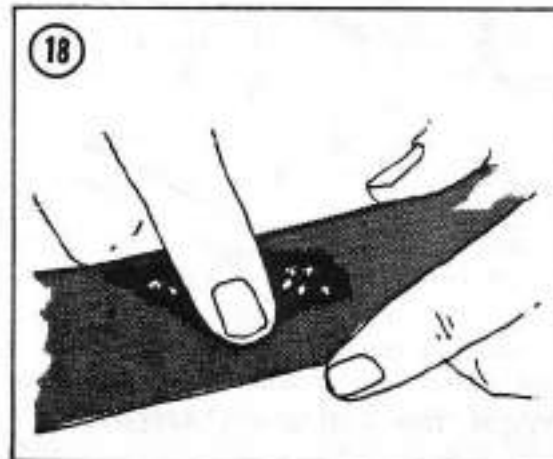
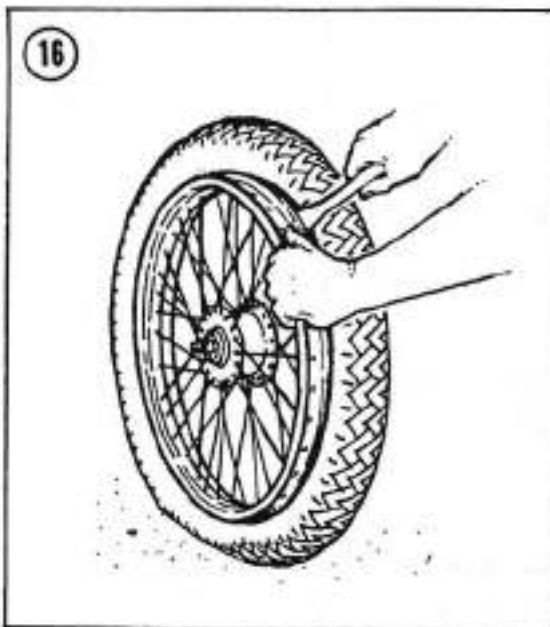
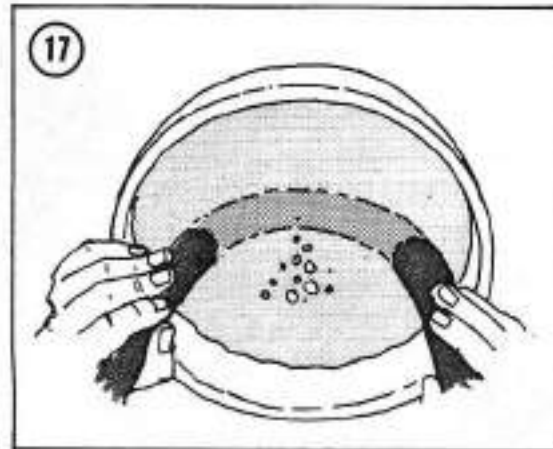
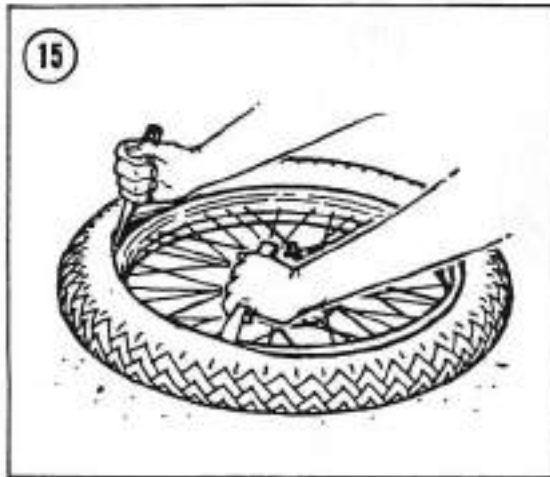

2. Immerse the tube in water a section at a time. See **Figure 17**. Look carefully for bubbles indicating a hole. Mark each hole and continue checking until you are certain that all holes are discovered and marked. Also make sure that the valve core is not leaking; tighten it if necessary.

NOTE: *If you do not have enough water to immerse sections of the tube, try running your hand over the tube slowly and very close to the surface. If your hand is damp, it works even better. If you suspect a hole anywhere, apply some saliva to the area to verify it (**Figure 18**).*

3. Apply a patch using either the hot or cold patch techniques described under *Tire Repairs* in this chapter.

4. Dust the patch area with talcum powder to prevent it from sticking to the tire.

5. Carefully check inside the tire casing for glass particles, nails or other objects which may have damaged the tube. If inside of tire is split, apply a patch to the area to prevent it from pinching and damaging the tube again.

6. Check the inside of the rim. Make sure the rim band is in place, with no spoke ends protruding, which could puncture the tube.

7. Deflate tube prior to installation in the tire.

Tire Installation

1. Inflate the tube just enough to round it out. Too much air will make installation difficult.

2. Place the tube inside the tire.

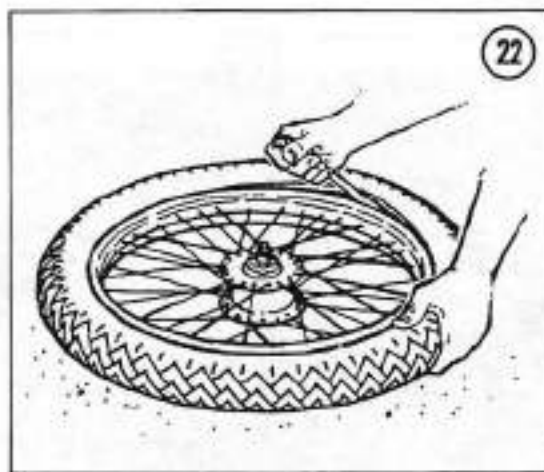
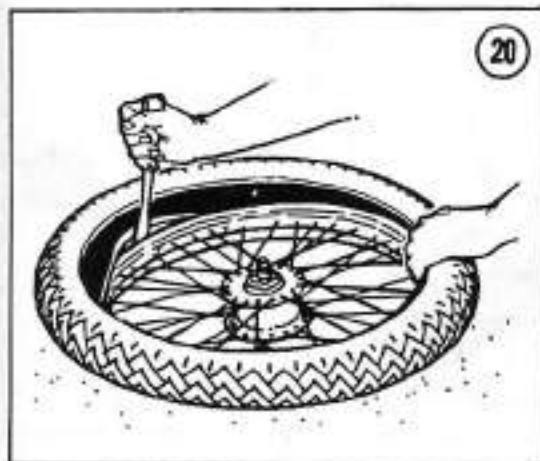
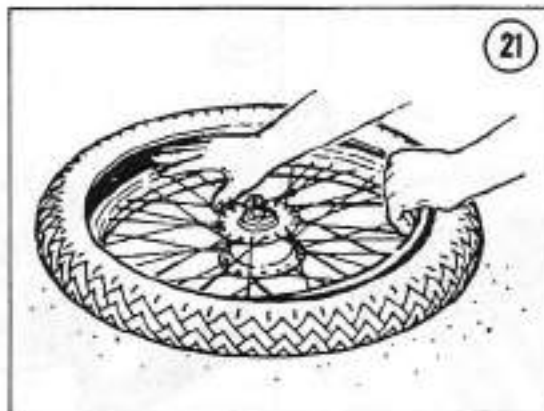
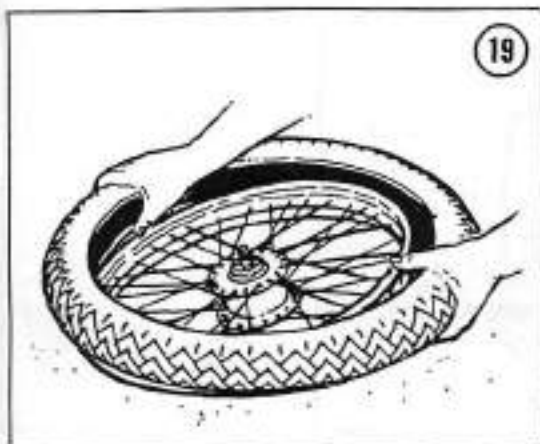

3. Place back side of the tire into center of rim and insert the valve stem through the rim hole (Figure 19). The lower bead should go into the center of the rim with the upper bead outside it.

4. Starting opposite the valve stem, press the lower bead into the rim center, working around the tire in both directions. Use a tire iron for the last few inches of bead (Figure 20).

5. Press the upper bead into the rim opposite the valve (Figure 21) and work around the tire in both directions with your hands. Use a tire iron for the last few inches of bead (Figure 22).

6. Wiggle the valve to be sure the tube is not under the bead. Set the valve squarely in its hole before screwing in the valve nut to hold it against the rim.

7. Check the bead on both sides of the tire for even fit around the rim. Inflate the tire slowly to seat the beads in the rim. It may be necessary

to bounce the tire to complete the seating. Inflate to correct pressure: front tire, 28 lb.; rear tire, 34 lb. *Persons weighing over 175 lb. should add 2 lb. to each tire.*

TIRE REPAIRS

Tire/tube damage will eventually strike even the most careful rider. Repair is fairly simple on all tires.

Tire Repair Kits

Tire repair kits can be purchased from moped or motorcycle dealers and some auto supply stores. When buying, specify that the kit you want is for moped tires.

There are two types of tire repair kits for mopeds:

- a. Hot patch
- b. Cold patch

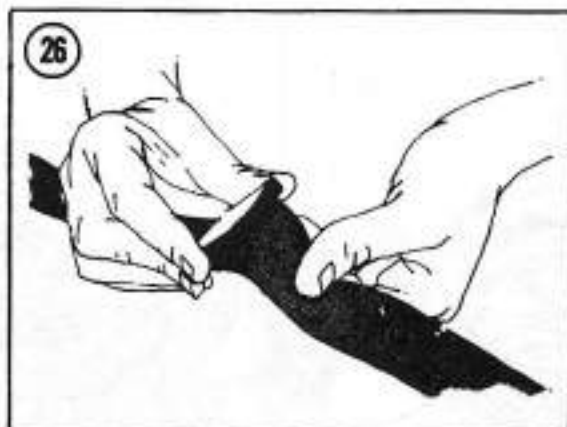
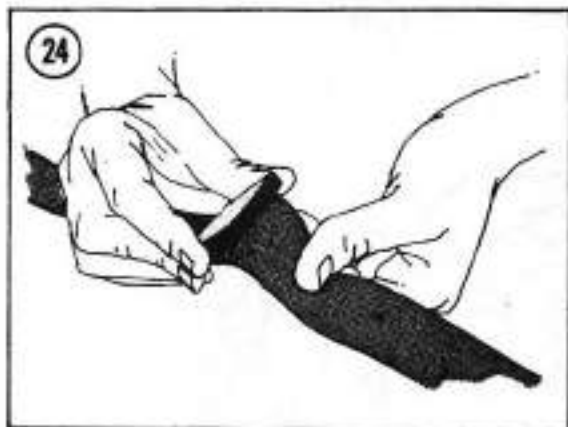
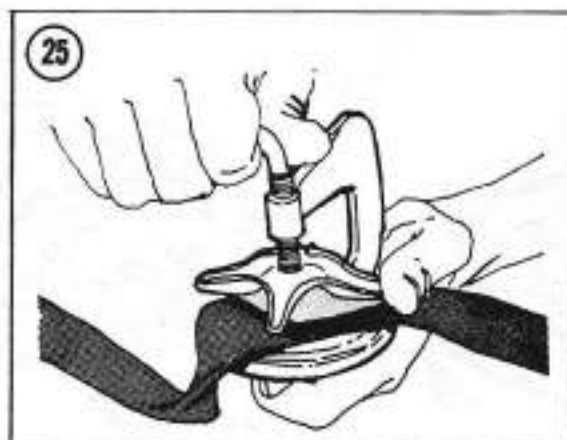
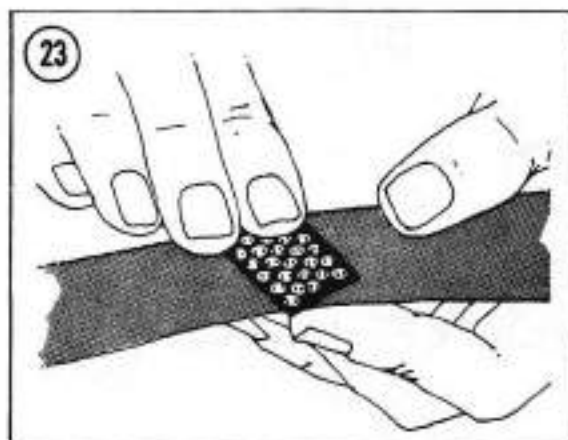

Hot patches are strongest because they actually vulcanize to the tube, becoming part of it. The repair kit for hot patching is bulkier and heavier than cold patch kits, therefore, hot patch kits are more suited for home repairs.

Cold patches are not vulcanized to the tube; they are simply glued to it. Though not as strong as hot patches, cold patches are still very durable. Cold patch kits are less bulky than hot and more easily applied under adverse conditions. Cold patch kits are best for emergency repairs on the road.

Hot Patch Repair

1. Remove the tube from tire as described under *Tire Removal* in this chapter.
2. Roughen area around hole slightly larger than the patch (Figure 23). Use a pocket knife or similar tool to scrape the tube; be careful that you don't cause further damage.
3. Remove the backing from patch.

CAUTION

Do not touch newly exposed rubber with your fingers. This will prevent a good seal.

4. Center the patch over hole (Figure 24).
5. Install clamp around tube so that it holds the fuel container over the patch (Figure 25).
6. Pry up a corner of the fuel and light it. Let all of the fuel burn away.

CAUTION

The clamp gets hot, so don't touch it until it cools.

7. Remove the clamp and peel the tube off the fuel container (Figure 26).

Cold Patch Repair

1. Remove the tube from tire as described under *Tire Removal* in this chapter.

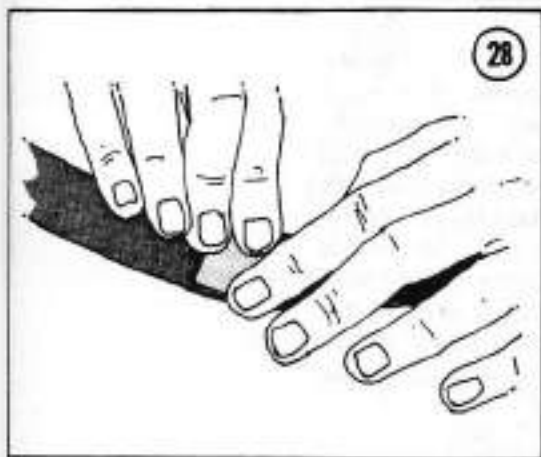
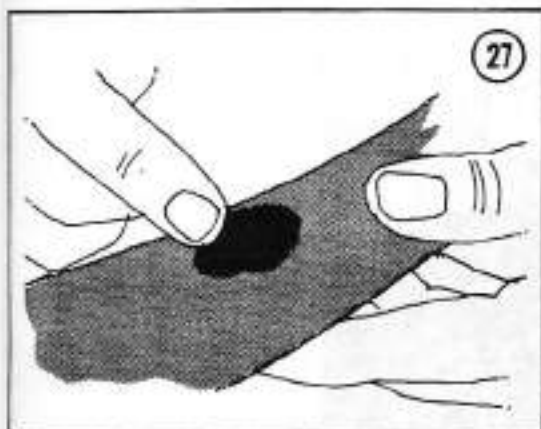

2. Roughen area around hole slightly larger than the patch, use a cap from tire repair kit or pocket knife. Do not scrape too vigorously or you may cause additional damage.
3. Apply a small quantity of special cement to the puncture and spread it evenly with a finger (Figure 27).
4. Allow the cement to dry until tacky — usually 30 seconds or so is sufficient.
5. Remove the backing from the patch.

CAUTION

Do not touch the newly exposed rubber with your fingers or the patch will not stick firmly.

6. Center patch over hole. Hold patch firmly in place for about 30 seconds to allow the cement to set (Figure 28).
7. Dust the patched area with talcum powder to prevent sticking.

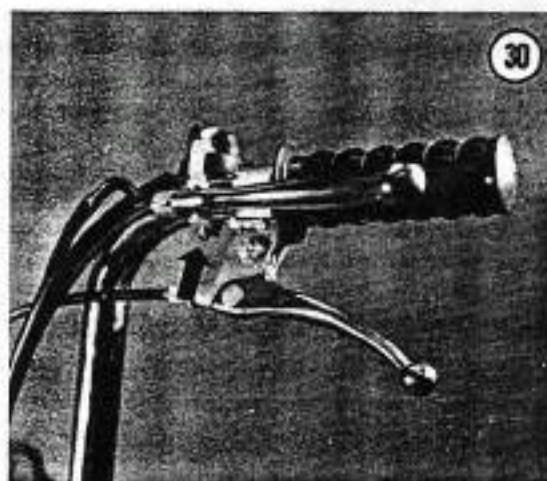
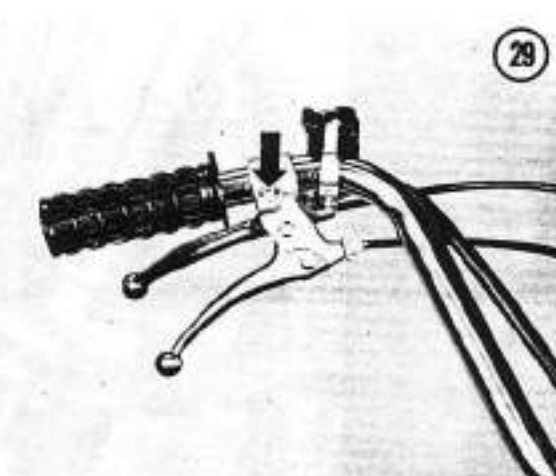

HANDLEBAR

Removal/Installation

1. Loosen, but do not remove, the screw securing the hand grips to the handlebar (Figure 29).
2. Slide off both hand grip assemblies, it is not necessary to remove the cables from the grips. Lay the grip assemblies over the fuel tank, hooking them on the fill cap. Be careful not to kink the cables.
3. Remove the switches by removing the screw on the underside of the clamp (Figure 30). Slide switches off of the end of the handlebar.
4. Loosen the nut on top of the steering neck (Figure 31).
5. After the bolt is loose, strike it with a hammer to loosen the tapered expander inside the headset.

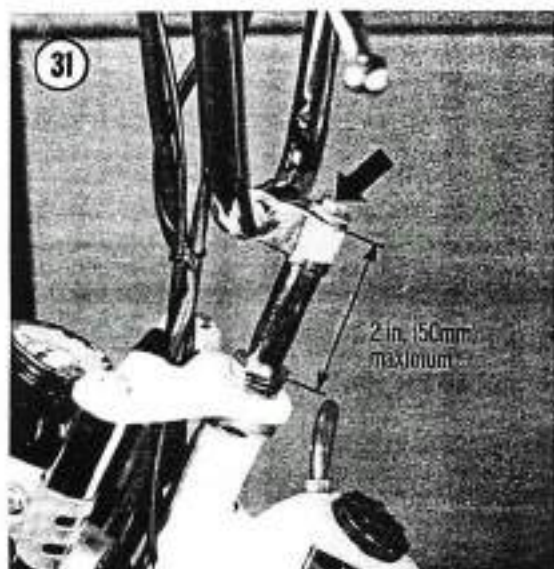

6. Pull the handlebar straight up and out of the headset.
7. Install by reversing the removal steps.

CAUTION

The handlebar stem must not stick out above the headset locking nut, more than 2 in. (50mm). See Figure 31.

Adjust the handlebar and hand grip assemblies to your comfort.

HEADSET

The headset consists of parts inside the head tube which secure the fork to the frame and permit it to turn. Refer to **Figures 32 and 33** for all related parts.

Adjustment

If the fork turns stiffly or feels overly loose, it probably requires adjustment.

1. Loosen the locknut (A, **Figure 34**).
2. Loosen the adjusting race (B, **Figure 34**), tighten it hand tight, then back it off (counterclockwise) $\frac{1}{4}$ turn. Tighten the locknut.
3. Turn the wheel back and forth. If it feels stiff, loosen the locknut and loosen the adjusting race another $\frac{1}{4}$ turn. Tighten the locknut. If it still feels stiff, it requires overhauling as described under *Headset Disassembly/Assembly/Inspection* in this chapter.

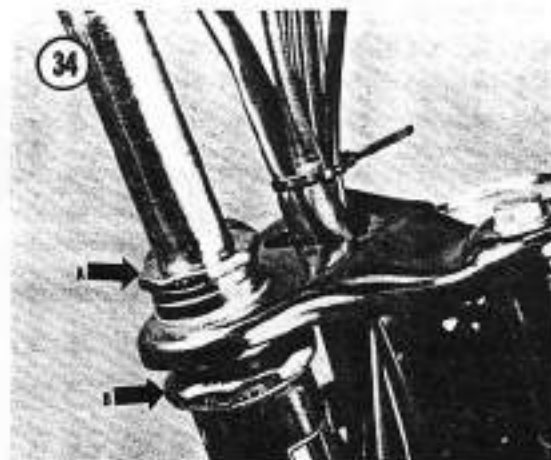

4. Check the fork for excessive play. Lift the front wheel clear of the ground, then set it down; look for vertical play. Now hold the handlebar with one hand and a fork tube with the other. Try to wiggle the assembly from side to side, looking for horizontal play. If there is any vertical or horizontal play, loosen the locknut and tighten the adjusting race $\frac{1}{4}$ turn. Tighten the locknut and recheck play. If it is still present, it requires overhauling as described under *Headset Disassembly/Assembly/Inspection* in this chapter.

Disassembly

Headset disassembly requires the removal of the front wheel and front forks. The headset assembly is the same on all models and is used with both fork configurations. This procedure may be done with the moped on the centerstand, with the rear end tied down, or it may be laid down on its side on a blanket or thick pad.

1. Remove the front wheel as described under *Front Wheel Removal/Installation* in this chapter.
2. Remove the handlebar as described under *Handlebar Removal/Installation* in this chapter.

NOTE: *It is not necessary to remove the handgrip assemblies or switches. Cover the fuel tank with a cloth prior to placing the handlebar on it.*

Turn the handlebar upside down and lay back over onto the fuel tank. Be careful not to kink any of the cables.

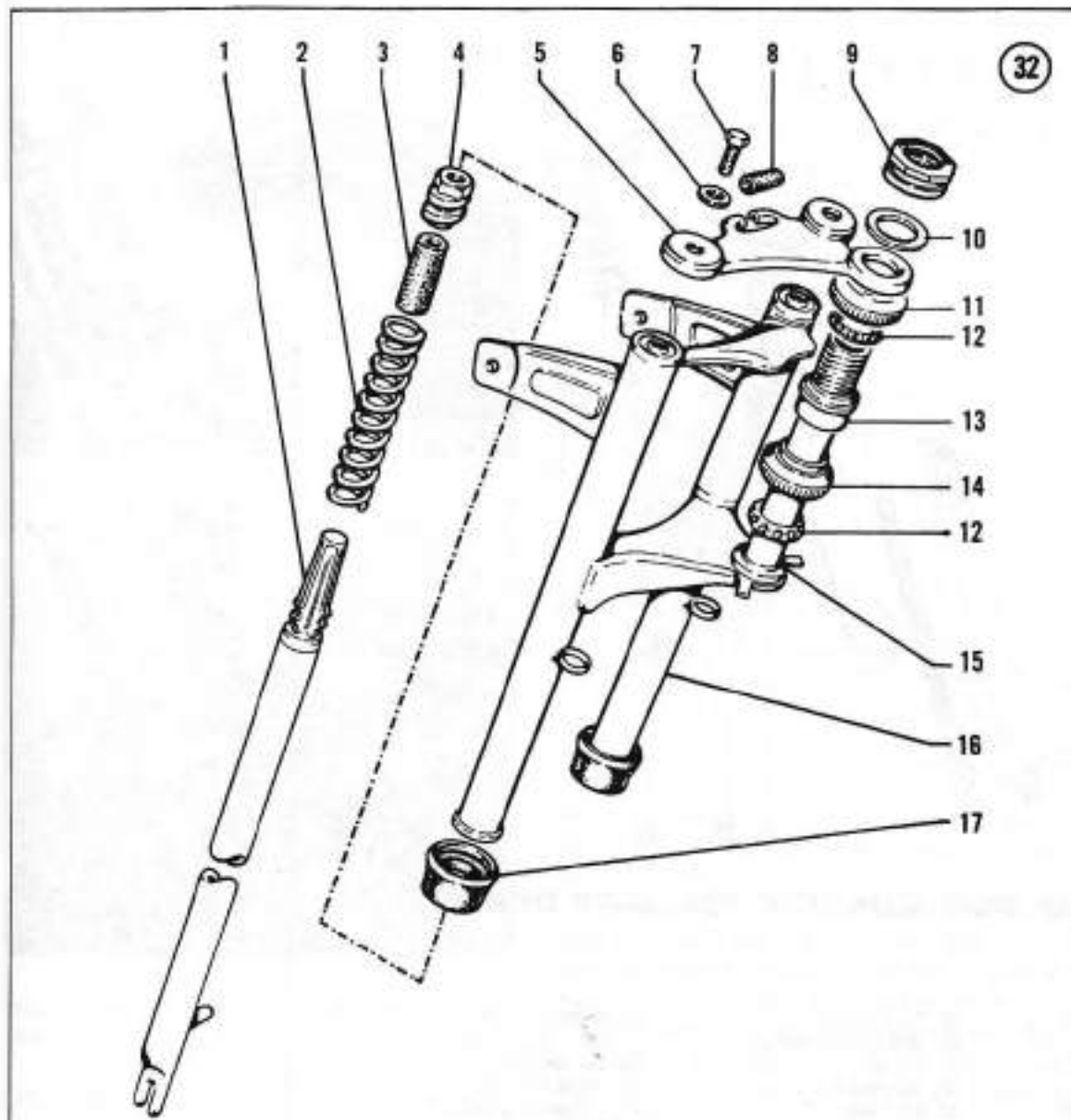

HEADSET — EUREKA STANDARD, EUREKA DELUXE, AND SPORT

- | | | |
|------------------------|--------------------------|--------------------------------|
| 1. Lower fork tube (2) | 7. Bolt (2) | 13. Upper headset bearing race |
| 2. Coil spring (2) | 8. Protective sleeve | 14. Lower headset bearing race |
| 3. Spring cap (2) | 9. Steering head locknut | 15. Lower headset cone |
| 4. Spring cover (2) | 10. Washer | 16. Upper fork assembly |
| 5. Top fork plate | 11. Adjusting nut | 17. Rubber boot (2) |
| 6. Washer (2) | 12. Ball bearing (2) | |

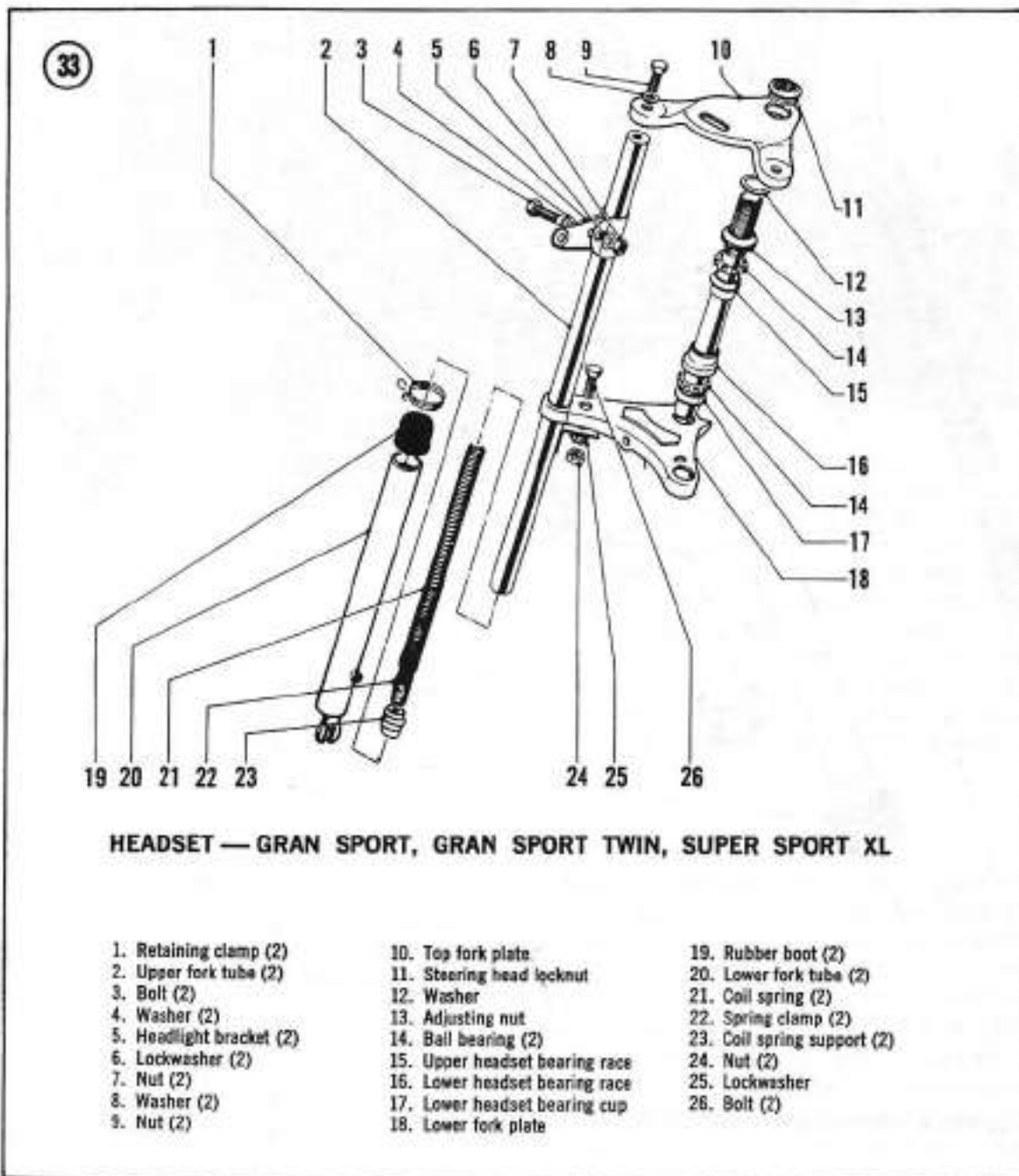

6. Unscrew and remove the adjusting nut. Remove the upper ballbearing.

7. Slowly pull the fork assembly and steering stem out from the head tube.

8. Assemble by reversing the removal steps.

9. After assembly steps are completed, it is necessary to readjust the head set as described under *Headset Adjustment* in this chapter. Also

3. Remove the 2 bolts securing the headlight housing and side reflectors (Figure 35). Lay the headlight housing on top of the fuel tank.

4. Remove the 2 cap nuts (A) and washers securing the top fork plate (Figure 36).

5. Remove the steering head locknut (B, Figure 36) and washer. Remove them and the top fork plate.

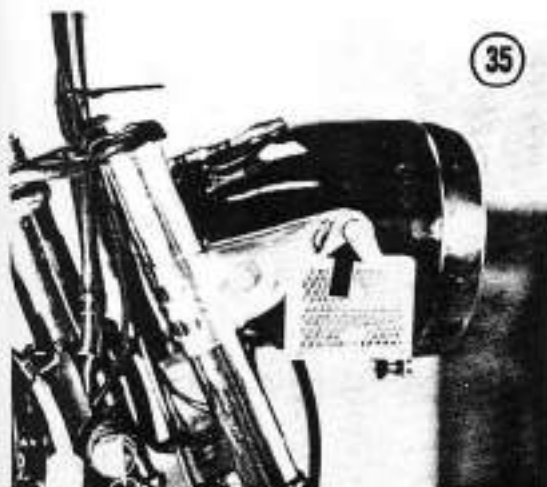

35

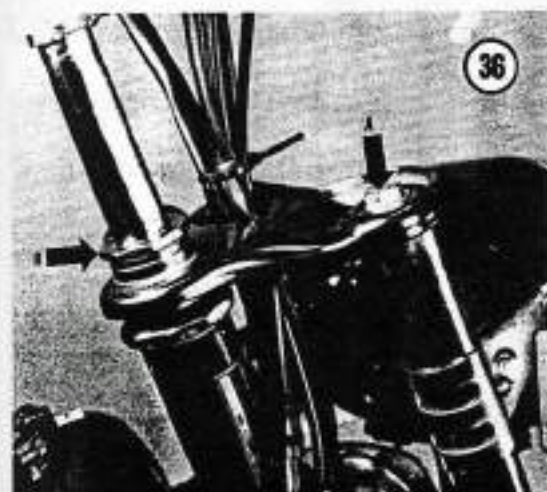

36

readjust the headlight as described under *Headlight Adjustment* in Chapter Eight.

Inspection

1. Clean all parts in cleaning solvent.
2. Check bearings for pitting, scratches or discoloration which indicates wear. Replace them if necessary; take old bearings to dealer to ensure exact replacement.
3. Check upper and lower headset bearing races and top adjusting race for pitting, scratches and discoloration which indicate wear. Replace if necessary.

Bearing Race Replacement

The headset bearing races are pressed into place. Because they are easily bent, do not

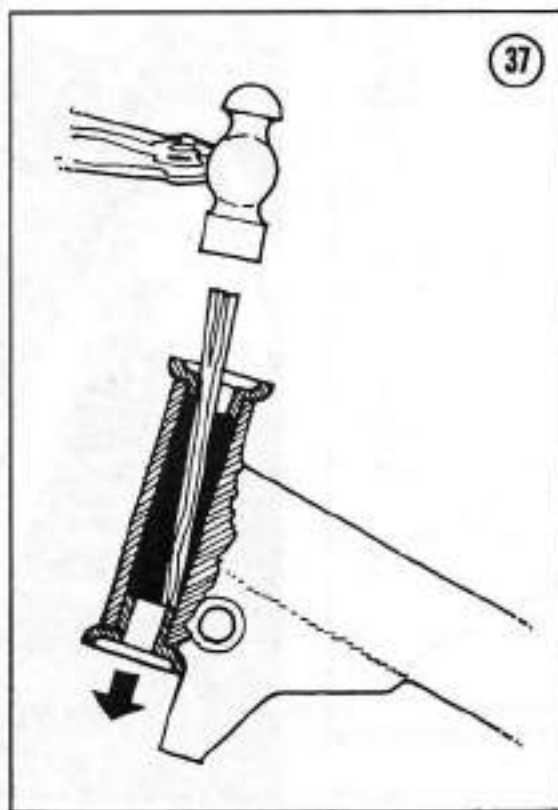

37

remove them unless they are worn and require replacement. Take old races to dealer to ensure exact replacement.

To remove a headset race, insert a hardwood stick into the head tube and carefully tap the race out from the inside (Figure 37). Tap all the way around the race so that neither the race nor the head tube are bent. To install the race, fit it into the end of the tube. Tap it slowly and squarely with a block of wood as shown in Figure 38.

NOTE: The upper and lower races are different. Refer to Figures 32 and 33 to be sure that you install them at the proper end of the head tube.

FRONT FORK

Refer to Figure 32 for Eureka Standard, Eureka Deluxe and Sport models.

Refer to Figure 33 for Gran Sport, Gran Sport Twin and Super Sport XL models.

This procedure may be done with the moped on the centerstand and the rear end tied down, or laid on its side on a blanket or thick pad.

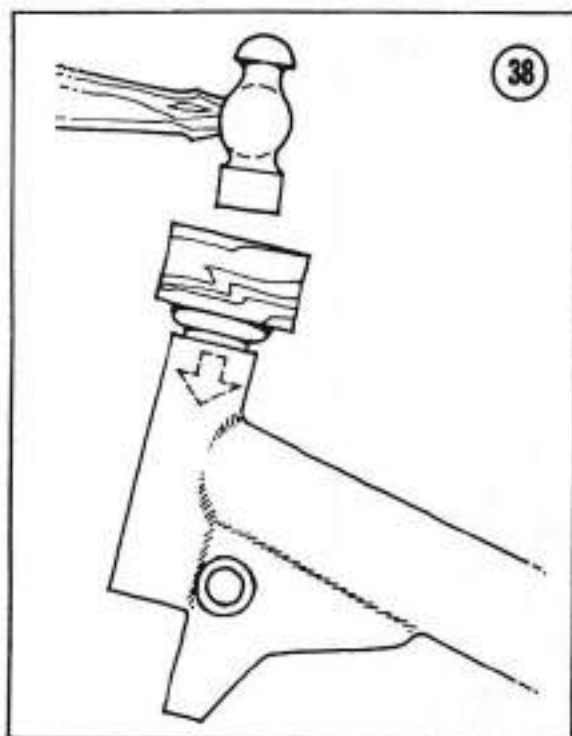

It is suggested that you disassemble one side at a time.

Removal/Installation

1. Remove the front wheel as described under *Front Wheel Removal/Installation* in this chapter.
2. Remove the fender bracket bolt (Figure 39).

NOTE: When the bolt is removed the lower fork tube will rotate slightly due to the "wrap up" of the spring.

3. Squeeze the rubber boot retaining clamps and push the boot up on the upper fork tube. Let the boot remain with the upper fork tubes (Figure 40).
4. Remove the cap nut (A) and lockwasher (Figure 34) while holding the lower fork tube.
5. Slide off the lower fork tube complete with the internal spring.
6. Install by reversing the removal steps.

Inspection

Remove the coil spring and inspect it. If the grease looks as though it is not contaminated, do not remove it. Add a good grade of multi-purpose grease to it if necessary.

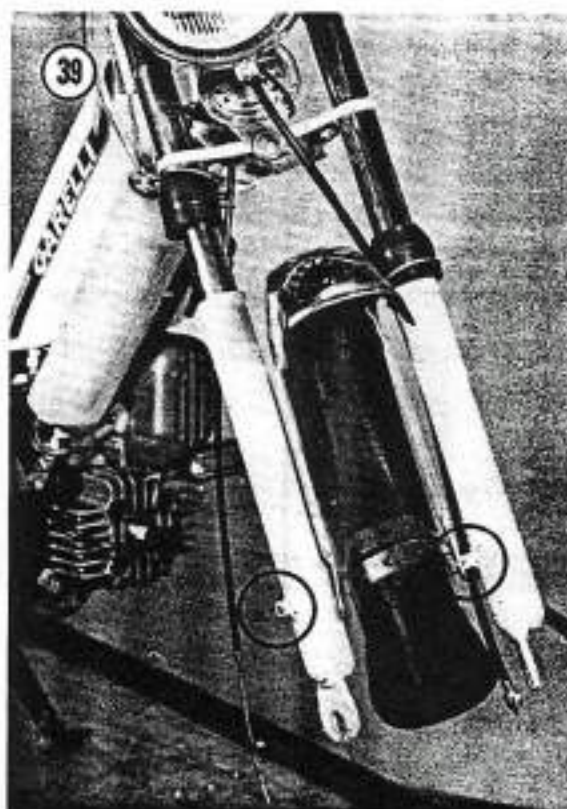

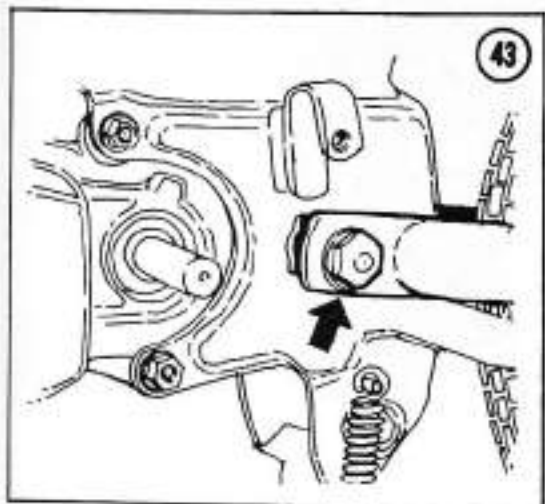
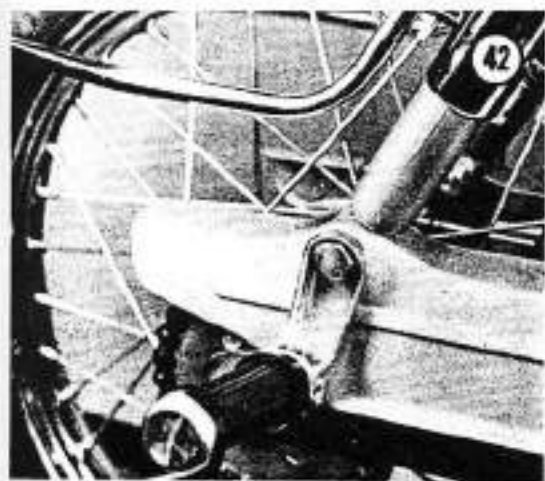
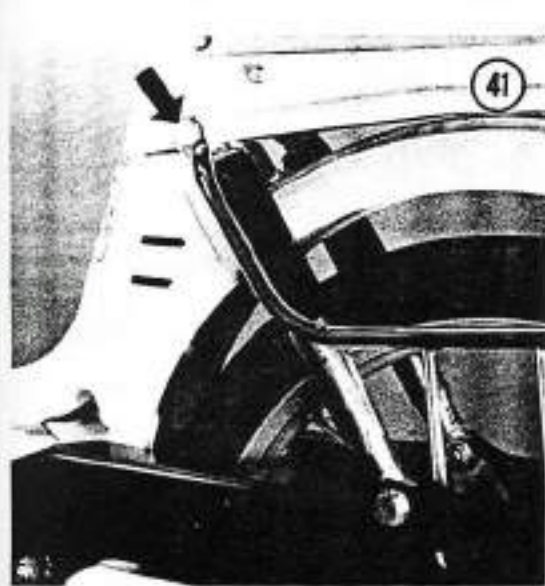

If the grease packed around the spring has been contaminated with dirt or water, the spring should be thoroughly cleaned with cleaning solvent. Wipe out the inside of the upper fork tube with rags on a long rod; avoid pouring cleaning solvent into the tube as it is difficult to thoroughly dry out.

Repack the spring and coat the inside of the upper tube with a good grade of multipurpose grease.

REAR SHOCK ABSORBERS

Sport models are not equipped with rear shock absorbers.

Always replace shock absorbers as a pair; do not replace only one as this will affect the road handling of the moped.

1. Place the moped on the centerstand.
2. Remove the upper and lower bolt and washer on each side (Figure 41). On Gran Sport Twin also remove the foot pegs (Figure 42).

NOTE: Hold inside nut at top through a slot in the luggage rack.

3. Remove the old shocks.
4. Install by reversing the removal steps. When installing the bolts be careful not to damage the rubber bushings of the new shocks.

REAR SWING ARM

Sport models are not equipped with a swing arm.

Removal/Installation

1. Place the moped on the centerstand.
2. Remove the rear wheel as described under *Rear Wheel Removal/Installation* in this chapter.
3. Remove the right-hand chain guard.
4. Remove the left-hand trim panel (Figure 41).
5. Remove the nut from the pivot bolt (Figure 43). Tap out the pivot bolt with a drift punch and hammer.
6. Remove the swing arm from the frame.
7. Install by reversing the removal steps.

CENTERSTAND

1. Place old blanket or pad on floor and lay moped down on its side.
2. Place the centerstand in the raised position and remove return spring using a pair of pliers to pull the hook off of the attachment loop (Figure 44).
3. Remove the circlip (Figure 45) and tap out the pivot pin with a drift punch and hammer.

NOTE: Figure 44 is shown with the muffler removed for clarity. It is not necessary to remove it for this procedure.

4. Install by reversing removal steps. Apply a small amount of multipurpose grease to the points where the centerstand rotates on the rear swing arm.

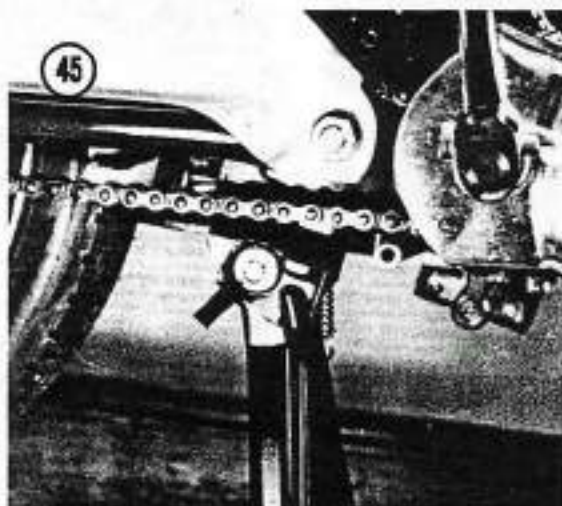
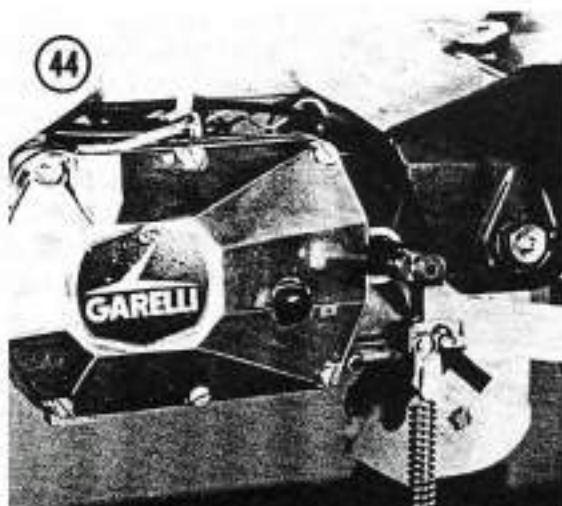

SEAT

Removal/Installation (Eureka Standard, Eureka Deluxe, Sport, Gran Sport)

Loosen, but do not remove, the bolt securing seat and stem into the seat support unit of the frame (Figure 46). Pull the seat and stem up and out to remove.

Install by reversing the removal steps, adjust the seat to the proper height.

Removal/Installation (Super Sport XL)

Remove the 2 bolts, washers, lockwashers and nuts securing the rear of the seat to the luggage carrier. Pull seat to the rear and remove.

Install by reversing the removal steps.

Removal/Installation (Gran Sport Twin)

Remove the 2 bolts, washers, lockwashers and nuts (Figure 47) securing the rear of the seat to the luggage carrier.

Pivot the seat upward from the rear and loosen, but do not remove, the bolt securing the seat and stem into the seat support unit of the frame (Figure 47). Pull the seat and stem up and out to remove.

Install by reversing the removal steps.

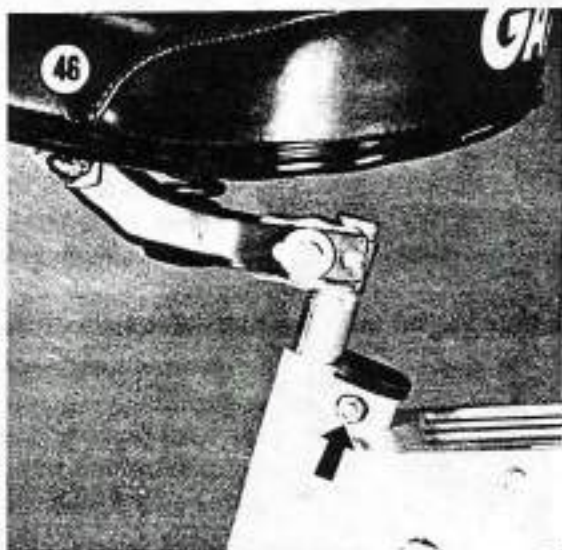

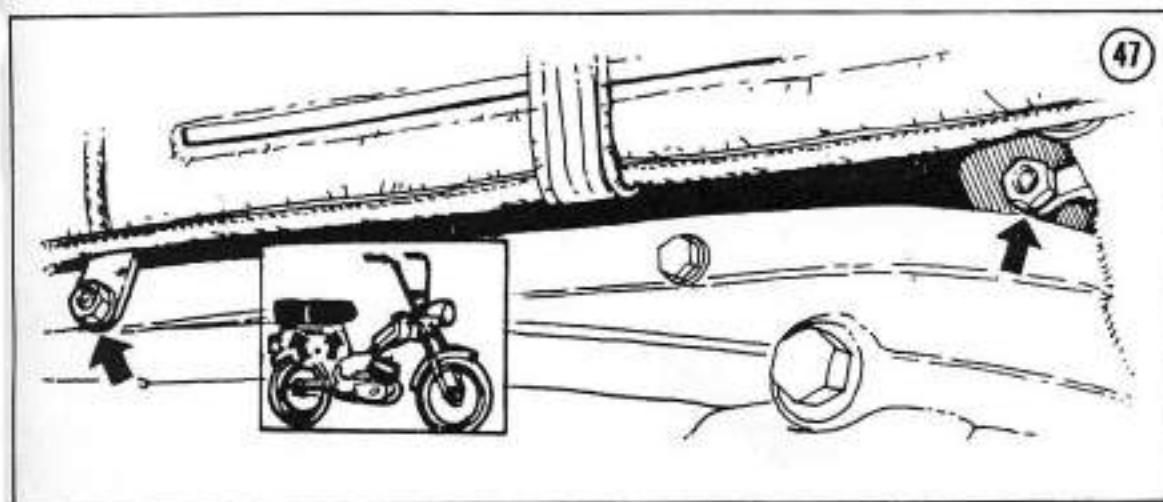

INDEX

- A**
- Air filter 85-86
- B**
- Brakelight 95-96
- Brakes
- Adjustment 25
 - Cable 98-99
 - Drum 100
 - Lining 99-100
 - Troubleshooting 30
- Breaker points 17-20, 92-94
- C**
- Cables 23
- Carbon removal 21-23
- Carburetor
- Adjustment 20-21
 - Overhaul and cleaning 81-84
- Centerstand 118
- Chain 24-25
- Cleaning solvents 23
- Clutch
- Chain 78-80
 - Clutch start cable 76-77
 - Crankarm 77-78
 - Inspection 75-76
 - Lubrication 23
 - Pedals 77
 - Removal and installation, Eureka, Sport, Gran Sport, Super Sport XL 62-69
 - Removal and installation, Gran Sport Twin 69-75
 - Start cable adjustment 25
 - Troubleshooting 30
- Components, description 1-4
- Connecting rods 61
- Cooling, engine 31
- Crankcase 50-61
- Crankshaft 61
- Cylinder 44-47
- Cylinder head 40-44
- D**
- Drive chain 24-25
- E**
- Electrical system
- Horn 96
 - Lights 94-96
 - Magneto 89-94
 - Switches 95-96
 - Troubleshooting 30
 - Wiring diagram 97
- Engine
- Cooling 31
 - Crankcase 50-61
 - Crankshaft 61
 - Cylinder 44-47
 - Cylinder head 40-44
 - Decarbonization 21
 - Lubrication 31
 - Piston ring 49-50
 - Piston and wrist pin 47-49
 - Principles of operation 31
 - Removal and installation 35-40
 - Troubleshooting 28-30
- Exhaust system 87-88
- F**
- Frame 111-119
- Front fork 115-117
- Fuel system
- Air filter 85-86
 - Carburetor 81-84
 - Fuel filter 84
 - Fuel shutoff valve 84-85
 - Fuel tank 86-87
- G**
- General information 1-6
- H**
- Handlebar 111-112
- Headlight 94-96
- Headset 112-115
- Horn 30, 96
- Hubs 23, 102-106
- I**
- Ignition timing, magneto 17-20

- L**
- Lights30, 94-96
 Lubricants 23
 Lubrication, engine 31
 Lubrication, periodic23-24
- M**
- Magneto17-20, 89-94
 Maintenance, periodic 24-26
 Muffler21-23, 87-88
- P**
- Parts replacement 6
 Pedals 24
 Piston, pin, and ring47-50
- S**
- Safety 6
 Seat 118
 Service hints 4-5
 Shock absorbers, rear 117
 Solvents 23
 Spark plug14-16
 Speedometer illumination light 95
 Spokes26, 106
 Storage 26
 Supplies, expendable 6
 Suspension30, 115-119
 Swing arm, rear 117
- T**
- Taillight 95
 Thread patterns, nuts, bolts, and screws 8, 12
 Timing, magneto ignition17-20
 Tires and tubes106-111
- Tools**
- Cable cutter 11
 Fasteners 7-8
 Ignition gauge 10
 Impact driver 10
 Mechanic's tips12-13
 Pliers 8
 Screwdrivers 8
 Spoke wrench 11
 Tire lever10-11
 Wrenches 8-10
- Troubleshooting**
- Brakes 30
 Clutch 30
 Electrical 30
 Emergency troubleshooting 28
 Engine28-30
 Operating requirements27-28
 Suspension 30
- Tune-up**
- Air filter 21
 Breaker points17-20
 Carburetor20-21
 Decarbonizing21-23
 Magneto17-20
 Spark plug14-17
- W**
- Wheels101-111
 Wiring diagram 97

GARELLI

MOPED

OWNER SERVICE / REPAIR

1976-1978

Eureka Standard

Eureka Deluxe

Sport

Gran Sport

Gran Sport Twin

Super Sport XL

This manual is part of the first professionally-written do-it-yourself repair series for moped enthusiasts. Fully detailed procedures on tune-up, troubleshooting, lubrication, and major maintenance enable owners to perform virtually any repair required.

The text is by an expert technical writer, and has been illustrated by scores of photos and drawings prepared especially for this book. Emphasis throughout is on simple step-by-step procedures and the remedies needed for reliable operation.

Specific areas of coverage include: the engine, fuel system, cooling system, electrical system, power train, suspension, and steering.

As in all Clymer service books, the goal has been to help owners understand their equipment, lower repair costs, and generally improve operating satisfaction. Clymer moped, snowmobile, motorcycle, auto, and marine maintenance books are sold worldwide. Look for them at your local dealer, parts supplier, or bookstore.

CLYMER PUBLICATIONS + LOS ANGELES

GARELLI MOPED OWNER SERVICE / REPAIR

1976-1978

**M435 CLYMER
PUBLICATIONS**