



CFMOTO

V NIGHT Motorcycle

CF150-2C OWNER'S MANUAL



Foreword

This instruction gives detailed introduction to the basic operation and maintenance methods of CFMOTO CF150-2C Model motorcycle. Please carefully read this instruction before driving.

Proper use, maintenance and service will effectively safeguard driving safety, reduce failure of motorcycle, maintain optimum performance of the motorcycle and prolong service life of the vehicle.

The “CFMOTO Service Station” of the company will provide high-quality after-sale service for you. The data, specification and introduction in this instruction are determined according to the latest design of the company at present and Zhejiang CFMOTO Power Co. , Ltd. reserves the right to update them at any time. For any technical change to this vehicle in the future, the company will give no further notice.

Thank you for choosing “CFMOTO” motorcycle!

Wish to bring you comfortable, rapid and delightful experience in the future journey.

The implementation standard of this product (CF150-2C) is: Q/CFD013-2011

Notes

Please carry out operations according to the traffic laws and regulations and the provisions of this maintenance instruction.

This maintenance instruction is one of the necessary accessories of this vehicle. When the vehicle is transferred to other person, please transfer the vehicle with this instruction.

The copyright of this maintenance instruction belongs to Zhejiang CFMOTO Power Co. , Ltd. . Without written consent of the company, this instruction should not be reproduced or re-printed. All rights reserved.

Compilation of this maintenance instruction should meet the provisions of GB9969.1-1998 and GB/T19678-2005 standards.

The interpretation right of this maintenance instruction belongs to Zhejiang CFMOTO Power Co., Ltd..

CONTENTS

1.CF150–2C Model Motorcycle Overview	(1)
2.User Guide	(3)
3.Transportation, Storage and Unpacking Installation of Motorcycle ...	(4)
4.Safe Driving of the Motorcycle	
(1)Rules for Safe Driving	(5)
(2) Safety Protection Equipment	(6)
(3) Vehicle Retroffting	(7)
(4) Loading of the Goods	(8)
(5) Accessories	(8)
5.Operation Instruction	
(1) Location of Parts.....	(9)
(2) Instrument and Ignition Switch.....	(12)
(3) Right Handle Switch Set	(16)
(4) Left Handle Switch Set	(17)
(5) Fuel and Fuel Tank Cover	(19)
(6) Selection of Lubricating Oil	(20)
(7) Tire	(21)
6. Operation Guidance	
(1).Run-in Period.....	(22)
(2) Inspection before Driving	(24)
(3) Start-up of Motorcycle	(25)
(4) Motorcycle Driving	(27)

7.Maintenance and Service

(1) Maintenance Periodic Table	(31)
(2) Inspection and Replacement of the Lubricating Oil of the Engine	(33)
(3) Selection and Replacement of the Spark Plug	(35)
(4) Cleaning and Assembly of the Air Filter.....	(36)
(5) Inspection and Adjustment of the Throttle Handle	(37)
(6) Clutch Adjustment	(39)
(7) Inspection, Adjustment and Lubrication of the Drive Chains	(41)
(8) Inspection and Adjustment of the Front Brake	(43)
(9) Inspection and Adjustment of the Rear Brake	(45)
(10) Maintenance of Storage Battery.....	(47)
(11) Application Maintenance Instructions to Electronic Fuel Injection (EFI) and Fuel Evaporation Recovery System	(51)
(12) Vehicle Cleaning and Storage	(53)
(13) Vehicle Service Life and Vehicle Handling	(55)
(14) Relevant Adjustment Data of Motorcycle	(56)
(15) CF150-2C Main Technical Parameters Table.....	(57)
(16) CF150-2C Electrical System Diagram.....	(60)
(17) Common Failure and Cause of the Motorcycle	(61)

1.CF150–2C Model Motorcycle Overview

With compact structure, CF150-2C model motorcycle has featured, unique and novel appearance. The riding is comfortable and driving stability is good. It adopts the latest water-cooled engine researched and developed by the company and it adopts the electronic fuel injection system, which makes it more environmental-friendly with lower fuel consumption and emission, reaching Chinese National Phase III Emission Standards Euro III Emission level.

(1)Applicable Scope of CF150–2C Model Motorcycle

CF150-2C is one motorcycle promoted by CFMOTO with independent development.

This vehicle can not only be the traffic tools for commuters and tourism and leisure activities and also can be heavy transportation tool.

Therefore, CF150-2C motorcycle is not only suitable for urban roads but also for countryside roads.

(2) Characteristics of CF150–2C Model Motorcycle

1.Strong power and heavy load.

The engine model of this vehicle: 157MJ-3A(A1)

Maximum net power: 10.5kW (9000rpm). When the engine is at 9000 RPM the output power is 10.5kw.

2. Big torque force and strong gradeability.

The maximum torque: 12.2N • m (6500 rpm). When the engine is at 6500 RPM the output torque is 12.2 N • m.

3.Fuel evaporation recovery system and optimized muffler catalyzer.

It makes it more environment-friendly with lower fuel consumption and more thorough combustion. The combustion structure is more reasonable and the system completely reaches National Phase III Emission Standard.

4.State-of-the-art water-cooling technology.

As the professional enterprise that produces water-cooled engines, the “Water-cooling” technologies of CFMOTO are at the top level. Compared to the air-cooled engines with the same displacement: it has better heat dissipation and the temperature adjustment of the engine oil is more flexible with higher power, lower fuel consumption and has prolonged service life of engine.

5. DC power supply system.

The charging efficiency is higher. More lighter and make it easier to drive in the night.

2. User's Guide

1. Regulations on load carrying:

Load carrying of CF150-2C model motorcycle: 2 persons (including 1 driver and 1 passenger).
The maximum allowable load carrying capacity is: 150kg.

2. Fuel

The fuel used in this vehicle is: 93# octane gasoline.

Since gasoline is highly flammable, if the fuel tank, fuel filter, fuel pipeline, and other accessories of the vehicle cause oil leakage due to damage and aging, the users should use the vehicle after timely repair and troubleshooting.

3. Electric system

The user cannot retrofit or change the circuit of the vehicle on its own nor enlarge or add electric equipment. It will make the electrical equipment of the vehicle overloaded, resulting in overheated circuit, melted fuse or short circuit or even spark and car burning and so on.

The company will not be responsible for any consequences due to retrofitting or change of the vehicle circuit or enlarging or adding electric equipment.

4. Inspection

The user should strictly maintain the parts and accessories listed as per requirements of “Periodic Maintenance Table” .

3. Transportation, Storage and Unpacking Installation of Motorcycle

1. The motorcycle (with packaging box) should be reliably secured on the transportation vehicle. During transit, there should be no damage or destruction.
2. The motorcycle (with packaging box) should be stored in clean, well-ventilated, dry, rain-proof and sun-proof warehouse and should not be stored together with the inflammables, chemical corrosives and other hazardous substance.
3. This motorcycle is completely installed at the dealer's and is delivered to the users after commissioning. The installation sequence is as follows:
 - ① Unpack the box and take out all accessories.
 - ② Install handle tube.
 - ③ Disassemble the left, right and front shock absorber retaining bolts, take out the rear wheel and support the vehicle with the side stand or main process stand (matching), install front brake and front wheel, install storage battery, install other accessories (rearview mirror and so on), fasten bolts and nuts of the whole car and inspect the circuit before starting the motorcycle.
 - ④ Adjust light signal, front and rear brakes, clutch, throttle, and so on and deliver it to users after testing. The installation is completed.

Transportation, Storage and Unpacking Installation of Motorcycle are only for references of the dealers.

4. Safe Driving

This motorcycle is two-wheel motor-driven vehicle, which can bring convenience and rapidness to the driver. To ensure the best performance of the motorcycle, you must maintain and service the vehicle correctly. When using the motorcycle, the vehicle must be safe and normal; when driving or riding the motorcycle, you must be healthy in order to control the vehicle in the best state.

Note: When driving the motorcycle, the traffic rules and regulations must be observed; the vehicle must be carefully inspected before driving.

(1) Rules for Safe Driving

1. Before starting the motorcycle, it is necessary to inspect the vehicle carefully in order to ensure that the vehicle is safe and normal; in this way, accidents can be prevented and damage of parts and accessories can be avoided.
2. The motorcycle drivers must pass the exam held by the traffic administration department and obtain “motorcycle driving license” before driving the motorcycle; the vehicle cannot be lent to people without “motorcycle driving license” .
3. To avoid injury, you should:
 - Eye-catching clothing.
 - Don’ t be too close to the other vehicles when driving and use the turn lights, horn, brake lights and so on correctly.
 - Do not drive in the dead zone of other drivers.
4. Strictly pay attention to and observe traffic rules and regulations (including local traffic rules and regulations)
 - Overspeed driving is the main cause of accidents. Therefore, do not exceed the allowable speed of the specific road conditions (requirements).
 - When turning or lane changing, it is necessary to use appropriate signal lights to warn the other drivers.

5. When driving on the road surface of the turning junction, crossroads, entrance and exit of the parking lot, high speed road or with barriers and so on, the driver must be especially careful.
6. When driving, it is necessary to grasp direction handles with both hands and step on the left and right main pedals ; the passenger should hold the handrail or hug the waist of the drivers and step on the left and right auxiliary pedals with both feet.
7. Besides looking front, left and right sides, the driver must observe the road surface conditions through left and right rear mirrors.

(2) Safety Protection Equipment

1. The injury and death accidents of the motorcycle drivers and passengers are mostly caused by head injuries. To protect your safety, it is necessary to wear high-quality crash helmet, dust-proof goggles, gloves and other protective products when driving ; the passengers should also be equipped as said.
2. During driving, the temperature of the silencer is very high and the driver and the passenger must wear high-quality leather clothing and boots against scalding.
3. Do not wear loose clothing and clothing with lacework in case the clothing is hooked by the controlling handles, pedals or wheels. Or such clothing may be hooked to the other vehicles by wind and cause accidents.

It must bear in mind that the high-quality protective equipment is only for prevention and never ignore traffic safety rules and regulations for wearing such protective equipment.

The excellent motorcycle driver is always: the one drives the motorcycle prudently.

Notes:

1、 Vehicle retrofitting or replacement of the original vehicle at will cannot ensure driving safety of the motorcycle and is illegal. The users must observe the use rules of the traffic administration department.

2、 To ensure that emission of the vehicle meets National Phase III Standards, the users should not retrofit or disassemble the following parts without authorization. Otherwise, the company will not be responsible for resultant consequences.

①. The silencer of the vehicle is installed with the optimized catalyst. If the silencer is damaged, please send it to the “CFMOTO Repair Station” for repair or replacement. Do not repair it yourself or purchase products of other manufacturers for replacement;

②. Carbon canister is the core part of the fuel evaporation recovery system and should not be disassembled without authorization.

2、 If you have good suggestions for retrofitting, please inform the company. The company will be responsible for implementation after confirmation. Any change to the vehicle at will may result in adverse consequence. If suggestion is not taken, the user shall be responsible for all consequences.

**(3) Vehicle Retrofitting
Warning**

1. The user cannot retrofit or change the vehicle circuit and other electric equipment on their own.

Otherwise, the electric system of the vehicle will be overloaded, which results in melting of the fuse or short circuit or even spark and car burning and other dangers.

2. The company will not be responsible for any consequence due to retrofitting or change of the vehicle circuit and other electrical equipment (including increase of the electric power) by the users.

(4) Loading of the Goods

Note:

The motorcycle has certain requirements for distribution of the load capacity. If the loading of goods is improper, the performance of the vehicle will be damaged and driving stability of the vehicle will be affected.

When loading the goods:

1. The center of the weight of the goods (center of gravity) should be at the lower part and close to the center of the vehicle.
2. Adjust the tire pressure according to the load and driving road conditions (Refer to page 21) .
3. All goods must be fixed on the vehicle tightly to ensure stable operation.
4. Do not attach large-scale and heavy articles to the steering handles, front shock absorber or front fender, otherwise driving is unstable or the steering doesn't work.
5. The maximum load requirements (150kg) of the vehicle should not be exceeded.

(5) Accessories

All accessories in the packaging box of the motorcycle are manufactured by the factory with special design and production and have been tested on the motorcycle. Because our company cannot carry out tests of products manufactured by other factories, the company will not be responsible for the accessories of other manufacturers installed and used by you.

After installation of the accessories, the users should carefully inspect whether the accessories have visual barrier, whether the road clearance or the side tilt angle are reduced, whether the control mechanism has good steering capacity and whether the operation is restricted. If such problems exist, use the vehicle after removing the accessories.

5. Operation Instruction

(1) Location of Parts

1. Left Side View (Figure1):

- ① Headlight, LH
- ② Left rear view mirror
- ③ Front turn signal, LH
- ④ Engine number
(on the right side)
- ⑤ Shift arm
- ⑥ LH pedal, Driver
- ⑦ Air filter
(Inside left side cover)
- ⑧ Side stand
- ⑨ LH pedal, Passenger
- ⑩ Front turn signal, RH
- ⑪ Rear handrail
- ⑫ Rear license lamp

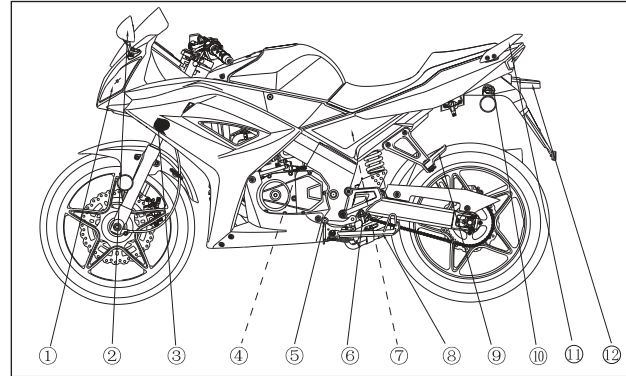

Figure 1 Left side view

2. Right Side View (Figure 2):

- ① Taillight/brake light
- ② Rear turn signal, RH
- ③ Muffler
- ④ Rear brake caliper
- ⑤ RH pedal, Passenger
- ⑥ Rear shock absorber
- ⑦ RH pedal, Driver
- ⑧ Rear brake pedal
- ⑨ Carburetor
(Underneath the fuel tank)
- ⑩ Fuel tank cap
- ⑪ Front turn signal, RH
- ⑫ Front brake caliper
- ⑬ Battery (underneath
the seat cushion)
- ⑭ Seat
- ⑮ Name plate (underneath
the decoration plate)
- ⑯ VIN number
- ⑰ Rear view mirror, RH
- ⑱ Headlight, RH

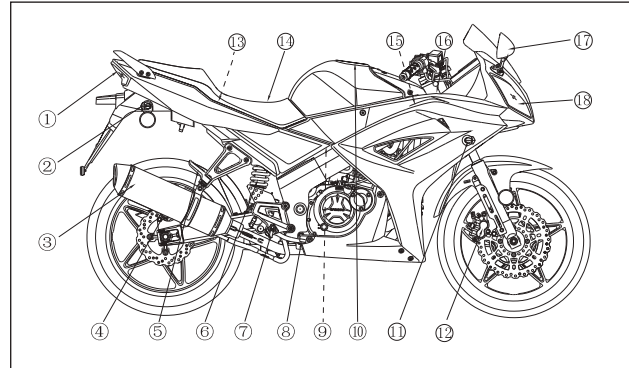

Figure 2 Right side view

3. Front Vehicle Part (Figure 3):

- ① Clutch lever
- ② Left handlebar switch set
- ③ Instrument
- ④ Ignition switch lock set
- ⑤ Right handlebar switch set
- ⑥ Front brake lever
- ⑦ Throttle handle

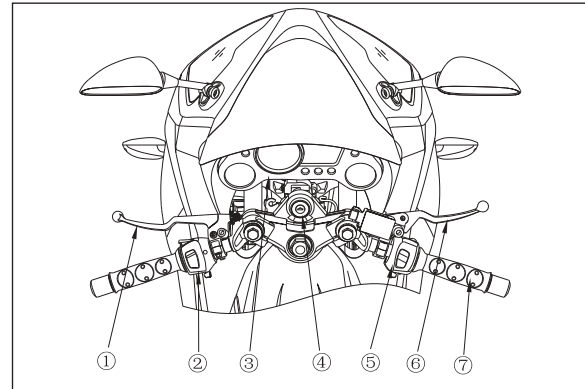

Figure 3 Front Vehicle part

4. Locations of the vehicle identification number (VIN) , name plate and engine serial number, (Figure 4)

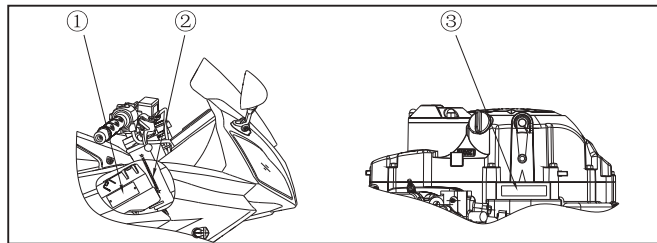

Figure 4 Vehicle identification number (VIN) , name plate and engine serial number

- ①Name plate : it is on the right side of the vehicle frame.
- ②Vehicle identification number (VIN) : it is on the right side of steering column;
- ③Engine serial number: it is on the right crankcase below the cylinder block;

(2)Instrument and Ignition Switch

[Instrument]

The following components are attached to the “Instrument” and the functions are as in Table 1 (Refer to Figure 5):

Table 1

S.N	Name	Functions
①	Left turn indicator light	Indicate the front and rear left turn light flash (the light is green)
②	Engine tachometer	Show the speed of the engine (RPM) .
③	Gear indicator	Show the specific gear of the engine (such as 1.2.3. 4.5.6)
④	Speedometer	Indicate the instaneous speed of the vehicle driving.
⑤	Battery power indicator	Turn on the ignition light and the light is on when the engine is without revolving speed; when the battery voltage is lower than 12 V, the light flashes.

S.N	Name	Functions
⑥	Right turn indicator light	Indicate the front and rear right turn light flash (the light is green)
⑦	Fuel level gauge	Show the quantity
⑧	Upper beam indicator	Indicate the upper beam is on (the light is blue)
⑨	Neutral gear indicator	It is neutral gear when the light is on (the light is green)
⑩	Failure indicator	When the vehicle circuit has failures, the light flashes and is on (the light is red,) if it is EFI model
(11)	Water thermometer indicator	When the water thermometer indicates “C” area, the water temperature is normal; when it indicates “H” red area, the water temperature is too high. It should immediately stop the engine and check the cooling system.
(12)	Odometer	Show the total mileage of the vehicle driving.

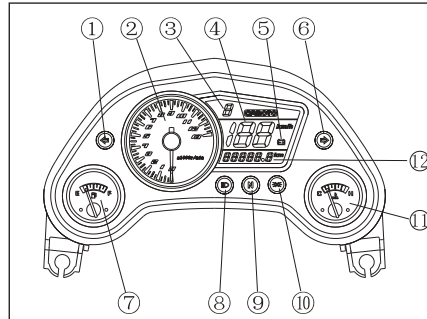





Figure 5 Instrument



[Ignition Switch]

“Ignition switch” setting is underneath the instrument (Refer to Figure 3). Turn on the ignition switch before starting the motorcycle. Refer to Table 2 for key location and functions:

Table 2

Key location	Functions	Key state
On “  ”	The entire circuit is disconnected, the engine cannot be started and the indicator lamp is off.	The key can be taken out
On “  ”	The entire circuit is closed and the engine can be started during neutral position.	The key cannot be taken out
Direction lock “  ”	The entire circuit is disconnected and the steering mechanism is locked.	The key can be taken out
Location lamp “  ”	The vehicle location light is on and the steering mechanism is locked.	The key can be taken out

Notes:

1. When the vehicle is not used, the ignition switch must be at the position of “” (when the user stops the vehicle, the ignition switch is at the position of “”. The position lamp still consumes power and it will result in insufficient or no power in the storage battery for long-term use.)
2. When stopping the vehicle and locking the direction, turn the steering handle to the left to the maximum extent, insert the key in the direction lock and turn 90° in counterclockwise to lock the steering mechanism (after turning it to “”, press the key downward to continue to turn it) and take out the key. If it needs to open the direction lock, insert the key in the direction keyhole and turn 90° in clockwise to open it and take out the key.
3. When the vehicle is stopped and not used, it is necessary to lock the steering mechanism.

(3) Right Handlebar Switch Set (Figure 6)

- ① Fire preset switch
- ② Illuminator and position lamp switch
- ③ Electric start-up button

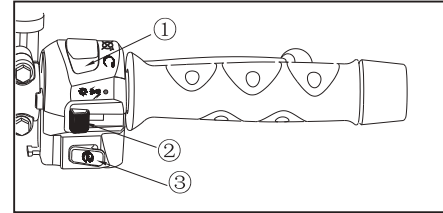







Figure 6 Right Handle Switch Set

[Flameout Preset Switch]

Flameout preset switch has two positions: “” and “”

“” position: indicate the entire circuit is disconnected, the engine cannot be started or the running engine is flameout.

“” position: Indicate the entire circuit is closed and the engine can be started.

Note: When starting the motorcycle, the switch must be at the position of “”.

[Electric Start-up Button]

The operation method: after completing start-up preparatory work, press the electric start-up button (🔌) and at the same time turn the throttle handle to throttle up the engine moderately to start the engine.

[Headlight, position lamp switch]

Headlight, position lamp switches have three positions: “●”、 “≡∩∩≡” and “☀” .

☀ position: headlight, instrument lamp and taillight are on.

≡∩∩≡ position: position lamp, instrument lamp and taillight are on.

● position: headlight, position lamp, instrument lamp and taillight are off.

(4) Left Handlebar Switch Set (Figure 7)

- ① Horn button
- ② Turn signal lamp switch
- ③ Headlight dimmer switch
- ④ Overtake light switch

[Overriding Light Switch]

After turning on the ignition switch, press the “overriding light button” and the “overriding light” is on; when releasing the switch, the button returns to the original position and the overriding light is not on.

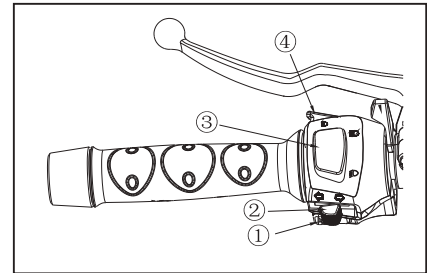





Figure 7 Left Handle Switch Set

[Headlight Dimmer Switch]

“Headlight dimmer switch” has total of two states. When turning on the “ignition switch” and the headlight, position lamp switches on the right handle switches are at the position of “” .

“Headlight dimmer switch” is at the state of lower beam when it is at the “” position and is at the state of upper beam when it is at the “” position.

[Horn Button]

After turning on the ignition switch: press and hold the “Horn button” , “Horn” continues to sound ; release the button, the button returns to the original position and the “Horns” stops sounding.

[Turn light Switch]

“Turn light switch” has three positions: “” (left), “” (right) and middle.

After turning on the ignition switch:

When it needs to turn left, switch the “turn light switch” to “” position ; the front and rear turn lights on the left side and the left steering indicator light in the instrument are on.

When it needs to turn right, switch the “turn light switch” to “” position ; the front and rear turn light on the right side and the right turn indicator light in the instrument are on ;

When the switch returns to the middle position ; the left and right turn light and indicator light are not on.

WARNING

When to make a turn or change the lane, it is necessary to turn on the turn light until complete turning or lane changing before turning off the turn light switch.

(5)Fuel and Fuel Tank Cover

[Fuel]

The fuel: 93# unleaded gasoline.

[Method for Opening the Fuel Tank Cap]

Insert the key into the fuel tank keyhole and turn the key clockwise to open the fuel tank lock ;

When it needs to be closed, align the latch on the fuel tank cap with the slot on the fuel tank hole neck, press it to the fuel tank hole neck to lock it and take out the key.

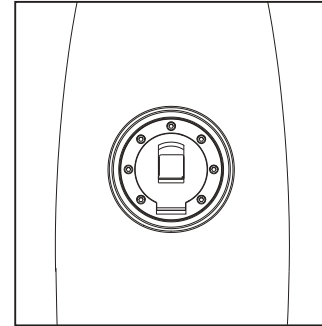

Figure 8 Fuel Tank Cap

Notes:

- 1.The fuel is inflammable, so filling the fuel in the ventilated area and the engine should be first shut down. It is strictly forbidden to smoke or produce other flame or spark.
- 2.Do not overfill the fuel (the fuel level should not reach the filler neck).
3. It is strictly forbidden to mix the fuel and lubricating oil in case the engine is damaged.

⚠ WARNING

To avoid exhaustion of fuel and accidental shutdown, when the pointer of the fuel level gauge on the instrument is close to E point, add fuel timely.

(6) Selection of engine oil

Lubricating oil is a key factor that affects the operation state and service life of the engine. So the engine oil that is suitable to the vehicle must be selected.

Table 3

SG or above level	SAE10W-30
	SAE15W-40
	SAE20W-50

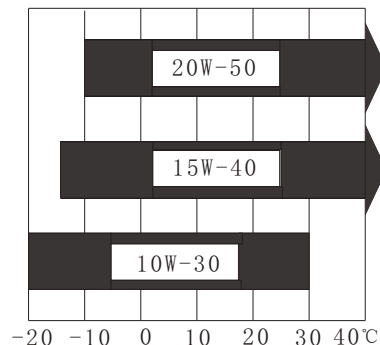

Figure 9 Engine Oil

⚠ WARNING

Application of poor quality engine oil will affect performance and service life of the motorcycle engine.

(7)Tire (Figure10)

Correct tire pressure will ensure: stable driving, comfortable driving and durable tire.

Check tire pressure when it is “cold tire” .

Tire specifications and tire pressure reference table 4 :

Table 4

Tire pressure under the cold state	Single person			Double person		
	kPa	kgf/cm ²	psi	kPa	kgf/cm ²	psi
Front wheel	175	1.75	25	175	1.75	25
Rear wheel	200	2.00	29	225	2.25	33
	Front wheel			Rear wheel		
Tire size	80/90-17 M/C 44S			110/80-17 M/C 57S		

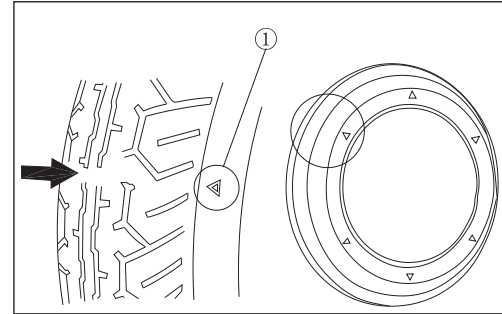

Figure10 Tire

It is very dangerous to use overworn tire and the traction, stability, steering and control will be affected. When the tread pattern in the middle of the tire reaches the minimum limit ①, it is necessary to change the tire. Before driving, it should check whether the tire has incision, nail or other sharp objects and whether the tire and rim are depressed or deformed.

Notes

1. Incorrect tire pressure may cause abnormal tread pattern wear and result in safety accident ;
2. Insufficient tire pressure may cause tire damage or separation from the rim.

6. Operation Guidance

(1) Run-in Period

Run-in period means in one stretch of road for the first use of the vehicle, such method is adopted to ensure best contacting between the parts.

Run-in period mileage of the new vehicle is: 1500 km.

Notes:

- ①. During run-in period, the throttle should not be fully open and the maximum rotating speed of the engine should not exceed 6500 RPM (refer to tachometer);
- ②. Each gear should be used;
- ③. Do not drive the vehicle with the fixed same throttle position;
- ④. Don't be overloaded (exceed the maximum loading)
- ⑤. Change engine oil three times.

Operation method in the run-in period:

1. 0 ~ 300km run-in:

The throttle handle should not exceed 1/2 of the maximum opening; vehicle speed is within 35km/h.

2. 300 ~ 600km run-in:

The throttle handle should not exceed 2/3 of the maximum opening; vehicle speed is within 45km/h.

3. 600 ~ 1500km run-in:

The throttle handle should not exceed 3/4 of the maximum opening; vehicle speed is within 55km/h.

[Change lubricating oil for three times during break-in period]

Change the lubricating oil for three times during break-in period within 1000km (one time for 300km, 600km and 1000km respectively); Later on, change one time after driving for about 1500km.

Quality requirements of the lubricating oil: SG grade or above

Notes:

1. The engine must be at warm condition before changing the lubricating oil.
2. If failure occurs to the engine during run-in period, please immediately consult with the CFMOTO repair station for inspection or repair.
3. After the run-in period, the user must ride the vehicle to the repair station for maintenance.

(2) Inspection before Driving

To ensure driving safety, please inspect the vehicle carefully before using the motorcycle ; if there is any abnormality during inspection, use the vehicle after troubleshooting.

Inspection can be carried out as follows:

1. Check the lubricating oil of the engine and ensure there is no leakage ;
2. Check whether the fuel is sufficient or not ;
3. Check the front and rear brakes: free play (front 10-20mm and rear 10-20mm) smooth operation ;
4. Check front and rear tires: the wear depth and cracks of the pressure and tread pattern ;
5. Check drive chains: whether it is appropriately fitted (top-bottom clearance 10-20mm) and whether the lubricating condition is good ;
6. Check throttle handle: free clearance (2-6 mm) and whether it is easy for throttle up or down ;
7. Check headlight and signal light: Ensure that the headlight, taillight, brake light, turn indicator light and the horn are in good state ;
8. Check electrolyte of the battery and timely add distilled water ;
9. Check steering device: it should be stable and flexibly rotated, free of looseness and axial drifting ;
10. Check clutch lever: free clearance (10-20mm) and smooth operation ;
11. Fastening: bolts and nuts of front and rear shock absorbers, fork, front and rear wheel shafts, engine suspension and steering systems, handle, front and rear brakes, clutches, rear suspension system, storage rack, electric components and so on.

(3) Start-up of Motorcycle (Figure11)

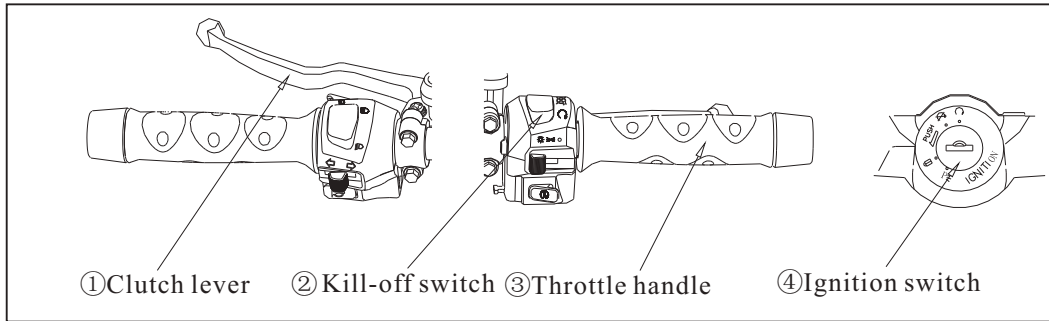





Figure11 Start-up Preparation



[Preparation for Start-up]

1. Turn on ④ignition switch. That is to turn the ignition switch to position of “” and switch the flameout switch to position of “” .
 2. Switch the gear position to the low speed or neutral gear .
 3. Completely grasp the ①clutch handle with the left hand (disconnect the clutch) .
- After completing the above 3 tasks, start-up preparation is completed.

[Start-up of Motorcycle]

After completing the “Start-up preparation” , press the electric button “  ” and then moderately throttle up the engine to start the engine.

Notes:

- 1. Warm up engine for (2-5 minutes) after start-up before road driving.**
- 2. When using the electric start-up button “  ” , release it within 3 ~ 5 seconds after running; Otherwise, service life of the storage battery will be affected due to fast discharge of the storage battery.**
- 3. After starting the engine, immediately release the electric start-up button “  ” ; during running of the engine, it is not allowed to press the electric start-up button “  ” again, otherwise the engine will be damaged.**
- 4. Ensure that the side stand is reset, preventing restriction to left turning and failure of control.**
- 5. After start-up or during driving, throttle up smoothly (turn the throttle handle) .**
- 6. Do not start the motorcycel in narrow space in case difficult emission diffusion causing danger.**
- 7. If the clutch switch fails, replace it timely.**
- 8. It is strictly forbidden to start the engine when clutch is not disconnected, otherwise parts will be damaged or safety accidents may occur.**

(4)Motorcycle Driving

[Shift Operation]

This vehicle is six-gear constant mesh; 1 and 2 gears are low speed and 3 gear is medium speed and 4, 5 and 6 gears are high-speed. Refer to the following operations for gear shifting:

When the engine is at idle speed, grasp the clutch lever with left hand to disconnect the clutch and step the front below shift arm to make the transmission enter ① gear.

1. Gradually increase rotating speed of the engine and slowly release the clutch lever, and coordinate such two actions to ensure smooth starting of the motorcycle.

2. After reaching smooth driving, reduce rotating speed of the engine, disconnect the clutch, uplift the shift arm with the left foot to make the transmission enter ② gear, then gradually increase rotating speed of the engine and slowly release the clutch lever and coordinate such two actions to ensure smooth driving.

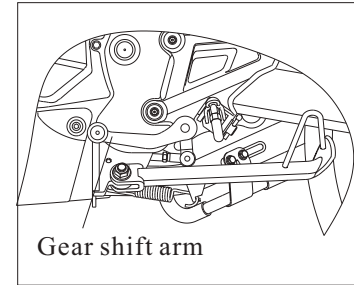

Figure 12 Shift position



Figure 13 Shift Schematic Diagram

- ③, ④, ⑤ and ⑥ gears shall be operated as per ② gear; if shift down is necessary, operate according to ① gear.
- When shifting the gear, please confirm that the shift arm is in place and then release the clutch.

WARNING

It is strictly forbidden to shift the gear without throttle down or grasping the clutch, otherwise the engine and the transmission system will be damaged.

[Climbing or turning]

- When the motorcycle is uphill, even if throttle up the engine, there is still deceleration due to insufficient power (because the gear is too high). Therefore, rapidly shift down (switch to the low speed gear) before climbing the slope, preventing from clutch slipping due to fast slow-down.
- When making a turn, there will be clutch slipping due to fast slow-down for abrupt throttle down. When making a turn or throttling down, shifting to the low speed gear, and then first use the brake to slow down the vehicle.

[Braking]

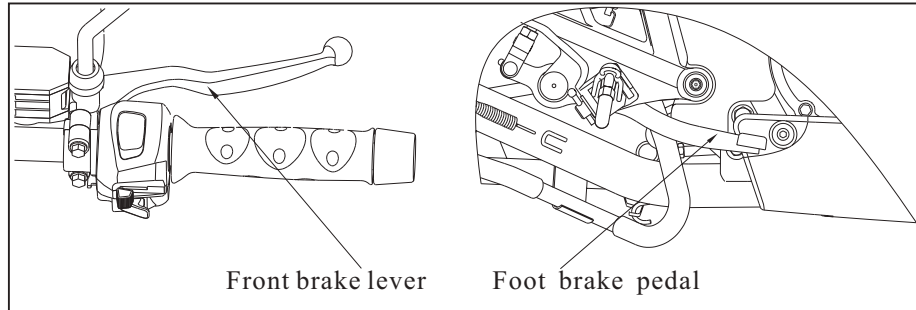



Figure14 Brake Position

1. When slow down is necessary, use front and rear brakes (it should slowly grasp the front brake with hands and step the rear brakes with feet and avoid separation of applying front and rear brakes) to stop the vehicle.
2. In case of emergency, directly turn off the flameout switch and at the same time use the front and rear brakes to stop the vehicle.
3. Try to avoid emergency brake. Emergency brake will cause sudden stop of the front and rear wheels, making the vehicle hard to be controlled.
4. On the wet, sliding or soft road surface, avoid abrupt acceleration, emergency brake and abrupt turning. Prevent sideslipping, which will make the vehicle difficult to be controlled.
5. When driving down the long slope, use the front and rear brakes intermittently and switch to the low speed gear and use engine to slow down and brake the vehicle. It is because overbrake during longer downhill will cause heating of the brake pad and brake disc and reduce brake effect.

[Parking]

1. Gradually throttle down and slow down the vehicle;
2. Gently apply front and rear brakes to stop the vehicle smoothly.
3. Turn off the ignition switch (the switch is at the position of off “”); under emergency circumstances, one can directly press the flameout preset switch to shutdown the engine.
4. Then, support up the vehicle with the side stand.
5. Lock the direction lock in case of theft.

7.Maintenance and Service

(1)Maintenance Periodic Table

Carry out regular maintenance as per time and mileage specified in Table 5 and it is necessary to clean the motorcycle before such maintenance.

Table 5

Maintenance intervals Items	Maintenance intervals	Odometer km(Remarks ②)				Remarks
		1000km	4000km	8000km	12000km	
* Fuel tank and fuel line		Timely maintenance or replacement for damage or aging				Before application
*Throttle		I	I	I	I	Before application
* Cooling		Replace I time for every 2 years				Check before application
Air filter element	Remarks ①	Drive for 40h or 1000km/I; drive for 80h or 2000km/C; drive for 20000km/R				
Spark plug		Drive for 2000km or 80h/I; drive for 6000km/R				
Engine oil	For new vehicle, replace I time for 300, 600 and 1000 respectively and repalce I time for about 1500 km every time					
Engine oil filter	For new vehicle, replace I time for 300, 600 and 1000 respectively and repalce I time for about 1500 km every time					
Drive chain/sprocket	Remarks ①	Carry out I and L for 500Km				
* Brake lining		Carry out I and if necessary R for 1000Km				
** Brake oil		Replace I time for every 2 years				
** Front and rear brake systems	Remarks ③	I	I	I	I	Before application
* Switch		I	I	I	I	Before application
* Lights and horn		I	I	I	I	Before application
* Storage battery	Monthly	I	I	I	I	
Fuse or overload protector		I	I	I	I	
Connecting		I	I	I	I	
** Valve clearance	Remarks ③	At first: 20h or 200km/I; drive for every 2000km or 80h/I				
* Clutch		Drive for every 2000km or 80h/I				Before application
* Suspension system		I	I	I	I	
* Fastening of bolts and nuts		I	I	I	I	Before application
* Wheel		I	I	I	I	Before application
** Steering handlebar bearing	Remarks ③	I	I	I	I	
** Service of engine	Remarks ③	I	I	I	I	

Symbols in the above table: “I” is for periodic inspection, cleaning, adjustment, lubricating or replacement; “C” is for cleaning; “R” is for replacement; “L” means lubricating.

Item without *can be maintained by the user and CFMOTO Service Station or authorized local dealer. Item with I*shall be maintained by the staff of the CFMOTO Service Station or authorized local dealer; if the user has special tool, repair spare parts or service capacity, the user can carry out maintenance on its own.

Item with II**must be maintained by the staff of the CFMOTO Service Station or authorized local dealer for driving safety.

Remarks ①means that: when driving in dusty area, it is more necessary to shorten cleaning cycle.

Remarks ②means that: when the reading of the odometer exceeds the maximum number, the maintenance cycle shall still be repeatedly carried out according to the mileage in the maintenance cycle table.

Remarks ③means that: only the staff of CFMOTO Service Station or authorized local dealer can carry out repair and adjustment.

(2) Inspection and Replacement of the Lubricating Oil of the Engine

Function of lubricating oil to the engine: reduce friction, increase sealability, cool parts, clean parts, anti-rust and so on.

Lubricating oil with poor quality, long-term use and insufficient lubricating oil quantity and so on will accelerate engine parts wear and reduce engine service life; or even result in excess temperature of the engine, wear or burning of the clutch, reduced power, abnormal sound, burning of the lubricating oil and so on.

When selecting the lubricating oil: Refer to “Selection of Lubricating Oil” .

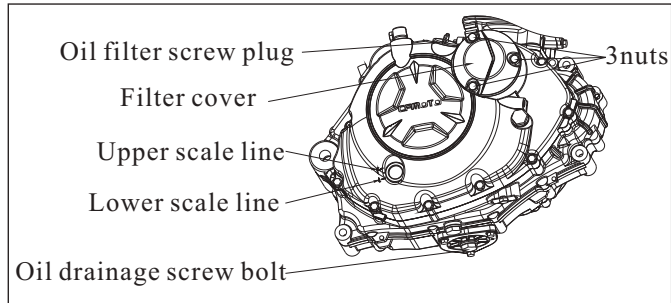

Figure15 Inspection of the Lubricating Oil

[Inspection of the Lubricating Oil]

Check the lubricating oil level before each application.

There is oil window on the right crankcase:

The oil surface should be at the scale line of the oil window(Figure14).

1. During inspection, the longitudinal plane should be perpendicular to the level ground.
2. When lubricating oil is insufficient, add moderate engine oil at SAE15W-40/SG grade or above until the scale line of the oil window.
3. Install the screw plug of the oil filler and check oil leakage.

WARNING

When the lubricating oil is insufficient, the engine will be seriously damaged.

[Change of Lubricating Oil]

- 1.For the new motorcycle purchased by the user, replace the lubricating oil according to the standard of “run-in period” .
- 2.The replacement cycle after run-in period is: every 1500 km.
- 3.Before change: Stop the engine after fully warming and then drain the lubricating oil of the engine (caution: do not be scalded by the hot engine or the lubricating oil).
- 4.During change: Place one empty oil box under the engine, unscrew the drainage bolt and unscrew 3 nuts to take out the filter cover, spring and element.
- 5.After oil drainage, it is necessary to clean the drainage bolt and oil filter cover; replace the machine oil filter element, check whether the sealing ring is good and replace it if it is damage; then install the filter screen, spring, sealing ring and machine oil filter cover.
6. Add about 1.2L new lubricating oil from the oil filler. If replace the oil filter element at the same time, it needs to add 1.25 Lunused lubricating oil and install the oil filler screw plug after leakage check.

3. Selection and Replacement of the Spark Plug

[Selection of the Spark Plug]

Spark plug model number: CR9EP

The user should use the original “CFMOTO” spark plug.

[Inspection and Replacement of the Spark Plug]

1. Replacement cycle of the spark plug is: every 6000 km.
2. Take down the spark plug cap, remove the dirt around it, dismantle the spark plug with the socket wrench in the tool bag and remove the carbon deposition and dirt in the spark plug with steel brush.
3. Check whether the spark plug is damaged, the electrode gaps is burned through and whether the sealing gasket is intact; if there is damage, replace it.
4. Use the feeler gauge to check the electrode gap the normal electrode gap should be 0.8~0.9mm.
5. When installing the spark plug: it is necessary to first set the screw thread on the spark plug and fasten it with the spark plug sleeve.

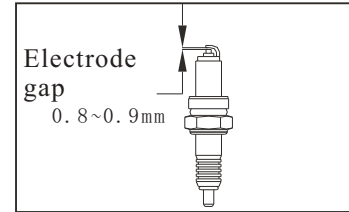

Figure16 Spark Plug

(4)Cleaning and Assembly of the Air Filter

1. The air filter element must be maintained regularly. If the motorcycle is operated under high temperature or in dusty environment, it is more necessary to shorten the cleaning or replacement cycle of the air filter element;
2. After driving for 2000km, clean the air filter one time at least. Carefully check the filter after driving for 1000km and clean the air filter element;
3. Replace the filter element when it is too dirty, broken or damaged. Maintain cleanness of the air filter can improve working efficiency of the engine and prolong the service life the engine ;
4. The motorcycle is foam filter element. The filter element can be cleaned by the non-flammable kerosene or cleaning solution ;
5. During dismantling: open the seat cushion, open the fuel tank, disassemble the upper cover of the air filter, then the fastening screw of the air filter and then take out the air filter;
6. Carry out assemble according to the opposite sequence of disassembling.

Notes:

Do not let water enter air filter element during vehicle cleaning, otherwise the start-up performance of the engine will be affected.

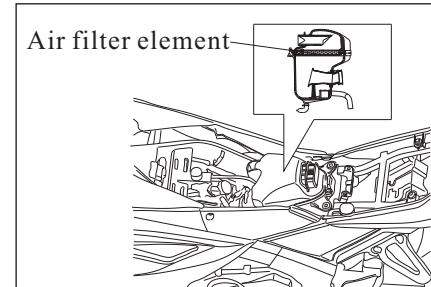

Figure17 Location of the Air Filter

(5) Inspection and Adjustment of the Throttle Handle

[Inspection of Throttle Control Line]

1. Check whether turning the throttle handle at full open to the position of full close is normal and whether the limit is reliable;
2. Check whether it is flexible to turn the throttle handle at full open to the position of full close;
3. Check whether the throttle control line between the throttle handle and the carburetor is good and flexible.

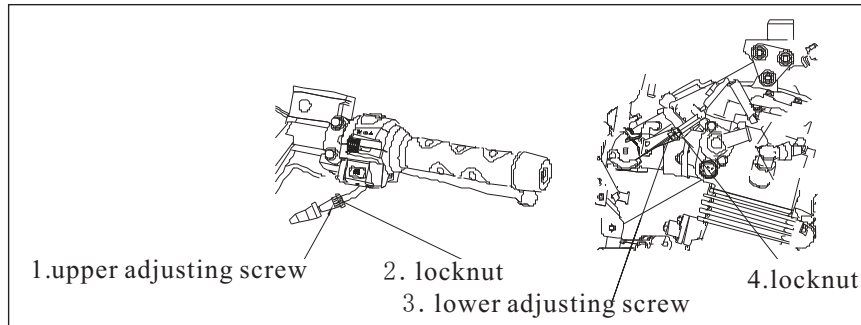

Figure18 Inspection of Throttle Control Line

[Throttle Lever Adjustment]

1. The free travel of the throttle lever is:2-6mm;
2. Carry out fine adjustment of the upper adjustment screw and adjust the lower adjusting screw to certain travel (joint between the throttle valve and the throttle cable);
3. During fine adjustment, first loosen the locknut② on the upper adjusting screw and then turn the upper adjusting screw ①for adjustment;
4. For large range adjustment, loosen the④locknut and adjust the free travel to 2-6mm.

Notes:

1. If the routing of the throttle control line is improper, re-install it correctly.
2. If the throttle control line is twisted off, restricted or cannot be returned, replace the control line.

[Carburetor adjustment]

Idle speed: 1500 ± 150 RPM (when at Neutral gear)

Notes:

Idle speed has been adjusted properly to best condition before delivery, our users don't need to adjust it. Otherwise emission will be affected.

WARNING

Idle speed cannot be adjusted, especially cannot be adjusted to less than 1300RPM to avoid engine fast damage due to insufficient oil supply to cylinder head.

(6)Clutch Adjustment

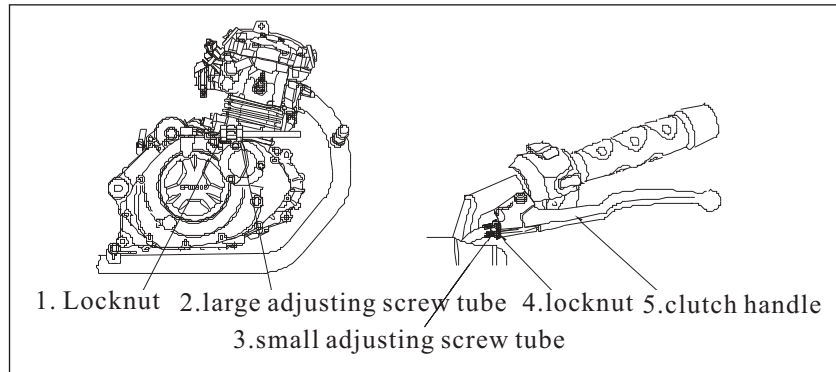

Figure19 Check of the Clutch Control Line

The clutch of the vehicle is manual operation, ⑤ Clutch handle:free travel:10 ~ 20mm.

Function of the clutch: Transmit the power of the engine to the transmission and disconnect the power transmission of the engine if necessary.

When using the clutch handle, the user should fully grasp or release it; avoid to half grasp or realse the clutch handle (semi clutch) as much as possible, otherwise the clutch will be worn or burned.

Figure18 The right Figure can carry out small range adjustment while the left Figure can carry out large range adjustment:

1. When the adjusting range is small: first loosen ④locknut, turn③the small adjusting screw tube. If the ③adjusting screw tube is turned as per clockwise, the free travel of the clutch will be increased; if turned as per counter-clockwise, the free travel of the clutch will be reduced.
2. When the adjusting range is large: first loosen the ①locknut of the clutch control line on the crankcase and then adjust②large adjusting screw tube. If the ②large adjusting screw tube is turned as per clockwise, the free travel of the clutch will be increased; if turned as per counter-clockwise, the free travel of the clutch will be reduced.

After adjusting the clutch, ride for a stretch of road and check whether the clutch will be disconnected.

Replace the clutch if it is overworn or burned; such replacement must be completed by “CFMOTO Repair station” .

Notes:

After your self adjustment, if the vehicle fails to reach ideal effect, please send it to the “CFMOTO Service Station or authorized local dealer” for adjustment.

(7) Inspection, Adjustment and Lubrication of the Drive Chains

[Inspection and Lubrication of the Drive Chains]

The drive chain includes many mutually operated parts and its service life depends on good lubrication and appropriate adjustment. Negligence of chain maintenance and service will result in premature wear of the chains and sprocket wheels. Therefore, regular chain maintenance is necessary.

If the drive chain, small and large sprocket wheels reach their wear limit, it is necessary to replace them.

The inspection procedure is as follows:

1. Switch to the neutral gear and the engine stops (take out the key);
2. Place the fingers on the ① drive chain and swing the chain up and down. The normal amplitude range is :between 10 ~ 20mm;
3. Check wear conditions of various chain links of the drive chain. If there is missing or damage or over wear or overlength of the chain link, replace such chain link;
4. Check wear conditions of the large and small sprocket wheels. If the wheel teeth are seriously worn, missing or broken, replace the wheels.

When lubricating:

1. Clean the drive chain, large and small sprocket wheels and add moderate engine oil to or spray lubricating oil on the cleaned drive chain, large and small sprocket wheels.
2. Clean and lubricate one time for driving 500km; in the dusty areas, increase such maintenance frequency.

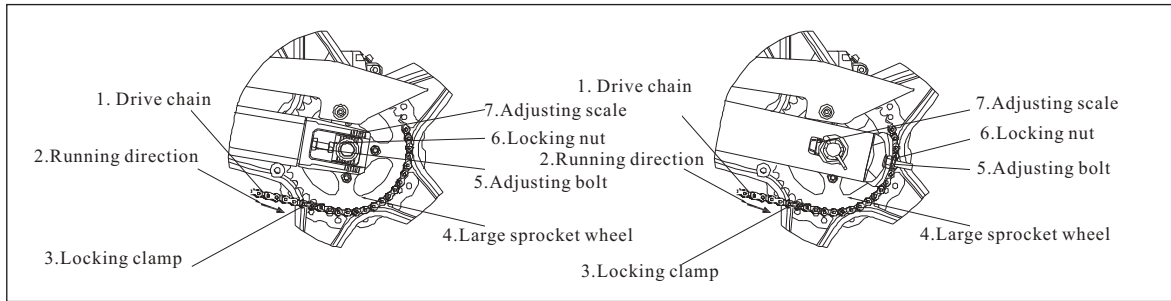

Figure20 Inspection of the Drive Chains

[Adjustment and Replacement of the Drive Chains]

When adjusting:

1. Parking the motorcycle with side stand or main process stand (matching), switch to the neutral gear and shut down the engine(take out the key).
2. Loosen the nuts of the rear axle and adjust the ⑤ adjusting nut with the same quantity; so that the chain has appropriate amplitude 10 ~ 20mm; the left and right adjusters at both sides should indicate the same ⑦ adjusting scale; check the tightness of the chain, then fasten the rear axle nut; fasten the ⑤ adjusting nut.

When changing:

1. Remove the drive chains ③ locking clamp with nipper plier carefully, take apart the chain link and take down the chain;
2. Disassemble the large and small sprocket wheels with tool;
3. Assemble the large, small sprocket wheels and drive chains in the opposite sequence of disassembling and adjust the free travel of the chains;
4. When installing the locking clamp, it is necessary to make the open end opposite to the ② running direction of the chains.

(8) Inspection and Adjustment of the Front Brake

[Inspection]

1. Support up the motorcycle with the side stand and the free travel of the front brake handle is measured to be: 10~30mm.
2. Check oil level in the oil cup; check whether the brake caliper is normal; check whether the brake oil pipeline and the brake oil cup are leaking or have cracks; check wear conditions of the brake disc.
3. When operating the brake handle, if it feels of insufficient handle pressure, there is air in the braking system; it is necessary to exhaust air in the braking system before use; otherwise the braking performance will be reduced or brake will be failed. This task shall be completed in “CFMOTO Repair Station” .

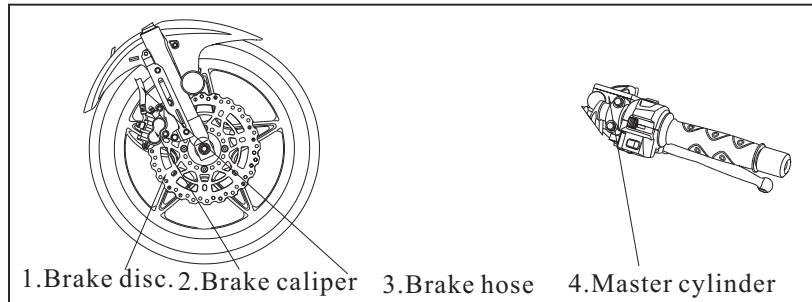

Figure21 Inspection of the Front Brake

[Replacement of Brake Disc and Brake pad]

1. When the limit wear thickness of the brake disc reaches 3 mm, it is necessary to replace it;
2. When the limit wear thickness of the brake pad reaches 1.5mm, it is necessary to replace it;
3. When repalcing the brake disc: it needs to take out the brake caliper, front wheel and dismantle the connecting nuts with the front wheel before replacement;
4. When repalcing the brake pad: Dismantle the brake caliper and loosen the external brake pad spring on the brake caliper before replacement;
5. Do not drive the motorcycle immediately after replacement of new brake disc or brake pad; it is necessary to control (grasp and release) several times of front brake lever until the brake disc and the brake caliper are well engaged.

[Front Brake Light Switch]

1. The front brake switch is installed at the connection between the front brake lever and the ④ brake pump.
2. When grasping the front brake lever, the front brake is switched on and the brake light is on; when releasing the front brake lever, the brake light is off.
3. Replace the switch when it is damaged.

WARNING

- 1. Add: DOT3 or DOT4 non-petroleum base brake fluid; do not mix use products with different brands;**
- 2. The brake fluid is highly corrosive. Do not splash it to the surface of the painted or plastic parts; if it is swallowed by accident, force him or her to spit it out; if it touches the eye or skin, flush it with large amount of water and seek medical advice;**
- 3. The hydraulic disc brake works under high pressure. To ensure safety and reliability, the replacement time of the brake pad and the brake fluid shall not exceed the maintenance intervals;**
- 4. When the hydraulic disc brake system needs to be repaired, it can only be repaired by the staff of “CFMOTO Service Station or authorized local dealer” .**

(9) Inspection and Adjustment of the Rear Brake

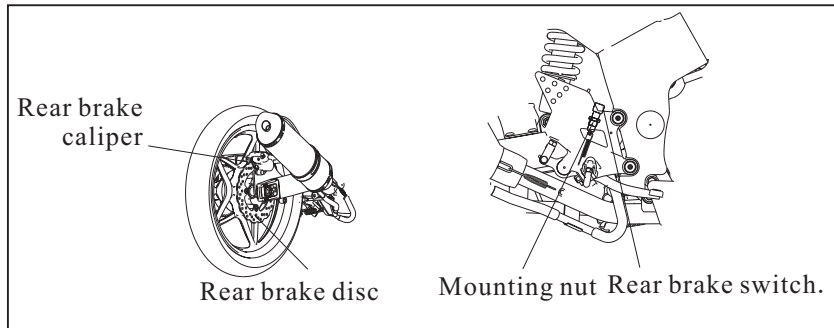

Figure22 Rear Brake Inspection

[Inspection]

During inspection: support up the motorcycle with the side stand and the free travel of the brake pedal is measured to be:10~30mm.

1. Measure thickness of brake pad in the rear brake pad.
2. Measure thickness of brake disc.
3. Check the fluid level of the fluid cup; Check whether the brake caliper is normal; check whether the brake hose and the brake fluid cup are leaking or have cracks; check wear conditions of the brake disc.
4. When operating the brake pedal, if the pedal pressure is insufficient, there must be air in the braking system; use the brake pedal after completely exhausting the air; otherwise, the braking performance will be reduced or the braking will be failed. This task shall be completed by the “CFMOTO Service Station or authorized local dealer” .

[Adjustment and Replacement]

1. It is necessary to replace the brake pad, when limit wear thickness reaches 1.5mm.

2. It is necessary to replace the brake disc, when limit wear thickness reaches 3 mm;

When replacing the brake disc, it is necessary to dismantle the drive chain, rear axle nut and rear axle, rear brake positioning nut and rear wheel and take out the rear brake for replacement. This task shall be done in the “CFMOTO Service Station or authorized local dealer” .

WARNING

1. After adjusting the rear brake system, it is necessary to commission and inspect the vehicle;

2. Step on the rear brake pedal several times, release the brake pedal and rotate the rear wheel to check whether it can rotate flexibly.

3. After adjusting the rear brake system, confirm that the brake pedal returns flexibly and braking force is normal;

4. If adjustment is not in place, please send it to the “CFMOTO Service Station or authorized local dealer” for adjustment.

[Adjustment of Rear Brake Lights]

Installation of the rear brake light switch: inside the right rear pedal side stand of the engine (refer to Figure21 of Page 43).

Adjustment method: it turns on too late, turn the mounting nut in counterclockwise.

If it turns on too early, turn the mounting nut in clockwise direction.

(10)Maintenance of Battery

Notes

The user must ensure the storage battery is fully charged, otherwise the battery will be damaged. It is necessary to check the voltage of the battery with the voltmeter every week if you do not use the vehicle frequently. If the voltage of the battery is lower than 12.8V, it is necessary to charge the battery with the charger (consult with the CFMOTO Service Station or authorized local dealer). If the motorcycle is not used for over two weeks, it is necessary to charge the battery with the charger. Do not use automatic quick charger to charge the battery, otherwise the battery will be overloaded or damaged.

Charger

Contact the dealer for detailed description of the battery.

Charging the battery

- Dismantle the battery from the vehicle (refer to dismantling of the battery)
 - Connect the charger lead and ensure that the charging current is 1/10A of the storage battery capacity,for example: given capacity is: For 10Ah storage battery, the charging current is 1Ah.
- When the storage battery is installed on the vehicle, ensure the power of the storage battery is full.
(refer to installation of the storage battery)

Battery :

- ① Negative electrode of the battery
- ② Positive electrode of the battery

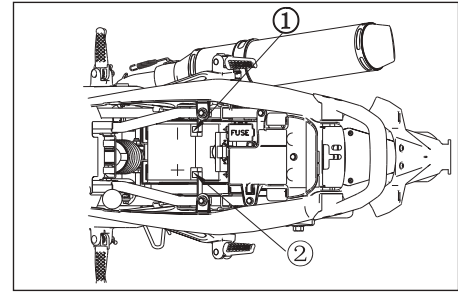

Figure 23 Position of the Battery

⚠ WARNING

It is forbidden to tear down the seal of the battery, otherwise the battery will be damaged. Do not install general battery on this vehicle, otherwise, the electric system do not work properly.

- 1. During charging, the battery will produce inflammable gases. It is necessary to be away from spark, naked flame and cigarette end and the battery should also ensure the environment is sufficiently ventilated during charging.**
- 2. There is sulfuric acid in the battery. If the skin or eye accidentally touches the electrolyte, severe burn can be caused. Therefore, please wear protective clothing and goggles for operation.**
- 3. If the skin or eye accidentally touches the electrolyte, wash it with water and seek medical advice immediately.**
- 4. Electrolyte belongs to toxic chemicals. If the electrolyte is swallowed accidentally, drink a large amount of water or milk, then drink magnesium oxide emulsion or vegetable oil and seek medical advice immediately.**
- 5. It is necessary to store the storage battery where the kids cannot reach.**

[Battery Model Number]

The Battery Model Number of the vehicle is: YTX7L-BS , the capacity is: 12V 6Ah. It is under the seat. The vehicle is equipped with maintenance-free battery, so it is not necessary to inspect the electrolyte quantity or add distilled water. Once the electrolyte is poured into the storage battery, the seal cannot be taken down. However, to ensure the best service life of the storage battery, it is necessary to charge the storage battery appropriately to ensure sufficient power for starting the motor. When the motorcycle is used frequently, the charging system of the motorcycle will charge the storage battery automatically. If the motorcycle is used occasionally or for a short period, the battery power is insufficient. The storage battery will produce self-discharge, the discharge speed of which varies according to type of the battery and environmental temperature.

[Inspection and Maintenance of the Battery]

When the motorcycle is not used for a long time, it is necessary to take down the storage battery from the motorcycle for storage and regularly charge the battery;

When dismantling, first dismantle the lead of negative electrode \ominus

It is necessary to clean the terminals of positive electrode \oplus and negative electrode \ominus of the battery on a regular basis. When installing, first install the lead of the positive electrode \oplus and then the lead of the negative electrode \ominus and ensure that the terminals of the positive and negative electrodes are tight; the positive and negative electrodes cannot be reversely connected.

When replacing the battery, it is necessary to use the battery with the same model number and specification.

[Fuse Replacement]

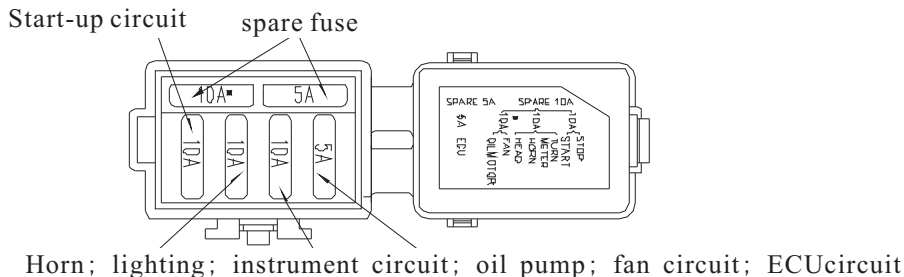

Figure24 Fuse Box

The rated current of the starting relay fuse is 20A and It is on the starting relay behind the battery. There is one spare fuse below the rubber sheath of the Starting relay ; The fuse box is in the front part underneath the seat cushion, The function is as shown in Figure 24. If the fuse is burned frequently, it means the circuit System is short or overloaded and it is necessary to send It to “CFMOTO Service Station” for repair. When replacing the fuse, dismantle the old fuse and install the new one and connect it.

⚠ WARNING

Before inspection or replacement of fuse, it is necessary to turn off the ignition switch and electric switches in case of short circuit.

Never use fuse that is inconsistent with the rated current, otherwise the electric system of the vehicle will be damaged or cause fire. Or during nighttime or driving, it might result in failed turning on of the lights or engine failure.

(11) Maintenance Instructions to Water-cooling System

[Cooling System]

The radiator is in the front of the engine. You should regularly remove dust and dirt from the radiator according to the conditions of the driving roads.

Coolant Type

It should only adopt high-quality ethylene glycol based and corrosion inhibitor-inclusive antifreeze agent, which is especially for aluminium engine.

The cooling system of the motorcycle includes 50% antifreeze agent and 50% water before delivery.

Notes:

It should only adopt high-quality ethylene glycol based and corrosion inhibitor-inclusive antifreeze agent, which is especially for aluminium engine.

The cooling system of the motorcycle includes 50% antifreeze agent and 50% water before delivery.

Check the Volume of the Coolant

1. Make the longitudinal plane of the motorcycle be perpendicular to the level ground during inspection;
2. Check level of the coolant when the engine is cooling down.
3. The coolant should be between the upper and lower scale lines.

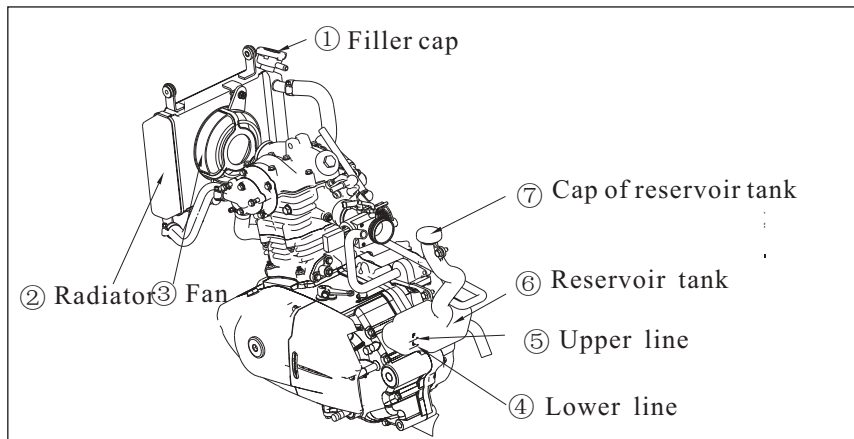

Figure26 Cooling System

Add a Few Coolant

If the coolant is at or lower than ④ lower line, Please add special coolant timely until reaching ⑤ Upper line
Adding procedures:

1. Make the longitudinal plane of the motorcycle be perpendicular to the level ground;
2. Dismantle the seat;
3. Open the ⑦ cap of reservoir tank in the Figure25, Add coolant until reaching ⑤ Upper line;
4. Install ⑦ cap of reservoir tank and seat.

Note:

If it needs to replace the coolant or there is leakage of coolant, please send it to the “CFMOTO Service Station or authorized local dealer” for replacement and repair.

(12) Vehicle Cleaning and Storage**[Vehicle Cleaning]**

Clean the motorcycle regularly in order to detect damage, wear or leakage problems timely. When cleaning, flush with clean water. After cleaning, wipe dry the motorcycle and start the engine to run for several minutes; lubricate the drive chain with the lubricating oil; before road driving, check brake and the front and rear brakes must be normal.

 WARNING

- 1. Parts cannot be cleaned by high pressure water: ignition switch, electric switch, instrument, electric parts, battery, air filter, wheel hub, exhaust pipe outlet, the lower part of the fuel tank and so on.**
- 2. After cleaning, the brake performance might be reduced. Thus, it is necessary to test the motorcycle and inspect it for adjustment and restoration before use.**

[Vehicle Storage]

After use, the user should store the motorcycle in dry, good-ventilated safe area with small temperature difference.

For long-term storage (over 30 days), it is necessary to carry out indispensable repair before storing the motorcycle; otherwise, repair problems might be forgotten after storage.

For long-term storage (over 30 days), besides the above maintenance, it is necessary to implement the following:

1. Clean and dry the motorcycle and wax the whole painted surface;
2. Drain the fuel in the fuel tank and inject anti-rust agent inside the fuel tank;
3. Take down the spark plug and inject a few lubricating oil(15 ~ 20 ml)to the cylinder;and then install the spark plug;
4. Dismantle the spark plug and store it in good-ventilated, dry, cool area without direct sunlight;
5. Inflate the tire until reaching specified pressure and place the motorcycle on the cushion block to make the front and rear wheels get off the ground;
6. Cover the motorcycle with the strong air permeable material and store it in dry, good-ventilated safe area with small temperature difference.

[Vehicle Use after Storage]

1. Take down the motorcycle covering and clean the motorcycle.
2. Check voltage of the storage battery. If the voltage is below 12.8V, carry out low-speed charging to supplement the battery power and then install storage battery.
3. Remove the anti-rust agent inside the fuel tank and add fresh fuel.
4. Try to ride the motorcycle in the safety place and check whether the motorcycle performance is normal.

(13) Vehicle Service Life and Vehicle Handling

[Vehicle Service Life]

For vehicle service life, implement according to the regulations of the traffic administration department or local vehicle administration station.

[Vehicle Handling]

1. Handling of waste lubricating oil: the waste lubricating oil repaced by the motorcycle should be stored in the plastic cask and submitted to the company for handling. The user cannot discharge the waste lubricating oil at will, otherwise, site, soil, water source and so on will be damaged.
2. Handling of the waste storage battery, bulb, appearance parts, filter element, tire, iron parts, alumnium parts and so on: these scrapped parts shall be classified into the waste bin as the waste. The user should not discard such waste at will and cannot discard the dilute sulphuric acid of the storage battery, which will cause injury to people or pollution to environment.
3. After scrapping, handle the vehicle according to the regulations of the traffic administration department or local vehicle administration station.

(14) Relevant Adjustment Data of Motorcycle

Free travel of the front (hand) brake 10-30mm

Free travel of the rear (foot) brake 10-30mm

Chain looseness: 10-20mm

Intake and exhaust valve clearance: 0.10-0.15 mm

Torque rating of the clamp nut of the rear shock absorber: 35-45 N. m

Torque rating of the clamp bolt of the handle : 10-14N. m

Torque rating of the clamp nut of the fork: 50-80 N. m

Torque rating of the clamp nut of the front axle: 50-80N. m

Torque rating of the clamp nut of the steering system : 60-90 N. m

Torque rating of the clamp nut the rear axle: 50-80 N. m

Torque rating of the clamp bolt of the front shock absorber and upper connecting plate: 10-14N. m

Torque rating of the clamp bolt of the front shock absorber and direction column: 20-25 N. m

Torque rating of the clamp nut of engine suspension: M8: 20-30 N. m, M10: 34-40 N. m

Free clearance of the throttle handle: 2-6mm

Free travel of the clutch: 10-20mm

Spark plug gap: 0.8-0.9 mm

(15)CF150-2C Main Technical Parameters Table

	Vehicle Model(Items)	CF150-2C(Specifications)
Complete vehicle parameters	Manufacturer name	Zhejiang CFMOTO Power Co.,Ltd.
	Vehicle model number	CF150-2C
	Implementation standard	Q/CFD 013-2011
	Vehicle brand	CFMOTO (CFMOTO)
	Vehicle type	General motorcycle
	Vehicle identification number	LCEPDKL8××××××××
	Approved passenger capacity	2 persons (1 driver and 1 passenger)
	Steering form	Handlebar
	Gear form	6 gear constant mesh
	Brake form	Front wheel:disc Rear wheel:disc
	Brake operation method	Front wheel:Hand braking Rear wheel:Pedal braking
	Clutch form	Wet (oil-immersed) multiple-disc
	Clutch operation method	Manual operation
	Start-up method	Pure electric start-up
	Length×width×height	1920×705×1100 (mm)
	Wheel base	1310 (mm)
	Minimum ground clearance	200 (mm)
	Complete vehicle kerb mass	138kg
Maximum load quality	150kg	
Fuel tank capacity	12.5 (L)	
Number of tires	2	
Front wheel specification	80/90-17 M/C 44S	
Rear wheel specification	110/80-17 M/C 57S	

Vehicle Model(Items)		CF150-2C(Specifications)
Electric device	Ignition method Spark plug model number Headlight specification Turn light specifications Taillight /brake light specification Fuse specification Battery specification	CDI CR9EP 12V35W/35W LED LED 20 A (1) , 10A (3) and 5A (1) YTX7L-BS 12V 6Ah
Engine	Engine type Engine model Compression ratio Cylinder volume Max. net power Max.torque Cylinder bore×travel Idle speed Brand of engine lubricating oil Lubricating oil capacity Fuel brand Spark plug gap	Vertical,single-cylinder, 4 stroke, liquid cooled 157MJ-3A-(A1) 10.5: 1 149.4ml 10.5kW/9000rpm 12.2N • m/6500rpm 57×58.6 1500±150 rpm SAE15W-40/SG Replacement:1.2 overhaul:1.4L 93# 0.8~0.9 mm

Vehicle Model(Items)		CF150-2C(Specifications)
Gear ratio	Primary ratio	3.5
	1 gear ratio	3
	2 gear ratio	1.857
	3 gear ratio	1.368
	4 gear ratio	1.143
	5 gear ratio	0.957
	6 lgear ratio	0.875
	Final ratio	2.867
Performance	Max.vehicle speed	100km/h
	Gradeability	≥20°
	Fuel consumption	≤2.9L/100km

(16) WIRING DIAGRAM (CF150-2C)

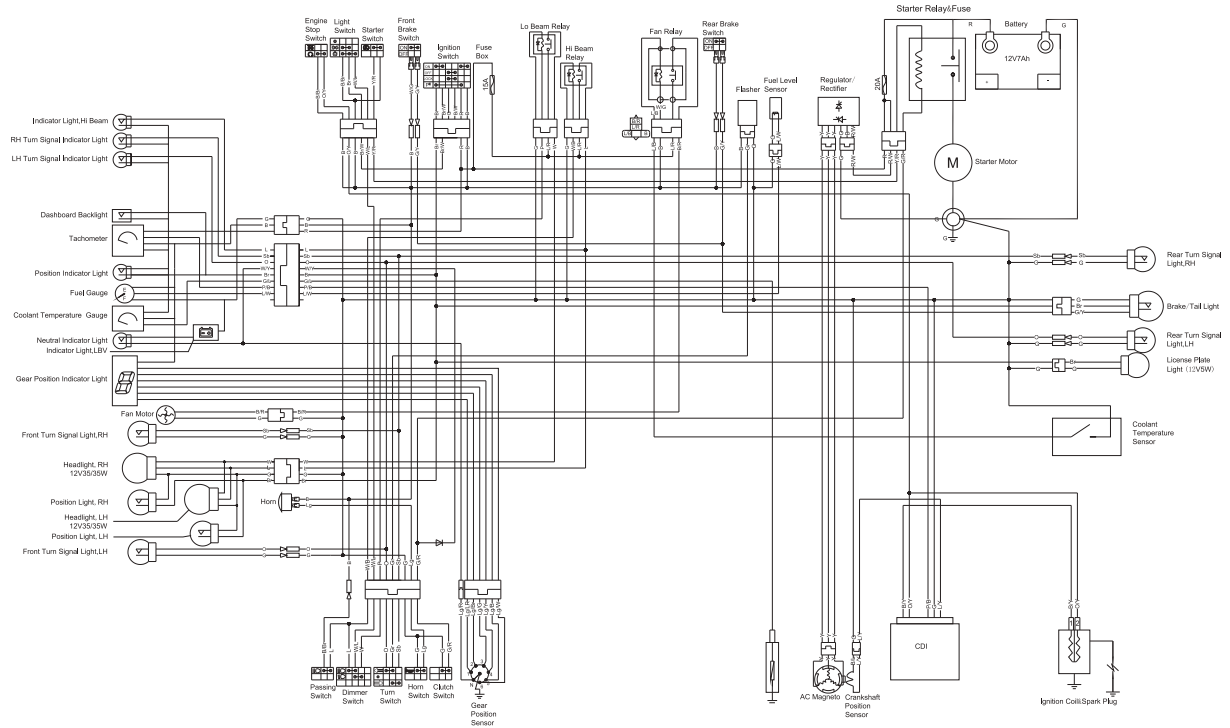

R-Red	B-Black	G-Green	Y-Yellow	L-Blue	W-White	Lg-Light green
Gr-Grey	Br-Brown	O-Orange	P-Purple	LR-Pink	Sb-Sky blue	

(17) Common Failure and Cause of the Motorcycle

Problems	Part location	Troubleshooting	Solutions
Fail to be started	Fuel system	No fuel in the fuel tank	Fueling
		Fuel switch and strainer are blocked or worn: poor fuel quality	Cleaning or replacement
		Fuel hose blocked or poor fuel quality	Cleaning or replacement
		Intake air pipe leakage or overused for long time	Adjustment or replacement
		Carburetor needle valve blocked or poor quality fuel	Cleaning or replacement
	Ignition system	Spark plug failure: too many carbon deposits and long-term use	Inspection or replacement
		Spark plug cap failure: poor contact or burned	Inspection or replacement
		Ignition coil failure: poor contact or burned	Inspection or replacement
		CDI failure: poor contact or burned	Inspection or replacement
		Trigger coil failure: poor contact or burned	Inspection or replacement
		Stator failure: poor contact or burned	Inspection or replacement
	Cylinder pressure system	Cable failure: poor contact	Inspection or adjustment
		Start-up mechanism failure: worn or damaged	Inspection or replacement
		Failure of intake and exhaust valves and valve seat: too much fuel colloidal or long-term use	Inspection or replacement
Failure of cylinder, piston and piston ring: too much fuel colloidal or wear		Inspection or replacement	
Air leakage of the intake pipe: long-term use		Adjustment or replacement	
Insufficient power	Valve piston	Valve timing failure	Adjustment or replacement
	Clutch	Too much carbon deposit in the intake and exhaust valves and piston: poor fuel quality and poor engine oil	Repair or replacement
	Cylinder ring	Clutch slipping: poor engine oil, long-term use and overloaded	Adjustment or replacement
		Worn cylinder and piston ring: poor engine oil, long-term use	Replace engine oil

Problems	Part location	Troubleshooting	Solutions
Insufficient power	Brake	Brake is thoroughly separated : the brake is too tight	Adjustment
	Large chain	The drive chain is too tight: improper adjustment	Adjustment
	Engine	The engine is overheated: gas mixture is too thick or thin, poor engine oil and fuel quality, barrier and so on.	Adjustment or replacement
	Spark plug	Improper spark plug gap , normal range is 0.8-0.9 mm	Adjustment or replacement
	Intake pipe	Air leakage of intake pipe: long-term use	Adjustment or replacement
	Cylinder head	Air leakage of the cylinder head or air valve	inspection or replacement
	Electric system	There is failure in electric system	Inspection or repair
	Air filter	Blocked air filter	Cleaning or adjustment
Headlight and taillight do not work	Cable	Poor circuit contact	Adjustment
	Left and right switches	poor switch contact or the switch is damaged	Adjustment or replacement
	Headlamp	Bulb and lamp holder inspection	Adjustment or replacement
	Voltage regulator	Inspection of the voltage regulator : poor contact or burned	inspection or replacement
	Magneto	Magnetor coil inspection : poor contact or burned	inspection or replacement
Horn doesn' t work	Battery	No power in the battery	charging or replacement
	Left switch	Horn button inspection	Adjustment or replacement
	Cable	Poor circuit contact	Adjustment or repair
	Horn	Horn is damaged	Adjustment or replacement

The above listed are the common failures of the motorcycle. If there is any failure in your motorcycle, please contact “CFMOTO Service Station” timely for inspection and repair.

It should be noted that: Do not handle motorcycle failures at one's discretion, otherwise potential safety hazard or safety accident will be caused. The users shall be responsible for safety accidents due to failure handling at their own discretion.



ZHE JIANG CFMOTO POWER CO.,LTD.

Add: NO.116 Wuzhou Road, Yuhang Economic Development
Zone, Hangzhou, Zhejiang 311100, China

Tel: 0571-89265684 Fax:0571-89265696

Website: www.cfmoto.com