

GILERA WOULD LIKE TO THANK YOU

for choosing one of its products. We have prepared this manual to help you to get the very best from your scooter. Please read it carefully before riding the scooter for the first time. It contains information, tips and precautions for using your scooter. It also describes features, details and devices to assure you that you have made the right choice. We believe that if you follow our suggestions, you will soon get to know your new vehicle and it will serve you well for a long time to come. This booklet forms an integral part of the scooter; should the scooter be sold, it must be transferred to the new owner.

Runner ST 125 - 200



The instructions given in this manual are intended to provide a clear, simple guide to using your scooter; this booklet also details routine maintenance procedures and regular checks that should be carried out on the vehicle at an **authorised Dealer or Service Centre**. The booklet also contains instructions for simple repairs. Any operations not specifically described in this manual require the use of special tools and/or particular technical knowledge: to carry out these operations refer to any **authorised Dealer of Service Centres**.



Personal safety

Failure to completely observe these instructions will result in serious risk of personal injury.



Safeguarding the environment

Sections marked with this symbol indicate the correct use of the vehicle to prevent damaging the environment.



Vehicle intactness

The incomplete or non-observance of these regulations leads to the risk of serious damage to the vehicle and sometimes even the invalidity of the guarantee.

The signs that you see on this page are very important. They are used to highlight those parts of the booklet that should be read with particular care. As you can see, each sign consists of a different graphic symbol, making it quick and easy to locate the various topics.

INDEX

VEHICLE..... 7

- Dashboard..... 9
- Instruments..... 9
- Digital lcd display..... 10
 - Setting the total and trip odometers..... 10
 - Setting the hour/minutes function..... 11
- Key switch..... 12
 - Locking the steering wheel..... 12
 - Releasing the steering wheel..... 12
- Switch direction indicators..... 13
- Horn button..... 13
- Light switch..... 13
- Start-up button..... 14
- The immobilizer system..... 14
 - Keys..... 14
 - Immobilizerdevice enabled indicator led..... 15
 - Operation..... 15
 - Programming the immobilizer system..... 16
- Fuel tank..... 17
 - Opening the saddle..... 17
- Identification..... 18

USE..... 19

- Checks..... 20
- Refuelling..... 20
- Tyre pressure..... 21
- Running in..... 22
- Starting up the engine..... 23
- Difficult start up..... 24
- Stopping the engine..... 25
- Catalytic silencer..... 26
- Automatic transmission..... 26
- Safe driving..... 27
- Air conveyors..... 29

MAINTENANCE..... 31

- Engine oil level..... 32
 - Engine oil level check..... 32
 - Warning light (insufficient oil pressure)..... 32
 - Engine oil change..... 33
- Hub oil level..... 34
- Tyres..... 36
- Spark plug dismantlement..... 37
- Removing the air filter..... 38
- Secondary air system..... 39
- Cooling fluid level..... 39
- Checking the brake oil level..... 41
- Battery..... 43
 - Use of a new battery..... 43
- Long periods of inactivity..... 44
- Fuses..... 45
- Front light group..... 48
 - Headlight adjustment..... 48
- Front direction indicators..... 50
- Rear optical unit..... 50
- Rear turn indicators..... 51
- Number plate light..... 52
- Rear-view mirrors..... 52
- Idle adjustment..... 52
- Front and rear disc brake..... 53
- Puncture..... 54
- Periods of inactivity..... 55
- Cleaning the vehicle..... 55

TECHNICAL DATA..... 61

- Kit equipment..... 66

SPARE PARTS AND ACCESSORIES..... 67

- Warnings..... 68

PROGRAMMED MAINTENANCE..... 69

Scheduled maintenance table..... 70

Runner ST 125 - 200



GILERA®



**Chap. 01
Vehicle**

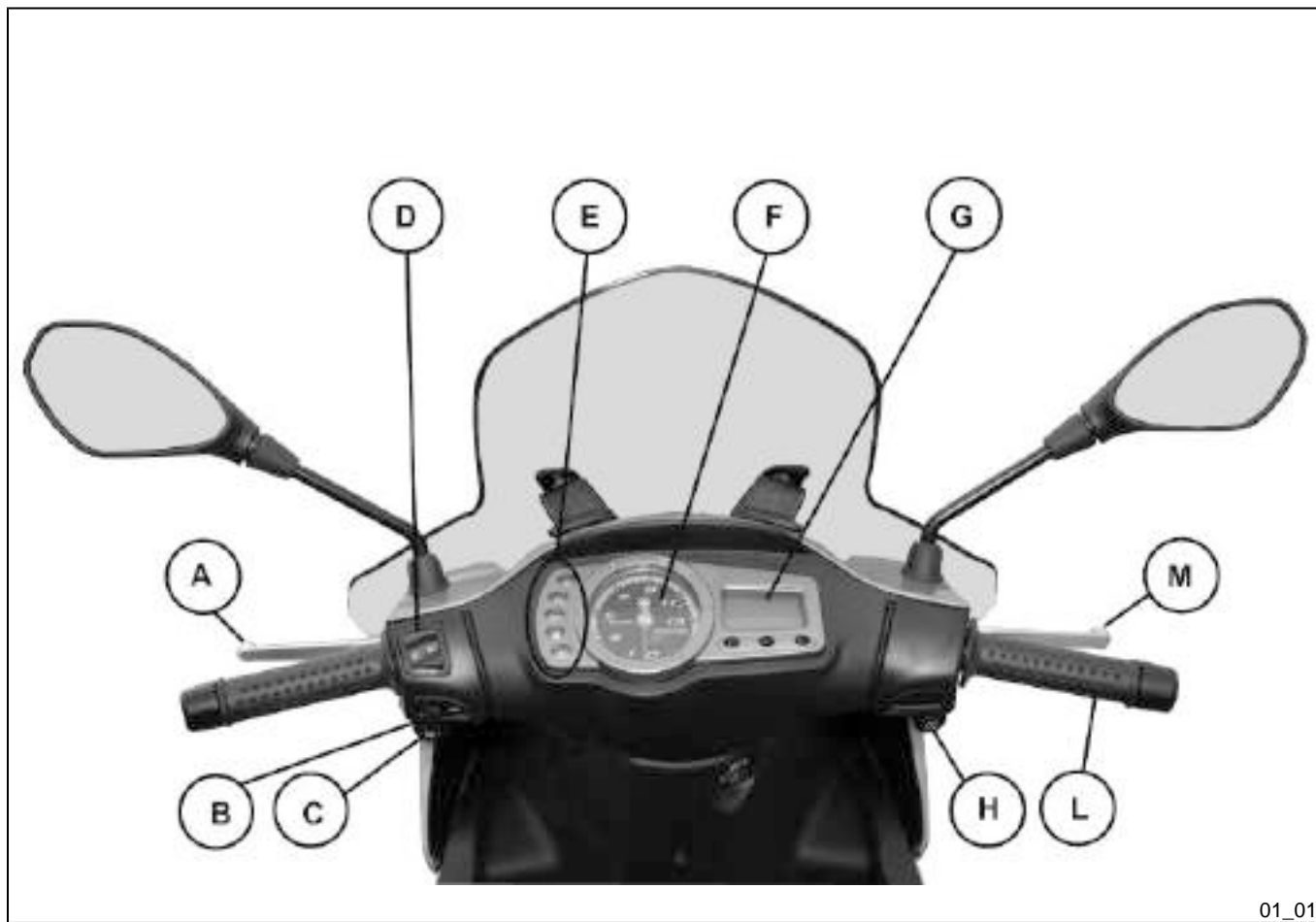

Dashboard (01_01)

- A = Rear brake control;
- B = Turn indicator switch;
- C = Horn button;
- D = Lights switch;
- E = Warning lights;
- F = Rpm indicator;
- G = Digital instrument panel;
- H = Start-up button;
- L = Throttle control;
- M = Front brake control;

Instruments (01_02)

- A= High-beam warning light;
- B= Engine oil pressure warning light;
- C= Turn indicator warning light;
- D= Low fuel warning light;
- E= Headlight warning lights;
- F= Rpm indicator;
- G= **"Mode"** Button;
- H= **"Clock"** Button;
- L= **"Set"** Button;
- M= Total/Trip Odometer;

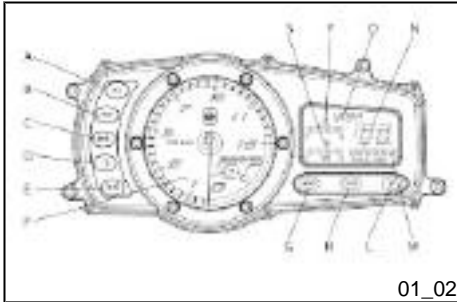

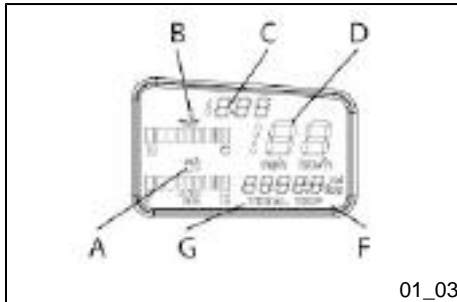

N= Speedometer;

O= Clock;

P= Coolant temperature gauge

S= Fuel gauge;

Digital lcd display (01_03)

A= Fuel level gauge;

B= Coolant temperature gauge;

C= Digital clock;

D= Speedometer;

E= Odometer;

F= Partial odometer gauge;

G= Total odometer gauge;

Setting the total and trip odometers

Pushing the "**MODE**" button for less than a second obtains, respectively, the functions of:

1. **TOTAL** - The word "**TOTAL**" appears and **Km/h** or **mph**. The value corresponds to the total distance travelled by the vehicle and it is not adjustable.
2. **PARTIAL**- The word "**TRIP**" appears and **Km/h** or **mph**. The value can be changed by pressing and holding the "**SET**" button for longer than three seconds.

N.B.

IT IS POSSIBLE TO CHANGE THE DISPLAY FROM KILOMETRES (km/h) TO MILES (mph) BY PRESSING THE "MODE" AND "CLOCK" BUTTONS AT THE SAME TIME AND HOLDING THEM FOR LONGER THAN THREE SECONDS AFTER PUTTING THE KEY SWITCH IN THE «ON» POSITION.

ON THE DISPLAY THE WORD "SET" WILL APPEAR FOR ONE SECOND

CAUTION



IT IS STRONGLY ADVISED NOT TO USE THE FUNCTIONS OF THE DIGITAL DISPLAY PANEL WHILE THE VEHICLE IS MOVING.

Setting the hour/minutes function

To set the clock push and hold the «**CLOCK**» button for longer than three seconds. The figures showing the hours start to flash.

Set the hours using the «**SET**» button.

Push the «**CLOCK**» button again and the minutes numbers start flashing.

Set the minutes using the «**SET**» button.

Press the «**CLOCK**» button again to start the clock moving normally.

During the reset process, not pressing any buttons for 8 seconds ends the process and the display will automatically show the modified time.

N.B.

WHEN THE TIME IS «P.M.» THE NUMBER "0" IS DISPLAYED AFTER THE NUMBER "11". WHEN THE TIME IS «A.M.» THE NUMBER «12» IS DISPLAYED.

CAUTION

THE «CLOCK» BUTTON IS ENABLED ONLY WHEN THE ENGINE IS OFF AND THE KEY IS TURNED TO «ON».



Key switch (01_04)

LOCK = Ignition disabled, extractable key, steering lock engaged, seat cannot be opened.

OFF = Ignition disabled, extractable key, steering lock disengaged, seat can be opened.

ON = Ignition enabled, antitheft protection disconnected, non-extractable key, seat can be opened.

To open the seat the key switch must be set to either the «**OFF**» or «**ON**» position.

Locking the steering wheel

Turn the handlebar to the left (as far as it will go), turn the key to position «**LOCK**» and remove the key.

CAUTION



DO NOT TURN THE KEY TO «LOCK» OR «OFF» WHILE RIDING.

Releasing the steering wheel

Reinsert the key and turn it to «**OFF**».

Switch direction indicators (01_05)

To set the left turn indicators flashing, move lever «**B**» to the left; to set the right turn indicators flashing, move it to the right. The lever automatically returns to the central position and the indicators remain on. To turn the indicators off, press the lever towards the switch.

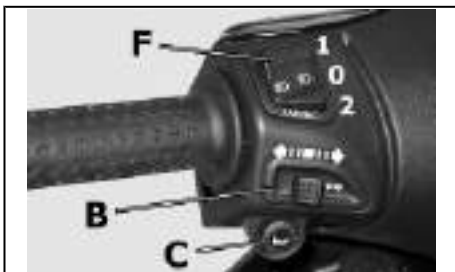

01_05

Horn button (01_06)

Push the «**C**» button to sound the horn.

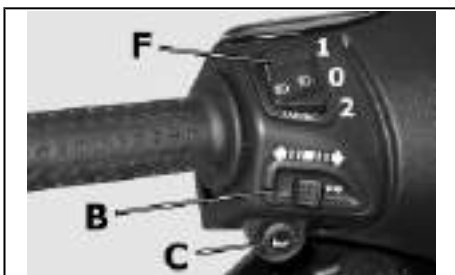

01_06

Light switch (01_07)

0 = Low-beam and taillight

1 = High-beam and taillight

2 = Passing (flashing)

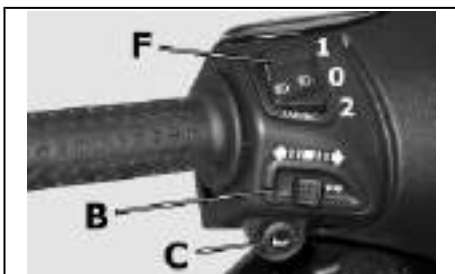

01_07



01_08

Start-up button (01_08)

Press the button «E» to start the engine, after pulling one of the two brake levers



01_09

The immobilizer system

In order to enhance theft protection, the scooter is equipped with a «PIAGGIO IMMOBILIZER » electronic engine locking device that is activated automatically when the starter key is removed. Upon start-up, the «PIAGGIO IMMOBILIZER» system checks the starter key, and only if this key is recognised will the immobilizer system allow the scooter to be started.

Keys (01_09, 01_10, 01_11)

Two types of keys come with the vehicle. The key «A» with a brown grip is the programming key. Only one is supplied and it serves to memorise the code of the other keys or to allow the dealers to take various measures. For this reason it is advised that it be used only in exceptional circumstances. The key «B», red in colour, is for normal use, and serves to:

- engine start up
- unlock the fuel tank cap

Together with the keys comes a CODE CARD which is imprinted with the mechanical code of the keys.

WARNING

THE LOSS OF THE BROWN KEY PREVENTS LATER REPAIRS TO THE "PIAGGIO IMMOBILIZER" SYSTEM AND TO THE ENGINE CONTROL UNIT.



01_10

WARNING

IT IS ADVISED THAT THE "CODE CARD" AND THE KEY WITH THE BROWN GRIP BE KEPT IN A SAFE PLACE (NOT ON THE VEHICLE).

Immobilizer device enabled indicator led (01_12)

The functioning of the «**PIAGGIO IMMOBILIZER**» system is shown by the flashing of the appropriate warning light «**F**», shown in the «**Dashboard**» section. In order to reduce battery discharge, the indicator LED turns off automatically after 48 hours of uninterrupted functioning. Should the signal led system break down in its flashing function, give information about the type of problem to an **Authorised Piaggio-Gilera Service Centre**.

Operation

Every time the starter key is removed in the "**OFF**" or "**LOCK**" position, the safety system activates the immobilizer system. Turning the key to "**ON**" disables the engine lock, provided that the safety system recognises the code transmitted by the key. If the code is not recognised, turn the key first to "**OFF**" and then "**ON**"; if the block remains try again with the other brown key. If it is still not possible to start the engine it is absolutely necessary to turn to an **Authorised Piaggio-Gilera Service Centre** that has the equipment necessary for diagnosis and repair of the system.

When additional keys are required, please note that data storage (up to 3 keys max.) must be done on all keys, both new ones and existing ones. Turn directly to an **Authorised Piaggio-Gilera Service Centre**, bringing the brown key and all the red ones. The codes of keys not submitted for the new storage procedure are deleted from the memory. Any lost keys will therefore not be enabled to start the engine.

WARNING**WARNING**

EACH KEY HAS ITS OWN AND UNIQUE CODE, WHICH MUST BE STORED BY THE SYSTEM CONTROL UNIT.

VIOLENT SHOCKS MAY AFFECT THE ELECTRONIC COMPONENTS OF THE KEY.



01_11

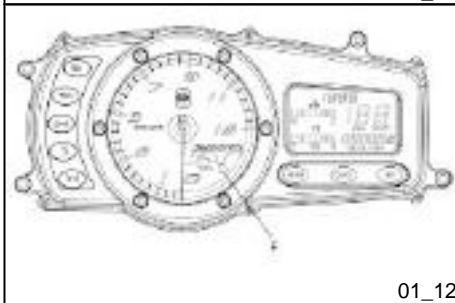

01_12

SHOULD THE VEHICLE CHANGE OWNERS, IT IS ABSOLUTELY NECESSARY THAT THE NEW OWNER GET POSSESSION OF THE KEY WITH THE BROWN GRIP (AS WELL AS ALL OTHER KEYS) AND THE «CODE CARD»

Programming the immobilizer system

In the following is described the procedure to follow to program the "PIAGGIO IMMOBILIZER" system and/or enter other keys in the memory.

Procedure start - brown key

Insert the brown key into the key switch (in the «OFF» position), turning it to the «ON» position. After 1 - 3 seconds, turn the key to «OFF » again and pull it out.

Intermediate step - red key

After extracting the brown key, insert the red key within ten seconds and turn it immediately to the «ON» position. After 1-3 seconds, turn the key to "OFF" again and pull it out. Repeating this procedure, respecting the indicated times, a maximum of three red keys can be programmed.

Final step - brown key

After extracting the last red key, insert the brown key again and turn it to the «ON» position (perform this within ten seconds of the extraction of the previous key). Leave it in this position for 1 to 3 seconds and return it to the «OFF» position.

Proper programming check

Insert the brown key, disabling the transponder (i.e., by tilting the key hood by 90°), and turn the key to the «ON» position. Perform the engine start-up operation. Ensure that the engine does not start. Insert the red key and start up again. Check that engine starts.

WARNING

IF THE ENGINE STARTS WITH THE BROWN KEY (AND WITH A DISABLED TRANSPONDER) OR IF DURING THE PROGRAMMING A WRONG STEP HAS

BEEN CARRIED OUT, IT IS NECESSARY TO REPEAT THE PROCESS FROM THE BEGINNING.

Fuel tank (01_13)

Tilt up the lock protection cover; Insert the key and turn it counter-clockwise, then pull out the cover.



01_13

Opening the saddle (01_14, 01_15)

Push the key switch when it is in the «ON» or «OFF» position.



01_14



01_15

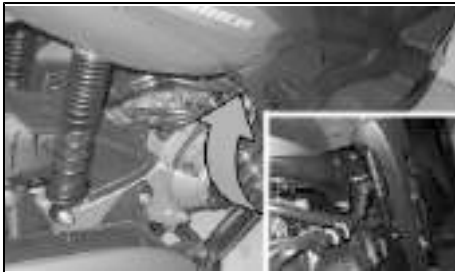

01_16



01_17

Identification (01_16, 01_17)

The identification numbers consist of a prefix stamped on the chassis and on the engine, followed by a number. They should always be given when requesting spare parts. We recommend that you check that the prefix and chassis number stamped on the vehicle correspond with those in the vehicle documents.

CAUTION



BE REMINDED THAT ALTERING IDENTIFICATION REGISTRATION NUMBERS CAN LEAD TO SERIOUS PENAL SANCTIONS (IMPOUNDING OF THE VEHICLE, ETC.).

Runner ST 125 - 200



Chap. 02
Use

Checks

Before using the vehicle, check:

1. There is enough fuel in the fuel tank.
2. The correct fluid level for front and rear brakes.
3. That tyres are properly inflated.
4. The correct functioning of tail lights, headlamp, turn indicators, stop light and license plate light.
5. The correct functioning of front and rear brakes.
6. The oil level in the gearcase.
7. The engine oil level.
8. The coolant level.



Refuelling (02_01, 02_02)

Fill the fuel tank with unleaded petrol "A" with an octane number higher than 95. When the fuel reaches the reserve level, the warning light "B" fitted on the instrument panel lights up.

CAUTION



SHUT OFF THE ENGINE BEFORE REFUELLING WITH PETROL. PETROL IS HIGHLY FLAMMABLE. DO NOT LET PETROL SPILL FROM THE TANK OR WHILE REFUELLING

CAUTION

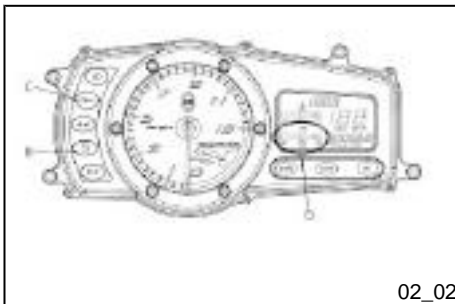

DO NOT BRING NAKED FLAMES OR CIGARETTES NEAR THE MOUTH OF THE FUEL TANK: FIRE HAZARD. ALSO AVOID INHALING HARMFUL VAPOURS.

**CAUTION**

THE USE OF OILS AND SPARK PLUGS OTHER THAN THOSE RECOMMENDED CAN SHORTEN THE LIFE OF THE ENGINE.

CAUTION

IF ONLY THE FIRST AND THE LAST SEGMENTS OF THE FUEL LEVEL INDICATOR FLASH, CONTACT AN AUTHORISED PIAGGIO SERVICE CENTRE TO CHECK THE INDICATOR.

WARNING

DO NOT RIDE WITH THE FUEL TANK ALMOST EMPTY, LACK OF FUEL CAN DAMAGE THE CATALYTIC CONVERTER.

Characteristic**Fuel tank**

Plastic, 8.5 l tank (estimated value) including the fuel reserve ~ 1.7 l

Tyre pressure**CAUTION**

TYRE PRESSURE SHOULD BE CHECKED WHEN TYRES ARE COLD. INCORRECT TYRE PRESSURE CAUSES ABNORMAL TYRE WEAR AND MAKES RIDING DANGEROUS.

TYRES MUST BE REPLACED WHEN THE TREAD REACHES THE WEAR LIMITS SET FORTH BY LAW.

Characteristic

Front wheel pressure:

1.7 bar

Rear tyre pressure:

2 bar

Rear tyre pressure (rider and luggage)

2.2 bar



Running in (02_03)

WARNING



DURING THE FIRST 1000 KM DO NOT RIDE THE VEHICLE OVER 80% OF ITS MAXIMUM SPEED. AVOID TWISTING THE THROTTLE GRIP FULLY OR KEEPING A CONSTANT SPEED ALONG LONG SECTIONS OF ROAD. AFTER THE FIRST 1000 KM, GRADUALLY INCREASE SPEED UNTIL REACHING THE MAXIMUM PERFORMANCE.

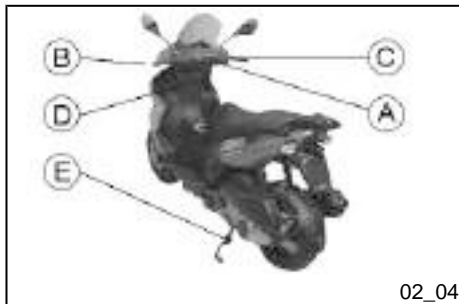

02_04

Starting up the engine (02_04)

The vehicle is equipped with an automatic transmission system with a speed variator and centrifugal clutch. For this reason, the throttle must be slightly untwisted while the engine is being started; to start-off from stationary position, progressively twist the throttle grip.

The vehicle is equipped with a fuel pump and a starter that switch on automatically as soon as the engine is started.

In order to start the engine, it is necessary to pull either the rear brake lever "B" or the front brake lever "C", before pressing the starting button, "A", so as to disengage the safety switches.

Proceed as follows:

- 1: Put the scooter on its stand "E"; check that the rear wheel is off the ground.
- 2: Keep the throttle closed.
- 3: Insert the key into the ignition switch, "D", and turn to the **ON** position.
- 4: Push the starter button «A» after pulling the rear brake lever «B» or the front brake lever «C».

CAUTION



DO NOT CARRY OUT THESE OPERATIONS IN CLOSED AREAS SINCE EXHAUST GASES ARE TOXIC.

WARNING



THE AUTOMATIC TRANSMISSION MAKES THE REAR WHEEL TURN EVEN WHEN THE THROTTLE IS SLIGHTLY TWISTED. RELEASE THE BRAKE CAREFULLY AFTER STARTING, AND THEN ACCELERATE GRADUALLY.

CAUTION



NEVER STRESS THE ENGINE AT LOW TEMPERATURES IN ORDER TO AVOID POSSIBLE DAMAGE. BE CAREFUL NEVER TO EXCEED THE MAXIMUM SPEED WHILE RUNNING DOWNHILL, IN ORDER TO AVOID DAMAGING THE ENGINE. IN ANY CASE, IN ORDER TO PRESERVE THE ENGINE FROM PROLONGED EXCESSIVE REVOLUTIONS, THE REVOLUTION LIMITER WILL BE ACTIVATED IF THE ENGINE SPEED EXCEEDS THE ESTABLISHED THRESHOLD.

Difficult start up

If there is a problem you can follow the instructions below:

1. If the engine is flooded. Follow the same sequence of operations described above. Fully accelerate and use the starter button alternating five seconds of rotation with five seconds of full throttle, because the operation of opening and closing the throttle valve causes further refilling of fuel into the cylinder. If after a few attempts it has not started, leave the motor rest for a few minutes and then repeat the preceding operations; in any case do not persist for too long with the starter motor in the attempt to start the engine. As the last operation, remove the spark plug while turning on the starter motor in order to expel any excess fuel; then refit the spark plug and repeat the process from point 1.

2. Overheated engine. Follow the same sequence of procedures, keeping the throttle slightly open. If the scooter does not start even with the above methods, turn to an **Authorised Piaggio-Gilera Dealer or Service Centre.**

3. If the battery is dead; starting with an auxiliary battery.

If the battery is dead it is possible to start the engine by means of a connection to another battery, with cables capable of accepting high current and with clamps at the ends. If the auxiliary battery is installed in another scooter, do not allow the two scooters to touch and position them both on the centre stand (if the other scooter has one).

Proceed as follows:

- a) Switch off all services and users, start up the vehicle with the auxiliary battery and make the engine run slightly above idle to ensure deep battery charge; then turn off the engine.
- b) Turn off everything and turn the scooters' key switch to "OFF."
- c) Connect the positive terminal (+) of the discharged battery to the positive terminal (+) of the auxiliary battery, and the negative terminal (-) of the discharged battery to the negative terminal (-) of the auxiliary battery.
- d) Try to start the scooter by alternating 5 seconds of turning the starter motor with 5 seconds of pause. If the motor does not start after 20" of using the start-up system, do not continue with the attempt, since the scooter might not start due to some other problem.
- e) Once the engine has started, keep it running slightly above idle and disconnect the cable (one cable at a time from both battery terminals) following the reverse mounting procedure: first the negative terminal (-) and then the positive one (+). As soon as you can, control the electrolyte level (in the case of unsealed batteries) and top up with distilled water, if necessary. If the fault that causes the battery to discharge is unknown, contact an **Authorised Piaggio Service Centre** to check the vehicle's electrical system.

Stopping the engine (02_05)

Stop acceleration, then turn the key switch "D" to "OFF " to turn off the engine (extractable key).

WARNING



AFTER A LONG DISTANCE COVERED AT THE MAXIMUM SPEED, DO NOT STOP THE ENGINE IMMEDIATELY, BUT LET IT RUN AT IDLE FOR A FEW SECONDS.

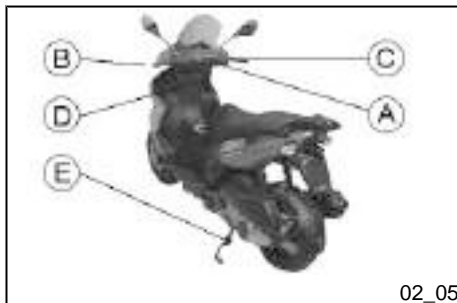

Catalytic silencer

CAUTION



TAMPERING WITH THE CATALYTIC MUFFLER MAY CAUSE SEVERE DAMAGE TO THE ENGINE

CAUTION



WHEN PARKING THE VEHICLE, DUE TO THE HIGH TEMPERATURES THE CATALYTIC CONVERTER CAN REACH, ALWAYS BE CAREFUL THAT THE MUFFLER DOES NOT COME INTO CONTACT WITH FLAMMABLE MATERIALS, TO AVOID SERIOUS BURNS.

CAUTION



DO NOT SWITCH OFF THE ENGINE WHILE THE VEHICLE IS MOVING. UNBURNED FUEL COULD ENTER THE CATALYTIC CONVERTER AND BURN, CAUSING IT TO OVERHEAT AND POSSIBLY DESTROYING IT.

Automatic transmission

To ensure simple, pleasurable riding, the vehicle is equipped with automatic transmission with regulator and centrifugal clutch. The system is designed to give the best possible performance in terms of both acceleration and consumption, on level ground and uphill, thanks to the adjustments made to engine speed and transmitted torque. If you have to stop on an uphill slope (traffic lights, traffic jam, etc.) only use the brake to keep the vehicle still, leaving the motor running at idling speed. Using the motor to keep the vehicle still can cause the clutch to overheat. This problem is due to the

friction of the clutch parts on the clutch bell. It is therefore recommended to avoid conditions of prolonged clutch slippage leading to clutch overheating (for example, as well as the situation described above, riding uphill fully laden on steep slopes or starting off on slopes greater than 25%, etc.):

1. Do not continue riding in such conditions.
2. Let the clutch cool down with the motor at idling speed for a few minutes.

Safe driving

WARNING



SOME SIMPLE TIPS ARE PROVIDED BELOW THAT WILL ENABLE YOU TO USE YOUR SCOOTER ON A DAILY BASIS IN GREATER SAFETY AND WITH MORE PEACE OF MIND.

<

Your ability and your knowledge of the vehicle form the basis of safe riding. We recommend trying out the vehicle in traffic-free zones to get to know your vehicle completely.

ALWAYS DRIVE WITHIN YOUR LIMITS

1. Before riding off, remember to put on your helmet and fasten it correctly.
2. Reduce speed and ride cautiously on uneven roads.
3. Remember that after riding on a long stretch of wet road without using the brakes, the braking effect is initially lower. Given these conditions, it is a good idea to operate the brakes from time to time.
4. Do not brake hard on a wet surface, on dirt tracks or on any slippery road surface.
5. If you have to brake, use both brakes in order to divide the braking action between both wheels.

6. Avoid starting off by mounting the scooter while it is still resting on its stand. In any case, the rear wheel should not be turning when it comes into contact with the ground, in order to avoid abrupt departures.

7. If the vehicle is used on roads covered with sand, mud, snow mixed with salt, etc., clean the brake disc frequently with mild detergent in order to prevent abrasive substances from building up within the holes, which can result in early wear of the brake pads.

8. Any elaboration that modifies the vehicle's performances, such as tampering with original structural parts is strictly forbidden by law, and renders the vehicle not conforming to the approved type and therefore dangerous to ride.

CAUTION



DO NOT FORGET THAT DRIVING IN A STATE OF DRUNKENNESS, OR WHEN UNDER THE EFFECT OF DRUGS OR CERTAIN MEDICINES, CAN BE EXTREMELY DANGEROUS FOR ONESELF AND FOR OTHERS.

CAUTION



ANY CHANGES TO THE VEHICLE PERFORMANCE AS WELL AS ALTERATIONS TO ORIGINAL STRUCTURAL PARTS IS STRICTLY FORBIDDEN BY LAW, AND RENDERS THE VEHICLE NO LONGER CONFORMING TO THE APPROVED TYPE AND DANGEROUS FOR RIDING.

Air conveyors (02_06)

The vehicle is equipped with 2 air vents designed to draw hot air coming from the radiator to the rider, to make riding in winter or in low-temperature conditions more comfortable.

To open or close the air vents use the control "A" located on one of the wings.



02_06

Runner ST 125 - 200



**Chap. 03
Maintenance**



03_01



03_02



03_03

Engine oil level

In 4T engines, the engine oil is used to lubricate the distribution elements, the bench bearings and the thermal group. **An insufficient quantity of oil can cause serious damage to the engine.** In all four-stroke engines, a loss of efficiency in oil performance and consumption should be considered normal. Consumption can particularly reflect the conditions of use (i.e. when driving at "full acceleration" all the time, oil consumption increases). **In order to prevent any problems, we recommend checking the oil level any time you use the vehicle. The scooter is, however, equipped with an oil pressure warning light on the instrument panel.**

Engine oil level check (03_01)

Every time the vehicle is used, visually inspect the level of the engine oil when the engine is cold (after **completely unscrewing** the oil cap/dipstick). The oil level should be somewhere between the MAX and MIN index marks on the level rod; «**A**»; during the oil check, the vehicle must be resting on its centre stand on an even, horizontal surface.

If the check is carried out after the vehicle has been used, and therefore with a hot engine, the level line will be lower; in order to carry out a correct check, wait at least 10 minutes after the engine has been stopped so as to get the correct level.

Characteristic

Engine oil (oil and oil filters change)

Capacity: 1.0 l

Warning light (insufficient oil pressure) (03_02)

The scooter is equipped with a warning light «**H**» that lights up when the key is turned to «**ON**».

However, this light should switch off once the engine has been started.

If the light comes on while braking, at idle speed or while turning a corner, it is necessary to check the oil level and top it up if required. If, after having topped up the oil, the warning light keeps on turning on while braking, at idling speed



or while turning a corner, it will be necessary to take your vehicle to an Authorised Piaggio Service Centre.

Engine oil change (03_03, 03_04)

The engine oil and cartridge filter, "C", must be replaced after the first km, and every 6.000 km thereafter, by an **Authorised Piaggio Service Centre**.

The engine should be emptied by draining the oil from the drainage plug «B » of the gauze filter on the flywheel side. In order to facilitate the oil drainage, loosen the cap/dipstick. Since a certain quantity of oil still remains in the circuit, filling must be done with approx. 600 ÷ 650 cm³ of oil through the cap «A ». Then start up the scooter, leave it running for a few minutes and switch it off: after about five minutes check the level and if necessary top up **without exceeding the MAX level**.

The cartridge filter must be replaced every time the oil is changed. For top-ups and changes, use new oil of the recommended type.

WARNING



RUNNING THE ENGINE WITH INSUFFICIENT LUBRICATION OR WITH INADEQUATE LUBRICANTS ACCELERATES THE WEAR AND TEAR OF THE MOVING PARTS AND CAN CAUSE IRRETRIEVABLE DAMAGE.

WARNING



EXCESSIVE OIL LEVEL AT TOP-UPS CAN LEAD TO SCALE FORMATION AND VEHICLE MALFUNCTIONING.

CAUTION



USED OILS CONTAIN SUBSTANCES HARMFUL TO THE ENVIRONMENT. FOR OIL REPLACEMENT, CONTACT AN AUTHORISED PIAGGIO SERVICE CENTRE,

AS THEY ARE EQUIPPED TO DISPOSE OF SPENT OILS IN AN ENVIRONMENTALLY FRIENDLY AND LEGAL WAY.

CAUTION



USING OILS OTHER THAN THOSE RECOMMENDED CAN SHORTEN THE LIFE OF THE ENGINE.

Recommended products

AGIP CITY HI TEC 4T

Engine oil

SAE 5W-40, API SL, ACEA A3, JASO MA Synthetic oil

Characteristic

Engine oil

Capacity: 1.1 lt. dry; 1.0 l oil filter change

Hub oil level (03_05, 03_06, 03_07)

To check the hub oil level, proceed as follows:

1. Place the vehicle on its stand on a level surface;
2. Unscrew the oil dipstick «A», dry it with a clean rag and then reinsert it, **screwing it tightly into place;**
3. Unscrew the dipstick again and check that the oil level is between the **first and second notches from the bottom;**
4. Screw the dipstick back into place completely.

The screw «B» is the hub oil drainage plug.



03_05

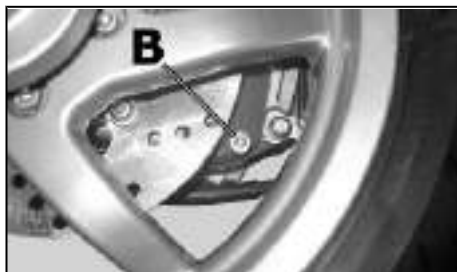

03_06

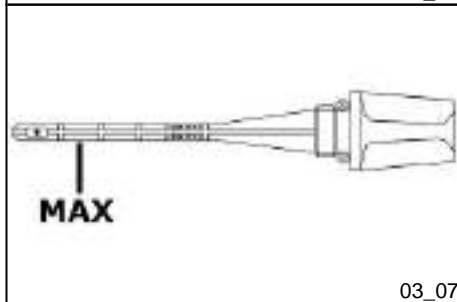

03_07

CAUTION

USING THE ENGINE WITH INSUFFICIENT LUBRICATION OR WITH THE WRONG LUBRICANTS MAY INCREASE WEAR AND TEAR ON THE MOVING PARTS AND MAY CAUSE SERIOUS DAMAGE.

CAUTION

USED OILS CONTAIN SUBSTANCES HARMFUL TO THE ENVIRONMENT. FOR OIL REPLACEMENT, CONTACT AN AUTHORISED SERVICE CENTRE, WHICH IS EQUIPPED TO DISPOSE OF USED OILS IN AN ENVIRONMENTALLY FRIENDLY AND LEGAL WAY.

N.B.

THE NOTCHES ON THE HUB OIL LEVEL DIPSTICK, EXCEPT THOSE INDICATING THE MAXIMUM AND MINIMUM LEVELS, REFER TO OTHER MODELS BY THE MANUFACTURER, AND HAVE NO SPECIFIC FUNCTION FOR THIS MODEL.

Recommended products**AGIP ROTRA 80W-90***Rear hub oil*

SAE 80W/90 Oil that exceeds the requirements of API GL3 specifications

Characteristic**Rear hub oil**

Capacity ~ 150 cm³

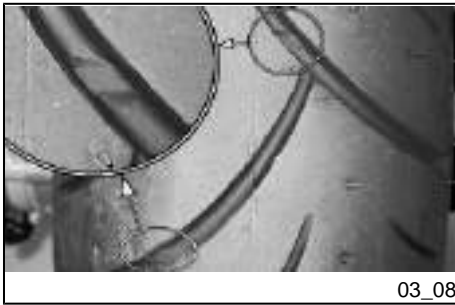

Tyres (03_08)

CAUTION



TYRE PRESSURE SHOULD BE CHECKED WHEN TYRES ARE COLD. INCORRECT TYRE PRESSURE CAUSES ABNORMAL TYRE WEAR AND MAKES RIDING DANGEROUS.

TYRES MUST BE REPLACED WHEN THE TREAD REACHES THE WEAR LIMITS SET FORTH BY LAW.

WARNING



THE WHEELS FITTED WITH TYRES SHOULD ALWAYS BE BALANCED. RIDING THE VEHICLE WITH VERY LOW TYRE PRESSURE OR WITH INCORRECTLY BALANCED TYRES CAN LEAD TO DANGEROUS STEERING VIBRATIONS.

Characteristic

Front wheel pressure:

1.7 bar

Rear tyre pressure:

2 bar

Rear tyre pressure (rider and luggage)

2.2 bar

Spark plug dismantlement (03_09, 03_10, 03_11)

Remove one of the two sides of the footrest, unscrewing the four fastening screws, one of which is under the passenger footrest.

Detach the spark plug shielded cap and remove the plug with the box-spanner supplied.

To reinstall it, screw in the spark plug by hand, setting it at the necessary angle; Use the wrench only to fasten it. Carefully reinsert the screening hood.

When refitting, use caution while inserting the passenger footrest in its hole in side-panel, then tighten the four screws manually.

CAUTION



FOLLOW THESE PROCEDURES VERY CAREFULLY TO AVOID ANY SEVERE DAMAGE THAT MAY BE CAUSED BY THE VERY POWERFUL IGNITION SYSTEM.

CAUTION



THE SPARK PLUG MUST BE REMOVED WHEN THE ENGINE IS COLD.

USING IGNITION ELECTRONIC CENTRAL UNITS OR SPARK PLUGS OTHER THAN THE TYPES PRESCRIBED (SEE «TECHNICAL DATA» SECTION) CAN CAUSE SERIOUS DAMAGE TO THE ENGINE.

Characteristic

Spark plug (125)

Champion RG 4 HC

NGK CR 8 EB

Spark plug (200)



03_09



03_10



03_11

CHAMPION RG 6 YC

NGK CR 8 EB

Spark plug: electrode distance

0.7 mm ÷ 0.8 mm

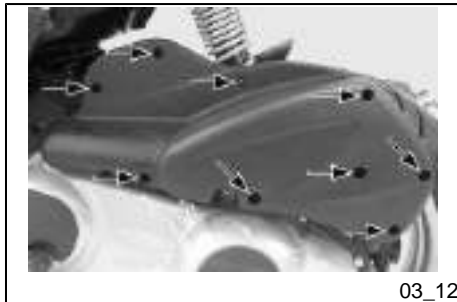

Removing the air filter (03_12)

Proceed as follows:

- Loosen the 9 clamping screws and remove the air filter cover;
- Remove the filter element and clean it with water and shampoo; then dry it with a clean cloth and slight blows of compressed air. Finally, immerse it in a mixture containing 50% of oil of the recommended type and 50 % of petrol.
- Gently squeeze the filter element, let it drip and then refit it.

CAUTION



IF THE VEHICLE IS USED ON DUSTY ROADS IT IS NECESSARY TO CARRY OUT MAINTENANCE CONTROLS OF THE AIR FILTER TO AVOID DAMAGING THE ENGINE.

CAUTION



IN ORDER NOT TO DAMAGE THE VEHICLE PLASTIC COVERS CONTACT AN AUTHORISED SERVICE CENTRE TO HAVE THE AIR FILTER CLEANED.

Recommended products

AGIP FILTER OIL

Oil for air filter sponge

Mineral oil with specific additives for increased adhesiveness

Secondary air system (03_13)

In order to reduce polluting emissions, the vehicle is furnished with a catalytic converter in the muffler.

To facilitate the catalytic process, a further quantity of previously filtered air is brought in through the exhaust duct on the head by the secondary air system (SAS).

This system allows more oxygen to be added to the unburned gases before reaching the catalytic converter, thus improving the catalytic converter reaction.

The system has a control valve that disables operation during deceleration in order to avoid abnormal noises.

To ensure the best functioning of the SAS, take your vehicle to an **Authorised Service Centre** for maintenance operations, at the intervals indicated in the scheduled maintenance table.

This system requires a filter «A».

The filter sponge should be cleaned with water and mild soap, then it should be dried with a cloth and slight blows of compressed air.

Cooling fluid level (03_14, 03_15)

The engine cooling takes place through a forced fluid circulation system. The cooling circuit contains around 1.8 l of cooling fluid consisting of a mixture of 50% de-ionised water and ethylene glycol and corrosion inhibitors based antifreeze solution.

The system has a coolant temperature indicator.

Under normal running conditions, the digital instrument indicator must light up to its 7th/ 8th segment.

When the 10th segment lights up, the icon and the bars start flashing; if this is the case, stop the engine and let it cool off; then check the fluid level. If the fluid level is correct, contact an **Authorised Piaggio Service Centre** to find the fault that caused the system to fail.

The fluid level must be carried out when the engine is cold, the first time after the first 1,000 km and thereafter every 6,000 km of use following this procedure:

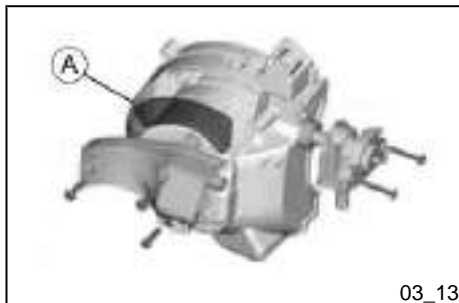

03_13



03_14

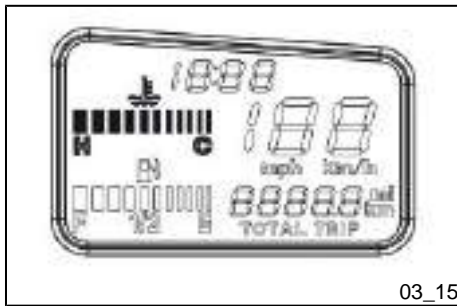

a) Put the vehicle in vertical position on its centre stand.

b) Remove the expansion tank cap "A" by turning it anticlockwise.

The fluid level can be visually checked once the front shield central cover has been removed. If the fluid is near the minimum level, proceed with the top-up operation to be carried out when the **engine is cold**.

If it is necessary to top up the cooling fluid frequently, or if the expansion tank is completely dry, you should look for a leak in the cooling system. It is therefore absolutely necessary to have the cooling system checked at an **Authorised Piaggio Service Centre**.

The cooling system fluid must be changed every 2 years. This operation must be carried out by trained technicians, please contact your nearest **Piaggio Dealer or Authorised Service Centre**.

N.B.

SHOULD THE 9th SEGMENT OF THE COOLANT TEMPERATURE INDICATOR COME ON DURING A NON-DEMANDING RIDE, SHUT OFF THE ENGINE AND LET IT COOL DOWN. THEN CHECK THE COOLANT LEVEL; IF THE LEVEL IS OK, CONTACT AN AUTHORISED SERVICE CENTRE.

WARNING



IN ORDER TO AVOID BURNS, DO NOT UNSCREW THE EXPANSION TANK CAP WHILE THE ENGINE IS STILL HOT.

CAUTION



IN ORDER TO AVOID HARMFUL FLUID LEAKS WHILE DRIVING, IT IS IMPORTANT TO MAKE SURE THAT THE LEVEL NEVER EXCEEDS THE MAXIMUM VALUE.

CAUTION

IF THE FIRST AND THE LAST SEGMENTS OF THE COOLANT LEVEL INDICATOR FLASH, CONTACT AN AUTHORISED PIAGGIO SERVICE CENTRE TO CHECK THE INDICATOR.

IF THE FIRST AND THE LAST SEGMENTS OF THE COOLANT LEVEL TEMPERATURE INDICATOR FLASH WHEN RIDING IN EXTREMELY LOW TEMPERATURE CONDITIONS -TEMPERATURE BELOW 15° C - JUST SWITCH OFF THE ENGINE AND WAIT FOR ONE MINUTE; THE FLASHING WILL AUTOMATICALLY STOP. IF THE SEGMENTS KEEP FLASHING, CONTACT AN AUTHORISED PIAGGIO SERVICE CENTRE.

Recommended products**SPECIAL AGIP PERMANENT fluid**

coolant

Monoethylene glycol-based antifreeze fluid, CUNA NC 956-16

Checking the brake oil level (03_16, 03_17)

The brake fluid reservoirs are fitted with a transparent indicator «**A**»; the amount of brake fluid seen through the transparent indicator shows the level of fluid contained in the reservoir.

When the indicator «**A**» is full, the level inside the reservoir exceeds the MIN level; when it is partially full, the level drops to the MIN level; when it is fully empty, the level of fluid in the reservoir is below the MIN level.

The brake fluid level may fall due to wear on the brake pads. In case the pad wear is below the minimum mark, contact an **Authorised Service Centre** to have the braking system thoroughly checked. If you need to top up the level, follow the steps listed below. Remove the front handlebar cover; loosen the 2 screws «**B**» and lift the brake fluid tank cover «**C**». Then, top up with fluid as necessary, (the fluid level must always exceed the minimum level mark). Place the handlebar in the riding position and pay

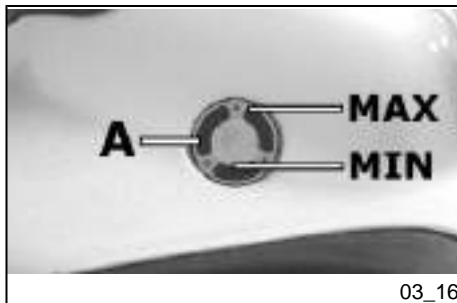

03_16

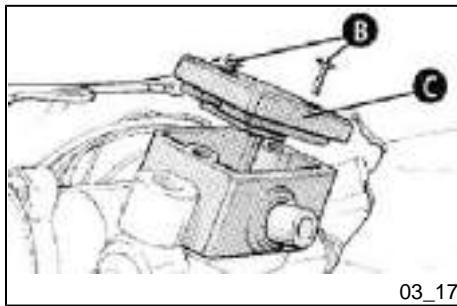

03_17

attention not to tilt the vehicle in order to keep the brake fluid reservoir in horizontal position when checking the fluid level.

CAUTION



TOP UPS SHOULD ONLY BE CARRIED OUT WITH DOT 4 CLASSIFIED BRAKE FLUID.

CAUTION



THE BRAKING CIRCUIT FLUID IS HIGHLY CORROSIVE. THEREFORE, WHEN TOPPING IT UP, AVOID LETTING IT COME INTO CONTACT WITH THE PAINTED PARTS OF THE VEHICLE. THE BRAKING CIRCUIT FLUID IS HYGROSCOPIC, WHICH MEANS THAT IT ABSORBS MOISTURE FROM THE SURROUNDING AIR. IF MOISTURE CONTAINED IN THE BRAKE FLUID EXCEEDS A CERTAIN VALUE, THIS WILL RESULT IN INEFFICIENT BRAKING.

WARNING



IN NORMAL CLIMATIC CONDITIONS IT IS ADVISABLE TO REPLACE THE ABOVE-MENTIONED FLUID EVERY 2 YEAR. NEVER USE BRAKE FLUID CONTAINED IN CONTAINERS WHICH ARE ALREADY OPEN OR PARTIALLY USED.

Recommended products

AGIP BRAKE 4

Brake fluid
FMVSS DOT 4 Synthetic fluid



03_18

Battery (03_18)

The saddle should be lifted in order to reach the battery. Loosen the four clamping screws "A" fitted on the cover.

To remove the battery disconnect the positive and negative cables from the vehicle's system.

The battery is the electrical device that requires the most frequent inspections and diligent maintenance.

CAUTION



ELECTROLYTE CONTAINS SULPHURIC ACID: AVOID CONTACT WITH EYES, SKIN AND CLOTHES. IN THE CASE OF ACCIDENTAL CONTACT, RINSE WITH ABUNDANT OF WATER AND CONSULT A DOCTOR.

WARNING



SPENT BATTERIES ARE HARMFUL FOR THE ENVIRONMENT. COLLECTION AND DISPOSAL SHOULD BE CARRIED OUT IN COMPLIANCE WITH CURRENT REGULATIONS.

Use of a new battery (03_19, 03_20)

If refitting or newly installing a battery, it is necessary to pass the positive and negative cables to the sides of the battery and then connect them to the terminals as shown in the diagram.



03_19



03_20

Long periods of inactivity

Battery performance will decrease if the vehicle is not used for a long time. This is the result of the natural phenomenon of battery discharging plus residual absorption by vehicle components with constant power consumption. Poor battery performance may also be due to environmental conditions and the cleanness of the poles. In order to avoid difficult starts and/or irreversible damage to the battery, follow any of these steps:

- **At least once a month** start the engine and run it slightly above idle speed for 10-15 minutes. This keeps all the engine components, as well as the battery, in good working order.

- Take your vehicle to a garage (as indicated in the "Vehicle not used for extended periods" section) to have the battery removed. Have the battery cleaned, charged fully and stored in a dry, ventilated place. Recharge **at least once every two months**.

N.B.

THE BATTERY MUST BE CHARGED WITH A CURRENT EQUAL TO 1/10 OF THE RATED CAPACITY OF THE BATTERY AND FOR NOT LONGER THAN 10 HOURS. CONTACT AN AUTHORISED SERVICE CENTRE TO CARRY OUT THIS OPERATION SAFELY. WHEN REFITTING THE BATTERY MAKE SURE THE LEADS ARE CORRECTLY CONNECTED TO THE TERMINALS.

WARNING



DO NOT DISCONNECT THE BATTERY CABLES WITH THE ENGINE RUNNING, THIS CAN CAUSE PERMANENT DAMAGE TO THE VEHICLE ELECTRONIC CONTROL UNIT.

WARNING

SPENT BATTERIES ARE HARMFUL FOR THE ENVIRONMENT. COLLECTION AND DISPOSAL SHOULD BE CARRIED OUT IN COMPLIANCE WITH CURRENT REGULATIONS.

Fuses (03_21, 03_22)

The electrical system is protected by 4 fuses fitted on the side of the battery.

If a fuse blows again after it has been replaced, contact an **Authorised Piaggio Service Centre** to look for the reason that may have caused the failure. Do not replace the fuse with any alternative form of conductor

CAUTION

BEFORE REPLACING THE BLOWN FUSE, SEARCH AND SOLVE THE PROBLEM THAT CAUSED IT TO BLOW.

NEVER TRY TO REPLACE A BLOWN FUSE WITH A FUSE OF A DIFFERENT RATING THAN THAT SPECIFIED OR USING OTHER MATERIAL (FOR EXAMPLE, A PIECE OF ELECTRICAL WIRE).



03_21

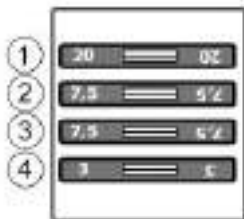

03_22

FUSE TABLE

Fuse No. 1	Position on fuse box: 1 Capacity: 20A Protected circuits: System protection main fuse Location: battery compartment
Fuse No. 2	Position on fuse box: 2 Capacity: 7.5 A Protected circuits: High- and low-beam light bulbs. Location: battery compartment
Fuse No. 3	Position on fuse box: 3 Capacity: 7.5 A Protected circuits: Stop light bulbs, engine start-up control, horn, instrument panel Location: battery compartment
Fuse No. 4	Position on fuse box: 4 Capacity: 3A Protected circuits: Front and rear tail light bulbs and license plate light Location: battery compartment

LIGHT BULBS TABLE

Low-beam bulb	Type: H8 Power: 12V - 35W Quantity: 1
High-beam light bulb	Type: H8 Power: 12V - 35W Quantity: 1
Front tail light bulb	Type: All glass Power: 12V - 3W Quantity: 2
Front turn indicator bulb	Type: Spherical Power: 12V - 10W Quantity: 1 RHS + 1 LHS
Rear turn indicator light bulb	Type: Spherical Power: 12V - 10W Quantity: 1 RHS + 1 LHS
Stop light bulb	Type: SPHERICAL Power: 12V - 10W Quantity: 2
Rear tail light bulb	Type: All glass

Power: 12V - 3W

Quantity: 2



03_23



03_24

Front light group (03_23, 03_24, 03_25)

In order to reach the headlamp bulb remove the snap-on Gilera shield by inserting the blade of a small screwdriver in the corresponding lateral notch, paying attention not to scratch the paint. Then loosen the screw underneath and lift up the front shield centre cover.

Then follow this procedure:

High and low beam bulb:

1. remove the rear cover and take the bulb holder; then turn it up around 30°;
2. disconnect the bulb connector and change the bulb.

Tail lights:

1. remove the rubber bulb socket from its housing; then remove the bulb and replace it.

Headlight adjustment (03_26, 03_27)

Proceed as follows:

1. Place the vehicle in running order and with the tyres inflated to the prescribed pressure, on a flat surface 10 m away from a white screen situated in a shaded area, making sure that the longitudinal axis of the scooter is perpendicular to the screen;
2. Turn on the headlight and check that the borderline of the projected light beam on the screen is not lower than 9/10 of the distance from the ground to the centre of vehicle headlamp and higher than 7/10;
3. Otherwise, regulate the headlamp by adjusting the screw "A", which can be reached after having removed the Piaggio shield cover.

N.B.

THE ABOVE PROCEDURE COMPLIES WITH THE EUROPEAN STANDARDS REGARDING MAXIMUM AND MINIMUM HEIGHT OF LIGHT BEAMS. REFER TO THE

STATUTORY REGULATIONS IN FORCE IN EVERY COUNTRY WHERE THE vehicle IS USED.



03_25



03_26

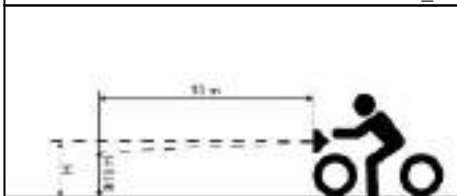

03_27

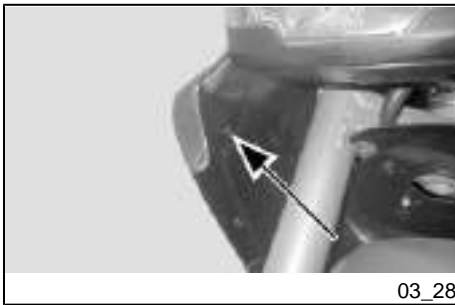

03_28

Front direction indicators (03_28)

To replace the front turn signal bulbs loosen the locking screws that fasten the bulb and then remove the rubber cap to be able to take off the bulb socket; gently turn the bulb around 30° and remove it. Follow the process in reverse order to refit.



03_29

Rear optical unit (03_29, 03_30, 03_31, 03_32)

To reach the taillight assembly bulbs remove the two screws "D", then pull out the entire bulb and proceed as follows:

Side tail lights:

The tail light bulbs and bulb sockets are snapped on their corresponding supports. It is therefore enough to pull bulb socket out of the headlamp in order to fit the new bulb.

Centre stop light bulbs:

In order to reach the stop light bulbs it is necessary to remove the rear light by unscrewing the two clamping screws that fasten the bulb support and glass together. Then, release the lateral ratchets, hold the burnt bulb and make a 30° turn to remove it and fit the new bulb.

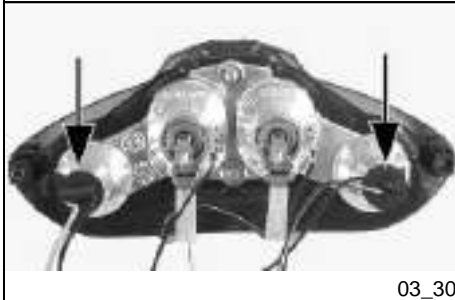

03_30

WARNING

IF MISTING IS NOTICED ON THE INSIDE OF THE HEADLAMP GLASS, THIS DOES NOT INDICATE A FAULT AND IS RELATED TO THE HUMIDITY AND/OR TO LOW TEMPERATURES.

THE PHENOMENON SHOULD QUICKLY DISAPPEAR WHEN THE LIGHT IS SWITCHED ON.



03_31



03_32

Rear turn indicators (03_33)

Loosen the screws fitted on the back of the turn indicator and remove the glass.

Hold the bulb gently and make a 30° anticlockwise turn; then remove it from the support and replace it.



03_33

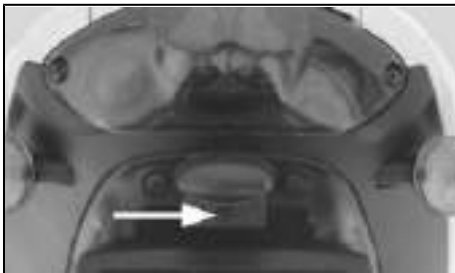

03_34

Number plate light (03_34)

Loosen the locking screws fitted on the license plate light support and remove it.

Remove the rubber bulb socket from its housing; then remove the bulb and replace it.



03_35

Rear-view mirrors (03_35)

The mirrors can be set to the desired position by adjusting the mirror frame.

The mirrors must be adjusted so that the shafts are perpendicular to the vehicle's direction axis.

To adjust the mirror opening angle loosen the screw fitted at the end of the shaft and fasten it once the desired position is reached.



03_36

Idle adjustment (03_36, 03_37)

To adjust idle it is necessary to reach the screw "A" located in the carburettor.

To carry out this adjustment it is necessary to reach the catalytic muffler as shown in the picture, or else by lifting the saddle and removing the hatch located at the bottom of the helmet compartment. Idle adjustment must be carried out with the rear wheel lifted off the ground (vehicle resting on centre stand) and with a hot engine. Tighten or loosen the screw until a regular idling speed is obtained before running the engine.

To adjust the throttle transmission clearance it is necessary to intervene on the adjustment screw "C" located on the right side of the carburettor. Once this operation is finished, refit the rubber cap protecting the adjustment screw.



03_37

CAUTION

WHEN ADJUSTING IDLE SPEED, PAY SPECIAL ATTENTION NOT TO TOUCH THE CATALYTIC MUFFLER TO AVOID BURNS.

CAUTION

IDLE SPEED MUST BE ADJUSTED WHEN THE ENGINE IS VERY HOT. BEFORE THIS OPERATION, MAKE SURE THAT THE THROTTLE GRIP HAS THE RECOMMENDED BACKLASH. IF BACKLASH IN THE THROTTLE GRIP TRANSMISSION NEEDS ADJUSTING TAKE YOUR VEHICLE TO AN AUTHORISED PIAGGIO-GILERA DEALER OR SERVICE CENTRE.

Characteristic**Idle speed**

~ 1650 ± 100 rpm

Front and rear disc brake (03_38, 03_39)

The brake disc and pad wear is automatically compensated, therefore it has no effect on the functioning of the front and rear brakes. For this reason it is not necessary to adjust the brakes. An excessively elastic brake lever stroke may indicate the presence of air in the braking circuit or an irregular brake operation. In this case, mainly due to the importance of brakes to guarantee safe riding conditions, the vehicle should be taken to an **Authorised Piaggio-Gilera Service Centre** in order to be checked.

CAUTION

BRAKE PADS MUST BE PERIODICALLY CHECKED (EVERY 6,000 KM) FOR SIGNS OF WEAR. IF THE THICKNESS OF ONE OR BOTH PADS IS IN THE RE-



03_38

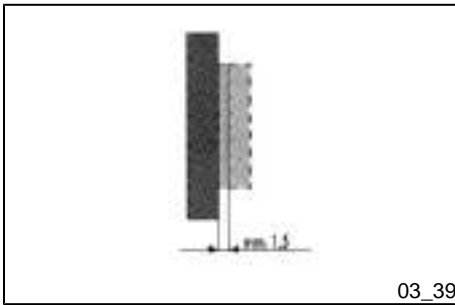

IF THE THICKNESS OF THE BRAKE PADS IS LESS THAN 1.5 MM, BOTH PADS MUST BE CHANGED. THIS OPERATION MUST BE CARRIED OUT AT AN AUTHORISED PIAGGIO-GILERA SERVICE CENTRE. AFTER REPLACING THE BRAKE PADS DO NOT USE THE VEHICLE BEFORE HAVING USED THE BRAKE LEVER SEVERAL TIMES IN ORDER TO ALLOW THE PADS TO SETTLE AND THE LEVER STROKE TO BE SET TO THE CORRECT POSITION.

CAUTION



THE BRAKING ACTION SHOULD BEGIN AFTER ABOUT 1/3 OF THE BRAKE LEVER STROKE.

CAUTION



THE PRESENCE OF SAND, MUD, SNOW MIXED WITH SALT, ETC. ON THE ROAD, CAN DRASTICALLY REDUCE THE DURATION OF THE BRAKE PADS. IN ORDER TO AVOID THIS, WE RECOMMEND WASHING THE VEHICLE FREQUENTLY WHEN RIDING IN THESE ROAD CONDITIONS.

Puncture (03_40)



The vehicle is equipped with Tubeless tyres. When there is a puncture, Tubeless tyres -unlike balloon tyres- go flat very slowly. This offers greater riding safety. A tyre that goes flat very slowly can be repaired with an "INFLATE AND REPAIR" spray. Tyres should be later fully repaired at an **Authorised Piaggio-Gilera Service Centre**.



Periods of inactivity (03_41)

We recommend carrying out the following operations:

1. General cleaning of the vehicle.
2. With the engine off and the piston at the bottom dead centre position, **remove the spark plug**, and pour 1÷ 2 cm³ of recommended oil through its opening. Press the engine start pedal 3 or 4 times letting the engine perform a few revolutions slowly, then replace the spark plug.
3. Drain off all the vehicle fuel; spread antirust grease on the unpainted metal parts; keep the wheels off the ground, by resting the chassis on two wooden wedges.
4. For the battery, follow the procedures described in the «Battery» section.
5. Drain the petrol from the carburettor float chamber through the bleed cap.

Recommended products

AGIP CITY HI TEC 4T

oil to lubricate flexible transmissions (throttle control)

Oil for 4-stroke engines

Cleaning the vehicle

Use a low pressure jet of water to soften the caked dirt and mud deposited on the painted surfaces. Once softened, mud and dirt should be removed with a soft sponge for bodywork soaked in water and "shampoo" (2-4% of shampoo in water). Then rinse abundantly with water, and dry with a shammy cloth. For the outside of the engine, use petroleum, a brush and clean cloths. Petrol can damage paintwork. Remember that any polishing with silicone wax must always be preceded by washing.

CAUTION



DETERGENTS POLLUTE WATER. THEREFORE THE VEHICLE SHOULD BE WASHED IN AN AREA EQUIPPED FOR THE COLLECTION AND PURIFICATION OF THE LIQUIDS USED.

WARNING

NEVER WASH THE VEHICLE UNDER DIRECT SUNLIGHT, ESPECIALLY IN SUMMER WHEN THE BODYWORK IS STILL HOT, AS THE CAR SHAMPOO MAY DRY BEFORE BEING RINSED OFF, AND COULD DAMAGE THE PAINTWORK. NEVER USE RAGS SOAKED IN PETROL OR DIESEL OIL TO CLEAN THE PAINTED OR PLASTIC SURFACES, TO PREVENT THEM LOSING THEIR SHINE AND MECHANICAL CHARACTERISTICS.

WARNING

WHEN WASHING THE ENGINE WITH A HIGH-PRESSURE WATER JET:

- **ONLY USE FAN SPRAY JETS.**
- **DO NOT PLACE THE WATER JET NOZZLE CLOSER THAN 60 CM.**
- **DO NOT USE WATER AT TEMPERATURES OVER 40° C.**
- **DO NOT DIRECT THE JETS DIRECTLY TO CARBURETTOR, WIRING, SLOT DIFFUSER ON THE TRANSMISSION COVER AND SCROLL COVER.**

CAUTION

AVOID USING ALCOHOL OR DETERGENTS WITH SIMILAR AGENTS TO CLEAN THE INSTRUMENT PANEL AND THE LIGHTING ASSEMBLIES.

WARNING

USE AN ANTISTATIC CLOTH TO CLEAN THE DISPLAY AREA ON THE CONTROL PANEL. IF AN ANTISTATIC CLOTH IS NOT USED, BLACK LINES MAY APPEAR ON THE DISPLAY, BUT THESE SHOULD DISAPPEAR QUICKLY AFTER THE ENGINE IS SWITCHED ON AND OFF A FEW TIMES IN NORMAL USE.

START-UP PROBLEMS

No fuel in tank	Refuelling
Filters, jets or carburettor dirty or clogged.	Contact an Authorised Service Centre.
Battery flat	Charge the battery (max. current equal to 1/10 of the battery capacity). In case of emergency try starting up with an auxiliary battery as described in the chapter "USE." As a final step, replace the battery with a new one.

IGNITION PROBLEMS

No spark from spark plug. Due to the presence of high voltage, this check should only be carried out by an expert.	Check that the electrodes are properly adjusted (0.7÷ 0.8 mm). Check that the electrodes are clean (clean with pure petrol and metal brush or with emery cloth). Check the spark plug insulator: Replace the spark plug if the insulator is cracked or broken. If the spark plug is in good conditions, contact an Authorised Service Centre.
--	---

LACK OF COMPRESSION

Spark plug loose. Loose cylinder head, worn piston retaining rings.	Contact an Authorised Service Centre.
---	--

HIGH CONSUMPTION AND LOW PERFORMANCE

Air filter blocked or dirty.	Clean with water and shampoo and impregnate with petrol and specific oil (section «Removing the air filter»)
------------------------------	--

INSUFFICIENT BRAKING

Greasy disc. Worn pads.	Contact an Authorised Piaggio-Gilera Service Centre .
Air in the brake assembly.	Contact an Authorised Piaggio-Gilera Service Centre .

INEFFICIENT SUSPENSION

Oil leak; worn limit switch bumpers; worn shock absorber attachment points	Contact an Authorised Service Centre
--	---

IRREGULAR AUTOMATIC TRANSMISSION

Deteriorated roller container or belt.	Contact an Authorised Service Centre .
--	---

INCREASED EXHAUST NOISE

Deterioration of the SAS system and/or of the tab	Contact an Authorised Service Centre .
---	---

STAND DOES NOT RETURN TO POSITION

Presence of dirt

Clean and grease

STARTER LEVER DOES NOT RETURN TO CORRECT POSITION

Presence of dirt

Clean and grease

Runner ST 125 - 200



Chap. 04
Technical data

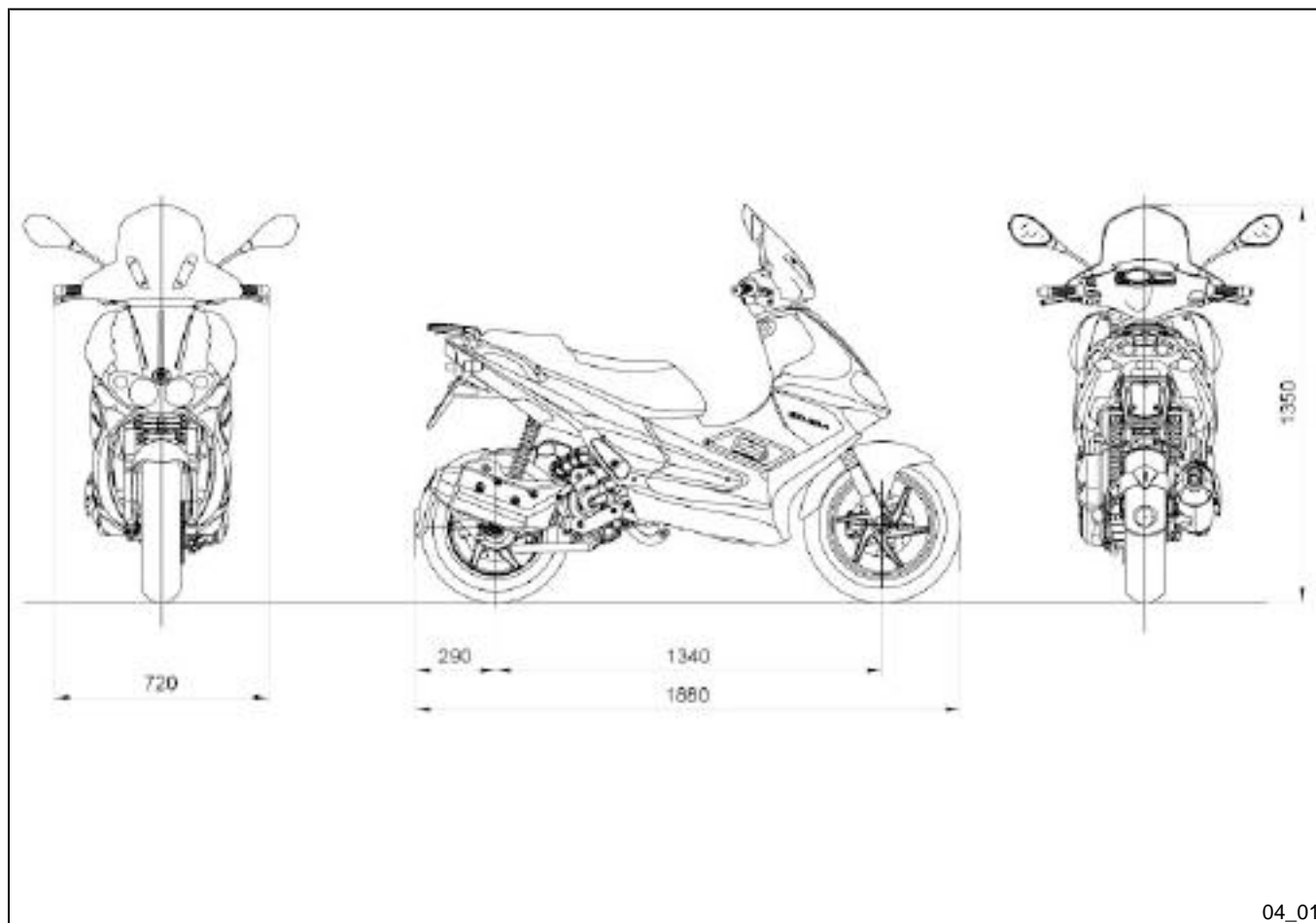

ENGINE TECHNICAL DATA

Engine	single-cylinder, four-stroke
Bore x stroke (125)	57 x 48.6 mm
Cubic capacity (125)	124 cm ³
Compression ratio (125)	11.5 - 12.5 1
Bore x stroke (200)	72 x 48.6 mm
Cubic capacity (200)	197 cm ³
Compression ratio (200)	11 ÷ 12 : 1
Timing system	single overhead camshaft driven by a chain on the left-hand side, 4 valves, three-arm rocking lever with set screw.
Cooling	forced-circulation fluid cooling by means of a centrifugal pump driven by the crankshaft
Lubrication	with lobe pump (inside the crankcase) controlled by a chain and double filter: mesh and paper
Electronic ignition	Consisting of a capacitor discharge ignition microprocessor with a built-in AT coil and variable advance
Variable ignition advance (before TDC) 125	Variable
Variable ignition advance (before TDC) 200	Variable (10° - 34°)

Spark plug (125)	Champion RG 4 HC NGK CR 8 EB
Spark plug (200)	CHAMPION RG 6 YC NGK CR 8 EB
Air Filter	Sponge, impregnated with mixture (50% SELÉNIA Air Filter Oil and 50% unleaded petrol).
Fuel supply	Unleaded petrol; carburettor and electrical pump.
Carburettor	KEIHIN CVK 30
Idle speed	~ 1650 ± 100 rpm
Engine oil	Capacity: 1.1 lt. dry; 1.0 l oil filter change
Rear hub oil	Capacity ~ 150 cm ³
Max. power (125)	11.0 kW at 9750 rpm
Max. torque (125)	12.0 Nm at 8000 rpm
Max. power (200)	14.0 kW at 8750 rpm
Max. torque (200)	17 Nm at 7250 rpm

TECHNICAL DATA

Maximum height	1350 mm
Max. length	1880 mm
Overall width	720 mm

Wheelbase	1340 mm
Fuel tank	Plastic, 8.5 l tank (estimated value) including the fuel reserve ~ 1.7 l
Front suspension	hydraulic double-acting telescopic fork with 35 mm stems
Front brake	Ø 240 mm disc brake (vehicle LHS), with hydraulic control activated by handlebar right lever.
Front tyre	Tubeless 120/70-14" 55P
Rear suspension	With coaxial spring and hydraulic shock absorber. Chassis to engine support with swinging arm.
Rear brake	Ø 220 mm disc brake with twin plunger callipers, hydraulically controlled by a handlebar lever on the left side.
Rear tyre	Tubeless 140/60-13" 63P
Wheels	Light alloy rims: FRONT 3.00 x 14" REAR 3.50 x 13"
Exhaust muffler	Absorption type, with a catalytic converter and a system of air intake to reduce polluting emissions.
Chassis	Modular double cradle frame made of welded tubular steel with sheet metal reinforcement.
Total kerb weight	129 Kg

Maximum load

Driver + passenger + baggage
(180 Kg)

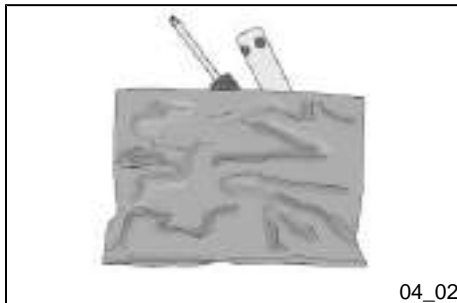

Kit equipment (04_02)

Wrenches: socket wrench (16 mm); a double ended screwdriver, a shock absorber wrench. The tools are stored under the seat in an appropriate container.

Runner ST 125 - 200



GILERA®



**Chap. 05
Spare parts and
accessories**



Warnings (05_01)

CAUTION



WE STRONGLY RECOMMEND USING ORIGINAL PIAGGIO-GILERA SPARE PARTS, THE ONLY PARTS THAT GUARANTEE THE SAME QUALITY LEVEL AS THE ORIGINAL PARTS ASSEMBLED ON THE VEHICLE.

IT SHOULD BE REMEMBERED THAT USING NON-ORIGINAL SPARE PARTS CAUSES YOUR WARRANTY RIGHTS TO EXPIRE.

CAUTION



PIAGGIO-GILERA MARKETS ITS OWN LINE OF ACCESSORIES, WHICH ARE COVERED BY A MANUFACTURER'S WARRANTY ON THE BASIS OF THEIR USE. IT IS THEREFORE ABSOLUTELY NECESSARY TO CONTACT AN AUTHORISED PIAGGIO-GILERA DEALER OR SERVICE CENTRE TO CHOOSE THEM AND HAVE THEM CORRECTLY ASSEMBLED. THE USE OF NON-ORIGINAL ACCESSORIES MAY AFFECT THE STABILITY AND OPERATION OF YOUR VEHICLE AND REDUCE SAFETY LEVELS WITH POTENTIAL RISKS FOR THE RIDER.

Runner ST 125 - 200



**Chap. 06
Programmed
maintenance**



06_01

Scheduled maintenance table (06_01)

Adequate maintenance is fundamental to ensuring long-lasting, optimum operation and performance of your vehicle.

To this end, a series of checks and maintenance operations (at the owner's expense) have been suggested, which are included in the summary table on the following page. Any minor faults should be reported without delay to an **Authorised Service Centre or Dealer** without waiting until the next scheduled service to solve it.

All scheduled maintenance services must be carried out at the specified times, even if the stated mileage has not yet been reached. Carrying out scheduled services on time is necessary to ensure your warranty remains valid. For any further information concerning Warranty procedures and "Scheduled Maintenance", please refer to the "Warranty Booklet".

MAINTENANCE TABLE

km x 1,000	1	6	12	18	24	30	36	42	48	54	60
Driven pulley roller casing			L		L		L		L		L
Safety locks	I		I		I		I		I		I
Spark plug		I	R	I	R	I	R	I	R	I	R
Driving belt		I	R	I	R	I	R	I	R	I	R
Throttle grip	A		A		A		A		A		A
Air filter		C	C	C	C	C	C	C	C	C	C
Oil filter		R	R	R	R	R	R	R	R	R	R
Valve clearance		A			A				A		
Electrical system and battery	I	I	I	I	I	I	I	I	I	I	I
Brake control lever	L		L		L		L		L		L
Brake fluid **	I	I	I	I	I	I	I	I	I	I	I

km x 1,000	1	6	12	18	24	30	36	42	48	54	60
Coolant **		I	I	I	I	I	I	I	I	I	I
Engine oil *	R	R	R	R	R	R	R	R	R	R	R
Hub oil	R	I	I	I	R	I	I	I	R	I	I
Headlight aiming adjustment			A		A		A		A		A
Brake pads	I	I	I	I	I	I	I	I	I	I	I
Sliding blocks / variable speed rollers		I	I	I	R	I	I	I	R	I	I
Tyre pressure and wear	I	I	I	I	I	I	I	I	I	I	I
Vehicle road test	I	I	I	I	I	I	I	I	I	I	I
Radiator (external cleaning)				I			I			I	
Idle speed	A		A		A		A		A		A
Odometer gear			L								L
Suspensions			I		I		I		I		I
Steering	A		A		A		A		A		A
Transmissions			L		L		L		L		L

I: CHECK AND CLEAN, ADJUST, LUBRICATE OR REPLACE, IF NECESSARY

C: CLEAN, R: REPLACE, A: ADJUST, L: LUBRICATE

Clean the SAS air filter every 2 years

** Check level every 3,000 km*

*** Replace every 2 years*

RECOMMENDED PRODUCTS TABLE

Product	Description	Specifications
AGIP ROTRA 80W-90	Rear hub oil	SAE 80W/90 Oil that exceeds the requirements of API GL3 specifications
AGIP CITY HI TEC 4T	Four-stroke engine oil	Lubricating oil for flexible shafts (throttle control)
AGIP FILTER OIL	Oil for air filter sponge	Mineral oil with specific additives for increased adhesiveness
AGIP CITY HI TEC 4T	Engine oil	SAE 5W-40 Synthetic oil that exceed the requirements of API SL, ACEA A3, JASO MA specifications
AGIP GP 330	Grease for brake control levers, throttle, stand	White calcium complex soap-based spray grease with NLGI 2; ISO-L-XBCIB2
AGIP GREASE SM 2	Grease for the tone wheel revolving ring	Soap-based lithium grease containing NLGI 2 Molybdenum disulphide; ISO-L-XBCHB2, DIN KF2K-20
AGIP BRAKE 4	Brake fluid	FMVSS DOT 4 Synthetic fluid
MONTBLANC MOLYBDENUM GREASE	Grease for driven pulley shaft adjusting ring and movable driven pulley housing	Grease with Molybdenum disulphide
AGIP GREASE PV2	Grease for the steering bearings, pin seats and swinging arm	White anhydrous-calcium based grease to protect roller bearings; temperature range between -20 C and +120 C; NLGI 2; ISO-L-XBCIB2.

TABLE OF CONTENTS

A

Air filter: 38

B

Battery: 43

Brake: 41, 53

D

Disc brake: 53

Display: 10

E

Engine oil: 32, 33

F

Fuel: 17

Fuses: 45

H

Headlight: 48

Horn: 13

Hub oil: 34

I

Identification: 18

Immobilizer: 14, 16

K

Key switch: 12

Keys: 14

L

Light switch: 13

M

Maintenance: 31, 69, 70

Mirrors: 52

S

Saddle: 17

Scheduled maintenance: 70

Spark plug: 37

Start-up: 14

T

Tank: 17

Technical Data: 61

Transmission: 26

Turn indicators: 51

Tyre pressure: 21

Tyres: 36



The descriptions and illustrations given in this publication are not binding. While the basic specifications as described and illustrated in this manual remain unchanged, PIAGGIO-GILERA reserves the right, at any time and without being required to update this publication beforehand, to make any changes to components, parts or accessories, which it considers necessary to improve the product or which are required for manufacturing or construction reasons.

Not all versions shown in this publication are available in all countries. The availability of single versions should be checked at the official Piaggio sales network.

"© Copyright 2005 - PIAGGIO & C. S.p.A. Pontedera. All rights reserved. Reproduction of this publication in whole or in part is prohibited."

PIAGGIO & C. S.p.A. - Q.C.S./After sales V.le Rinaldo Piaggio, 23 - 56025 PONTEDERA (Pi) www.piaggio.com