

OWNER'S MANUAL 2014

125 TC EU
250 TC EU

Art. no. 3402001en



THE PIONEERS OF MOTOCROSS

Husqvarna[®]
MOTORCYCLES

DEAR HUSQVARNA CUSTOMER

Congratulations on your decision to purchase a Husqvarna motorcycle. You are now the owner of a state-of-the-art sports motorcycle that will give you enormous pleasure if you service and maintain it accordingly.

We wish you a lot of enjoyment in riding this vehicle.

Enter the serial numbers of your vehicle below.

Chassis number (☛ p. 10)	Dealer's stamp
Engine number (☛ p. 10)	

The Owner's Manual contained the latest information for this model series at the time of going to print. Slight deviations resulting from continuing development and design can, however, not be completely excluded.

All specifications are non-binding. Husqvarna Motorcycles GmbH specifically reserves the right to modify or delete technical specifications, prices, colors, forms, materials, services, designs, equipment, etc., without prior notice and without specifying reasons, to adapt these to local conditions, as well as to stop production of a particular model without prior notice. Husqvarna accepts no liability for delivery options, deviations from illustrations and descriptions, as well as misprints and other errors. The models portrayed partly contain special equipment that does not belong to the regular scope of supply.

© 2013 Husqvarna Motorcycles GmbH, Mattighofen Austria

All rights reserved

Reproduction, even in part, as well as copying of all kinds, is permitted only with the express written permission of the copyright owner.



ISO 9001(12 100 6061)

Husqvarna applies quality assurance processes that lead to the highest possible product quality as defined in the ISO 9001 international quality management standard.





























Issued by: TÜV Management Service

Husqvarna Motorcycles GmbH
5230 Mattighofen, Austria

TABLE OF CONTENTS





1	MEANS OF REPRESENTATION	4	8.3	Starting off	21
1.1	Symbols used	4	8.4	Shifting, riding	21
1.2	Formats used	4	8.5	Braking	21
2	SAFETY ADVICE	5	8.6	Stopping, parking.....	22
2.1	Use definition - intended use	5	8.7	Transport	22
2.2	Safety advice	5	8.8	Refueling.....	23
2.3	Degrees of risk and symbols	5	9	SERVICE SCHEDULE.....	24
2.4	Tampering warning	5	9.1	Service schedule.....	24
2.5	Safe operation.....	5	9.2	Service work (as additional order).....	25
2.6	Protective clothing	6	10	TUNING THE CHASSIS	26
2.7	Work rules.....	6	10.1	Checking the basic chassis setting with the rider's weight	26
2.8	Environment.....	6	10.2	Compression damping of shock absorber.....	26
2.9	Owner's Manual.....	6	10.3	Adjusting the low-speed compression damping of the shock absorber	26
3	IMPORTANT INFORMATION	7	10.4	Adjusting the high-speed compression damping of the shock absorber	27
3.1	Manufacturer and implied warranty	7	10.5	Adjusting the rebound damping of the shock absorber	27
3.2	Operating and auxiliary substances	7	10.6	Measuring the sag of the unloaded rear wheel	28
3.3	Spare parts, accessories.....	7	10.7	Checking the static sag of the shock absorber....	28
3.4	Service.....	7	10.8	Checking the riding sag of the shock absorber....	29
3.5	Figures.....	7	10.9	Adjusting the spring preload of the shock absorber 🛠️.....	29
3.6	Customer service	7	10.10	Adjusting the riding sag 🛠️.....	30
4	VIEW OF VEHICLE	8	10.11	Checking the basic setting of the fork	30
4.1	View of the vehicle from the left front (example)	8	10.12	Adjusting the compression damping of the fork....	31
4.2	View of vehicle, rear right (example).....	9	10.13	Adjusting the rebound damping of the fork.....	31
5	SERIAL NUMBERS.....	10	10.14	Handlebar position	32
5.1	Chassis number	10	10.15	Adjusting the handlebar position 🛠️.....	32
5.2	Type label	10	11	SERVICE WORK ON THE CHASSIS.....	33
5.3	Engine number.....	10	11.1	Raising the motorcycle with the lift stand.....	33
5.4	Fork part number	10	11.2	Removing the motorcycle from the lift stand.....	33
5.5	Shock absorber part number	10	11.3	Bleeding the fork legs.....	33
6	CONTROLS.....	11	11.4	Cleaning the dust boots of the fork legs	33
6.1	Clutch lever.....	11	11.5	Loosening the fork protection.....	34
6.2	Hand brake lever.....	11	11.6	Positioning the fork protection.....	34
6.3	Throttle grip	11	11.7	Removing the fork legs 🛠️	34
6.4	Kill switch.....	11	11.8	Installing the fork legs 🛠️.....	35
6.5	Map-Select switch (250 TC EU).....	12	11.9	Removing the fork protector 🛠️	35
6.6	Opening the filler cap	12	11.10	Installing the fork protector 🛠️.....	36
6.7	Closing the filler cap	12	11.11	Removing the lower triple clamp 🛠️	36
6.8	Fuel tap.....	13	11.12	Installing the lower triple clamp 🛠️	37
6.9	Choke.....	13	11.13	Checking the play of the steering head bearing	38
6.10	Shift lever	13	11.14	Adjusting the play of the steering head bearing 🛠️	39
6.11	Kick starter.....	14	11.15	Greasing the steering head bearing 🛠️.....	39
6.12	Foot brake lever	14	11.16	Removing the start number plate	39
6.13	Plug-in stand.....	14	11.17	Installing the start number plate.....	40
7	PREPARING FOR USE	15	11.18	Removing the front fender.....	40
7.1	Advice on first use.....	15	11.19	Installing the front fender	40
7.2	Running in the engine.....	16	11.20	Removing the shock absorber 🛠️	41
7.3	Preparing the vehicle for difficult riding conditions	16	11.21	Installing the shock absorber 🛠️	41
7.4	Preparations for riding on dry sand.....	16	11.22	Removing the seat	42
7.5	Preparations for riding on wet sand.....	17	11.23	Mounting the seat	42
7.6	Preparations for riding on wet and muddy surfaces	18	11.24	Removing the air filter box lid	42
7.7	Preparations for riding at high temperatures and low speeds	18	11.25	Installing the air filter box lid.....	42
7.8	Preparing for riding at low temperatures or in snow.....	19	11.26	Removing the air filter 🛠️	42
8	RIDING INSTRUCTIONS.....	20	11.27	Cleaning the air filter and air filter box 🛠️.....	43
8.1	Checks and maintenance work when preparing for use	20	11.28	Installing the air filter 🛠️.....	43
8.2	Starting	20			

TABLE OF CONTENTS

11.29	Sealing the air filter box 	44	15.2	Adjusting the play in the throttle cable 	75
11.30	Removing the main silencer	44	15.3	Carburetor - idle	76
11.31	Installing the main silencer	44	15.4	Carburetor - adjusting the idle speed 	76
11.32	Changing the glass fiber yarn filling of the main silencer 	44	15.5	Emptying the carburetor float chamber 	77
11.33	Removing the right side cover	45	15.6	Plug-in connection, ignition timing map (125 TC EU)	78
11.34	Installing the right side cover	45	15.7	Changing the ignition curve	78
11.35	Removing the fuel tank 	45	15.8	Checking the basic position of the shift lever	78
11.36	Installing the fuel tank 	46	15.9	Adjusting the basic position of the shift lever 	79
11.37	Checking the chain for dirt	47	15.10	Engine characteristic - auxiliary spring (250 TC EU)	79
11.38	Cleaning the chain	47	15.11	Engine characteristic - set the auxiliary spring  (250 TC EU)	79
11.39	Checking the chain tension	48	16	SERVICE WORK ON THE ENGINE	81
11.40	Adjusting the chain tension	48	16.1	Checking the gear oil level	81
11.41	Checking the chain, rear sprocket, engine sprocket and chain guide	49	16.2	Changing the gear oil 	81
11.42	Checking the frame 	51	16.3	Draining the gear oil 	82
11.43	Checking the swingarm 	51	16.4	Refilling with gear oil 	82
11.44	Checking the routing of the throttle cable	51	16.5	Adding gear oil 	83
11.45	Checking the rubber grip	52	17	CLEANING, CARE	85
11.46	Additionally securing the rubber grip	52	17.1	Cleaning the motorcycle	85
11.47	Adjusting the basic position of the clutch lever	52	18	STORAGE	86
11.48	Checking/correcting the fluid level of the hydraulic clutch	53	18.1	Storage	86
11.49	Changing the hydraulic clutch fluid 	54	18.2	Preparing for use after storage	86
12	BRAKE SYSTEM	56	19	TROUBLESHOOTING	87
12.1	Checking the free travel of the hand brake lever	56	20	TECHNICAL DATA	89
12.2	Adjusting the basic position of the hand brake lever	56	20.1	Engine	89
12.3	Checking the brake discs	56	20.1.1	125 TC EU	89
12.4	Checking the front brake fluid level	57	20.1.2	250 TC EU	89
12.5	Adding front brake fluid 	57	20.2	Engine tightening torques	90
12.6	Checking the front brake linings	58	20.2.1	125 TC EU	90
12.7	Changing the front brake linings 	58	20.2.2	250 TC EU	91
12.8	Checking the free travel of foot brake lever	60	20.3	Capacities	92
12.9	Adjusting the basic position of the foot brake lever 	60	20.3.1	Gear oil	92
12.10	Checking the rear brake fluid level	61	20.3.2	Coolant	92
12.11	Adding brake fluid for the rear brake 	61	20.3.3	Fuel	92
12.12	Checking the rear brake linings	62	20.4	Chassis	92
12.13	Changing the rear brake linings 	62	20.5	Tires	93
13	WHEELS, TIRES	65	20.6	Fork	93
13.1	Removing the front wheel 	65	20.6.1	125 TC EU	93
13.2	Installing the front wheel 	65	20.6.2	250 TC EU	93
13.3	Removing the rear wheel 	66	20.7	Shock absorber	94
13.4	Installing the rear wheel 	67	20.7.1	125 TC EU	94
13.5	Checking the tire condition	67	20.7.2	250 TC EU	94
13.6	Checking the tire air pressure	68	20.8	Chassis tightening torques	95
13.7	Checking the spoke tension	68	20.9	Carburetor	96
14	COOLING SYSTEM	70	20.9.1	125 TC EU	96
14.1	Cooling system	70	20.9.2	Carburetor - basic setting for sandy surfaces (125 TC EU)	96
14.2	Radiator cover	70	20.9.3	250 TC EU	96
14.3	Installing the radiator cover	70	20.9.4	Carburetor - basic setting for sandy surfaces (250 TC EU)	96
14.4	Removing the radiator cover	71	20.10	Carburetor tuning	97
14.5	Checking the antifreeze and coolant level	71	20.10.1	Carburetor tuning (125 TC EU)	97
14.6	Checking the coolant level	72	20.10.2	Carburetor tuning (250 TC EU)	98
14.7	Draining the coolant 	72	20.10.3	General carburetor tuning 	99
14.8	Refilling with coolant 	73	21	SUBSTANCES	100
15	TUNING THE ENGINE	75	22	AUXILIARY SUBSTANCES	102
15.1	Checking the play in the throttle cable	75	23	STANDARDS	103
				INDEX	104

1.1 Symbols used

The symbols used are explained below.

	Indicates an expected reaction (e.g., to a work step or a function).
	Indicates an unexpected reaction (e.g., to a work step or a function).
	All work marked with this symbol requires specialist knowledge and technical understanding. In the interest of your own safety, have these jobs performed by an authorized Husqvarna workshop. There, your motorcycle will be optimally cared for by specially trained experts using the special tools required.
	Identifies a page reference (more information is provided on the specified page).

1.2 Formats used

The typographical and other formats used are explained below.

Specific name	Identifies a specific name.
Name[®]	Identifies a protected name.
Brand[™]	Identifies a brand available on the open market.

2.1 Use definition - intended use

Husqvarna sport motorcycles are designed and built to withstand the normal stresses and strains of competitive use. The motorcycles comply with currently valid regulations and categories of the top international motorsport organizations.



Info

The motorcycle may only be used in closed off areas remote from public road traffic.

2.2 Safety advice

A number of safety instructions need to be followed to operate the vehicle safely. Therefore, read this manual carefully. The safety instructions are highlighted in the text and are referred to at the relevant passages.



Info

The vehicle has various information and warning labels at prominent locations. Do not remove information/warning labels. If they are missing, you or others may not recognize dangers and may therefore be injured.

2.3 Degrees of risk and symbols



Danger

Identifies a danger that will immediately and invariably lead to fatal or serious permanent injury if the appropriate measures are not taken.



Warning

Identifies a danger that is likely to lead to fatal or serious injury if the appropriate measures are not taken.



Caution

Identifies a danger that may lead to minor injuries if the appropriate measures are not taken.

Note

Identifies a danger that will lead to considerable machine and material damage if the appropriate measures are not taken.



Warning

Identifies a danger that will lead to environmental damage if the appropriate measures are not taken.

2.4 Tampering warning

Tampering with the noise control system is prohibited. Federal law prohibits the following acts or the causing thereof:

- 1 The removal or rendering inoperative by any person other than for purposes of maintenance, repair, or replacement, of any device or element of design incorporated into any new vehicle for the purpose of noise control prior to its sale or delivery to the ultimate purchaser or while it is in use, or
- 2 the use of the vehicle after such device or element of design has been removed or rendered inoperative by any person.

Among those acts presumed to constitute tampering are the acts listed below:

- 1 Removal or puncturing of the main silencer, baffles, header pipes or any other components which conduct exhaust gases.
- 2 Removal or puncturing of parts of the intake system.
- 3 Lack of proper maintenance.
- 4 Replacing moving part of the vehicle, or parts of the exhaust or intake system, with parts other than those specified by the manufacturer.

2.5 Safe operation



Danger

Danger of accidents Danger arising from the rider's judgement being impaired.

- Do not operate the vehicle while under the influence of alcohol, drugs and certain medications or physically or mentally impaired.



Danger

Danger of poisoning Exhaust gases are toxic and inhaling them may result in unconsciousness and/or death.

- When running the engine, always make sure there is sufficient ventilation, and do not start or run the engine in an enclosed space without an effective exhaust extraction system.



Warning

Danger of burns Some vehicle components become very hot when the vehicle is operated.

- Do not touch hot components such as exhaust system, radiator, engine, shock absorber, and the brake system. Allow these components to cool down before starting work on them.

Only operate the vehicle when it is in perfect technical condition, in accordance with its intended use, and in a safe and environmentally compatible manner.

The vehicle should only be used by trained persons.

Have malfunctions that impair safety promptly eliminated by an authorized Husqvarna workshop.

Adhere to the information and warning labels on the vehicle.

2.6 Protective clothing



Warning

Risk of injury Missing or poor protective clothing presents an increased safety risk.

- Wear protective clothing (helmet, boots, gloves, pants and jacket with protectors) every time you ride the vehicle. Always wear protective clothing that is in good condition and meets the legal requirements.

In the interest of your own safety, Husqvarna recommends that you only operate the vehicle while wearing protective clothing.

2.7 Work rules

Special tools are necessary for certain tasks. The tools are not contained in the vehicle but can be ordered under the number in parentheses. E.g.: bearing puller (15112017000)

During assembly, non-reusable parts (e.g. self-locking screws and nuts, seals and seal rings, O-rings, pins, lock washers) must be replaced by new parts.

In some instances, a thread locker (e.g. **Loctite**[®]) is required. The manufacturer instructions for use must be followed.

After disassembly, clean the parts that are to be reused and check them for damage and wear. Change damaged or worn parts.

After you complete the repair or service work, check the operating safety of the vehicle.

2.8 Environment

If you use your motorcycle responsibly, you can ensure that problems and conflicts do not occur. To protect the future of the motorcycle sport, make sure that you use your motorcycle legally, display environmental consciousness, and respect the rights of others.

When disposing of used oil, other operating and auxiliary fluids, and used components, comply with the laws and regulations of the respective country.

Because motorcycles are not subject to the EU regulations governing the disposal of used vehicles, there are no legal regulations that pertain to the disposal of an end-of-life motorcycle. Your authorized Husqvarna dealer will be glad to advise you.

2.9 Owner's Manual

It is important that you read this Owner's Manual carefully and completely before making your first trip. The Owner's Manual contains useful information and many tips on how to operate, handle, and maintain your motorcycle. Only then will you find out how to customize the vehicle ideally for your own use and how you can protect yourself from injury.

Keep the Owner's Manual in an accessible place to enable you to refer to it as needed.

If you would like to know more about the vehicle or have questions on the material you read, please contact an authorized Husqvarna dealer.

The Owner's Manual is an important component of the vehicle and should be handed over to the new owner if the vehicle is sold.

3.1 Manufacturer and implied warranty

The work prescribed in the service schedule must be carried out by an authorized Husqvarna workshop only and confirmed in the customer's service & warranty booklet and in the **Husqvarna dealer.net**; otherwise, all warranty claims will be void. No warranty claims can be considered for damage resulting from manipulations and/or alterations to the vehicle.

Additional information on the manufacturer or implied warranty and the procedures involved can be found in the service & warranty booklet.

3.2 Operating and auxiliary substances



Warning

Environmental hazard Improper handling of fuel is a danger to the environment.

- Do not allow fuel to get into the ground water, the ground, or the sewage system.

Use operating and auxiliary substances (such as fuel and lubricants) as specified in the Owner's Manual.

3.3 Spare parts, accessories

For your own safety, only use spare parts and accessory products that are approved and/or recommended by Husqvarna and have them installed by an authorized Husqvarna workshop. Husqvarna accepts no liability for other products and any resulting damage or loss.

Certain spare parts and accessory products are specified in parentheses in the descriptions. Your authorized Husqvarna dealer will be glad to advise you.

The current **Husqvarna Husky Power** parts for your vehicle can be found on the Husqvarna website.

International Husqvarna website: www.husqvarna-motorcycles.com

3.4 Service

A prerequisite for perfect operation and prevention of premature wear is that the service, care, and tuning work on the engine and chassis is properly carried out as described in the Owner's Manual. Incorrect adjustment and tuning of the engine and chassis can lead to damage and breakage of components.

Use of the vehicle under difficult conditions, such as on sand or on wet and muddy surfaces, can lead to considerably more rapid wear of components such as the drive train, brake system, or suspension components. For this reason, it may be necessary to inspect or replace parts before the next scheduled service.

It is imperative that you adhere to the stipulated run-in times and service intervals. If you observe these exactly, you will ensure a much longer service life for your motorcycle.

3.5 Figures

The figures contained in the manual may depict special equipment.

In the interest of clarity, some components may be shown disassembled or may not be shown at all. It is not always necessary to disassemble the component to perform the activity in question. Please follow the instructions in the text.

3.6 Customer service

Your authorized Husqvarna dealer will be happy to answer any questions you may have on your vehicle and Husqvarna.

A list of authorized Husqvarna dealers can be found on the Husqvarna website.

International Husqvarna website: www.husqvarna-motorcycles.com

4.1 View of the vehicle from the left front (example)



1	Filler cap
2	Air filter box lid
3	Fuel tap (☛ p. 13)
4	Choke (☛ p. 13)
5	Shift lever (☛ p. 13)
6	Plug-in stand (☛ p. 14)

4.2 View of vehicle, rear right (example)



1	Clutch lever (☛ p. 11)
2	Kill switch (☛ p. 11)
3	Fork compression adjustment
4	Throttle grip (☛ p. 11)
5	Hand brake lever (☛ p. 11)
6	Shock absorber rebound adjustment
7	Level viewer for brake fluid, rear
8	Shock absorber compression adjustment
9	Foot brake lever (☛ p. 14)
10	Kick starter (☛ p. 14)
11	Fork rebound adjustment

5.1 Chassis number

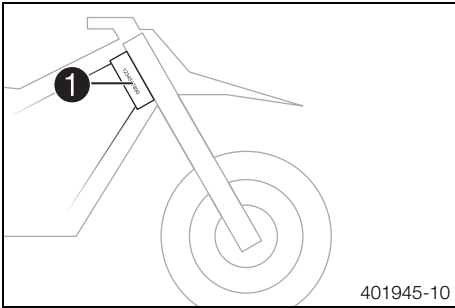

The chassis number ① is stamped on the right side of the steering head.

5.2 Type label

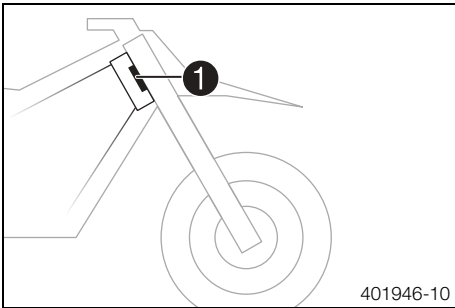

The type label ① is fixed to the front of the steering head.

5.3 Engine number

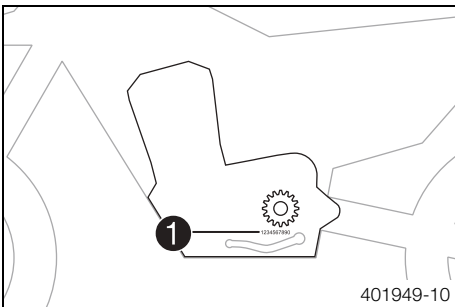

The engine number ① is stamped on the left side of the engine under the engine sprocket.

5.4 Fork part number

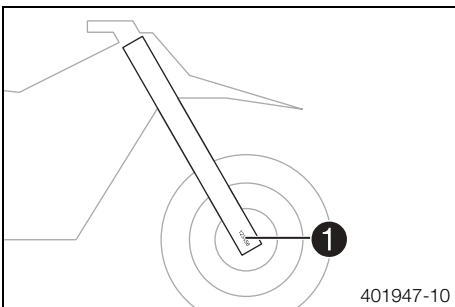

The fork part number ① is stamped on the inner side of the fork stub.

5.5 Shock absorber part number

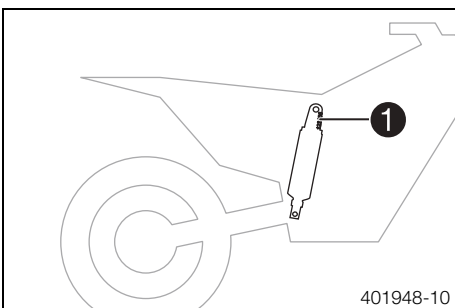

The shock absorber part number ① is stamped on the top of the shock absorber above the adjusting ring on the engine side.

6.1 Clutch lever



(125 TC EU)

The clutch lever **1** is fitted on the left side of the handlebar. The clutch is hydraulically operated and self-adjusting.



(250 TC EU)

The clutch lever **1** is fitted on the left side of the handlebar. The clutch is hydraulically operated and self-adjusting.

6.2 Hand brake lever



Hand brake lever **1** is located on the right side of the handlebar. The hand brake lever is used to activate the front brake.

6.3 Throttle grip





Throttle grip **1** is fitted on the right side of the handlebar.

6.4 Kill switch



The kill switch **1** is fitted on the left side of the handlebar.

Possible states

- Kill switch  in basic position – In this position, the ignition circuit is closed, and the engine can be started.
- Kill switch  pressed – In this position, the ignition circuit is interrupted, a running engine stops, and a non-running engine will not start.

6.5 Map-Select switch (250 TC EU)

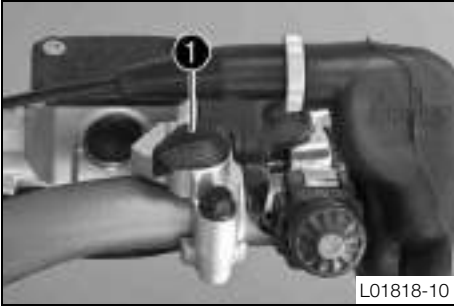

L01818-10

The **Map-Select** switch ❶ is fitted on the right side of the handlebar.

Possible states

I	Performance – This position is used for higher performance.
II	Soft – This position is used for better rideability.

The engine characteristic can be changed on the handlebar using the **Map-Select** switch.

6.6 Opening the filler cap



Danger

Fire hazard Fuel is highly flammable.

- Never refuel the vehicle near open flames or burning cigarettes, and always switch off the engine first. Be careful that no fuel is spilt, especially on hot vehicle components. Clean up spilt fuel immediately.
- The fuel in the fuel tank expands when warm and may emerge if overfilled. Follow the instructions on refueling.



Warning

Danger of poisoning Fuel is poisonous and a health hazard.

- Fuel must not come into contact with the skin, eyes, or clothing. Do not breathe in the fuel vapors. If contact occurs with the eyes, rinse with water immediately and contact a physician. Immediately clean contaminated areas on the skin with soap and water. If fuel is swallowed, contact a physician immediately. Change clothing that is contaminated with fuel. Store fuel properly in a suitable canister and keep away from children.



Warning

Environmental hazard Improper handling of fuel is a danger to the environment.

- Do not allow fuel to get into the ground water, the ground, or the sewage system.

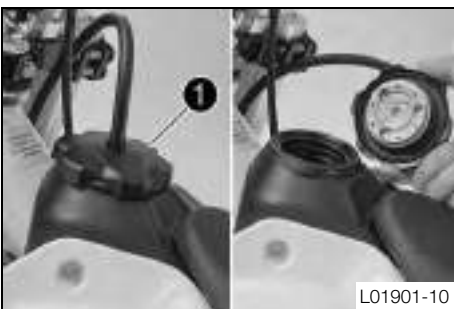

L01901-10

- Turn filler cap ❶ counterclockwise and lift it off.

6.7 Closing the filler cap



L01902-10

- Mount filler cap ❶ and turn it clockwise until the fuel tank is tightly closed.



Info

Run the fuel tank breather hose ❷ without kinks.

6.8 Fuel tap



The fuel tap is on the left side of the fuel tank.

With tap handle ① on the fuel tap, you can open or close the supply of fuel to the carburetor.

Possible states

- Fuel supply closed **OFF** – Fuel cannot flow from the fuel tank to the carburetor.
- Fuel supply open **ON** – Fuel can flow from the fuel tank to the carburetor. The fuel tank empties fully.

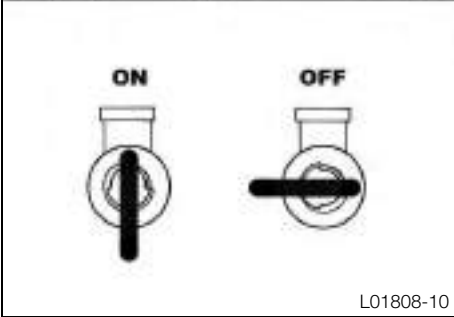

6.9 Choke

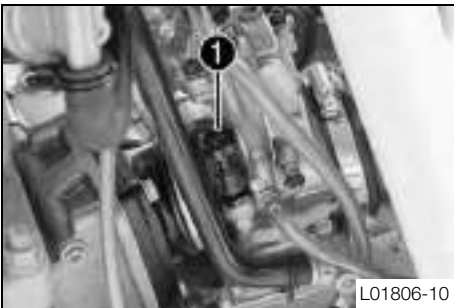

The choke ① is fitted on the left side of the carburetor.

Activating the choke function frees an opening in the carburetor through which the engine can draw extra fuel. This creates a richer fuel-air mixture, as is required for a cold start.

Info

If the engine is warm, the choke function must be deactivated.

Possible states

- Choke function activated – The choke lever is pulled out to the stop.
- Choke function deactivated – The choke lever is pushed in to the stop.

6.10 Shift lever

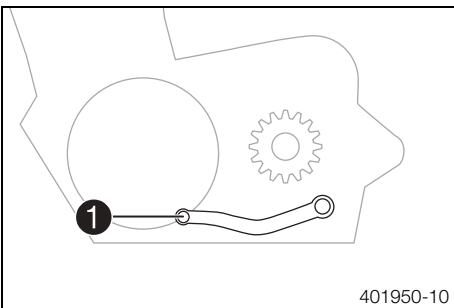

Shift lever ① is mounted on the left side of the engine.

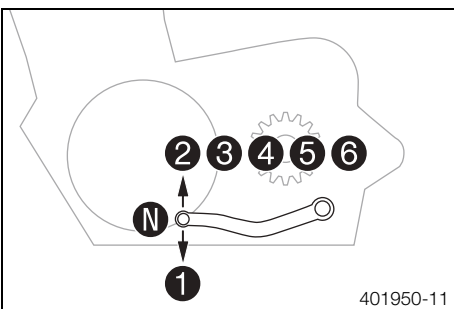

(125 TC EU)

The gear positions can be seen in the photograph.

The neutral or idle position is between the first and second gears.

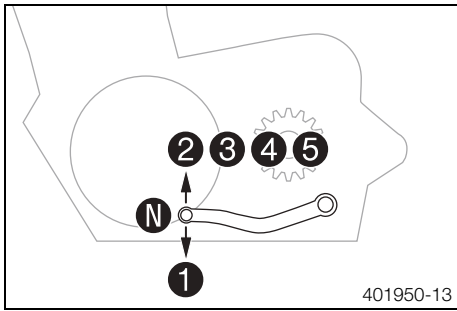

(250 TC EU)

The gear positions can be seen in the photograph.
The neutral or idle position is between the first and second gears.

6.11 Kick starter



The kick starter ❶ is fitted on the right side of the engine. The top part can be swiveled.

6.12 Foot brake lever



Foot brake lever ❶ is located in front of the right footrest.
The foot brake lever is used to activate the rear brake.

6.13 Plug-in stand

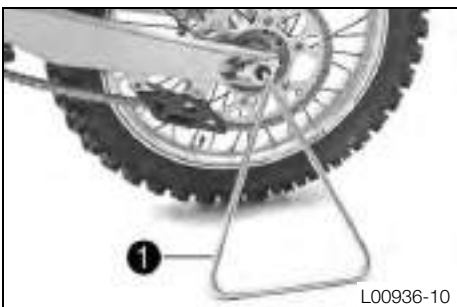

The holder for plug-in stand ❶ is on the left side of the wheel spindle.
The plug-in stand is used to park the motorcycle.

i Info

Remove the plug-in stand before riding.

7.1 Advice on first use



Danger

Danger of accidents Danger arising from the rider's judgement being impaired.

- Do not operate the vehicle while under the influence of alcohol, drugs and certain medications or physically or mentally impaired.



Warning

Risk of injury Missing or poor protective clothing presents an increased safety risk.

- Wear protective clothing (helmet, boots, gloves, pants and jacket with protectors) every time you ride the vehicle. Always wear protective clothing that is in good condition and meets the legal requirements.



Warning

Danger of crashing Poor vehicle handling due to different tire tread patterns on front and rear wheels.

- The front and rear wheels must be fitted with tires with similar tread patterns to prevent loss of control over the vehicle.



Warning

Danger of accidents Critical riding behavior due to inappropriate riding.

- Adapt your riding speed to the road conditions and your riding ability.



Warning

Danger of accidents Accident risk caused by presence of a passenger.

- Your vehicle is not designed to carry passengers. Do not ride with a passenger.



Warning

Danger of accidents Failure of brake system.

- If the foot brake lever is not released, the brake linings drag continuously. The rear brake may fail due to overheating. Take your foot off the foot brake lever when you are not braking.



Warning

Danger of accidents Unstable riding behavior.

- Do not exceed the maximum permissible weight and axle loads.



Warning

Risk of misappropriation Usage by unauthorized persons.

- Never leave the vehicle while the engine is running. Secure the vehicle against use by unauthorized persons.



Info

When using your motorcycle, remember that others may feel disturbed by excessive noise.

- Make sure that the pre-delivery inspection work has been carried out by an authorized Husqvarna workshop.
 - ✓ You receive a delivery certificate and the service record at vehicle handover.
- Before your first trip, read the entire operating instructions carefully.
- Get to know the controls.
- Adjust the basic position of the clutch lever. (☞ p. 52)
- Adjust the basic position of the hand brake lever. (☞ p. 56)
- Adjust the basic position of the foot brake lever. (☞ p. 60)
- Adjust the basic position of the shift lever. (☞ p. 79)
- Become accustomed to the handling of the motorcycle on suitable terrain.



Info

Your motorcycle is not authorized for riding on public roads.

Offroad, you should be accompanied by another person on another machine so that you can help each other.

- Try also to ride as slowly as possible and in a standing position to get a better feeling for the vehicle.
- Do not make any offroad trips that over-stress your ability and experience.
- Hold the handlebar firmly with both hands and keep your feet on the footrests when riding.
- Do not transport luggage.

- Do not exceed the overall maximum permitted weight and the axle loads.

Guideline

Maximum permissible overall weight	335 kg (739 lb.)
Maximum permissible front axle load	145 kg (320 lb.)
Maximum permissible rear axle load	190 kg (419 lb.)

- Check the spoke tension. (☛ p. 68)



Info

The spoke tension must be checked after half an hour of operation.

- Run in the engine. (☛ p. 16)

7.2 Running in the engine

- During the running-in phase, do not exceed the specified engine performance.

Guideline

Maximum engine performance	
During the first 3 operating hours	< 70 %
During the first 5 operating hours	< 100 %

- Avoid fully opening the throttle!

7.3 Preparing the vehicle for difficult riding conditions



Info

Use of the vehicle under difficult conditions, such as on sand or on wet and muddy surfaces, can lead to considerably more rapid wear of components such as the drive train, brake system, or suspension components. For this reason, it may be necessary to inspect or replace parts before the next scheduled service.

- Seal the air filter box. ☛ (☛ p. 44)
- Clean the air filter and air filter box. ☛ (☛ p. 43)



Info

Check the air filter approx. every 30 minutes.

- Additionally secure the rubber grip. (☛ p. 52)
- Check the electrical connector for humidity and corrosion and to ensure it is firmly seated.
 - » If humidity, corrosion, or damage is found:
 - Clean and dry the connector, or change it if necessary.

Difficult riding conditions are:

- Riding on dry sand. (☛ p. 16)
- Riding on wet sand. (☛ p. 17)
- Riding on wet and muddy surfaces. (☛ p. 18)
- Riding at high temperatures and low speeds. (☛ p. 18)
- Riding at low temperatures or in snow. (☛ p. 19)

7.4 Preparations for riding on dry sand



- Check the radiator cap.

Value on the radiator cap	1.8 bar (26 psi)
---------------------------	------------------

- » If the displayed value does not equal the setpoint value:



Warning

Danger of scalding During motorcycle operation, the coolant gets very hot and is under pressure.

- Do not remove the radiator cap, radiator hoses or other cooling system components when the engine is hot. Allow the engine and cooling system to cool down. In case of scalding, rinse immediately with lukewarm water.



- Change the radiator cap.
- Mount the dust cover for the air filter.

Dust cover for air filter (77206920100)

i Info
Observe the **Husky Power** fitting instructions.



- Mount the dust cover for the air filter for sand.

Sand cover for air filter (59006922000)

i Info
Observe the **Husky Power** fitting instructions.

- Adjust the carburetor jetting and setting.

i Info
The recommended carburetor tuning is available from your authorized Husqvarna workshop.



- Clean the chain.
- Mount the steel sprocket.

i Tip
Do not grease the chain.

- Clean the radiator fins.
- Carefully align bent radiator fins.
- If used in sand regularly, replace the piston every 10 operating hours.

7.5 Preparations for riding on wet sand



- Check the radiator cap.

Value on the radiator cap	1.8 bar (26 psi)
---------------------------	------------------

» If the displayed value does not equal the setpoint value:

! Warning
Danger of scalding During motorcycle operation, the coolant gets very hot and is under pressure.

- Do not remove the radiator cap, radiator hoses or other cooling system components when the engine is hot. Allow the engine and cooling system to cool down. In case of scalding, rinse immediately with lukewarm water.

- Change the radiator cap.

- Mount the rain cover for the air filter.

Rain cover for air filter (77206921100)

i Info
Observe the **Husky Power** fitting instructions.

- Adjust the carburetor jetting and setting.

i Info
The recommended carburetor tuning is available from your authorized Husqvarna workshop.





600868-01

- Clean the chain.
- Mount the steel sprocket.

i Tip
Do not grease the chain.

- Clean the radiator fins.
- Carefully align bent radiator fins.
- If used in sand regularly, replace the piston every 10 operating hours.

7.6 Preparations for riding on wet and muddy surfaces



B00437-01

- Mount the rain cover for the air filter.

Rain cover for air filter (77206921100)

i Info
Observe the **Husky Power** fitting instructions.

- Adjust the carburetor jetting and setting.

i Info
The recommended carburetor tuning is available from your authorized Husqvarna workshop.



600868-01

- Mount the steel sprocket.
- Clean the motorcycle. (☛ p. 85)
- Carefully align bent radiator fins.

7.7 Preparations for riding at high temperatures and low speeds



600872-10

- Check the radiator cap.

Value on the radiator cap	1.8 bar (26 psi)
---------------------------	------------------

» If the displayed value does not equal the setpoint value:

! Warning
Danger of scalding During motorcycle operation, the coolant gets very hot and is under pressure.

- Do not remove the radiator cap, radiator hoses or other cooling system components when the engine is hot. Allow the engine and cooling system to cool down. In case of scalding, rinse immediately with lukewarm water.

- Change the radiator cap.

- Adjust the secondary ratio to the terrain.

i Info
The engine oil heats up quickly when the clutch is operated frequently due to an excessively high secondary drive.



600868-01

- Clean the chain.
- Clean the radiator fins.
- Carefully align bent radiator fins.
- Check the coolant level. (☛ p. 72)

7.8 Preparing for riding at low temperatures or in snow



- Mount the rain cover for the air filter.

Rain cover for air filter (77206921100)



Info

Observe the **Husky Power** fitting instructions.

- Adjust the carburetor jetting and setting.



Info

The recommended carburetor tuning is available from your authorized Husqvarna workshop.

8.1 Checks and maintenance work when preparing for use

Info

Before riding the vehicle, always check its condition and operating safety.
The vehicle must be in perfect technical condition when used.

- Check the gear oil level. (🔧 p. 81)
- Check the front brake fluid level. (🔧 p. 57)
- Check the rear brake fluid level. (🔧 p. 61)
- Check the front brake linings. (🔧 p. 58)
- Check the rear brake linings. (🔧 p. 62)
- Check that the brake system is functioning properly.
- Check the coolant level. (🔧 p. 72)
- Check the chain for dirt. (🔧 p. 47)
- Check the chain, rear sprocket, engine sprocket and chain guide. (🔧 p. 49)
- Check the chain tension. (🔧 p. 48)
- Check the tire condition. (🔧 p. 67)
- Check the tire air pressure. (🔧 p. 68)
- Check the spoke tension. (🔧 p. 68)
- Clean the dust boots of the fork legs. (🔧 p. 33)
- Bleed the fork legs. (🔧 p. 33)
- Check the air filter.
- Check the settings of all controls and ensure that they can be operated smoothly.
- Check all screws, nuts and hose clamps regularly for tightness.
- Check the fuel supply.

8.2 Starting

Danger

Danger of poisoning Exhaust gases are toxic and inhaling them may result in unconsciousness and/or death.

- When running the engine, always make sure there is sufficient ventilation, and do not start or run the engine in an enclosed space without an effective exhaust extraction system.

Note

Engine failure High engine speeds in cold engines have a negative effect on the service life of the engine.

- Always warm up the engine at low engine speeds.

Info

If the motorcycle is unwilling to start, the cause can be old fuel in the float chamber. The flammable elements of the fuel evaporate after a long time of standing.

If the float chamber is filled with fresh fuel, the engine starts immediately.

Engine has been out of use for more than 1 week

- Empty the carburetor float chamber. (🔧 p. 77)
- Turn handle  1 of the fuel tap to the **ON** position. (Figure L01808-10🔧 p. 13)
 - ✓ Fuel can flow from the fuel tank to the carburetor.
- Remove the motorcycle from the stand.
- Shift gear to neutral.

The engine is cold

- Pull choke lever out as far as possible.
- Press the kick starter forcefully through its full range.

Info

Do not open the throttle.

8.3 Starting off



Info

The plug-in stand must be removed before riding.
When you are riding, the side stand must be folded up and secured with the rubber band.

- Pull the clutch lever, engage 1st gear, release the clutch lever slowly and simultaneously open the throttle carefully.

8.4 Shifting, riding



Warning

Danger of accidents If you change down at high engine speed, the rear wheel can lock up.

- Do not change into a low gear at high engine speed. The engine races and the rear wheel can lock up.



Info

If you hear unusual noises while riding, stop immediately, switch off the engine, and contact an authorized Husqvarna workshop. First gear is used for starting off or for steep inclines.

- When conditions allow (incline, road situation, etc.), you can shift into a higher gear. To do so, release the throttle while simultaneously pulling the clutch lever, shift into the next gear, release the clutch and open the throttle.
- If the choke function was activated, deactivate it after the engine has warmed up.
- When you reach maximum speed after fully opening the throttle, turn back the throttle to about $\frac{3}{4}$ of its range. This barely reduces vehicle speed but lowers fuel consumption considerably.
- Always open the throttle only as much as the engine can handle – abrupt throttle opening increases fuel consumption.
- To shift down, brake and close the throttle at the same time.
- Pull the clutch lever and shift into a lower gear, release the clutch lever slowly and open the throttle or shift again.
- Switch off the engine if you expect to be standing for a long time.

Guideline

≥ 2 min

- Avoid frequent and longer slipping of the clutch. This heats the engine oil, the engine and the cooling system.
- Ride with a lower engine speed instead of with a high engine speed and a slipping clutch.

8.5 Braking



Warning

Danger of accidents If you brake too hard, the wheels can lock.

- Adapt your braking to the traffic situation and the road conditions.



Warning

Danger of accidents Reduced braking efficiency caused by spongy pressure point of front or rear brake.

- Check the brake system and do not continue riding. (Your authorized Husqvarna workshop will be glad to help.)



Warning

Danger of accidents Reduced braking efficiency due to a wet or dirty brake system.

- Clean or dry a dirty or wet brake system by riding and braking gently.

- On sandy, wet or slippery surfaces, use the rear brake.
- Braking should always be completed before you go into a bend. Change down to a lower gear appropriate to your road speed.
- Make use of the braking effect of the engine when driving down long downhill stretches. To do so, shift back one or two gears, but do not overrev the engine. You will need to apply the brakes far less often and the brake system will not overheat.

8.6 Stopping, parking



Warning

Risk of misappropriation Usage by unauthorized persons.

- Never leave the vehicle while the engine is running. Secure the vehicle against use by unauthorized persons.



Warning

Danger of burns Some vehicle components become very hot when the vehicle is operated.

- Do not touch hot components such as exhaust system, radiator, engine, shock absorber, and the brake system. Allow these components to cool down before starting work on them.

Note

Danger of damage The parked vehicle may roll away or fall over.

- Always place the vehicle on a firm and even surface.

Note



Fire hazard Some vehicle components become very hot when the vehicle is operated.

- Do not park the vehicle near flammable or explosive substances. Do not place objects on the vehicle while it is still warm from being run. Always let the vehicle cool first.

Note

Material damage Damage to or destruction of components due to excessive load.

- The side stand is only designed for the weight of the motorcycle. Do not sit on the motorcycle when it is resting on the side stand. The side stand or the frame may become damaged and the motorcycle may fall over.

-
- Brake the motorcycle.
 - Shift gear to neutral.
 - Press and hold the kill switch  while the engine is idling until the engine stops.
 - Turn handle  of the fuel tap to the **OFF** position. (Figure L01808-10  p. 13)
 - Park the vehicle on the side stand.

8.7 Transport

Note

Danger of damage The parked vehicle may roll away or fall over.

- Always place the vehicle on a firm and even surface.

Note

Fire hazard Some vehicle components become very hot when the vehicle is operated.

- Do not park the vehicle near flammable or explosive substances. Do not place objects on the vehicle while it is still warm from being run. Always let the vehicle cool first.

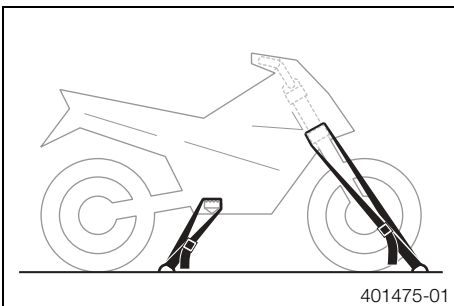

- Switch off the engine.
- Use tension belts or other suitable devices to secure the motorcycle against accidents or falling over.

8.8 Refueling



Danger

Fire hazard Fuel is highly flammable.

- Never refuel the vehicle near open flames or burning cigarettes, and always switch off the engine first. Be careful that no fuel is spilt, especially on hot vehicle components. Clean up spilt fuel immediately.
- The fuel in the fuel tank expands when warm and may emerge if overfilled. Follow the instructions on refueling.



Warning

Danger of poisoning Fuel is poisonous and a health hazard.

- Fuel must not come into contact with the skin, eyes, or clothing. Do not breathe in the fuel vapors. If contact occurs with the eyes, rinse with water immediately and contact a physician. Immediately clean contaminated areas on the skin with soap and water. If fuel is swallowed, contact a physician immediately. Change clothing that is contaminated with fuel.



Warning

Environmental hazard Improper handling of fuel is a danger to the environment.

- Do not allow fuel to get into the ground water, the ground, or the sewage system.

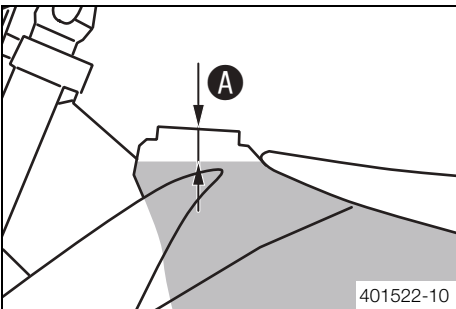

- Switch off the engine.
- Open the filler cap. (☛ p. 12)
- Fill the fuel tank with fuel up to measurement **A**.

Guideline

Measurement of A	35 mm (1.38 in)	
Total fuel tank capacity, approx.	7.5 l (1.98 US gal)	Super unleaded (98 octane) mixed with 2-stroke engine oil (1:40) (☛ p. 101) (125 TC EU)
		Super unleaded (95 octane) mixed with 2-stroke engine oil (1:60) (☛ p. 101) (250 TC EU)
Engine oil, 2-stroke (☛ p. 100)		

- Close the filler cap. (☛ p. 12)

9.1 Service schedule

Every 30 operating hours - corresponds to about 210 liters of fuel (55.5 US gal)			
Every 20 operating hours - corresponds to about 140 liters of fuel (37 US gal)			
Every 10 operating hours - corresponds to about 70 liters of fuel (18.5 US gal) / after every race			
Change the gear oil. 🛠️ (125 TC EU)	•	•	•
Change the gear oil. 🛠️ (250 TC EU)		•	
Check the front brake linings. (📖 p. 58)	•	•	•
Check the rear brake linings. (📖 p. 62)	•	•	•
Check the brake discs. (📖 p. 56)	•	•	•
Check the brake lines for damage and leakage.	•	•	•
Check the rear brake fluid level. (📖 p. 61)	•	•	•
Check the free travel of the foot brake lever. (📖 p. 60)	•	•	•
Check the frame and swingarm. 🛠️	•	•	•
Check the swingarm bearing. 🛠️		•	
Check the shock absorber linkage. 🛠️	•	•	•
Conduct a minor fork service. 🛠️	•	•	•
Conduct a major fork service. 🛠️			•
Check the tire condition. (📖 p. 67)	•	•	•
Check the tire air pressure. (📖 p. 68)	•	•	•
Check the wheel bearing for play. 🛠️	•	•	•
Check the wheel hubs. 🛠️	•	•	•
Check the rim run-out. 🛠️	•	•	•
Check the spoke tension. (📖 p. 68)	•	•	•
Check the chain, rear sprocket, engine sprocket and chain guide. (📖 p. 49)	•	•	•
Check the chain tension. (📖 p. 48)	•	•	•
Grease all moving parts (e.g., hand lever, chain, ...) and check for smooth operation. 🛠️	•	•	•
Check/correct the fluid level of the hydraulic clutch. (📖 p. 53)	•	•	•
Check the front brake fluid level. (📖 p. 57)	•	•	•
Check the free travel of the hand brake lever. (📖 p. 56)	•	•	•
Check the play of the steering head bearing. (📖 p. 38)	•	•	•
Change the piston and check the cylinder. 🛠️		•	
Change the piston and check the cylinder. (under difficult riding conditions) 🛠️	•	•	•
Change the spark plug and spark plug connector. 🛠️ (125 TC EU)	•	•	•
Change the spark plug and spark plug connector. 🛠️ (250 TC EU)		•	
Check the intake diaphragm. 🛠️	•	•	•
Check the exhaust control for functioning and smooth operation. 🛠️		•	
Check the clutch. 🛠️	•	•	•
Check all hoses (e. g. fuel, cooling, bleeding, drainage) and sleeves for cracking, leaks, and incorrect routing. 🛠️	•	•	•
Check the antifreeze and coolant level. (📖 p. 71)	•	•	•
Check the cables for damage and routing without sharp bends. 🛠️	•	•	•
Check that the throttle cables are undamaged, routed without sharp bends and set correctly.	•	•	•
Clean the air filter and air filter box. 🛠️ (📖 p. 43)	•	•	•
Change the glass fiber yarn filling of the main silencer. 🛠️ (📖 p. 44)		•	
Check the screws and nuts for tightness. 🛠️	•	•	•
Check the idle. 🛠️	•	•	•
Final check: Check the vehicle for safe operation and take a test ride.	•	•	•
Make the service entry in Husqvarna Dealer.net and in the service booklet. 🛠️	•	•	•

- Periodic interval

9.2 Service work (as additional order)

	Annually	
Every 40 operating hours - corresponds to about 280 liters of fuel (74 US gal)		
Once after 20 operating hours		
Change the front brake fluid. 🛠️		•
Change the rear brake fluid. 🛠️		•
Change the hydraulic clutch fluid. 🛠️ (🔧 p. 54)		•
Grease the steering head bearing. 🛠️ (🔧 p. 39)		•
Check/set the carburetor components. 🛠️		• •
Service the shock absorber. 🛠️	○	•
Change the connecting rod, conrod bearing and crank pin. 🛠️		•
Check the transmission and shift mechanism. 🛠️		•
Change all engine bearings. 🛠️		•

- One-time interval
- Periodic interval

10.1 Checking the basic chassis setting with the rider's weight

i Info

When adjusting the basic chassis setting, first adjust the shock absorber and then the fork.

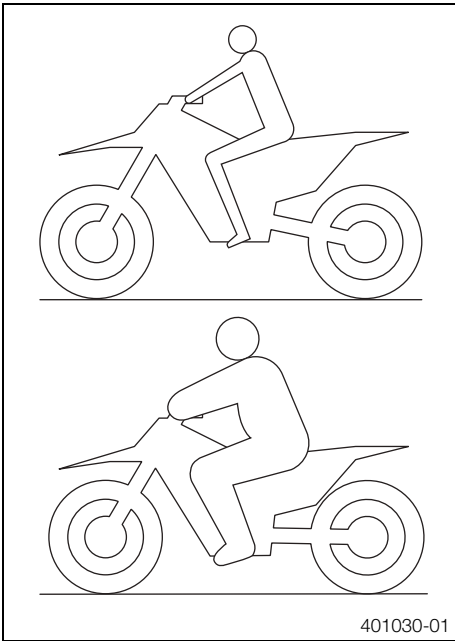

401030-01

- For optimal motorcycle riding characteristics and to avoid damage to forks, shock absorbers, swingarm and frame, the basic settings of the suspension components must match the rider's weight.
- As delivered, Husqvarna offroad motorcycles are adjusted for an average rider's weight (with full protective clothing).

Guideline

Standard rider weight	75... 85 kg (165... 187 lb.)
-----------------------	------------------------------

- If the rider's weight is above or below the standard range, the basic setting of the suspension components must be adjusted accordingly.
- Small weight differences can be compensated by adjusting the spring preload, but in the case of large weight differences, the springs must be replaced.

10.2 Compression damping of shock absorber

The compression damping of the shock absorber is divided into two ranges: high-speed and low-speed.

High-speed and low-speed refer to the compression speed of the rear wheel suspension and not to the vehicle speed.

The high-speed setting, for example, affects the compression when landing after a jump: the rear wheel suspension compresses more quickly.

The low-speed setting, for example, affects the compression when riding over long ground swells: the rear wheel suspension compresses more slowly.

These two ranges can be adjusted separately, although the transition between high-speed and low-speed is gradual. Thus, changes in the high-speed range affect the compression damping in the low-speed range and vice versa.

10.3 Adjusting the low-speed compression damping of the shock absorber

⚠ Caution

Danger of accidents Disassembly of pressurized parts can lead to injury.

- The shock absorber is filled with high density nitrogen. Adhere to the description provided. (Your authorized Husqvarna workshop will be glad to help.)

i Info

The low-speed setting can be seen during the slow to normal compression of the shock absorber.



L01620-10

- Turn adjusting screw ① clockwise with a screwdriver up to the last perceptible click.

i Info

Do not loosen fitting ②.

- Turn counterclockwise by the number of clicks corresponding to the shock absorber type.

Guideline

Compression damping, low-speed (125 TC EU)	
Comfort	17 clicks
Standard	15 clicks
Sport	13 clicks
Compression damping, low-speed (250 TC EU)	
Comfort	17 clicks
Standard	15 clicks
Sport	13 clicks

i Info
Turn clockwise to increase damping; turn counterclockwise to reduce damping.

10.4 Adjusting the high-speed compression damping of the shock absorber

! Caution
Danger of accidents Disassembly of pressurized parts can lead to injury.

- The shock absorber is filled with high density nitrogen. Adhere to the description provided. (Your authorized Husqvarna workshop will be glad to help.)

i Info
The high-speed setting can be seen during the fast compression of the shock absorber.



- Turn adjusting screw **1** all the way clockwise with a socket wrench.

i Info
Do not loosen fitting **2**.

- Turn counterclockwise by the number of turns corresponding to the shock absorber type.

Guideline

Compression damping, high-speed (125 TC EU)	
Comfort	2.5 turns
Standard	2 turns
Sport	1.5 turns
Compression damping, high-speed (250 TC EU)	
Comfort	2.5 turns
Standard	2 turns
Sport	1.5 turns

i Info
Turn clockwise to increase damping; turn counterclockwise to reduce damping.

10.5 Adjusting the rebound damping of the shock absorber

! Caution
Danger of accidents Disassembly of pressurized parts can lead to injury.

- The shock absorber is filled with high density nitrogen. Adhere to the description provided. (Your authorized Husqvarna workshop will be glad to help.)

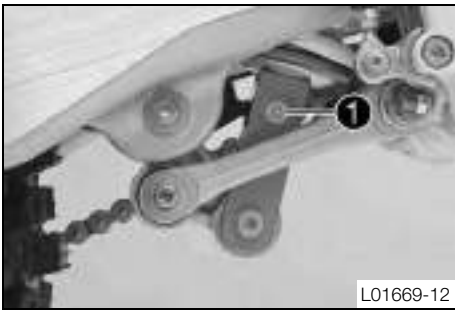

- Turn adjusting screw ① clockwise up to the last perceptible click.
- Turn counterclockwise by the number of clicks corresponding to the shock absorber type.

Guideline

Rebound damping (125 TC EU)	
Comfort	17 clicks
Standard	15 clicks
Sport	13 clicks
Rebound damping (250 TC EU)	
Comfort	17 clicks
Standard	15 clicks
Sport	13 clicks

i Info
Turn clockwise to increase damping; turn counterclockwise to reduce damping.

10.6 Measuring the sag of the unloaded rear wheel

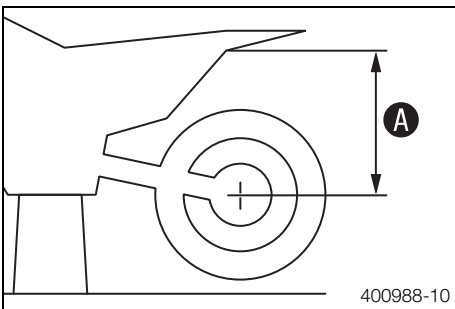

Preparatory work

- Raise the motorcycle with the lift stand. (☞ p. 33)

Main work

- Measure the distance – as vertically as possible – between the rear axle and a fixed point such as a mark on the side cover.
- Note down the value as dimension ①.

Finishing work

- Remove the motorcycle from the lift stand. (☞ p. 33)

10.7 Checking the static sag of the shock absorber

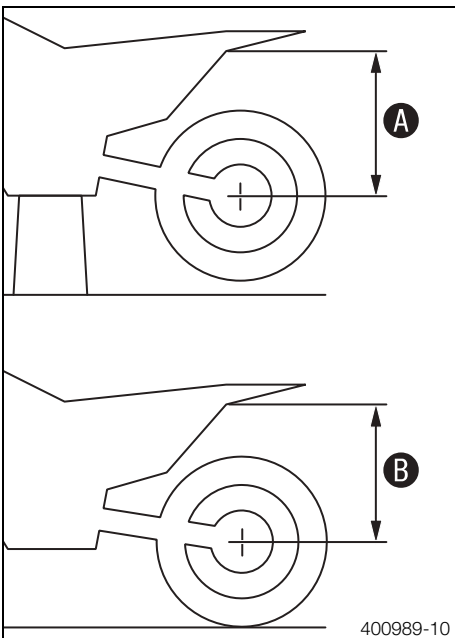

- Measure distance ① of the unloaded rear wheel. (☞ p. 28)
- Hold the motorcycle upright with the aid of an assistant.
- Measure the distance between the rear axle and the fixed point again.
- Note down the value as dimension ②.

i Info
The static sag is the difference between measurements ① and ②.

- Check the static sag.

Static sag (125 TC EU)	30 mm (1.18 in)
Static sag (250 TC EU)	30 mm (1.18 in)

- » If the static sag is less or more than the specified value:
 - Adjust the spring preload of the shock absorber. ☞ (☞ p. 29)

10.8 Checking the riding sag of the shock absorber

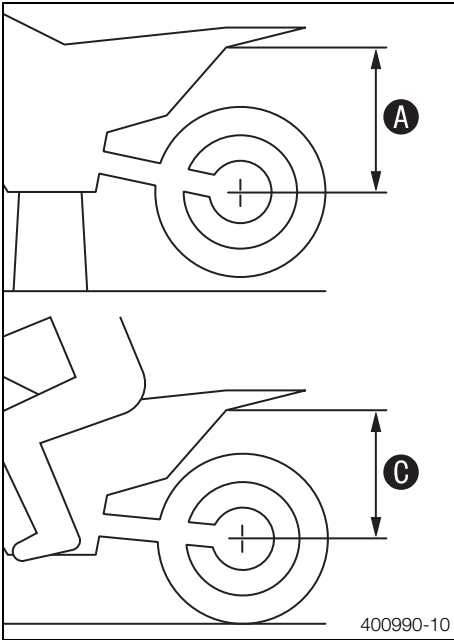

- Measure distance **A** of the unloaded rear wheel. (☞ p. 28)
- With another person holding the motorcycle, the rider, wearing full protective clothing, sits on the seat in a normal sitting position (feet on footrests) and bounces up and down a few times.
 - ✓ The rear wheel suspension levels out.
- Another person now measures the distance between the rear axle and the fixed point.
- Note down the value as dimension **C**.

i Info

The riding sag is the difference between measurements **A** and **C**.

- Check the riding sag.

Guideline

Riding sag (125 TC EU)	100 mm (3.94 in)
Riding sag (250 TC EU)	100 mm (3.94 in)

» If the riding sag differs from the specified measurement:

- Adjust the riding sag. ☞ (☞ p. 30)

10.9 Adjusting the spring preload of the shock absorber ☞

! Caution

Danger of accidents Disassembly of pressurized parts can lead to injury.

- The shock absorber is filled with high density nitrogen. Adhere to the description provided. (Your authorized Husqvarna workshop will be glad to help.)

i Info

Before changing the spring preload, make a note of the present setting, e.g., by measuring the length of the spring.

Preparatory work

- Raise the motorcycle with the lift stand. (☞ p. 33)
- Remove the right side cover. (☞ p. 45)
- Remove the main silencer. (☞ p. 44)
- Remove the shock absorber. ☞ (☞ p. 41)
- After removing the shock absorber, clean it thoroughly.

Main work

- Loosen screw **1**.
- Turn adjusting ring **2** until the spring is no longer under tension.

Hook wrench (T106S)

- Measure the overall spring length while the spring is not under tension.
- Tighten the spring by turning adjusting ring **2** to measurement **A**.

Guideline

Spring preload (125 TC EU)	12 mm (0.47 in)
Spring preload (250 TC EU)	12 mm (0.47 in)

i Info

Depending on the static sag and/or the riding sag, it may be necessary to increase or decrease the spring preload.

- Tighten screw **1**.

Guideline

Screw, shock absorber adjusting ring	M5	5 Nm (3.7 lbf ft)
--------------------------------------	----	-------------------



401025-10

Finishing work

- Install the shock absorber. (🔧 p. 41)
- Install the main silencer. (🔧 p. 44)
- Install the right side cover. (🔧 p. 45)
- Remove the motorcycle from the lift stand. (🔧 p. 33)

10.10 Adjusting the riding sag 🛠️

Preparatory work

- Raise the motorcycle with the lift stand. (🔧 p. 33)
- Remove the right side cover. (🔧 p. 45)
- Remove the main silencer. (🔧 p. 44)
- Remove the shock absorber. 🛠️ (🔧 p. 41)
- After removing the shock absorber, clean it thoroughly.

Main work

- Choose and mount a suitable spring.

Guideline

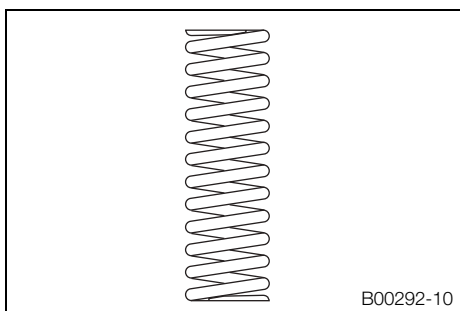

Spring rate (125 TC EU)	
Weight of rider: 65... 75 kg (143... 165 lb.)	45 N/mm (257 lb/in)
Weight of rider: 75... 85 kg (165... 187 lb.)	48 N/mm (274 lb/in)
Weight of rider: 85... 95 kg (187... 209 lb.)	51 N/mm (291 lb/in)
Spring rate (250 TC EU)	
Weight of rider: 65... 75 kg (143... 165 lb.)	51 N/mm (291 lb/in)
Weight of rider: 75... 85 kg (165... 187 lb.)	54 N/mm (308 lb/in)
Weight of rider: 85... 95 kg (187... 209 lb.)	57 N/mm (325 lb/in)



Info

The spring rate is shown on the outside of the spring.

Finishing work

- Install the shock absorber. 🛠️ (🔧 p. 41)
- Install the main silencer. (🔧 p. 44)
- Install the right side cover. (🔧 p. 45)
- Remove the motorcycle from the lift stand. (🔧 p. 33)
- Check the static sag of the shock absorber. (🔧 p. 28)
- Check the riding sag of the shock absorber. (🔧 p. 29)
- Adjust the rebound damping of the shock absorber. (🔧 p. 27)

10.11 Checking the basic setting of the fork



Info

For various reasons, no exact riding sag can be determined for the forks.

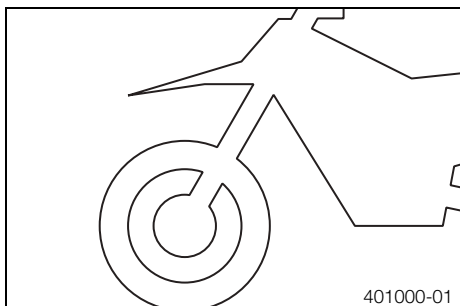

- As with the shock absorber, smaller differences in the rider's weight can be compensated by the spring preload.
- However, if the fork is often overloaded (hard end stop on compression), harder springs must be fit to avoid damage to the fork and frame.

10.12 Adjusting the compression damping of the fork

i Info
The hydraulic compression damping determines the fork suspension behavior.



- Turn adjusting screws ❶ clockwise all the way.

i Info
Adjusting screws ❶ are located at the top end of the fork legs. Make the same adjustment on both fork legs.

- Turn counterclockwise by the number of clicks corresponding to the fork type.

Guideline

Compression damping (125 TC EU)	
Comfort	14 clicks
Standard	12 clicks
Sport	10 clicks
Compression damping (250 TC EU)	
Comfort	14 clicks
Standard	12 clicks
Sport	10 clicks

i Info
Turn clockwise to increase damping; turn counterclockwise to reduce damping.

- Mount protection caps ❶.

10.13 Adjusting the rebound damping of the fork

i Info
The hydraulic rebound damping determines the fork suspension behavior.

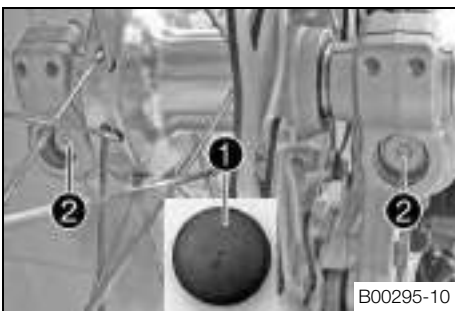

- Remove protection caps ❶.
- Turn adjusting screws ❷ clockwise all the way.

i Info
Adjusting screws ❷ are located at the bottom end of the fork legs. Make the same adjustment on both fork legs.

- Turn counterclockwise by the number of clicks corresponding to the fork type.

Guideline

Rebound damping (125 TC EU)	
Comfort	14 clicks
Standard	12 clicks
Sport	10 clicks
Rebound damping (250 TC EU)	
Comfort	14 clicks
Standard	12 clicks
Sport	10 clicks

i Info
Turn clockwise to increase damping; turn counterclockwise to reduce damping.

- Mount protection caps ❶.

10.14 Handlebar position

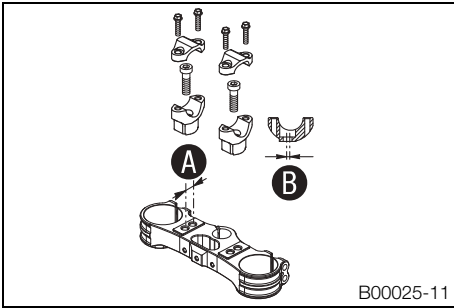

On the upper triple clamp, there are two holes a distance of **A** apart.

Hole distance A	15 mm (0.59 in)
-----------------	-----------------

The holes on the handlebar support are placed at a distance of **B** from the center.

Hole distance B	3.5 mm (0.138 in)
-----------------	-------------------

The handlebar can be mounted in four different positions. In this way, the handlebar can be mounted in the position that is most comfortable for the rider.

10.15 Adjusting the handlebar position



Warning

Danger of accidents Handlebar breakage.

- If the handlebar is bent or straightened it will cause material fatigue, and the handlebar can break. Always replace handlebar.

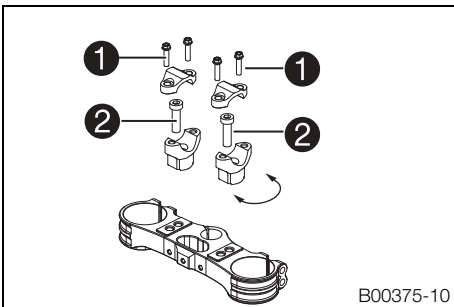

- Remove screws **1**. Remove the handlebar clamp. Remove the handlebar and lay it to one side.



Info

Protect the motorcycle and its attachments against damage by covering them.
Do not bend the cables and lines.

- Remove screws **2**. Remove the handlebar support.
- Place the handlebar support in the required position. Mount and tighten screws **2**.

Guideline

Screw, handlebar support	M10	40 Nm (29.5 lbf ft)	Loctite® 243™
--------------------------	-----	------------------------	----------------------



Info

Position the left and right handlebar supports evenly.

- Position the handlebar.



Info

Make sure cables and wiring are positioned correctly.

- Position the handlebar clamps. Mount screws **1** and tighten evenly.

Guideline

Screw, handlebar clamp	M8	20 Nm (14.8 lbf ft)
------------------------	----	---------------------



Info

Make sure the gap widths are even.

11.1 Raising the motorcycle with the lift stand

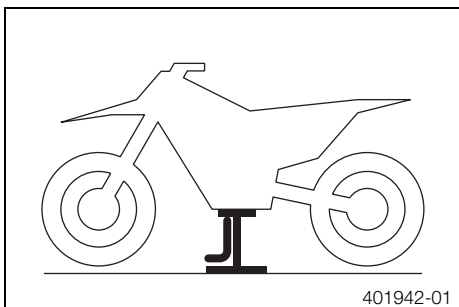

- Raise the motorcycle at the frame below the engine.
 - ✓ The wheels should no longer touch the ground.
- Secure the motorcycle against falling over.

Lift stand (54829055000)

11.2 Removing the motorcycle from the lift stand

Note

Danger of damage The parked vehicle may roll away or fall over.

- Always place the vehicle on a firm and even surface.

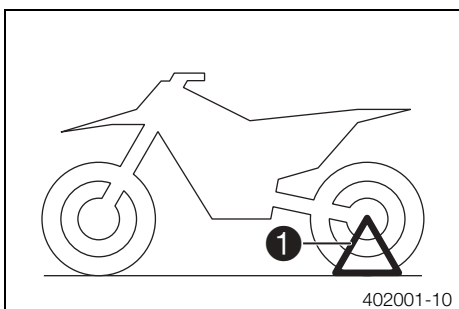

- Remove the motorcycle from the lift stand.
- Remove the lift stand.
- To park the motorcycle, insert plug-in stand ❶ into the left side of the wheel spindle.

Info

Remove the plug-in stand before riding.

11.3 Bleeding the fork legs



Preparatory work

- Raise the motorcycle with the lift stand. (☞ p. 33)

Main work

- Release bleeder screws ❶.
 - ✓ Any excess pressure escapes from the interior of the fork.
- Tighten the bleeder screws.

Finishing work

- Remove the motorcycle from the lift stand. (☞ p. 33)

11.4 Cleaning the dust boots of the fork legs



Preparatory work

- Raise the motorcycle with the lift stand. (☞ p. 33)
- Loosen the fork protection. (☞ p. 34)

Main work

- Push dust boots ❶ of both fork legs downwards.

Info

The dust boots remove dust and coarse dirt particles from the inside fork tubes. Over time, dirt can penetrate behind the dust boots. If this dirt is not removed, the oil seals behind can start to leak.



Warning

Danger of accidents Reduced braking efficiency due to oil or grease on the brake discs.

- Always keep the brake discs free of oil and grease, and clean them with brake cleaner when necessary.

- Clean and oil the dust boots and inner fork tube of both fork legs.
- Press the dust boots back into their normal position.
- Remove excess oil.

Finishing work

- Position the fork protection. (☛ p. 34)
- Remove the motorcycle from the lift stand. (☛ p. 33)

11.5 Loosening the fork protection



B01849-10

- Remove screws ❶ and take off the clamp.
- Remove screws ❷ on the left fork leg. Push the fork protection downwards.
- Remove the screws on the right fork leg. Push the fork protection downwards.

11.6 Positioning the fork protection



B01849-11

- Position the fork protection on the left fork leg. Mount and tighten screws ❶.

Guideline

Remaining screws, chassis	M6	10 Nm (7.4 lbf ft)
---------------------------	----	--------------------

- Position the brake line. Position the clamp and mount and tighten screws ❷.
- Position the fork protection on the right fork leg. Mount and tighten the screws.

Guideline

Remaining screws, chassis	M6	10 Nm (7.4 lbf ft)
---------------------------	----	--------------------

11.7 Removing the fork legs ☛

Preparatory work

- Raise the motorcycle with the lift stand. (☛ p. 33)
- Remove the front wheel. ☛ (☛ p. 65)

Main work

- Remove screws ❶ and take off the clamp.
- Remove screws ❷ and take off the brake caliper.
- Allow the brake caliper and brake line to hang tension-free to the side.



Info

Do not activate the hand brake lever while the front wheel is removed.

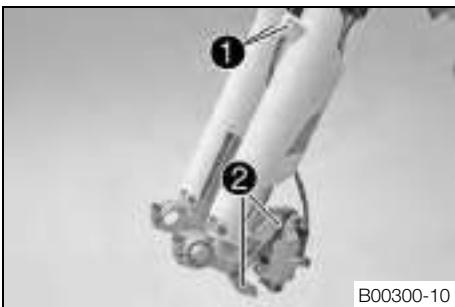

B00300-10

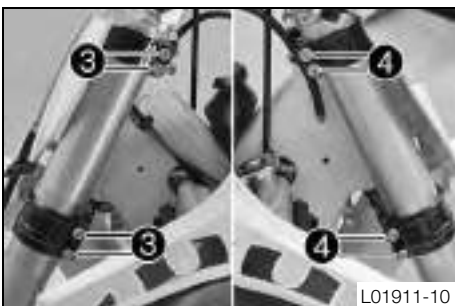

L01911-10

- Unscrew screws ❸. Take out the left fork leg.
- Unscrew screws ❹. Take out the right fork leg.

11.8 Installing the fork legs



L01910-10

Main work

- Position the fork legs.
- ✓ Bleeder screws **1** face forward.

Info

Grooves are milled into the side of the upper end of the fork legs. The second milled groove (from the top) must be flush with the top edge of the upper triple clamp.

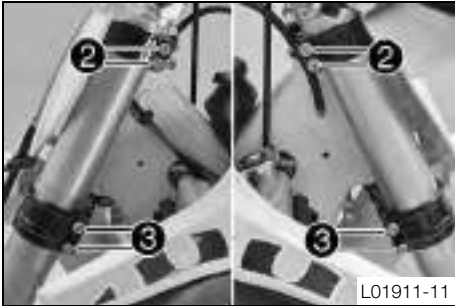

L01911-11

- Tighten screws **2**.

Guideline

Screw, top triple clamp	M8	17 Nm (12.5 lbf ft)
-------------------------	----	---------------------

- Tighten screws **3**.

Guideline

Screw, bottom triple clamp	M8	12 Nm (8.9 lbf ft)
----------------------------	----	--------------------

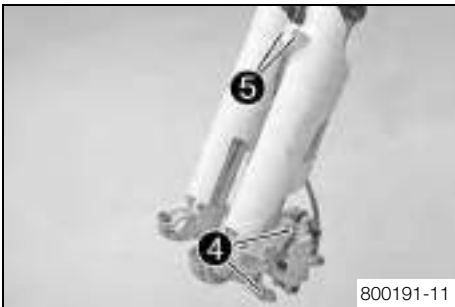

800191-11

- Position the brake caliper and mount and tighten screws **4**.

Guideline

Screw, front brake caliper	M8	25 Nm (18.4 lbf ft)	Loctite® 243™
----------------------------	----	---------------------	----------------------

- Position the brake line. Put the clamp on and mount and tighten screws **5**.

Finishing work

- Install the front wheel. (p. 65)

11.9 Removing the fork protector

Preparatory work

- Raise the motorcycle with the lift stand. (p. 33)
- Remove the front wheel. (p. 65)
- Remove the fork legs. (p. 34)

Main work

- Remove screws **1** on the left fork leg. Lift off the fork protector.
- Remove the screws on the right fork leg. Lift off the fork protector.

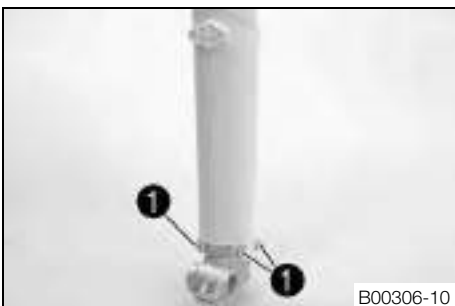

B00306-10

11.10 Installing the fork protector

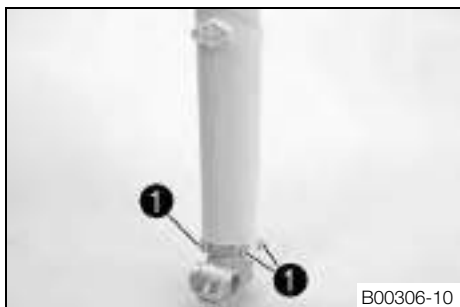

Main work

- Position the fork protection on the left fork leg. Mount and tighten screws ①.

Guideline

Remaining screws, chassis	M6	10 Nm (7.4 lbf ft)
---------------------------	----	--------------------

- Position the fork protection on the right fork leg. Mount and tighten the screws.

Guideline

Remaining screws, chassis	M6	10 Nm (7.4 lbf ft)
---------------------------	----	--------------------

Finishing work

- Install the fork legs. (p. 35)
- Install the front wheel. (p. 65)

11.11 Removing the lower triple clamp

Preparatory work

- Raise the motorcycle with the lift stand. (p. 33)
- Remove the front wheel. (p. 65)
- Remove the fork legs. (p. 34)
- Remove the start number plate. (p. 39)
- Remove the front fender. (p. 40)

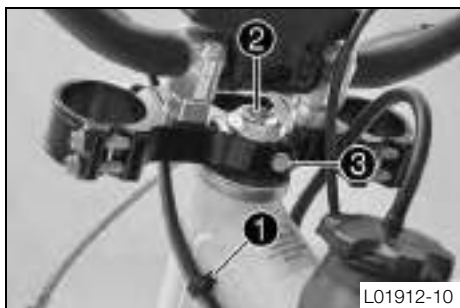

Main work

- Take off cable holder ① in front of the left radiator.
- Remove screw ②.
- Remove screw ③.
- Take off the upper triple clamp with the handlebar and set it aside.

Info

Protect the components against damage by covering them. Do not bend the cables and lines.



- Remove O-ring ④. Remove protective ring ⑤.
- Take out the lower triple clamp with the steering stem.
- Take out the upper steering head bearing.

11.12 Installing the lower triple clamp

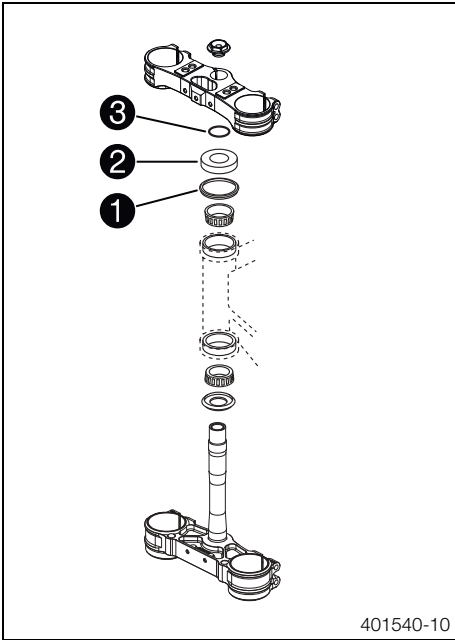

Main work

- Clean the bearing and sealing elements, check for damage, and grease.

High viscosity grease (☛ p. 102)

- Insert the lower triple clamp with the steering stem. Mount the upper steering head bearing.
- Check whether the top steering head seal **1** is correctly positioned.
- Slide on protective ring **2** and O-ring **3**.



- Position the upper triple clamp with the steering.
- Mount screw **4** but do not tighten yet.

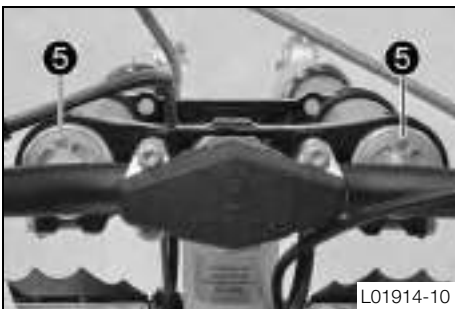

- Position the fork legs.
- ✓ Bleeder screws **5** face toward the front.

Info

Grooves are milled into the side of the upper end of the fork legs. The second milled groove (from the top) must be flush with the top edge of the upper triple clamp.

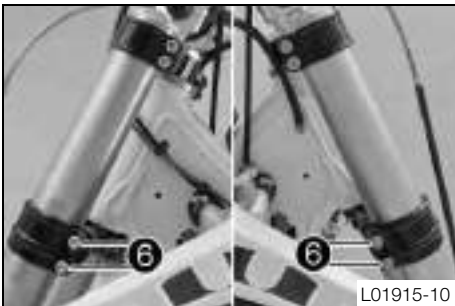

- Tighten screws **6**.

Guideline

Screw, bottom triple clamp	M8	12 Nm (8.9 lbf ft)
----------------------------	----	--------------------



- Tighten screw **4**.

Guideline

Screw, top steering head	M20x1.5	12 Nm (8.9 lbf ft)
--------------------------	---------	--------------------

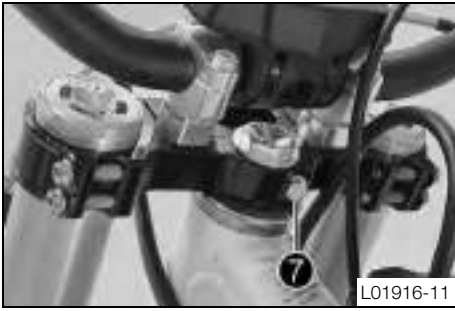

- Mount and tighten screw **7**.

Guideline

Screw, top steering stem	M8	17 Nm (12.5 lbf ft)	Loctite® 243™
--------------------------	----	------------------------	----------------------

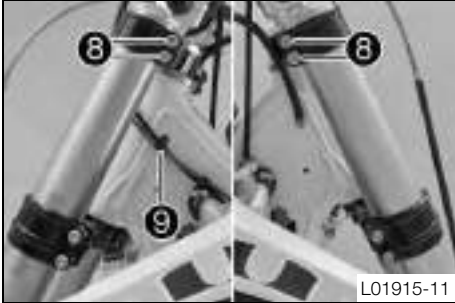

- Tighten screws **8**.

Guideline

Screw, top triple clamp	M8	17 Nm (12.5 lbf ft)	
-------------------------	----	---------------------	--

- Secure the wiring harness with cable holder **9**.

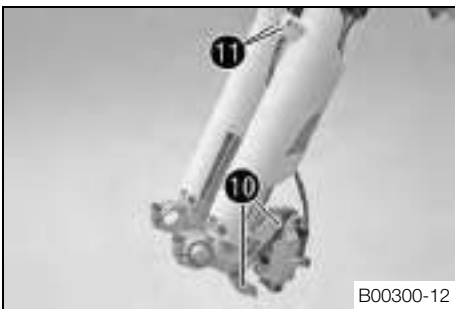

- Position the brake caliper. Mount and tighten screws **10**.

Guideline

Screw, front brake caliper	M8	25 Nm (18.4 lbf ft)	Loctite® 243™
----------------------------	----	------------------------	----------------------

- Position the brake line and clamp. Mount and tighten screws **11**.

Finishing work

- Install the front fender. (☞ p. 40)
- Install the start number plate. (☞ p. 40)
- Install the front wheel. ☞ (☞ p. 65)
- Check that the wiring harness, throttle cables and brake and clutch lines can move freely and are routed correctly.
- Check the play of the steering head bearing. (☞ p. 38)
- Remove the motorcycle from the lift stand. (☞ p. 33)

11.13 Checking the play of the steering head bearing



Warning

Danger of accidents Unstable vehicle handling from incorrect steering head bearing play.

- Adjust the steering head bearing play without delay. (Your authorized Husqvarna workshop will be glad to help.)



Info

If the bike is ridden with play in the steering head bearing, the bearing and the bearing seats in the frame can become damaged over time.

Preparatory work

- Raise the motorcycle with the lift stand. (☞ p. 33)

Main work

- Move the handlebar to the straight-ahead position. Move the fork legs to and fro in the direction of travel.

No play should be noticeable in the steering head bearing.

- » If there is noticeable play present:
 - Adjust the play of the steering head bearing. ☞ (☞ p. 39)

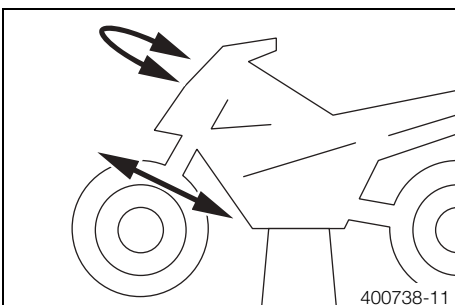

- Move the handlebar to and fro over the entire steering range.

The handlebar must be able to move easily over the entire steering range. There should be no perceptible detent positions.

- » If detent positions are noticeable:
 - Adjust the play of the steering head bearing. (☞ p. 39)
 - Check the steering head bearing and replace if required.

Finishing work

- Remove the motorcycle from the lift stand. (☞ p. 33)

11.14 Adjusting the play of the steering head bearing ☞

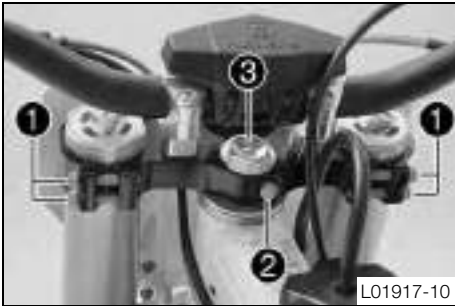

L01917-10

Preparatory work

- Raise the motorcycle with the lift stand. (☞ p. 33)
- Remove the handlebar cushion.

Main work

- Loosen screws ①. Remove screw ②.
- Loosen and retighten screw ③.

Guideline

Screw, top steering head	M20x1.5	12 Nm (8.9 lbf ft)
--------------------------	---------	--------------------

- Using a plastic hammer, tap lightly on the upper triple clamp to avoid strains.
- Tighten screws ①.

Guideline

Screw, top triple clamp	M8	17 Nm (12.5 lbf ft)
-------------------------	----	---------------------

- Mount and tighten screw ②.

Guideline

Screw, top steering stem	M8	17 Nm (12.5 lbf ft)	Loctite® 243™
--------------------------	----	---------------------	----------------------

Finishing work

- Check the play of the steering head bearing. (☞ p. 38)
- Remove the motorcycle from the lift stand. (☞ p. 33)
- Mount the handlebar cushion.

11.15 Greasing the steering head bearing ☞

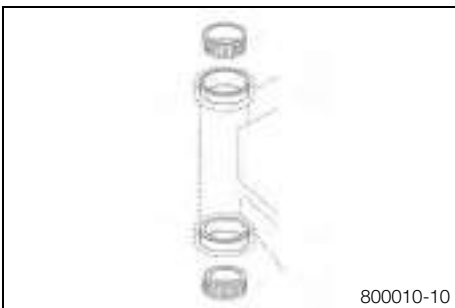

800010-10

- Remove the lower triple clamp. ☞ (☞ p. 36)
- Install the lower triple clamp. ☞ (☞ p. 37)

11.16 Removing the start number plate

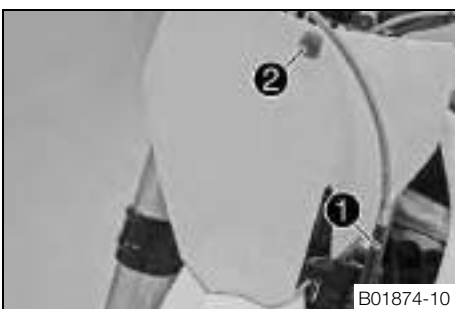

B01874-10

- Take brake line ① out of the brake line guide.
- Remove screw ②. Take off the start number plate.

11.17 Installing the start number plate

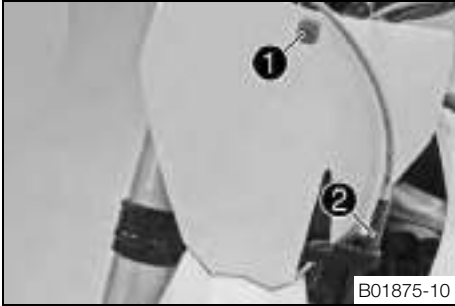

B01875-10

- Position the start number plate. Mount and tighten screw ❶.

Guideline

Remaining screws, chassis	M6	10 Nm (7.4 lbf ft)
---------------------------	----	--------------------

- ✓ The holding lugs engage.

- Position brake line ❷ in the brake line guide.

11.18 Removing the front fender

Preparatory work

- Remove the start number plate. (☛ p. 39)

Main work

- Remove screws ❶ and ❷. Remove the front fender.

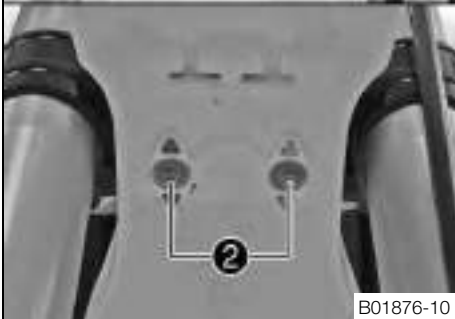
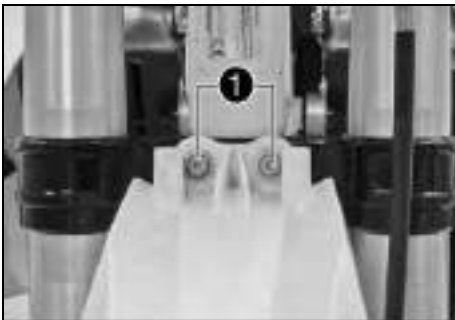

B01876-10

11.19 Installing the front fender

Main work

- Position the front fender. Mount and tighten screws ❶ and ❷.

Guideline

Remaining screws, chassis	M6	10 Nm (7.4 lbf ft)
---------------------------	----	--------------------

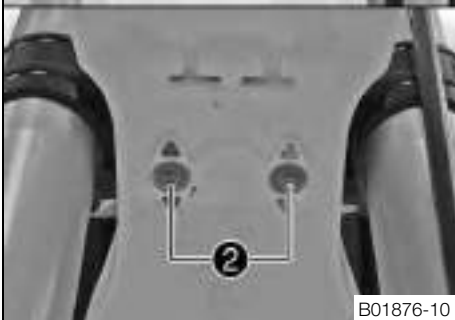
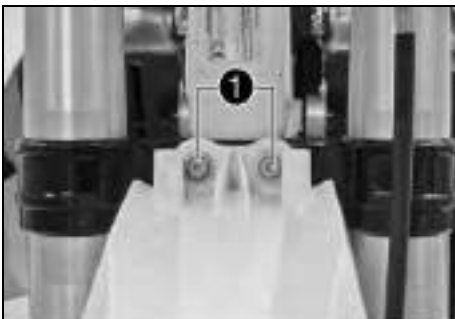

B01876-10

Finishing work

- Install the start number plate. (☛ p. 40)

11.20 Removing the shock absorber

Preparatory work

- Raise the motorcycle with the lift stand. (☛ p. 33)
- Remove the right side cover. (☛ p. 45)
- Remove the main silencer. (☛ p. 44)

Main work

- Remove screw ❶.
- Remove screw cap ❷.

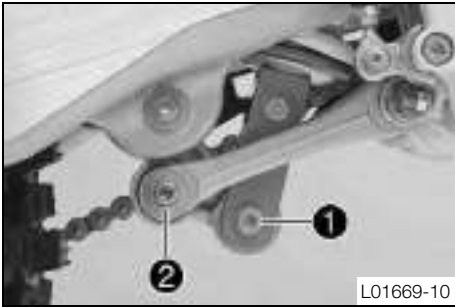

L01669-10

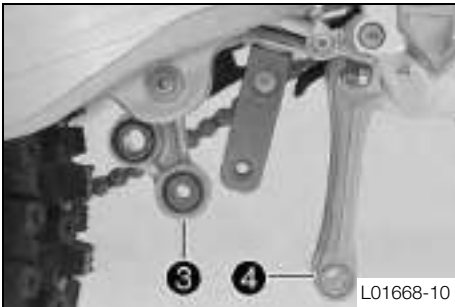

L01668-10

- Press angle lever ❸ toward the rear.
- Press linkage lever ❹ downward.



L01664-11

- Remove screw ❺.
- Remove the shock absorber from the top.

11.21 Installing the shock absorber

Main work

- Insert the shock absorber from above.
- Position the shock absorber.
- Mount and tighten screw ❶.

Guideline

Screw, top shock absorber	M10	60 Nm (44.3 lbf ft)	Loctite® 2701™
---------------------------	-----	------------------------	-----------------------



L01664-10

- Position the angle lever and linkage lever.
- Mount and tighten screw cap ❷.

Guideline

Nut, linkage lever to angle lever	M14x1.5	80 Nm (59 lbf ft)
-----------------------------------	---------	-------------------

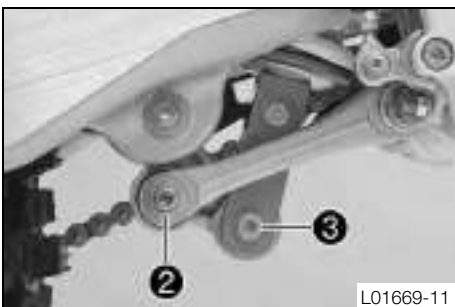

L01669-11

- Mount and tighten screw ❸.

Guideline

Screw, bottom shock absorber	M10	60 Nm (44.3 lbf ft)	Loctite® 2701™
------------------------------	-----	------------------------	-----------------------

Finishing work

- Install the main silencer. (☛ p. 44)
- Install the right side cover. (☛ p. 45)
- Remove the motorcycle from the lift stand. (☛ p. 33)

11.22 Removing the seat

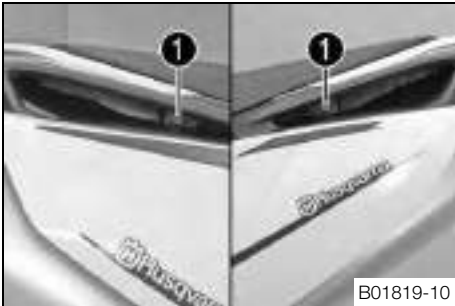

- Remove screws 1 in the recessed grips on the left and right.
- Raise the rear of the seat, push the seat back, and lift it off.

11.23 Mounting the seat



- Hook in the front of the seat at the collar bushing of the fuel tank, lower at the rear and simultaneously push forward.
- Make sure that the seat is correctly locked in.
- Mount and tighten the screws for securing the seat.

Guideline

Remaining screws, chassis	M6	10 Nm (7.4 lbf ft)
---------------------------	----	--------------------

11.24 Removing the air filter box lid



- Release catch 1, pull off the air filter box lid sideways in areas A and B, and remove toward the rear.

11.25 Installing the air filter box lid



- Position the air filter box lid and catch 1. Engage the air filter box lid in areas A and B.
- Engage catch 1.

11.26 Removing the air filter

Note

Engine failure Unfiltered intake air has a negative effect on the service life of the engine.

- Never operate the vehicle without an air filter as dust and dirt will enter the engine and lead to increased wear.



Warning

Environmental hazard Hazardous substances cause environmental damage.

- Oil, grease, filters, fuel, cleaners, brake fluid, etc., should be disposed of as stipulated in applicable regulations.

Preparatory work

- Remove the air filter box lid. (p. 42)

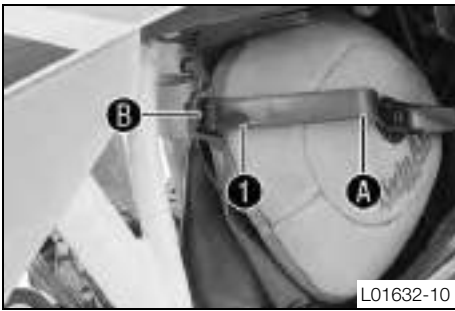

L01632-10

Main work

- Push air filter holder **1** toward the air filter at position **A** and detach it at end **B**. Swing the air filter holder to one side and remove the air filter with the air filter support.
- Remove the air filter from the air filter support.

11.27 Cleaning the air filter and air filter box



Warning

Environmental hazard Hazardous substances cause environmental damage.

- Oil, grease, filters, fuel, cleaners, brake fluid, etc., should be disposed of as stipulated in applicable regulations.



Info

Do not clean the air filter with fuel or petroleum since these substances attack the foam.



L00944-10

Preparatory work

- Remove the air filter box lid. (☞ p. 42)
- Remove the air filter. (☞ p. 42)

Main work

- Wash the air filter thoroughly in special cleaning liquid and allow it to dry properly.



Info

Only squeeze the air filter to dry it; never wring it out.

- Oil the dry air filter with a high quality filter oil.
- Clean the air filter box.
- Clean the intake flange and check it for damage and tightness.

Finishing work

- Install the air filter. (☞ p. 43)
- Install the air filter box lid. (☞ p. 42)

11.28 Installing the air filter

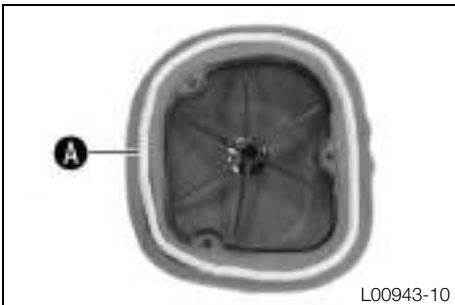

L00943-10

Main work

- Mount the clean air filter on the air filter support.
- Grease the air filter in area **A**.

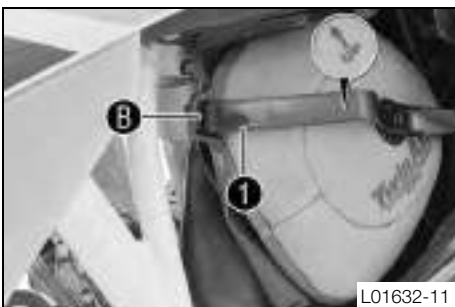

L01632-11

- Insert both parts together, position them, and fasten them using air filter holder **1** in area **B**.

✓ The arrow of marking **UP** faces up.



Info

If the air filter is not correctly mounted, dust and dirt can enter the engine and cause damage.

Finishing work

- Install the air filter box lid. (☞ p. 42)

11.29 Sealing the air filter box

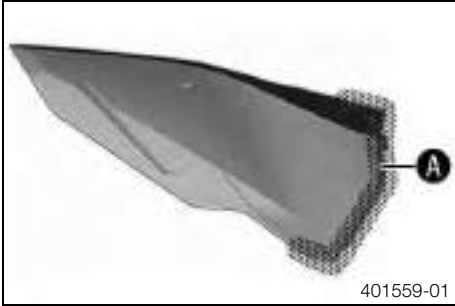

- Seal the air filter box in the marked area **A**.

11.30 Removing the main silencer



Warning

Danger of burns The exhaust system gets very hot when the vehicle is driven.

- Allow the exhaust system to cool down. Do not touch hot components.

Preparatory work

- Remove the right side cover. ( p. 45)

Main work

- Remove screws **1**.
- Pull the main silencer off of the manifold at the rubber sleeve **2**.

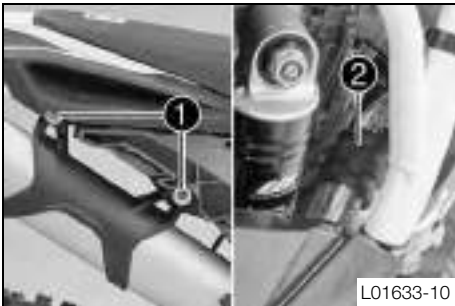

11.31 Installing the main silencer



Main work

- Mount the main silencer with rubber sleeve **1**.
- Mount and tighten screws **2**.

Guideline

Remaining screws, chassis	M6	10 Nm (7.4 lbf ft)
---------------------------	----	--------------------

Finishing work

- Install the right side cover. ( p. 45)

11.32 Changing the glass fiber yarn filling of the main silencer



Warning

Danger of burns The exhaust system gets very hot when the vehicle is driven.



- Allow the exhaust system to cool down. Do not touch hot components.



Info

Over time, the fibers of the glass fiber yarn escape and the damper "burns" out. Not only is the noise level higher, the performance characteristic changes.

Preparatory work

- Remove the right side cover. ( p. 45)
- Remove the main silencer. ( p. 44)

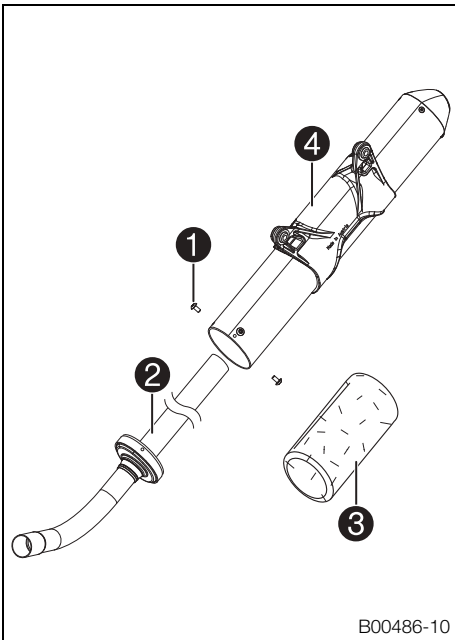

Main work

- Remove screws ①. Pull out inner tube ②.
- Pull the glass fiber yarn filling ③ from the inner tube.
- Clean the parts that are to be reinstalled.
- Mount the new glass fiber yarn filling ③ on the inner tube.
- Slide outer tube ④ over the inner tube with the new glass fiber yarn filling.
- Mount and tighten all screws ①.

Finishing work

- Install the main silencer. (☛ p. 44)
- Install the right side cover. (☛ p. 45)

11.33 Removing the right side cover



- Remove screw ①.
- Pull off the side cover in area A sideways and remove it toward the rear.

11.34 Installing the right side cover



- Position the side cover and engage in area A.
- Mount and tighten screw ①.

Guideline

Remaining screws, chassis	M6	10 Nm (7.4 lbf ft)
---------------------------	----	--------------------

11.35 Removing the fuel tank ☛



Danger

Fire hazard Fuel is highly flammable.

- Never refuel the vehicle near open flames or burning cigarettes, and always switch off the engine first. Be careful that no fuel is spilt, especially on hot vehicle components. Clean up spilt fuel immediately.
- The fuel in the fuel tank expands when warm and may emerge if overfilled. Follow the instructions on refueling.

Warning

Danger of poisoning Fuel is poisonous and a health hazard.

- Fuel must not come into contact with the skin, eyes, or clothing. Do not breathe in the fuel vapors. If contact occurs with the eyes, rinse with water immediately and contact a physician. Immediately clean contaminated areas on the skin with soap and water. If fuel is swallowed, contact a physician immediately. Change clothing that is contaminated with fuel. Store fuel properly in a suitable canister and keep away from children.

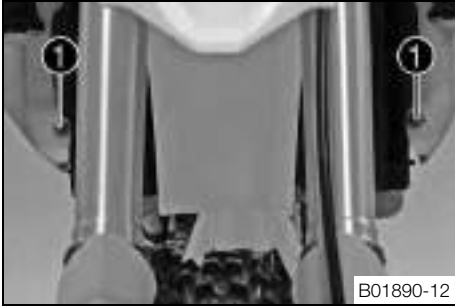

B01890-12

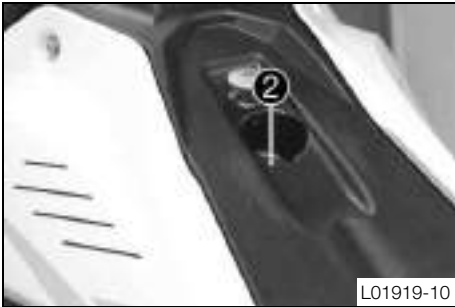

L01919-10



B01810-01

Preparatory work

- Remove the seat. (☞ p. 42)

Main work

- Turn handle ❶ of the fuel tap to the **OFF** position. (Figure L01808-10☞ p. 13)
- Pull off the fuel hose.

i Info

Remaining fuel may run out of the fuel hose.

- Remove screws ❶ with the collar bushings.
- Remove screw ❷ with the rubber bushing.
- Remove the tube from the fuel tank vent line.
- Pull both spoilers off of the sides of the radiator bracket and lift off the fuel tank.

11.36 Installing the fuel tank ☞

Danger

Fire hazard Fuel is highly flammable.

- Never refuel the vehicle near open flames or burning cigarettes, and always switch off the engine first. Be careful that no fuel is spilt, especially on hot vehicle components. Clean up spilt fuel immediately.
- The fuel in the fuel tank expands when warm and may emerge if overfilled. Follow the instructions on refueling.

Warning

Danger of poisoning Fuel is poisonous and a health hazard.

- Fuel must not come into contact with the skin, eyes, or clothing. Do not breathe in the fuel vapors. If contact occurs with the eyes, rinse with water immediately and contact a physician. Immediately clean contaminated areas on the skin with soap and water. If fuel is swallowed, contact a physician immediately. Change clothing that is contaminated with fuel.

Preparatory work

- Remove the seat. (☞ p. 42)
- Remove the fuel tank. ☞ (☞ p. 45)
- Check the routing of the throttle cable. (☞ p. 51)



Main work

- Position the fuel tank and fit the two spoilers to the sides of the radiator bracket.
- Make sure that no cables are trapped or damaged.

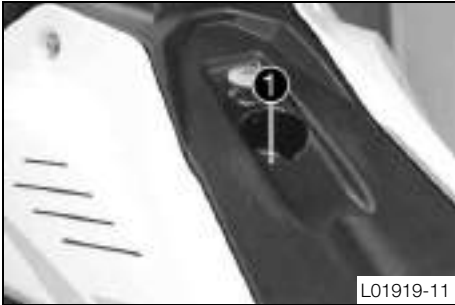

- Mount the fuel tank vent hose.
- Mount and tighten screw ① with the rubber bushing.

Guideline

Remaining screws, chassis	M6	10 Nm (7.4 lbf ft)
---------------------------	----	--------------------

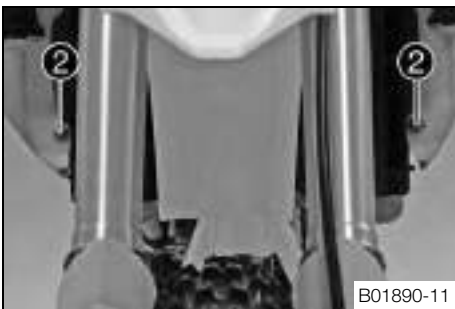

- Mount and tighten screws ② with the collar bushings.

Guideline

Remaining screws, chassis	M6	10 Nm (7.4 lbf ft)
---------------------------	----	--------------------

- Connect the fuel hose.

Finishing work

- Mount the seat. (☛ p. 42)

11.37 Checking the chain for dirt

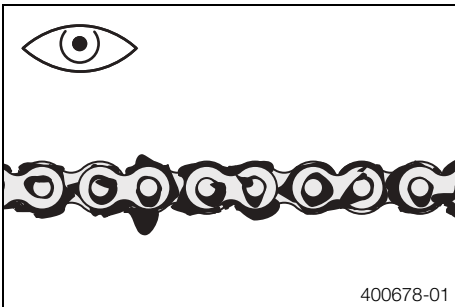

- Check the chain for heavy soiling.
 - » If the chain is very dirty:
 - Clean the chain. (☛ p. 47)

11.38 Cleaning the chain

Warning
Danger of accidents Oil or grease on the tires reduces their grip.

- Remove oil and grease with a suitable cleaning material.

Warning
Danger of accidents Reduced braking efficiency due to oil or grease on the brake discs.

- Always keep the brake discs free of oil and grease, and clean them with brake cleaner when necessary.

Warning
Environmental hazard Hazardous substances cause environmental damage.

- Oil, grease, filters, fuel, cleaners, brake fluid, etc., should be disposed of as stipulated in applicable regulations.

Info
 The service life of the chain depends largely on its maintenance.

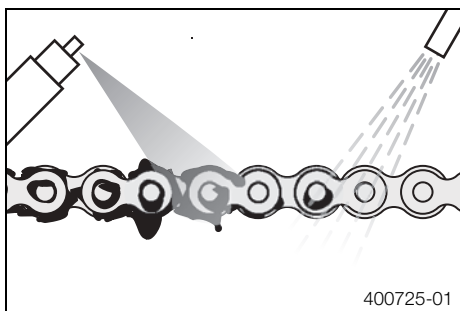

- Clean the chain regularly and then treat with chain spray.

11.39 Checking the chain tension

- Warning**
Danger of accidents Danger caused by incorrect chain tension.
- If the chain is too taut, the components of the secondary power transmission (chain, engine sprocket, rear sprocket, bearings in the transmission and in the rear wheel) will be under additional load. In addition to premature wear, this can cause the chain or the countershaft of the transmission to break in extreme cases. If the chain is too loose, however, it may fall off the engine sprocket or rear sprocket and block the rear wheel or damage the engine. Ensure that the chain tension is correct and adjust it if necessary.



Preparatory work

- Raise the motorcycle with the lift stand. (☛ p. 33)

Main work

- Push the chain at the end of the chain sliding component upwards to measure chain tension **A**.

i **Info**

The bottom chain section **1** must be taut. Chain wear is not always even; repeat this measurement at different chain positions.

Chain tension	55... 58 mm (2.17... 2.28 in)
---------------	-------------------------------

- » If the chain tension does not meet specifications:
 - Adjust the chain tension. (☛ p. 48)

Finishing work

- Remove the motorcycle from the lift stand. (☛ p. 33)

11.40 Adjusting the chain tension

- Warning**
Danger of accidents Danger caused by incorrect chain tension.
- If the chain is too taut, the components of the secondary power transmission (chain, engine sprocket, rear sprocket, bearings in the transmission and in the rear wheel) will be under additional load. In addition to premature wear, this can cause the chain or the countershaft of the transmission to break in extreme cases. If the chain is too loose, however, it may fall off the engine sprocket or rear sprocket and block the rear wheel or damage the engine. Ensure that the chain tension is correct and adjust it if necessary.

Preparatory work

- Raise the motorcycle with the lift stand. (☛ p. 33)
- Check the chain tension. (☛ p. 48)

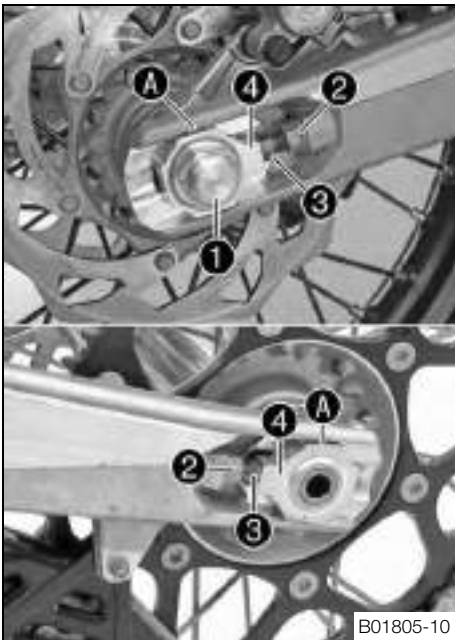

Main work

- Loosen nut ①.
- Loosen nuts ②.
- Adjust the chain tension by turning adjusting screws ③ to the left and right.

Guideline

Chain tension	55... 58 mm (2.17... 2.28 in)	
Turn adjusting screws ③ on the left and right so that the markings on the left and right chain adjusters are in the same position relative to reference marks A. The rear wheel is then correctly aligned.		

- Tighten nuts ②.
- Make sure that chain adjusters ④ are fitted correctly on adjusting screws ③.
- Tighten nut ①.

Guideline

Nut, rear wheel spindle	M20x1.5	80 Nm (59 lbf ft)
-------------------------	---------	-------------------

i Info

The wide adjustment range of the chain adjusters (32 mm) enables different secondary ratios with the same chain length. Chain adjusters ④ can be turned by 180°.

Finishing work

- Remove the motorcycle from the lift stand. (☛ p. 33)

11.41 Checking the chain, rear sprocket, engine sprocket and chain guide

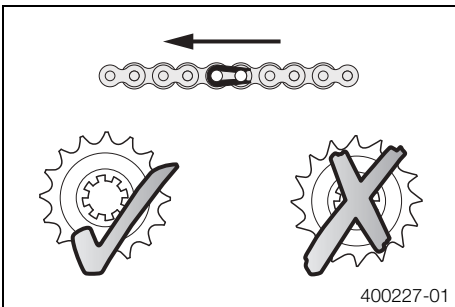

400227-01

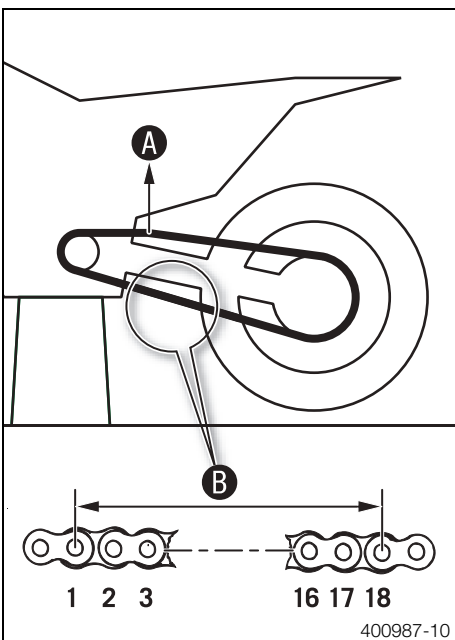

400987-10

Preparatory work

- Raise the motorcycle with the lift stand. (☛ p. 33)

Main work

- Shift gear to neutral.
- Check the rear sprocket and engine sprocket for wear.
 - » If the rear sprocket or engine sprocket is worn:
 - Change the drivetrain kit. ☛

i Info

The engine sprocket, rear sprocket and chain should always be changed together.

- Pull on the upper part of the chain with the specified weight A.

Guideline

Weight, chain wear measurement	10... 15 kg (22... 33 lb.)
--------------------------------	----------------------------

- Measure the distance B of 18 chain links in the lower chain section.

i Info

Chain wear is not always even, so you should repeat this measurement at different chain positions.

Maximum distance B at the longest chain section	272 mm (10.71 in)
-------------------------------------------------	-------------------

- » If the distance B is greater than the specified measurement:

- Change the drivetrain kit. ☛

i Info

When you mount a new chain, you should also change the rear sprocket and engine sprocket. New chains wear out faster on old, worn sprockets.

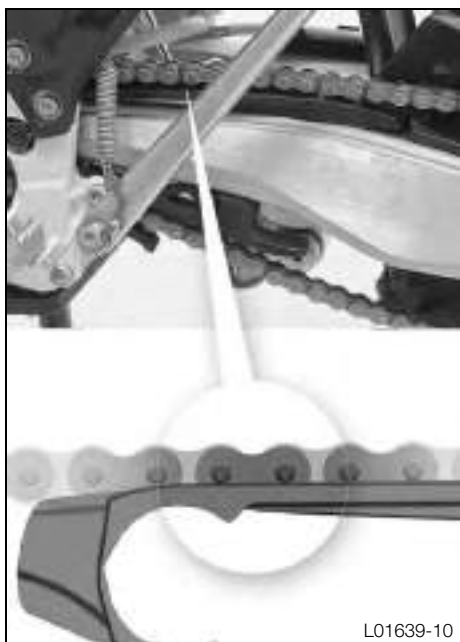

- Check the chain sliding guard for wear.
 - » If the lower bolt edge of the chain is in line with or below the chain sliding guard:
 - Change the chain sliding guard. 🛠️
- Check the chain sliding guard for tightness.
 - » If the chain sliding guard is loose:
 - Tighten the chain sliding guard.

Guideline

Screw, chain sliding guard	M6	6 Nm (4.4 lbf ft)	Loctite® 243™
----------------------------	----	----------------------	----------------------



- Check the chain sliding piece for wear.
 - » If the lower bolt edge of the chain is in line with or below the chain sliding piece:
 - Change the chain sliding piece. 🛠️
- Check the chain sliding piece for tightness.
 - » If the chain sliding piece is loose:
 - Tighten the chain sliding piece.

Guideline

Screw, chain sliding piece	M8	15 Nm (11.1 lbf ft)
----------------------------	----	------------------------

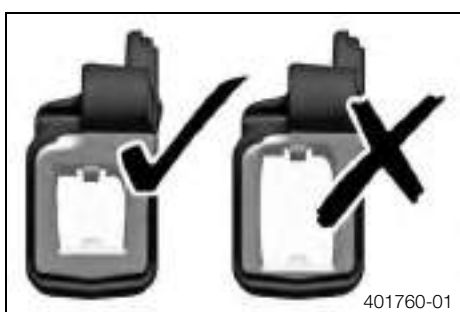

- Check the chain guide for wear.

i Info

Wear can be seen on the front of the chain guide.

- » If the light part of the chain guide is worn:
 - Change the chain guide. 🛠️



- Check the chain guide for tightness.
 - » If the chain guide is loose:
 - Tighten the chain guide.

Guideline

Remaining screws, chassis	M6	10 Nm (7.4 lbf ft)
Remaining nuts, chassis	M6	10 Nm (7.4 lbf ft)

Finishing work

- Remove the motorcycle from the lift stand. (🛠️ p. 33)

11.42 Checking the frame



- Check the frame for cracking and deformation.
 - » If the frame exhibits cracking or deformation due to a mechanical impact:
 - Change the frame.



Info

A frame that has been damaged due to a mechanical impact must always be changed. Repair of the frame is not authorized by Husqvarna.

11.43 Checking the swingarm



- Check the swingarm for damage, cracking, and deformation.
 - » If the swingarm shows signs of damage, cracking, or deformation:
 - Change the swingarm.



Info

A damaged swingarm must always be changed. Repair of the swingarm is not authorized by Husqvarna.

11.44 Checking the routing of the throttle cable

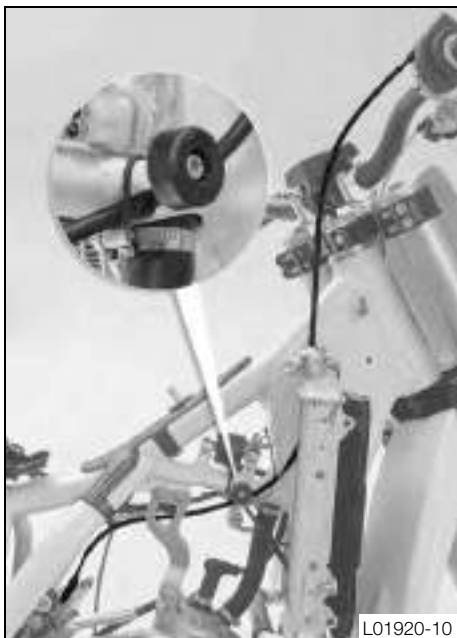

Preparatory work

- Remove the seat. (☞ p. 42)
- Remove the fuel tank. (☞ p. 45)

Main work (125 TC EU)

- Check the routing of the throttle cable.

The throttle cable must be routed along the back of the handlebar, to the right of the frame, below the fuel tank bracket, and to the carburetor.

- » If the throttle cable is not routed as specified:
 - Correct the routing of the throttle cable.



(250 TC EU)

- Check the routing of the throttle cable.

The throttle cable must be routed along the back of the handlebar, to the right of the frame, below the fuel tank bracket, and to the carburetor.

- » If the throttle cable is not routed as specified:
 - Correct the routing of the throttle cable.

Finishing work

- Install the fuel tank. (☛ p. 46)
- Mount the seat. (☛ p. 42)

11.45 Checking the rubber grip

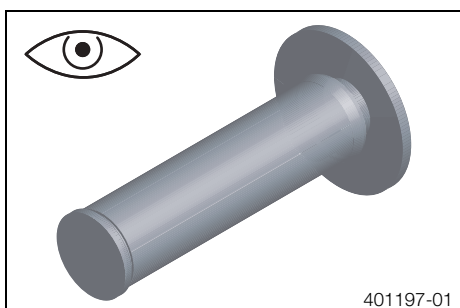

- Check the rubber grips on the handlebar for damage and wear and to ensure they are firmly seated.
 - » If a rubber grip is damaged, worn, or loose:
 - Change and secure the rubber grip.

Rubber grip adhesive (00062030051) (☛ p. 102)

11.46 Additionally securing the rubber grip



Preparatory work

- Check the rubber grip. (☛ p. 52)

Main work

- Secure the rubber grip at two points using the securing wire.

Securing wire (54812016000)

Wire twister forceps (U6907854)

- ✓ The twisted wire ends face away from the hands and are bent toward the rubber grip.

11.47 Adjusting the basic position of the clutch lever



(125 TC EU)

- Adjust the basic setting of the clutch lever to your hand size by turning adjusting screw ①.

i Info
 When the adjusting screw is turned counterclockwise, the clutch lever moves away from the handlebar.
 When the adjusting screw is turned clockwise, the clutch lever moves closer to the handlebar.
 The range of adjustment is limited.
 Turn the adjusting screw by hand only, and do not apply any force.
 Do not make any adjustments while riding!



(250 TC EU)

- Adjust the basic setting of the clutch lever to your hand size by turning adjusting screw ①.

i Info
 When the adjusting screw is turned counterclockwise, the clutch lever moves closer to the handlebar.
 When the adjusting screw is turned clockwise, the clutch lever moves away from the handlebar.
 The range of adjustment is limited.
 Turn the adjusting screw by hand only, and do not apply any force.
 Do not make any adjustments while riding!

11.48 Checking/correcting the fluid level of the hydraulic clutch

i Info
 The fluid level rises with increasing wear of the clutch lining discs.

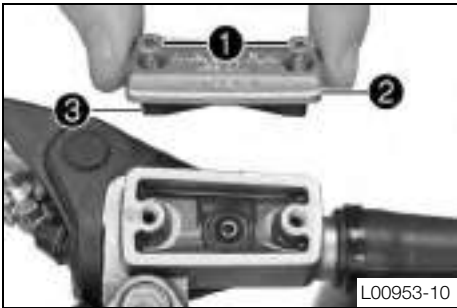

(125 TC EU)

- Move the clutch fluid reservoir mounted on the handlebar to a horizontal position.
- Remove screws ①.
- Remove cover ② with membrane ③.
- Check the fluid level.

Fluid level under top edge of container	4 mm (0.16 in)
-----------------------------------------	----------------

» If the level of the fluid does not meet specifications:

- Correct the fluid level of the hydraulic clutch.

Hydraulic oil (15) (☛ p. 100)

- Position the cover with the membrane. Mount and tighten the screws.

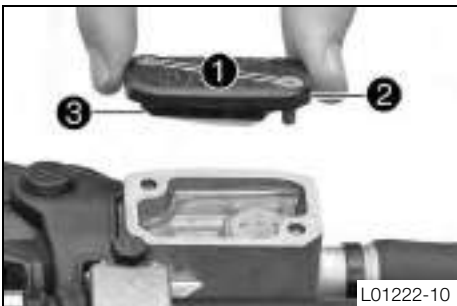

(250 TC EU)

- Move the clutch fluid reservoir mounted on the handlebar to a horizontal position.
- Remove screws ①.
- Remove cover ② with membrane ③.
- Check the fluid level.

Fluid level under top edge of container	4 mm (0.16 in)
-----------------------------------------	----------------

» If the level of the fluid does not meet specifications:

- Correct the fluid level of the hydraulic clutch.

Brake fluid DOT 4 / DOT 5.1 (☛ p. 100)

- Position the cover with the membrane. Mount and tighten the screws.

i Info
 Wash off overflowed or spilled brake fluid immediately with water.

11.49 Changing the hydraulic clutch fluid



Warning

Environmental hazard Hazardous substances cause environmental damage.

- Oil, grease, filters, fuel, cleaners, brake fluid, etc., should be disposed of as stipulated in applicable regulations.

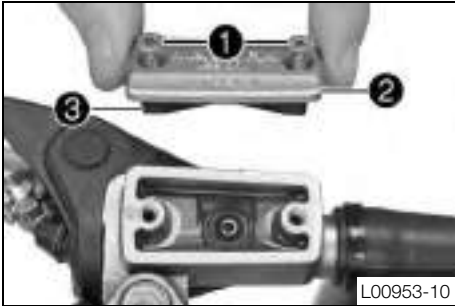

L00953-10

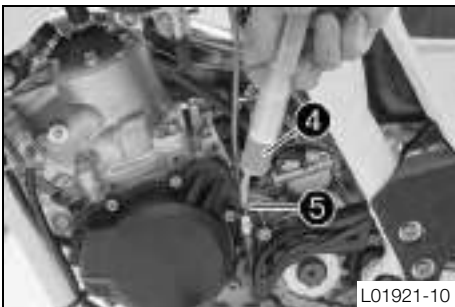

L01921-10



L00953-11

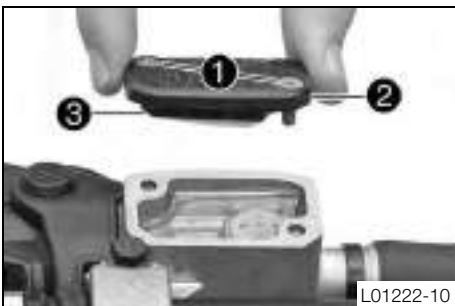

L01222-10

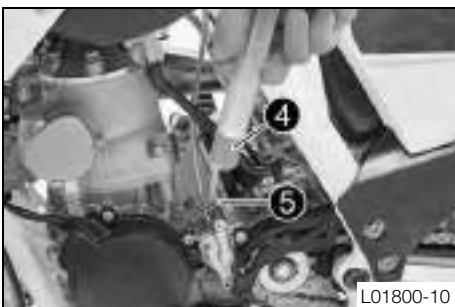

L01800-10

(125 TC EU)

- Move the clutch fluid reservoir mounted on the handlebar to a horizontal position.
- Remove screws **1**.
- Remove cover **2** with membrane **3**.

- Fill bleeding syringe **4** with the appropriate hydraulic fluid.

Bleed syringe (50329050000)

Hydraulic oil (15) ( p. 100)

- On the slave cylinder of the clutch, remove bleeder screw **5** and mount bleeding syringe **4**.

- Inject the liquid into the system until it escapes from bore hole **6** of the master cylinder without bubbles.

- To prevent overflow, drain fluid occasionally from the master cylinder reservoir.
- Remove the bleeding syringe. Mount and tighten the bleeder screw.
- Correct the fluid level of the hydraulic clutch.

Guideline

Fluid level under top level of container	4 mm (0.16 in)
------------------------------------------	----------------

- Position the cover with the membrane. Mount and tighten the screws.

(250 TC EU)

- Move the clutch fluid reservoir mounted on the handlebar to a horizontal position.
- Remove screws **1**.
- Remove cover **2** with membrane **3**.

- Fill bleeding syringe **4** with the appropriate hydraulic fluid.

Bleed syringe (50329050000)

Brake fluid DOT 4 / DOT 5.1 ( p. 100)

- On the slave cylinder of the clutch, remove bleeder screw **5** and mount bleeding syringe **4**.

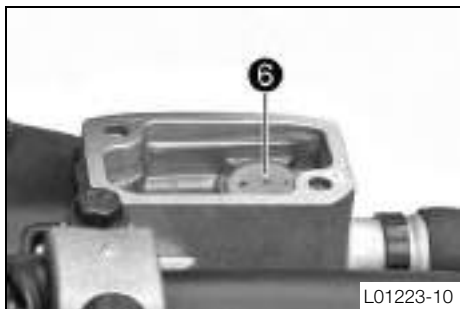

- Inject the liquid into the system until it escapes from bore hole ⑥ of the master cylinder without bubbles.
- To prevent overflow, drain fluid occasionally from the master cylinder reservoir.
- Remove the bleeding syringe. Mount and tighten the bleeder screw.
- Correct the fluid level of the hydraulic clutch.

Guideline

Fluid level under top level of container	4 mm (0.16 in)
------------------------------------------	----------------

- Position the cover with the membrane. Mount and tighten the screws.

12.1 Checking the free travel of the hand brake lever

Warning
Danger of accidents Brake system failure.

- If there is no free travel on the hand brake lever, pressure builds up on the front brake circuit. The front brake can fail due to overheating. Adjust the free travel on hand brake lever according to specifications.



- Push the hand brake lever forward and check free travel **A**.

Free travel of hand brake lever	$\geq 3 \text{ mm } (\geq 0.12 \text{ in})$
---------------------------------	---------------------------------------------

- » If the free travel does not meet specifications:
 - Adjust the basic position of the hand brake lever. (☛ p. 56)

12.2 Adjusting the basic position of the hand brake lever

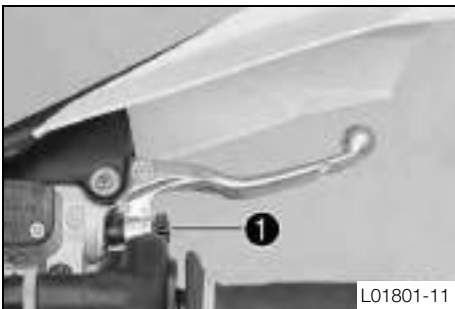

- Check the free travel of the hand brake lever. (☛ p. 56)
- Adjust the basic setting of the hand brake lever to your hand size by turning adjusting screw **1**.

i Info
 When the adjusting screw is turned clockwise, the hand brake lever moves away from the handlebar.
 When the adjusting screw is turned counterclockwise, the hand brake lever moves closer to the handlebar.
 The range of adjustment is limited.
 Turn the adjusting screw by hand only, and do not apply any force.
 Do not make any adjustments while riding!

12.3 Checking the brake discs

Warning
Danger of accidents Reduced braking efficiency due to worn brake disc(s).

- Change the worn brake disc(s) without delay. (Your authorized Husqvarna workshop will be glad to help.)

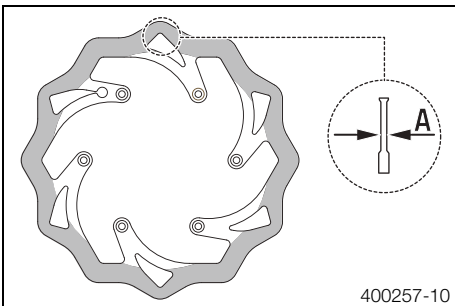

- Check the thickness of the front and rear brake discs at several places on the disc to see if it conforms to measurement **A**.

i Info
 Wear reduces the thickness of the brake disc around the area used by the brake linings.

Brake discs - wear limit	
Front	2.5 mm (0.098 in)
Rear	3.5 mm (0.138 in)

- » If the brake disc thickness is less than the specified value:
 - Change the brake disc.
- Check the front and rear brake discs for damage, cracking and deformation.
 - » If the brake disc exhibits damage, cracking or deformation:
 - Change the brake disc.

12.4 Checking the front brake fluid level

- Warning**
Danger of accidents Failure of the brake system.
- If the brake fluid level falls below the **MIN** mark, this indicates a leakage in the brake system or worn-out brake linings. Check the brake system and do not continue riding. (Your authorized Husqvarna workshop will be glad to help.)

- Warning**
Danger of accidents Reduced braking efficiency due to old brake fluid.
- Change the brake fluid of the front and rear brake according to the service schedule. (Your authorized Husqvarna workshop will be glad to help.)

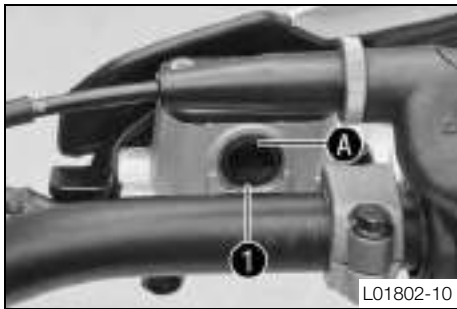

Preparatory work

- Check the front brake linings. (☞ p. 58)

Main work

- Move the brake fluid reservoir mounted on the handlebar to a horizontal position.
- Check the brake fluid level in the viewer ①.
 - » If the brake fluid level is below the A marking:
 - Add front brake fluid. ☞ (☞ p. 57)

12.5 Adding front brake fluid ☞

- Warning**
Danger of accidents Failure of the brake system.
- If the brake fluid level falls below the **MIN** mark, this indicates a leakage in the brake system or worn-out brake linings. Check the brake system and do not continue riding. (Your authorized Husqvarna workshop will be glad to help.)

- Warning**
Skin irritation Brake fluid can cause skin irritation on contact.
- Avoid contact with skin and eyes, and keep out of the reach of children.
 - Wear suitable protective clothing and goggles.
 - If brake fluid comes into contact with the eyes, flush the eyes thoroughly with water and consult a physician immediately.

- Warning**
Danger of accidents Reduced braking efficiency due to old brake fluid.
- Change the brake fluid of the front and rear brake according to the service schedule. (Your authorized Husqvarna workshop will be glad to help.)

- Warning**
Environmental hazard Hazardous substances cause environmental damage.
- Oil, grease, filters, fuel, cleaners, brake fluid, etc., should be disposed of as stipulated in applicable regulations.

- Info**
- Never use DOT 5 brake fluid! It is silicone-based and purple in color. Oil seals and brake lines are not designed for DOT 5 brake fluid.
 Avoid contact between brake fluid and painted parts. Brake fluid attacks paint!
 Use only clean brake fluid from a sealed container!

Preparatory work

- Check the front brake linings. (☞ p. 58)

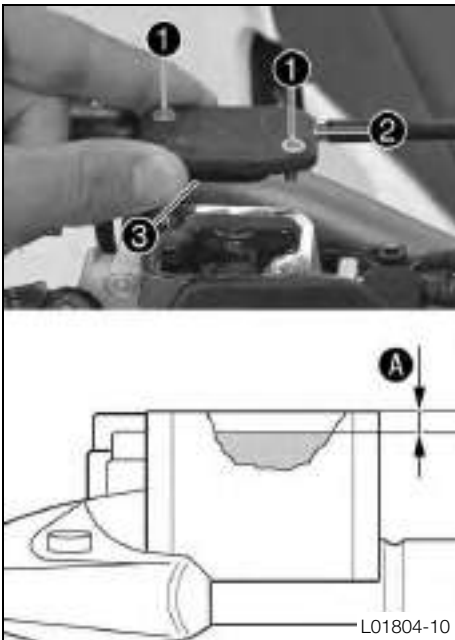

Main work

- Move the brake fluid reservoir mounted on the handlebar to a horizontal position.
- Remove screws ①.
- Remove cover ② with membrane ③.
- Add brake fluid to level A.

Guideline

Dimension A (brake fluid level below top edge of container)	5 mm (0.2 in)
-------------------------------------------------------------	---------------

Brake fluid DOT 4 / DOT 5.1 (☞ p. 100)

- Position the cover with the membrane. Mount and tighten the screws.

Info

Clean up overflowed or spilled brake fluid immediately with water.

12.6 Checking the front brake linings

Warning

Danger of accidents Reduced braking efficiency caused by worn brake linings.

- Change worn brake linings immediately. (Your authorized Husqvarna workshop will be glad to help.)

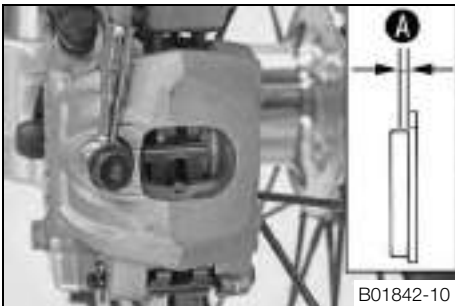

- Check the brake linings for minimum thickness A.

Minimum thickness A	≥ 1 mm (≥ 0.04 in)
---------------------	--------------------

- » If the minimum thickness is less than specified:
 - Change the front brake linings. ☞ (☞ p. 58)
- Check the brake linings for damage and cracking.
 - » If damage or cracking is visible:
 - Change the front brake linings. ☞ (☞ p. 58)

12.7 Changing the front brake linings ☞

Warning

Danger of accident Brake system failure.

- Maintenance work and repairs must be carried out professionally. (Your authorized Husqvarna workshop will be glad to help.)

Warning

Skin irritation Brake fluid can cause skin irritation on contact.

- Avoid contact with skin and eyes, and keep out of the reach of children.
- Wear suitable protective clothing and goggles.
- If brake fluid comes into contact with the eyes, flush the eyes thoroughly with water and consult a physician immediately.

Warning

Danger of accidents Reduced braking efficiency due to old brake fluid.

- Change the brake fluid of the front and rear brake according to the service schedule. (Your authorized Husqvarna workshop will be glad to help.)

Warning

Environmental hazard Hazardous substances cause environmental damage.

- Oil, grease, filters, fuel, cleaners, brake fluid, etc., should be disposed of as stipulated in applicable regulations.

i Info

Never use DOT 5 brake fluid! It is silicone-based and purple in color. Oil seals and brake lines are not designed for DOT 5 brake fluid.

Avoid contact between brake fluid and painted parts. Brake fluid attacks paint!

Use only clean brake fluid from a sealed container!

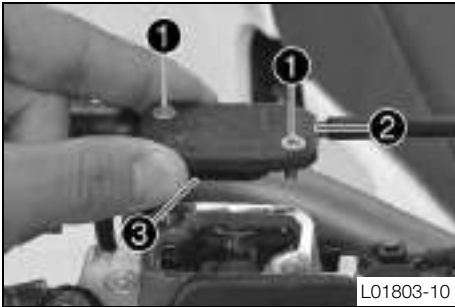

L01803-10

- Move the brake fluid reservoir mounted on the handlebar to a horizontal position.
- Remove screws **1**.
- Remove cover **2** with membrane **3**.

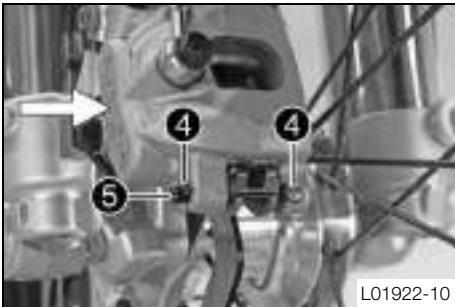

L01922-10

- Manually press the brake caliper to the brake disc to push back the brake pistons. Ensure that brake fluid does not flow out of the brake fluid reservoir, extracting it by suction if it does.

i Info

Make sure when pushing back the brake pistons that you do not press the brake caliper against the spokes.

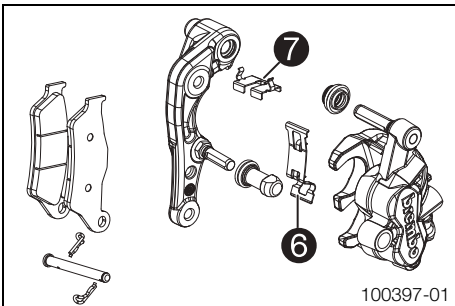

100397-01

- Remove cotter pins **4**, pull out pin **5**, and remove the brake linings.
- Clean the brake caliper and brake caliper support.
- Check that leaf spring **6** in the brake caliper and sliding plate **7** in the brake caliper support are seated correctly.

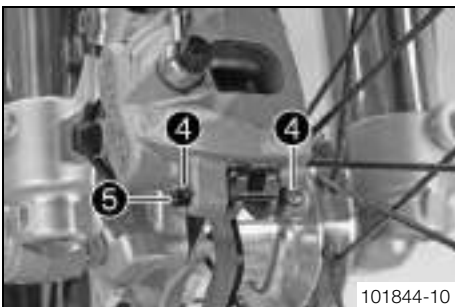

101844-10

- Insert the new brake linings, insert pin **5**, and mount cotter pins **4**.

i Info

Always change the full set of brake linings.

- Operate the hand brake lever several times until the brake linings are lying correctly against the brake disc and there is a pressure point.

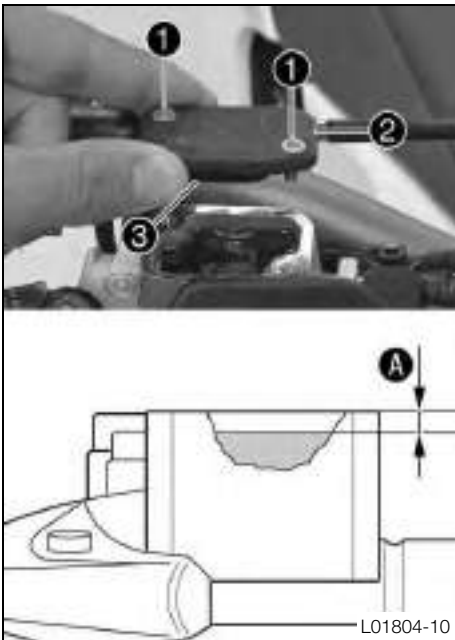

- Correct the brake fluid to level **A**.

Guideline

Dimension A (brake fluid level below top edge of container)	5 mm (0.2 in)
--------------------------------------------------------------------	---------------

Brake fluid DOT 4 / DOT 5.1 (☞ p. 100)

- Position cover **2** with membrane **3**.
- Mount and tighten screws **1**.

i Info
Wash off overflowed or spilled brake fluid immediately with water.

12.8 Checking the free travel of foot brake lever

Warning
Danger of accidents Brake system failure.

- If there is no free travel on the foot brake lever, pressure builds up on the rear brake circuit. The rear brake can fail due to overheating. Adjust the free travel on foot brake lever according to specifications.



- Disconnect spring **1**.
- Move the foot brake lever back and forth between the end stop and the contact to the foot brake cylinder piston and check free travel **A**.

Guideline

Free travel at foot brake lever	3... 5 mm (0.12... 0.2 in)
---------------------------------	----------------------------

- » If the free travel does not meet specifications:
 - Adjust the basic position of the foot brake lever. ☞ (☞ p. 60)
- Reconnect spring **1**.

12.9 Adjusting the basic position of the foot brake lever ☞

Warning
Danger of accidents Brake system failure.

- If there is no free travel on the foot brake lever, pressure builds up on the rear brake circuit. The rear brake can fail due to overheating. Adjust the free travel on foot brake lever according to specifications.

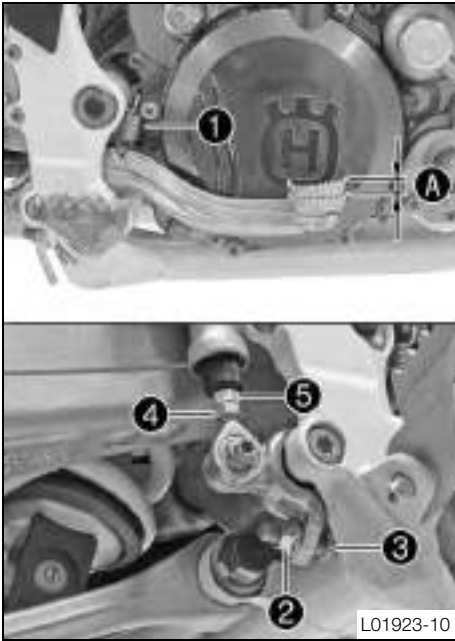

- Disconnect spring ①.
- Loosen nut ④ and, with push rod ⑤, turn it back until you have maximum free travel.
- To adjust the basic position of the foot brake lever individually, loosen nut ② and turn screw ③ accordingly.

i Info
The range of adjustment is limited.

- Turn push rod ⑤ accordingly until you have free travel A. If necessary, adjust the basic position of the foot brake lever.

Guideline

Free travel at foot brake lever	3... 5 mm (0.12... 0.2 in)
---------------------------------	----------------------------

- Hold screw ③ and tighten nut ②.

Guideline

Nut, foot brake lever stop	M8	20 Nm (14.8 lbf ft)
----------------------------	----	---------------------

- Hold push rod ⑤ and tighten nut ④.

Guideline

Remaining nuts, chassis	M6	10 Nm (7.4 lbf ft)
-------------------------	----	--------------------

- Reconnect spring ①.

12.10 Checking the rear brake fluid level

Warning
Danger of accidents Failure of the brake system.

- If the brake fluid level falls below the **MIN** mark, this indicates a leakage in the brake system or worn-out brake linings. Check the brake system and do not continue riding. (Your authorized Husqvarna workshop will be glad to help.)

Warning
Danger of accidents Reduced braking efficiency due to old brake fluid.

- Change the brake fluid of the front and rear brake according to the service schedule. (Your authorized Husqvarna workshop will be glad to help.)

Preparatory work

- Check the rear brake linings. (☞ p. 62)

Main work

- Stand the vehicle upright.
- Check the brake fluid level in the viewer ①.
 - » If the brake fluid level is below the A marking:
 - Add brake fluid for the rear brake. ☞ (☞ p. 61)

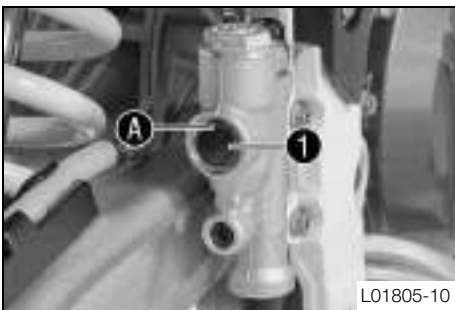

12.11 Adding brake fluid for the rear brake

Warning
Danger of accidents Failure of the brake system.

- If the brake fluid level falls below the **MIN** mark, this indicates a leakage in the brake system or worn-out brake linings. Check the brake system and do not continue riding. (Your authorized Husqvarna workshop will be glad to help.)

Warning
Skin irritation Brake fluid can cause skin irritation on contact.

- Avoid contact with skin and eyes, and keep out of the reach of children.
- Wear suitable protective clothing and goggles.
- If brake fluid comes into contact with the eyes, flush the eyes thoroughly with water and consult a physician immediately.

- Warning**
Danger of accidents Reduced braking efficiency due to old brake fluid.
- Change the brake fluid of the front and rear brake according to the service schedule. (Your authorized Husqvarna workshop will be glad to help.)

- Warning**
Environmental hazard Hazardous substances cause environmental damage.
- Oil, grease, filters, fuel, cleaners, brake fluid, etc., should be disposed of as stipulated in applicable regulations.

i Info
 Never use DOT 5 brake fluid! It is silicone-based and purple in color. Oil seals and brake lines are not designed for DOT 5 brake fluid.
 Avoid contact between brake fluid and painted parts. Brake fluid attacks paint!
 Use only clean brake fluid from a sealed container!

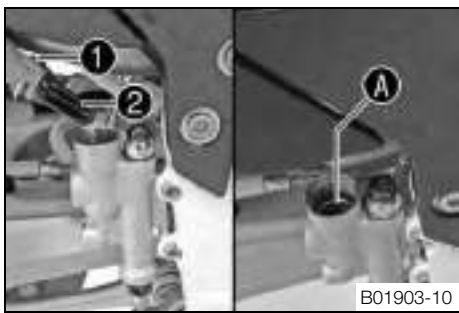

Preparatory work

- Check the rear brake linings. (☞ p. 62)

Main work

- Stand the vehicle upright.
- Remove screw cap ① with membrane ② and the O-ring.
- Add brake fluid to level A.

Brake fluid DOT 4 / DOT 5.1 (☞ p. 100)

- Mount the screw cap with the membrane and the O-ring.

i Info
 Clean up overflowed or spilt brake fluid immediately with water.

12.12 Checking the rear brake linings

- Warning**
Danger of accidents Reduced braking efficiency caused by worn brake linings.
- Change worn brake linings immediately. (Your authorized Husqvarna workshop will be glad to help.)

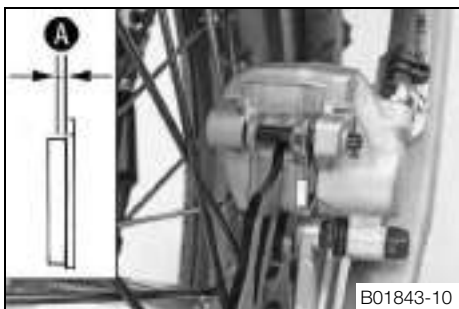

- Check the brake linings for minimum thickness A.

Minimum thickness A	≥ 1 mm (≥ 0.04 in)
---------------------	--------------------

- » If the minimum thickness is less than specified:
 - Change the rear brake linings. ☞ (☞ p. 62)
- Check the brake linings for damage and cracking.
 - » If damage or cracking is visible:
 - Change the rear brake linings. ☞ (☞ p. 62)

12.13 Changing the rear brake linings ☞

- Warning**
Danger of accident Brake system failure.
- Maintenance work and repairs must be carried out professionally. (Your authorized Husqvarna workshop will be glad to help.)

- Warning**
Skin irritation Brake fluid can cause skin irritation on contact.
- Avoid contact with skin and eyes, and keep out of the reach of children.
 - Wear suitable protective clothing and goggles.
 - If brake fluid comes into contact with the eyes, flush the eyes thoroughly with water and consult a physician immediately.

- Warning**
Danger of accidents Reduced braking efficiency due to old brake fluid.
- Change the brake fluid of the front and rear brake according to the service schedule. (Your authorized Husqvarna workshop will be glad to help.)

- Warning**
Danger of accidents Reduced braking efficiency due to oil or grease on the brake discs.
- Always keep the brake discs free of oil and grease, and clean them with brake cleaner when necessary.

- Warning**
Danger of accidents Reduced braking efficiency due to the use of non-approved brake linings.
- Brake linings available in accessories stores often have not been tested and approved for use in Husqvarna vehicles. The structure and friction coefficient of the brake linings and thus their brake power may vary greatly from that of original Husqvarna brake linings. If brake linings that differ from the original equipment are used, it cannot be guaranteed that these are in keeping with the original homologation. In this case, the vehicle will not correspond to its condition at delivery and the warranty shall be void.

- Warning**
Environmental hazard Hazardous substances cause environmental damage.
- Oil, grease, filters, fuel, cleaners, brake fluid, etc., should be disposed of as stipulated in applicable regulations.

- i Info**
 Never use DOT 5 brake fluid! It is silicone-based and purple in color. Oil seals and brake lines are not designed for DOT 5 brake fluid.
 Avoid contact between brake fluid and painted parts. Brake fluid attacks paint!
 Use only clean brake fluid from a sealed container!

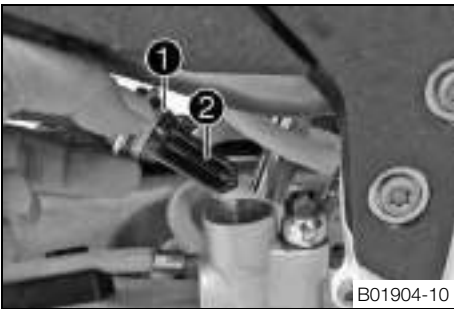

B01904-10

- Stand the vehicle upright.
- Remove screw cap ① with membrane ② and the O-ring.

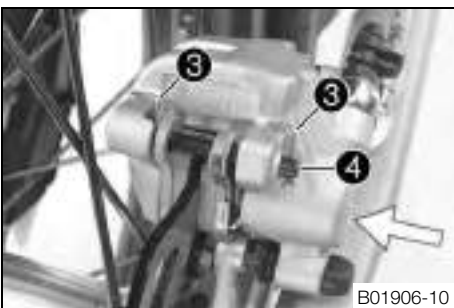

B01906-10

- Manually press the brake caliper to the brake disc to push back the brake piston. Ensure that brake fluid does not flow out of the brake fluid reservoir, extracting it by suction if it does.

- i Info**
 Make sure when pushing back the brake piston that you do not press the brake caliper against the spokes.

- Remove cotter pins ③, pull out pin ④, and remove the brake linings.
- Clean the brake caliper and brake caliper support.
- Check that leaf spring ⑤ in the brake caliper and sliding plate ⑥ in the brake caliper support are seated correctly.

- i Info**
 The arrow on the leaf spring points in the rotation direction of the brake disc.

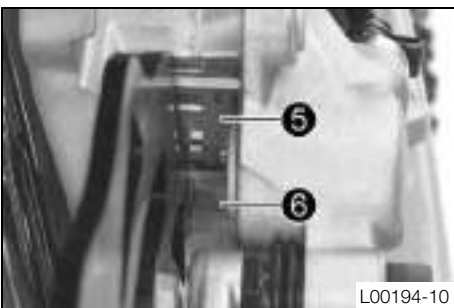

L00194-10

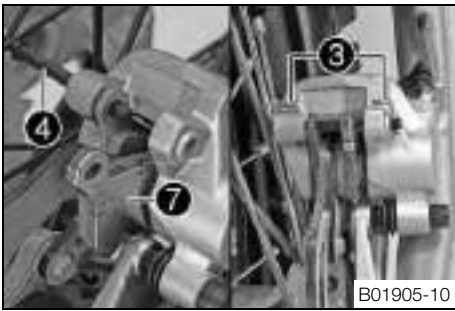

- Insert the brake linings, insert pin 4, and mount cotter pins 3.

i Info
Always change the brake linings in pairs.

i Info
Make sure that decoupling plate 7 is mounted on the piston side of the brake lining.

-
- Operate the foot brake lever several times until the brake linings are lying correctly against the brake disc and there is a pressure point.

- Add brake fluid to level A.

Brake fluid DOT 4 / DOT 5.1 (☞ p. 100)

-
- Mount and tighten screw cap 1 with membrane 2 and the O-ring.

i Info
Clean up overflowed or spilt brake fluid immediately with water.

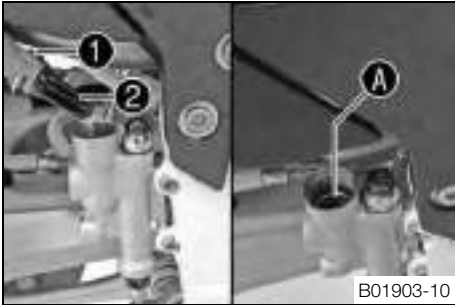

13.1 Removing the front wheel



Preparatory work

- Raise the motorcycle with the lift stand. (p. 33)

Main work

- Press the brake caliper onto the brake disc by hand in order to push back the brake pistons.

Info

Make sure when pushing back the brake pistons that you do not press the brake caliper against the spokes.

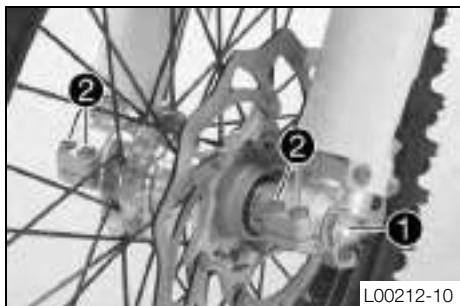

- Loosen screw 1 by several rotations.
- Loosen screws 2.
- Press on screw 1 to push the wheel spindle out of the axle clamp.
- Remove screw 1.

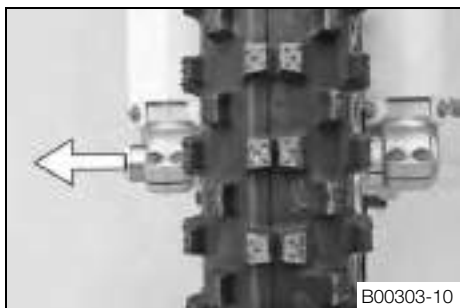

- Holding the front wheel, withdraw the wheel spindle. Take the front wheel out of the fork.

Info

Do not pull the hand brake lever when the front wheel is removed. Always lay the wheel down in such a way that the brake disc is not damaged.

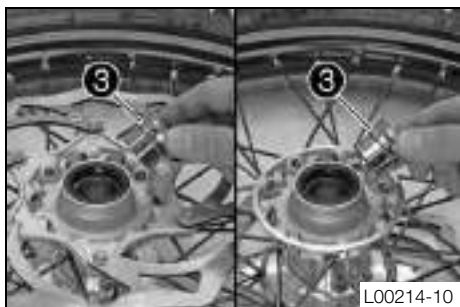

- Remove spacers 3.

13.2 Installing the front wheel



Warning

Danger of accidents Reduced braking efficiency due to oil or grease on the brake discs.

- Always keep the brake discs free of oil and grease, and clean them with brake cleaner when necessary.

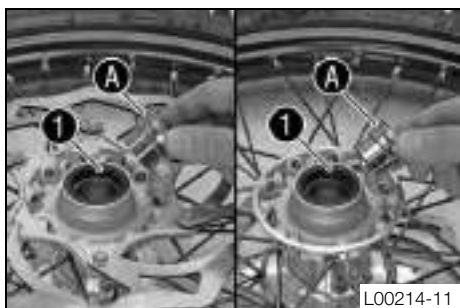

- Check the wheel bearing for damage and wear.
 - » If the wheel bearing is damaged or worn:
 - Change the wheel bearing.
- Clean and grease shaft seal rings 1 and bearing surface A of the spacers.
- Insert the spacers.
- Position the front wheel and insert the wheel spindle.
 - ✓ The brake linings are correctly positioned.

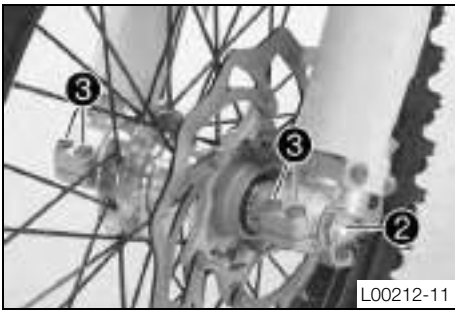

- Mount and tighten screw ②.

Guideline

Screw, front wheel spindle	M24x1.5	45 Nm (33.2 lbf ft)
----------------------------	---------	---------------------

- Operate the hand brake lever several times until the brake linings are lying correctly against the brake disc.
- Remove the motorcycle from the lift stand. (☛ p. 33)
- Pull the front wheel brake and push down hard on the fork several times.
 - ✓ The fork legs become aligned.
- Tighten screws ③.

Guideline

Screw, fork stub	M8	15 Nm (11.1 lbf ft)
------------------	----	---------------------

13.3 Removing the rear wheel ☞

Preparatory work

- Raise the motorcycle with the lift stand. (☛ p. 33)

Main work

- Press the brake caliper onto the brake disc by hand in order to push back the brake piston.

i Info

Make sure when pushing back the brake piston that you do not press the brake caliper against the spokes.

- Remove nut ①.
- Remove chain adjuster ②. Withdraw wheel spindle ③ only enough to allow the rear wheel to be pushed forward.
- Push the rear wheel forward as far as possible. Remove the chain from the rear sprocket.

i Info

Protect the motorcycle and its attachments against damage by covering them.

- Holding the rear wheel, withdraw the wheel spindle. Take the rear wheel out of the swingarm.

i Info

Do not operate the foot brake when the rear wheel is removed. Always lay the wheel down in such a way that the brake disc is not damaged.

- Remove spacers ④.

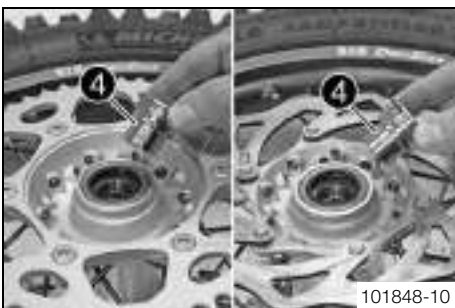
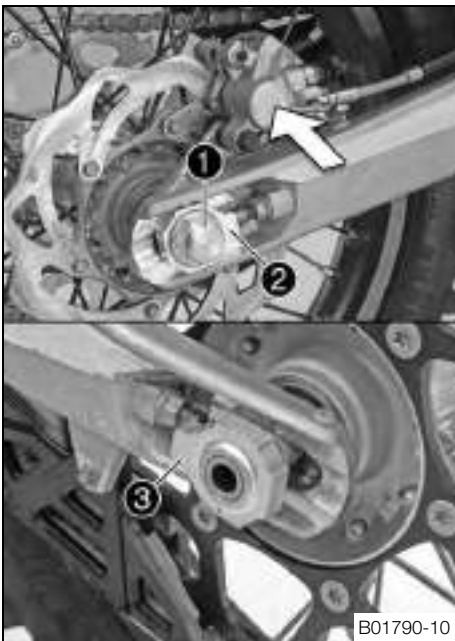

13.4 Installing the rear wheel

Warning

Danger of accidents Reduced braking efficiency due to oil or grease on the brake discs.

- Always keep the brake discs free of oil and grease, and clean them with brake cleaner when necessary.

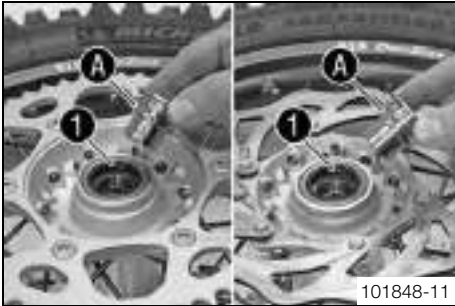

Main work

- Check the wheel bearing for damage and wear.
 - » If the wheel bearing is damaged or worn:
 - Change the wheel bearing.
- Clean and grease shaft seal rings **1** and bearing surface **A** of the spacers.
- Insert the spacers.



- Lift the rear wheel into the swing arm, position it, and insert wheel spindle **2**.
- Apply the chain.



- Position chain adjuster **3**. Mount nut **4**, but do not tighten it yet.
- Make sure that chain adjusters **3** are fitted correctly on adjusting screws **5**.
- Check the chain tension. (☛ p. 48)
- Tighten nut **4**.

Guideline

Nut, rear wheel spindle	M20x1.5	80 Nm (59 lbf ft)
-------------------------	---------	-------------------

Info

The wide adjustment range of the chain adjusters (32 mm (1.18 in)) enables different secondary ratios with the same chain length. Chain adjusters **3** can be turned by 180°.

- Operate the foot brake lever several times until the brake linings are lying correctly against the brake disc and there is a pressure point.

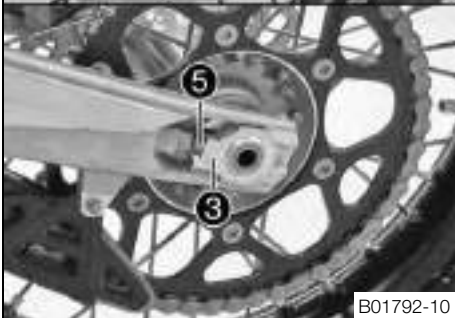

Finishing work

- Remove the motorcycle from the lift stand. (☛ p. 33)

13.5 Checking the tire condition

Info

Only mount tires approved and/or recommended by Husqvarna. Other tires could have a negative effect on handling characteristics. The type, condition and air pressure of the tires all have an important impact on the handling characteristics of the motorcycle. The front and rear wheels must be mounted with tires with similar profiles. Worn tires have a negative effect on handling characteristics, especially on wet surfaces.

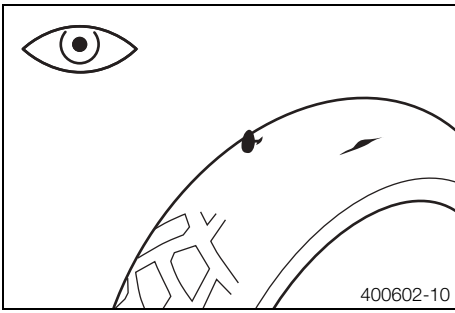

- Check the front and rear tires for cuts, run-in objects and other damage.
 - » If the tire exhibits cuts, run-in objects or other damage:
 - Change the tire.
- Check the depth of the tread.



Info

Note local national regulations concerning the minimum tread depth.

Minimum tread depth	≥ 2 mm (≥ 0.08 in)
---------------------	--------------------

- » If the tread depth is less than the minimum permissible depth:
 - Change the tire.
- Check the tire age.



Info

The tire's date of manufacture is usually part of the tire markings and is indicated by the last four digits of the **DOT** marking. The first two digits indicate the week of manufacture and the last two digits the year of manufacture. Husqvarna recommends that the tires be changed after 5 years at the latest, regardless of the actual state of wear.

- » If the tire is older than five years:
 - Change the tire.

13.6 Checking the tire air pressure



Info

Low tire air pressure leads to abnormal wear and overheating of the tire. Correct tire air pressure ensures optimal riding comfort and maximum tire service life.

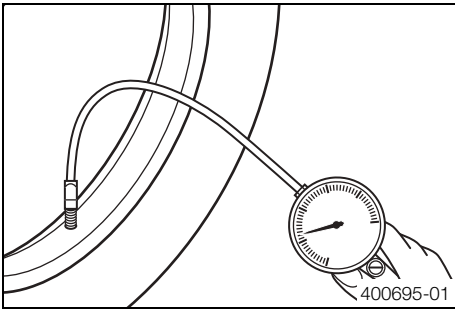

- Remove the dust cap.
- Check the tire air pressure when the tires are cold.

Tire air pressure off road	
Front	1.0 bar (15 psi)
Rear	1.0 bar (15 psi)

- » If the tire pressure does not meet specifications:
 - Correct the tire pressure.
- Mount the dust cap.

13.7 Checking the spoke tension



Warning

Danger of accidents Instable handling due to incorrect spoke tension.

- Ensure that the spoke tension is correct. (Your authorized Husqvarna workshop will be glad to help.)



Info

A loose spoke causes wheel imbalance and rapidly leads to more loose spokes. If the spokes are too tight, they can break due to local overload. Check the spoke tension regularly, especially on a new motorcycle.

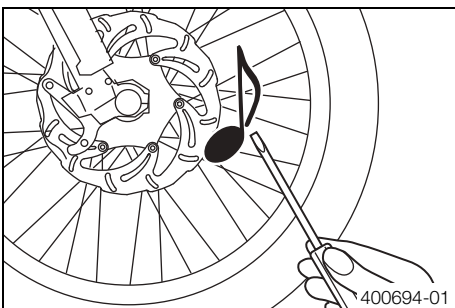

- Briefly strike each spoke with the tip of a screwdriver.



Info

The tone frequency depends on the length of the spoke and the spoke diameter. If you hear different tone frequencies from different spokes of equal length and diameter, this is an indication of different spoke tensions.

You should hear a high note.

- » If the spoke tension varies:
 - Correct the spoke tension. 
- Check the spoke torque.

Guideline

Spoke nipple, front wheel	M4.5	5... 6 Nm (3.7... 4.4 lbf ft)
Spoke nipple, rear wheel	M4.5	5... 6 Nm (3.7... 4.4 lbf ft)

Torque wrench with various accessories in set (58429094000)

14.1 Cooling system

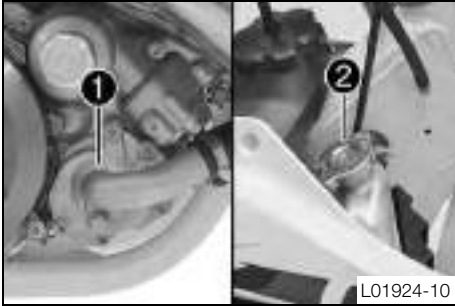

(125 TC EU)

Water pump **1** in the engine circulates the coolant. The pressure resulting from the warming of the cooling system is regulated by a valve in radiator cap **2**. This ensures that operating the vehicle at the specified coolant temperature will not result in a risk of malfunctions.

120 °C (248 °F)

Cooling is effected by the air stream. The lower the speed, the less the cooling effect. Dirty cooling fins also reduce the cooling effect.

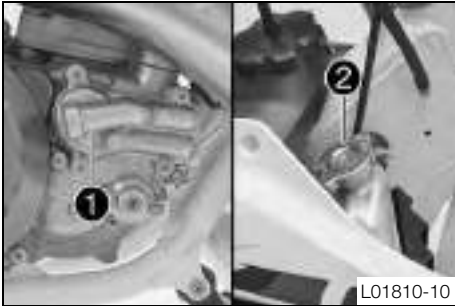

(250 TC EU)

Water pump **1** in the engine circulates the coolant. The pressure resulting from the warming of the cooling system is regulated by a valve in radiator cap **2**. This ensures that operating the vehicle at the specified coolant temperature will not result in a risk of malfunctions.

120 °C (248 °F)

Cooling is effected by the air stream. The lower the speed, the less the cooling effect. Dirty cooling fins also reduce the cooling effect.

14.2 Radiator cover



The radiator cover is mounted in front of the left radiator between the radiator shield and radiator.

The radiator cover keeps the coolant temperature in the correct range.

Coolant temperature	65... 70 °C (149... 158 °F)
---------------------	-----------------------------

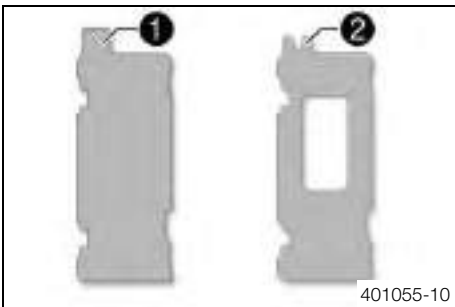

The radiator cover is installed in front of the left radiator, depending on the ambient temperature.

Radiator cover 1 without notch	< 7 °C (< 45 °F)
---------------------------------------	------------------

Radiator cover 2 with notch	7... 16 °C (45... 61 °F)
------------------------------------	--------------------------

Without radiator cover	> 16 °C (> 61 °F)
------------------------	-------------------

i Info

Do not use both radiator covers at the same time.

14.3 Installing the radiator cover

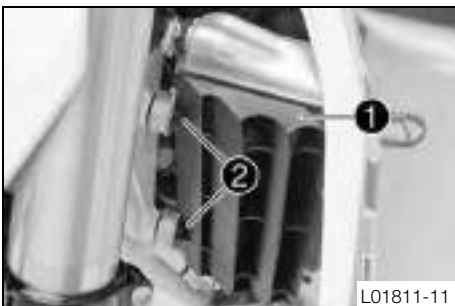

- Detach radiator shield **1** at mounting points **2** and remove it.

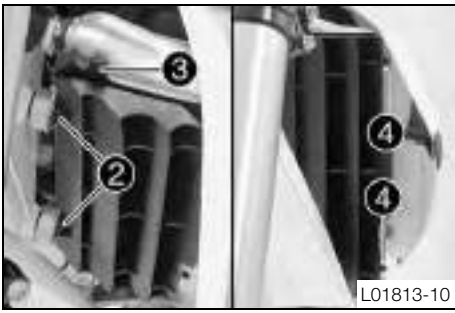

- Position the corresponding radiator cover **3** and attach the radiator shield at holding lugs **4**. Attach mounting points **2** at the radiator.

14.4 Removing the radiator cover

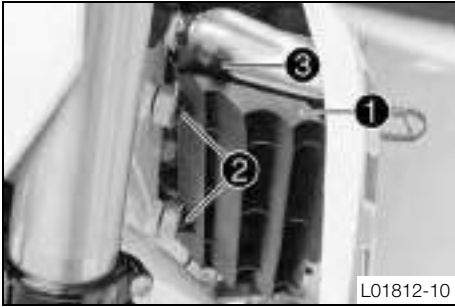

- Detach radiator shield **1** at mounting points **2** and remove it. Remove radiator cover **3**.

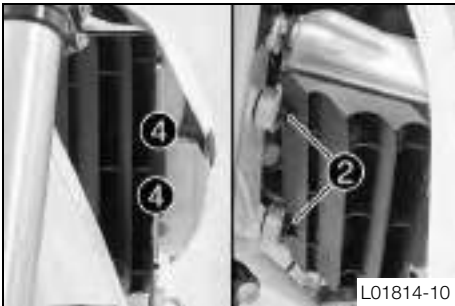

- Attach the radiator shield at holding lugs **4**. Attach mounting points **2** at the radiator.

14.5 Checking the antifreeze and coolant level

- Warning**
Danger of scalding During motorcycle operation, the coolant gets very hot and is under pressure.
- Do not remove the radiator cap, radiator hoses or other cooling system components when the engine is hot. Allow the engine and cooling system to cool down. In case of scalding, rinse immediately with lukewarm water.

- Warning**
Danger of poisoning Coolant is poisonous and a health hazard.
- Coolant must not come into contact with the skin, eyes, or clothing. If contact occurs with the eyes, rinse with water immediately and contact a physician. Immediately clean contaminated areas on the skin with soap and water. If coolant is swallowed, contact a physician immediately. Change clothing that is contaminated with coolant. Keep coolant out of reach of children.

Condition

The engine is cold.

- Stand the motorcycle upright on a horizontal surface.
- Remove the radiator cap.
- Check the coolant antifreeze.

-25... -45 °C (-13... -49 °F)

» If the coolant antifreeze does not meet specifications:

- Correct the coolant antifreeze.
- Check the coolant level in the radiator.

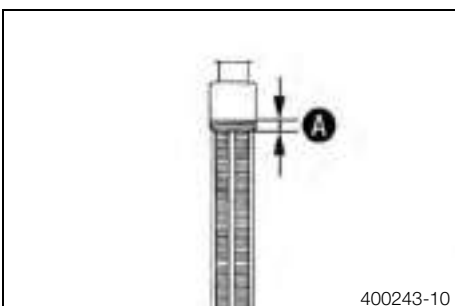

Coolant level A above the radiator fins.	10 mm (0.39 in)
-------------------------------------------------	-----------------

- » If the level of the coolant does not meet specifications:
 - Correct the coolant level.

Alternative 1

Coolant (☛ p. 100)

Alternative 2

Coolant (mixed ready to use) (☛ p. 100)

- Mount the radiator cap.

14.6 Checking the coolant level

Warning
Danger of scalding During motorcycle operation, the coolant gets very hot and is under pressure.

- Do not remove the radiator cap, radiator hoses or other cooling system components when the engine is hot. Allow the engine and cooling system to cool down. In case of scalding, rinse immediately with lukewarm water.

Warning
Danger of poisoning Coolant is poisonous and a health hazard.

- Coolant must not come into contact with the skin, eyes, or clothing. If contact occurs with the eyes, rinse with water immediately and contact a physician. Immediately clean contaminated areas on the skin with soap and water. If coolant is swallowed, contact a physician immediately. Change clothing that is contaminated with coolant. Keep coolant out of reach of children.

Condition

The engine is cold.

- Stand the motorcycle upright on a horizontal surface.
- Remove the radiator cap.
- Check the coolant level in the radiator.

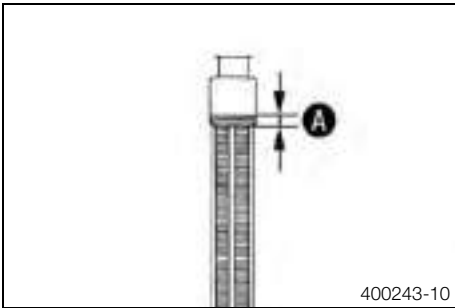

Coolant level A above the radiator fins.	10 mm (0.39 in)
-------------------------------------------------	-----------------

- » If the level of the coolant does not meet specifications:
 - Correct the coolant level.

Alternative 1

Coolant (☛ p. 100)

Alternative 2

Coolant (mixed ready to use) (☛ p. 100)

- Mount the radiator cap.

14.7 Draining the coolant ☞

Warning
Danger of scalding During motorcycle operation, the coolant gets very hot and is under pressure.

- Do not remove the radiator cap, radiator hoses or other cooling system components when the engine is hot. Allow the engine and cooling system to cool down. In case of scalding, rinse immediately with lukewarm water.

Warning
Danger of poisoning Coolant is poisonous and a health hazard.

- Coolant must not come into contact with the skin, eyes, or clothing. If contact occurs with the eyes, rinse with water immediately and contact a physician. Immediately clean contaminated areas on the skin with soap and water. If coolant is swallowed, contact a physician immediately. Change clothing that is contaminated with coolant. Keep coolant out of reach of children.

Condition

The engine is cold.

- Position the motorcycle upright.
- Place a suitable container under the water pump cover.

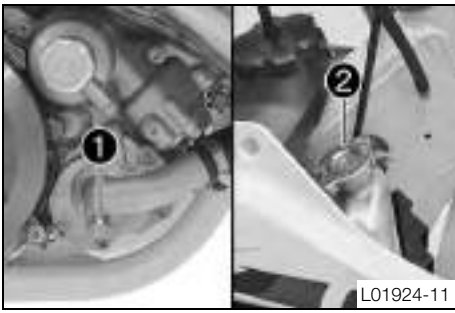

L01924-11

(125 TC EU)

- Remove screw 1. Take off radiator cap 2.
- Completely drain the coolant.
- Mount and tighten screw 1 with a new seal ring.

Guideline

Drain plug, water pump cover	M10x1	15 Nm (11.1 lbf ft)
------------------------------	-------	------------------------

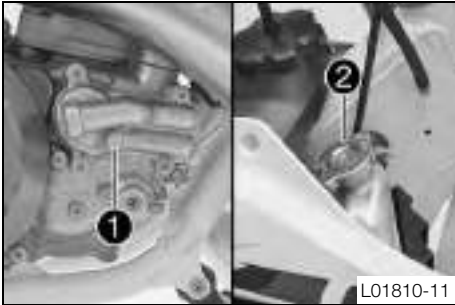

L01810-11

(250 TC EU)

- Remove screw 1. Take off radiator cap 2.
- Completely drain the coolant.
- Mount and tighten screw 1 with a new seal ring.

Guideline

Drain plug, water pump cover	M10x1	15 Nm (11.1 lbf ft)
------------------------------	-------	------------------------

14.8 Refilling with coolant



Warning

Danger of poisoning Coolant is poisonous and a health hazard.

- Coolant must not come into contact with the skin, eyes, or clothing. If contact occurs with the eyes, rinse with water immediately and contact a physician. Immediately clean contaminated areas on the skin with soap and water. If coolant is swallowed, contact a physician immediately. Change clothing that is contaminated with coolant. Keep coolant out of reach of children.

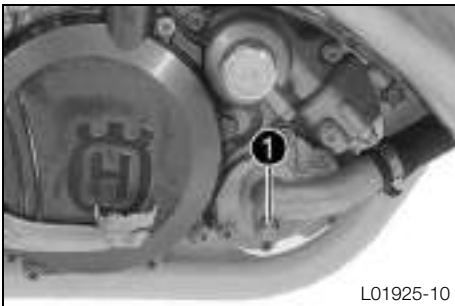

L01925-10

(125 TC EU)

- Make sure that screw 1 is tightened.
- Position the motorcycle upright.
- Completely fill the radiator with coolant.

Coolant	1.2 l (1.3 qt.)	Coolant (☛ p. 100)
		Coolant (mixed ready to use) (☛ p. 100)

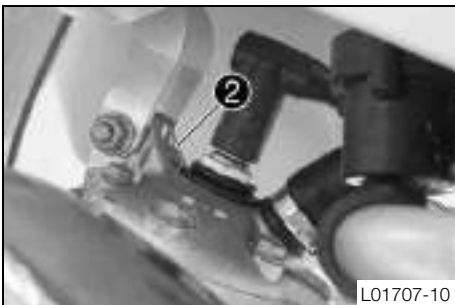

L01707-10

- Loosen screw 2 until coolant that does not contain any bubbles escapes. Replace and retighten screw 2.

Guideline

Bleeder screw, cylinder head	M6	10 Nm (7.4 lbf ft)
------------------------------	----	--------------------



L01815-10

(250 TC EU)

- Make sure that screw 1 is tightened.
- Position the motorcycle upright.
- Completely fill the radiator with coolant.

Coolant	1.2 l (1.3 qt.)	Coolant (☛ p. 100)
		Coolant (mixed ready to use) (☛ p. 100)

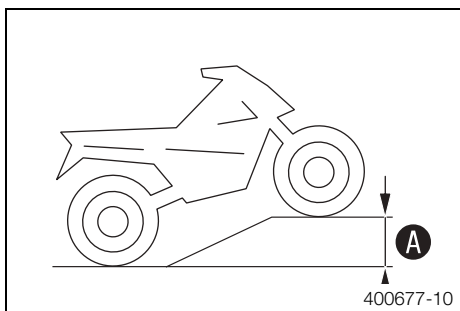

- Move the vehicle into the position shown and prevent it from rolling away. Height difference **A** must be reached.

Guideline

Height difference A	75 cm (29.5 in)
----------------------------	-----------------

i Info
 For all of the air to be able to escape from the cooling system, the vehicle must be raised at the front. If the cooling system is poorly de-aerated, its cooling power will be reduced and the engine may overheat.

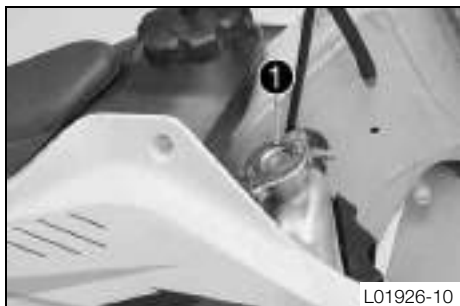

- Return the vehicle to the horizontal position.
- Fill the radiator completely with coolant.
- Mount radiator cap **2**.
- Run the engine until it is warm.
- Check the coolant level. (☛ p. 72)

15.1 Checking the play in the throttle cable

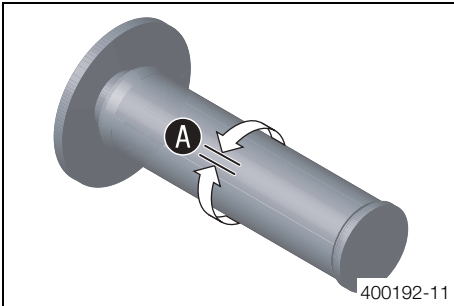

- Check the throttle grip for smooth operation.
- Move the handlebar to the straight-ahead position. Move the throttle grip back and forth slightly to determine the play in throttle cable **A**.

Play in throttle cable	2... 3 mm (0.08... 0.12 in)
------------------------	-----------------------------

- » If the throttle cable play does not meet specifications:
 - Adjust the play in the throttle cable. 🛠️ (☞ p. 75)



Danger

Danger of poisoning Exhaust gases are toxic and inhaling them may result in unconsciousness and/or death.

- When running the engine, always make sure there is sufficient ventilation, and do not start or run the engine in an enclosed space without an effective exhaust extraction system.

- Start the engine and let it run idle. Move the handlebar to and fro over the entire steering range.

The idle speed must not change.

- » If the idle speed changes:
 - Adjust the play in the throttle cable. 🛠️ (☞ p. 75)

15.2 Adjusting the play in the throttle cable 🛠️

Preparatory work

- Remove the seat. (☞ p. 42)
- Remove the fuel tank. 🛠️ (☞ p. 45)
- Check the routing of the throttle cable. (☞ p. 51)

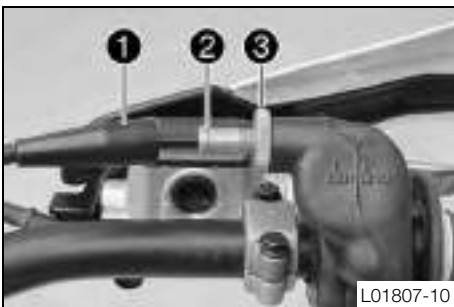

Main work

- Move the handlebar to the straight-ahead position.
- Push back sleeve **1**.
- Ensure that the throttle cable sleeve is pushed all the way into barrel adjuster **2**.
- Loosen nut **3**.

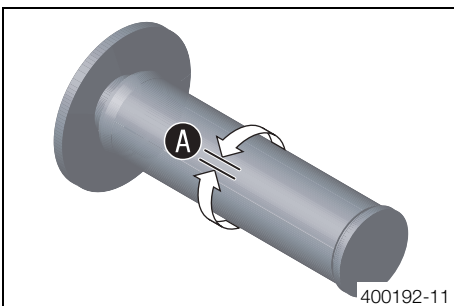

- Turn adjusting screw **2** in such a way there is throttle cable play **A** in the throttle grip.

Guideline

Play in throttle cable	2... 3 mm (0.08... 0.12 in)
------------------------	-----------------------------

- Tighten nut **3**.
- Slide on sleeve **1**.

Finishing work

- Check the throttle grip for smooth operation.
- Install the fuel tank. 🛠️ (☞ p. 46)
- Mount the seat. (☞ p. 42)
- Check the play in the throttle cable. (☞ p. 75)

15.3 Carburetor - idle

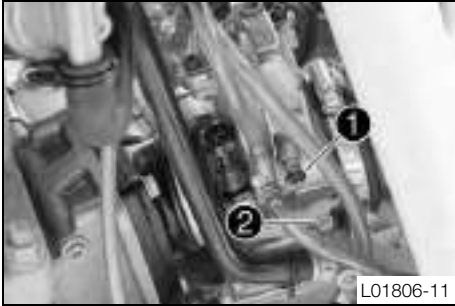

The idle setting of the carburetor has a big influence on the starting behavior, stable idling and the response to throttle opening. This means that an engine with a correctly set idle speed is easier to start than if the idle is set wrongly.

i Info
The carburetor and its components are subject to increased wear caused by engine vibration. Wear can result in malfunctioning.

The factory setting for the carburetor is set for the following values.

(125 TC EU)

Elevation above sea level	500 m (1,640 ft)
Ambient temperature	20 °C (68 °F)
Super unleaded (98 octane) mixed with 2-stroke engine oil (1:40)	(☛ p. 101)

(250 TC EU)

Elevation above sea level	500 m (1,640 ft)
Ambient temperature	20 °C (68 °F)
Super unleaded (95 octane) mixed with 2-stroke engine oil (1:60)	(☛ p. 101)

The idle speed is adjusted with adjusting screw **1**.

The idle mixture is adjusted with the idle air adjusting screw **2**.

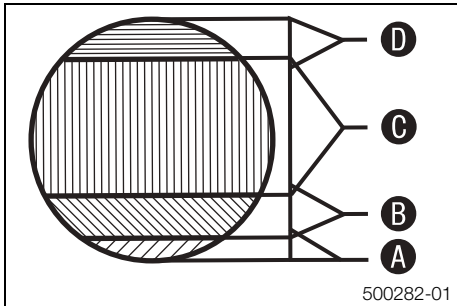

Idle air range A

Operation with the throttle slide closed. This range is influenced by adjusting screw **1** and the idle air adjusting screw **2**.

Transition range B

Behavior of the engine when the throttle slide is being opened. This range is influenced by the idling jet and by the form of the throttle slide.

If the engine sputters and smokes heavily when it starts despite a good idle and part-load setting, and if it abruptly reaches full power at a high rpm, the carburetor setting is too rich, or the float level is too high or the float needle valve is leaky.

Part-load range C

Operation with the throttle slide partially open. This range is influenced by the jet needle (form and position). The idle setting influences the engine tuning in the lower range, and the main jet influences the engine tuning in the upper range.

If the engine stutters when accelerating with a partially open throttle slide, the jet needle must be lowered by one notch. If the engine knocks when accelerating at the full power rpm range, the jet needle must be raised. If the above events occur on idle or just above it, the idle system must be set to a leaner setting if the engine is stuttering or to a richer setting if the engine is knocking.

Full-load range D

Operation with the throttle slide open (full throttle). This range is influenced by the main jet and jet needle.

If the insulator of a new spark plug is very light-colored or white after a brief ride at full throttle, or if the engine knocks, a larger main jet needs to be used. If the insulator is dark brown or sooty, a smaller main jet needs to be used.

15.4 Carburetor - adjusting the idle speed

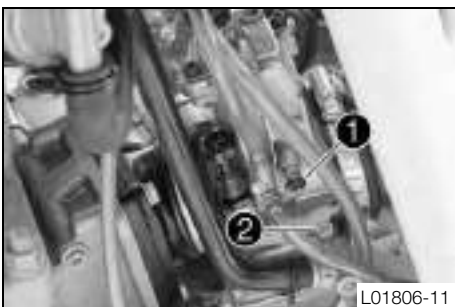

- Screw in idle air adjusting screw **2** all the way and turn it to the specified basic position.

Guideline

Idle air adjusting screw (125 TC EU)	
Open	2 turns
Idle air adjusting screw (250 TC EU)	
Open	2 turns

- Run the engine until warm.

Guideline

Warm-up time	≥ 5 min
--------------	---------



Danger

Danger of poisoning Exhaust gases are toxic and inhaling them may result in unconsciousness and/or death.

- When running the engine, always make sure there is sufficient ventilation, and do not start or run the engine in an enclosed space without an effective exhaust extraction system.

- Adjust the idle speed with adjusting screw ❶.

Guideline

Choke function deactivated – The choke lever is pushed in to the stop. (☞ p. 13)

Idle speed	1,400... 1,500 rpm
------------	--------------------

- Turn idle air adjusting screw ❷ slowly in a clockwise direction until the idle speed begins to fall.
- Note the position and turn the idle air adjusting screw slowly counterclockwise until the idle speed falls again.
- Adjust to the point between these two positions with the highest idle speed.



Info

If there is a large engine speed rise, reduce the idle speed to a normal level and repeat the above steps.

If the procedure described here does not lead to satisfactory results, the cause may be a wrongly dimensioned idling jet.

If you can turn the idle air adjusting screw to the end without any change of engine speed, you need to install a smaller idling jet.

After changing the idling jet, repeat the adjusting steps from the beginning. Following extreme air temperature or altitude changes, adjust the idle speed again.

15.5 Emptying the carburetor float chamber ☞



Danger

Fire hazard Fuel is highly flammable.

- Never refuel the vehicle near open flames or burning cigarettes, and always switch off the engine first. Be careful that no fuel is spilt, especially on hot vehicle components. Clean up spilt fuel immediately.
- The fuel in the fuel tank expands when warm and may emerge if overfilled. Follow the instructions on refueling.



Warning

Danger of poisoning Fuel is poisonous and a health hazard.

- Fuel must not come into contact with the skin, eyes, or clothing. Do not breathe in the fuel vapors. If contact occurs with the eyes, rinse with water immediately and contact a physician. Immediately clean contaminated areas on the skin with soap and water. If fuel is swallowed, contact a physician immediately. Change clothing that is contaminated with fuel. Store fuel properly in a suitable canister and keep away from children.



Warning

Environmental hazard Improper handling of fuel is a danger to the environment.

- Do not allow fuel to get into the ground water, the ground, or the sewage system.



Info

Carry out this work with a cold engine.

Water in the float chamber results in malfunctioning.

Preparatory work

- Turn handle ❶ of the fuel tap to the **OFF** position. (Figure L01808-10☞ p. 13)
- ✓ Fuel no longer flows from the fuel tank to the carburetor.

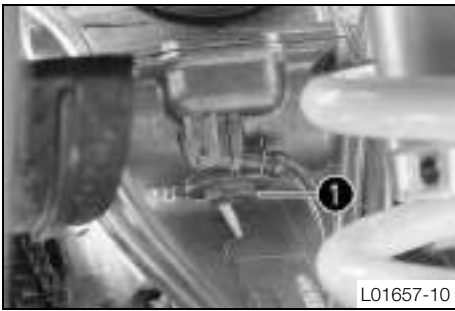

Main work

- Place a cloth beneath the carburetor to soak up emerging fuel.
- Remove plug ❶.
- Completely drain the fuel.
- Mount and tighten the plug.

15.6 Plug-in connection, ignition timing map (125 TC EU)



Plug-in connection ❶ is located under the fuel tank on the frame.

Possible states

- Performance – The plug-in connection is connected to achieve higher performance.
- Soft – The plug-in connection is disconnected to achieve better rideability.

15.7 Changing the ignition curve

**Change the ignition curve from Performance to Soft.
(125 TC EU)**

- Disconnect plug-in connection ❶. (Figure L01900-10 ➔ p. 78)
- ✓ Soft – better rideability

**Change the ignition curve from Soft to Performance.
(125 TC EU)**

- Connect plug-in connection ❶. (Figure L01900-10 ➔ p. 78)
- ✓ Performance – better performance

**Change the ignition curve from Performance to Soft.
(250 TC EU)**

- Turn lever ❶ to position II. (Figure L01818-10 ➔ p. 12)
- ✓ Soft – better rideability

**Change the ignition curve from Soft to Performance.
(250 TC EU)**

- Turn lever ❶ to position I. (Figure L01818-10 ➔ p. 12)
- ✓ Performance – better performance

15.8 Checking the basic position of the shift lever

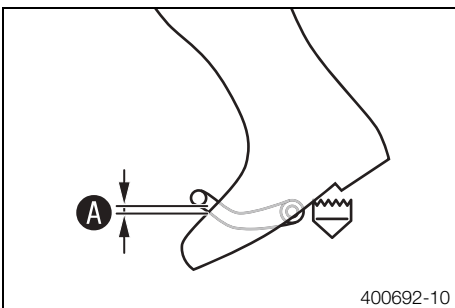

- Sit on the vehicle in the riding position and determine the distance A between the upper edge of your boot and the shift lever.

Distance between shift lever and upper edge of boot	10... 20 mm (0.39... 0.79 in)
-----------------------------------------------------	-------------------------------

- » If the distance does not meet specifications:
 - Adjust the basic position of the shift lever. ➔ (➔ p. 79)

15.9 Adjusting the basic position of the shift lever

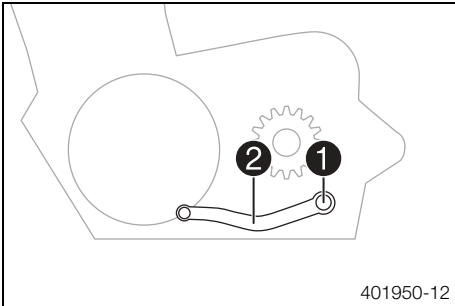

- Remove screw ❶ and take off shift lever ❷.

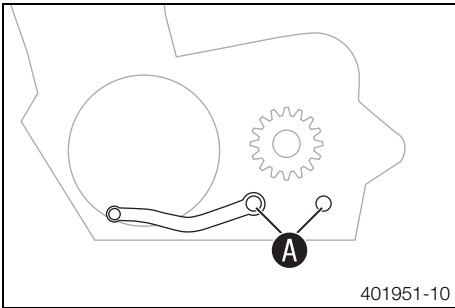

- Clean gear teeth A of the shift lever and shift shaft.
- Mount the shift lever on the shift shaft in the required position and engage the gearing.

Info

The range of adjustment is limited.

The shift lever must not come into contact with any other vehicle components during the shift procedure.

- Mount and tighten the screw.

Guideline

Screw, shift lever	M6	14 Nm (10.3 lbf ft)	Loctite® 243™
--------------------	----	------------------------	----------------------

15.10 Engine characteristic - auxiliary spring (250 TC EU)

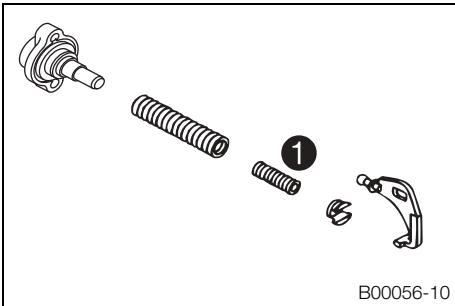

The auxiliary spring is located on the right side of the engine below the water pump cover.

Possible states

- Auxiliary spring with yellow marking – Auxiliary spring mounted at the factory with medium tuning (standard) for good rideability.
- Auxiliary spring with green marking – Auxiliary spring contained in the separate enclosure for softer performance.
- Auxiliary spring with red marking – Auxiliary spring contained in the separate enclosure for more aggressive performance.

The engine characteristic can be influenced by different spring strengths of the auxiliary spring ❶.

15.11 Engine characteristic - set the auxiliary spring (250 TC EU)

Warning

Danger of burns Some vehicle components become very hot when the vehicle is operated.

- Do not touch hot components such as exhaust system, radiator, engine, shock absorber, and the brake system. Allow these components to cool down before starting work on them.

Preparatory work

- Tilt the motorcycle approx. 45° to the left and secure it to prevent it from falling.

Main work

- Remove screws ❶.



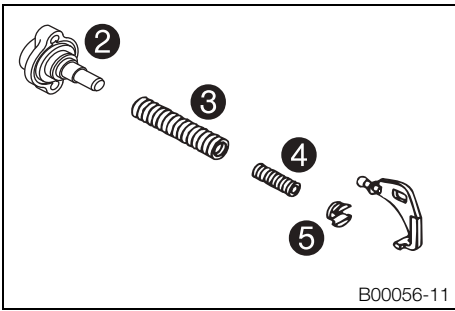

- Take cap **2**, adjusting spring **3**, auxiliary spring **4**, and spring insert **5** out of the clutch cover.
- Pull both springs off of the spring insert.

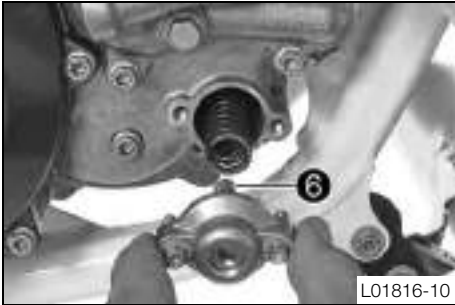

- Mount the required auxiliary spring **4** and adjusting spring **3** and slide them into the clutch cover together.

Auxiliary spring with yellow marking (54637072300)
Auxiliary spring with green marking (54837072100)
Auxiliary spring with red marking (54837072000)

✓ The recess in spring insert **5** engages in the angle lever.

i Info
Screw **6** must not be turned as this would worsen the engine characteristic.

- Check the O-ring in the cap.
- Position the cap.
- Mount and tighten the screws.

Guideline

Screw, exhaust control cover	M5	6 Nm (4.4 lbf ft)
------------------------------	----	-------------------

16.1 Checking the gear oil level

Info

The gear oil level must be checked while the engine is cold.



Preparatory work

- Stand the motorcycle upright on a horizontal surface.

Main work

(125 TC EU)

- Remove screw ① from the opening used to check the gear oil level.
- Check the gear oil level.

A small quantity of gear oil should flow out of the opening.

- » If gear oil does not flow out:
 - Add gear oil. 🛠️ (📄 p. 83)

- Mount and tighten the screw in the opening used to check the gear oil level.

Guideline

Screw, gear oil level check	M6	10 Nm (7.4 lbf ft)
-----------------------------	----	--------------------



(250 TC EU)

- Remove screw ① from the opening used to check the gear oil level.
- Check the gear oil level.

A small quantity of gear oil should flow out of the opening.

- » If gear oil does not flow out:
 - Add gear oil. 🛠️ (📄 p. 83)

- Mount and tighten the screw in the opening used to check the gear oil level.

Guideline

Screw, gear oil level check	M6	10 Nm (7.4 lbf ft)
-----------------------------	----	--------------------

16.2 Changing the gear oil 🛠️

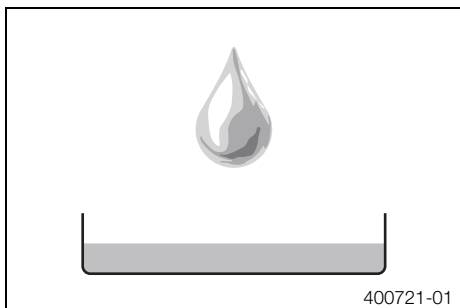

- Drain the gear oil. 🛠️ (📄 p. 82)

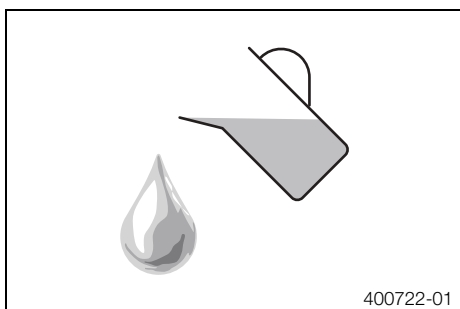

- Refill with gear oil. 🛠️ (📄 p. 82)

16.3 Draining the gear oil

Warning

Danger of scalding Engine oil and gear oil get very hot when the motorcycle is ridden.

- Wear appropriate protective clothing and safety gloves. In case of burns, rinse immediately with lukewarm water.

Warning

Environmental hazard Hazardous substances cause environmental damage.

- Oil, grease, filters, fuel, cleaners, brake fluid, etc., should be disposed of as stipulated in applicable regulations.

Info

Only drain the gear oil while the engine is warm.

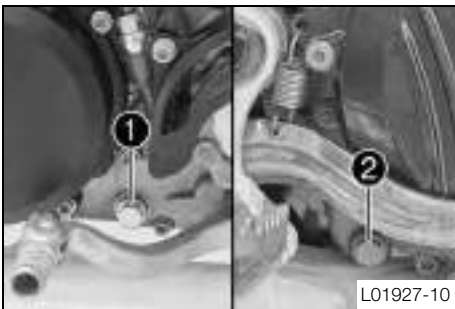

Preparatory work

- Park the motorcycle on a level surface.
- Place a suitable container under the engine.

Main work (125 TC EU)

- Remove the gear oil drain plug with magnet ①.
- Remove gear oil drain plug ②.
- Completely drain the gear oil.
- Clean the gear oil drain plug thoroughly.
- Clean the sealing area on the engine.
- Mount the gear oil drain plug with magnet ① and the seal ring and tighten.

Guideline

Gear oil drain plug with magnet	M12x1.5	20 Nm (14.8 lbf ft)
---------------------------------	---------	------------------------

- Mount gear oil drain plug ② with the seal ring and tighten.

Guideline

Gear oil drain plug	M10x1	15 Nm (11.1 lbf ft)
---------------------	-------	------------------------



(250 TC EU)

- Remove the gear oil drain plug with magnet ①.
- Completely drain the gear oil.
- Clean the gear oil drain plug with the magnet thoroughly.
- Clean the sealing area on the engine.
- Mount the gear oil drain plug with magnet ① and the seal ring and tighten.

Guideline

Gear oil drain plug with magnet	M12x1.5	20 Nm (14.8 lbf ft)
---------------------------------	---------	------------------------

16.4 Refilling with gear oil

Info

Too little gear oil or poor-quality oil results in premature wear of the transmission.



Main work

- Remove screw cap ① and fill up gear oil.

Gear oil (125 TC EU)	0.70 l (0.74 qt.)	engine oil (15W/50) (☛ p. 100)
Gear oil (250 TC EU)	0.80 l (0.85 qt.)	engine oil (15W/50) (☛ p. 100)

- Mount and tighten the screw cap.



Danger

Danger of poisoning Exhaust gases are toxic and inhaling them may result in unconsciousness and/or death.

- When running the engine, always make sure there is sufficient ventilation, and do not start or run the engine in an enclosed space without an effective exhaust extraction system.

- Start the engine and check that it is oil-tight.

Finishing work

- Check the gear oil level. (☛ p. 81)

16.5 Adding gear oil 🛠️

i Info

Too little gear oil or poor-quality gear oil results in premature wear of the transmission. The gear oil must be added while the engine is cold.

Preparatory work

- Park the motorcycle on a level surface.

**Main work
(125 TC EU)**

- Remove screw ❶ from the opening used to check the gear oil level.



(250 TC EU)

- Remove screw ❶ from the opening used to check the gear oil level.



- Remove screw cap ❷.

- Add gear oil until it emerges from the opening used to check the gear oil level.

engine oil (15W/50) (☛ p. 100)

- Mount and tighten the screw in the opening used to check the gear oil level.

Guideline

(125 TC EU)

Screw, gear oil level check	M6	10 Nm (7.4 lbf ft)
-----------------------------	----	--------------------

(250 TC EU)

Screw, gear oil level check	M6	10 Nm (7.4 lbf ft)
-----------------------------	----	--------------------

- Mount and tighten screw cap ❷.

Finishing work



Danger

Danger of poisoning Exhaust gases are toxic and inhaling them may result in unconsciousness and/or death.

- When running the engine, always make sure there is sufficient ventilation, and do not start or run the engine in an enclosed space without an effective exhaust extraction system.

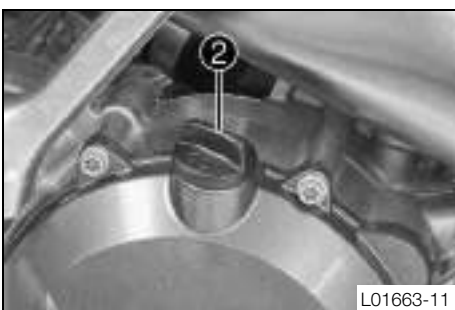

- Start the engine and check that it is oil-tight.

17.1 Cleaning the motorcycle

Note

Material damage Damage and destruction of components by high-pressure cleaning equipment.

- When cleaning the vehicle with a pressure cleaner, do not point the water jet directly onto electrical components, connectors, cables, bearings, etc. Maintain a minimum distance of 60 cm between the nozzle of the pressure cleaner and the component. Excessive pressure can cause malfunctions or destroy these parts.

Warning

Environmental hazard Hazardous substances cause environmental damage.

- Oil, grease, filters, fuel, cleaners, brake fluid, etc., should be disposed of as stipulated in applicable regulations.

Info

If you clean the motorcycle regularly, its value and appearance will be maintained over a long period. Avoid direct sunlight on the motorcycle during cleaning.

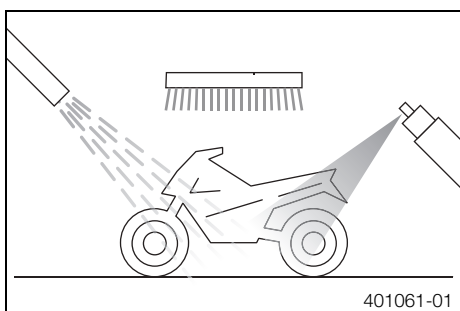

- Close off the exhaust system to prevent water from entering.
- Remove coarse dirt particles by spraying gently with water.
- Spray very dirty areas with a normal motorcycle cleaner and then clean with a soft brush.

Info

Use warm water containing normal motorcycle cleaner and a soft sponge. Never apply motorcycle cleaner to the dry vehicle; always rinse with water first.

- After rinsing the motorcycle with a gentle water spray, allow it to dry thoroughly.
- Empty the carburetor float chamber. (☛ p. 77)
- Remove the plug from the exhaust system.

Warning

Danger of accidents Reduced braking efficiency due to a wet or dirty brake system.

- Clean or dry a dirty or wet brake system by riding and braking gently.

- After cleaning, take a short ride until the engine reaches operating temperature.

Info

The heat produced causes water at inaccessible locations in the engine and brake system to evaporate.

- Push back the protection caps on the handlebar controls to allow water that may have penetrated there to evaporate.
- After the motorcycle has cooled off, lubricate all moving parts and bearings.
- Clean the chain. (☛ p. 47)
- Treat bare metal parts (except for brake discs and exhaust system) with anti-corrosion materials.
- Treat all plastic parts and powder-coated parts with a mild cleaning and care product.

18.1 Storage



Warning

Danger of poisoning Fuel is poisonous and a health hazard.

- Fuel must not come into contact with the skin, eyes, or clothing. Do not breathe in the fuel vapors. If contact occurs with the eyes, rinse with water immediately and contact a physician. Immediately clean contaminated areas on the skin with soap and water. If fuel is swallowed, contact a physician immediately. Change clothing that is contaminated with fuel. Store fuel properly in a suitable canister and keep away from children.



Info

If you want to put the motorcycle into storage for a longer period, take the following actions. Before storing the motorcycle, check all parts for function and wear. If service, repairs or replacements are necessary, you should do this during the storage period (less workshop overload). In this way, you can avoid long workshop waiting times at the start of the new season.

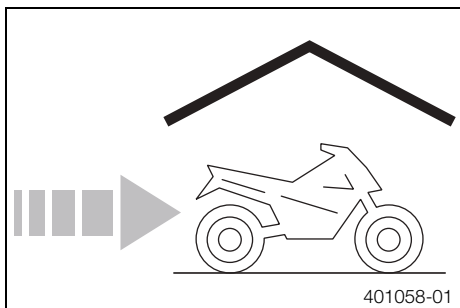

- When refueling for the last time before taking the motorcycle out of service, add fuel additive.
- Refuel. (☛ p. 23)
- Clean the motorcycle. (☛ p. 85)
- Change the gear oil. 🛢️ (☛ p. 81)
- Check the antifreeze and coolant level. (☛ p. 71)
- Empty the carburetor float chamber. 🛢️ (☛ p. 77)
- Check the tire air pressure. (☛ p. 68)
- Store the vehicle in a dry location that is not subject to large fluctuations in temperature.



Info

Husqvarna recommends raising the motorcycle.

- Raise the motorcycle with the lift stand. (☛ p. 33)
- Cover the vehicle with a tarp or cover that is permeable to air.



Info

Do not use non-porous materials since they prevent humidity from escaping, thus causing corrosion.



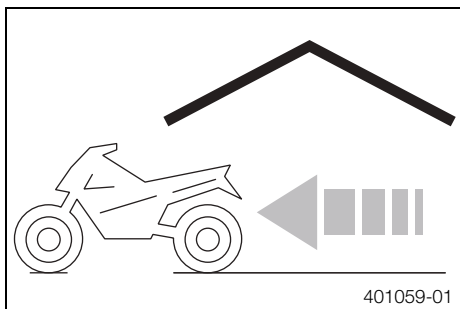

Avoid running the engine for a short time only. Because the engine will not warm up sufficiently, the water vapor produced during combustion will condense, causing engine parts and the exhaust system to rust.

18.2 Preparing for use after storage



- Remove the motorcycle from the lift stand. (☛ p. 33)
- Perform checks and maintenance work when preparing the vehicle for use. (☛ p. 20)
- Make a test ride.

Faults	Possible cause	Action
Engine turns but does not start	Operating error	<ul style="list-style-type: none"> Go through the steps of starting the engine. (☞ p. 20)
	Motorcycle was out of use for a long time and there is old fuel in the float chamber	<ul style="list-style-type: none"> Empty the carburetor float chamber. 🛠️ (☞ p. 77)
	Fuel feed interrupted	<ul style="list-style-type: none"> Check the fuel tank breather. Clean the fuel tap. Check/set the carburetor components.
	Spark plug oily or wet	<ul style="list-style-type: none"> Clean and dry the spark plug, or change it if necessary.
	Electrode distance (plug gap) of spark plug too wide	<ul style="list-style-type: none"> Adjust the plug gap. <p>Guideline</p> <p>(125 TC EU) Spark plug electrode gap 0.60 mm (0.0236 in)</p> <p>(250 TC EU) Spark plug electrode gap 0.60 mm (0.0236 in)</p>
	Fault in ignition system	<ul style="list-style-type: none"> Check the ignition system. 🛠️
	Kill switch cable in wiring harness frayed, kill switch defective	<ul style="list-style-type: none"> Check the kill switch. 🛠️
	The connector or ignition coil is loose or oxidized	<ul style="list-style-type: none"> Clean the connector and treat it with contact spray.
Engine has no idle	Water in carburetor or jets blocked	<ul style="list-style-type: none"> Check/set the carburetor components.
	Idling jet blocked	<ul style="list-style-type: none"> Check/set the carburetor components.
	Adjusting screws on carburetor distorted	<ul style="list-style-type: none"> Carburetor - adjust the idle speed. 🛠️ (☞ p. 76)
	Spark plug defective	<ul style="list-style-type: none"> Change the spark plug.
Engine does not speed up	Ignition system defective	<ul style="list-style-type: none"> Check the ignition coil. 🛠️ Check the spark plug connector. 🛠️
	Carburetor running over because float needle dirty or worn	<ul style="list-style-type: none"> Check/set the carburetor components.
	Loose carburetor jets	<ul style="list-style-type: none"> Check/set the carburetor components.
Engine has too little power	Fault in ignition system	<ul style="list-style-type: none"> Check the ignition system. 🛠️
	Fuel feed interrupted	<ul style="list-style-type: none"> Check the fuel tank breather. Clean the fuel tap. Check/set the carburetor components.
	Air filter very dirty	<ul style="list-style-type: none"> Clean the air filter and air filter box. 🛠️ (☞ p. 43)
	Exhaust system leaky, deformed or too little glass fiber yarn filling in main silencer	<ul style="list-style-type: none"> Check exhaust system for damage. Change the glass fiber yarn filling of the main silencer. 🛠️ (☞ p. 44)
	Diaphragm or reed valve housing damaged	<ul style="list-style-type: none"> Check the diaphragm and reed valve housing.
Engine stalls or is popping into the carburetor	Lack of fuel	<ul style="list-style-type: none"> Turn handle ❶ of the fuel tap to the ON position. (Figure L01808-10 ☞ p. 13) Refuel. (☞ p. 23)
	Engine takes in bad air	<ul style="list-style-type: none"> Check the intake flange and carburetor for tightness.
	The connector or ignition coil is loose or oxidized	<ul style="list-style-type: none"> Clean the connector and treat it with contact spray.
Engine overheats	Too little coolant in cooling system	<ul style="list-style-type: none"> Check the cooling system for leakage. Check the coolant level. (☞ p. 72)
	Too little air stream	<ul style="list-style-type: none"> Switch off engine when stationary.
	Radiator fins very dirty	<ul style="list-style-type: none"> Clean the radiator fins.

Faults	Possible cause	Action
Engine overheats	Foam formation in cooling system	<ul style="list-style-type: none"> - Drain the coolant.  (☞ p. 72) - Refill with coolant.  (☞ p. 73)
	Damaged cylinder head or cylinder head gasket	- Check the cylinder head or cylinder head gasket.
	Bent radiator hose	- Change the radiator hose. 
	Incorrect ignition point due to loose stator	- Adjust the ignition. 
White smoke emission (steam in exhaust gas)	Damaged cylinder head or cylinder head gasket	- Check the cylinder head or cylinder head gasket.
Gear oil exits at the vent hose	Too much gear oil added	- Check the gear oil level. (☞ p. 81)
Water in the gear oil	Damaged shaft seal ring or water pump	- Check the shaft seal ring and water pump.

20.1 Engine

20.1.1 125 TC EU

Design	1-cylinder 2-stroke engine, water-cooled, with reed intake and exhaust control
Displacement	124.8 cm ³ (7.616 cu in)
Stroke	54.5 mm (2.146 in)
Bore	54 mm (2.13 in)
Crankshaft bearing	1 grooved ball bearing/1 roller bearing
Conrod bearing	Needle bearing
Piston pin bearing	Needle bearing
Pistons	Aluminum cast
Piston rings	2 half keystone rings
X (upper edge of piston to upper edge of cylinder)	0... 0.10 mm (0... 0.0039 in)
Z (height of control flap)	43.7 mm (1.72 in)
Primary transmission	23:73
Clutch	Multidisc clutch in oil bath/hydraulically activated
Gearbox	6-gear, claw shifted
Transmission ratio	
1st gear	13:32
2nd gear	15:30
3rd gear	17:28
4th gear	20:28
5th gear	19:23
6th gear	22:24
Ignition	Contactless controlled fully electronic ignition with digital ignition adjustment, type Kokusan
Ignition point (BTDC)	1.4 mm (0.055 in)
Spark plug	NGK BR9 ECMVX
Spark plug electrode gap	0.60 mm (0.0236 in)
Starting aid	Kick starter

20.1.2 250 TC EU

Design	1-cylinder 2-stroke engine, water-cooled, with reed intake and exhaust control
Displacement	249 cm ³ (15.19 cu in)
Stroke	72 mm (2.83 in)
Bore	66.4 mm (2.614 in)
Exhaust valve - Beginning of adjustment	5,600 rpm
Exhaust valve - end of adjustment with red auxiliary spring	7,200 rpm
Exhaust valve - end of adjustment with yellow auxiliary spring	7,900 rpm
Exhaust valve - end of adjustment with green auxiliary spring	8,400 rpm
Crankshaft bearing	1 grooved ball bearing/1 roller bearing
Conrod bearing	Needle bearing
Piston pin bearing	Needle bearing
Pistons	Aluminum cast
Piston rings	2 half keystone rings
X (upper edge of piston to upper edge of cylinder)	0... 0.10 mm (0... 0.0039 in)
Z (height of control flap)	48 mm (1.89 in)
Primary transmission	26:72
Clutch	Multidisc clutch in oil bath/hydraulically activated
Gearbox	5-gear, claw shifted

Transmission ratio	
First gear	14:28
Second gear	15:24
Third gear	18:24
Fourth gear	21:24
Fifth gear	22:21
Ignition	Contactless controlled fully electronic ignition with digital ignition adjustment, type Kokusan
Ignition point (BTDC)	1.9 mm (0.075 in)
Spark plug	NGK BR 8 ECM
Spark plug electrode gap	0.60 mm (0.0236 in)
Starting aid	Kick starter

20.2 Engine tightening torques

20.2.1 125 TC EU

Screw, inner membrane sheets	EJOT DELTA PT[®] 35x25	1 Nm (0.7 lbf ft)	–
Screw, membrane support plate	EJOT DELTA PT[®] 30x12	1 Nm (0.7 lbf ft)	–
Screw, outer membrane sheets	EJOT DELTA PT[®] 30x6	1 Nm (0.7 lbf ft)	–
Locking screw for bearing	M5	6 Nm (4.4 lbf ft)	Loctite[®] 243TM
Screw, alternator cover	M5	5 Nm (3.7 lbf ft)	–
Screw, centrifugal timer	M5	8 Nm (5.9 lbf ft)	Loctite[®] 243TM
Screw, exhaust control cover	M5	5 Nm (3.7 lbf ft)	–
Screw, exhaust flange	M5	6 Nm (4.4 lbf ft)	–
Screw, ignition system/stator	M5	6 Nm (4.4 lbf ft)	Loctite[®] 222TM
Screw, lock washer, axle for control flap	M5	6 Nm (4.4 lbf ft)	Loctite[®] 243TM
Screw, locking lever	M5	6 Nm (4.4 lbf ft)	Loctite[®] 243TM
Screw, water pump wheel	M5	6 Nm (4.4 lbf ft)	Loctite[®] 243TM
Adjustment cable, exhaust control	M6	10 Nm (7.4 lbf ft)	Loctite[®] 243TM
Bleeder screw, cylinder head	M6	10 Nm (7.4 lbf ft)	–
Screw, clutch cover	M6	10 Nm (7.4 lbf ft)	–
Screw, clutch slave cylinder	M6	10 Nm (7.4 lbf ft)	Loctite[®] 243TM
Screw, clutch spring	M6	10 Nm (7.4 lbf ft)	–
Screw, engine case	M6	10 Nm (7.4 lbf ft)	–
Screw, exhaust control	M6	10 Nm (7.4 lbf ft)	–
Screw, gear oil level check	M6	10 Nm (7.4 lbf ft)	–
Screw, intake flange/reed valve housing	M6	10 Nm (7.4 lbf ft)	–
Screw, kick starter stop plate	M6	10 Nm (7.4 lbf ft)	Loctite[®] 243TM
Screw, shift lever	M6	14 Nm (10.3 lbf ft)	Loctite[®] 243TM
Screw, shifting gate	M6	10 Nm (7.4 lbf ft)	Loctite[®] 243TM
Screw, water pump cover	M6	10 Nm (7.4 lbf ft)	Loctite[®] 243TM
Screw, cylinder head	M7	18 Nm (13.3 lbf ft)	–
Axle for control flap, exhaust control	M8	Step 1 3 Nm (2.2 lbf ft) Step 2 (loosen, counter-clockwise) 1/4 turn	–
Nut, cylinder base	M8	30 Nm (22.1 lbf ft)	–
Screw, kick starter	M8	25 Nm (18.4 lbf ft)	Loctite[®] 243TM
Screw, shift drum locating	M8	25 Nm (18.4 lbf ft)	Loctite[®] 243TM
Stud, cylinder base	M8	35 Nm (25.8 lbf ft)	–
Drain plug, water pump cover	M10x1	15 Nm (11.1 lbf ft)	–
Gear oil drain plug	M10x1	15 Nm (11.1 lbf ft)	–

Nut, rotor	M12x1	60 Nm (44.3 lbf ft)	–
Gear oil drain plug with magnet	M12x1.5	20 Nm (14.8 lbf ft)	–
Spark plug	M14x1.25	25 Nm (18.4 lbf ft)	–
Nut, primary gear	M16LHx1.5	130 Nm (95.9 lbf ft)	Loctite® 243™
Nut, inner clutch hub	M18x1.5	130 Nm (95.9 lbf ft)	Loctite® 243™
Cap nut, exhaust control	M26x1	35 Nm (25.8 lbf ft)	–

20.2.2 250 TC EU

Screw, inner membrane sheets	EJOT DELTA PT® 35x25	1 Nm (0.7 lbf ft)	–
Screw, membrane support plate	EJOT DELTA PT® 30x12	1 Nm (0.7 lbf ft)	–
Screw, outer membrane sheets	EJOT DELTA PT® 30x6	1 Nm (0.7 lbf ft)	–
Screw, stator	M5	6 Nm (4.4 lbf ft)	Loctite® 243™
Screw, alternator cover	M5	5 Nm (3.7 lbf ft)	–
Screw, angle lever, exhaust control	M5	6 Nm (4.4 lbf ft)	Loctite® 243™
Screw, clutch spring retainer	M5	6 Nm (4.4 lbf ft)	–
Screw, crankshaft position sensor	M5	6 Nm (4.4 lbf ft)	Loctite® 243™
Screw, exhaust control cap	M5	5 Nm (3.7 lbf ft)	–
Screw, exhaust control cover	M5	6 Nm (4.4 lbf ft)	–
Screw, locking lever	M5	6 Nm (4.4 lbf ft)	Loctite® 243™
Screw, retaining bracket of exhaust control	M5	7 Nm (5.2 lbf ft)	Loctite® 243™
Screw, water pump wheel	M5	6 Nm (4.4 lbf ft)	Loctite® 243™
Screw, bearing retainer	M6	10 Nm (7.4 lbf ft)	Loctite® 243™
Screw, clutch cover	M6	10 Nm (7.4 lbf ft)	–
Screw, control flap, exhaust control	M6	10 Nm (7.4 lbf ft)	Loctite® 243™
Screw, engine case	M6x40	10 Nm (7.4 lbf ft)	–
Screw, engine case	M6x55	10 Nm (7.4 lbf ft)	–
Screw, engine case	M6x60	10 Nm (7.4 lbf ft)	–
Screw, exhaust flange	M6	8 Nm (5.9 lbf ft)	–
Screw, gear oil level check	M6	10 Nm (7.4 lbf ft)	–
Screw, intake flange/reed valve housing	M6	10 Nm (7.4 lbf ft)	–
Screw, intermediate wheel bolt	M6	8 Nm (5.9 lbf ft)	Loctite® 648™
Screw, kick starter spring	M6	10 Nm (7.4 lbf ft)	Loctite® 243™
Screw, kick starter stop plate	M6	10 Nm (7.4 lbf ft)	Loctite® 243™
Screw, shift drum locating	M6	10 Nm (7.4 lbf ft)	Loctite® 243™
Screw, shift lever	M6	14 Nm (10.3 lbf ft)	Loctite® 243™
Screw, slave cylinder of the clutch	M6	10 Nm (7.4 lbf ft)	–
Screw, water pump cover	M6	10 Nm (7.4 lbf ft)	–
Screw, cylinder head	M8	27 Nm (19.9 lbf ft)	–
Screw, kick starter	M8	25 Nm (18.4 lbf ft)	Loctite® 243™
Nut, cylinder base	M10	35 Nm (25.8 lbf ft)	–
Drain plug, water pump cover	M10x1	15 Nm (11.1 lbf ft)	–
Nut, rotor	M12x1	60 Nm (44.3 lbf ft)	–
Gear oil drain plug with magnet	M12x1.5	20 Nm (14.8 lbf ft)	–
Spark plug	M14x1.25	25 Nm (18.4 lbf ft)	–
Nut, inner clutch hub	M18x1.5	120 Nm (88.5 lbf ft)	Loctite® 648™
Nut, primary gear	M18LHx1.5	150 Nm (110.6 lbf ft)	Loctite® 648™

20.3 Capacities

20.3.1 Gear oil

Gear oil (125 TC EU)	0.70 l (0.74 qt.)	engine oil (15W/50) (☛ p. 100)
Gear oil (250 TC EU)	0.80 l (0.85 qt.)	engine oil (15W/50) (☛ p. 100)

20.3.2 Coolant

Coolant	1.2 l (1.3 qt.)	Coolant (☛ p. 100)
		Coolant (mixed ready to use) (☛ p. 100)

20.3.3 Fuel

Total fuel tank capacity, approx.	7.5 l (1.98 US gal)	Super unleaded (98 octane) mixed with 2-stroke engine oil (1:40) (☛ p. 101) (125 TC EU)
		Super unleaded (95 octane) mixed with 2-stroke engine oil (1:60) (☛ p. 101) (250 TC EU)

20.4 Chassis

Frame	Central tube frame made of chrome molybdenum steel tubing	
Fork	WP Suspension Up Side Down 4860 MXMA CC	
Suspension travel		
Front	300 mm (11.81 in)	
Suspension travel		
Rear	317 mm (12.48 in)	
Fork offset (125 TC EU)	22 mm (0.87 in)	
Fork offset (250 TC EU)	20 mm (0.79 in)	
Shock absorber	WP Suspension 5018 BAVP DCC	
Brake system	Disc brakes, brake calipers on floating bearings	
Brake discs - diameter		
Front	260 mm (10.24 in)	
Rear	220 mm (8.66 in)	
Brake discs - wear limit		
Front	2.5 mm (0.098 in)	
Rear	3.5 mm (0.138 in)	
Tire air pressure off road		
Front	1.0 bar (15 psi)	
Rear	1.0 bar (15 psi)	
Secondary ratio (125 TC EU)	13:50	
Secondary ratio (250 TC EU)	13:48	
Chain	5/8 x 1/4"	
Rear sprockets available	48, 50, 52	
Steering head angle	63.5°	
Wheelbase (125 TC EU)	1,480±10 mm (58.27±0.39 in)	
Wheelbase (250 TC EU)	1,495±10 mm (58.86±0.39 in)	
Seat height unloaded	992 mm (39.06 in)	
Ground clearance unloaded (125 TC EU)	395 mm (15.55 in)	
Ground clearance unloaded (250 TC EU)	385 mm (15.16 in)	
Weight without fuel, approx. (125 TC EU)	92.3 kg (203.5 lb.)	
Weight without fuel, approx. (250 TC EU)	97.8 kg (215.6 lb.)	
Maximum permissible front axle load	145 kg (320 lb.)	
Maximum permissible rear axle load	190 kg (419 lb.)	
Maximum permissible overall weight	335 kg (739 lb.)	

20.5 Tires

Validity	Front tires	Rear tires
(125 TC EU)	80/100 - 21 51M TT Dunlop GEOMAX MX51 FA	100/90 - 19 57M TT Dunlop GEOMAX MX51
(250 TC EU)	80/100 - 21 51M TT Dunlop GEOMAX MX51 FA	110/90 - 19 62M TT Dunlop GEOMAX MX51

Additional information is available in the Service section under:
www.husqvarna-motorcycles.com

20.6 Fork

20.6.1 125 TC EU

Fork part number	14.18.7N.51	
Fork	WP Suspension Up Side Down 4860 MXMA CC	
Compression damping		
Comfort	14 clicks	
Standard	12 clicks	
Sport	10 clicks	
Rebound damping		
Comfort	14 clicks	
Standard	12 clicks	
Sport	10 clicks	
Spring length with preload spacer(s)	488 mm (19.21 in)	
Spring rate		
Weight of rider: 65... 75 kg (143... 165 lb.)	4.2 N/mm (24 lb/in)	
Weight of rider: 75... 85 kg (165... 187 lb.)	4.4 N/mm (25.1 lb/in)	
Weight of rider: 85... 95 kg (187... 209 lb.)	4.6 N/mm (26.3 lb/in)	
Gas pressure	1.2 bar (17 psi)	
Fork length	940 mm (37.01 in)	
Oil capacity per cartridge	195 ml (6.59 fl. oz.)	Fork oil (SAE 4) (48601166S1) (☛ p. 100)
Oil capacity fork leg without cartridge	360 ml (12.17 fl. oz.)	Fork oil (SAE 4) (48601166S1) (☛ p. 100)

20.6.2 250 TC EU

Fork part number	14.18.7N.53	
Fork	WP Suspension Up Side Down 4860 MXMA CC	
Compression damping		
Comfort	14 clicks	
Standard	12 clicks	
Sport	10 clicks	
Rebound damping		
Comfort	14 clicks	
Standard	12 clicks	
Sport	10 clicks	
Spring length with preload spacer(s)	488 mm (19.21 in)	
Spring rate		
Weight of rider: 65... 75 kg (143... 165 lb.)	4.4 N/mm (25.1 lb/in)	
Weight of rider: 75... 85 kg (165... 187 lb.)	4.6 N/mm (26.3 lb/in)	
Weight of rider: 85... 95 kg (187... 209 lb.)	4.8 N/mm (27.4 lb/in)	
Gas pressure	1.2 bar (17 psi)	
Fork length	940 mm (37.01 in)	

Oil capacity per cartridge	195 ml (6.59 fl. oz.)	Fork oil (SAE 4) (48601166S1) (☛ p. 100)
Oil capacity fork leg without cartridge	380 ml (12.85 fl. oz.)	Fork oil (SAE 4) (48601166S1) (☛ p. 100)

20.7 Shock absorber

20.7.1 125 TC EU

Shock absorber part number	18.15.7N.51
Shock absorber	WP Suspension 5018 BAVP DCC
Compression damping, low-speed	
Comfort	17 clicks
Standard	15 clicks
Sport	13 clicks
Compression damping, high-speed	
Comfort	2.5 turns
Standard	2 turns
Sport	1.5 turns
Rebound damping	
Comfort	17 clicks
Standard	15 clicks
Sport	13 clicks
Spring preload	12 mm (0.47 in)
Spring rate	
Weight of rider: 65... 75 kg (143... 165 lb.)	45 N/mm (257 lb/in)
Weight of rider: 75... 85 kg (165... 187 lb.)	48 N/mm (274 lb/in)
Weight of rider: 85... 95 kg (187... 209 lb.)	51 N/mm (291 lb/in)
Spring length	260 mm (10.24 in)
Gas pressure	10 bar (145 psi)
Static sag	30 mm (1.18 in)
Riding sag	100 mm (3.94 in)
Fitted length	486 mm (19.13 in)
Shock absorber oil (☛ p. 101)	SAE 2.5

20.7.2 250 TC EU

Shock absorber part number	18.15.7N.53
Shock absorber	WP Suspension 5018 BAVP DCC
Compression damping, low-speed	
Comfort	17 clicks
Standard	15 clicks
Sport	13 clicks
Compression damping, high-speed	
Comfort	2.5 turns
Standard	2 turns
Sport	1.5 turns
Rebound damping	
Comfort	17 clicks
Standard	15 clicks
Sport	13 clicks
Spring preload	12 mm (0.47 in)
Spring rate	
Weight of rider: 65... 75 kg (143... 165 lb.)	51 N/mm (291 lb/in)
Weight of rider: 75... 85 kg (165... 187 lb.)	54 N/mm (308 lb/in)

Weight of rider: 85... 95 kg (187... 209 lb.)	57 N/mm (325 lb/in)
Spring length	260 mm (10.24 in)
Gas pressure	10 bar (145 psi)
Static sag	30 mm (1.18 in)
Riding sag	100 mm (3.94 in)
Fitted length	486 mm (19.13 in)
Shock absorber oil (☛ p. 101)	SAE 2.5

20.8 Chassis tightening torques

Spoke nipple, front wheel	M4.5	5... 6 Nm (3.7... 4.4 lbf ft)	–
Spoke nipple, rear wheel	M4.5	5... 6 Nm (3.7... 4.4 lbf ft)	–
Screw, shock absorber adjusting ring	M5	5 Nm (3.7 lbf ft)	–
Remaining nuts, chassis	M6	10 Nm (7.4 lbf ft)	–
Remaining screws, chassis	M6	10 Nm (7.4 lbf ft)	–
Screw, ball joint of push rod on foot brake cylinder	M6	10 Nm (7.4 lbf ft)	Loctite® 243™
Screw, chain sliding guard	M6	6 Nm (4.4 lbf ft)	Loctite® 243™
Screw, front brake disc	M6	14 Nm (10.3 lbf ft)	Loctite® 243™
Screw, rear brake disc	M6	14 Nm (10.3 lbf ft)	Loctite® 243™
Screw, throttle grip	M6	5 Nm (3.7 lbf ft)	–
Nut, foot brake lever stop	M8	20 Nm (14.8 lbf ft)	–
Nut, rear sprocket screw	M8	35 Nm (25.8 lbf ft)	Loctite® 2701™
Nut, rim lock	M8	12 Nm (8.9 lbf ft)	–
Remaining nuts, chassis	M8	25 Nm (18.4 lbf ft)	–
Remaining screws, chassis	M8	25 Nm (18.4 lbf ft)	–
Screw, bottom triple clamp	M8	12 Nm (8.9 lbf ft)	–
Screw, chain sliding piece	M8	15 Nm (11.1 lbf ft)	–
Screw, engine brace	M8	33 Nm (24.3 lbf ft)	Loctite® 2701™
Screw, fork stub	M8	15 Nm (11.1 lbf ft)	–
Screw, front brake caliper	M8	25 Nm (18.4 lbf ft)	Loctite® 243™
Screw, handlebar clamp	M8	20 Nm (14.8 lbf ft)	–
Screw, side stand attachment	M8	45 Nm (33.2 lbf ft)	Loctite® 2701™
Screw, subframe	M8x20	30 Nm (22.1 lbf ft)	Loctite® 2701™
Screw, subframe	M8x30	30 Nm (22.1 lbf ft)	Loctite® 2701™
Screw, top steering stem	M8	17 Nm (12.5 lbf ft)	Loctite® 243™
Screw, top triple clamp	M8	17 Nm (12.5 lbf ft)	–
Engine bracket screw	M10	60 Nm (44.3 lbf ft)	–
Remaining nuts, chassis	M10	45 Nm (33.2 lbf ft)	–
Remaining screws, chassis	M10	45 Nm (33.2 lbf ft)	–
Screw, bottom shock absorber	M10	60 Nm (44.3 lbf ft)	Loctite® 2701™
Screw, handlebar support	M10	40 Nm (29.5 lbf ft)	Loctite® 243™
Screw, top shock absorber	M10	60 Nm (44.3 lbf ft)	Loctite® 2701™
Nut, frame to linkage lever	M14x1.5	80 Nm (59 lbf ft)	Loctite® 2701™
Nut, linkage lever on swingarm	M14x1.5	80 Nm (59 lbf ft)	–
Nut, linkage lever to angle lever	M14x1.5	80 Nm (59 lbf ft)	–
Nut, swingarm pivot	M16x1.5	100 Nm (73.8 lbf ft)	–
Nut, rear wheel spindle	M20x1.5	80 Nm (59 lbf ft)	–
Screw, top steering head	M20x1.5	12 Nm (8.9 lbf ft)	–
Screw-in nozzles, cooling system	M20x1.5	12 Nm (8.9 lbf ft)	Loctite® 243™
Screw, front wheel spindle	M24x1.5	45 Nm (33.2 lbf ft)	–

20.9 Carburetor

20.9.1 125 TC EU

Carburetor type	KEIHIN PWK 38S AG
Carburetor identification number	BS5_0
Needle position	4th position from top
Jet needle	NOZH (NOZG, NOZI)
Main jet	182 (180, 185)
Idling jet	42 (40, 45)
Starting jet	85
Idle air adjusting screw	
Open	2 turns
Throttle slide	7 with cut-out

20.9.2 Carburetor - basic setting for sandy surfaces (125 TC EU)

Idle air adjusting screw	
Open	1.5 turns
Idling jet	45
Jet needle	NOZG
Needle position	5th position from top
Main jet	200

Info

If the engine is not running smoothly, use a smaller main jet.

20.9.3 250 TC EU

Carburetor type	KEIHIN PWK 36S AG
Carburetor identification number	BS8_0
Needle position	4th position from top
Jet needle	N1EH (N1EG, N1EI)
Main jet	158 (155, 160)
Idling jet	42 (40)
Starting jet	85
Idle air adjusting screw	
Open	2 turns
Throttle slide	6.5 with cut-out

20.9.4 Carburetor - basic setting for sandy surfaces (250 TC EU)

Idle air adjusting screw	
Open	1.5 turns
Idling jet	45
Jet needle	N1EF
Needle position	5th position from top
Main jet	170

Info

If the engine is not running smoothly, use a smaller main jet.

20.10 Carburetor tuning

20.10.1 Carburetor tuning (125 TC EU)

KEIHIN PWK 38S AG							
M/FT ASL ↓	TEMP →	-20°C ... -7°C	-6°C ... 5°C	6°C ... 15°C	16°C ... 24°C	25°C ... 36°C	37°C ... 49°C
		-2°F ... 20°F	19°F ... 41°F	42°F ... 60°F	61°F ... 78°F	79°F ... 98°F	99°F ... 120°F
3.000 m 10,000 ft ↑ 2.301 m 7,501 ft	ASO IJ NDL POS MJ	2 42 NOZ H 4 182	2 42 NOZ I 4 180	2 40 NOZ I 3 180	2,5 40 NOZ J 2 178	2,5 38 NOZ J 1 175	
2.300 m 7,500 ft ↑ 1.501 m 5,001 ft	ASO IJ NDL POS MJ	1,5 42 NOZ G 4 185	2 42 NOZ H 4 182	2 42 NOZ I 4 180	2 40 NOZ I 3 180	2,5 40 NOZ J 2 178	2,5 38 NOZ J 1 175
1.500 m 5,000 ft ↑ 751 m 2,501 ft	ASO IJ NDL POS MJ	1,5 45 NOZ G 4 188	1,5 42 NOZ G 4 185	2 42 NOZ H 4 182	2 42 NOZ I 4 180	2 40 NOZ I 3 180	2,5 40 NOZ J 2 178
750 m 2,500 ft ↑ 301 m 1,001 ft	ASO IJ NDL POS MJ	1,5 45 NOZ G 5 190	1,5 45 NOZ G 4 188	1,5 42 NOZ G 4 185	2 42 NOZ H 4 182	2 42 NOZ I 4 180	2 40 NOZ I 3 180
300 m 1,000 ft ↑ 0 m 0 ft	ASO IJ NDL POS MJ	1 48 NOZ F 5 192	1,5 45 NOZ G 5 190	1,5 45 NOZ G 4 188	1,5 42 NOZ G 4 185	2 42 NOZ H 4 182	2 42 NOZ I 4 180

401762-01

M/FT ASL	Sea level
TEMP	Temperature
ASO	Idle air adjusting screw open
IJ	Idling jet
NDL	Needle
POS	Needle position from above
MJ	Main jet

Info

Not for sandy surfaces

20.10.2 Carburetor tuning (250 TC EU)

KEIHIN PWK 36S AG							
M/FT ASL ↓	TEMP →	-20°C ... -7°C	-6°C ... 5°C	6°C ... 15°C	16°C ... 24°C	25°C ... 36°C	37°C ... 49°C
		-2°F ... 20°F	19°F ... 41°F	42°F ... 60°F	61°F ... 78°F	79°F ... 98°F	99°F ... 120°F
3.000 m 10,000 ft ↑ 2.301 m 7,501 ft	ASO IJ NDL POS MJ	2 42 N1E H 4 158	2 42 N1E H 3 158	2 40 N1E I 3 155	2 40 N1E I 2 155	2,5 38 N1E J 2 152	
2.300 m 7,500 ft ↑ 1.501 m 5,001 ft	ASO IJ NDL POS MJ	2 42 N1E G 4 160	2 42 N1E H 4 158	2 42 N1E H 3 158	2 40 N1E I 3 155	2 40 N1E I 2 155	2,5 38 N1E J 2 152
1.500 m 5,000 ft ↑ 751 m 2,501 ft	ASO IJ NDL POS MJ	2 45 N1E G 4 162	2 42 N1E G 4 160	2 42 N1E H 4 158	2 42 N1E H 3 158	2 40 N1E I 3 155	2 40 N1E I 2 155
750 m 2,500 ft ↑ 301 m 1,001 ft	ASO IJ NDL POS MJ	1,5 45 N1E F 4 165	2 45 N1E G 4 162	2 42 N1E G 4 160	2 42 N1E H 4 158	2 42 N1E H 3 158	2 40 N1E I 3 155
300 m 1,000 ft ↑ 0 m 0 ft	ASO IJ NDL POS MJ	1,5 45 N1E F 5 168	1,5 45 N1E F 4 165	2 45 N1E G 4 162	2 42 N1E G 4 160	2 42 N1E H 4 158	2 42 N1E H 3 158

401764-01

M/FT ASL	Sea level
TEMP	Temperature
ASO	Open idle air adjusting screw
IJ	Idling jet
NDL	Needle
POS	Needle position from above
MJ	Main jet

Info

Not for sandy surfaces

20.10.3 General carburetor tuning 🐦

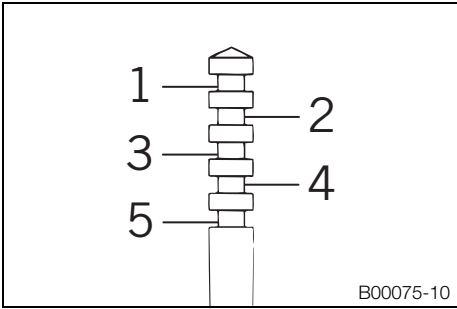

1... 5	Needle position from top
--------	--------------------------

The five possible needle positions are shown here.
The carburetor tuning depends on the defined ambient and operating conditions.

Brake fluid DOT 4 / DOT 5.1

Standard/classification

- DOT

Guideline

- Use only brake fluid that complies with the specified standard (see specifications on the container) and that possesses the corresponding properties.

Coolant

Guideline

- Use only suitable coolant (even in countries with high temperatures). Using inferior antifreeze can result in corrosion and foaming.
- Use only coolant based on ethylene glycol.

Mixture ratio

Antifreeze protection: -25... -45 °C (-13... -49 °F)	50 % corrosion inhibitor/antifreeze 50 % distilled water
------------------------------------------------------	-------------------------------------------------------------

Coolant (mixed ready to use)

Guideline

- Use only coolant based on ethylene glycol.

Antifreeze protection	-40 °C (-40 °F)
-----------------------	-----------------

engine oil (15W/50)

Standard/classification

- JASO T903 MA (☛ p. 103)
- SAE (☛ p. 103) (15W/50)

Guideline

- Use only engine oils that comply with the specified standards (see specifications on the container) and that possess the corresponding properties.

Engine oil, 2-stroke

Standard/classification

- JASO FC (☛ p. 103)

Guideline

- Only use high grade 2-stroke engine oil of a reputable brand.

Fully synthetic

Fork oil (SAE 4) (48601166S1)

Standard/classification

- SAE (☛ p. 103) (SAE 4)

Guideline

- Use only oils that comply with the specified standards (see specifications on the container) and that possess the corresponding properties.

Hydraulic oil (15)

Standard/classification

- ISO VG (15)

Guideline

- Use only hydraulic oil that complies with the specified standard (see specifications on the container) and that possesses the corresponding properties.

Shock absorber oil (SAE 2.5) (50180342S1)

Standard/classification

- SAE (☛ p. 103) (SAE 2.5)

Guideline

- Use only oils that comply with the specified standards (see specifications on the container) and that possess the corresponding properties.

Super unleaded (ROZ 98 / RON 98 / PON 94)

Standard/classification

- DIN EN 228 (ROZ 98 / RON 98 / PON 94)

Super unleaded (ROZ 95/RON 95/PON 91)

Standard/classification

- DIN EN 228 (ROZ 95/RON 95/PON 91)

Guideline

- Only use unleaded super fuel that matches or is equivalent to the specified fuel grade.
- Fuel with an ethanol content of up to 10 % (E10 fuel) is safe to use.



Info

Do **not** use fuel containing methanol (e. g. M15, M85, M100) or more than 10 % ethanol (e. g. E15, E25, E85, E100).

Super unleaded (95 octane) mixed with 2-stroke engine oil (1:60)

Standard/classification

- DIN EN 228
- JASO FC (☛ p. 103) (1:60)

Mixture ratio

1:60	Engine oil, 2-stroke (☛ p. 100) Super unleaded (ROZ 95/RON 95/PON 91) (☛ p. 101)
------	-------------------------------------------------------------------------------------

Super unleaded (98 octane) mixed with 2-stroke engine oil (1:40)

Standard/classification

- DIN EN 228
- JASO FC (☛ p. 103) (1:40)

Mixture ratio

1:40	Engine oil, 2-stroke (☛ p. 100) Super unleaded (ROZ 98 / RON 98 / PON 94) (☛ p. 101)
------	-----------------------------------------------------------------------------------------

High viscosity grease

Recommended supplier

SKF®

- LGHB 2

Rubber grip adhesive (00062030051)

Recommended supplier

KTM-Sportmotorcycle AG

- GRIP GLUE

JASO T903 MA

Different technical development directions required a new specification for 4-stroke motorcycles – the JASO T903 MA Standard. Earlier, engine oils from the automobile industry were used for 4-stroke motorcycles because there was no separate motorcycle specification. Whereas long service intervals are demanded for automobile engines, high performance at high engine speeds are in the foreground for motorcycle engines. In most motorcycles, the gearbox and the clutch are lubricated with the same oil as the engine. The JASO MA Standard meets these special requirements.

SAE

The SAE viscosity classes were defined by the Society of Automotive Engineers and are used for classifying oils according to their viscosity. The viscosity describes only one property of oil and says nothing about quality.

JASO FC

JASO FC is a classification for a 2-stroke engine oil that was specifically developed for the extreme demands of racing. Thanks to first rate synthetic esters and specially designed additives, superb combustion is achieved even under extreme operating conditions.

A

Accessories 7

Air filter

- cleaning 43
- installing 43
- removing 42

Air filter box

- cleaning 43
- sealing 44

Air filter box lid

- installing 42
- removing 42

Antifreeze

- checking 71

Auxiliary substances 7

B

Basic chassis setting

- checking with rider's weight 26

Brake discs

- checking 56

Brake fluid

- front brake, adding 57
- rear brake, adding 61

Brake fluid level

- front brake, checking 57
- rear brake, checking 61

Brake linings

- front brake, changing 58
- front brake, checking 58
- rear brake, changing 62
- rear brake, checking 62

C

Capacity

- coolant 73, 92
- gear oil 82, 92

Carburetor 76

- float chamber, emptying 77
- idle speed, adjusting 76

Chain

- checking 49
- cleaning 47

Chain guide

- checking 49

Chain tension

- adjusting 48
- checking 48

Chassis number 10

Choke 13

Clutch

- fluid level, checking/correcting 53
- fluid, changing 54

Clutch lever 11

- basic position, adjusting 52

Compression damping

- fork, adjusting 31

Compression damping, high-speed

- shock absorber, adjusting 27

Compression damping, low-speed

- shock absorber, adjusting 26

Coolant

- draining 72
- refilling 73

Coolant level

- checking 71-72

Cooling system 70

Customer service 7

D

Difficult operating conditions

- dry sand 16
- high temperatures 18
- low temperatures 19
- muddy surfaces 18
- riding at low speeds 18
- snow 19
- wet sand 17
- wet surfaces 18

Difficult riding conditions 16

E

Engine

- running in 16

Engine characteristic

- auxiliary spring 79
- auxiliary spring, setting 79

Engine number 10

Engine sprocket

- checking 49

Environment 6

F

Figures 7

Filler cap

- closing 12
- opening 12

Filling up

- fuel 23

Foot brake lever 14

- basic position, adjusting 60
- free travel, checking 60

Fork

- basic setting, checking 30

Fork legs

- bleeding 33
- dust boots, cleaning 33
- installing 35
- removing 34

Fork part number 10

Fork protector	
installing	36
removing	35
Frame	
checking	51
Front fender	
installing	40
removing	40
Front wheel	
installing	65
removing	65
Fuel tank	
installing	46
removing	45
Fuel tap	13
G	
Gear oil	
adding	83
changing	81
draining	82
refilling	82
Gear oil level	
checking	81
H	
Hand brake lever	11
basic position, adjusting	56
free travel, checking	56
Handlebar position	32
adjusting	32
I	
Ignition curve	
changing	78
Ignition timing map	
plug-in connection	78
Implied warranty	7
Intended use	5
K	
Kick starter	14
Kill switch	11
L	
Lower triple clamp	
installing	37
removing	36
M	
Main silencer	
glass fiber yarn filling, changing	44
installing	44
removing	44
Map-Select switch	12
Motorcycle	
cleaning	85
raising with lift stand	33
removing from lift stand	33

O	
Operating substances	7
Owner's Manual	6
P	
Plug-in stand	14
Preparing for use	
advice on first use	15
after storage	86
checks and maintenance work when preparing for use	20
Protective clothing	6
R	
Radiator cover	70
installing	70
removing	71
Rear sprocket	
checking	49
Rear wheel	
installing	67
removing	66
Rebound damping	
fork, adjusting	31
shock absorber, adjusting	27
Riding sag	
adjusting	30
Right side cover	
installing	45
removing	45
Rubber grip	
checking	52
securing	52
S	
Safe operation	5
Seat	
mounting	42
removing	42
Service	7
Shift lever	13
basic position, adjusting	79
basic position, checking	78
Shock absorber	
compression damping, general information	26
installing	41
removing	41
riding sag, checking	29
spring preload, adjusting	29
static sag, checking	28
Shock absorber part number	10
Spare parts	7
Spoke tension	
checking	68
Start number plate	
installing	40
removing	39

Starting	20
Steering head bearing	
greasing	39
Steering head bearing play	
adjusting	39
checking	38
Storage	86
Swingarm	
checking	51
T	
Technical data	
capacities	92
carburetor	96
carburetor tuning	97
chassis	92
chassis tightening torques	95
engine	89
engine tightening torques	90
fork	93
shock absorber	94
tires	93
Throttle cable play	
adjusting	75
checking	75
Throttle cable routing	
checking	51
Throttle grip	11
Tire air pressure	
checking	68
Tire condition	
checking	67
Transport	22
Troubleshooting	87-88
Type label	10
U	
Use definition	5
V	
View of vehicle	
front left side	8
rear right	9
W	
Warranty	7
Work rules	6

THE PIONEERS OF MOTOCROSS



3402001en

11/2013



Husqvarna Motorcycles GmbH
Stallhofnerstraße 3 | 5230 Mattighofen
Austria



Photo:
Mitterbauer/Husqvarna
Motorcycles GmbH