

HYOSUNG

HYOSUNG

Aquila 250

Aquila 250

HYOSUNG MOTORS & MACHINERY INC.

SERVICE MANUAL

SERVICE MANUAL

99000-95310

FOREWORD

*This manual contains an introductory description on HYOSUNG *Aquila 250* and procedures for its inspection /service and overhaul of its main components.*

Other information considered as generally known is not included.

Read GENERAL INFORMATION section to familiarize yourself with outline of the vehicle and MAINTENANCE and other sections to use as a guide for proper inspection and service.

This manual will help you know the vehicle better so that you can assure your customers of your optimum and quick service.

- ❖ *This manual has been prepared on the basis of the latest specification at the time of publication. If modification has been made since then, difference may exist between the content of this manual and the actual vehicle.*
- ❖ *Illustrations in this manual are used to show the basic principles of operation and work procedures. They may not represent the actual vehicle exactly in detail.*
- ❖ *This manual is intended for those who have enough knowledge and skills for servicing HYOSUNG vehicles. Without such knowledge and skills, you should not attempt servicing by relying on this manual only. Instead, please contact your nearby authorized HYOSUNG motorcycle dealer.*

GROUP INDEX

GENERAL INFORMATION

1

PERIODIC MAINTENANCE

2

ENGINE

3

FUEL SYSTEM

4

ELECTRICAL SYSTEM

5

CHASSIS

6

SERVICING INFORMATION

7

HYOSUNG MOTORS & MACHINERY INC.

Overseas Technical Department

HOW TO USE THIS MANUAL

TO LOCATE WHAT YOU ARE LOOKING FOR:

1. The text of this manual is divided into sections.
2. As the title of these sections are listed on the previous page as GROUP INDEX, select the section where you are looking for.
3. Holding the manual as shown at the right will allow you to find the first page of the section easily.
4. On the first page of each section, its contents are listed. Find the item and page you need.

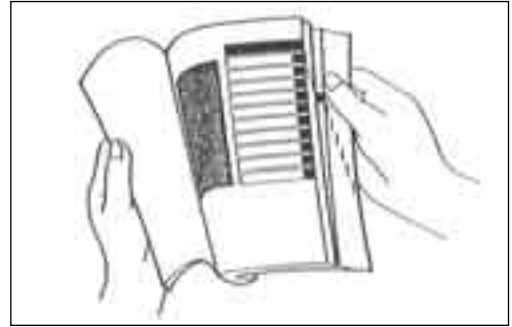





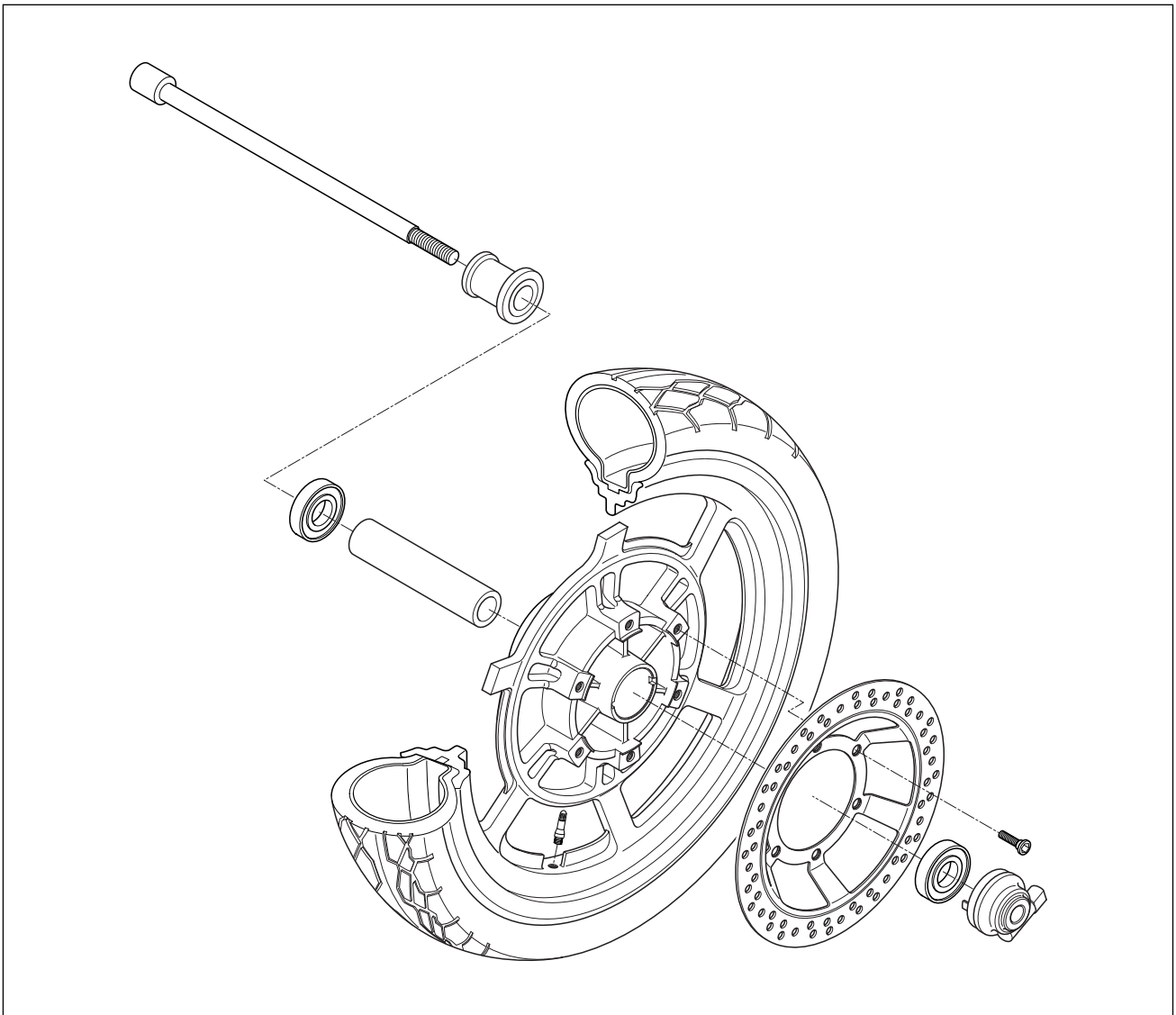







COMPONENT PARTS

Example: Front wheel



SYMBOL

Listed in the table below are the symbols indicating instructions and other information necessary for servicing and meaning associated with them respectively.

SYMBOL	DEFINITION	SYMBOL	DEFINITION
	Torque control required. Data beside it indicates specified torque.		Apply THREAD LOCK "1324".
	Apply oil. Use engine oil unless otherwise specified.		Apply or use brake fluid.
	Apply SUPER GREASE "A".		Measure in voltage range.
	Apply SUPER GREASE "C".		Measure in resistance range.
	Apply SILICONE GREASE.		Measure in current range.
	Apply MOLY PASTE.		Use special tool.
	Apply BOND "1215".		

GENERAL INFORMATION

CONTENTS

INFORMATION LABELS	1-1
GENERAL PRECAUTIONS	1-1
SERIAL NUMBER LOCATION	1-4
FUEL AND OIL RECOMMENDATIONS	1-5
BREAK-IN PROCEDURES	1-6
CYLINDER CLASSIFICATION	1-6
EXTERIOR ILLUSTRATION	1-7
SPECIFICATIONS	1-8

WARNING / CAUTION / NOTE

Please read this manual and follow its instructions carefully. To emphasize special information, the symbol and the words WARNING, CAUTION and NOTE have special meanings. Pay special attention to the messages highlighted by these signal words.

WARNING

Indicates a potential hazard that could result in death or injury.

CAUTION

Indicates a potential hazard that could result in vehicle damage.

NOTE:

Indicates special information to make maintenance easier or instructions cleaner.

Please note, however, that the warning and cautions contained in this manual cannot possibly cover all potential hazards relating to the servicing, or lack of servicing, of the motorcycle. In addition to the WARNING and CAUTION stated, you must use good judgement and basic mechanical safety principles. If you are unsure about how to perform a particular service operation, ask a more experienced mechanic for advice.

GENERAL PRECAUTIONS

WARNING

- ❖ Proper service and repair procedures are important for the safety of the service machanic and the safety and reliability of the vehicle.
- ❖ When 2 or more persons work together, pay attention to the safety of each other.
- ❖ When it is necessary to run the engine indoors, make sure that exhaust gas is forced outdoors.
- ❖ When working with toxic or flammable materials, make sure that the area you work in is well-ventilated and that you follow all off the material manufacturer' s instructions.
- ❖ Never use gasoline as a cleaning solvent.
- ❖ To avoid getting burned, do not touch the engine, engine oil or exhaust system during or for a while after engine operation.
- ❖ After servicing fuel, oil, exhaust or brake systems, check all lines and fittings related to the system for leaks.

⚠ CAUTION

- ❖ If parts replacement is necessary, replace the parts with HYOSUNG Genuine Parts or their equivalent.
- ❖ When removing parts that are to be reused, keep them arranged in an orderly manner so that they may be reinstalled in the proper order and orientation.
- ❖ Be sure to use special tools when instructed.
- ❖ Make sure that all parts used in reassembly are clean, and also lubricated when specified.
- ❖ When use of a certain type of lubricant, bond, or sealant is specified, be sure to use the specified type.
- ❖ When removing the battery, disconnect the negative cable first and then positive cable. When reconnecting the battery, connect the positive cable first and then negative cable, and replace the terminal cover on the positive terminal.
- ❖ When performing service to electrical parts, if the service procedures do not require use of battery power, disconnect the negative cable at the battery.
- ❖ Tighten cylinder head and case bolts and nuts, beginning with larger diameter and ending with smaller diameter, from inside to outside diagonally, to the specified tightening torque.
- ❖ Whenever you remove oil seals, gaskets, packing, O-rings, locking washers, cotter pins, circlips, and certain other parts as specified, be sure to replace them with new ones. Also, before installing these new parts, be sure to remove any left over material from the mating surfaces.
- ❖ Never reuse a circlip. When installing a new circlip, take care not to expand the end gap larger than required to slip the circlip over the shaft. After installing a circlip, always ensure that it is completely seated in its groove and securely fitted.
- ❖ Do not use self-locking nuts a few times over.
- ❖ Use a torque wrench to tighten fasteners to the torque values when specified. Wipe off grease or oil if a thread is smeared with them.
- ❖ After reassembly, check parts for tightness and operation.

- ❖ To protect environment, do not unlawfully dispose of used motor oil and other fluids: batteries, and tires.
- ❖ To protect Earth's natural resources, properly dispose of used vehicles and parts.

HYOSUNG *Aquila 250*



NOTE:

Difference between photographs and actual motorcycles depends on the markets.

SERIAL NUMBER LOCATION

The frame serial number or V.I.N. (Vehicle Identification Number) is stamped on the steering head tube. The engine serial number is located on the left upside of crankcase assembly.

These numbers are required especially for registering the machine and ordering spare parts.

⦿ FRAME SERIAL NUMBER

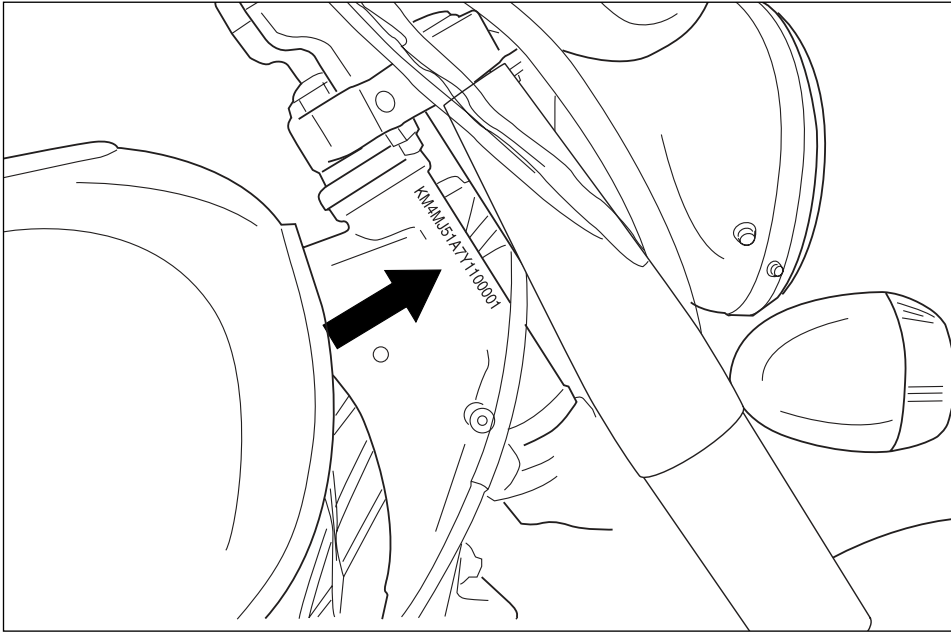

⦿ ENGINE SERIAL NUMBER

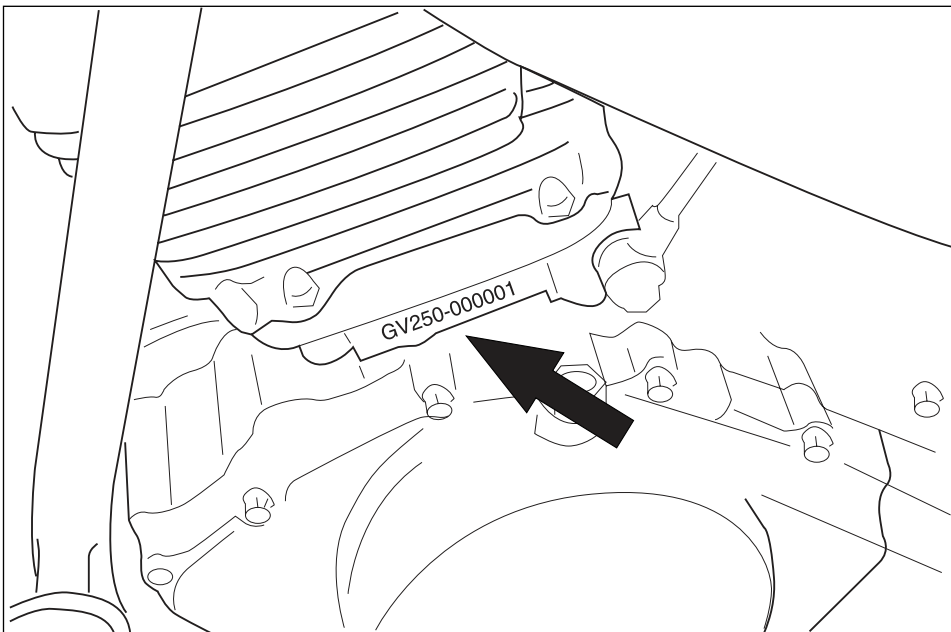

FUEL AND OIL RECOMMENDATION

⦿ FUEL

Gasoline used should be graded 91 octane (Research Method) or higher. An unleaded gasoline type is recommended.

⦿ ENGINE OIL

■ ENGINE OIL SPECIFICATION

Classification system	Grade
API	SF or SG
SAE	10W-40

* *If an SAE 10W-40 motor oil is not available, select an alternative according to the following chart.*

Use a premium quality 4-stroke motor oil to ensure longer service life of your motorcycle.

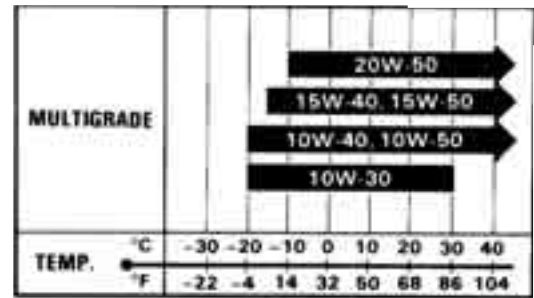

⚠ WARNING

- ❖ Don't mix the unrecommended oil. It could damage the engine.
- ❖ When refilling the oil tank, don't allow the dust to get inside.
- ❖ Mop the oil spilt.
- ❖ Don't put the patch on the cap. It could disturb the oil to be provided and damage the engine.

⦿ BRAKE FLUID

Specification and classification: DOT3 or DOT4

⚠ WARNING

Since the brake system of this motorcycle is filled with a glycol-based brake fluid by the manufacturer, do not use or mix different types of fluid such as silicone-based and petroleum-based fluid for refilling the system, otherwise serious damage will result.

Do not use any brake fluid taken from old or used or unsealed containers.

Never re-use brake fluid left over from a previous servicing, which has been stored for a long period.

⦿ FRONT FORK OIL

Use fork oil : TELLUS #22

BREAK-IN PROCEDURES

During manufacture only the best possible materials are used and all machined parts are finished to a very high standard but it is still necessary to allow the moving parts to “BREAK-IN” before subjecting the engine to maximum stresses. The future performance and reliability of the engine depends on the care and restraint exercised during its early life. The general rules are as follows:

- Keep to these break-in procedures:

Initial 800km	Less than 1/2 throttle
Up to 1,600km	Less than 3/4 throttle

- Upon reaching an odometer reading of 1,600 km you can subject the motorcycle to full throttle operation.
- Do not maintain constant engine speed for an extended period during any portion of the break-in. Try to vary the throttle position.

CYLINDER CLASSIFICATION

The engine of *Aquila 250* is composed of the two cylinder, is classified into the front cylinder and rear cylinder as basis of the motorcycle ahead.

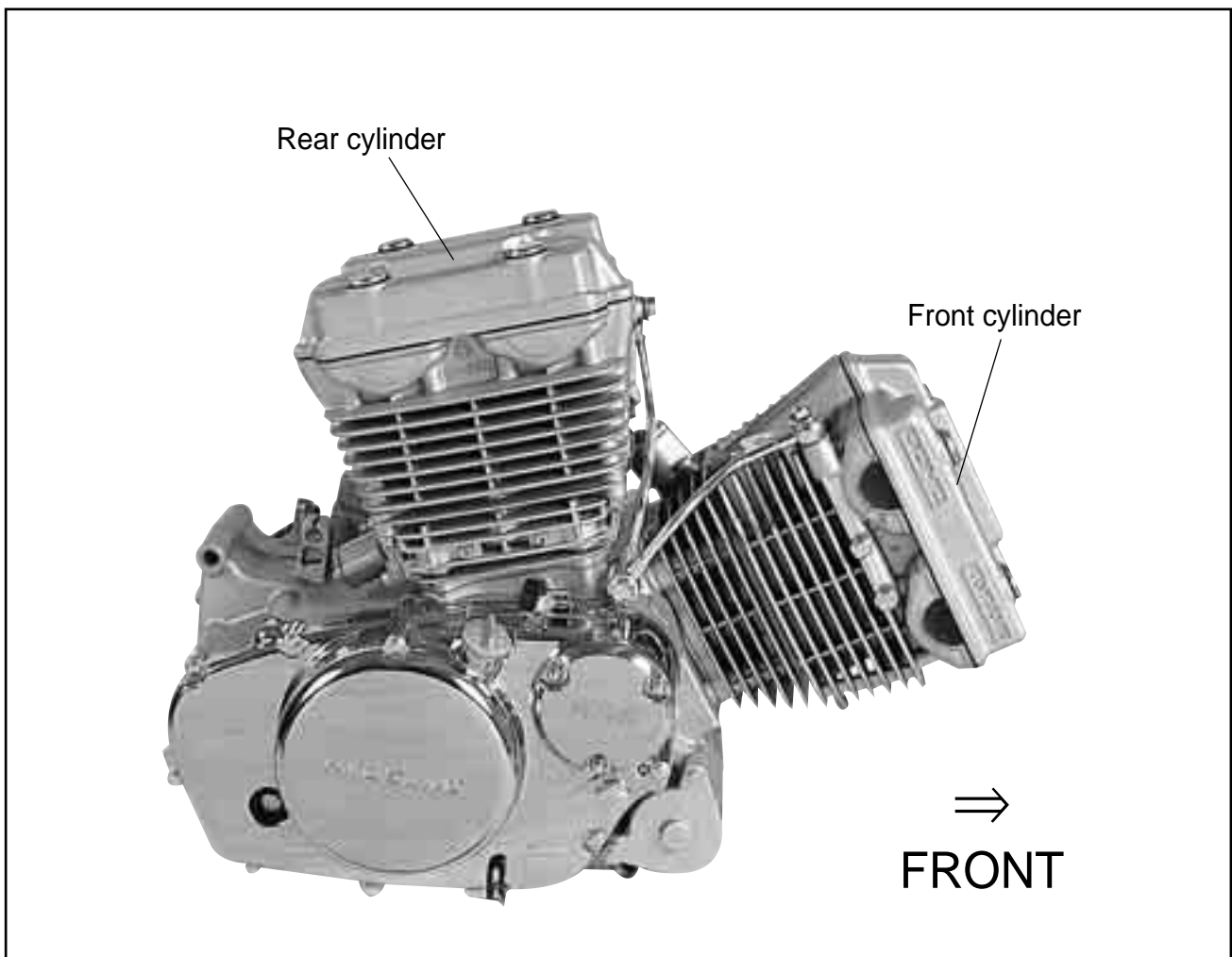

1-7 GENERAL INFORMATION

EXTERIOR ILLUSTRATION

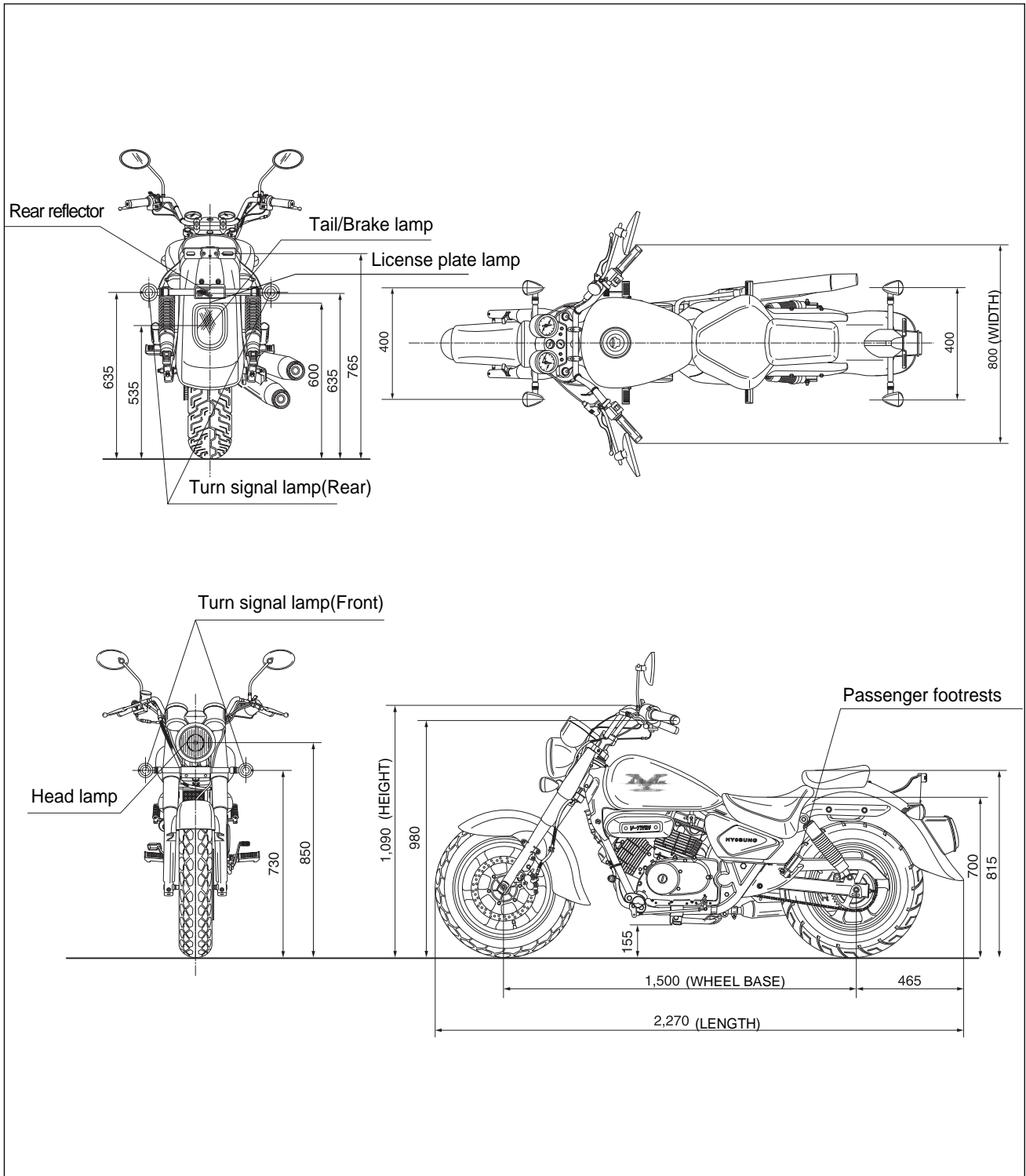

SPECIFICATIONS

DIMENSIONS AND DRY MASS

Overall length	2,270 mm
Overall width	800 mm
Overall height	1,090 mm
Wheelbase	1,500 mm
Ground clearance	155 mm
Unladen mass	155 kg

ENGINE

Type	Four-stroke, DOHC, air-cooled and oil-cooled
Number of cylinder	2
Bore	57.0 mm
Stroke	48.8 mm
Piston displacement	249cm ³
Carburetor	BDS 26TYPE (DOUBLE)
Starter system	Electric starter
Lubrication system	Wet sump

TRANSMISSION

Clutch	Wet multi-plate type
Transmission	5-speed constant mesh
Gearshift pattern	1-down, 4-up
Final reduction	3.290
Gear ratio, 1st	2.460
2nd	1.560
3rd	1.190
4th	0.960
5th	0.840
Drive chain	RK-520DS 116 links

CHASSIS

Front suspension	Telescopic type
Rear suspension	Swingarm type
Steering angle	40 ° (right & left)
Caster	33 °
Trail	135 mm
Front brake	Disk brake
Rear brake	Drum brake
Front tire size	110/90-16 59S
Rear tire size	150/80-15M/C 70S
Front fork stroke	120 mm

1-9 GENERAL INFORMATION

ELECTRICAL

Ignition type	Battery Ignition (CDI)
Ignition timing	13 ° B.T.D.C.at 2,000 rpm and 30 ° B.T.D.C.at 6,000 rpm
Spark plug	CR8E
Battery	12V 6Ah
Fuse	15 A
Head lamp	HI : 35W LO : 35W
Position lamp	5W
Turn signal lamp	10 W
Brake / Tail lamp	21 / 5 W
Speedometer lamp	1.7 W×3
High beam indicator lamp	1.7 W
Turn signal indicator lamp(right & left)	1.7 W×2
License plate lamp	5 W
Neutral indicator lamp	1.7 W

CAPACITIES

Fuel tank	14.0 ℓ
Engine oil, oil change	1,450 ml
with filter change	1,500 ml
overhaul	1,800 ml
Front fork oil (One side)	250 cc

NOTE:

The specifications are subject to change without notice.

PERIODIC MAINTENANCE

CONTENTS

PERIODIC MAINTENANCE SCHEDULE	2- 1
PERIODIC MAINTENANCE CHART	2- 1
LUBRICATION POINTS	2- 2
MAINTENANCE PROCEDURES	2- 3
VALVE CLEARANCE	2- 3
SPARK PLUG	2- 5
EXHAUST PIPE NUTS AND MUFFLER MOUNTING BOLTS	2- 6
AIR CLEANER	2- 6
CARBURETOR	2- 8
FUEL HOSE	2- 8
CLUTCH	2- 9
ENGINE OIL	2- 9
ENGINE OIL FILTER	2-11
DRIVE CHAIN	2-12
BRAKE SYSTEM	2-14
STEERING	2-18
FRONT FORK	2-18
REAR SUSPENSION	2-18
TIRE	2-19
CHASSIS BOLTS AND NUTS	2-19
COMPRESSION PRESSURE	2-20
OIL PRESSURE	2-21

2-1 PERIODIC MAINTENANCE

PERIODIC MAINTENANCE SCHEDULE

The chart below lists the recommended intervals for all the required periodic service work necessary to keep the motorcycle operating at peak performance and economy.

⚠ CAUTION

More frequent servicing should be performed on motorcycles that are used under severe conditions.

PERIODIC MAINTENANCE CHART

⊙ ENGINE

Item \ Interval	Initial 1,000 km	Every 4,000 km	Every 8,000 km	page
Air cleaner element	Clean every 3,000 km · Replace every 12,000 km			2- 6
Exhaust pipe nuts and muffler mounting bolts	Tighten	Tighten	—	2- 6
Valve clearance adjust	Inspect	Inspect	—	2- 3
Spark plug	Clean	Clean	Replace	2- 5
Fuel hose	Inspect	Inspect	—	2- 8
	Replace every 4 years			
Engine oil filter	Replace	Replace	—	2-11
Engine oil	Replace	Replace	—	2- 9
Throttle cable	Inspect	Inspect	—	2- 8
Idle speed	Inspect	Inspect	—	2- 8
Clutch	Inspect	Inspect	—	2- 9

⊙ CHASSIS

Item \ Interval	Initial 1,000 km	Every 4,000 km	Every 8,000 km	page
Drive chain	Clean and lubricate every 1,000km			2-12
Brake	Inspect	Inspect	—	2-14
Brake hose	Inspect	Inspect	—	2-14
	Replace every 4 years			
Brake fluid	Inspect	Inspect	—	2-14
	Replace every 2 years			
Tires	Inspect	Inspect	—	2-19
Steering	Inspect	Inspect	—	2-18
Front forks	—	Inspect	—	2-18
Rear suspension	—	Inspect	—	2-18
Chassis bolts and nuts	Tighten	Tighten	—	2-19

⚠ CAUTION

Using poor quality replacement parts can cause your motorcycle to wear more quickly and shorten its useful life. Use only genuine Hyoung replacement parts or their equivalent.

LUBRICATION POINT

Proper lubrication is important for smooth operation and long life of each working part of the motorcycle. Major lubrication points are indicated below.

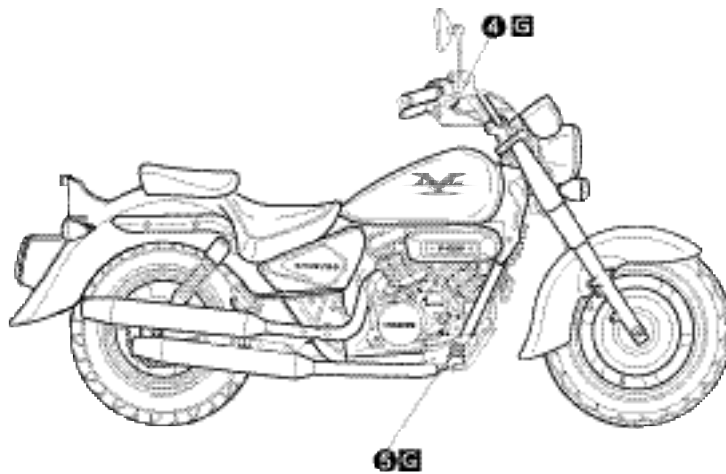
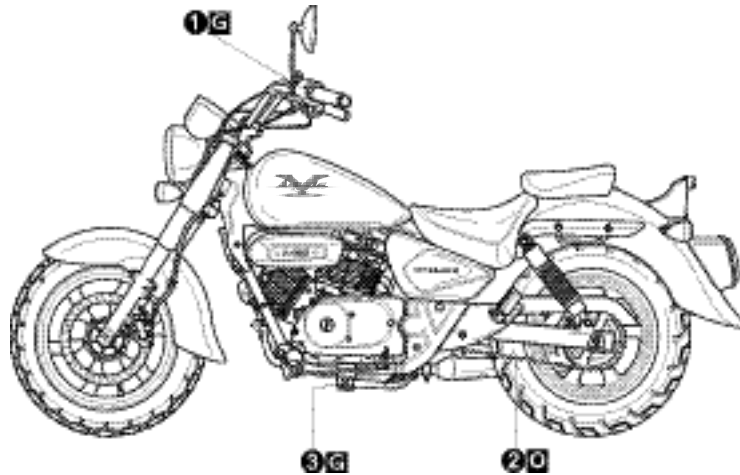

- ① Clutch lever holder
- ② Drive chain
- ③ Side stand pivot and spring hook

- ④ Brake lever holder
- ⑤ Brake pedal pivot

⓪ - Motor oil, Ⓜ - Grease

NOTE:

- ❖ Before lubricating each part, clean off any rusty spots and wipe off any grease, oil, dirt or grime.
- ❖ Lubricate exposed parts which are subject to rust, with either motor oil or grease whenever the motorcycle has been operated under wet or rainy condition.

MAINTENANCE PROCEDURE

This section describes the service procedure for each section of the periodic maintenance.

VALVE CLEARANCE

NOTE:

Inspect Initial 1,000 km and Every 4,000 km.

⚠ CAUTION

The clearance specification is for COLD state.

The valve clearance specification is different for intake and exhaust valves.

Valve clearance adjustment must be checked and adjusted, 1) at the time of periodic inspection, 2) when the valve mechanism is serviced, and 3) when the camshaft is disturbed by removing it for servicing.

- Remove the spark plug. (Refer to page 2-5)
- Remove the right air cleaner box.
- Remove the fuel tank. (Refer to page 4-1)

- Remove the cylinder head cover ① and ②.

- Remove the magneto cover plug ③ and the timing inspection plug ④.

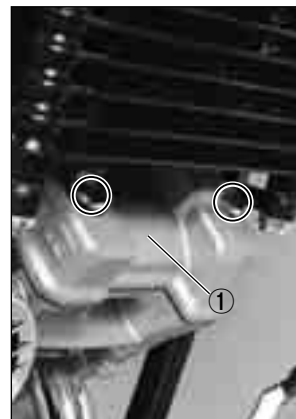
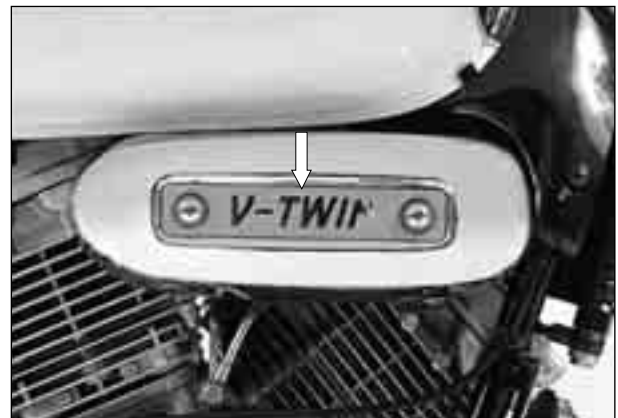

[Front Cylinder]

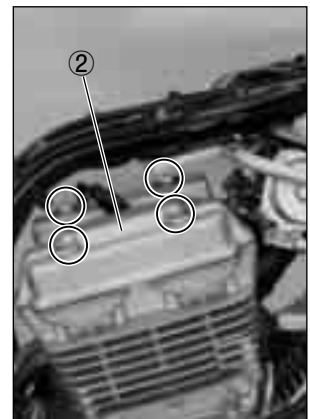

[Rear Cylinder]

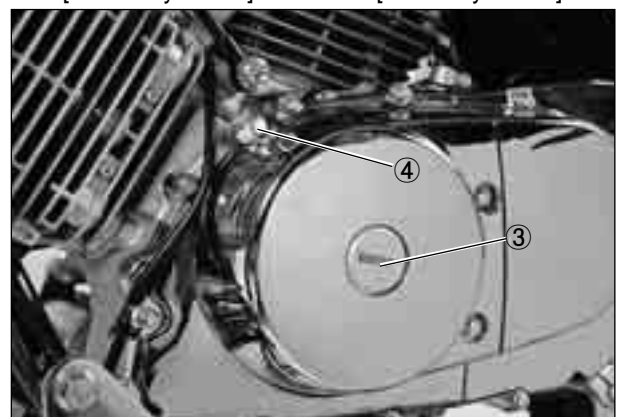

- Rotate the magneto rotor to set the front cylinder's piston at TDC (Top Dead Center) of the compression stroke.
(Rotate the rotor until "F" line on the rotor is aligned with the center of hole on the crankcase.)
- To inspect the front cylinder's valve clearance, insert the thickness gauge to the clearance between the camshaft and the tappet.

Valve clearance (when cold)	
IN.	0.1 ~ 0.2 mm
EX.	0.2 ~ 0.3 mm

 **Thickness gauge : 09900-20806**

- If the clearance is out of specification, first remove the cam chain tensioner, camshaft housing, camshaft.
To install the tappet shim at original position, record the shim NO. and clearance with "A", "B", "C", "D" mark on the cylinder head as the illustration.

Select the tappet that agree with tappet clearance (vertical line) and shim NO.(horizontal line) as refer to the tappet shim selection chart. (Refer to page 7-25 · 26)

Adjust valve timing, install the camshaft housing and the tensioner.

After the crankshaft rotate about 10 times, measure the valve clearance.

If the clearance be not agree, adjust the standard clearance as the same manner above.

- In case that valve adjustment which there is no the tappet shim selection chart, please follow instructions of example in the below.

For example, the intake clearance is 0.4 and the shim is 170 (1.70 mm), select 195 (1.95 mm) of the shim which 170 (1.70 mm) of the shim add up the excess clearance 0.25 mm when adjust with the standard 0.15 as the intake standard clearance 0.1 ~ 0.2 mm.

CAUTION

- ❖ Valve clearance should be checked when the engine is cold.
- ❖ If you don't rotate the crankshaft about 10 times before measuring the valve clearance, there is no meaning of valve clearance.

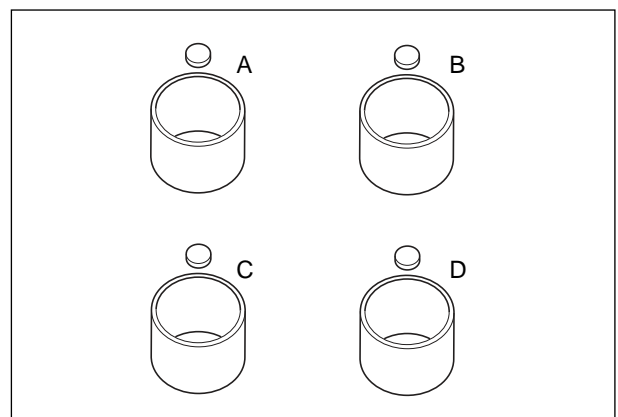
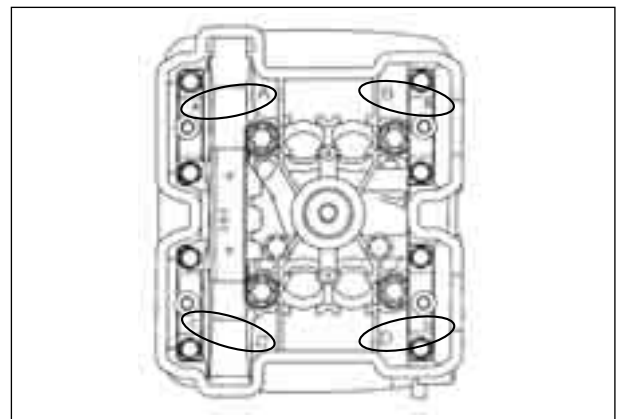
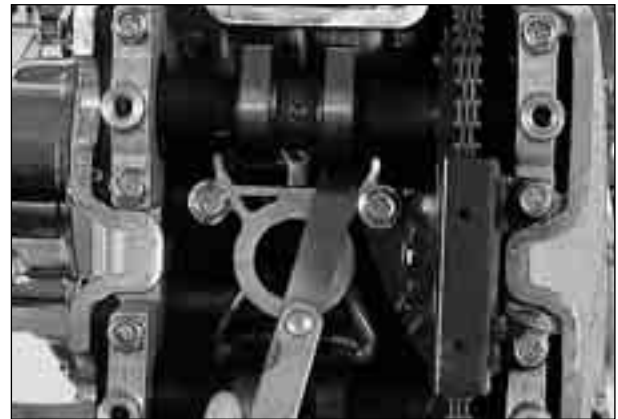

2-5 PERIODIC MAINTENANCE

- Rotate the magneto rotor to set the rear cylinder's piston at TDC(Top Dead Center) of the compression stroke.
(Rotate the rotor 285° counter-clockwise from the "F" line, and until the "R" line on the rotor is aligned with the center of hole on the crankcase.)
- Inspect the rear cylinder's valve clearance with the same manner of the front cylinder.



SPARK PLUG

NOTE:

**Clean Initial 1,000 km and Every 4,000 km,
Replace Every 8,000 km.**

- Disconnect the spark plug caps.
- Remove the spark plugs.



TYPE	SPARK PLUG SPECIFICATION
Hot type	CR7E
Standard type	CR8E
Cold type	CR9E

Remove the carbon deposit with wire or pin and adjust the spark plug gap to 0.7~0.8 mm, measuring with a thickness gauge.

Spark plug gap	0.7~0.8 mm
-----------------------	------------

 **Thickness gauge : 09900-20806**

Check to see the worn or burnt condition of the electrodes.

If it is extremely worn or burnt, replace the plug.

And also replace the plug if it has a broken insulator, damaged thread, etc.

- Install the spark plug, and then tighten it to specified torque.

 **Spark plug : 20~25 N · m (2.0~2.5 kg · m)**

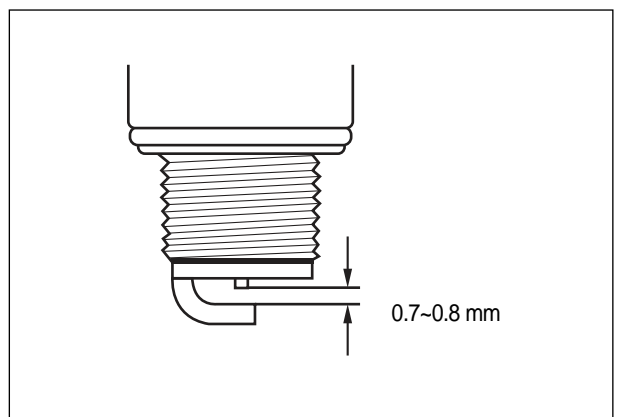
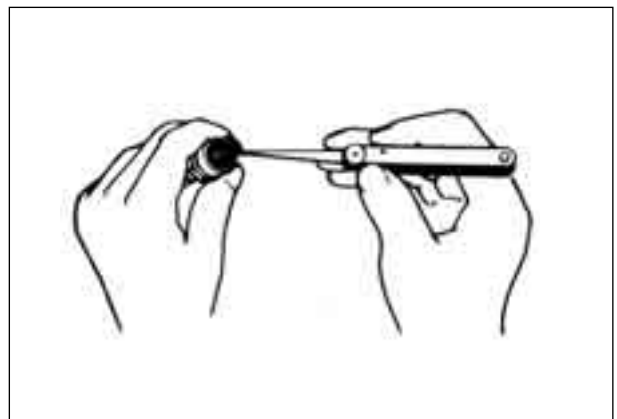

EXHAUSE PIPE NUTS AND MUFFLER MOUNTING BOLTS

NOTE:

Tighten Initial 1,000 km and Every 4,000 km.

- Tighten the exhaust pipe nuts ①, and muffler mounting bolts ② to the specified torque.

- 🔧 Exhaust pipe nut : 18~28 N · m (1.8~2.8 kg · m)
 - Muffler mounting bolt : 20~30 N · m (2.0~3.0 kg · m)



[Front Cylinder]

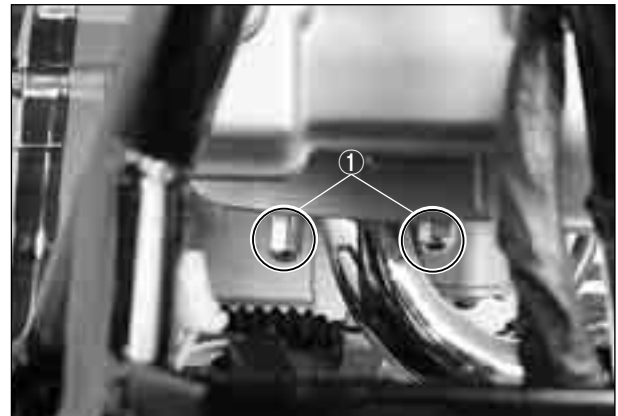

[Rear Cylinder]



AIR CLEANER

NOTE:

*Clean Every 3,000 km,
Replace Every 12,000 km.*

- Remove the air cleaner case cover ③.

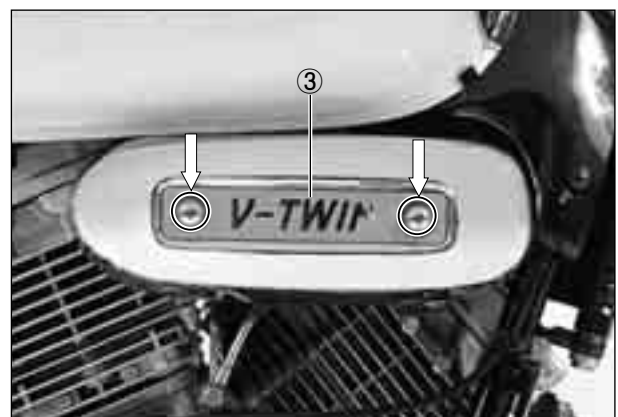

2-7 PERIODIC MAINTENANCE

- With the three of air cleaner cap mounting bolts removed, remove the air cleaner cap ①.

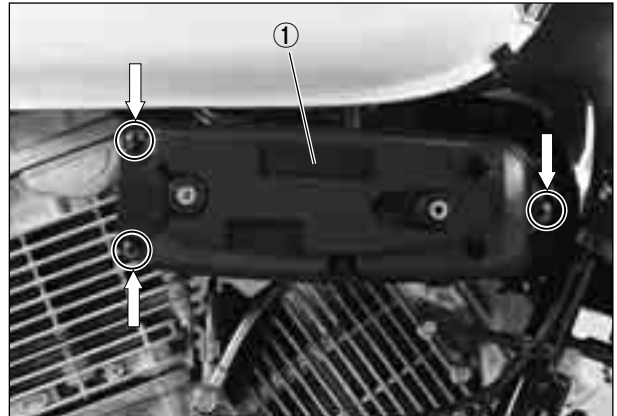

- Remove the air cleaner element ②.

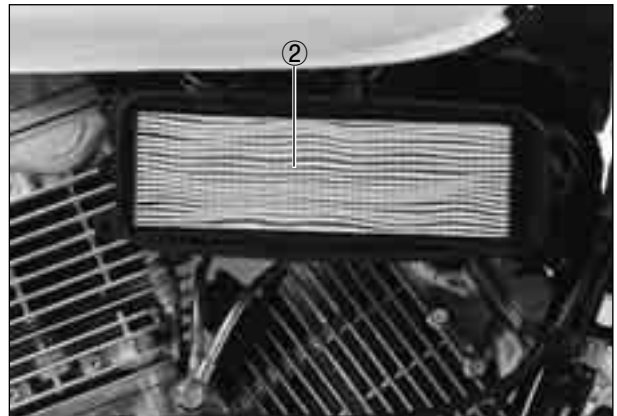

Clean the air cleaner element for the following:

- When the air cleaner element clean with the air gun, necessarily blow at the inside by compressed air.
- Carefully examine the air cleaner element for tears during cleaning. Replace it with a new one if it is torn.
- Assemble the element completely or damage severely the engine.
- Be careful not to allow water to go inside the air cleaner element.

⚠ CAUTION

More frequent servicing may be performed on motorcycles that are used under severe conditions, also clean the air cleaner element when replacing the oil to prevent damage of the engine.

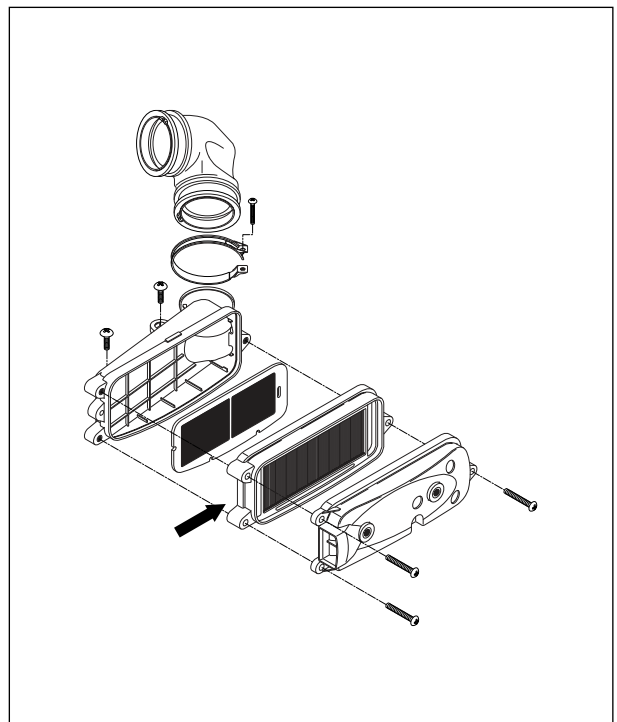

CARBURETOR

NOTE:

Inspect Initial 1,000 km and Every 4,000 km.

⊙ IDLE SPEED

⚠ CAUTION

Make this inspection when the engine is hot.

- Connect an engine tachometer to the high tension cord.
Start up the engine and set its speed at anywhere 1,450 and 1,550 rpm by turning throttle stop screw ①.

Engine idle speed	1,450~1,550 rpm
--------------------------	-----------------

 **Engine tachometer : 09900-26006**



⊙ THROTTLE CABLE PLAY

There should be 0.5~1.0 mm play on the throttle cable.
To adjust the throttle cable play.

- Tug on the throttle cable to check the amount of play.
- Loosen the lock nut ② and turn the adjuster ③ in or out until the specified play is obtained.
- Secure the lock nuts while holding the adjuster in place.

Throttle cable play [Ⓐ]	0.5~1.0 mm
---	------------

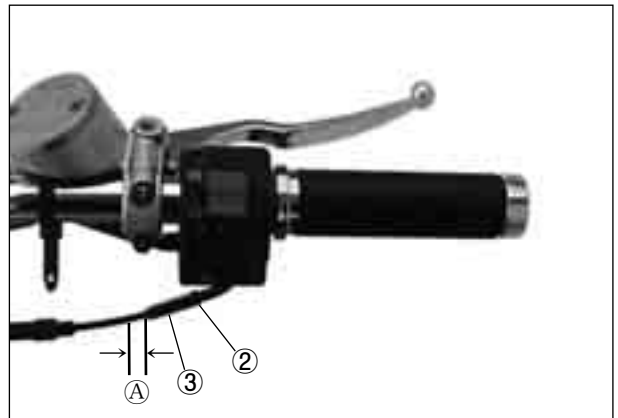

FUEL HOSE

NOTE:

*Inspect Initial 1,000 km and Every 4,000 km,
Replace every 4 years.*

- Remove the left frame cover. (Refer to page 6-3)
Inspect the fuel hoses for damage and fuel leakage. If any defects are found, the fuel hoses must be replaced.



2-9 PERIODIC MAINTENANCE

CLUTCH

NOTE:

Inspect Initial 1,000 km and Every 4,000 km.

Clutch play should be 4 mm as measured at the clutch lever holder before the clutch begins to disengage. If the play in the clutch is incorrect, adjust it in the following way :

- Loosen the lock nut ① and screw the adjuster ② on the clutch lever holder all the way in.
- Loosen clutch cable adjuster lock nut ③.
- Turn the clutch cable adjuster ④ in or out to acquire the specified play.
- Tighten lock nut while holding the adjuster in position.
- The clutch cable should be lubricated with a light weight oil whenever it is adjusted.

Clutch cable play ⑧

4 mm

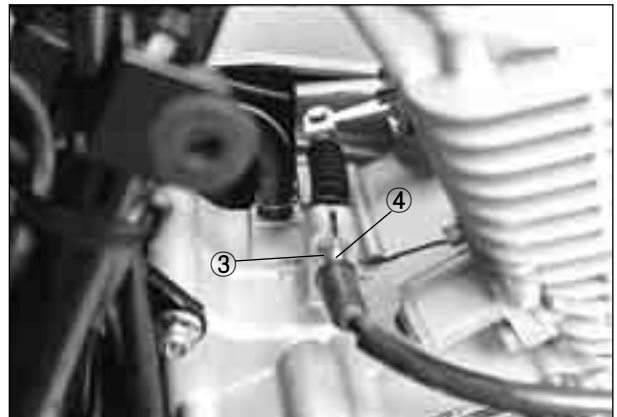
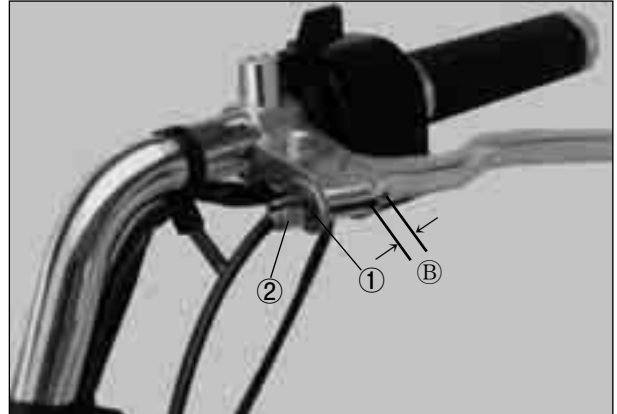

⊙ GEARSHIFT LEVER HEIGHT ADJUSTMENT

- Loosen the lock nut ⑤.
- With the link rod ⑥ turned, adjust the gearshift lever height.

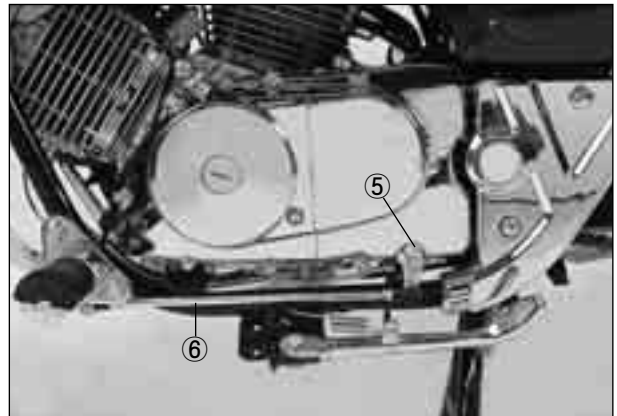

ENGINE OIL

NOTE:

Replace Initial 1,000 km and Every 4,000 km.

Necessary amount of engine oil	
Oil change	1,450 ml
Filter change	1,500 ml
Overhaul engine	1,800 ml
Engine oil type	SAE 10W40 API SF or SG

Oil should be changed while the engine is warm. Oil filter replacement at the above intervals, should be together with the engine oil change.

- Keep the motorcycle upright.
- Place an oil pan below the engine, and drain the oil by removing the filter cap ① and drain plug ②.
- Tighten the drain plug ② to the specified torque, and pour fresh oil through the oil filter. Use an API classification of SF or SG oil with SAE 10W40 viscosity.

 **Oil drain plug : 18~20 N · m (1.8~2.0 kg · m)**

- Start up the engine and allow it to run for several minutes at idling speed.
- Turn off the engine and wait about three minutes, then check the oil level through the inspection window. If the level is below mark “F”, add oil to “F” level. If the level is above mark “F”, drain oil to “F” level.

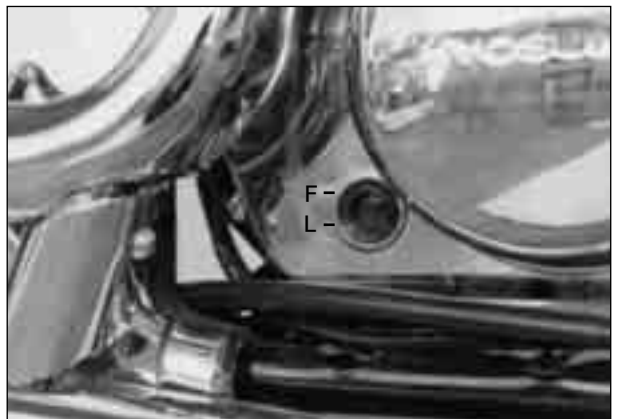
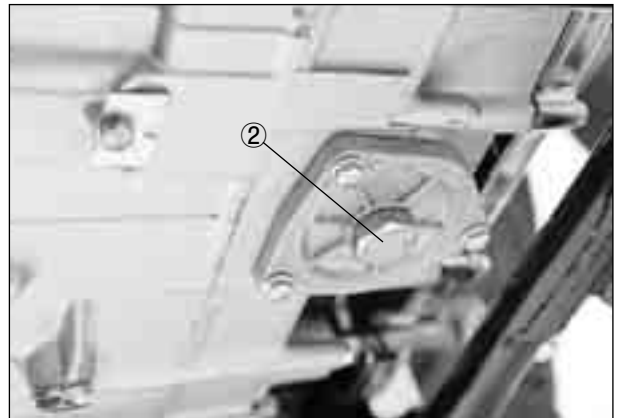

⚠ CAUTION

Never operate the motorcycle if the engine oil level is below the Lower line mark(L) in the engine oil level gauge. Never fill the engine oil above the Upper line mark(F) .

Engine oil level being most suitable about 1mm under the Upper line mark(F) of the engine oil lens. In case of the engine oil pouring in excessively, the engine output being made insufficient. Be careful not to pouring in the engine oil excessively.

⚠ CAUTION

Necessarily, confirm and clean the oil strainer ③ when replace the Engine oil (specially, when first replacement).

⚠ CAUTION

More frequent servicing may be performed on motorcycles that are used under severe conditions.

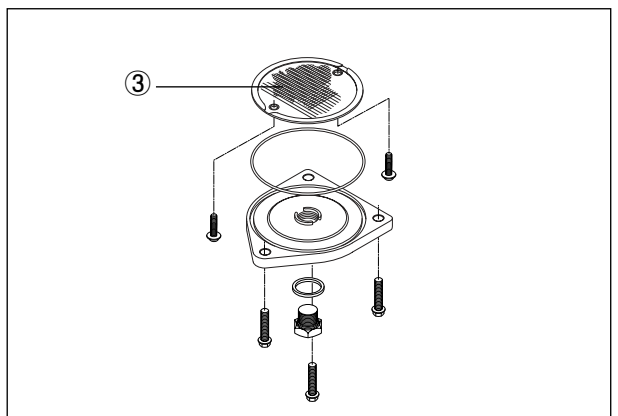

ENGINE OIL FILTER

NOTE:

Replace Initial 1,000 km and Every 4,000 km.

- Drain the engine oil as described in the engine oil replacement procedure.
- Remove the oil filter cap ①.
- Remove the oil filter.
- Install the new O-ring ②.

- Install the new oil filter.
- Install the new O-ring ③ and spring ④ to the oil filter cap.
- Install the oil filter cap.

NOTE:

Before installing the oil filter cap, apply engine oil lightly to the new O-ring ③.

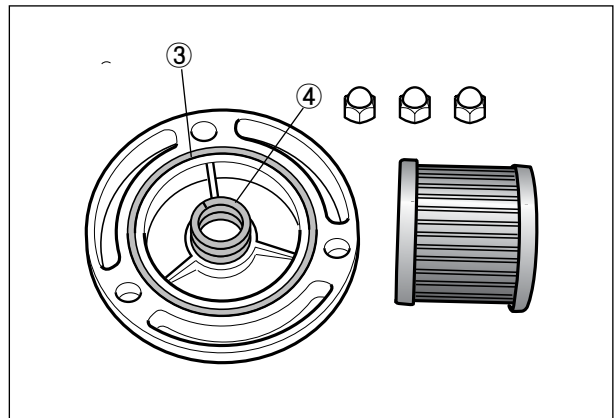
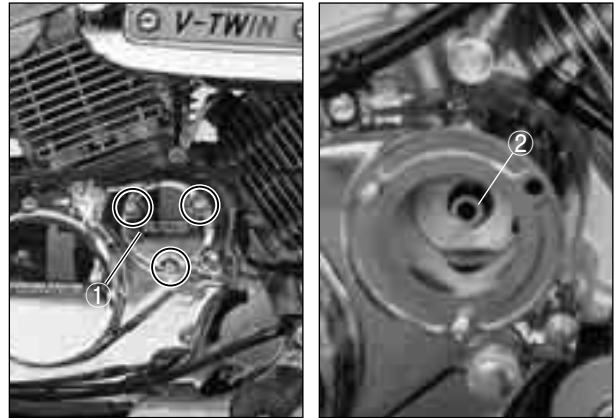

⊙ OIL FILTER INSTALLATION

⚠ CAUTION

When install the oil filter, necessarily, **HYOSUNG** character and **16510H05240** part s NO. install toward the outside, otherwise can damage the engine.

⚠ WARNING

Engine oil and exhaust pipes can be hot enough to burn you.
Wait until the oil drain plug and exhaust pipes are cool enough to touch with bare hands before draining oil.

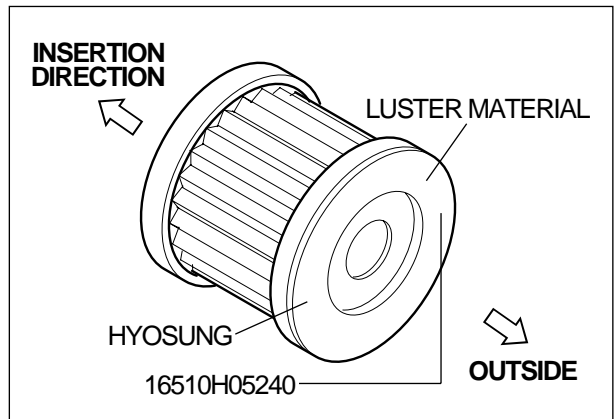

- Add new engine oil and check the oil level as described in the engine oil replacement procedure.

CAUTION

Use **HYOSUNG MOTORCYCLE GENUINE OIL FILTER** only, since the other make s genuine filters and after-market parts may differ filtering performance and durability, which could cause engine damage or oil leaks. Hyosung motors genuine oil filter is also not usable for the motorcycles.

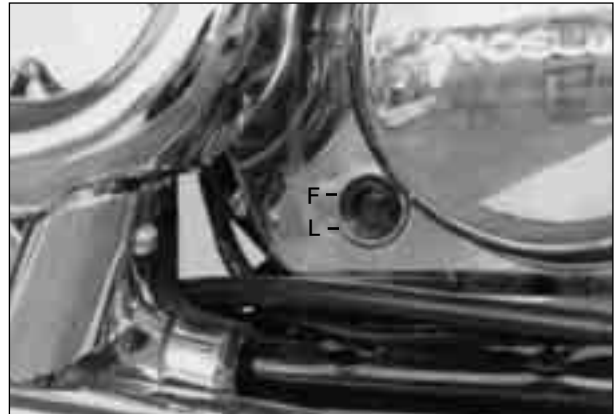

DRIVE CHAIN

NOTE:

Clean and Lubricate Every 1,000 km.

Visually check the drive chain for the possible defects listed below. (Support the motorcycle by the jack or block, turn the rear wheel slowly by hand with the transmission shifted to Neutral.)

- Loose pins
- Excessive wear
- Damaged rollers
- Improper chain adjustment
- Dry or rusted links
- Kinked or binding links

If any defects are found, the drive chain must be replaced.

NOTE:

When replacing the drive chain, replace the drive chain and sprocket as a set.

- Loose the axle nut ①.
- Tense the drive chain fully by turning both chain adjusters ②, ③.

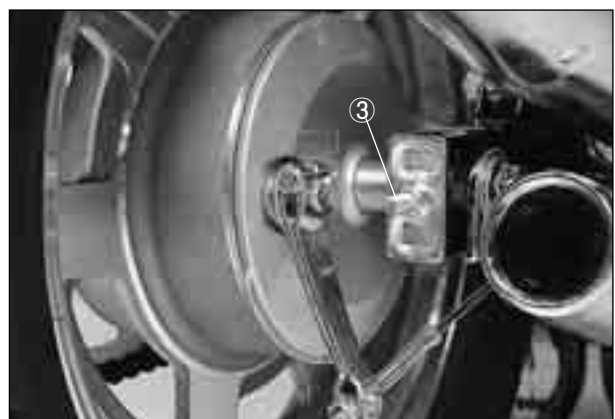
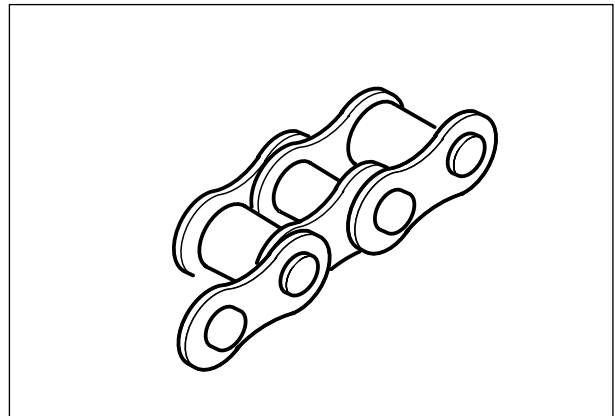

2-13 PERIODIC MAINTENANCE

- Count out 21 pins (20 pitches) on the chain and measure the distance between the two points. If the distance exceeds the service limit, the chain must be replaced.

Drive chain 20-pitch length	Service limit
	319.4 mm

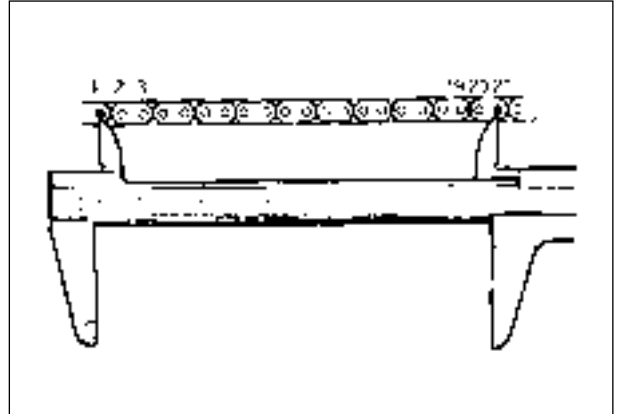

- Loosen or tighten both chain adjusters ①, ② until the chain has 20 ~ 30 mm of slack in the middle between the engine and rear sprockets. The marks ③, ④ on both chain adjusters must be at the same position on the scale to ensure that the front and rear wheels are correctly aligned.

Drive chain slack	20 ~ 30 mm
--------------------------	------------

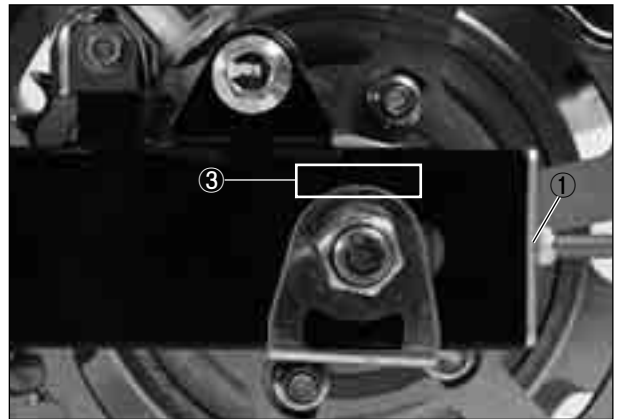

- Place the motorcycle on jack or block for accurate adjustment.
 - After adjusting the drive chain, tighten the axle nut to the specified torque.
 - Tighten both chain adjusters ①, ② securely.
- 🔧 Rear axle nut : 90~140 N · m (9.0~14.0 kg · m)**

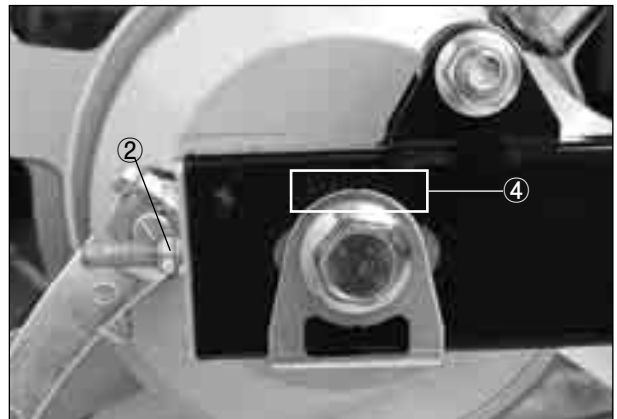

- Recheck the drive chain slack after tightening the axle nut.

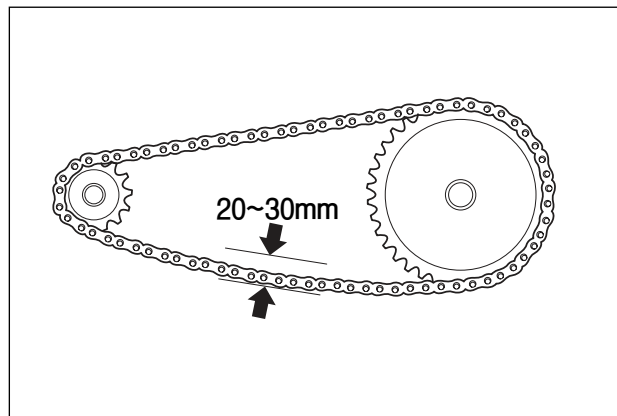

- Wash the drive chain with kerosine. If the drive chain tends to rust quickly, the intervals must be shortened.
- After washing and drying the chain, oil it with a engine oil.

⚠ CAUTION

❖ The standard drive chain is a RK-520DS Hyosung recommends that this standard drive chain should be used for the replacement.

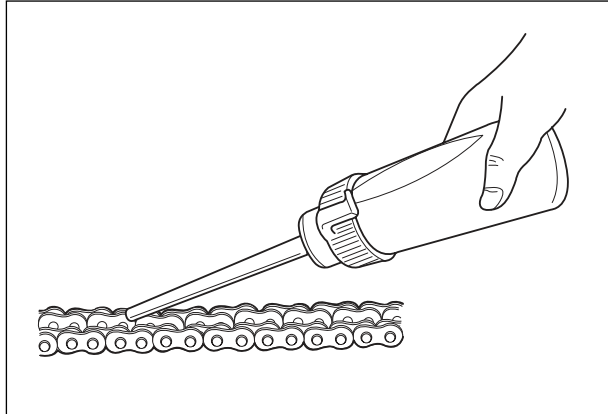

BRAKE SYSTEM

NOTE:

[BRAKE]

Inspect Initial 1,000 km and Every 4,000 km.

[BRAKE HOSE & BRAKE FLUID]

Inspect Initial 1,000 km and Every 4,000 km.

Replace the brake hoses Every 4 years,

Replace the brake fluid Every 2 years.

⊙ **BRAKE FLUID LEVEL CHECK**

- Keep the motorcycle upright and place the handle-bars straight.
- Check the brake fluid level by observing the lower limit line (LOWER) on the front brake fluid reservoir.
- When the level is below the lower limit line (LOWER), replenish with brake fluid that meets the following specification.

 **Specification and Classification : DOT 3 or DOT 4**

⚠ CAUTION

The brake system of this motorcycle is filled with a glycol-based brake fluid. Do not use or mix different types of fluid such as silicone-based or petroleum-based. Do not use any brake fluid taken from old, used or unsealed containers. Never re-use brake fluid left over from the last servicing or stored for a long period.

⚠ CAUTION

Brake fluid, if it leaks, will interfere with safe running and immediately discolor painted surfaces. Check the brake hoses and hose joints for cracks and oil leakage before riding.



⊙ **BRAKE PAD WEAR**

The extend of brake pad wear can be checked by observing the grooved limit (A) on the pad. When the wear exceeds the grooved limit, replace the pads with new ones.

⚠ CAUTION

Replace the brake pad as a set, otherwise braking performance will be adversely affected.

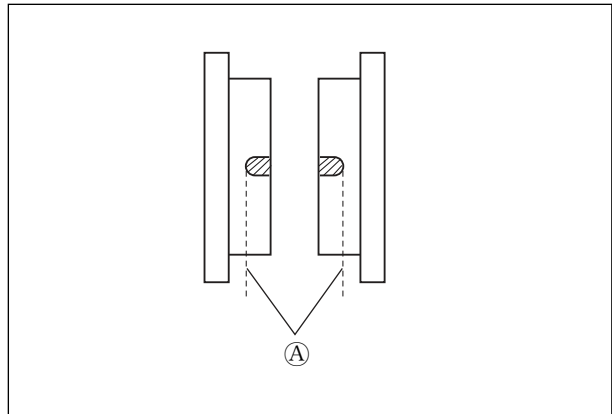

⊙ **FRONT BRAKE PAD REPLACEMENT**

- Remove the brake caliper.
- Remove the brake pads.
- To reassemble, reverse the above sequence.

🔧 Brake caliper mounting bolt
: 18~28 N · m (1.8~2.8 kg · m)



⊙ **FRONT BRAKE FLUID REPLACEMENT**

- Place the motorcycle on a level surface and keep the handlebars straight.
- Remove the master cylinder reservoir cap and diaphragm.
- Suck up the old brake fluid as much as possible.
- Fill the reservoir with new brake fluid.

🛢 Specification and Classification
: DOT 3 or DOT 4

- Connect a clear hose (1) to the air bleeder valve and insert the other end of the hose into a receptacle.

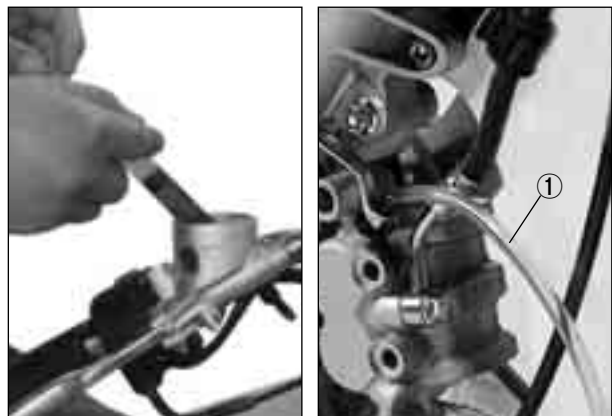

- Loosen the air bleeder valve and pump the brake lever until the old brake fluid is completely out of the brake system.



- Close the air bleeder valve and disconnect the clear hose. Fill the reservoir with new brake fluid to the upper line.

 **Front brake caliper air bleeder valve**
:6~9 N · m (0.6~0.9 kg · m)

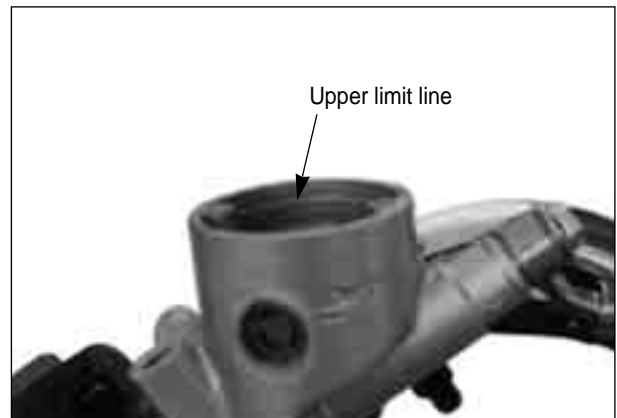

⊙ AIR BLEEDING OF THE BRAKE FLUID CIRCUIT

Air trapped in the brake fluid circuit acts like a cushion to absorb a large proportion of the pressure developed by the master cylinder and thus interferes with the full braking performance of the brake caliper. The presence of air is indicated by “sponginess” of the brake lever and also by lack of braking force. Considering the danger to which such trapped air exposes the machine and rider, it is essential that, after remounting the brake and restoring the brake system to the normal condition, the brake fluid circuit be purged of air in the following manner :

- Fill the master cylinder reservoir to top of the inspection window. Replace the reservoir cap to prevent dirt from entering it.
- Attach a hose to the air bleeder valve, and insert the free end of the hose into a receptacle.
- Bleed air from the brake system.
- Squeeze and release the brake lever several times in rapid succession and squeeze the lever fully without releasing it. Loosen the bleeder valve by turning it a quarter of a turn so that the brake fluid runs into the receptacle, this will remove the tension of the brake lever causing it to touch the handlebar grip. Then, close the air bleeder valve, pump and squeeze the brake lever, and open the valve. Repeat this process until the fluid flowing into the receptacle no longer contains air bubbles.

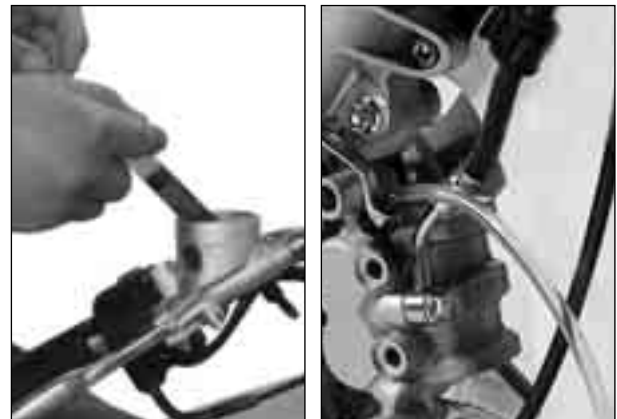

2-17 PERIODIC MAINTENANCE

NOTE:

While bleeding the brake system, replenish the brake fluid in the reservoir as necessary. Make sure that there is always some fluid visible in the reservoir.

- Close the air bleeder valve, and disconnect the hose.
Fill the reservoir with brake fluid to the upper line.

- 🔧 **Front brake caliper air bleeder valve**
: 6~9 N · m (0.6~0.9 kg · m)

⚠ CAUTION

Handle brake fluid with care : the fluid reacts chemically with paint, plastics, rubber materials, etc.

⊙ REAR BRAKE PEDAL HEIGHT

- Loosen the lock nut.
- Adjust the brake pedal height ① by turning the adjuster ②.

Rear brake pedal height ①	310 mm (When one person riding at the ground)
----------------------------------	--

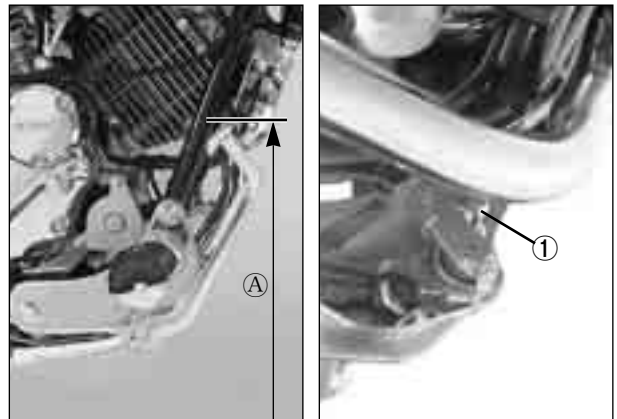
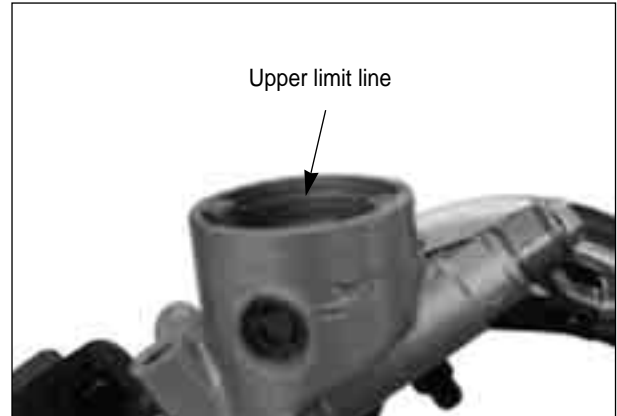

⊙ REAR BRAKE ADJUSTING

- Adjust the free travel ③ to 20~30 mm by turning the adjusting nut ②.

Rear brake pedal free travel ③	20~30 mm
---------------------------------------	----------

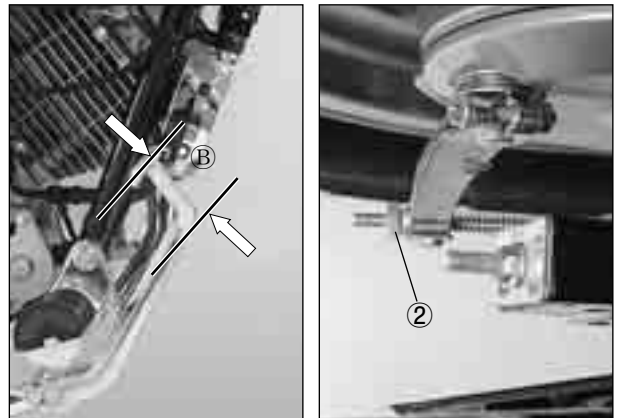

⊙ REAR BRAKE SHOE WEAR

This motorcycle is equipped with brake lining wear limit indicator on the rear brake.

To check brake lining wear, perform the following steps.

- Make sure that the rear brake is properly adjusted.
- Depress the rear brake pedal. Make sure that the extension line ③ from the index mark is within the range ④ embossed on the brake panel.
- If the extension line ③ goes beyond the range, the brake shoe assembly should be replaced with a new set of shoes. (Refer to page 6-39)

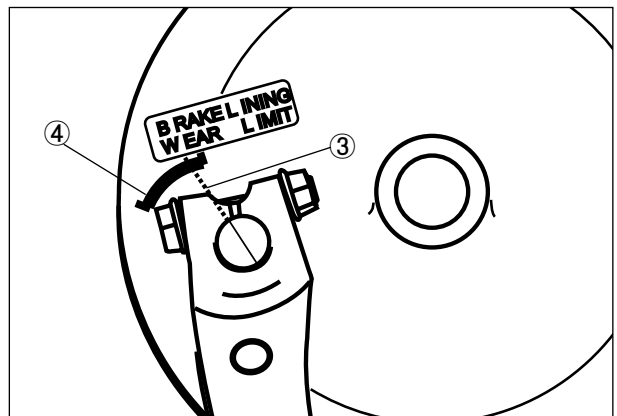

⊙ **BRAKE LAMP SWITCH**

Adjust the rear brake lamp switch so that the brake lamp will come on just before pressure is felt when the brake pedal is depressed.



STEERING

NOTE :

Inspect Initial 1,000 km and Every 4,000 km.

Steering should be adjusted properly for smooth turning of handlebars and safe running. Overtight steering prevents smooth turning of the handlebars and too loose steering will cause poor stability. Check that there is no play in the steering stem while grasping the lower fork tubes by supporting the machine so that the front wheel is off the ground, with the wheel straight ahead, and pull forward. If play is found, perform steering bearing adjustment as described in page 6-30 of this manual.



FRONT FORK

NOTE :

Inspect Every 4,000 km.

Inspect the front forks for oil leakage, scoring or scratches on the outer surface of the inner tubes. Replace any defective parts, if necessary.



REAR SUSPENSION

NOTE :

Inspect Every 4,000 km.

Inspect the rear shock absorber for oil leakage and mounting rubbers including engine mounting for wear and damage. Replace any defective parts, if necessary. (Refer to page 6-43)



2-19 PERIODIC MAINTENANCE

TIRE

NOTE :

Inspect Initial 1,000 km and Every 4,000 km.

⊙ TIRE TREAD CONDITION

Operating the motorcycle with excessively worn tires will decrease riding stability and can lead to loss of control.

- Inspect storage of tire thread s depth by the 『 tire wear indicator 』.
- Replace the front and rear tires at once when appear the 『 tire wear indicator 』.

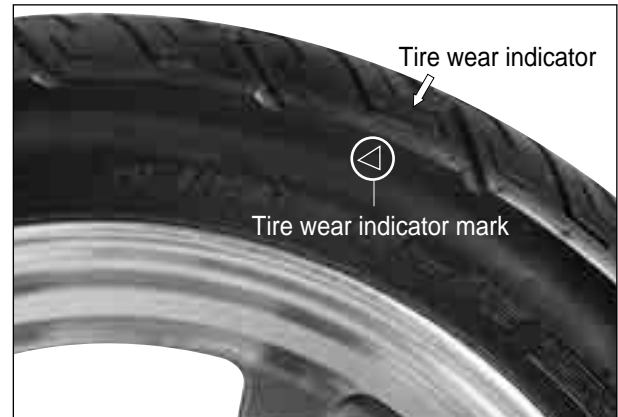

⊙ TIRE PRESSURE

If the tire pressure is too high or too low, steering will be adversely affected and tire wear increased. Therefore, maintain the correct tire pressure for good roadability or shorter tire life will result. Cold inflation tire pressure is as follows.

COLD INFLATION TIRE PRESSURE	SOLD RIDING			DUAL RIDING		
	KPa	kgf/cm ²	psi	KPa	kgf/cm ²	psi
Front	172	1.75	25	172	1.75	25
Rear	196	2.00	29	221	2.25	32

⚠ CAUTION

The standard tire on *Aquila 250* is 110/90-16 59S for front and 150/80-15M/C 70S for rear. The use of tires other than those specified may cause instability. It is highly recommended to use a HYOSUNG Genuine Tire.

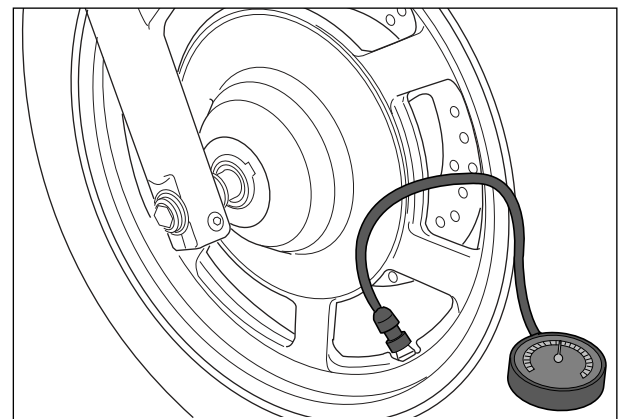

CHASSIS BOLTS AND NUTS

NOTE :

Tighten Initial 1,000 km and Every 4,000 km.

Check that all chassis bolts and nuts are tightened to their specified torque.(Refer to page 7-12)

COMPRESSION PRESSURE

The compression of a cylinder is a good indicator of its internal condition.

The decision to overhaul the cylinder is often based on the results of a compression test. Periodic maintenance records kept at your dealership should include compression reading for each maintenance service.

Compression pressure	
Standard	14~16 kg/cm ² (at 600 rpm)
Service limit	12 kg/cm ² (at 600 rpm)

Low compression pressure can indicate any of the following conditions :

- Excessively worn cylinder wall
- Worn-down piston or piston rings
- Piston rings stuck in grooves
- Poor seating of valves
- Ruptured or otherwise defective cylinder head gasket

⊙ COMPRESSION TEST PROCEDURE

NOTE:

- ❖ *Before testing the engine for compression pressure, make sure that the cylinder head bolts are tightened to the specified torque values and valves are properly adjusted.*
- ❖ *Have the engine warmed up by idling before testing.*
- ❖ *Be sure that the battery used is in fully-charged condition.*

Remove the parts concerned and test the compression pressure in the following manner.

- Loosen the oil cooler mounting bolts from the frame.
- Remove all the spark plug.
- Fit the compression gauge in one of the plug holes, while taking care that the connection is tight.
- Keep the throttle grip in full-open position.
- Crank the engine a few seconds with the starter, and record the maximum gauge reading as the compression of that cylinder.

 **Compression gauge : 09915-64510**



OIL PRESSURE

Check the oil pressure periodically. This will give a good indication of the condition of the moving parts.

Oil pressure	Standard
	1.3 ± 0.2 kg/cm ² (at 60 °C · 4,000 rpm)

If the oil pressure is lower or higher than the specification, the following causes may be considered.

⊙ LOW OIL PRESSURE

- Oil leakage from the oil passage
- Damaged O-ring
- Defective oil pump
- Combination of above items

⊙ HIGH OIL PRESSURE

- Engine oil viscosity is too high
- Clogged oil passage
- Combination of the above items

⊙ OIL PRESSURE TEST PROCEDURE

Check the oil pressure in the following manner.

- Remove the oil check plug and install the adapter of oil pressure gauge at the removed position.
- Connect an engine tachometer.
- Warm up the engine as follows :
Summer 10 min. at 2,000 rpm.
Winter 20 min. at 2,000 rpm.
- After warming up, increase the engine speed to 4,000 rpm. (with the engine tachometer), and read the oil pressure gauge.



Oil pressure gauge : 09915-74510

Engine tachometer : 09900-26006



ENGINE

CONTENTS

ENGINE REMOVAL AND REINSTALLATION	3- 1
ENGINE REMOVAL	3- 1
ENGINE REINSTALLATION	3- 6
ENGINE DISASSEMBLY	3- 8
STARTER MOTER	3- 8
CYLINDER HEAD COVER	3- 9
PISTON	3-13
MAGNETO COVER	3-14
MAGNETO ROTOR	3-14
CLUTCH COVER	3-15
CLUTCH	3-16
PRIMARY DRIVE GEAR	3-17
OIL PUMP	3-17
GEARSHIFT SHAFT	3-18
ENGINE COMPONENT INSPECTION AND SERVICE	3-20
ENGINE REASSEMBLY	3-39

CAUTION

- ❖ Mark an identification of assembly location on each removed part so that each will be restored to the original position during reassembly.
- ❖ Wash clean and dry the removed parts before inspecting and measuring.
- ❖ Oil the rotating or sliding parts before assembly.
- ❖ Make sure to use the correct type of lubricant where specified.
- ❖ Check that each rotating or sliding part moves or operates smoothly after assembly.
- ❖ Make sure to follow the bolt tightening order where specified.
- ❖ If the correct length of the bolt is confused when tightening the crankcase or cover, insert all the bolts and check that the tightening margin is equal in each bolt.

ENGINE REMOVAL AND REINSTALLATION

ENGINE REMOVAL

NOTE:

If the engine is dirtied, wash the machine with a suitable cleaner before removing the engine.

- Remove the front seat. (Refer to page 6-1)
- Remove the fuel tank. (Refer to page 4-1)
- Drain the engine oil. (Refer to page 2-10)
- Remove the right frame cover. (Refer to page 6-2)
- Disconnect the battery ⊖ lead wire ...
- Remove the the four support mounting bolts ① .
- Remove the spark plug. (Refer to page 3-3)

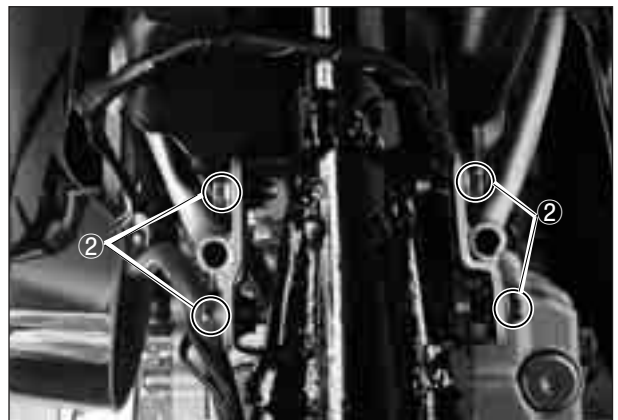

⊙ AIR CLEANER

- With the two screw loosened, remove the right air cleaner case. (Refer to page 2-6)
- Loosen the clamp screw.



- With the bolt removed, take out the air cleaner chamber.



⦿ CARBURETOR

- Remove the carburetor after removed the intake pipes.
(Refer to page 4-4)

**⦿ CLUTCH CABLE**

- Disconnect the clutch cable end out of clutch lever.



- Disconnect the clutch cable end out of clutch release arm.

**⦿ EXHAUST PIPE AND MUFFLER**

- With the exhaust pipe bolts and muffler mounting bolts removed, remove the exhaust pipes and mufflers.



[Front Cylinder]



[Rear Cylinder]



⊙ **ELECTRIC PARTS**

- With take out the spark plug caps, remove the spark plug.



[Front Cylinder]

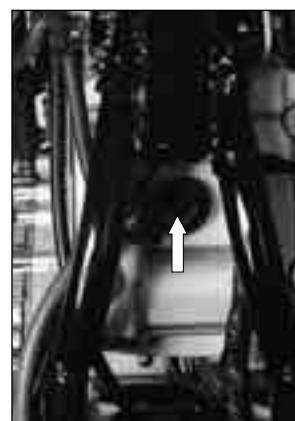

[Rear Cylinder]

- Remove the starter motor lead wire.



- Remove the engine ground lead wire ①.



- Disconnect the magneto coupler ②.



⊙ **ENGINE SPROCKET**

- Remove the engine sprocket cover.

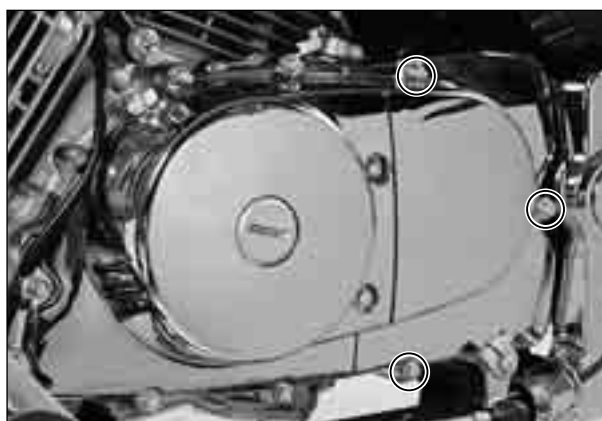

- Remove the breather hose.



3-5 ENGINE

- With the bolt removed, disconnect the gearshift arm.
- Remove the left footrest.

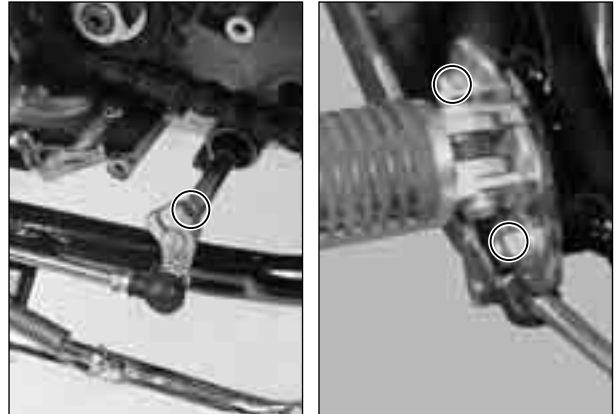

- Flatten the lock washer.
- Remove the engine sprocket nut ① and washer.

NOTE:

When loosening the engine sprocket nut, depress the brake pedal.

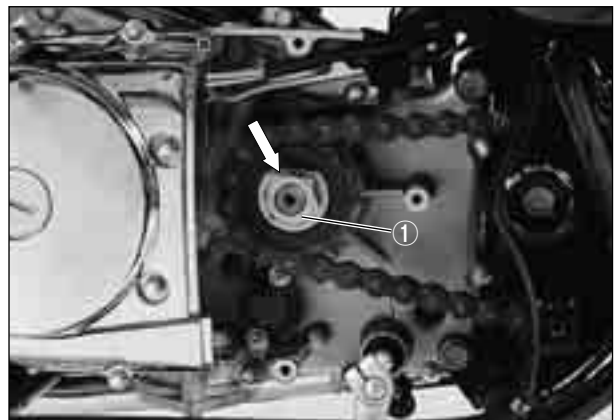

- Remove the engine sprocket.

NOTE:

If it is difficult to remove the engine sprocket, loosen the rear axle nut, chain adjusters ② · ③ to provide additional chain slack.(Refer to page 2-12)

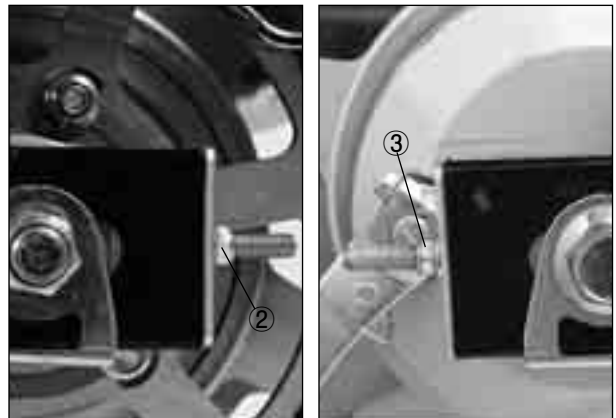

- Remove the oil cooler.



- Support the engine using an engine jack.
- Remove the engine mounting nuts and bolts.
- Remove the engine from the frame.

⚠ CAUTION

Remove the carburetor when removing or installing the engine necessarily.
When removing the carburetor, loosen the intake pipe mounting bolts at the same time.

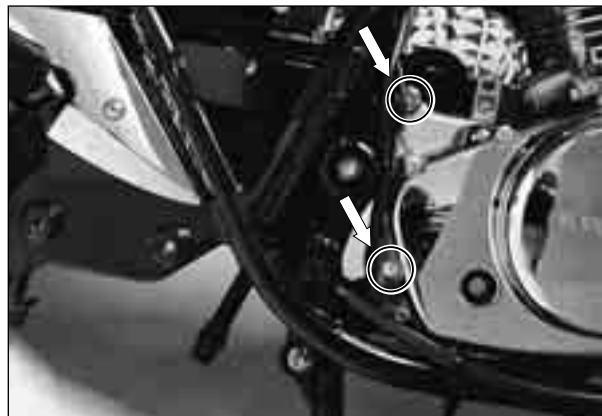

ENGINE REINSTALLATION

Reinstall the engine in the reverse order of engine removal.

- Install the engine mounting bolts and nuts.
- Tighten the engine mounting bolts and nuts to the specified torque.

⊙ ENGINE SPOCKET

- Loosen the rear axle nut and chain adjusters.
- Install the engine sprocket.



3-7 ENGINE

- Tighten the engine sprocket nut ① to the specified torque.

🔧 Engine sprocket nut
: 80~100 N · m (8.0~10.0 kg · m)

NOTE:

When tightening the engine sprocket nut, depress the rear brake pedal.

- Bend the lock washer securely.

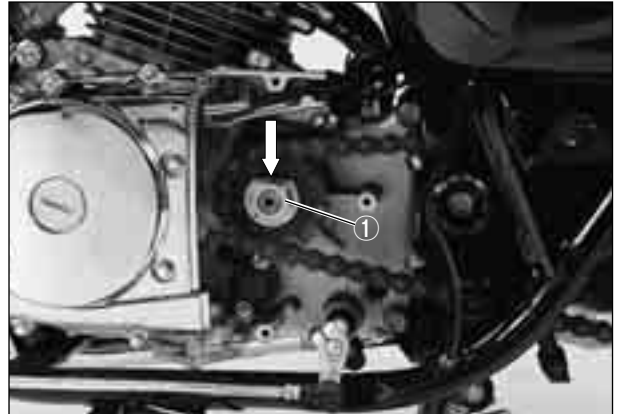

- Tighten the left footrest bolts to the specified torque.

🔧 Footrest bolt : 36~52 N · m (3.6~5.2 kg · m)



- Install the gearshift arm and adjust the gearshift lever height. (Refer to page 2-9)

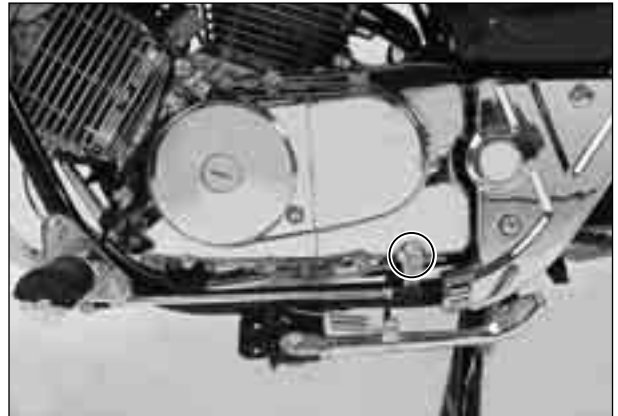

- Connect each electric part and its couplers. (Refer to page 7-20~23)
- Install the exhaust pipes and mufflers.
- Install the carburetor and air cleaner. (Refer to page 4-7)

- After remounting the engine, the following adjustments are necessary.

Engine idling speed	Refer to page 2-8
Throttle cable play	Refer to page 2-8
Clutch lever play	Refer to page 2-9
Drive chain	Refer to page 2-12
Rear brake pedal height and free travel	Refer to page 2-17
Gearshift lever height	Refer to page 2-9
Engine oil level	Refer to page 2-10

ENGINE DISASSEMBLY

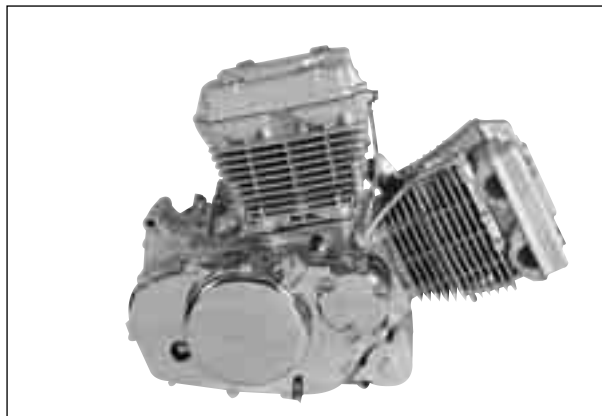

STARTER MOTOR

- Remove the starter motor.



- Remove the gear position switch.
- Remove the contacts ① and springs ②.

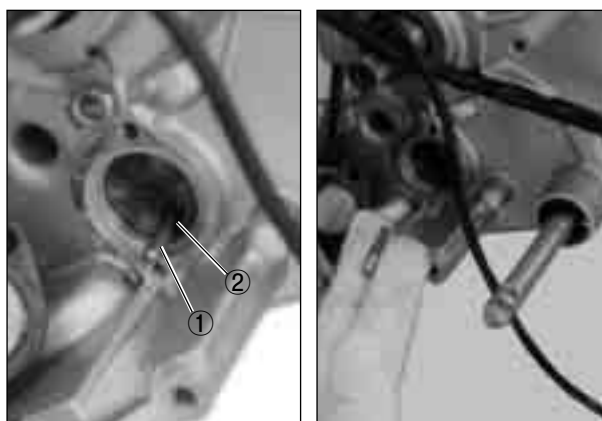

- Remove the three union bolts.



CYLINDER HEAD COVER

- Remove the cylinder head cover.

- To set the piston at TDC(Top Dead Center).

CAUTION

Align the index mark on the magneto rotor with the index mark on the magneto cover as turn the crankshaft counter-clockwise.
To set piston at TDC(Top Dead Center) of the compression stroke as align the “ | F” mark for front cylinder and the “ | R” mark for rear cylinder.

- Remove the cam chain tensioner.

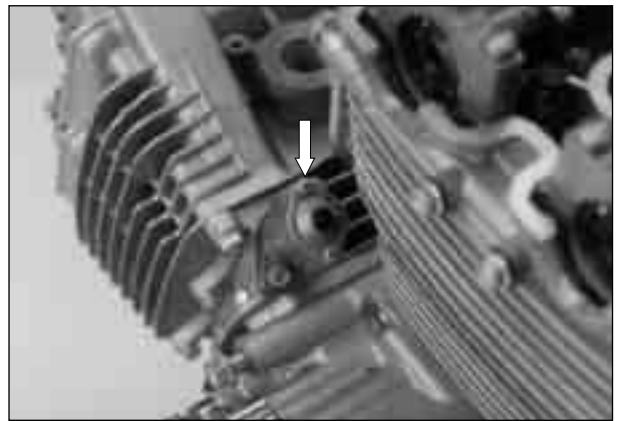
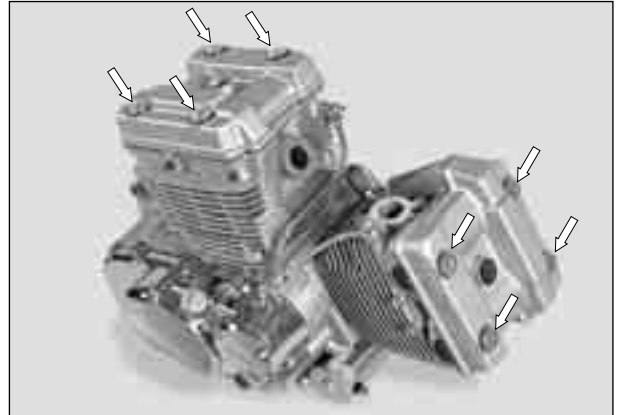

[Front Cylinder]



[Rear Cylinder]

- With the three bolts removed, remove the cam chain guide NO.2.

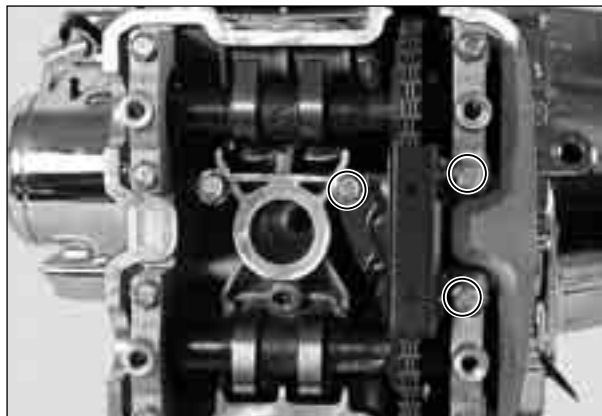

- Remove the camshaft housing.

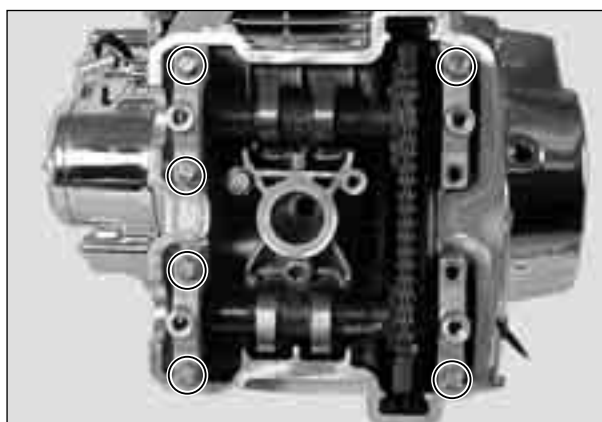

- Remove the camshaft (IN. · EX.).



- Remove the C-ring.



3-11 ENGINE

- Loosen the two cylinder head base cover nuts.



- Loosen the three cylinder head base nuts.

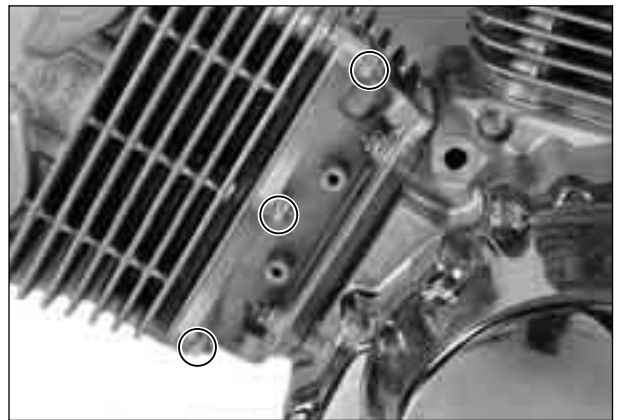

- Loosen the four cylinder head stud bolts.

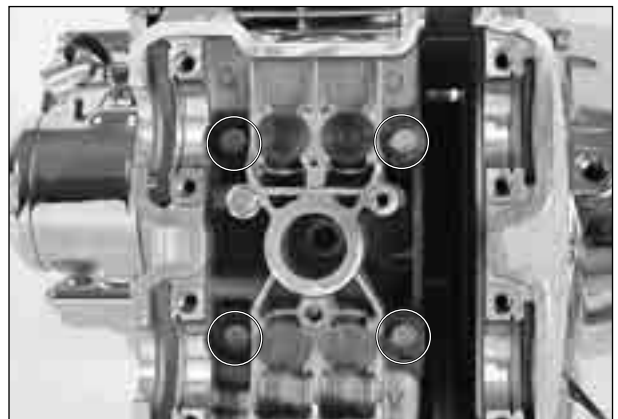

- Remove the chain guide NO.1.



- Remove the tappet and the shim.

⚠ CAUTION

Draw out the tappet and shim with the strong magnet not to be scratched.



⚠ CAUTION

The tappet and shim should be lined so that each will be restored to the original position during reassembly.

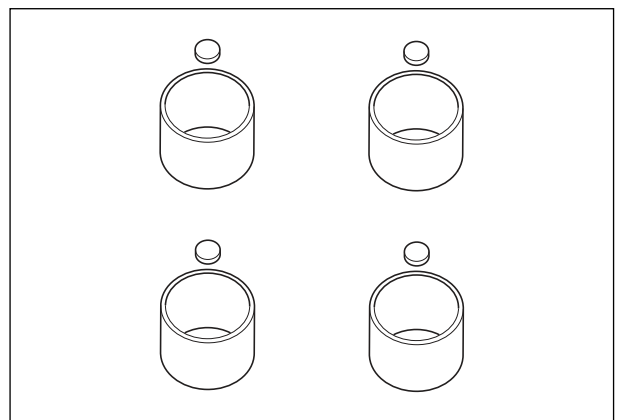

- Compress the valve spring by using the special tool.

TOOL Valve spring compressor : 09916-14510
 Valve spring compressor attachment
 : 09916H35C00

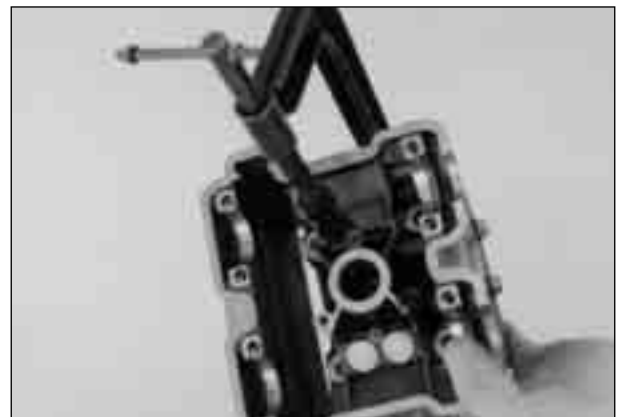

- Take out the valve cotter from the valve stem.
- Remove the valve spring retainer.
- Pull out valve from the other side.

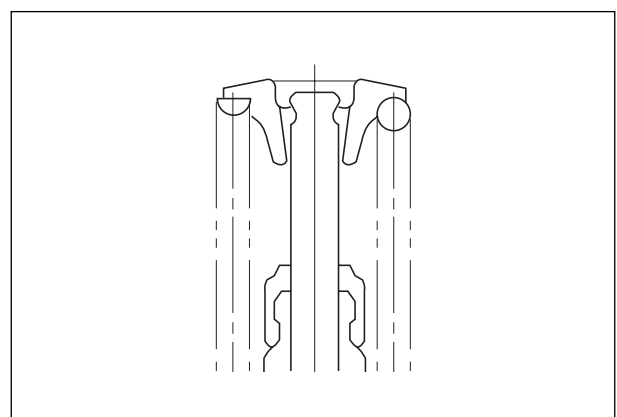

3-13 ENGINE

- Remove the two cylinder base nuts and cylinder.

CAUTION

If tapping with the plastic hammer is necessary, do not break the fins.



- Remove the rear cylinder head and cylinder with the same manner of the front cylinder head and cylinder removal.

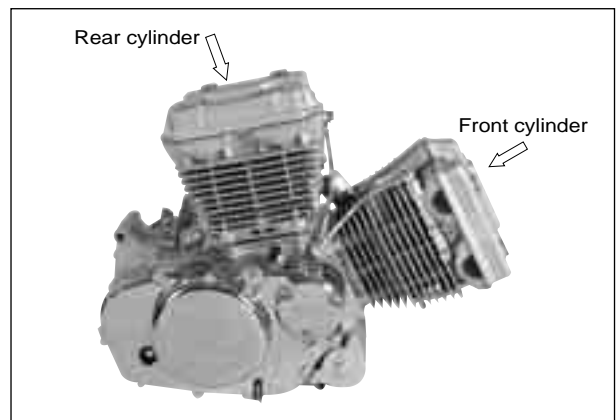

PISTON

- Place a clean rag over the cylinder base to prevent piston pin circlips from dropping into crankcase. Remove the piston pin circlips with long-nose pliers.



- Remove the piston pin by using the special tool.

TOOL Piston pin puller : 09910-34510

NOTE :

Make an identification on each piston head so that confirmed the cylinder.



MAGNETO COVER

- Remove the magneto cover.

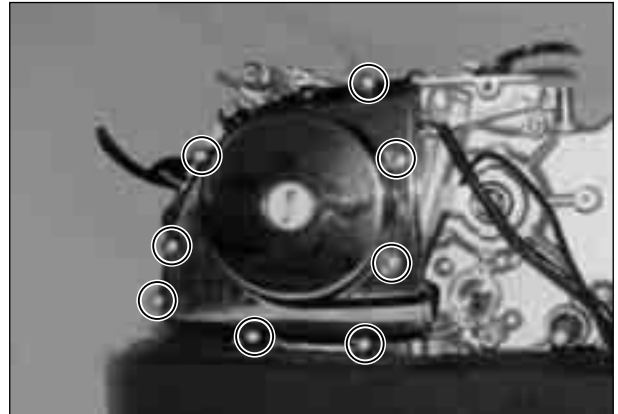

- Remove in the order of spacer ①, shaft ②, starter idle gear ③.

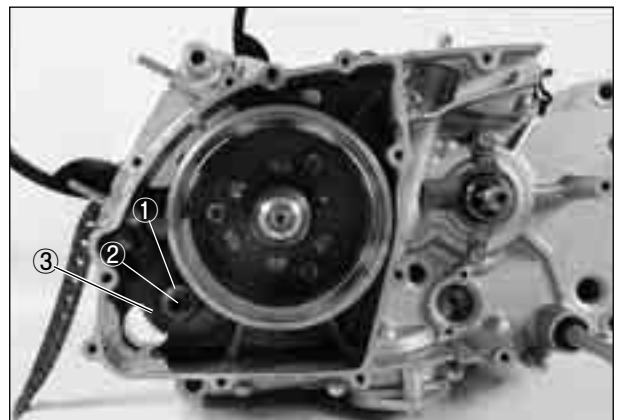
**MAGNETO ROTOR**

- With the magneto rotor held immovable using the special tool, loosen the rotor nut.

 **Conrod holder : 09910-20115**



- Remove the magneto rotor by using the special tool.

 **Rotor remover : 09930-30164**



3-15 ENGINE

- Remove the key ①.
- Remove the starter driven gear ②.

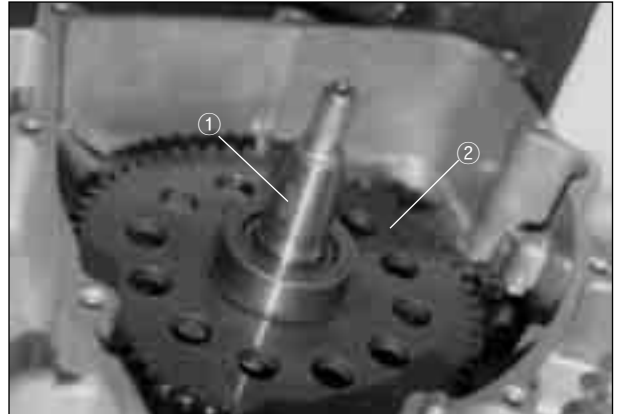

- Remove the cam chain tensioner ③ and cam chain ④.

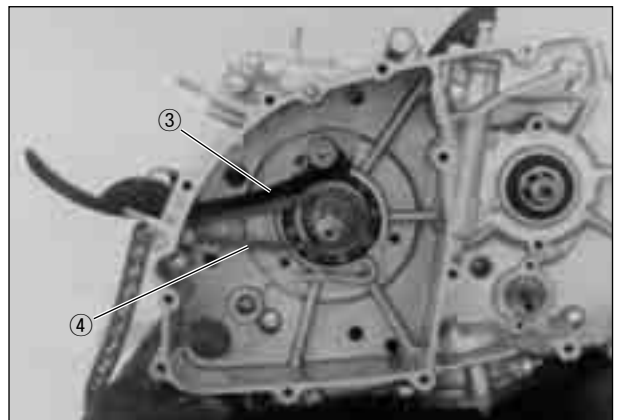

CLUTCH COVER

- Remove the clutch release arm .



- Remove the clutch cover bolts.
- Remove the clutch cover.

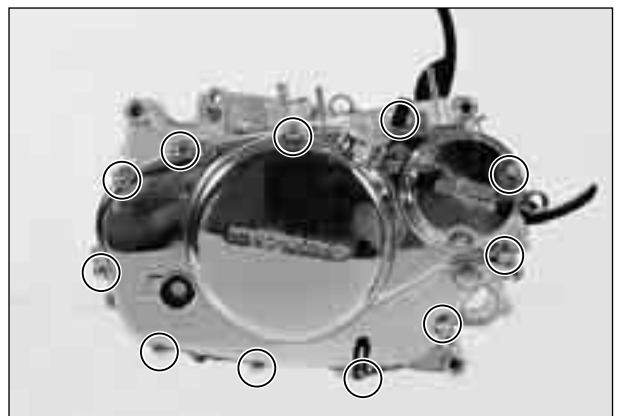

CLUTCH

- With the primary drive gear held immovable, remove the clutch spring mounting bolts diagonally.
- Remove the disk pressure ①.

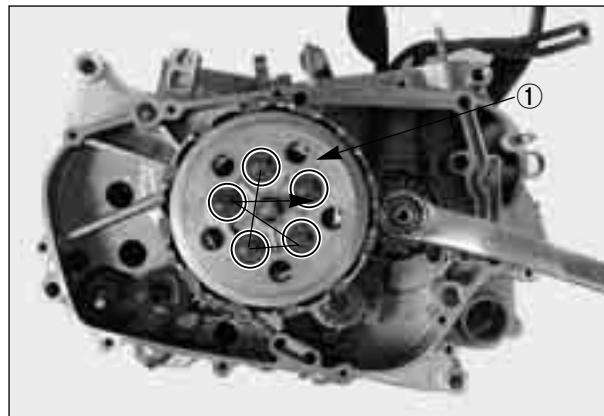

- Remove the clutch drive and driven plates.



- Flatten the lock washer ②.



- With the clutch sleeve hub held immovable using special tool, remove the clutch sleeve hub nut.

 **Clutch sleeve hub holder : 09920-53710**

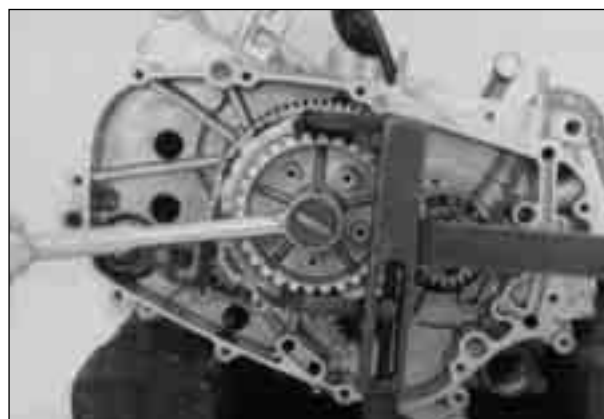

3-17 ENGINE

- Remove the clutch sleeve hub ① and primary driven gear assembly ② .

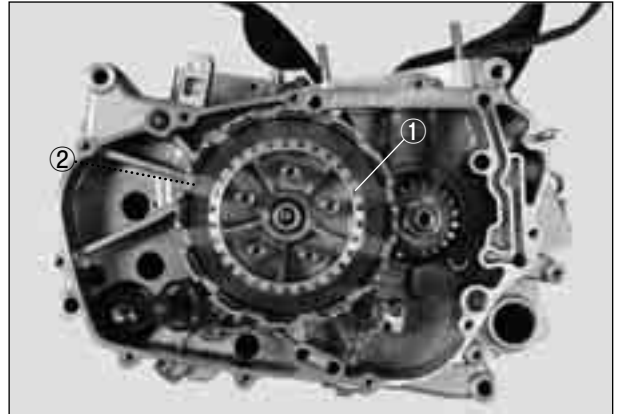

PRIMARY DRIVE GEAR

- With the magneto rotor held immovable using special tool, remove the primary drive gear nut.

 **Conrod holder : 09910-20115**

CAUTION

This bolt has left-hand thread. If turning it counter-clockwise() , it may cause damage.
Pay attention at the primary drive gear with two washer.

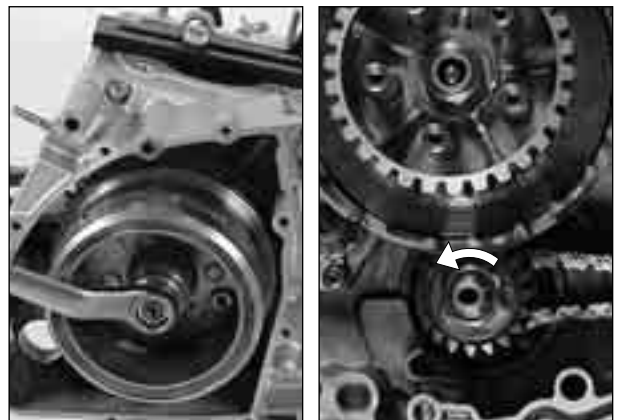

- Remove the key and cam chain ③ .
- Remove the cam chain tensioner ④ .



OIL PUMP

- Remove the circlip ⑤ and oil pump driven gear.



- Remove the pin ①.
- With the three screws loosened, remove the oil pump ②.

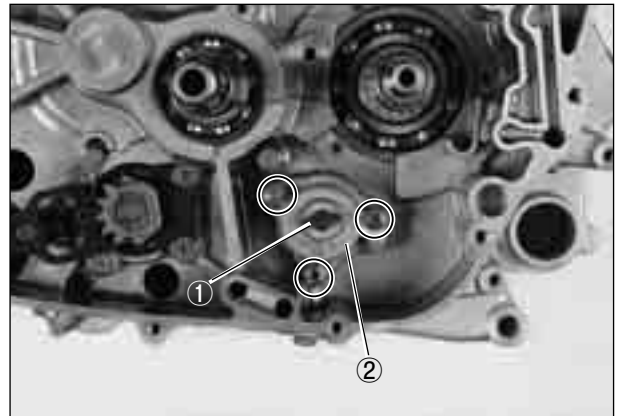

GEARSHIFT SHAFT

- Draw out the gearshift shaft ③.

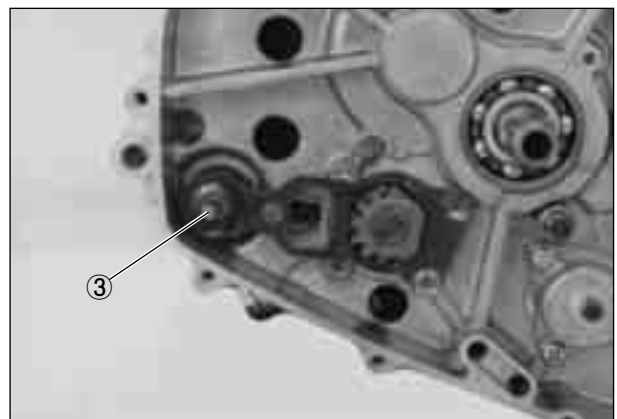

- With the cam guide screws loosened, draw out the guide and lifter.
- Remove the cam driven gear.

⚠ CAUTION

Pay attention to not lost the gearshift pawl, pin, spring with the cam driven gear removal.

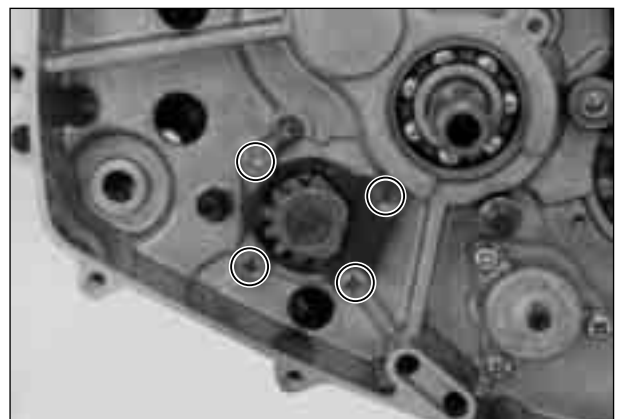

- With the neutral cam stopper plug loosened, remove the washer, spring, stopper.

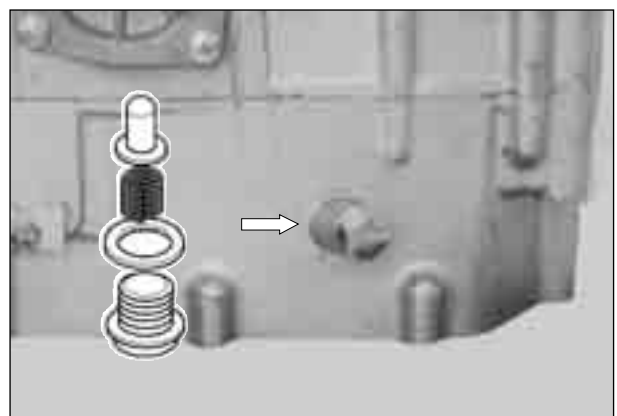

3-19 ENGINE

- Remove the crankcase securing bolts.
- Separate the crankcase into 2 parts, right and left, with a special tool.

 **Crankcase separator : 09920-13120**

CAUTION

When separating the crankcase, necessarily, remove it after installed the special tool (Crankcase separator) on the side of clutch.
In case separate oppositely, the gearshift cam stopper will be damaged in the side of magneto.

CAUTION

The crankshaft and transmission components must remain in the right crankcase half. This is necessary because the gearshift cam stopper is mounted on the right crankcase half and will be damaged if the transmission components remain in the left half.

NOTE:

*Fit the crankcase separator, so that the tool arms parallel the side of the crankcase.
The crankshaft and transmission components must remain in the left crankcase half.*

- Remove the gearshift fork shaft ① and gearshift fork ②.
- Remove the gearshift cam ③.
- Remove the driveshaft assembly ④, countershaft assembly ⑤.
- Remove the oil pump idle gearshaft ⑥.

- Remove the crankshaft by using the special tool.

 **Crankcase separator : 09920-13120**

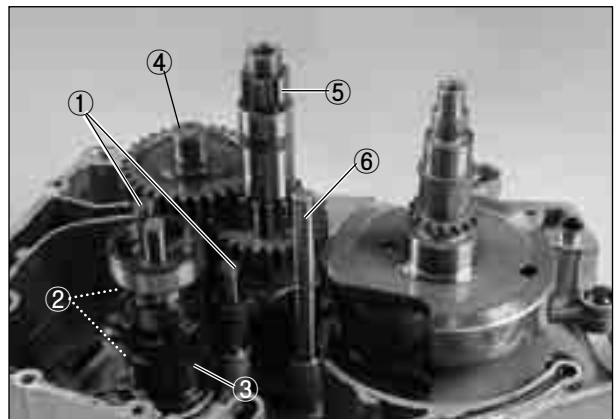
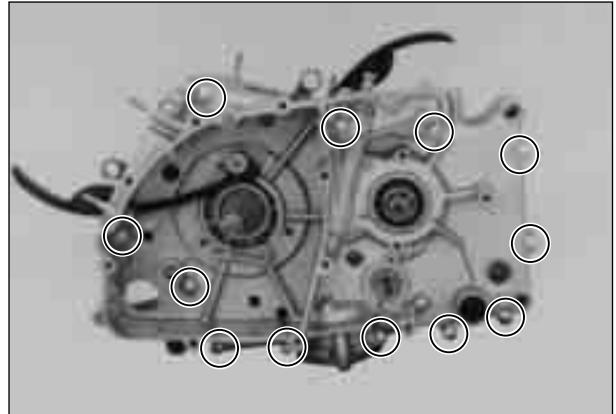

ENGINE COMPONENT INSPECTION AND SERVICE

⚠ CAUTION

Be sure to identify each removed part as to its location, and lay the parts out in groups designated as “Front cylinder”, “Rear cylinder”, “Exhaust”, “Intake”, so that each will be restored to the original location during assembly.

⦿ CYLINDER HEAD DISTORTION

Decarbonate in combustion chamber.

Check the gasketed surface of the cylinder head for distortion with a straightedge and thickness gauge, taking a clearance reading at several places as indicated. If the largest reading at any position of the straightedge exceeds the limit, replace the cylinder head.

Cylinder head distortion	Service limit
	0.05 mm

 **Thickness gauge : 09900-20806**

⦿ VALVE FACE WEAR

Visually inspect each valve face for wear. Replace any valve with an abnormally worn face. The thickness of the valve face decreases as the face wears. Measure the valve head $\text{\textcircled{T}}$. If it is out of specification, replace the valve with a new one.

Valve face wear	Service limit
	0.5 mm

 **Vernier calipers : 09900-20101**

⦿ VALVE STEM RUNOUT

Check the valve stem for abnormal wear or bend. Place the valve on V-blocks and measure runout. If the service limit is exceeded or abnormal condition exists, replace the valve.

Valve stem runout	Service limit
	0.05 mm

 **Dial gauge : 09900-20606**

Magnetic stand : 09900-20701

V-block : 09900-21304

⦿ CAMSHAFT

The camshaft should be checked for runout and also for wear of cams and journals if the engine has been noted to produce abnormal noise or vibration or a lack of output power. Any of these abnormality could be caused by a worn camshaft.

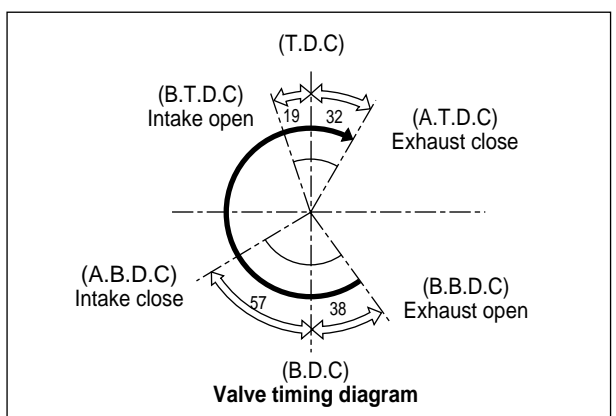
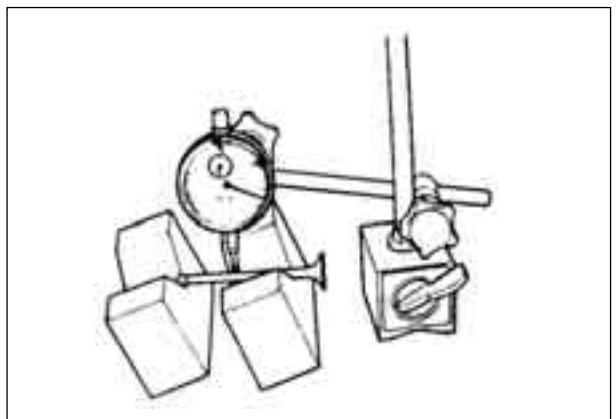
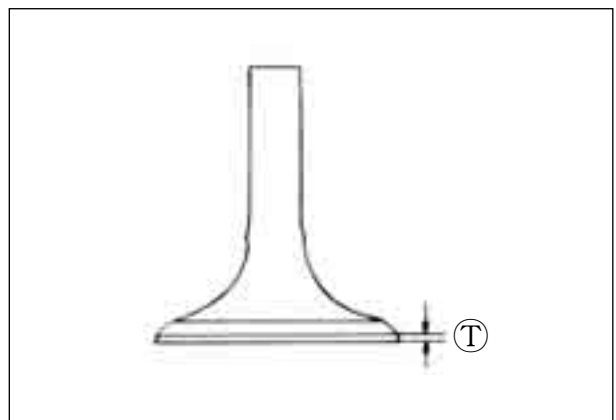

3-21 ENGINE

■ CAMSHAFT WEAR

Worn-down cams are often the cause of mistimed valve operation resulting in reduced output power.

The limit of cam wear is specified for both intake and exhaust cams in terms of cam height H , which is to be measured with a micrometer. Replace camshafts if found it worn down to the limit.

Cam height H	Service limit
Intake cam	34.170 mm
Exhaust cam	34.120 mm

 **Micrometer(25~50 mm) : 09900-20202**

● Tappet & shim wear

When measuring the valve clearance, the clearance should be within the standard range.

Valve clearance	Standard(When cold)
Intake valve	0.1~0.2 mm
Exhaust valve	0.2~0.3 mm

- Inspect the tappet for wear and scratch.
If modification or scratch is present, replace the tappet.
- The shim has various size.
Replace the thin shim to valve clearance is narrow, or the thick shim to valve clearance is wide as that shim thickness was installed with standard at present.
(Refer to page 7-25 · 26)

■ SHIM KIND

There are 41 kinds of shim which thickness is increased by each 0.025 mm from 1.20 mm to 2.20 mm.

● VALVE HEAD RADIAL RUNOUT

Place a dial gauge as shown and measure valve head radial runout.

If the service limit is exceeded, replace the valve.

Valve head radial runout	Service limit
	0.03 mm

 **Dial gauge : 09900-20606**
Magnetic stand : 09900-20701
V-block : 09900-21304

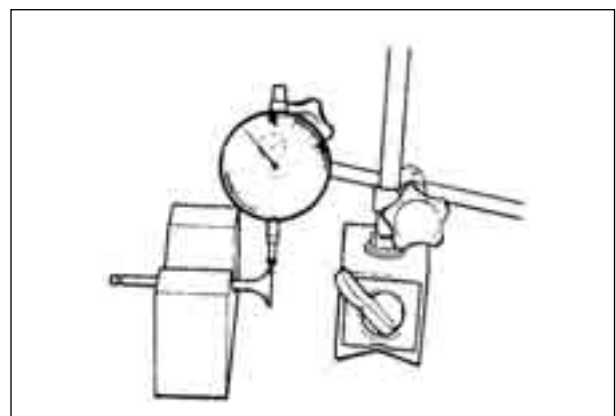
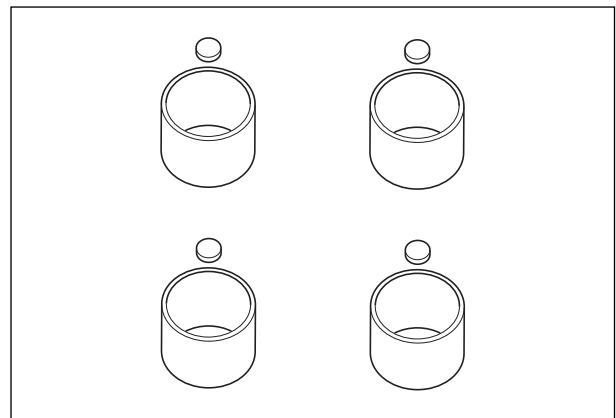
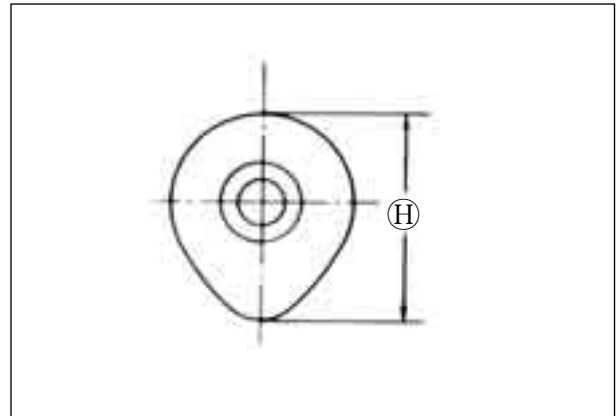

● VALVE GUIDE-VALVE STEM CLEARANCE

Measure the clearance in the valve guide-valve stem, by rigging up the dial gauge as shown. If the clearance is measured exceeds the limit specified below, then determine whether the valve or the guide should be replaced to reduce the clearance to within the standard range:

Valve guide-valve stem clearance	Standard
IN.	0.010~0.037 mm
EX.	0.030~0.057 mm

 Dial gauge : 09900-20606
Magnetic stand : 09900-20701

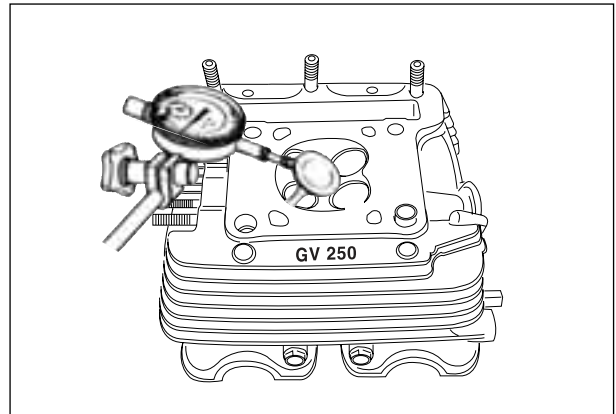

● VALVE STEM DIAMETER

Measure the valve stem outside diameter. If the diameter measured exceeds the standard, replace the valve.

Valve stem diameter	Standard
IN.	4.475~4.490 mm
EX.	4.455~4.470 mm

 Micrometer(0~25 mm) : 09900-20201

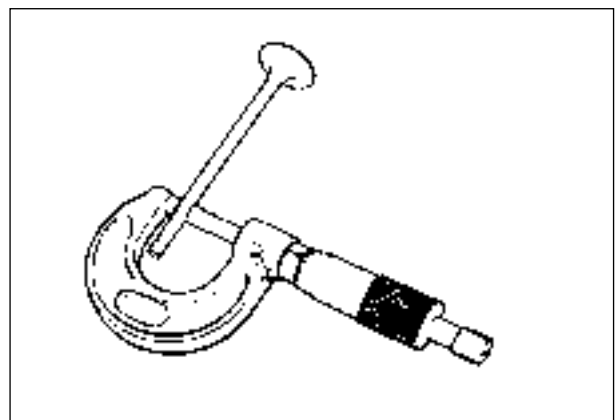

● VALVE GUIDE INSTALLATION

- Re-finish the valve guide holes in cylinder head with a 11.3 mm valve guide reamer ① and valve guide reamer handle ②.

 11.3 mm valve guide reamer : 09916-34561
Valve guide reamer handle : 09916-34542

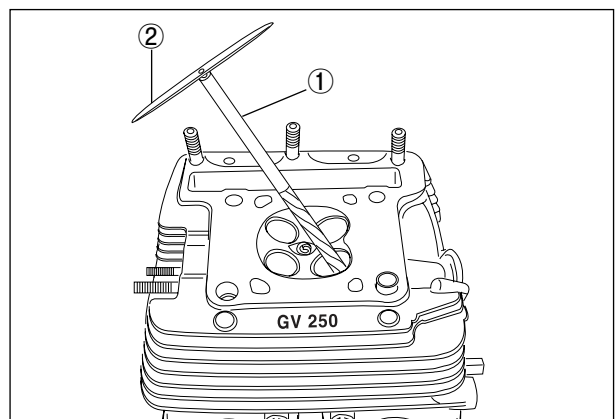

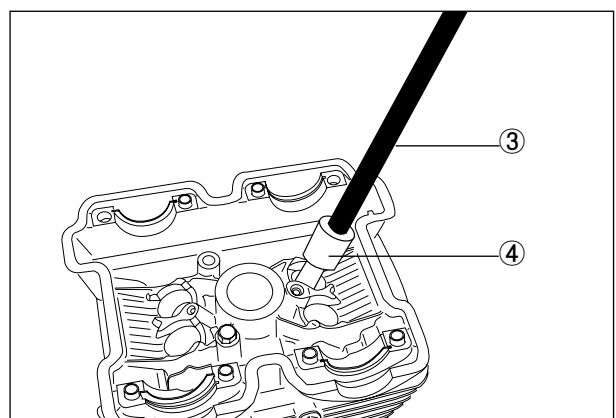

- Fit a ring to each valve guide. Be sure to use new rings and valve guides. Use of rings and valve guides removed in disassembly must be discarded.
- Lubricate each valve guide and drive the guide into the guide hole using the valve guide installer handle ③ and valve guide installer attachment ④.

 Valve guide installer and remover : 09916-44910
Valve guide installer attachment : 09916-44920





3-23 ENGINE

- After fitting all valve guides, re-finish their guiding bores with a 4.5 mm valve guide reamer  and valve guide reamer handle . Be sure to clean and oil the guides after reaming.

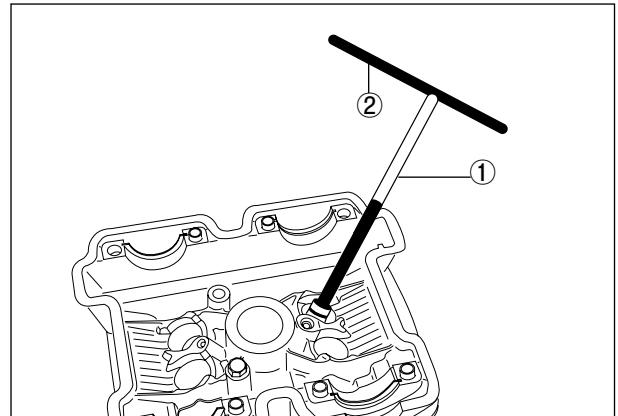
 **4.5 mm valve guide reamer : 09916-33210**
Valve guide reamer handle : 09916-34541



- Install valve spring lower seat . Be careful not to confuse the lower seat with the spring retainer .

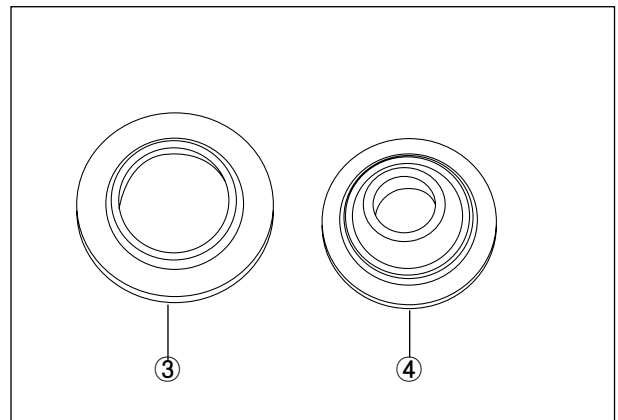

- Lubricate each seal, and drive them into position with the valve stem seal installer .

 **CAUTION**

Do not reuse the oil seals.

 **Valve guide installer and stem seal installer : 09916-44910**

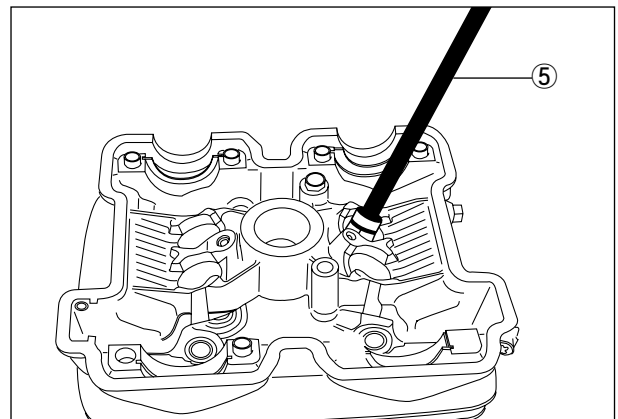

● VALVE SEAT WIDTH

- Coat the valve seat with prussian blue uniformly. Fit the valve and tap the coated seat with the valve face in a rotating manner, in order to obtain a clear impression of the seating contact. In this operation, use the valve lapper to hold the valve head.
- The ring-like dye impression left on the valve face must be continuous-without any break. In addition, the width of the dye ring, which is the visualized seat "width", must be within the specification.

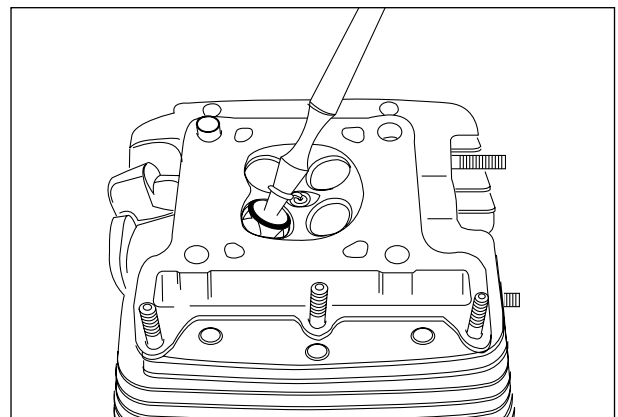

If either requirement is not met, correct the seat by servicing it as follows.

Valve seat width $\text{\textcircled{W}}$	Standard
	0.9~1.1 mm

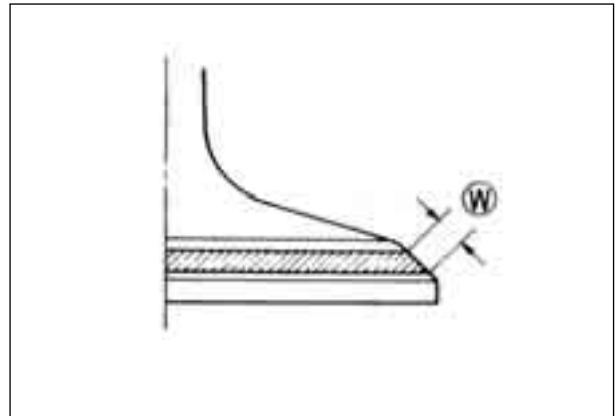

⦿ VALVE SEAT SERVICING

The valve seats for both intake and exhaust valves are angled to present two bevels, 15° and 45°.

 **Valve seat cutter set : 09916-21110**

Use only for 15° of intake side.

 **15° × 75° Valve seat cutter : 09916-24910**
Solid pilot (N-140-5.5) : 09916-24480

CAUTION

The valve seat contact area must be inspected after each cut.

1. Insert with a slight rotation, the solid pilot that gives a snug fit. The shoulder on the pilot should be about 10 mm from the valve guide.
2. Using the 45° cutter, descale and cleanup the seat with one or two turns.
3. Inspect the seat by the previous seat width measurement procedure. If the seat is pitted or burned, additional seat conditioning with the 45° cutter is required.

CAUTION

Cut the minimum amount necessary from the seat to prevent the possibility of the valve stem becoming too close to the rocker arm for correct valve contact angle.

If the contact area is too low or too narrow, use the 45° cutter to raise and widen the contact area. If the contact area is too high or too wide, use the 15° cutter to lower and narrow the contact area.

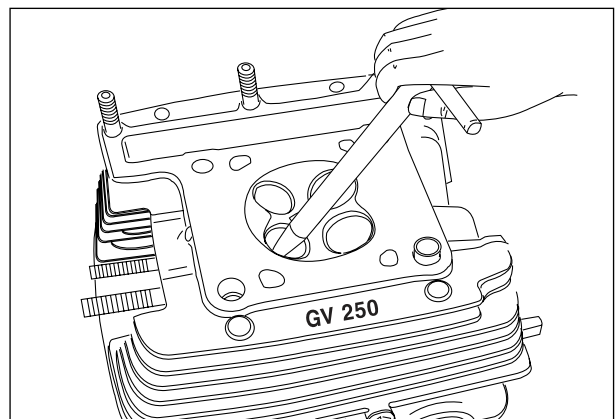
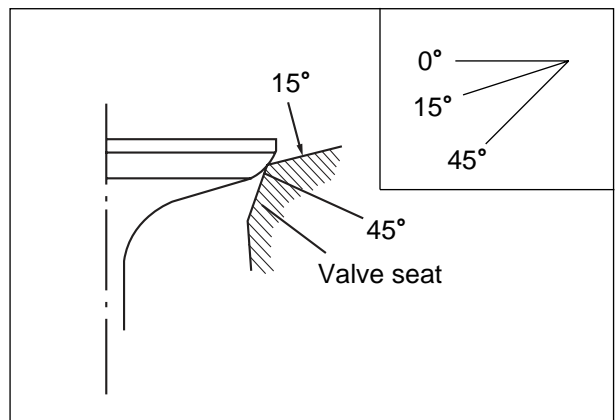

3-25 ENGINE

4. After the desired seat position and width is achieved, use be 45° cutter very lightly to clean up any burrs caused by the previous cutting operations. **DO NOT** use lapping compound after the final cut is made. The finished valve seat should have a velvety smooth finish and not a highly polished or shiny finish. This will provide a soft surface for the final seating of the valve which will occur during the first few seconds of engine operation.
5. Clean and assemble the head and valve components. Fill the intake and exhaust ports with gasoline to check for leaks. If any leaks occur, inspect the valve seat and face for burrs or other things that could prevent the valve from sealing.

⚠ WARNING

Always use extreme caution when handling gasoline.

⚠ CAUTION

Be sure to adjust the valve clearance after reassembling the engine.

⊙ VALVE SPRING

The force of the coil spring keeps the valve seat tight. A weakened spring results in reduced engine power output and often accounts for the chattering noise coming from the valve mechanism.

Check the valve springs for proper strength by measuring their free length and also by the force required to compress them. If the spring length is less than the service limit or if the force required to compress the spring does not fall within the specified range, replace both the inner and outer springs as a set.

Valve spring free length(IN. & EX.)	Service limit
	37.80 mm

🔧 TOOL Venier calipers : 09900-20101

Valve spring tension (IN. & EX.)	Standard
	12.1~13.9 kgf (at length 33.7 mm)

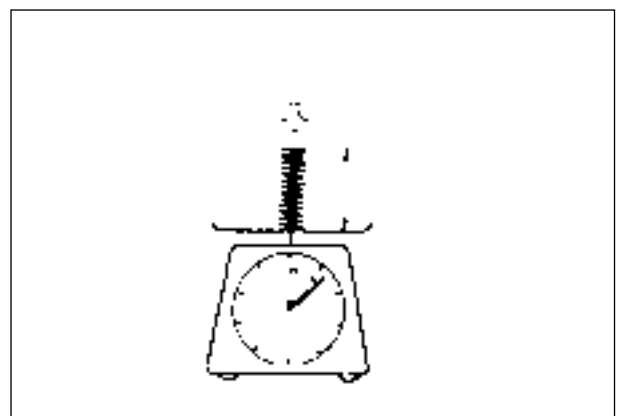
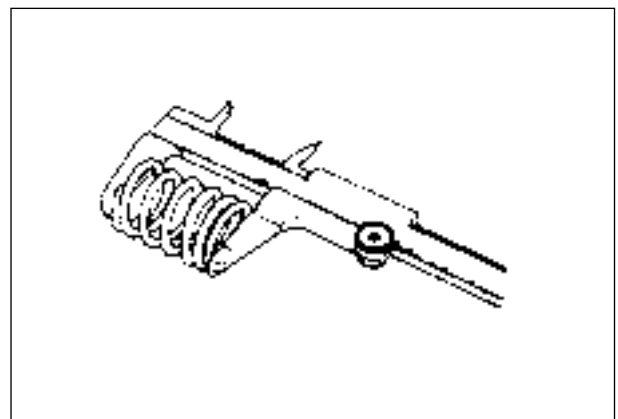

⦿ CYLINDER DISTORTION

Check the gasketed surface of the cylinder for distortion with a straightedge and thickness gauge, taking a clearance reading at several places as indicated. If the largest reading at any position of the straightedge exceeds the limit, replace the cylinder.

Cylinder distortion	Service limit
	0.05 mm

 Thickness gauge : 09900-20806



⦿ CYLINDER BORE

Measure the cylinder bore diameter at six places. If any one of the measurements exceeds the limit, overhaul the cylinder and replace the piston with an oversize, or replace the cylinder.

Cylinder bore	Standard	Service limit
	57.000~57.015 mm	57.080 mm

 Cylinder gauge set : 09900-20508

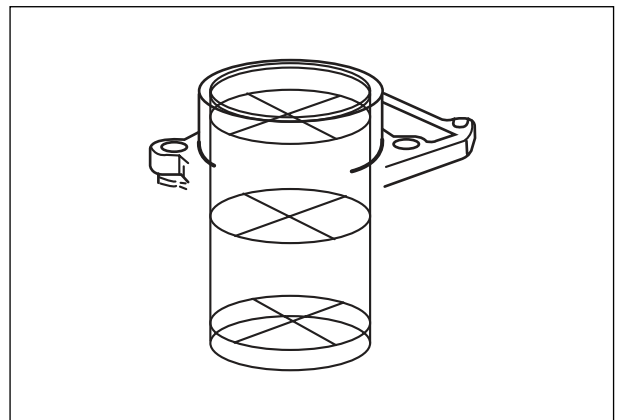

⦿ CAM CHAIN TENSION ADJUSTER

Check that the push rod slides smoothly with the lock shaft handle ① clockwise (↻).

If it does not slide smoothly, replace the cam chain tension adjuster with a new one.

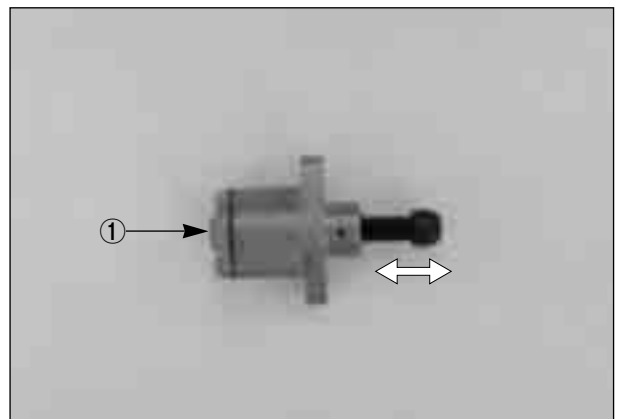

⦿ CAM CHAIN TENSIONER

Check the contacting surface of the cam chain tensioner. If it is worn or damaged, replace it with a new one.

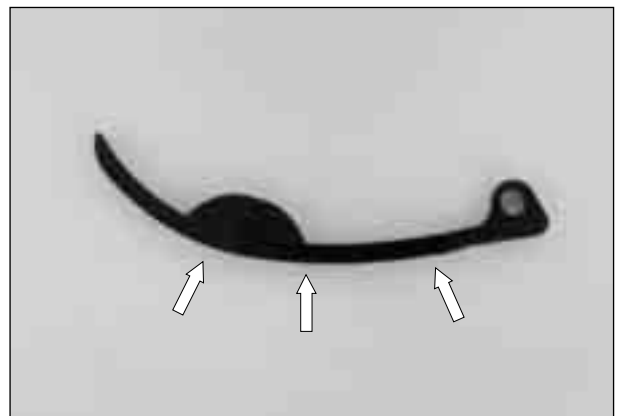

⦿ **CAM CHAIN AND CAM CHAIN GUIDE**

Check the cam chain for wear, damage and kinked or binding links. If any defects are found, replace it with a new one.

Check the cam chain guide for wear and damage. If it is found to be damaged, replace it with a new one.

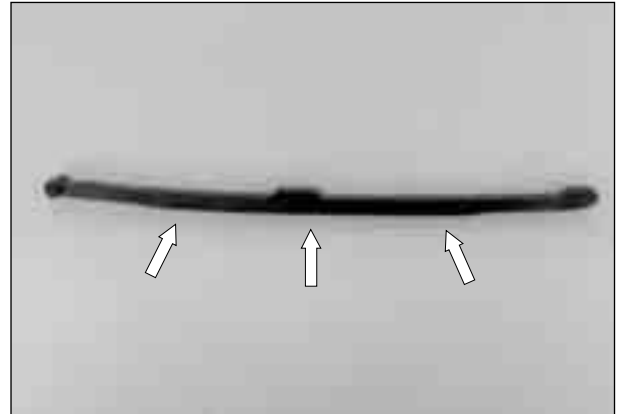



⦿ **PISTON DIAMETER INSPECTION**

Measure the outside diameter of piston in the direction perpendicular to the piston pin axis at the height from the skirt as shown in the illustration using a micrometer.

If the measurement is found less than the service limit, replace the piston.

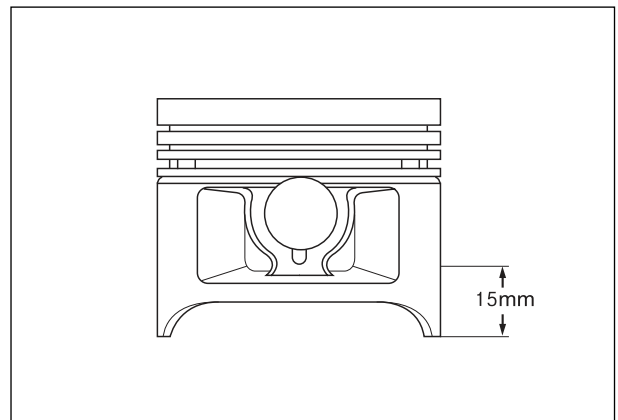
Piston diameter	Service limit
	56.880 mm
Piston oversize	0.5, 1.0 mm



 **Micrometer(50~75 mm) : 09900-20203**

⦿ **PISTON-TO-CYLINDER CLEARANCE**

To determine the piston-to-cylinder clearance, calculate the difference between the cylinder bore and outside diameter of the piston.

Piston-to-cylinder clearance	Standard	Service limit
	0.05~0.06 mm	0.120 mm

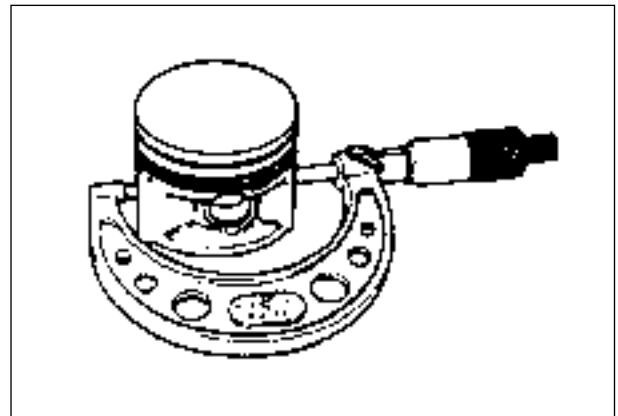

⦿ **PISTON PIN HOLE BORE**

Using a dial calipers, measure the piston pin hole bore both in the vertical and horizontal directions.

If the measurement exceeds the service limit, replace the piston.

Piston pin hole bore	Service limit
	15.030 mm

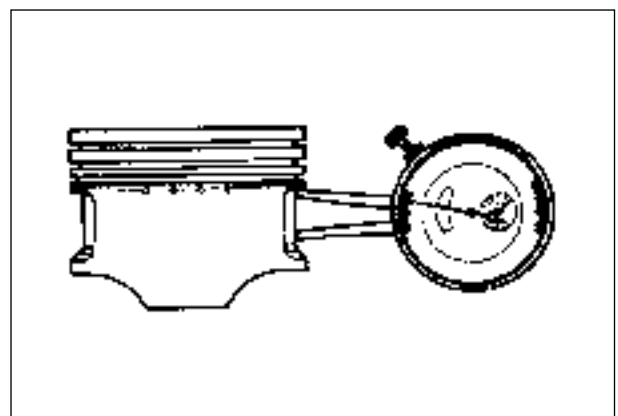

 **Dial calipers : 09900-20605**

⦿ PISTON PIN DIAMETER INSPECTION

Using a micrometer, measure the piston pin outside diameter at three position, both the ends and the center. If any of the measurements is founds less than the service limit, replace the pin.

Piston pin diameter	Service limit
	14.980 mm

 **Micrometer(0~25 mm) : 09900-20201**

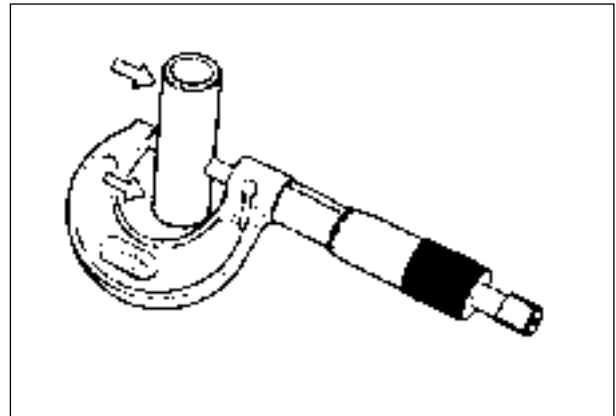

⦿ PISTON RING FREE END GAP INSPECTION

Before installing piston rings, measure the free end gap of each ring using vernier calipers. If the gap is less than the service limit, replace the ring.

Piston ring free end gap	Standard	Service limit
1st	7.2 mm	5.7 mm
2nd	5.8 mm	4.6 mm

 **Vernier calipers : 09900-20101**

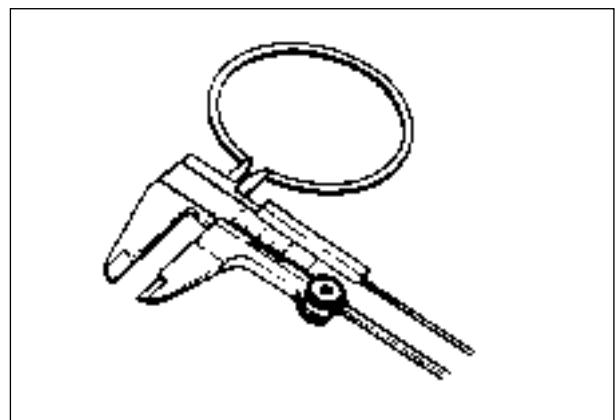

⦿ PISTON RING END GAP INSPECTION

Insert the piston ring squarely into the cylinder using the piston head.

Measure the end gap with a thickness gauge.

If the gap exceeds the service limit, replace the piston ring.

Piston ring end gap(Free condition)	Standard	Service limit
1st	0.20~0.32 mm	0.5 mm
2nd	0.20~0.32 mm	0.5 mm

 **Thickness gauge : 09900-20806**

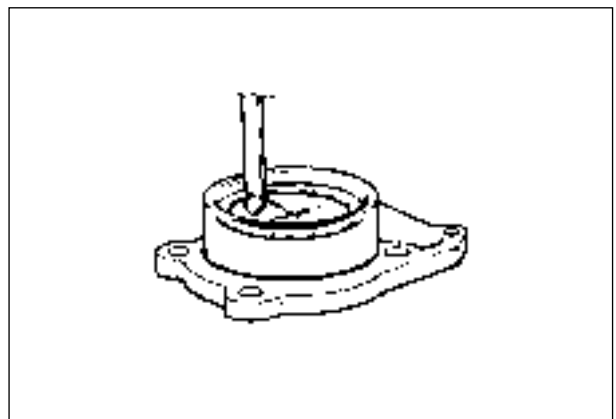

⦿ PISTON RING-TO-GROOVE CLEARANCE INSPECTION

Remove carbon deposit both from the piston ring and its groove.

Fit the piston ring into the groove. With the ring compressed and lifted up, measure the clearance on the bottom side of the ring using a thickness gauge.

Piston ring-groove clearance	Service limit
1st	0.180 mm
2nd	0.150 mm

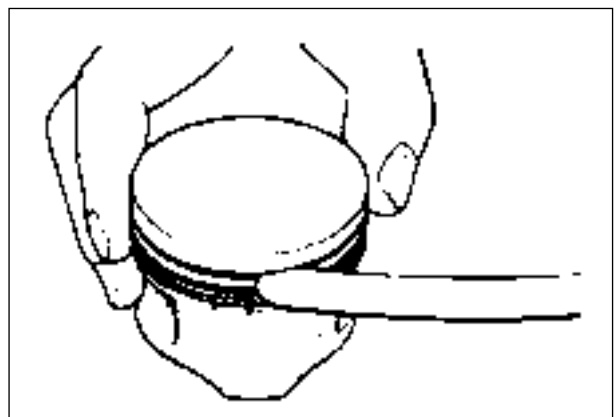

Piston ring-groove width	Standard
1st	1.01~1.03 mm
2nd	1.01~1.03 mm
Oil	2.01~2.03 mm

Piston ring thickness	Standard
1st	0.970~0.990 mm
2nd	0.970~0.990 mm

 **Thickness gauge : 09900-20806**
Micrometer(0~25 mm) : 09900-20201

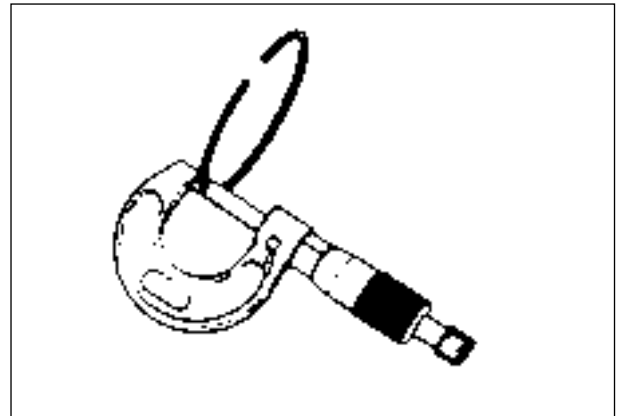

⊙ **OVERSIZE RINGS**

■ **Oversize piston ring**

The following two types of oversize piston ring are used. They bear the following identification numbers.

Oversize piston ring	1st	2nd
0.5 mm	05	05
1.0 mm	10	10

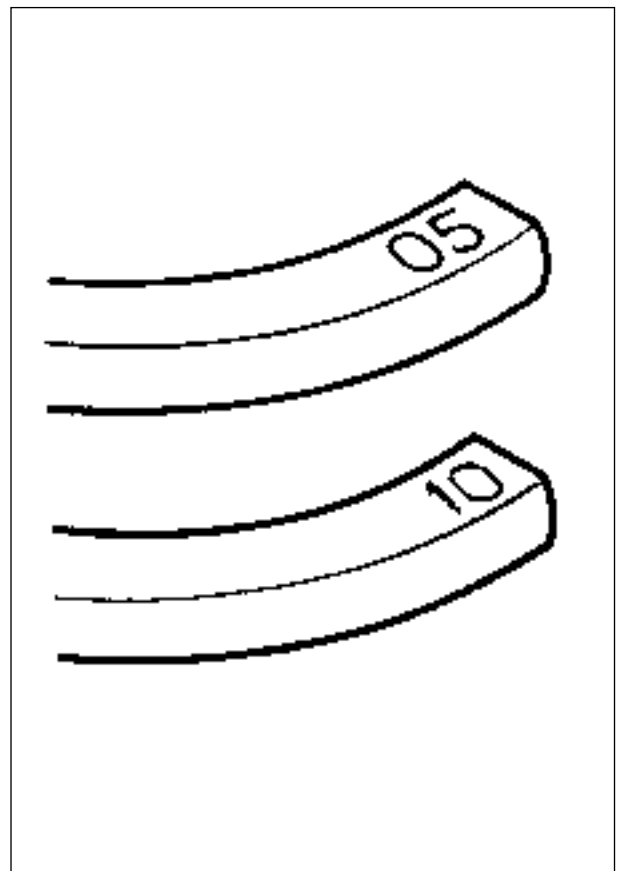

■ **Oversize oil ring**

The following two types of oversize oil ring are used. They bear the following identification marks.

Oversize oil ring	Color classification
0.5 mm	Painted red
1.0 mm	Painted yellow

⊙ **CONROD SMALL END INSIDE DIAMETER INSPECTION**

Using a dial calipers, measure the conrod small end inside diameter both in vertical and horizontal directions. If any of the measurements exceeds the service limit, replace the conrod.

Conrod small end inside diameter	Standard	Service limit
	15.006~15.014 mm	15.040 mm

 **Dial calipers : 09900-20605**

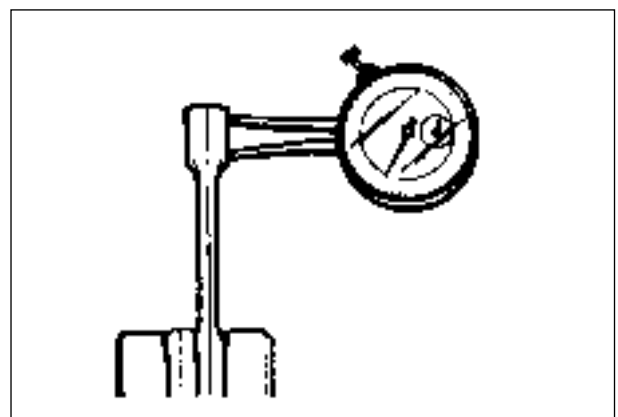

⦿ **CONROD DEFLECTION INSPECTION**

Move the small end sideways while holding the big end immovable in thrust direction.

Measure the amount of deflection.

Turn the conrod and see if it moves smoothly without play and noise.

This method can check the extent of wear on the parts of the conrod's big end.

Conrod deflection	Service limit
	3.0mm

-  **Magnetic stand : 09900-20701**
- Dial gauge : 09900-20606**
- V-block : 09900-21304**

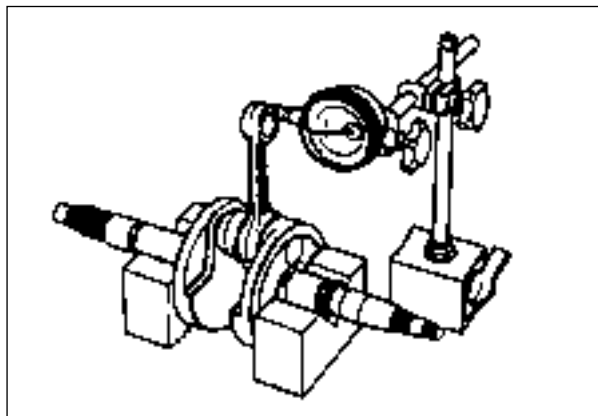

⦿ **CONROD BIG END SIDE CLEARANCE INSPECTION**

Using a thickness gauge, measure the side clearance at the conrod big end. If the measurement is out of standard value, measure the conrod big end and the crank pin widths individually to determine which one is to be replaced.

Conrod big end side clearance	Standard	Service limit
	0.40~0.85 mm	1.0 mm

-  **Thickness gauge : 09900-20806**



⦿ **CRANKSHAFT RUNOUT INSPECTION**

With the right and left crank journals supported with V-block, turn the crankshaft slowly. At this time, measure the crankshaft end runout using a dial gauge. If the runout exceeds the service limit, replace the crankshaft.

Crankshaft runout	Service limit
	0.05 mm

-  **Magnetic stand : 09900-20701**
- Dial gauge : 09900-20606**
- V-block : 09900-21304**

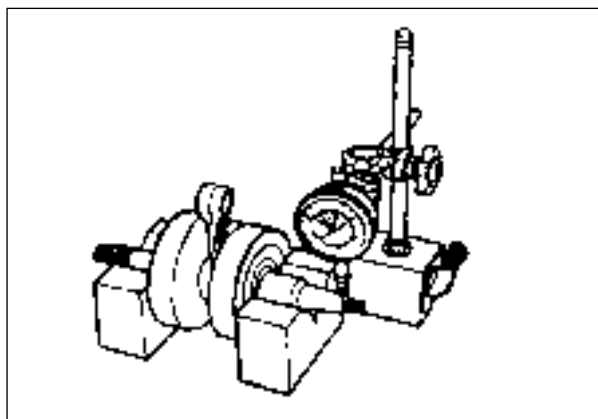

⦿ **CRANKSHAFT REASSEMBLY**

Measure the width between the webs referring to the figure below when rebuilding the crankshaft.

Width between webs	Standard
	72±0.1 mm

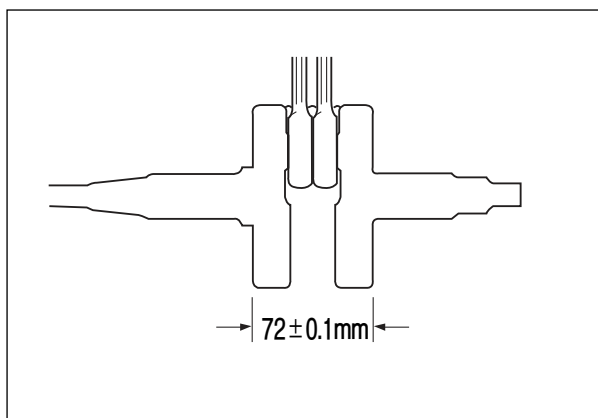

⦿ **MAGNETO COVER**

■ **MAGNETO INSPECTION**(Refer to page 5-4)

■ **DISASSEMBLY**

- Remove the stator ①.

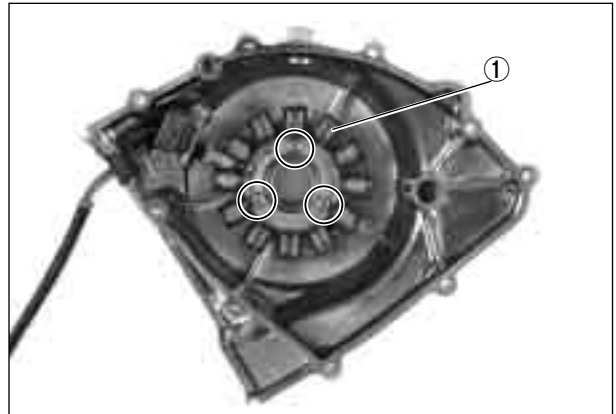

⦿ **STARTER CLUTCH**

Install the starter driven gear onto the starter clutch and turn the starter driven gear by hand(the gear turns in only one direction). The starter driven gear should turn smoothly. If excessive resistance is felt while turning the starter driven gear, inspect the starter clutch. Also, inspect the surface of the starter driven gear which contacts the starter clutch, for wear or damage. If any wear or damage is found, replace the defective part(-s).



■ **DISASSEMBLY**

- Hold the magneto rotor with the rotor holder and remove the starter clutch bolts.

 **Rotor holder : 09930-44510**



■ **REASSEMBLY**

- Apply a small quantity of THREAD LOCK “1324” to the starter clutch bolts and tighten them to the specified torque while holding the rotor holder.

 **Thread Lock “1324”**

 **Rotor holder : 09930-44510**

 **Starter clutch bolt**
: 15~20 N · m(1.5~2.0 kg · m)



⦿ STARTER DRIVEN GEAR

■ STARTER DRIVEN GEAR BUSHING

Install the starter driven gear bushing ① and gear ② onto the crankshaft and turn the starter driven gear by hand. Inspect the starter driven gear bushing for smooth rotation and any abnormal noise. If the bushing does not turn smoothly or there is any abnormal noise, replace it.

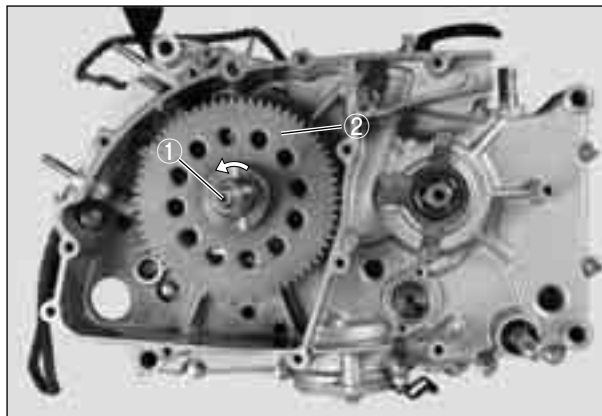

⦿ DISASSEMBLY

● Remove the bushing using the special tool.

 **Bearing remover(20~35 mm) : 09923-74510**



⦿ CLUTCH COVER

■ OIL FILTER REPLACEMENT(Refer to page 2-11)

■ DISASSEMBLY

● Remove the circlip and right crankshaft oil seal.

 **Oil seal remover : 09913-50121**



■ REASSEMBLY

● Drive in the oil seal using the special tool.

 **Bearing installer : 09913-75820**

● Install the circlip.



3-33 ENGINE

⊙ CLUTCH DRIVE PLATES

Measure the thickness and claw width of the clutch drive plates using vernier calipers. If a clutch drive plate is not within the service limit, replace the clutch plates as a set.

Clutch drive plate thickness	Standard	Service limit
	2.9~3.1 mm	2.6 mm

 Vernier calipers : 09900-20101

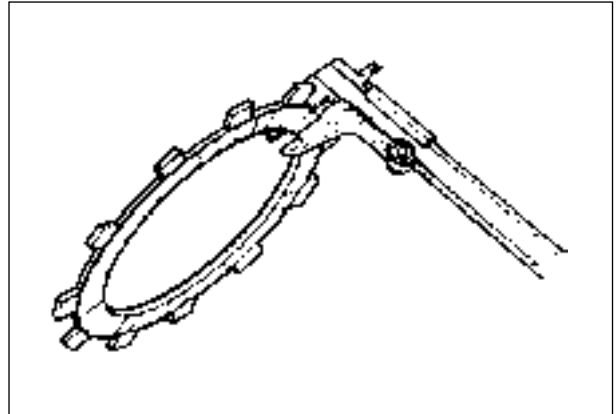

Clutch drive plate claw width	Standard	Service limit
	11.8~12.0 mm	11.0 mm

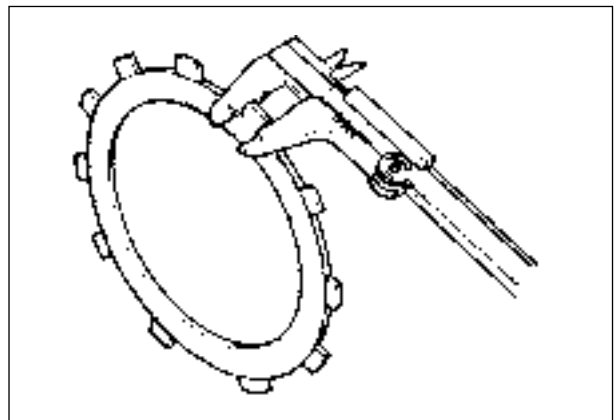

⊙ CLUTCH DRIVEN PLATES

Measure each clutch driven plates for distortion using the thickness gauge. If a clutch driven plate is not within the service limit, replace the clutch plates as a set.

Clutch driven plate distortion	Service limit
	0.1 mm

 Thickness gauge : 09900-20806

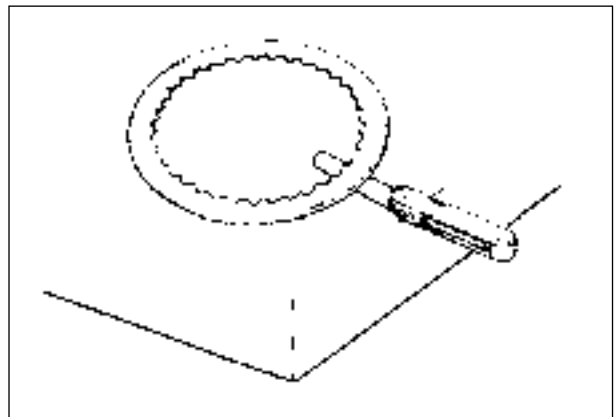

⊙ CLUTCH SPRING FREE LENGTH

Measure the free length of each clutch spring using vernier calipers. If any spring is not within the service limit, replace all of the spring.

Clutch spring free length	Service limit
	36.2 mm

 Vernier calipers : 09900-20101

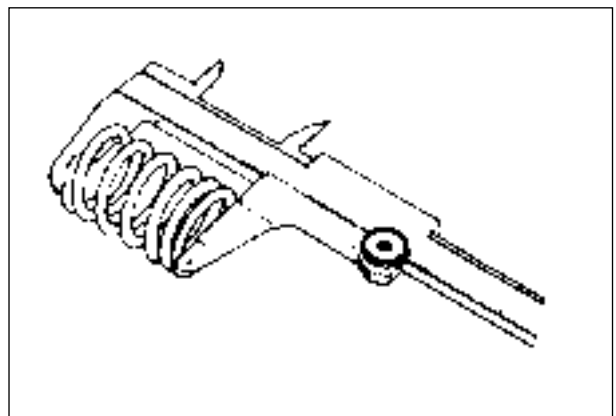

⦿ CLUTCH RELEASE BEARING

Inspect the clutch release bearing for any abnormality, especially cracks. When removing the bearing from the clutch, decide whether it can be reused or if it should be replaced.

Smooth engagement and disengagement of the clutch depends on the condition of this bearing.

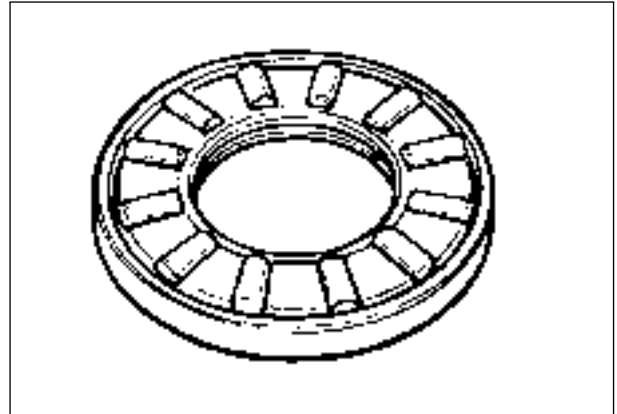
**⦿ PRIMARY DRIVEN GEAR**

Inspect the primary driven gear bearing for any damage. If any abnormal condition are found, replace the primary driven gear.

**⦿ OIL PUMP**

Turn the oil pump shaft and check that rotation is smooth. If any abnormal condition is found, replace the oil pump with new one.

**⦿ GEARSHIFT SHAFT**

Disassemble and reassemble the gearshift shaft as shown in right picture.



⊙ TRANSMISSION

■ INSPECTION

★ GEAR-SHIFTING FORK

Using a thickness gauge, check the clearance between in the groove of its gear and shifting fork.

The clearance for each of the three shifting forks plays an important role in the smoothness and positiveness of shifting action.

If the clearance checked is noted to exceed the limit specified, replace the fork or its gear, or both.

Shift fork-groove clearance	Standard	Service limit
	0.10~0.30 mm	0.5 mm

 Thickness gauge : 09900-20806
Vernier calipers : 09900-20101

Shift fork groove width	Standard
NO.1 & NO.2	5.0~5.1 mm
NO.3	5.0~5.1 mm

Shift fork thickness	Standard
NO.1 & NO.2	4.8~4.9 mm
NO.3	4.8~4.9 mm

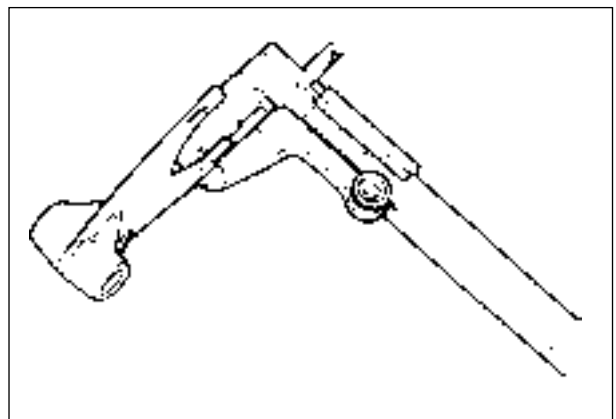
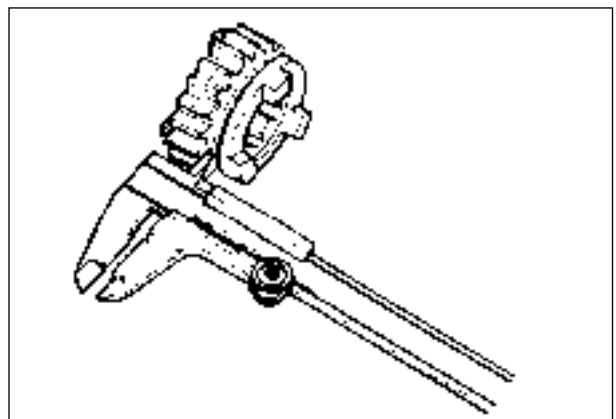
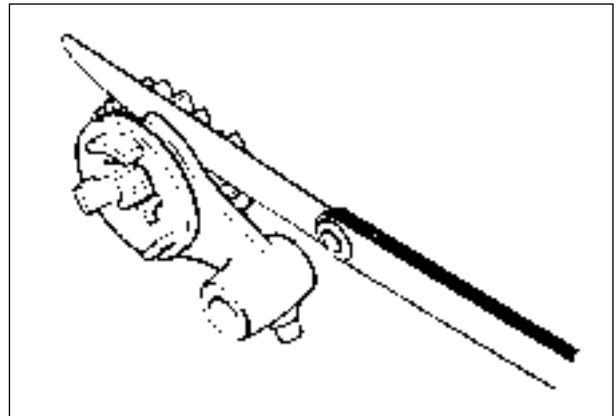

■ REASSEMBLY

Assemble the countershaft and drivenshaft in the reverse order of disassembly. Pay attention to following points :

NOTE:

Always use new circlips.

NOTE:

Before installing the gears, coat lightly engine oil to the drivenshaft and countershaft.

⚠ CAUTION

- ❖ Never reuse a circlip. After a circlip has been removed from a shaft, it should be discarded and a new circlip must be installed.
- ❖ When installing a new circlip, care must be taken not to expand the end gap larger than required to slip the circlip over the shaft.
- ❖ After installing a circlip, always ensure that it is completely seated in its groove and securely fitted.

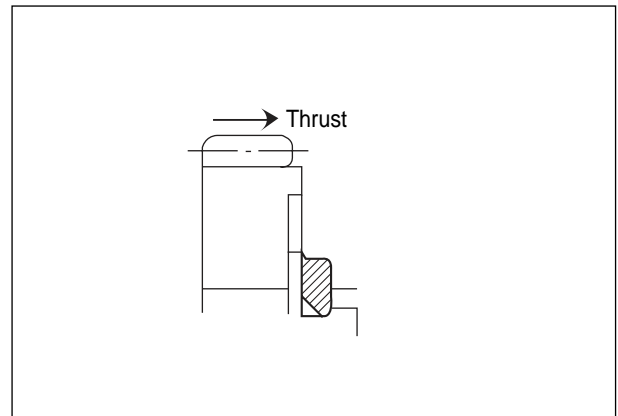

- When installing a new circlip, pay attention to the direction of the circlip. Fit it to the side where the thrust is as shown in figure.

■ TRANSMISSION GEARS AND RELATED PARTS

Thickness for washers, circlips and spacers

- Ⓐ 1.0mm Ⓓ 1.0mm
- Ⓑ 1.2mm Ⓔ 1.0mm
- Ⓒ 0.5mm

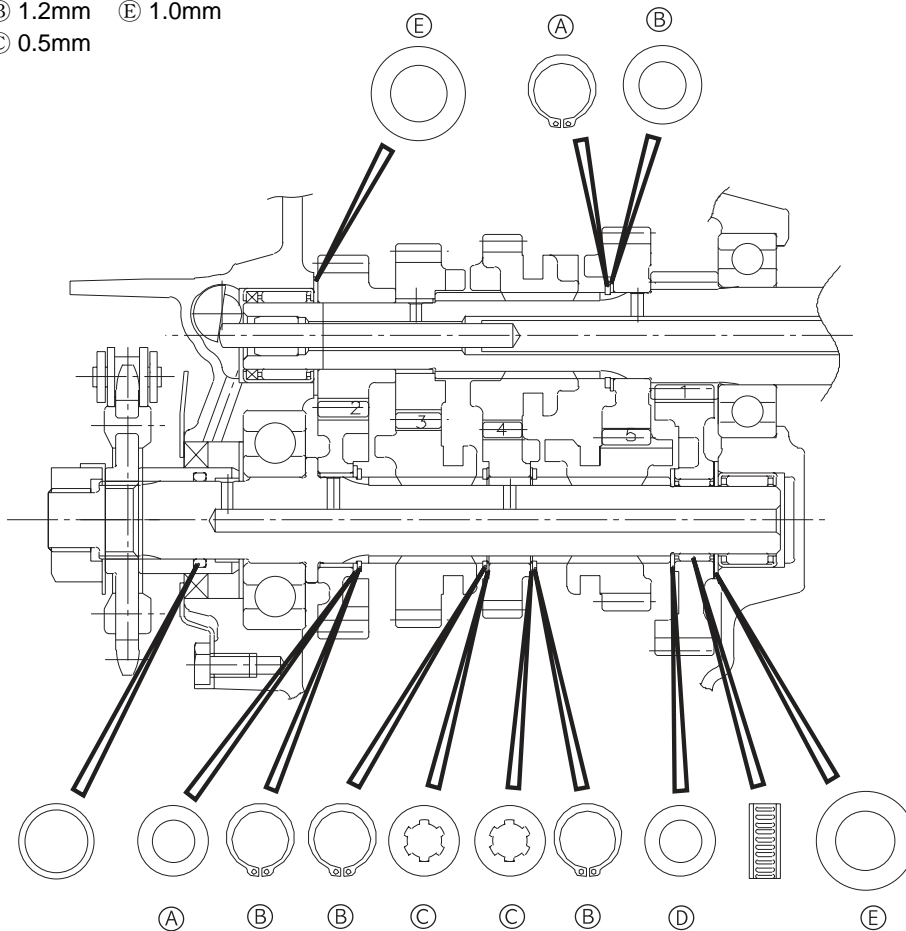

⦿ **CRANKCASE**

■ **BEARING INSPECTION**

Rotate the bearing inner race by finger to inspect for abnormal play, noise and smooth rotation while the bearings are in the crankcase.

Replace the bearing in the following procedure if there is anything unusual.

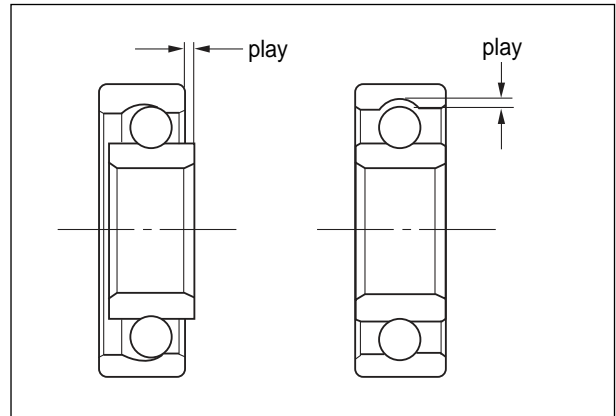

■ **DISASSEMBLY**

★ **RIGHT CRANKCASE BEARING**

- Remove the bearing retainer.



- Remove the bearings ① and ②.

- 🔧 **Bearing remover(17 mm) : 09923-73210**
Bearing remover(20~35 mm) : 09923-74510

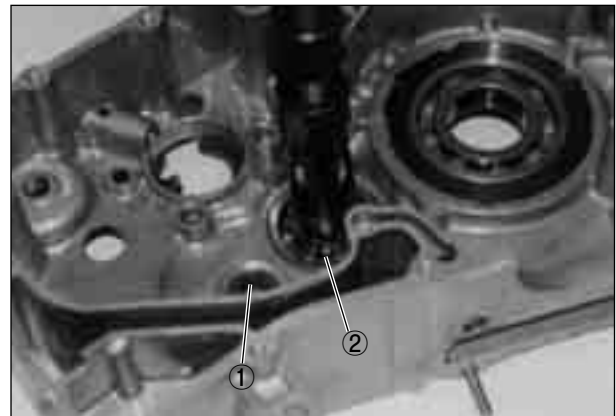

- Remove the bearing ③.

- 🔧 **Bearing installer : 09913-76010**

⚠ **CAUTION**

The removed bearing should be replace with a new one.

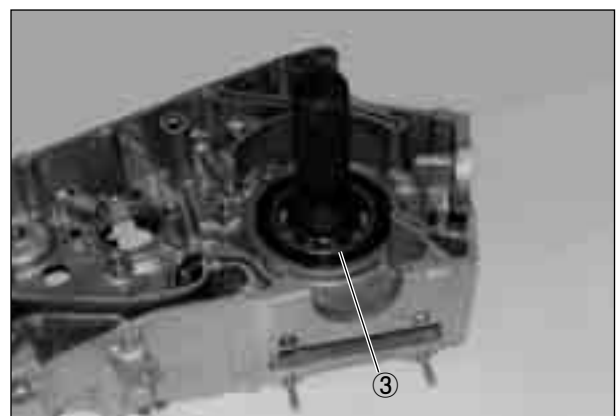

★ LEFT CRANKCASE BEARING

- Remove the oil seals ① and ②.

 Oil seal remover : 09913-50121

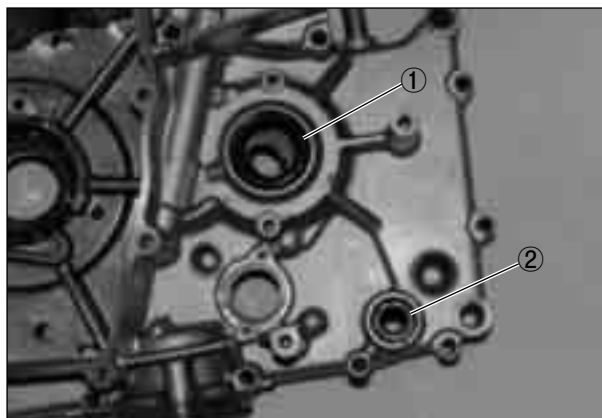

- Remove the bearing retainer.



- Remove the bearings ④, ⑤ and ⑥.

 Bearing remover(17 mm) : 09923-73210
 Bearing remover(20~35 mm) : 09923-74510

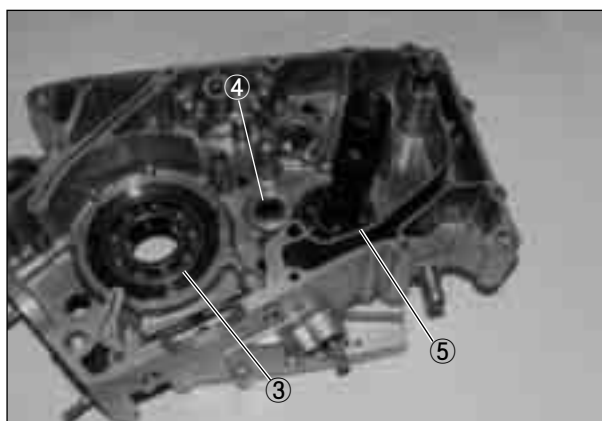

■ REASSEMBLY

Assemble the crankcase in the reverse order of disassembly.

Pay attention to the following points.

★ RIGHT CRANKCASE BEARING

- Drive in the bearings ⑦, ⑧ and ⑨.

 Bearing installer : 09913-70122
 Bearing installer : 09913-76010

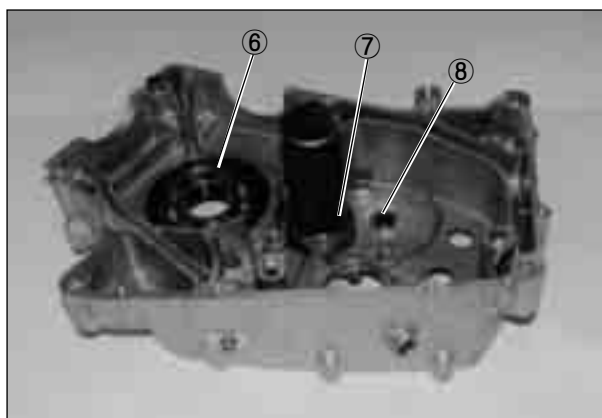

3-39 ENGINE

★ LEFT CRANKCASE BEARING

- Drive in the bearings 1, 2 and 3.

 **Bearing installer : 09913-70122**
Bearing installer : 09913-76010

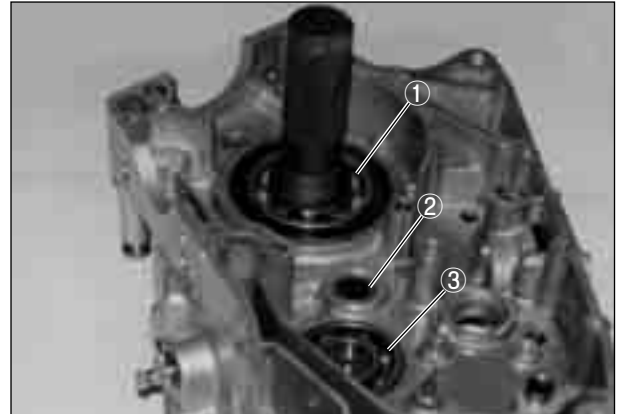

- Install the oil seals 4 and 5.
- Apply SUPER GREASE "A" on the lip of oil seal.

 **SUPER GREASE "A"**

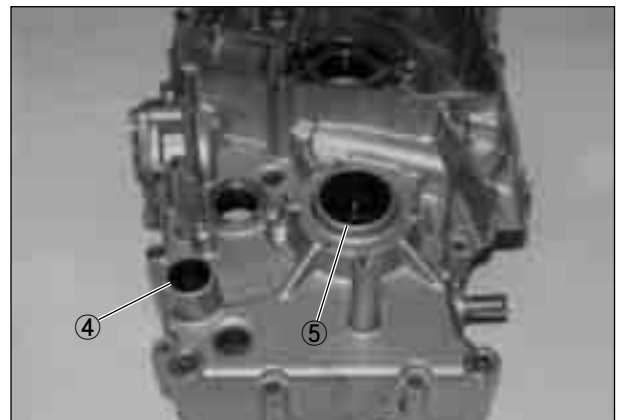

ENGINE REASSEMBLY

The engine reassembly can be performed in the reverse order of disassembly procedures. However, the following points must be observed in the reassembly operation.

CAUTION

Make sure to coat the rotating and sliding sections with engine oil.

⊙ CRANKSHAFT

- Using the special tool, press in the crankshaft into the left crankcase.

 **Crankshaft installer : 09910-32812**
Conrod holder : 09910-20115

CAUTION

Never fit the crankshaft into crankcase by striking it with a plastic hammer.
Always use the special tool, otherwise crankshaft alignment accuracy will be affected.



⊙ TRANSMISSION

- Install the transmission.



⊙ GEARSHIFT CAM AND GEARSHIFT FORKS

- Install the gearshift NO.1 ①, NO.2 ②, and NO.3 ③.
- Install the gearshift cam ④, and gearshift fork shaft ⑤, ⑥.
- Install the oil pump idle gear shaft ⑦.

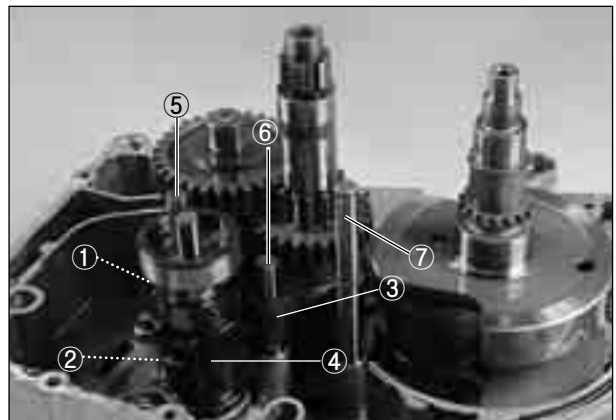

- Install the dowel pins ⑧.
- Before assembling the crankcase, apply the engine oil to each gears and bearings.



- Apply BOND “1215” to the right crankcase.

 BOND “1215”

CAUTION

- ❖ Application of BOND “1215” must be performed within a short period of time.
- ❖ Take extreme care not to let BOND “1215” enter into the oil hole or bearing.

3-41 ENGINE

- Install the crankcase.
- Install the crankcase bolts.

 **Crankcase bolt**
: 8~12 N · m(0.8~1.2 kg · m)

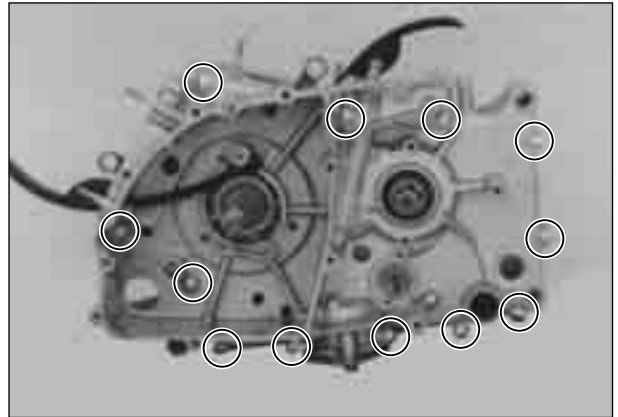

NOTE :

- ❖ *After the crankcase bolts have been tightened, make sure that the crankshaft, countershaft and driveshaft rotate smoothly.*
- ❖ *If these shafts do not rotate smoothly, try to free it by tapping with a plastic hammer.*

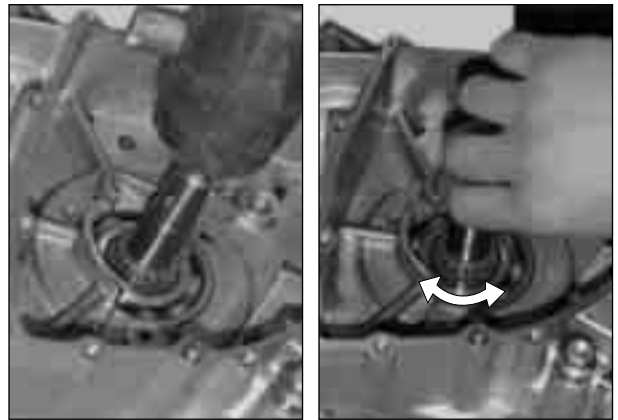

- Apply the SUPER GREASE “A” to the driveshaft O-ring and oil seal lip.
- Install the driveshaft spacer.

 **SUPER GREASE “A”**

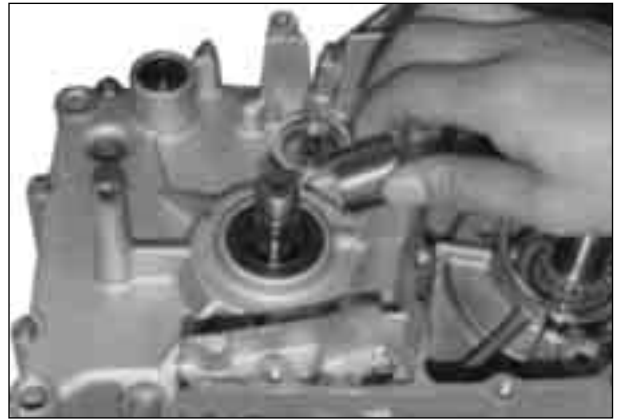

- Install the oil seal retainer.



■ GEARSHIFT CAM DRIVEN GEAR

- When installing the gearshift into the cam driven gear, the big shoulder Ⓐ face toward outside as shown in figure.
- Install the cam guide and pawl lifter.
When installed, apply the THREAD LOCK “1324” to the securing screw.

 **THREAD LOCK “1324”**

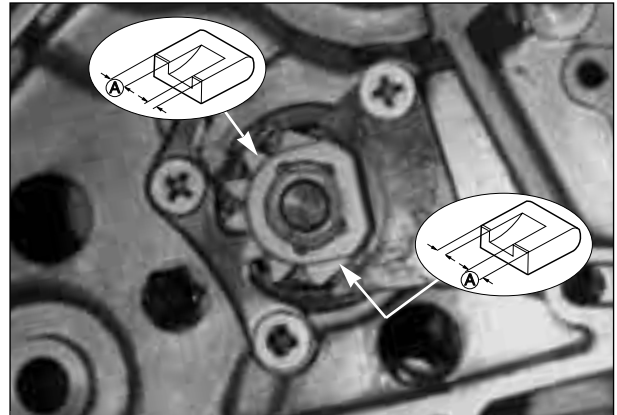

■ GEARSHIFT SHAFT

Install the gear shifting shaft. Match the center teeth of the gear on the shifting shaft with the center teeth on the shifting driven gear as shown.

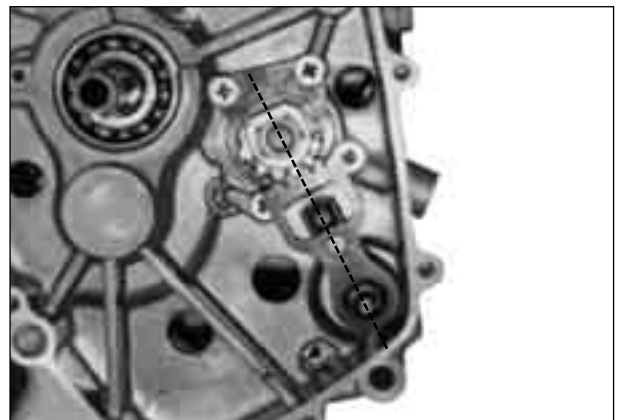

▲ CAUTION

After the cam driven gear, cam guide, gear shift shaft and neutral cam stopper have been fitted, confirm that gear change is normal while turning, the countshaft and driveshaft. If gear change is not obtained, it means that assembly of gears or installation of gear shifting fork is incorrect. In this case, disassemble and trace the mistake.

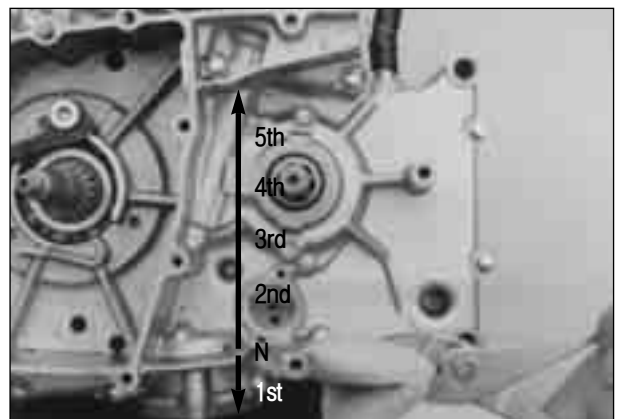

● OIL PUMP

- Before installing the oil pump, apply the engine oil to the contact face of case, outer rotor, inner rotor and shaft.
- Apply a small quantity THREAD LOCK “1324” to the oil pump securing screws.

 **THREAD LOCK “1324”**

- Tighten the oil pump securing screws.

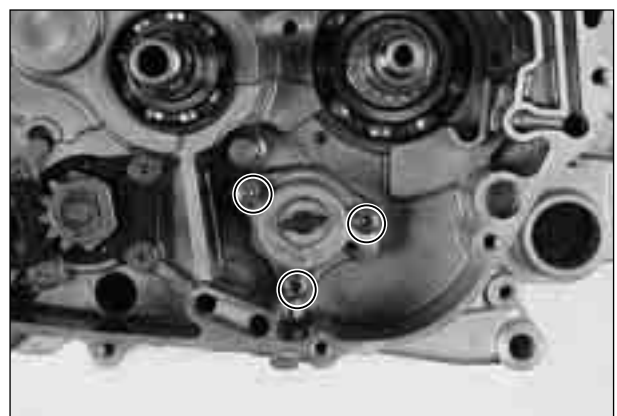

⊙ **PRIMARY DRIVE GEAR**

- Put in the oil pump driven gear, and install the circlip.



⚠ **CAUTION**

When installing the oil pump to the crankcase, turn the pump gear and check that rotation is smooth by the hand.



⊙ **CAM CHAIN TENSIONER**

- Install the washer ① and cam chain tensioner ②, tighten the cam chain tensioner bolt.

- 🔧 **Cam chain tensioner bolt**
: 6~8 N · m(0.6~0.8 kg · m)



- Install the cam chain ③ and key.



- Install the primary drive gear and NO.2 gear to the crankshaft, put in the key to the key groove.

CAUTION

When installing the NO.2 gear, install so that the mark on the gear align the key groove as shown in figure.

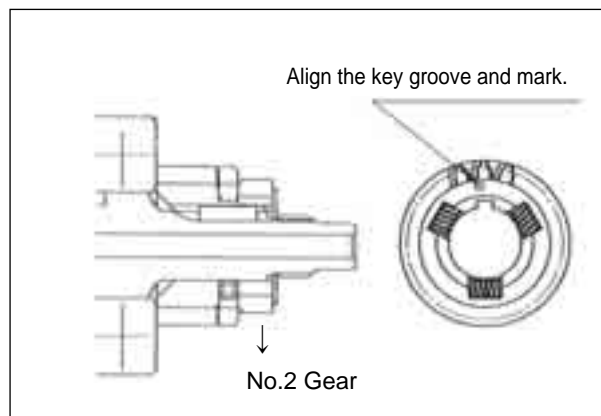

CAUTION

Pay attention to the two washer to lower end of the primary drive gear nut in times of assemblage.



- With the magneto rotor held immovable using special tool, tighten the primary drive gear nut.



Conrod holder : 09910-20115



Primary drive gear nut

: 40~60 N · m(4.0~6.0 kg · m)



⊙ PRIMARY DIRVEN GEAR

NOTE:

Apply engine oil to the inside surface of the primary driven gear bearing.

- Install the primary driven gear assembly.

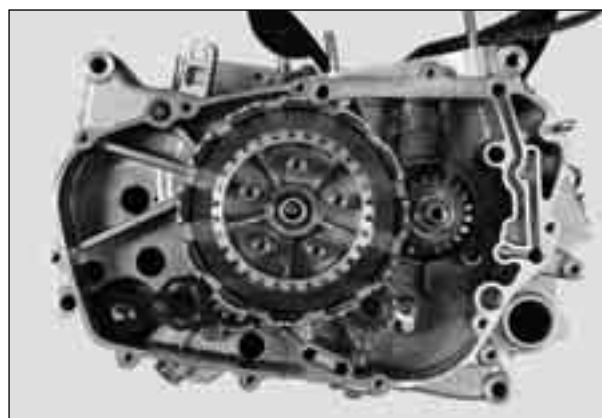

CLUTCH

- Install the clutch sleeve hub ①, lock washer ② and clutch sleeve hub nut.



- Install the clutch sleeve hub nut, and tighten it to the specified torque using the special tool.

 **Clutch sleeve hub holder : 09920-53710**

 **Clutch sleeve hub nut**
: 30~50 N · m(3.0~5.0 kg · m)

- Bend the lock washer securely.



- Install the clutch drive plates and driven plates.

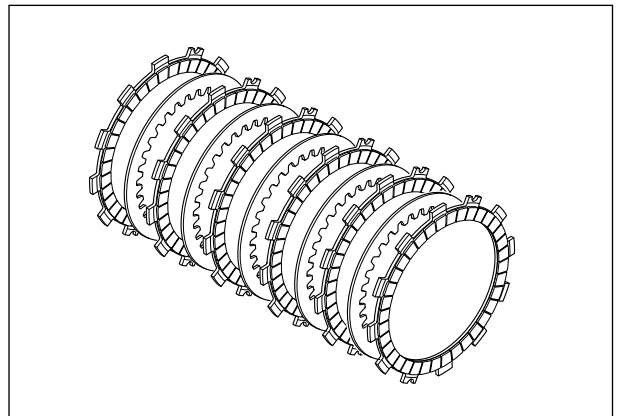

- Install the clutch release rack ①, bearing ② and washer ③.

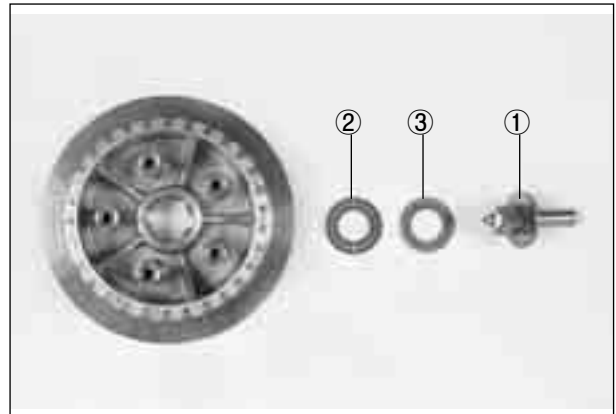

- Install the clutch pressure plate ④, clutch springs and clutch spring mounting bolts.
- Hold the primary drive gear nut and tighten the clutch spring mounting bolts in a crisscross pattern.

NOTE:

Make sure that the clutch pressure plate is installed correctly.

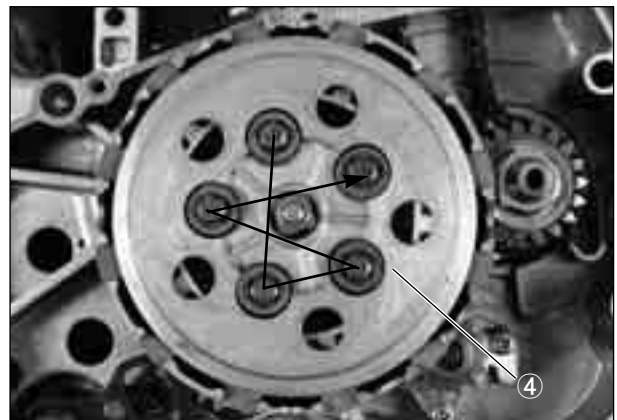

CLUTCH COVER

- Install the two dowel pins and new gasket ⑤.
- Apply engine oil to each gears, bearings and clutch plates.

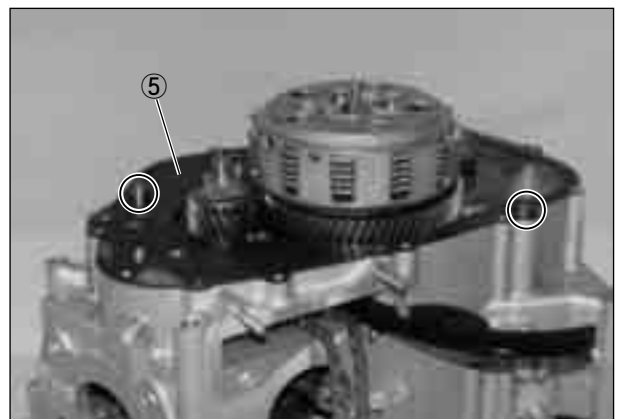

- Tighten the clutch cover bolts securely.

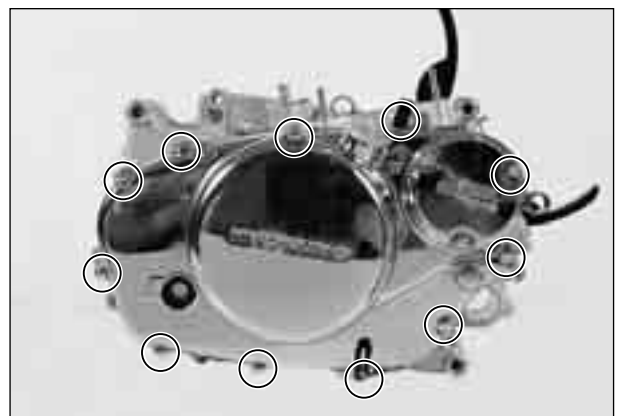

● Install the clutch release arm as following:

- ① Turn the clutch release shaft toward(This time, mark on the shaft align outside contact line the stopper screw) the right.
- ② Install that the cable connecting center line of the clutch release arm align matching mark rightside of the case as shown the right figure.

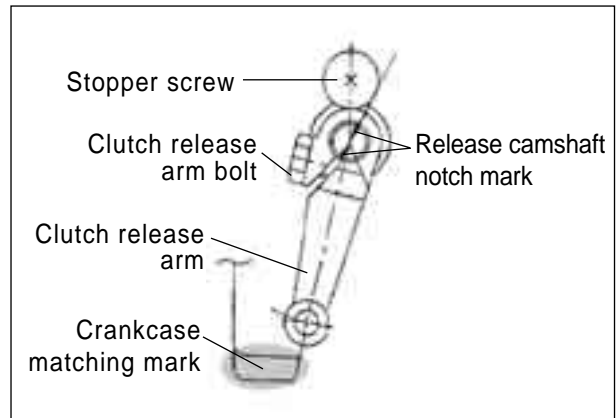

⊙ **NEUTRAL CAM STOPPER**

- Put in the neutral cam stopper, spring and washer, tighten the cam stopper plug to the specified torque.

 **Cam stopper plug**
: 20~25 N · m(2.0~2.5 kg · m)

⊙ **OIL DRAIN PLUG**

- Tighten the oil drain plug to the specified torque.

 **Engine oil drain plug**
: 18~20 N · m(1.8~2.0 kg · m)

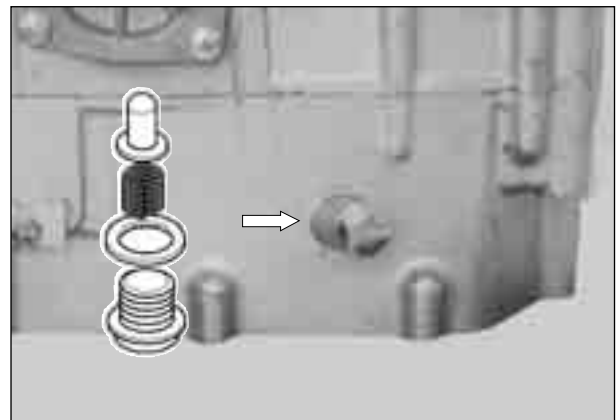

⊙ **STATOR**

- Apply a small quantity of THREAD LOCK “1324” to the threaded parts of screws.

 **THREAD LOCK “1324”**

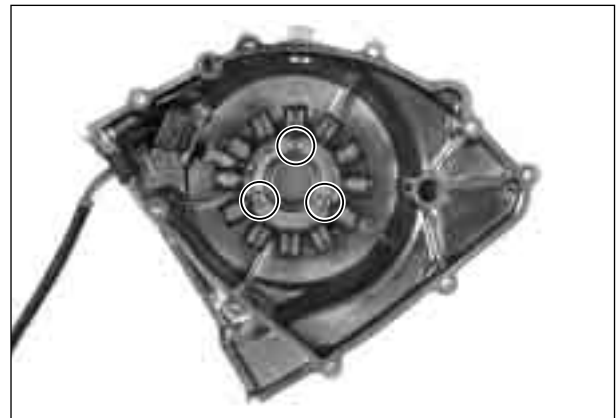

⊙ **STARTER CLUTCH**

- When installing the starter clutch and rotor, apply the THREAD LOCK “1324” to the bolts and tighten to the specified torque.

 **THREAD LOCK “1324”**

 **Starter clutch bolt**
: 15~20 N · m(1.5~2.0 kg · m)



⊙ MAGNETO ROTOR

- Fit the key in the key slot on the crankshaft.
- With the magneto rotor install the starter clutch, it install the crankshaft.
- Apply a small quantity of THREAD LOCK “1324” to the threaded parts of crankshaft.

 **THREAD LOCK “1324”**



- Tighten the magneto rotor nut to the specified torque.

 **Conrod holder : 09910-20115**

 **Magneto rotor nut**
: 50~60 N · m(5.0~6.0 kg · m)



⊙ STARTER IDLE GEAR AND MOTOR

- Install the starter idle gear, shaft and spacer.



- Install the starter motor.



⦿ **MAGNETO COVER**

- Install the new gasket and dowel pin.
- Apply oil to the each gears, bearing and starter clutch.

- Install the magneto cover and tighten the magneto cover bolts.

🔧 Magneto cover bolt
: 8~12 N · m(0.8~1.2 kg · m)

⦿ **PISTON RING**

- Install the piston ring in order of oil ring, 2nd ring and 1st ring at first at the front cylinder.

⚠ CAUTION

Be careful not to cause scratch on the piston when inserting the piston ring to the piston. Also, do not expand the piston ring more than necessary as the ring can break.

- When all the piston rings have been assembled, check that each can turn smoothly.
- To minimize compression and oil leaks, locate each piston ring end gap in the position as shown in the right illustration
 - ① 2nd ring / side rail(Upper side)
 - ② Side rail(Lower side)
 - ③ 1st ring / spacer

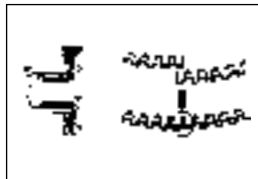

⦿ **PISTON**

- Apply the MOLY PASTE to the piston pin.

🔧 MOLY PASTE

- When installing the piston, turn the mark (A) on the piston head to exhaust side.
- After the piston pin has been inserted through the conrod, install the circlip (1).

⚠ CAUTION

Replace the circlip with a new one. Place a piece of rag under the piston when installing the circlip to prevent it from falling into the crankcase.

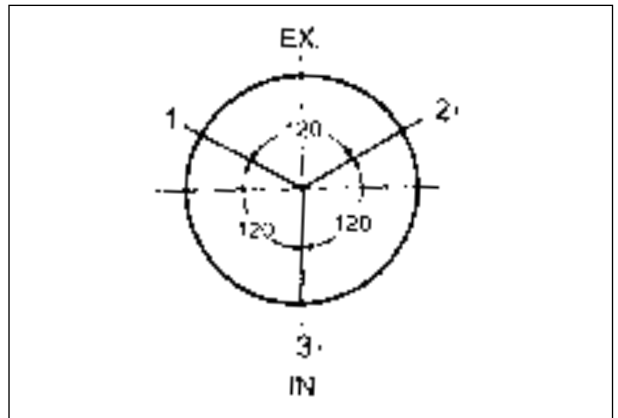
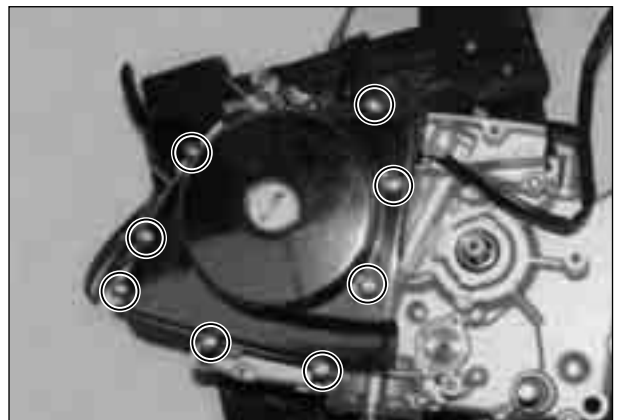

⊙ CYLINDER

- Apply BOND "1215" to the parting line of crankcase.

BOND "1215"

- Place the dowel pin ① and new gasket on the crankcase.

CAUTION

Make sure to replace the gasket with a new one.

- Apply the engine oil to the conrod big end, piston and the piston rings.
- Coat the cylinder wall with oil.
- Install the cylinder.

This cylinder is different from the front and rear. With the cam chain groove of cylinder face the left side, it is the front cylinder when the cam chain tension adjuster be existed at the back.

⊙ VALVE AND SPRING

- Insert the valve, with their stems coated with MOLY PASTE.
Apply the oil to the lip of the stem seal.

MOLY PASTE

- The narrow pitch side of each spring face to the head when the valve spring install. The pitch of inside spring and outside spring is changed. The pitch of spring is decreased from the upper side to the lower side.

-  Valve spring compressor : 09916-14510
Valve spring compressor attachment : 09916H35C00

⊙ CYLINDER HEAD

- Put in the valve spring and retainer, install the cotter with compressed the spring by using the valve spring compressor.

CAUTION

After installed the valve cotter, tap the valve stem end by using the plastic hammer at 2~3 times for assembly of the valve and cotter.

- Fit the cylinder head and tighten the stud bolts.

CAUTION

Pay caution to prevent the cam chain from dropping into the crankcase.

-  Cylinder head bolt : 21~25 N · m(2.1~2.5 kg · m)

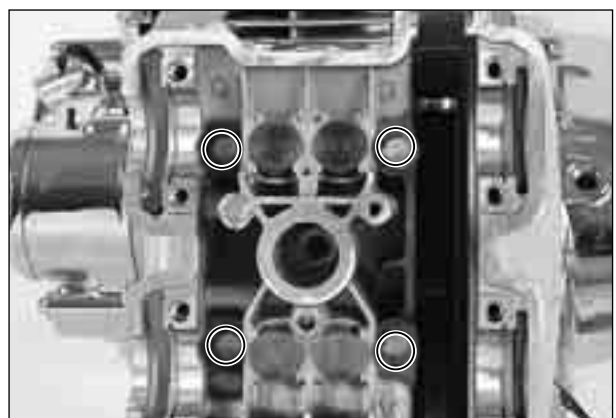
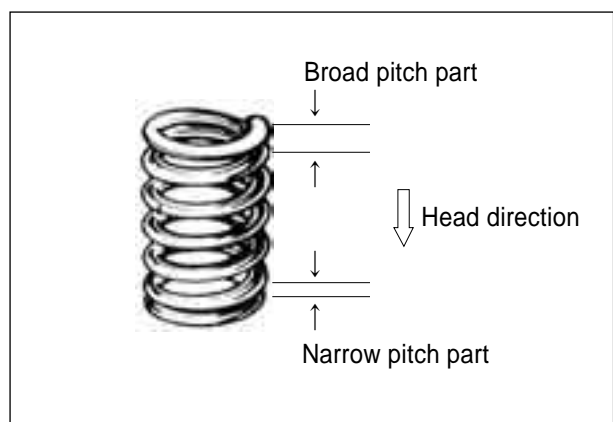
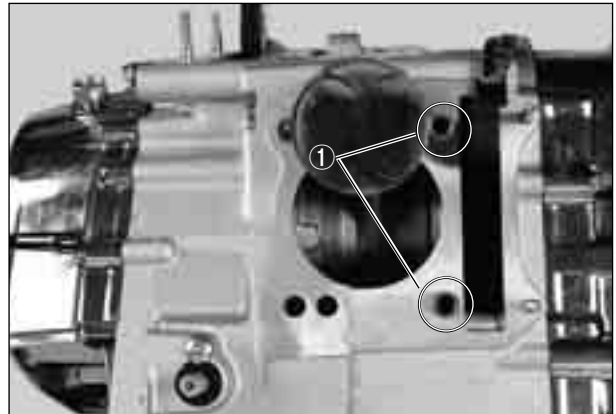

3-51 ENGINE

- Tighten the cylinder head base nuts.

 **Cylinder head base nut**
: 7~11 N · m(0.7~1.1 kg · m)

- Tighten the two cylinder head base cover nuts.

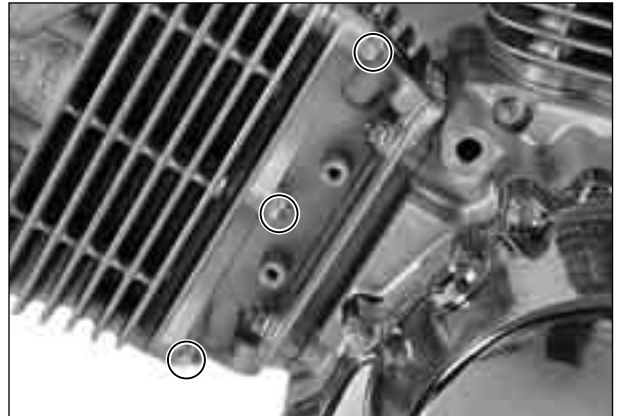
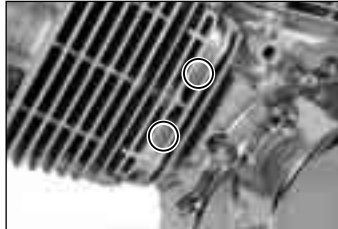

- Install the tappet and shim.

 **CAUTION**

With fit the tappet, it should be replaced if turn not smoothly by the hand.

 **CAUTION**

The tappet and shim should be installed at the original position when removed. If otherwise, it is difficult to adjust the valve clearance.

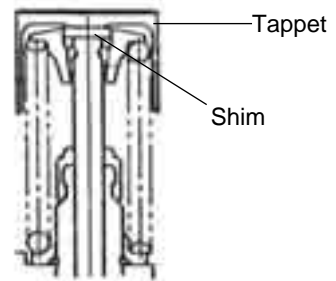

- Fit the chain guide.



[Rear Cylinder]



[Front Cylinder]

- Fit the C-ring.



⦿ CAMSHAFT ASSEMBLY

- Distinguish the “EX” mark for the exhaust camshaft, the “IN” mark for the intake camshaft.
Be distinguished always each camshaft what has notch at the rightside end and leftside end of it.
- When installing the camshaft and cam sprocket, apply a small quantity THREAD LOCK “1324” to the bolts and tighten with the specified torque.

 **THREAD LOCK “1324”**

 **Camshaft sprocket bolt**
: 10~12 N · m(1.0~1.2 kg · m)

- Apply the engine oil to the camshaft bearings.

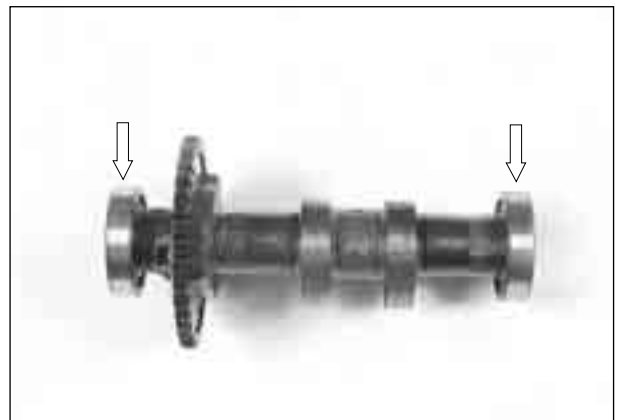
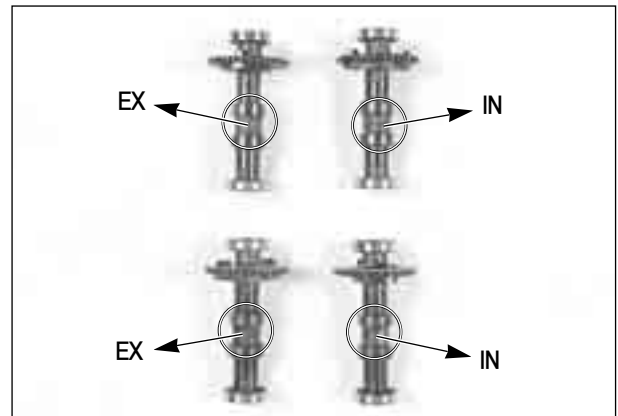

- With pull up the camshaft drive chain, align the “ | F” mark of magneto rotor into the punching mark of magneto cover to turn the crankshaft.(Front cylinder)

CAUTION

When adjusting the rear cylinder, align the “ | R” mark of magneto rotor into turn counter-clockwise 285° at the position of front cylinder.



CAUTION

If turn the crankshaft without pulling up the camshaft drive chain, the chain may be fallen off between the crankcase and cam chain drive sprocket.

- The front cylinder head install first the exhaust camshaft, following the intake camshaft.
The rear cylinder head install first the intake as the cam chain tension adjuster exist exhaust side.



3-53 ENGINE

- The notch mark “—” of exhaust camshaft should be aligned with the plane of cylinder head.
At that time, the “2” arrow of exhaust camshaft sprocket should be in a vertical position to the plane of cylinder head when exhaust camshaft sprocket was geared into camchain.
- The notch mark “—” of intake camshaft should be toward the outside and aligned with the plane of cylinder head. At that time, the “3” arrow of intake camshaft sprocket should be in a vertical position to the plane of cylinder head when the intake camshaft sprocket was geared into the camchain.
- Gear into the chain at the “3” arrow of intake sprocket that count the 16th of chain roller pin from the roller pin on the “2” arrow of exhaust sprocket to the intake camshaft.

CAUTION

The rear cylinder gear into that count the 16th of chain roller pin from the “3” arrow of intake sprocket to the “2” arrow of exhaust sprocket.

- Install the “3” arrow punching mark of intake camshaft sprocket with the surface of cylinder head vertically.
- The camshaft sprocket use the intake and exhaust (the front and rear is different) in common, but use to distinguish according as installation with the camshaft.

For example,

Front exhaust : Camshaft exhaust + Front sprocket
(Install the camshaft pin at the E marking hole.)

Rear intake : Camshaft intake + Rear sprocket
(Install the camshaft pin at the RI marking hole.)

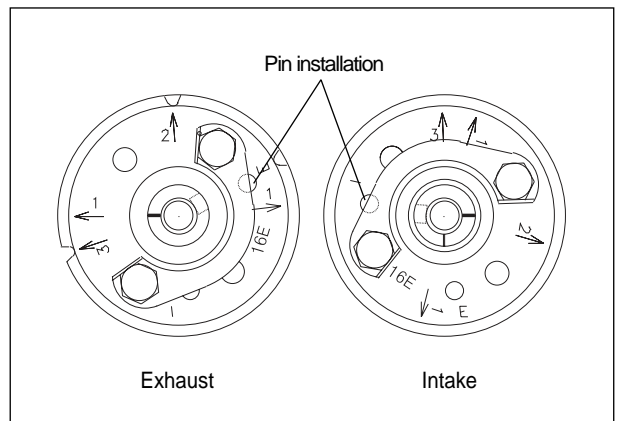
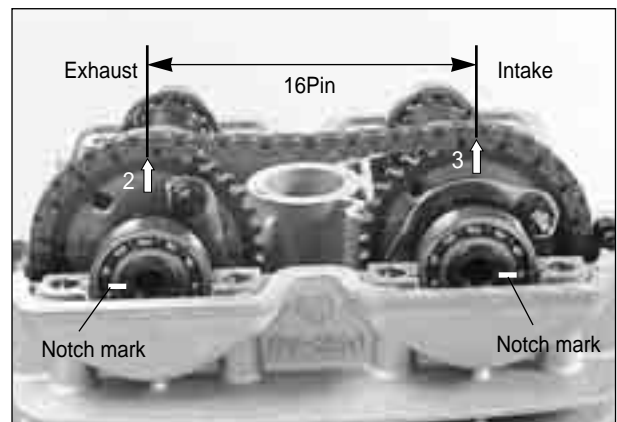
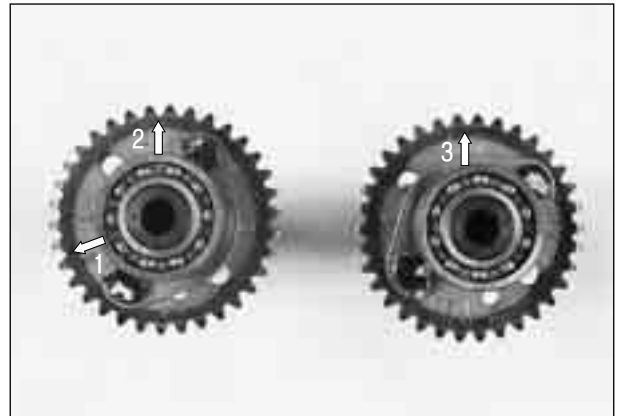

[Front Cylinder]

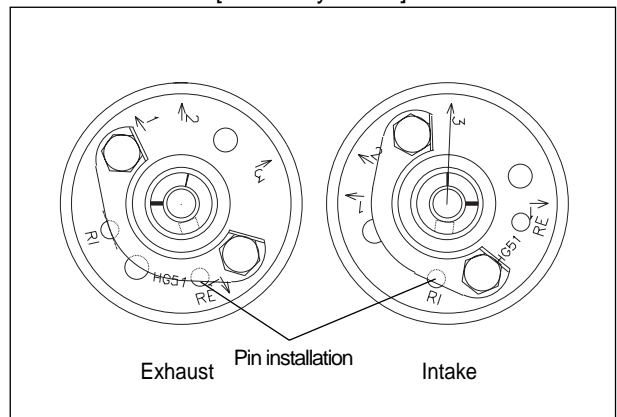

[Rear Cylinder]

CAUTION

The timing chain is installed to the all of three sprocket.
Be sure to lie the crankshaft until the four holder and cam chain tension adjuster are installed completely.

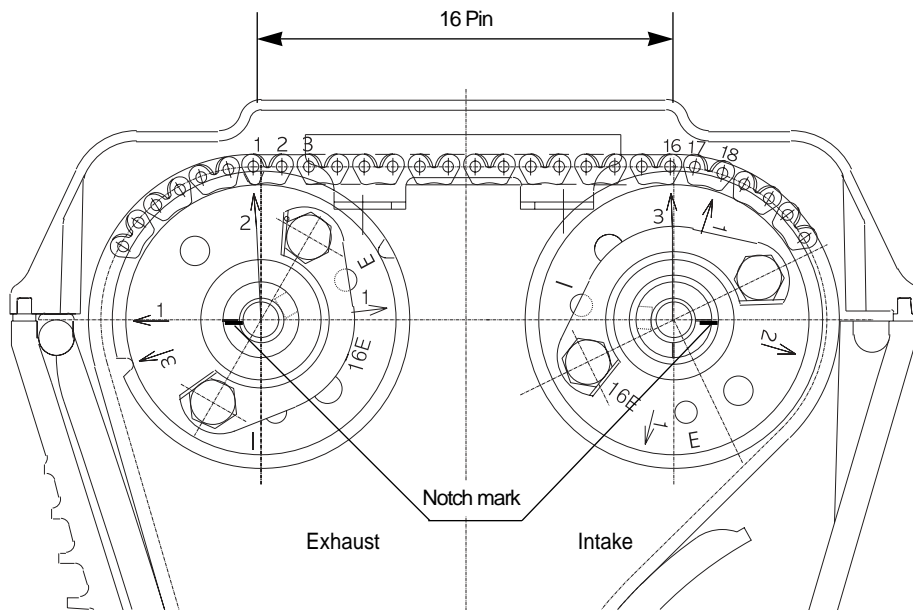
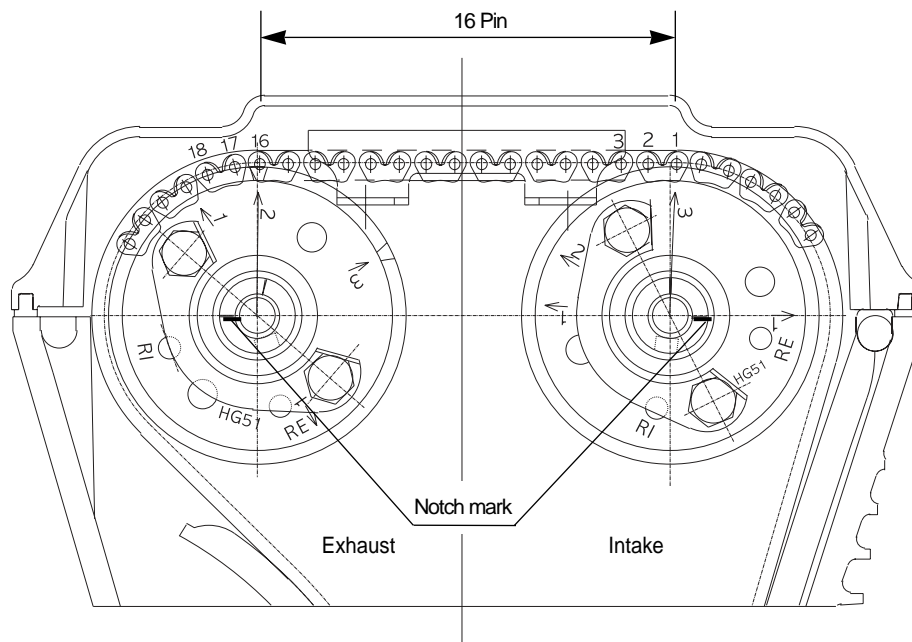
**[Front cylinder]****[Rear cylinder]****NOTE:**

The camshaft housing should be installed in the same manner with the front engine.

3-55 ENGINE

- Each camshaft housing is punched with “A” “B” “C” “D”.

Put on the housing “A” to the “A” of head surface, the housing “B” to the “B”, the housing “C” to the “C” and the housing “D” to the “D” as that “A” “B” “C” “D” is punched also to the cylinder head upper surface.

- Fix the four camshaft bearing holder by tightening of the bolt in order.
Install each bolt diagonally by using the wrench pulling the shaft down.
Tighten the bolt of each camshaft bearing holder with the same torque.

⚠ CAUTION

If get damaged the head or surface of camshaft bearing housing thrust, produce an result that the bearing housing not was tightened.

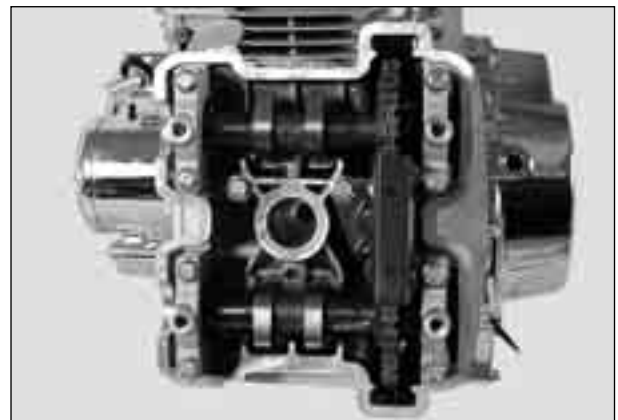
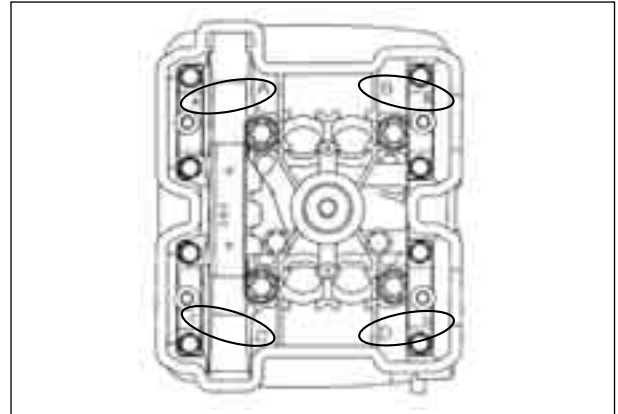

- Tighten the camshaft housing bolt with the specified torque.

⚠ CAUTION

The camshaft housing bolt is made of the special material.
This bolt is superior at the degree of hardness more than the different high tension bolt.
Pay special caution that the different type of bolt should not be used.
This bolt head is punched the “9” mark.

🔧 Camshaft housing bolt

: 8~12 N · m(0.8~1.2 kg · m)

- If turn the lock shaft handle in clockwise (↻) direction, the pushrod is inserted in.
Turn the mechanical spring continually until the handle is turned to the end.
- Fix the adjuster into the cylinder block.

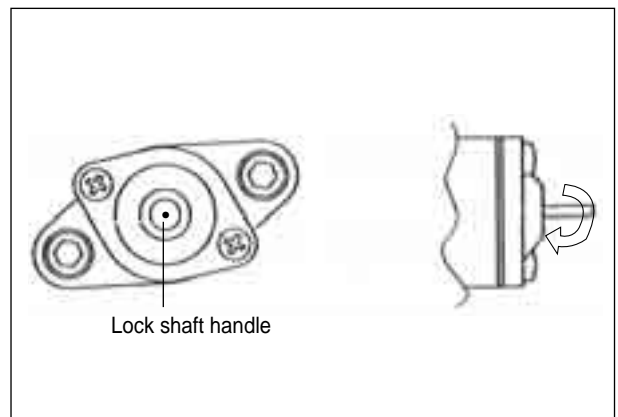

- Get out the pushrod for the front to turn the lock shaft handle in counter-clockwise (↺).

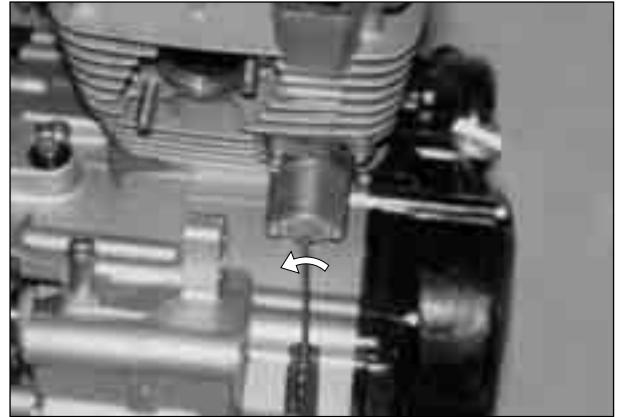

- Turn the crankshaft about 10 times counter-clockwise (↺) on the basis of the magneto rotor.
- If the valve clearance is within standard after measured the valve clearance, begin the next operation. If it is out of standard, adjust the valve clearance within standard limit after disassembled the camshaft and replaced the proper shim.

Valve clearance	Standard
IN.	0.1~0.2 mm
EX.	0.2~0.3 mm

- Adjust the valve clearance of rear cylinder with the same manner of the front cylinder. (Refer to page 2-5)

CAUTION

If you don't turn the crankshaft about 10 times before measured the valve clearance, there is no meaning in valve clearance.

- Apply BOND "1215" to the surface of cylinder head cover packing block.

 BOND "1215"

- Tighten the cylinder head cover bolts with the specified torque.

 **Cylinder head cover bolt**
: 12~16 N · m (1.2~1.6 kg · m)

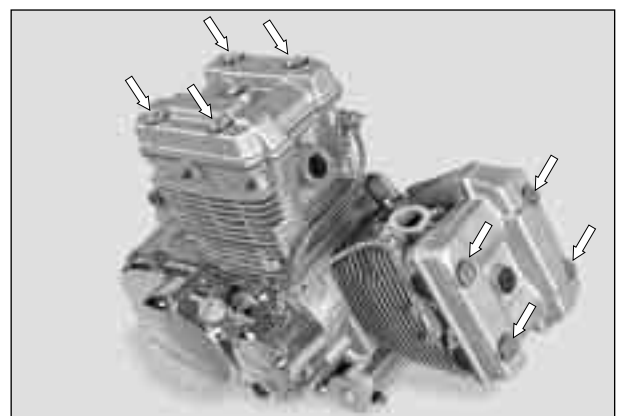
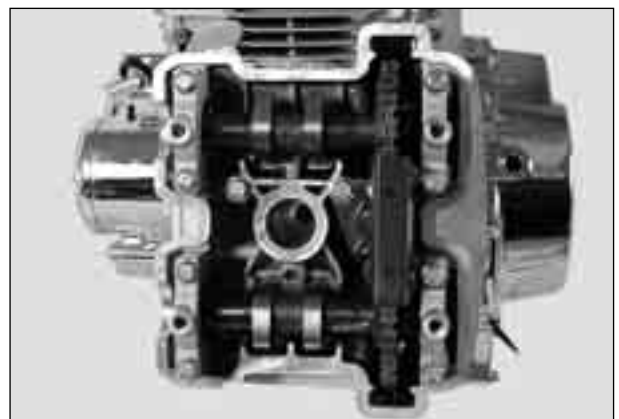

3-57 ENGINE

⊙ SPARK PLUG

- Install the spark plug.(Refer to page 2-5)

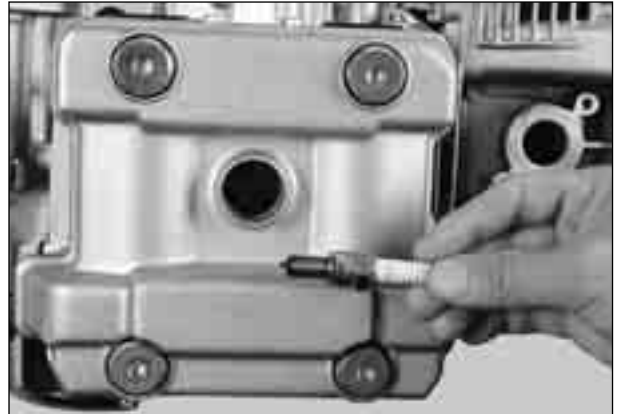

- Install the rear cylinder head and cylinder with the same manner which installed the front cylinder head and cylinder.

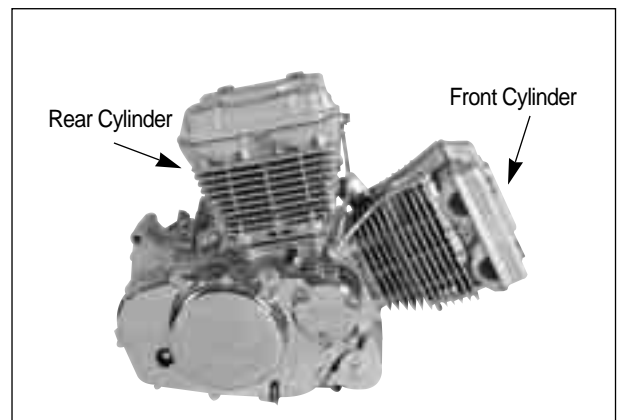

⊙ GEAR POSITION SWITCH

- Install the spring ① and contact ②.
- Apply SUPER GREASE "A" to the O-ring and install the gear position switch.

 SUPER GREASE "A"

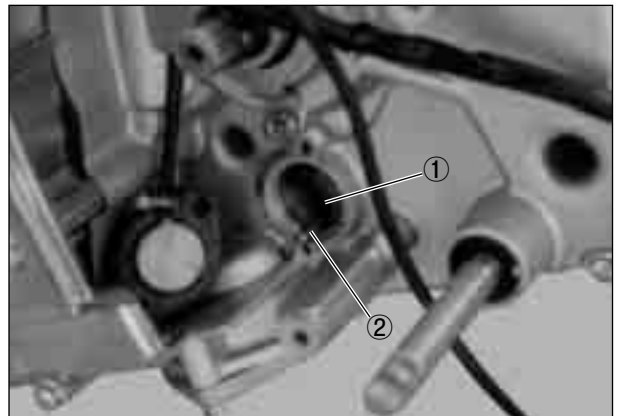

FUEL SYSTEM

CONTENTS

FUEL TANK / FUEL COCK	4- 1
FUEL PUMP	4- 2
CARBURETOR	4- 3

⚠ CAUTION

Gasoline must be handled carefully in an area well ventilated and away from fire or sparks.

FUEL TANK / FUEL COCK

⊙ REMOVAL

⚠ WARNING

Gasoline is very explosive. Extreme care must be taken.

- Remove the front seat. (Refer to page 6-1)
- Remove the fuel tank mounting nut and bolt, and take off the hooks.

- Turn the fuel cock to “OFF” and disconnect the fuel hose ①.
- Remove the fuel tank.

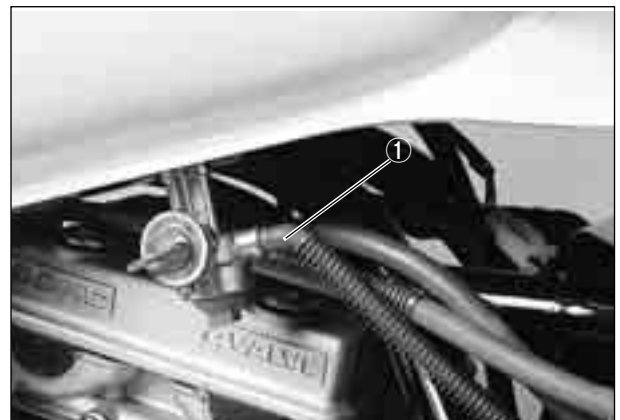
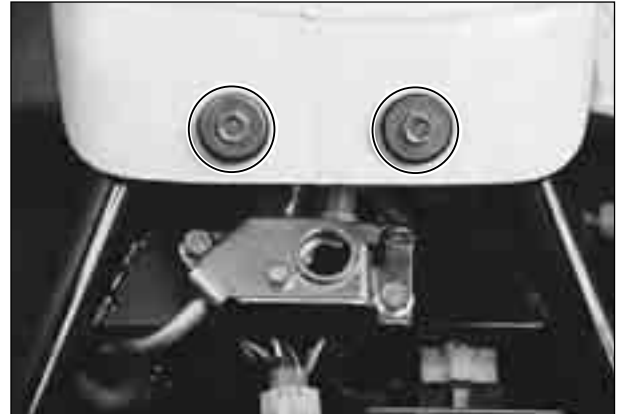

- Remove the fuel cock.



⊙ INSPECTION

■ FUEL COCK

If the fuel filter is dirty with sediment or rust, fuel will not flow smoothly and loss in engine power may result. Clean the fuel filter with compressed air. Also check the fuel cock for cracks.

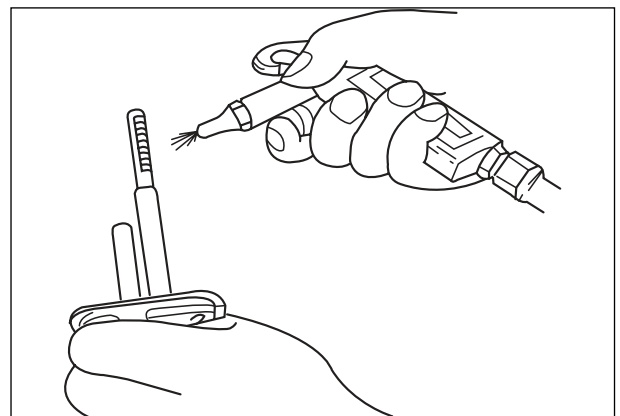

⊙ REMOUNTING

Remount the fuel tank and fuel cock in the reverse order of removal.

⚠ WARNING

- ❖ Gaskets ① and ② must be replaced with new ones to prevent fuel leakage.
- ❖ Tighten the fuel cock bolts evenly.

FUEL PUMP

⊙ REMOVAL

- Remove the left frame cover. (Refer to page 6-3)
- Turn the fuel cock to "OFF".
- Disconnect the fuel hoses ③, ④.
- Remove the fuel pump mounting bolts.
- Remove the fuel pump lead wire coupler ⑤.

⊙ INSPECTION

⚠ WARNING

Gasolin is very explosive. Extreme care must be taken.

- Disconnect the fuel hose ③, connect the suitable hose and insert the free end of the hose into a receptacle.

Check the fuel flow when starting the engine for few seconds by pressing the starter switch.

If the fuel flow is not found, check the fuel cock. (Refer to page 4-1)

If the fuel cock and hoses are not fault, check the fuel pump. (Refer to page 5-21)

⊙ REASSEMBLY

Carry out the assembly procedure in the reverse order of disassembly.

- Connect the fuel pump lead wire coupler ⑤.
- Tighten the fuel pump mounting bolts.
- Connect the fuel hoses ③, ④ securely.

FUEL HOSE ROUTING :

Fuel hose ③ (To fuel cock)

Fuel hose ④ (To carburetor)

⊙ FUEL PUMP RELAY

- Remove the fuel pump relay mounting bolts and coupler.
- Disconnect the fuel hose ④, and check the fuel flow when starting the engine for few seconds by pressing the starter switch.
- If the fuel pump are not fault, check the fuel pump relay. (Refer to page 5-21)

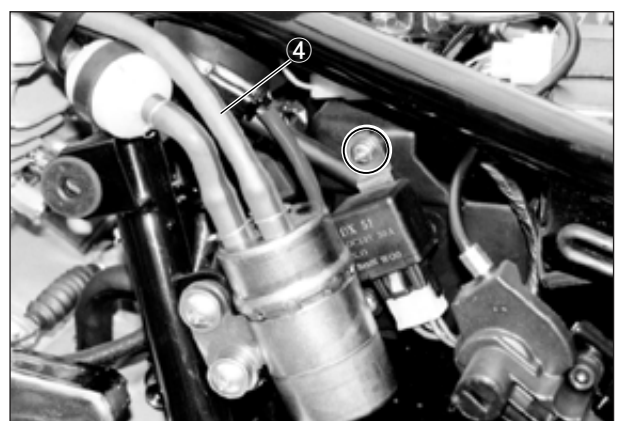
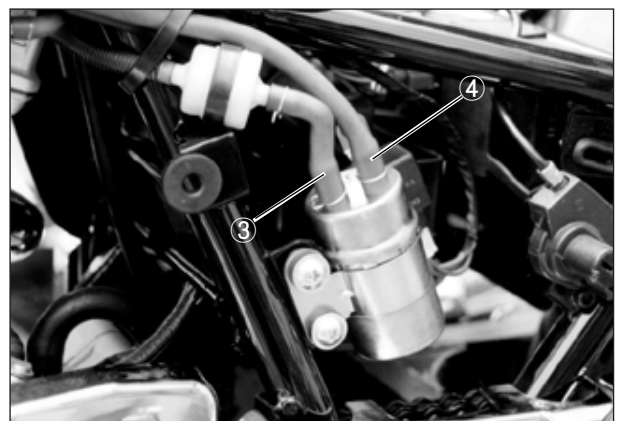
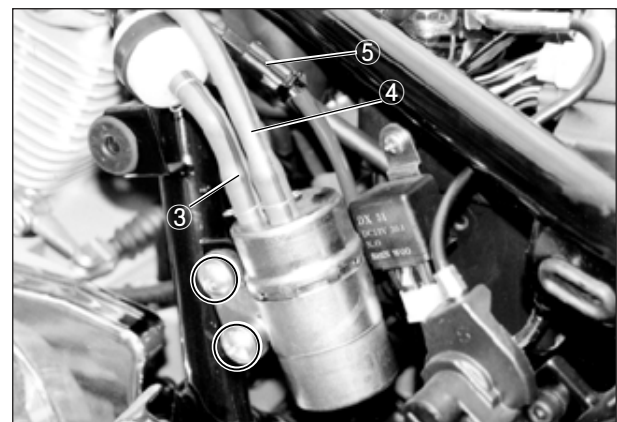

CARBURETOR

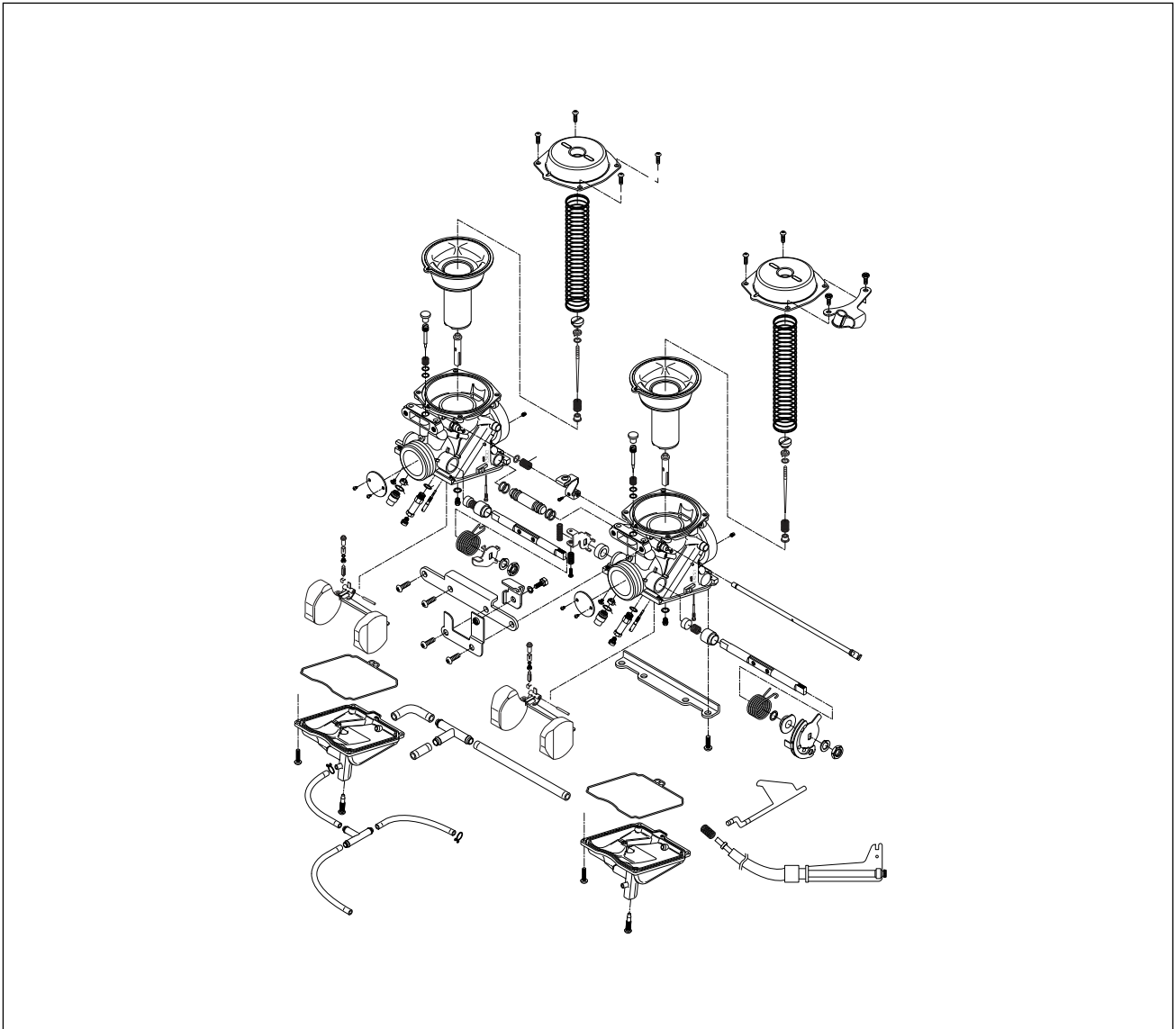

ITEM	SPECIFICATION		ITEM	SPECIFICATION	
Carburetor type	MIKUNI BDS 26 TYPE (DOUBLE)		Needle jet (N.J.)	O-6	O-6
Bore size	φ 26		Pilot jet (P.J)	20	20
I.D. NO.	HJ82		Throttle valve (TH.V.)	130	130
Idle rpm	1,450 ~ 1,550 rpm		By pass (B.P.)	# 1:0.9, # 2:0.9, # 3:0.8, # 4:0.8	# 1:0.9, # 2:0.9, # 3:0.8, # 4:0.8
Float height	17		Valve seat (V.S.)	1.2	1.2
Throttle cable play	0.5~1.0		Starter jet (G.S)	22.5	22.5
	FRONT	REAR	Pilot outlet (P.O.)	0.75	0.75
Main jet (M.J.)	90	87.5	PV STROKE (P.V.)	STD	STD
Main air jet (M.A.J.)	140	140			
Jet needle (J.N.)	2ND	2ND			

⊙ **LOCATION OF CARBURETOR I.D. NO.**

The carburetor I.D. is stamped on the location ① on the carburetor as shown in the right photo.

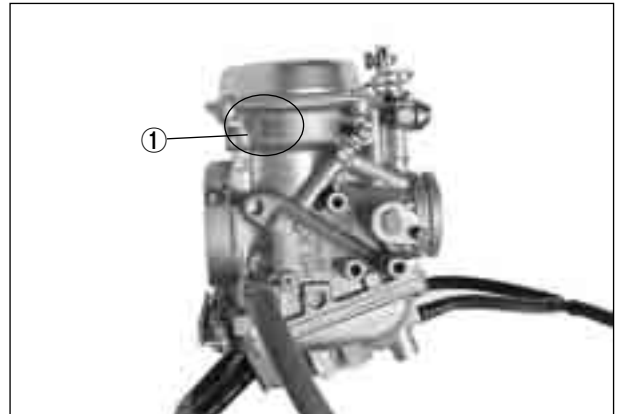

⊙ **REMOVAL**

- Remove the fuel tank. (Refer to page 4-1)
- Remove the fuel hose.



- Remove the throttle cables ② and choke cable ③.
- Loosen the clamp screw and remove the carburetor.



⊙ **DISASSEMBLY**

- Remove the diaphragm cover ④.

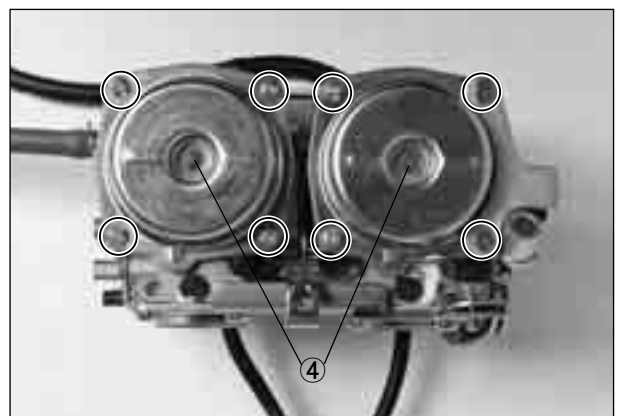

4-5 FUEL SYSTEM

- Remove the spring ① and piston valve ② along with diaphragm ③.

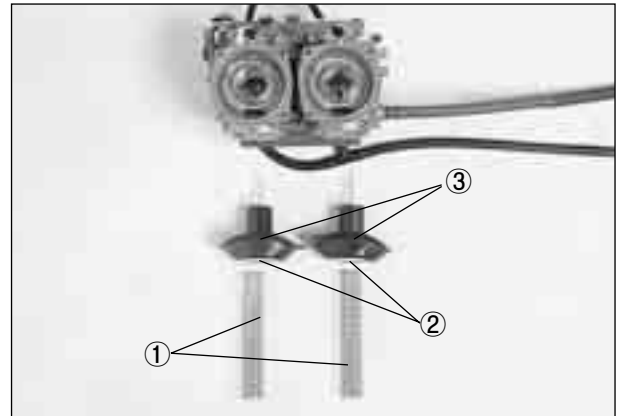

- Remove the jet needle cap ④, spring ⑤, retainer ⑥, and jet needle ⑦.

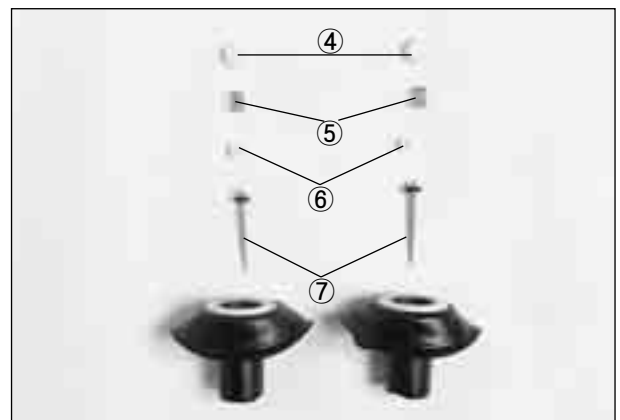

- Remove the float chamber body ⑧.

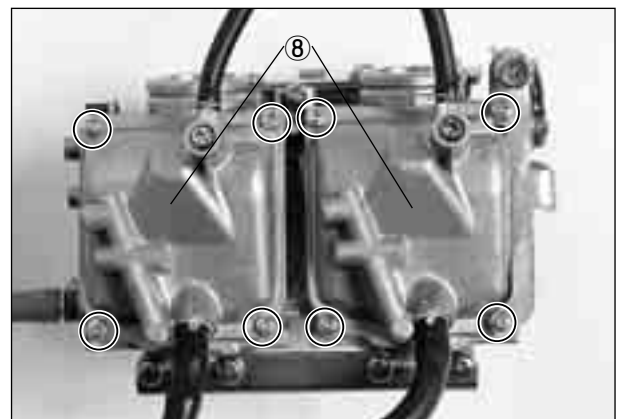

- Remove the float assembly ⑩ along with the needle valve ⑨ by removing the pin.

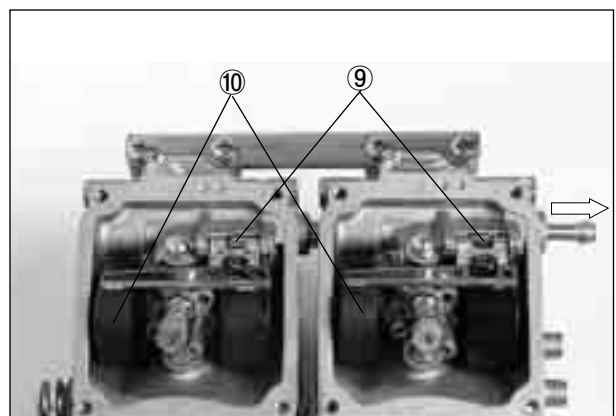

- Remove the valve seat ①.
- Remove the main jet ②, jet holder ③ and pilot jet ④.

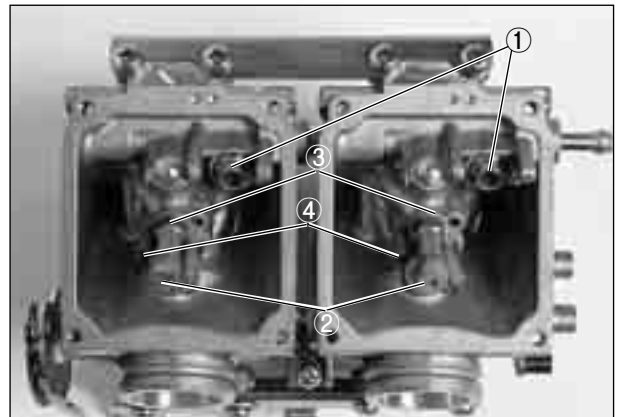

- Remove the throttle cable bracket ⑤.



- Remove the pilot screw ⑥ with count and tighten the number of turn.

NOTE:
Record the number of turn for the pilot screw when install to confer.

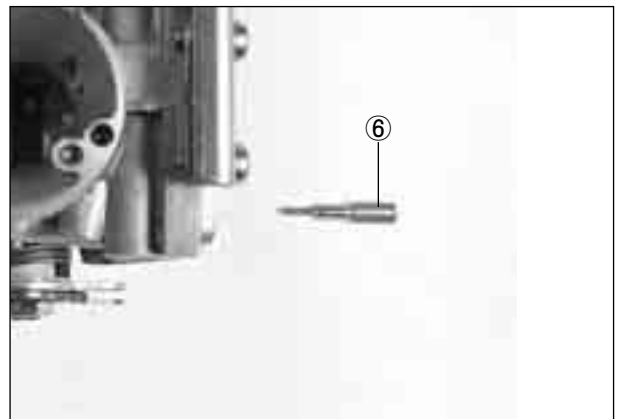

⊙ **INSPECTION**

Check the following parts for damage and clogging.

- | | |
|---------------------|---------------------------|
| • Pilot jet | • Piston valve |
| • Main jet | • Starter jet |
| • Main air jet | • Gaskets and O-rings |
| • Pilot air jet | • Pilot outlet and bypass |
| • Needle jet holder | • Float |
| • Needle valve | • Jet needle |
| • Valve seat | |

If any abnormal condition is found, wash the part clean.
 If damage or clogging is found, replace the part with a new one.

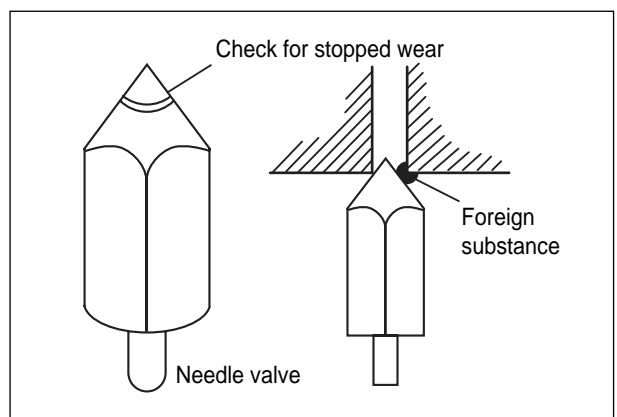

4-7 FUEL SYSTEM

⊙ CLEANING

- Clean all jets by using compressed air.
- After cleaning, reassemble the carburetor with new seals and gaskets.

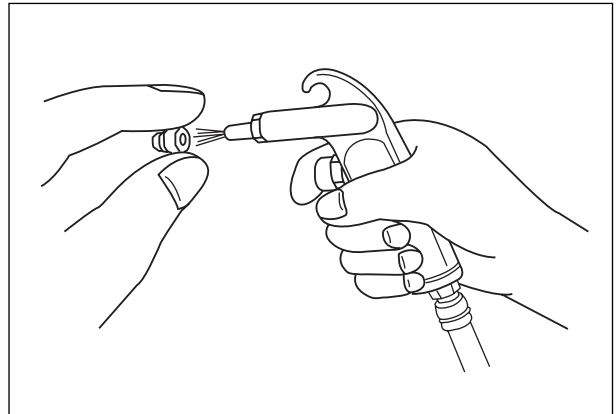

⊙ FLOAT HEIGHT ADJUSTMENT

To check the float height, turn the carburetor upside down. Measure the float height **A** while the float arm is just contacting the needle valve using vernier calipers.

Float height **A**

17mm

 Vernier calipers : 09900-20101

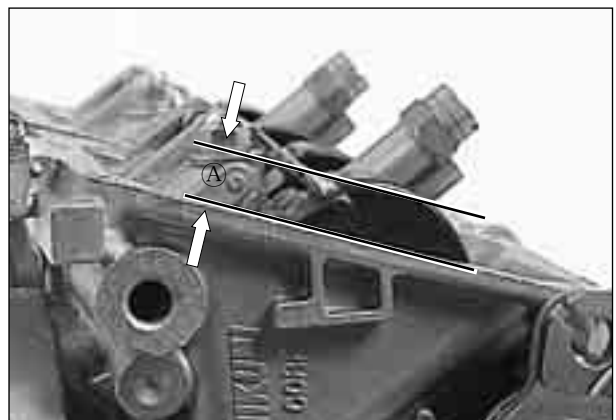

- Bend the float arm **1** as necessary to bring the height **A** to the specified level.
- After adjustment, check the float height and the fuel level again.

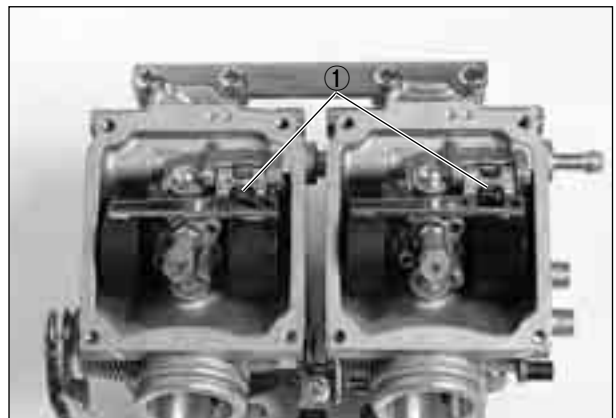

⊙ REASSEMBLY

Carburetor reassembly can be performed in the reverse order of disassembly. When reassembling, carefully observe the following instructions.

- After cleaning, reinstall the pilot screw to the original number of turn that is recorded during disassembly.

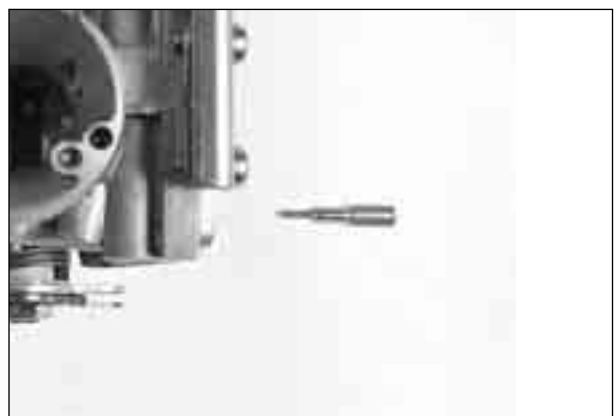

- Fit the seal rings securely to the float chamber and install the float chamber to the throttle body.
- Install the eight screw ①.

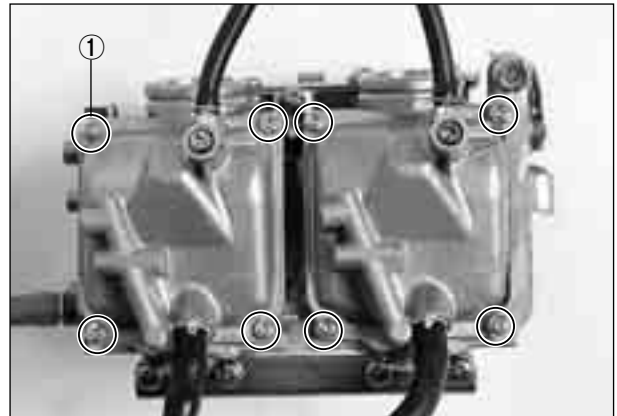

- Install the jet needle with the pin ② on the spacer securely engaged with the hole ③ on the piston valve.

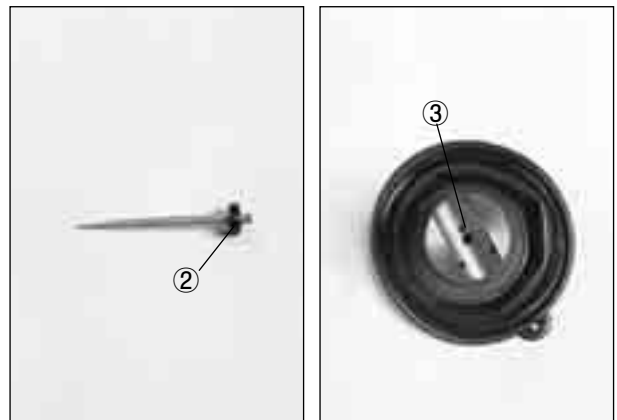

- Align the hole ④ of the diaphragm with passage way on the carburetor body.

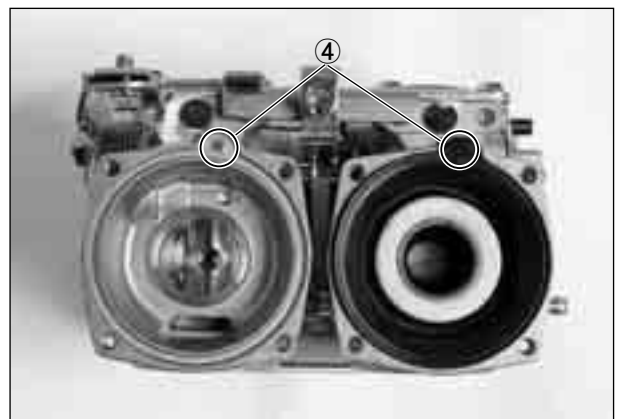

- Install the eight screw ⑤.



4-9 FUEL SYSTEM

⚠ CAUTION

Never adjust “CO adjust screw” **A** of the carburetor. If adjust at discretion, have a bad influence upon output of the engine as the two carburetor is disharmonious.

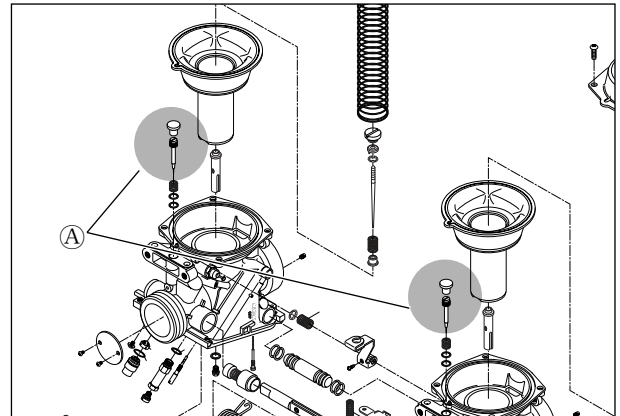

- After the assembly and installation on the engine have been completed, perform the following adjustment.

Throttle cable adjustment. (Refer to page 2-8)

Idle speed adjustment. (Refer to page 2-8)

ELECTRICAL SYSTEM

CONTENTS

LOCATION OF ELECTRICAL COMPONENTS	5- 1
IGNITION SYSTEM	5- 3
CHARGING SYSTEM	5- 7
STARTER SYSTEM AND SIDE STAND	5- 11
IGNITION INTERLOCK SYSTEM	
SWITCHES	5- 15
LAMP	5- 16
BATTERY	5- 18
FUEL SYSTEM	5- 21

LOCATION OF ELECTRICAL COMPONENTS

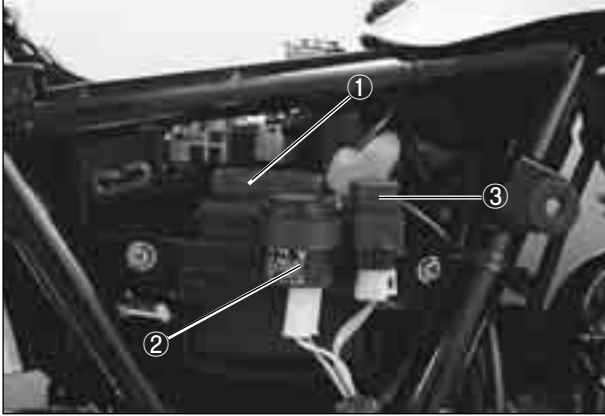

- ① Battery
- ② Turn signal relay
- ③ Fuse

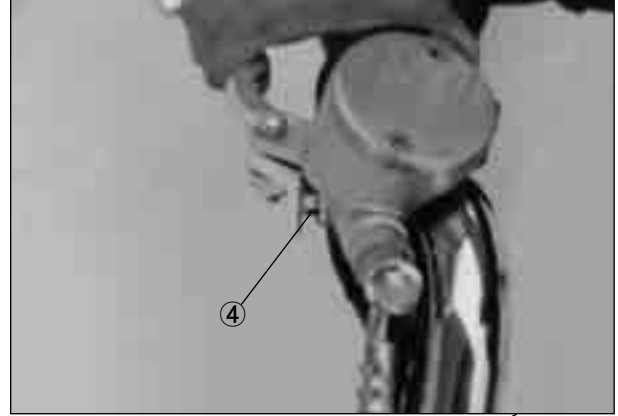

- ④ Front brake lamp switch

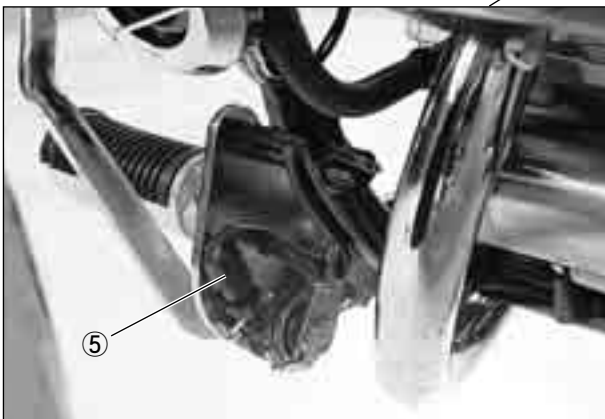
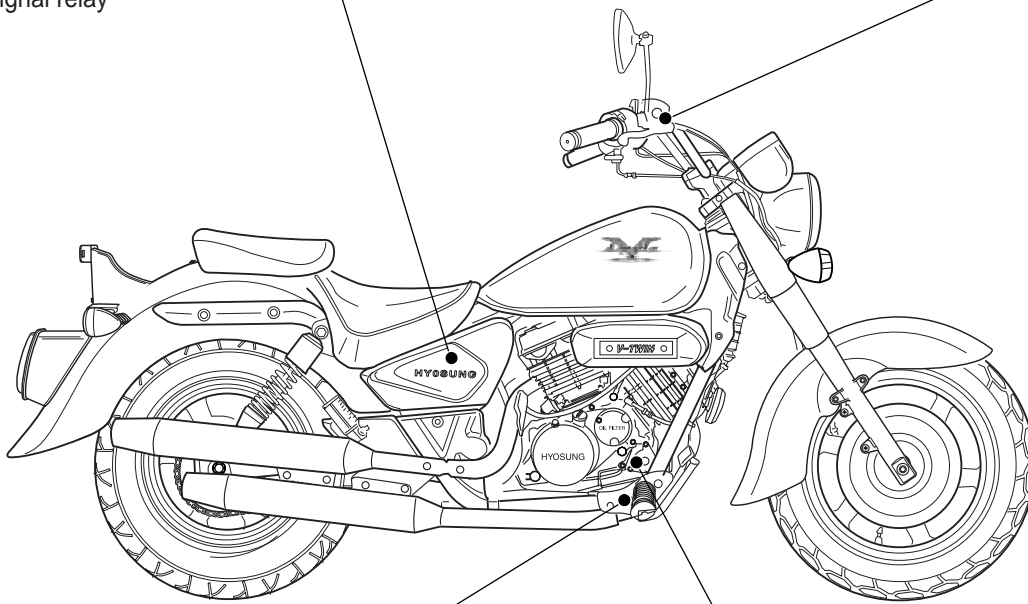

- ⑤ Rear brake lamp switch

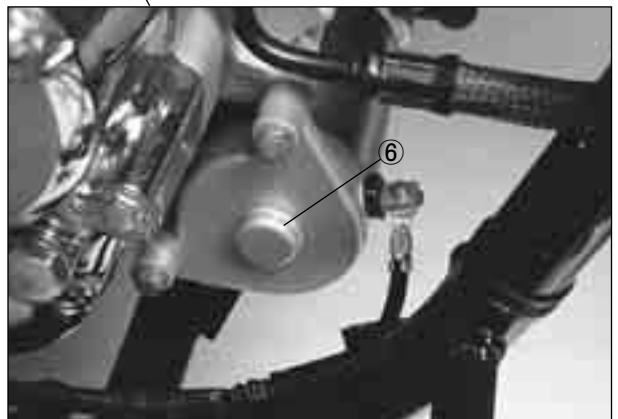

- ⑥ Starter motor

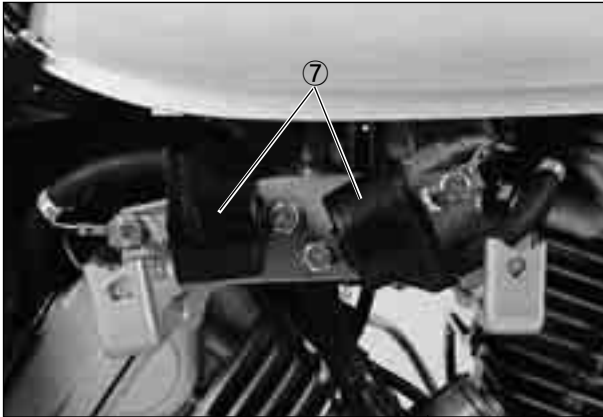

⑦ Ignition coil (NO.1 & NO.2)

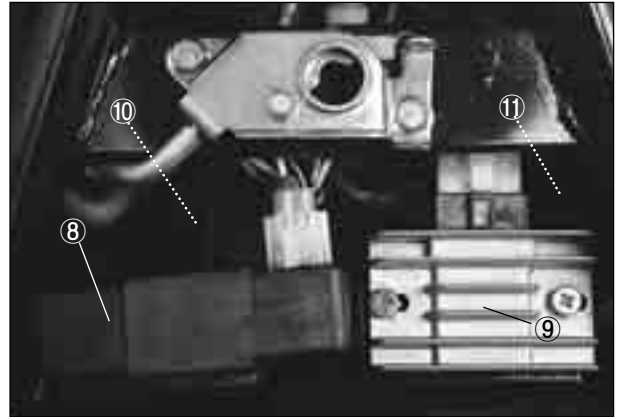

⑧ C.D.I Unit
 ⑨ Regulator / Rectifier
 ⑩ Battery plus terminal
 ⑪ Battery minus terminal

CAUTION

Be sure not to misassemble the position of battery plus & minus terminal.

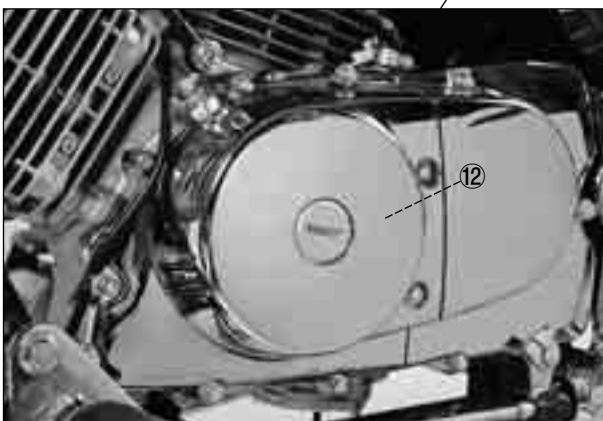
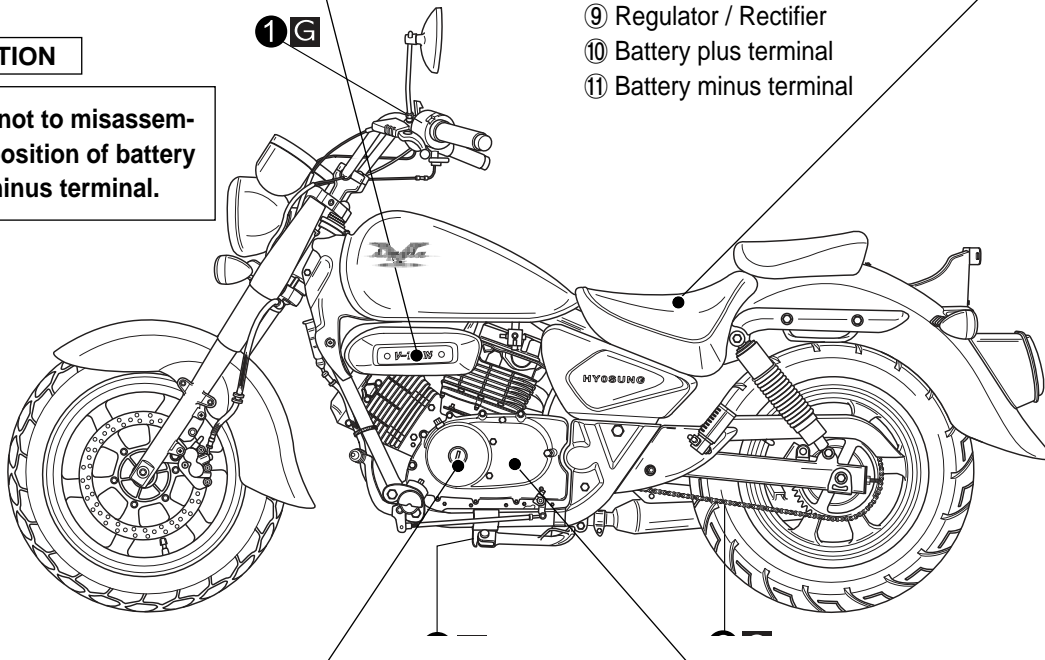

⑫ Magneto

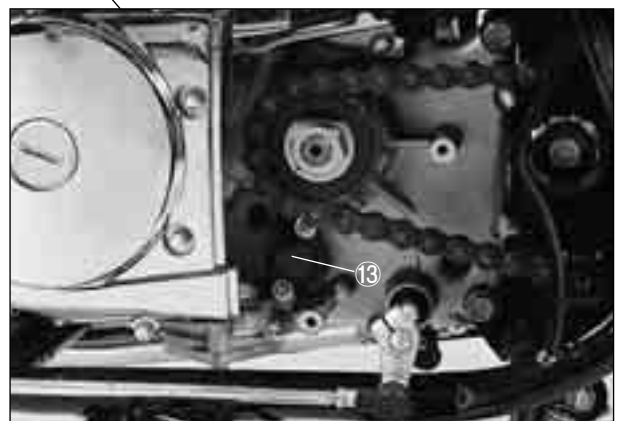

⑬ Gear position switch

IGNITION SYSTEM

Aquila 250 is started as the battery discharged ignition system without a contact point. The battery ignition system is composed a rotor with five rotor tip, the D.C CDI, the ignition coil and battery. Ignite after permit signal at ignition timing of pick-up as electric energy of this battery, occur the 1st electric current. Therefore a high voltage current is induced in the secondary winding of the ignition coil resulting in strong spark between the spark plug gap.

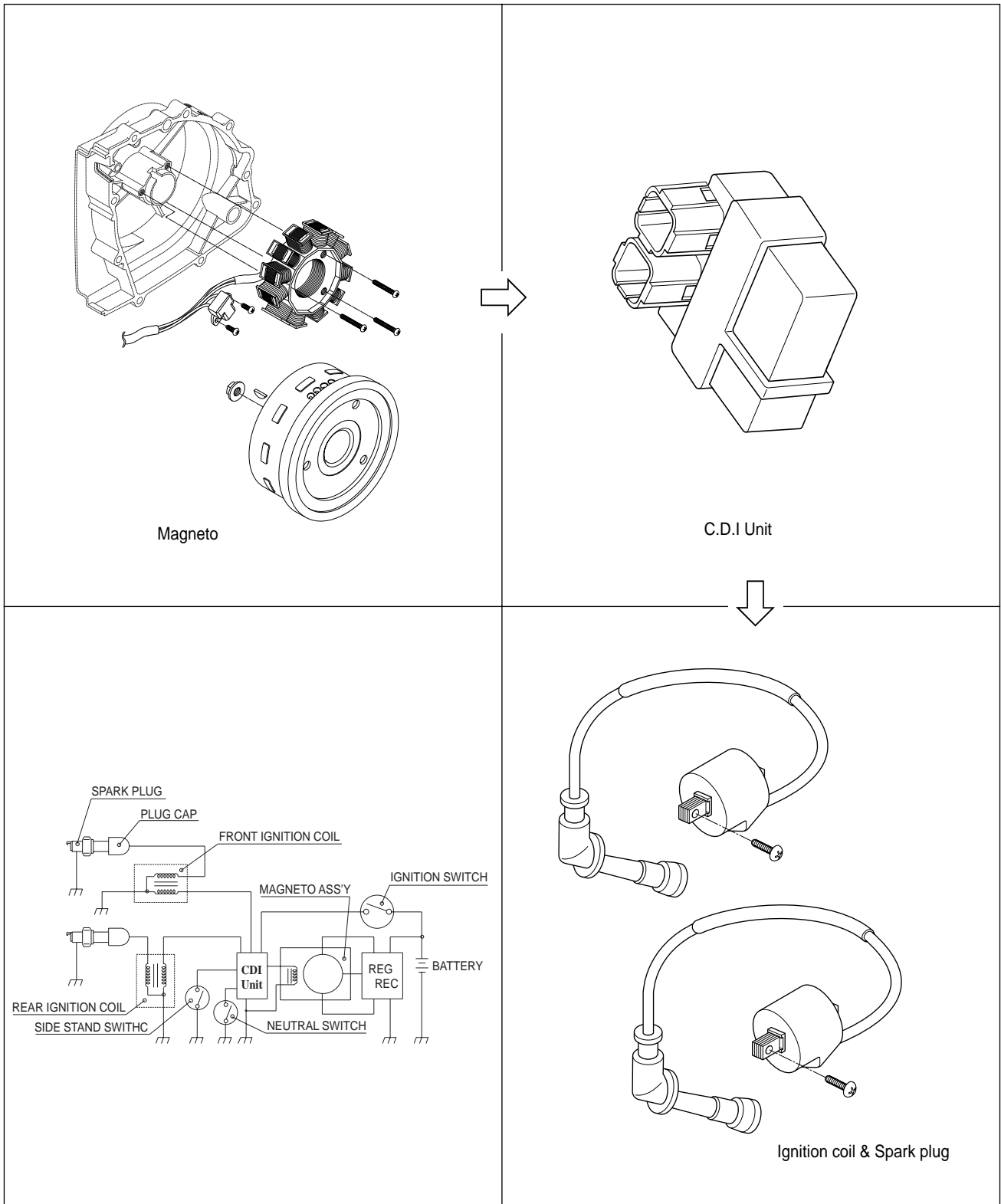

⊕ **INSPECTION**

■ **MAGNETO**

Using the pocket tester, measure the resistance between the lead wires in the following table.

Pick-up coil	G - L Approx 90~110 Ω
Charging coil	Y - Y Approx 0.6~0.9 Ω

 **Pocket Tester : 09900-25002**

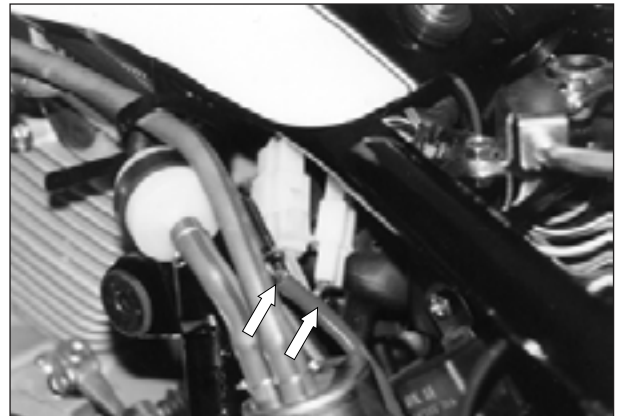

 **CAUTION**

When mounting the stator on the magneto cover, apply a small quantity of **THREAD LOCK "1324"** to the threaded parts of screws.

 **THREAD LOCK "1324"**

WIRE COLOR

- L : Blue
- G : Green
- Br : Brown
- B / Y : Black with Yellow tracer
- O / B : Orange with Black tracer
- G / W : Green with White tracer
- B / W : Black with White tracer
- W / L : White with Blue tracer

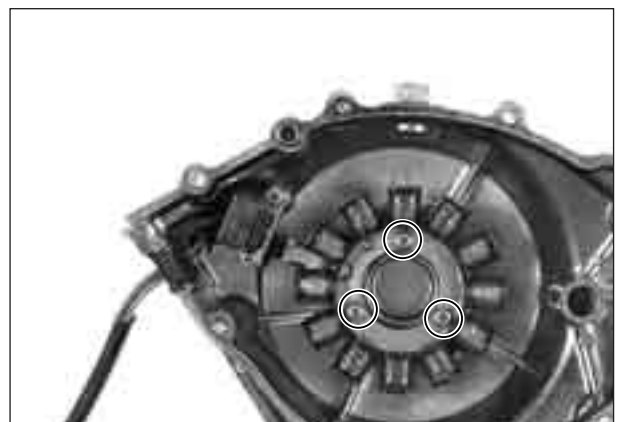

■ **CDI UNIT**

Using the pocket (R × 1kΩ range), measure the resistance between the lead wires in the following table.

Unit : kΩ

		⊕ Probe of tester							
		1	2	3	4	5	6	7	8
⊖ Probe of tester	1	—	∞	∞	30~200	30~200	30~200	30~200	10~100
	2	5~100	—	∞	5~50	2~50	5~50	5~50	1~20
	3	10~100	∞	—	5~50	2~50	5~50	5~50	1~20
	4	∞	∞	∞	—	∞	∞	∞	∞
	5	30~150	∞	∞	30~150	—	1~30	30~150	5~50
	6	10~100	∞	∞	10~100	5~50	—	10~100	2~20
	7	∞	∞	∞	∞	∞	∞	—	∞
	8	10~50	∞	∞	5~30	2~30	2~50	2~50	—

 **Pocket Tester : 09900-25002**

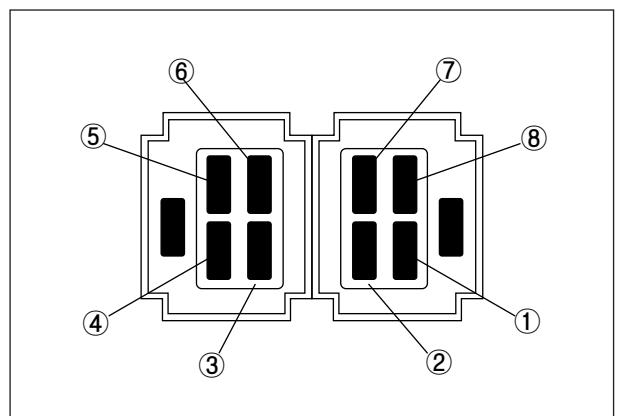
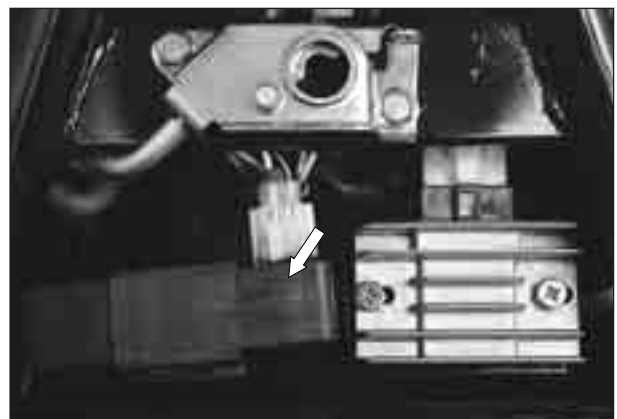

5-5 ELECTRICAL SYSTEM

⚠ CAUTION

- ❖ Pay caution as the numerical value differs a little according to the tester.
- ❖ Please remind that there may be defect which can not be identified even though the measurement by using the tester indicates a low voltage.
- ❖ The range of measurement adjust a [x 1kΩ] unit.

⊙ INSPECTION

■ IGNITION COIL (Checking with Electro Tester)

- Remove the ignition coil ①, ②.
- Make sure that the three-needle sparking distance of the electro tester is set at 8 mm (0.3 in).
- With the electro tester, test the ignition coil for sparking performance.
- If no sparking or orange color sparking occurs in the above conditions, it may be caused by the defective coil.

Spark performance Over 8 mm (0.3 in)

 Electro tester : 09900-28107

⚠ WARNING

Do not touch the wire clips to prevent an electric shock when testing.

⚠ CAUTION

When using the electro tester, follow the instruction manual.

⚠ CAUTION

The ignition coil is marked the **F** for front, and the **R** for rear.
If otherwise, it may occur severe damage to the engine.

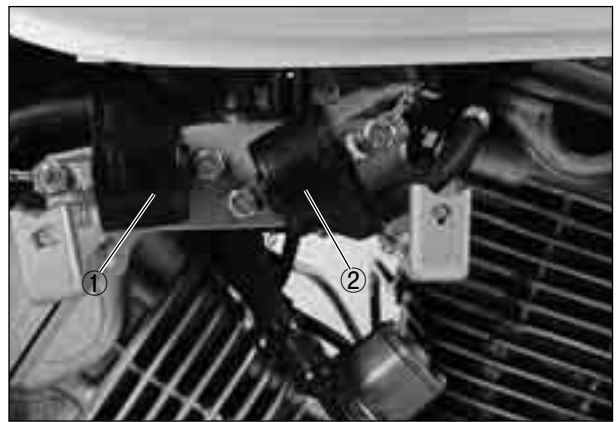

① Front cylinder ignition coil ② Rear cylinder ignition coil

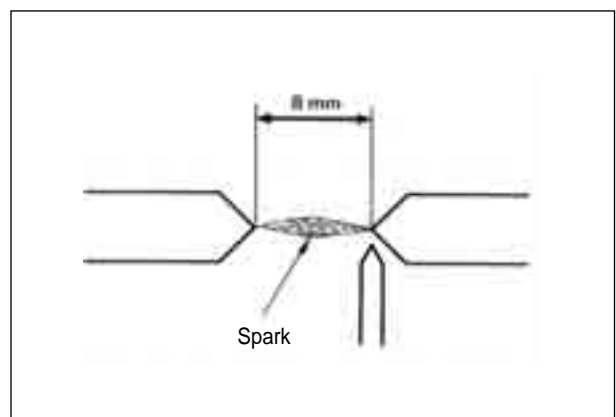
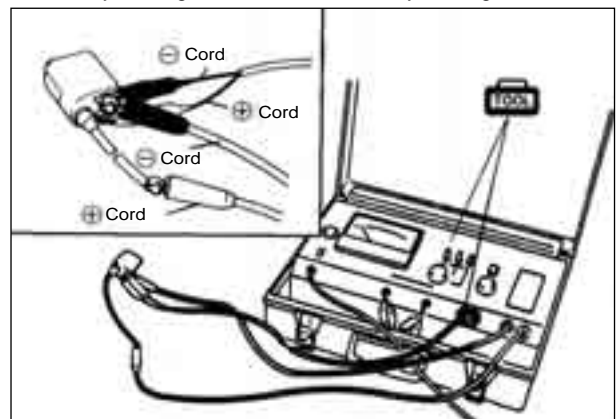

■ IGNITION COIL (Checking with Pocket Tester)

- A pocket tester or an ohm meter may be used, instead of the electro tester. In either case, the ignition coil is to be checked for continuity in both primary and secondary windings. Exact ohmic readings are not necessary, but, if the windings are in sound condition, their continuity will be noted with approximate ohmic values.

Ignition coil resistance		
Primary	0.19~0.24 Ω	Tester knob indication \times 1 Ω range
Secondary	5.4~6.6 k Ω	Tester knob indication \times 1k Ω range
Check to attached plug cap		

 **TOOL** Pocket tester : 09900-25002

■ SPARK PLUG

Clean the plug with a wire brush and pin. Use the pin to remove carbon, taking care not to damage the porcelain.

- Check the gap with a thickness gauge.

Spark plug gap	0.7 ~ 0.8 mm
-----------------------	--------------

 **TOOL** Thickness gauge : 09900-20806

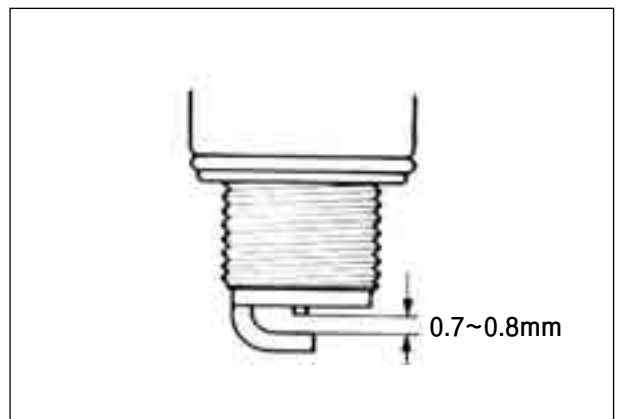
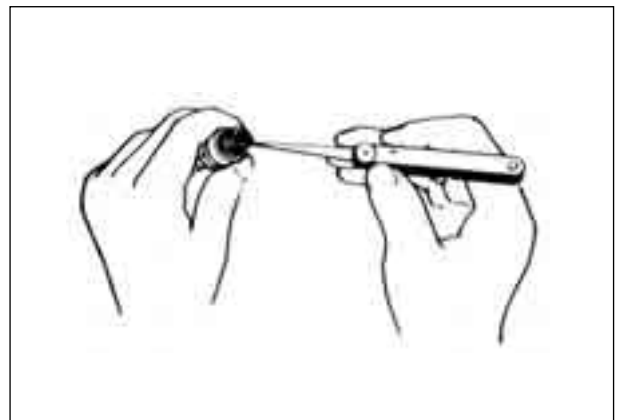
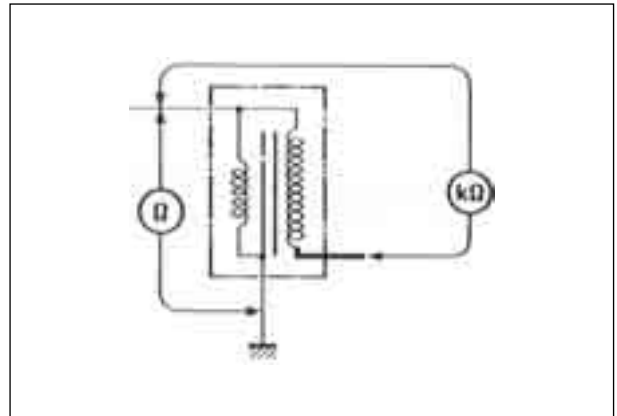

CHARGING SYSTEM

The circuit of the charging system is indicated in figure, which is composed of the AC generator, regulator / rectifier unit and battery. The AC current generated from the AC generator is converted by the rectifier and is turned into the DC current, then it charges the battery.

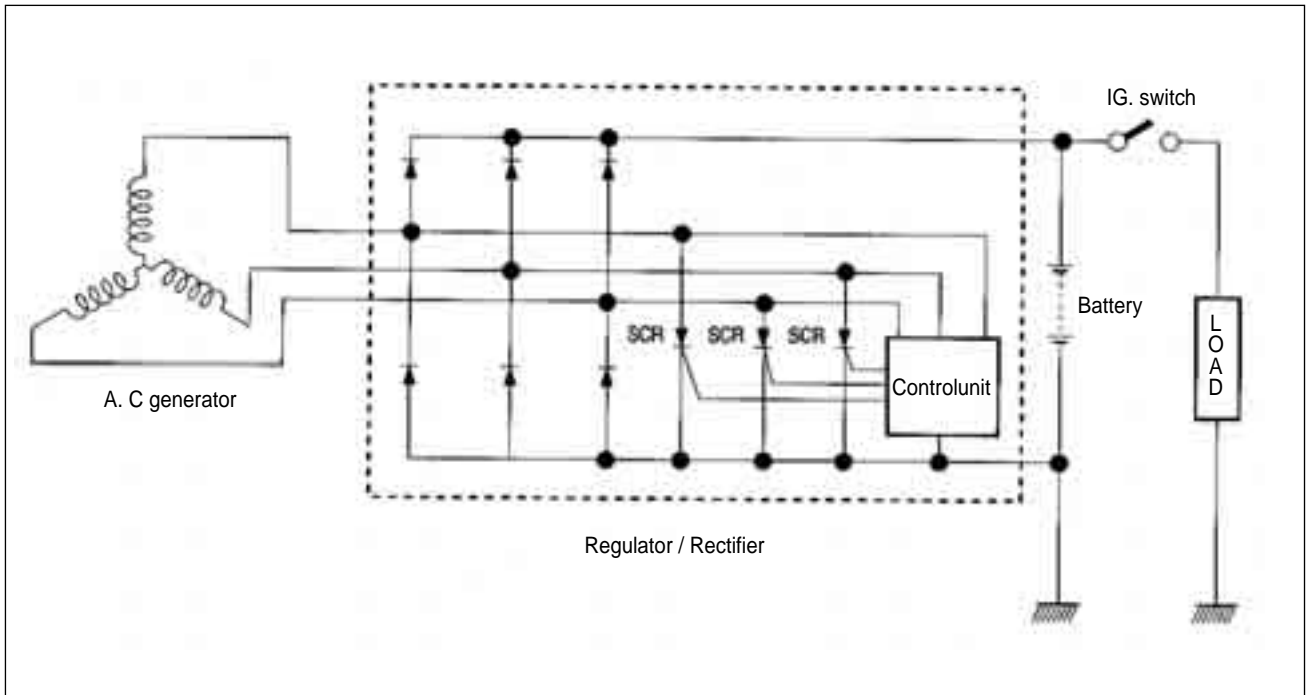

⊙ FUNCTION OF REGULATOR

While the engine rpm is low and the generated current of the AC generator is lower than the adjusted voltage of the regulator, the regulator does not function, incidentally the generated current charges the battery directly.

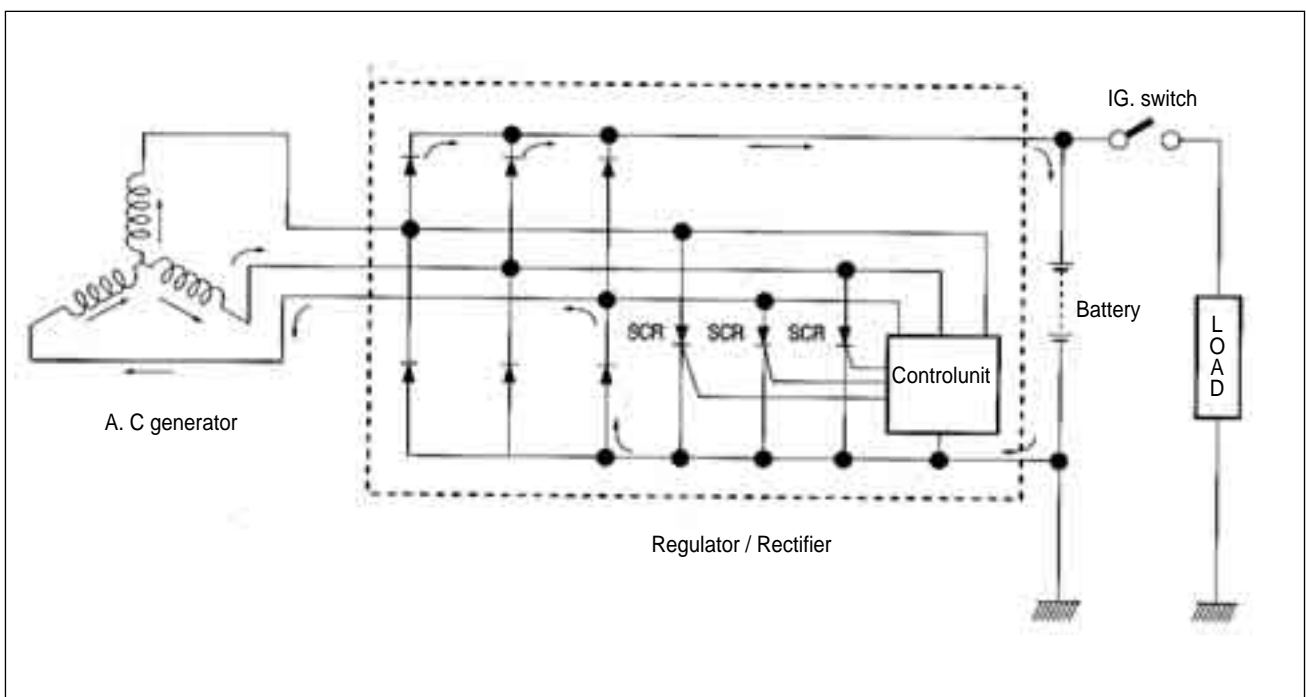

When the engine rpm become higher, the generated voltage of the AC generator also becomes higher and the voltage between points **A** and **B** of the regulator according becomes high, and when it reaches the adjusted voltage of the control unit, consequently the control unit becomes "ON" condition. On the "ON" condition of the control unit, signal will be sent to the SCR (Thyristor) gate probe and SCR will become "ON" condition. Then the SCR becomes conductive to the direction from point **A** to point **B**. Namely at the state of this, the current generated from the AC generator gets through SCR without charging the battery and returns to the AC generator again. At the end of this state, since the AC current generated from the AC generator flows into the point **B**, reverse current tends to flow to SCR, then the circuit of SCR turns to "OFF" mode and begins to charge the battery again. Thus these repetitions maintain charging constant voltage to the battery and protect it from overcharging.

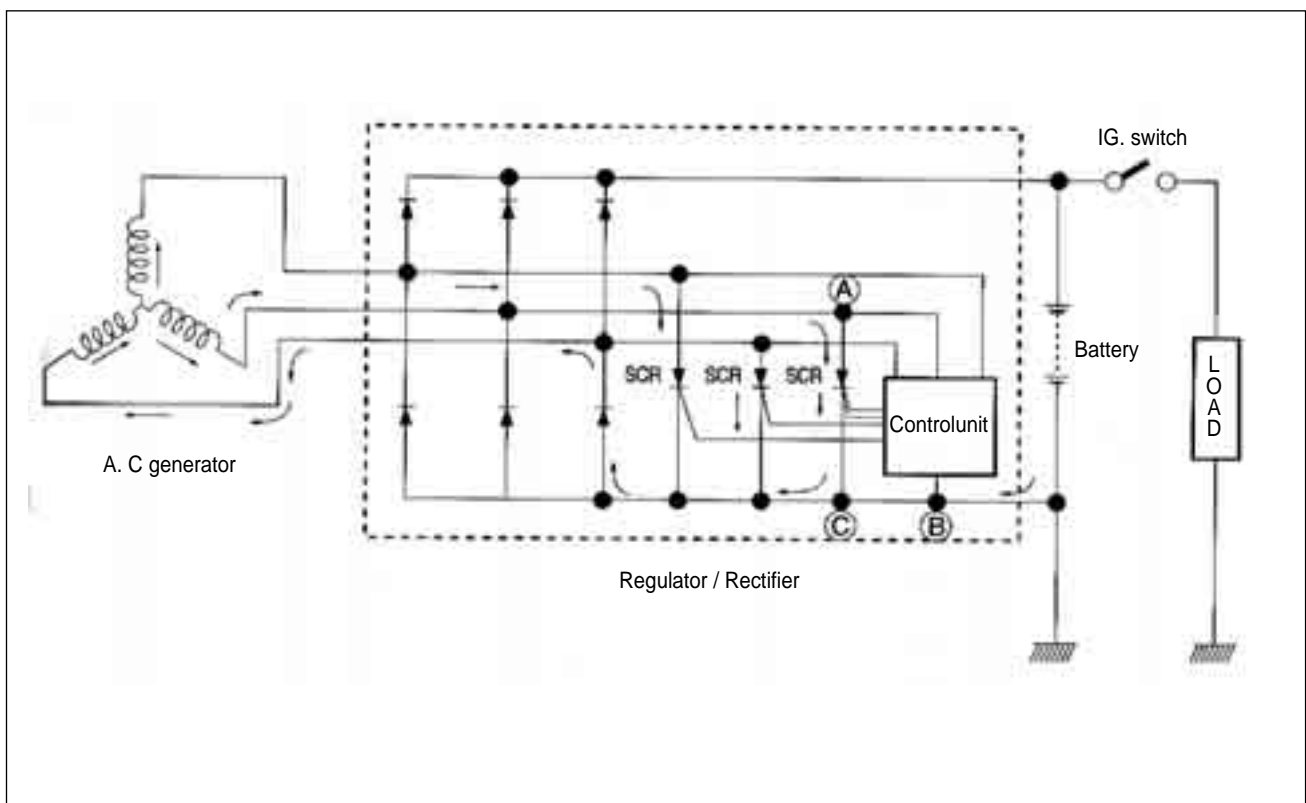

5-9 ELECTRICAL SYSTEM

⊙ INSPECTION

■ CHARGING OUTPUT CHECK

Start the engine and keep it running at 5,000 rpm.
Using the pocket tester, measure the DC voltage between the battery terminal ⊕ and ⊖.
If the tester reads under 13.5 V or over 16.0 V, check the AC generator no-load performance and regulator / rectifier.

⚠ CAUTION

When making this test, be sure that the battery is full-charged condition.

Standard charge	13.5 ~ 16.0 V at 5,000 rpm
------------------------	----------------------------

 **TOOL** Pocket tester : 09900-25002

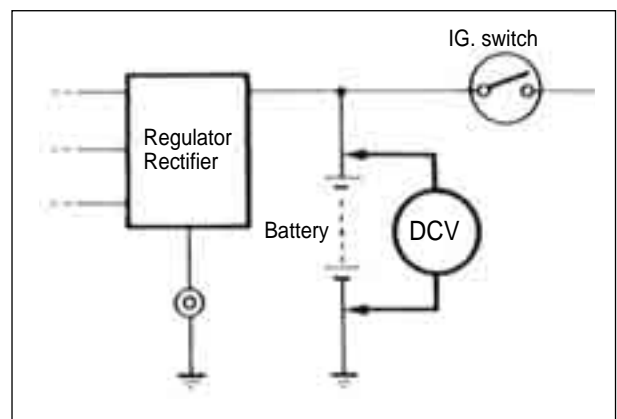

■ AC GENERATOR NO-LOAD PERFORMANCE

Disconnect the three lead wires from the AC generator terminal.
Start the engine and keep it running at 5,000 rpm.
Using the pocket tester, measure the AC voltage between the three lead wires.
If the tester reads under 72V the AC generator is faulty.

Standard NO-load performance of AC generator	72 ~ 99 V at 5,000 rpm
---	------------------------

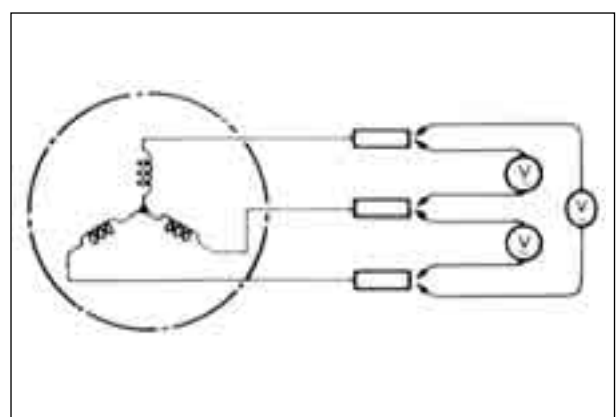

★ REGULATOR / RECTIFIER

Using the pocket tester (X 1 Ω range), measure the resistance between the lead wires in the following table.

If the resistance checked is incorrect, replace the regulator / rectifier.

Unit : k Ω

		⊕ Probe of tester				
		1	2	3	4	5
⊖ Probe of tester	1	—	OFF	OFF	OFF	OFF
	2	7-8	—	OFF	OFF	OFF
	3	7-8	OFF	—	OFF	OFF
	4	7-8	OFF	OFF	—	OFF
	5	35-55	7-8	7-8	7-8	—

 **Pocket tester : 09900-25002**

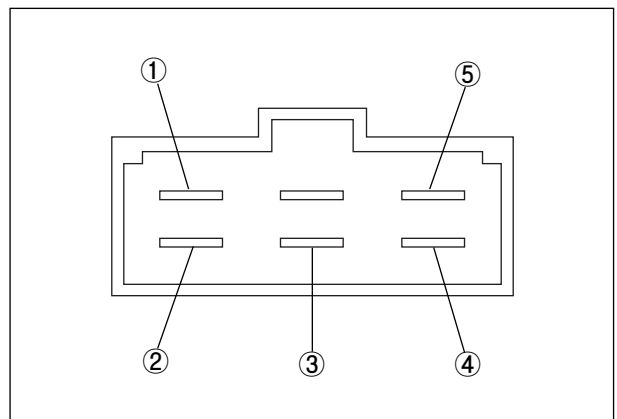
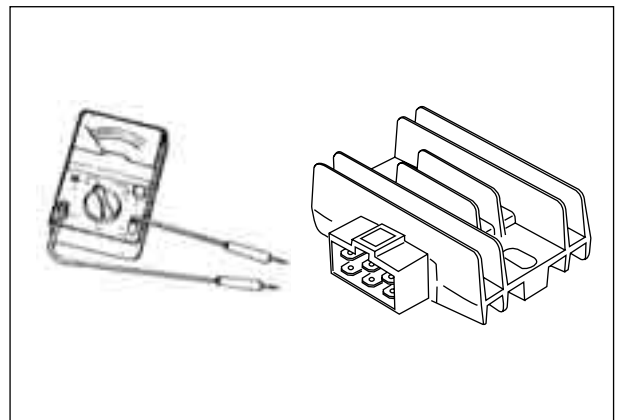

STARTER SYSTEM AND SIDE STAND IGNITION INTERLOCK SYSTEM

STARTER SYSTEM DESCRIPTION

The starter system consists of the following components : the starter motor, starter relay, clutch lever position switch, C.D.I unit, side stand switch, gear position switch, starter switch, engine stop switch, ignition switch and battery. Pressing the starter switch (on the right handlebar switch) energizes the starter relay, causing the contact points to close, thus completing the circuit from the starter motor to the battery.

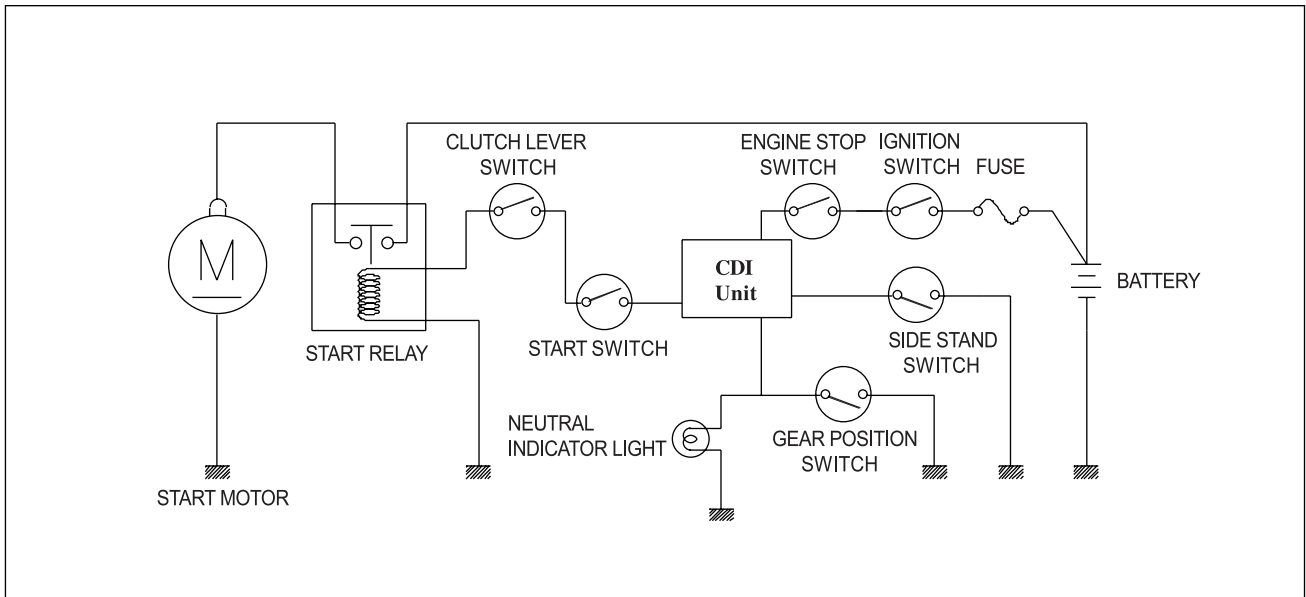

SIDE STAND / IGNITION INTERLOCK SYSTEM DESCRIPTION

This side stand / ignition interlock system prevents the motorcycle from being started with side stand down. The system is operated by an electric circuit provided between the battery and ignition coil. The circuit consists of the C.D.I unit, neutral indicator light and switches. The ignition coils will send voltage to the spark plugs dependant on what gear the transmission is in and whether the side stand is either up or down. The gear position and side stand switches work together in this system. The ignition coil work only in two situations as follows.

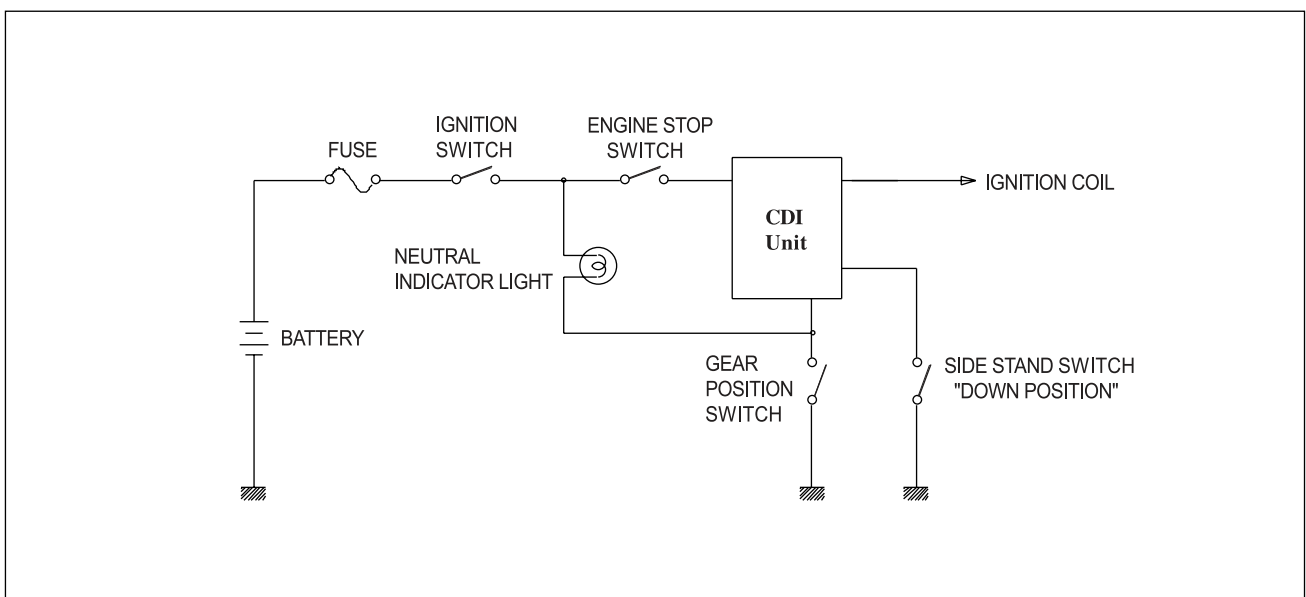

■ **TRANSMISSION** : Neutral - ON
Side stand - Down (OFF)

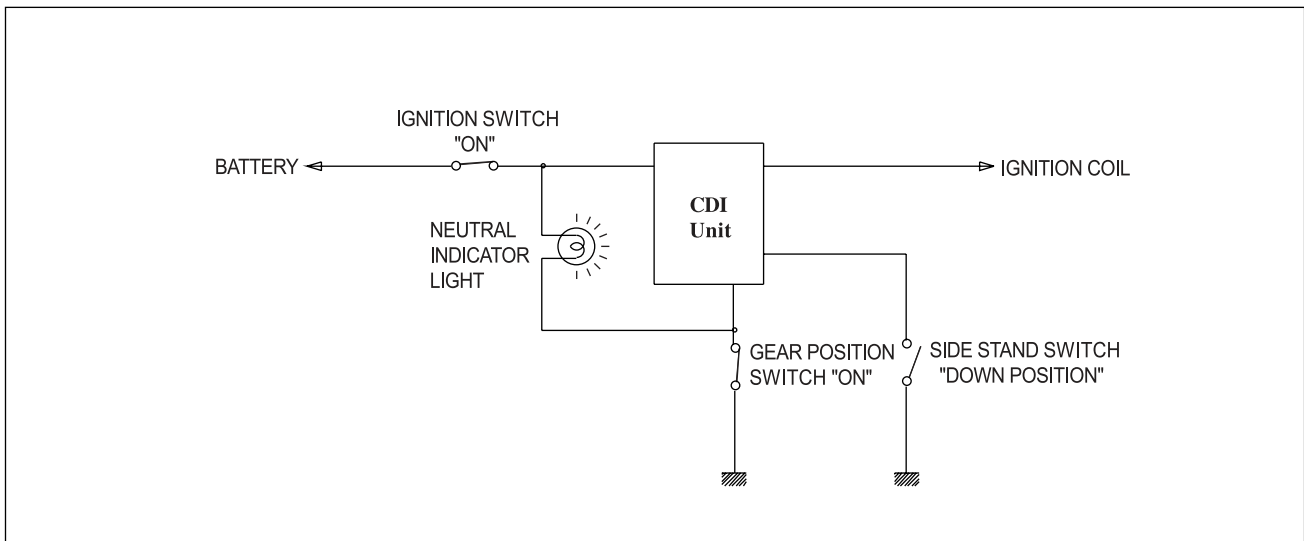

■ **TRANSMISSION** : Neutral - OFF
Side stand - Up (ON)

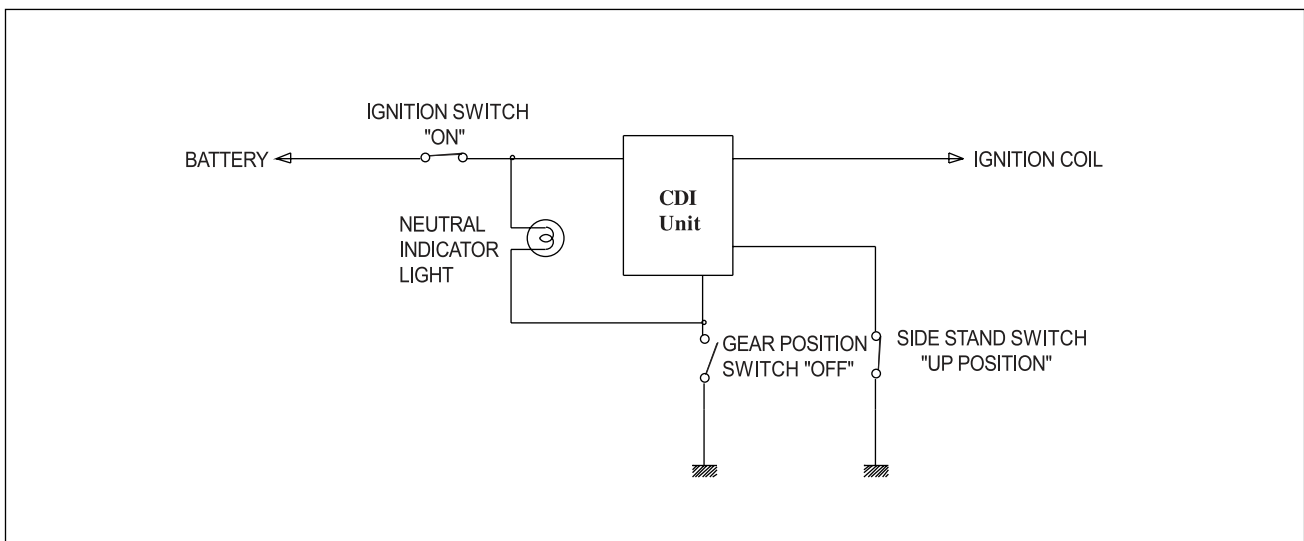

Aquila 250 is equipped with the side stand ignition interlock system.

1. If the transmission is in neutral, you can start the engine regardless of clutch lever and side stand.
2. If the transmission is not in neutral, you can only start the engine with pulling in clutch lever and side stand up.

No	Neutral switch	Clutch lever	Side stand	Engine Start
1	●	△	△	Possible
2	△	●	●	Possible
3	△	●	△	Impossible
4	△	△	●	Impossible

NOTE : ● - On or Up. △ - Off or Down

⦿ **STARTER MOTOR REMOVAL AND DISASSEMBLY**

- Disconnect the starter motor lead wire ①. (Refer to page 3-3)
- With loosen the bolt ②, remove the starter motor. (Refer to page 3-8)
- Disassemble the starter motor.



⦿ **STARTER MOTOR INSPECTION**

■ **CARBON BRUSH**

Inspect the brushes for abnormal wear, crack or smoothness in the brush holder.

If the brush has failed, replace the brush sub assy.

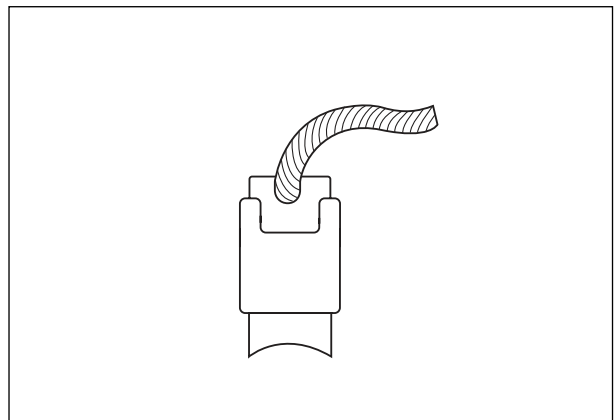

■ **COMMUTATOR**

Inspect the commutator for discoloration, abnormal wear or undercut ①.

If the commutator is abnormally worn, replace the armature.

When surface is discolored, polish it with #400 sand paper and clean it with dry cloth.

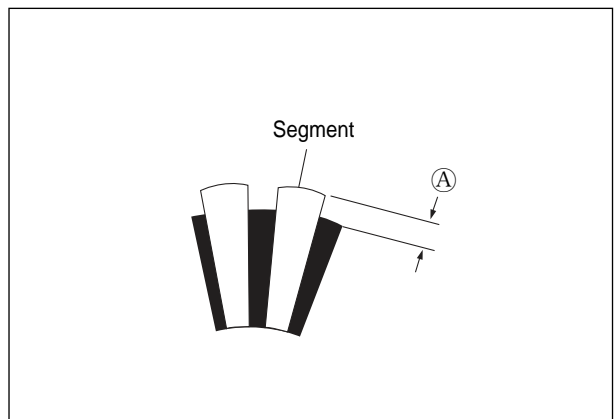

■ **ARMATURE COIL INSPECTION**

Check for continuity between each segment.

Check for continuity between each segment and the armature shaft.

If there is no continuity between the segments or there is continuity between the segment and shaft, replace the starter motor with a new one.

 **TOOL** Pocket tester : 09900-25002

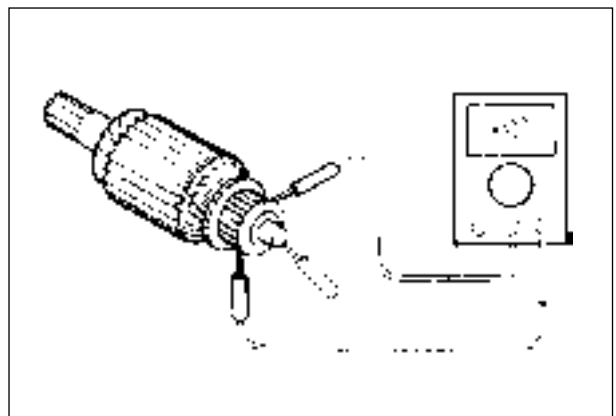

■ STARTER MOTOR REASSEMBLY

Reassembly the starter motor. Pay attention to the following points :

- Reassembly the starter motor as shown in the illustration.

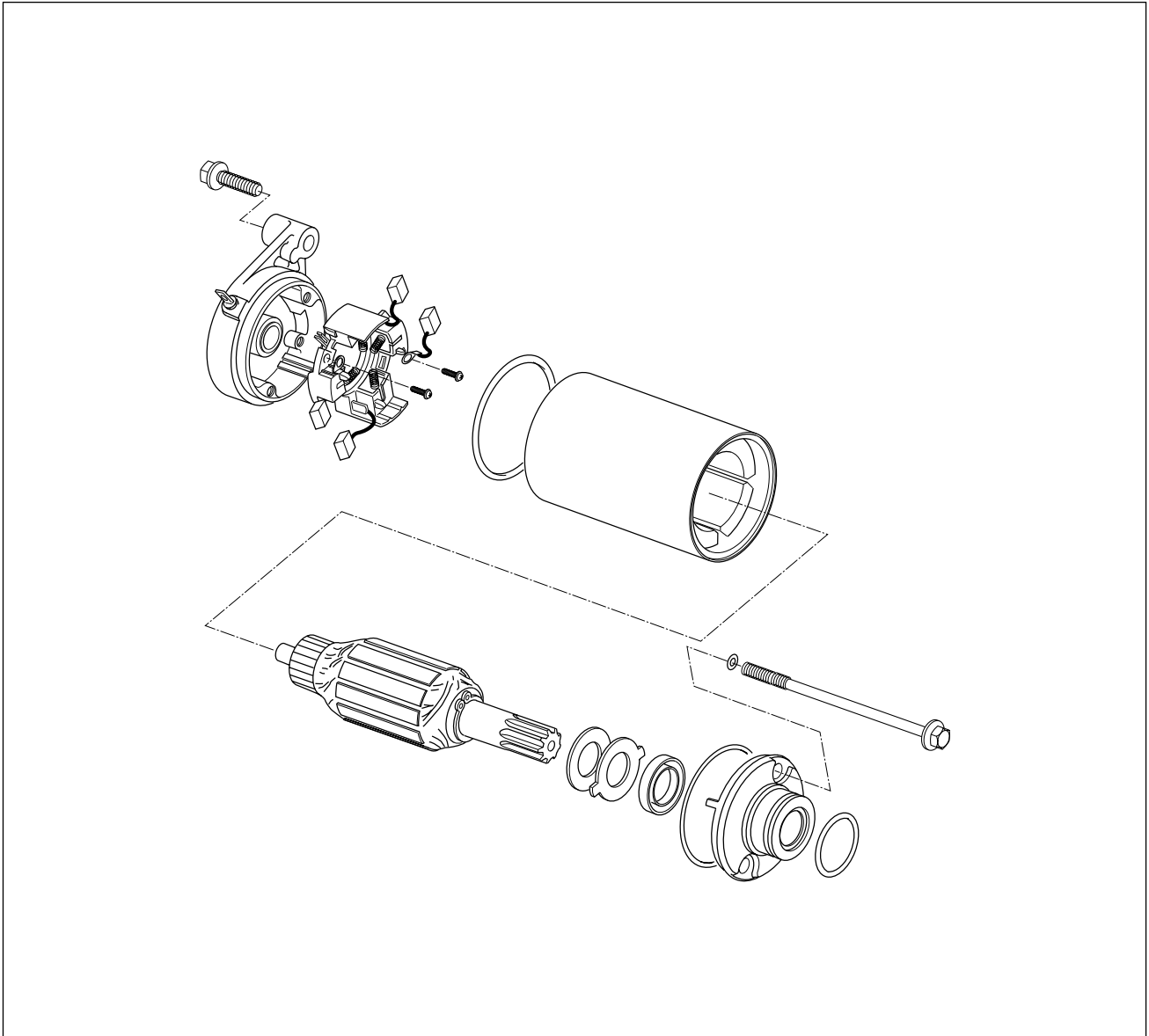

- Align the mark ① on the housing with the line ② on the housing end.

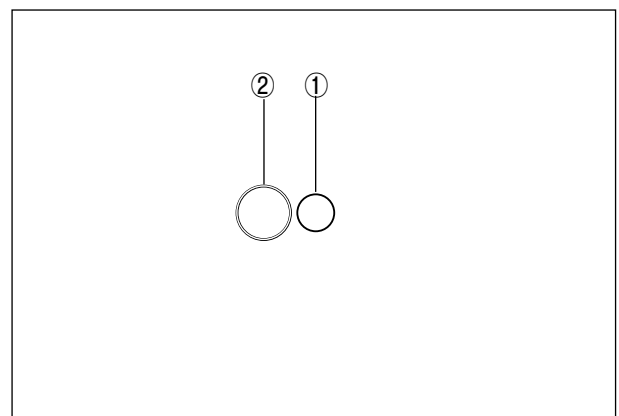

5-15 ELECTRICAL SYSTEM

- Apply SUPER GREASE “A” to the O-ring ① and remount the starter motor.

 **SUPER GREASE “A”**

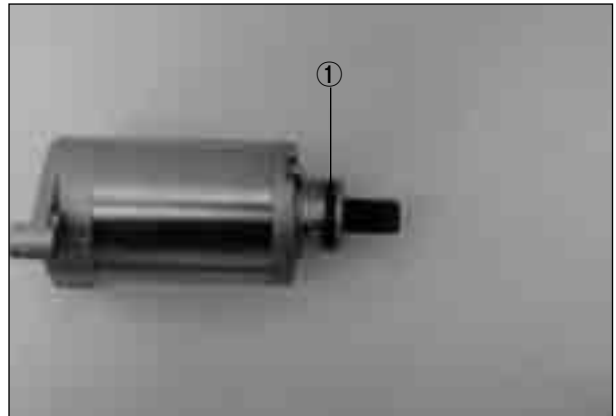





SWITCHES

Measure each switch for continuity using a tester. If any abnormality is found, replace the respective switch assemblies with new ones.

 **Pocket tester : 09900-25002**

IGNITION SWITCH				
	R	O	BW	BR
ON	○-----○			
OFF			○-----○	○-----○
LOCK			○-----○	○-----○

ENGINE STOP SWITCH		
	O	OB
	○-----○	○-----○
		

HEADLAMP SWITCH			
	O	YW	Gr
	○-----○	○-----○	○-----○
	○-----○	○-----○	○-----○
			

STARTER SWITCH		
	OB	YG
ON	○-----○	○-----○
OFF		

DIMMER SWITCH			
	YW	Y	W
HI	○-----○	○-----○	
LO	○-----○	○-----○	○-----○

HORN SWITCH		
	G	BW
ON	○-----○	○-----○
OFF		

TURN SIGNAL SWITCH			
	Lg	Sb	B
L		○-----○	
PUSH			
R	○-----○	○-----○	

FRONT/REAR BRAKE LAMP SWITCH		
	O	WB
ON	○-----○	○-----○
OFF		

LAMP

⦿ HEADLAMP

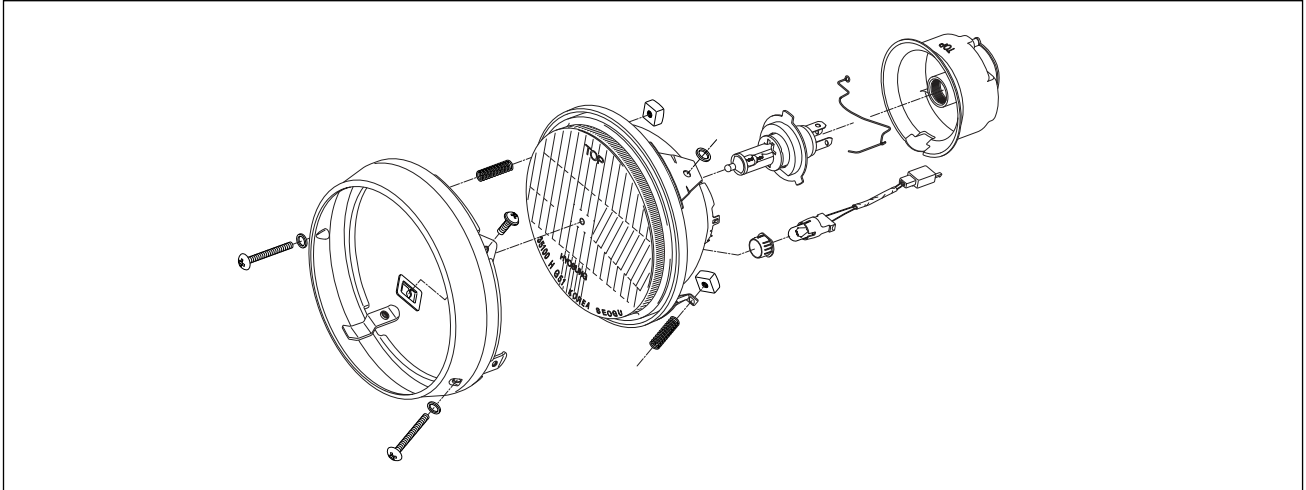

⦿ TURN SIGNAL LAMP

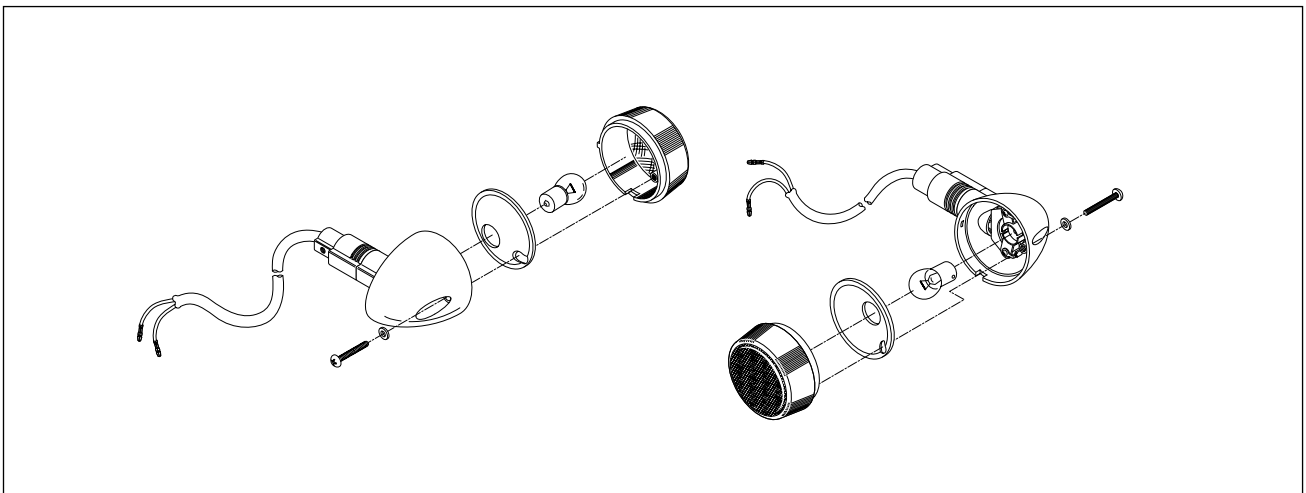

⦿ TAIL / BRAKE LAMP

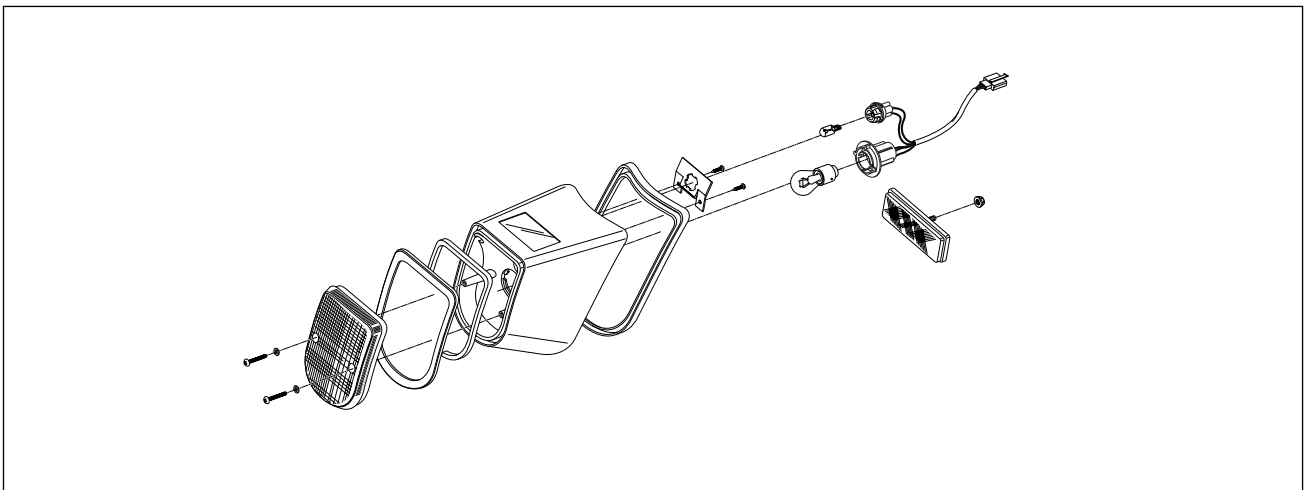

5-17 ELECTRICAL SYSTEM

⦿ COMBINATION METER

Remove the combination meter.

Disassemble the combination meter as shown in the illustration.

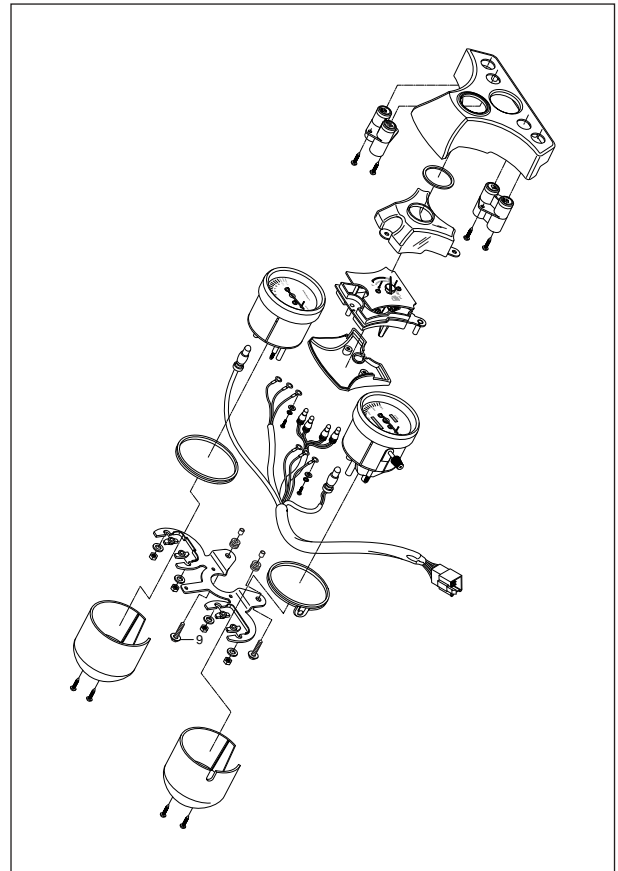

■ INSPECTION

Using the pocket tester, check the continuity between lead wires in the following illustration.

If the continuity measured incorrect, replace the respective part.

 **TOOL** Pocket tester : 09900-25002

 **CAUTION**

When making this test, it is not necessary to remove the combination meter.

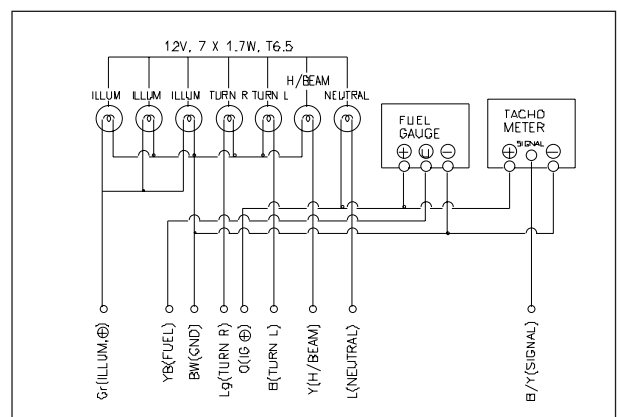

BATTERY

⊙ CAUTION OF BATTERY TREATMENT

The battery should be well taken care of because it emits flammable gas.

If you don't follow the instruction in the below, there may be an explosion and severe accident.

Therefore, please pay attention to the following points.

- Prohibit positively battery from contacting to short, spark or firearms.
- The recharge of battery should be done in the wide place where the wind is well ventilated.
Please don't recharge it at the sight of wind-proof.

⊙ CAUTION OF BATTERY ELECTROLYTE TREATMENT

- Pay attention for the battery electrolyte not to stain the chassis or the humanbody.
- If be stain the chassis or the humanbody, at once wash a vast quantity of water.
When it be stained, clothes should come into being a hole or painting should take off.
Be cured from a doctor.
- When the battery electrolyte was dropped to the surface of land, wash a vast quantity of water.
Neutralize by hudroxide, bicarbonate of soda and so on.

⊙ CAUTION OF MAINTENANCE FREE BATTERY TREATMENT

- Do not remove the aluminum tape to seal the battery electrolyte filler hole until use as battery of completely seal type.
- Do not use it except the battery electrolyte.
- When pour into the battery electrolyte, necessarily use the electrolyte of the specified capacity.
- Do not open the sealing cap after recharge the battery eletrolyte.

- Filling electrolyte.

- ① The battery is puted on even land, remove the aluminum tape sealing.
- ② Remove the cap at the electrolyte container.

⚠ CAUTION

Do not remove the seal, not prick with sharp thing.

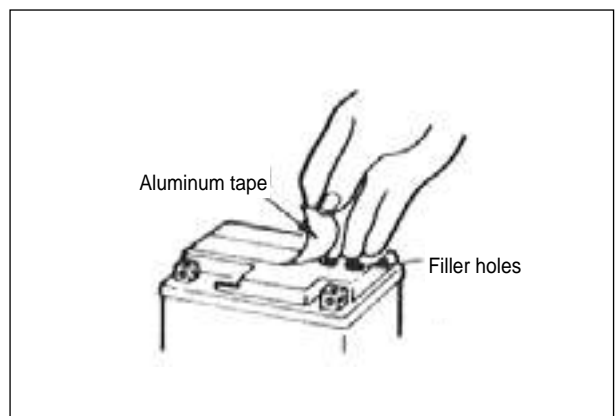
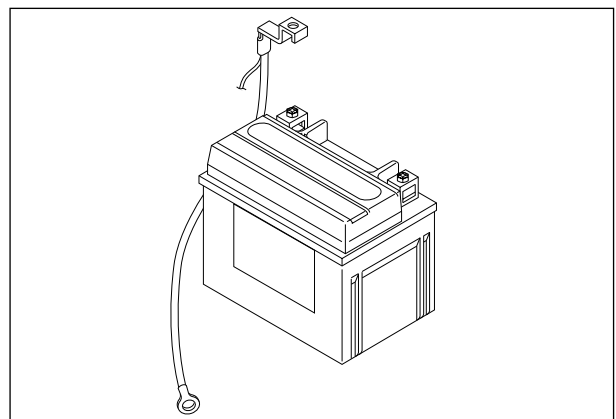

5-19 ELECTRICAL SYSTEM

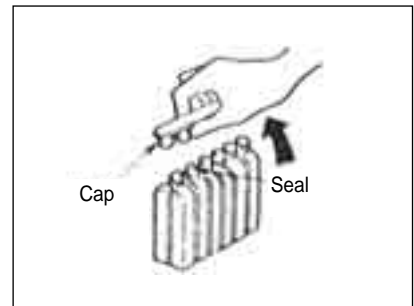
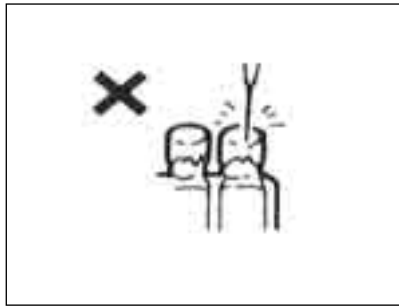
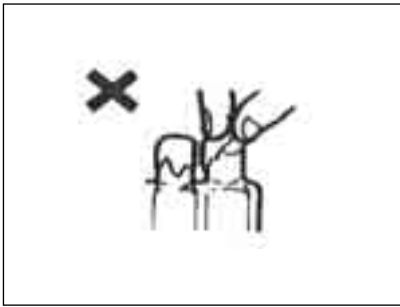

③ Pouring of battery electrolyte

When insert the nozzles of the electrolyte container into the battery's electrolyte filler holes, holding the container firmly so that it does not fall.

Take precaution not to allow any of the fluid to spill.

⚠ CAUTION

There may be a case which can't pour the electrolyte if you put it into electrolyte container slopely.

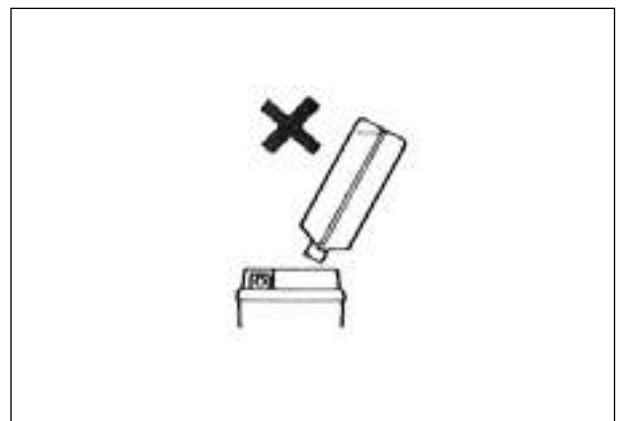
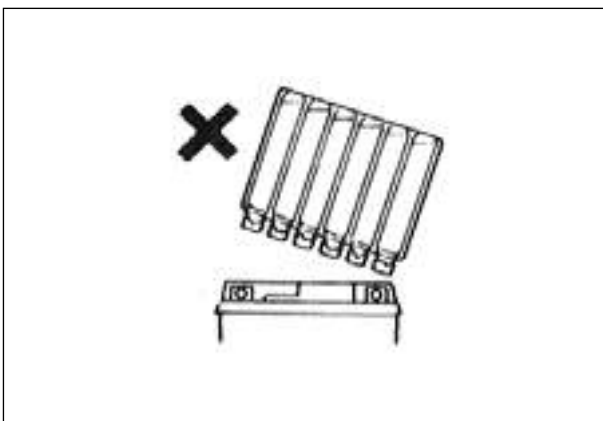
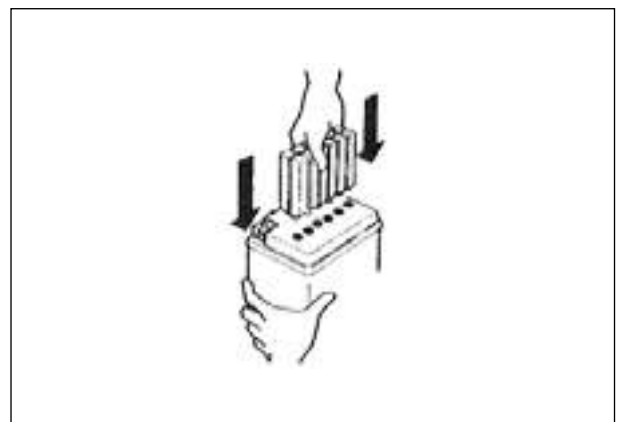

④ Confirmation of pour

Make sure that air bubbles are coming up each electrolyte container, and keep this position for about more than 20 minutes.

⚠ CAUTION

If no air bubbles are coming up from a filler port, tap the button of the two or three times.

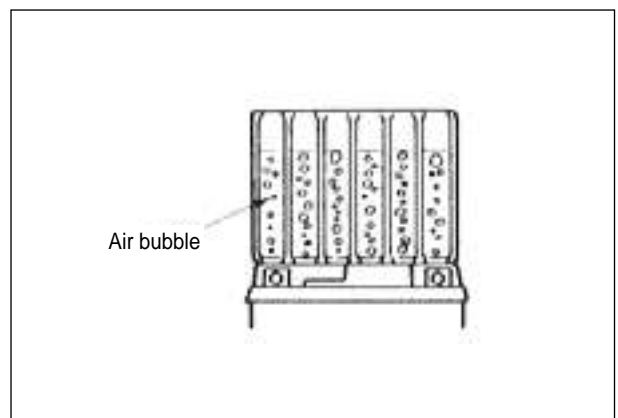

⑤ Separation of electrolyte container

After confirming that you entered the electrolyte into battery completely, remove the electrolyte containers from the battery.

⚠ CAUTION

Draw the empty receptacle out slowly because there may be a chance which remaining electrolyte vaporize.



⑥ Insert of the caps

Insert the cap into the filler holes, pressing it firmly so that the top of the caps do not protrude above the upper surface of the battery's stop cover.

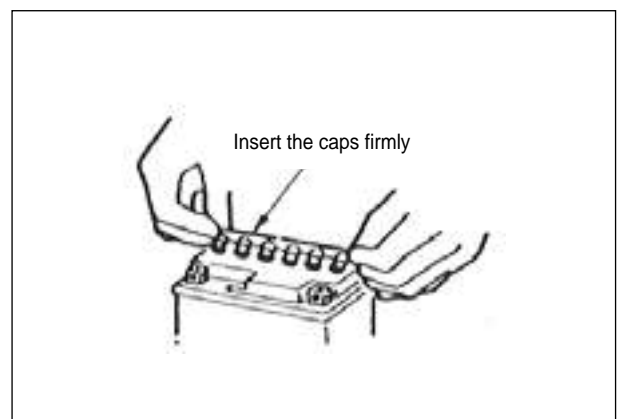

⊙ **BATTERY INSTALLATION**

Aquila 250 s battery installation order pay attention to following points :

- ① Remove the seat, right frame cover and battery support.
- ② Lay down (+) positive terminal of the battery at leftside of the battery case (on the motorcycle).
- ③ Install (+) positive lead wire at the battery terminal.
- ④ Put on the rubber cap at the (+) positive terminal of the battery.
- ⑤ Install (-) negative lead wire at the battery terminal.
- ⑥ Install the battery support and right frame cover.

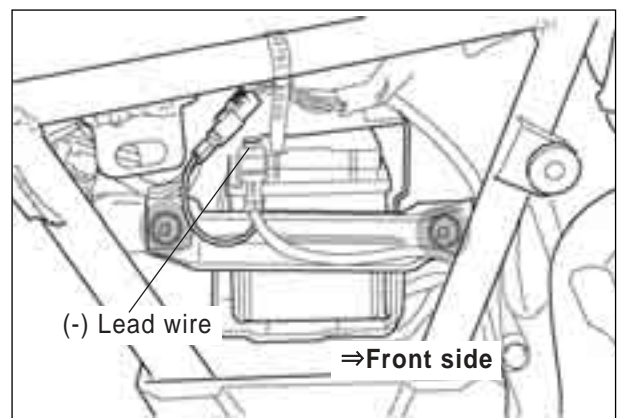

⚠ CAUTION

If install first the lead wire at the battery then lay down at the battery case, will be installed the opposite direction [(+) positive terminal face on the rightside of the motorcycle] as that length of the (+) lead wire has no something extra. This time, the battery could not lay down perfectly and to occur the short circuit etc. if the battery install the opposite direction.

5-21 ELECTRICAL SYSTEM

⊙ ASSISTANCE RECHARGING

Use the battery that is maded after 2 years as the main-tenance free battery.

Use the battery at condition of the high temperature.

Assistance recharging to the following points.

- The main principle of assistance recharging.
Assistence recharging from rule of electric current or voltage, when the battery discharged.
- Do not assistance recharge except the right side table.
- In times of recharging the battery, please do it at the condition of removal of the lead wire.

⚠ WARNING

The firearm is strictly prohibited.

Assistance Recharging	
Standard	0.7 A × 5~10 hours
Fast	3A × 30 minutes.

FUEL SYSTEM

⊙ FUEL PUMP

- Remove the left frame cover. (Refer to page 6-3)
- Remove the fuel pump lead wire coupler ①.
(Refer to page 4-2)

Using the pocket tester (X 1 Ω range), measure the resistance between the lead wires in the following table.

If the resistance checked is incorrect, replace the fuel pump.

Fuel pump resistance 1.0~10.0 Ω (BW-BG)

 **Pocket tester : 09900-25002**



⊙ FUEL PUMP RELAY

- Remove the fuel pump relay coupler ②.
(Refer to page 4-2)

Using the pocket tester (X 1 Ω range), measure the resistance between the lead wires in the following table.

If the resistance checked is incorrect, replace the fuel pump relay.

Unit : Ω

		⊕ Probe of tester			
		1	2	3	4
⊖ Probe of tester	1	—	∞	∞	∞
	2	∞	—	65~85	∞
	3	∞	65~85	—	∞
	4	∞	∞	∞	—

 **Pocket tester : 09900-25002**

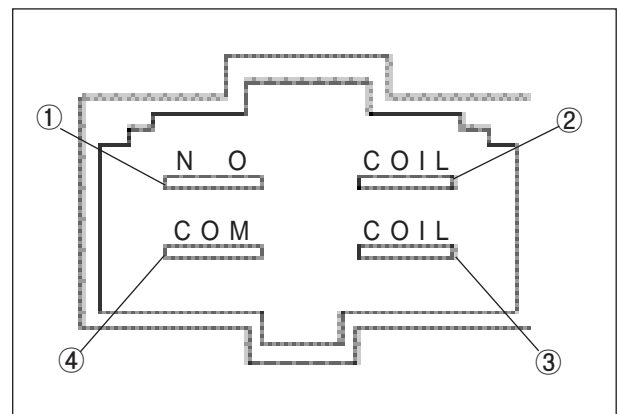

CHASSIS

CONTENTS

EXTERIOR PARTS	6- 1
FRAME COVER	6- 2
REAR FRAME COVER	6- 4
FRONT WHEEL	6- 6
FRONT BRAKE	6- 10
HANDLEBARS	6- 17
FRONT FORK	6- 19
STEERING	6- 26
REAR WHEEL	6- 32
REAR BRAKE	6- 39
REAR SHOCK ABSORBER	6- 43
SWING ARM	6- 45

EXTERIOR PARTS

⦿ FRONT FENDER

- With the bolts removed, remove the front fender.



⦿ FRONT SEAT

- Remove the front seat with the ignition key.



⦿ REAR SEAT

- With the bolts removed, remove the rear seat.

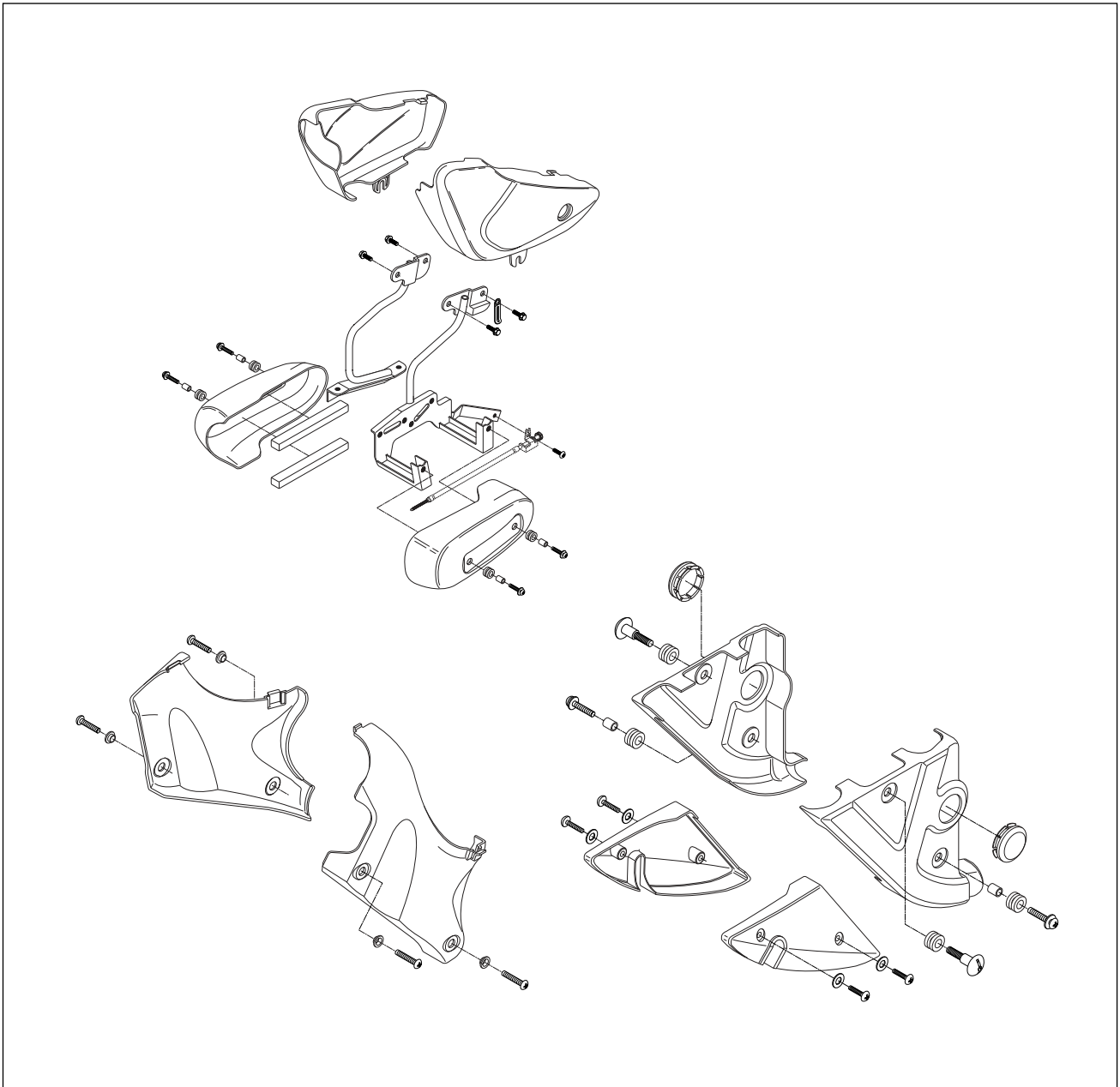

FRAME COVER**● RIGHT FRAME COVER**

- Remove the screw ①.
- With the hook ②, ③ removed, remove the right frame cover.



6-3 CHASSIS

⊙ RIGHT REAR FRAME COVER

- Remove the right frame cover.
- With the bolts ① removed, remove the right rear frame cover.

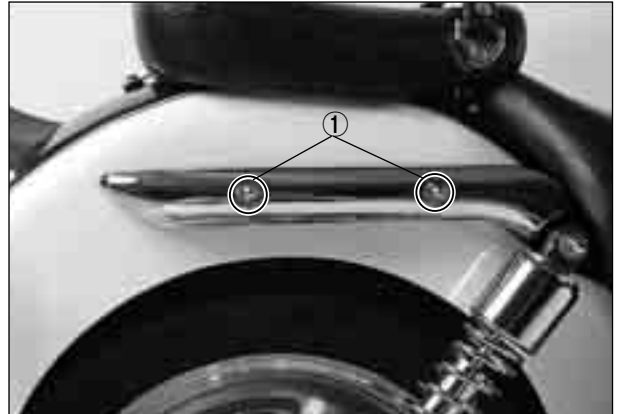

⊙ LEFT FRAME COVER

- Remove the screw ②.
- Remove the hook ③, ④.

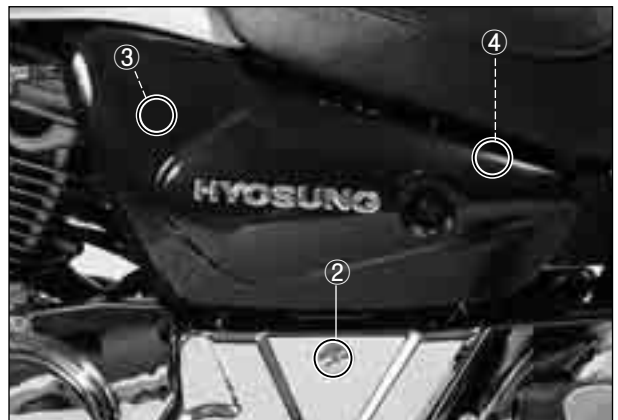

⊙ LEFT REAR FRAME COVER

- Remove the left frame cover.
- With the bolts ⑤ removed, remove the left rear frame cover.

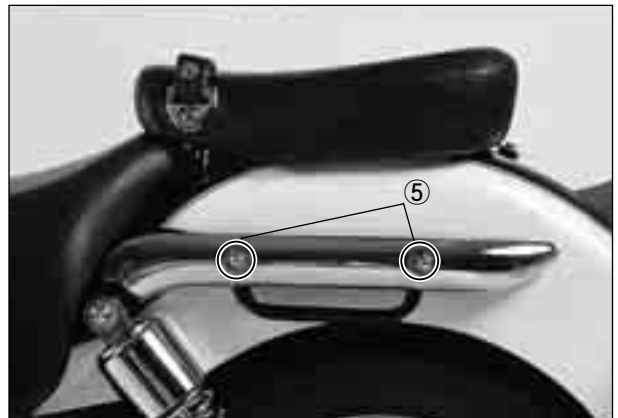

REAR FRAME COVER

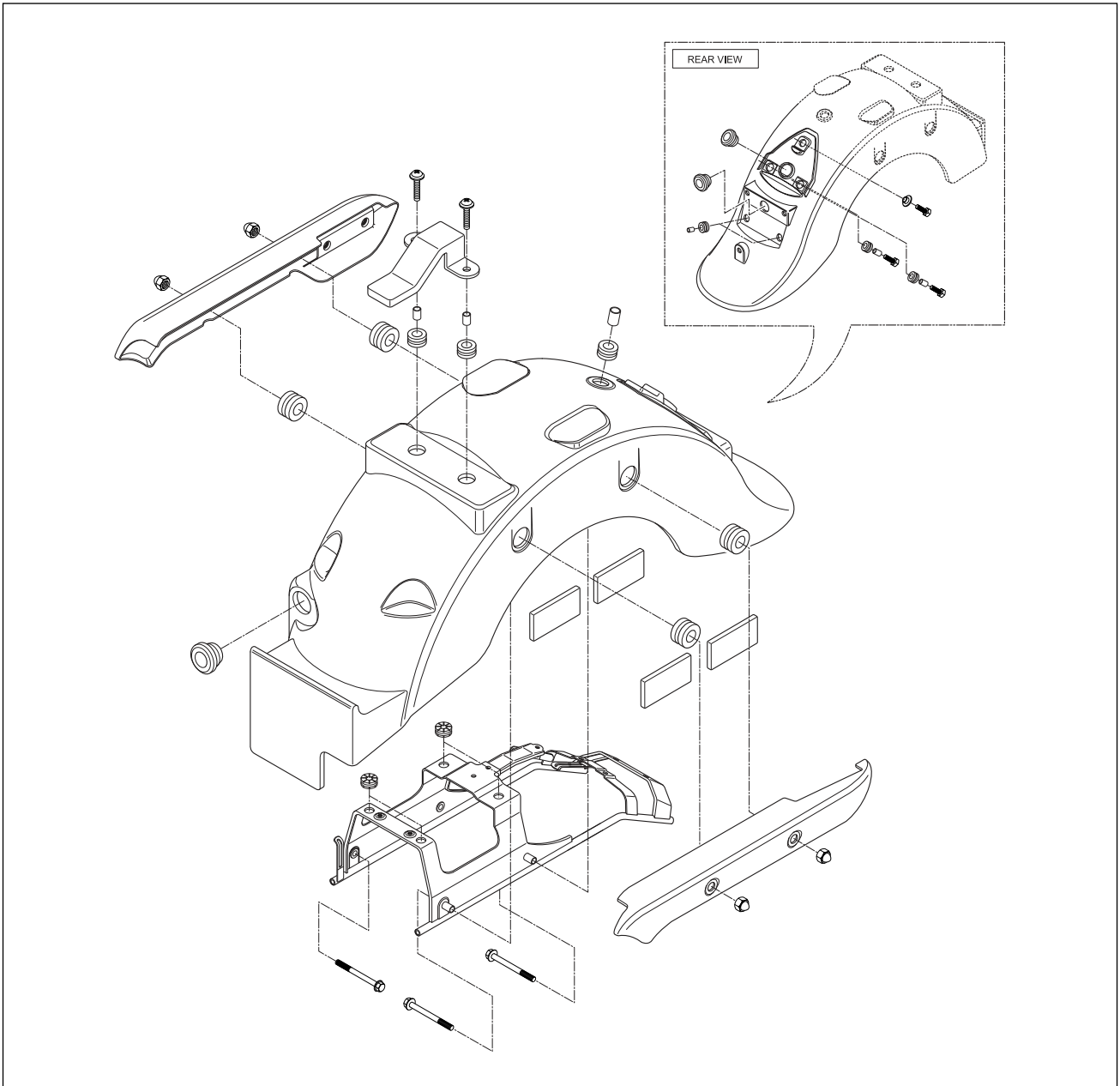

- Remove the front and rear seats.(Refer to page 6-1)
- Remove the frame covers.(Refer to page 6-2·3)
- Remove the C.D.I unit ① and rectifier / regulator ②.

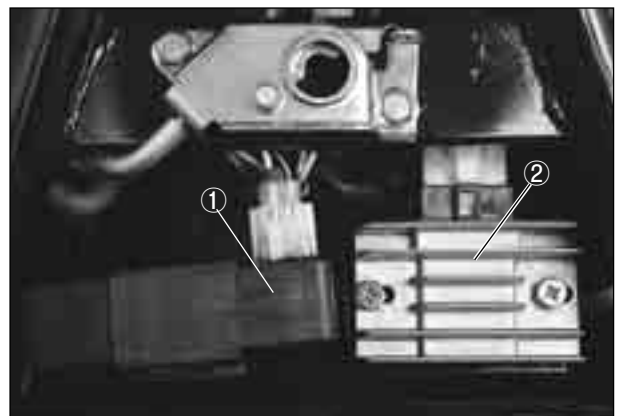

6-5 CHASSIS

- Disconnect the rear turn signal lamp couplers and rear combination lamp coupler.



- With the four bolts removed, remove the rear frame cover.

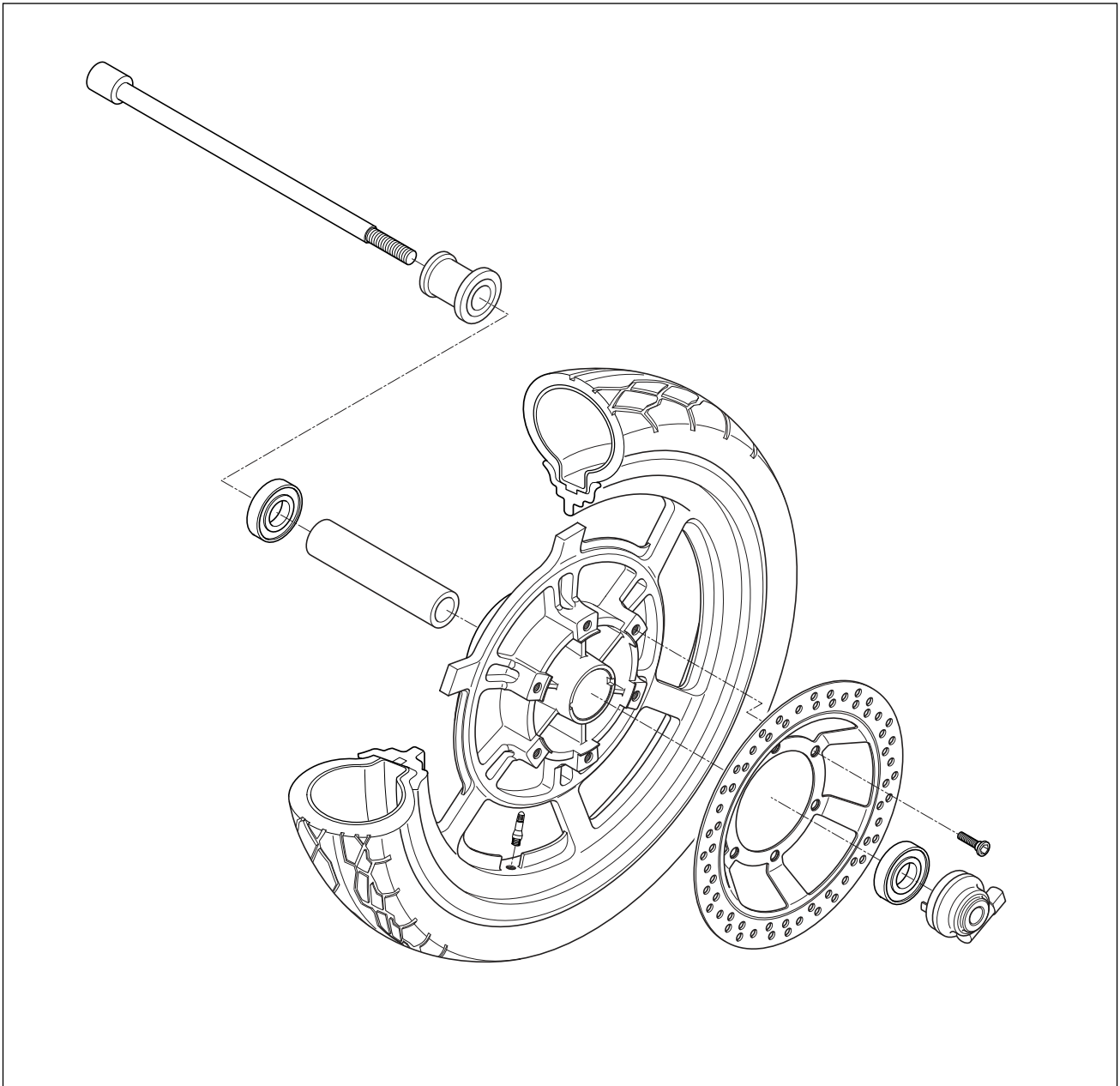

FRONT WHEEL**REMOVAL**

- Loosen the axle pinch bolt ①.
- Loosen the front axle ②.
- Raise the front wheel off the ground with a block or jack.

CAUTION

When using a jack, take care not to cause scratches on the chassis.

- Remove the front wheel by removing the front axle ②.



6-7 CHASSIS

- Remove the brake disc.



⊙ INSPECTION AND DISASSEMBLY

■ TIRE

For inspection of the tire : Refer to page 2-19.

■ FRONT AXLE

Measure the front axle runout using the dial gauge. If the runout exceeds the limit, replace the front axle.

Axle shaft runout	Service limit
	0.25 mm

-  Dial gauge : 09900-20606
- Magnetic stand : 09900-20701
- V-block : 09900-21304

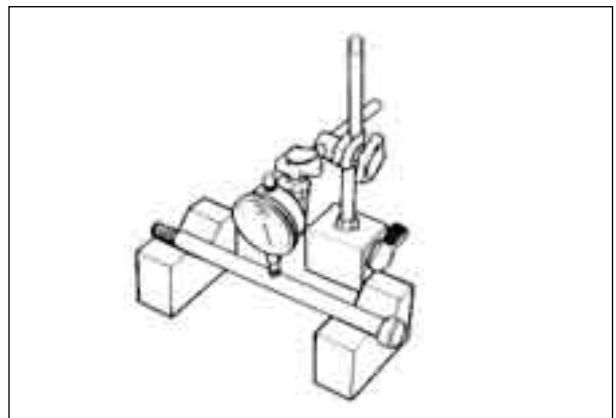

■ WHEEL

Make sure that the wheel runout (axial and radial) does not exceed the service limit when checked as shown. An excessive amount of runout is usually due to worn or loose wheel bearings and can be corrected by replacing the bearings. If bearing replacement fails to reduce the wheel.

Wheel runout (axial and radial)	Service limit
	2.0 mm

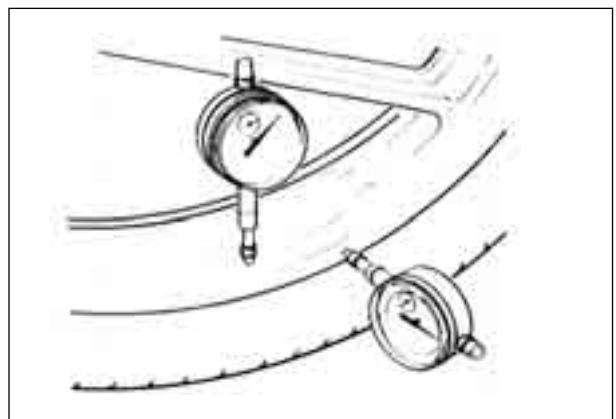

■ WHEEL BEARING

Inspect the play of the wheel bearings by finger while they are in the wheel. Rotate the inner race by finger to inspect for abnormal noise and smooth rotation. Replace the bearing in the following procedure if there is anything unusual.

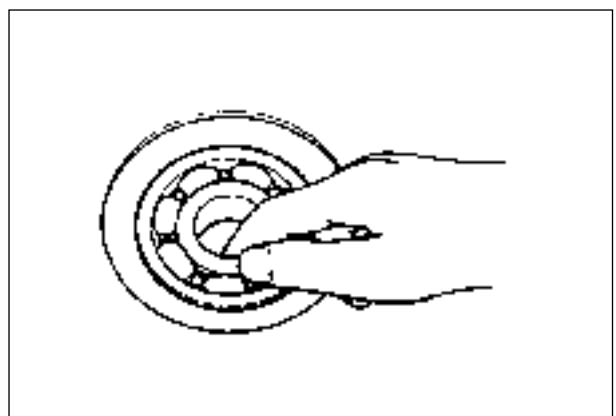

■ WHEEL BEARING REMOVAL

- Remove the wheel bearing by using the special tool.

 **Wheel bearing remover : 09941-50111**

CAUTION

The removed bearing should be replaced with new ones

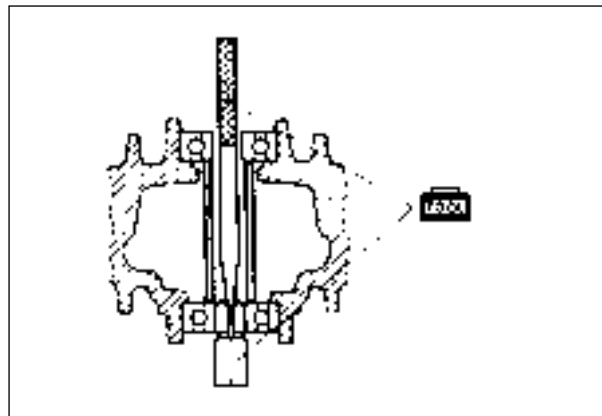

⊙ REASSEMBLY

Reassemble the front wheel in the reverse order of removal and disassembly.

Pay attention to the following points :

■ WHEEL BEARING

- Apply SUPER GREASE "A" to the wheel bearings.

 **SUPER GREASE "A"**

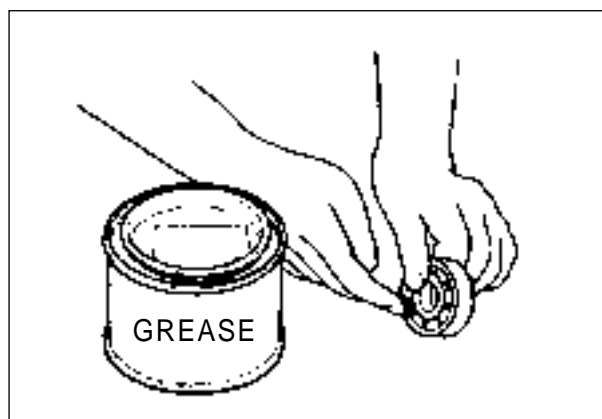

- Install the wheel bearings as follows by using the special tools.

 **Steering race installer : 09941-34513**

CAUTION

First install the right wheel bearing, then install the left wheel bearing.



■ BRAKE DISC

Make sure that the brake disc is clean and free of any greasy matter.

- Apply THREAD LOCK "1324" to the disc mounting bolts and tighten them to the specified torque.

 **Brake disc bolt : 18~28 N · m (1.8 ~2.8 kg · m)**

 **THREAD LOCK "1324"**



6-9 CHASSIS

- Tighten the front axle ① and axle pinch bolt ② to the specified torque.

- 🔧 **Front axle : 50~80 N · m (5.0 ~8.0 kg · m)**
Front axle pinch bolt : 15~25 N · m (1.5 ~2.5 kg · m)

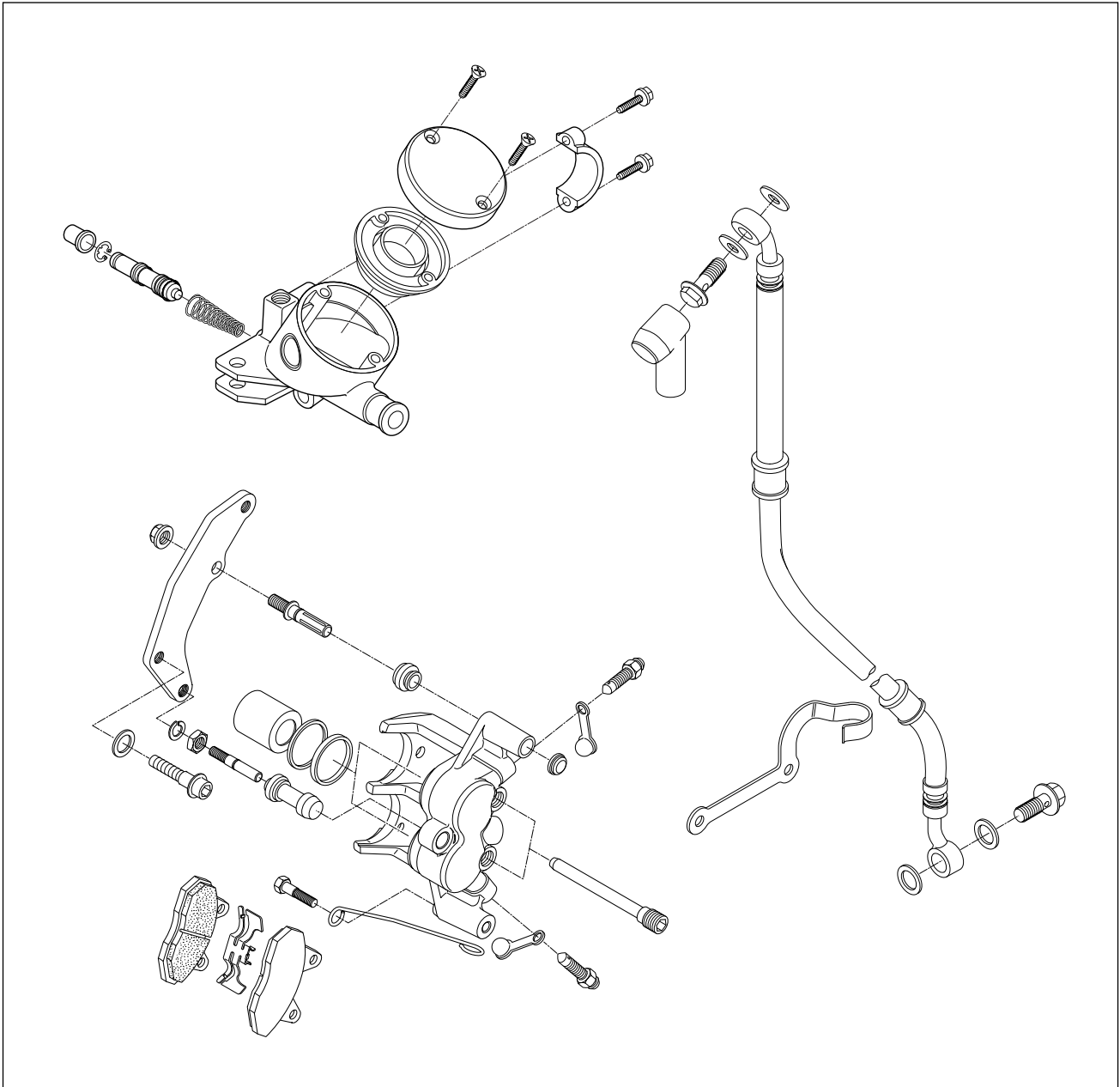

FRONT BRAKE**⚠ WARNING**

- ❖ Do not mix with brake fluid of different brand.
- ❖ Do not use a brake fluid kept in an open container or stored for long period of time.
- ❖ To store brake fluid, make sure to seal the container and keep it in a safe place to be out of reach of children.
- ❖ When filling brake fluid, take care not to allow water or dirt to enter the system.
- ❖ To wash the brake system parts, use brake fluid and not any other material.
- ❖ Do not allow dirt and fluid to contact the brake disc or pad.

⚠ CAUTION

Do not allow brake fluid to contact the paint surface, plastic or rubber parts, or its chemical reaction can cause discoloration or crack.

● **BRAKE FLUID REPLACEMENT**

● For replacing procedure of brake fluid : Refer to page 2-15

● **BRAKE PAD REPLACEMENT**

● For replacing procedure of brake pad : Refer to page 2-15

● **CALIPER DISASSEMBLY**

● Drain brake fluid. (Refer to page 2-15)

⚠ CAUTION

To prevent brake fluid from splashing on the parts nearby, cover the parts with cloth.

● Remove the union bolt ① and caliper mounting bolts ②.

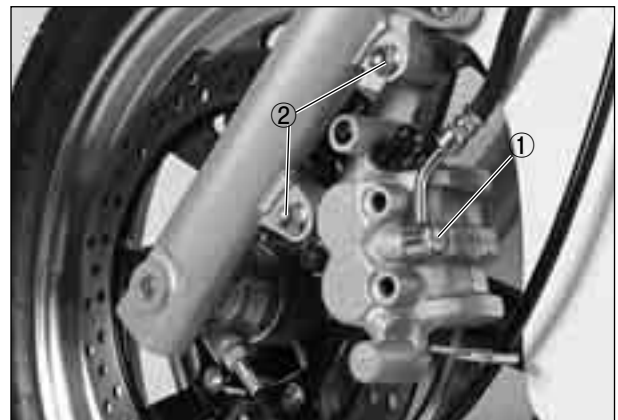

● Remove the brake pad. (Refer to page 2-15)

● Remove the brake caliper holder ③.

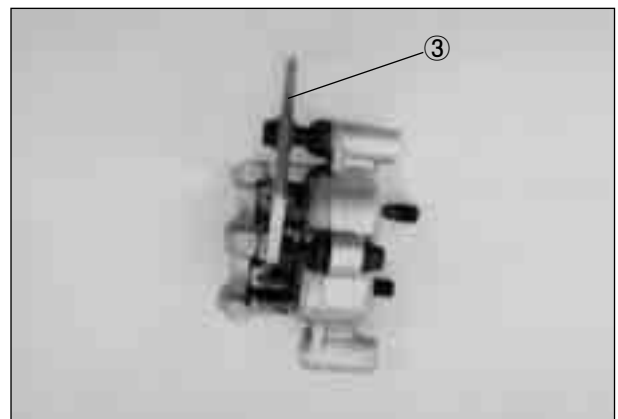

● Using an air gun, push out the caliper piston.

⚠ WARNING

- ❖ Place a rag over the piston to prevent it from popping out and flying and keeping hand off the piston.
- ❖ Be careful of brake fluid which can possibly splash.
- ❖ Do not use high pressure air but increase the pressure gradually.



- Remove the dust seal ① and piston seal ②.

⚠ CAUTION

- ❖ Care not to cause scratch on the cylinder bore.
- ❖ Do not reuse the piston seal and dust seal that have been removed.

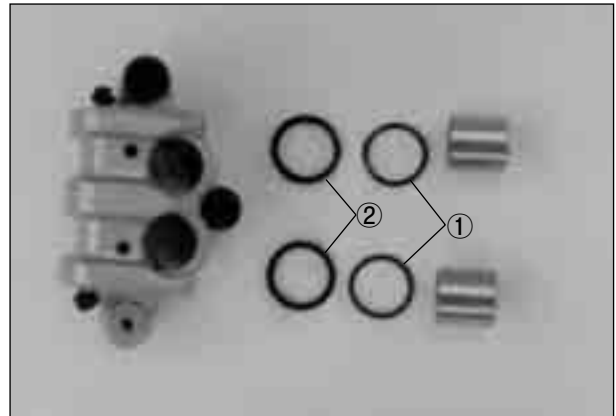

⊙ **CALIPER INSPECTION**

Inspect the caliper cylinder wall and piston surface for scratch, corrosion or other damages.
If any abnormal condition is noted, replace the caliper.



⊙ **CALIPER REASSEMBLY**

Reassemble the caliper in the reverse order of disassembly procedures and observe the following points.

⚠ CAUTION

- ❖ Wash the caliper components with fresh brake fluid before reassembly. Do not wipe off brake fluid after washing the components.
- ❖ Replace the piston seal and dust seal with new ones with brake fluid applied.



Brake fluid specification and classification
: DOT 3 or DOT 4

- Install the brake pad spring.

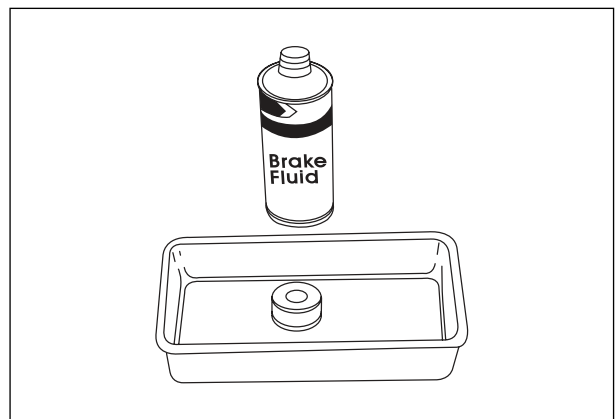

6-13 CHASSIS

- Apply SILICONE GREASE to the brake caliper holder.

SILICONE GREASE

- Install the brake pads. (Refer to page 2-15)

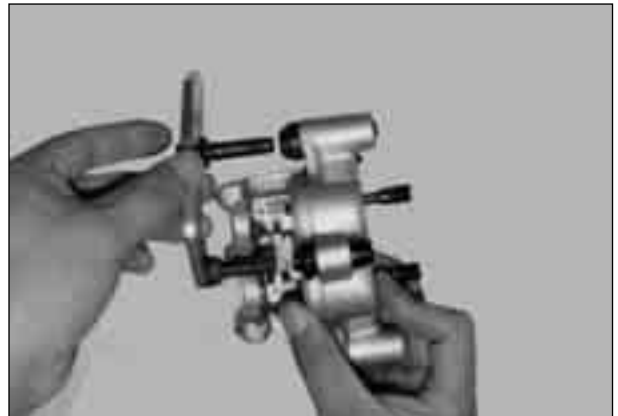

- Tighten the caliper mounting bolts ①.
- With the hose end seated to the stopper, tighten the union bolt ②.

-  **Front brake caliper mounting bolts**
 :18~28 N · m (1.8~2.8 kg · m)
- Front brake hose union bolts**
 :20~25 N · m (2.0~2.5 kg · m)

- Fill the system with brake fluid and bleed air. (Refer to page 2-16)
 Inspection after reassembly : Refer to page 2-14



⊙ BRAKE DISC INSPECTION

Check the brake disc for damage or cracks. Measure the thickness using the micrometer.

Replace the brake disc if the thickness is less than the service limit or if damage is found.

Brake disc thickness	Service limit
	3.0 mm

 **Micrometer (0 ~ 25 mm) : 09900-20201**

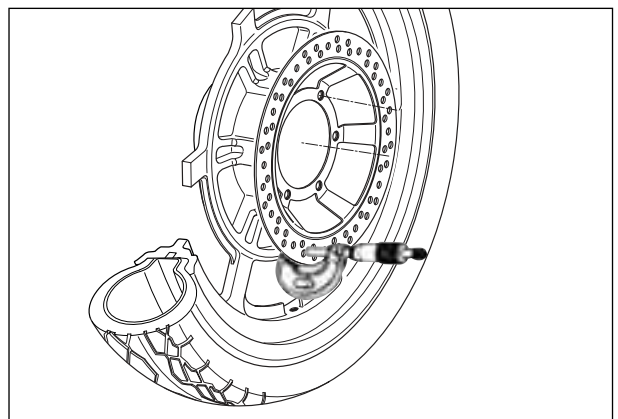

Measure the runout using the dial gauge.

Replace the brake disc if the runout exceeds the service limit.

Brake disc runout	Service limit
	0.3 mm

 **Dial gauge : 09900-20606**
Magnetic stand : 09900-20701

- If either measurement exceeds the service limit, replace the brake disc. (Refer to page 6-7)

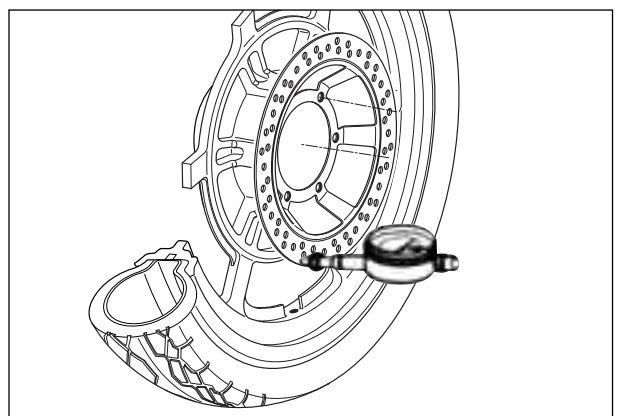

⊙ MASTER CYLINDER DISASSEMBLY

- Drain brake fluid the master cylinder.
- Disconnect the brake lamp switch lead wire coupler.
- Remove the union bolt ①.

⚠ CAUTION

Place a rag under the union bolt so that brake fluid can not contact the parts.

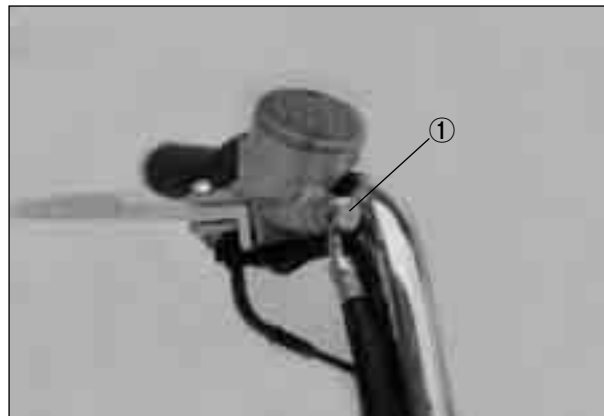

- Remove the master cylinder.



- Remove the brake lamp switch ② and brake lever ③.

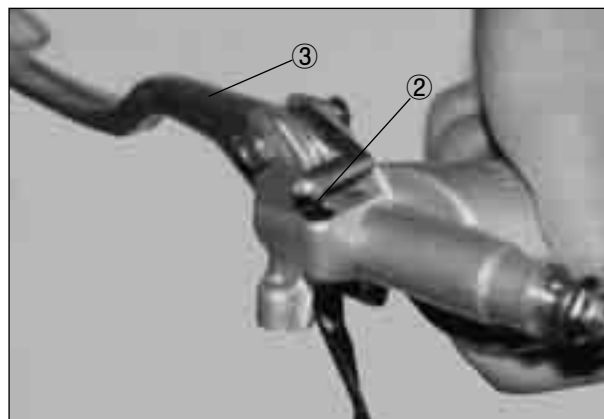

- Remove the master cylinder cap.



6-15 CHASSIS

- Detach the dust seal boot ① and remove the circlip.
- Pull out the piston/cup set ② and spring ③.

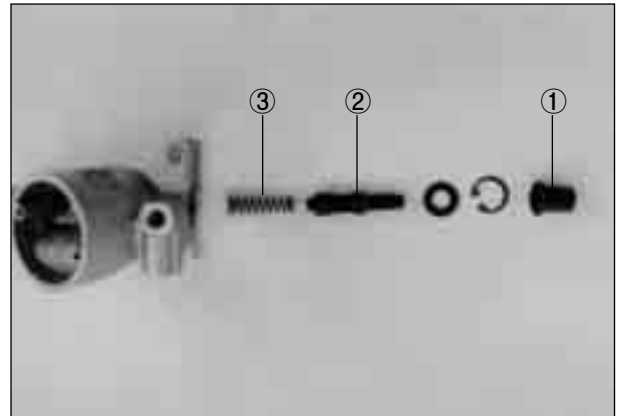

⦿ MASTER CYLINDER INSPECTION

Inspect the master cylinder bore for any scratches or other damage.

Inspect the piston surface for any scratches or other damage.

⦿ MASTER CYLINDER REASSEMBLY

Reassemble the master cylinder in the reverse order of disassembly.

Pay attention to the following points :

⚠ CAUTION

- ❖ Wash the master cylinder components with new brake fluid before reassembly.
- ❖ When washing the components, use the specified brake fluid. Never use different types of fluid or cleaning solvents such as gasoline, kerosene, etc.



Specification and Classification

: DOT 3 or DOT 4

NOTE:

When installing the circlip, make sure that the sharp edge of the circlip faces outside.

- When reinstalling the brake lamp switch, align the projection on the switch with the hole in the master cylinder.

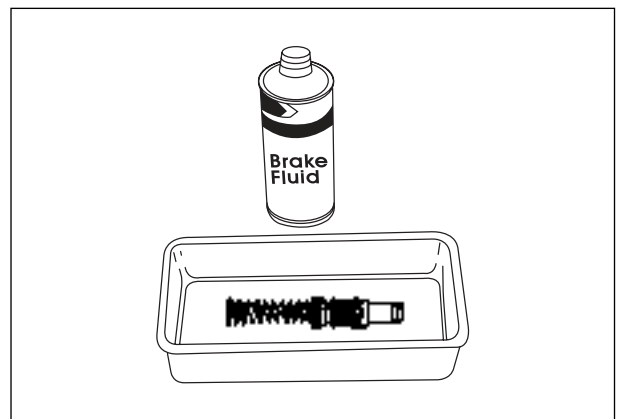
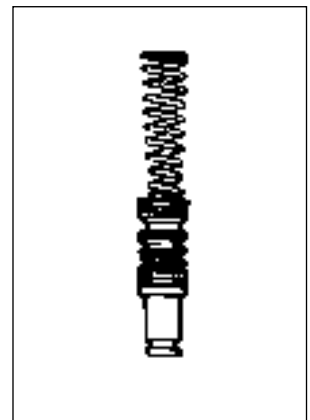
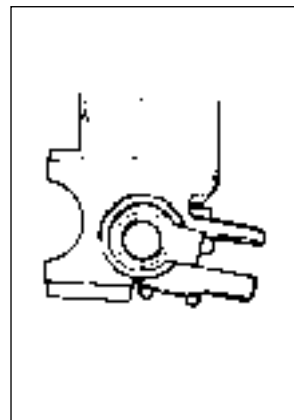

- Apply SUPER GREASE "A" to the brake lever pivot.

 SUPER GREASE "A"



- When remounting the master cylinder onto the handlebars, align the master cylinder holder's mating surface ① with punch mark ② on the handlebar and tighten the upper clamp bolt first.

 Front brake master cylinder mounting bolt
: 5~8 N · m (0.5 ~0.8 kg · m)

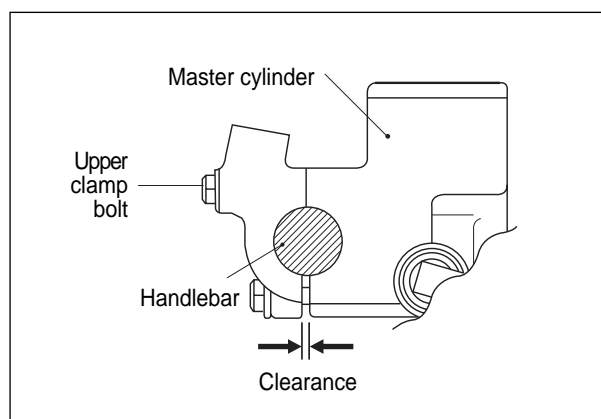
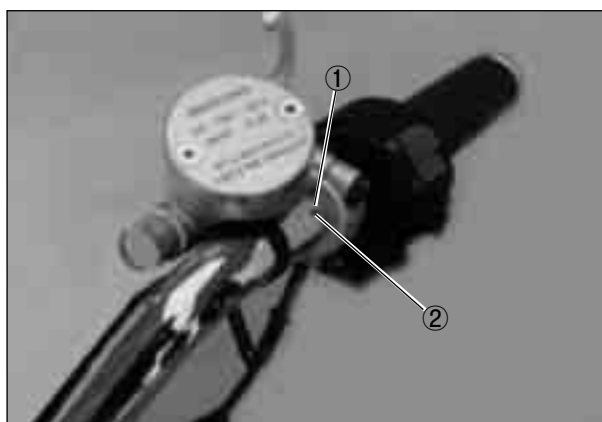

- Install the brake hose union, tighten the union bolt to the specified torque.

 Front brake hose union bolt
: 20~25 N · m (2.0 ~2.5 kg · m)

 CAUTION

Bleed air from the brake system after reassembling the master cylinder. (Refer to page 2-16)

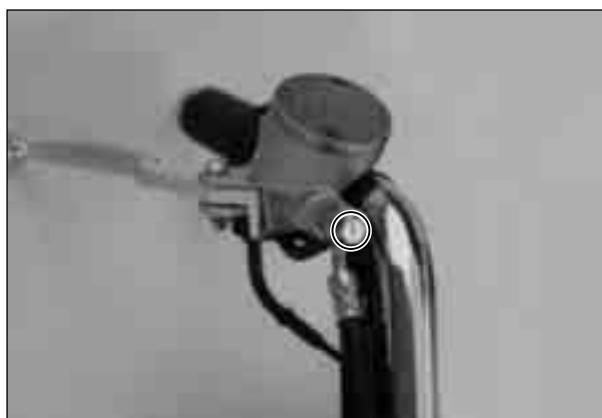

HANDLEBARS

⊙ HANDLEBARS RIGHT SIDE PARTS REMOVAL

- Remove the right handlebar switches.
- Disconnect the brake lamp switch lead wires and remove the master cylinder. (Refer to page 6-14)
- Remove the handlebar balancer ① and grip ②.

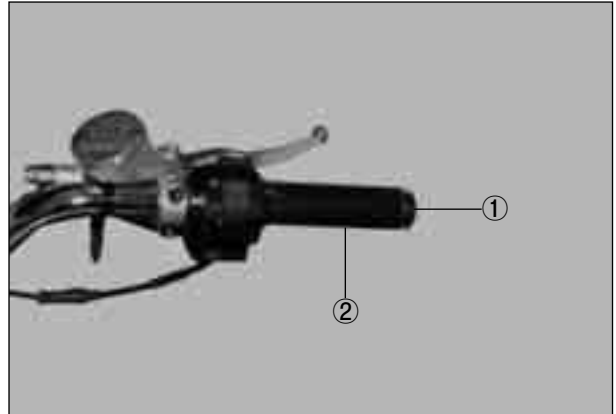

⊙ HANDLEBARS LEFT SIDE PARTS REMOVAL

- Remove the left handlebar switches.
- Remove the handlebar balancer ③ and grip ④.
- Remove the clutch lever holder.

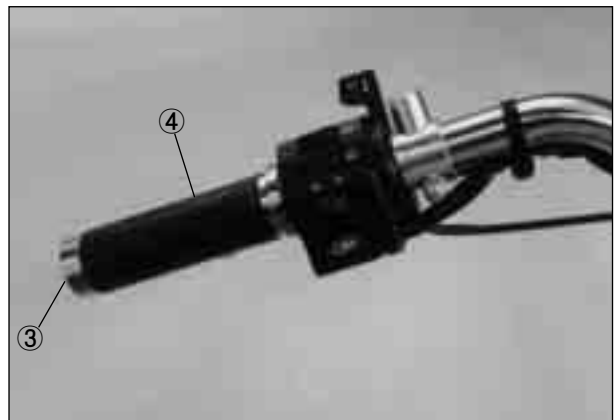

- Remove the clamp bolts and detach the handlebar holders.
- Remove the handlebar.



⊙ REMOUNTING

Perform the remounting work in the reverse order of the removal procedures while observing the following instructions.

- Install the handlebars with the punch mark ⑤ aligned with the handlebar clamp as shown.
- Tighten the handlebar clamp bolts to the specified torque.

 **Handlebar clamp bolt**
: 18~28 N · m (1.8 ~2.8 kg · m)



NOTE:

The gap ① between the handlebar clamp and holder should be even.

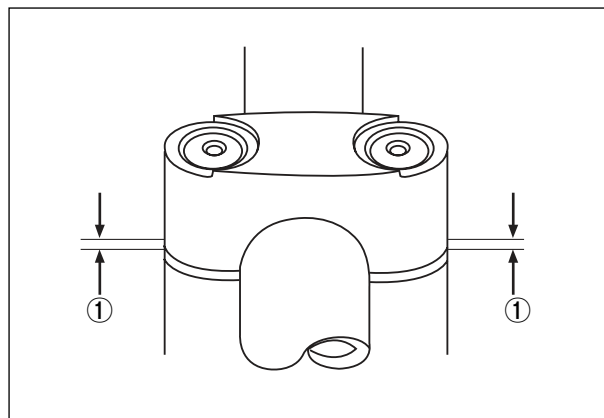

- Align the mating face of clutch lever holders with the respective punch marks and tighten the bolt.



- Install the brake master cylinder. (Refer to page 6-15).
- Apply SUPER GREASE "A" to the throttle cables and assemble them.

 SUPER GREASE "A"



FRONT FORK

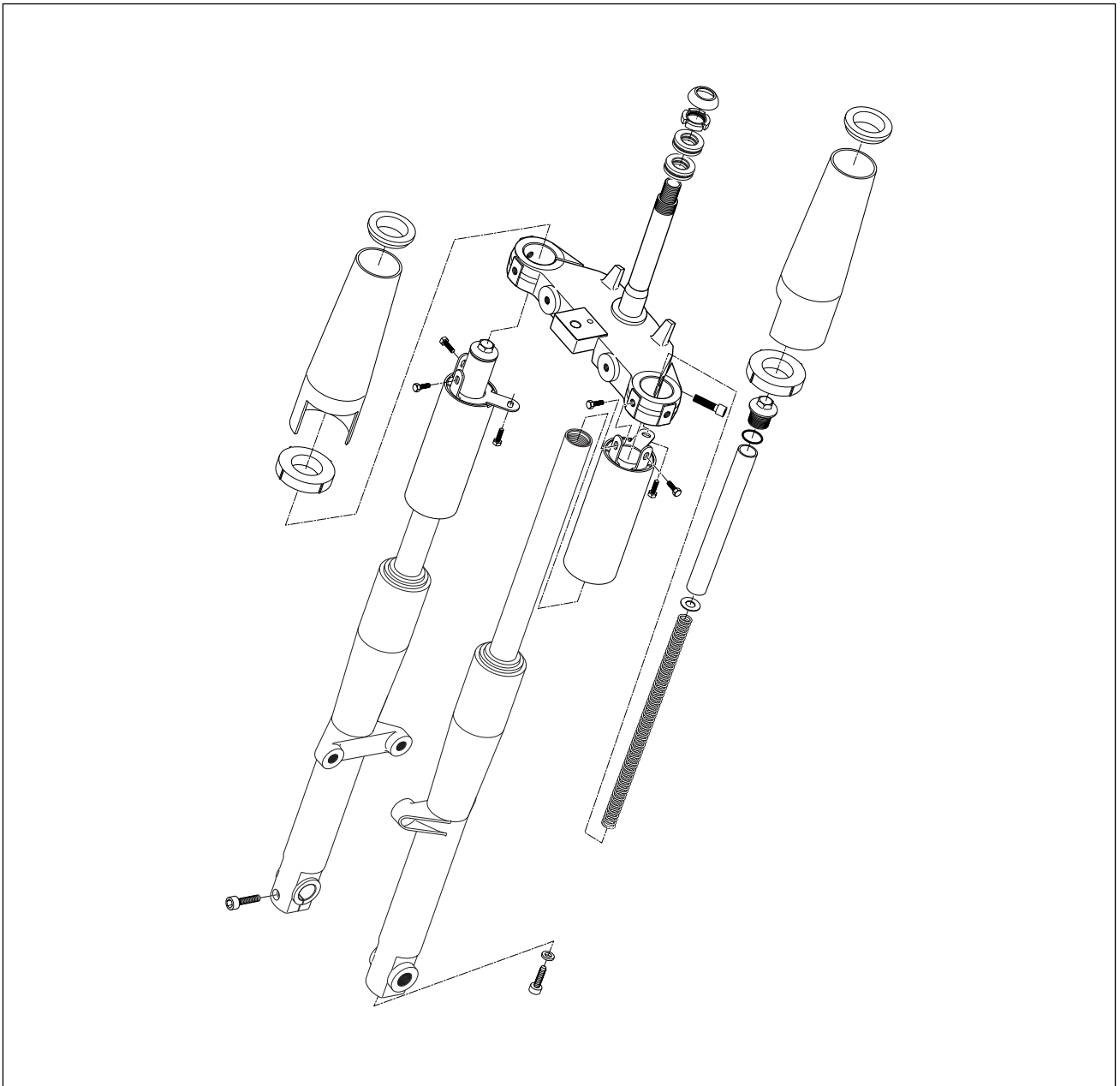

● DISASSEMBLY

- Remove the front wheel. (Refer to page 6-6)
- Remove the brake caliper. (Refer to page 6-11)

▲ CAUTION

Secure the brake caliper to the frame with a string etc., taking care not to bend the brake hose.

- Remove the front fender. (Refer to page 6-1)

- Remove the front fork after loosening the front fork upper ① and lower ② clamp bolts .

NOTE:

Slightly loosen the front fork upper bolt ③ to facilitate later disassembly.

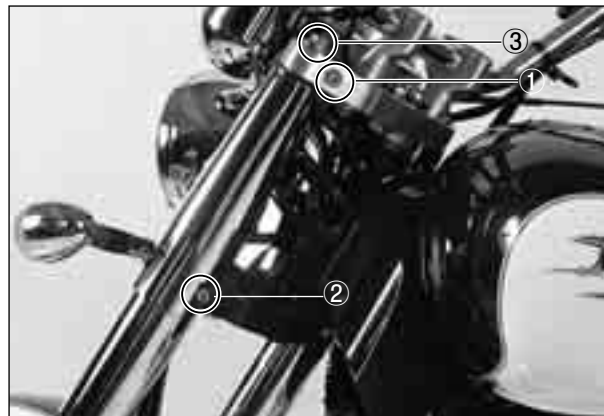

- Remove the front fork upper bolt ③, O-ring ④, front fork inner spacer ⑤ and spring guide ⑥.

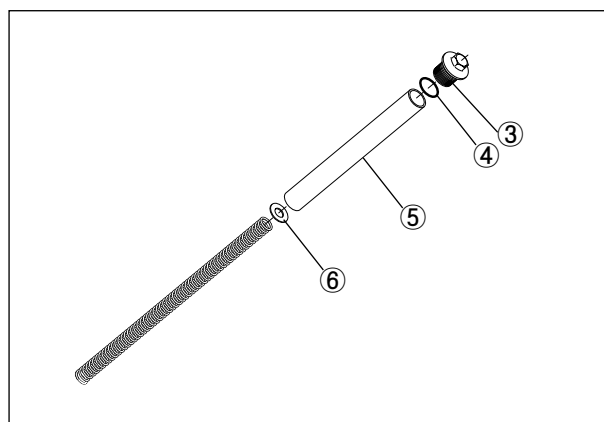

- Invert the front fork and stroke it several times to drain out the fork oil.
- Hold the front fork in the inverted position for a few minutes to allow the fork oil to fully drain.

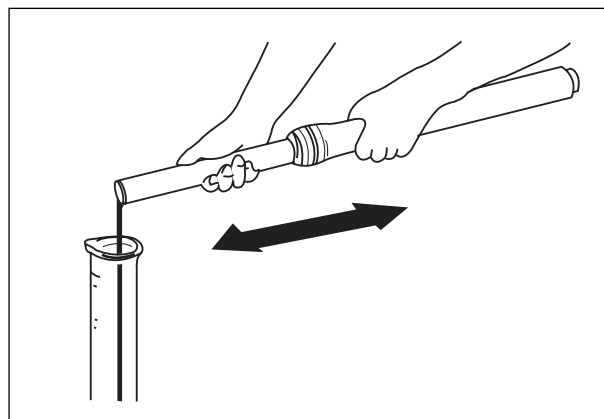

- With the damper rod held immovable, remove the damper rod bolt.
- Remove the damper rod ⑦ and rebound spring ⑧ from the inner tube.

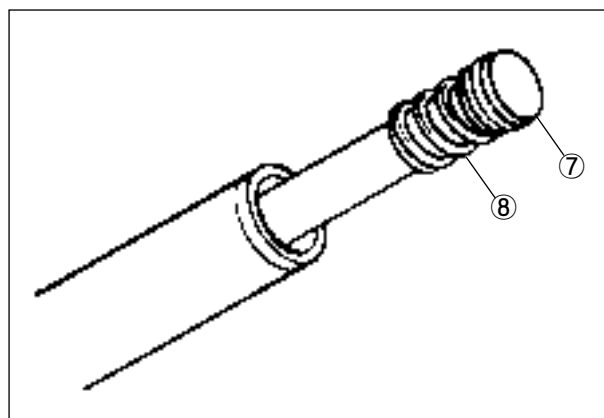

6-21 CHASSIS

- Remove the dust seal ① and oil seal stopper ring ②.

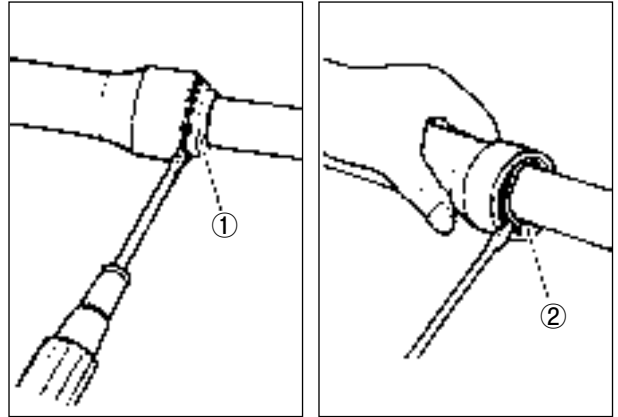

- Separate the inner tube from the outer tube.

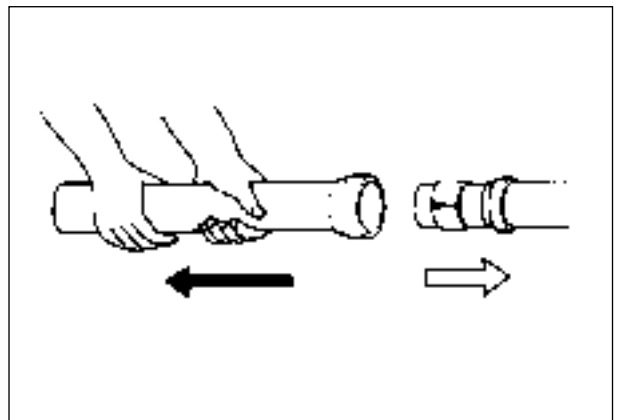

- Remove the following parts.
 - ③ Oil seal
 - ④ Slide metal
 - ⑤ Oil lock piece

⚠ CAUTION

The removed oil seal and slide metal should be replaced with new ones.

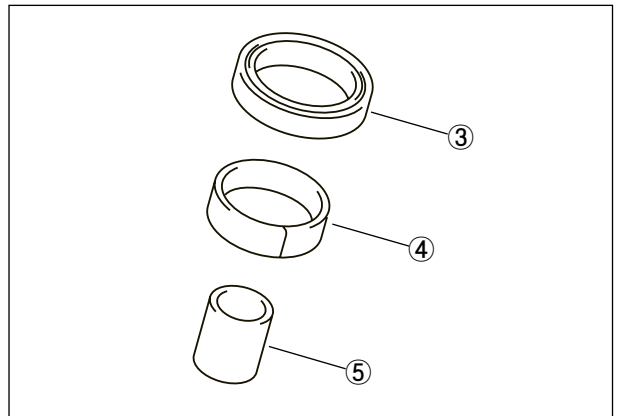

- Remove the front fork cover bolt.

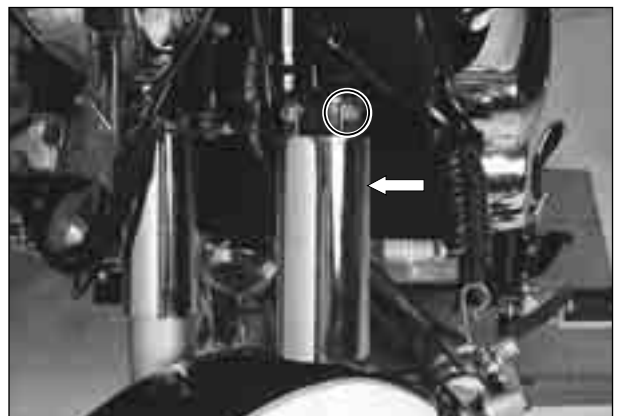

⦿ INSPECTION

■ FRONT FORK SPRING

Measure the free length of the front fork spring ①. If the length is found shorter than the service limit, replace the spring.

Front fork spring free length ①	Service limit
	356 mm

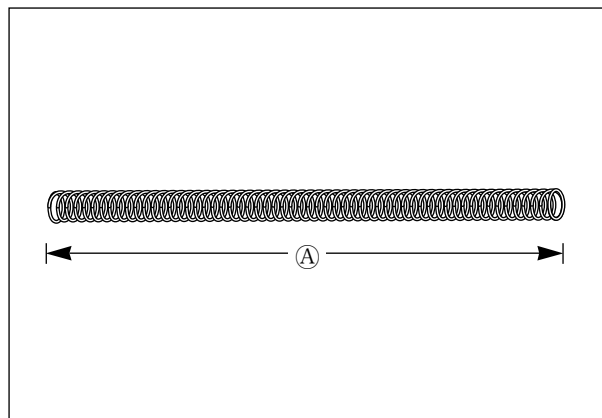

■ INNER TUBE AND OUTER TUBE

Check the sliding of the inner tube, outer tube and damper rod ring for scratch, wear, bending, or other abnormal condition.

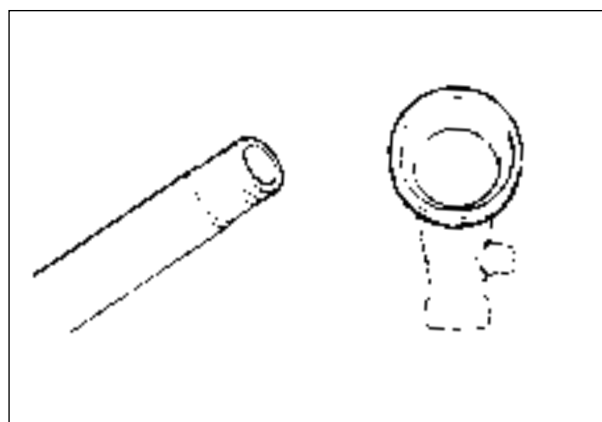

⦿ REASSEMBLY

Perform the reassembly and remounting work in the reverse order of the disassembly and removal procedures while observing the following instructions.

⚠ CAUTION

- ❖ Thoroughly wash all the component parts being assembled.
Insufficient washing can result in oil leakage or premature wear of the parts.
- ❖ When reassembling the front fork, use new fork oil.
- ❖ Use the specified fork oil for the front fork.
- ❖ When reassembling, replace the slide metals, oil seal, dust seal and damper rod bolt gasket with new ones.

● On the inner tube, assemble the following parts.

- ① Dust seal
- ② Oil seal stopper ring
- ③ Oil seal
- ④ Oil seal retainer
- ⑤ Slide metal
- ⑥ Guide bushing

⚠ CAUTION

To prevent the lip of oil seal ③ from being damaged, cover the inner tube with vinyl sheet ① during installation.

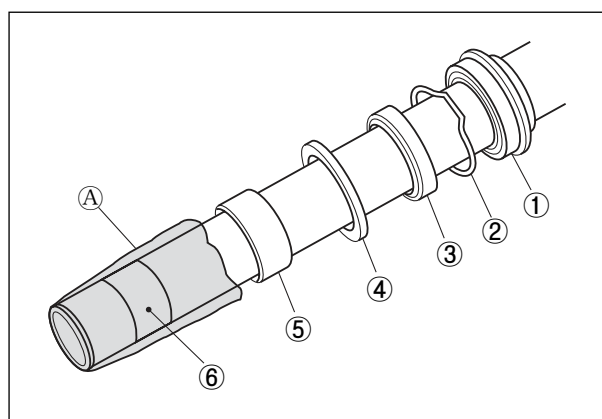

6-23 CHASSIS

- With the oil lock piece fitted to the inner tube, assemble the inner tube to the outer tube.

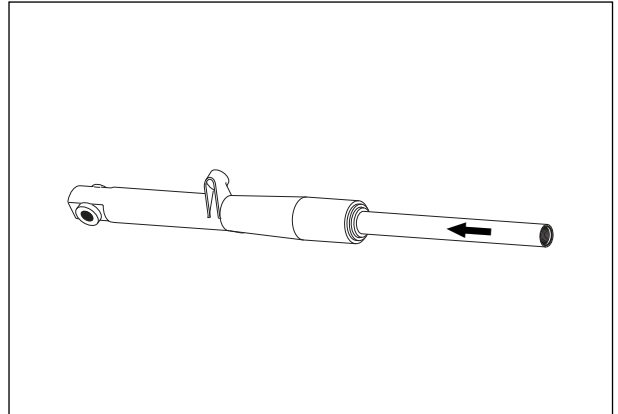

- Apply SUPER GREASE "A" to the lip of the oil seal (A) and install it into the outer tube using the front fork oil seal installer.

 **SUPER GREASE "A"**

 **Front fork oil seal installer set : 09940-52861**

 **CAUTION**

Wash and clean the front fork oil seal installer before using. If dirt is on the installer, the inner tube may possibly be damaged during press-fitting work.

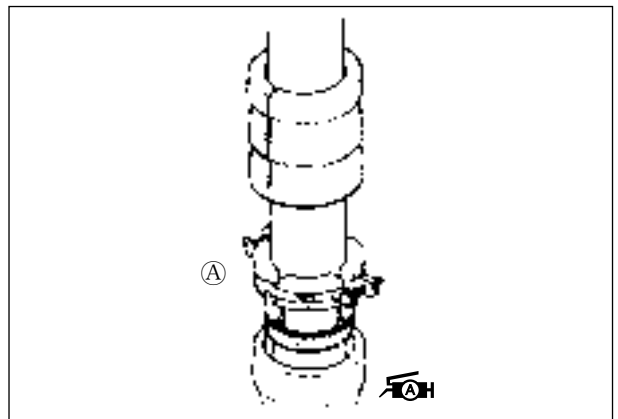

- Fit the stopper ring (2) and dust seal (1).

 **CAUTION**

Make sure that the stopper ring is securely fitted into the groove on the outer tube.

- ① Dust seal
- ② Oil seal stopper ring
- ③ Oil seal
- ④ Oil seal retainer
- ⑤ Slide metal

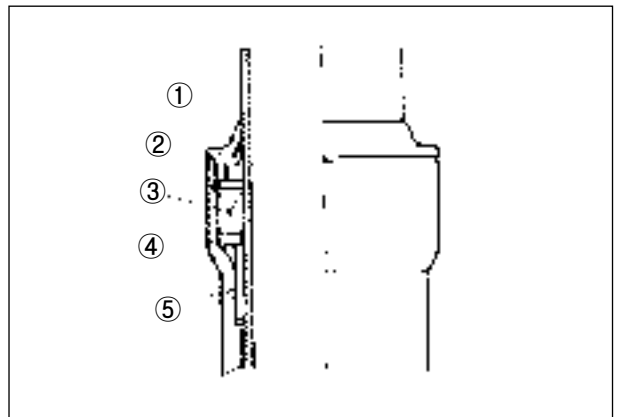

- Fit the rebound spring (7) on the damper rod (6) and install them together to the inner tube.

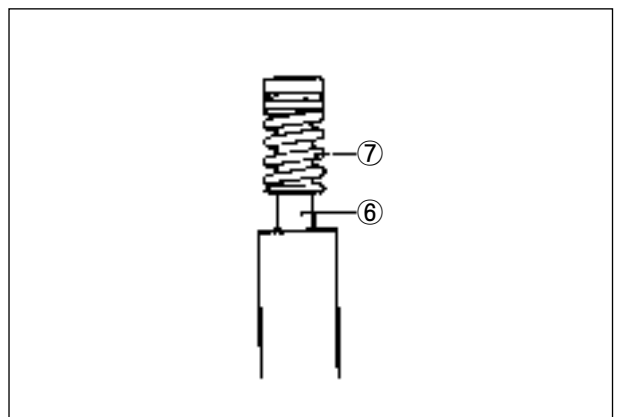

- Apply THREAD LOCK “1324” to the damper rod bolt ②.
- With the damper rod held immovable, with the gasket ---fitted, tighten the damper rod bolt ②.

Front fork damper rod bolt
: 15~25 N · m (1.5~2.5 kg · m)

THREAD LOCK “1324”

CAUTION

Replace the gasket with a new one.

FRONT FORK OIL

- With the inner tube in fully compressed position, pour the specified amount of fork oil and stroke the tube several times to expel air.

Front fork oil specification : TELLUS #22

Front fork oil capacity	Each leg
	250 cc

- With the front fork held in vertical position, compress the inner tube all the way.

- Wait until the fluid level stabilizes, measure and adjust the level to specification using the special tool.

Front fork oil level	325 mm (without spring)
-----------------------------	----------------------------

Front fork oil level gauge : 09943-74111

- Install the front fork spring ③.
- Install the spring guide ④, front fork inner spacer ⑤, and O-ring ⑥.

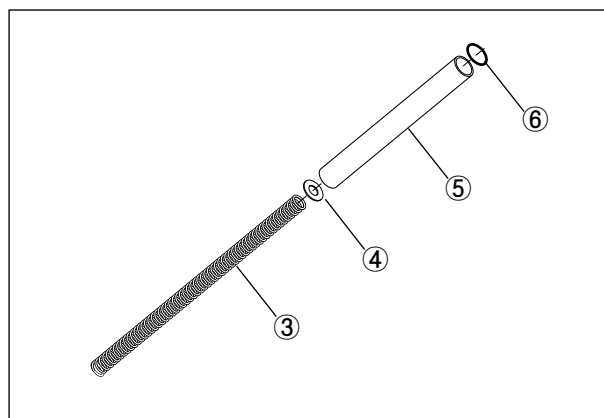
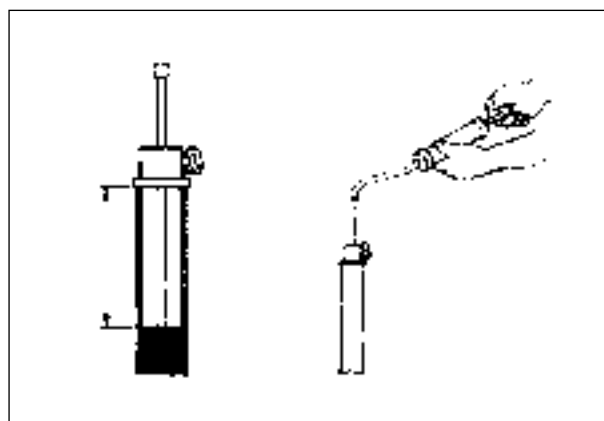
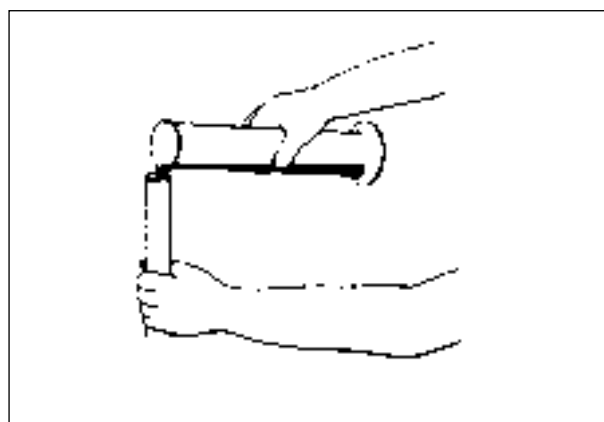
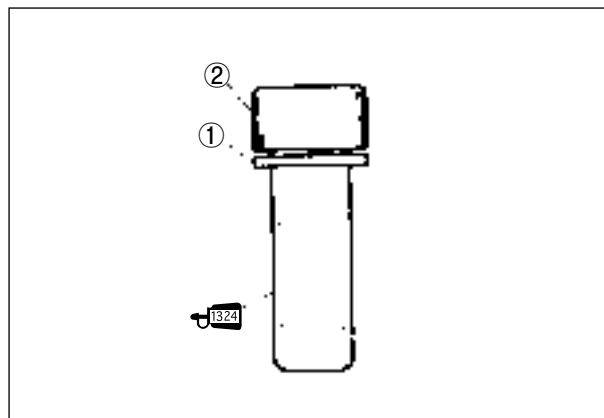

6-25 CHASSIS

- Fit the O-ring to the front fork upper bolt and apply SUPER GREASE "A".

 **SUPER GREASE "A"**

CAUTION

Use a new O-ring to prevent oil leakage.

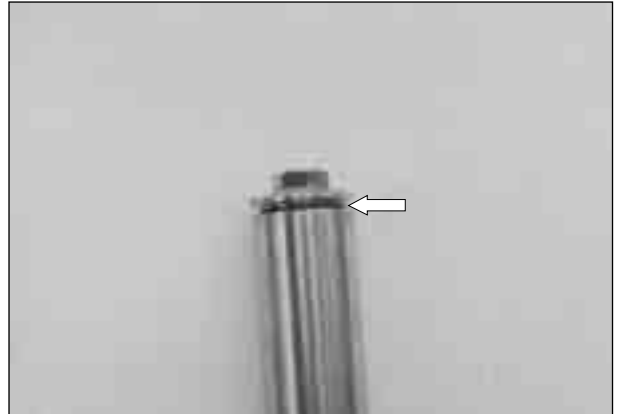

- Install the front fork to the motorcycle.
- Align the upper surface of the inner tube with the upper surface of the steering stem upper bracket.



- Tighten the front fork lower clamp bolts ① and front fork upper bolts ② to the specified torque.
- Tighten the front fork upper clamp bolts ③ to the specified torque.

- **Front fork upper clamp bolt**
: 22~35 N · m (2.2~3.5 kg · m)
- **Front fork lower clamp bolt**
: 22~35 N · m (2.2~3.5 kg · m)
- **Front fork upper bolt**
: 15~30 N · m (1.5~3.0 kg · m)



- Install the front fender and tighten the mounting bolts temporarily.
- Install the front wheel. (Refer to page 6-8)
- Install the front brake caliper. (Refer to page 6-12)
- Move the front fork up and down several times.
- Tighten the front fender mounting bolts securely.

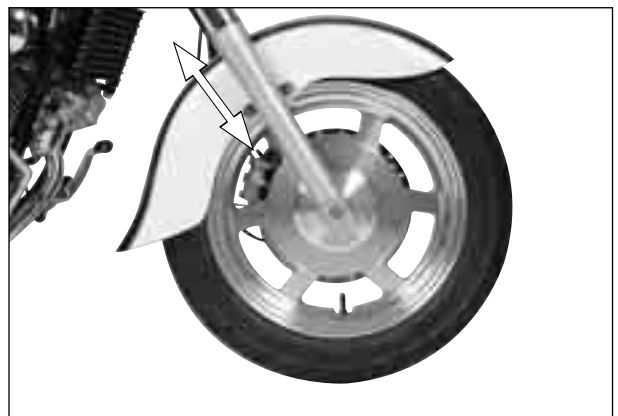

STEERING

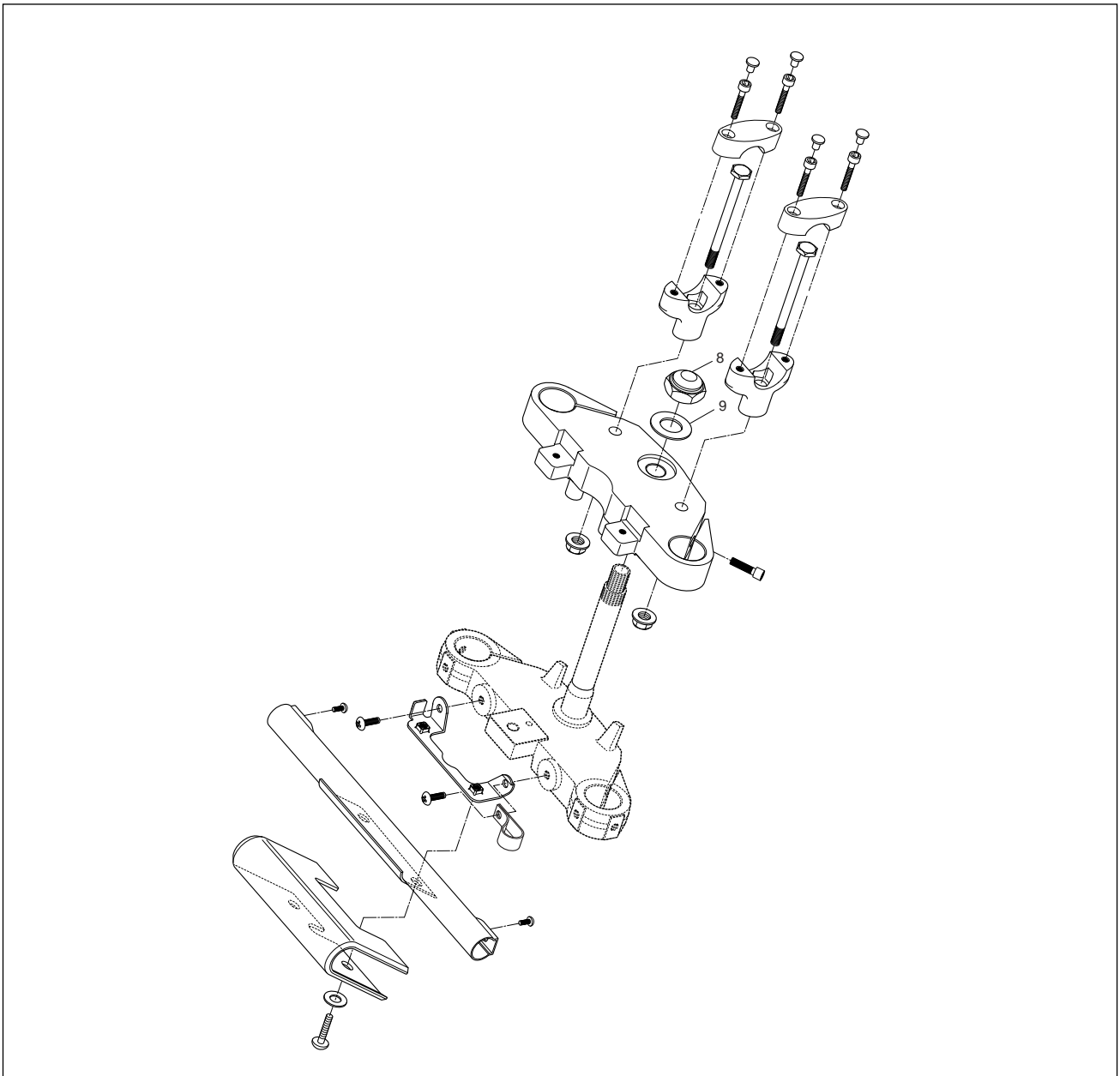

● DISASSEMBLY

- Remove the front wheel. (Refer to page 6-6)
- Remove the front fork. (Refer to page 6-19)
- Remove the cable guide.



6-27 CHASSIS

- With the nuts removed, remove the headlamp housing.
- Remove the handlebars. (Refer to page 6-17)

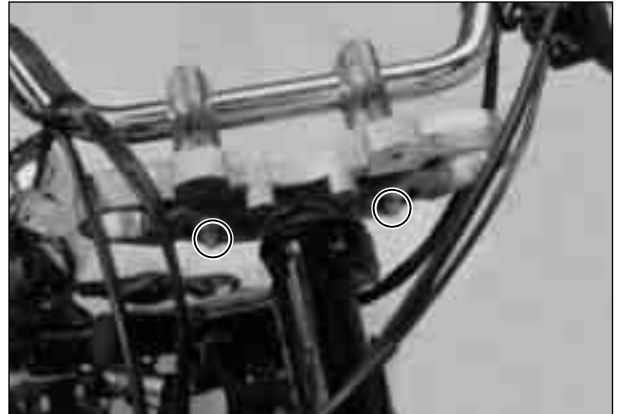

- Remove the steering stem head nut ①.
- Remove the steering stem upper bracket.

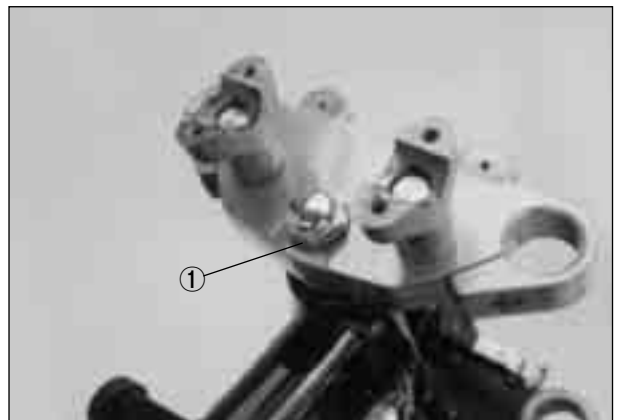

- Remove the steering stem nut ② using the special tool.

 **Clamp wrench : 09940-10122**

- Draw out the steering stem lower bracket.

NOTE:

Hold the steering stem lower bracket to prevent it from falling.

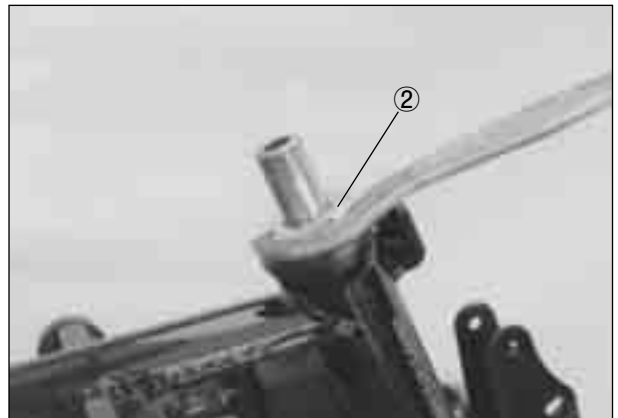

- Remove the handlebar holders by removing the nuts.



- To remove the lower inner race, use a chisel like.

⚠ CAUTION

- ❖ Unless corrosion, damage or other abnormal condition is found, the bearing race need not be replaced.
- ❖ Once the lower inner race has been removed, replace it with a new one.

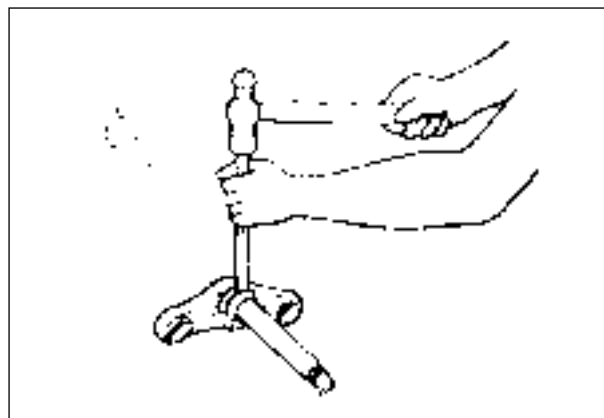

- Drive out the steering stem bearing outer races using the special tools ① and a suitable wedge bar ②.

TOOL Bearing outer race remover ① : 09941-54911

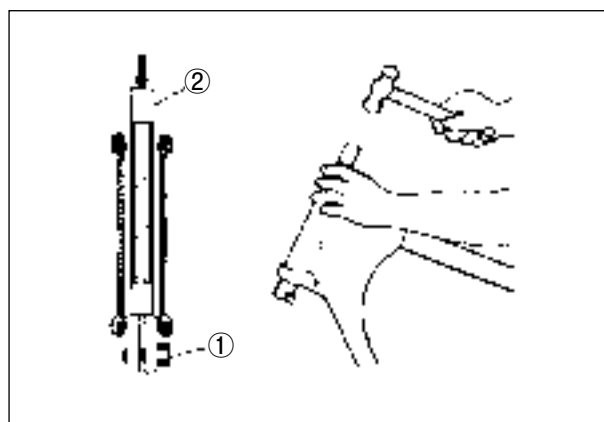

⊙ INSPECTION

Check the steering stem and steering stem head for any damage.

Check the bearing and race for corrosion, nick or other damage.



⊙ REASSEMBLY

Reassembly can be performed in reverse order of disassembly procedures.

However, operate the work taking care for the following points.

- Press in the upper and lower outer race using the special tool.

TOOL Steering race installer : 09941-34513

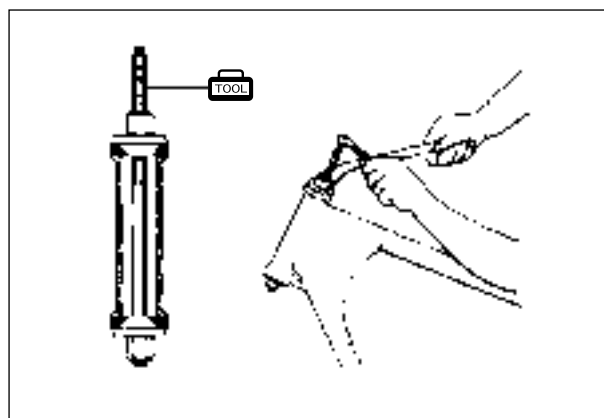

6-29 CHASSIS

- Press in the lower inner race ①.

 **Bearing installer : 09913-80112**

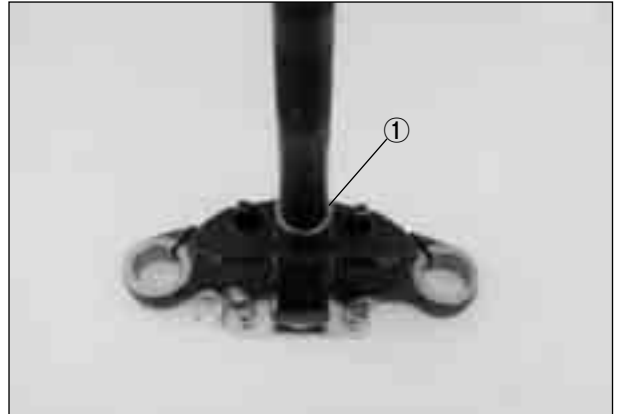

- Apply SUPER GREASE "A" to the upper bearing, lower bearing and outer races prior to installing the steering stem.

 **SUPER GREASE A**

- Install the upper inner race ② and dust cover ③.

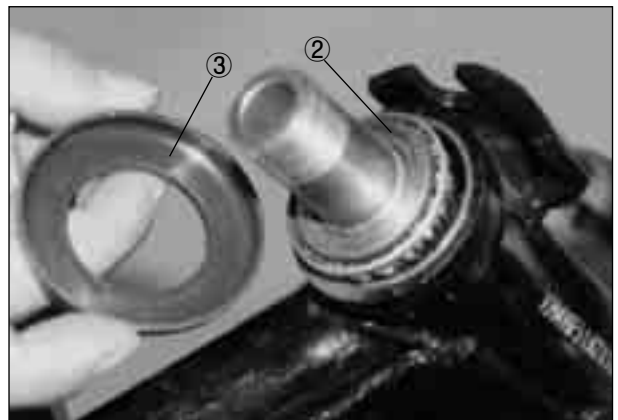

- Install the handlebar holders and tighten their nuts temporarily.



- Install the steering stem.
- Tighten the steering stem nut.

 **Steering stem nut : 40~50 N · m (4.0~5.0 kg · m)**

 **Clamp wrench : 09940-10122**



- Turn the steering stem lower bracket about five or six times to the left and right.
- Loosen the steering stem nut $\frac{1}{4}$ - $\frac{1}{2}$ of a turn (A).

NOTE:

This adjustment will vary from motorcycle to motorcycle. Make sure that the steering turns smoothly and easily in both directions without play.

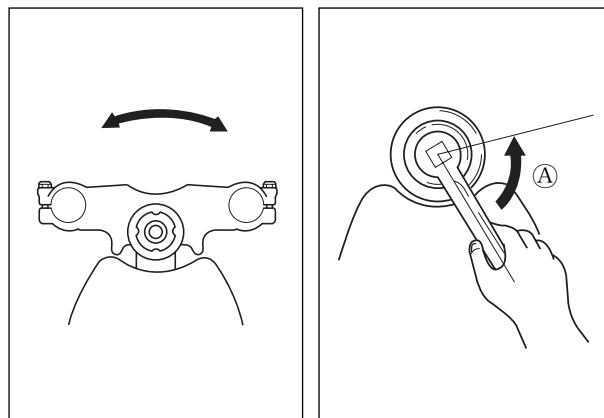

- Install the steering stem upper bracket (1) and washer (2).
- Tighten the steering stem head nut temporarily.

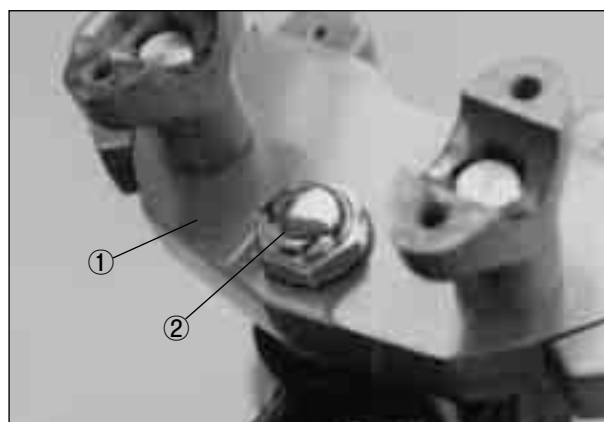

- Install the handlebars. (Refer to page 6-17)
- Tighten the handlebar holder nuts to the specified torque.

🔩 Handlebar holder lower nut
: 40~60 N · m (4.0~6.0 kg · m)

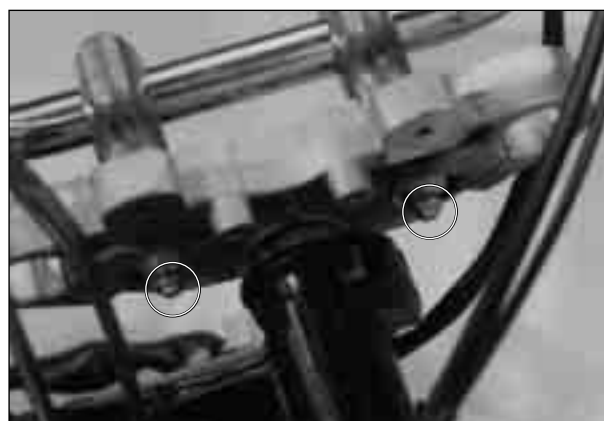

- Align the upper surface of the front fork inner tube with the upper surface of the steering stem upper bracket.
- Tighten the upper front fork clamp bolts to the specified torque.

🔩 Front fork upper clamp bolt
: 22~35 N · m (2.2~3.5 kg · m)

- Tighten the steering stem head nut to the specified torque.

🔩 Steering stem head nut
: 80~100 N · m (8.0~10.0 kg · m)



6-31 CHASSIS

- Install the cable guide.
- Install the front wheel. (Refer to page 6-8)



NOTE:
Hold the front fork legs, move them back and forth and make sure that the steering is not loose.



REAR WHEEL

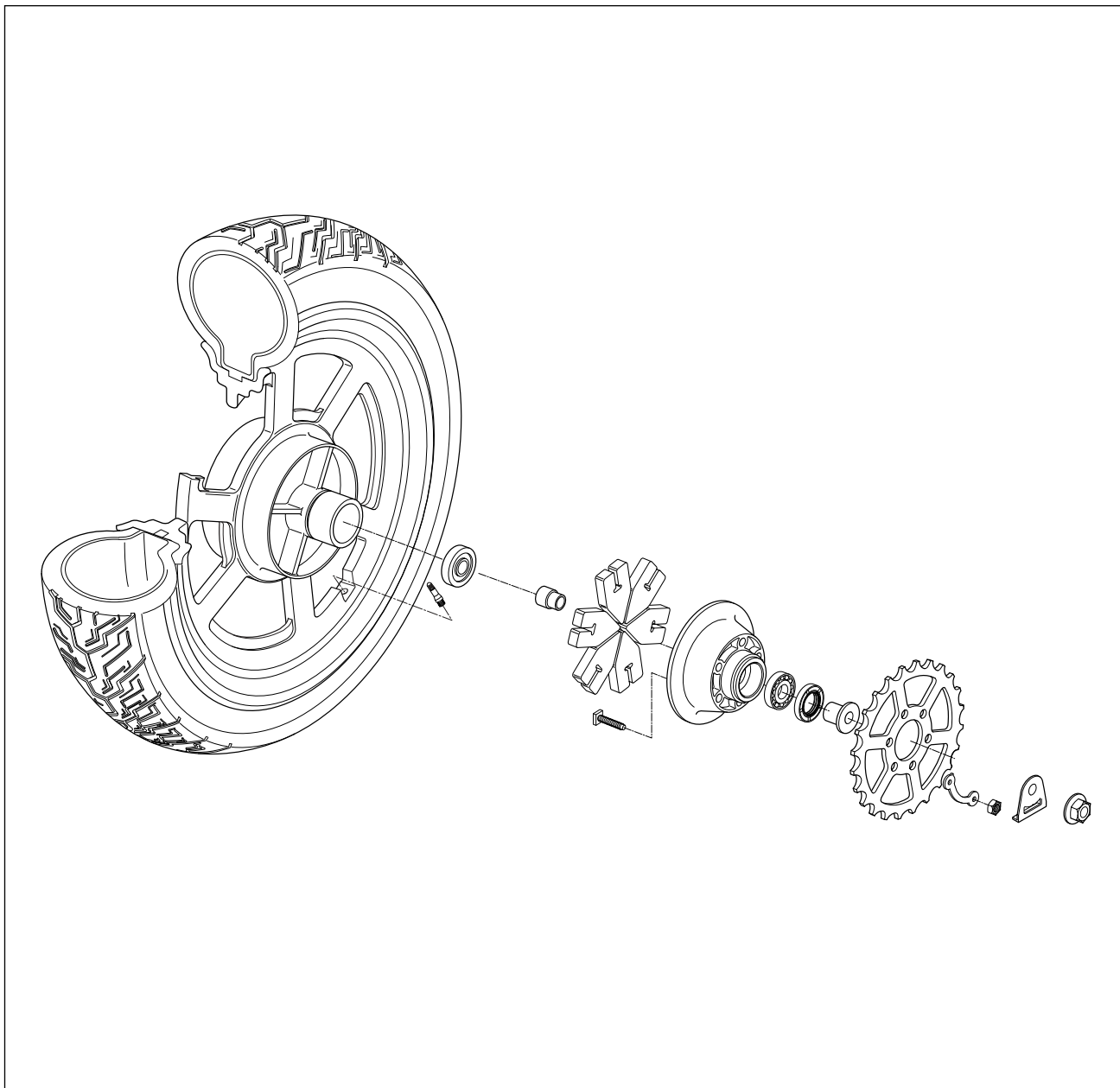

REMOVAL

- Remove the drive chain cover.



6-33 CHASSIS

- Remove the rear brake adjusting nut ①, spring ② and washer ③.

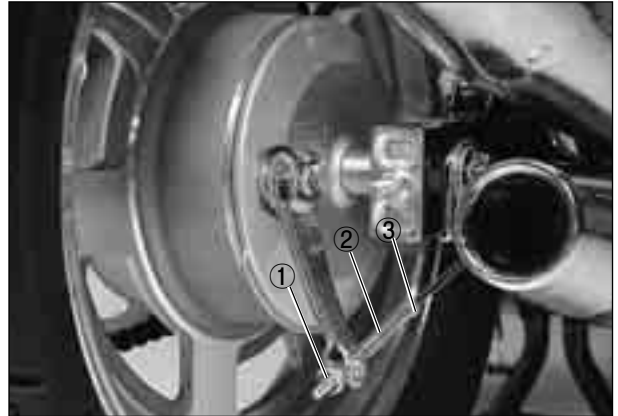

- Raise the rear wheel off the ground with a jack or block.
- Loosen the drive chain adjuster ④, right and left.
- Disengage the drive chain from the rear sprocket.

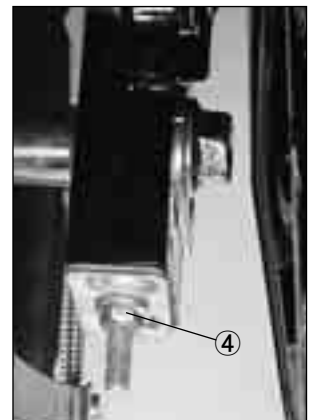
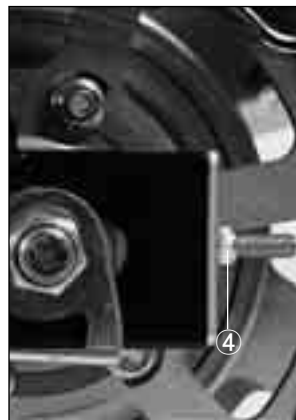

- Loosen the rear shock absorber upper bolt ⑤, right and left.





- Draw out the rear axle ⑥ with the rear wheel push to the bottom.
- Pull the rear wheel assembly rearward.



- Remove the rear brake panel .
(Refer to page 6-39)



- Remove the spacer .
- Remove the rear sprocket  with mounting drum from the rear wheel.

NOTE:
Before separating the rear sprocket and mounting drum, slightly loosen the rear sprocket bolts.

- Remove the rear wheel shock absorber .

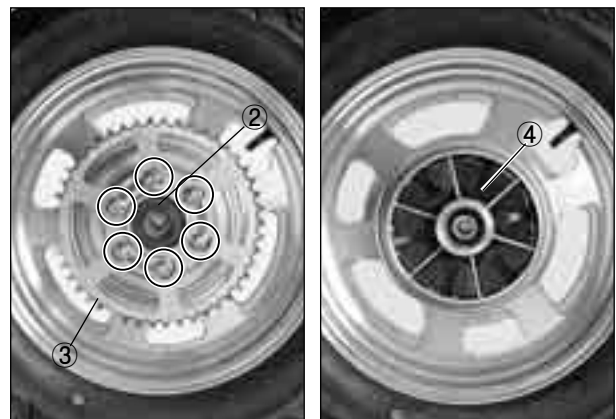

- Remove the rear sprocket  from the rear sprocket mounting drum.

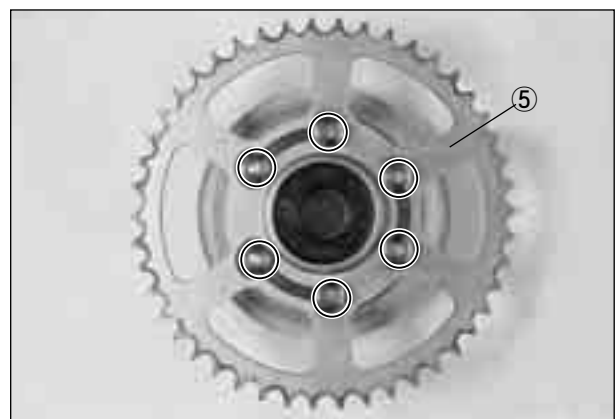

- Remove the dust seal.

 Oil seal remover : 09913-50121



● **INSPECTION**

WHEEL AXLE : Refer to page 6-7

WHEEL : Refer to page 6-7

WHEEL BEARING : Refer to page 6-7

REAR SPROCKET MOUNTING DRUM BEARING : Refer to page 6-7

BRAKE DRUM : Refer to page 6-40

■ **REAR WHEEL SHOCK ABSORBER**

Inspect the rear wheel shock absorber for wear and damage. Replace the rear wheel shock absorber if there is anything unusual.



■ **SPROCKET**

Inspect the sprocket's teeth for wear. If they are worn, replace the sprocket and drive chain as a set.

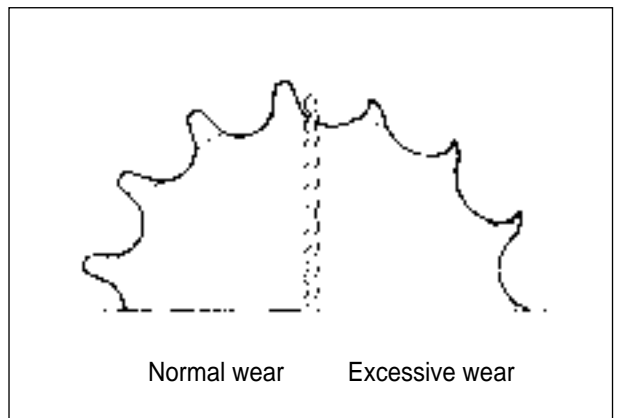

■ **WHEEL BEARING REMOVAL**

● Remove the bearing by using the special tool.

 Wheel bearing remover : 09941-50111

 **CAUTION**

The removed bearing should be replaced with new one.

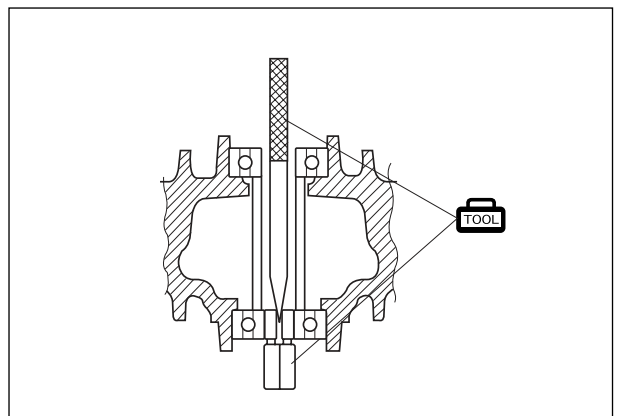

■ REAR SPROCKET MOUNTING DRUM BEARING

- Remove the bearing by using special tool.

 Bearing remover(17mm) : 09923-73210

CAUTION

The removed bearing should be replaced with new one.



⊙ REASSEMBLY

Reassemble the rear wheel and rear brake in the reverse order of disassembly.

Pay attention to the following points :

■ WHEEL BEARING

- Apply SUPER GREASE "A" to the bearing before installation.

 SUPER GREASE "A"

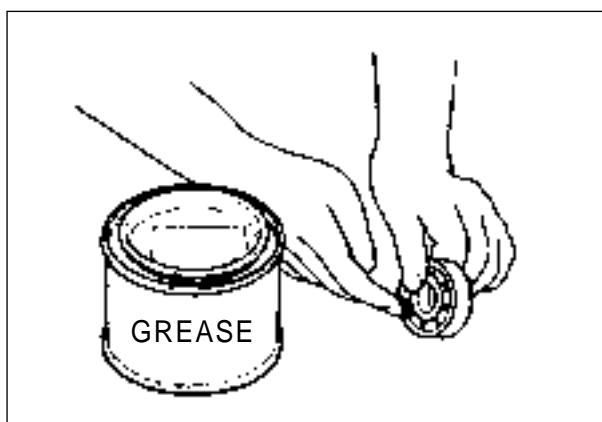

- Press fit the bearing to the wheel using the special tools.

 Steering race installer : 09941-34513

CAUTION

First install the right wheel bearing, then left wheel bearing.



■ REAR SPROCKET MOUNTING DRUM BEARING

- Install the rear sprocket mounting drum bearing and dust seal using the special tool.

 Steering race installer : 09941-34513

NOTE:

Apply grease to the bearing and dust seal lip before assembling the rear sprocket mounting drum.

 SUPER GREASE "A"



■ REAR SPROCKET

● Tighten the rear sprocket nuts to the specified torque.

🔧 Rear sprocket nut : 22~35 N · m (2.2~3.5 kg · m)

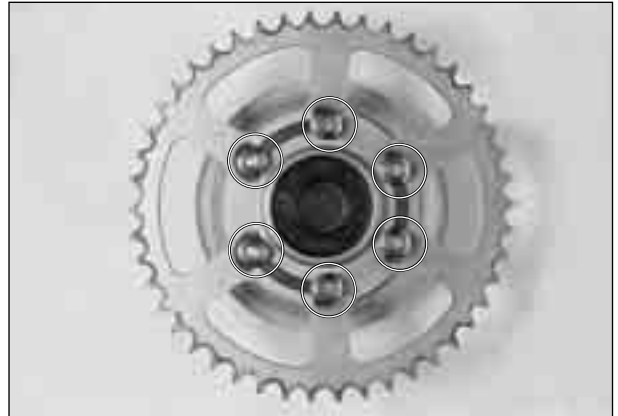

● Install the retainer to the mounting drum as shown.



■ REAR WHEEL

● After the rear wheel install, tighten the rear axle nut ① to the specified torque.

🔧 Rear axle nut : 90~140 N · m (9.0~14.0 kg · m)



● Tighten the rear shock absorber upper bolt ②, right and left

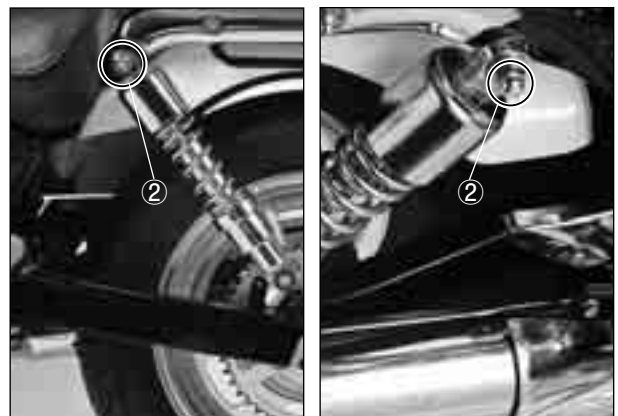

- After installing the drive chain to the rear sprocket, adjust the drive chain.
- Tighten both chain adjusting nuts securely.
- Adjust the rear brake pedal free travel. (Refer to page 2-17)

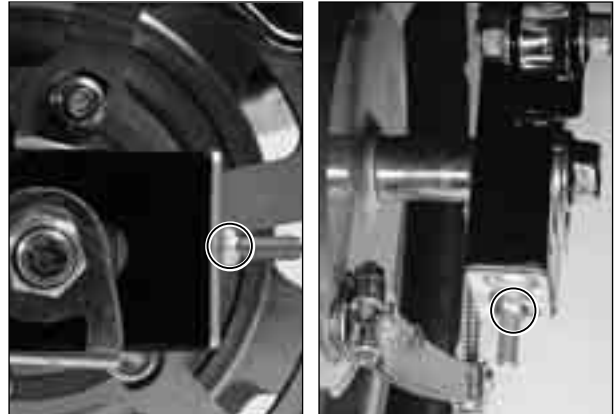

REAR BRAKE

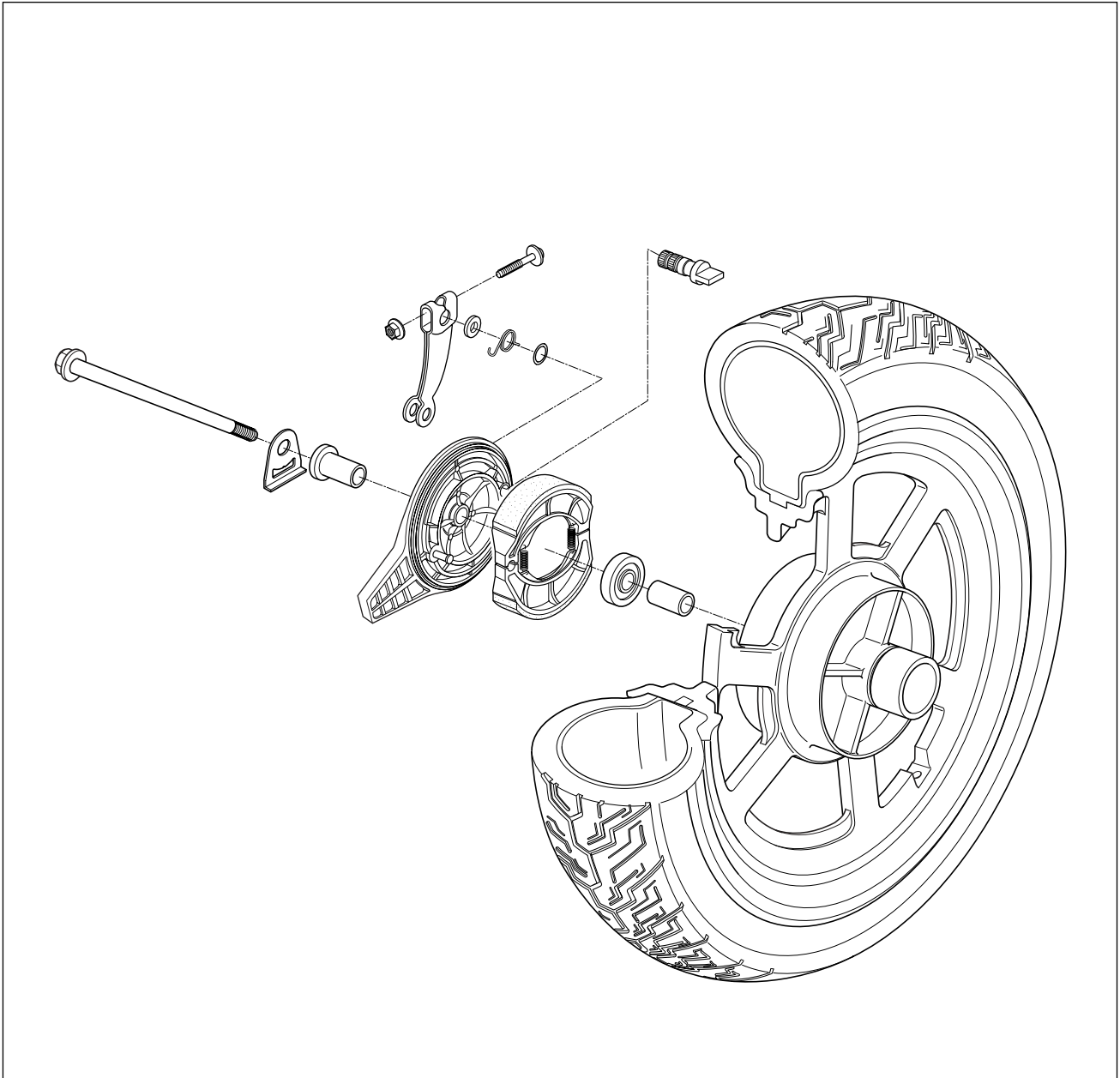

⦿ **DISASSEMBLY**

- Remove the rear wheel. (Refer to page 6-32)
- Remove the brake panel.



- Remove the brake shoes.



- Remove the rear brake cam lever ① and rear brake cam ② by removing nut.

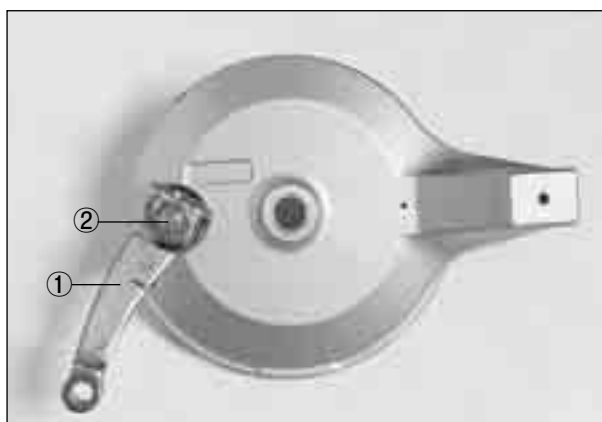

- Remove the washer ③ and O-ring ④.

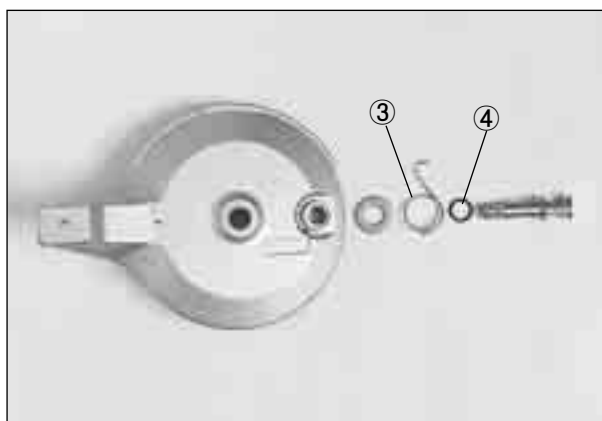

⦿ **INSPECTION**

■ **BRAKE DRUM**

Inspect the brake drum and measure the brake drum I.D. to determine the extent of wear. Replace the brake drum if the measurement exceeds the service limit. The value of this limit is indicated inside the brake drum.

Brake drum I.D.	Service limit
	160.7 mm

 Vernier calipers : 09900-20101



■ BRAKE SHOES

Check the brake shoe wear (Refer to page 2-17) and decide whether it should be replaced or not.

⚠ CAUTION

Replace the brake shoes as a set, otherwise braking performance will be adversely affected.

⊙ REASSEMBLY

■ BRAKE CAMSHAFT

● When installing the brake camshaft, apply SUPER GREASE "A" to the camshaft and cam face.

 SUPER GREASE "A"

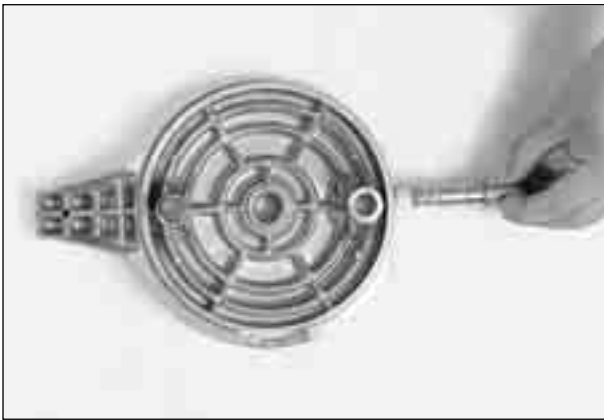

● Install the brake shoes with spring hooks faced inside.

⚠ CAUTION

Be careful not to apply too much grease to the cam and pin. If grease gets on the lining, brake slippage will result.



■ BRAKE CAM LEVER

● Install the new O-ring and washer.
● Install the brake cam lever to the brake camshaft as shown.

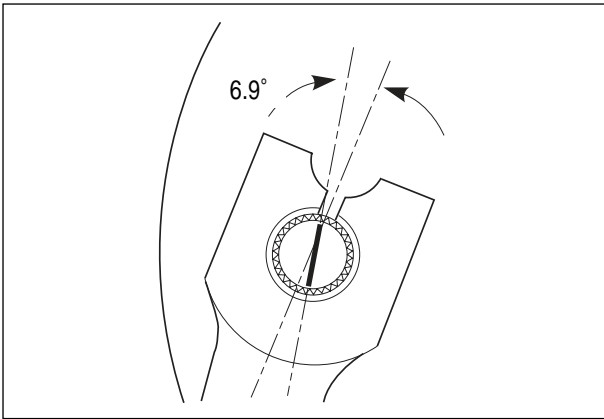

- Tighten the brake cam lever nut to the specified torque.

 Rear brake cam lever nut : 8~12 N · m (0.8~1.2 kg · m)



- Install the rear wheel. (Refer to page 6-36)
- Adjust the rear brake pedal free travel. (Refer to page 2-17)

REAR SHOCK ABSORBER

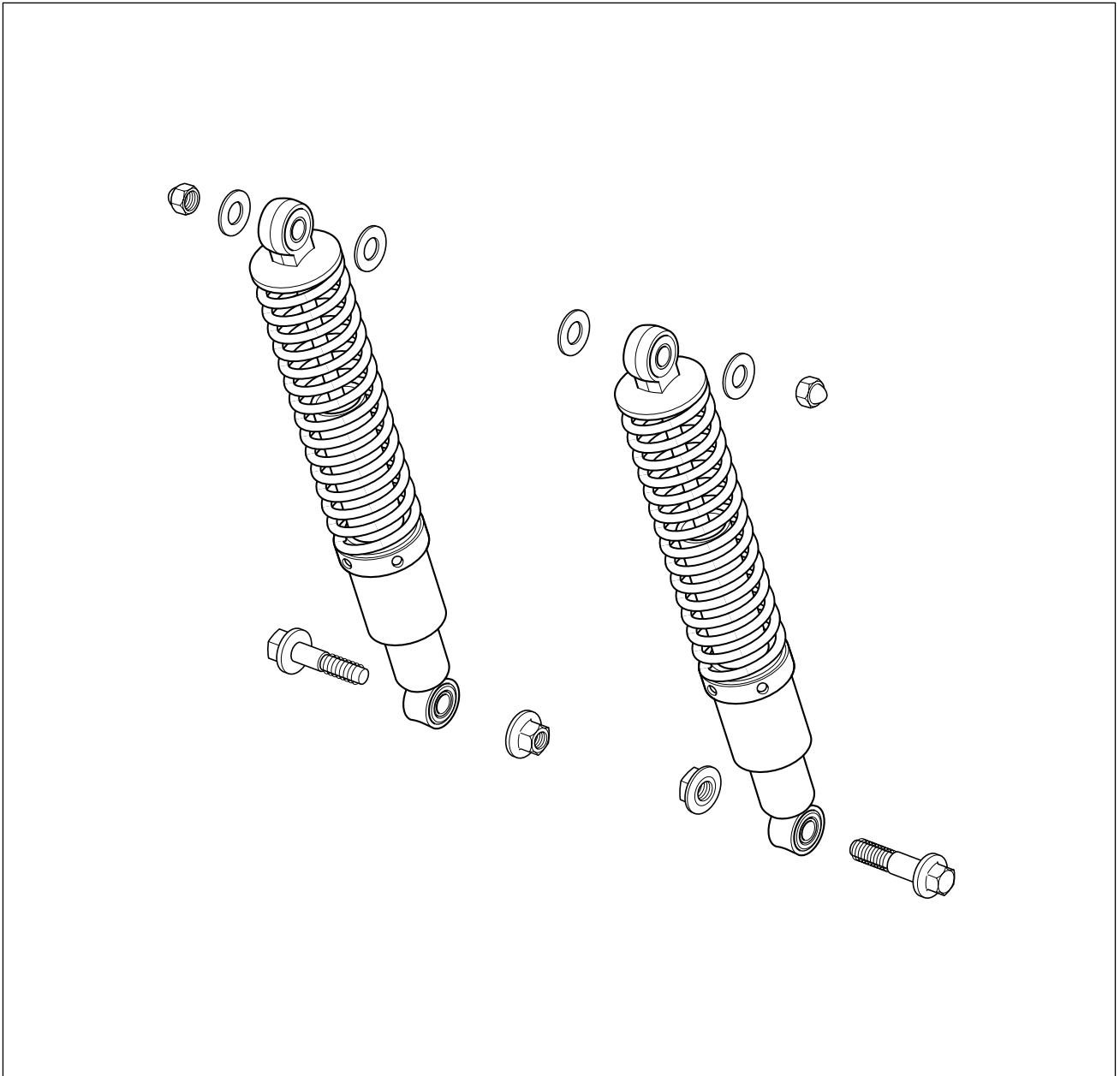

● REMOVAL

- Remove the right and left rear frame cover. (Refer to page 6-2)
- Remove the right and left rear shock absorbers by removing their nuts.

⦿ **INSPECTION**

Inspect the rear shock absorber for damage and oil leakage. If any defects are found, replace the rear shock absorber with a new one.

⚠ CAUTION

Do not attempt to disassemble the rear shock absorber. It is unserviceable.

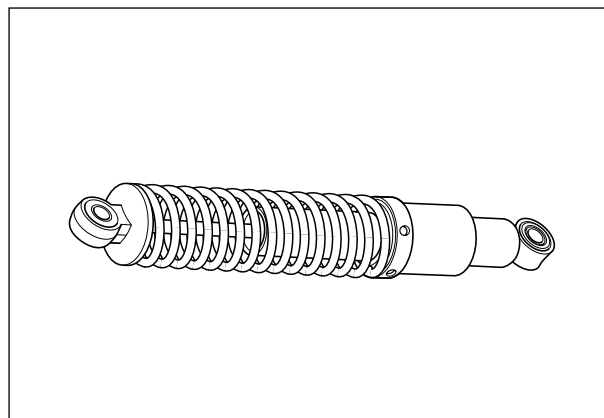

⦿ **REMountING**

● Install the rear shock absorber and tighten the nuts to the specified torque.

- 🔩 Shock absorber mounting nut (upper)
: 20~30 N · m (2.0~3.0 kg · m)
- Shock absorber mounting nut (lower)
: 35~55 N · m (3.5~5.5 kg · m)



⦿ **SPRING PRE-LOAD ADJUSTMENT**

● Adjust the rear shock absorber spring pre-load.

Rear shock absorber	Standard
spring length	199.8 mm

Rear shock absorber	Standard
spring pre-load	1/5 position

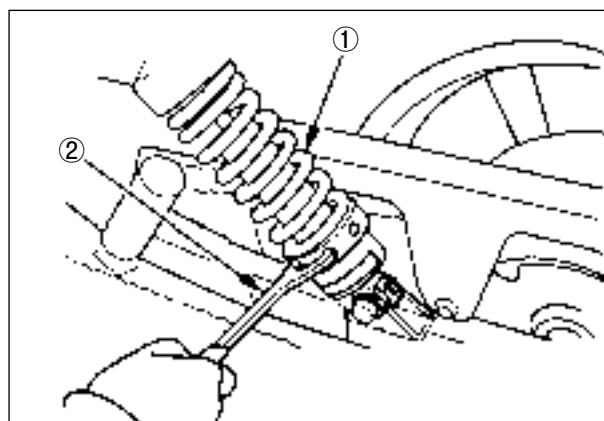

① Rear shock absorber ② Pin spanner

SWINGARM

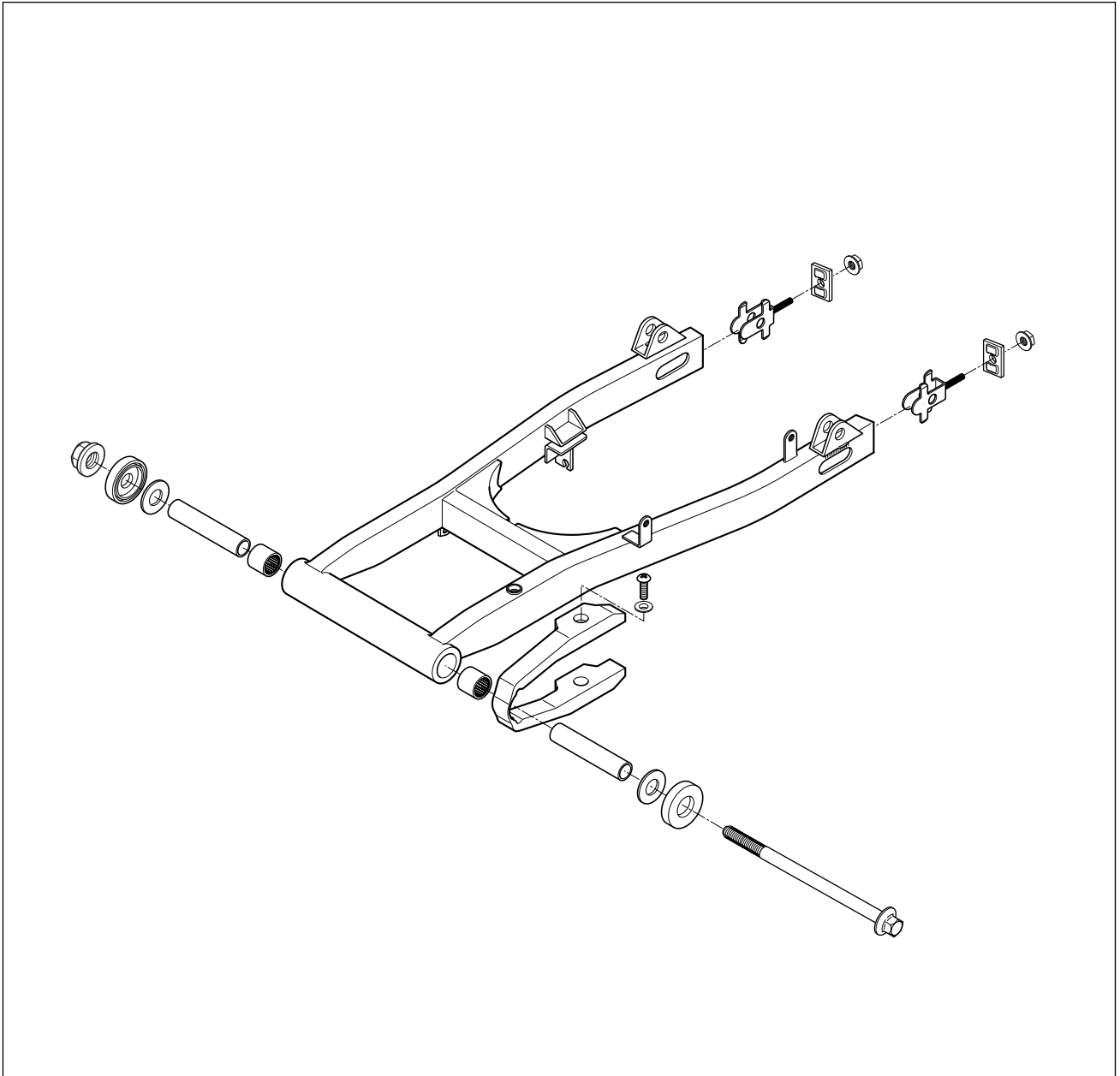

● REMOVAL

- Remove the rear wheel. (Refer to page 6-32)
- Remove the exhaust pipe and mufflers. (Refer to page 3-2)

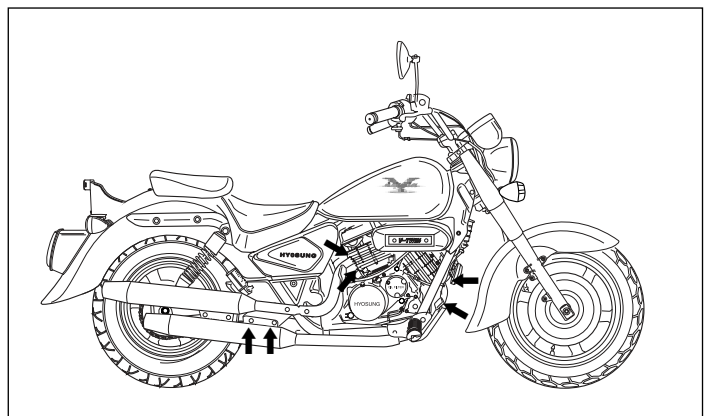

- Remove the engine sprocket cover.

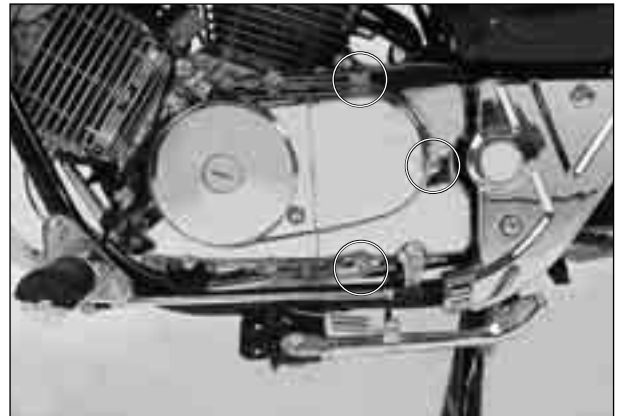

- Remove the swingarm pivot nut and washer.
- Remove the swingarm by removing the pivot shaft.

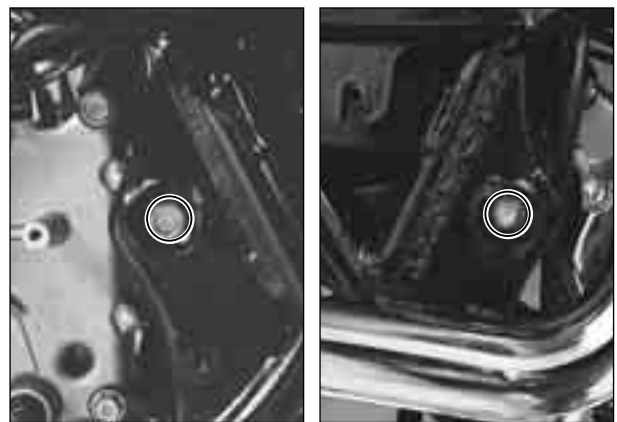

- Remove the rear brake hub from the swingarm.

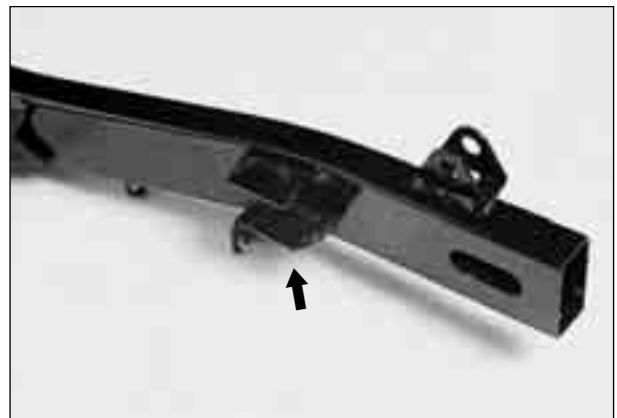

- Remove the dust covers ①, washers ② and spacers ③.

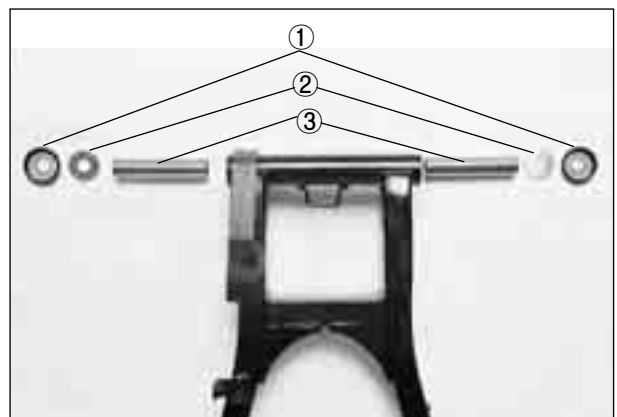

- Remove the chain buffer ① from the swingarm.

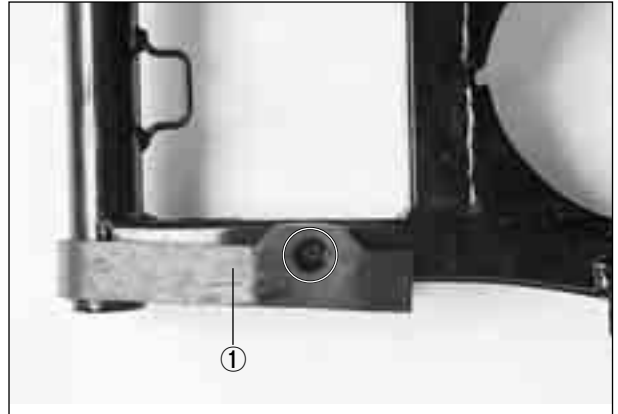

⊙ **INSPECTION**

■ **SWINGARM**

Inspect the swingarm for damage. If any defects are found, replace the swingarm with a new one.

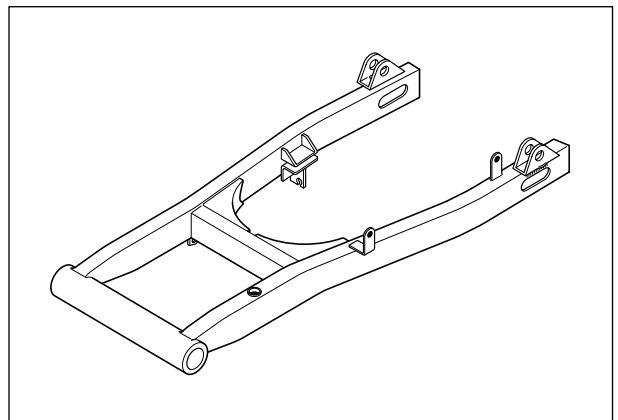

■ **CHAIN BUFFER**

Inspect the chain buffer for wear and damage. If any defects are found, replace the chain buffer with a new one.



■ **SWINGARM PIVOT SHAFT**

Measure the pivot shaft runout using the dial gauge. If the pivot shaft exceeds the service limit, replace it with a new one.

Swingarm pivot shaft runout	Service limit
	0.6 mm

-  Dial gauge : 09900-20606
- Magnetic stand : 09900-20701
- V-block : 09900-21304

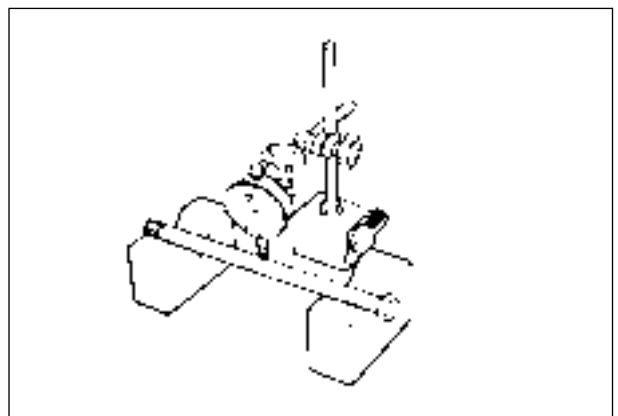

■ SWINGARM PIVOT SPACERS AND DUST SEALS

Inspect the swingarm pivot spacers and dust seals for damage. If any defects are found, replace the spacer with a new one.

■ SWINGARM NEEDLE BEARINGS

Insert the spacers into the needle bearings, rotate the spacer and check for abnormal noise and smooth rotation.

If there is anything unusual, replace the bearing(-s) with a new one.

- Remove the swingarm needle bearings using the special tool.

 **Bearing remover(φ17mm) : 09923-73210**

CAUTION

The removed bearings should be replaced with new ones.

⊙ REASSEMBLY

Reassemble the swingarm and rear shock absorber in the reverse order of disassembly.

Pay attention to the following points :

- Press the needle bearings into the swingarm pivot using the special tool.

 **Steering race installer : 09941-34513**

- Apply SUPER GREASE "A" to the needle bearing and spacers.

 **SUPER GREASE "A"**

- Install the swingarm and tighten the swingarm pivot nut to the specified torque.

 **Swingarm pivot nut : 45~70 N · m (4.5~7.0 kg · m)**

- Install the rear shock absorber. (Refer to page 6-44)
- Install the rear wheel. (Refer to page 6-37)
- Adjust the following points :
 - Drive chain slack : Refer to page 2-13
 - Rear brake pedal free travel : Refer to page 2-17



SERVICING INFORMATION

CONTENTS

TROUBLESHOOTING	7- 1
SPECIAL TOOLS	7- 8
TIGHTENING TORQUE	7-11
SERVICE DATA	7-13
WIRE AND CABLE ROUTING	7-20
WIRING DIAGRAM	7-24

TROUBLESHOOTING

ENGINE

Complaint	Symptom and possible causes	Remedy
<p>Engine will not start, or is hard to start.</p>	<p>Compression too low</p> <ol style="list-style-type: none"> 1. Valve clearance out of adjustment. 2. Worn valve guides or poor seating of valves. 3. Valves mistiming 4. Piston rings excessively worn. 5. Worn-down cylinder bore. 6. Poor seating of spark plug. 7. Starter motor cranks but too slowly. <p>Plug not sparking</p> <ol style="list-style-type: none"> 1. Fouled spark plug. 2. Wet spark plug. 3. Defective ignition coil. 4. Open or short circuit in high tension cord. <p>No fuel reaching the carburetor</p> <ol style="list-style-type: none"> 1. Clogged hole in the fuel tank cap. 2. Clogged or defective fuel cock. 3. Defective carburetor float valve. 4. Clogged fuel pipe. 	<p>Adjust. Repair or replace. Adjust. Replace. Replace or rebore. Retighten. Consult "electrical complaints"</p> <p>Clean or replace. Clean and dry. Replace. Replace..</p> <p>Clean. Clean or replace. Replace. Clean or replace.</p>
<p>Engine stalls easily.</p>	<ol style="list-style-type: none"> 1. Fouled spark plug. 2. Clogged fuel hose. 3. Clogged jets in carburetor. 4. Valve clearance out of adjustment. 	<p>Clean. Clean. Clean. Adjust.</p>
<p>Noisy engine.</p>	<p>Excessive valve chatter</p> <ol style="list-style-type: none"> 1. Valve clearance too large. 2. Weakened or broken valve springs. 3. Worn down camshaft. <p>Noise appears to come from piston</p> <ol style="list-style-type: none"> 1. Piston or cylinder worn down. 2. Weakened or broken valve springs. 3. Worn down piston pin or piston pin bore. 4. Piston rings or ring groove worn. <p>Noise seems to come from timing chain</p> <ol style="list-style-type: none"> 1. Stretched chain. 2. Worn sprockets. 3. Tension adjuster not working. <p>Noise seems to come from clutch</p> <ol style="list-style-type: none"> 1. Worn splines of countershaft or hub. 2. Worn teeth of cluth plates. 3. Distorted clutch plates, driven and drive. <p>Noise seems to come from crankshaft</p> <ol style="list-style-type: none"> 1. Worn or broken bearings. 2. Big-end bearings worn and broken. 3. Thrust clearance too large. 	<p>Adjust. Replace. Replace.</p> <p>Replace. Replace. Replace. Replace.</p> <p>Replace. Replace. Repair or replace.</p> <p>Replace. Replace. Replace.</p> <p>Replace. Replace. Replace.</p>

7-3 SERVICING INFORMATION

Complaint	Symptom and possible causes	Remedy
Engine lacks power.	<ol style="list-style-type: none"> 1. Loosen of valve clearance. 2. Weakened valve springs. 3. Valve timing out of adjustment. 4. Worn piston ring or cylinder. 5. Poor seating of valves. 6. Fouled spark plug. 7. Worn camshaft. 8. Spark plug gap incorrect. 9. Clogged jets in carburetor. 10. Float-chamber fuel level out of adjustment. 11. Clogged air cleaner element. 12. Too much enging oil. 13. Defective air intake pipe. 	Adjust. Replace. Adjust. Replace. Repair or replace. Clean or replace. Replace. Adjust or replace. Clean. Adjust. Clean. Drain out excess oil. Retighten or replace.
Engine overheats.	<ol style="list-style-type: none"> 1. Heavy carbon deposit on piston head. 2. Not enough oil in the engine. 3. Defective oil pump or clogged oil circuit. 4. Fuel level too low in float chamber. 5. Air leak from intake pipe. 6. Use of incorrect engine oil. 7. Defective oil cooler. 	Clean. Add oil. Repair or clean. Adjust. Retighten or replace. change. Clean or replace.

CARBURETOR

Complaint	Symptom and possible causes	Remedy
Trouble with starting.	<ol style="list-style-type: none"> 1. Starter jet is clogged. 2. Starter pipe is clogged. 3. Air leaking from a joint between starter body and carburetor. 4. Starter plunger is not operating properly. 	Clean. Clean. Check starter body and carburetor for tightness, adjust and replace gasket. Check and adjust.
Idling or low-speed trouble.	<ol style="list-style-type: none"> 1. Pilot jet, pilot air jet are clogged or loose. 2. Pilot outlet or bypass is clogged. 3. Starter plunger is not fully closed. 	Check and clean. Check and clean. Check and clean.
Medium or high speed trouble.	<ol style="list-style-type: none"> 1. Main jet or main air jet is clogged. 2. Needle jet is clogged. 3. Throttle valve is not operating properly. 4. Filter is clogged. 	Check and clean. Check and clean. Check throttle valve for operation. Check and clean.
Overflow and fuel level fluctuations.	<ol style="list-style-type: none"> 1. Needle valve is worn or damaged. 2. Spring in needle valve is broken. 3. Float is not working properly. 4. Foreign matter has adhered to needle valve. 5. Fuel level is too high or low. 	Replace. Replace. Check and adjust. Clean. Adjust float height.

ELECTRICAL

Complaint	Symptom and possible causes	Remedy
No sparking or poor sparking.	<ol style="list-style-type: none"> 1. Defective ignition coil. 2. Defective spark plug. 3. Defective CDI unit. 	Replace. Replace. Replace.
Spark plug soon become fouled with carbon.	<ol style="list-style-type: none"> 1. Mixture too rich. 2. Idling speed set too high. 3. Incorrect gasoline. 4. Dirty element in air cleaner. 5. Spark plug too cold. 	Adjust carburetor. Adjust carburetor. Change. Clean or replace. Replace by hot type plug.
Spark plug become fouled too soon.	<ol style="list-style-type: none"> 1. Worn piston rings. 2. Pistons or cylinder worn. 3. Excessive clearance of valve stems in valve guides. 4. Worn stem oil seal. 	Replace. Replace. Replace. Replace.
Spark plug electrodes overheat or burn.	<ol style="list-style-type: none"> 1. Spark plug too hot. 2. The engine overheats. 3. Spark plug loose. 4. Mixture too lean. 	Replace by cold type plug. Tune up. Retighten. Adjust carburetor.
Generator charge, but charging rate is below the specification.	<ol style="list-style-type: none"> 1. Lead wires tend to get shorted or open-circuited or loosely connected at terminals. 2. Grounded or open-circuited stator coils of generator. 3. Defective regulator/rectifier. 4. Not enough electrolyte in the battery. 5. Defective cell plates in the battery. 	Repair or retighten. Replace. Replace. Add distilled water between the level lines. Replace the battery.
Generator overcharges.	<ol style="list-style-type: none"> 1. Internal short-circuit in the battery. 2. Resistor element in the regulator/rectifier damaged or defective. 3. Regulator/rectifier poorly grounded. 	Replace the battery. Replace. Clean and tighten ground connection.
Unstable charging.	<ol style="list-style-type: none"> 1. Lead wire insulation frayed due to vibration resulting in intermittent shorting. 2. Generator internally shorted. 3. Defective regulator/rectifier. 	Repair or replace Replace. Replace.
Starter switch is not effective.	<ol style="list-style-type: none"> 1. Battery run down. 2. Defective switch contacts. 3. Brushes not seating properly on commutator in starter motor. 4. Defective starter relay. 	Recharge or replace. Replace. Repair or replace. Replace.

7-5 SERVICING INFORMATION

BATTERY

Complaint	Symptom and possible causes	Remedy
<p>“Sulfation” acidic white powdery substance or spots on surfaces of cell plates.</p>	<ol style="list-style-type: none"> 1. Not enough electrolyte. 2. Battery case is cracked. 3. Battery has been left in a run-down condition for a long time. 4. Contaminated electrolyte. (Foreign matter has entered the battery and become mixed with the electrolyte.) 	<p>Add distilled water, if the battery has not been damaged and “sulfation” has not advanced too far, and recharge.</p> <p>Replace the battery.</p> <p>Replace the battery or recharge.</p> <p>If “sulfation” has not advanced far, try to restore the battery by replacing the electrolyte, recharging it fully with the battery detached from the motorcycle and then adjusting electrolyte specific gravity.</p>
<p>Battery runs down quickly.</p>	<ol style="list-style-type: none"> 1. The charging method is not correct. 2. Cell plates have lost much of their active material as a result of over-charging. 3. A short-circuit condition exists within the battery due to excessive accumulation of sediments caused by the high electrolyte specific gravity. 4. Electrolyte specific gravity is too low. 5. Contaminated electrolyte. 6. Battery is too old. 	<p>Check the generator, regulator /rectifier and circuit connections, and make necessary adjustments to obtain specified charging operation.</p> <p>Replace the battery, and correct the charging system.</p> <p>Replace the battery.</p> <p>Recharge the battery fully and adjust electrolyte specific gravity.</p> <p>Replace the electrolyte, recharge the battery and then adjust specific gravity.</p> <p>Replace the battery.</p>
<p>Reversed battery polarity.</p>	<p>The battery has been connected the wrong way round in the system, so that it is being charged in the reverse direction.</p>	<p>Replace the battery and be sure to connect the battery properly.</p>
<p>Battery “sulfation”</p>	<ol style="list-style-type: none"> 1. Charging rate too low or too high. (When not in use, batteries should be recharged at least once a month to avoid sulfation.) 2. Battery electrolyte excessive or insufficient, or its specific gravity too high or too low. 3. The battery left unused for too long in cold climate. 	<p>Replace the battery.</p> <p>Keep the electrolyte up to the prescribed level, or adjust the specific gravity by consulting the battery maker’s directions.</p> <p>Replace the battery, if badly sulfated.</p>
<p>Battery discharges too rapidly.</p>	<ol style="list-style-type: none"> 1. Dirty container top and sides. 2. Impurities in the electrolyte or electrolyte specific gravity is too high. 	<p>Clean.</p> <p>Change the electrolyte by consulting the battery maker’s directions.</p>

CHASSIS









Complaint	Symptom and possible causes	Remedy
Steering feels too heavy or stiff.	<ol style="list-style-type: none"> 1. Steering stem nut overtightened. 2. Worn bearing or race in steering stem. 3. Distorted steering stem. 4. Not enough pressure in tires. 	Adjust. Replace. Replace. Adjust.
Steering oscillation.	<ol style="list-style-type: none"> 1. Loss of balance between right and left front suspensions. 2. Distorted front fork. 3. Distorted front axle or crooked tire. 	Replace. Repair or replace. Replace.
Wobbling front wheel.	<ol style="list-style-type: none"> 1. Distorted wheel rim. 2. Worn-down wheel bearings. 3. Defective or incorrect tire. 4. Loosen nut on axle. 	Replace. Replace. Replace. Retighten.
Front suspension too soft.	<ol style="list-style-type: none"> 1. Weakened springs. 2. Not enough fork oil. 	Replace. Refill.
Front suspension too stiff.	<ol style="list-style-type: none"> 1. Fork oil too viscous. 2. Too much fork oil. 	Replace. Drain excess oil.
Noisy front suspension.	<ol style="list-style-type: none"> 1. Not enough fork oil. 2. Loosen nuts on suspension. 	Refill. Retighten.
Wobbling rear wheel.	<ol style="list-style-type: none"> 1. Distorted wheel rim. 2. Worn-down rear wheel bearing. 3. Defective or incorrect tire. 4. Loose nut on axle. 5. Worn swing arm bushing or bearing. 6. Loosen nut on the rear shock. 	Replace. Replace. Replace. Retighten. Replace. Retighten.
Rear suspension too soft.	<ol style="list-style-type: none"> 1. Weakened springs. 2. Rear suspension adjuster improperly set. 	Replace. Adjust.
Rear suspension too stiff.	<ol style="list-style-type: none"> 1. Rear suspension adjuster improperly set. 2. Worn swing arm bushing or bearing. 	Adjust. Replace.
Noisy rear suspension.	<ol style="list-style-type: none"> 1. Loosen nuts on suspension. 2. Worn swing arm bushing or bearing. 	Retighten. Replace.









7-7 SERVICING INFORMATION

BRAKES

Complaint	Symptom and possible causes	Remedy
Poor braking (FRONT and REAR)	<ol style="list-style-type: none"> 1. Not enough brake fluid in the reservoir. 2. Air trapped in brake fluid circuit. 3. Pads worn down. 4. Too much play on brake lever or pedal. 5. Shoes worn down. 	Refill to level mark. Bleed air out. Replace. Adjust. Replace.
Insufficient brake power.	<ol style="list-style-type: none"> 1. Leakage of brake fluid from hydraulic system. 2. Worn pads. 3. Oil adhesion of engaging surface of pads. 4. Worn disk. 5. Air in hydraulic system. 	Repair or replace. Replace. Clean disk and pads. Replace. Bleed air.
Brake squeaking.	<ol style="list-style-type: none"> 1. Carbon adhesion on pad surface. 2. Tilted pad. 3. Damaged wheel bearing. 4. Loosen front-wheel axle or rear-wheel axle. 5. Worn pads. 6. Foreign material in brake fluid. 7. Clogged return port of master cylinder. 	Repair surface with sandpaper. Modify pad fitting. Replace. Tighten to specified torque. Replace. Replace brake fluid. Disassemble and clean master cylinder.
Excessive brake lever stroke.	<ol style="list-style-type: none"> 1. Air in hydraulic system. 2. Worn brake lever cam. 3. Insufficient brake fluid. 4. Improper quality of brake fluid. 	Bleed air. Replace brake lever. Replenish fluid to specified level ; bleed air. Replace with correct fluid.
Leakage of brake fluid.	<ol style="list-style-type: none"> 1. Insufficient tightening of connection joints. 2. Cracked hose. 3. Worn piston and/or cup. 	Tighten to specified torque. Replace. Replace piston and/or cup.









SPECIAL TOOLS

Special tools	Part Number · Part Name · Description
	09900-20101 Vernier Caliper Used to conveniently measure various dimensions.
	09900-20201 Micrometer(0~25mm) Used for precise measurement (00-25mm measure ranges).
	09900-20202 Micrometer(25~50mm) Used for precise measurement (25-50mm measure ranges).
	09900-20203 Micrometer(50~75mm) Used for precise measurement (50-75mm measure ranges).
	09900-20508 Cylinder gauge set Measure inside diameter of cylinder.
	09900-20605 Dial calipers Meassure width of conrod big-end.
	09900-20606 Dial gauge Meassure oscillation of wheel with using magnetic stand.
	09900-20701 Magnetic stand With using dial gauge.
	09900-20806 Thickness gauge Measure clearance of piston ring.

Special tools	Part Number · Part Name · Description
	09900-21109 Torque wrench Measure torque of tightening.
	09900-21304 V-block With using magnetic stand.
	09900-22301 Plastigauge Measure clearance of crankshaft thrust.
	09900-22401 Small bore gauge Measure inside diameter of conrod small-end.
	09900-25002 Pocket tester Measure voltage, electric current, resistance.
	09900-26006 Engine tachometer Measure rotational frequency of engine.
	09900-28107 Electro tester Inspect ignition coil.
	09900-28500 Battery charger Used to charge the dischared battery.
	09910-20115 Conrod holder Used to lock the crankshaft.

7-9 SERVICING INFORMATION

Special tools	Part Number · Part Name · Description
	09910-32812 Crankshaft installer Used to install the crankshaft in the crankcase.
	09910-34510 Piston pin puller Use to remove the piston pin.
	09913-10760 Fuel level gauge Measure height of carburetor.
	09913-50121 Oil seal remover Used to remove the oil seal.
	09913-70122 Bearing installer Used to drive bearing in.
	09913-75520 Bearing installer Used to drive bearing in.
	09913-75820 Bearing installer Used to drive bearing in.
	09913-75830 Bearing installer Used to install rear axle shaft oil seal.
	09913-76010 Bearing installer Used to drive crankshaft bearing in.

Special tools	Part Number · Part Name · Description
	09913-80112 Bearing installer Used to drive bearing in.
	09915-63310 Compression gauge adapter Used with compression gauge.
	09915-64510 Compression gauge Measure cylinder compression.
	09915-74510 Oil pressure gauge Measure oil pressure of 4-stroke engine.
	09915-74531 Oil pressure gauge hose attachment Used with oil pressure gauge.
	09916-14510 Valve spring compressor Used to remove and remounting valve stem.
	09916H35C00 Valve spring compressor attachment Used with valve spring compressor.
	09920-13120 Crankcase separator Separate to crankcase.
	09920-53710 Clutch sleeve hub holder Used to install or remove clutch sleeve hub nut.

Special tools	Part Number · Part Name · Description
	09921-20200 Bearing remover(10mm)
	Used to remove oil seal or bearing.
	09921-20210 Bearing remover(12mm)
	Used to remove oil seal or bearing.
	09923-73210 Bearing remover(17mm)
	Used to remove bearing with the rotor remove sliding shaft.
	09923-74510 Bearing remover(20~35mm)
	Used to remove bearing with the rotor remove sliding shaft.
	09924-84521 Bearing installer
	Used to drive small bearing in.
	09930-10121 Spark plug socket wrench set
	Used to remove or remounting spark plug.
	09930-30102 Rotor remove sliding shaft
	Used to with bearing remover or rotor remover.
	09930-30164 Rotor remover
	Attached to the top of sliding shaft when removing rotor.
	09930-40113 Rotor holder
	Widely used to lock rotary parts such as a flywheel magneto.

Special tools	Part Number · Part Name · Description
	09930-44510 Rotor holder
	Widely used to lock rotary parts such as a flywheel magneto.
	09940-10122 Clamp wrench
	A hook wrench to adjust the steering head of motorcycle.
	09940-34520 T-handle
	Remove and remounting front fork oil cylinder.
	09940-34561 Front fork assembling tool attachment "D"
	Used with T-handle.
	09940-50113 Front fork oil seal installer
	Install front fork oil seal.
	09941-34513 Steering race installer
	Used to install steering outer race.
	09941-50111 Wheel bearing remover
	Used to remove wheel bearing.
	09943-74111 Front fork oil level gauge
	Used to drain the fork oil to the specified level.

TIGHTENING TORQUE

ENGINE

ITEM	N · m	kg · m
Magneto rotor nut	50 ~ 60	5.0 ~ 6.0
Magneto cover bolt	8 ~ 12	0.8 ~ 1.2
Muffler mounting bolt	20 ~ 30	2.0 ~ 3.0
Exhaust pipe nut	18 ~ 28	1.8 ~ 2.8
Starter clutch bolt	15 ~ 20	1.5 ~ 2.0
Cylinder head bolt	7 ~ 11	0.7 ~ 1.1
Cylinder head cover bolt	12 ~ 16	1.2 ~ 1.6
Cylinder head stud bolt	21 ~ 25	2.1 ~ 2.5
Cylinder head base nut	7 ~ 11	0.7 ~ 1.1
Engine sprocket nut	80 ~ 100	8.0 ~ 10.0
Engine oil drain plug	18 ~ 20	1.8 ~ 2.0
Engine mounting bolt	40 ~ 60	4.0 ~ 6.0
Cam chain sprocket bolt	10 ~ 13	1.0 ~ 1.3
Cam chain tensioner bolt	6 ~ 8	0.6 ~ 0.8
Cam chain tension adjuster bolt	8 ~ 12	0.8 ~ 1.2
Camshaft sprocket bolt	10 ~ 12	1.0 ~ 1.2
Crankcase bolt	8 ~ 12	0.8 ~ 1.2
Clutch sleeve hub nut	30 ~ 50	3.0 ~ 5.0
Primary drive gear nut	40 ~ 60	4.0 ~ 6.0
Camshaft housing bolt	8 ~ 12	0.8 ~ 1.2
Oil cooler union bolt (M10)	20 ~ 25	2.0 ~ 2.5
Oil cooler union bolt (M12)	20 ~ 25	2.0 ~ 2.5
Spark plug	20 ~ 25	2.0 ~ 2.5
Neutral cam stopper plug	20 ~ 25	2.0 ~ 2.5

CHASSIS

ITEM	N · m	kg · m
Rear brake cam lever bolt	8 ~ 12	0.8 ~ 1.2
Rear shock absorber fitting nut (Upper)	20 ~ 30	2.0 ~ 3.0
Rear shock absorber fitting nut (Lower)	35 ~ 55	3.5 ~ 5.5
Rear sprocket nut	22 ~ 35	2.2 ~ 3.5
Rear axle nut	90 ~ 140	9.0 ~ 14.0
Swing arm pivot nut	45 ~ 70	4.5 ~ 7.0
Steering stem nut	40 ~ 50	4.0 ~ 5.0
Steering stem head nut	80 ~ 100	8.0 ~ 10.0
Front brake disc bolt	18 ~ 28	1.8 ~ 2.8
Front brake master cylinder mounting bolt	5 ~ 8	0.5 ~ 0.8
Front brake caliper air bleeder valve	6 ~ 9	0.6 ~ 0.9
Front brake caliper mounting bolt	18 ~ 28	1.8 ~ 2.8
Front brake hose union bolt	20 ~ 25	2.0 ~ 2.5
Front axle	50 ~ 80	5.0 ~ 8.0
Front axle pinch bolt	15 ~ 25	1.5 ~ 2.5
Front fork damper rod bolt	15 ~ 25	1.5 ~ 2.5
Front fork upper clamp bolt	22 ~ 35	2.2 ~ 3.5
Front fork upper bolt	15 ~ 30	1.5 ~ 3.0
Front fork lower clamp bolt	22 ~ 35	2.2 ~ 3.5
Front footrest bolt	36 ~ 52	3.6 ~ 5.2
Handlebar clamp bolt	18 ~ 28	1.8 ~ 2.8
Handlebar holder lower nut	40 ~ 60	4.0 ~ 6.0

SERVICE DATA

VALVE + GUIDE

Unit : mm

ITEM	STANDARD		LIMIT
Valve diam.	IN.	22	—
	EX.	19.0	—
Valve clearance (When cold)	IN.	0.1~0.2	—
	EX.	0.2~0.3	—
Valve guide to valve stem clearance	IN.	0.010~0.037	—
	EX.	0.030~0.057	—
Valve stem deflection	IN. & EX.	—	0.35
Valve guide I.D.	IN. & EX.	4.500~4.512	—
Valve stem O.D.	IN.	4.475~4.490	—
	EX.	4.455~4.470	—
Valve stem runout	IN. & EX.	—	0.05
Valve head thickness	IN. & EX.	—	0.5
Valve seat width	0.9~1.1		—
Valve seat angle	IN. & EX.	45°	
Valve head radial runout	IN. & EX.	—	0.03
Valve spring free length	IN.	—	37.8
	EX.	—	37.8
Valve spring tension	IN.	12.1~13.9kgf (at length 33.7mm)	—
	EX.	12.1~13.9kgf (at length 33.7mm)	—

CAMSHAFT + CYLINDER HEAD

Unit : mm

ITEM	STANDARD		LIMIT
Cam height	IN.	34.470 ~ 34.510	34.170
	EX.	34.420 ~ 34.460	34.120
Camshaft journal holder I.D.	IN. & EX.	35.000 ~ 35.018	—
Cylinder head distortion	—		0.05
Cylinder head cover distortion	—		0.05
Cam chain pin (Arrow "3")	16th pin		—

CYLINDER + PISTON + PISTON RING

Unit : mm

ITEM	STANDARD		LIMIT
Compression pressure	14~16 kg/cm ² (at 600 rpm)		12 kg/cm ²
Piston to cylinder clearance	0.050~0.060		0.120
Cylinder bore	57.000~57.015		57.080
Piston diam.	56.945~56.960 (Measure at 15mm from the skirt end)		56.880
Cylinder or cylinder head distortion	—		0.05
Piston ring free end gap	1st	7.2	5.7
	2nd	5.8	4.6
Piston ring end gap (Assembly condition)	1st	0.20~0.32	0.5
	2nd	0.20~0.32	0.5
Piston ring to groove clearance	1st	—	0.180
	2nd	—	0.150
Piston ring to groove width	1st	1.01~1.03	—
	2nd	1.01~1.03	—
	Oil	2.01~2.03	—
Piston ring thickness	1st	0.970~0.990	—
	2nd	0.970~0.990	—
Piston pin hall I.D.	15.002 ~ 15.008		15.030
Piston pin O.D.	14.994 ~ 15.000		14.980

CONROD + CRANKSHAFT

Unit : mm

ITEM	STANDARD		LIMIT
Conrod small end I.D.	15.006~15.014		15.040
Conrod deflection	—		3.0
Conrod big end side clearance	0.40~0.85		1.0
Conrod big end width	15.95~16.00		—
Crank web to web width	72 ± 0.1		—
Crankshaft runout	—		0.05

OIL PUMP

Unit : mm

ITEM	STANDARD	NOTE
Oil pressure	1.3 ± 0.2 kg/cm ² (at 60 °C, 4,000 rpm)	—
Oil pump reduction ratio	58/19 × 14/20=2.137	—

7-15 SERVICING INFORMATION

CLUTCH

Unit : mm

ITEM	STANDARD	LIMIT
Clutch cable play	4	—
Drive plate thickness	2.9~3.1	2.6
Drive plate claw width	11.8~12.0	11.0
Driven plate distortion	—	0.1
Clutch spring free length	38.2	36.2

TRANSMISSION + DRIVE CHAIN

Unit : mm

ITEM	STANDARD		LIMIT
Primary reduction ratio	3.05 (58/19)		—
Secondary reduction ratio	3.29 (46/14)		—
Gear ratio	1st	2.46 (32/13)	—
	2nd	1.56 (28/18)	—
	3rd	1.19 (25/21)	—
	4th	0.96 (22/23)	—
	5th	0.84 (21/25)	—
Shift fork to groove clearance	0.10~0.30		0.5
Shift fork groove width	NO.1 & NO.2	5.0~5.1	—
	NO.3	5.0~5.1	—
Shift fork thickness	NO.1 & NO.2	4.8~4.9	—
	NO.3	4.8~4.9	—
	Type	RK-520DS	—
Drive chain	Links	116 LINKS	—
	20-pitch length	317.5	319.4
Drive chain slack	20~30		—

CARBURETOR

Unit : mm

ITEM	SPECIFICATION							
Carburetor type	MIKUNI BDS26TYPE(DOUBLE)							
Bore size	φ 26							
I.D. NO.	HJ 82							
Idle r.p.m.	1,450~1,550 r.p.m.							
Float height	17							
Throttle cable play	0.5~1.0							
	FRONT				REAR			
Main jet (M.J.)	90				87.5			
Main air jet (M.A.J.)	140				140			
Jet needle (J.N.)	2ND				2ND			
Needle jet (N.J.)	O-6				6			
Pilot jet (P.J.)	20				20			
Throttle valve (TH.V.)	130				130			
By-pass (B.P.)	#1	#2	#3	#4	#1	#2	#3	#4
	0.9	0.9	0.8	0.8	0.9	0.9	0.8	0.8
Valve seat (V.S.)	1.2				1.2			
Starter jet (G.S.)	22.5				22.5			
Pilot outlet (P.O.)	0.75				0.75			
PV. Stroke (P.V.)	STD				STD			

7-17 SERVICING INFORMATION

ELECTRICAL

Unit : mm

ITEM	STANDARD		NOTE
Ignition timing	13°/2,000rpm ~ 30°/6,000rpm		
Spark plug	Type	CR8E	
	Gap	0.7~0.8	
	Hot type	CR7E	
	Standard type	CR8E	
	Cold type	CR9E	
Spark performance	Over 8mm		
Ignition coil resistance	Primary	0.19~0.34Ω	
	Secondary	5.4~6.6kΩ	
Magneto coil resistance	Pick-up coil	90~110Ω	G-L
	Charging coil	0.6~0.9Ω	Y-Y
Generator no-load voltage	72~99V/5,000rpm		
Regulated voltage	14~15V		
Battery standard charging voltage	13.5~16.0V/5,000rpm		
Battery	Type	YTX7A-BS	
	Capacity	6Ah	
	Standard electrolyte S.G.	1.320[at 20°C(60°F)]	
Fuse size	15A		

WATTAGE

Unit : W

ITEM	SPECIFICATION	
Head lamp	HI	35W
	LO	35W
Position lamp	5W	
License lamp	5W	
Brake/Tail lamp	21/5W	
Turn signal lamp	10W	
Speedometer lamp	1.7W×3	
Neutral lamp	1.7W	
Turn signal indicator lamp (Right & left)	1.7W×2	
High beam indicator lamp	1.7W	

CAUTION

Do not use except the specified bulb (Wattage).

SUSPENSION

Unit : mm

ITEM	STANDARD	LIMIT
Front fork stroke	120	—
Front fork spring free length	361	356
Front fork oil type	TELLUS #22	—
Front fork oil level	325	—
Front fork oil capacity (each leg)	250cc	—
Rear wheel travel	92	—
Swingarm pivot shaft runout	—	0.6
Rear shock absorber pre-load position	1 / 5 position	—
Rear shock absorber spring length	199.8	195

BRAKE+WHEEL

Unit : mm

ITEM	STANDARD		LIMIT
Rear brake pedal free travel	20~30		—
Rear brake pedal height	310 (when one person riding from the ground)		—
Brake disc thickness	Front	4.0	3.0
Brake disc runout	Front	—	0.3
Master cylinder bore	12.700~12.743		—
Master cylinder piston diam	12.657~12.684		—
Brake caliper cylinder bore	25.4		—
Brake caliper piston diam	25.4		—
Brake fluid type	DOT3 or DOT4		—
Brake drum I.D.	Rear	—	160.7
Wheel rim runout	Axial	—	2.0
	Radial	—	2.0
Wheel axle runout	Front	—	0.25
	Rear	—	0.25
Wheel rim size	Front	2.5 × 16	—
	Rear	3.0 × 15	—

7-19 SERVICING INFORMATION

TIRE

ITEM	STANDARD		LIMIT
Cold inflation tire pressure (Solo riding)	Front	1.75	—
	Rear	2.00	—
Cold inflation tire pressure (Dual riding)	Front	1.75	—
	Rear	2.25	—
Tire tread depth	Front	—	5.5
	Rear	—	8.0

FUEL + OIL

ITEM	SPECIFICATION		NOTE
Fuel type	Gasoline used should be graded 91 octane or higher. An unleaded gasoline is recommended.		
Fuel tank capacity	Including reserve	14.0 ℓ	
	Reserve	2.0 ℓ	
Engine oil type	SAE 10W40		
Engine oil capacity	Change	1,450 mℓ	
	Filter change	1,500 mℓ	
	Overhaul	1,800 mℓ	

WIRE AND CABLE ROUTING

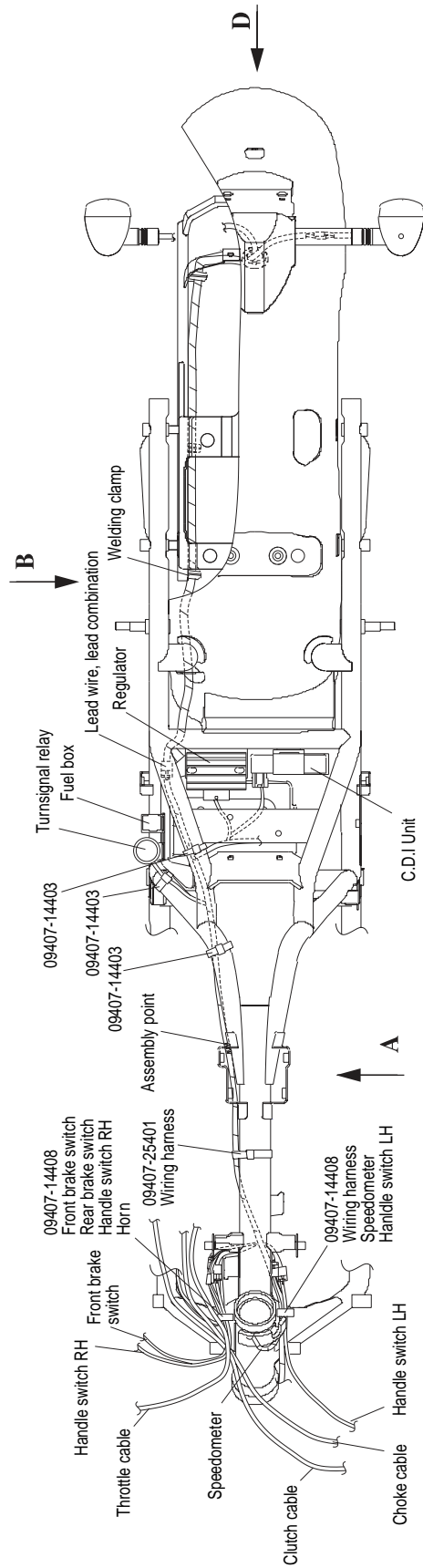

7-21 SERVICING INFORMATION

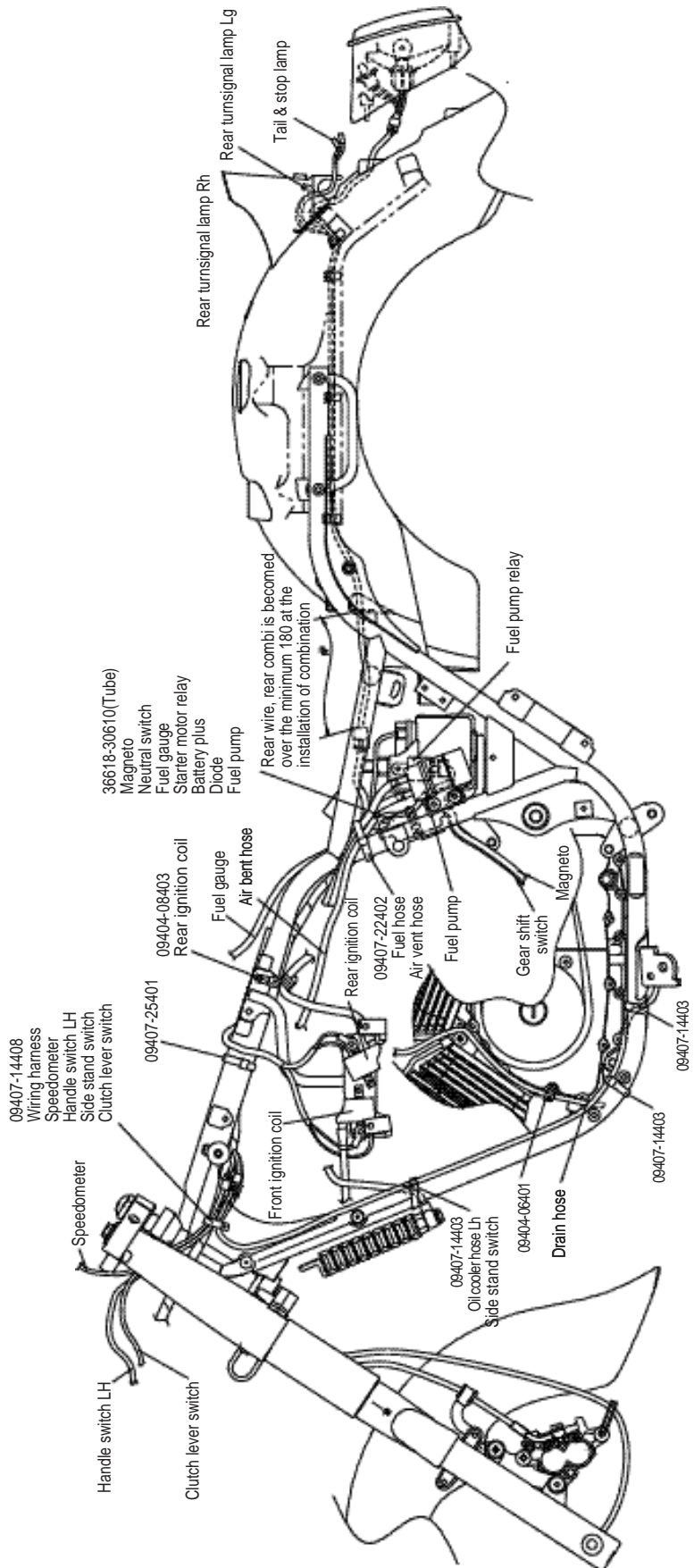

VIEW A

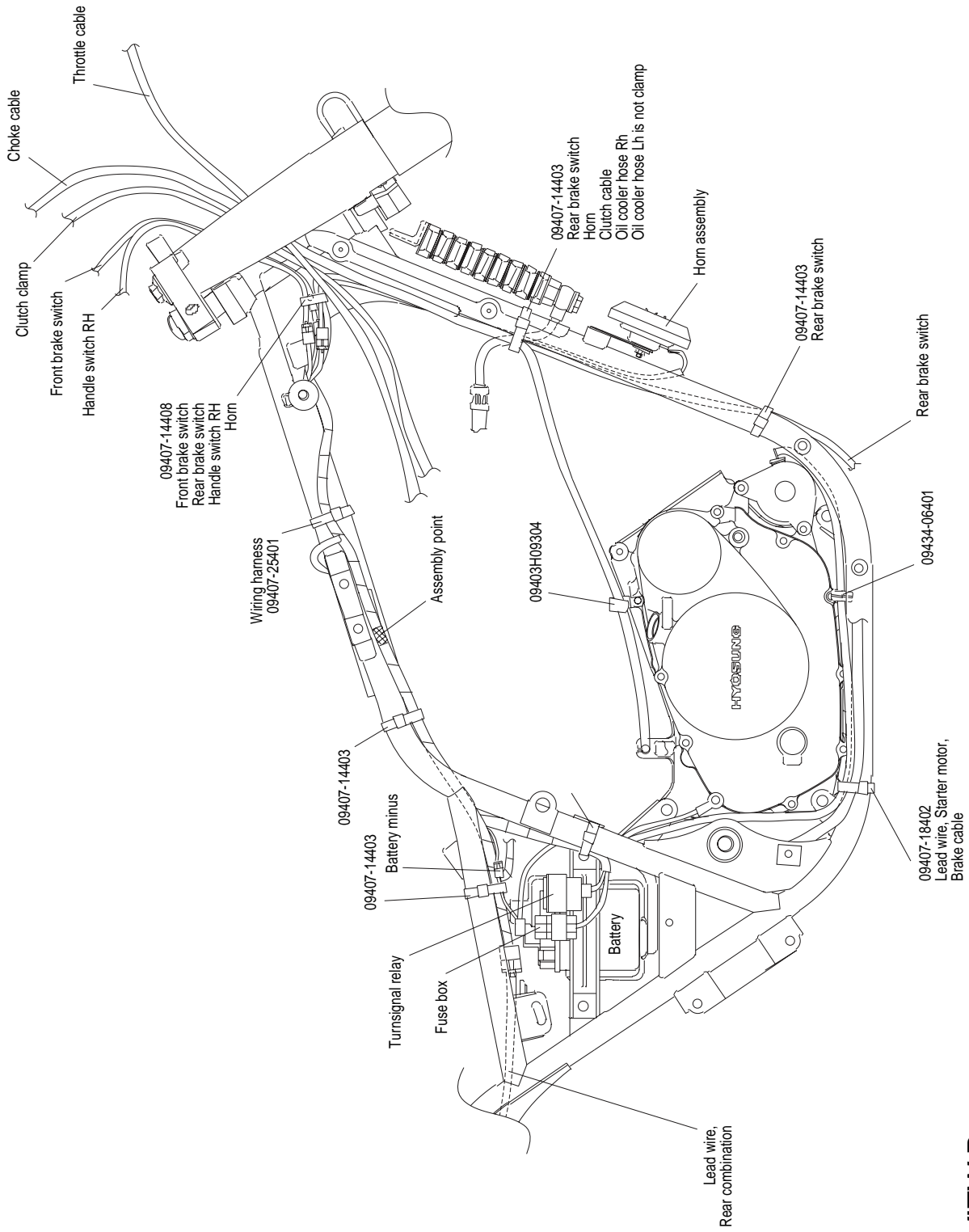

VIEW B

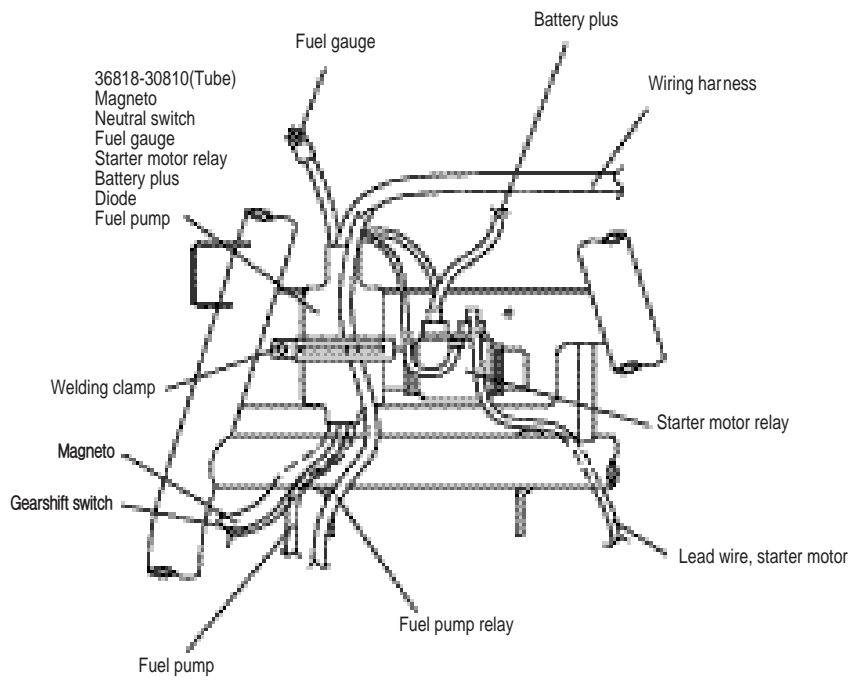
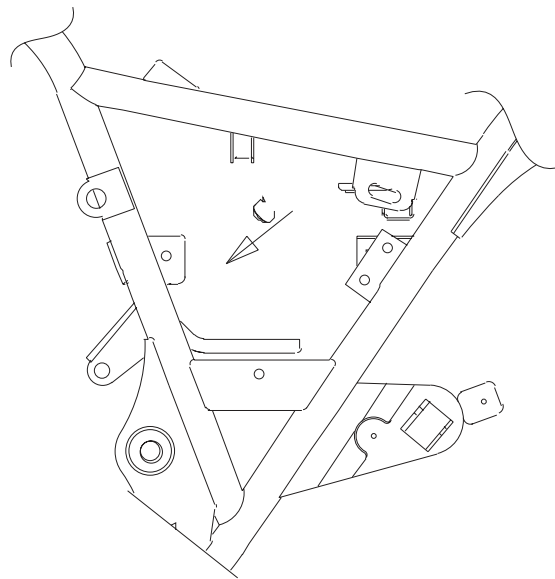

VIEW C

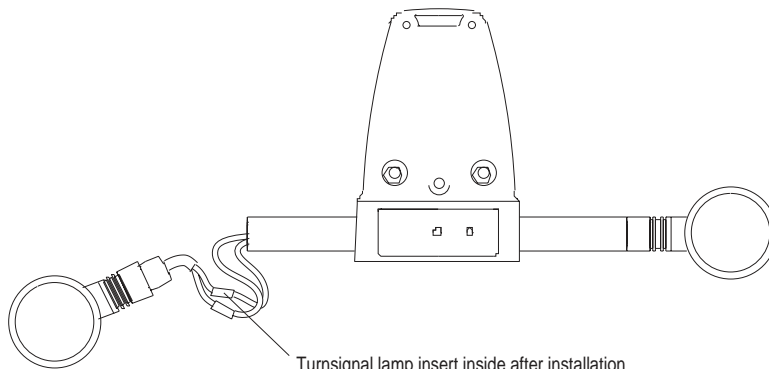

VIEW D

WIRING DIAGRAM

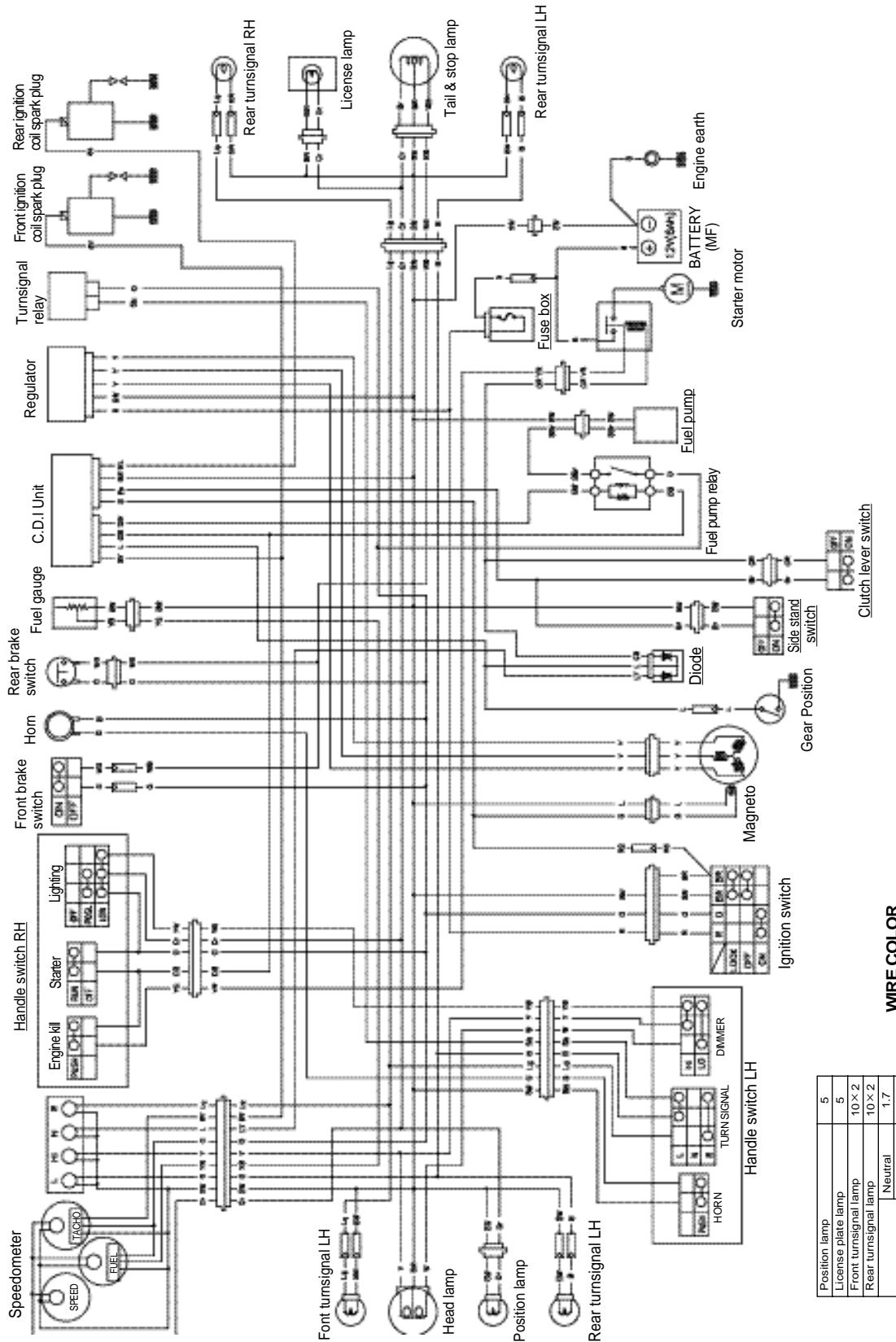

Position lamp	5
License plate lamp	5
Front turnsignal lamp	10×2
Rear turnsignal lamp	10×2
Indicator lamp	1.7
Neutral	1.7
High beam	1.7×2
turnsignal	1.7×3
Speedometer	5
Tail & stop lamp	21
Lamp	H/L/O 35/35
	DIST
	W

WIRE COLOR

- B : Black
- Br : Brown
- G : Green
- Gr : Gray
- L : Blue
- Lg : Light green
- O : Orange
- R : Red
- Sb : Light blue
- W : White
- Y : Yellow
- BG : Black with Green tracer
- BW : Black with White tracer
- BR : Black with Red tracer
- WL : White with Blue tracer
- OB : Orange with Black tracer
- RB : Red with Black tracer
- RW : Red with White tracer
- WB : White with Black tracer
- WR : White with Red tracer
- BY : Black with Yellow tracer
- GW : Green with White tracer

TAPPET SHIM SELECTION CHART (IN.)

SHIM No.	120	125	130	135	140	145	150	155	160	165	170	175	180	185	190	195	200	205	210	215	220
	Specified clearance - Adjustment unnecessary																				
MEASURING TAPPET CLEARANCE (mm)	1.20	1.25	1.30	1.35	1.40	1.45	1.50	1.55	1.60	1.65	1.70	1.75	1.80	1.85	1.90	1.95	2.00	2.05	2.10	2.15	2.20
SHIM THICKNESS AT PRESENT (mm)	1.20	1.25	1.30	1.35	1.40	1.45	1.50	1.55	1.60	1.65	1.70	1.75	1.80	1.85	1.90	1.95	2.00	2.05	2.10	2.15	2.20
0.00-0.04			1.20	1.25	1.30	1.35	1.40	1.45	1.50	1.55	1.60	1.65	1.70	1.75	1.80	1.85	1.90	1.95	2.00	2.05	2.10
0.05-0.09		1.20	1.25	1.30	1.35	1.40	1.45	1.50	1.55	1.60	1.65	1.70	1.75	1.80	1.85	1.90	1.95	2.00	2.05	2.10	2.15
0.10-0.20																					
0.21-0.25	1.30	1.35	1.40	1.45	1.50	1.55	1.60	1.65	1.70	1.75	1.80	1.85	1.90	1.95	2.00	2.05	2.10	2.15	2.20		
0.26-0.30	1.35	1.40	1.45	1.50	1.55	1.60	1.65	1.70	1.75	1.80	1.85	1.90	1.95	2.00	2.05	2.10	2.15	2.20			
0.31-0.35	1.40	1.45	1.50	1.55	1.60	1.65	1.70	1.75	1.80	1.85	1.90	1.95	2.00	2.05	2.10	2.15	2.20				
0.36-0.40	1.45	1.50	1.55	1.60	1.65	1.70	1.75	1.80	1.85	1.90	1.95	2.00	2.05	2.10	2.15	2.20					
0.41-0.45	1.50	1.55	1.60	1.65	1.70	1.75	1.80	1.85	1.90	1.95	2.00	2.05	2.10	2.15	2.20						
0.46-0.50	1.55	1.60	1.65	1.70	1.75	1.80	1.85	1.90	1.95	2.00	2.05	2.10	2.15	2.20							
0.51-0.55	1.60	1.65	1.70	1.75	1.80	1.85	1.90	1.95	2.00	2.05	2.10	2.15	2.20								
0.56-0.60	1.65	1.70	1.75	1.80	1.85	1.90	1.95	2.00	2.05	2.10	2.15	2.20									
0.61-0.65	1.70	1.75	1.80	1.85	1.90	1.95	2.00	2.05	2.10	2.15	2.20										
0.66-0.70	1.75	1.80	1.85	1.90	1.95	2.00	2.05	2.10	2.15	2.20											
0.71-0.75	1.80	1.85	1.90	1.95	2.00	2.05	2.10	2.15	2.20												
0.76-0.80	1.85	1.90	1.95	2.00	2.05	2.10	2.15	2.20													
0.81-0.85	1.90	1.95	2.00	2.05	2.10	2.15	2.20														
0.86-0.90	1.95	2.00	2.05	2.10	2.15	2.20															
0.91-0.95	2.00	2.05	2.10	2.15	2.20																
0.96-1.00	2.05	2.10	2.15	2.20																	
1.01-1.05	2.10	2.15	2.20																		
1.06-1.10	2.15	2.20																			
1.11-1.15	2.20																				

HOW TO USE THE CHART

1. Measure the tappet clearance.(When cold)
2. Measure the shim thickness at present.
3. Look for meeting space in that horizontal line for thickness and vertical line for clearance.

(EXAMPLE)

When the tappet clearance is 0.23mm and the shim thickness at present is 1.70mm, the shim thickness should be used 1.80mm.

TAPPET SHIM SELECTION CHART (EX.)

SHIM No. MEASURING TAPPET CLEARANCE (mm)	120	125	130	135	140	145	150	155	160	165	170	175	180	185	190	195	200	205	210	215	220	
	Specified clearance - Adjustment unnecessary																					
0.05-0.09	1.20	1.25	1.30	1.35	1.40	1.45	1.50	1.55	1.60	1.65	1.70	1.75	1.80	1.85	1.90	1.95	2.00	2.05	2.10	2.15	2.20	
0.10-0.14	1.20	1.25	1.30	1.35	1.40	1.45	1.50	1.55	1.60	1.65	1.70	1.75	1.80	1.85	1.90	1.95	2.00	2.05	2.10	2.15	2.20	
0.15-0.19	1.20	1.25	1.30	1.35	1.40	1.45	1.50	1.55	1.60	1.65	1.70	1.75	1.80	1.85	1.90	1.95	2.00	2.05	2.10	2.15	2.20	
0.20-0.30	Specified clearance - Adjustment unnecessary																					
0.31-0.35	1.30	1.35	1.40	1.45	1.50	1.55	1.60	1.65	1.70	1.75	1.80	1.85	1.90	1.95	2.00	2.05	2.10	2.15	2.20	2.20	2.20	
0.36-0.40	1.35	1.40	1.45	1.50	1.55	1.60	1.65	1.70	1.75	1.80	1.85	1.90	1.95	2.00	2.05	2.10	2.15	2.20	2.20	2.20	2.20	
0.41-0.45	1.40	1.45	1.50	1.55	1.60	1.65	1.70	1.75	1.80	1.85	1.90	1.95	2.00	2.05	2.10	2.15	2.20	2.20	2.20	2.20	2.20	
0.46-0.50	1.45	1.50	1.55	1.60	1.65	1.70	1.75	1.80	1.85	1.90	1.95	2.00	2.05	2.10	2.15	2.20	2.20	2.20	2.20	2.20	2.20	
0.51-0.55	1.50	1.55	1.60	1.65	1.70	1.75	1.80	1.85	1.90	1.95	2.00	2.05	2.10	2.15	2.20	2.20	2.20	2.20	2.20	2.20	2.20	
0.56-0.60	1.55	1.60	1.65	1.70	1.75	1.80	1.85	1.90	1.95	2.00	2.05	2.10	2.15	2.20	2.20	2.20	2.20	2.20	2.20	2.20	2.20	
0.61-0.65	1.60	1.65	1.70	1.75	1.80	1.85	1.90	1.95	2.00	2.05	2.10	2.15	2.20	2.20	2.20	2.20	2.20	2.20	2.20	2.20	2.20	
0.66-0.70	1.65	1.70	1.75	1.80	1.85	1.90	1.95	2.00	2.05	2.10	2.15	2.20	2.20	2.20	2.20	2.20	2.20	2.20	2.20	2.20	2.20	
0.71-0.75	1.70	1.75	1.80	1.85	1.90	1.95	2.00	2.05	2.10	2.15	2.20	2.20	2.20	2.20	2.20	2.20	2.20	2.20	2.20	2.20	2.20	
0.76-0.80	1.75	1.80	1.85	1.90	1.95	2.00	2.05	2.10	2.15	2.20	2.20	2.20	2.20	2.20	2.20	2.20	2.20	2.20	2.20	2.20	2.20	
0.81-0.85	1.80	1.85	1.90	1.95	2.00	2.05	2.10	2.15	2.20	2.20	2.20	2.20	2.20	2.20	2.20	2.20	2.20	2.20	2.20	2.20	2.20	
0.86-0.90	1.85	1.90	1.95	2.00	2.05	2.10	2.15	2.20	2.20	2.20	2.20	2.20	2.20	2.20	2.20	2.20	2.20	2.20	2.20	2.20	2.20	
0.91-0.95	1.90	1.95	2.00	2.05	2.10	2.15	2.20	2.20	2.20	2.20	2.20	2.20	2.20	2.20	2.20	2.20	2.20	2.20	2.20	2.20	2.20	
0.96-1.00	1.95	2.00	2.05	2.10	2.15	2.20	2.20	2.20	2.20	2.20	2.20	2.20	2.20	2.20	2.20	2.20	2.20	2.20	2.20	2.20	2.20	
1.01-1.05	2.00	2.05	2.10	2.15	2.20	2.20	2.20	2.20	2.20	2.20	2.20	2.20	2.20	2.20	2.20	2.20	2.20	2.20	2.20	2.20	2.20	
1.06-1.10	2.05	2.10	2.15	2.20	2.20	2.20	2.20	2.20	2.20	2.20	2.20	2.20	2.20	2.20	2.20	2.20	2.20	2.20	2.20	2.20	2.20	
1.11-1.15	2.10	2.15	2.20	2.20	2.20	2.20	2.20	2.20	2.20	2.20	2.20	2.20	2.20	2.20	2.20	2.20	2.20	2.20	2.20	2.20	2.20	
1.16-1.20	2.15	2.20	2.20	2.20	2.20	2.20	2.20	2.20	2.20	2.20	2.20	2.20	2.20	2.20	2.20	2.20	2.20	2.20	2.20	2.20	2.20	
1.21-1.25	2.20	2.20	2.20	2.20	2.20	2.20	2.20	2.20	2.20	2.20	2.20	2.20	2.20	2.20	2.20	2.20	2.20	2.20	2.20	2.20	2.20	

HOW TO USE THE CHART

1. Measure the tappet clearance. (When cold)
2. Measure the shim thickness at present.
3. Look for meeting space in that horizontal line for thickness and vertical line for clearance.

(EXAMPLE)

When the tappet clearance is 0.33mm and the shim thickness at present is 1.70mm, the shim thickness should be used 1.80mm.



Prepared by

HYOSUNG MOTORS & MACHINERY INC.

Overseas Technical Department

2nd Ed. MAY. 2001.

Manual No. 99000-95310

Printed in Korea