

HYOSUNG

HYOSUNG

Comet 250
Comet 125

Comet 250 / 125

HYOSUNG MOTORS & MACHINERY INC.

SERVICE MANUAL

SERVICE MANUAL

99000-94710

FOREWORD

This manual contains an introductory description on HYOSUNG[®] Comet 250[Ⓜ] / Comet 125[Ⓜ] and procedures for its inspection/service and overhaul of its main components.

Other information considered as generally known is not included.

Read GENERAL INFORMATION section to familiarize yourself with outline of the vehicle and MAINTENANCE and other sections to use as a guide for proper inspection and service.

This manual will help you know the vehicle better so that you can assure your customers of your optimum and quick service.

- ❖ This manual has been prepared on the basis of the latest specification at the time of publication. If modification has been made since then, difference may exist between the content of this manual and the actual vehicle.
- ❖ Illustrations in this manual are used to show the basic principles of operation and work procedures. They may not represent the actual vehicle exactly in detail.

WARNING

This manual is intended for those who have enough knowledge and skills for servicing HYOSUNG vehicles. Without such knowledge and skills, you should not attempt servicing by relying on this manual only.

Instead, please contact your nearby authorized HYOSUNG motorcycle dealer.

GROUP INDEX

GENERAL INFORMATION

1

PERIODIC MAINTENANCE

2

ENGINE

3

FUEL SYSTEM

4

ELECTRICAL SYSTEM

5

CHASSIS

6

SERVICING INFORMATION

7

 **HYOSUNG MOTORS & MACHINERY INC.**

HOW TO USE THIS MANUAL

TO LOCATE WHAT YOU ARE LOOKING FOR:

1. The text of this manual is divided into sections.
2. As the title of these sections are listed on the previous page as GROUP INDEX, select the section where you are looking for.
3. Holding the manual as shown at the right will allow you to find the first page of the section easily.
4. On the first page of each section, its contents are listed. Find the item and page you need.

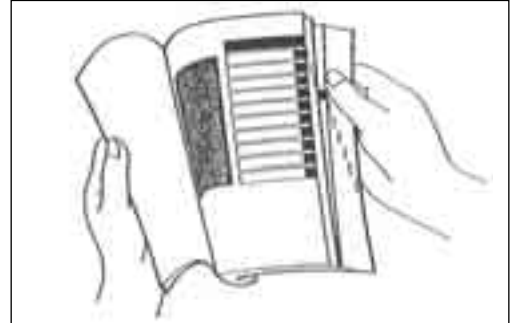





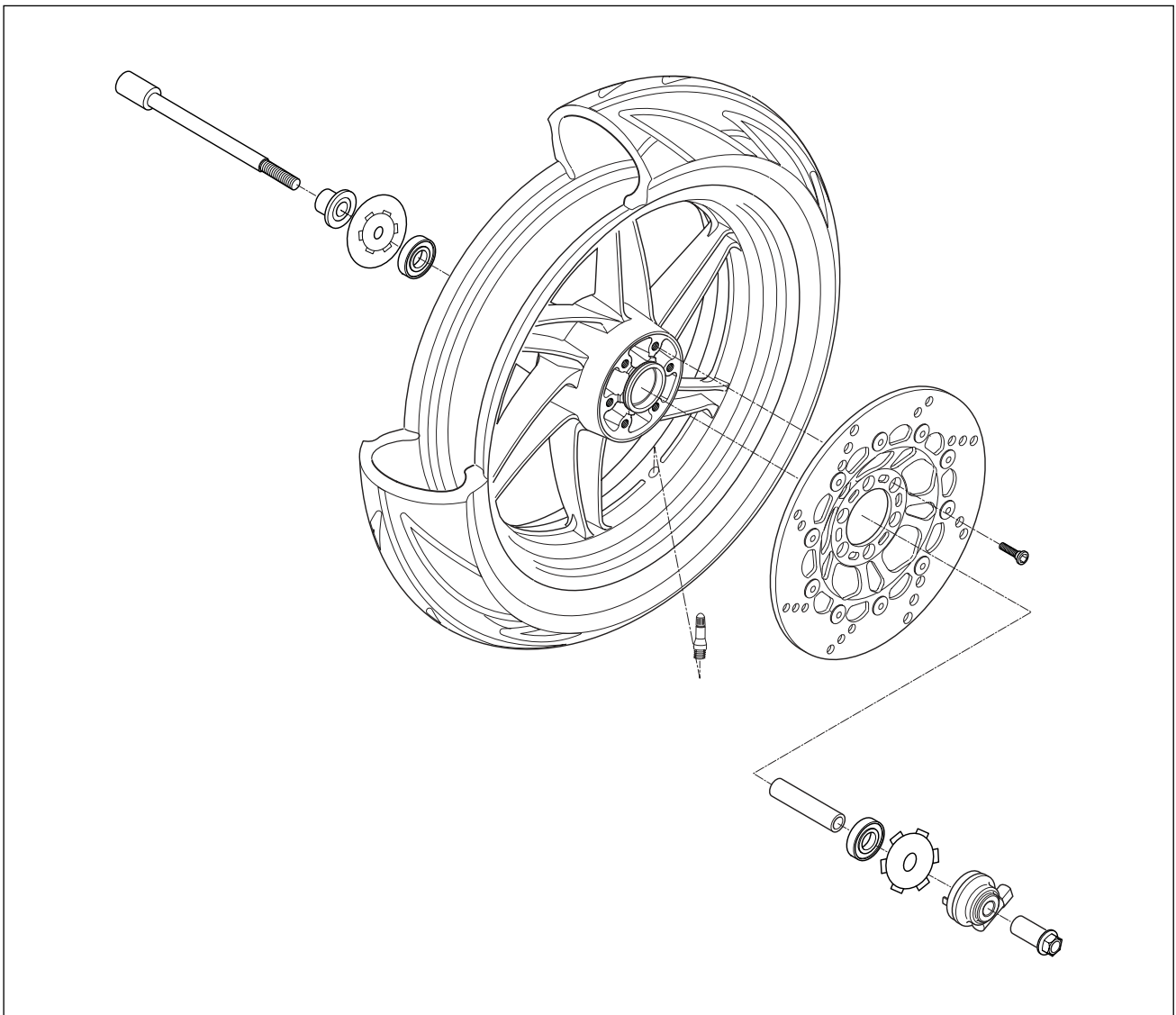







COMPONENT PARTS

Example: Front wheel



SYMBOL

Listed in the table below are the symbols indicating instructions and other information necessary for servicing and meaning associated with them respectively.

SYMBOL	DEFINITION	SYMBOL	DEFINITION
	Torque control required. Data beside it indicates specified torque.		Apply THREAD LOCK "1324".
	Apply oil. Use engine oil unless otherwise specified.		Apply or use brake fluid.
	Apply SUPER GREASE "A".		Measure in voltage range.
	Apply SUPER GREASE "C".		Measure in resistance range.
	Apply SILICONE GREASE.		Measure in current range.
	Apply MOLY PASTE.		Use special tool.
	Apply BOND "1215".		



『 Comet 250 』



『 Comet 125 』

NOTE

Difference between photographs and actual motorcycles depends on the markets.

GENERAL INFORMATION

CONTENTS

INFORMATION LABELS	1-1
GENERAL PRECAUTIONS	1-1
SERIAL NUMBER LOCATION	1-3
FUEL AND OIL RECOMMENDATIONS	1-4
BREAK-IN PROCEDURES	1-5
CYLINDER CLASSIFICATION	1-5
EXTERIOR ILLUSTRATION	1-6
SPECIFICATIONS	1-8

1-1 GENERAL INFORMATION

WARNING / CAUTION / NOTE

Please read this manual and follow its instructions carefully. To emphasize special information, the symbol and the words WARNING, CAUTION and NOTE have special meanings. Pay special attention to the messages highlighted by these signal words.

WARNING

Indicates a potential hazard that could result in death or injury.

CAUTION

Indicates a potential hazard that could result in vehicle damage.

NOTE

Indicates special information to make maintenance easier or instructions clearer.

Please note, however, that the warning and cautions contained in this manual cannot possibly cover all potential hazards relating to the servicing, or lack of servicing, of the motorcycle. In addition to the WARNING and CAUTION stated, you must use good judgement and basic mechanical safety principles. If you are unsure about how to perform a particular service operation, ask a more experienced mechanic for advice.

GENERAL PRECAUTIONS

WARNING

- ❖ Proper service and repair procedures are important for the safety of the service machanic and the safety and reliability of the vehicle.
- ❖ When 2 or more persons work together, pay attention to the safety of each other.
- ❖ When it is necessary to run the engine indoors, make sure that exhaust gas is forced outdoors.
- ❖ When working with toxic or flammable materials, make sure that the area you work in is well-ventilated and that you follow all off the material manufacturer' s instructions.
- ❖ Never use gasoline as a cleaning solvent.
- ❖ To avoid getting burned, do not touch the engine, engine oil or exhaust system during or for a while after engine operation.
- ❖ After servicing fuel, oil, exhaust or brake systems, check all lines and fittings related to the system for leaks.

 **WARNING**

- ❖ If parts replacement is necessary, replace the parts with HYOSUNG Genuine Parts or their equivalent.
- ❖ When removing parts that are to be reused, keep them arranged in an orderly manner so that they may be reinstalled in the proper order and orientation.
- ❖ Be sure to use special tools when instructed.
- ❖ Make sure that all parts used in reassembly are clean, and also lubricated when specified.
- ❖ When use of a certain type of lubricant, bond, or sealant is specified, be sure to use the specified type.
- ❖ When removing the battery, disconnect the negative cable first and then positive cable. When reconnecting the battery, connect the positive cable first and then negative cable, and replace the terminal cover on the positive terminal.
- ❖ When performing service to electrical parts, if the service procedures do not require use of battery power, disconnect the negative cable at the battery.
- ❖ Tighten cylinder head and case bolts and nuts, beginning with larger diameter and ending with smaller diameter, from inside to outside diagonally, to the specified tightening torque.
- ❖ Whenever you remove oil seals, gaskets, packing, O-rings, locking washers, cotter pins, circlips, and certain other parts as specified, be sure to replace them with new ones. Also, before installing these new parts, be sure to remove any left over material from the mating surfaces.
- ❖ Never reuse a circlip. When installing a new circlip, take care not to expand the end gap larger than required to slip the circlip over the shaft. After installing a circlip, always ensure that it is completely seated in its groove and securely fitted.
- ❖ Do not use self-locking nuts a few times over.
- ❖ Use a torque wrench to tighten fasteners to the torque values when specified. Wipe off grease or oil if a thread is smeared with them.
- ❖ After reassembly, check parts for tightness and operation.

 **WARNING**

- ❖ To protect environment, do not unlawfully dispose of used motor oil and other fluids: batteries, and tires.
- ❖ To protect Earth's natural resources, properly dispose of used vehicles and parts.

SERIAL NUMBER LOCATION

The frame serial number or V.I.N. (Vehicle Identification Number) is stamped on the steering head tube. The engine serial number is located on the left upside of crankcase assembly.

These numbers are required especially for registering the machine and ordering spare parts.

⦿ FRAME SERIAL NUMBER

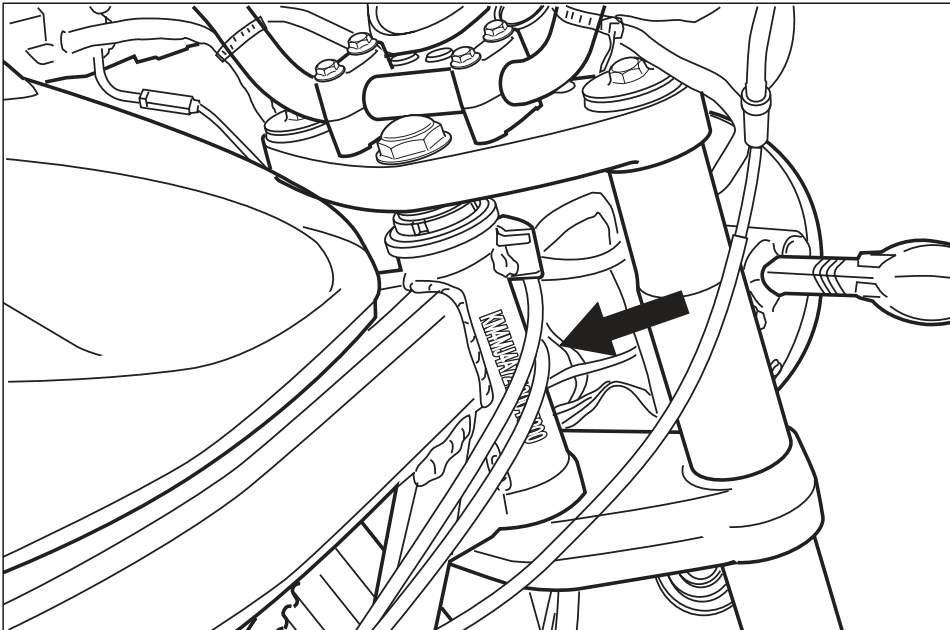

⦿ ENGINE SERIAL NUMBER

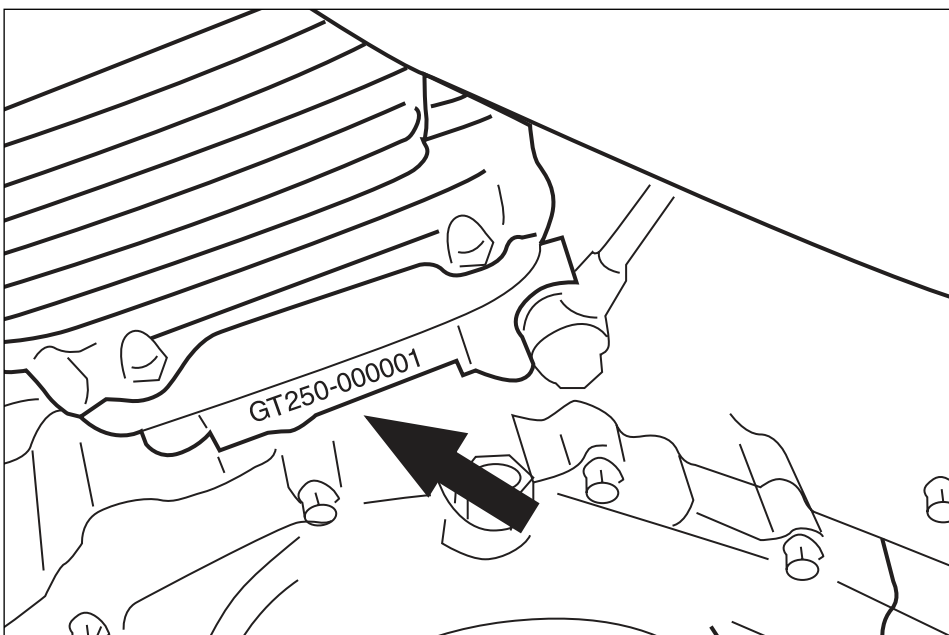

FUEL AND OIL RECOMMENDATION

⦿ FUEL

Gasoline used should be graded 85~95 octane (Research Method) or higher. An unleaded gasoline type is recommended.

⦿ ENGINE OIL

■ ENGINE OIL SPECIFICATION

Classification system	Grade
API	Over SG
SAE	10W/30 or 10W/40

* If an SAE 10W/30 or 10W/40 motor oil is not available, select an alternative according to the following chart.

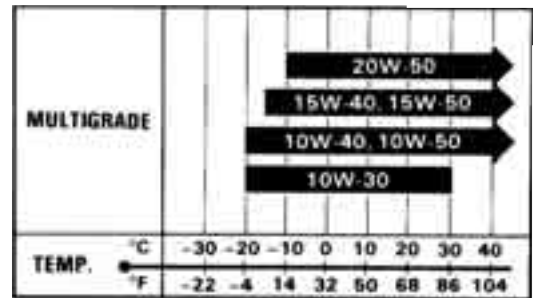

Use a premium quality 4-stroke motor oil to ensure longer service life of your motorcycle.

⚠ WARNING

- ❖ Don't mix the unrecommended oil. It could damage the engine.
- ❖ When refilling the oil tank, don't allow the dust to get inside.
- ❖ Mop the oil spilt.
- ❖ Don't put the patch on the cap. It could disturb the oil to be provided and damage the engine.

⦿ BRAKE FLUID

Specification and classification: DOT3 or DOT4

⚠ WARNING

Since the brake system of this motorcycle is filled with a glycol-based brake fluid by the manufacturer, do not use or mix different types of fluid such as silicone-based and petroleum-based fluid for refilling the system, otherwise serious damage will result.

Do not use any brake fluid taken from old or used or unsealed containers.

Never re-use brake fluid left over from a previous servicing, which has been stored for a long period.

⦿ FRONT FORK OIL

Use fork oil : TELLUS #22

BREAK-IN PROCEDURES

During manufacture only the best possible materials are used and all machined parts are finished to a very high standard but it is still necessary to allow the moving parts to “BREAK-IN” before subjecting the engine to maximum stresses. The future performance and reliability of the engine depends on the care and restraint exercised during its early life. The general rules are as follows:

- Keep to these break-in procedures:

Initial 800km	Less than 1/2 throttle
Up to 1,600km	Less than 3/4 throttle

- Upon reaching an odometer reading of 1,600 km you can subject the motorcycle to full throttle operation.
- Do not maintain constant engine speed for an extended period during any portion of the break-in. Try to vary the throttle position.

CYLINDER CLASSIFICATION

The engine of 『Comet 250』 / 『Comet 125』 is composed of the two cylinder, is classified into the front cylinder and rear cylinder as basis of the motorcycle ahead.

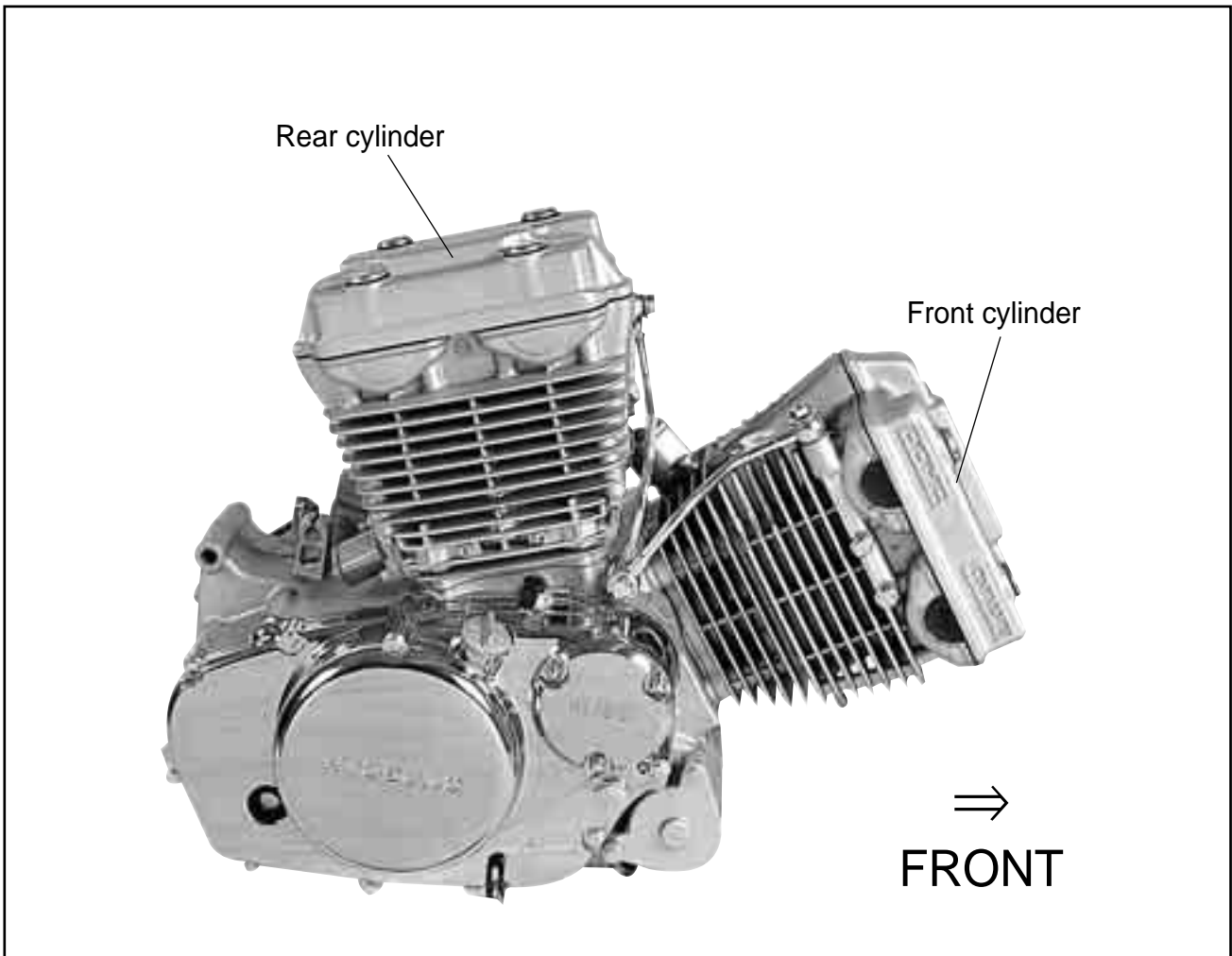

EXTERIOR ILLUSTRATION(『Comet-250』)

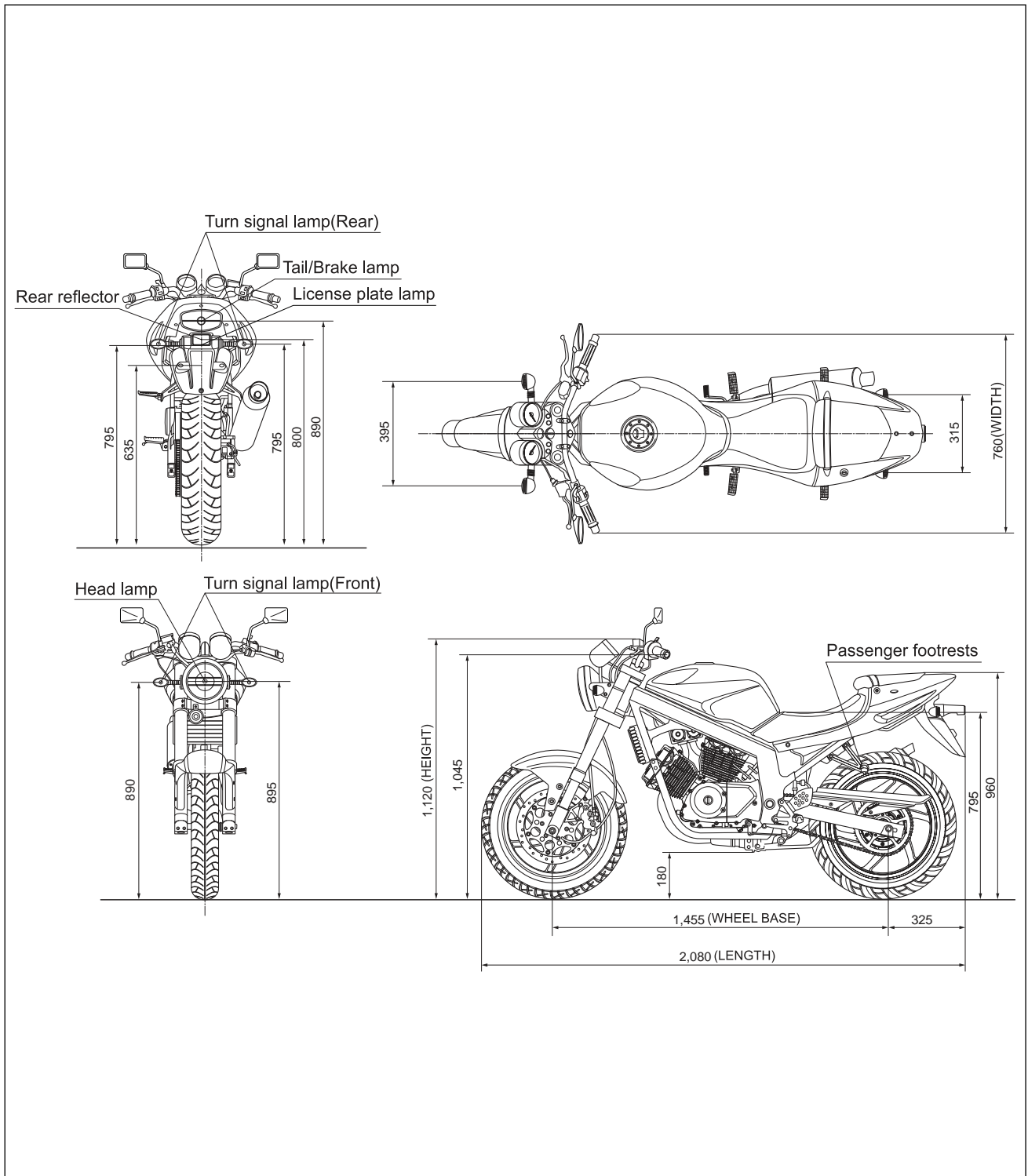

1-7 GENERAL INFORMATION

EXTERIOR ILLUSTRATION(『 Comet 125 』)

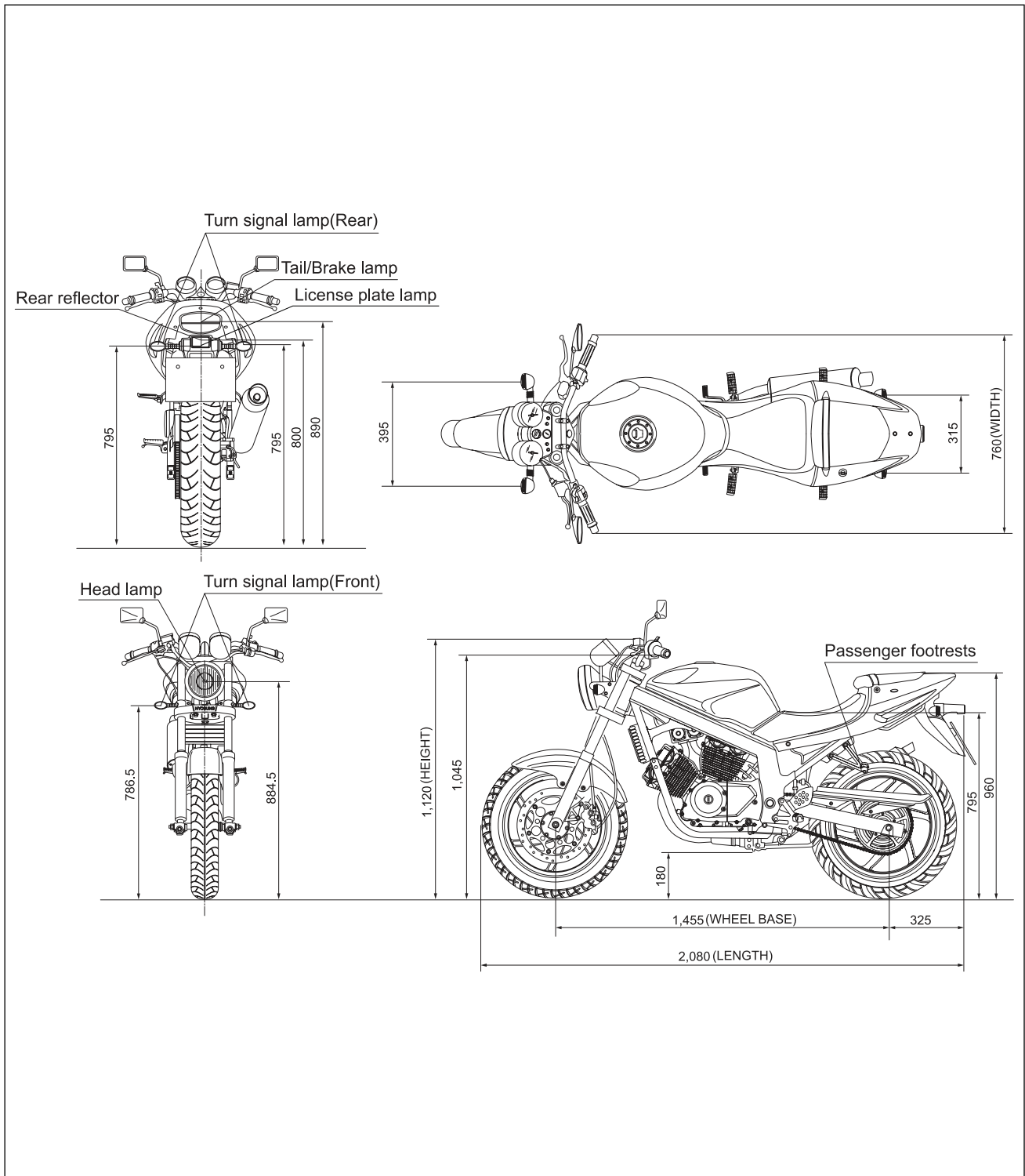

SPECIFICATIONS

DIMENSIONS AND DRY MASS

	<i>Comet 250</i>	<i>Comet 125</i>
Overall length	2,080 mm (81.9 in)	←
Overall width	760 mm (29.9 in)	←
Overall height	1,120 mm (44.1 in)	←
Wheelbase	1,455 mm (53.7 in)	←
Ground clearance	180 mm (7.1 in)	←
Unladen mass	170 kg (375 lbs)	167 kg (368 lbs)

ENGINE

	<i>Comet 250</i>	<i>Comet 125</i>
Type	Four-stroke, DOHC, air-cooled and oil-cooled	←
Number of cylinder	V-2 cylinder	←
Bore	57.0 mm (2.24 in)	44.0 mm (1.73 in)
Stroke	48.8 mm (1.92 in)	41.0 mm (1.61 in)
Piston displacement	249 cm^3 (15.2 in^3)	124.7 cm^3 (7.6 in^3)
Carburetor	BDS 26TYPE (DOUBLE)	←
Starter system	Electric starter	←
Lubrication system	Wet sump	←

TRANSMISSION

	<i>Comet 250</i>	<i>Comet 125</i>
Clutch	Wet multi-plate type	←
Transmission	5-speed constant mesh	←
Gearshift pattern	1-down, 4-up	←
Final reduction	3.286	3.714
Gear ratio, 1st	2.462	2.750
2nd	1.556	1.786
3rd	1.190	1.350
4th	0.957	1.091
5th	0.840	0.913
Drive chain	520 HO 112 links	428 HO 136 links

1-9 GENERAL INFORMATION

CHASSIS

	<i>Comet 250</i>	<i>Comet 125</i>
Front suspension	Telescopic type	←
Rear suspension	Swingarm type	←
Steering angle	33 ° (right & left)	←
Caster	25.5 °	←
Trail	85 mm (3.35 in)	76 mm (2.29 in)
Front brake	Disk brake	←
Rear brake	Disk brake	←
Front tire size	110/70 - 17 54H	←
Rear tire size	150/70 - 17 69H	←
Front fork stroke	120 mm (4.72 in)	←

ELECTRICAL

	<i>Comet 250</i>	<i>Comet 125</i>
Ignition type	“CDI” type	←
Ignition timing	13 ° B.T.D.C.at 2,000 rpm and 30 ° B.T.D.C.at 6,000 rpm	←
Spark plug	CR8E	←
Battery	12V 12Ah	←
Fuse	15 A	←
Head lamp	HI : 60 W	HI : 35 W
	LO : 55 W	LO : 35 W
Turn signal lamp	10 W	←
Brake / Tail lamp	21 / 5 W	←
Speedometer lamp	1.7 W × 3	←
High beam indicator lamp	1.7 W	←
Turn signal indicator lamp(right & left)	1.7 W × 2	←
License plate lamp	5 W	←
Neutral indicator lamp	1.7 W	←

CAPACITIES

	<i>Comet 250</i>	<i>Comet 125</i>
Fuel tank	17.0 l	←
Engine oil, oil change	1,450 ml	←
with filter change	1,500 ml	←
overhaul	1,800 ml	1,650 ml
Front fork oil (One side)	400 ± 2.5 cc	262 cc

NOTE

The specifications are subject to change without notice.

PERIODIC MAINTENANCE

CONTENTS

PERIODIC MAINTENANCE SCHEDULE	2- 1
PERIODIC MAINTENANCE CHART	2- 1
LUBRICATION POINTS	2- 2
MAINTENANCE PROCEDURES	2- 3
VALVE CLEARANCE	2- 3
SPARK PLUG	2- 5
EXHAUST PIPE NUTS AND MUFFLER MOUNTING BOLTS	2- 5
AIR CLEANER	2- 6
CARBURETOR	2- 7
FUEL HOSE	2- 8
CLUTCH	2- 8
ENGINE OIL	2- 9
ENGINE OIL FILTER	2-10
DRIVE CHAIN	2-11
BRAKE SYSTEM	2-13
STEERING	2-17
FRONT FORK	2-17
REAR SUSPENSION	2-17
TIRE	2-18
CHASSIS BOLTS AND NUTS	2-18
COMPRESSION PRESSURE	2-19
OIL PRESSURE	2-20

2-1 PERIODIC MAINTENANCE

PERIODIC MAINTENANCE SCHEDULE

The chart below lists the recommended intervals for all the required periodic service work necessary to keep the motorcycle operating at peak performance and economy.

CAUTION

More frequent servicing should be performed on motorcycles that are used under severe conditions.

PERIODIC MAINTENANCE CHART

⊙ ENGINE

Item	Interval	Initial 1,000 km	Every 4,000 km	Every 8,000 km	page
Air cleaner element		Clean every 3,000 km · Replace every 12,000 km			2- 6
Exhaust pipe nuts and muffler mounting bolts		Tighten	Tighten	—	2-5
Valve clearance adjust		Inspect	Inspect	—	2- 3
Cylinder head nut		Tighten	Tighten		3-48
Cylinder head & Cylinder		—	—	Remove carbon	3-22
Spark plug		Clean	Clean	Replace	2- 5
Fuel hose		Inspect	Inspect	—	2- 8
		Replace every 4 years			
Engine oil filter		Replace	Replace	—	2-10
Engine oil		Replace	Replace	—	2- 9
Throttle cable		Inspect	Inspect	—	2- 7
Idle speed		Inspect	Inspect	—	2- 7
Clutch		Inspect	Inspect	—	2- 8

⊙ CHASSIS

Item	Interval	Initial 1,000 km	Every 4,000 km	Every 8,000 km	page
Drive chain		Clean and lubricate every 1,000km			2-11
Brake		Inspect	Inspect	—	2-13
Brake hose		Inspect	Inspect	—	2-13
		Replace every 4 years			
Brake fluid		Inspect	Inspect	—	2-13
		Replace every 2 years			
Tires		Inspect	Inspect	—	2-18
Steering		Inspect	Inspect	—	2-17
Front forks		—	Inspect	—	2-17
Rear suspension		—	Inspect	—	2-17
Chassis bolts and nuts		Tighten	Tighten	—	2-18

CAUTION

Using poor quality replacement parts can cause your motorcycle to wear more quickly and shorten its useful life. Use only genuine Hyoung replacement parts or their equivalent.

LUBRICATION POINT

Proper lubrication is important for smooth operation and long life of each working part of the motorcycle. Major lubrication points are indicated below.

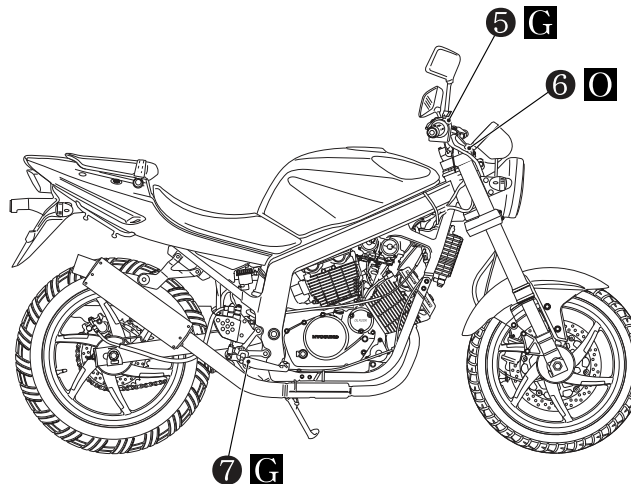
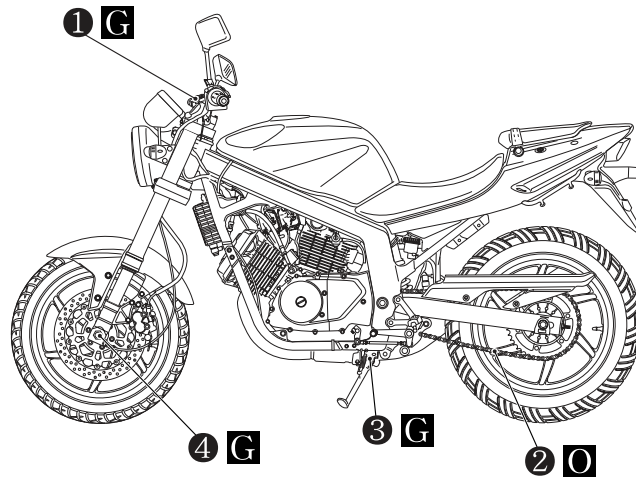

① Clutch lever holder

② Drive chain

③ Side stand pivot and spring hook

④ Speedometer gear box

⑤ Front brake lever holder

⑥ Throttle cable

⑦ Rear brake pedal pivot

○ - Motor oil, □ - Grease

NOTE

- ❖ Before lubricating each part, clean off any rusty spots and wipe off any grease, oil, dirt or grime.
- ❖ Lubricate exposed parts which are subject to rust, with either motor oil or grease whenever the motorcycle has been operated under wet or rainy condition.

MAINTENANCE PROCEDURE

This section describes the service procedure for each section of the periodic maintenance.

VALVE CLEARANCE

Inspect Interval

Inspect Initial 1,000 km and Every 4,000 km.

CAUTION

The clearance specification is for COLD state.

The valve clearance specification is different for intake and exhaust valves.

Valve clearance adjustment must be checked and adjusted, 1) at the time of periodic inspection, 2) when the valve mechanism is serviced, and 3) when the camshaft is disturbed by removing it for servicing.

- Remove the spark plug. (Refer to page 2-5)
- Remove the fuel tank. (Refer to page 4-1)
- Remove the cylinder head cover ① and ②.
- Remove the magneto cover plug ③ and the timing inspection plug ④.

- Rotate the magneto rotor to set the front cylinder's piston at TDC (Top Dead Center) of the compression stroke.
(Rotate the rotor until "F" line on the rotor is aligned with the center of hole on the crankcase.)

- To inspect the front cylinder's valve clearance, insert the thickness gauge to the clearance between the camshaft and the tappet.

Valve clearance (when cold)	
IN.	0.1 ~ 0.2 mm (0.004~0.008 in)
EX.	0.2 ~ 0.3 mm (0.008~0.012 in)

 Thickness gauge : 09900-20806

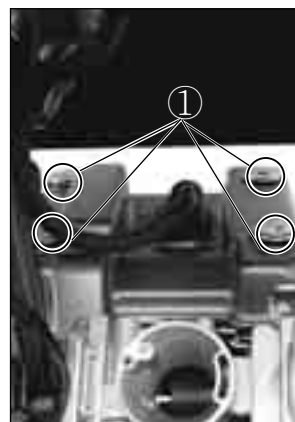

[FRONT CYLINDER]

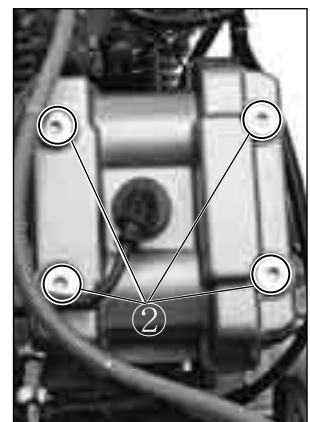

[REAR CYLINDER]

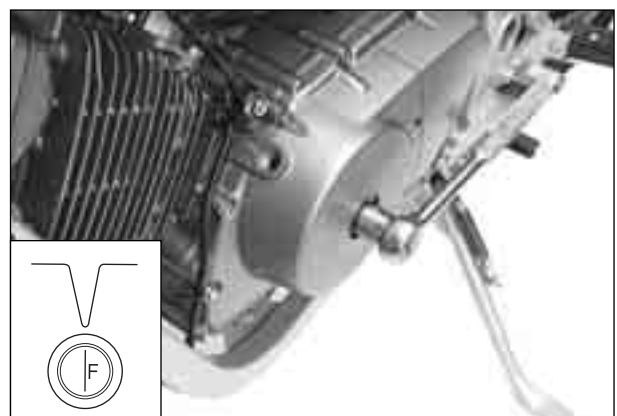
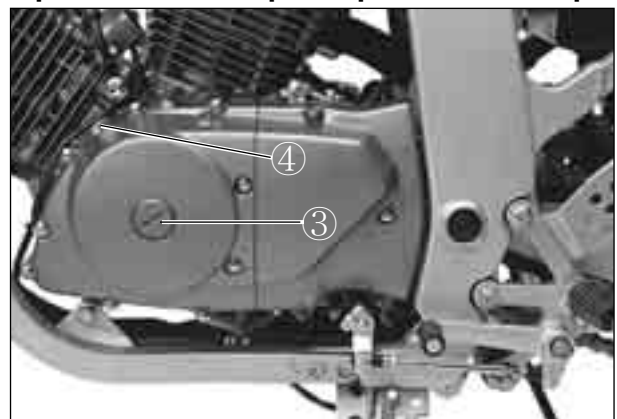

- If the clearance is out of specification, first remove the cam chain tensioner, camshaft housing, camshaft.
To install the tappet shim at original position, record the shim NO. and clearance with “A”, “B”, “C”, “D” mark on the cylinder head as the illustration.

Select the tappet that agree with tappet clearance (vertical line) and shim NO.(horizontal line) as refer to the tappet shim selection chart. (Refer to page 7-33 · 34)

Adjust valve timing, install the camshaft housing and the tensioner.

After the crankshaft rotate about 10 times, measure the valve clearance.

If the clearance be not agree, adjust the standard clearance as the same manner above.

- In case that valve adjustment which there is no the tappet shim selection chart, please follow instructions of example in the below.

For example, the intake clearance is 0.4 and the shim is 170 (1.70 mm), select 195 (1.95 mm) of the shim which 170 (1.70 mm) of the shim add up the excess clearance 0.25 mm when adjust with the standard 0.15 as the intake standard clearance 0.1~0.2 mm.

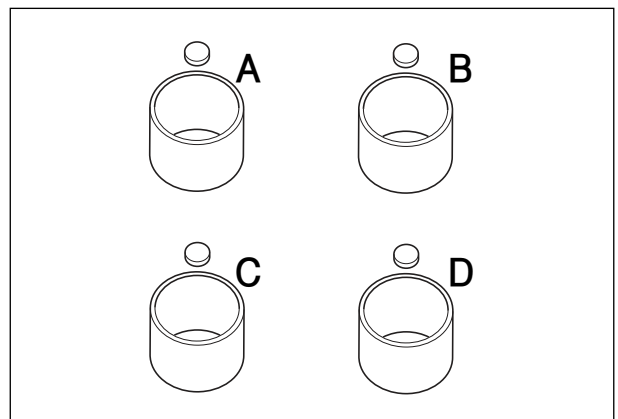
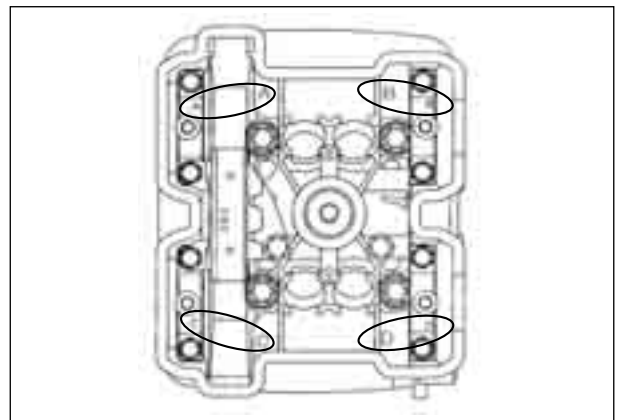
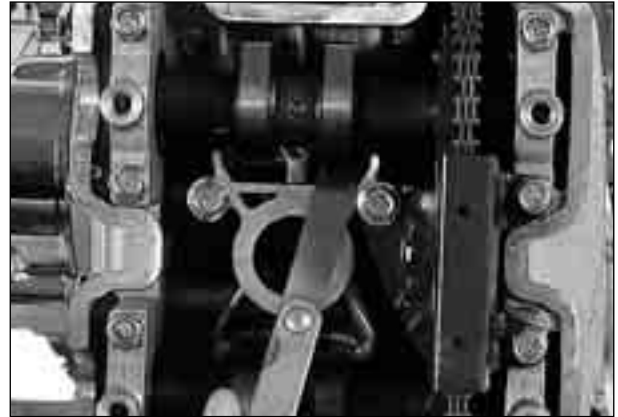

 CAUTION
<ul style="list-style-type: none"> ❖ Valve clearance should be checked when the engine is cold. ❖ If you don't rotate the crankshaft about 10 times before measuring the valve clearance, there is no meaning of valve clearance.

- Rotate the magneto rotor to set the rear cylinder's piston at TDC(Top Dead Center) of the compression stroke.
(Rotate the rotor 285° counter-clockwise from the “|F” line, and until the “|R” line on the rotor is aligned with the center of hole on the crankcase.)

- Inspect the rear cylinder's valve clearance with the same manner of the front cylinder.

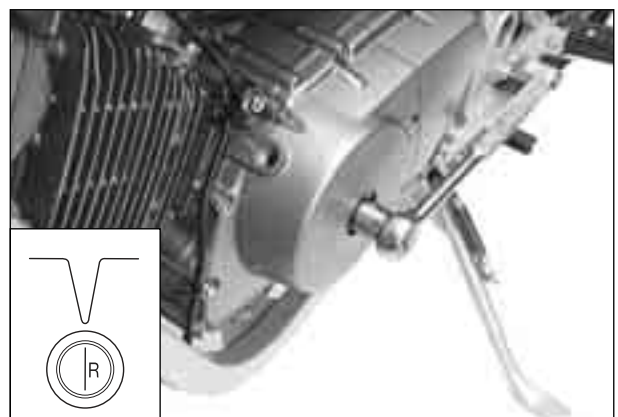

SPARK PLUG

Inspect Interval

*Clean Initial 1,000 km and Every 4,000 km,
Replace Every 8,000 km.*

- Disconnect the spark plug caps.
- Remove the spark plugs.

TYPE	SPARK PLUG SPECIFICATION
Hot type	CR7E
Standard type	CR8E
Cold type	CR9E

Remove the carbon deposite with wire or pin and adjust the spark plug gap to 0.7~0.8 mm, measuring with a thickness gauge.

Spark plug gap	0.7~0.8 mm (0.028~0.032 in)
-----------------------	-----------------------------

 **Thickness gauge : 09900-20806**

Check to see the worn or burnt condition of the electrodes.

If it is extremely worn or burnt, replace the plug. And also replace the plug if it has a broken insulator, damaged thread, etc.

- Install the spark plug, and then tighten it to specified torque.

 **Spark plug : 20~25 N · m (2.0~2.5 kg · m)**

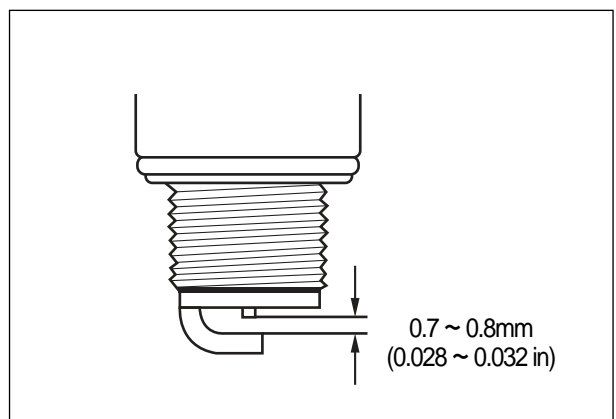
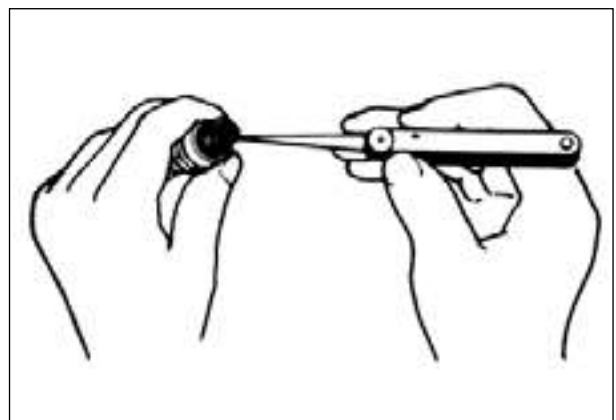
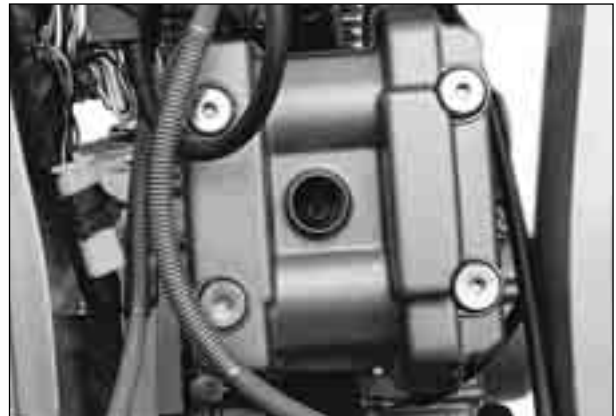

EXHAUSE PIPE NUTS AND MUFFLER MOUNTING BOLTS

Inspect Interval

Tighten Initial 1,000 km and Every 4,000 km.

- Tighten the exhaust pipe nuts ①, and muffler mounting bolts ② to the specified torque.

 **Exhaust pipe nut**
: 18~28 N · m (1.8~2.8 kg · m)

Muffler mounting bolt
: 20~30 N · m (2.0~3.0 kg · m)

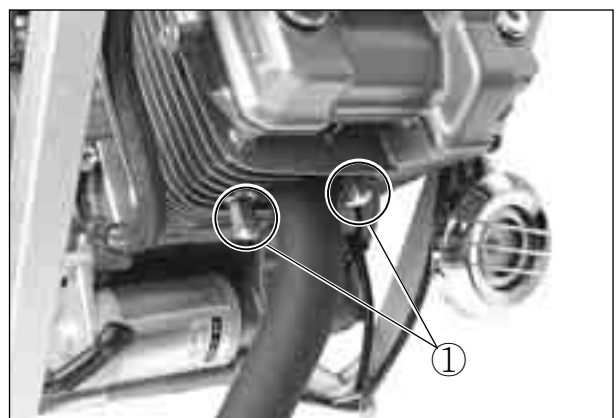

[Front Cylinder]



[Rear Cylinder]

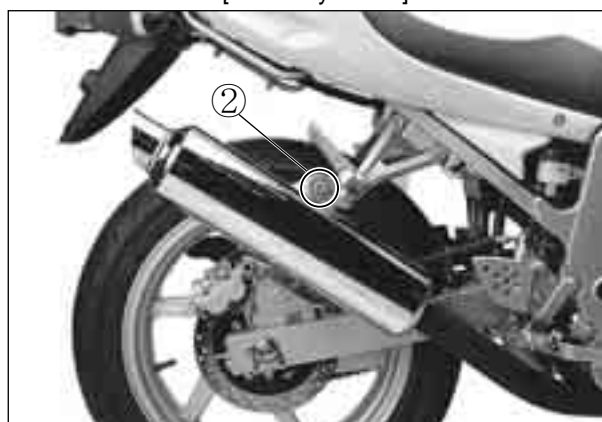
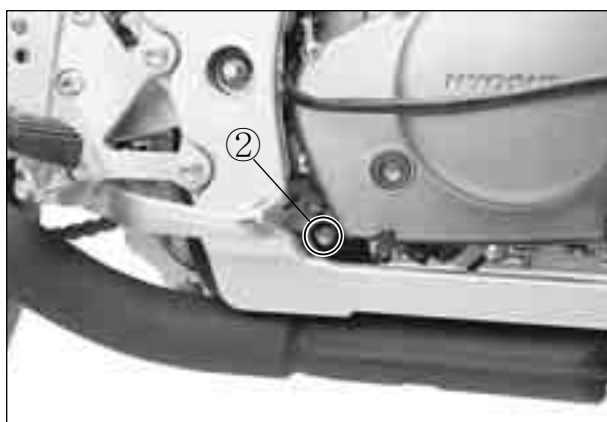

AIR CLEANER

Inspect Interval

*Clean Every 3,000 km,
Replace Every 12,000 km.*

- The air cleaner is located under the fuel tank.
Remove the fuel tank.
- Remove the four screw ③.
- Pull up the air cleaner cover and the air cleaner element ④.

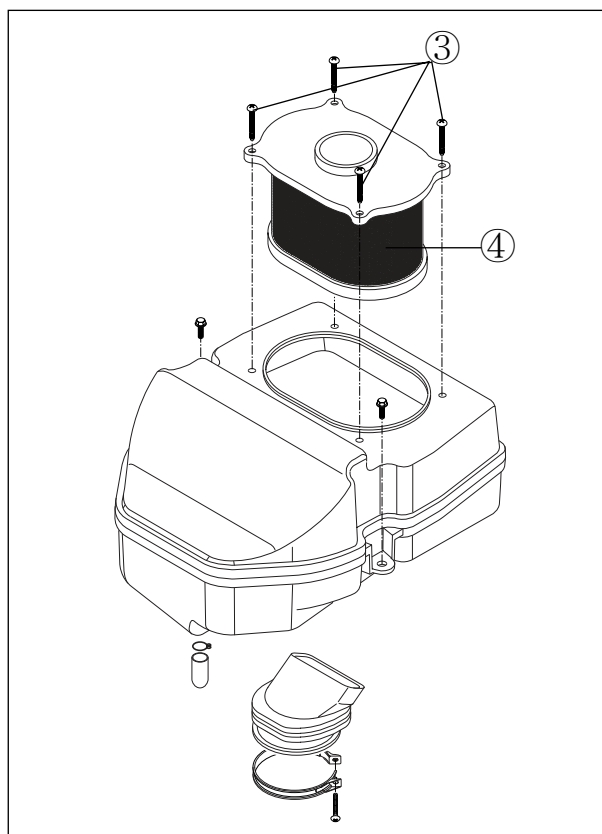

2-7 PERIODIC MAINTENANCE

Clean the air cleaner element for the following:

- When the air cleaner element clean with the air gun, necessarily blow at the inside by compressed air.
- Carefully examine the air cleaner element for tears during cleaning. Replace it with a new one if it is torn.
- Assemble the element completely or damage severely the engine.
- Be careful not to allow water to go inside the air cleaner element.

CARBURETOR

Inspect Interval

Inspect Initial 1,000 km and Every 4,000 km.

⊙ IDLE SPEED

⚠ CAUTION

Make this inspection when the engine is hot.

- Connect an engine tachometer to the high tension cord.

Start up the engine and set its speed at anywhere 1,450 and 1,550 rpm by turning throttle stop screw ①.

Engine idle speed	1,450 ~ 1,550 rpm
--------------------------	-------------------

 **Engine tachometer : 09900-26006**

⊙ THROTTLE CABLE PLAY

There should be 0.5~1.0 mm play on the throttle cable. To adjust the throttle cable play.

- Tug on the throttle cable to check the amount of play.
- Loosen the lock nut ② and turn the adjuster ③ in or out until the specified play is obtained.
- Secure the lock nuts while holding the adjuster in place.

Throttle cable play ④	0.5~1.0 mm (0.02~0.04 in)
------------------------------	---------------------------

⚠ CAUTION

More frequent servicing may be performed on motorcycles that are used under severe conditions, also clean the air cleaner element when replacing the oil to prevent damage of the engine.

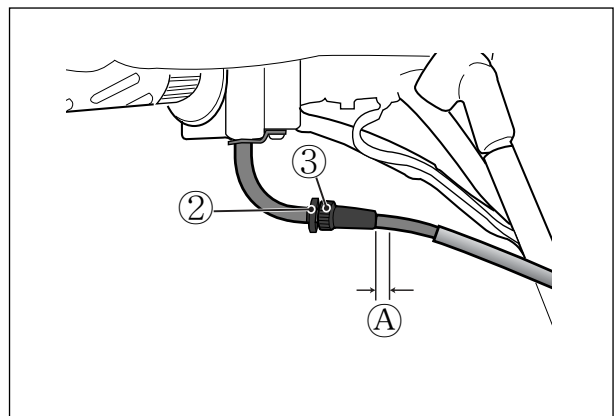
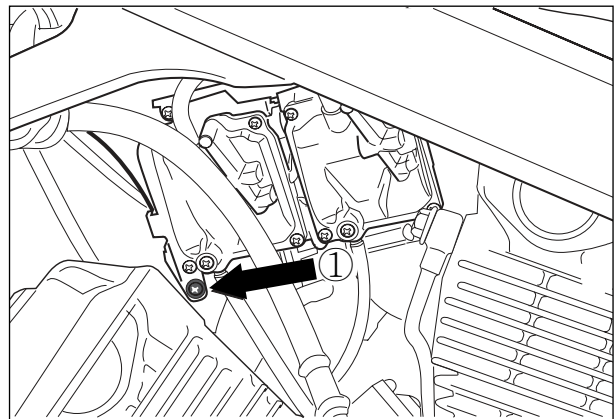

FUEL HOSE

Inspect Interval

*Inspect Initial 1,000 km and Every 4,000 km,
Replace every 4 years.*

- Remove the front and rear seat. (Refer to page 6-1)
Inspect the fuel hoses for damage and fuel leakage. If any defects are found, the fuel hoses must be replaced.



[『 Comet 250 』]

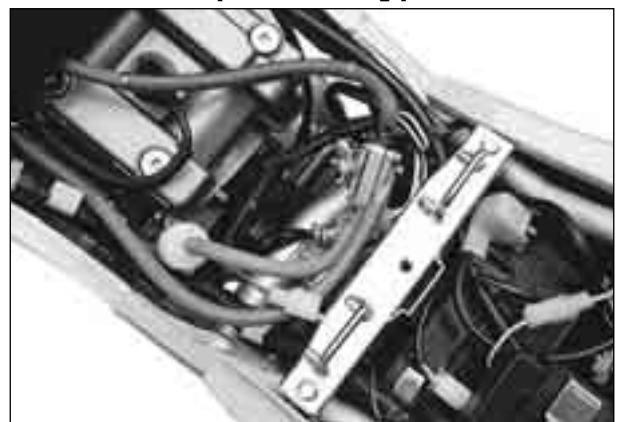

[『 Comet 125 』]

CLUTCH

Inspect Interval

Inspect Initial 1,000 km and Every 4,000 km.

Clutch play should be 4 mm as measured at the clutch lever holder before the clutch begins to disengage. If the play in the clutch is incorrect, adjust it in the following way :

- Loosen the lock nut ① and screw the adjuster ② on the clutch lever holder all the way in.
- Loosen clutch cable adjuster lock nut ③.
- Turn the clutch cable adjuster ④ in or out to acquire the specified play.
- Tighten lock nut while holding the adjuster in position.
- The clutch cable should be lubricated with a light weight oil whenever it is adjusted.

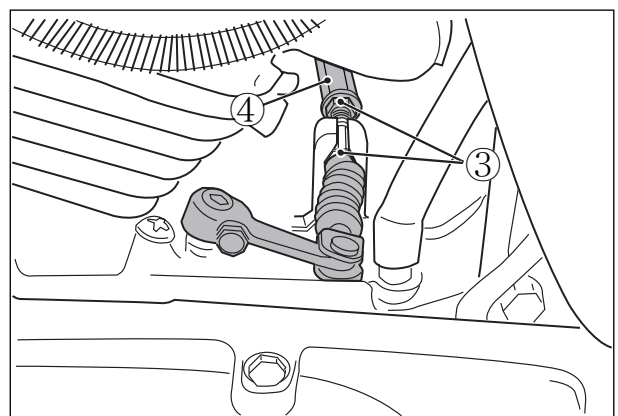
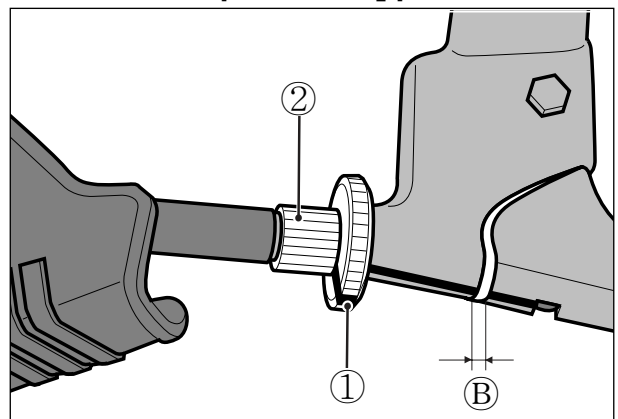

Clutch cable play ⑧

4 mm (0.16 in)

2-9 PERIODIC MAINTENANCE

⊕ GEARSHIFT LEVER HEIGHT ADJUSTMENT

- Loosen the lock nut ①.
- With the link rod ② turned, adjust the gearshift lever height.

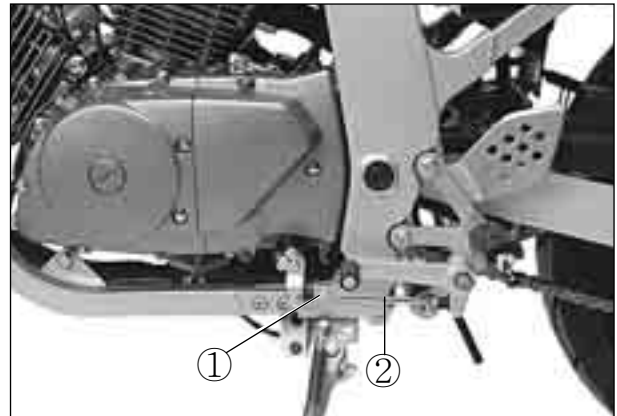

ENGINE OIL

Inspect Interval

Replace Initial 1,000 km and Every 4,000 km.

Necessary amount of engine oil		
	『Comet 250』	『Comet 125』
Oil change	1,450 ml	1,450 ml
Filter change	1,500 ml	1,500 ml
Overhaul engine	1,800 ml	1,650 ml
Engine oil type	SAE 10W/30 or 10W/40 API Over SG	

Oil should be changed while the engine is warm. Oil filter replacement at the above intervals, should be together with the engine oil change.

- Keep the motorcycle upright.
- Place an oil pan below the engine, and drain the oil by removing the filler cap ③ and drain plug ④.
- Tighten the drain plug ④ to the specified torque, and pour fresh oil through the oil filler. Use an API classification of Over SG oil with SAE 10W/30 or 10W/40 viscosity.

🔧 Oil drain plug : 18-20 N · m (1.8-2.0 kg · m)

- Start up the engine and allow it to run for several minutes at idling speed.
- Turn off the engine and wait about three minutes, then check the oil level through the inspection window. If the level is below mark “F”, add oil to “F” level. If the level is above mark “F”, drain oil to “F” level.

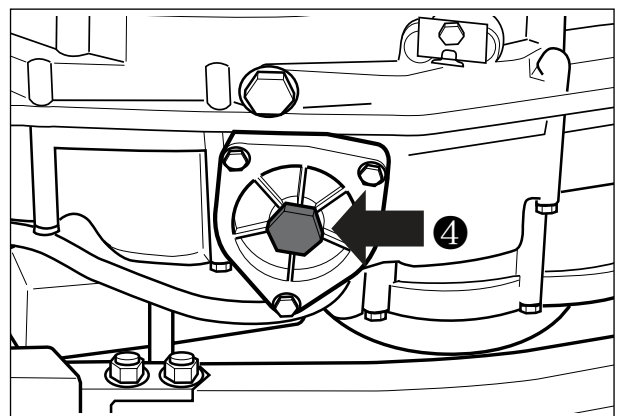
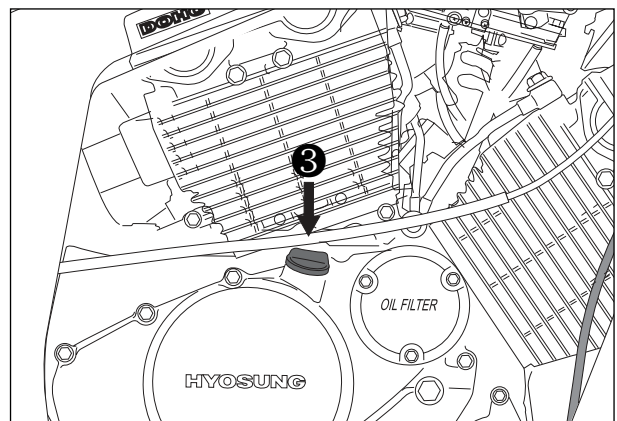

⚠ CAUTION

Never operate the motorcycle if the engine oil level is below the “Lower line mark(L)” in the inspection window. Never fill the engine oil above the “Upper line mark(F)”.

Engine oil level being most suitable about 1mm under the “Upper line mark(F)” of the engine oil lens. In case of the engine oil pouring in excessively, the engine output being made insufficient.

Be careful not to pouring in the engine oil excessively.

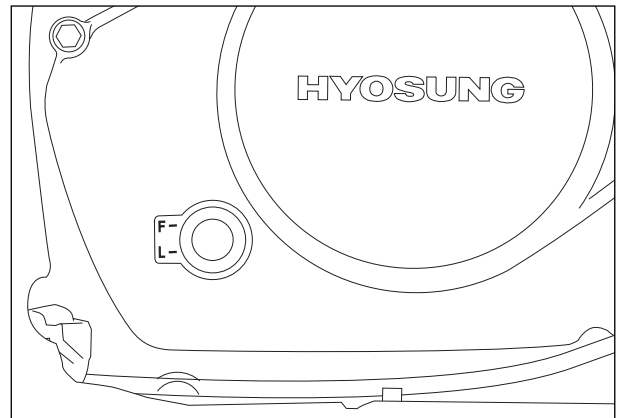

⚠ CAUTION

Necessarily, confirm and clean the oil strainer ① when replace the engine oil (specially, when first replacement).

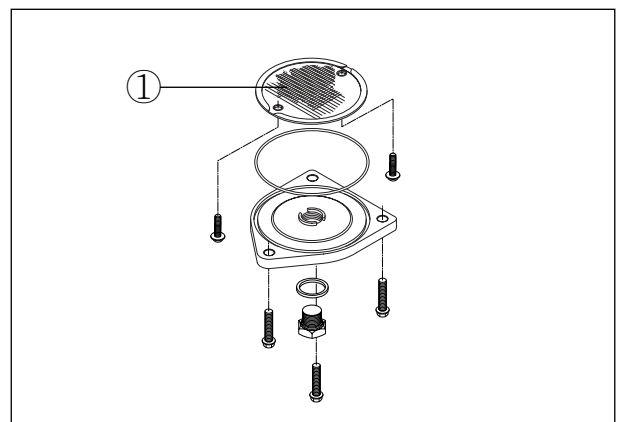

⚠ CAUTION

More frequent servicing may be performed on motorcycles that are used under severe conditions.

ENGINE OIL FILTER

Inspect Interval

Replace Initial 1,000 km and Every 4,000 km.

- Drain the engine oil as described in the engine oil replacement procedure.
- Remove the oil filter cap ②.
- Remove the oil filter.
- Install the new O-ring ③.

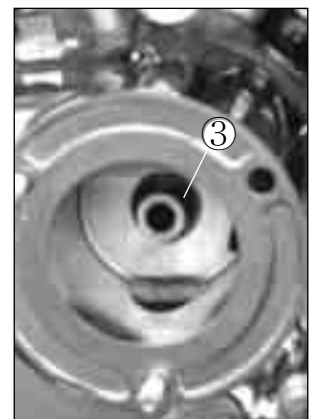
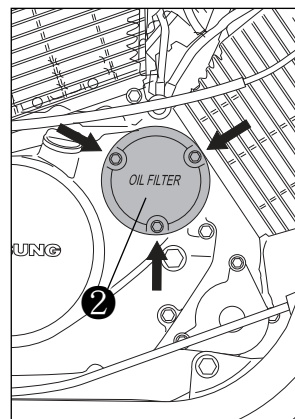

- Install the new oil filter.
- Install the new O-ring ④ and spring ⑤ to the oil filter cap.
- Install the oil filter cap.

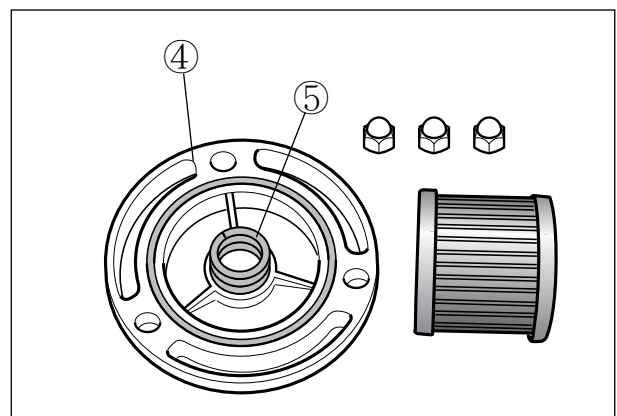

⚠ CAUTION

Before installing the oil filter cap, apply engine oil lightly to the new O-ring ④.

⦿ OIL FILTER INSTALLATION

⚠ CAUTION

When install the oil filter, necessarily, “HYOSUNG” character and “16510H05240” part’s NO. install toward the outside, otherwise can damage the engine.

⚠ WARNING

Engine oil and exhaust pipes can be hot enough to burn you.
Wait until the oil drain plug and exhaust pipes are cool enough to touch with bare hands before draining oil.

- Add new engine oil and check the oil level as described in the engine oil replacement procedure.

⚠ CAUTION

Use HYOSUNG MOTORCYCLE GENUINE OIL FILTER only, since the other make’s genuine filters and after-market parts may differ filtering performance and durability, which could cause engine damage or oil leaks. Hyosung motors genuine oil filter is also not usable for the motorcycles.

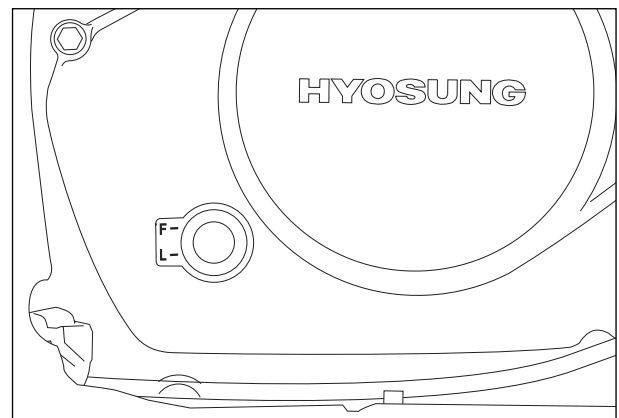
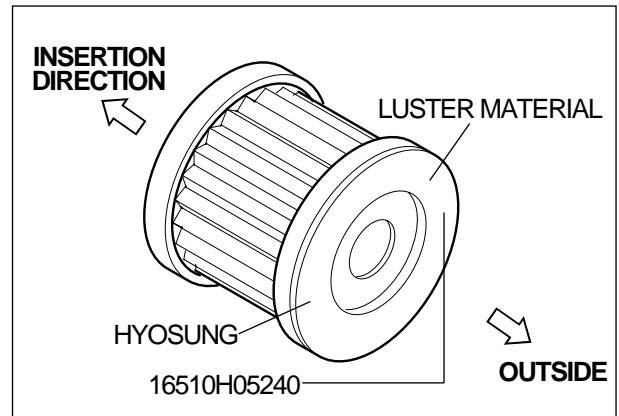

DRIVE CHAIN

Inspect Interval

Clean and Lubricate Every 1,000 km.

Visually check the drive chain for the possible defects listed below. (Support the motorcycle by the jack or block, turn the rear wheel slowly by hand with the transmission shifted to Neutral.)

- Loose pins
- Excessive wear
- Damaged rollers
- Improper chain adjustment
- Dry or rusted links
- Kinked or binding links

If any defects are found, the drive chain must be replaced.

NOTE

When replacing the drive chain, replace the drive chain and sprocket as a set.

- Loose the axle nut ①.

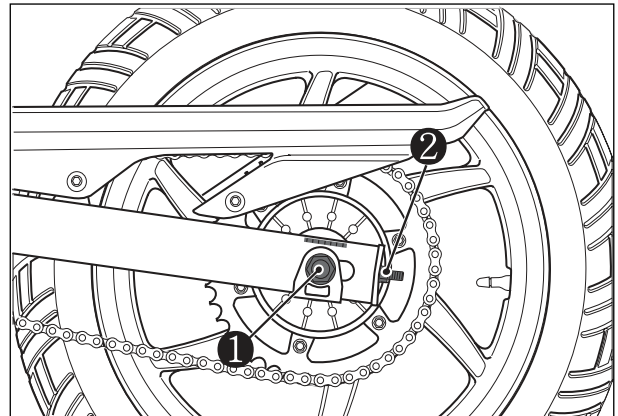

- Tense the drive chain fully by turning both chain adjusters ②, ③.

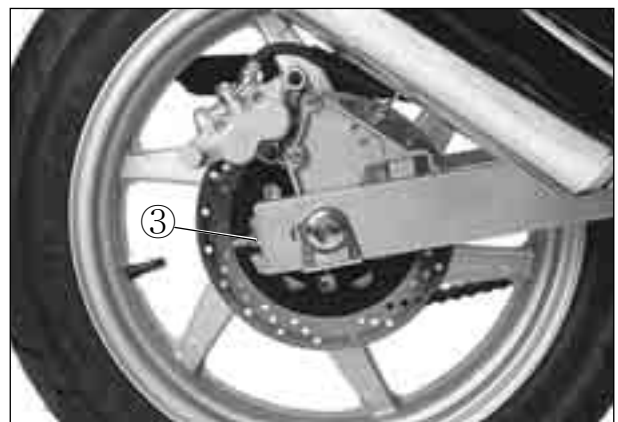

- Count out 21 pins (20 pitches) on the chain and measure the distance between the two points. If the distance exceeds the service limit, the chain must be replaced.

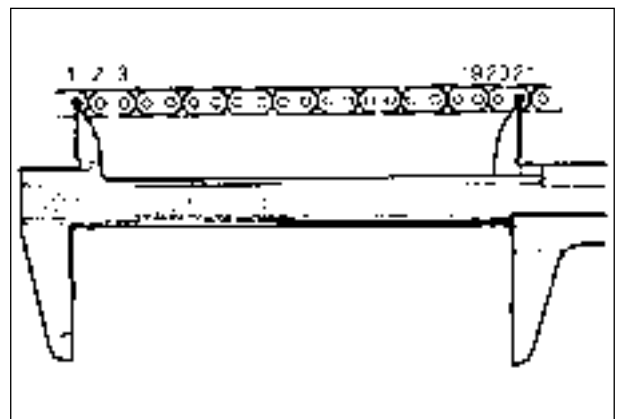

Drive chain 20pitch length	Service limit	
	『Comet-250』	『Comet-125』
	319.4 mm (12.58 in)	256.5 mm (10.10 in)

- Loosen or tighten both chain adjusters ①, ② until the chain has 20 ~ 30 mm of slack in the middle between the engine and rear sprockets. The marks ③, ④ on both chain adjusters must be at the same position on the scale to ensure that the front and rear wheels are correctly aligned.

Drive chain slack	20 ~ 30 mm (0.79 ~ 1.18 in)
--------------------------	-----------------------------



2-13 PERIODIC MAINTENANCE

- Place the motorcycle on jack or block for accurate adjustment.
- After adjusting the drive chain, tighten the axle nut to the specified torque.
- Tighten both chain adjusters (A), (B) securely.
🔧 Rear axle nut : 90~140 N · m (9.0~14.0 kg · m)

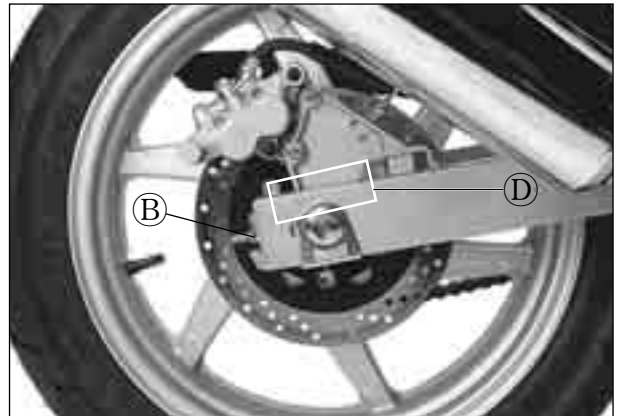

- Recheck the drive chain slack after tightening the axle nut.

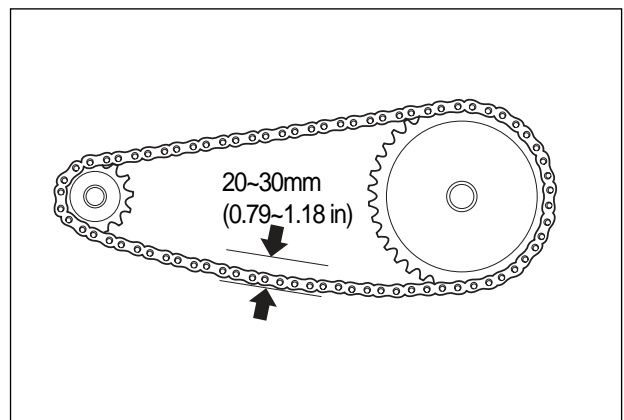

- Wash the drive chain with kerosine. If the drive chain tends to rust quickly, the intervals must be shortened.
- After washing and drying the chain, oil it with a engine oil or chain lubricating oil.

⚠ CAUTION

The drive chain for this motorcycle is made of the special material.

The chain should be replaced with a 520HO for 『Comet 250』 and 428SO for 『Comet 125』.

Use of another chain may lead to premature chain failure.

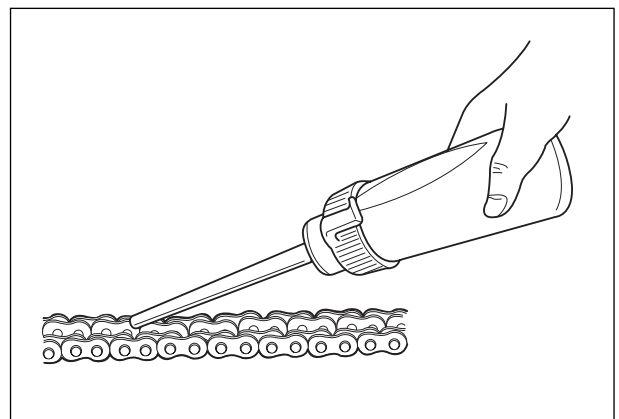

BRAKE SYSTEM

Inspect Interval

[BRAKE]

Inspect Initial 1,000 km and Every 4,000 km.

[BRAKE HOSE & BRAKE FLUID]

Inspect Initial 1,000 km and Every 4,000 km.

Replace the brake hoses Every 4 years,

Replace the brake fluid Every 2 years.

⊙ **BRAKE FLUID LEVEL CHECK**

- Keep the motorcycle upright and place the handlebars straight.
- Check the brake fluid level by observing the lower limit line (LOWER) on the front brake fluid reservoir.
- When the level is below the lower limit line (LOWER), replenish with brake fluid that meets the following specification.

 **Specification and Classification : DOT 3 or DOT 4**

 **CAUTION**

The brake system of this motorcycle is filled with a glycol-based brake fluid. Do not use or mix different types of fluid such as silicone-based or petroleum-based. Do not use any brake fluid taken from old, used or unsealed containers. Never re-use brake fluid left over from the last servicing or stored for a long period.

 **CAUTION**

Brake fluid, if it leaks, will interfere with safe running and immediately discolor painted surfaces. Check the brake hoses and hose joints for cracks and oil leakage before riding.

⊙ **BRAKE PAD WEAR**

The extend of brake pad wear can be checked by observing the grooved limit  on the pad. When the wear exceeds the grooved limit, replace the pads with new ones.

 **CAUTION**

Replace the brake pad as a set, otherwise braking performance will be adversely affected.

⊙ **FRONT AND REAR BRAKE PAD REPLACEMENT**

- Remove the brake caliper.
- Remove the brake pads.
- To reassemble, reverse the above sequence.

 **Front brake caliper mounting bolt**
: 18~28 N · m (1.8~2.8 kg · m)
Rear brake caliper mounting bolt
: 18~28 N · m (1.8~2.8 kg · m)

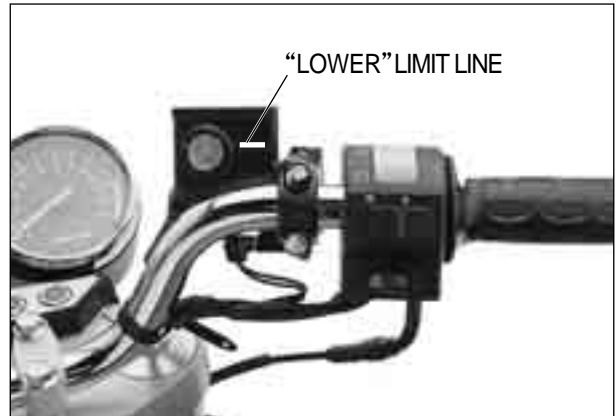

[Front Brake]



[Rear Brake]

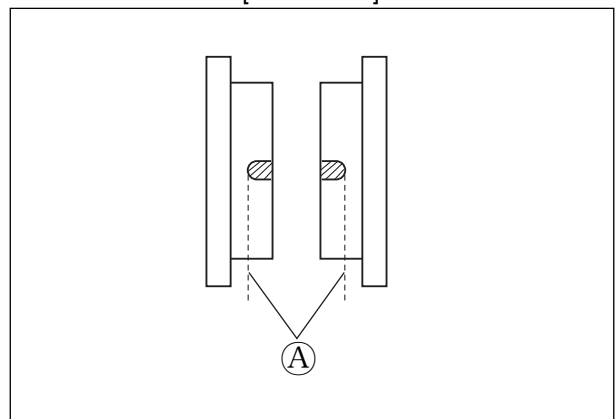

[Front Brake]

2-15 PERIODIC MAINTENANCE

⊙ FRONT AND REAR BRAKE FLUID REPLACEMENT

- Place the motorcycle on a level surface and keep the handlebars straight.
- Remove the master cylinder reservoir cap and diaphragm.
- Suck up the old brake fluid as much as possible.
- Fill the reservoir with new brake fluid.



Specification and Classification

: DOT 3 or DOT 4

- Connect a clear hose ① to the air bleeder valve and insert the other end of the hose into a receptacle.

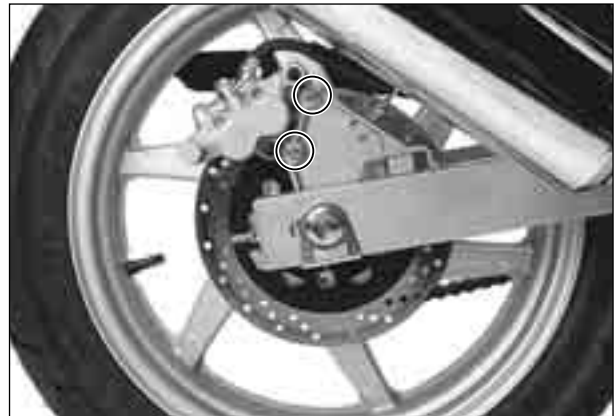

[Rear Brake]



- Loosen the air bleeder valve and pump the brake lever until the old brake fluid is completely out of the brake system.



- Close the air bleeder valve and disconnect the clear hose. Fill the reservoir with new brake fluid to the upper line.
- Replace the rear brake's fluid with the same manner of the front brake.



Front brake caliper air bleeder valve

: 6~9 N · m (0.6~0.9 kg · m)

Rear brake caliper air bleeder valve

: 6~9 N · m (0.6~0.9 kg · m)



⦿ AIR BLEEDING OF THE BRAKE FLUID CIRCUIT

Air trapped in the brake fluid circuit acts like a cushion to absorb a large proportion of the pressure developed by the master cylinder and thus interferes with the full braking performance of the brake caliper. The presence of air is indicated by “sponginess” of the brake lever and also by lack of braking force. Considering the danger to which such trapped air exposes the machine and rider, it is essential that, after remounting the brake and restoring the brake system to the normal condition, the brake fluid circuit be purged of air in the following manner :

- Fill the master cylinder reservoir to top of the inspection window. Replace the reservoir cap to prevent dirt from entering it.
- Attach a hose to the air bleeder valve, and insert the free end of the hose into a receptacle.
- Bleed air from the brake system.
- Squeeze and release the brake lever several times in rapid succession and squeeze the lever fully without releasing it. Loosen the bleeder valve by turning it a quarter of a turn so that the brake fluid runs into the receptacle, this will remove the tension of the brake lever causing it to touch the handlebar grip. Then, close the air bleeder valve, pump and squeeze the brake lever, and open the valve. Repeat this process until the fluid flowing into the receptacle no longer contains air bubbles.



NOTE

While bleeding the brake system, replenish the brake fluid in the reservoir as necessary. Make sure that there is always some fluid visible in the reservoir.

- Close the air bleeder valve, and disconnect the hose. Fill the reservoir with brake fluid to the upper line.
- Bleed the rear brake's air with the same manner of front brake.

- 🔧 **Front brake caliper air bleeder valve**
: 6~9 N · m (0.6~0.9 kg · m)
- Rear brake caliper air bleeder valve**
: 6~9 N · m (0.6~0.9 kg · m)

⚠ CAUTION

Handle brake fluid with care : the fluid reacts chemically with paint, plastics, rubber materials, etc.

2-17 PERIODIC MAINTENANCE

⊙ FRONT BRAKE LAMP SWITCH

The front brake lamp switch is located beneath the front brake lever. Loosen the switch fitting screws and adjust the timing by moving the switch body forward or backward.

⊙ REAR BRAKE LAMP SWITCH

Adjust the rear brake lamp switch so that the brake lamp will come on just before pressure is felt when the brake pedal is depressed.



STEERING

Inspect Interval

Inspect Initial 1,000 km and Every 4,000 km.

Steering should be adjusted properly for smooth turning of handlebars and safe running. Overtight steering prevents smooth turning of the handlebars and too loose steering will cause poor stability. Check that there is no play in the steering stem while grasping the lower fork tubes by supporting the machine so that the front wheel is off the ground, with the wheel straight ahead, and pull forward. If play is found, perform steering bearing adjustment as described in page 6-29 of this manual.



FRONT FORK

Inspect Interval

Inspect Every 4,000 km.

Inspect the front forks for oil leakage, scoring or scratches on the outer surface of the inner tubes. Replace any defective parts, if necessary.



REAR SUSPENSION

Inspect Interval

Inspect Every 4,000 km.

Inspect the rear shock absorber for oil leakage and mounting rubbers including engine mounting for wear and damage. Replace any defective parts, if necessary. (Refer to page 6-36)

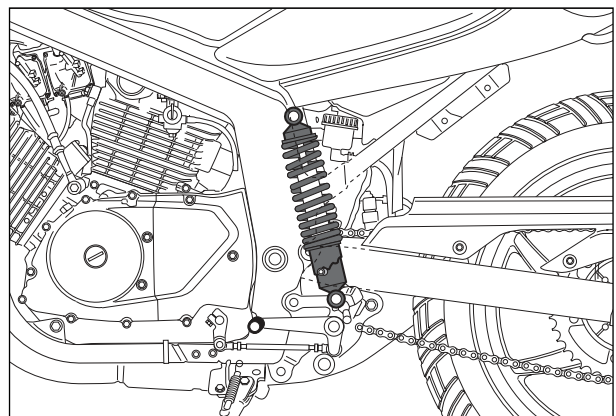

TIRE

Inspect Interval

Inspect Initial 1,000 km and Every 4,000 km.

⊙ TIRE TREAD CONDITION

Operating the motorcycle with excessively worn tires will decrease riding stability and can lead to loss of control.

- Inspect shortage of tire thread's depth by the 『tire wear indicator』.
- Replace the front and rear tires at once when appear the 『tire wear indicator』.

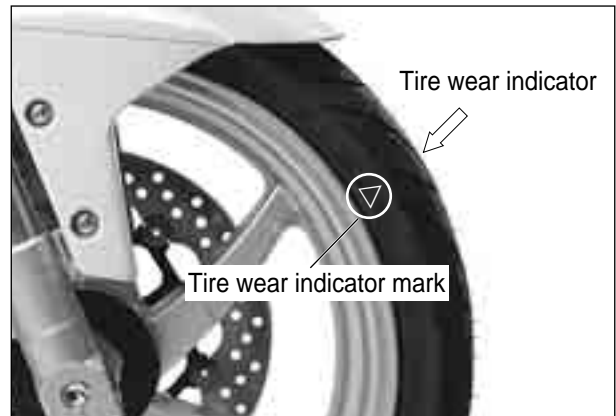

⊙ TIRE PRESSURE

If the tire pressure is too high or too low, steering will be adversely affected and tire wear increased. Therefore, maintain the correct tire pressure for good roadability or shorter tire life will result. Cold inflation tire pressure is as follows.

COLD INFLATION TIRE PRESSURE	SOLD RIDING			DUAL RIDING		
	KPa	kgf/cm ²	psi	KPa	kgf/cm ²	psi
Front	196	2.00	29.0	196	2.00	29.0
Rear	221	2.25	32.0	245	2.50	36.0

⚠ CAUTION

The standard tire on 『Comet-250』/ 『Comet-125』 is 110/70-17 54H for front and 150/70-17 69H for rear. The use of tires other than those specified may cause instability. It is highly recommended to use a HYOSUNG Genuine Tire.

CHASSIS BOLTS AND NUTS

Inspect Interval

Tighten Initial 1,000 km and Every 4,000 km.

Check that all chassis bolts and nuts are tightened to their specified torque. (Refer to page 7-12)

COMPRESSION PRESSURE

The compression of a cylinder is a good indicator of its internal condition.

The decision to overhaul the cylinder is often based on the results of a compression test. Periodic maintenance records kept at your dealership should include compression reading for each maintenance service.

『 Comet 250 』

Compression pressure	
Standard	14~16 kg/cm ² (at 500 rpm)
Service limit	12 kg/cm ² (at 500 rpm)

『 Comet 125 』

Compression pressure	
Standard	11~13 kg/cm ² (at 500 rpm)
Service limit	10 kg/cm ² (at 500 rpm)

Low compression pressure can indicate any of the following conditions :

- Excessively worn cylinder wall
- Worn-down piston or piston rings
- Piston rings stuck in grooves
- Poor seating of valves
- Ruptured or otherwise defective cylinder head gasket

◎ COMPRESSION TEST PROCEDURE

NOTE

- ❖ *Before testing the engine for compression pressure, make sure that the cylinder head bolts are tightened to the specified torque values and valves are properly adjusted.*
- ❖ *Have the engine warmed up by idling before testing.*
- ❖ *Be sure that the battery used is in fully-charged condition.*

Remove the parts concerned and test the compression pressure in the following manner.

- Loosen the oil cooler mounting bolts from the frame.
- Remove all the spark plug.
- Fit the compression gauge in one of the plug holes, while taking care that the connection is tight.
- Keep the throttle grip in full-open position.
- Crank the engine a few seconds with the starter, and record the maximum gauge reading as the compression of that cylinder.

 **Compression gauge : 09915-64510**

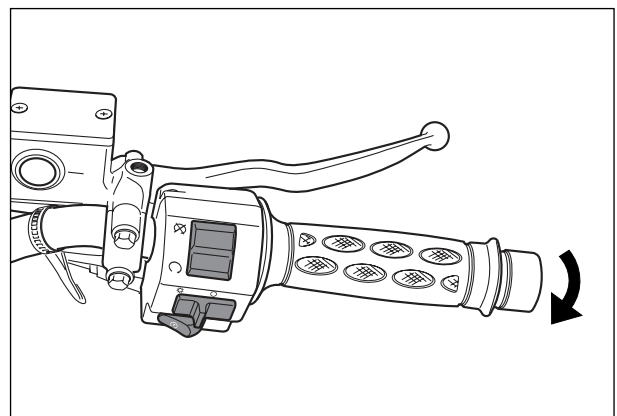

OIL PRESSURE

Check the oil pressure periodically. This will give a good indication of the condition of the moving parts.

『 Comet 250 』

Oil pressure	Standard
	2.0 ± 0.5 kg/cm ² (at 65 °C · 3,000 rpm)

『 Comet 125 』

Oil pressure	Standard
	0.9 ~1.1 kg/cm ² (at 65 °C · 3,000 rpm)

If the oil pressure is lower or higher than the specification, the following causes may be considered.

⊙ LOW OIL PRESSURE

- Oil leakage from the oil passage
- Damaged O-ring
- Defective oil pump
- Combination of above items

⊙ HIGH OIL PRESSURE

- Engine oil viscosity is too high
- Clogged oil passage
- Combination of the above items

⊙ OIL PRESSURE TEST PROCEDURE

Check the oil pressure in the following manner.

- Remove the oil check plug and install the adapter of oil pressure gauge at the removed position.
- Connect an engine tachometer.
- Warm up the engine as follows :
Summer : 10 min. at 2,000 rpm.
Winter : 20 min. at 2,000 rpm.
- After warming up, increase the engine speed to 3,000 rpm. (with the engine tachometer), and read the oil pressure gauge.

 Oil pressure gauge : 09915-74510
Engine tachometer : 09900-26006



ENGINE

CONTENTS

ENGINE REMOVAL AND REINSTALLATION	3- 1
ENGINE REMOVAL	3- 1
ENGINE REINSTALLATION	3- 5
ENGINE DISASSEMBLY	3- 7
STARTER MOTER	3- 7
CYLINDER HEAD COVER	3- 8
PISTON	3-12
MAGNETO COVER	3-13
MAGNETO ROTOR	3-13
CLUTCH COVER	3-14
CLUTCH	3-15
PRIMARY DRIVE GEAR	3-16
OIL PUMP	3-16
GEARSHIFT SHAFT	3-17
ENGINE COMPONENT INSPECTION AND SERVICE	3-19
ENGINE REASSEMBLY	3-36

CAUTION

- ❖ Mark an identification of assembly location on each removed part so that each will be restored to the original position during reassembly.
- ❖ Wash clean and dry the removed parts before inspecting and measuring.
- ❖ Oil the rotating or sliding parts before assembly.
- ❖ Make sure to use the correct type of lubricant where specified.
- ❖ Check that each rotating or sliding part moves or operates smoothly after assembly.
- ❖ Make sure to follow the bolt tightening order where specified.
- ❖ If the correct length of the bolt is confused when tightening the crankcase or cover, insert all the bolts and check that the tightening margin is equal in each bolt.

ENGINE REMOVAL AND REINSTALLATION

ENGINE REMOVAL

NOTE

If the engine is dirtied, wash the machine with a suitable cleaner before removing the engine.

- Remove the front seat. (Refer to page 6-1)
- Remove the fuel tank. (Refer to page 4-1)
- Drain the engine oil. (Refer to page 2-9)
- Disconnect the battery ⊖ lead wire ①.

⚠ CAUTION

First, disconnect the ⊖ lead wire ①.

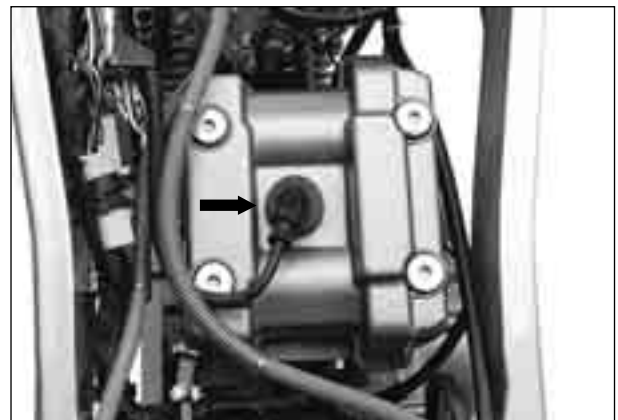
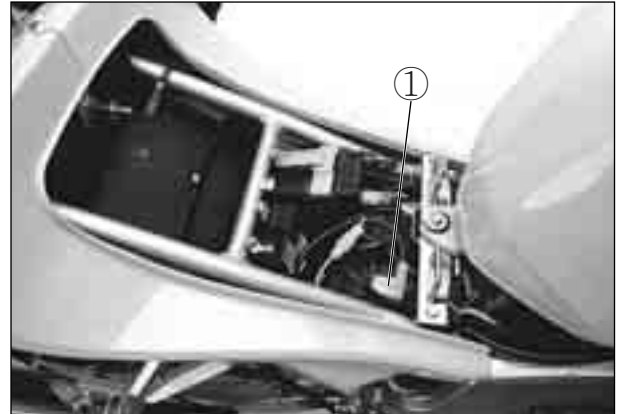

⊙ AIR CLEANER

- With the two screws loosened, remove the air cleaner case.
- Loosen the clamp screw.



⊙ CARBURETOR

- Remove the carburetor after removed the intake pipes. (Refer to page 4-5)
- Disconnect the vacuum hoses ②. (『Comet 125』)



⊙ CLUTCH CABLE

- Disconnect the clutch cable end out of clutch lever.
- Disconnect the clutch cable end out of clutch release arm.

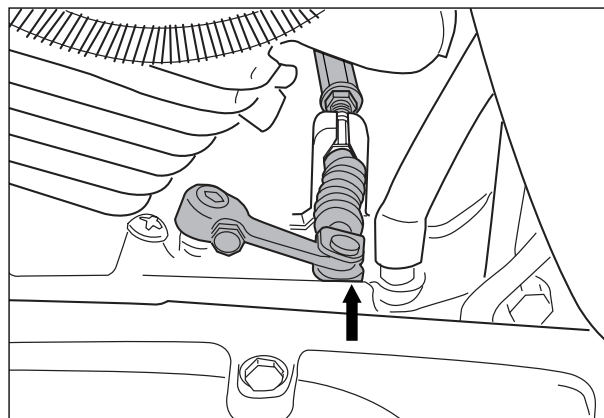
**⊙ EXHAUST PIPE AND MUFFLER**

- With the exhaust pipe bolts and muffler mounting bolts removed, remove the exhaust pipes and mufflers.



[Front Cylinder]

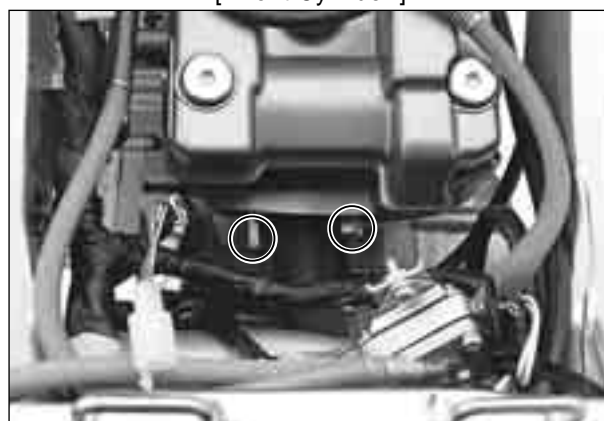

[Rear Cylinder]

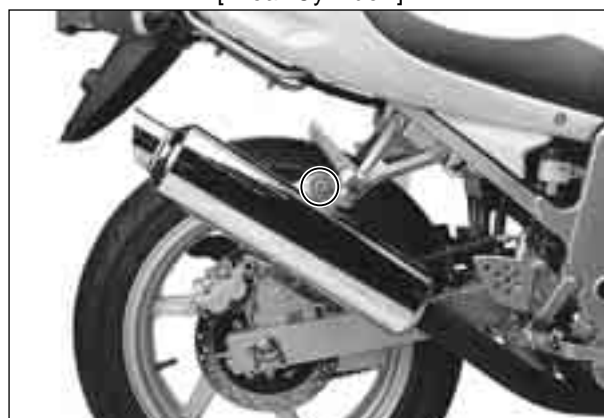

3-3 ENGINE

⦿ ELECTRIC PARTS

- With take out the spark plug caps, remove the spark plug.



[Front Cylinder]

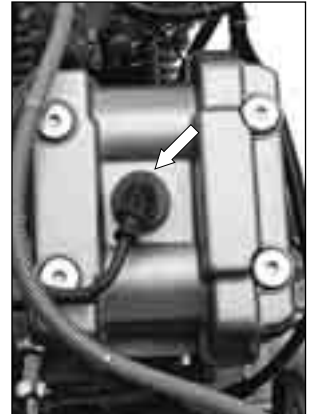

[Rear Cylinder]

- Remove the starter motor lead wire.

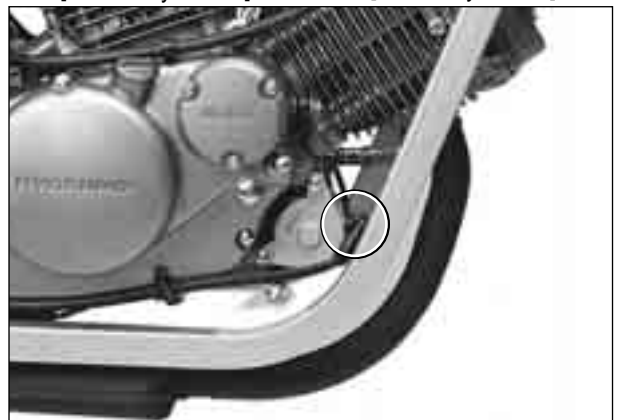

- Remove the engine ground lead wire ①.

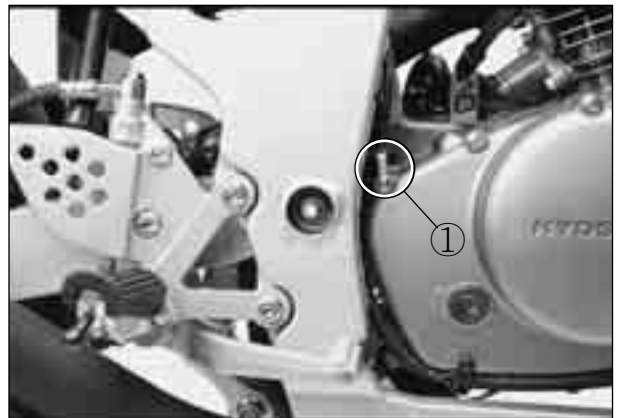

- Disconnect the magneto coupler ②.

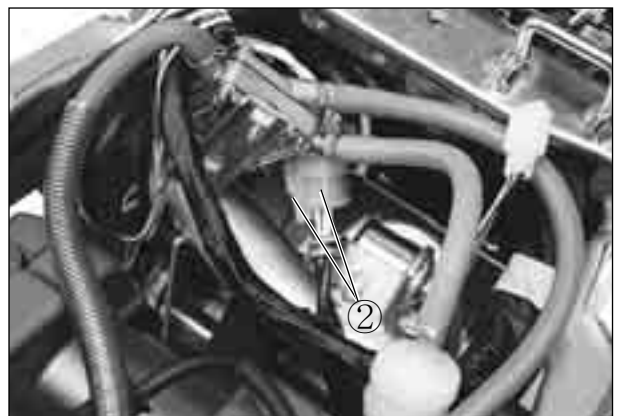

⊕ ENGINE SPROCKET

- Remove the engine sprocket cover.

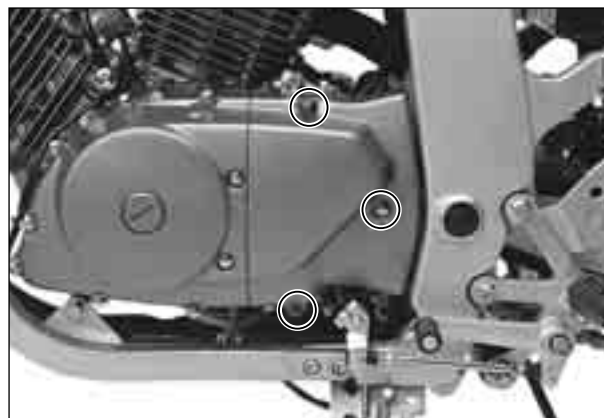

- Remove the breather hose.

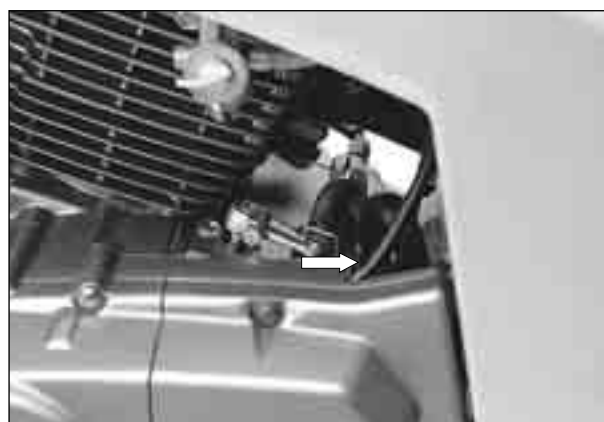

- Loosen the bolt and remove the link rod.
- Flatten the lock washer.
- Remove the engine sprocket nut ① and washer.

NOTE

When loosening the engine sprocket nut, depress the brake pedal.

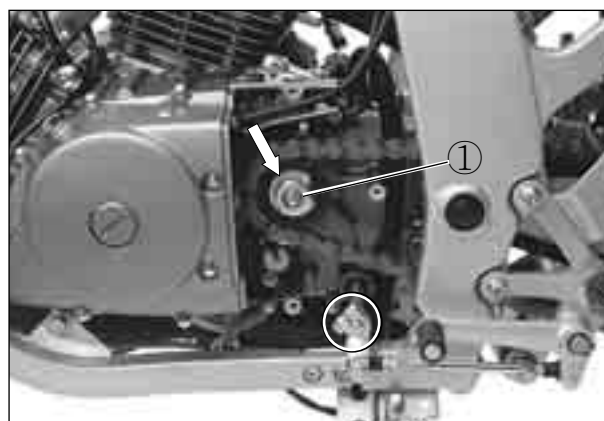

- Remove the engine sprocket.

NOTE

If it is difficult to remove the engine sprocket, loosen the rear axle nut, chain adjusters ② · ③ to provide additional chain slack. (Refer to page 2-11)

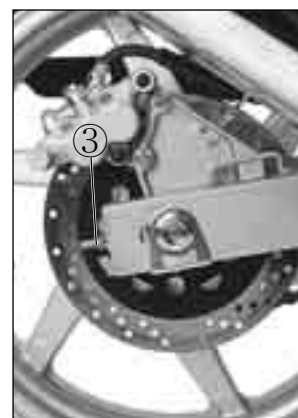
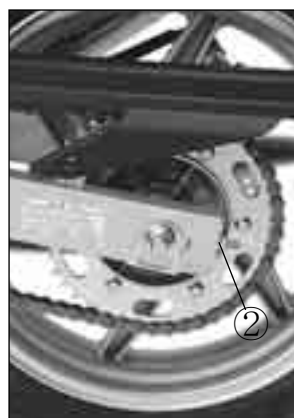

3-5 ENGINE

- Remove the oil cooler.



- Support the engine using an engine jack.
- Remove the engine mounting nuts and bolts.
- Remove the engine from the frame.

CAUTION

Remove the carburetor when removing or installing the engine necessarily.
When removing the carburetor, loosen the intake pipe mounting bolts at the same time.

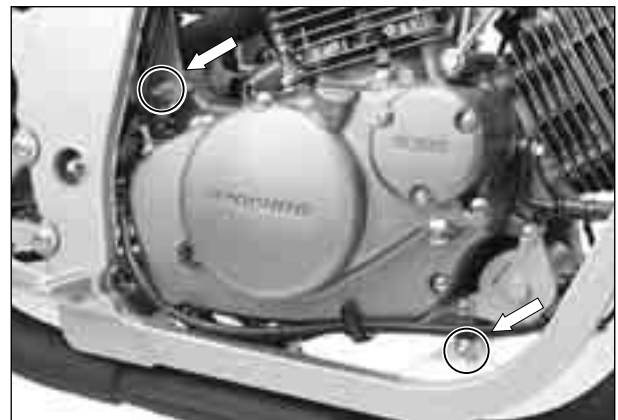

ENGINE REINSTALLATION

Reinstall the engine in the reverse order of engine removal.

- Install the engine mounting bolts and nuts.
- Tighten the engine mounting bolts and nuts to the specified torque.

 **Engine mounting bolt**
: 40~60 N · m (4.0~6.0 kg · m)

⊙ **ENGINE SPOCKET**

- Loosen the rear axle nut and chain adjusters, left and right.
- Install the engine sprocket.



- Tighten the engine sprocket nut ① to the specified torque.

🔧 Engine sprocket nut
 : 80~100 N · m (8.0~10.0 kg · m)

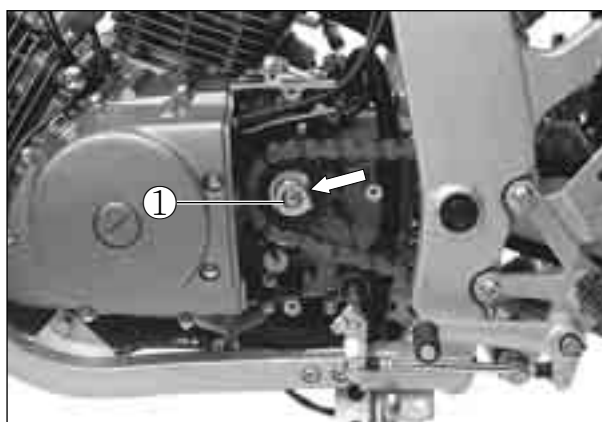

NOTE

When tightening the engine sprocket nut, depress the rear brake pedal.

- Bend the lock washer securely.
- Install the gearshift arm and adjust the gearshift lever height.(Refer to page 2-9)
- Connect each electric part and its couplers.(Refer to page 7-23~30)
- Install the exhaust pipes and mufflers.
- Install the carburetor and air cleaner.



- After remounting the engine, the following adjustments are necessary.

Engine idling speed	Refer to page 2-7
Throttle cable play	Refer to page 2-7
Clutch cable play	Refer to page 2-8
Drive chain	Refer to page 2-11
Gearshift lever height	Refer to page 2-9
Engine oil level	Refer to page 2-9

ENGINE DISASSEMBLY

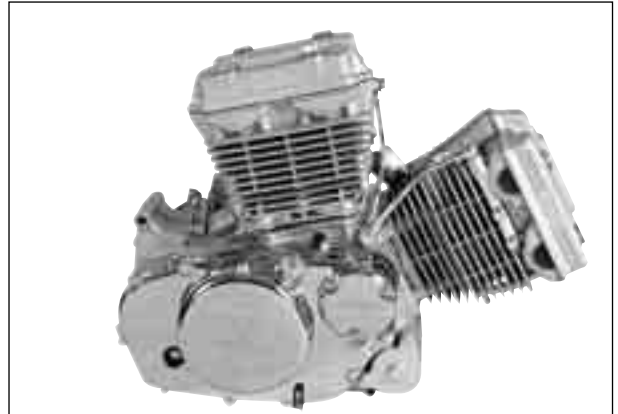

STARTER MOTOR

- Remove the starter motor.

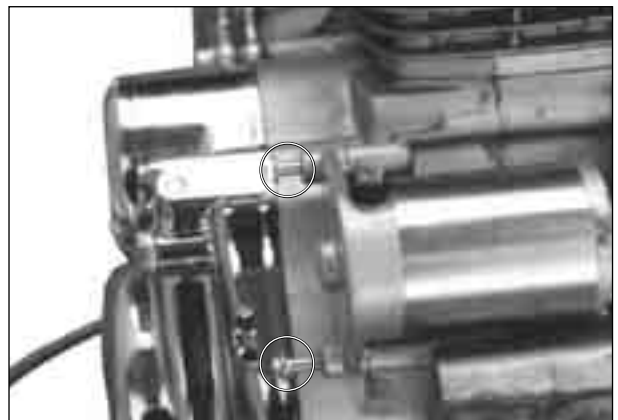

- Remove the gear position switch.
- Remove the contacts ① and springs ②.

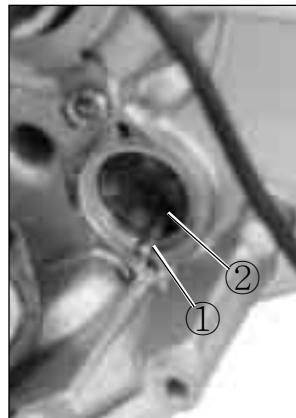

- Remove the three union bolts.

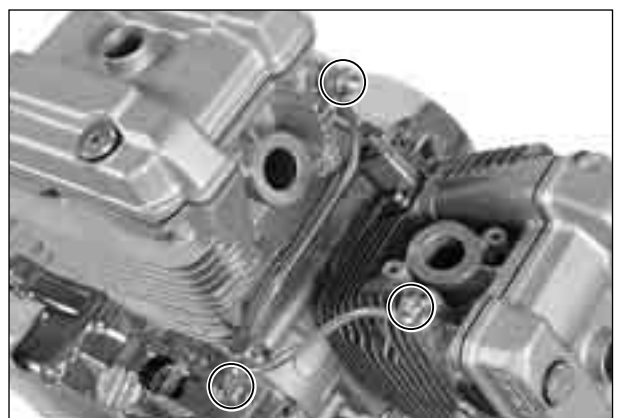

CYLINDER HEAD COVER

- Remove the cylinder head cover.

- To set the piston at TDC(Top Dead Center).

CAUTION

Align the index mark on the magneto rotor with the index mark on the magneto cover as turn the crankshaft counter-clockwise.

To set piston at TDC(Top Dead Center) of the compression stroke as align the “ | F” mark for front cylinder and the “ | R” mark for rear cylinder.

- Remove the cam chain tensioner.

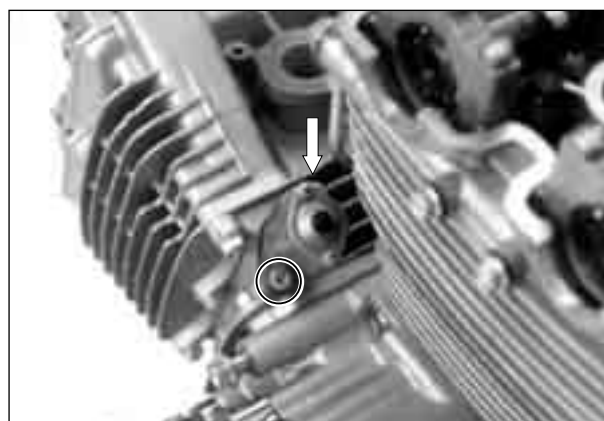
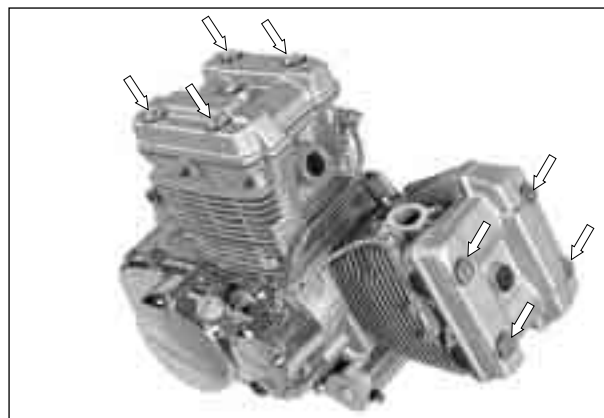

[Front Cylinder]



[Rear Cylinder]

3-9 ENGINE

- With the three bolts removed, remove the cam chain guide NO.2.

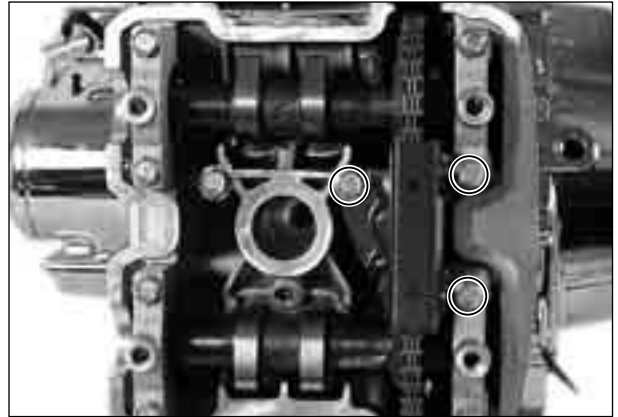

- Remove the camshaft housing.

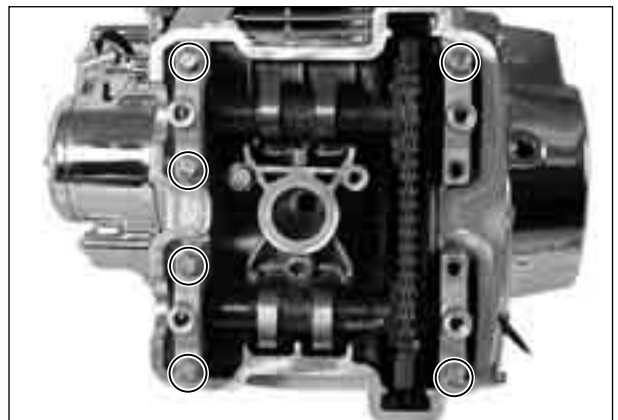

- Remove the camshaft (IN. · EX.).



- Remove the C-ring.



- Loosen the two cylinder head base cover nuts.

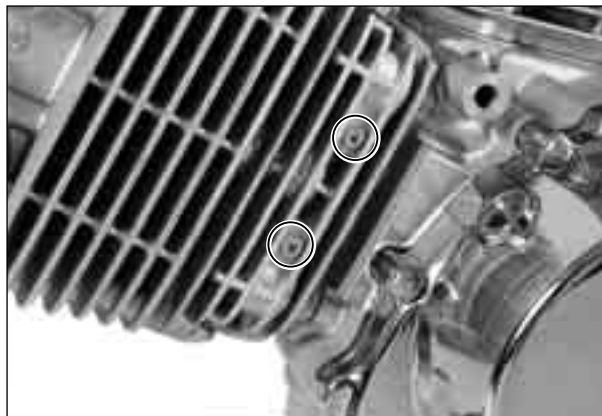

- Loosen the three cylinder head base nuts.

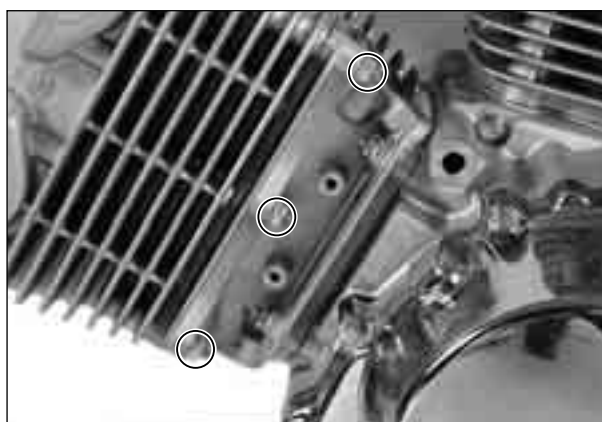

- Loosen the four cylinder head stud bolts.

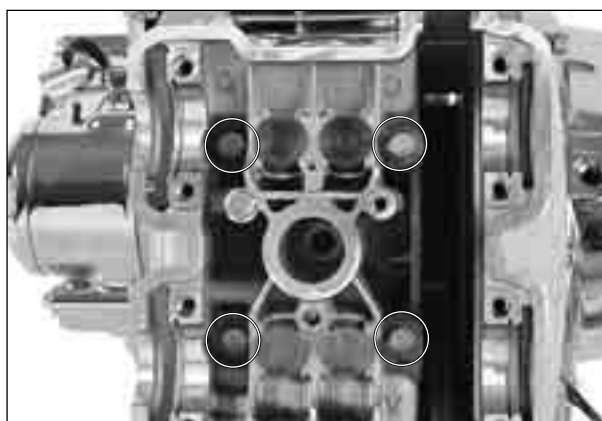

- Remove the chain guide NO.1 and cylinder head.



3-11 ENGINE

- Remove the tappet and the shim.

 **CAUTION**

Draw out the tappet and shim with the strong magnet not to be scratched.



 **CAUTION**

The tappet and shim should be lined so that each will be restored to the original position during reassembly.

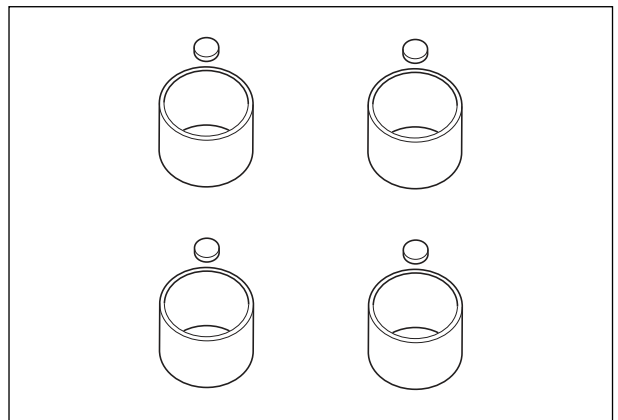

- Compress the valve spring by using the special tool.

 **Valve spring compressor : 09916-14510**
Valve spring compressor attachment
: 09916H35C00 (『Comet-250』)
Valve spring compressor attachment
: 09916H5100 (『Comet-125』)



- Take out the valve cotter from the valve stem.
- Remove the valve spring retainer.
- Pull out valve from the other side.

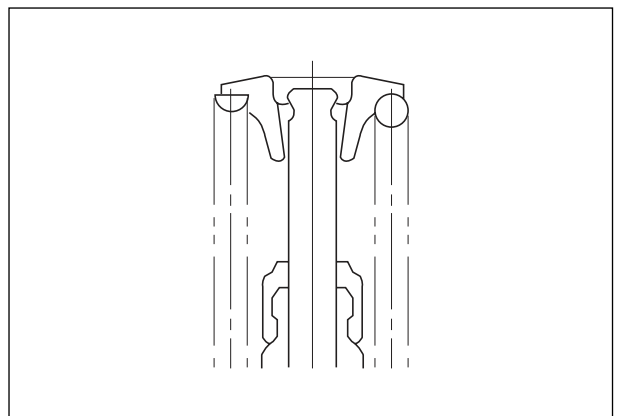

- Remove the two cylinder base nuts and cylinder.

CAUTION

If tapping with the plastic hammer is necessary, pay attention to break the fins.



- Remove the rear cylinder head and cylinder with the same manner of the front cylinder head and cylinder removal.

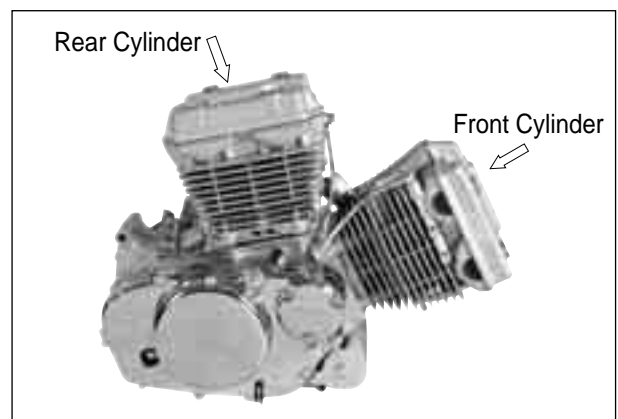

PISTON

- Place a clean rag over the cylinder base to prevent piston pin circlips from dropping into crankcase. Remove the piston pin circlips with long-nose pliers.



- Remove the piston pin by using the special tool.

 **Piston pin puller : 09910-34510**

NOTE

Make an identification on each piston head so that confirmed the cylinder.



MAGNETO COVER

- Remove the magneto cover.

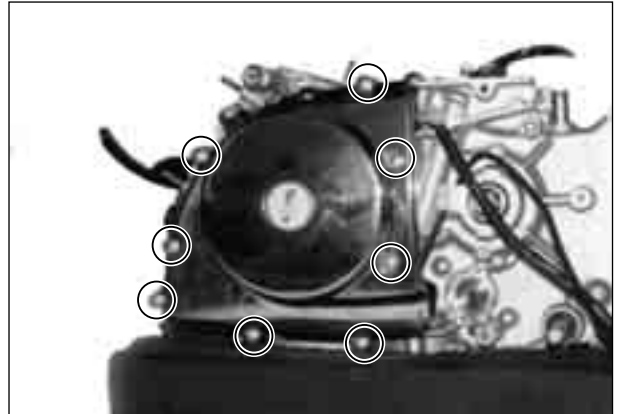

- Remove in the order of spacer ①, shaft ②, starter idle gear ③.



MAGNETO ROTOR

- With the magneto rotor held immovable using the special tool, loosen the rotor nut.

 **Conrod holder : 09910-20115**



- Remove the magneto rotor by using the special tool.

 **Rotor remover (『 Comet 250 』)**
: 09930-30164
Rotor remover (『 Comet 125 』)
: 09930-30162
Rotor remove sliding shaft
: 09930-30102



- Remove the key ①.
- Remove the starter driven gear ②.

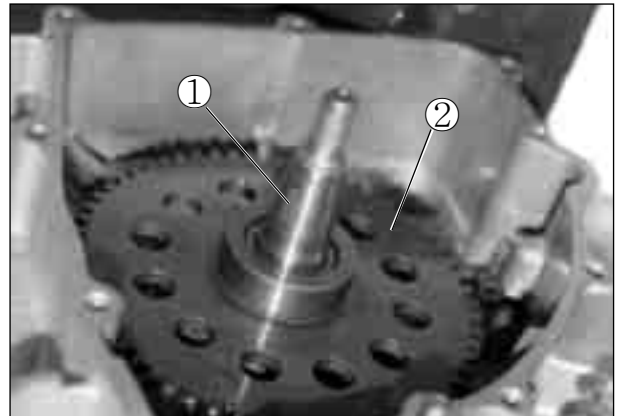

- Remove the cam chain tensioner ③ and cam chain ④.

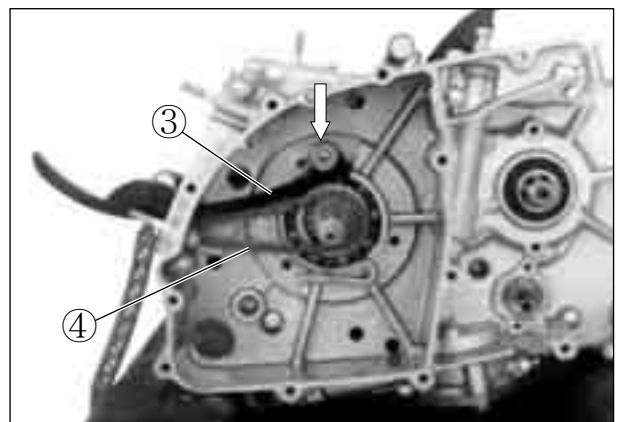

CLUTCH COVER

- Remove the clutch release arm .

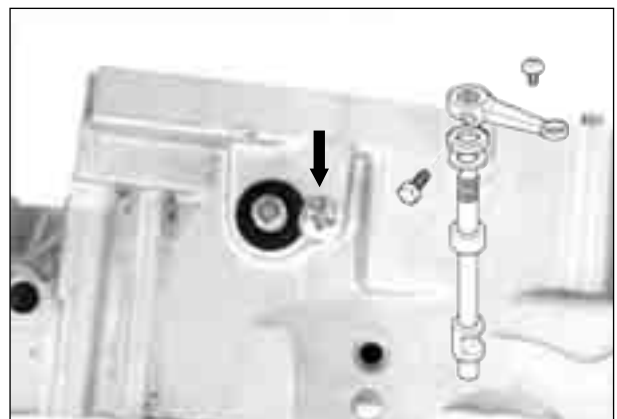

- Remove the clutch cover bolts.
- Remove the clutch cover.

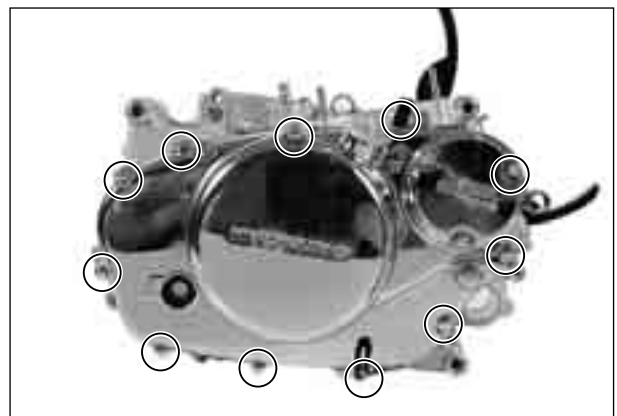

3-15 ENGINE

CLUTCH

- With the primary drive gear held immovable, remove the clutch spring mounting bolts diagonally.
- Remove the disk pressure ①.

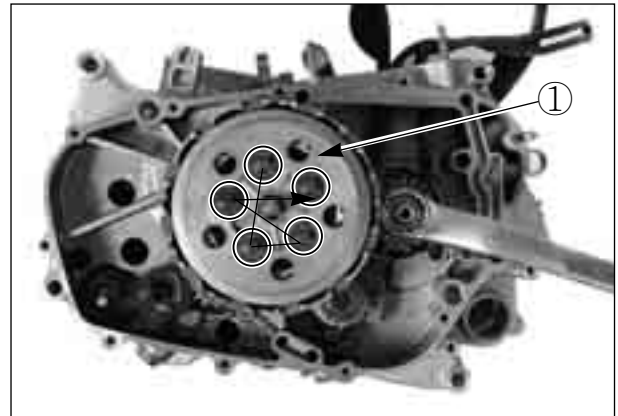

- Remove the clutch drive and driven plates.



- Flatten the lock washer ②.

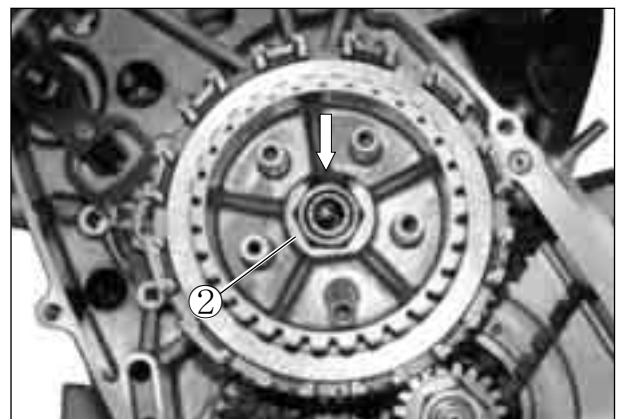

- With the clutch sleeve hub held immovable using special tool, remove the clutch sleeve hub nut.

 **Clutch sleeve hub holder : 09920-53710**

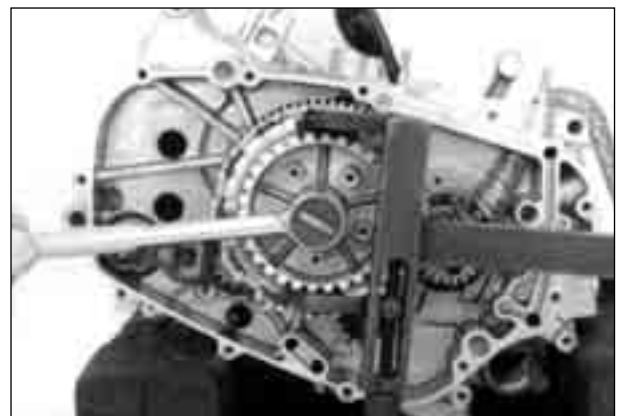

- Remove the clutch sleeve hub ① and primary driven gear assembly ② .

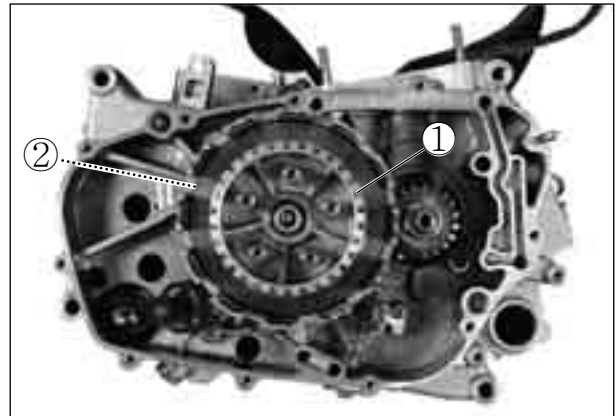

PRIMARY DRIVE GEAR

- With the magneto rotor held immovable using special tool, remove the primary drive gear nut.

 **Conrod holder : 09910-20115**

CAUTION

This bolt has left-hand thread. If turning it counter-clockwise() , it may cause damage. Pay attention at the primary drive gear with two washer.



- Remove the key and cam chain ③.
- Remove the cam chain tensioner ④ .

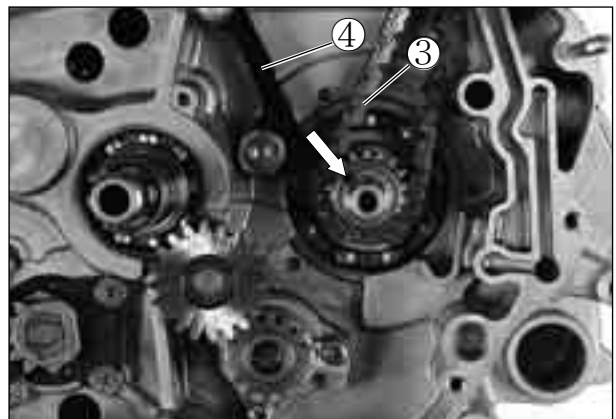

OIL PUMP

- Remove the circlip ⑤ and oil pump driven gear.



3-17 ENGINE

- Remove the pin ①.
- With the three screws loosened, remove the oil pump ②.

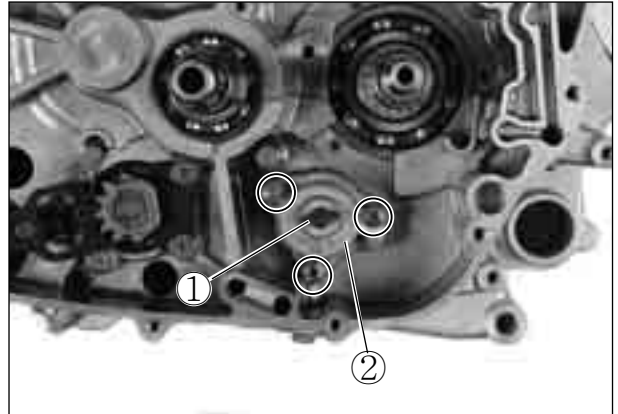

GEARSHIFT SHAFT

- Draw out the gearshift shaft ③.

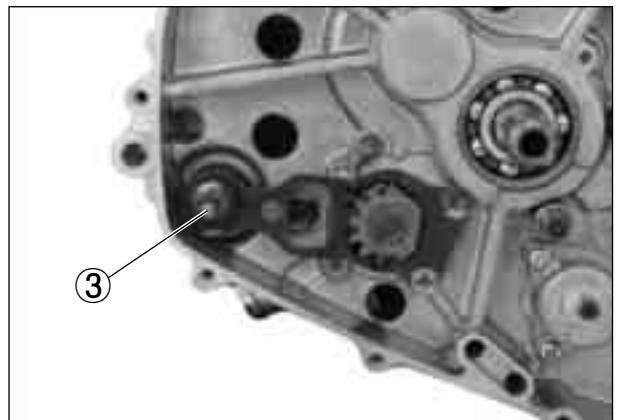

- With the cam guide screws loosened, draw out the guide and lifter.
- Remove the cam driven gear.

⚠ CAUTION

Pay attention to not lost the gearshift pawl, pin, spring with the cam driven gear removal.

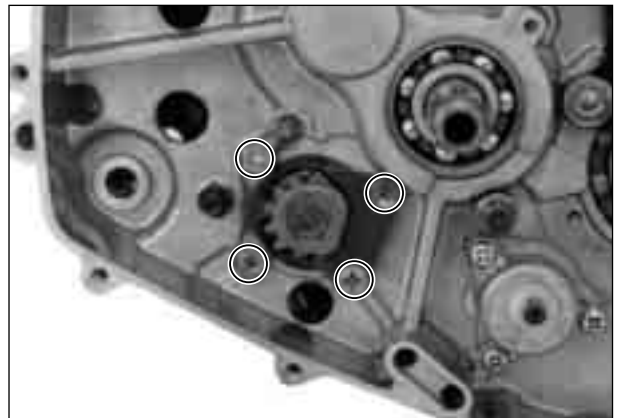

- With the neutral cam stopper plug loosened, remove the washer, spring, stopper.

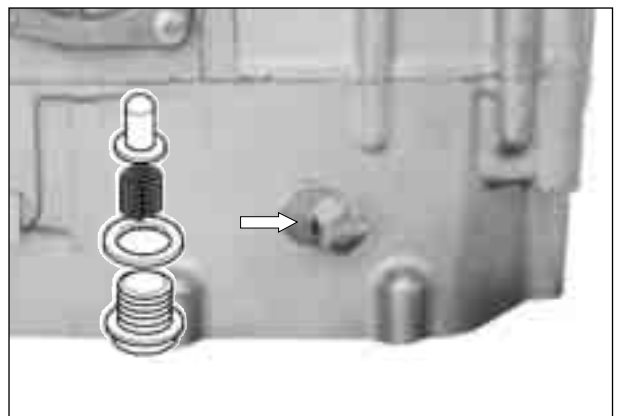

- Remove the crankcase securing bolts.
- Separate the crankcase into 2 parts, right and left, with a special tool.

 **Crankcase separator : 09920-13120**

CAUTION

When separating the crankcase, necessarily, remove it after installed the special tool (Crankcase separator) on the side of clutch.

In case separate oppositely, the gearshift cam stopper will be damaged in the side of magneto.

NOTE

Fit the crankcase separator, so that the tool arms parallel the side of the crankcase.

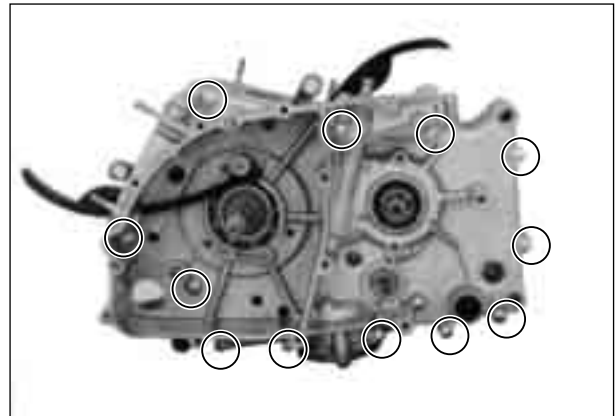

- Remove the gearshift fork shaft ① and gearshift fork ②.
- Remove the gearshift cam ③.
- Remove the driveshaft assembly ④, countershaft assembly ⑤.
- Remove the oil pump idle gearshaft ⑥.

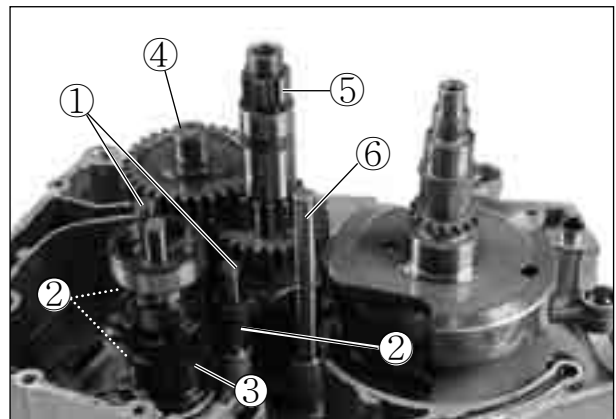

- Remove the crankshaft by using the special tool.

 **Crankcase separator : 09920-13120**



ENGINE COMPONENT INSPECTION AND SERVICE

CAUTION

Be sure to identify each removed part as to its location, and lay the parts out in groups designated as “Front cylinder”, “Rear cylinder”, “Exhaust”, “Intake”, so that each will be restored to the original location during assembly.



⊙ CYLINDER HEAD DISTORTION

Decarbonate in combustion chamber.
Check the gasketed surface of the cylinder head for distortion with a straightedge and thickness gauge, taking a clearance reading at several places as indicated. If the largest reading at any position of the straightedge exceeds the limit, replace the cylinder head.

Cylinder head distortion	Service limit
	0.05 mm (0.002 in)

 Thickness gauge : 09900-20806

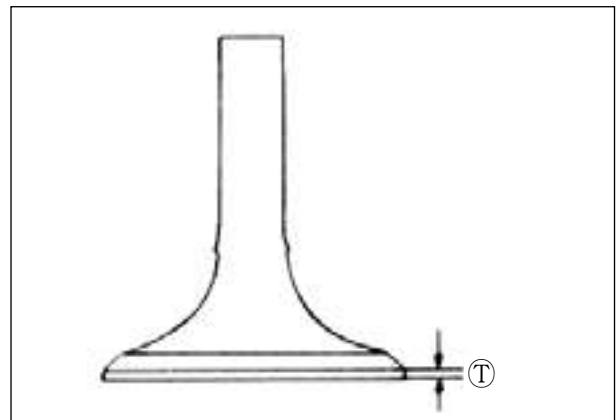

⊙ VALVE FACE WEAR

Visually inspect each valve face for wear. Replace any valve with an abnormally worn face. The thickness of the valve face decreases as the face wears. Measure the valve head T . If it is out of specification, replace the valve with a new one.

Valve head thickness T	Service limit
	0.5 mm (0.02 in)

 Vernier calipers : 09900-20101

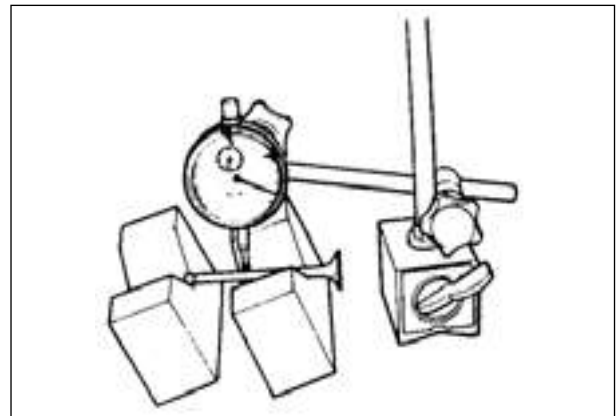

⊙ VALVE STEM RUNOUT

Check the valve stem for abnormal wear or bend. Place the valve on V-blocks and measure runout. If the service limit is exceeded or abnormal condition exists, replace the valve.

Valve stem runout	Service limit
	0.05 mm (0.002 in)

 Dial gauge : 09900-20606
Magnetic stand : 09900-20701
V-block : 09900-21304

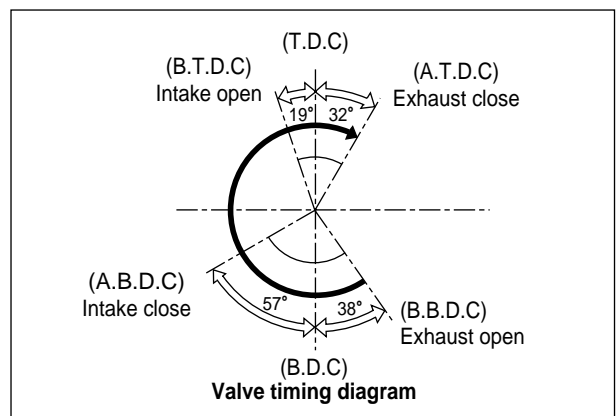

⊙ **CAMSHAFT**

The camshaft should be checked for runout and also for wear of cams and journals if the engine has been noted to produce abnormal noise or vibration or a lack of output power. Any of these abnormality could be caused by a worn camshaft.

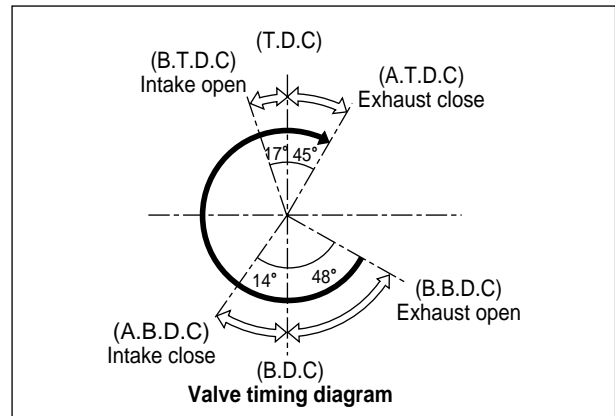

『Comet 125』

■ **CAMSHAFT WEAR**

Worn-down cams are often the cause of mistimed valve operation resulting in reduced output power. The limit of cam wear is specified for both intake and exhaust cams in terms of cam height (H), which is to be measured with a micrometer. Replace camshafts if found it worn down to the limit.

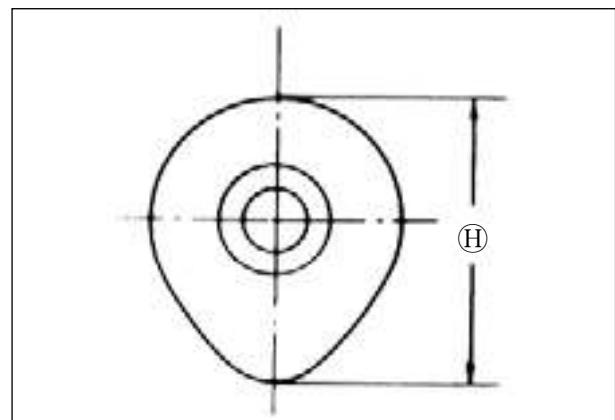

Cam height (H)	Service limit
Intake cam	34.170 mm (1.345 in)
Exhaust cam	34.120 mm (1.343 in)

 **Micrometer(25~50 mm) : 09900-20202**

⊙ **Tappet & shim wear**

When measuring the valve clearance, the clearance should be within the standard range.



Valve clearance	Standard(When cold)
Intake valve	0.1~0.2 mm (0.004~0.008 in)
Exhaust valve	0.2~0.3 mm (0.008~0.012 in)

- Inspect the tappet for wear and scratch. If modification or scratch is present, replace the tappet.
- The shim has various size. Replace the thin shim to valve clearance is narrow, or the thick shim to valve clearance is wide as that shim thickness was installed with standard at present. (Refer to page 7-33 · 34)

■ **SHIM KIND**

There are 41 kinds of shim which thickness is increased by each 0.025 mm from 1.20 mm to 2.20 mm.

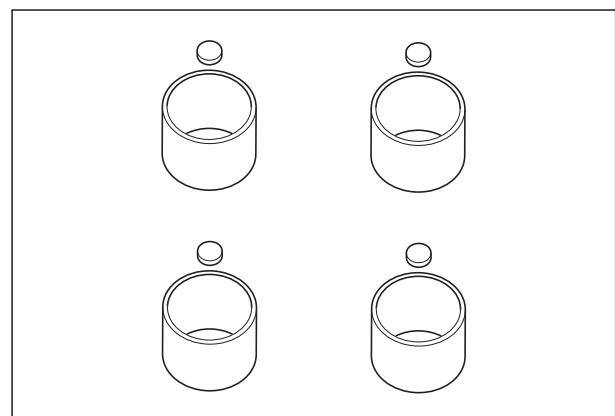

⊙ **VALVE HEAD RADIAL RUNOUT**

Place a dial gauge as shown and measure valve head radial runout.

If the service limit is exceeded, replace the valve.

Valve head radial runout	Service limit
	0.03 mm (0.0012 in)

-  **Dial gauge : 09900-20606**
- Magnetic stand : 09900-20701**
- V-block : 09900-21304**

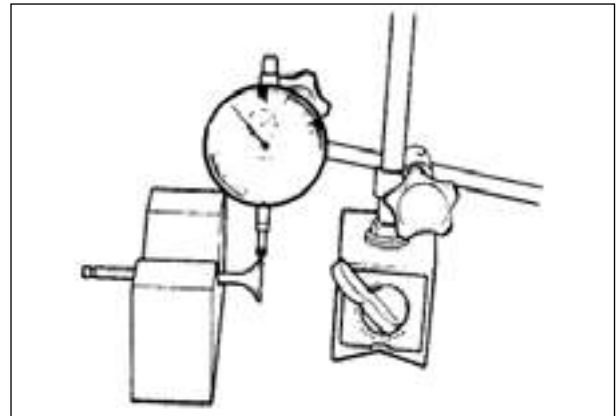

⊙ **VALVE GUIDE-VALVE STEM CLEARANCE**

Measure the clearance in the valve guide-valve stem, by rigging up the dial gauge as shown. If the clearance is measured exceeds the limit specified below, then determine whether the valve or the guide should be replaced to reduce the clearance to within the standard range:

Valve guide-valve stem clearance	Standard
IN.	0.010~0.037 mm (0.0004~0.0015 in)
EX.	0.030~0.057 mm (0.0012~0.0022 in)

-  **Dial gauge : 09900-20606**
- Magnetic stand : 09900-20701**

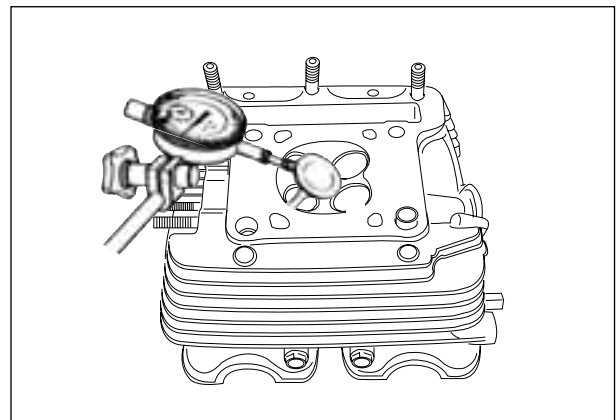

⊙ **VALVE STEM DIAMETER**

Measure the valve stem outside diameter.

If the diameter measured exceeds the standard, replace the valve.

Valve stem diameter	Standard	
	『Comet 250』	『Comet 125』
IN.	4.475~4.490 mm (0.1762~0.1768 in)	3.975~3.990 mm (0.1565~0.1571 in)
EX.	4.455~4.470 mm (0.1754~0.1760 in)	3.955~3.970 mm (0.1557~0.1563 in)

-  **Micrometer(0~25 mm) : 09900-20201**

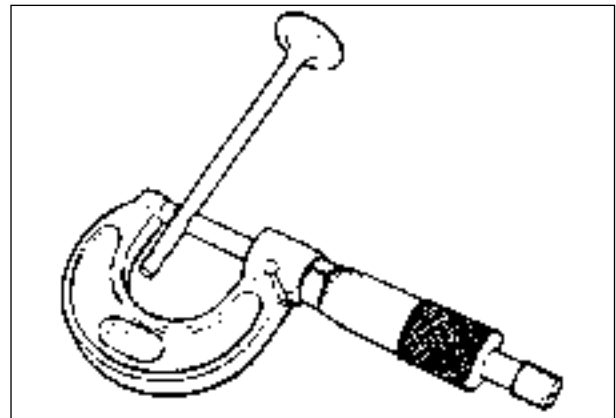

⊙ **VALVE SPRING**

The force of the coil spring keeps the valve seat tight. A weakened spring results in reduced engine power output and often accounts for the chattering noise coming from the valve mechanism.

Check the valve springs for proper strength by measuring their free length and also by the force required to compress them. If the spring length is less than the service limit or if the force required to compress the spring does not fall within the specified range, replace both the inner and outer springs as a set.

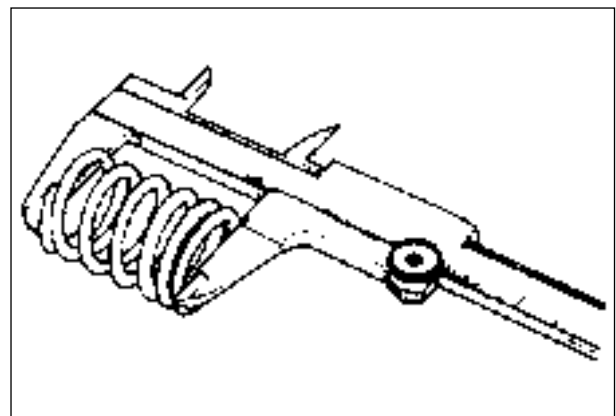

Valve spring free length(IN. & EX.)	Service limit	
	『Comet-250』	『Comet-125』
	37.80 mm (1.488 in)	37.64 mm (1.482 in)

 **Venier calipers : 09900-20101**

Valve spring tension (IN. & EX.)	Standard	
	『Comet-250』	『Comet-125』
	12.0~13.9 kgf (26.7~30.6 lbs) at length 33.7 mm (1.33 in)	30.0 kgf (66.1 lbs) at length 27.95 mm (1.10 in)

⊙ **CYLINDER DISTORTION**

Check the gasketed surface of the cylinder for distortion with a straightedge and thickness gauge, taking a clearance reading at several places as indicated. If the largest reading at any position of the straightedge exceeds the limit, replace the cylinder.

Cylinder distortion	Service limit
	0.05 mm (0.002 in)

 **Thickness gauge : 09900-20806**

⊙ **CYLINDER BORE**

Measure the cylinder bore diameter at six place. If any one of the measurements exceeds the limit, overhaul the cylinder and replace the piston with an oversize, or replace the cylinder.

『Comet-250』

Cylinder bore	Standard	Service limit
	57.000~57.015 mm (2.2441~2.2447 in)	57.080 mm (2.2473 in)

『Comet-125』

Cylinder bore	Standard	Service limit
	44.000~44.015 mm (1.7323~1.7329 in)	44.080 mm (1.7354 in)

 **Cylinder gauge set : 09900-20508**

⊙ **CAM CHAIN TENSION ADJUSTER**

Check that the push rod slides smoothly with the lock shaft handle ① clockwise.

If it does not slide smoothly, replace the cam chain tension adjuster with a new one.

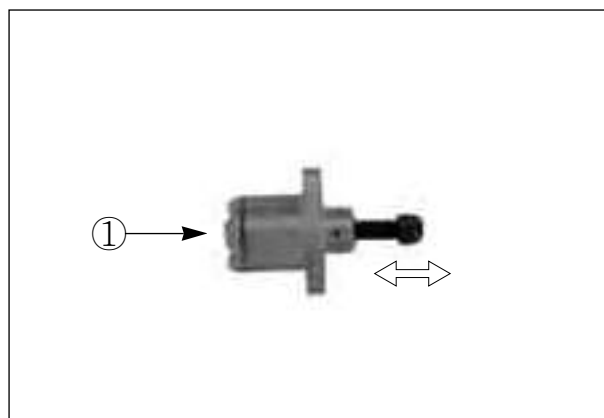
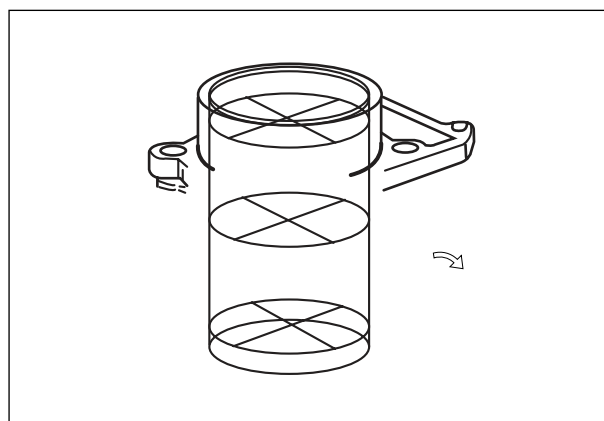
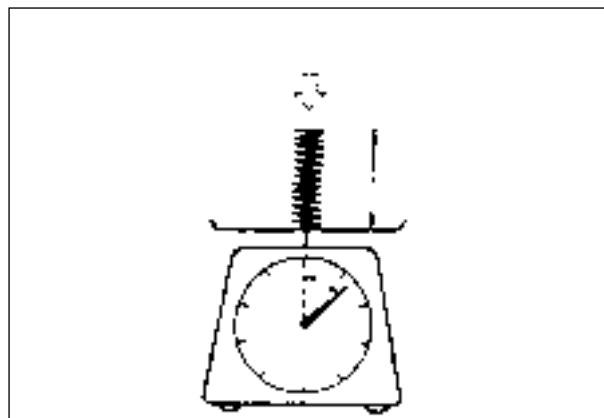

⊙ **CAM CHAIN TENSIONER**

Check the contacting surface of the cam chain tensioner. If it is worn or damaged, replace it with a new one.

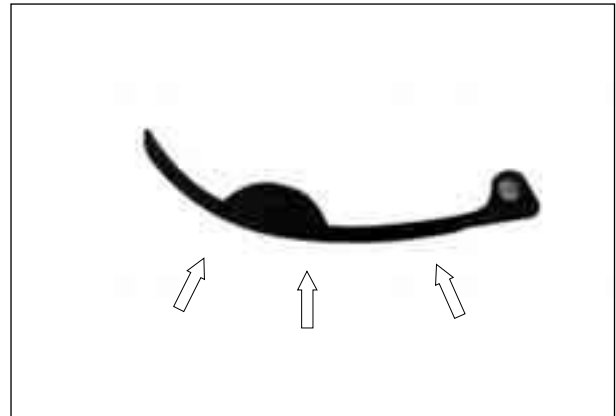

⊙ **CAM CHAIN AND CAM CHAIN GUIDE**

Check the cam chain for wear, damage and kinked or binding links. If any defects are found, replace it with a new one.

Check the cam chain guide for wear and damage. If it is found to be damaged, replace it with a new one.

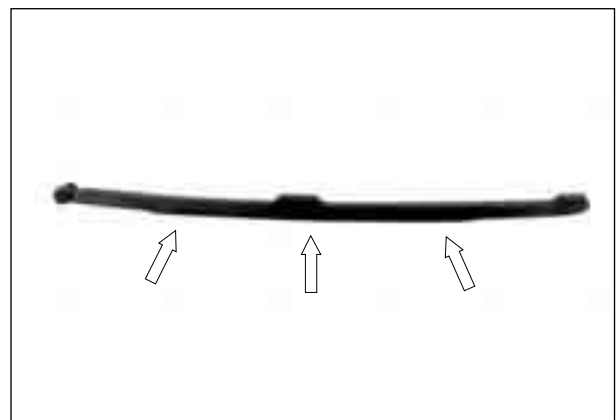

⊙ **PISTON DIAMETER INSPECTION**

Measure the outside diameter of piston in the direction perpendicular to the piston pin axis at the height from the skirt as shown in the illustration using a micrometer.

If the measurement is found less than the service limit, replace the piston.

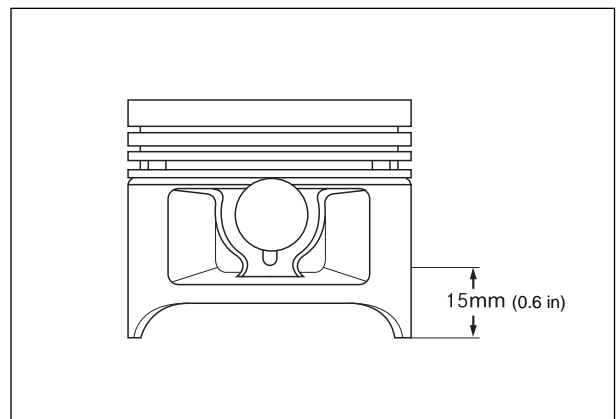

Piston diameter	Service limit	
	『 Comet 250 』	『 Comet 125 』
	56.880 mm (2.2394 in)	43.890 mm (1.7280 in)

Piston oversize	0.5, 1.0 mm (0.02, 0.04 in)
------------------------	-----------------------------

 **Micrometer(50~75 mm) : 09900-20203**

Micrometer(25~50 mm) : 09900-20202

⊙ **PISTON-TO-CYLINDER CLEARANCE**

To determine the piston-to-cylinder clearance, calculate the difference between the cylinder bore and outside diameter of the piston.

『 Comet 250 』

Piston-to-cylinder clearance	Standard	Service limit
	0.05~0.06 mm (0.0020~0.0024 in)	0.120 mm (0.0047 in)

『 Comet 125 』

Piston-to-cylinder clearance	Standard	Service limit
	0.03~0.04 mm (0.0012~0.0016 in)	0.1 mm (0.0040 in)

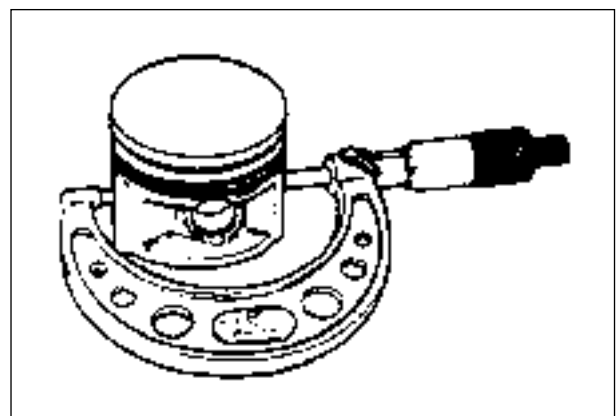

⊙ PISTON PIN HOLE BORE

Using a dial calipers, measure the piston pin hole bore both in the vertical and horizontal directions.

If the measurement exceeds the service limit, replace the piston.

Piston pin hole bore	Service limit	
	『Comet 250』	『Comet 125』
	15.030 mm (0.5917 in)	13.030 mm (0.513 in)

 Dial calipers : 09900-20605

⊙ PISTON PIN DIAMETER INSPECTION

Using a micrometer, measure the piston pin outside diameter at three position, both the ends and the center.

If any of the measurements is founds less than the service limit, replace the pin.

Piston pin diameter	Service limit	
	『Comet 250』	『Comet 125』
	14.980 mm(0.5898 in)	13.980 mm(0.550 in)

 Micrometer(0~25 mm) : 09900-20201

⊙ PISTON RING FREE END GAP INSPECTION

Before installing piston rings, measure the free end gap of each ring using vernier calipers. If the gap is less than the service limit, replace the ring.

Piston ring free end gap	Standard	
	『Comet 250』	『Comet 125』
1st	7.2 mm (0.284 in)	5.0 mm (0.197 in)
2nd	5.8 mm (0.228 in)	6.0 mm (0.236 in)

Piston ring free end gap	Service limit	
	『Comet 250』	『Comet 125』
1st	5.7 mm (0.224 in)	4.0 mm (0.158 in)
2nd	4.6 mm (0.181 in)	4.8 mm (0.189 in)

 Vernier calipers : 09900-20101

⊙ PISTON RING END GAP INSPECTION

Insert the piston ring squarely into the cylinder using the piston head.

Measure the end gap with a thickness gauge.

If the gap exceeds the service limit, replace the piston ring.

Piston ring end gap (Assembly condition)	Standard	
	『Comet 250』	『Comet 125』
1st	0.20~0.32 mm (0.008~0.013 in)	0.10~0.25 mm (0.004~0.010 in)
2nd	0.20~0.32 mm (0.008~0.013 in)	0.25~0.40 mm (0.010~0.016 in)

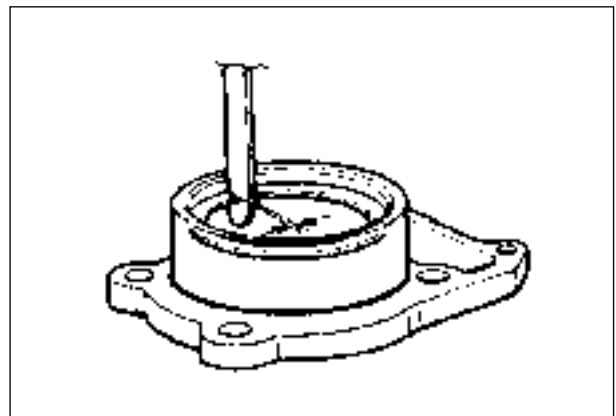
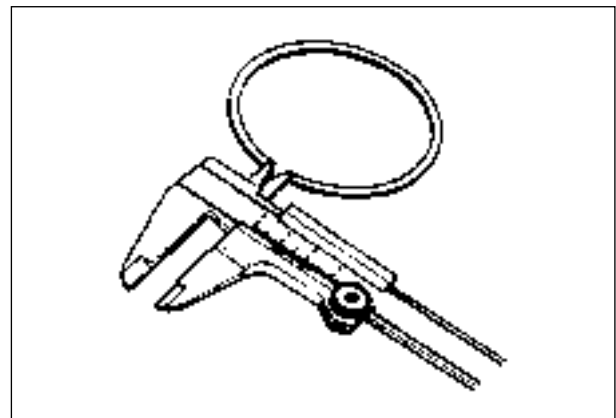
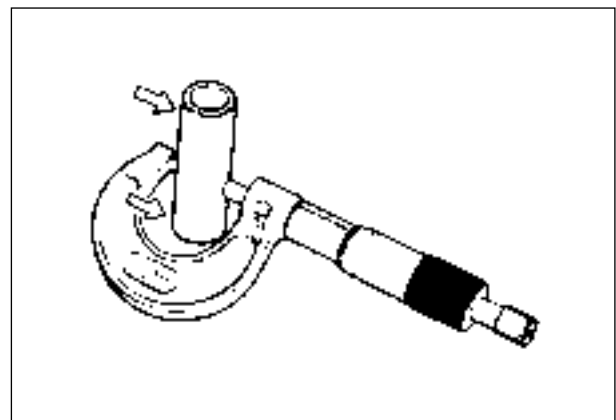
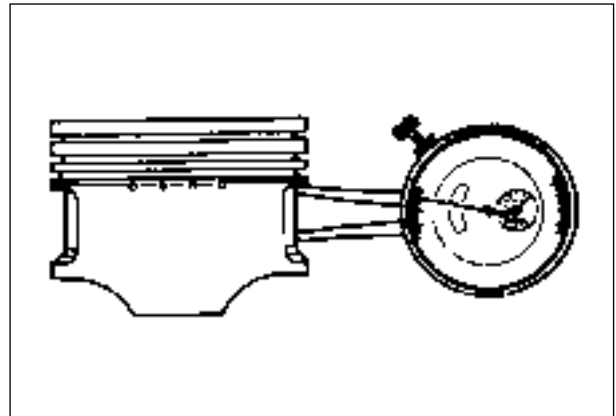

3-25 ENGINE

Piston ring end gap(Assembly condition)	Service limit
1st	0.5 mm (0.02 in)
2nd	0.5 mm (0.02 in)

 Thickness gauge : 0990-20806

⊙ PISTON RING-TO-GROOVE CLEARANCE INSPECTION

Remove carbon deposit both from the piston ring and its groove.

Fit the piston ring into the groove. With the ring compressed and lifted up, measure the clearance on the bottom side of the ring using a thickness gauge.

Piston ring-groove clearance	Service limit
1st	0.180 mm (0.007 in)
2nd	0.150 mm (0.006 in)

Piston ring-groove width	Standard
1st	1.01~1.03 mm (0.040~0.041 in)
2nd	1.01~1.03 mm (0.040~0.041 in)
Oil	2.01~2.03 mm (0.079~0.080 in)

Piston ring thickness	Standard
1st	0.970~0.990 mm (0.0382~0.0390 in)
2nd	0.970~0.990 mm (0.0382~0.0390 in)

 Thickness gauge : 09900-20806
Micrometer(0~25 mm) : 09900-20201

⊙ OVERSIZE RINGS

■ Oversize piston ring

The following two types of oversize piston ring are used. They bear the following identification numbers.

Oversize piston ring	1st	2nd
0.5 mm	05	05
1.0 mm	10	10

■ Oversize oil ring

The following two types of oversize oil ring are used. They bear the following identification marks.

Oversize oil ring	Color classification
0.5 mm	Painted red
1.0 mm	Painted yellow

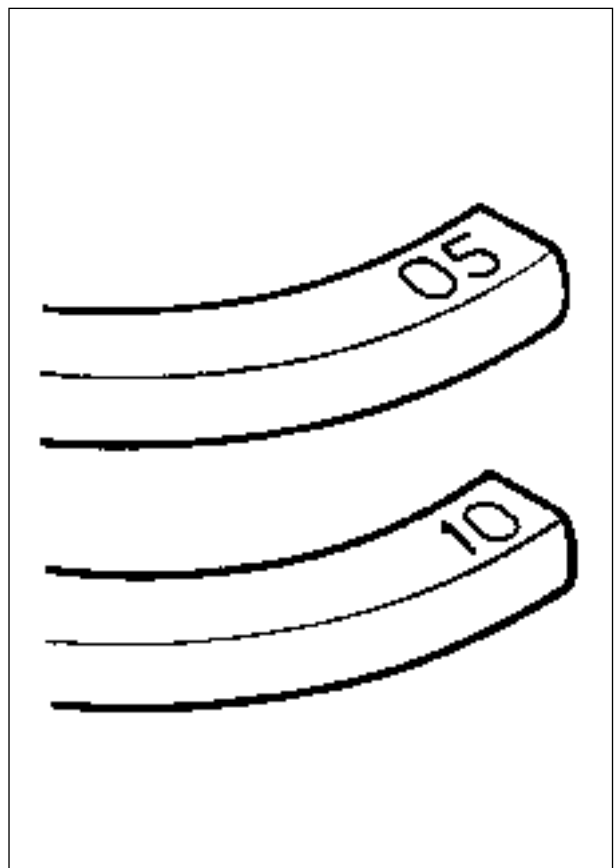
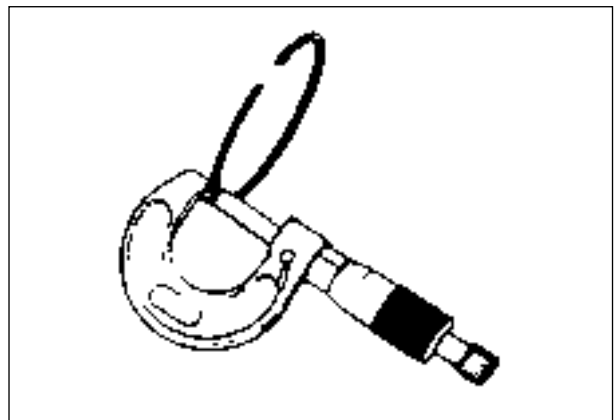
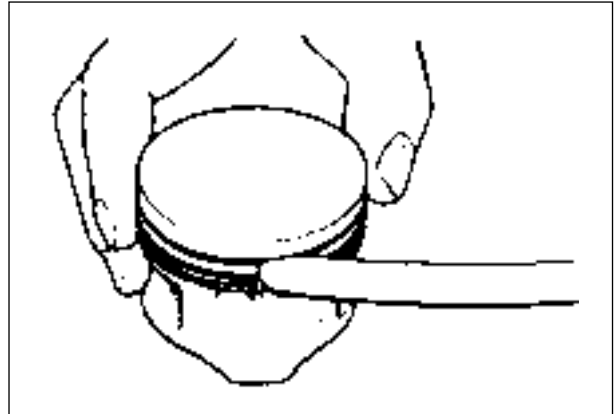

⊙ CONROD SMALL END INSIDE DIAMETER INSPECTION

Using a dial calipers, measure the conrod small end inside diameter both in vertical and horizontal directions. If any of the measurements exceeds the service limit, replace the conrod.

『Comet-250』

	Standard	Service limit
Conrod small end I.D.	15.006~15.014 mm	15.040 mm
	(0.5908~0.5911 in)	(0.5921 in)

『Comet-125』

	Standard	Service limit
Conrod small end I.D.	13.006~13.014 mm	13.040 mm
	(0.5121~0.5124 in)	(0.5134 in)

 **Dial calipers : 09900-20605**

⊙ CONROD DEFLECTION INSPECTION

Move the small end sideways while holding the big end immovable in thrust direction.

Measure the amount of deflection.

Turn the conrod and see if it moves smoothly without play and noise. This method can check the extent of wear on the parts of the conrod's big end.

Conrod deflection	Service limit
	3.0mm (0.12 in)

⊙ CONROD BIG END SIDE CLEARANCE INSPECTION

Using a thickness gauge, measure the side clearance at the conrod big end. If the measurement is out of standard value, measure the conrod big end and the crank pin widths individually to determine which one is to be replaced.

『Comet-250』

	Standard	Service limit
Conrod big end side clearance	0.40~0.85 mm	1.0 mm
	(0.016~0.034 in)	(0.040 in)

『Comet-125』

	Standard	Service limit
Conrod big end side clearance	0.15~0.40 mm	1.0 mm
	(0.006~0.016 in)	(0.040 in)

⊙ CRANKSHAFT RUNOUT INSPECTION

With the right and left crank journals supported with V-block, turn the crankshaft slowly. At this time, measure the crankshaft end runout using a dial gauge. If the runout exceeds the service limit, replace the crankshaft.

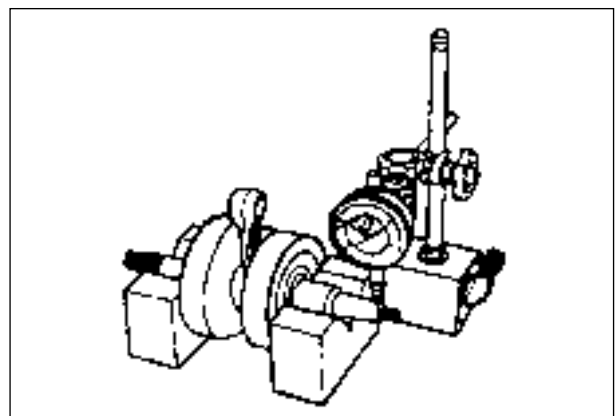
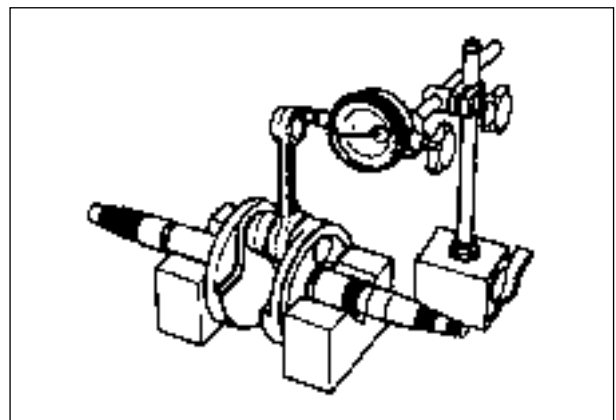
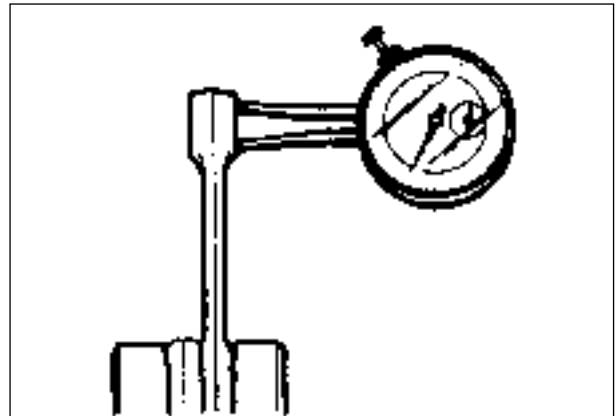

3-27 ENGINE

Crankshaft runout	Service limit
	0.05 mm (0.002 in)

-  **Magnetic stand : 09900-20701**
- Dial gauge : 09900-20606**
- V-block : 09900-21304**

⊙ **CRANKSHAFT REASSEMBLY**

Measure the width between the webs referring to the figure below when rebuilding the crankshaft.

Width between webs	Standard
	72 ± 0.1 mm (2.84 ± 0.004 in)

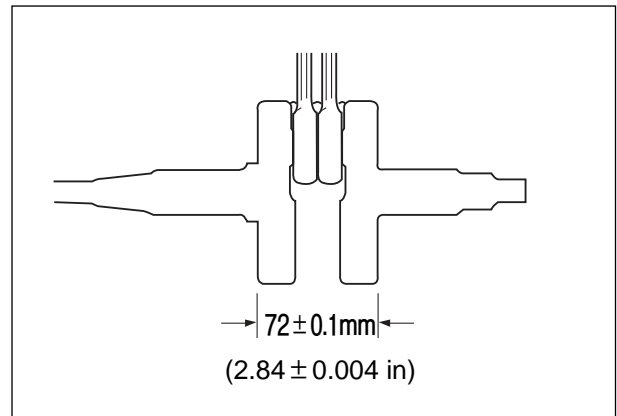

⊙ **MAGNETO COVER**

■ **MAGNETO INSPECTION(Refer to page 5-4)**

■ **DISASSEMBLY**

- Remove the stator ①.

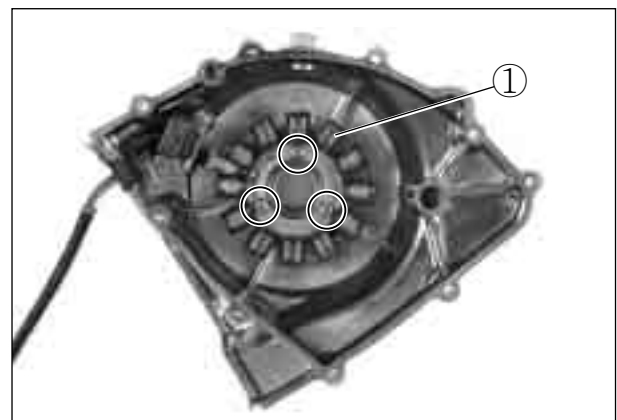

⊙ **STARTER CLUTCH**

Install the starter driven gear onto the starter clutch and turn the starter driven gear by hand(the gear turns in only one direction). The starter driven gear should turn smoothly. If excessive resistance is felt while turning the starter driven gear, inspect the starter clutch. Also, inspect the surface of the starter driven gear which contacts the starter clutch, for wear or damage. If any wear or damage is found, replace the defective parts.



■ **DISASSEMBLY**

- Hold the magneto rotor with the rotor holder and remove the starter clutch bolts.

-  **Rotor holder : 09930-44510**



■ REASSEMBLY

- Apply a small quantity of THREAD LOCK “1324” to the starter clutch bolts and tighten them to the specified torque while holding the rotor with the rotor holder.

 Thread Lock “1324”

 Rotor holder : 09930-44510

 Starter clutch bolt
: 15~20 N · m(1.5~2.0 kg · m)



⊙ STARTER DRIVEN GEAR

■ STARTER DRIVEN GEAR BUSHING

Install the starter driven gear bushing ① and gear ② onto the crankshaft and turn the starter driven gear by hand. Inspect the starter driven gear bushing for smooth rotation and any abnormal noise. If the bushing does not turn smoothly or there is any abnormal noise, replace it.

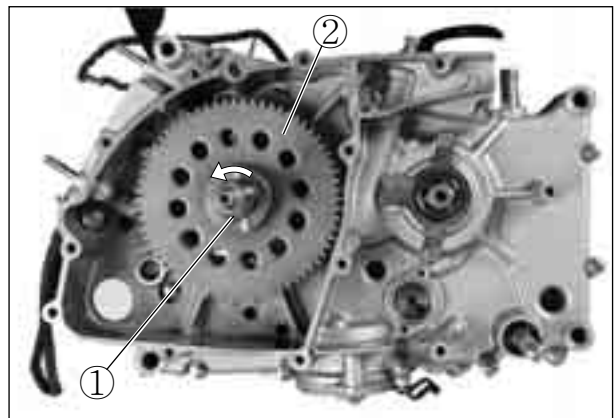

⊙ DISASSEMBLY

- Remove the bushing using the special tool.

 Bearing remover(20~35 mm)
: 09923-74510



⊙ CLUTCH COVER

■ OIL FILTER REPLACEMENT(Refer to page 2-10)

■ DISASSEMBLY

- Remove the circlip and right crankshaft oil seal.

 Oil seal remover : 09913-50121

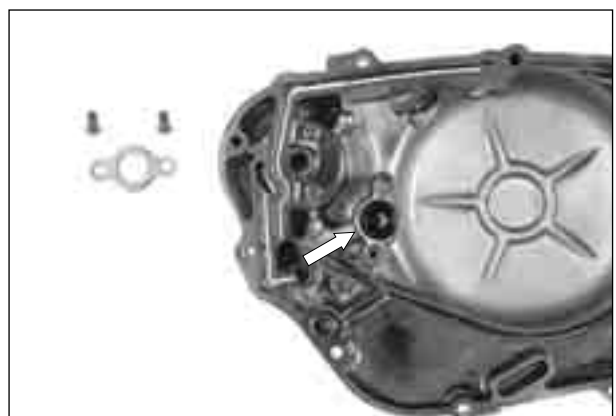

3-29 ENGINE

■ REASSEMBLY

- Drive in the oil seal using the special tool.

 **Bearing installer : 09913-75820**

- Install the circlip.



⊙ CLUTCH DRIVE PLATES

Measure the thickness and claw width of the clutch drive plates using vernier calipers. If a clutch drive plate is not within the service limit, replace the clutch plates as a set.

Clutch drive plate thickness	Standard
	2.9~3.1 mm (0.114~0.122 in)

Clutch drive plate thickness	Service limit
	2.6 mm (0.102 in)

Clutch drive plate claw width	Standard
	11.8~12.0 mm (0.465~0.472 in)

Clutch drive plate claw width	Service limit
	11.0 mm (0.433 in)

 **Vernier calipers : 09900-20101**

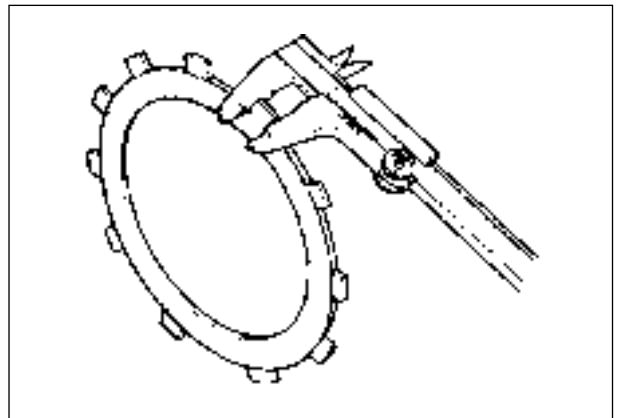
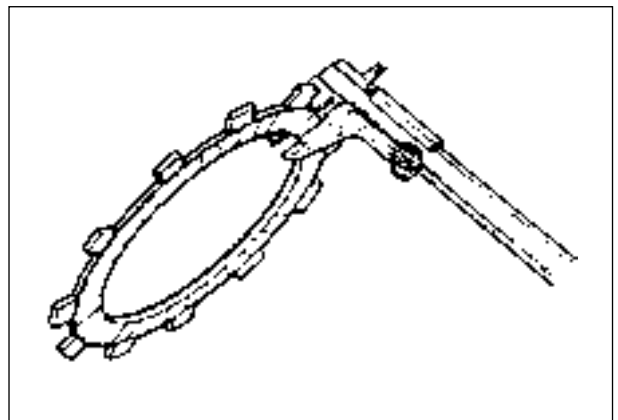

⊙ CLUTCH DRIVEN PLATES

Measure each clutch driven plate for distortion using the thickness gauge. If a clutch driven plate is not within the service limit, replace the clutch plates as a set.

Clutch driven plate distortion	Service limit
	0.1 mm (0.004 in)

 **Thickness gauge : 09900-20806**

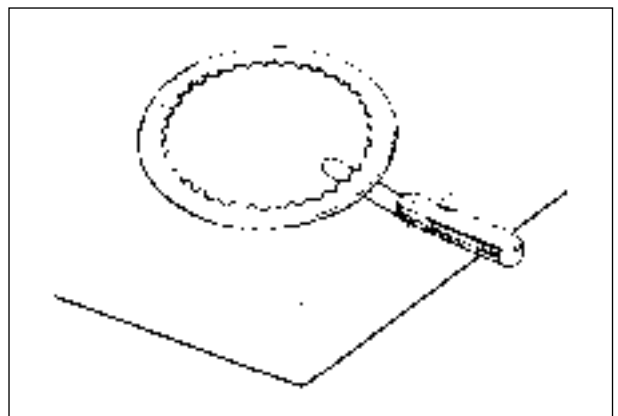

⊙ CLUTCH SPRING FREE LENGTH

Measure the free length of each clutch spring using vernier calipers. If any spring is not within the service limit, replace all of the spring.

Clutch spring free length	Service limit	
	『Comet 250』	『Comet 125』
	36.2 mm (1.43 in)	29.5 mm (1.16 in)

 Vernier calipers : 09900-20101

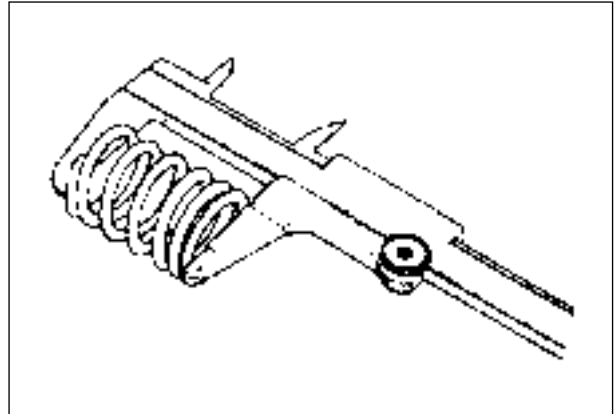

⊙ CLUTCH RELEASE BEARING

Inspect the clutch release bearing for any abnormality, especially cracks. When removing the bearing from the clutch, decide whether it can be reused or if it should be replaced.

Smooth engagement and disengagement of the clutch depends on the condition of this bearing.

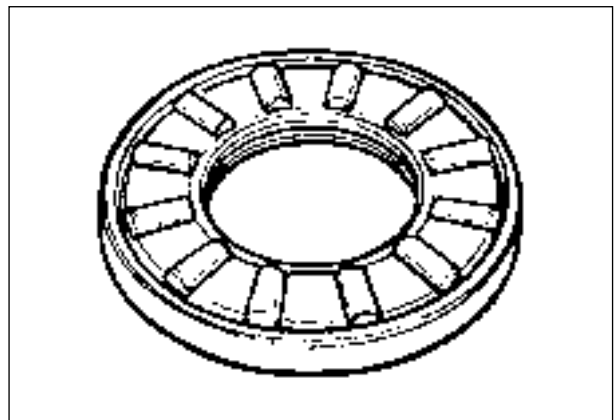

⊙ PRIMARY DRIVEN GEAR

Inspect the primary driven gear bearing for any damage. If any abnormal condition are found, replace the primary driven gear.



⊙ OIL PUMP

Turn the oil pump shaft and check that rotation is smooth. If any abnormal condition is found, replace the oil pump with new one.



⊙ **GEARSHIFT SHAFT**

Disassemble and reassemble the gearshift shaft as shown in right picture.

⊙ **TRANSMISSION**

■ **INSPECTION**

★ **GEAR-SHIFTING FORK**

Using a thickness gauge, check the clearance between in the groove of its gear and shifting fork.

The clearance for each of the three shifting forks plays an important role in the smoothness and positiveness of shifting action.

If the clearance checked is noted to exceed the limit specified, replace the fork or its gear, or both.

	Standard	Service limit
Shift fork-groove clearance	0.10~0.30 mm (0.004~0.012 in)	0.5 mm (0.020 in)

 **Thickness gauge : 09900-20806**
Vernier calipers : 09900-20101

Shift fork groove width	Standard	
	『Comet 250』	『Comet 125』
NO.1 & NO.2	5.0~5.1 mm (0.197~0.201 in)	5.0~5.1 mm (0.197~0.201 in)
NO.3	5.0~5.1 mm (0.197~0.201 in)	5.5~5.6 mm (0.217~0.221 in)

Shift fork thickness	Standard	
	『Comet 250』	『Comet 125』
NO.1 & NO.2	4.8~4.9 mm (0.189~0.193 in)	4.8~4.9 mm (0.189~0.193 in)
NO.3	4.8~4.9 mm (0.189~0.193 in)	5.3~5.4 mm (0.209~0.213 in)

■ **REASSEMBLY**

Assemble the countershaft and drive shaft in the reverse order of disassembly. Pay attention to following points :

NOTE

Before installing the gears, coat lightly engine oil to the driveshaft and countershaft.

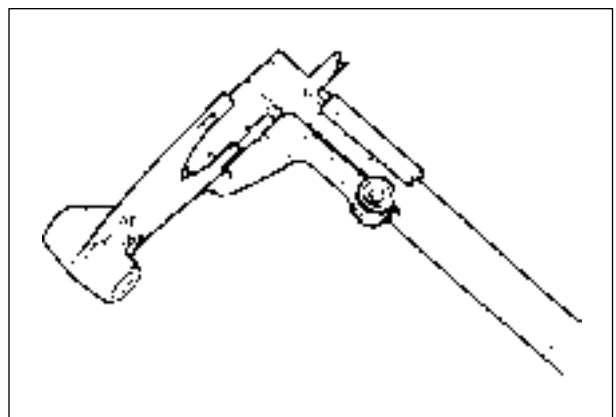
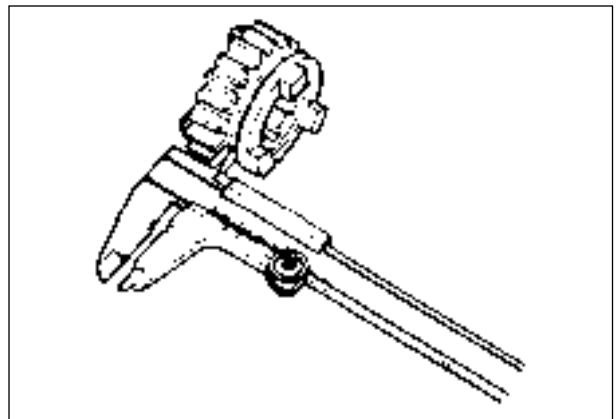
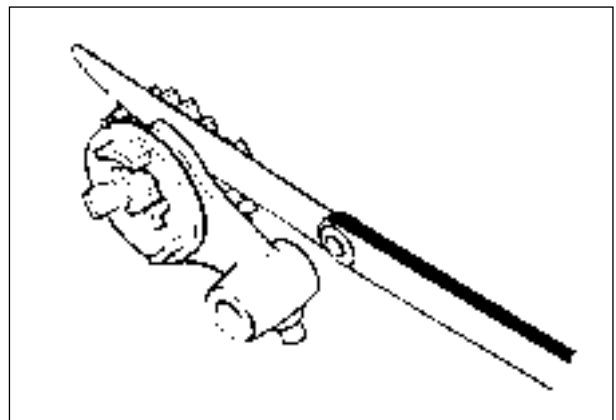

⚠ CAUTION

- ❖ Never reuse a circlip. After a circlip has been removed from a shaft, it should be discarded and a new circlip must be installed.
- ❖ When installing a new circlip, care must be taken not to expand the end gap larger than required to slip the circlip over the shaft.
- ❖ After installing a circlip, always ensure that it is completely seated in its groove and securely fitted.

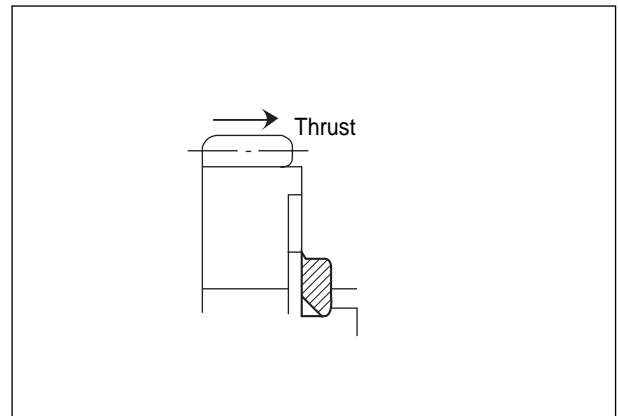

- When installing a new circlip, pay attention to the direction of the circlip. Fit it to the side where the thrust is as shown in figure.

■ TRANSMISSION GEARS AND RELATED PARTS

『Comet 250』

Thickness for washers, circlips and spacers

- Ⓐ 1.0mm Ⓓ 1.0mm
- Ⓑ 1.2mm Ⓔ 1.0mm
- Ⓒ 0.5mm

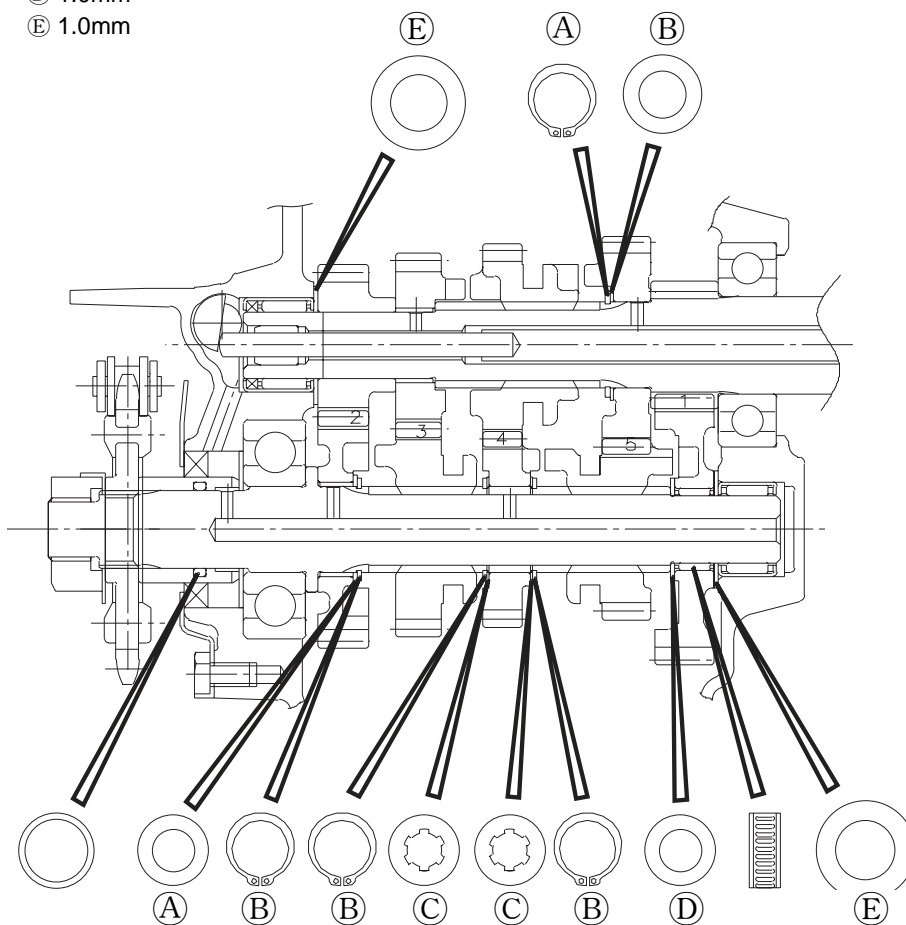

『Comet 125』

Thickness for washers, circlips and spacers

- Ⓐ 1.2mm Ⓓ 6.0mm
- Ⓑ 0.5mm Ⓔ 1.0mm
- Ⓒ 1.0mm

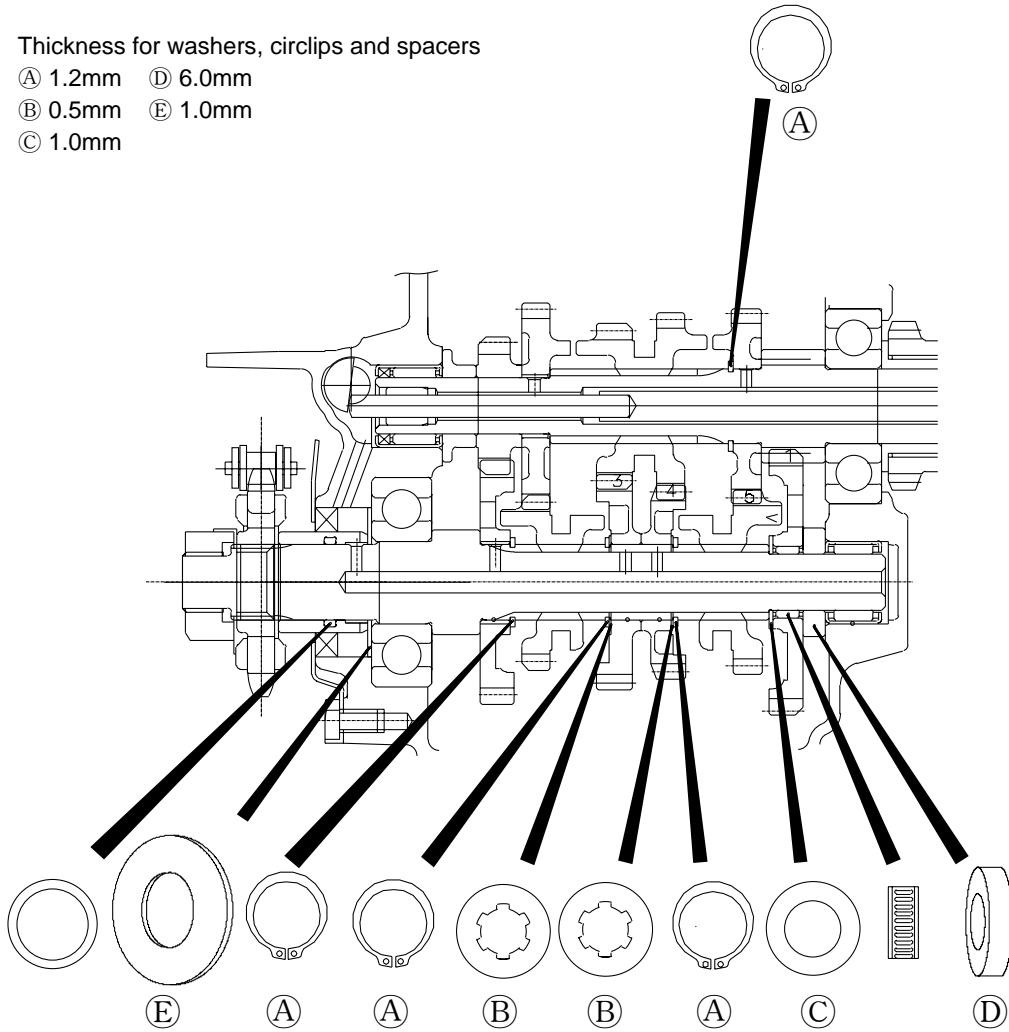

⊙ **CRANKCASE**

■ **BEARING INSPECTION**

Rotate the bearing inner race by finger to inspect for abnormal play, noise and smooth rotation while the bearings are in the crankcase.

Replace the bearing in the following procedure if there is anything unusual.

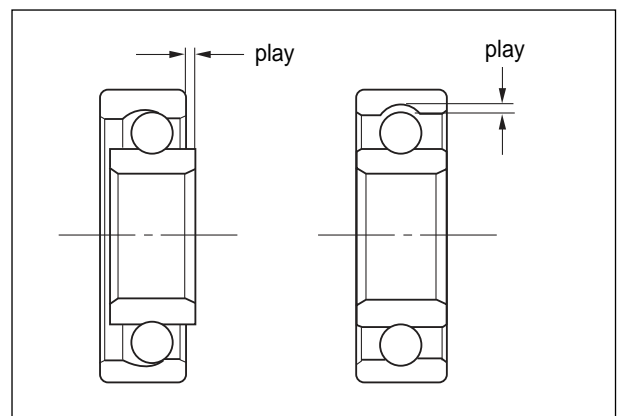

■ DISASSEMBLY

★ RIGHT CRANKCASE BEARING

- Remove the bearing retainer.



- Remove the bearings ① and ②.

TOOL Bearing remover(17 mm) : 09923-73210
TOOL Bearing remover(20~35 mm) : 09923-74510

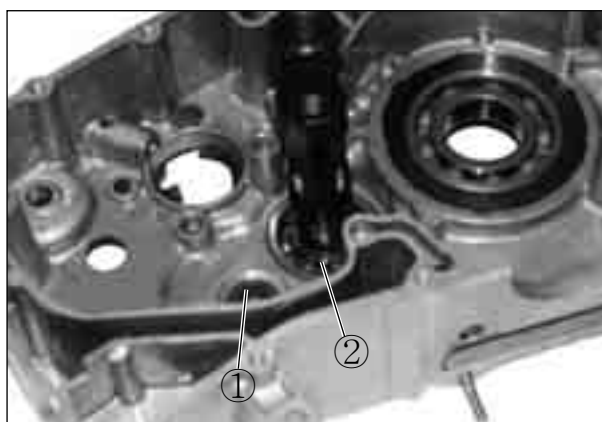

- Remove the bearing ③.

TOOL Bearing installer : 09913-76010

⚠ CAUTION

The removed bearing should be replace with a new one.

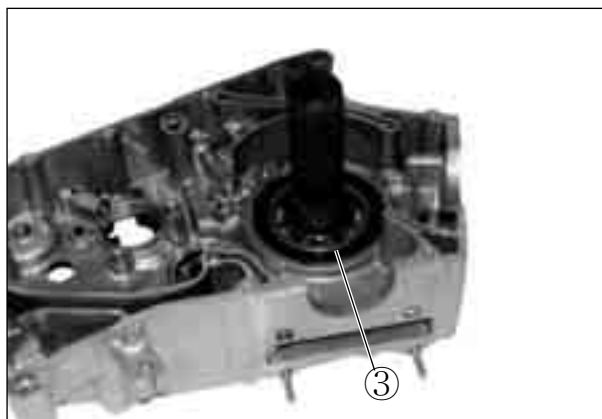

★ LEFT CRANKCASE BEARING

- Remove the oil seals ④ and ⑤.

TOOL Oil seal remover : 09913-50121

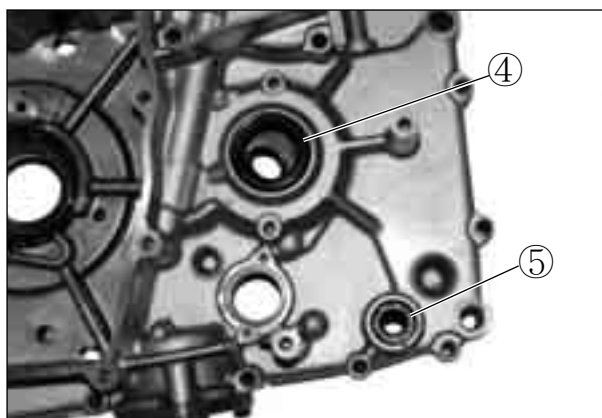

3-35 ENGINE

- Remove the bearing retainer.



- Remove the bearings ①, ② and ③.

 **Bearing remover(17 mm) : 09923-73210**
Bearing remover(20~35 mm) : 09923-74510

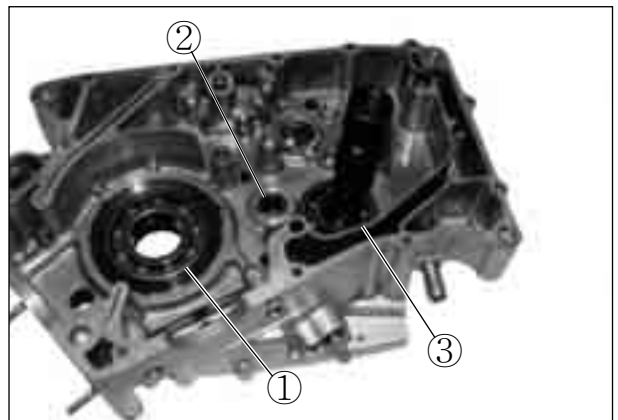

■ REASSEMBLY

★ RIGHT CRANKCASE BEARING

- Drive in the bearings ④, ⑤ and ⑥.

 **Bearing installer : 09913-70122**
Bearing installer : 09913-76010

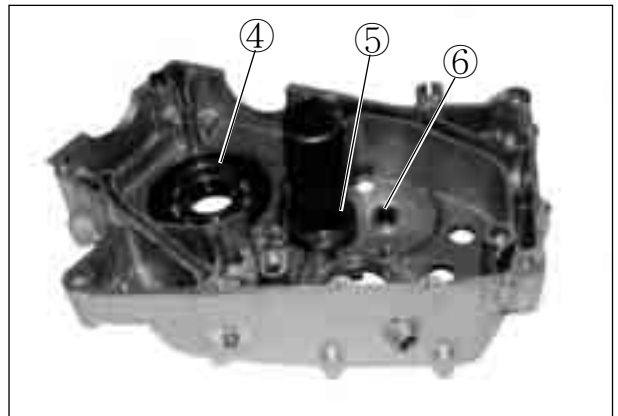

★ LEFT CRANKCASE BEARING

- Drive in the bearings ⑦, ⑧ and ⑨.

 **Bearing installer : 09913-70122**
Bearing installer : 09913-76010

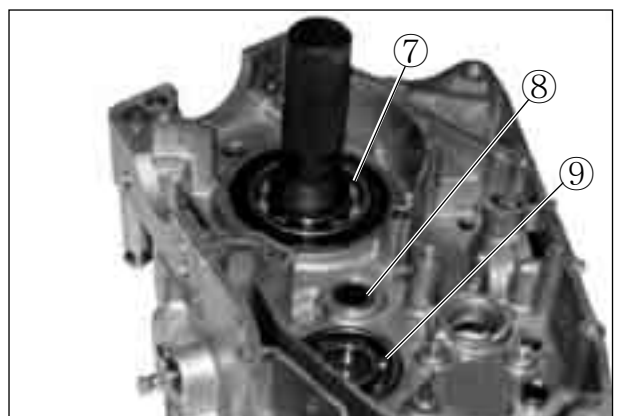

- Install the oil seals ① and ②.
- Apply SUPER GREASE “A” on the lip of oil seal.

 SUPER GREASE “A”

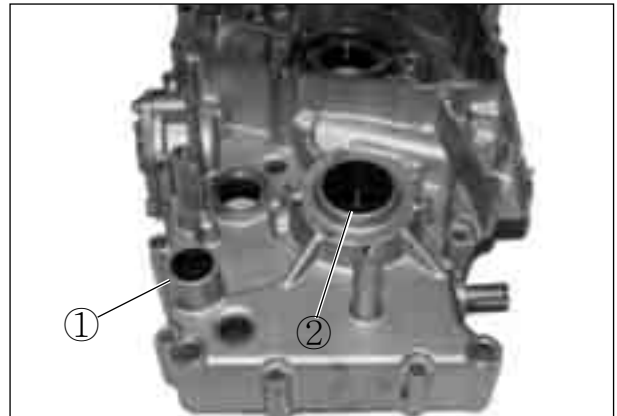

ENGINE REASSEMBLY

The engine reassembly can be performed in the reverse order of disassembly procedures. However, the following points must be observed in the reassembly operation.

CAUTION

Make sure to coat the rotating and sliding sections with engine oil.

⊙ CRANKSHAFT

- Using the special tool, press in the crankshaft into the left crankcase.

 Crankshaft installer : 09910-32812
Conrod holder : 09910-20115

CAUTION

Never fit the crankshaft into crankcase by striking it with a plastic hammer.
Always use the special tool, otherwise crankshaft alignment accuracy will be affected.



⊙ TRANSMISSION

- Install the transmission.



3-37 ENGINE

⊙ GEARSHIFT CAM AND GEARSHIFT FORKS

- Install the gearshift fork NO.1 ①, NO.2 ②, and NO.3 ③.
- Install the gearshift cam ④, and gearshift fork shaft ⑤, ⑥.
- Install the oil pump idle gear shaft ⑦.

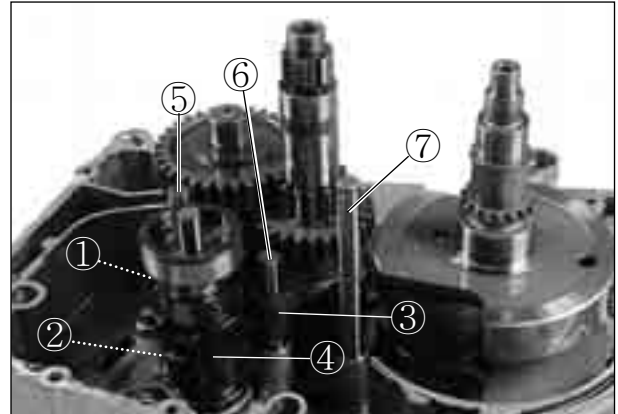

- Install the dowel pins ⑧.
- Before assembling the crankcase, apply the engine oil to each gear and bearing.



- Apply BOND “1215” to the right crankcase.

 BOND “1215”

CAUTION

- ❖ Application of BOND “1215” must be performed within a short period of time.
- ❖ Take extreme care not to let BOND “1215” enter into the oil hole or bearing.

- Install the crankcase.
- Install the crankcase bolts.

 Crankcase bolt
: 8~12 N · m(0.8~1.2 kg · m)

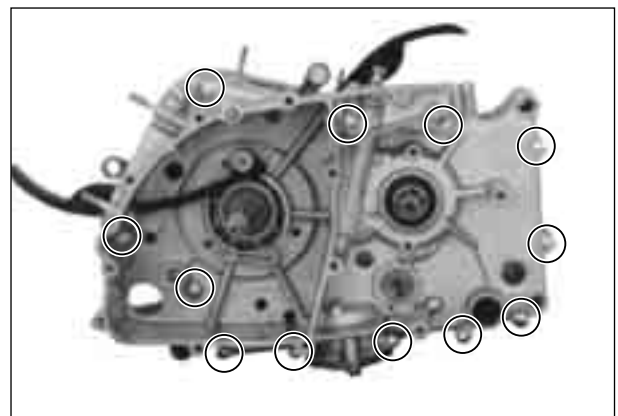

NOTE

- ❖ *After the crankcase bolts have been tightened, make sure that the crankshaft, countershaft and driveshaft rotate smoothly.*
- ❖ *If these shafts do not rotate smoothly, try to free it by tapping with a plastic hammer.*

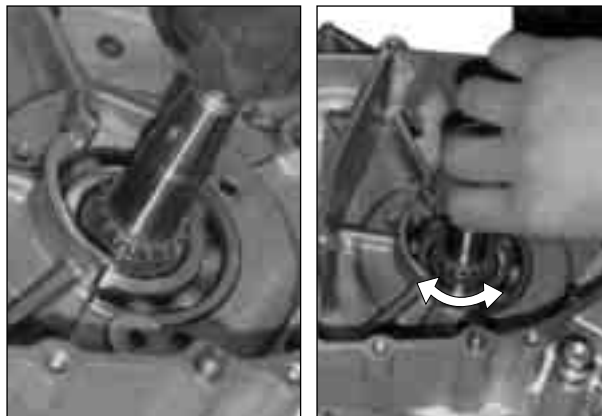

- Apply the SUPER GREASE “A” to the driveshaft O-ring and oil seal lip.
- Install the driveshaft spacer.

 SUPER GREASE “A”

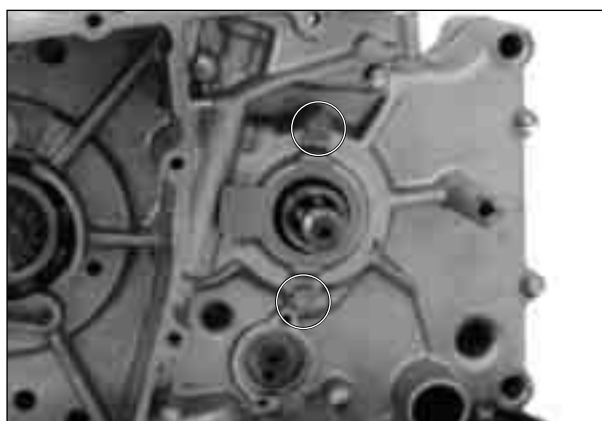

- Install the oil seal retainer.

**■ GEARSHIFT CAM DRIVEN GEAR**

- When installing the gearshift into the cam driven gear, the big shoulder **A** face toward outside as shown in figure.
- Install the cam guide and pawl lifter. When installed, apply the THREAD LOCK “1324” to the securing screw.

 **1324** THREAD LOCK “1324”

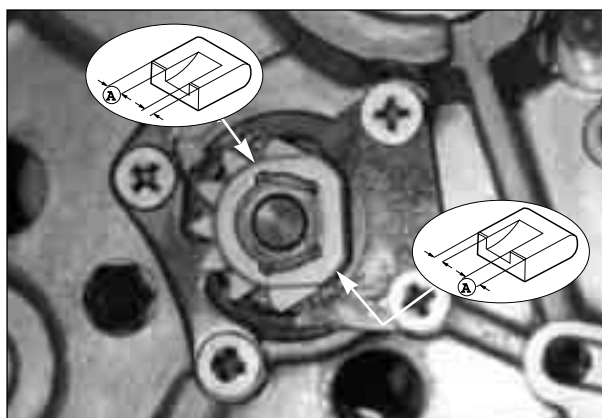

■ GEARSHIFT SHAFT

Install the gear shifting shaft. Match the center teeth of the gear on the shifting shaft with the center teeth on the shifting driven gear as shown.

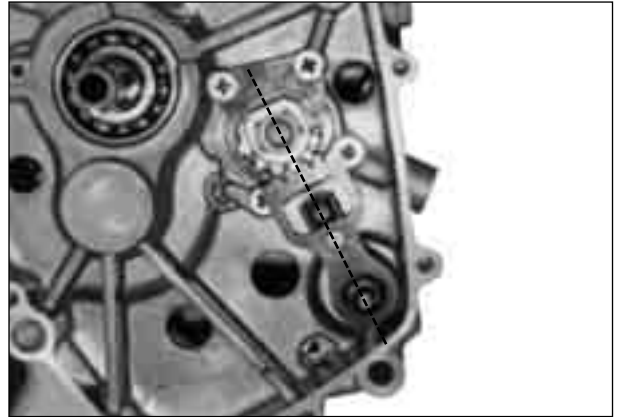

 CAUTION

After the cam driven gear, cam guide, gear shift shaft and neutral cam stopper have been fitted, confirm that gear change is normal while turning, the countshaft and driveshaft. If gear change is not obtained, it means that assembly of gears or installation of gear shifting fork is incorrect. In this case, disassemble and trace the mistake.

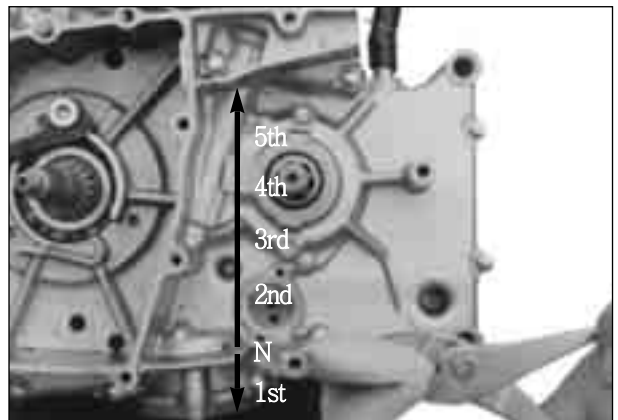

⊙ OIL PUMP

- Before installing the oil pump, apply the engine oil to the contact face of case, outer rotor, inner rotor and shaft.
- Apply a small quantity THREAD LOCK “1324” to the oil pump securing screws.

 THREAD LOCK “1324”

- Tighten the oil pump securing screws.
- Install the oil pump pin.

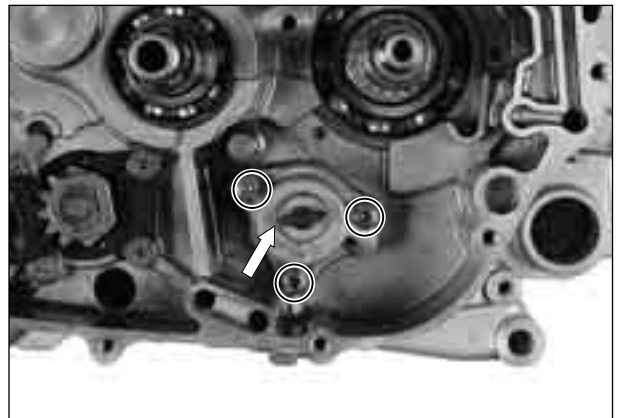

- Put in the oil pump driven gear, and install the circlip.



⚠ CAUTION

When installing the oil pump to the crankcase, turn the pump gear and check that rotation is smooth by the hand.



⊙ CAM CHAIN TENSIONER

- Install the washer ① and cam chain tensioner ②, tighten the cam chain tensioner bolt.

🔧 Cam chain tensioner bolt
: 6~8 N · m(0.6~0.8 kg · m)

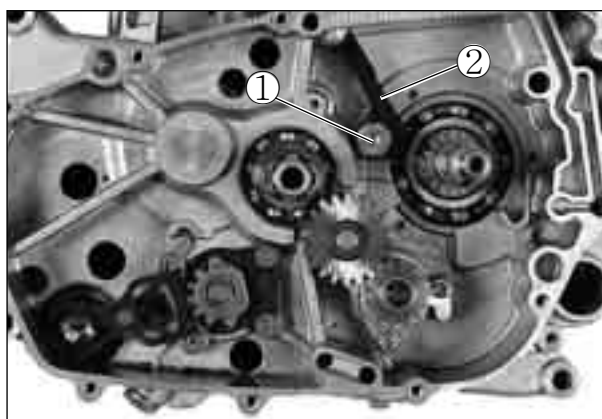

- Install the cam chain ③ and key.

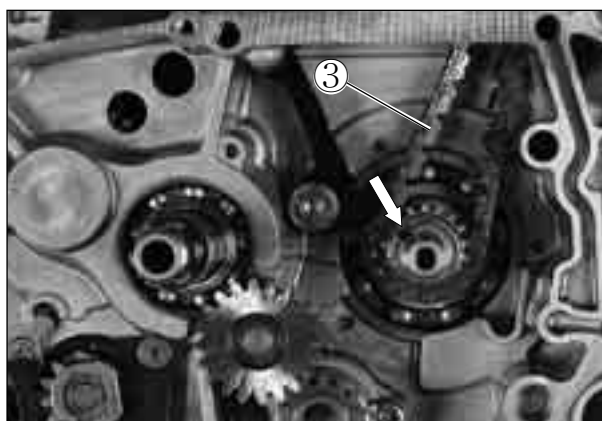

- Install the primary drive gear and NO.2 gear to the crankshaft, put in the key to the key groove.

⚠ CAUTION

When installing the NO.2 gear, install so that the mark on the gear align the key groove as shown in figure.

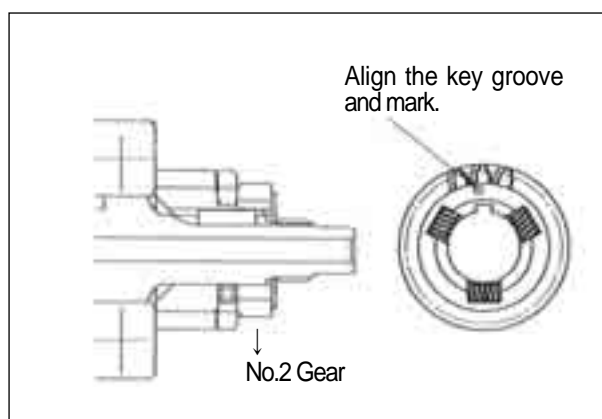

⚠ CAUTION

Pay attention to the two washer to lower end of the primary drive gear nut in times of assemblage.



- With the magneto rotor held immovable using special tool, tighten the primary drive gear nut.

 **Conrod holder : 09910-20115**

 **Primary drive gear nut**
: 40~60 N · m(4.0~6.0 kg · m)



⊙ **PRIMARY DIRVEN GEAR**

NOTE

Valve clearance should be checked when the engine is cold.

Both the intake and exhaust valves must be checked and adjusted when the piston is at Top-Dead-Center (TDC) of the compression stroke.

- Install the primary driven gear assembly.

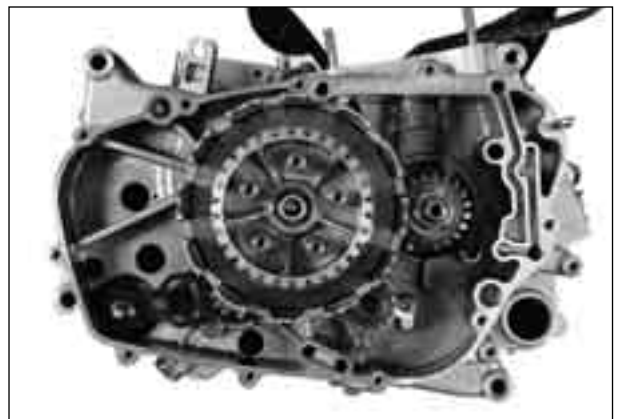

CLUTCH

- Install the clutch sleeve hub ①, lock washer ②.

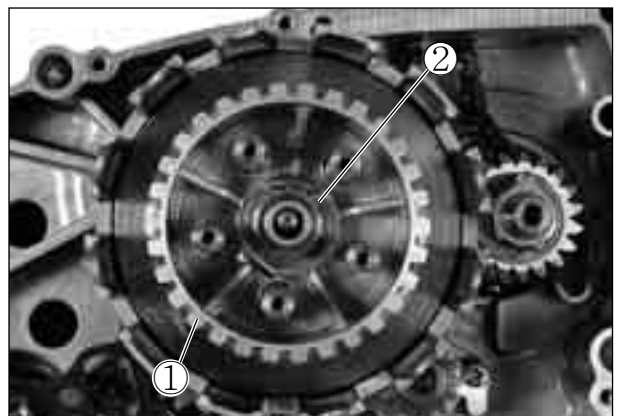

- Install the clutch sleeve hub nut, and tighten it to the specified torque using the special tool.

 **Clutch sleeve hub holder : 09920-53710**

 **Clutch sleeve hub nut**
: 30~50 N · m(3.0~5.0 kg · m)

- Bend the lock washer securely.

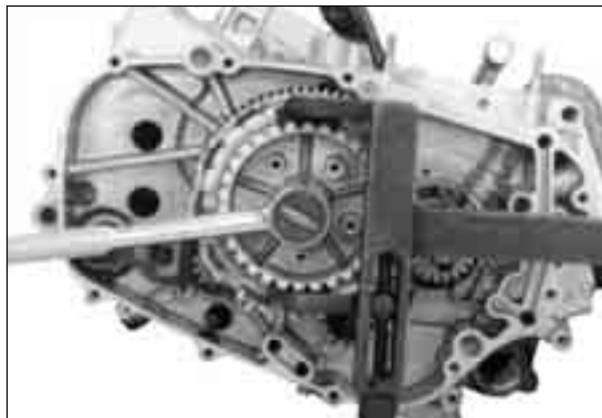

- Install the clutch drive plates and driven plates.

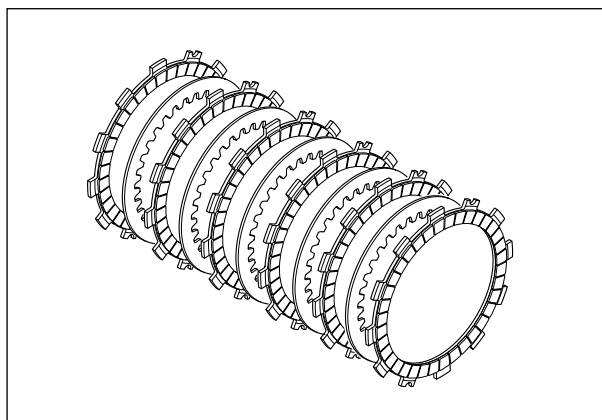

- Install the clutch release rack ①, bearing ② and washer ③.

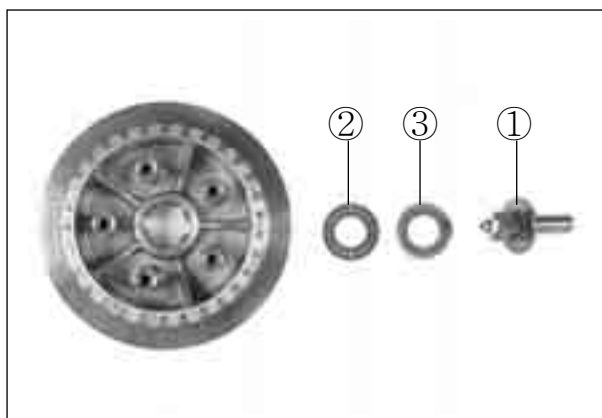

3-43 ENGINE

- Install the clutch pressure plate ①, clutch springs and clutch spring mounting bolts.
- Hold the primary drive gear nut and tighten the clutch spring mounting bolts in a crisscross pattern.

NOTE

Make sure that the clutch pressure plate is installed correctly.

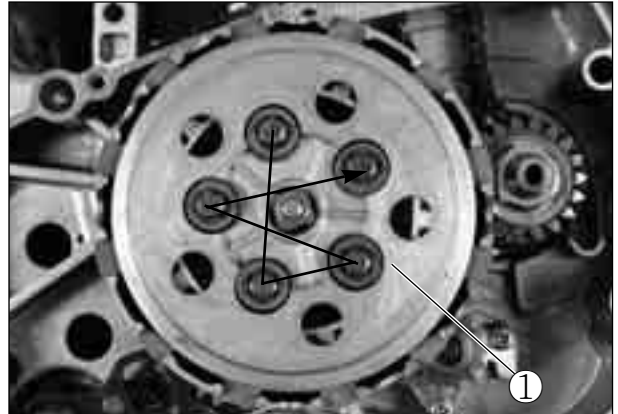

■ CLUTCH COVER

- Install the two dowel pins and new gasket ②.
- Apply engine oil to each gears, bearings and clutch plates.

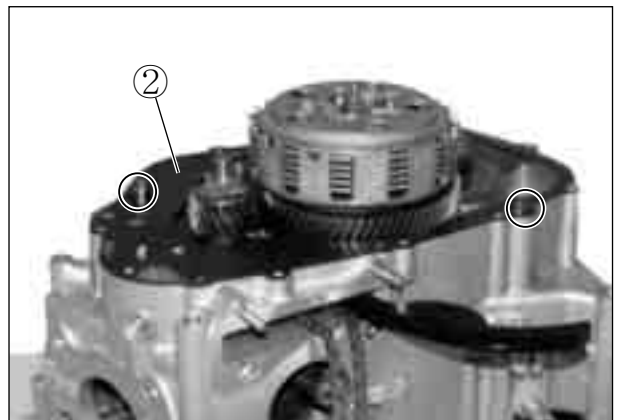

- Install the clutch cover, and tighten the clutch cover bolts securely.

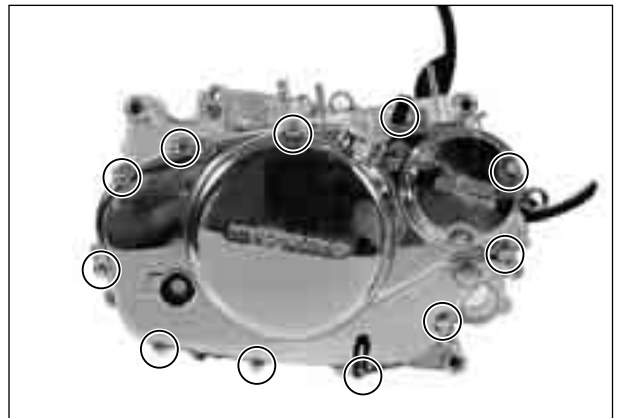

- Install the clutch release arm as following:
 - ① Turn the clutch release shaft toward (This time, mark on the shaft align outside contact line the stopper screw) the right.
 - ② Install that the cable connecting center line of the clutch release arm align matching mark rightside of the case as shown in the right figure.

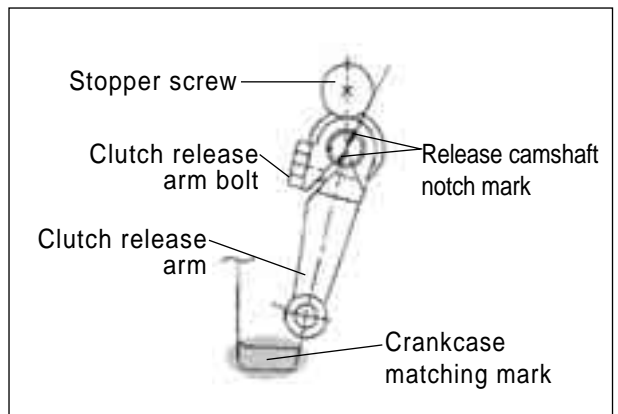

⊙ NEUTRAL CAM STOPPER

- Put in the neutral cam stopper, spring and washer, tighten the cam stopper plug to the specified torque.

 **Neutral cam stopper plug**
: 20~25 N · m(2.0~2.5 kg · m)

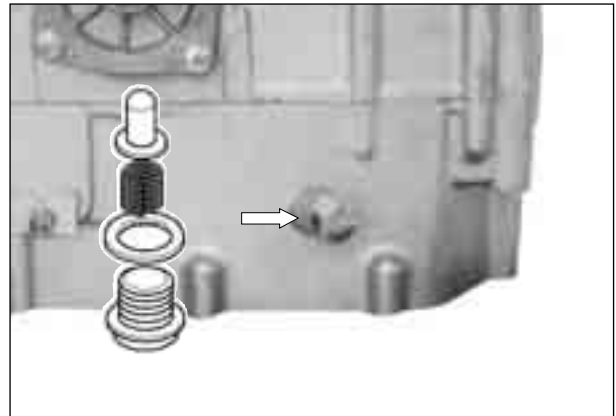

⊙ OIL DRAIN PLUG

- Tighten the oil drain plug to the specified torque.

 **Engine oil drain plug**
: 18~20 N · m(1.8~2.0 kg · m)

⊙ STATOR

- Apply a small quantity of THREAD LOCK “1324” to the threaded parts of screws.

 **THREAD LOCK “1324”**

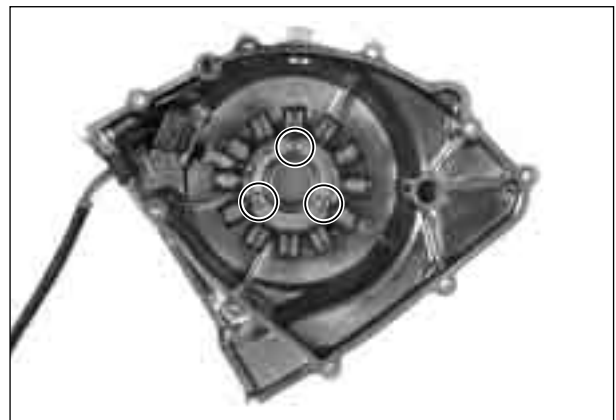

⊙ STARTER CLUTCH

- When installing the starter clutch and rotor, apply the THREAD LOCK “1324” to the bolts and tighten to the specified torque.

 **THREAD LOCK “1324”**

 **Starter clutch bolt**
: 15~20 N · m(1.5~2.0 kg · m)



⊙ MAGNETO ROTOR

- Fit the key in the key slot on the crankshaft.
- With the magneto rotor, install the starter clutch on the crankshaft.
- Apply a small quantity of THREAD LOCK “1324” to the threaded parts of crankshaft.

 **THREAD LOCK “1324”**



3-45 ENGINE

- Tighten the magneto rotor nut to the specified torque.

 **Conrod holder : 09910-20115**

 **Magneto rotor nut**
: 50~60 N · m(5.0~6.0 kg · m)

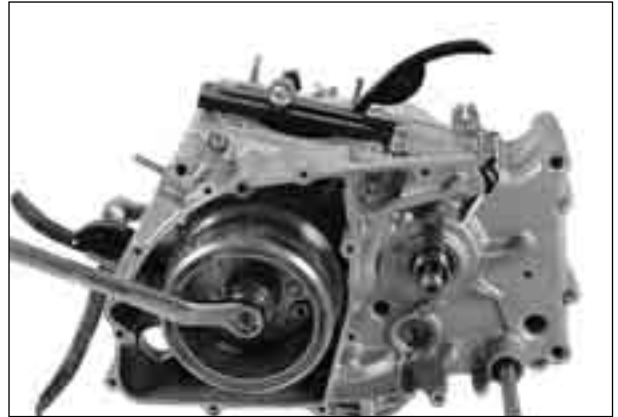

⊙ **STARTER IDLE GEAR AND MOTOR**

- Install the starter idle gear, shaft and spacer.

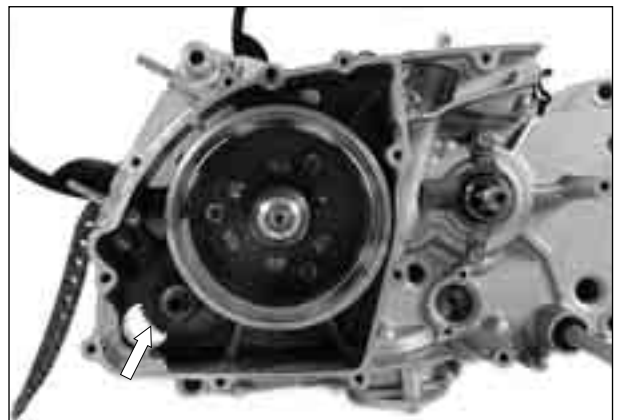

- Install the starter motor.



⊙ **MAGNETO COVER**

- Install the new gasket and dowel pin.
- Apply oil to the each gear, bearing and starter clutch.



- Install the magneto cover and tighten the magneto cover bolts.

🔧 Magneto cover bolt
: 8~12 N · m (0.8~1.2 kg · m)

⊙ **PISTON RING**

- Install the piston ring in order of oil ring, 2nd ring and 1st ring at first at the front cylinder.

⚠ CAUTION

Be careful not to cause scratch on the piston when inserting the piston ring to the piston.
Also, do not expand the piston ring more than necessary as the ring can break.

- When all the piston rings have been assembled, check that each can turn smoothly.
 - To minimize compression and oil leaks, locate each piston ring end gap in the position as shown in the right illustration
- ① 2nd ring / side rail(Upper side)
 - ② Side rail(Lower side)
 - ③ 1st ring / spacer

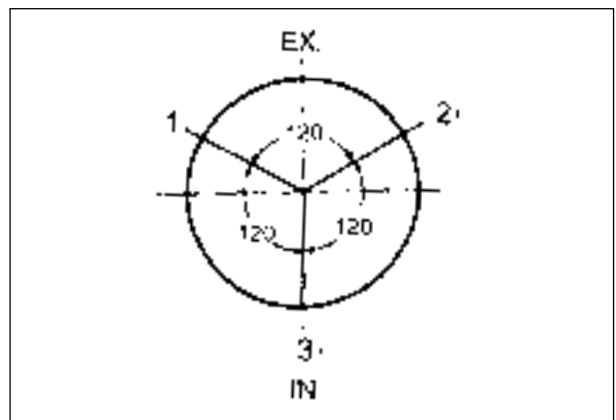
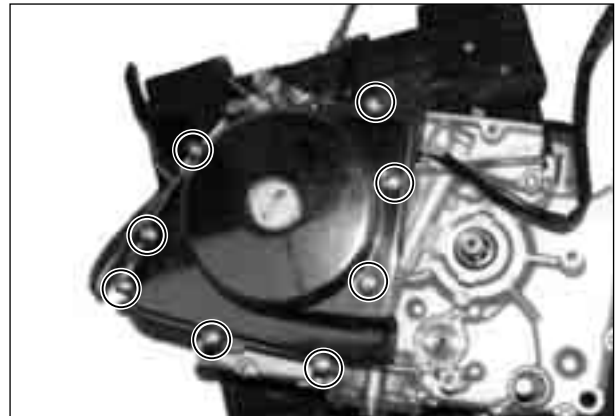
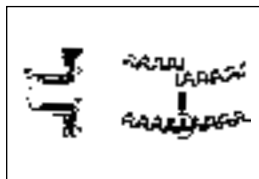

⊙ **PISTON**

- Apply the MOLY PASTE to the piston pin.

🔧 MOLY PASTE

- When installing the piston, turn the mark **A** on the piston head to exhaust side.
- After the piston pin has been inserted through the conrod, install the circlip **④**.

⚠ CAUTION

Replace the circlip with a new one.
Place a piece of rag under the piston when installing the circlip to prevent it from falling into the crankcase.

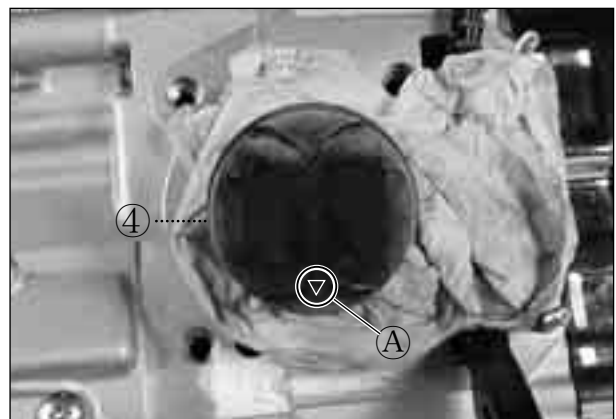

⚠ CAUTION

『Comet 125』 is equipped with the two cylinder engine, which is composed of the two piston for the front and rear.
The classification is “F” for the front and “R” for the rear.

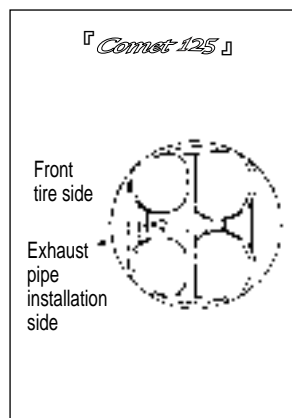

[Front piston]

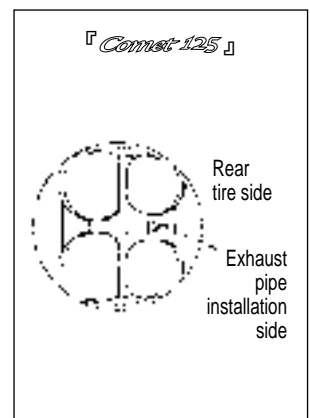

[Rear piston]

3-47 ENGINE

⊙ CYLINDER

- Apply BOND “1215” to the parting line of crankcase.

 BOND “1215”

- Place the dowel pin ① and new gasket on the crankcase.

CAUTION

Make sure to replace the gasket with a new one.

- Apply the engine oil to the conrod big end, piston and the piston rings.
- Coat the cylinder wall with oil.
- Install the cylinder.

This cylinder is different from the front and rear. With the cam chain groove of cylinder face the left side, it is the front cylinder when the cam chain tension adjuster be existed at the back.

⊙ VALVE AND SPRING

- Insert the valve, with their stems coated with MOLY PASTE.
Apply the oil to the lip of the stem seal.
- The narrow pitch side of each spring face to the head when the valve spring install. The pitch of inside spring and outside spring is changed. The pitch of spring is decreased from the upper side to the lower side.

 Valve spring compressor : 09916-14510
Valve spring compressor attachment
: 09916H35C00 (*Ⓡ Comet 250*)
Valve spring compressor attachment
: 09916H5100 (*Ⓡ Comet 125*)

⊙ CYLINDER HEAD

- Put in the valve spring and retainer, install the cotter with compressed the spring by using the valve spring compressor.

CAUTION

After installing the valve cotter, tap the valve stem end by using the plastic hammer at 2~3 times for assembly of the valve and cotter.

- Fit the cylinder head and tighten the stud bolts.

CAUTION

Pay caution to prevent the cam chain from dropping into the crankcase.

 Cylinder head stud bolt
: 21~25 N · m (2.1~2.5 kg · m)

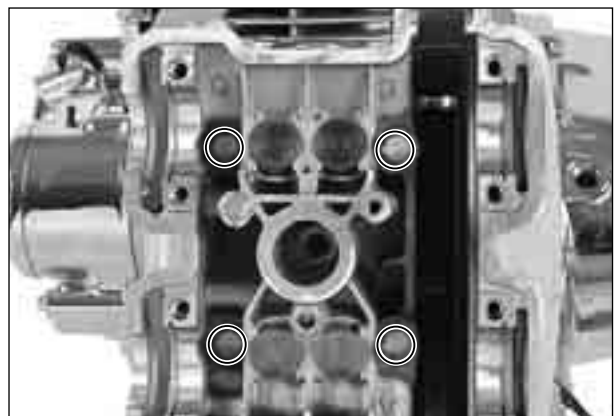
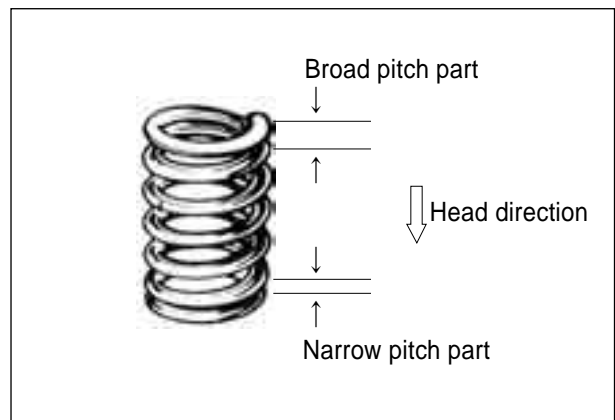
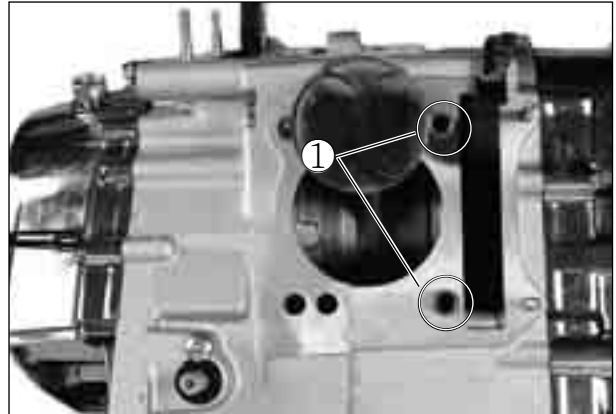

- Tighten the cylinder head base nuts.

-  **Cylinder head base nut** (『 *Comet 250* 』)
 : 7~11 N · m (0.7~1.1 kg · m)
Cylinder head base nut (『 *Comet 125* 』)
 : 15~20 N · m (1.5~2.0 kg · m)

- Tighten the two cylinder base cover nuts.

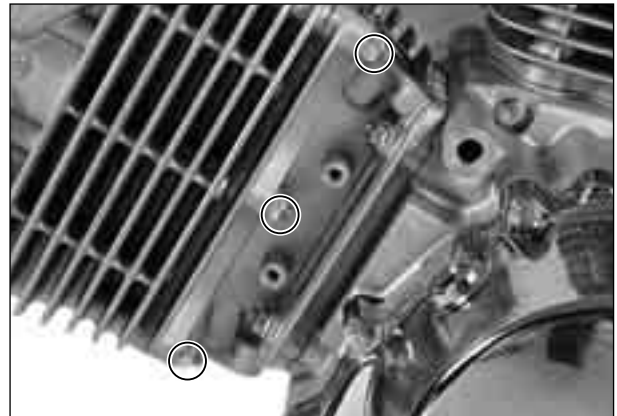
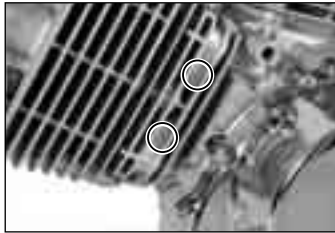

- Install the tappet and shim.

 **CAUTION**

With fit the tappet, it should be replaced if turn not smoothly by the hand.

 **CAUTION**

The tappet and shim should be installed at the original position when removed. If otherwise, it is difficult to adjust the valve clearance.

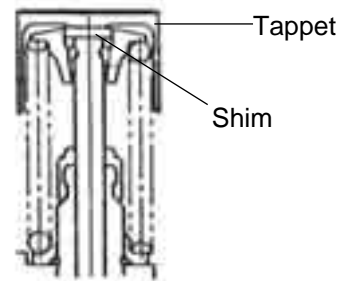

- Fit the chain guide.



[Rear Cylinder]



[Front Cylinder]

- Fit the C-ring.



⊙ **CAMSHAFT ASSEMBLY**

- Distinguish the “EX” mark for the exhaust camshaft, the “IN” mark for the intake camshaft.
Be distinguished always each camshaft what has notch at the rightside end and leftside end of it.
- When installing the camshaft and cam sprocket, apply a small quantity THREAD LOCK “1324” to the bolts and tighten with the specified torque.

 **THREAD LOCK “1324”**

 **Camshaft sprocket bolt**
: 10~12 N · m (1.0~1.2 kg · m)

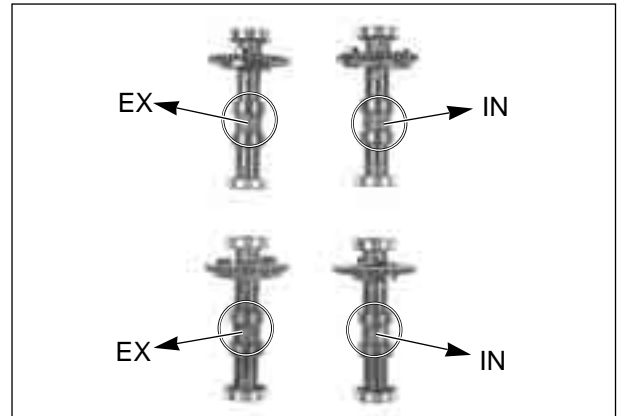

- Apply the engine oil to the camshaft bearings.

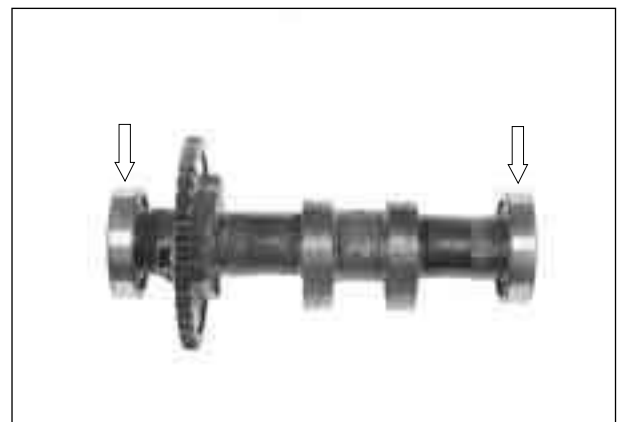

- With pull up the camshaft drive chain, align the “ | F” mark of magneto rotor into the punching mark of magneto cover to turn the crankshaft.(Front cylinder)



 **CAUTION**

When adjusting the rear cylinder, align the “ | R” mark of magneto rotor into turn counter-clockwise 285° at the postion of front cylinder.

 **CAUTION**

If turn the crankshaft without pulling up the camshaft drive chain, the chain may be fallen off between the crankcase and cam chain drive sprocket.

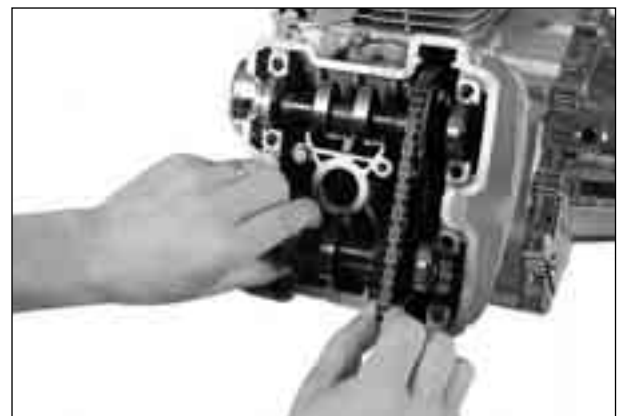

- The front cylinder head install first the exhaust camshaft, following the intake camshaft.
The rear cylinder head install first the intake as the cam chain tension adjuster exist exhaust side.

- The notch mark “—” of exhaust camshaft should be aligned with the plane of cylinder head.
At that time, the “2” arrow of exhaust camshaft sprocket should be in a vertical position to the plane of cylinder head when exhaust camshaft sprocket was geared into camchain.
- The notch mark “—” of intake camshaft should be toward the outside and aligned with the plane of cylinder head. At that time, the “3” arrow of intake camshaft sprocket should be in a vertical position to the plane of cylinder head when the intake camshaft sprocket was geared into the camchain.
- Gear into the chain at the “3” arrow of intake sprocket that count the 16th of chain roller pin from the roller pin on the “2” arrow of exhaust sprocket to the intake camshaft.

⚠ CAUTION

The rear cylinder gear into that count the 16th of chain roller pin from the “3” arrow of intake sprocket to the “2” arrow of exhaust sprocket.

- Install the “3” arrow punching mark of intake camshaft sprocket with the surface of cylinder head vertically.
- The camshaft sprocket use the intake and exhaust (the front and rear is different) in common, but use to distinguish according as installation with the camshaft.

For example,

Front exhaust : Camshaft exhaust + Front sprocket
(Install the camshaft pin at the “ E ” marking hole.)

Rear intake : Camshaft intake + Rear sprocket
(Install the camshaft pin at the “ RI ” marking hole.)

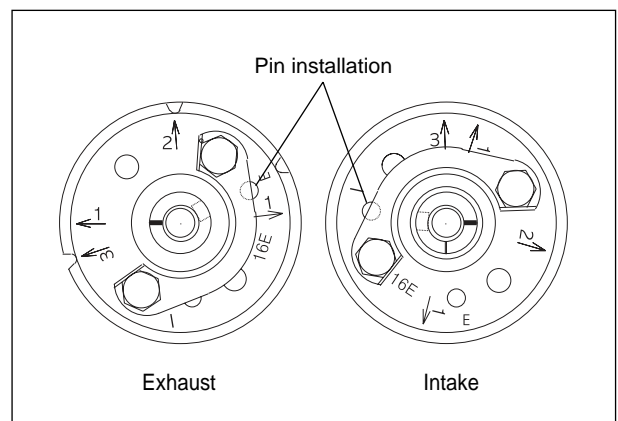
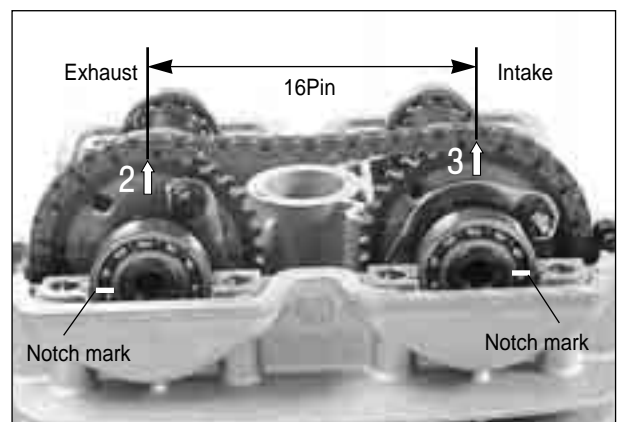
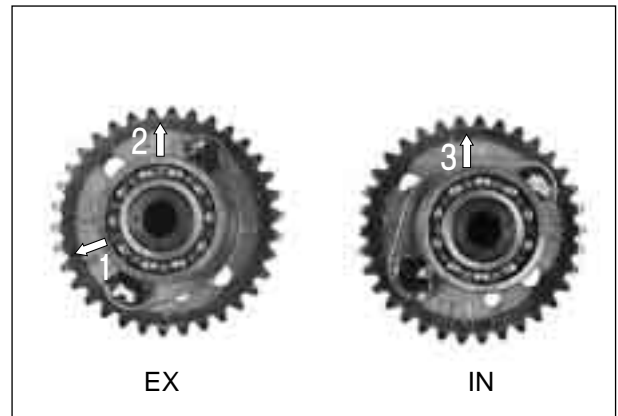

[Front Cylinder]

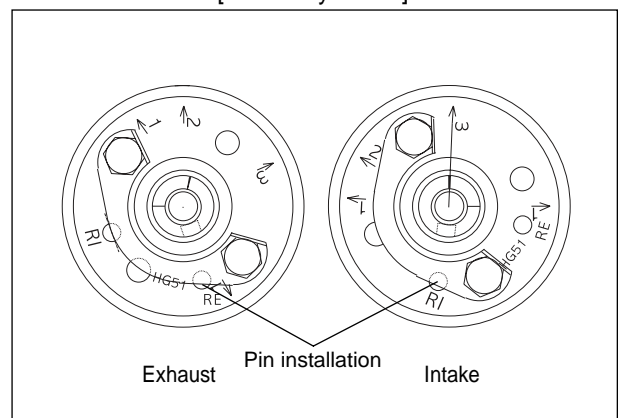

[Rear Cylinder]

⚠ CAUTION

The cam chain is installed to the all of three sprocket.
 Be sure to lie the crankshaft until the four holder and cam chain tension adjuster are installed completely.

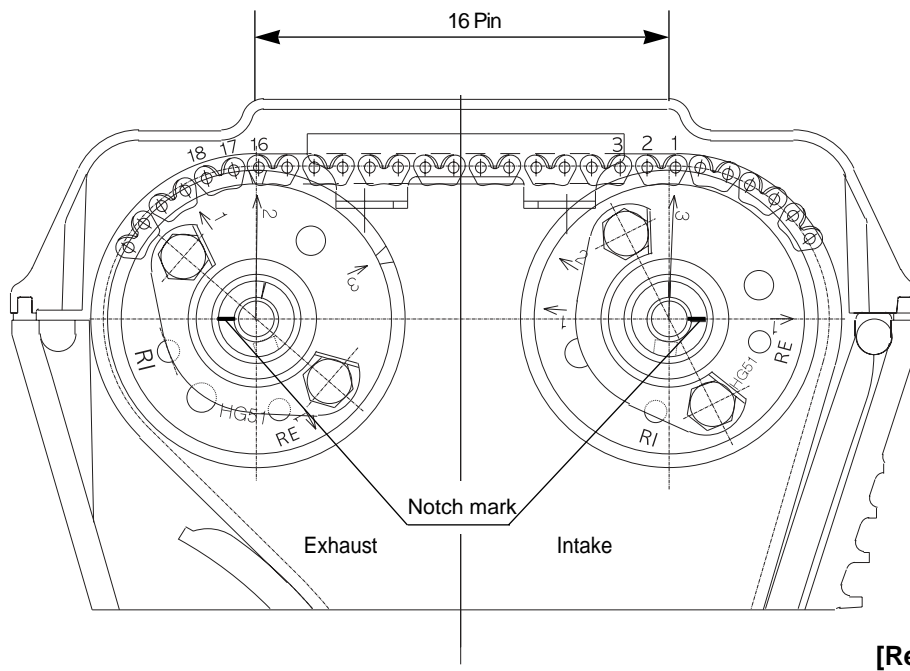
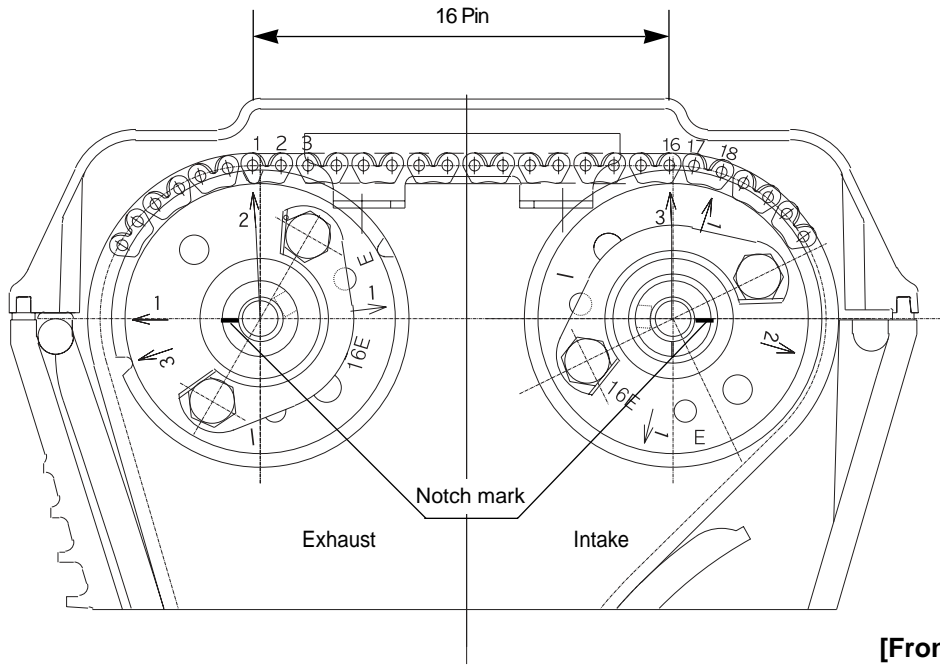

NOTE

The camshaft housing should be installed in the same manner with the front engine.

- Each camshaft housing is punched with “A” “B” “C” “D”.

Put on the housing “A” to the “A” of head surface, the housing “B” to the “B”, the housing “C” to the “C” and the housing “D” to the “D” as that “A” “B” “C” “D” is punched also to the cylinder head upper surface.

- Fix the four camshaft bearing holder and cam chain guide by tightening of the bolt in order.
Install each bolt diagonally by using the wrench pulling the shaft down.
Tighten the bolt of each camshaft bearing holder with the same torque.

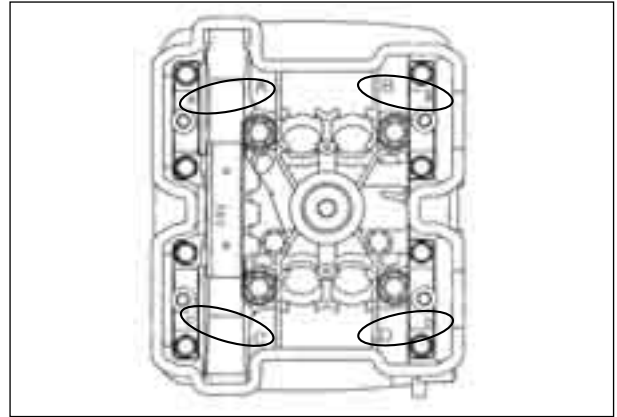

⚠ CAUTION

If get damaged the head or surface of camshaft bearing housing thrust, produce an result that the bearing housing not was tightened.

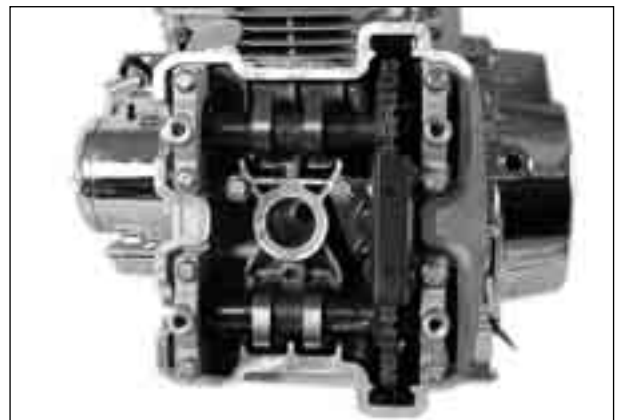

- Tighten the camshaft housing bolt with the specified torque.

⚠ CAUTION

The camshaft housing bolt is made of the special material.
This bolt is superior at the degree of hardness more than the different high tension bolt.
Pay special caution that the different type of bolt should not be used.
This bolt head is punched the “9” mark.

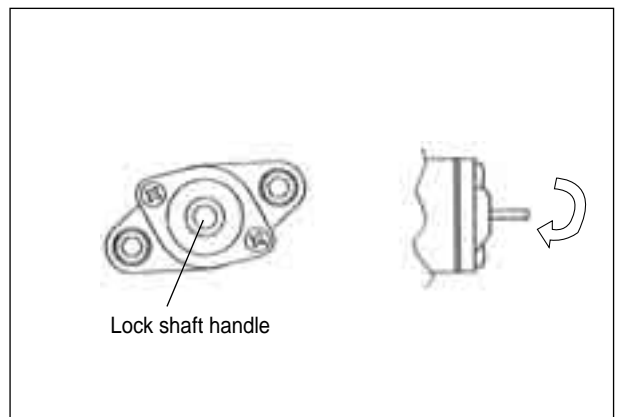

🔑 Camshaft housing bolt
: 8~12 N · m (0.8~1.2 kg · m)

- If turn the lock shaft handle in clockwise (↻) direction, the pushrod is inserted in.
Turn the mechanical spring continually until the handle is turned to the end.
- Fix the adjuster into the cylinder block.



3-53 ENGINE

- Get out the pushrod for the front to turn the lock shaft handle in counter-clockwise (↶).

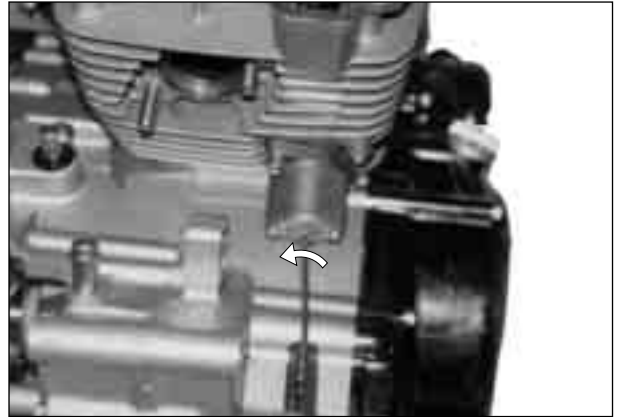

- Turn the crankshaft about 10 times counter-clockwise (↶) on the basis of the magneto rotor.
- If the valve clearance is within standard after measured the valve clearance, begin the next operation. If it is out of standard, adjust the valve clearance within standard limit after disassembled the camshaft and replaced the proper shim.



Valve clearance	Standard
IN.	0.1~0.2 mm
EX.	0.2~0.3 mm

- Adjust the valve clearance of rear cylinder with the same manner of the front cylinder. (Refer to page 2-3)



CAUTION

If you don't turn the crankshaft about 10 times before measured the valve clearance, there is no meaning in valve clearance.

- Apply BOND "1215" to the surface of cylinder head cover packing block.

 BOND "1215"

- Tighten the cylinder head cover bolts with the specified torque.

Cylinder head cover bolt

: 12~16 N · m (1.2~1.6 kg · m)

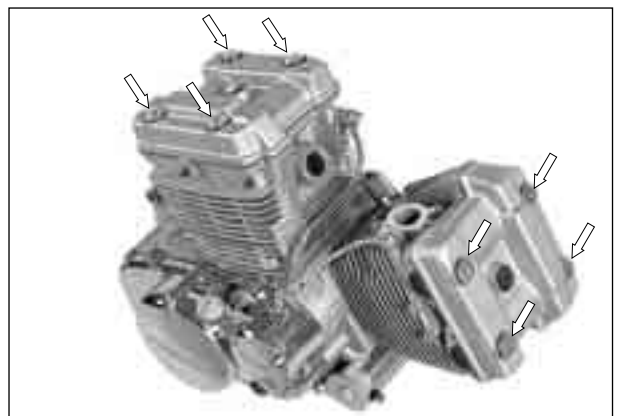

⊙ SPARK PLUG

- Install the spark plug.(Refer to page 2-5)

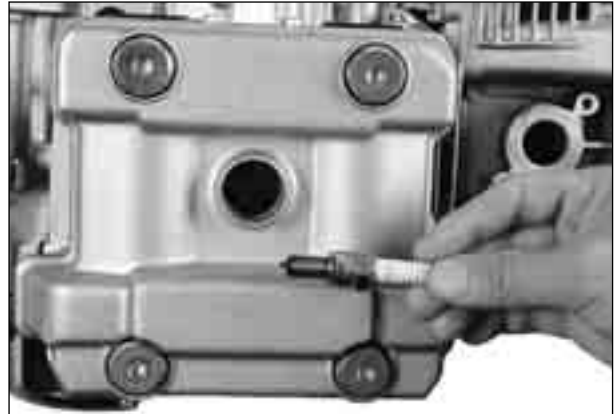

- Install the rear cylinder head and cylinder with the same manner which installed the front cylinder head and cylinder.

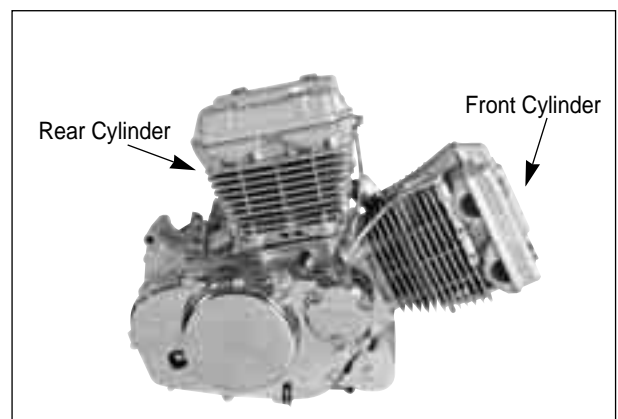
**⊙ GEAR POSITION SWITCH**

- Install the spring ① and contact ②.
- Apply SUPER GREASE "A" to the O-ring and install the gear position switch.

 SUPER GREASE "A"

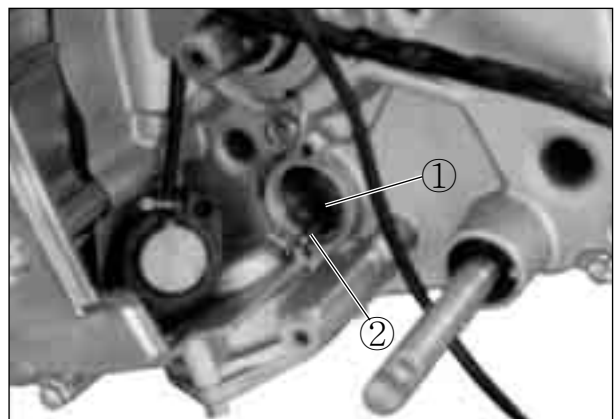

FUEL SYSTEM

CONTENTS

FUEL TANK / FUEL COCK	4- 1
FUEL PUMP	4- 2
CARBURETOR	4- 4

CAUTION

Gasoline must be handled carefully in an area well ventilated and away from fire or sparks.

FUEL TANK / FUEL COCK

⊙ REMOVAL

WARNING

Gasoline is very explosive. Extreme care must be taken.

- Remove the front seat. (Refer to page 6-1)
- Remove the fuel tank mounting bolt, and take off the hooks.
- Disconnect the fuel hose ① and remove the fuel tank.

- Remove the fuel cock.

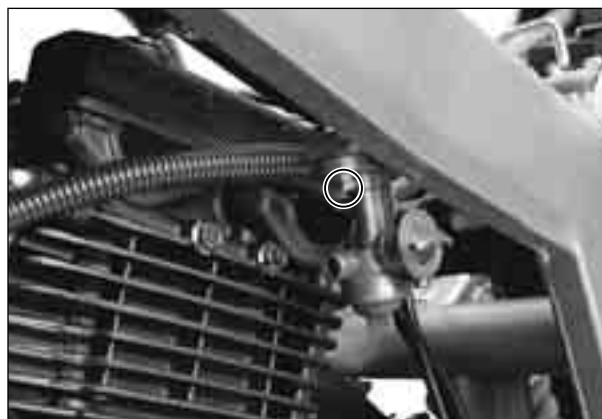
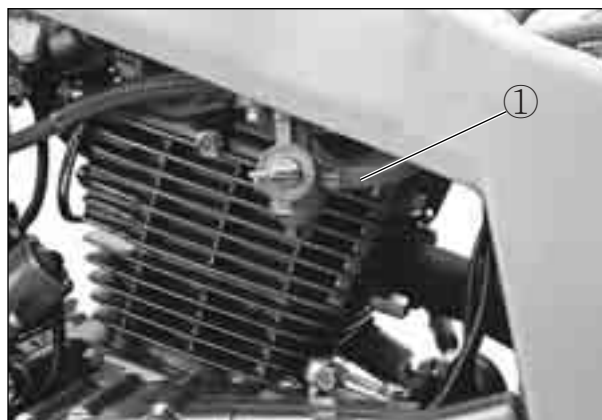

FUEL PUMP (『 Comet 250 』)

REMOVAL

- Remove the front seat and fuel tank.
- Turn the fuel cock to “OFF”.
- Disconnect the fuel hoses ①, ②.
- Remove the fuel pump mounting bolts.
- Remove the fuel pump lead wire coupler .

INSPECTION

WARNING

Gasolin is very explosive. Extreme care must be taken.

- Disconnect the fuel hose ①, connect the suitable hose and insert the free end of the hose into a receptacle.

Check the fuel flow when starting the engine for few seconds by pressing the starter switch.

If the fuel flow is not found, check the fuel cock.

If the fuel cock and hoses are not fault, replace the fuel pump. (Refer to page 5-21)

REASSEMBLY

Carry out the assembly procedure in the reverse order of disassembly.

- Connect the fuel pump lead wire coupler.
- Tighten the fuel pump mounting bolts.
- Connect the fuel hoses ①, ② securely.

FUEL HOSE ROUTING :

Fuel hose ① (To fuel cock)

Fuel hose ② (To carburetor)

FUEL PUMP RELAY

- Remove the fuel pump relay ③ mounting bolts and coupler.
- Disconnect the fuel hose ②, and check the fuel flow when starting the engine for few seconds by pressing the starter switch.
- If the fuel pump are not fault, check the fuel pump relay. (Refer to page 5-21)

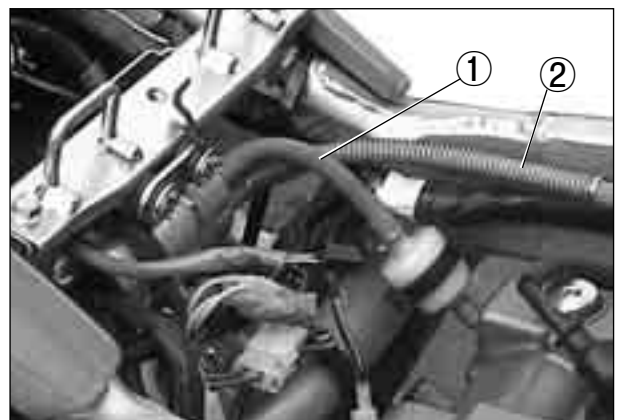

FUEL PUMP (『 Comet 125 』)

⊙ REMOVAL

- Remove the front seat and fuel tank.
- Turn the fuel cock to “OFF”.
- Disconnect the fuel hoses ①, ② and vacuum hose ③.

⊙ INSPECTION

⚠ WARNING

Gasolin is very explosive. Extreme care must be taken.

- Disconnect the fuel hose ①, connect the suitable hose and insert the free end of the hose into a receptacle.

Check the fuel flow when starting the engine for few seconds by pressing the starter switch.

If the fuel flow is not found, check the fuel cock.

If the fuel cock and hoses are not fault, replace the fuel pump.

⊙ REASSEMBLY

Carry out the assembly procedure in the reverse order of disassembly.

- Tighten the fuel pump mounting bolts.
- Connect the fuel hoses ①, ② and vacuum hose ③ securely.

FUEL HOSE ROUTING :

Fuel hose ① (To fuel cock)

Fuel hose ② (To carburetor)

Vacuum hose ③ (To intake pipe).

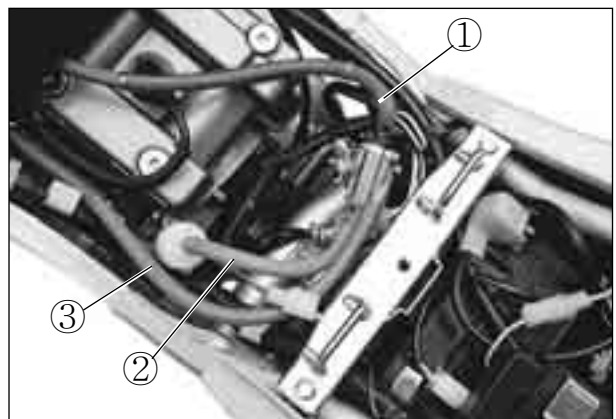

CARBURETOR

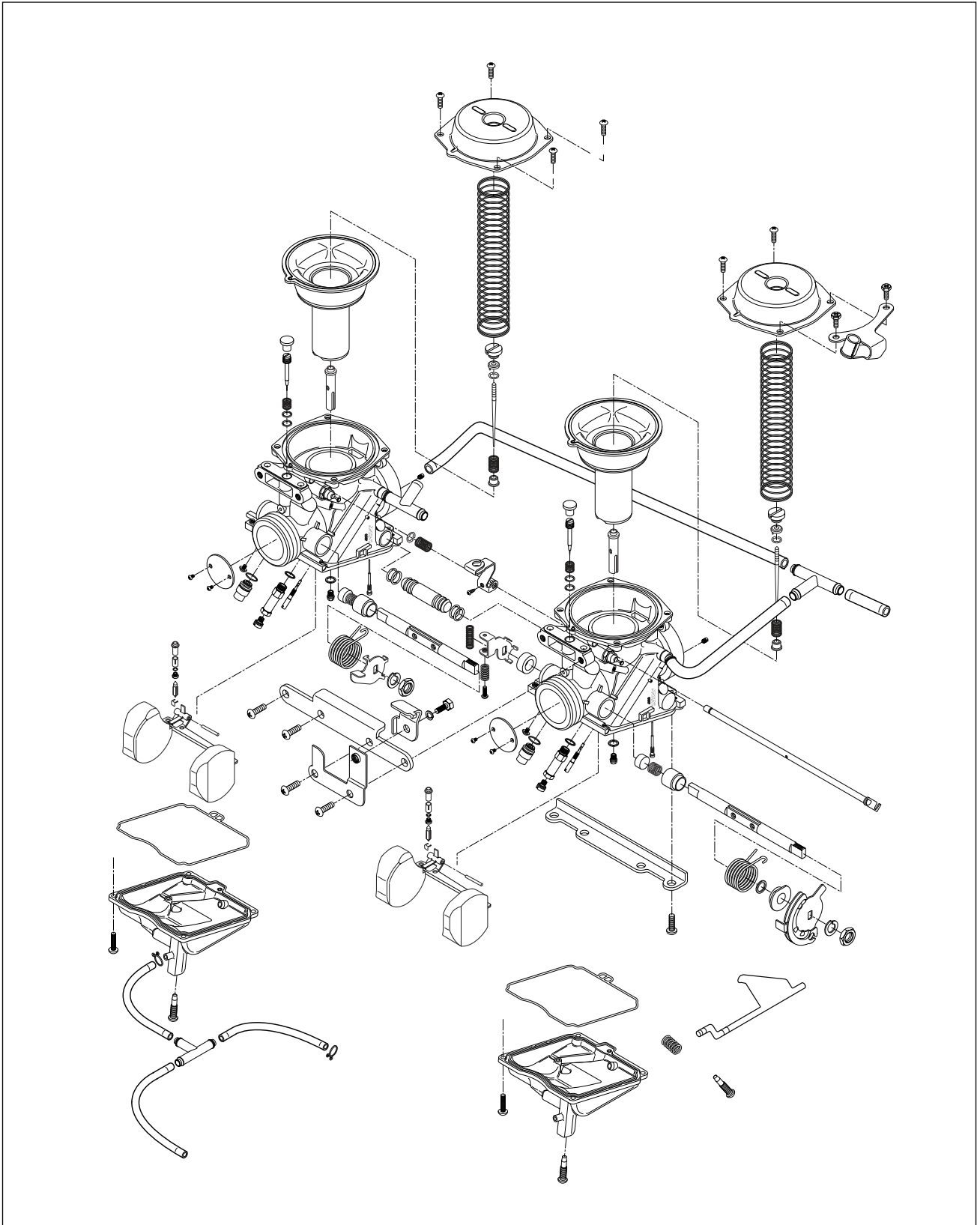

4-5 FUEL SYSTEM

⊙ LOCATION OF CARBURETOR I.D. NO.

The carburetor I.D. is stamped on the location on the carburetor as shown in the right photo.

⊙ REMOVAL

- Remove the fuel tank. (Refer to page 4-1)
- Remove the fuel hose.



- Remove the throttle cables ① and choke cable ②.
- Loosen the clamp screw and remove the carburetor.

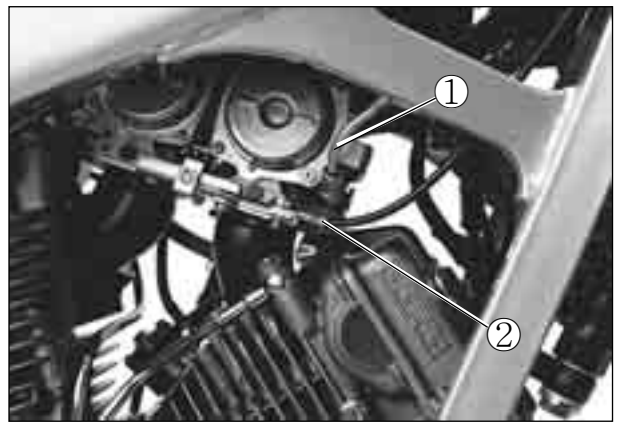

⊙ DISASSEMBLY

- Remove the diaphragm cover ③.

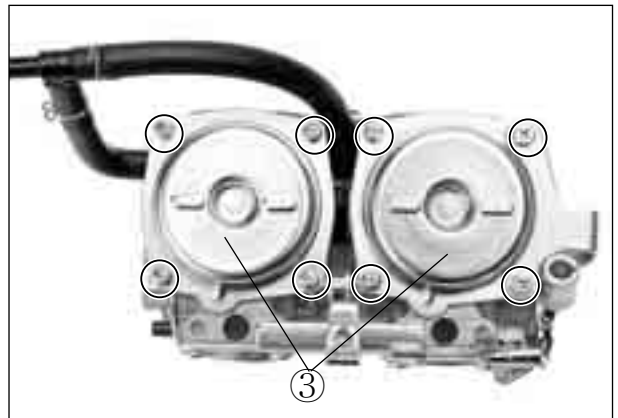

- Remove the spring ④ and piston valve ⑤ along with diaphragm ⑥.

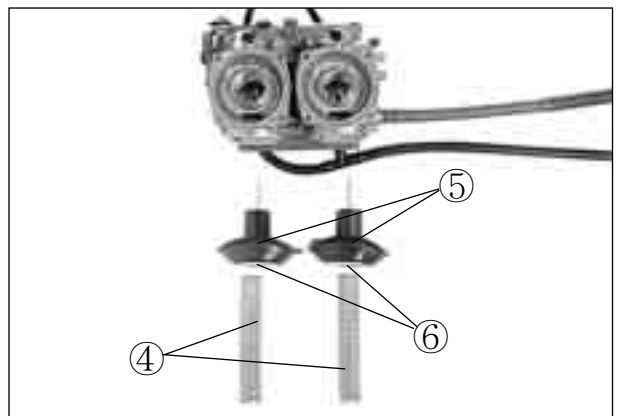

- Remove the jet needle cap ①, spring ②, retainer ③, and jet needle ④.

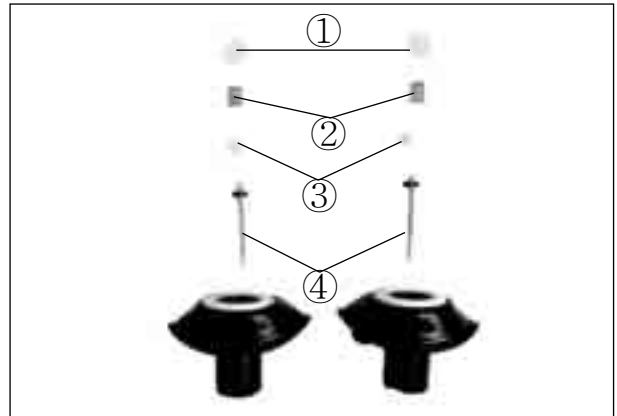

- Remove the float chamber body ⑤.

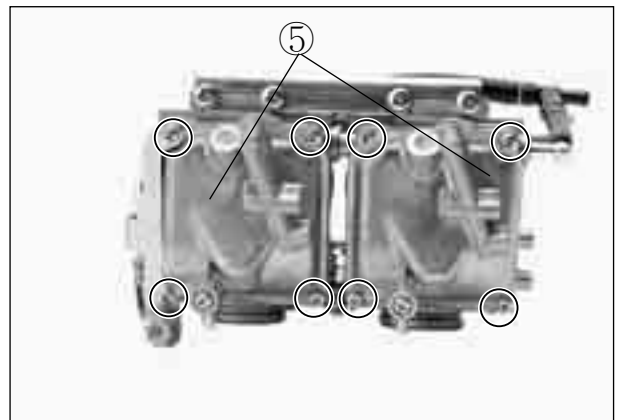

- Remove the float assembly ⑦ along with the needle valve ⑥ by removing the pin.

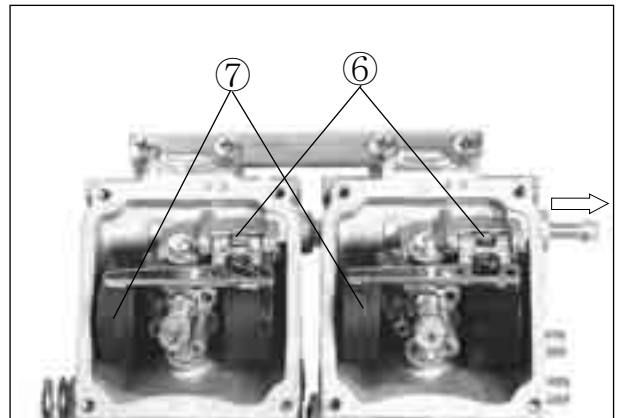

- Remove the valve seat ⑧.
- Remove the main jet ⑨, jet holder ⑩ and pilot jet ⑪.

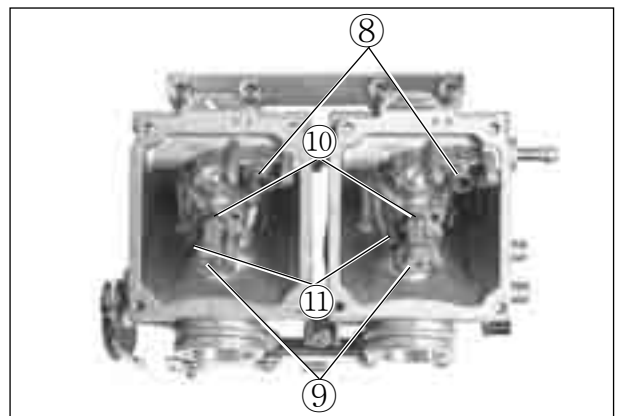

4-7 FUEL SYSTEM

- Remove the throttle cable bracket ①.

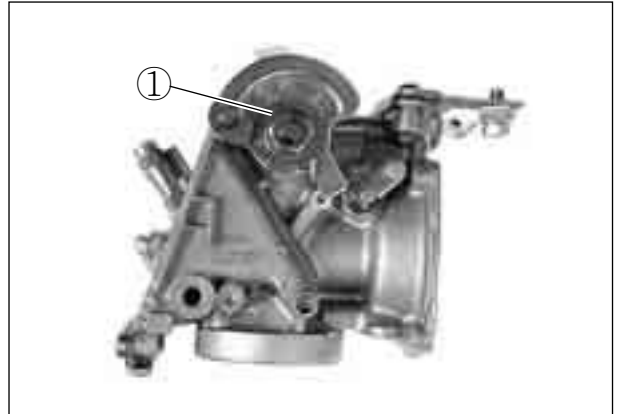

- Remove the pilot screw ② with count and tighten the number of turn.

NOTE

Record the number of turn for the pilot screw when install to confer.

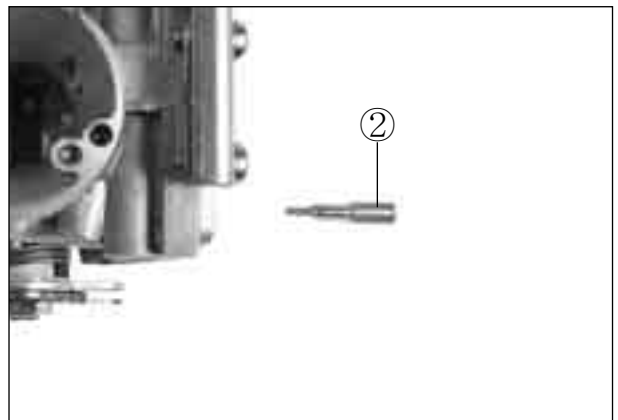

⊙ INSPECTION

Check the following parts for damage and clogging.

- | | |
|---------------------|---------------------------|
| • Pilot jet | • Piston valve |
| • Main jet | • Starter jet |
| • Main air jet | • Gaskets and O-rings |
| • Pilot air jet | • Pilot outlet and bypass |
| • Needle jet holder | • Float |
| • Needle valve | • Jet needle |
| • Valve seat | |

If any abnormal condition is found, wash the part clean.
If damage or clogging is found, replace the part with a new one.

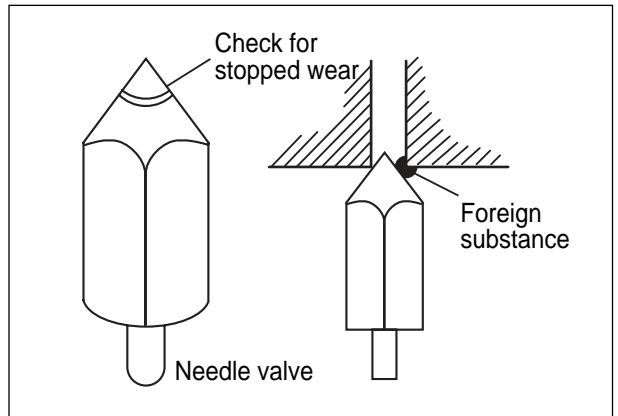

⊙ CLEANING

- Clean all jets by using compressed air.
- After cleaning, reassemble the carburetor with new seals and gaskets.

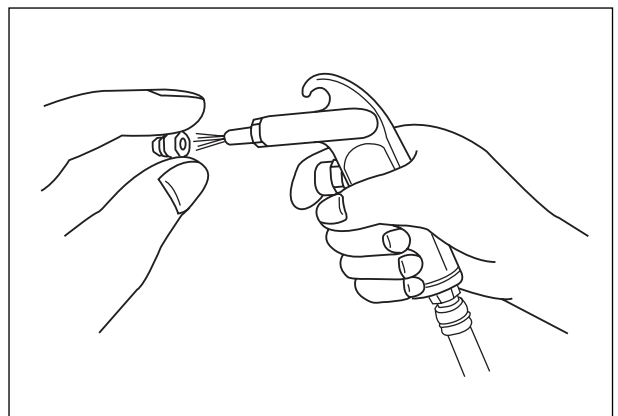

⊕ FLOAT HEIGHT ADJUSTMENT

To check the float height, turn the carburetor upside down. Measure the float height **A** while the float arm is just contacting the needle valve using vernier calipers.

Float height A	17mm (0.67 in)
------------------------------	----------------

 Vernier calipers : 09900-20101

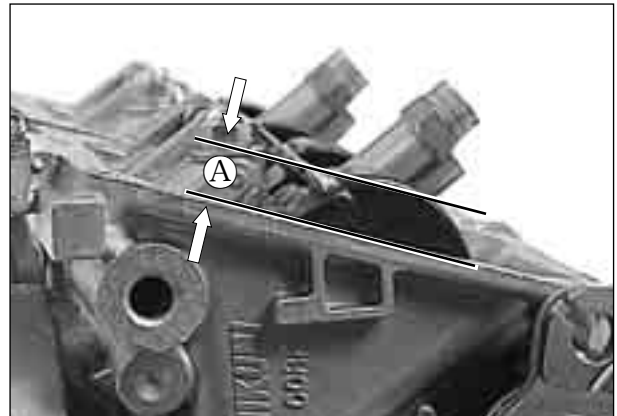

- Bend the float arm **①** as necessary to bring the height **A** to the specified level.
- After adjustment, check the float height and the fuel level again.

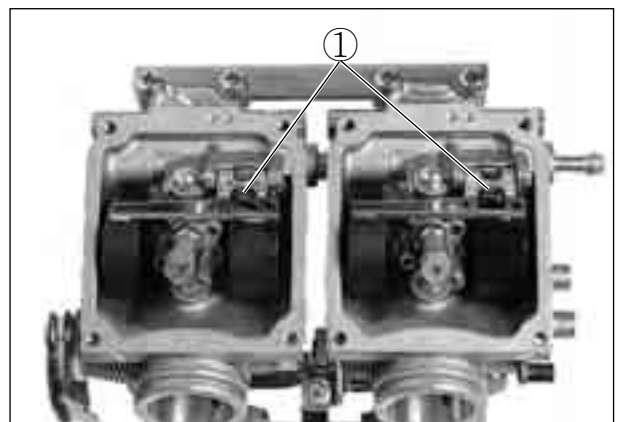

⊕ REASSEMBLY

Carburetor reassembly can be performed in the reverse order of disassembly. When reassembling, carefully observe the following instructions.

- After cleaning, reinstall the pilot screw to the original number of turn that is recorded during disassembly.

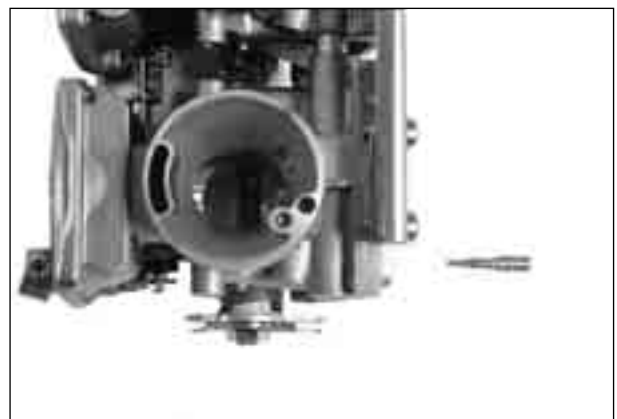

- Fit the seal rings securely to the float chamber and install the float chamber to the carburetor body.
- Install the eight screw **②**.

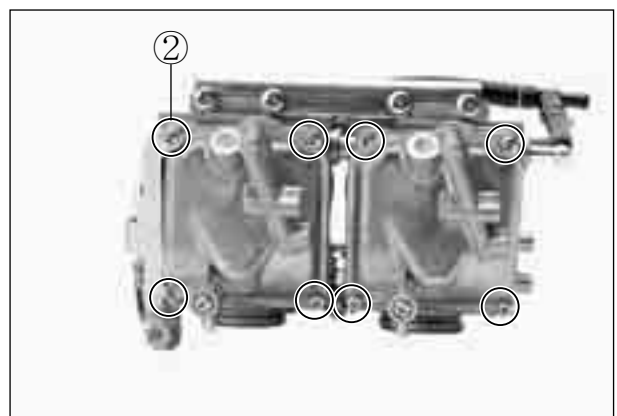

4-9 FUEL SYSTEM

- Install the jet needle with the pin ① on the spacer securely engaged with the hole ② on the piston valve.

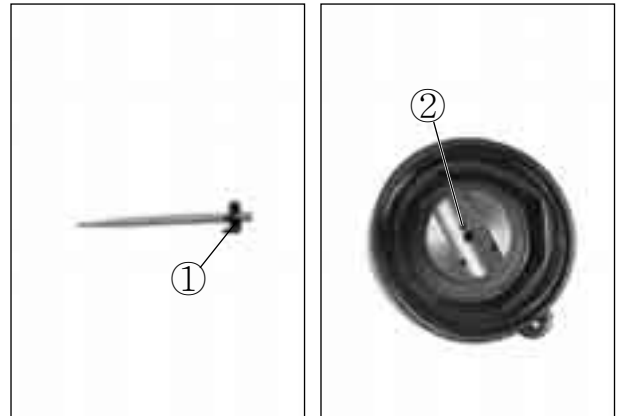

- Align the hole ③ of the diaphragm with passage way on the carburetor body.

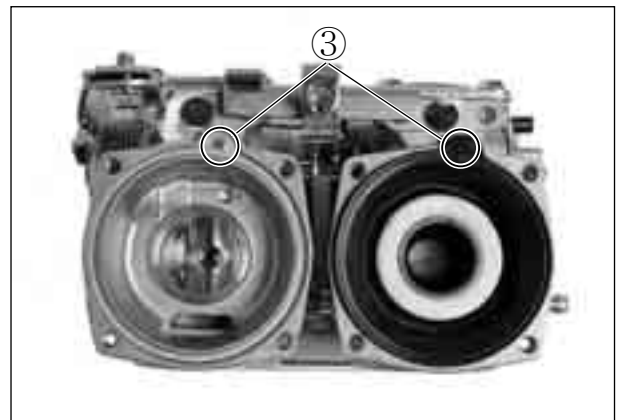

- Install the eight screw ④.



CAUTION

Never adjust “CO adjust screw” (A) of the carburetor. If adjust at discretion, have a bad influence upon output of the engine as the two carburetor is disharmonious.

- After the assembly and installation on the engine have been completed, perform the following adjustment.
Throttle cable adjustment. (Refer to page 2-7)
Idle speed adjustment. (Refer to page 2-7)

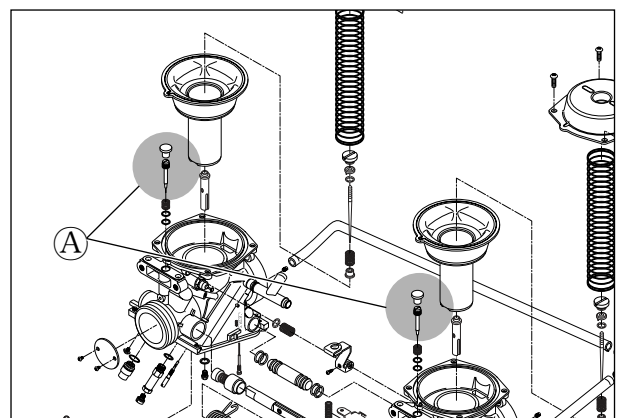

ELECTRICAL SYSTEM

CONTENTS

LOCATION OF ELECTRICAL COMPONENTS	5- 1
IGNITION SYSTEM	5- 3
CHARGING SYSTEM	5- 7
STARTER SYSTEM AND SIDE STAND IGNITION INTERLOCK SYSTEM	5- 11
SWITCHES	5- 15
LAMP	5- 16
BATTERY	5- 18
FUEL SYSTEM(『Comet-250』)	5- 21

LOCATION OF ELECTRICAL COMPONENTS

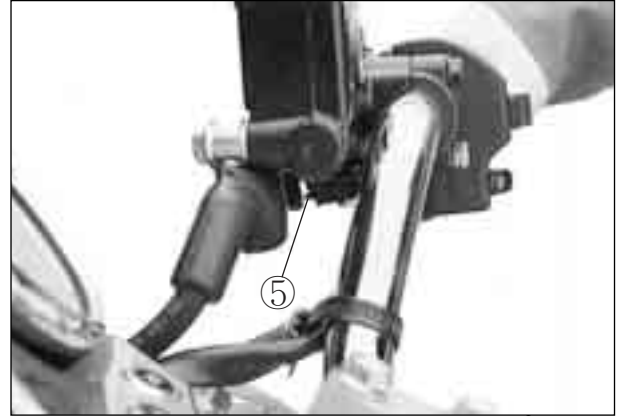
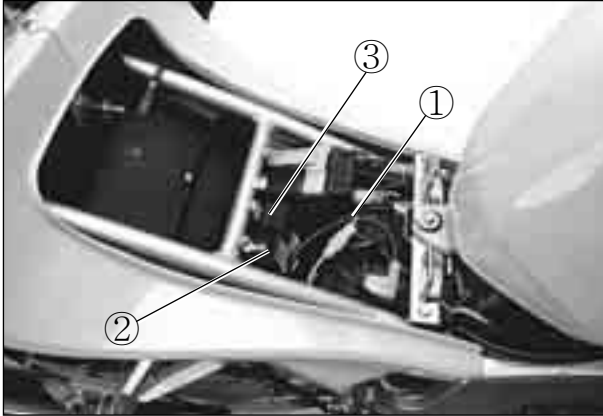

- ① Battery
- ② Turn signal relay
- ③ Head lamp relay
- ④ C.D.I Unit

- ⑤ Front brake lamp switch

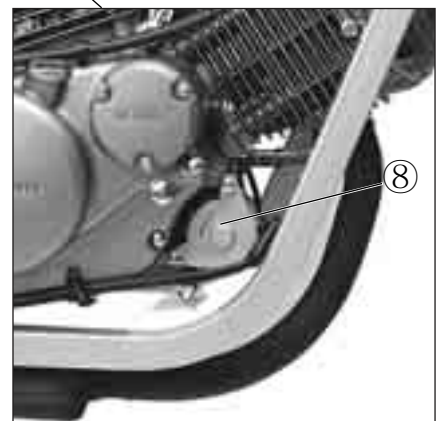
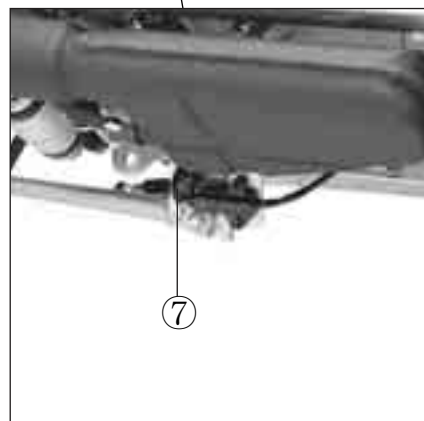
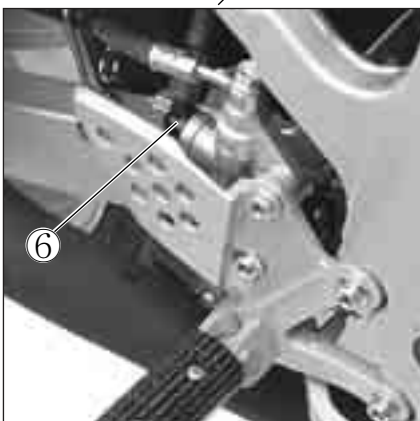
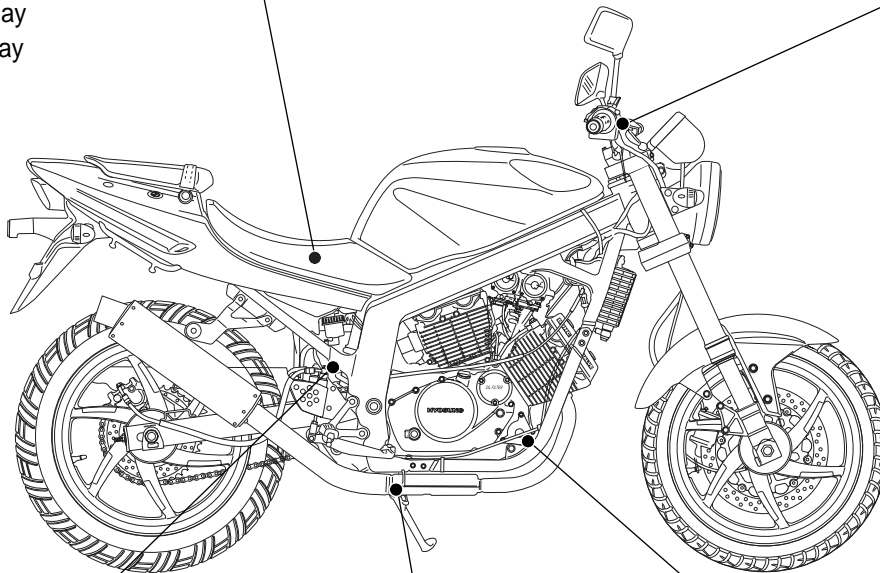

- ⑥ Rear brake lamp switch

- ⑦ Side stand switch

- ⑧ Starter motor

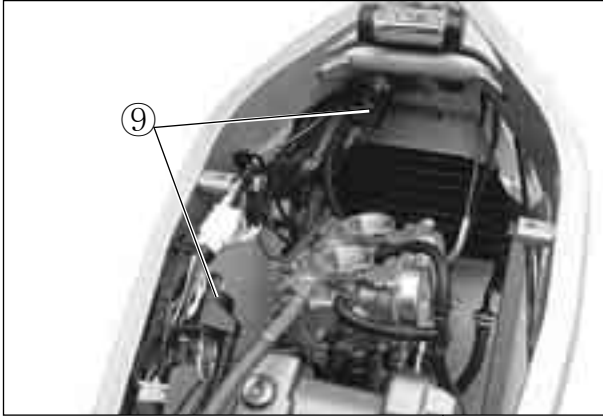

⑨ Ignition coil (NO.1 & NO.2)

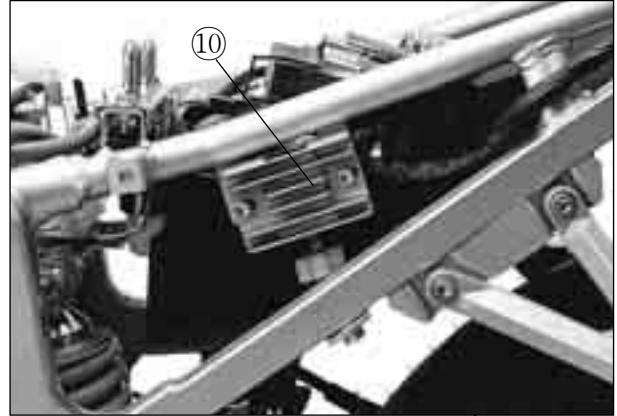

⑩ Regulator / Rectifier

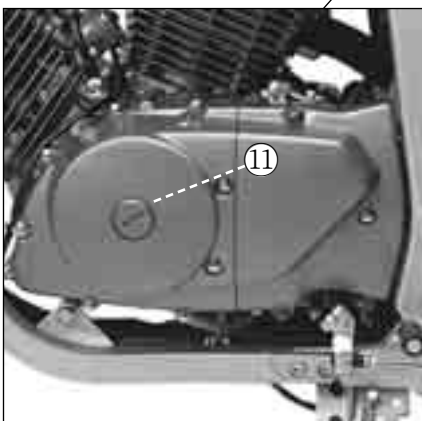
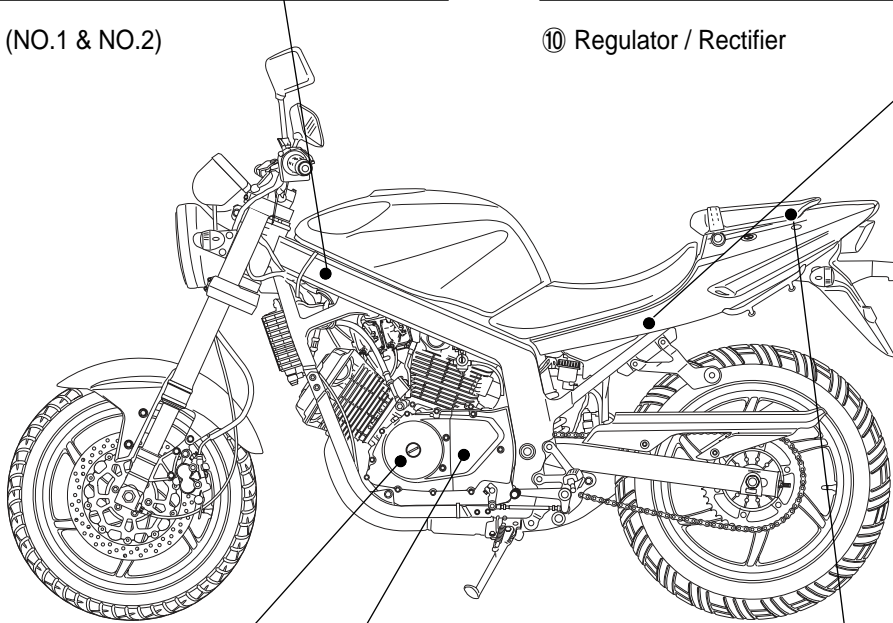

⑪ Magneto

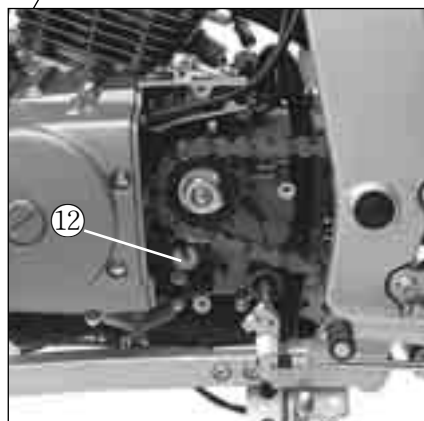

⑫ Gear position switch

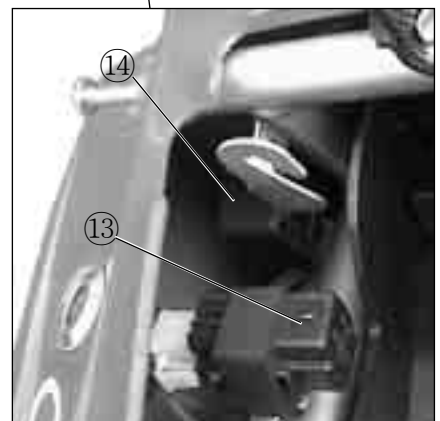

⑬ Fuse

⑭ Fuel pump relay (『Comst-250』)

IGNITION SYSTEM

『Comet 250』/『Comet 125』 is started as the battery discharged ignition system without a contact point. The battery ignition system is composed a rotor with five rotor tip, the D.C CDI, the ignition coil and battery. This system ignites after get signal from ignition timing of pick-up with the electric energy of this battery and occur the 1st electric current. Therefore, a high voltage current is induced in the secondary winding of the ignition coil and results in strong spark between spark plug gap.

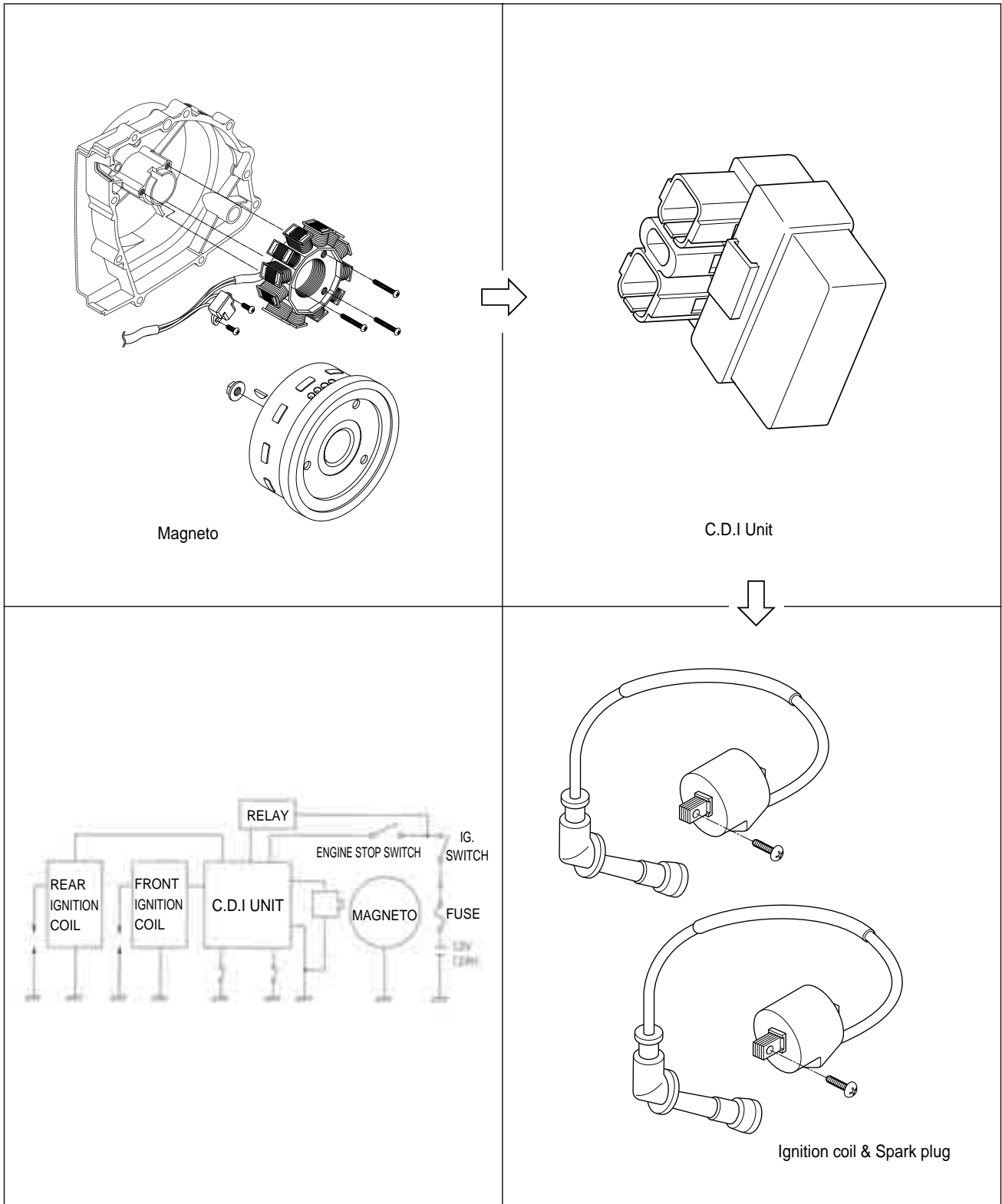

⊕ INSPECTION

■ MAGNETO

Using the pocket tester, measure the resistance between the lead wires in the following table.

Pick-up coil	G - L Approx 90~110 Ω
Charging coil	Y - Y Approx 0.6~0.9 Ω

 **TOOL** Pocket Tester : 09900-25002

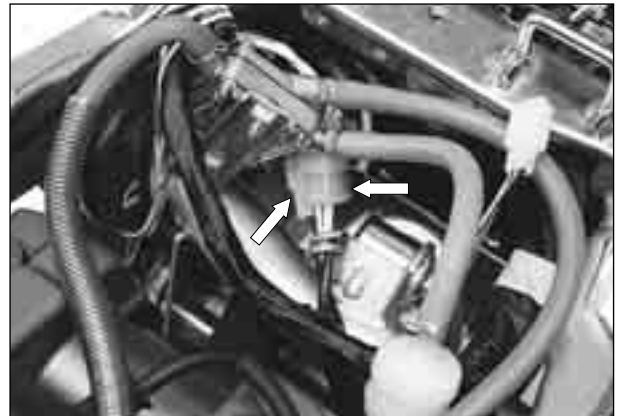

⚠ CAUTION

When mounting the stator on the magneto cover, apply a small quantity of **THREAD LOCK "1324"** to the threaded parts of screws.

 **1324** **THREAD LOCK "1324"**

WIRE COLOR

- L : Blue
- G : Green
- BY : Black with Yellow tracer
- OB : Orange with Black tracer
- Br : Brown
- BW : Black with White tracer
- WL : White with Blue tracer
- YG : Yellow with Green tracer



■ CDI UNIT

Using the pocket tester (R × 1kΩ range), measure the resistance between the terminal in the following table.

 **TOOL** Pocket Tester : 09900-25002



Unit : kΩ

	⊕ Probe of tester									
	1	2	3	4	5	6	7	8	9	10
⊖ Probe of tester	1	∞	∞	10-500	10-300	10-300	10-500	∞	10-300	10-500
	2	∞	∞	1-100	1-100	1-100	1-100	∞	1-100	1-100
	3	∞	∞	1-100	1-100	1-100	1-100	∞	1-100	1-100
	4	∞	∞	∞	∞	∞	∞	∞	∞	∞
	5	∞	∞	∞	10-500	∞	∞	∞	∞	10-500
	6	5-100	∞	∞	10-500	∞	∞	∞	∞	10-500
	7	5-100	∞	∞	∞	10-500	1-100	∞	10-500	∞
	8	5-100	∞	∞	10-300	∞	1-100	10-300	∞	10-300
	9	5-100	∞	∞	∞	∞	10-500	∞	∞	∞
	10	5-100	∞	∞	∞	10-500	1-100	∞	∞	10-500

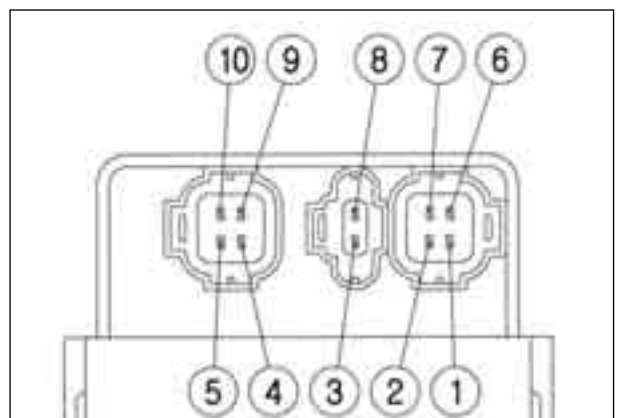

⚠ CAUTION

- ❖ Numerical value may differ a little according to the tester.
- ❖ Please remind that there may be a defect which can not be identified even though the measurement by using the tester indicates a low voltage.
- ❖ The range of measurement adjust a [x 1kΩ] unit.

■ IGNITION COIL

- Pull out the spark plug.
- Place it on the cylinder head after installing it at the plug cap to obtain ground.
- Push in the electric starter switch to rotate the starter motor, to have the test of sparking performance.
- If not emitted spark or the spark bring out the orange color, replace the ignition coil.

⚠ CAUTION

The ignition coil is marked the “F” for front, and the “R” for rear.
If otherwise, it may occur severe damage to the engine.

■ IGNITION COIL (Checking with Pocket Tester)

- A pocket tester or an ohm meter may be used, instead of the electro tester. In either case, the ignition coil is to be checked for continuity in both primary and secondary windings. Exact ohmic readings are not necessary, but, if the windings are in sound condition, their continuity will be noted with approximate ohmic values.

Ignition coil resistance

Primary	0.19~0.24Ω	Tester knob indication × 1Ω range
Secondary	5.4~6.6 kΩ	Tester knob indication × 1kΩ range
Check to attached plug cap		

 **Pocket tester : 09900-25002**

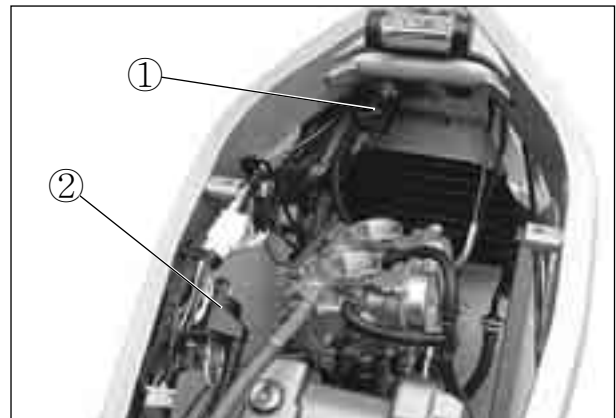

① Front cylinder ignition coil ② Rear cylinder ignition coil

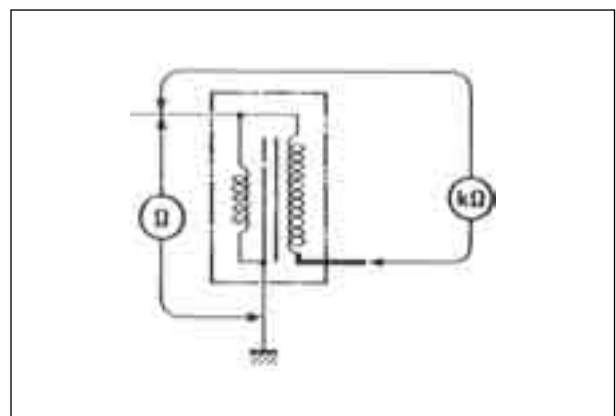
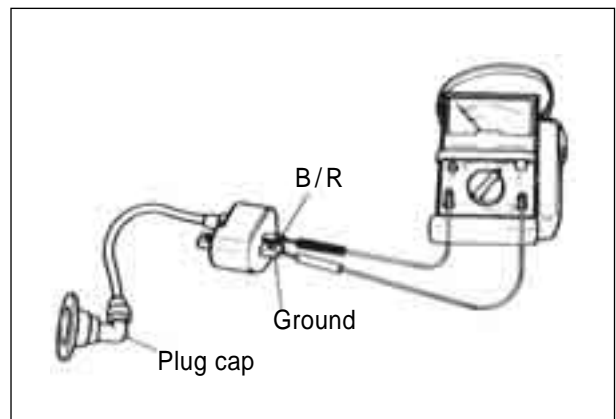
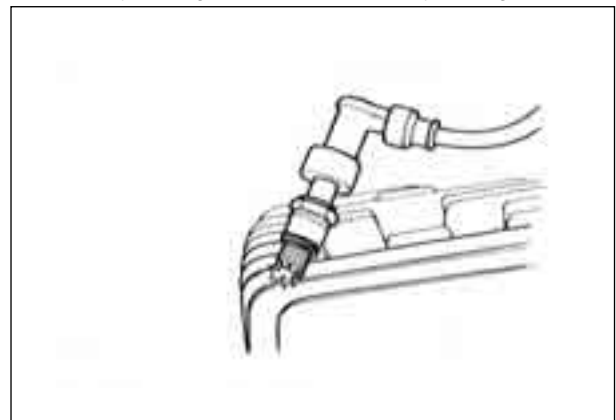

■ SPARK PLUG

Clean the plug with a wire brush and pin. Use the pin to remove carbon, taking care not to damage the porcelain.

- Check the gap with a thickness gauge.

 Thickness gauge : 09900-20806

Spark plug gap

0.7 ~ 0.8 mm
(0.028 ~ 0.032 in)

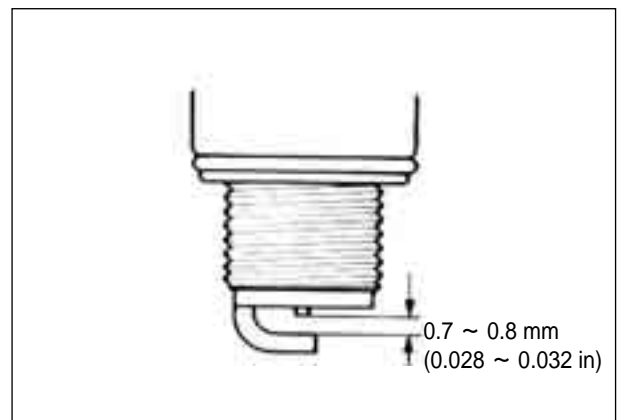
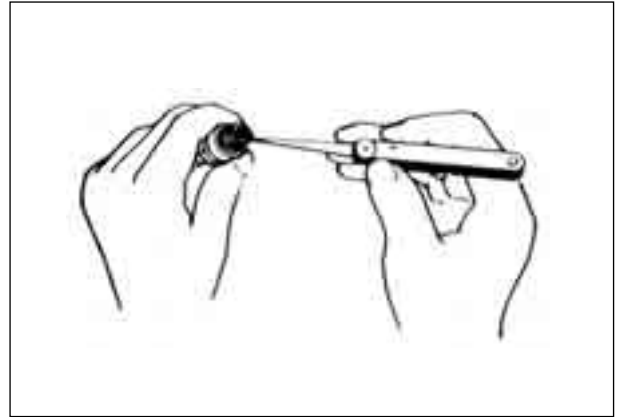

CHARGING SYSTEM

The circuit of the charging system is indicated in figure, which is composed of the AC generator, regulator / rectifier unit and battery. The AC current generated from the AC generator is converted by the rectifier and is turned into the DC current, then it charges the battery.

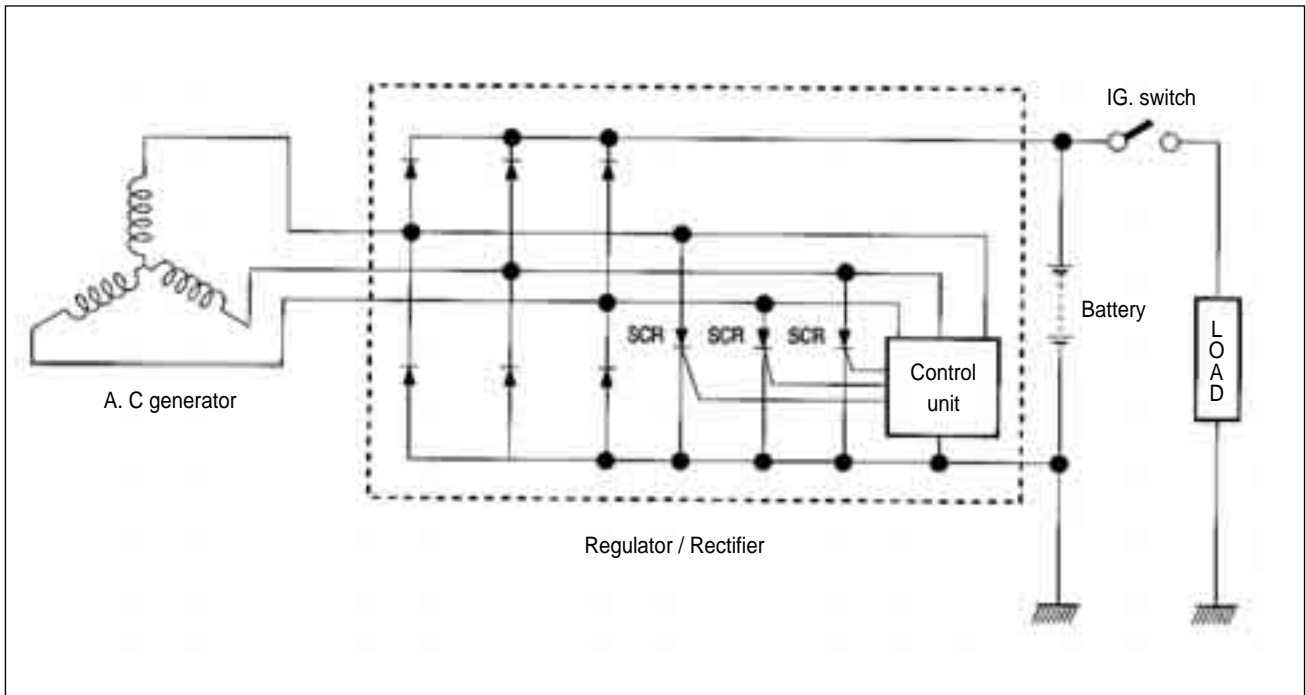

⊙ FUNCTION OF REGULATOR

While the engine rpm is low and the generated current of the AC generator is lower than the adjusted voltage of the regulator, the regulator does not function, incidentally the generated current charges the battery directly.

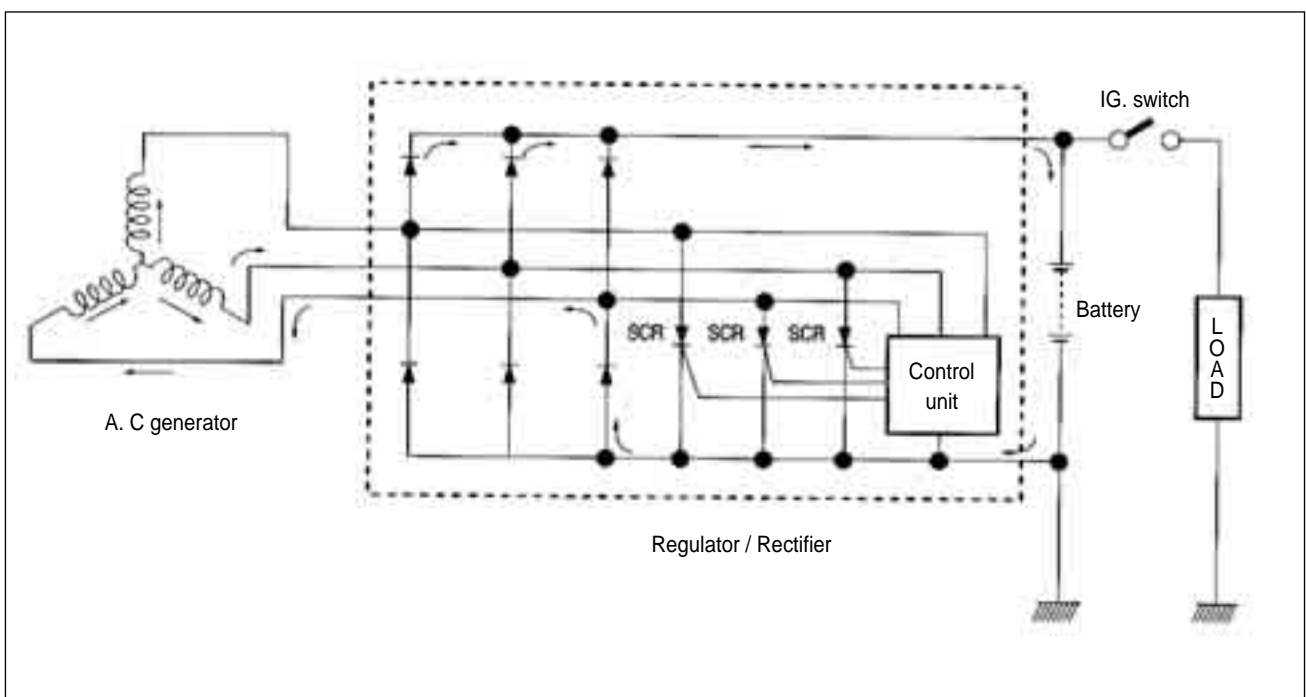

When the engine rpm become higher, the generated voltage of the AC generator also becomes higher and the voltage between points **A** and **B** of the regulator according becomes high, and when it reaches the adjusted voltage of the control unit, consequently the control unit becomes "ON" condition. On the "ON" condition of the control unit, signal will be sent to the SCR (Thyristor) gate probe and SCR will become "ON" condition. Then the SCR becomes conductive to the direction from point **A** to point **B**. Namely at the state of this, the current generated from the AC generator gets through SCR without charging the battery and returns to the AC generator again. At the end of this state, since the AC current generated from the AC generator flows into the point **B**, reverse current tends to flow to SCR, then the circuit of SCR turns to "OFF" mode and begins to charge the battery again. Thus these repetitions maintain charging constant voltage to the battery and protect it from overcharging.

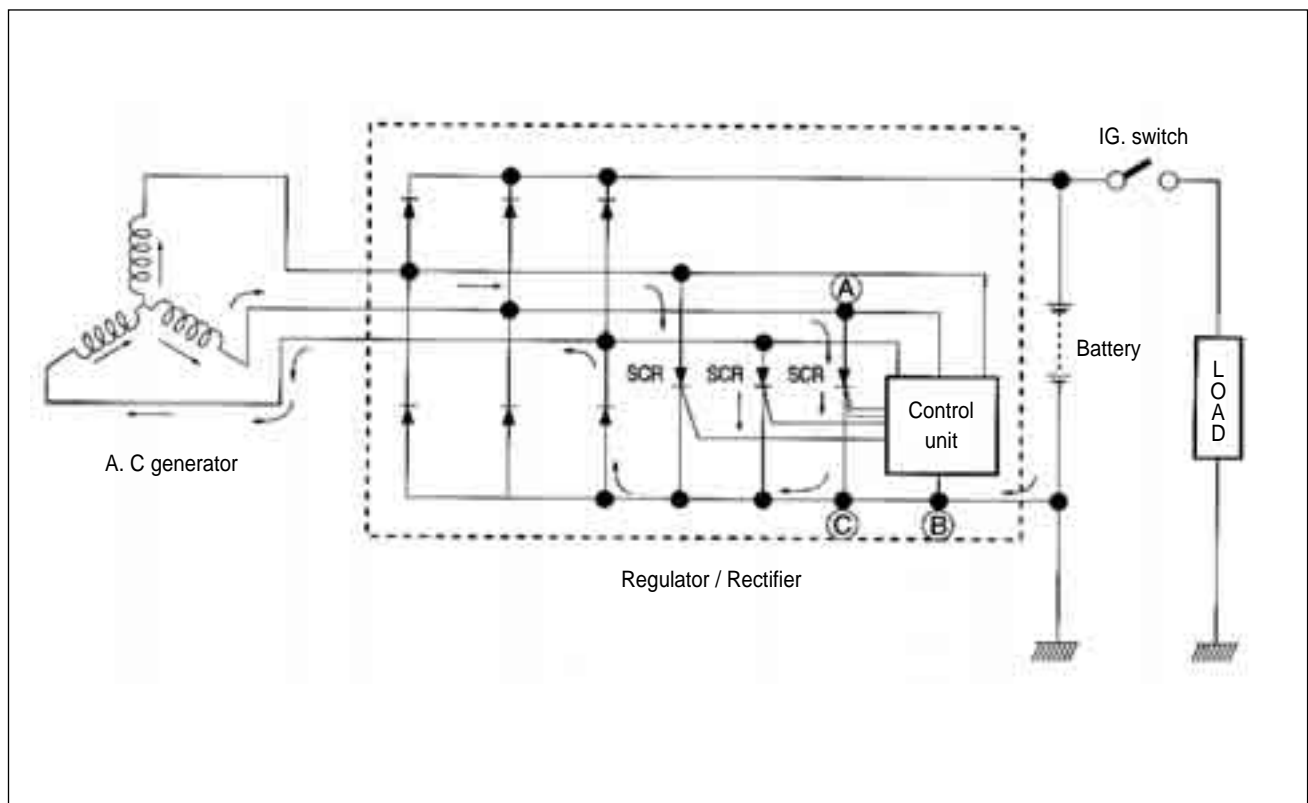

5-9 ELECTRICAL SYSTEM

⦿ INSPECTION

■ CHARGING OUTPUT CHECK

Start the engine and keep it running at 5,000 rpm.
Using the pocket tester, measure the DC voltage between the battery terminal ⊕ and ⊖.
If the tester reads under 14.0 V or over 15.0 V, check the magneto no-load performance and regulator / rectifier.

⚠ CAUTION

When making this test, be sure that the battery is full-charged condition.

 Pocket tester : 09900-25002

Standard charge	14.0 ~ 15.0 V (at 5,000 rpm)
------------------------	------------------------------

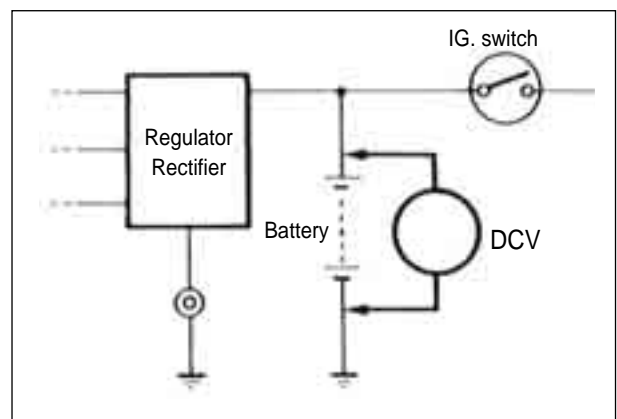

■ MAGNETO NO-LOAD PERFORMANCE

Disconnect the three lead wires from the magneto terminal.
Start the engine and keep it running at 5,000 rpm.
Using the pocket tester, measure the AC voltage between the three lead wires.
If the tester reads under 67 V or over 99 V the magneto is faulty.

Standard NO-load performance of magneto	67 ~ 99 V (at 5,000 rpm)
--	--------------------------

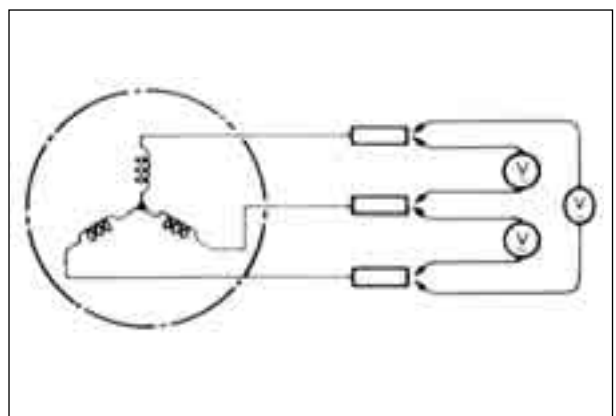

■ REGULATOR / RECTIFIER

- Disconnect the coupler.
- Using the multi-tester ($\times 1 \text{ k}\Omega$ range), measure the resistance between the terminals in the following table.

If the resistance checked is incorrect, replace the regulator / rectifier.

Unit : $\text{k}\Omega$

		⊕ Probe of tester				
⓪ Probe of tester		①	②	③	④	⑤
	①		0.8 ~ 2M Ω	0.8 ~ 2M Ω	0.8 ~ 2M Ω	30 ~ 55
	②	0.8 ~ 2M Ω		∞	∞	0.8 ~ 2M Ω
	③	0.8 ~ 2M Ω	∞		∞	0.8 ~ 2M Ω
	④	0.8 ~ 2M Ω	∞	∞		0.8 ~ 2M Ω
	⑤	30 ~ 55	0.8 ~ 2M Ω	0.8 ~ 2M Ω	0.8 ~ 2M Ω	

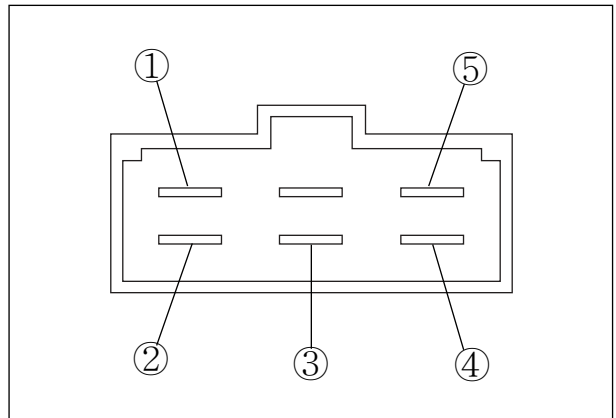
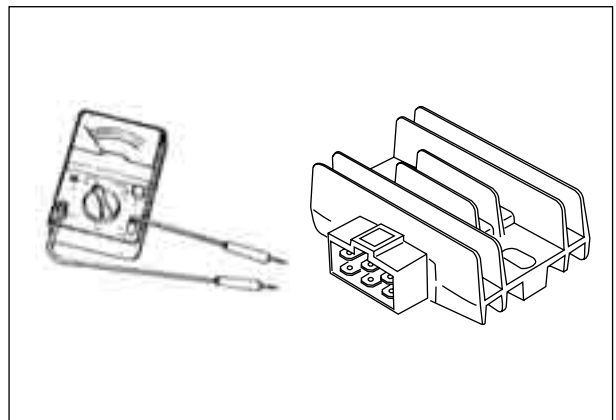
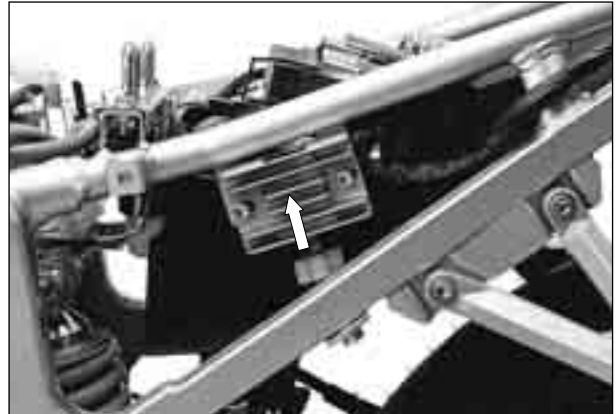

STARTER SYSTEM AND SIDE STAND IGNITION INTERLOCK SYSTEM

⦿ STARTER SYSTEM DESCRIPTION

The starter system consists of the following components : the starter motor, starter relay, clutch lever position switch, C.D.I unit, side stand switch, gear position switch, starter switch, engine stop switch, ignition switch and battery. Pressing the starter switch (on the right handlebar switch) energizes the starter relay, causing the contact points to close, thus completing the circuit from the starter motor to the battery.

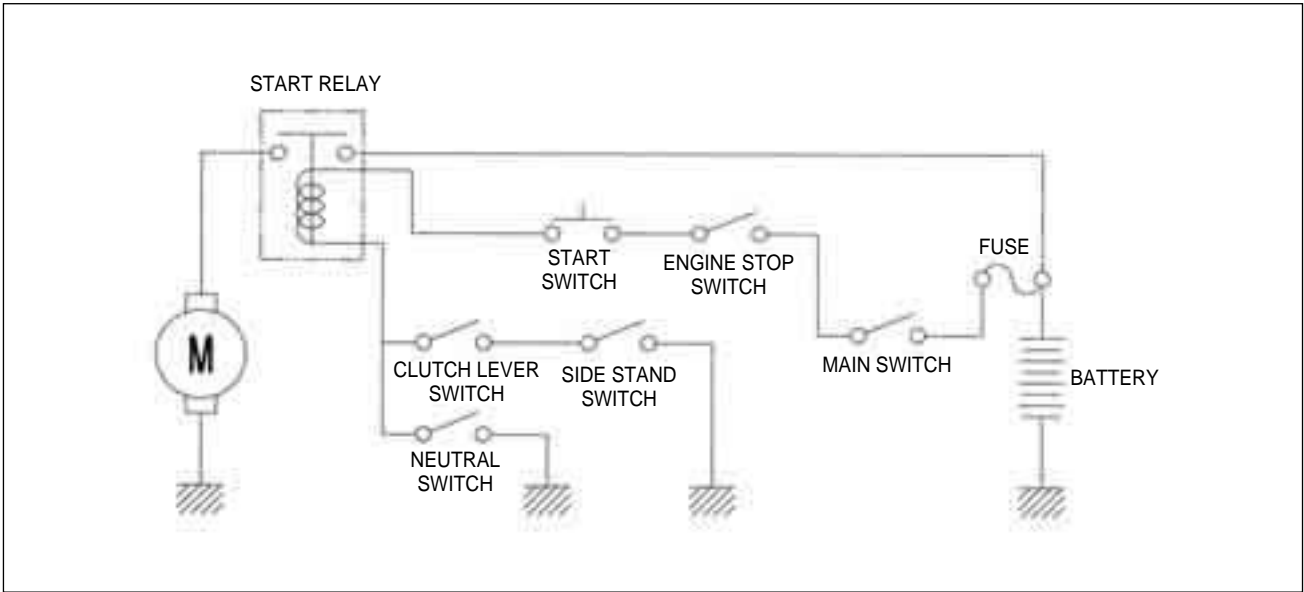

⦿ SIDE STAND / IGNITION INTERLOCK SYSTEM DESCRIPTION

This side stand / ignition interlock system prevents the motorcycle from being started with side stand down. The system is operated by an electric circuit provided between the battery and ignition coil. The circuit consists of the C.D.I unit, neutral indicator light and switches. The ignition coils will send voltage to the spark plugs dependant on what gear the transmission is in and whether the side stand is either up or down. The gear position and side stand switches work together in this system. The ignition coil work only in two situations as follows.

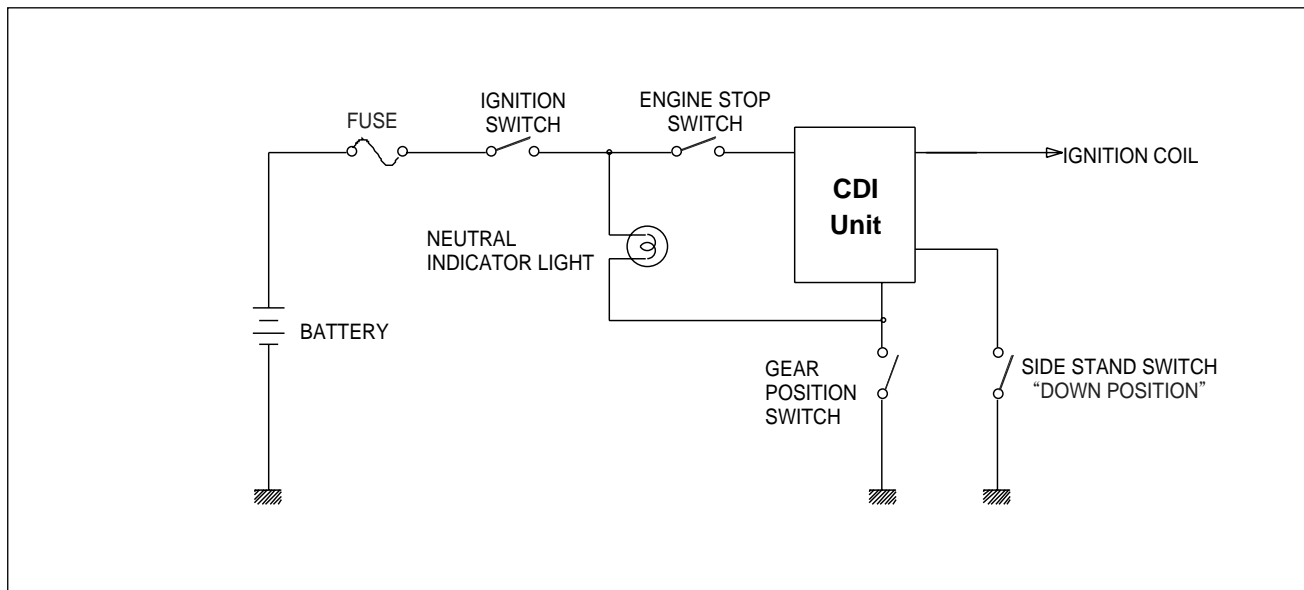

■ **TRANSMISSION : Neutral - "ON"**
 Side stand - Down ("OFF")

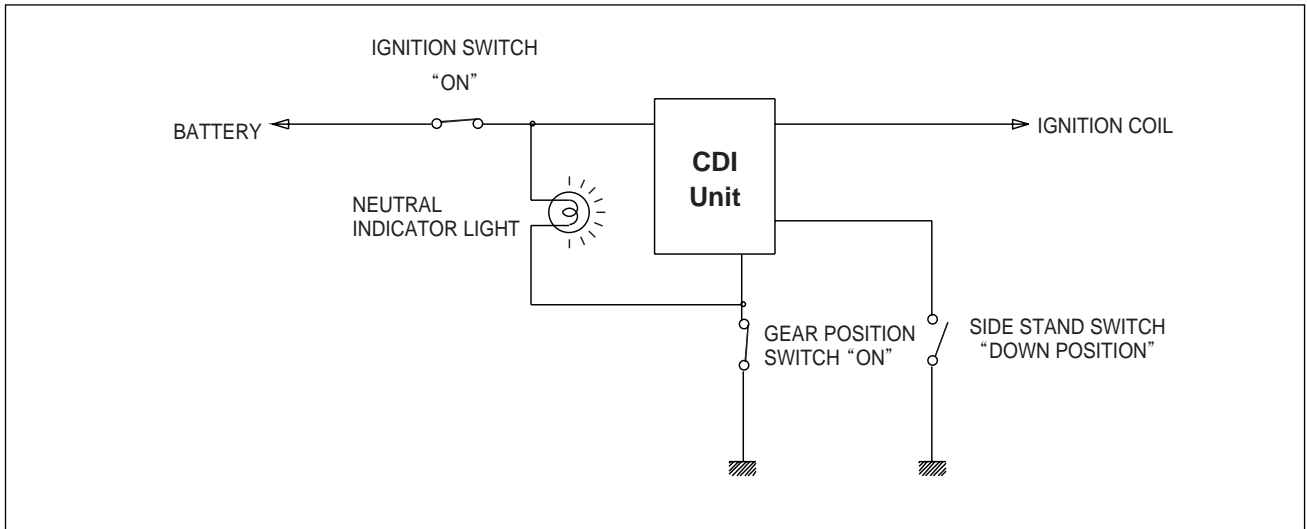

■ **TRANSMISSION : Neutral - "OFF"**
 Side stand - Up ("ON")

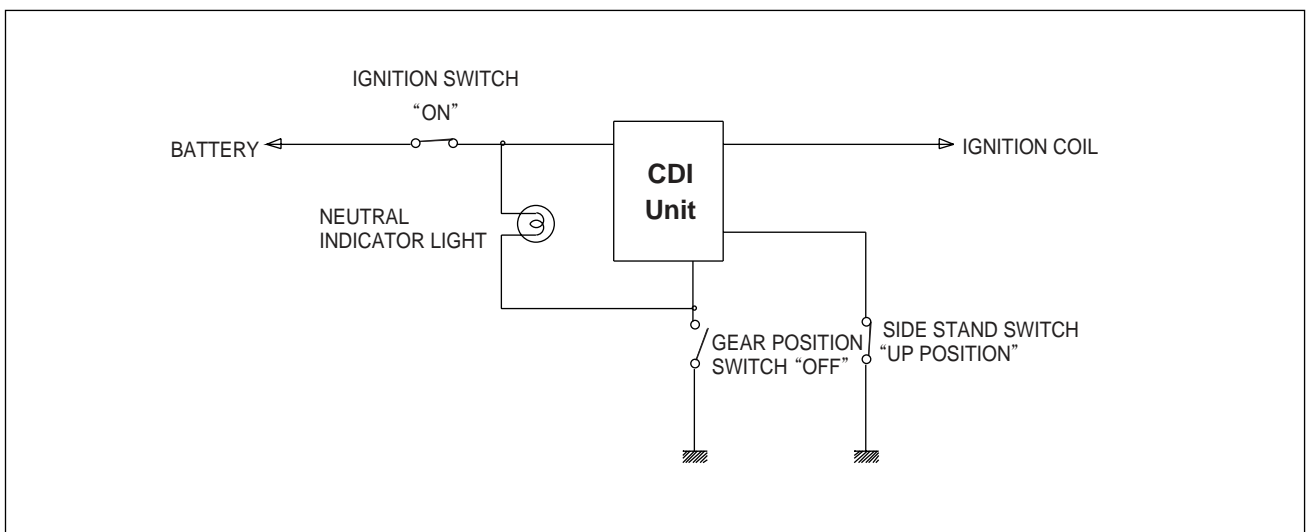

『Comet-250』 / 『Comet-125』 is equipped with the side stand ignition interlock system.

1. If the transmission is in neutral, you can start the engine regardless of clutch lever and side stand.
2. If the transmission is not in neutral, you can only start the engine with pulling in clutch lever and side stand up.

No	Neutral switch	Clutch lever	Side stand	Engine Start
1	●	△	△	Possible
2	△	●	●	Possible
3	△	●	△	Impossible
4	△	△	●	Impossible

NOTE	
●	On or Up.
△	Off or Down

⦿ **STARTER MOTOR REMOVAL AND DISASSEMBLY**

- Disconnect the starter motor lead wire ①.
- With loosen the bolt ②, remove the starter motor.
- Disassemble the starter motor.

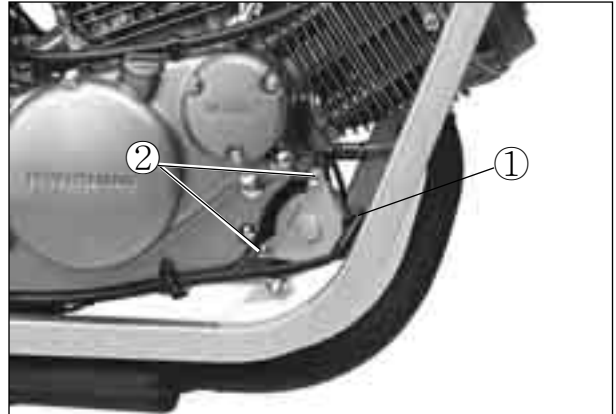

⦿ **STARTER MOTOR INSPECTION**

■ **CARBON BRUSH**

Inspect the brushes for abnormal wear, crack or smoothness in the brush holder.

If the brush has failed, replace the brush sub assy.

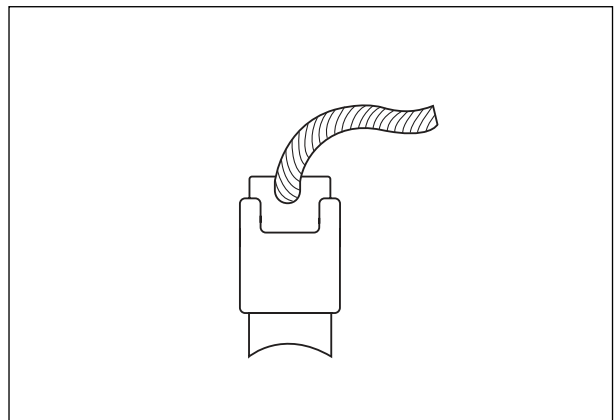

■ **COMMUTATOR**

Inspect the commutator for discoloration, abnormal wear or undercut (A).

If the commutator is abnormally worn, replace the armature.

When surface is discolored, polish it with #400 sand paper and clean it with dry cloth.

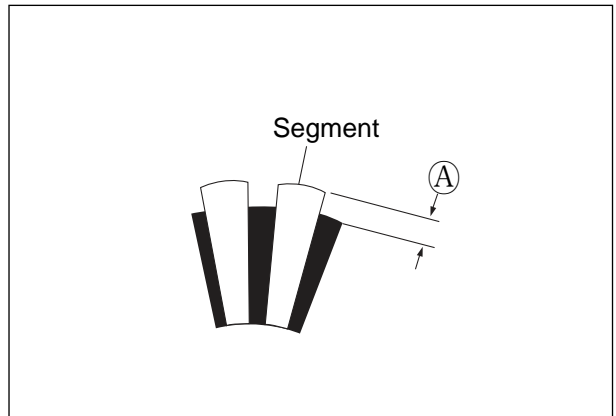

■ **ARMATURE COIL INSPECTION**

Check for continuity between each segment.

Check for continuity between each segment and the armature shaft.

If there is no continuity between the segments or there is continuity between the segment and shaft, replace the starter motor with a new one.

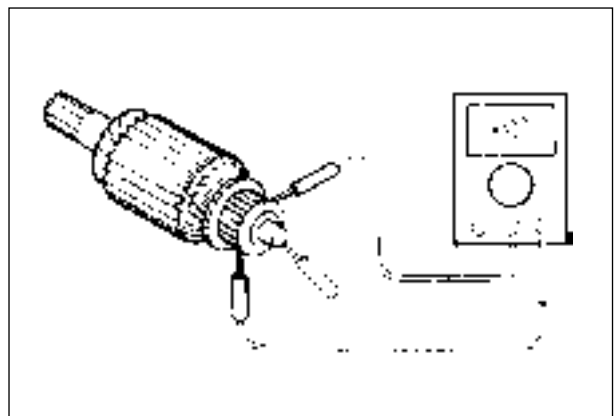

 **Pocket tester : 09900-25002**

STARTER MOTOR REASSEMBLY

Reassemble the starter motor. Pay attention to the following points :

- Reassembly the starter motor as shown in the illustration.

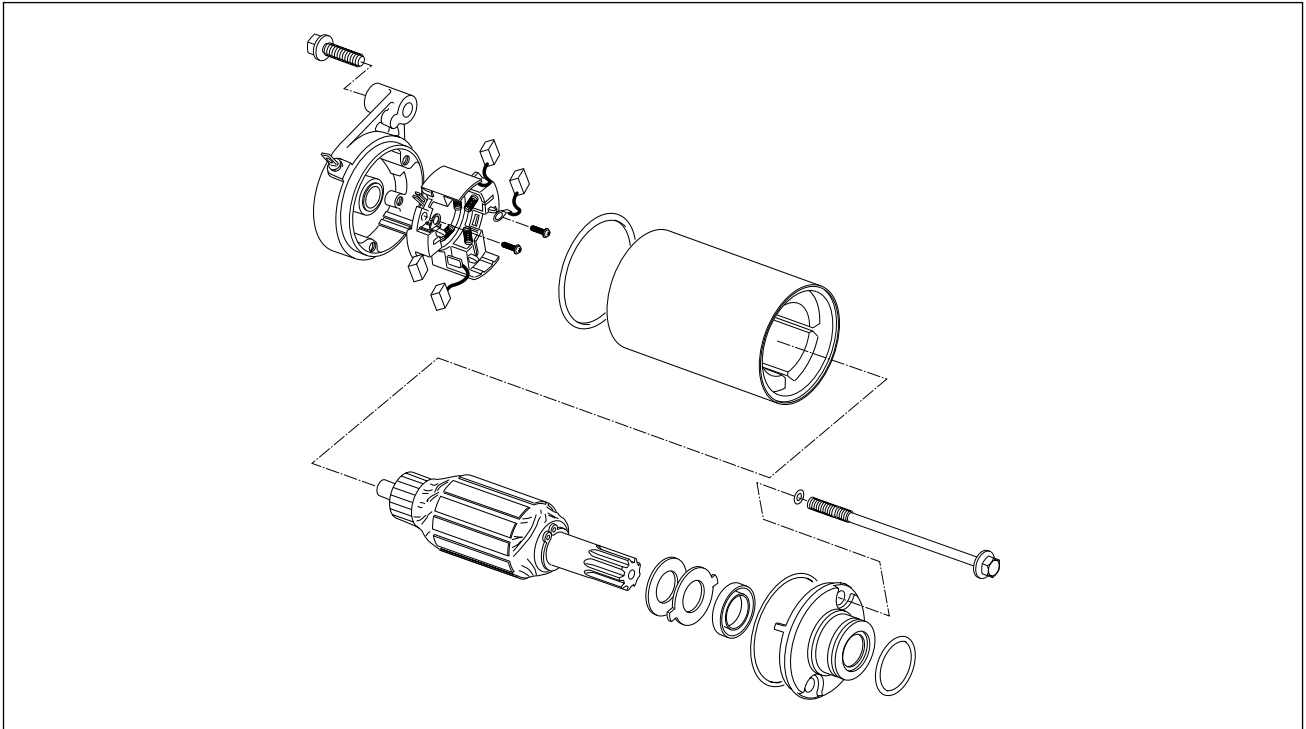

- Align the mark ① on the housing with the line ② on the housing end.

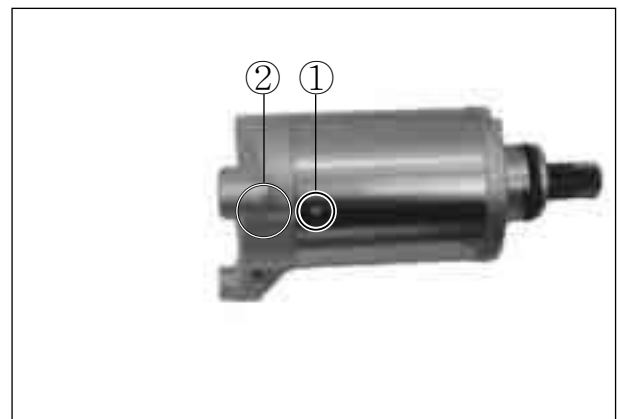

- Apply SUPER GREASE "A" to the O-ring ③ and remount the starter motor.

 SUPER GREASE "A"

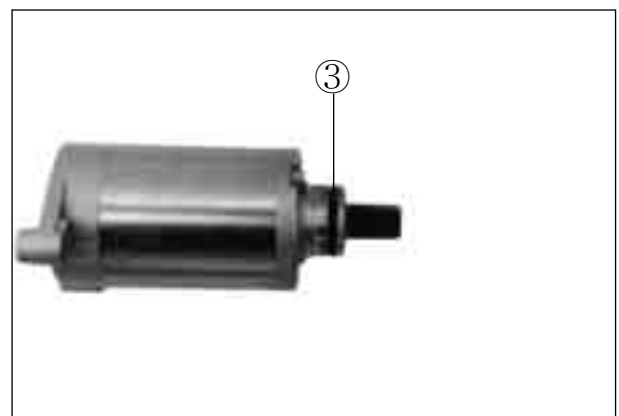

SWITCHES

Measure each switch for continuity using a tester. If any abnormality is found, replace the respective switch assemblies with new ones.

 **Pocket tester : 09900-25002**

IGNITION SWITCH				
	R	O	BW	BR
ON	○-----○			
OFF			○-----○	
LOCK			○-----○	

ENGINE STOP SWITCH		
	O	OB
	⊗	
	○-----○	

LIGHT SWITCH		
	O	Gr
	○-----○	
○		

STARTER SWITCH		
	OB	YG
ON	○-----○	
OFF		

DIMMER SWITCH			
	YW	Y	W
HI	○-----○		
LO	○-----○		

HORN SWITCH		
	G	BW
ON	○-----○	
OFF		

TURN SIGNAL SWITCH			
	Lg	Sb	B
L		○-----○	
PUSH			
R	○-----○		

FRONT/REAR BRAKE LAMP SWITCH		
	O	WB
ON	○-----○	
OFF		

LAMP

⦿ HEADLAMP

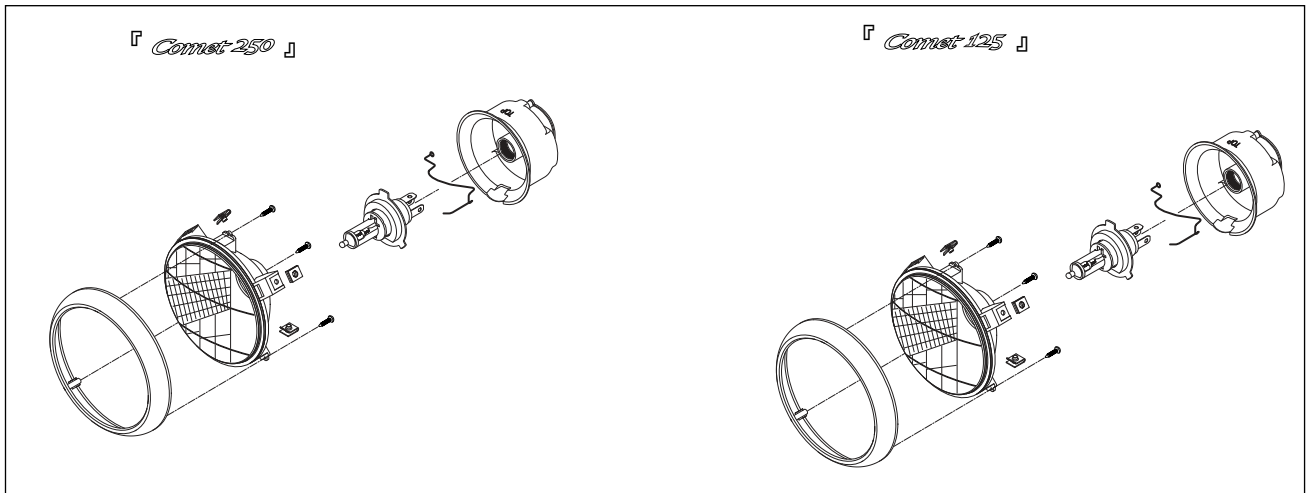

⦿ TURN SIGNAL LAMP

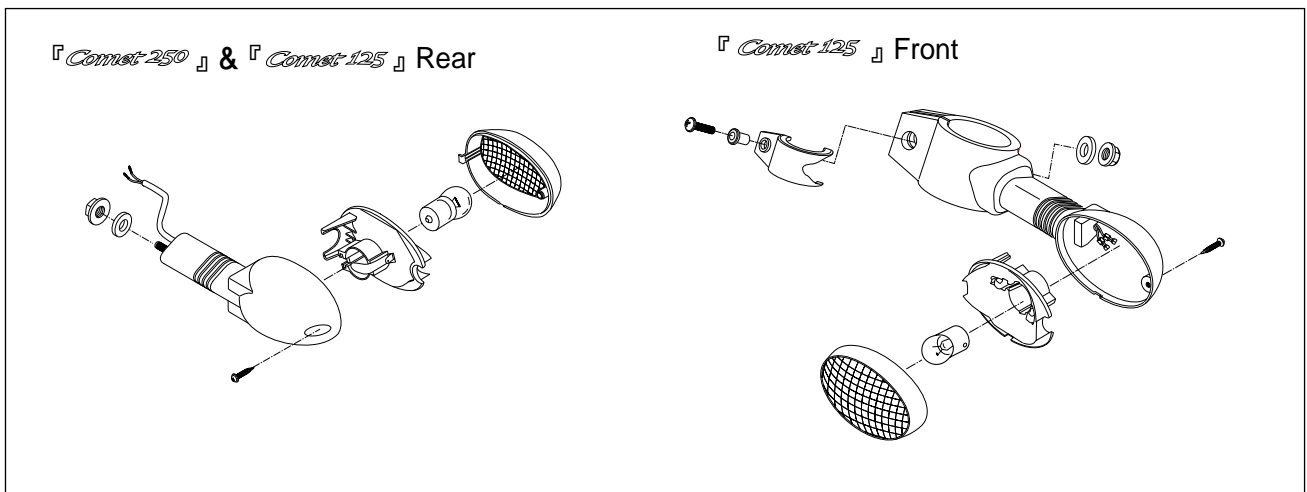

⦿ TAIL / BRAKE LAMP

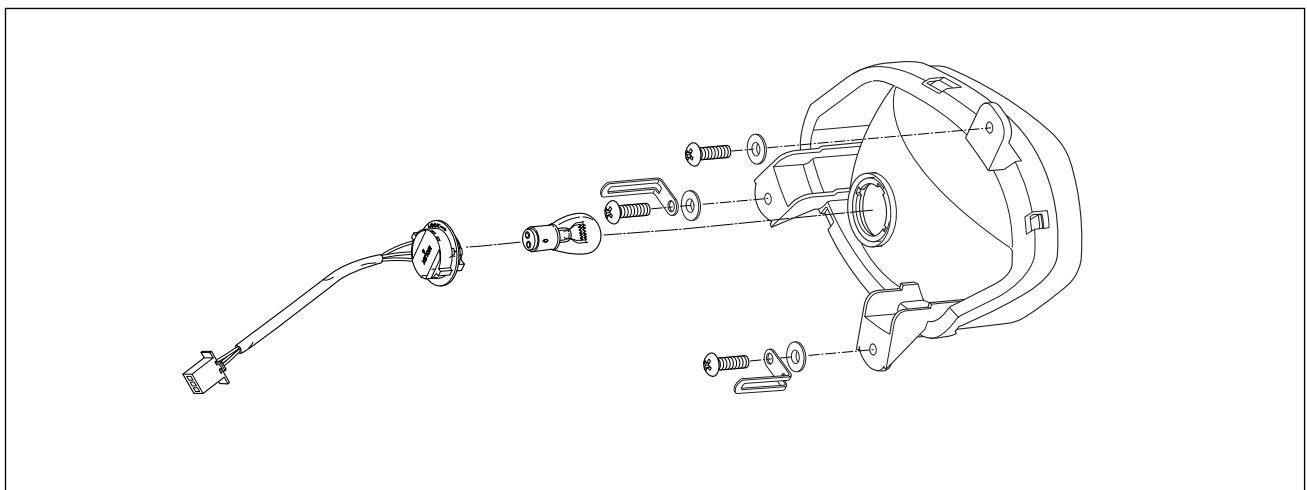

5-17 ELECTRICAL SYSTEM

⦿ COMBINATION METER

Remove the combination meter.

Disassemble the combination meter as shown in the illustration.

■ INSPECTION

Using the pocket tester, check the continuity between lead wires in the following illustration.

If the continuity measured incorrect, replace the respective part.



Pocket tester : 09900-25002



CAUTION

When making this test, it is not necessary to remove the combination meter.

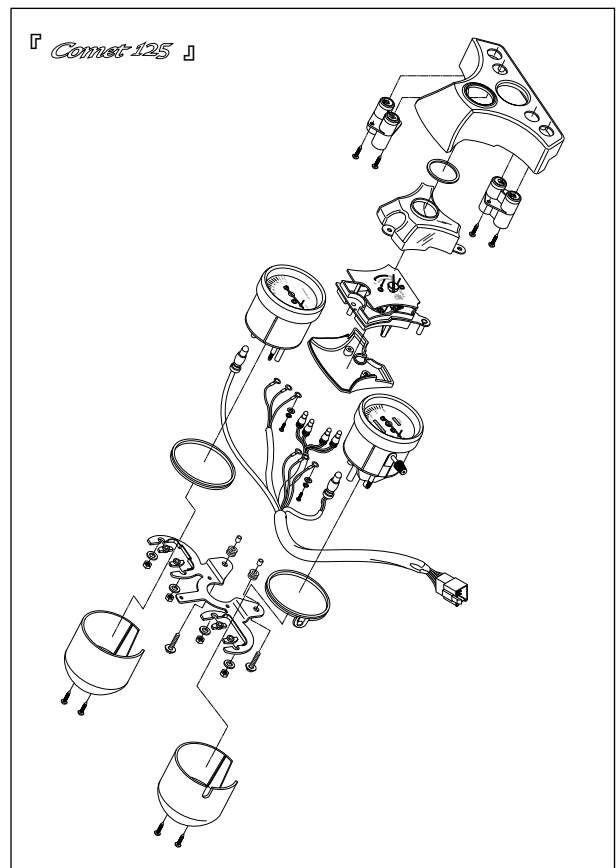
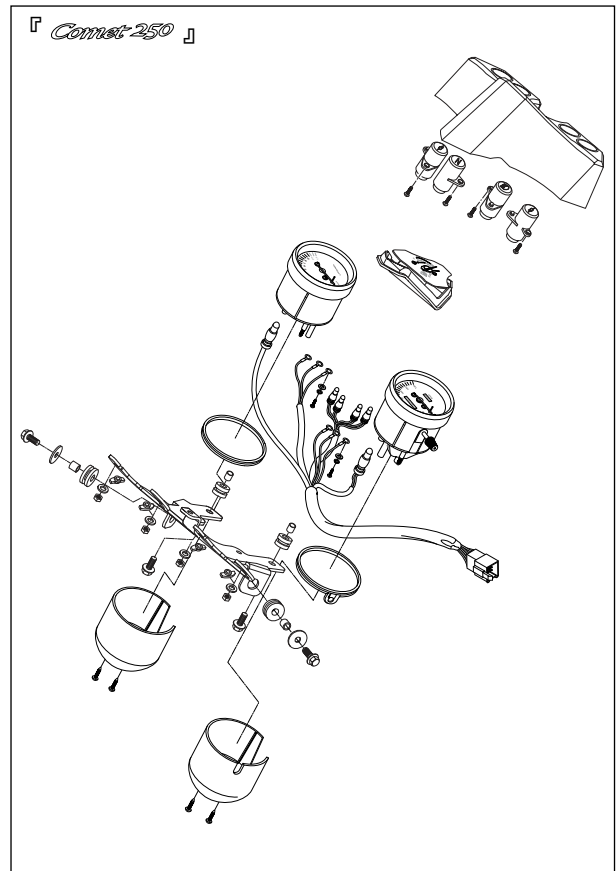
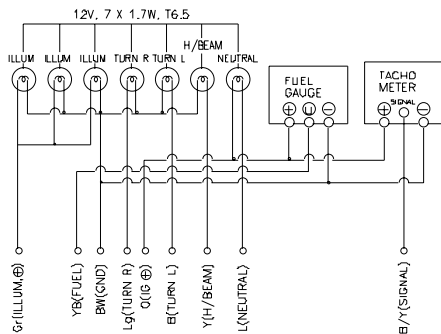

BATTERY

⊙ CAUTION OF BATTERY TREATMENT

The battery needs attention generally as it occur flammability gas.

If you don't follow the instruction in the below, there may be a explosion and severe accident.

Therefore, please pay attention to the following points.

- Prohibit positively battery from contacting to short, spark or firearms.
- The recharge of battery should be done in the wide place where the wind is well ventilated.
Please don't recharge it at the sight of wind-proof.

⊙ CAUTION OF BATTERY ELECTROLYTE TREATMENT

- Pay attention for the battery electrolyte not to stains the chassis or the humanbody.
- If stains the chassis or the humanbody, at once wash a vast quantity of water.
When it be stained, clothes should come into being a hole or painting should take off.
Be cured from a doctor.
- When the battery electrolyte was dropped to the surface of land, wash a vast quantity of water.
Neutralize by hydroxide, bicarbonate of soda and so on.

⊙ CAUTION OF MAINTENANCE FREE BATTERY TREATMENT

- Do not remove the aluminum tape to seal the battery electrolyte filler hole untill use as battery of completely seal type.
- Do not use it except the battery electrolyte.
- When pour into the battery electrolyte, necessarily use the electrolyte of the specified capacity.
- Do not open the sealing cap after recharge the battery eletrolyte.

- Filling electrolyte.

- ① Put the battery on even land and remove the aluminum tape sealing.
- ② Remove the cap at the electrolyte container.

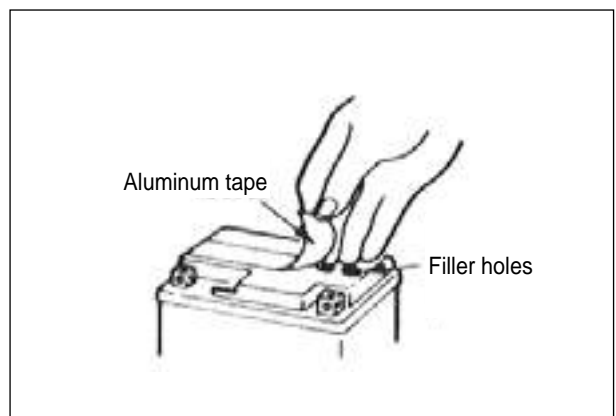
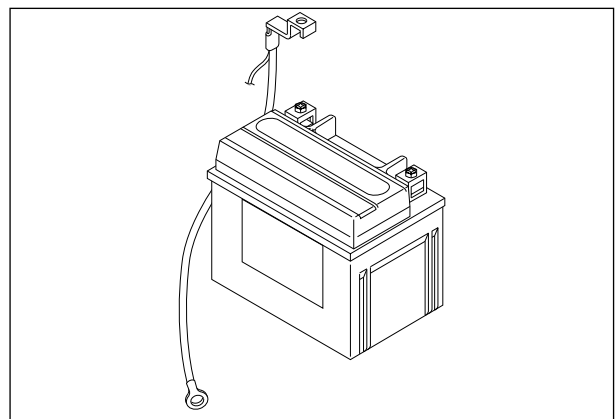

CAUTION

Do not remove the seal of the electrolyte container, not prick with sharp thing.

5-19 ELECTRICAL SYSTEM

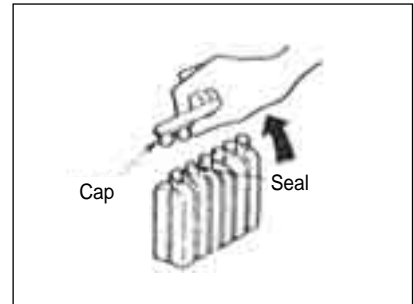
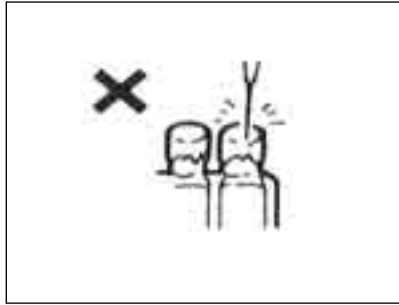
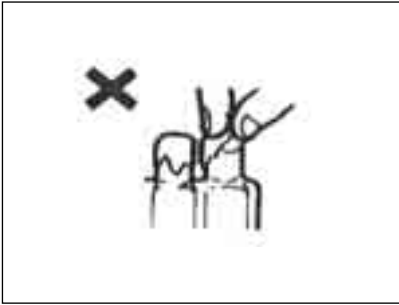

③ Pouring of battery electrolyte

When insert the nozzles of the electrolyte container into the battery's electrolyte filler holes, holding the container firmly so that it does not fall.

Take precaution not to allow any fluid to spill.

CAUTION

The pouring of electrolyte may not be done if the electrolyte container is pushed slopely.

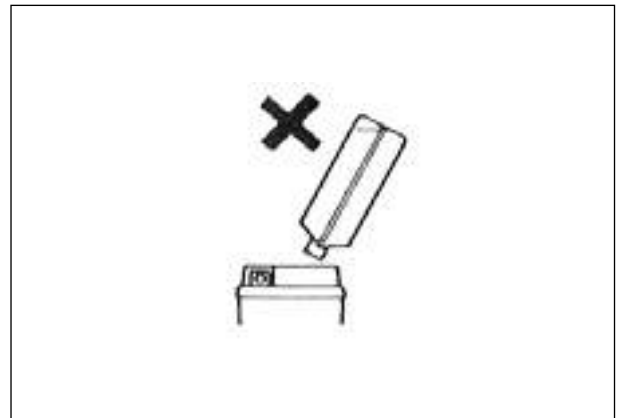
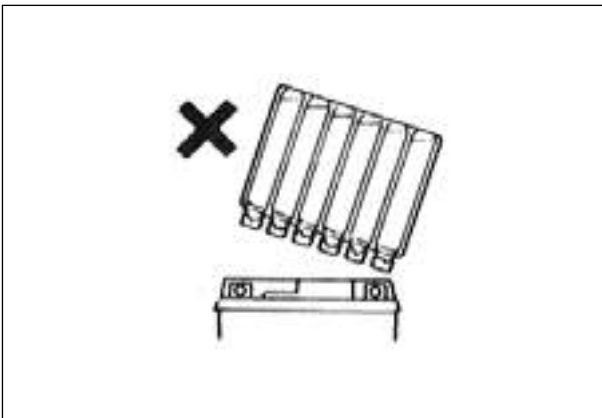
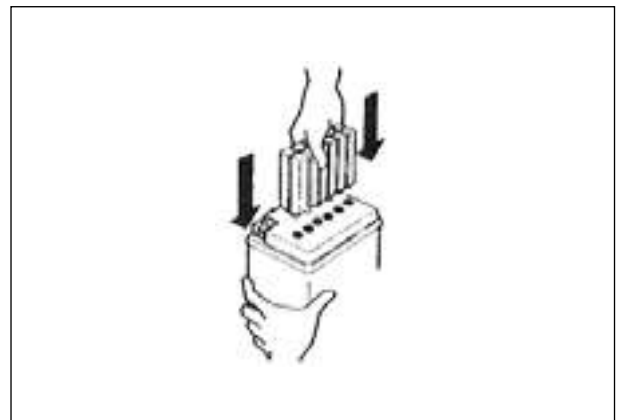

④ Confirmation of pour

Make sure that air bubbles are coming up each electrolyte container, and keep this position for more than about 20 minutes.

CAUTION

If no air bubbles are coming up from a filler port, tap the bottom of the two or three times.

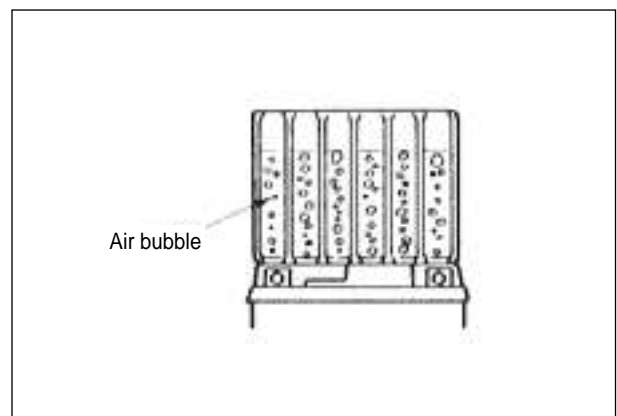

⑤ Separation of electrolyte container

After confirming that you entered the electrolyte into battery completely, remove the electrolyte containers from the battery.

**CAUTION**

Draw the empty receptacle out slowly because there may be a chance which remaining electrolyte vaporize.



⑥ Insert of the caps

Insert the cap into the filler holes, pressing it firmly so that the top of the caps do not protrude above the upper surface of the battery's stop cover.

⊙ **SERVICING**

Visually inspect the surface of the battery container. If any signs of cracking or electrolyte leakage from the sides of the battery have occurred, replace the battery with a new one. If the battery terminals are found to be coated with rust or an acidic white powdery substance, then this can be cleaned away with sandpaper.

⊙ **RECHARGING OPERATION**

● Using the pocket tester, check the battery voltage. If the voltage reading is less than the 12.0V (DC), recharge the battery with a battery charger.

**CAUTION**

When recharging the battery, remove the battery from the motorcycle.

NOTE

Do not remove the caps on the battery top while recharging.

**CAUTION**

Be careful not to permit the charging current to exceed 3A at any time.

- After recharging, wait for more than 30 minutes and check the battery voltage with a pocket tester.
- If the battery voltage is less than the 12.5V, recharge the battery again.
- If battery voltage is still less than 12.5V, after recharging, replace the battery with a new one.
- When the motorcycle is not used for a long period, check the battery every 1 month to prevent the battery discharge.

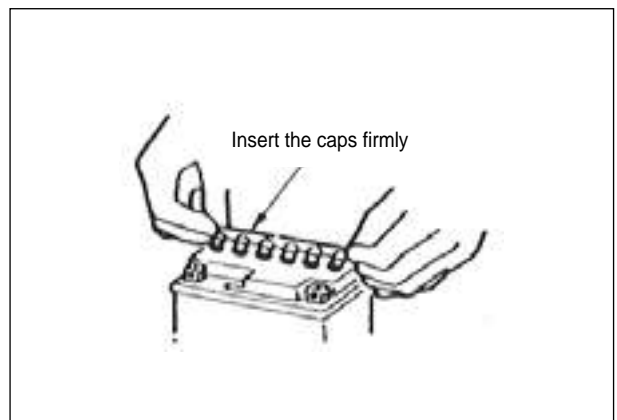
**How to charge**

Standard	1.4 A × 10 hours
Fast	6 A × 30 minutes

FUEL SYSTEM (『Comet 250』)

⊙ FUEL PUMP

- Remove the front seat and fuel tank.
- Remove the fuel pump lead wire coupler.

Using the pocket tester (X 1Ω range), measure the resistance between the terminals in the following table.

If the resistance checked is incorrect, replace the fuel pump.

Fuel pump resistance	4.5 ~ 10.0 Ω (BW-BL)
-----------------------------	-----------------------------

 **Pocket tester : 09900-25002**

⊙ FUEL PUMP RELAY

- Remove the fuel pump relay coupler.

Using the pocket tester (X 1Ω range), measure the resistance between the terminals in the following table.

If the resistance checked is incorrect, replace the fuel pump relay.

Unit : Ω

⊖ Probe of tester	⊕ Probe of tester			
	1	2	3	4
1	—	∞	∞	∞
2	∞	—	700-950	∞
3	∞	700-950	—	∞
4	∞	∞	∞	—

 **Pocket tester : 09900-25002**

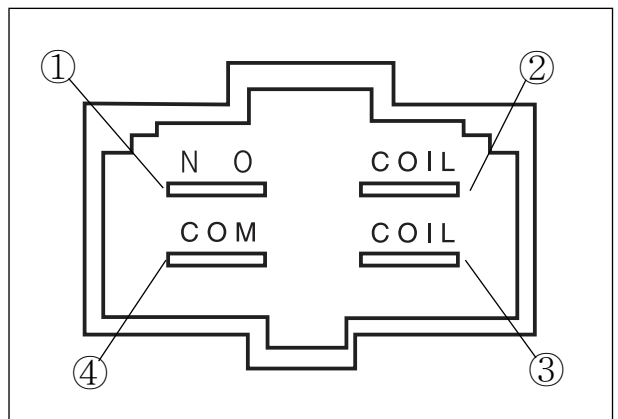

CHASSIS

CONTENTS

EXTERIOR PARTS	6- 1
FRONT WHEEL	6- 2
FRONT BRAKE	6- 6
HANDLEBARS	6- 12
FRONT FORK (『Comet 250』)	6- 14
FRONT FORK (『Comet 125』)	6- 20
STEERING	6- 27
REAR WHEEL	6- 30
REAR BRAKE	6- 34
REAR SHOCK ABSORBER	6- 36
SWING ARM	6- 37

EXTERIOR PARTS

⊙ FRONT FENDER

- With the bolts removed, remove the front fender.



⊙ REAR SEAT

- Remove the rear seat with the ignition key.

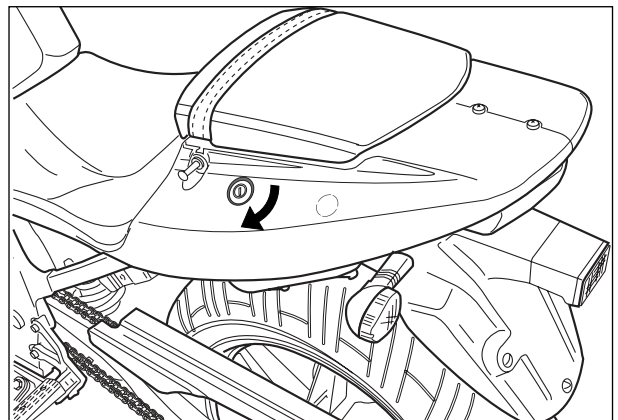

⊙ FRONT SEAT

- To remove the front seat, pull the knob located under the rear seat.

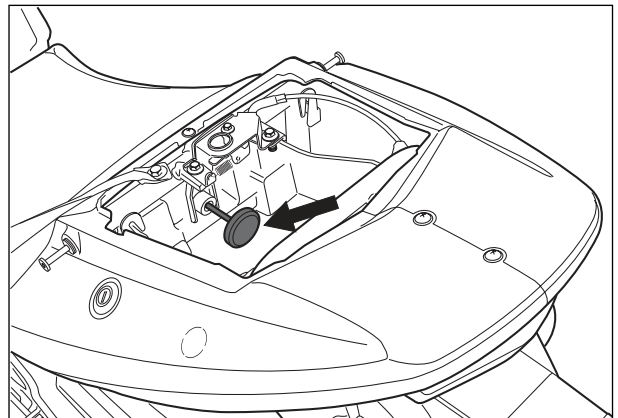

FRONT WHEEL

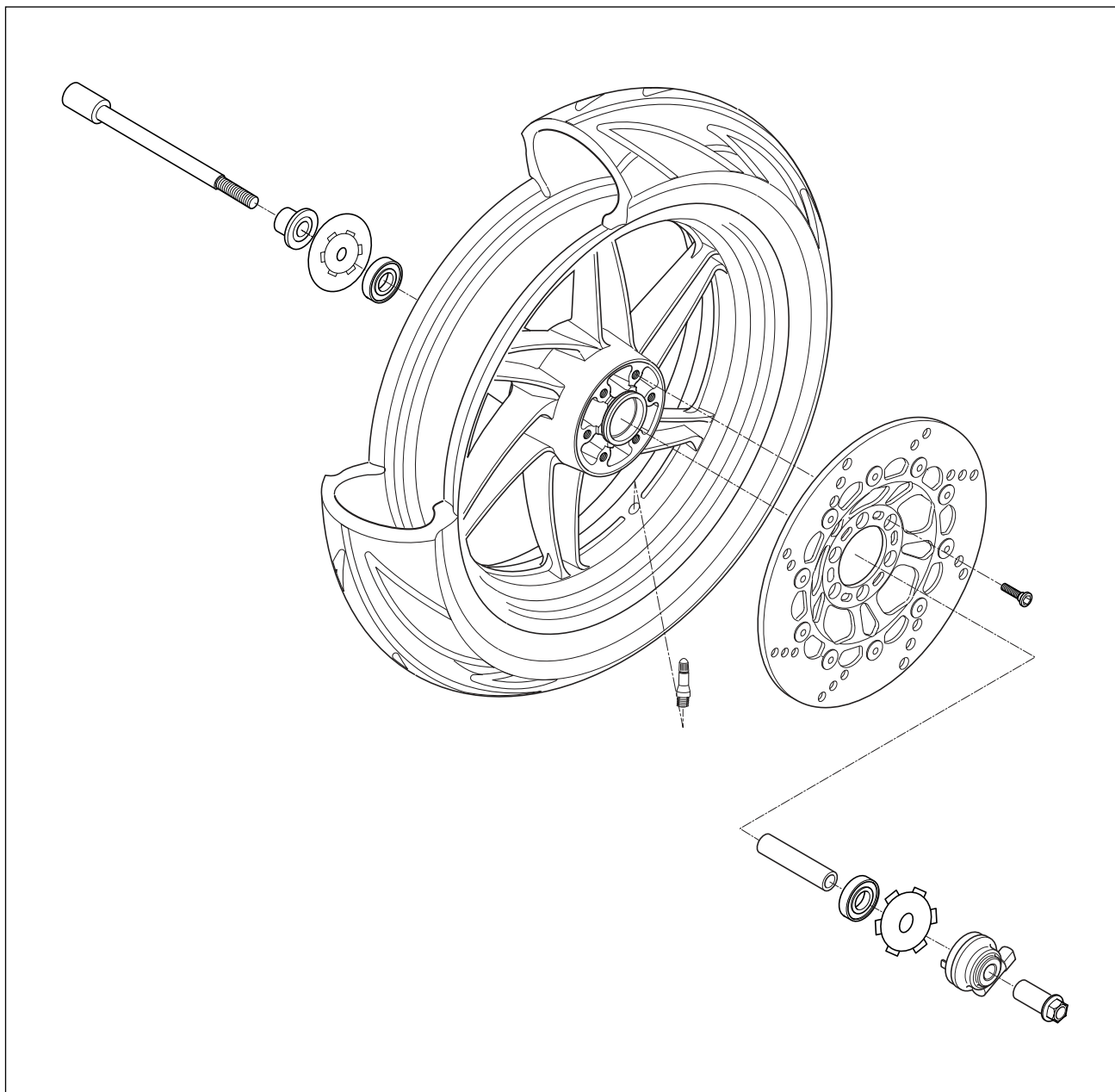

⊙ **REMOVAL**

- Loosen the axle pinch bolt ①, right and left.
- Loosen the front axle ②.
- Raise the front wheel off the ground with a block or jack.

⚠ **CAUTION**

When using a jack, take care not to cause scratches on the chassis.

- Remove the front wheel by removing the front axle ②.

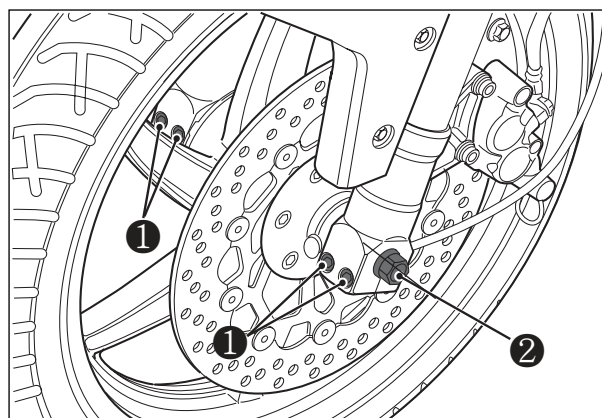

6-3 CHASSIS

- Remove the brake disc.

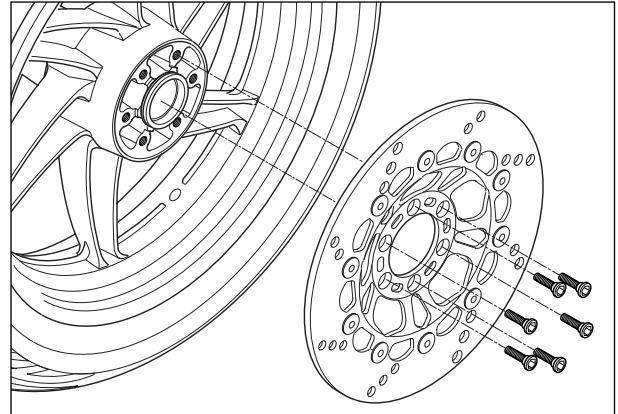

⊙ INSPECTION AND DISASSEMBLY

■ TIRE

For inspection of the tire : Refer to page 2-18.

■ FRONT AXLE

Measure the front axle runout using the dial gauge. If the runout exceeds the limit, replace the front axle.

Axle shaft runout	Service limit
	0.25 mm (0.01 in)

-  **Dial gauge : 09900-20606**
- Magnetic stand : 09900-20701**
- V-block : 09900-21304**

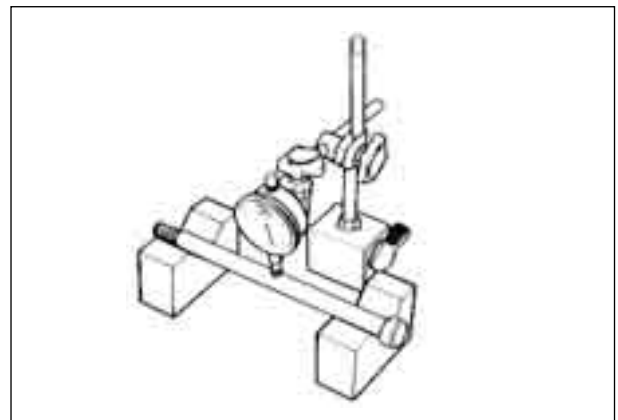

■ WHEEL

Make sure that the wheel runout (axial and radial) does not exceed the service limit when checked as shown. An excessive amount of runout is usually due to worn or loose wheel bearings and can be corrected by replacing the bearings. If bearing replacement fails to reduce the wheel.

Wheel runout (axial and radial)	Service limit
	2.0 mm (0.08 in)

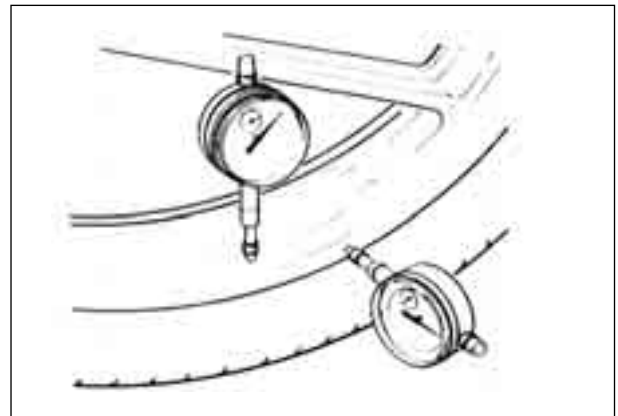

■ WHEEL BEARING

Inspect the play of the wheel bearings by finger while they are in the wheel. Rotate the inner race by finger to inspect for abnormal noise and smooth rotation. Replace the bearing in the following procedure if there is anything unusual.

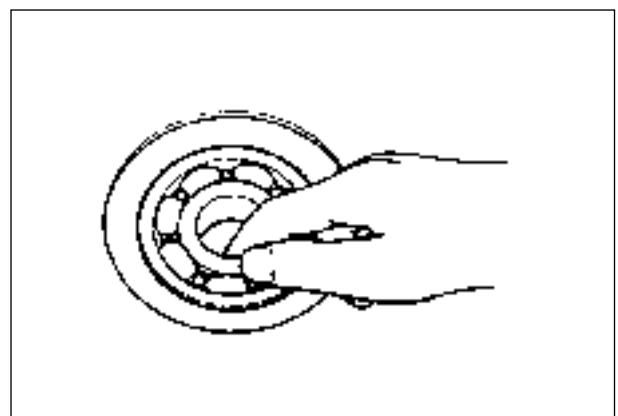

■ WHEEL BEARING REMOVAL

- Remove the wheel bearing by using the special tool.

 Wheel bearing remover : 09941-50111

CAUTION

The removed bearing should be replaced with new ones.

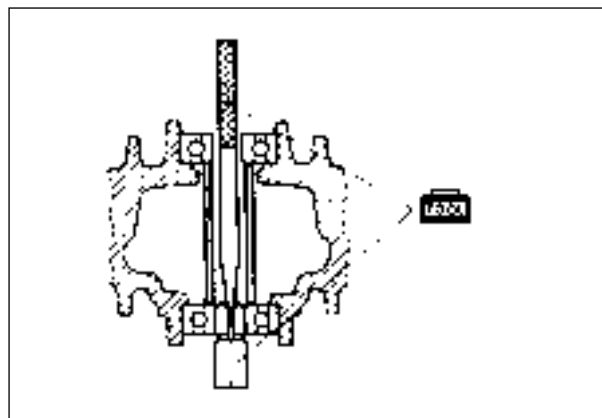

⊙ REASSEMBLY

Reassemble the front wheel in the reverse order of removal and disassembly.

Pay attention to the following points :

■ WHEEL BEARING

- Apply SUPER GREASE “A” to the wheel bearings.

 SUPER GREASE “A”

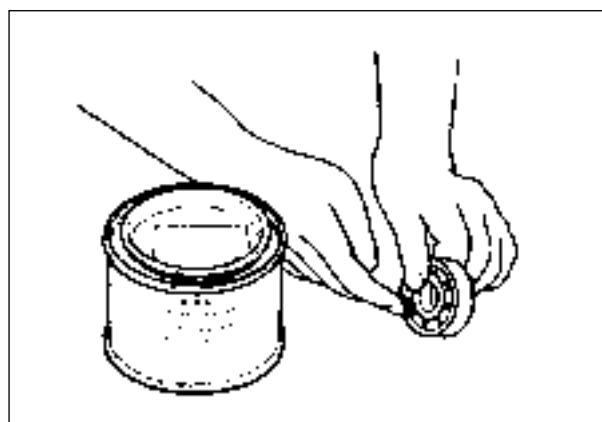

- Install the wheel bearings as follows by using the special tools.

 Steering race installer : 09941-34513

CAUTION

First install the right wheel bearing, then install the left wheel bearing.

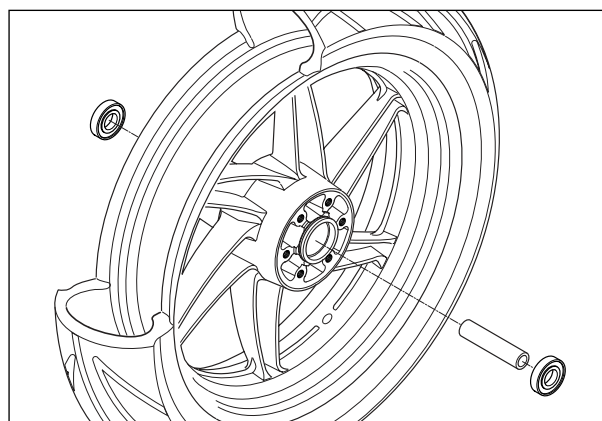

■ BRAKE DISC

Make sure that the brake disc is clean and free of any greasy matter.

- Apply THREAD LOCK “1324” to the disc mounting bolts and tighten them to the specified torque.

 Brake disc bolt

: 18~28 N · m (1.8 ~2.8 kg · m)

 THREAD LOCK “1324”

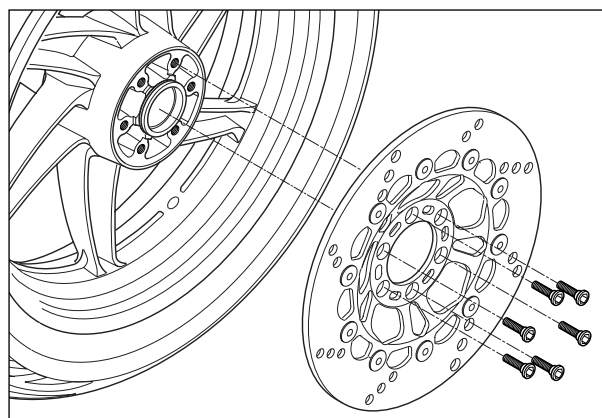

6-5 CHASSIS

- Tighten the front axle bolt ① and axle pinch bolt ② to the specified torque.

☑ **Front axle bolt : 50~80 N · m (5.0 ~8.0 kg · m)**
Front axle pinch bolt
: 15~25 N · m (1.5 ~2.5 kg · m)

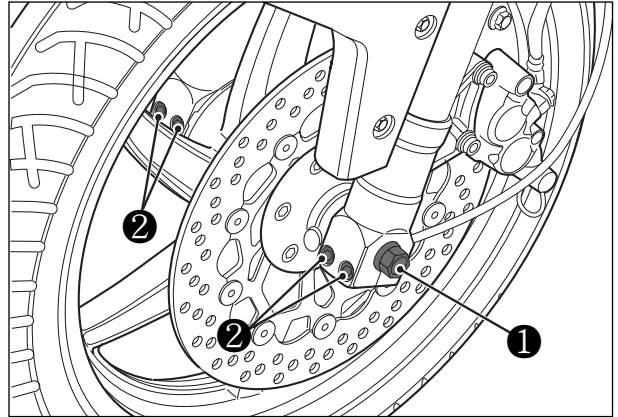

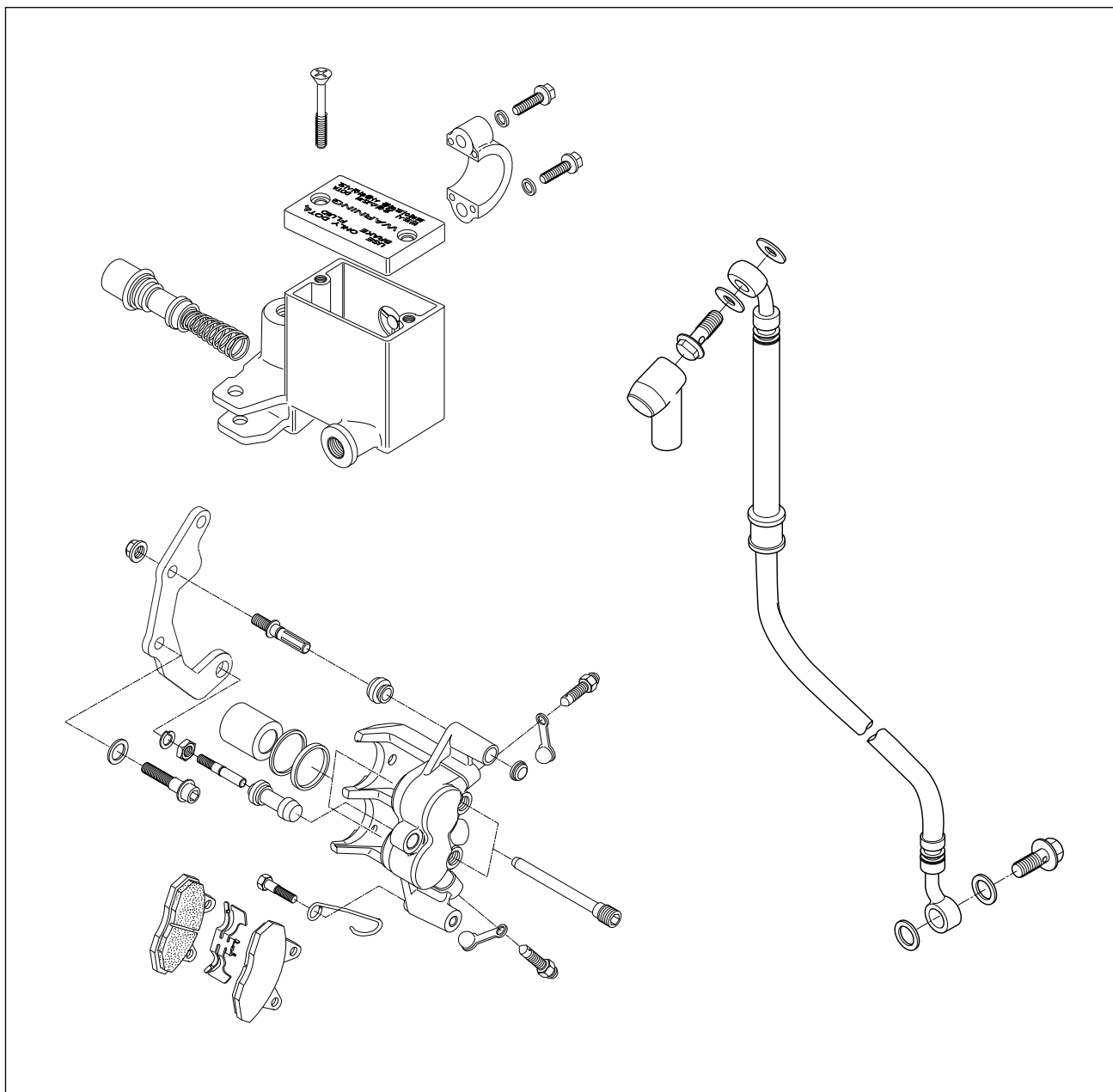
FRONT BRAKE**⚠ WARNING**

- ❖ Do not mix with brake fluid of different brand.
- ❖ Do not use a brake fluid kept in an open container or stored for long period of time.
- ❖ To store brake fluid, make sure to seal the container and keep it in a safe place to be out of reach of children.
- ❖ When filling brake fluid, take care not to allow water or dirt to enter the system.
- ❖ To wash the brake system parts, use brake fluid and not any other material.
- ❖ Do not allow dirt and fluid to contact the brake disc or pad.

⚠ CAUTION

Do not allow brake fluid to contact the paint surface, plastic or rubber parts, or its chemical reaction can cause discoloration or crack.

⦿ **BRAKE FLUID REPLACEMENT**

- For replacing procedure of brake fluid : Refer to page 2-15

⦿ **BRAKE PAD REPLACEMENT**

- For replacing procedure of brake pad : Refer to page 2-14

⦿ **CALIPER DISASSEMBLY**

- Drain brake fluid. (Refer to page 2-15)

⚠ CAUTION

To prevent brake fluid from splashing on the parts nearby, cover the parts with cloth.

- Remove the union bolt ① and caliper mounting bolts ②.
- Remove the brake pad. (Refer to page 2-14)
- Remove the brake caliper holder ③.

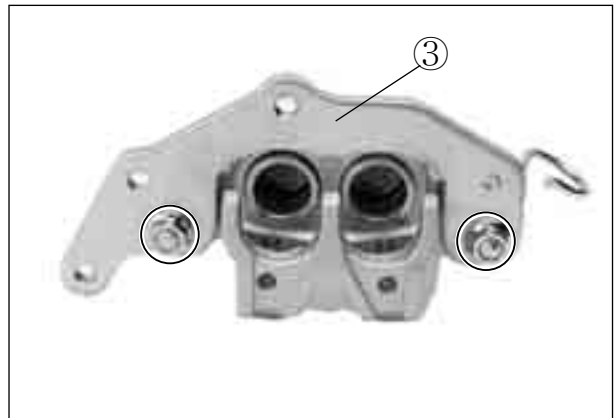
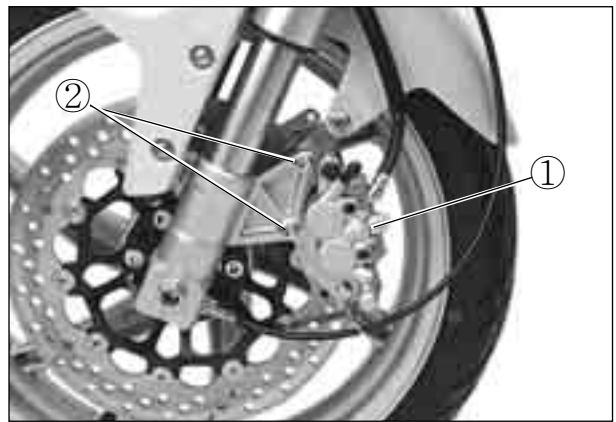

- Using an air gun, push out the caliper piston.

⚠ WARNING

- ❖ Place a rag over the piston to prevent it from popping out and flying and keeping hand off the piston.
- ❖ Be careful of brake fluid which can possibly splash.
- ❖ Do not use high pressure air but increase the pressure gradually.



- Remove the dust seal ① and piston seal ②.

 CAUTION
<ul style="list-style-type: none"> ❖ Care not to cause scratch on the cylinder bore. ❖ Do not reuse the piston seal and dust seal that have been removed.

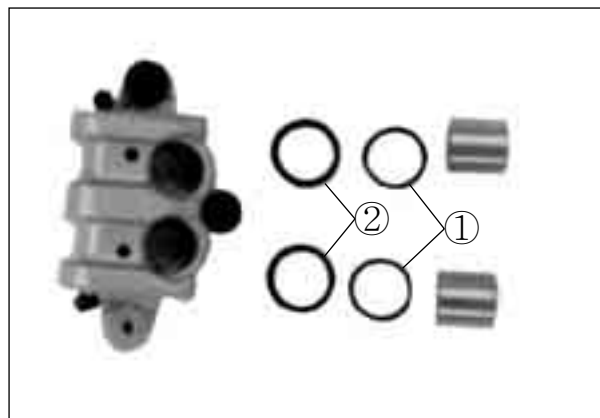

⊙ **CALIPER INSPECTION**

Inspect the caliper cylinder wall and piston surface for scratch, corrosion or other damages.
If any abnormal condition is noted, replace the caliper.



⊙ **CALIPER REASSEMBLY**

Reassemble the caliper in the reverse order of disassembly procedures and observe the following points.

 CAUTION
<ul style="list-style-type: none"> ❖ Wash the caliper components with fresh brake fluid before reassembly. Do not wipe off brake fluid after washing the components. ❖ Replace the piston seal and dust seal with new ones with brake fluid applied.

 **Brake fluid specification and classification**
: DOT 3 or DOT 4

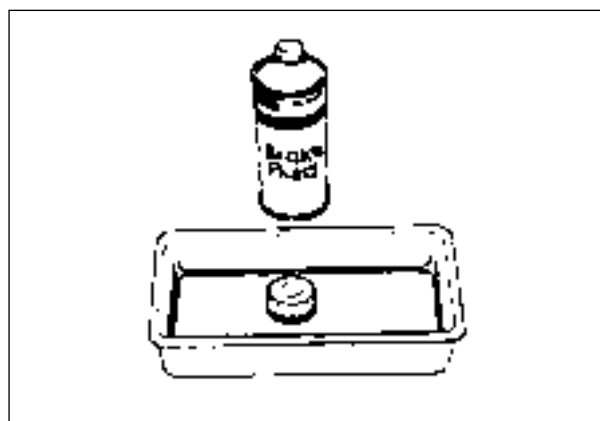

- Install the brake pad spring.

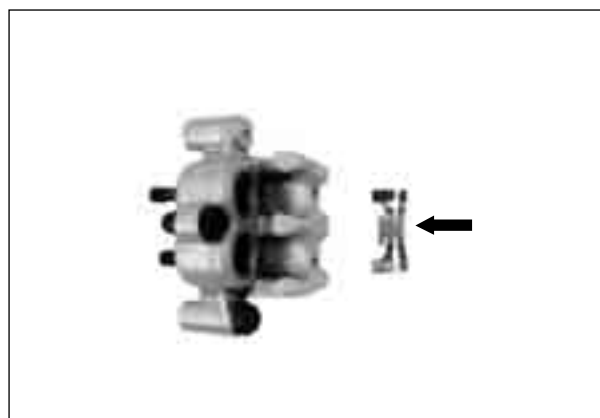

6-9 CHASSIS

- Apply SILICONE GREASE to the brake caliper holder.

 **SILICONE GREASE**

- Install the brake pads. (Refer to page 2-14)

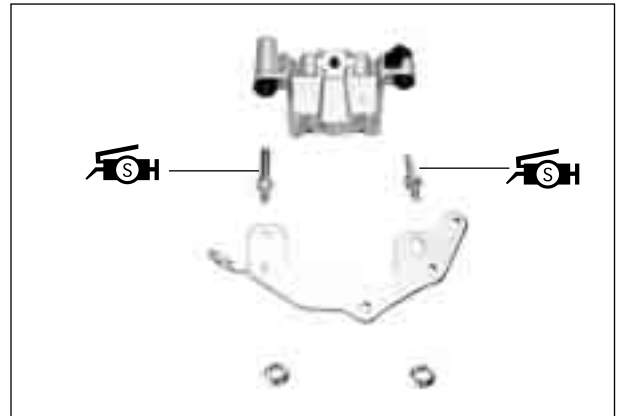

- Tighten the caliper mounting bolts ①.
- With the hose end seated to the stopper, tighten the union bolt ②

 **Front brake caliper mounting bolts**
:18~28 N · m (1.8~2.8 kg · m)

Front brake hose union bolts
:20~25 N · m (2.0~2.5 kg · m)

- Fill the system with brake fluid and bleed air. (Refer to page 2-16)
- Inspection after reassembly : Refer to page 2-14

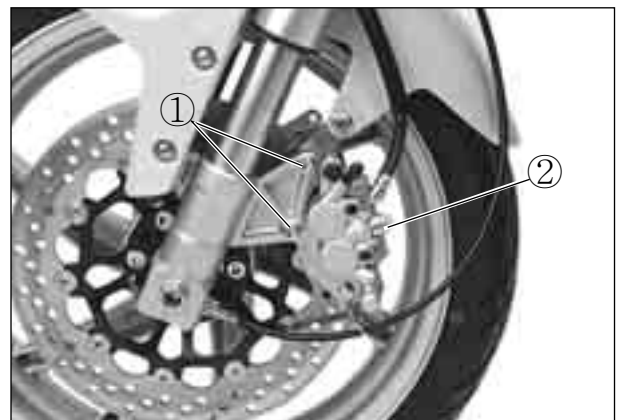

⊙ BRAKE DISC INSPECTION

Check the brake disc for damage or cracks. Measure the thickness using the micrometer.

Replace the brake disc if the thickness is less than the service limit or if damage is found.

 **Micrometer (0~25 mm) : 09900-20201**

Brake disc thickness	Service limit
	3.0 mm (0.12 in)

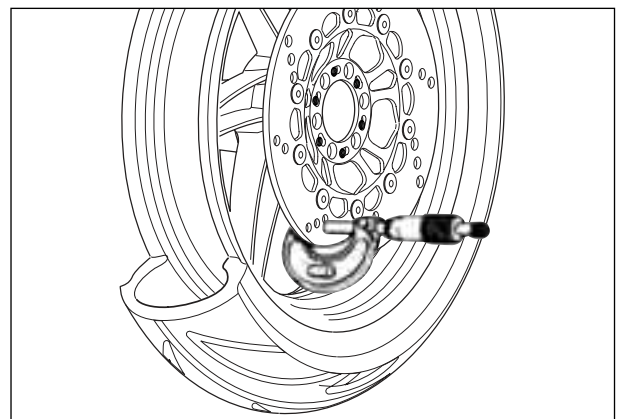

Measure the runout using the dial gauge.

Replace the brake disc if the runout exceeds the service limit.

 **Dial gauge : 09900-20606**
Magnetic stand : 09900-20701

Brake disc runout	Service limit
	0.3 mm (0.012 in)

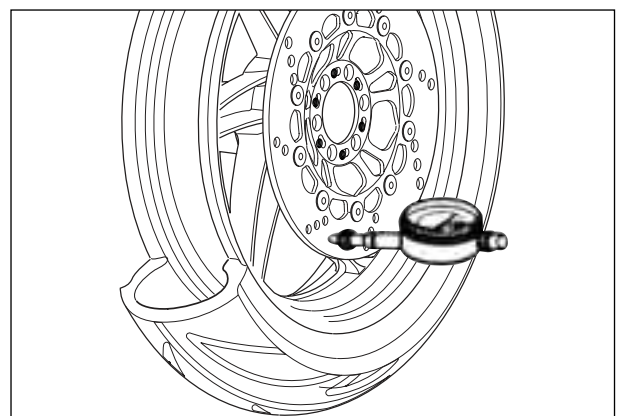

- If either measurement exceeds the service limit, replace the brake disc. (Refer to page 6-3)

⦿ **MASTER CYLINDER DISASSEMBLY**

- Drain brake fluid the master cylinder.
- Disconnect the brake lamp switch lead wire coupler.
- Remove the union bolt ①.

⚠ CAUTION

Place a rag under the union bolt so that brake fluid can not contact the parts.

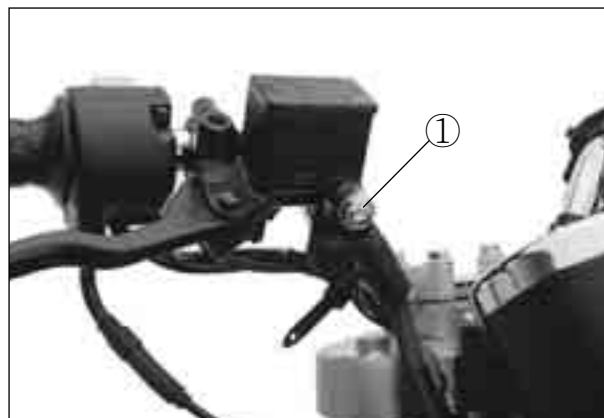

- Remove the two clamp bolts and take off the master cylinder.

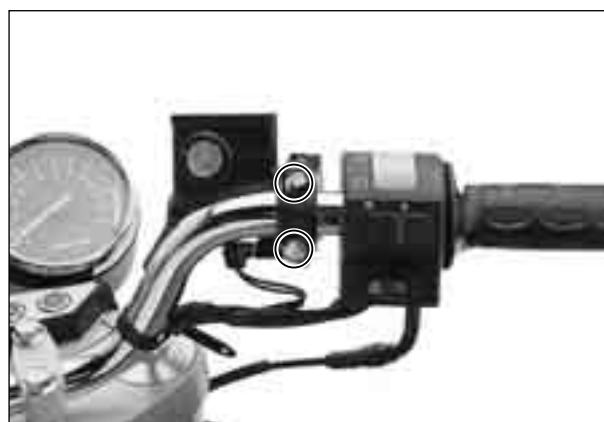

- Remove the two fitting screws and separate the cap and diaphragm.



- Detach the dust seal boot ② and remove the circlip.
- Pull out the piston/cup set ③ and spring ④.

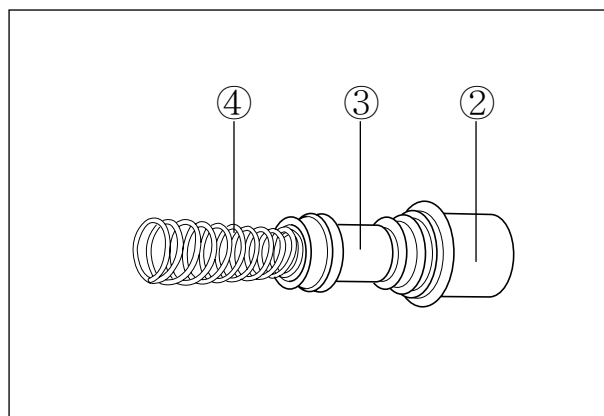

⦿ **MASTER CYLINDER INSPECTION**

Inspect the master cylinder bore for any scratches or other damage.

Inspect the piston surface for any scratches or other damage.

⦿ **MASTER CYLINDER REASSEMBLY**

Reassemble the master cylinder in the reverse order of disassembly.

Pay attention to the following points :

 **CAUTION**

- ❖ Wash the master cylinder components with new brake fluid before reassembly.
- ❖ When washing the components, use the specified brake fluid. Never use different types of fluid or cleaning solvents such as gasoline, kerosine, etc.



Specification and Classification

: DOT 3 or DOT 4

NOTE

When installing the circlip, make sure that the sharp edge of the circlip faces outside.

- When remounting the master cylinder to the handlebars, first tighten the clamp bolts for upside as shown.

 **WARNING**

Bleed air from the brake fluid circuit after reassembling master cylinder.(See page 2-16)

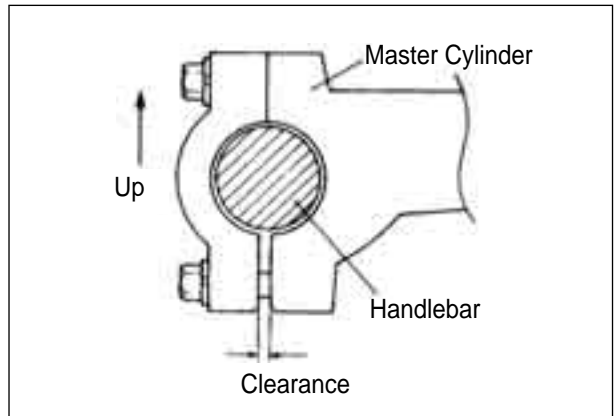
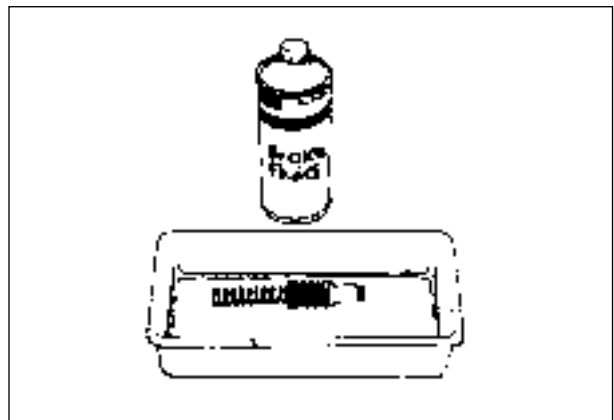
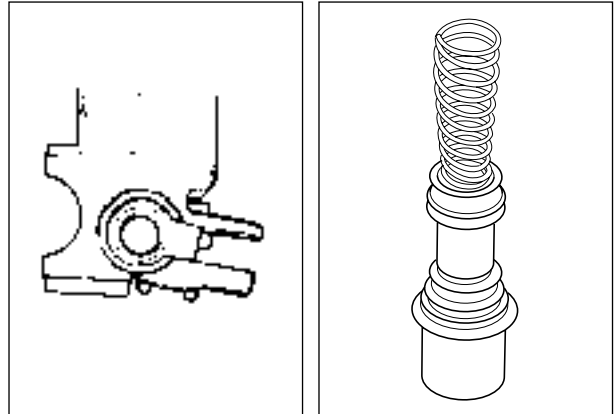

HANDLEBARS

⊙ HANDLEBARS RIGHT SIDE PARTS REMOVAL

- Remove the right handlebar switches.
- Disconnect the brake lamp switch lead wires and remove the master cylinder. (Refer to page 6-10)
- Remove the handlebar balancer ① and grip ②.

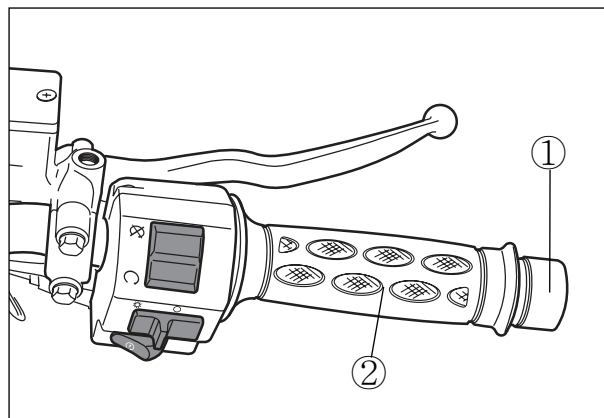

⊙ HANDLEBARS LEFT SIDE PARTS REMOVAL

- Remove the left handlebar switches.
- Remove the handlebar balancer ③ and grip ④.
- Remove the clutch lever holder.

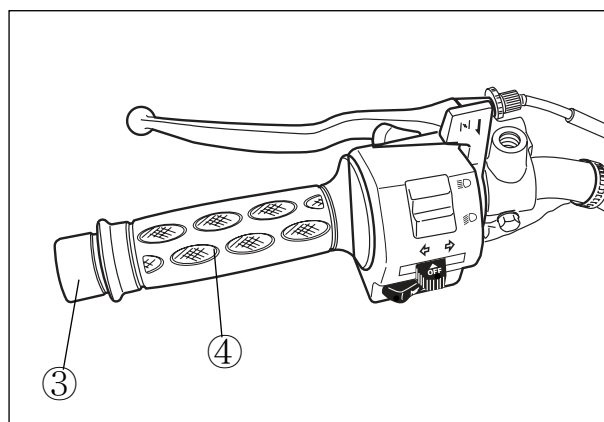

- Remove the clamp bolts and detach the handlebar holders.
- Remove the handlebar.



⊙ REMOUNTING

Perform the remounting work in the reverse order of the removal procedures while observing the following instructions.

- Install the handlebars with the punch mark ⑤ aligned with the handlebar clamp as shown.
- Tighten the handlebar clamp bolts to the specified torque.



Handlebar clamp bolts

: 18~28 N · m (1.8 ~2.8 kg · m)



NOTE

The gap ① between the handlebar clamp and holder should be even.

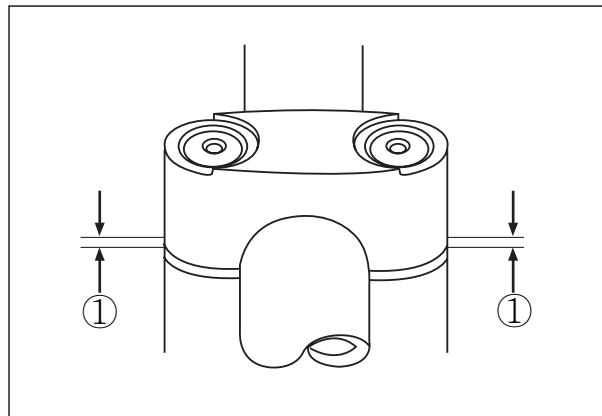

- Align the mating face of clutch lever holders with the respective punch marks and tighten the bolt.
- Install the brake master cylinder. (Refer to page 6-11).
- Apply SUPER GREASE “A” to the throttle cables and assemble them.

 SUPER GREASE “A”



FRONT FORK (『 Comet 250 』)

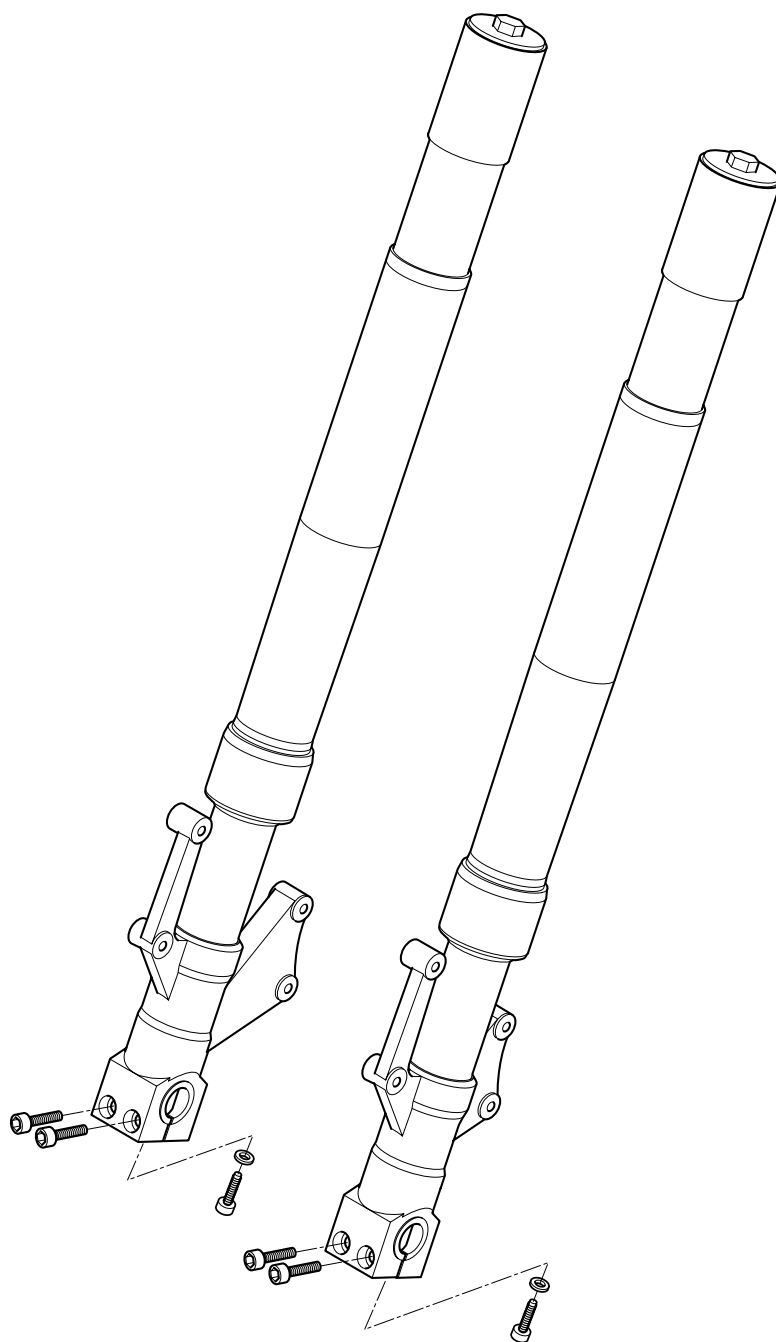

⊙ **REMOVAL AND DISASSEMBLY**

- Take off the front wheel. (See page 6-2)



- Loosen the front fork upper and lower clamp bolts.
- Remove the front brake hose clamp.
- Pull down right and left front forks.



- Remove the front fork cap, O-ring ①, and seat lever.

 CAUTION
❖ To remove the O-ring ①, it will be necessary to push the seat lever ② inwards, to remove the spring pressure from the O-ring.
❖ The removed O-ring ① should be replaced with a new one.

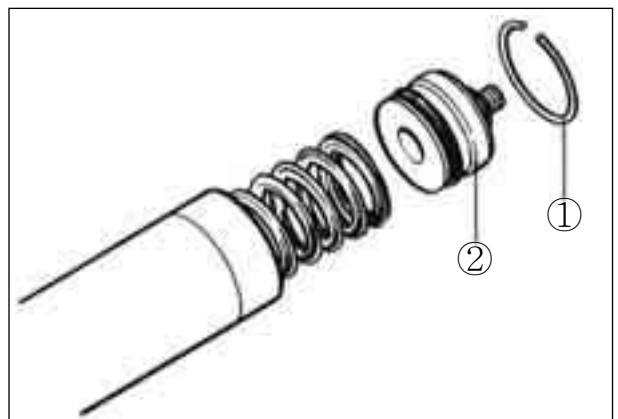

- Straighten the fork and stroke it several times to remove the oil.
- Hold the fork inverted for a few minutes.

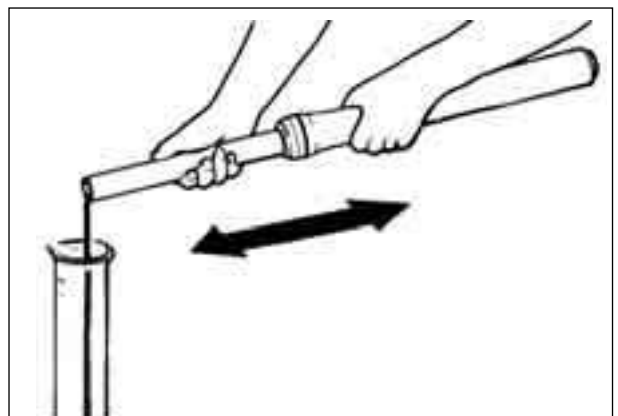

- Remove the damper rod bolt by using the special tool.



“T” Handle : 09940-34520

“D” Attachment : 09940-34561

“T” Type hexagon wrench (6mm)

: 09914-25811

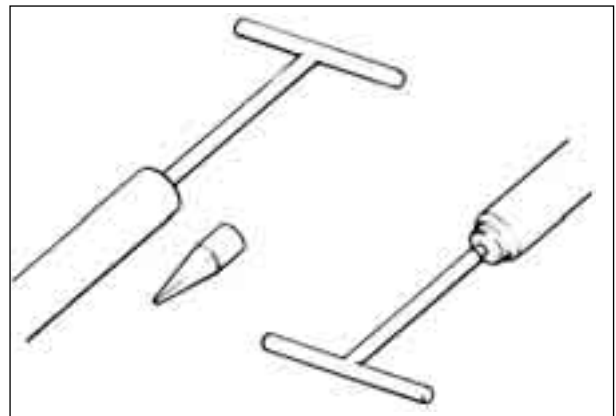

- Separate the inner tube from outer tube.
- Remove oil lock piece and damper rod with rebound spring.

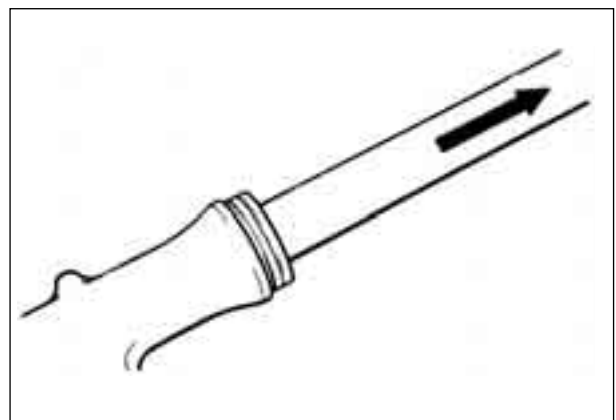

- Remove the snap ring by using the snap ring plier.

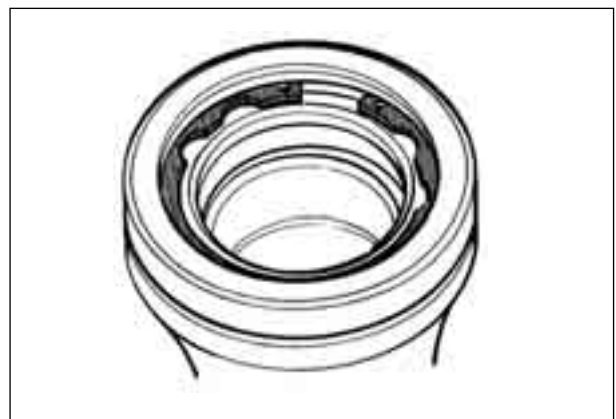

- Remove the oil seal by using the special tool.



Oil seal remover : 09913-50121

CAUTION

The oil seal removed should be replaced with a new one.

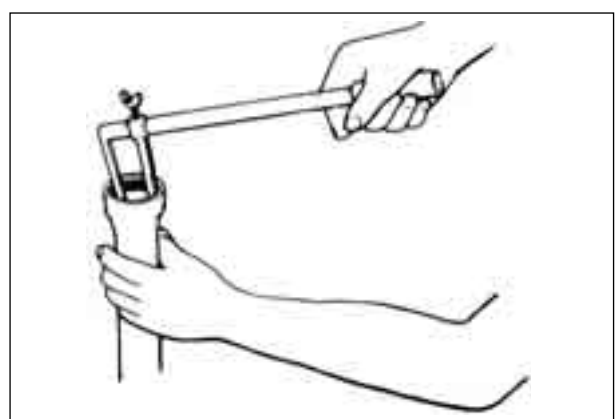

⦿ **INSPECTION**

■ **DAMPER ROD RING**

Inspect the damper rod ring for wear and damage.

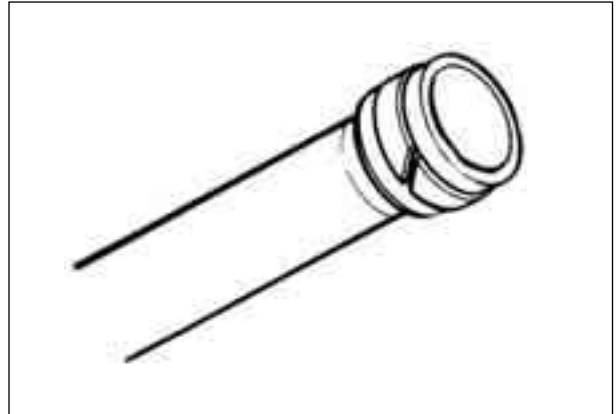

■ **INNER TUBE AND OUTER TUBE**

Inspect the inner tube and outer tube sliding surfaces for any scuffing or flaws.

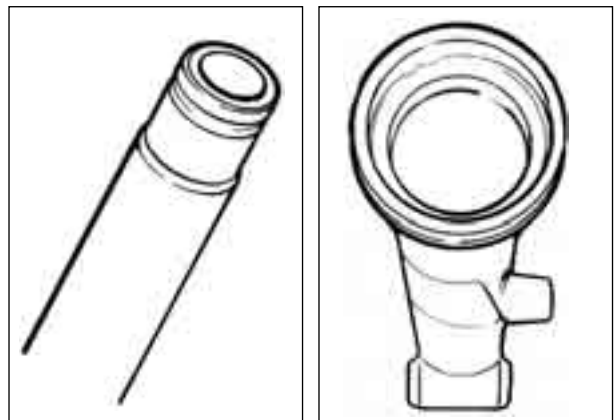

■ **FORK SPRING**

Measure the fork spring free length (A). If it is shorter than the service limit, replace it.

Fork spring free length (A)	Standard
	433.3 mm (17.1 in)

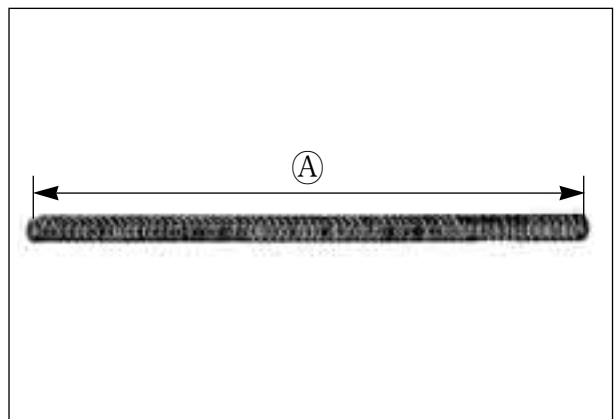

■ **REASSEMBLY**

Reassemble and remount the front fork in the reverse order of disassembly and removal, and also carry out the following steps :

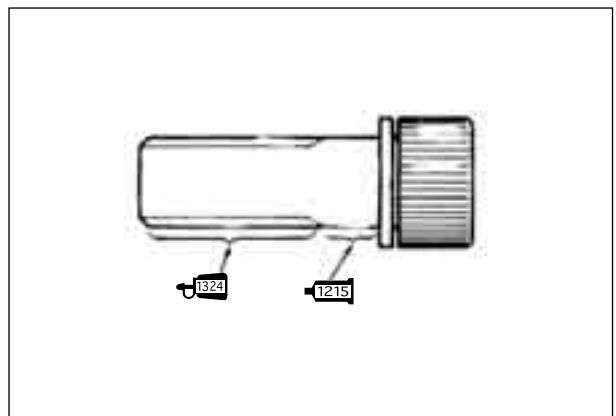

■ DAMPER ROD BOLT

- Apply Bond “1215” and Thread Lock “1324” to the damper rod bolt and tighten the bolt with specified torque by the Special tool

🔧¹²¹⁵ Bond “1215”

🔧¹³²⁴ Thread Lock “1324”

🔧^{TOOL} “T” Handle : 09940-34520

“D” Attachment : 09940-34561

“T” Type hexagon wrench (6mm) : 09914-25811

🔧 Front fork damper rod bolt
: 30~40 N · m (3.0~4.0 kg · m)

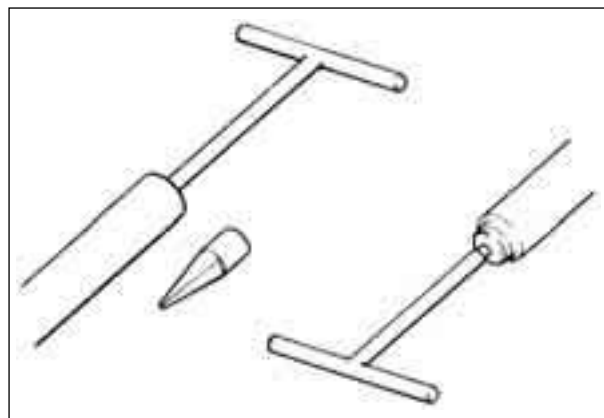

■ OIL SEAL

Install the oil seal to the outer tube by using the special tool as shown.

🔧^{TOOL} Fork oil seal installer : 09940-50112

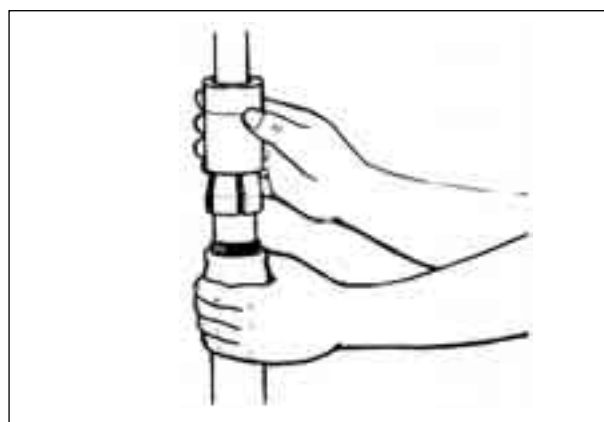

■ FORK OIL

- For the fork oil, be sure to use a front fork oil whose viscosity rating meets specifications below.

🔧^{FORK} Front fork oil specification : TELUS #22

Front fork oil capacity	Each leg
	400 ± 2.5cc

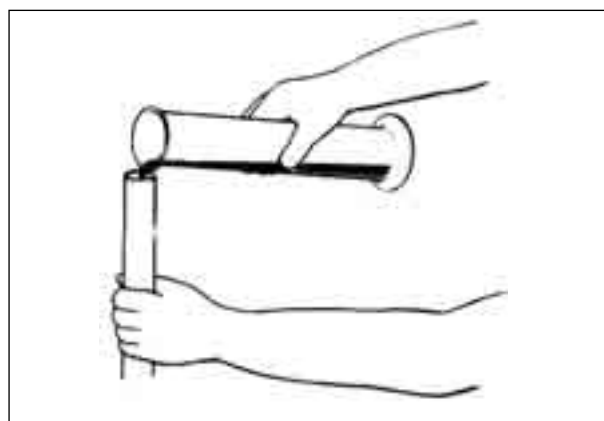

- Hold the front fork vertical and adjust the fork oil level with the special tool.

Front fork oil level	Standard
	146 mm (5.8 in)

🔧^{TOOL} Front fork level gauge : 09943-74111

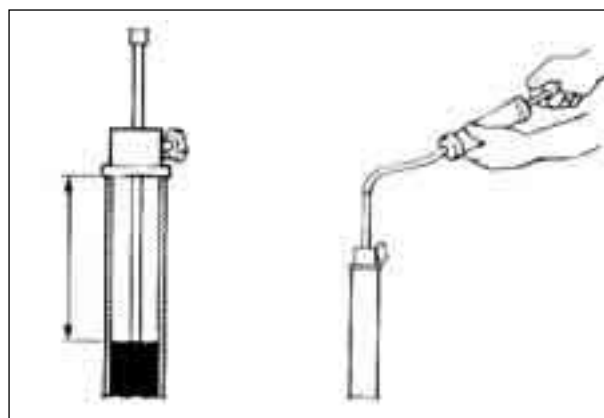

⚠ CAUTION

When adjusting oil level, remove the fork spring and compress the inner tube fully.

■ **FORK SPRING**

The narrow pitch side of spring face to the upper side when installing the front fork spring.

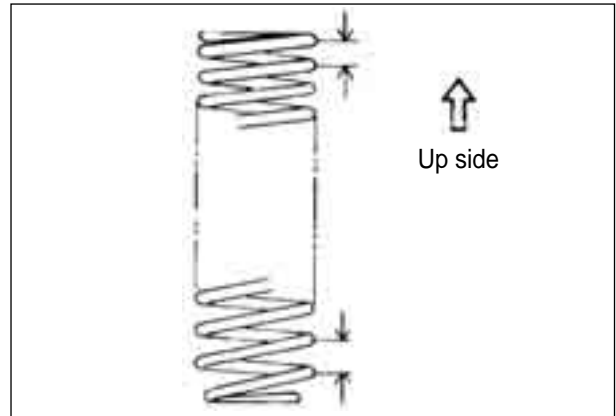

■ **STOPPER RING**

● To install a new stopper ring, it will be necessary to push the spring seat inward.

CAUTION

Always use a new stopper ring.
After installing a stopper ring, always insure that it is completely seated in its groove and securely fitted.

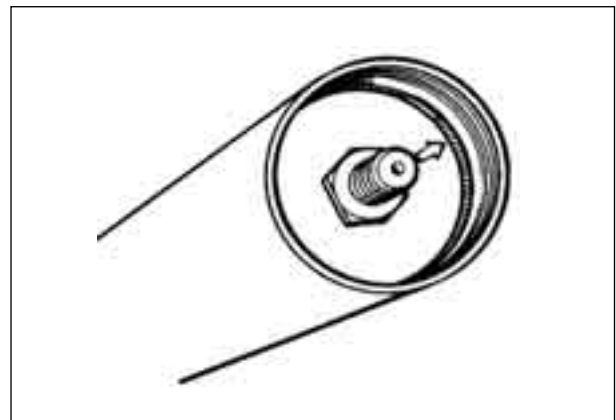

■ **REMOUNTING**

● Tighten the upper and lower clamp bolts.

🔧 Front fork upper clamp bolts : 22~35 N · m
(2.2~3.5 kg · m)

Front fork lower clamp bolts : 22~35 N · m
(2.2~3.5 kg · m)



FRONT FORK (『 Comet-125 』)

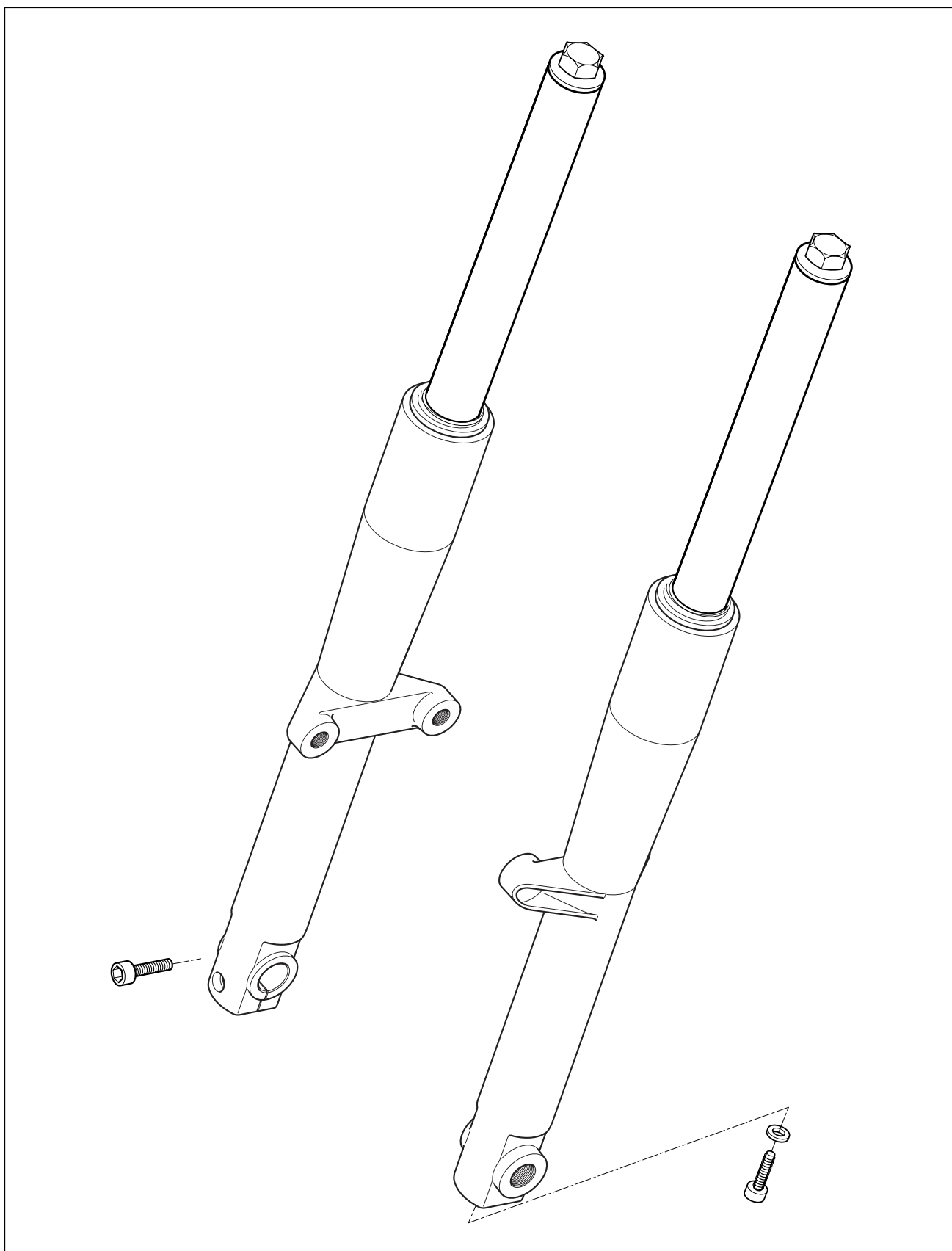

⦿ **DISASSEMBLY**

- Remove the front wheel. (Refer to page 6-2)
- Remove the brake caliper. (Refer to page 6-7)

⚠ CAUTION

Secure the brake caliper to the frame with a string etc., taking care not to bend the brake hose.

- Remove the front fender. (Refer to page 6-1)

- Remove the front fork after loosening the front fork upper ① and lower ② clamp bolts .

NOTE

Slightly loosen the front fork upper bolt ③ to facilitate later disassembly.

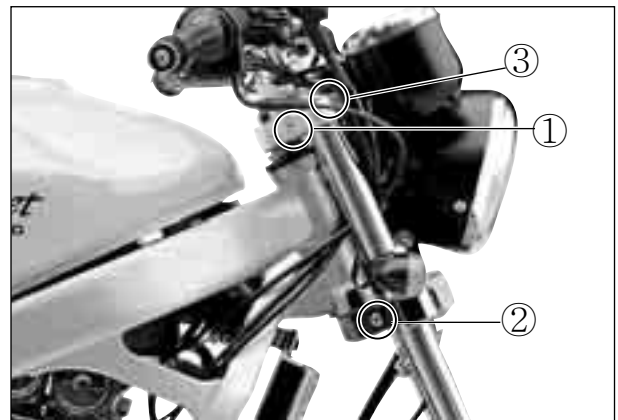

- Remove the front fork upper bolt ③, O-ring ④, front fork inner spacer ⑤ and spring guide ⑥.

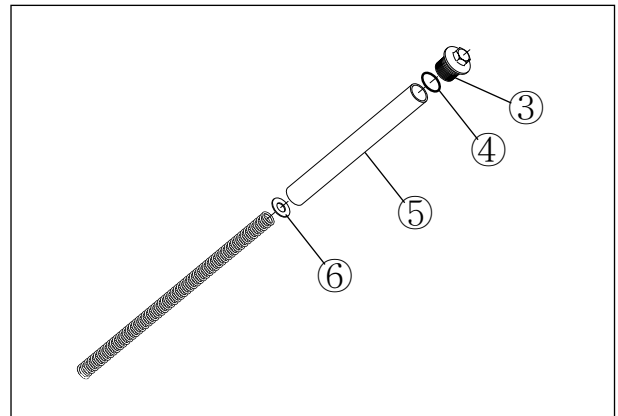

- Invert the front fork and stroke it several times to drain out the fork oil.
- Hold the front fork in the inverted position for a few minutes to allow the fork oil to fully drain.

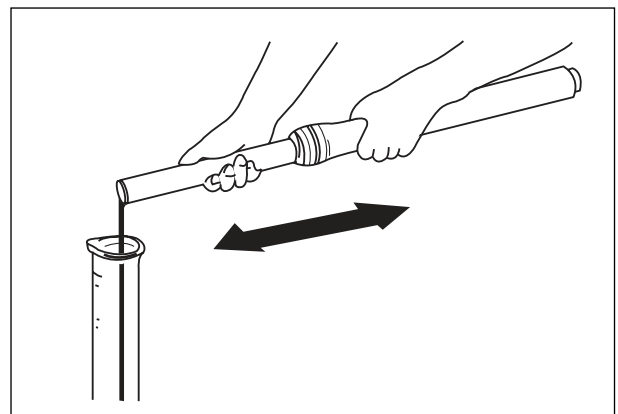

- With the damper rod held immovable, remove the damper rod bolt.
- Remove the damper rod ① and rebound spring ② from the inner tube.

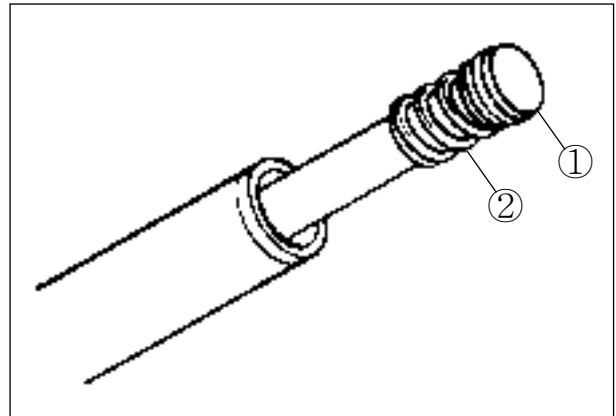

- Remove the dust seal ③ and oil seal stopper ring ④.

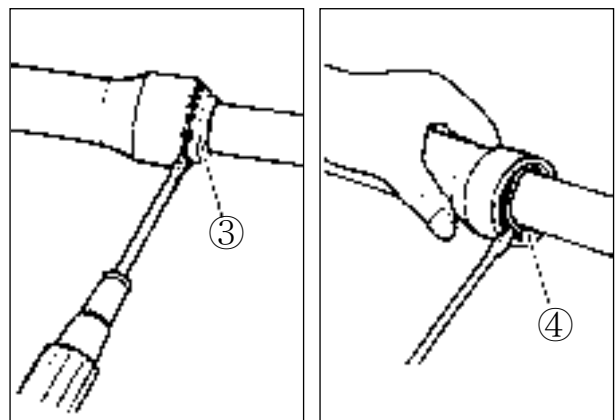

- Separate the inner tube from the outer tube.

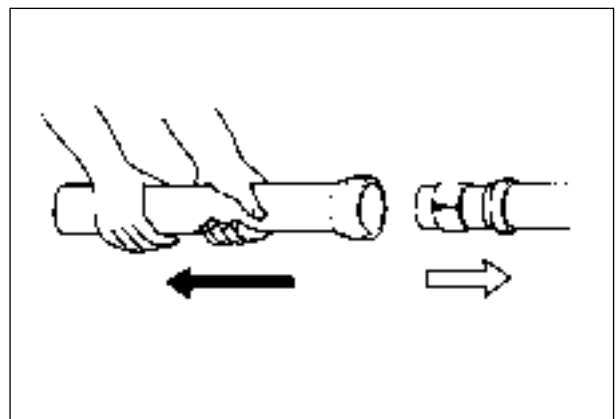

- Remove the following parts.
 - ⑤ Oil seal
 - ⑥ Slide metal
 - ⑦ Oil lock piece

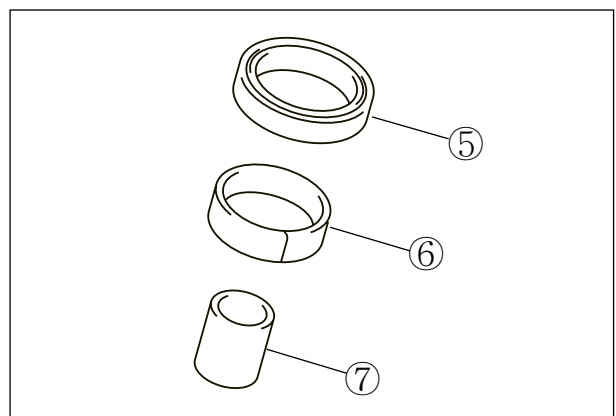

⚠ CAUTION

The removed oil seal and slide metal should be replaced with new ones.

⦿ **INSPECTION**

■ **FRONT FORK SPRING**

Measure the free length of the front fork spring (A).
If the length is found shorter than the service limit, replace the spring.

Fork spring free length (A)	Service limit
	354 mm (13.9 in)

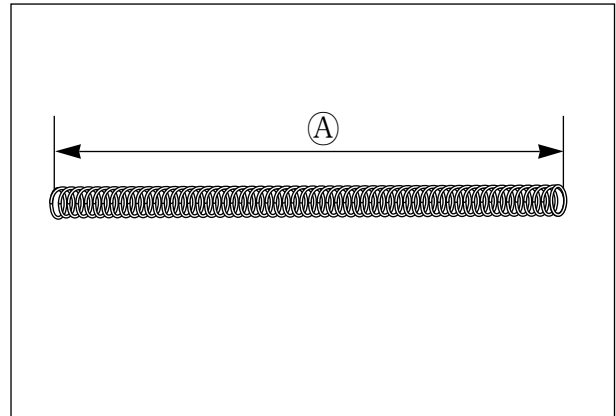

■ **INNER TUBE AND OUTER TUBE**

Check the sliding surface of the inner tube, outer tube and damper rod ring for scratch, wear, bending, or other abnormal condition.

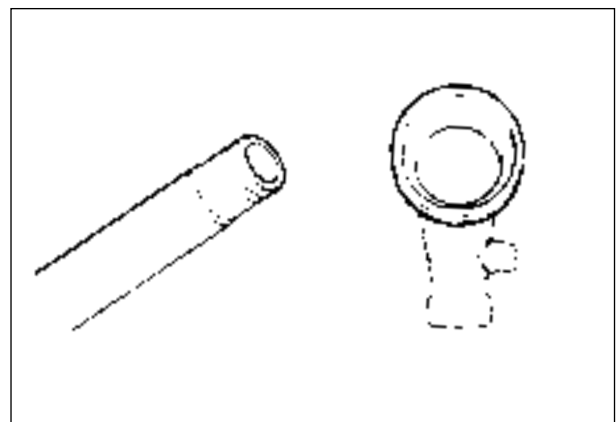

⦿ **REASSEMBLY**

Perform the reassembly and remounting work in the reverse order of the disassembly and removal procedures while observing the following instructions.

⚠ CAUTION

- ❖ Thoroughly wash all the component parts being assembled.
Insufficient washing can result in oil leakage or premature wear of the parts.
- ❖ When reassembling the front fork, use new fork oil.
- ❖ Use the specified fork oil for the front fork.
- ❖ When reassembling, replace the slide metals, oil seal, dust seal and damper rod bolt gasket with new ones.

● On the inner tube, assemble the following parts.

- ① Dust seal
- ② Oil seal stopper ring
- ③ Oil seal
- ④ Oil seal retainer
- ⑤ Slide metal
- ⑥ Guide bushing

⚠ CAUTION

To prevent the lip of oil seal (3) from being damaged, cover the inner tube with vinyl sheet (A) during installation.

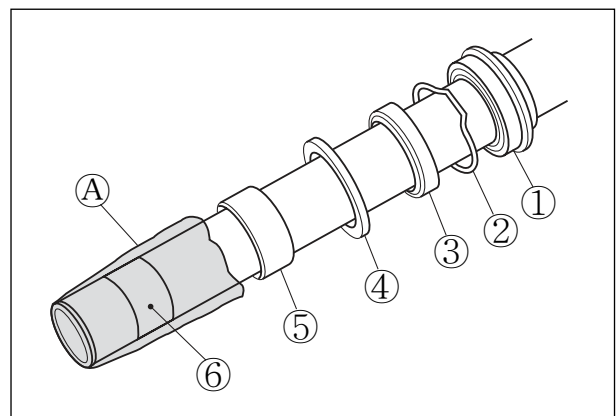

- With the oil lock piece fitted to the inner tube, assemble the inner tube to the outer tube.

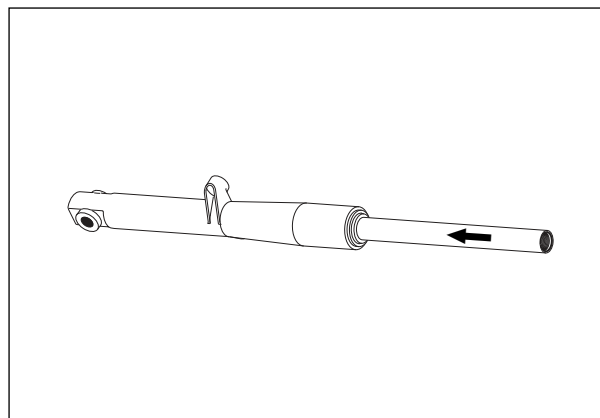

- Apply SUPER GREASE “A” to the lip of the oil seal (A) and install it into the outer tube using the front fork oil seal installer.

 SUPER GREASE “A”

 Front fork oil seal installer set

: 09940-52861

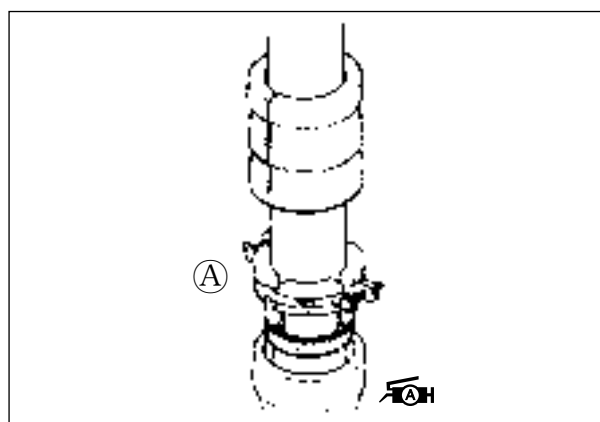

 **CAUTION**

Wash and clean the front fork oil seal installer before using. If dirt is on the installer, the inner tube may possibly be damaged during press-fitting work.

- Fit the stopper ring (2) and dust seal (1).

 **CAUTION**

Make sure that the stopper ring is securely fitted into the groove on the outer tube.

- ① Dust seal
- ② Oil seal stopper ring
- ③ Oil seal
- ④ Oil seal retainer
- ⑤ Slide metal

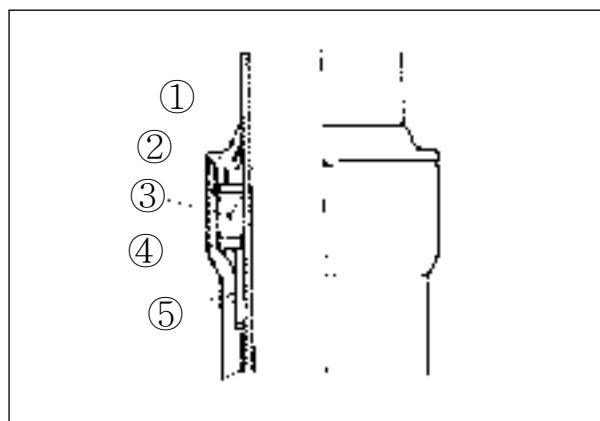

- Fit the rebound spring (7) on the damper rod (6) and install them together to the inner tube.

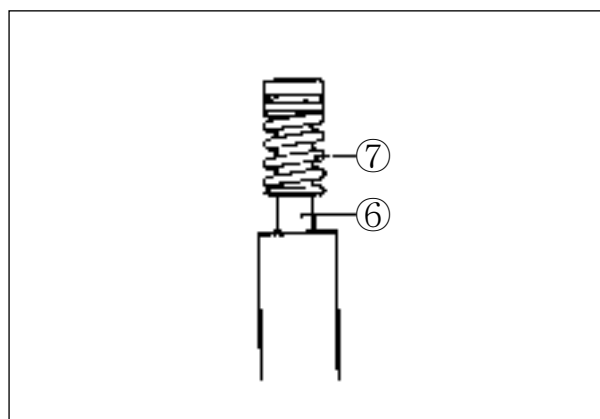

6-25 CHASSIS

- Apply THREAD LOCK “1324” to the damper rod bolt ②.
- With the damper rod held immovable, with the gasket ① fitted, tighten the damper rod bolt ②.

 **Front fork damper rod bolt**
: 30~40 N · m (3.0~4.0 kg · m)

 **THREAD LOCK “1324”**

CAUTION

Replace the gasket with a new one.

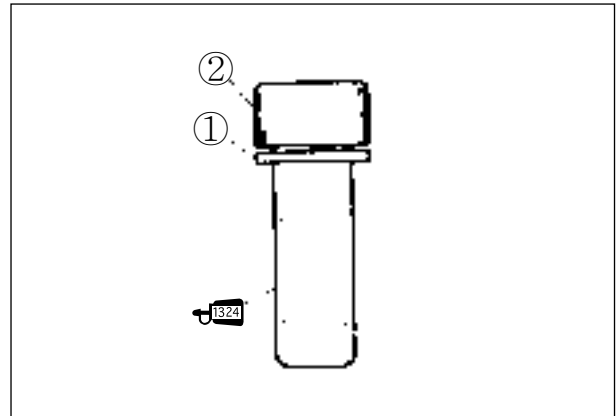

■ FRONT FORK OIL

- With the inner tube in fully compressed position, pour the specified amount of fork oil and stroke the tube several times to expel air.

 **Front fork oil specification : TELLUS #22**

Front fork oil capacity	Each leg
	262 cc

- With the front fork held in vertical position, compress the inner tube all the way.
- Wait until the fluid level stabilizes, measure and adjust the level to specification using the special tool.

Front fork oil level	Standard
	155 mm (6.1 in)

 **Front fork oil level gauge : 09943-74111**

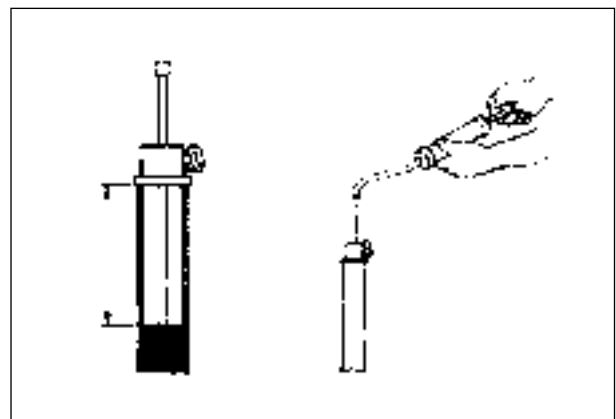
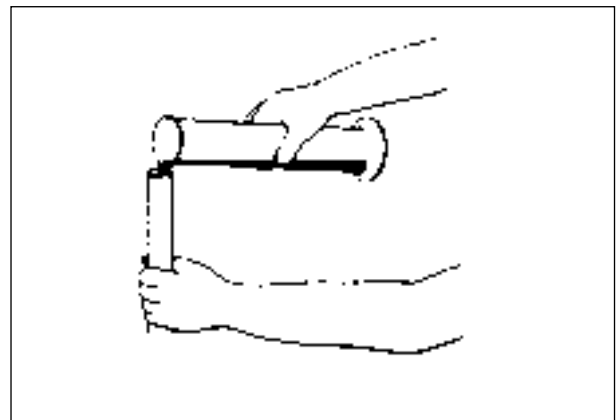

- Install the front fork spring ③.
- Install the spring guide ④, front fork inner spacer ⑤, and O-ring ⑥.

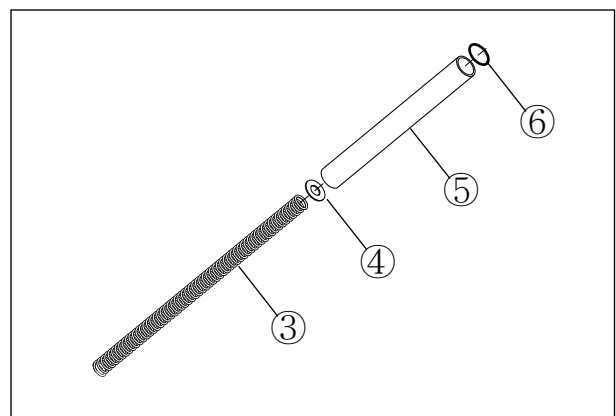

- Fit the O-ring to the front fork upper bolt and apply SUPER GREASE "A".

 SUPER GREASE "A"

 **CAUTION**

Use a new O-ring to prevent oil leakage.

- Install the front fork to the motorcycle.
- Align the upper surface of the inner tube with the upper surface of the steering stem upper bracket.

- Tighten the front fork lower clamp bolts ① and front fork upper bolts ② to the specified torque.
- Tighten the front fork upper clamp bolts ③ to the specified torque.

 **Front fork upper clamp bolt**
: 22~35 N · m (2.2~3.5 kg · m)

Front fork lower clamp bolt
: 22~35 N · m (2.2~3.5 kg · m)

Front fork upper bolt
: 22~30 N · m (2.2~3.0 kg · m)

- Install the front fender and tighten the mounting bolts temporarily.
- Install the front brake caliper. (Refer to page 6-8)
- Install the front wheel. (Refer to page 6-4)
- Move the front fork up and down several times.
- Tighten the front fender mounting bolts securely.

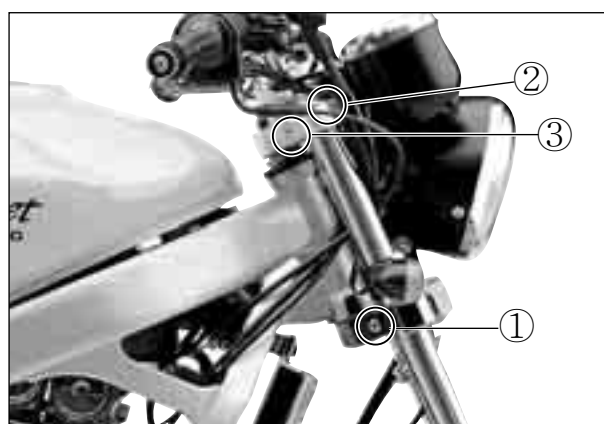

STEERING

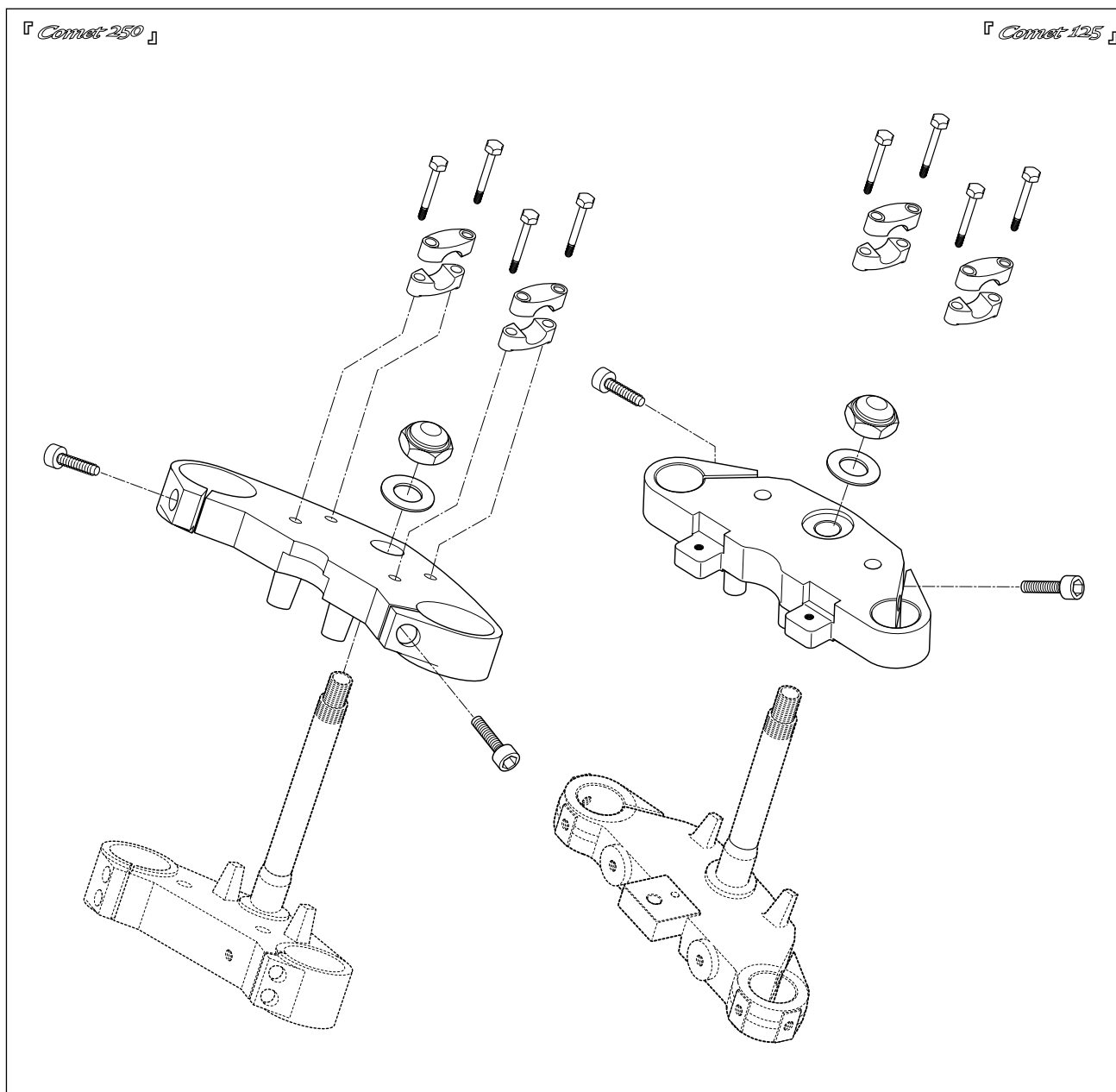

⊙ REMOVAL AND DISASSEMBLY

- Take off the front wheel. (See page 6-2)
- Remove the four bolts and front fender.
- Take off the front fork. (See page 6-15, 6-21)



- Remove the handlebar clamp bolts.
- Remove the steering stem head nut ① and take off the steering stem upper bracket ②.

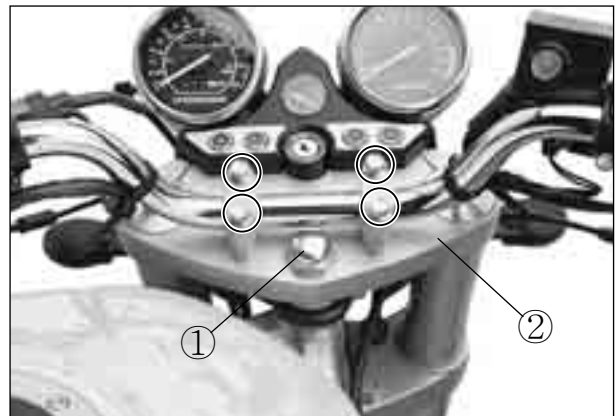

- Remove the steering stem nut ③ and draw out the steering stem.

 **Clamp wrench : 09940-10122**

- Take off the steering stem lower bracket ④.

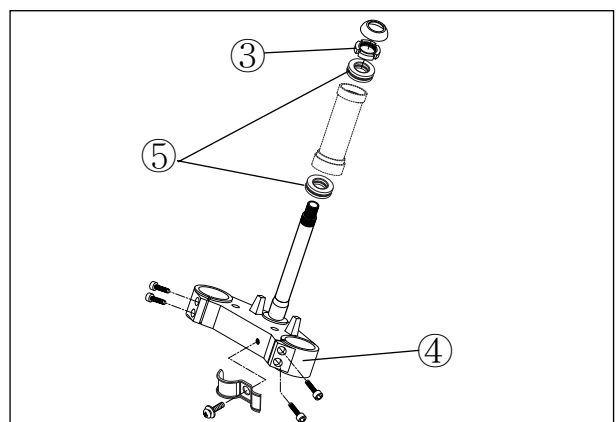

CAUTION

Hold the steering stem lower bracket by hand to prevent from falling.

- Remove the upper and lower bearing ⑤.
- Remove the outer race fitted on the steering stem. This can be done with a chisel.

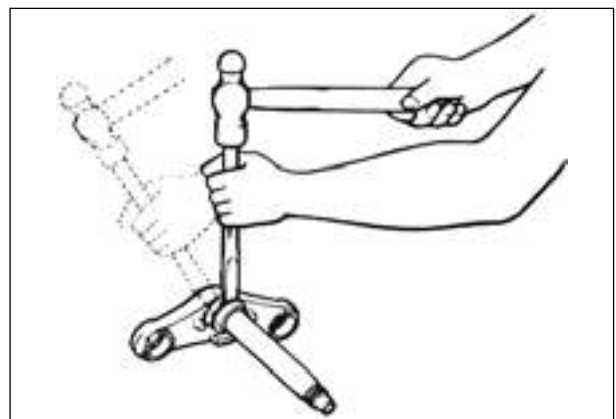

- Draw out the two inner races fitted to the top and bottom ends of the head pipe.

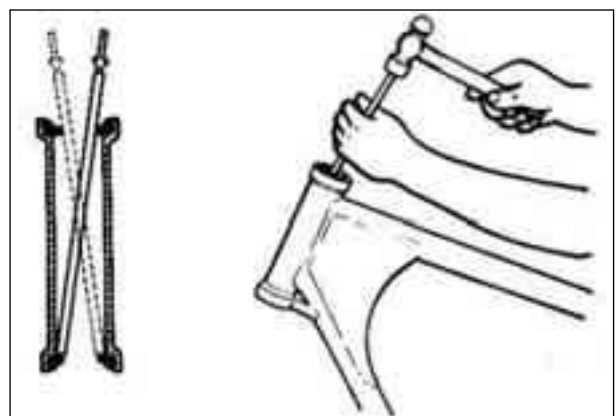

⊙ **INSPECTION**

Inspect and check the removed parts for the following abnormalities.

- Handlebar distortion.
- Handlebar clamp wear.
- Abnormality operation of bearing.
- Worn or damaged races.
- Distortion of steering stem.

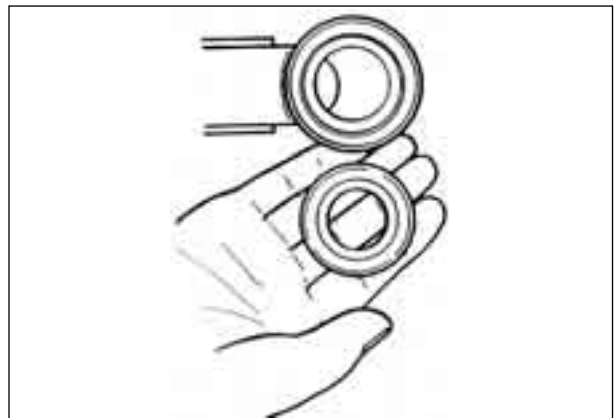

⊙ **REASSEMBLY**

Reassemble and remount the steering stem in the reverse order of disassembly and removal, and also carry out the following steps :

- Apply SUPER GREASE “A” to the upper bearing and lower bearing ①.

 **SUPER GREASE “A”**

- Tighten the steering stem nut ② with the special tool.

 **Clamp wrench : 09940-10122**

 **Steering stem nut : 80~100 N · m (8.0~10.0kg · m)**

- Turn the steering stem right and left, lock-to-lock, five or six times.
- Tighten the steering stem head nut to the specified torque.

 **Steering stem head nut : 80~100 N · m
(8.0~10.0 kg · m)**

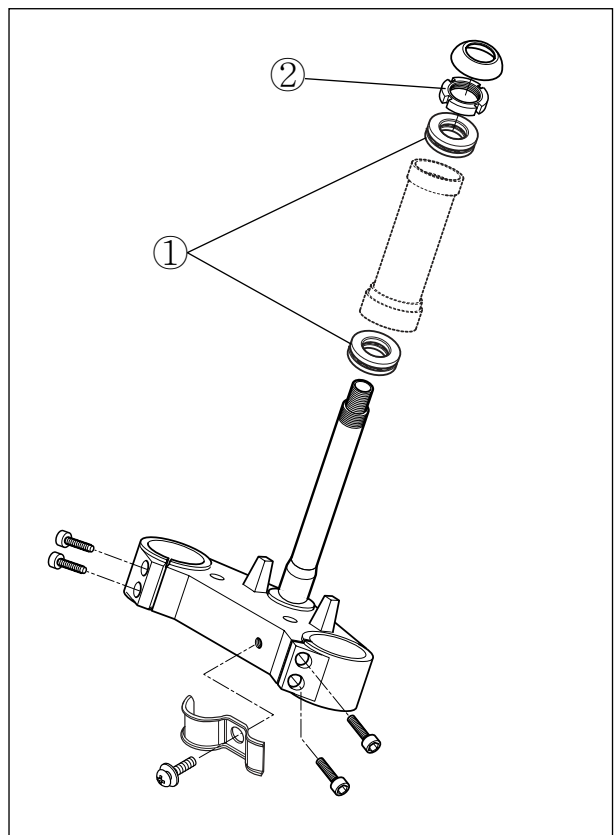

 **CAUTION**

After performing the adjustment and installing the steering stem upper bracket, rock the front wheel assembly forward and backward to ensure that there is no play and that the procedure was accomplished correctly. If play is noticeable, re-adjust the steering stem nut.

- Set the handlebars to match its punched mark to the mating face of the holder.
- Secure the each handlebar clamp bolts in such a way that the clearances ahead of and behind the handlebars should be equalized.

 **Handlebar clamp bolts
: 18~28 N · m (1.8~2.8 kg · m)**



REAR WHEEL

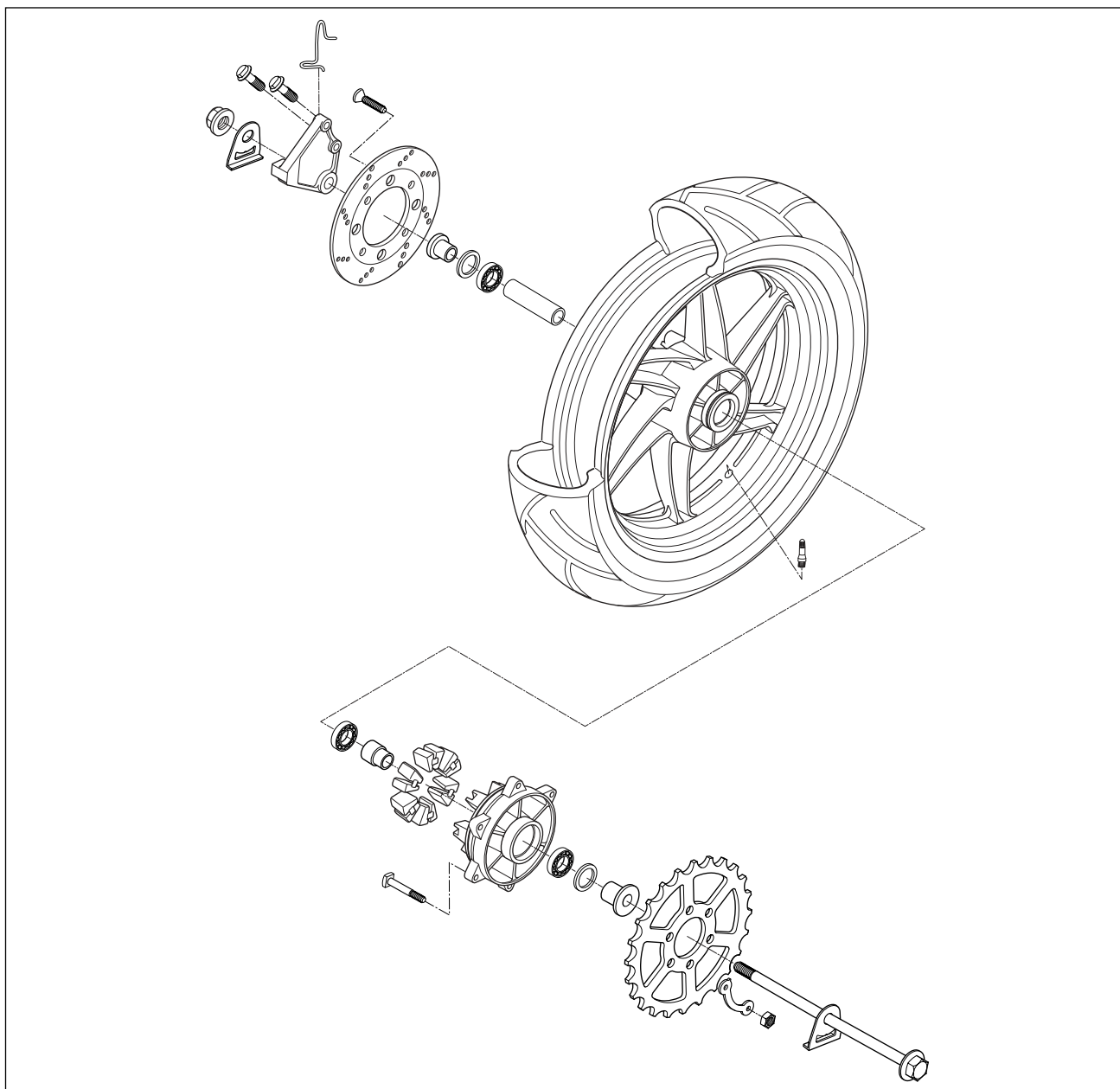

⊙ REMOVAL

- Raise the rear wheel off the ground with a jack or block.
- Loosen the drive chain adjuster ①, right and left.
- Disengage the drive chain from the rear sprocket.



6-31 CHASSIS

- Remove the rear wheel by removing the rear axle ①.



- Remove the brake disc.

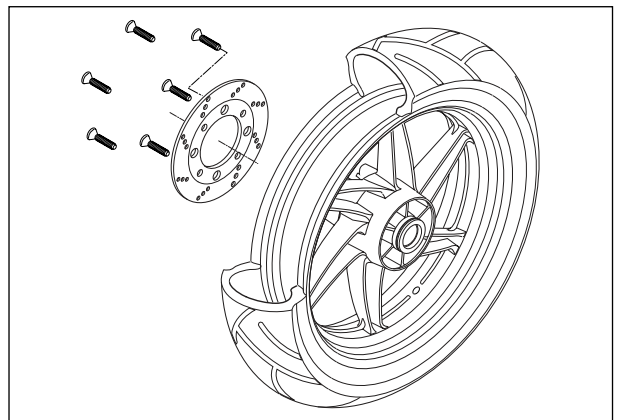

- Remove the spacer ②.
- Remove the rear sprocket ③ with mounting drum ④ from the rear wheel.

NOTE

Before separating the rear sprocket and mounting drum, slightly loosen the rear sprocket bolts.

- Remove the rear wheel shock absorber ⑤.
- Remove the rear sprocket ③ from the rear sprocket mounting drum.

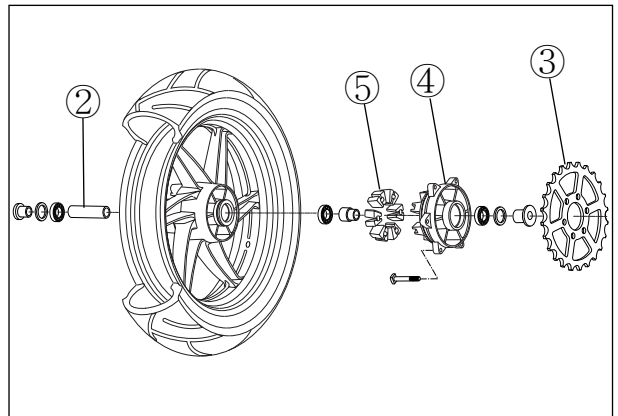

■ WHEEL BEARING REMOVAL

- Remove the bearing by using the special tool.

 Wheel bearing remover : 09941-50111

CAUTION

The removed bearing should be replaced with new one.

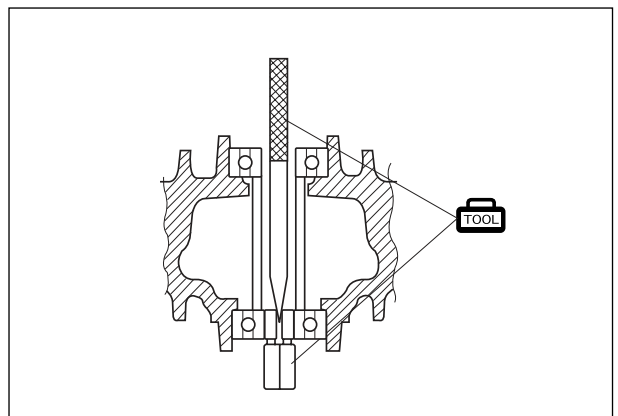

⦿ INSPECTION

WHEEL AXLE : Refer to page 6-3

WHEEL : Refer to page 6-3

WHEEL BEARING : Refer to page 6-3

TIRE : Refer to page 2-18

■ REAR WHEEL SHOCK ABSORBER

Inspect the rear wheel shock absorber for wear and damage. Replace the rear wheel shock absorber if there is anything unusual.

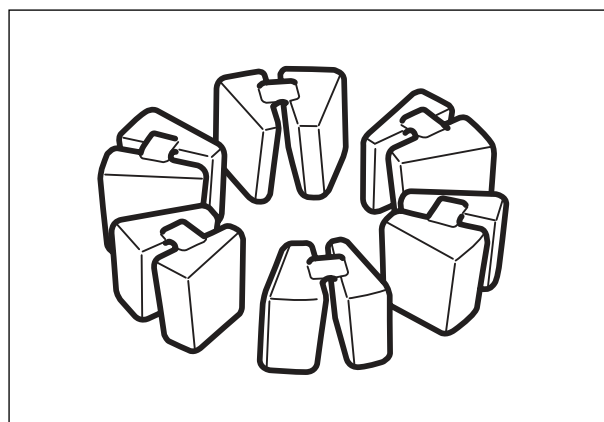

■ SPROCKET

Inspect the sprocket's teeth for wear. If they are worn, replace the sprocket and drive chain as a set.

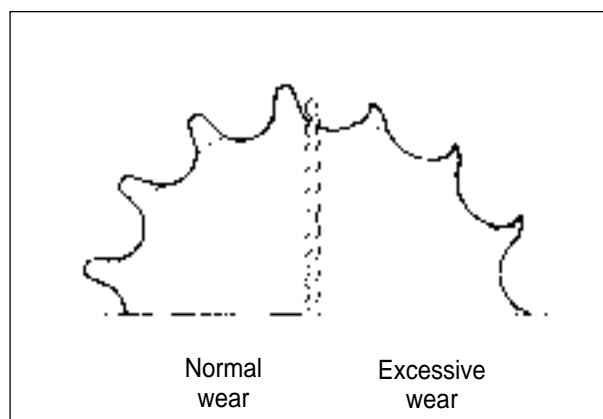

⦿ REASSEMBLY

Reassemble the rear wheel and rear brake in the reverse order of disassembly.

Pay attention to the following points :

- Tighten the rear sprocket nuts to the specified torque.



Rear sprocket nut

: 20~30 N · m (2.0~3.0 kg · m)

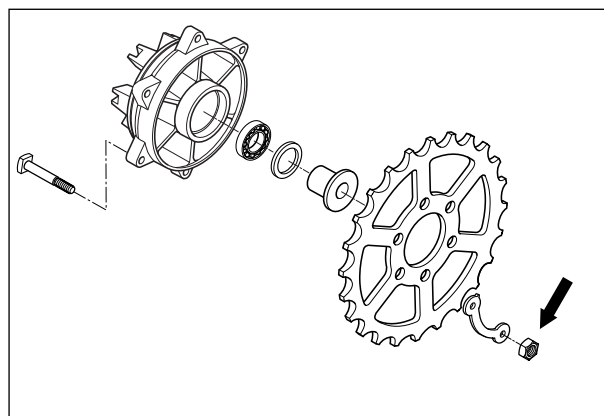

6-33 CHASSIS

- Install the rear wheel.
After installing the drive chain to the rear sprocket, adjust the drive chain.
- Tighten both chain adjusting nuts securely.

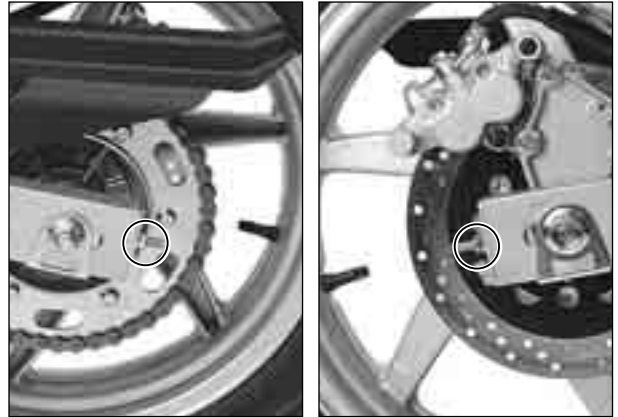

- Tighten the rear axle nut to the specified torque.
 Rear axle nut : 90~140 N · m (9.0~14.0 kg · m)



6-35 CHASSIS

- ⊙ Brake fluid replacement : Refer to page 2-15
- ⊙ Brake pad replacement : Refer to page 2-14
- ⊙ Disassembly of caliper : Refer to page 6-7
- ⊙ Inspection of caliper : Refer to page 6-8
- ⊙ Reassembly of caliper : Refer to page 6-8
- ⊙ Inspection of brake disc : Refer to page 6-9

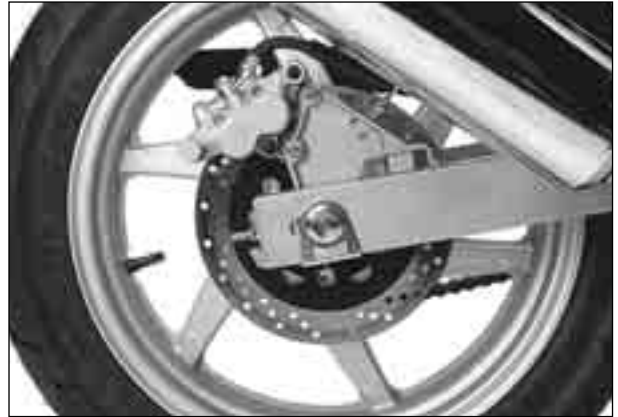

REAR SHOCK ABSORBER

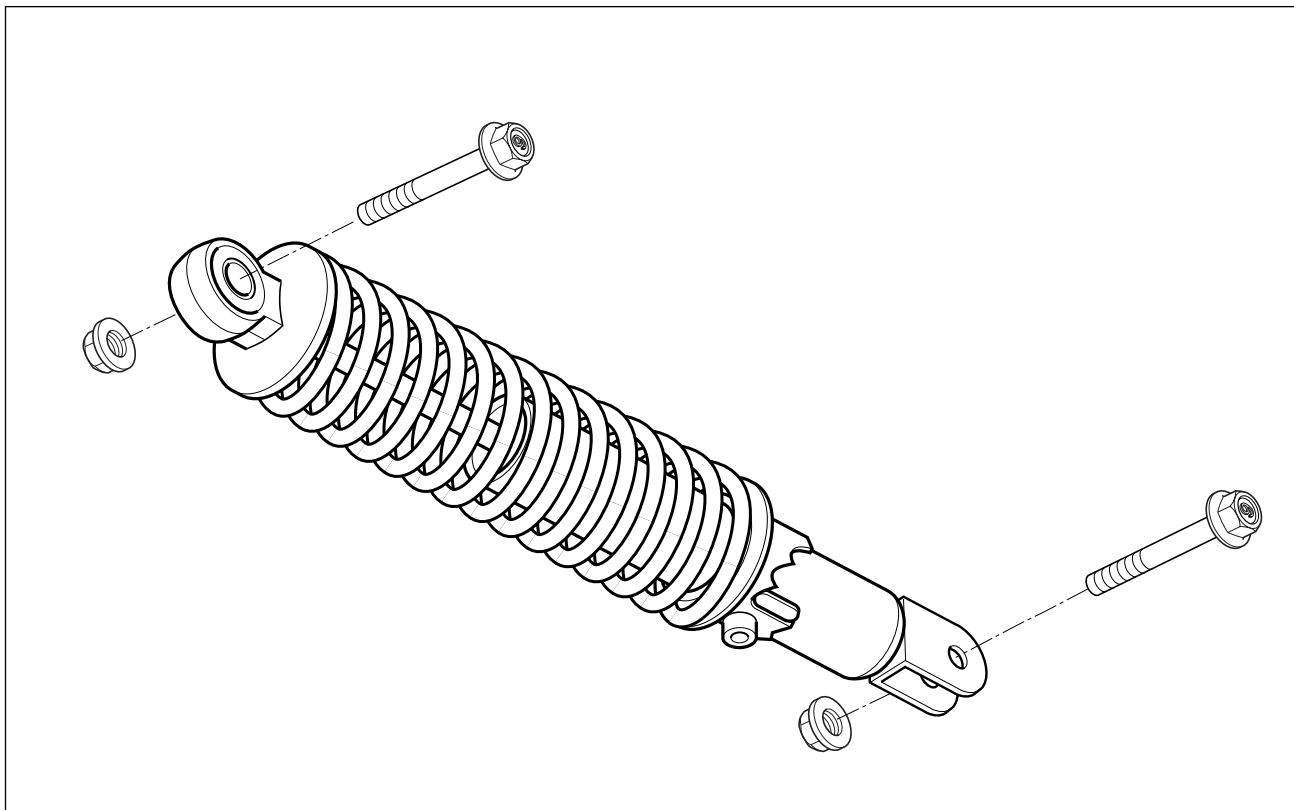

REMOVAL

- Remove the rear shock absorbers by removing their nuts.

INSPECTION

Inspect the rear shock absorber for damage and oil leakage. If any defects are found, replace the rear shock absorber with a new one.

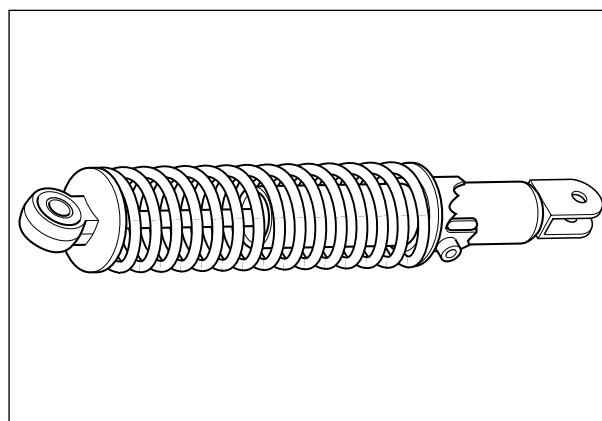

CAUTION

Do not attempt to disassemble the rear shock absorber. It is unserviceable.

REMountING

- Install the rear shock absorber and tighten the nuts to the specified torque.

-  Shock absorber mounting nut (upper)
 - : 40~60 N · m (4.0~6.0 kg · m)
- Shock absorber mounting nut (lower)
 - : 40~60 N · m (4.0~6.0 kg · m)

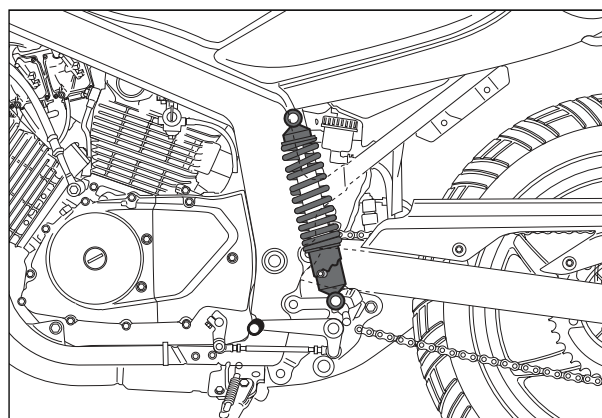

SWINGARM

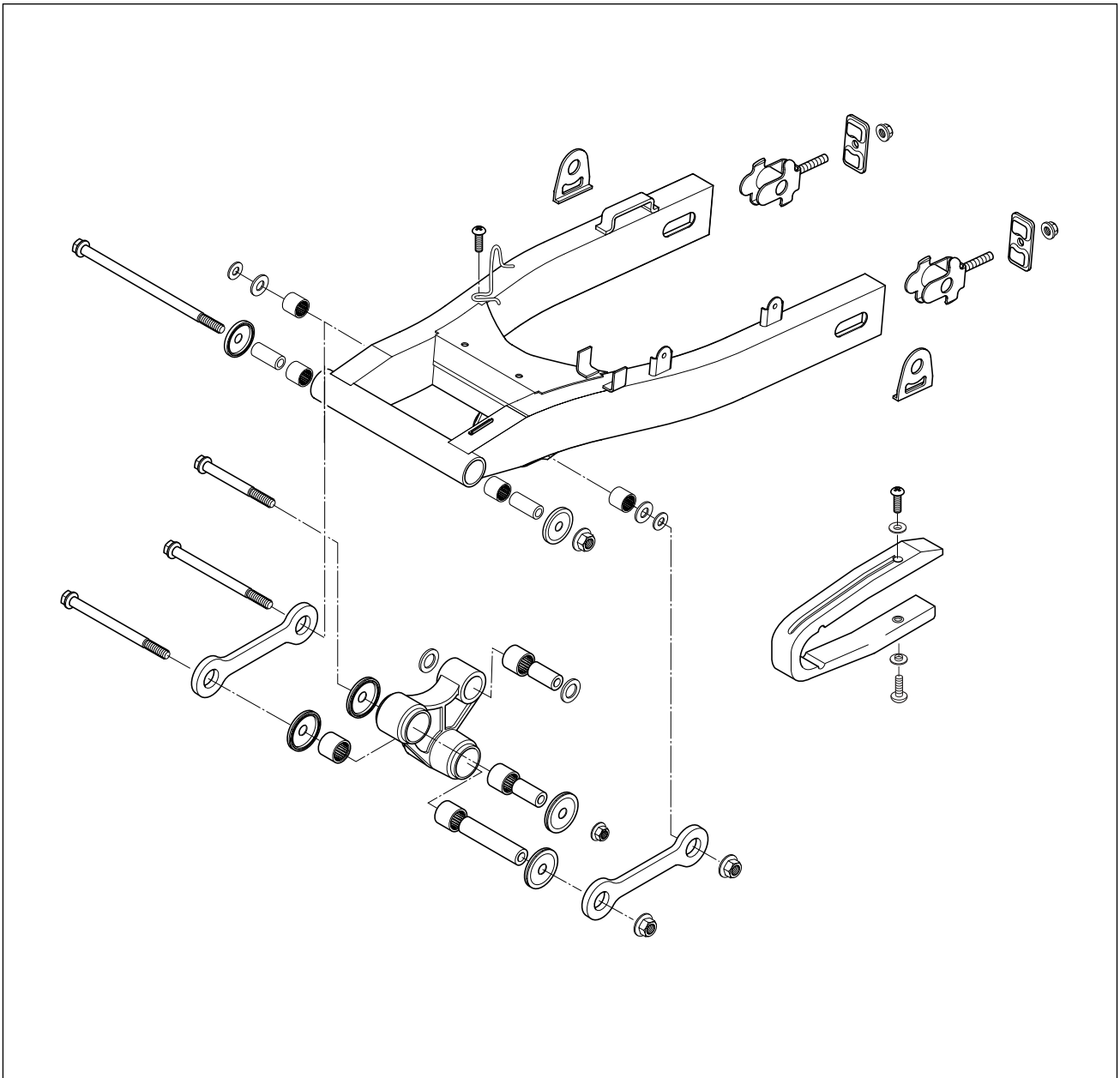

⊙ REMOVAL AND DISASSEMBLY

- Remove the rear wheel. (See page 6-30)
- Remove the rear shock absorber fitting nut and bolt. (See page 6-36)
- Remove the swing arm pivot nut.
- Draw out the pivot shaft and take off the swing arm.

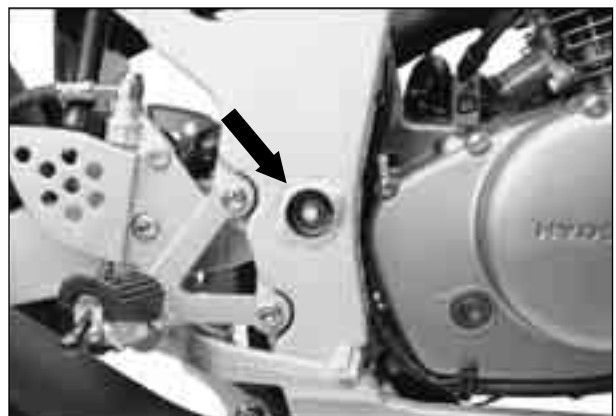

- Remove the chain case.
- Remove the two spacers.
- Remove the bearing by using the special tools.

 **Bearing remover (17 mm) : 09923-73210**
Rotor remover sliding shaft : 09930-30102

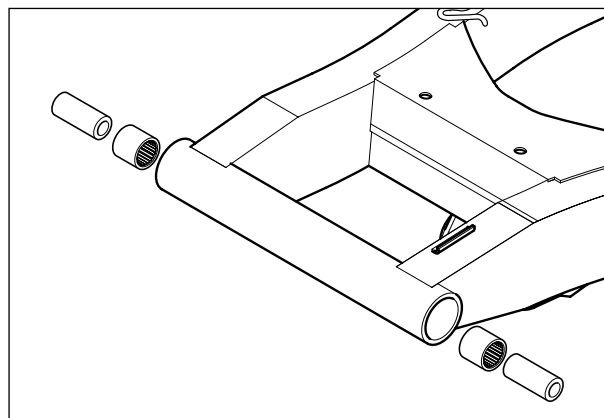

⊙ INSPECTION

■ SWINGARM

Inspect the swingarm for damage.

If any defects are found, replace the swingarm with a new one.

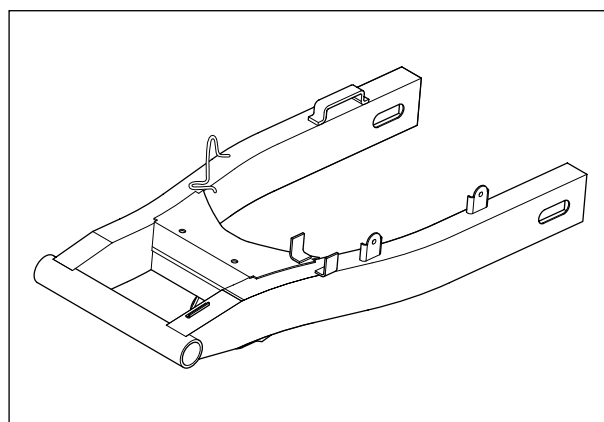

■ CHAIN BUFFER

Inspect the chain buffer for wear and damage. If any defects are found, replace the chain buffer with a new one.

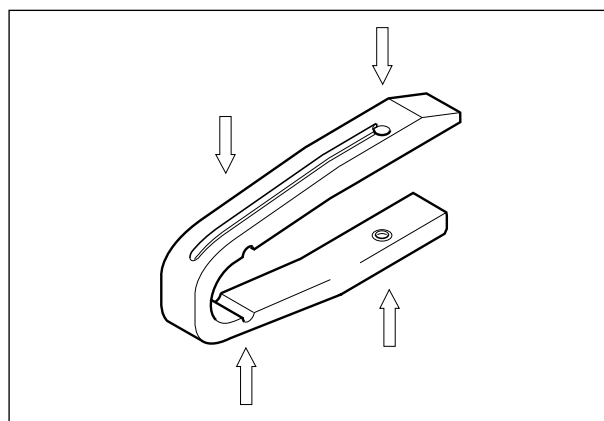

■ SWINGARM PIVOT SHAFT

Measure the pivot shaft runout using the dial gauge. If the pivot shaft exceeds the service limit, replace it with a new one.

 **Dial gauge : 09900-20606**
Magnetic stand : 09900-20701
V-block : 09900-21304

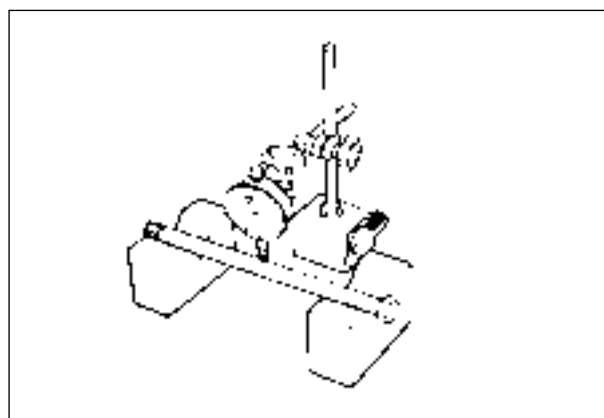

Swingarm pivot shaft runout	Service limit
	0.6 mm (0.024 in)

6-39 CHASSIS

⦿ REASSEMBLY

Reassemble the swingarm and rear shock absorber in the reverse order of disassembly.

Pay attention to the following points :

- Press the needle bearings into the swingarm pivot using the special tool.

 **Steering race installer : 09941-34513**

- Apply SUPER GREASE “A” to the needle bearing and spacers.

 **SUPER GREASE “A”**

- Install the swingarm and tighten the swingarm pivot nut to the specified torque.

 **Swingarm pivot nut**
: 45~70 N · m (4.5~7.0 kg · m)

- Install the rear wheel. (Refer to page 6-32)
- Install the rear shock absorber. (Refer to page 6-36)
- Adjust the following points :
Drive chain slack : Refer to page 2-13

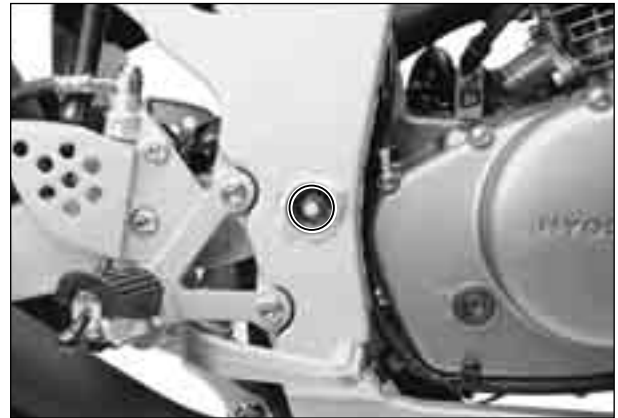
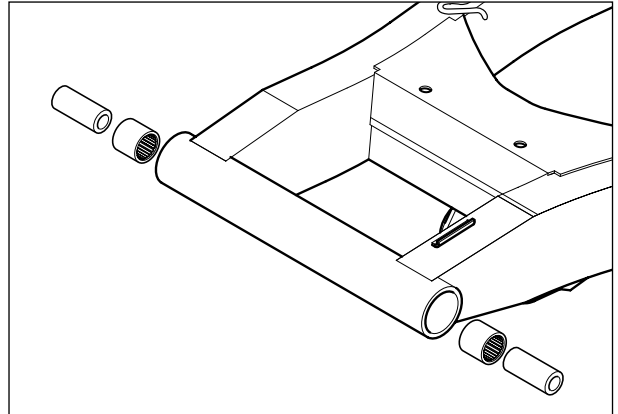

SERVICING INFORMATION

CONTENTS

TROUBLESHOOTING	7- 1
SPECIAL TOOLS	7- 8
TIGHTENING TORQUE	7-11
SERVICE DATA	7-13
WIRE AND CABLE ROUTING (『Comet 250 』)	7-23
WIRE AND CABLE ROUTING (『Comet 125 』)	7-27
WIRING DIAGRAM (『Comet 250 』)	7-31
WIRING DIAGRAM (『Comet 125 』)	7-32

TROUBLESHOOTING

ENGINE

Complaint	Symptom and possible causes	Remedy
<p>Engine will not start, or is hard to start.</p>	<p>Compression too low</p> <ol style="list-style-type: none"> 1. Valve clearance out of adjustment. 2. Worn valve guides or poor seating of valves. 3. Valves mistiming 4. Piston rings excessively worn. 5. Worn-down cylinder bore. 6. Poor seating of spark plug. 7. Starter motor cranks but too slowly. <p>Plug not sparking</p> <ol style="list-style-type: none"> 1. Fouled spark plug. 2. Wet spark plug. 3. Defective ignition coil. 4. Open or short circuit in high tension cord. <p>No fuel reaching the carburetor</p> <ol style="list-style-type: none"> 1. Clogged hole in the fuel tank cap. 2. Clogged or defective fuel cock. 3. Defective carburetor float valve. 4. Clogged fuel pipe. 	<p>Adjust. Repair or replace. Adjust. Replace. Replace or rebore. Retighten. Consult "electrical complaints"</p> <p>Clean or replace. Clean and dry. Replace. Replace..</p> <p>Clean. Clean or replace. Replace. Clean or replace.</p>
<p>Engine stalls easily.</p>	<ol style="list-style-type: none"> 1. Fouled spark plug. 2. Clogged fuel hose. 3. Clogged jets in carburetor. 4. Valve clearance out of adjustment. 	<p>Clean. Clean. Clean. Adjust.</p>
<p>Noisy engine.</p>	<p>Excessive valve chatter</p> <ol style="list-style-type: none"> 1. Valve clearance too large. 2. Weakened or broken valve springs. 3. Worn down camshaft. <p>Noise appears to come from piston</p> <ol style="list-style-type: none"> 1. Piston or cylinder worn down. 2. Weakened or broken valve springs. 3. Worn down piston pin or piston pin bore. 4. Piston rings or ring groove worn. <p>Noise seems to come from timing chain</p> <ol style="list-style-type: none"> 1. Stretched chain. 2. Worn sprockets. 3. Tension adjuster not working. <p>Noise seems to come from clutch</p> <ol style="list-style-type: none"> 1. Worn splines of countershaft or hub. 2. Worn teeth of clutch plates. 3. Distorted clutch plates, driven and drive. <p>Noise seems to come from crankshaft</p> <ol style="list-style-type: none"> 1. Worn or broken bearings. 2. Big-end bearings worn and broken. 3. Thrust clearance too large. 	<p>Adjust. Replace. Replace.</p> <p>Replace. Replace. Replace. Replace.</p> <p>Replace. Replace. Repair or replace.</p> <p>Replace. Replace. Replace.</p> <p>Replace. Replace. Replace.</p>

7-3 SERVICING INFORMATION

Complaint	Symptom and possible causes	Remedy
Engine lacks power.	<ol style="list-style-type: none"> 1. Loosen of valve clearance. 2. Weakened valve springs. 3. Valve timing out of adjustment. 4. Worn piston ring or cylinder. 5. Poor seating of valves. 6. Fouled spark plug. 7. Worn camshaft. 8. Spark plug gap incorrect. 9. Clogged jets in carburetor. 10. Float-chamber fuel level out of adjustment. 11. Clogged air cleaner element. 12. Too much enging oil. 13. Defective air intake pipe. 	Adjust. Replace. Adjust. Replace. Repair or replace. Clean or replace. Replace. Adjust or replace. Clean. Adjust. Clean. Drain out excess oil. Retighten or replace.
Engine overheats.	<ol style="list-style-type: none"> 1. Heavy carbon deposit on piston head. 2. Not enough oil in the engine. 3. Defective oil pump or clogged oil circuit. 4. Fuel level too low in float chamber. 5. Air leak from intake pipe. 6. Use of incorrect engine oil. 7. Defective oil cooler. 	Clean. Add oil. Repair or clean. Adjust. Retighten or replace. change. Clean or replace.

CARBURETOR

Complaint	Symptom and possible causes	Remedy
Trouble with starting.	<ol style="list-style-type: none"> 1. Starter jet is clogged. 2. Starter pipe is clogged. 3. Air leaking from a joint between starter body and carburetor. 4. Starter plunger is not operating properly. 	Clean. Clean. Check starter body and carburetor for tightness, adjust and replace gasket. Check and adjust.
Idling or low-speed trouble.	<ol style="list-style-type: none"> 1. Pilot jet, pilot air jet are clogged or loose. 2. Pilot outlet or bypass is clogged. 3. Starter plunger is not fully closed. 	Check and clean. Check and clean. Check and clean.
Medium or high speed trouble.	<ol style="list-style-type: none"> 1. Main jet or main air jet is clogged. 2. Needle jet is clogged. 3. Throttle valve is not operating properly. 4. Filter is clogged. 	Check and clean. Check and clean. Check throttle valve for operation. Check and clean.
Overflow and fuel level fluctuations.	<ol style="list-style-type: none"> 1. Needle valve is worn or damaged. 2. Spring in needle valve is broken. 3. Float is not working properly. 4. Foreign matter has adhered to needle valve. 5. Fuel level is too high or low. 	Replace. Replace. Check and adjust. Clean. Adjust float height.

ELECTRICAL

Complaint	Symptom and possible causes	Remedy
No sparking or poor sparking.	<ol style="list-style-type: none"> 1. Defective ignition coil. 2. Defective spark plug. 3. Defective CDI unit. 	Replace. Replace. Replace.
Spark plug soon become fouled with carbon.	<ol style="list-style-type: none"> 1. Mixture too rich. 2. Idling speed set too high. 3. Incorrect gasoline. 4. Dirty element in air cleaner. 5. Spark plug too cold. 	Adjust carburetor. Adjust carburetor. Change. Clean or replace. Replace by hot type plug.
Spark plug become fouled too soon.	<ol style="list-style-type: none"> 1. Worn piston rings. 2. Pistons or cylinder worn. 3. Excessive clearance of valve stems in valve guides. 4. Worn stem oil seal. 	Replace. Replace. Replace. Replace.
Spark plug electrodes overheat or burn.	<ol style="list-style-type: none"> 1. Spark plug too hot. 2. The engine overheats. 3. Spark plug loose. 4. Mixture too lean. 	Replace by cold type plug. Tune up. Retighten. Adjust carburetor.
Generator charge, but charging rate is below the specification.	<ol style="list-style-type: none"> 1. Lead wires tend to get shorted or open-circuited or loosely connected at terminals. 2. Grounded or open-circuited stator coils of generator. 3. Defective regulator/rectifier. 4. Not enough electrolyte in the battery. 5. Defective cell plates in the battery. 	Repair or retighten. Replace. Replace. Add distilled water between the level lines. Replace the battery.
Generator overcharges.	<ol style="list-style-type: none"> 1. Internal short-circuit in the battery. 2. Resistor element in the regulator/rectifier damaged or defective. 3. Regulator/rectifier poorly grounded. 	Replace the battery. Replace. Clean and tighten ground connection.
Unstable charging.	<ol style="list-style-type: none"> 1. Lead wire insulation frayed due to vibration resulting in intermittent shorting. 2. Generator internally shorted. 3. Defective regulator/rectifier. 	Repair or replace Replace. Replace.
Starter switch is not effective.	<ol style="list-style-type: none"> 1. Battery run down. 2. Defective switch contacts. 3. Brushes not seating properly on commutator in starter motor. 4. Defective starter relay. 	Recharge or replace. Replace. Repair or replace. Replace.

7-5 SERVICING INFORMATION

BATTERY

Complaint	Symptom and possible causes	Remedy
<p>“Sulfation” acidic white powdery substance or spots on surfaces of cell plates.</p>	<ol style="list-style-type: none"> 1. Not enough electrolyte. 2. Battery case is cracked. 3. Battery has been left in a run-down condition for a long time. 4. Contaminated electrolyte. (Foreign matter has enters the battery and become mixed with the electrolyte.) 	<p>Add distilled water, if the battery has not been damaged and “sulfation” has not advanced too far, and recharge. Replace the battery. Replace the battery or recharge.</p> <p>If “sulfation” has not advanced far, try to restore the battery by replacing the electrolyte, recharging it fully with the battery detached from the motorcycle and then adjusting electrolyte specific gravity.</p>
<p>Battery runs down quickly.</p>	<ol style="list-style-type: none"> 1. The charging method is not correct. 2. Cell plates have lost much of their active material as a result of over-charging. 3. A short-circuit condition exists within the battery due to excessive accumulation of sediments caused by the high electrolyte specific gravity. 4. Electrolyte specific gravity is too low. 5. Contaminated electrolyte. 6. Battery is too old. 	<p>Check the generator, regulator /rectifier and circuit connections, and make necessary adjustments to obtain specified charging operation. Replace the battery, and correct the charging system. Replace the battery.</p> <p>Recharge the battery fully and adjust electrolyte specific gravity. Replace the electrolyte, recharge the battery and then adjust specific gravity. Replace the battery.</p>
<p>Reversed battery polarity.</p>	<p>The battery has been connected the wrong way round in the system, so that it is being charged in the reverse direction.</p>	<p>Replace the battery and be sure to connect the battery properly.</p>
<p>Battery “sulfation”</p>	<ol style="list-style-type: none"> 1. Charging rate too low or too high. (When not in use, batteries should be recharged at least once a month to avoid sulfation.) 2. Battery electrolyte excessive or insufficient, or its specific gravity too high or too low. 3. The battery left unused for too long in cold climate. 	<p>Replace the battery.</p> <p>Keep the electrolyte up to the prescribed level, or adjust the specific gravity by consulting the battery maker’ s directions.</p> <p>Replace the battery, if badly sulfated.</p>
<p>Battery discharges too rapidly.</p>	<ol style="list-style-type: none"> 1. Dirty container top and sides. 2. Impurities in the electrolyte or electrolyte specific gravity is too high. 	<p>Clean. Change the electrolyte by consulting the battery maker’ s directions.</p>

CHASSIS









Complaint	Symptom and possible causes	Remedy
Steering feels too heavy or stiff.	<ol style="list-style-type: none"> 1. Steering stem nut overtightened. 2. Worn bearing or race in steering stem. 3. Distorted steering stem. 4. Not enough pressure in tires. 	Adjust. Replace. Replace. Adjust.
Steering oscillation.	<ol style="list-style-type: none"> 1. Loss of balance between right and left front suspensions. 2. Distorted front fork. 3. Distorted front axle or crooked tire. 	Replace. Repair or replace. Replace.
Wobbling front wheel.	<ol style="list-style-type: none"> 1. Distorted wheel rim. 2. Worn-down wheel bearings. 3. Defective or incorrect tire. 4. Loosen nut on axle. 	Replace. Replace. Replace. Retighten.
Front suspension too soft.	<ol style="list-style-type: none"> 1. Weakened springs. 2. Not enough fork oil. 	Replace. Refill.
Front suspension too stiff.	<ol style="list-style-type: none"> 1. Fork oil too viscous. 2. Too much fork oil. 	Replace. Drain excess oil.
Noisy front suspension.	<ol style="list-style-type: none"> 1. Not enough fork oil. 2. Loosen nuts on suspension. 	Refill. Retighten.
Wobbling rear wheel.	<ol style="list-style-type: none"> 1. Distorted wheel rim. 2. Worn-down rear wheel bearing. 3. Defective or incorrect tire. 4. Loose nut on axle. 5. Worn swing arm bushing or bearing. 6. Loosen nut on the rear shock. 	Replace. Replace. Replace. Retighten. Replace. Retighten.
Rear suspension too soft.	<ol style="list-style-type: none"> 1. Weakened springs. 2. Rear suspension adjuster improperly set. 	Replace. Adjust.
Rear suspension too stiff.	<ol style="list-style-type: none"> 1. Rear suspension adjuster improperly set. 2. Worn swing arm bushing or bearing. 	Adjust. Replace.
Noisy rear suspension.	<ol style="list-style-type: none"> 1. Loosen nuts on suspension. 2. Worn swing arm bushing or bearing. 	Retighten. Replace.









7-7 SERVICING INFORMATION

BRAKES

Complaint	Symptom and possible causes	Remedy
Poor braking (FRONT and REAR)	<ol style="list-style-type: none">1. Not enough brake fluid in the reservoir.2. Air trapped in brake fluid circuit.3. Pads worn down.4. Too much play on brake lever or pedal.	Refill to level mark. Bleed air out. Replace. Adjust.
Insufficient brake power.	<ol style="list-style-type: none">1. Leakage of brake fluid from hydraulic system.2. Worn pads.3. Oil adhesion of engaging surface of pads.4. Worn disk.5. Air in hydraulic system.	Repair or replace. Replace. Clean disk and pads. Replace. Bleed air.
Brake squeaking.	<ol style="list-style-type: none">1. Carbon adhesion on pad surface.2. Tilted pad.3. Damaged wheel bearing.4. Loosen front-wheel axle or rear-wheel axle.5. Worn pads.6. Foreign material in brake fluid.7. Clogged return port of master cylinder.	Repair surface with sandpaper. Modify pad fitting. Replace. Tighten to specified torque. Replace. Replace brake fluid. Disassemble and clean master cylinder.
Excessive brake lever stroke.	<ol style="list-style-type: none">1. Air in hydraulic system.2. Insufficient brake fluid.3. Improper quality of brake fluid.	Bleed air. Replenish fluid to specified level ; bleed air. Replace with correct fluid.
Leakage of brake fluid.	<ol style="list-style-type: none">1. Insufficient tightening of connection joints.2. Cracked hose.3. Worn piston and/or cup.	Tighten to specified torque. Replace. Replace piston and/or cup.









SPECIAL TOOLS

Special tools	Part Number · Part Name · Description
	09900-20101 Vernier Caliper Used to conveniently measure various dimensions.
	09900-20201 Micrometer(0~25mm) Used for precise measurement (00-25mm measure ranges).
	09900-20202 Micrometer(25~50mm) Used for precise measurement (25-50mm measure ranges).
	09900-20203 Micrometer(50~75mm) Used for precise measurement (50-75mm measure ranges).
	09900-20508 Cylinder gauge set Measure inside diameter of cylinder.
	09900-20605 Dial calipers Measure width of conrod big-end.
	09900-20606 Dial gauge Measure oscillation of wheel with using magnetic stand.
	09900-20701 Magnetic stand With using dial gauge.
	09900-20806 Thickness gauge Measure clearance of piston ring.

Special tools	Part Number · Part Name · Description
	09900-21109 Torque wrench Measure torque of tightening.
	09900-21304 V-block With using magnetic stand.
	09900-22301 Plastigauge Measure clearance of crankshaft thrust.
	09900-22401 Small bore gauge Measure inside diameter of conrod small-end.
	09900-25002 Pocket tester Measure voltage, electric current, resistance.
	09900-26006 Engine tachometer Measure rotational frequency of engine.
	09900-28107 Electro tester Inspect ignition coil.
	09900-28500 Battery charger Used to charge the discharged battery.
	09910-20115 Conrod holder Used to lock the crankshaft.

7-9 SERVICING INFORMATION

Special tools	Part Number · Part Name · Description
	09910-32812 Crankshaft installer Used to install the crankshaft in the crankcase.
	09910-34510 Piston pin puller Use to remove the piston pin.
	09913-10760 Fuel level gauge Measure height of carburetor.
	09913-50121 Oil seal remover Used to remove the oil seal.
	09913-70122 Bearing installer Used to drive bearing in.
	09913-75520 Bearing installer Used to drive bearing in.
	09913-75820 Bearing installer Used to drive bearing in.
	09913-75830 Bearing installer Used to install rear axle shaft oil seal.
	09913-76010 Bearing installer Used to drive crankshaft bearing in.

Special tools	Part Number · Part Name · Description
	09913-80112 Bearing installer Used to drive bearing in.
	09915-63310 Compression gauge adapter Used with compression gauge.
	09915-64510 Compression gauge Measure cylinder compression.
	09915-74510 Oil pressure gauge Measure oil pressure of 4-stroke engine.
	09916-14510 Valve spring compressor Used to remove and remounting valve stem.
	09916H35C00 『Comet 250』 Valve spring compressor attachment Used with valve spring compressor.
	09916HG5100 『Comet 125』 Valve spring compressor attachment Used with valve spring compressor.
	09920-13120 Crankcase separator Separate to crankcase.
	09920-53710 Clutch sleeve hub holder Used to install or remove clutch sleeve hub nut.

Special tools	Part Number · Part Name · Description
	09921-20200 Bearing remover(10mm)
	Used to remove oil seal or bearing.
	09921-20210 Bearing remover(12mm)
	Used to remove oil seal or bearing.
	09923-73210 Bearing remover(17mm)
	Used to remove bearing with the rotor remove sliding shaft.
	09923-74510 Bearing remover(20~35mm)
	Used to remove bearing with the rotor remove sliding shaft.
	09924-84521 Bearing installer
	Used to drive small bearing in.
	09930-30102 Rotor remove sliding shaft
	Used to with bearing remover or rotor remover.
	09930-30162 『Comet 125』 Rotor remover
	Attached to the top of sliding shaft when removing rotor.
	09930-30164 『Comet 250』 Rotor remover
	Attached to the top of sliding shaft when removing rotor.
	09930-40113 Rotor holder
	Widely used to lock rotary parts such as a flywheel magneto.

Special tools	Part Number · Part Name · Description
	09930-44510 Rotor holder
	Widely used to lock rotary parts such as a flywheel magneto.
	09940-10122 Clamp wrench
	A hook wrench to adjust the steering head of motorcycle.
	09940-34520 T-handle
	Remove and remounting front fork oil cylinder.
	09940-34561 Front fork assembling tool attachment "D"
	Used with T-handle.
	09940-50113 Front fork oil seal installer
	Install front fork oil seal.
	09941-34513 Steering race installer
	Used to install steering outer race.
	09941-50111 Wheel bearing remover
	Used to remove wheel bearing.
	09943-74111 Front fork oil level gauge
	Used to drain the fork oil to the specified level.

TIGHTENING TORQUE

ENGINE

ITEM	N · m	kg · m
Magneto rotor nut	50 ~ 60	5.0 ~ 6.0
Magneto cover bolt	8 ~ 12	0.8 ~ 1.2
Muffler mounting bolt	20 ~ 30	2.0 ~ 3.0
Exhaust pipe nut	18 ~ 28	1.8 ~ 2.8
Starter clutch bolt	15 ~ 20	1.5 ~ 2.0
Cylinder head bolt	7 ~ 11	0.7 ~ 1.1
Cylinder head cover bolt	12 ~ 16	1.2 ~ 1.6
Cylinder head stud bolt	21 ~ 25	2.1 ~ 2.5
Cylinder head base nut (『 <i>Comet-250</i> 』)	7 ~ 11	0.7 ~ 1.1
Cylinder head base nut (『 <i>Comet-125</i> 』)	15 ~ 20	1.5 ~ 2.0
Engine sprocket nut	80 ~ 100	8.0 ~ 10.0
Engine oil drain plug	18 ~ 20	1.8 ~ 2.0
Engine mounting bolt	40 ~ 60	4.0 ~ 6.0
Cam chain sprocket bolt	10 ~ 13	1.0 ~ 1.3
Cam chain tensioner bolt	6 ~ 8	0.6 ~ 0.8
Cam chain tension adjuster bolt	8 ~ 12	0.8 ~ 1.2
Camshaft sprocket bolt	10 ~ 12	1.0 ~ 1.2
Crankcase bolt	8 ~ 12	0.8 ~ 1.2
Clutch sleeve hub nut	30 ~ 50	3.0 ~ 5.0
Primary drive gear nut	40 ~ 60	4.0 ~ 6.0
Camshaft housing bolt	8 ~ 12	0.8 ~ 1.2
Oil cooler union bolt (M10)	20 ~ 25	2.0 ~ 2.5
Oil cooler union bolt (M12)	20 ~ 25	2.0 ~ 2.5
Spark plug	20 ~ 25	2.0 ~ 2.5
Neutral cam stopper plug	20 ~ 25	2.0 ~ 2.5

CHASSIS

ITEM	N · m	kg · m
Rear shock absorber mounting nut (Upper)	40 ~ 60	4.0 ~ 6.0
Rear shock absorber mounting nut (Lower)	40 ~ 60	4.0 ~ 6.0
Rear sprocket nut	20 ~ 30	2.0 ~ 3.0
Rear axle nut	90 ~ 140	9.0 ~ 14.0
Swing arm pivot nut	45 ~ 70	4.5 ~ 7.0
Steering stem nut	80 ~ 100	8.0 ~ 10.0
Steering stem head nut	80 ~ 100	8.0 ~ 10.0
Front and Rear brake disc bolt	18 ~ 28	1.8 ~ 2.8
Front brake master cylinder mounting bolt	5 ~ 8	0.5 ~ 0.8
Rear brake master cylinder mounting bolt	18 ~ 28	1.8 ~ 2.8
Front and Rear brake caliper air bleeder valve	6 ~ 9	0.6 ~ 0.9
Front and Rear brake caliper mounting bolt	18 ~ 28	1.8 ~ 2.8
Front and Rear brake hose union bolt	20 ~ 25	2.0 ~ 2.5
Front axle bolt	50 ~ 80	5.0 ~ 8.0
Front axle pinch bolt	15 ~ 25	1.5 ~ 2.5
Front fork damper rod bolt	30 ~ 40	3.0 ~ 4.0
Front fork upper clamp bolt	22 ~ 35	2.2 ~ 3.5
Front fork upper bolt	22 ~ 30	2.2 ~ 3.0
Front fork lower clamp bolt	22 ~ 35	2.2 ~ 3.5
Front footrest bolt	22 ~ 35	2.2 ~ 3.5
Handlebar clamp bolt	18 ~ 28	1.8 ~ 2.8

7-13 SERVICING INFORMATION

SERVICE DATA

VALVE + GUIDE (『 Comet 250 』)

Unit : mm (in)

ITEM	STANDARD		LIMIT
Valve diam.	IN.	22.0 (0.87)	—
	EX.	19.0 (0.75)	—
Valve clearance (When cold)	IN.	0.1 ~ 0.2 (0.004 ~ 0.008)	—
	EX.	0.2 ~ 0.3 (0.008 ~ 0.012)	—
Valve guide to valve stem clearance	IN.	0.010 ~ 0.037 (0.0004 ~ 0.0015)	—
	EX.	0.030 ~ 0.057 (0.0012 ~ 0.0022)	—
Valve stem deflection	IN. & EX.	—	0.35 (0.014)
Valve guide I.D.	IN. & EX.	4.500 ~ 4.512 (0.1771 ~ 0.1776)	—
Valve stem O.D.	IN.	4.475 ~ 4.490 (0.1762 ~ 0.1768)	—
	EX.	4.455 ~ 4.470 (0.1754 ~ 0.1760)	—
Valve stem runout	IN. & EX.	—	0.05 (0.002)
Valve head thickness	IN. & EX.	—	0.50 (0.02)
Valve seat width	0.9 ~ 1.1 (0.035 ~ 0.043)		—
Valve seat angle	IN. & EX.	45°	
Valve head radial runout	IN. & EX.	—	0.03 (0.0012)
Valve spring free length	IN.	—	37.80 (1.488)
	EX.	—	37.80 (1.488)
Valve spring tension	IN.	12.1 ~ 13.9kgf (26.7 ~ 30.6 lbs) at length 33.7mm (1.33 in)	—
	EX.	12.1 ~ 13.9kgf (26.7 ~ 30.6 lbs) at length 33.7mm (1.33 in)	—

VALVE + GUIDE (『 Comet 125 』)

Unit : mm (in)

ITEM	STANDARD		LIMIT
Valve diam.	IN.	18.0 (0.71)	—
	EX.	14.5 (0.57)	—
Valve clearance (When cold)	IN.	0.1 ~ 0.2 (0.004 ~ 0.008)	—
	EX.	0.2 ~ 0.3 (0.008 ~ 0.012)	—
Valve guide to valve stem clearance	IN.	0.010 ~ 0.037 (0.0004 ~ 0.0015)	—
	EX.	0.030 ~ 0.057 (0.0012 ~ 0.0022)	—
Valve stem deflection	IN. & EX.	—	0.35 (0.014)
Valve guide I.D.	IN. & EX.	4.000 ~ 4.012 (0.1575 ~ 0.1580)	—
Valve stem O.D.	IN.	3.975 ~ 3.990 (0.1565 ~ 0.1571)	—
	EX.	3.955 ~ 3.970 (0.1557 ~ 0.1563)	—
Valve stem runout	IN. & EX.	—	0.05 (0.002)
Valve head thickness	IN. & EX.	—	0.50 (0.02)
Valve seat width	0.9 ~ 1.1 (0.035 ~ 0.043)		—
Valve seat angle	IN. & EX.	45°	
Valve head radial runout	IN. & EX.	—	0.03 (0.0012)
Valve spring free length	IN.	—	37.64 (1.482)
	EX.	—	37.64 (1.482)
Valve spring tension	IN.	30 kgf (66.1 lbs) at length 27.95mm (1.10 in)	—
	EX.	30 kgf (66.1 lbs) at length 27.95mm (1.10 in)	—

CAMSHAFT + CYLINDER HEAD

Unit : mm (in)

ITEM	STANDARD		LIMIT
Cam height	IN.	34.470 ~ 34.510 (1.357 ~ 1.358)	34.170 (1.345)
	EX.	34.420 ~ 34.460 (1.355 ~ 1.356)	34.120 (1.343)
Camshaft journal holder I.D.	IN. & EX.	35.000 ~ 35.018 (1.378 ~ 1.379)	—
Cylinder and cylinder head distortion	—		0.05 (0.002)
Cylinder head cover distortion	—		0.05 (0.002)
Cam chain pin (Arrow “3”)	16th pin		—

7-15 SERVICING INFORMATION

CYLINDER + PISTON + PISTON RING (『 Comet 250 』)

Unit : mm (in)

ITEM	STANDARD		LIMIT
Compression pressure	14~16 kg/cm ² (at 500 rpm)		12 kg/cm ²
Piston to cylinder clearance	0.050 ~ 0.060 (0.0020 ~ 0.0024)		0.120 (0.0047)
Cylinder bore	57.000 ~ 57.015 (2.2441 ~ 2.2447)		57.080 (2.2473)
Piston diam.	56.945 ~ 56.960 (2.2419 ~ 2.2425) (Measure at 15mm (0.6 in) from the skirt end)		56.880 (2.2394)
Cylinder or cylinder head distortion	—		0.05 (0.002)
Piston ring free end gap	1st	7.2 (0.284)	5.7 (0.224)
	2nd	5.8 (0.228)	4.6 (0.181)
Piston ring end gap (Assembly condition)	1st	0.20 ~ 0.32 (0.008 ~ 0.013)	0.5 (0.020)
	2nd	0.20 ~ 0.32 (0.008 ~ 0.013)	0.5 (0.020)
Piston ring to groove clearance	1st	—	0.180 (0.007)
	2nd	—	0.150 (0.006)
Piston ring groove width	1st	1.01 ~ 1.03 (0.040 ~ 0.041)	—
	2nd	1.01 ~ 1.03 (0.040 ~ 0.041)	—
	Oil	2.01 ~ 2.03 (0.079 ~ 0.080)	—
Piston ring thickness	1st	0.970 ~ 0.990 (0.0382 ~ 0.0390)	—
	2nd	0.970 ~ 0.990 (0.0382 ~ 0.0390)	—
Piston pin hole bore	15.002 ~ 15.008 (0.5906 ~ 0.5909)		15.030 (0.5917)
Piston pin O.D.	14.994 ~ 15.000 (0.5903 ~ 0.5905)		14.980 (0.5898)

CYLINDER + PISTON + PISTON RING (『 Comet-125 』)

Unit : mm (in)

ITEM	STANDARD		LIMIT
Compression pressure	11~13 kg/cm ² (at 500 rpm)		10 kg/cm ²
Piston to cylinder clearance	0.03 ~ 0.04 (0.0012 ~ 0.0016)		0.1 (0.0040)
Cylinder bore	44.000 ~ 44.015 (1.7323 ~ 1.7329)		44.080 (1.7354)
Piston diam.	43.965 ~ 43.980 (1.7309 ~ 1.7315) (Measure at 11mm (0.4 in) from the skirt end)		43.890 (1.7280)
Cylinder or cylinder head distortion	—		0.05 (0.002)
Piston ring free end gap	1st	5.0 (0.197)	4.0 (0.158)
	2nd	6.0 (0.236)	4.8 (0.189)
Piston ring end gap (Assembly condition)	1st	0.10 ~ 0.25 (0.004 ~ 0.010)	0.5 (0.020)
	2nd	0.25 ~ 0.40 (0.010 ~ 0.016)	0.5 (0.020)
Piston ring to groove clearance	1st	—	0.180 (0.007)
	2nd	—	0.150 (0.006)
Piston ring groove width	1st	1.01 ~ 1.03 (0.040 ~ 0.041)	—
	2nd	1.01 ~ 1.03 (0.040 ~ 0.041)	—
	Oil	2.01 ~ 2.03 (0.079 ~ 0.080)	—
Piston ring thickness	1st	0.970 ~ 0.990 (0.0382 ~ 0.0389)	—
	2nd	0.970 ~ 0.990 (0.0382 ~ 0.0389)	—
Piston pin hole bore	8.9 ~ 9.1 (0.350 ~ 0.358)		13.030 (0.513)
Piston pin O.D.	—		13.980 (0.550)

CONROD + CRANKSHAFT (『 Comet-250 』)

Unit : mm (in)

ITEM	STANDARD		LIMIT
Conrod small end I.D.	15.006 ~ 15.014 (0.5908 ~ 0.5911)		15.040 (0.5921)
Conrod deflection	—		3.0 (0.12)
Conrod big end side clearance	0.40 ~ 0.85 (0.016 ~ 0.034)		1.0 (0.040)
Conrod big end width	15.95 ~ 16.00 (0.628 ~ 0.630)		—
Crank web to web width	72 ± 0.1 (2.84 ± 0.004)		—
Crankshaft runout	—		0.05 (0.002)

CONROD + CRANKSHAFT (『 Comet-125 』)

Unit : mm (in)

ITEM	STANDARD		LIMIT
Conrod small end I.D.	13.006 ~ 13.014 (0.5121 ~ 0.5124)		13.040 (0.5134)
Conrod deflection	—		3.0 (0.12)
Conrod big end side clearance	0.15 ~ 0.40 (0.006 ~ 0.016)		1.0 (0.040)
Conrod big end width	15.95 ~ 16.00 (0.628 ~ 0.630)		—
Crank web to web width	72 ± 0.1 (2.84 ± 0.004)		—
Crankshaft runout	—		0.05 (0.002)

7-17 SERVICING INFORMATION

OIL PUMP (『 *Comet-250* 』)

ITEM	STANDARD	NOTE
Oil pressure	2.0 ± 0.5 kg/cm ² (at 65 °C, 3,000 rpm)	—
Oil pump reduction ratio	58/19 × 14/20 = 2.137	—

OIL PUMP (『 *Comet-125* 』)

ITEM	STANDARD	NOTE
Oil pressure	0.9 ~ 1.1 kg/cm ² (at 65 °C, 3,000 rpm)	—
Oil pump reduction ratio	70/20 × 14/20 = 2.45	—

CLUTCH

Unit : mm (in)

ITEM	STANDARD	LIMIT
Clutch cable play	4 (0.16)	—
Drive plate thickness	2.9 ~ 3.1 (0.114 ~ 0.122)	2.6 (0.102)
Drive plate claw width	11.8 ~ 12.0 (0.465 ~ 0.472)	11.0 (0.433)
Driven plate distortion	—	0.1 (0.004)
Clutch spring free length (『 <i>Comet-250</i> 』)	38.2 (1.50)	36.2 (1.43)
Clutch spring free length (『 <i>Comet-125</i> 』)	—	29.5 (1.16)

TRANSMISSION + DRIVE CHAIN (『 Comet 250 』)

Unit : mm (in)

ITEM	STANDARD		LIMIT
Primary reduction ratio	3.053 (58/19)		—
Secondary reduction ratio	3.286 (46/14)		—
Gear ratio	1st	2.462 (32/13)	—
	2nd	1.556 (28/18)	—
	3rd	1.190 (25/21)	—
	4th	0.957 (22/23)	—
	5th	0.840 (21/25)	—
Shift fork to groove clearance	0.10 ~ 0.30 (0.004 ~ 0.012)		0.5 (0.020)
Shift fork groove width	NO.1 & NO.2	5.0 ~ 5.1 (0.197 ~ 0.201)	—
	NO.3	5.0 ~ 5.1 (0.197 ~ 0.201)	—
Shift fork thickness	NO.1 & NO.2	4.8 ~ 4.9 (0.189 ~ 0.193)	—
	NO.3	4.8 ~ 4.9 (0.189 ~ 0.193)	—
Drive chain	Type	520HO	—
	Links	112 LINKS	—
	20-pitch length	317.5 (12.50)	319.4 (12.58)
Drive chain slack	20~30 (0.79 ~ 1.18)		—

TRANSMISSION + DRIVE CHAIN (『 Comet 125 』)

Unit : mm (in)

ITEM	STANDARD		LIMIT
Primary reduction ratio	3.000 (70/20)		—
Secondary reduction ratio	3.714 (52/14)		—
Gear ratio	1st	2.750 (33/12)	—
	2nd	1.786 (25/14)	—
	3rd	1.350 (27/20)	—
	4th	1.091 (24/22)	—
	5th	0.913 (21/23)	—
Shift fork to groove clearance	0.10 ~ 0.30 (0.004 ~ 0.012)		0.5 (0.020)
Shift fork groove width	NO.1 & NO.2	5.0 ~ 5.1 (0.197 ~ 0.201)	—
	NO.3	5.5 ~ 5.6 (0.217 ~ 0.221)	—
Shift fork thickness	NO.1 & NO.2	4.8 ~ 4.9 (0.189 ~ 0.193)	—
	NO.3	5.3 ~ 5.4 (0.209 ~ 0.213)	—
Drive chain	Type	428SO	—
	Links	136 LINKS	—
	20-pitch length	254.0 (10.00)	256.5 (10.10)
Drive chain slack	20~30 (0.79 ~ 1.18)		—

7-19 SERVICING INFORMATION

CARBURETOR(^Γ *Comet-250* _Γ)

Unit : mm (in)

ITEM	SPECIFICATION							
Carburetor type	MIKUNI BDS26 TYPE(DOUBLE)							
Bore size	φ 26							
Idle r.p.m.	1,450~1,550 r.p.m.							
Float height	17 (0.67)							
Throttle cable play	0.5~1.0 (0.02 ~ 0.04)							
	FRONT				REAR			
Main jet (M.J.)	92.5				95			
Main air jet (M.A.J.)	90				90			
Jet needle (J.N.)	2ND				2ND			
Needle jet (N.J.)	O-3				O-4			
Pilot jet (P.J.)	20				20			
Throttle valve (TH.V.)	130				130			
By-pass (B.P.)	#1 0.9	#2 0.9	#3 0.8	#4 0.8	#1 0.9	#2 0.9	#3 0.8	#4 0.8
Valve seat (V.S.)	1.2				1.2			
Starter jet (G.S.)	22.5				22.5			
Pilot outlet (P.O.)	0.75				0.75			
PV. Stroke (P.V.)	STD				STD			

CARBURETOR(^Γ *Comet-125* _Γ)

Unit : mm (in)

ITEM	SPECIFICATION							
Carburetor type	MIKUNI BDS26 TYPE(DOUBLE)							
Bore size	φ 26							
Idle r.p.m.	1,450~1,550 r.p.m.							
Float height	17 (0.67)							
Throttle cable play	0.5~1.0 (0.02 ~ 0.04)							
	FRONT				REAR			
Main jet (M.J.)	87.5				90			
Main air jet (M.A.J.)	50				50			
Jet needle (J.N.)	2ND				2ND			
Needle jet (N.J.)	O-5				O-4			
Pilot jet (P.J.)	15				15			
Throttle valve (TH.V.)	130				130			
By-pass (B.P.)	#1 0.9	#2 0.9	#3 0.8	#4 0.8	#1 0.9	#2 0.9	#3 0.8	#4 0.8
Valve seat (V.S.)	1.2				1.2			
Starter jet (G.S.)	20				20			
Pilot outlet (P.O.)	0.75				0.75			
PV. Stroke (P.V.)	STD				STD			

ELECTRICAL

Unit : mm (in)

ITEM	STANDARD		NOTE
Ignition timing	15°/2,000rpm ~ 30°/6,000rpm		
Spark plug	Type	CR8E	
	Gap	0.7~0.8 (0.028 ~ 0.032)	
	Hot type	CR7E	
	Standard type	CR8E	
	Cold type	CR9E	
Spark performance	Over 8mm (0.32)		
Ignition coil resistance	Primary	0.19 ~ 0.24 Ω	
	Secondary	5.4 ~ 6.6 kΩ	
Magneto coil resistance	Pick-up coil	90 ~ 110 Ω	G-L
	Charging coil	0.6 ~ 0.9 Ω	Y-Y
Magneto no-load voltage	67 ~ 99V/5,000 rpm		
Battery standard charging voltage	14 ~ 15V/5,000 rpm		
Battery	Type	STX14A-BS	
	Capacity	12V 12Ah	
Fuse size	15A		

WATTAGE

Unit : W

ITEM	SPECIFICATION	
Head lamp (『 Comet-250 』)	HI	60W
	LO	55W
Head lamp (『 Comet-125 』)	HI	35W
	LO	35W
License lamp	5W	
Brake/Tail lamp	21/5W	
Turn signal lamp	10W	
Speedometer lamp	1.7W × 3	
Neutral indicator lamp	1.7W	
Turn signal indicator lamp (Right & left)	1.7W × 2	
High beam indicator lamp	1.7W	



CAUTION

Do not use except the specified bulb (Wattage).

7-21 SERVICING INFORMATION

SUSPENSION (『 *Comet-250* 』)

Unit : mm (in)

ITEM	STANDARD	LIMIT
Front fork stroke	120 (4.27)	—
Front fork spring free length	433.3 (17.1)	—
Front fork oil type	TELLUS #22	—
Front fork oil level	146 (5.8)	—
Front fork oil capacity (each leg)	400 ± 2.5cc	—
Rear wheel travel	110 (4.33)	—
Swingarm pivot shaft runout	—	0.6 (0.024)
Rear shock absorber pre-load position	2 / 5 position	—
Rear shock absorber spring length	179.2 (7.07)	175 (6.89)

SUSPENSION (『 *Comet-125* 』)

Unit : mm (in)

ITEM	STANDARD	LIMIT
Front fork stroke	120 (4.72)	—
Front fork spring free length	361 (14.2)	354 (13.9)
Front fork oil type	TELLUS #22	—
Front fork oil level	155 (6.1)	—
Front fork oil capacity (each leg)	262cc	—
Rear wheel travel	110 (4.33)	—
Swingarm pivot shaft runout	—	0.6 (0.024)
Rear shock absorber pre-load position	2 / 5 position	—
Rear shock absorber spring length	179.2 (7.07)	175 (6.89)

TIRE PRESSURE

COLD INFLATION TIRE PRESSURE	NORMAL RIDING					
	SOLO RIDING			DUAL RIDING		
	kPa	kg/cm ²	psi	kPa	kg/cm ²	psi
FRONT	196	2.00	29.0	196	2.00	29.0
REAR	221	2.25	32.0	245	2.50	36.0

BRAKE+WHEEL

Unit : mm (in)

ITEM	STANDARD		LIMIT
Rear brake pedal height	290 (11.4) [when one person riding from the ground]		—
Brake disc thickness	Front	4.0 (0.16)	3.0 (0.12)
	Rear	4.3 (0.17)	3.0 (0.12)
Brake disc runout	Front · Rear	—	0.3 (0.012)
Master cylinder bore	Front · Rear	12.700 ~ 12.743 (0.5000 ~ 0.5017)	—
Master cylinder piston diam.	Front · Rear	12.657 ~ 12.684 (0.4983 ~ 0.4994)	—
Brake caliper cylinder bore	Front · Rear	25.4 (1.00)	—
Brake caliper piston diam	Front · Rear	25.4 (1.00)	—
Brake fluid type	DOT3 or DOT4		—
Wheel runout	Axial	—	2.0 (0.08)
	Radial	—	2.0 (0.08)
Wheel axle runout	Front	—	0.25 (0.01)
	Rear	—	0.25 (0.01)
Wheel rim size	Front	J17×MT3.00	—
	Rear	J17×MT4.00	—
Tire tread depth	Front	4.6 (0.18)	1.6 (0.06)
	Rear	6.3 (0.25)	1.6 (0.06)

FUEL + OIL

ITEM	SPECIFICATION		NOTE
Fuel type	Gasoline used should be graded 85-95 octane or higher. An unleaded gasoline is recommended.		
Fuel tank capacity	Including reserve	17 ℓ	
	Reserve	3 ℓ	
Engine oil type	API Over SG (SAE 10W/30 or 10W/40)		
Engine oil capacity (『 Comet-250 』)	Change	1,450 ml	
	Filter change	1,500 ml	
	Overhaul	1,800 ml	
Engine oil capacity (『 Comet-125 』)	Change	1,450 ml	
	Filter change	1,500 ml	
	Overhaul	1,650 ml	

WIRE AND CABLE ROUTING 『 *Comet 250* 』

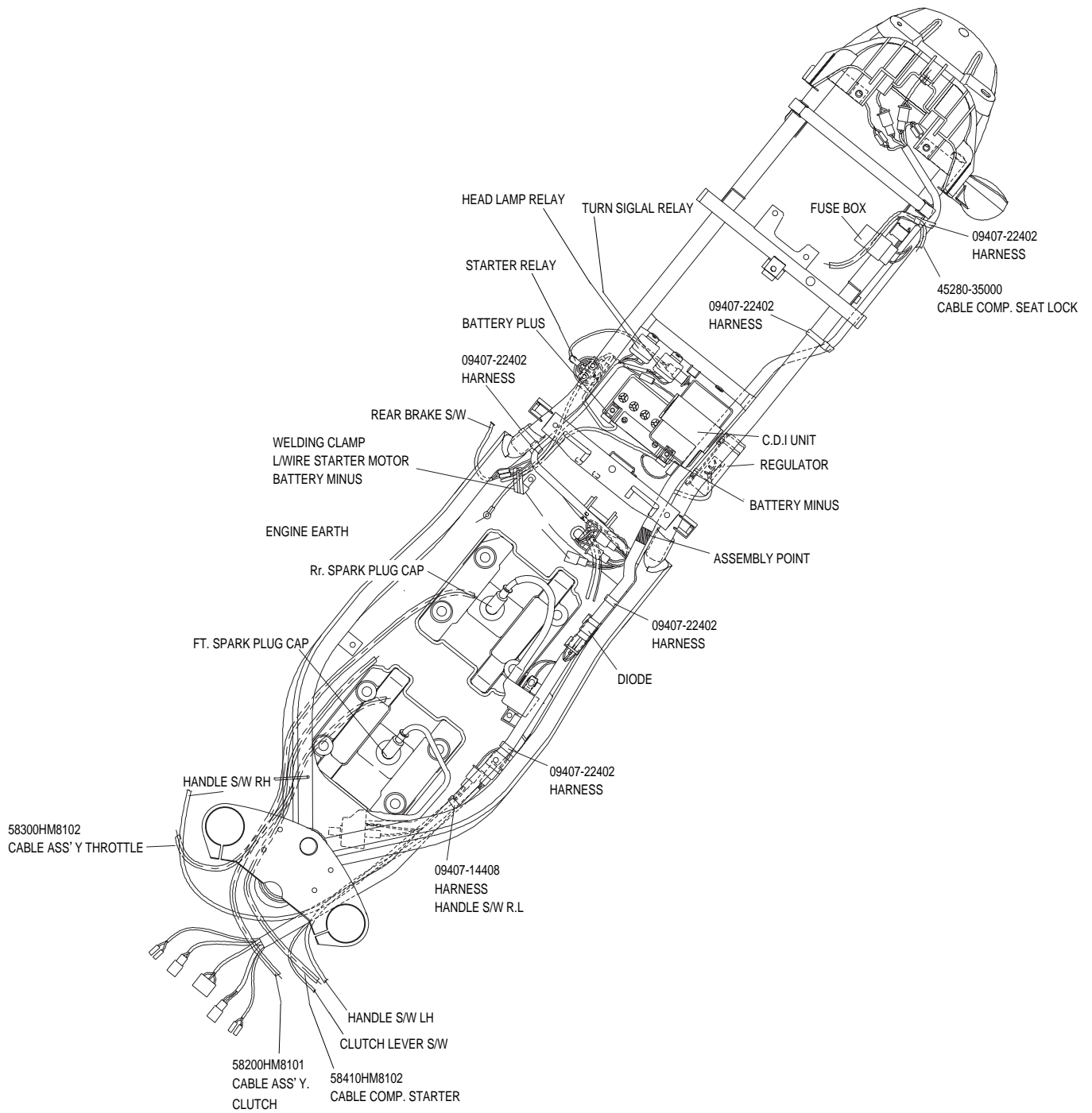

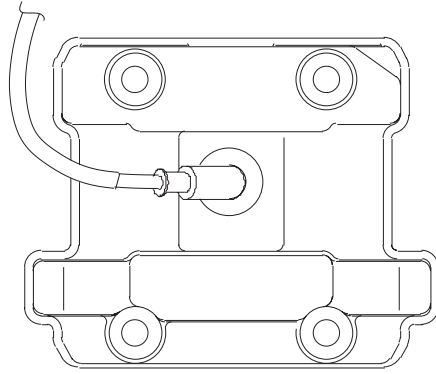
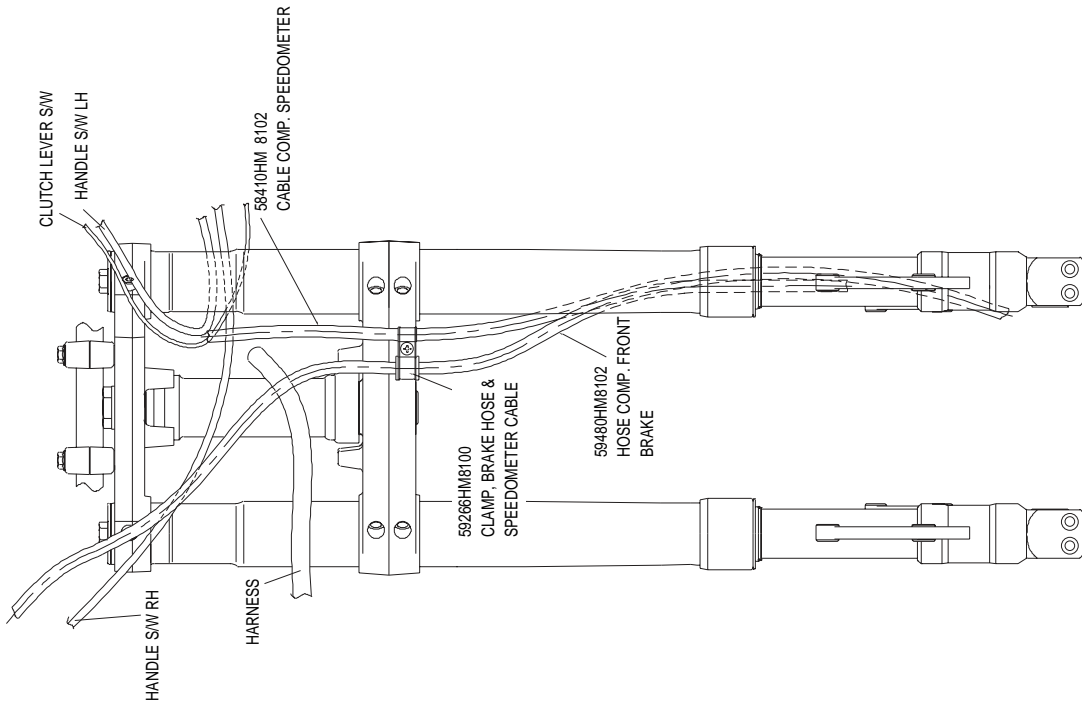

FRONT IGNITION COIL VIEW A

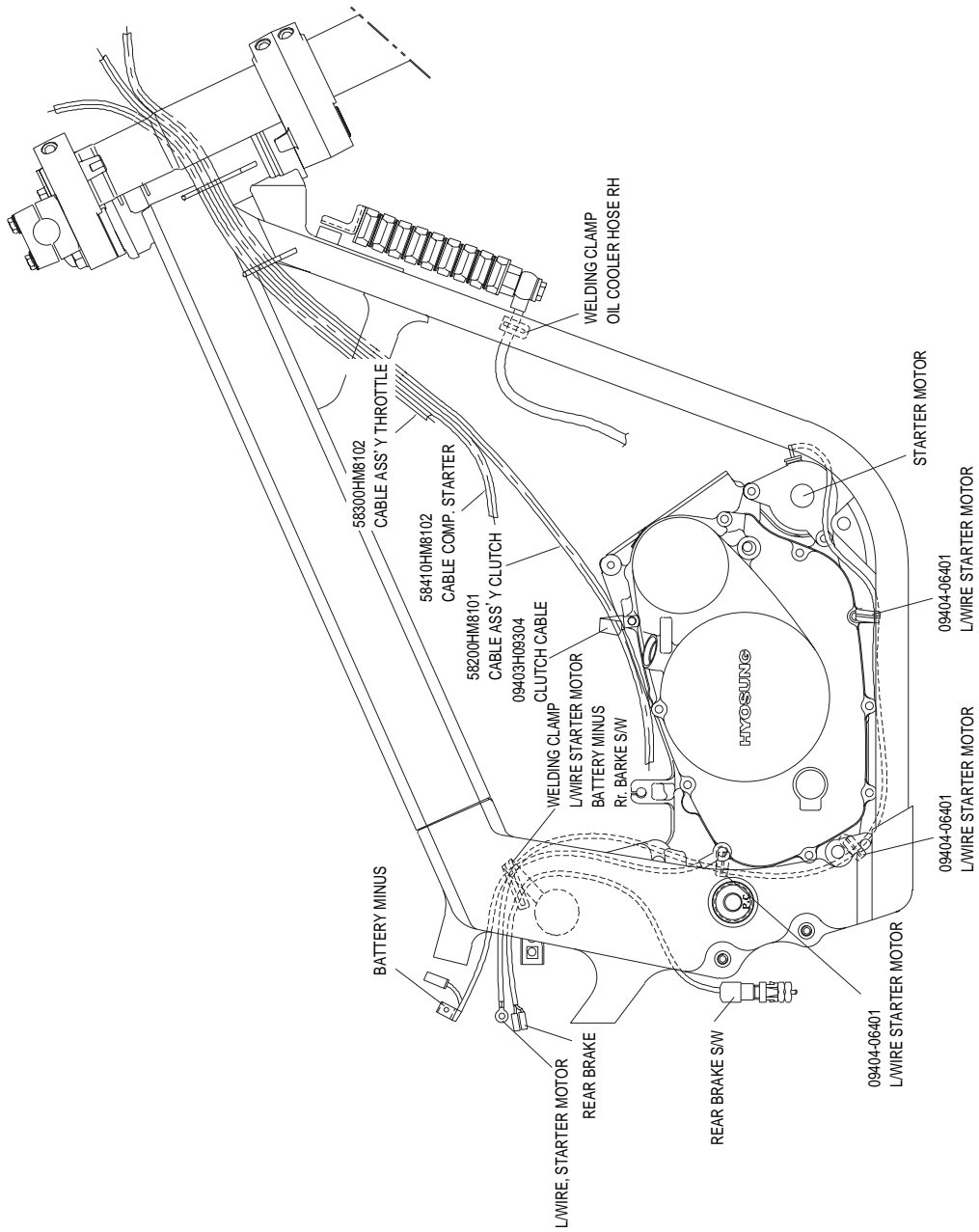

WIRE AND CABLE ROUTING Comet 125

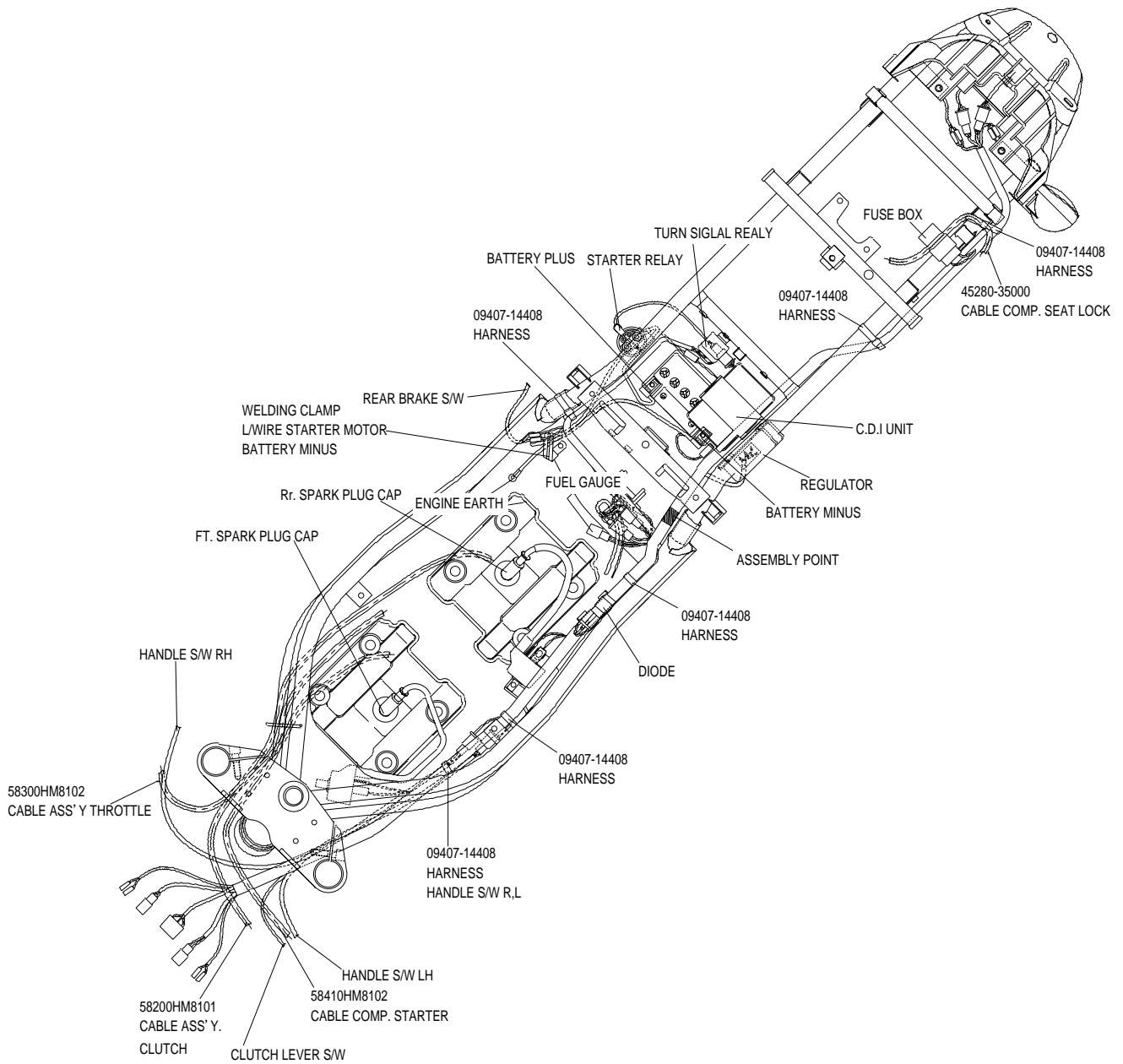

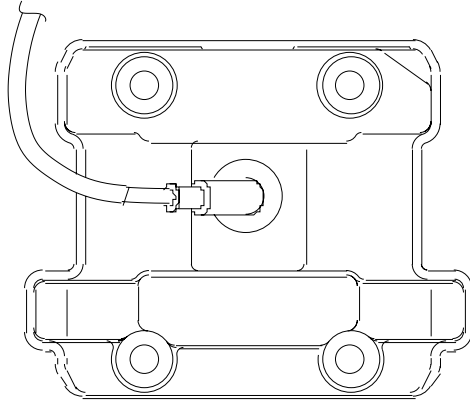
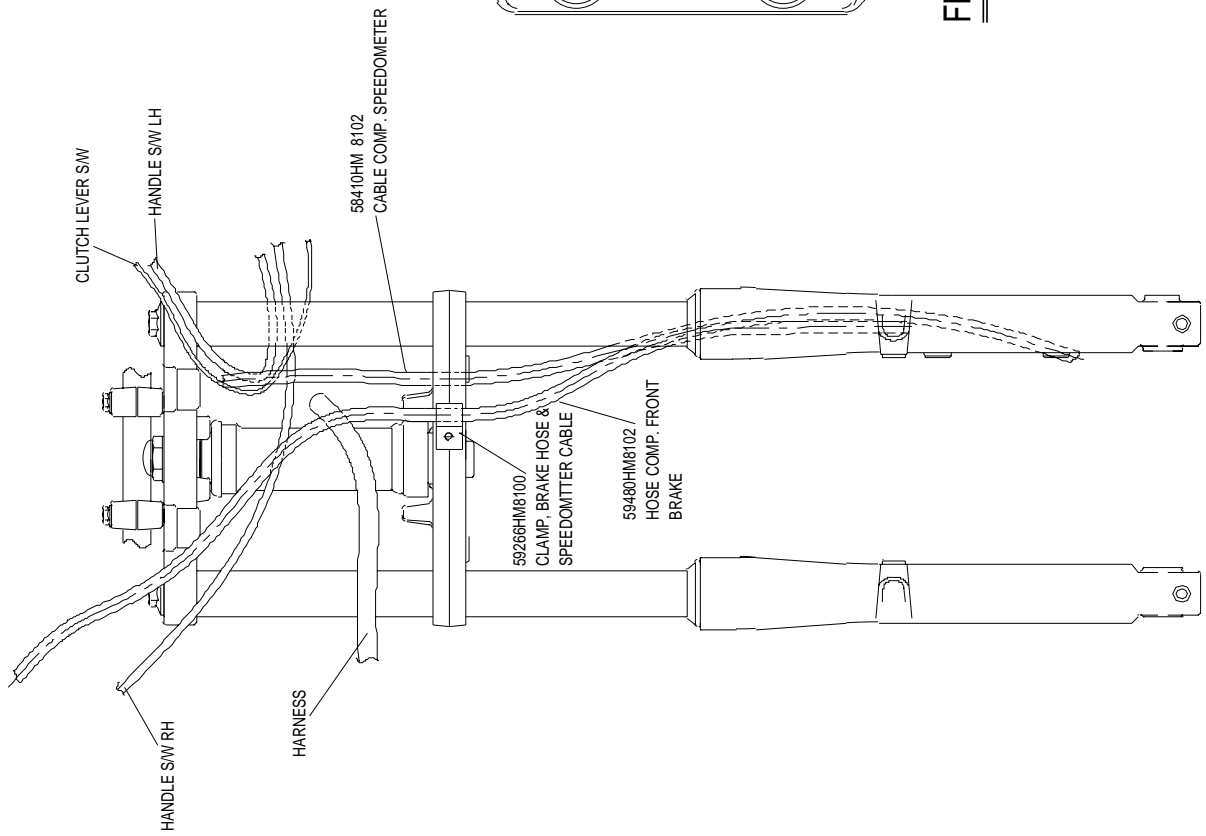

FRONT IGNITION COIL VIEW B

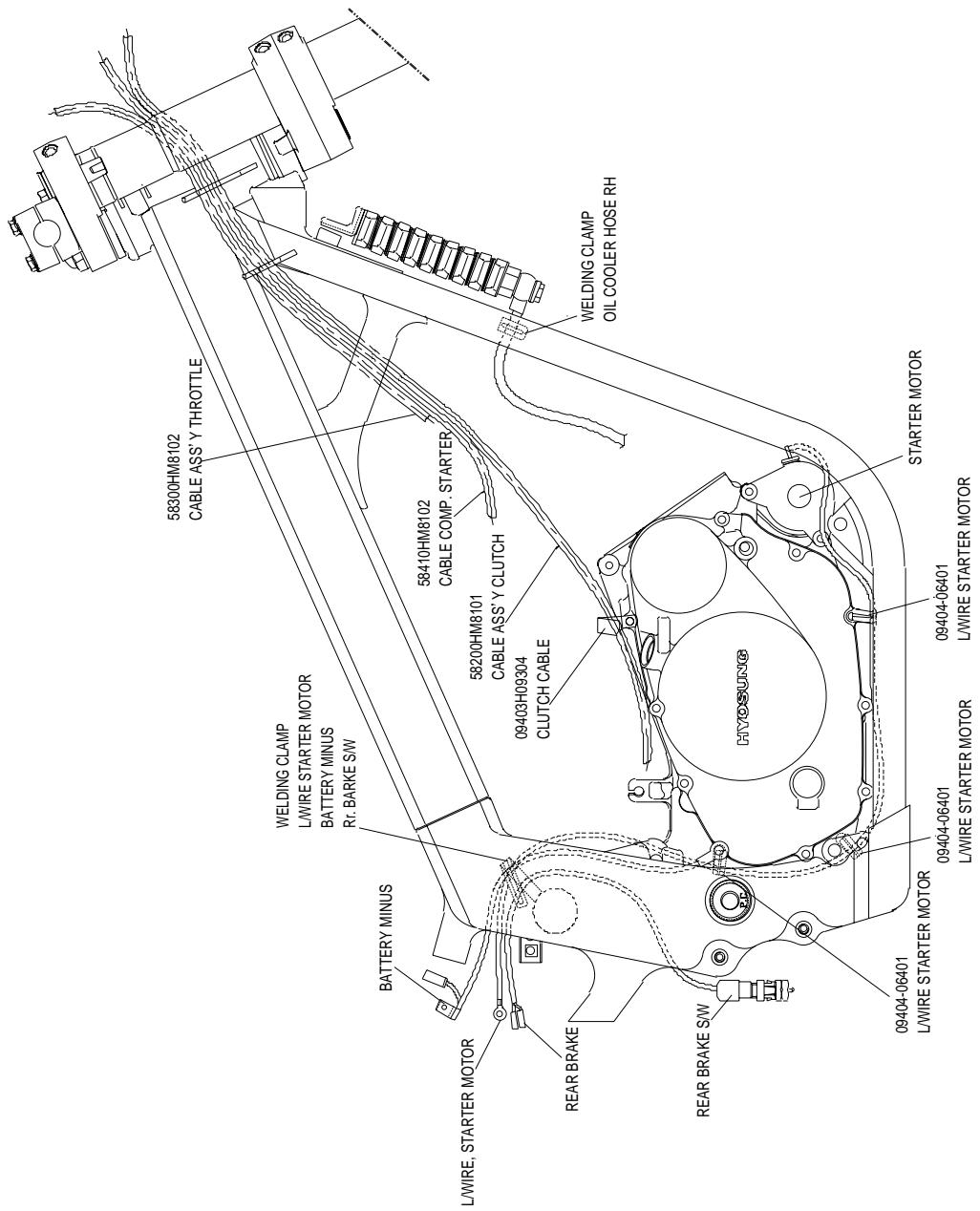

WIRING DIAGRAM *Comet 250*

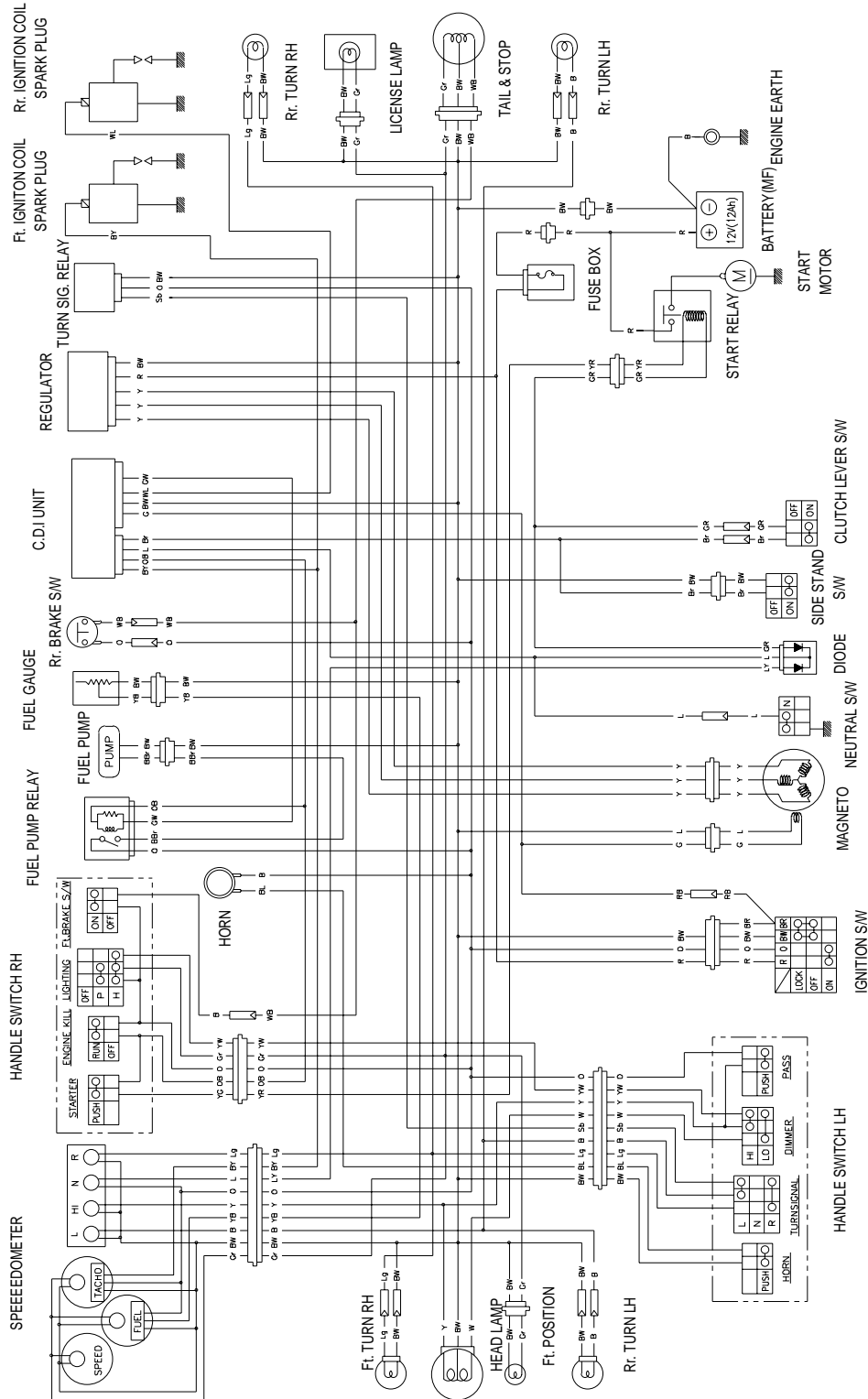

- WIRE COLOR**
- B : Black
 - Br : Brown
 - G : Green
 - Gr : Gray
 - L : Blue
 - Lg : Light green
 - O : Orange
 - R : Red
 - Sb : Light blue
 - W : White
 - Y : Yellow
 - BG : Black with Green tracer
 - BW : Black with White tracer
 - BR : Black with Red tracer
 - LW : Blue with White tracer
 - RB : Red with Black tracer
 - RW : Red with White tracer
 - WB : White with Black tracer
 - WR : White with Red tracer
 - YB : Yellow with Black tracer

WIRING DIAGRAM *Comet 125*

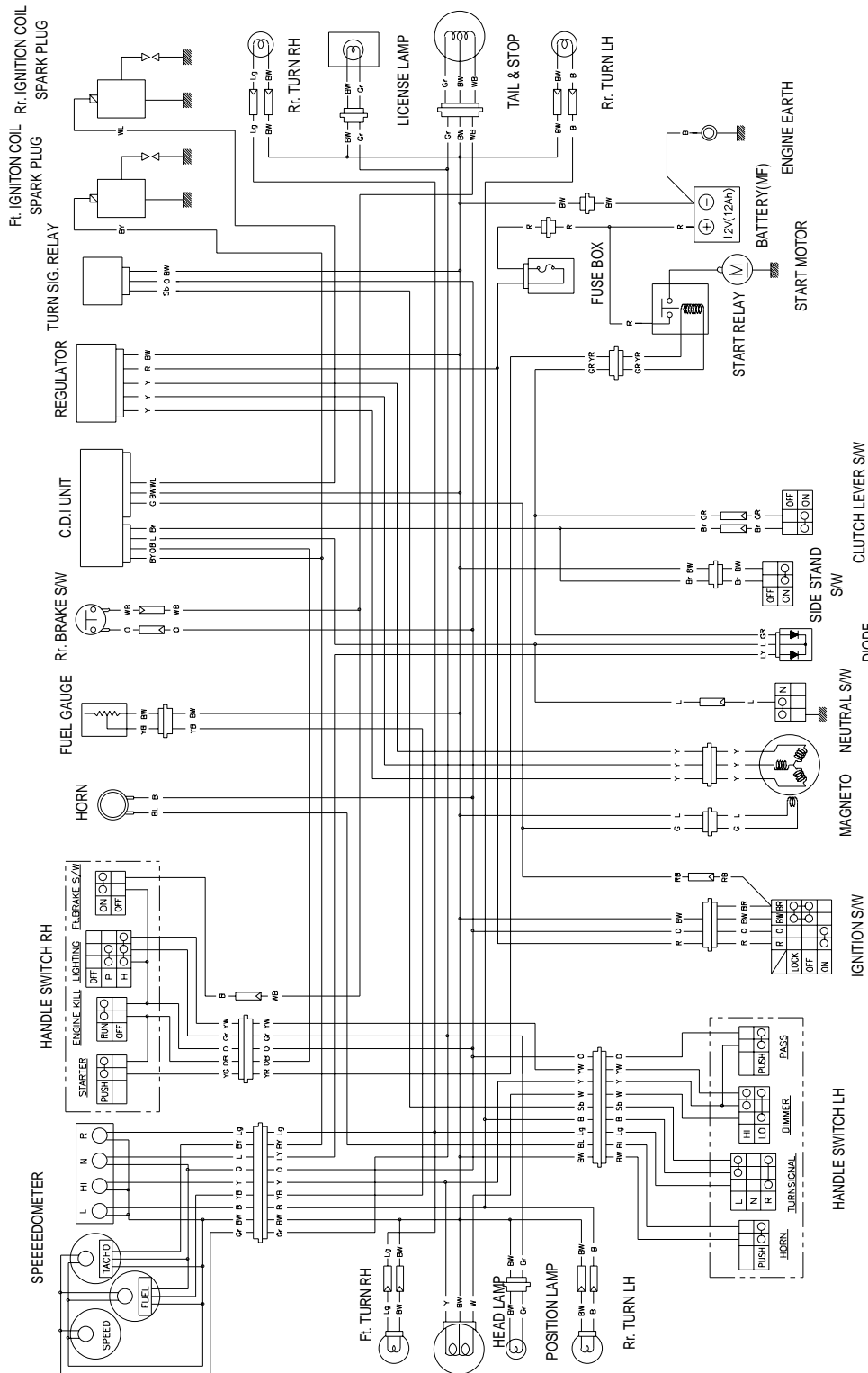

WIRE COLOR

- B : Black
- Br : Brown
- G : Green
- Gr : Gray
- L : Blue
- Lg : Light green
- O : Orange
- R : Red
- Sb : Light blue
- W : White
- Y : Yellow
- BG : Black with Green tracer
- BW : Black with White tracer
- BR : Black with Red tracer
- LW : Blue with White tracer
- RB : Red with Black tracer
- RW : Red with White tracer
- WB : White with Black tracer
- WR : White with Red tracer
- YB : Yellow with Black tracer

TAPPET SHIM SELECTION CHART (IN.)

MEASURING TAPPET CLEARANCE (mm)	SHIM No.		120	125	130	135	140	145	150	155	160	165	170	175	180	185	190	195	200	205	210	215	220
	SHIM THICKNESS AT PRESENT (mm)		1.20	1.25	1.30	1.35	1.40	1.45	1.50	1.55	1.60	1.65	1.70	1.75	1.80	1.85	1.90	1.95	2.00	2.05	2.10	2.15	2.20
0.00-0.04			1.20	1.25	1.30	1.35	1.40	1.45	1.50	1.55	1.60	1.65	1.70	1.75	1.80	1.85	1.90	1.95	2.00	2.05	2.10	2.15	2.20
0.05-0.09			1.20	1.25	1.30	1.35	1.40	1.45	1.50	1.55	1.60	1.65	1.70	1.75	1.80	1.85	1.90	1.95	2.00	2.05	2.10	2.15	2.20
0.10-0.20			1.20	1.25	1.30	1.35	1.40	1.45	1.50	1.55	1.60	1.65	1.70	1.75	1.80	1.85	1.90	1.95	2.00	2.05	2.10	2.15	2.20
0.21-0.25			1.30	1.35	1.40	1.45	1.50	1.55	1.60	1.65	1.70	1.75	1.80	1.85	1.90	1.95	2.00	2.05	2.10	2.15	2.20	2.20	2.20
0.26-0.30			1.35	1.40	1.45	1.50	1.55	1.60	1.65	1.70	1.75	1.80	1.85	1.90	1.95	2.00	2.05	2.10	2.15	2.20	2.20	2.20	2.20
0.31-0.35			1.40	1.45	1.50	1.55	1.60	1.65	1.70	1.75	1.80	1.85	1.90	1.95	2.00	2.05	2.10	2.15	2.20	2.20	2.20	2.20	2.20
0.36-0.40			1.45	1.50	1.55	1.60	1.65	1.70	1.75	1.80	1.85	1.90	1.95	2.00	2.05	2.10	2.15	2.20	2.20	2.20	2.20	2.20	2.20
0.41-0.45			1.50	1.55	1.60	1.65	1.70	1.75	1.80	1.85	1.90	1.95	2.00	2.05	2.10	2.15	2.20	2.20	2.20	2.20	2.20	2.20	2.20
0.46-0.50			1.55	1.60	1.65	1.70	1.75	1.80	1.85	1.90	1.95	2.00	2.05	2.10	2.15	2.20	2.20	2.20	2.20	2.20	2.20	2.20	2.20
0.51-0.55			1.60	1.65	1.70	1.75	1.80	1.85	1.90	1.95	2.00	2.05	2.10	2.15	2.20	2.20	2.20	2.20	2.20	2.20	2.20	2.20	2.20
0.56-0.60			1.65	1.70	1.75	1.80	1.85	1.90	1.95	2.00	2.05	2.10	2.15	2.20	2.20	2.20	2.20	2.20	2.20	2.20	2.20	2.20	2.20
0.61-0.65			1.70	1.75	1.80	1.85	1.90	1.95	2.00	2.05	2.10	2.15	2.20	2.20	2.20	2.20	2.20	2.20	2.20	2.20	2.20	2.20	2.20
0.66-0.70			1.75	1.80	1.85	1.90	1.95	2.00	2.05	2.10	2.15	2.20	2.20	2.20	2.20	2.20	2.20	2.20	2.20	2.20	2.20	2.20	2.20
0.71-0.75			1.80	1.85	1.90	1.95	2.00	2.05	2.10	2.15	2.20	2.20	2.20	2.20	2.20	2.20	2.20	2.20	2.20	2.20	2.20	2.20	2.20
0.76-0.80			1.85	1.90	1.95	2.00	2.05	2.10	2.15	2.20	2.20	2.20	2.20	2.20	2.20	2.20	2.20	2.20	2.20	2.20	2.20	2.20	2.20
0.81-0.85			1.90	1.95	2.00	2.05	2.10	2.15	2.20	2.20	2.20	2.20	2.20	2.20	2.20	2.20	2.20	2.20	2.20	2.20	2.20	2.20	2.20
0.86-0.90			1.95	2.00	2.05	2.10	2.15	2.20	2.20	2.20	2.20	2.20	2.20	2.20	2.20	2.20	2.20	2.20	2.20	2.20	2.20	2.20	2.20
0.91-0.95			2.00	2.05	2.10	2.15	2.20	2.20	2.20	2.20	2.20	2.20	2.20	2.20	2.20	2.20	2.20	2.20	2.20	2.20	2.20	2.20	2.20
0.96-1.00			2.05	2.10	2.15	2.20	2.20	2.20	2.20	2.20	2.20	2.20	2.20	2.20	2.20	2.20	2.20	2.20	2.20	2.20	2.20	2.20	2.20
1.01-1.05			2.10	2.15	2.20	2.20	2.20	2.20	2.20	2.20	2.20	2.20	2.20	2.20	2.20	2.20	2.20	2.20	2.20	2.20	2.20	2.20	2.20
1.06-1.10			2.15	2.20	2.20	2.20	2.20	2.20	2.20	2.20	2.20	2.20	2.20	2.20	2.20	2.20	2.20	2.20	2.20	2.20	2.20	2.20	2.20
1.11-1.15			2.20	2.20	2.20	2.20	2.20	2.20	2.20	2.20	2.20	2.20	2.20	2.20	2.20	2.20	2.20	2.20	2.20	2.20	2.20	2.20	2.20

Specified clearance - Adjustment unnecessary

HOW TO USE THE CHART

1. Measure the tappet clearance. (When cold)
2. Measure the shim thickness at present.
3. Look for meeting space in that horizontal line for thickness and vertical line for clearance.

(EXAMPLE)

When the tappet clearance is 0.23mm and the shim thickness at present is 1.70mm, the shim thickness should be used 1.80mm.

TAPPET SHIM SELECTION CHART (EX.)

MEASURING TAPPET CLEARANCE (mm)	SHIM No.		120	125	130	135	140	145	150	155	160	165	170	175	180	185	190	195	200	205	210	215	220
	SHIM THICKNESS AT PRESENT (mm)		1.20	1.25	1.30	1.35	1.40	1.45	1.50	1.55	1.60	1.65	1.70	1.75	1.80	1.85	1.90	1.95	2.00	2.05	2.10	2.15	2.20
0.05-0.09						1.20	1.25	1.30	1.35	1.40	1.45	1.50	1.55	1.60	1.65	1.70	1.75	1.80	1.85	1.90	1.95	2.00	2.05
0.10-0.14				1.20	1.25	1.30	1.35	1.40	1.45	1.50	1.55	1.60	1.65	1.70	1.75	1.80	1.85	1.90	1.95	2.00	2.05	2.10	2.15
0.15-0.19			1.20	1.25	1.30	1.35	1.40	1.45	1.50	1.55	1.60	1.65	1.70	1.75	1.80	1.85	1.90	1.95	2.00	2.05	2.10	2.15	2.20
0.20-0.30	Specified clearance - Adjustment unnecessary																						
0.31-0.35			1.30	1.35	1.40	1.45	1.50	1.55	1.60	1.65	1.70	1.75	1.80	1.85	1.90	1.95	2.00	2.05	2.10	2.15	2.20	2.20	2.20
0.36-0.40			1.35	1.40	1.45	1.50	1.55	1.60	1.65	1.70	1.75	1.80	1.85	1.90	1.95	2.00	2.05	2.10	2.15	2.20	2.20	2.20	2.20
0.41-0.45			1.40	1.45	1.50	1.55	1.60	1.65	1.70	1.75	1.80	1.85	1.90	1.95	2.00	2.05	2.10	2.15	2.20	2.20	2.20	2.20	2.20
0.46-0.50			1.45	1.50	1.55	1.60	1.65	1.70	1.75	1.80	1.85	1.90	1.95	2.00	2.05	2.10	2.15	2.20	2.20	2.20	2.20	2.20	2.20
0.51-0.55			1.50	1.55	1.60	1.65	1.70	1.75	1.80	1.85	1.90	1.95	2.00	2.05	2.10	2.15	2.20	2.20	2.20	2.20	2.20	2.20	2.20
0.56-0.60			1.55	1.60	1.65	1.70	1.75	1.80	1.85	1.90	1.95	2.00	2.05	2.10	2.15	2.20	2.20	2.20	2.20	2.20	2.20	2.20	2.20
0.61-0.65			1.60	1.65	1.70	1.75	1.80	1.85	1.90	1.95	2.00	2.05	2.10	2.15	2.20	2.20	2.20	2.20	2.20	2.20	2.20	2.20	2.20
0.66-0.70			1.65	1.70	1.75	1.80	1.85	1.90	1.95	2.00	2.05	2.10	2.15	2.20	2.20	2.20	2.20	2.20	2.20	2.20	2.20	2.20	2.20
0.71-0.75			1.70	1.75	1.80	1.85	1.90	1.95	2.00	2.05	2.10	2.15	2.20	2.20	2.20	2.20	2.20	2.20	2.20	2.20	2.20	2.20	2.20
0.76-0.80			1.75	1.80	1.85	1.90	1.95	2.00	2.05	2.10	2.15	2.20	2.20	2.20	2.20	2.20	2.20	2.20	2.20	2.20	2.20	2.20	2.20
0.81-0.85			1.80	1.85	1.90	1.95	2.00	2.05	2.10	2.15	2.20	2.20	2.20	2.20	2.20	2.20	2.20	2.20	2.20	2.20	2.20	2.20	2.20
0.86-0.90			1.85	1.90	1.95	2.00	2.05	2.10	2.15	2.20	2.20	2.20	2.20	2.20	2.20	2.20	2.20	2.20	2.20	2.20	2.20	2.20	2.20
0.91-0.95			1.90	1.95	2.00	2.05	2.10	2.15	2.20	2.20	2.20	2.20	2.20	2.20	2.20	2.20	2.20	2.20	2.20	2.20	2.20	2.20	2.20
0.96-1.00			1.95	2.00	2.05	2.10	2.15	2.20	2.20	2.20	2.20	2.20	2.20	2.20	2.20	2.20	2.20	2.20	2.20	2.20	2.20	2.20	2.20
1.01-1.05			2.00	2.05	2.10	2.15	2.20	2.20	2.20	2.20	2.20	2.20	2.20	2.20	2.20	2.20	2.20	2.20	2.20	2.20	2.20	2.20	2.20
1.06-1.10			2.05	2.10	2.15	2.20	2.20	2.20	2.20	2.20	2.20	2.20	2.20	2.20	2.20	2.20	2.20	2.20	2.20	2.20	2.20	2.20	2.20
1.11-1.15			2.10	2.15	2.20	2.20	2.20	2.20	2.20	2.20	2.20	2.20	2.20	2.20	2.20	2.20	2.20	2.20	2.20	2.20	2.20	2.20	2.20
1.16-1.20			2.15	2.20	2.20	2.20	2.20	2.20	2.20	2.20	2.20	2.20	2.20	2.20	2.20	2.20	2.20	2.20	2.20	2.20	2.20	2.20	2.20
1.21-1.25			2.20	2.20	2.20	2.20	2.20	2.20	2.20	2.20	2.20	2.20	2.20	2.20	2.20	2.20	2.20	2.20	2.20	2.20	2.20	2.20	2.20

HOW TO USE THE CHART

1. Measure the tappet clearance. (When cold)
2. Measure the shim thickness at present.
3. Look for meeting space in that horizontal line for thickness and vertical line for clearance.

(EXAMPLE)

When the tappet clearance is 0.33mm and the shim thickness at present is 1.70mm, the shim thickness should be used 1.80mm.



Prepared by

HYOSUNG MOTORS & MACHINERY INC.

Overseas Technical Department

1st Ed. NOV. 2002.

Manual No. 99000-94710

Printed in Korea