



OWNER'S MANUAL

MS3 250

MS3 125



WARNING

This owner's manual contains important safety information.
Please read it carefully.

This manual should be considered a permanent part of the motorcycle and should remain with the motorcycle when resold or otherwise transferred to a new owner or operator. The manual contains important safety information and instructions which should be read carefully before operating the motorcycle.

FOREWORD

THANK YOU for choosing **Hyosung** motorcycle. We at **Hyosung** have designed, tested and produced these motorcycles using the most modern technology available to provide you with much happy, enjoyable, safe riding. Motorcycling is one of the most exhilarating sports and insure your riding enjoyment, you should become thoroughly familiar with the information presented in this Owner's Manual before riding the motorcycle.

The proper care and maintenance that your motorcycle requires are outlined in this manual.

By following these instructions explicitly you will insure a long trouble-free operating life for your motorcycle. Your Hyosung dealer has experienced technicians that are trained to provide your machine with the best possible service with the right tools and equipment.

All information, illustrations photographs and specifications contained in this manual are based on the latest product information available at the time of publication. Due to improvements or other changes, there may be some discrepancies in this manual. Hyosung reserves the right to make changes at any time.

Please note that this manual applies to all specifications for all respective destinations and explains all equipments. Therefore, your model may have different standard features than shown in this manual.



© COPYRIGHT S&T Motors Co., Ltd.

IMPORTANT

BREAK-IN INFORMATION FOR YOUR MOTORCYCLE

The first 1,600 km (1,000 miles) are the most important in the life of your motorcycle.

Proper break-in operation during this time will help ensure maximum life and performance from your new motorcycle.

Hyosung parts are manufactured of high quality materials, and manufactured parts are finished to close tolerances. Proper break-in operation allows the machined surfaces to polish each other and mate smoothly.

Motorcycle reliability and performance depend on special care and restraint exercise during the break-in period. It is especially important that you avoid operating the engine in a manner which could expose the engine parts to excessive heat.

Please refer to the BREAK-IN section for specific break-in recommendations.

WARNING / CAUTION / NOTE

Please read this manual and follow its instructions carefully.

To emphasize special information the words 「WARNING」, 「CAUTION」 and 「NOTE」 have special meanings.

Information following these signal words should be carefully reviewed.



WARNING

The personal safety of the rider may be involved. Disregarding this information could result in injury to the rider.



CAUTION

These instructions point out special service procedures or precautions that must be followed to avoid damaging the machine.

N O T E

This provides special information to make maintenance easier or important instructions clearer.



WARNING

Noise Control System (muffler assembly)

TAMPERING WITH NOISE CONTROL SYSTEM PROHIBITED

Owners are warned that the law may prohibit :

- (a) The removal or rendering inoperative by any person other than for the purpose of maintenance, repair or replacement, of any device or element of design incorporated into any new vehicle for the purpose of noise control prior to its any sale or delivery to the ultimate purchaser or while it is in use ; and
- (b) The use of the vehicle after such device or element of design has been removed or rendered inoperative by any person.

MAINTENANCE :

The exhaust system of this motorcycle requires no periodic maintenance. The engine should be adjusted to the manufacture's specifications and the spark plug should be kept in good condition. Running the engine with incorrectly operating spark plug or misadjusted carburetor may cause permanent damage to the catalyst and to the noise control system.

CONSUMER INFORMATION

SAFE RIDING RECOMMENDATION FOR MOTORCYCLE RIDERS

Motorcycle riding is great fun and an exciting sport. Motorcycle riding also requires that some extra precautions be taken to ensure the safety of the rider and passenger. These precautions are :



WARNING

- Before first use of the 『**MSA** **ESD / IES**』 read this owner's manual carefully to become familiar with the 『**MSA** **ESD / IES**』's features, and safety and maintenance requirements. Review all instructions, requirements and warnings with the riders. Keep the owner's manual in the owner's manual storage compartment located under the seat.
- Before the rider's first use of the 『**MSA** **ESD / IES**』, make sure that he / she is familiar with the location and operation of all controls, and has been instructed in the proper operation of the motorcycle.
- For first use of the 『**MSA** **ESD / IES**』, find a level, open area for the rider to use to become familiar with the operation of controls and the operating and handling characteristics of the 『**MSA** **ESD / IES**』.



WARNING

- Before each use, perform daily inspections with the rider. Specific items to check are listed in the **INSPECTION BEFORE RIDING** section on page 52 of this owner's manual.
- Make sure the rider wears a helmet, eye protection, and protective clothing (gloves, leather or heavy cloth pants, long sleeved shirt or jacket, boots).
- Permit use only by dual rider. These motorcycles are designed for use only by dual rider.
- Do not permit anyone to operate the 『**MSA** **ESD / IES**』 under the influence of alcohol or other drugs caused by damage to the motorcycle or altered handling characteristics.
- Observe periodic maintenance requirements your authorized HYOSUNG dealer is trained and equipped to perform this service.
- Drain gasoline from the fuel tank prior to transporting the 『**MSA** **ESD / IES**』.
- Caution the rider and others near the 『**MSA** **ESD / IES**』 not to get close to or touch any moving parts or any heated areas such as the engine and exhaust system.
- Do not make any modifications to the 『**MSA** **ESD / IES**』. Modifications may make the motorcycle unsafe or illegal in your state.
- Never operate at excessive speed. Always go at a speed that is proper for terrain, visibility and operating conditions, your skill and experience.
- Never attempt stunts.

CAUTION

These motorcycles always come on the head lamp, position lamp, meter lamp, tail lamp and license plate lamp when the ignition switch is turned to the “”(ON) position.

WARNING

- Do not run the engine indoors or where there is little or no ventilation. Exhaust gases contain carbon monoxide, a potentially lethal gas that is colorless and odorless.
- Never leave the motorcycle running while unattended, even for a short time.

WARNING

While operating the 『』, the rider should keep both feet on the footrests at all times, or injuries resulting from accidents. Moving the rider's feet from the footrests reduces the rider's ability to control the motorcycle, and could lead to an accident.

WARNING

Keep both hands on the handgrips at all times when riding. Removing your hands from the handgrips reduces your ability to control the motorcycle, and could result in an accident.

WARNING

Always open the throttle gradually to prevent front wheel lifting. Failure to observe this precaution may result in loss of control and an accident.

CAUTION

WHEN KEEPING FOR LONG PERIOD :



1. Supply the enough fuel in the fuel tank.
2. Remove the battery from the motorcycle.

CAUTION

- The trunk could be heated. Don't keep anything that doesn't endure heat.
- Don't keep the fragile.
- Check if it is locked.
- The unlocking of trunk could cause serious accident.
- Don't allow water to get inside the trunk or it could damage.
- Don't keep the valuables in the trunk when leaving unattended.
- Loading limit of front storage box : 1.5 kg (3.3 lbs)
- Loading limit of personal trunk : 10 kg (22.1 lbs)
- Loading limit of rear carrier : 5 kg (11.0 lbs)
- Exceed loading limit may result in injury caused by damage to the vehicle or altered handling characteristics.



WARNING

Do not operate the ignition switch in the “” (OFF) or “” (LOCK) position or the engine stop switch in the “” position while driving at one’s pleasure.

⦿ WEAR A HELMET



WARNING

Motorcycle safety equipment starts with a quality safety helmet. One of the most serious injuries that can happen is a head injury. ALWAYS wear a properly approved helmet. You should also wear a suitable eye protection.

⦿ RIDING APPAREL



WARNING

Loose fancy clothing can be uncomfortable and unsafe in terms of riding your motorcycle. Choose good quality motorcycle riding apparel in terms of riding your motorcycle.

⦿ INSPECTION BEFORE RIDING



WARNING

Review thoroughly the instructions in the “INSPECTION BEFORE RIDING” section of this manual. Do not forget to perform an entire safety inspection to ensure the safety of the rider and its passenger.

⦿ FAMILIARIZE YOURSELF WITH THE MOTORCYCLE



WARNING

Your riding skill and mechanical knowledge from the foundation for safe riding practices.

We suggest that you practice riding your motorcycle in a non-traffic situation until you are thoroughly familiar with your machine and its controls. Remember practice makes perfect.

⦿ KNOW YOUR LIMITS



WARNING

Ride within the boundaries of your own skill at all times. Knowing these limits and staying within them will help you to avoid accidents.

⦿ BE EXTRA SAFETY CONSCIOUS ON BAD WEATHER DAYS



WARNING

Riding on bad weather days, especially wet ones, requires extra caution. Braking distances double on a rainy day. Stay off of the painted surface marks, manhole covers and greasy appearing areas as they can be especially slippery.

Use extreme caution at railway crossings and on metal gratings and bridges. Whenever you have a doubt about road condition, slow down!

⊙ RIDE DEFENSIVELY



WARNING

The most common type of motorcycle accident occurs when a car traveling towards a motorcycle turns round corner in front of the motorcyclist.

Ride defensively.

Wise motorcyclist uses a strategy of assuming they are invisible to other drivers, even in broad daylight.

Wear bright, reflecting clothing.

Do not ride in another driver's blind spot.

ACCESSORY INSTALLATION AND PRECAUTION SAFETY TIPS

There are a great variety of accessories available to **Hyosung** owners. **Hyosung** can not have direct control over the quality or suitability of accessories you may wish to purchase except genuine parts.

The addition of unsuitable accessories can lead to unsafe operating conditions. It is not possible for **Hyosung** to test each accessory on the market or combinations of all the available accessories, however, your dealer can assist you in selecting quality accessories and installing them correctly.

Use extreme caution when selecting and installing the accessories for your **Hyosung**. We have developed some general guidelines which will aid you when deciding whether, and how to equip your motorcycle.



WARNING

Improper accessories or modifications can make your motorcycle unsafe and can lead to an accident.

Never modify the motorcycle with improper or poorly installed accessories. Follow all instructions in this owner's manual regarding accessories and modifications. Use genuine Hyosung accessories or equivalent designed and tested for your motorcycle. Consult your Hyosung dealer if you have any questions.

1. Anytime that additional weight or aerodynamic affecting accessories are installed, they should be mounted as low as possible, as close to the motorcycle and as near the center of gravity as is feasible. The mounting brackets and other attachment hardware should be carefully checked to ensure that it provides for a rigid, nonmovable mount. Weak mounts can allow the shifting of the weight and create a dangerous, unstable condition.
2. Inspect for proper ground clearance and bank angle. An improperly mounted load could critically reduce these two safety factors. Also determine that the "load" does not interfere with the operation of the suspension, steering or other control operations.
3. Accessories fitted to the handlebars or the front fork area can create serious stability problems. This extra weight will cause the motorcycle to be less responsive to your steering control. The weight may also cause oscillations in the front end and lead to instability problems. Accessories added to the machine should be as light as possible and kept to a minimum.
4. The motorcycle may be affected by a lifting condition or by an instability in cross winds or when being passed or passing large vehicles. Improperly mounted or poorly designed accessories can result in an unsafe riding condition, therefore caution should be used when selecting and installing all accessories.
5. Certain accessories displace the rider from his or her normal riding position.

This limits the freedom of movement of the rider and may limit his or her control ability.

6. Additional electrical accessories may damage the existing electrical system. Severe overloads may damage the wiring harness or create a dangerous situation due to the loss of electrical power during the operation of the motorcycle.

When carrying a load on the motorcycle, mount it as low as possible and as close as possible to the machine. An improperly mounted load can create a high center of gravity which is very dangerous and makes the motorcycle difficult to handle. The size of the "load" can also affect the aerodynamics and handling of the motorcycle.

Balance the load between the left and right side of the motorcycle and fasten it securely.

MODIFICATION

Modification of the motorcycle, or removal of original equipment may render the motorcycle unsafe or illegal.

Obey all applicable equipment regulations in your area.

TABLE OF CONTENTS

1. SERIAL NUMBER LOCATION	12
2. FUEL , OIL AND COOLANT RECOMMENDATION	13
FUEL	
ENGINE OIL	
TRANSMISSION OIL	
ENGINE COOLANT SOLUTION	
3. NAMES OF EACH PARTS	16
4. CONTROLS	19
IGNITION SWITCH	
IGNITION KEY	
INSTRUMENT PANEL	
LEFT HANDLE SWITCHES	
RIGHT HANDLE SWITCHES	
STAND	
5. HOW TO USE	28
HOW TO OPEN THE SEAT	
HOW TO USE THE PERSONAL TRUNK	
HOW TO OPEN THE FRONT STORAGE BOX	
HOW TO USE THE OUTPUT TERMINAL	
6. SUPPLY OF GASOLINE , OIL AND COOLANT	31
GASOLINE	
ENGINE OIL	
TRANSMISSION OIL	
ENGINE COOLANT	
7. THE PROPER OPERATIONS	41
STARTING THE ENGINE	
STARTING OFF	
OPERATING THE BRAKE	
STOPPING AND PARKING	
8. BREAK-IN	51
9. INSPECTION BEFORE RIDING	52

10. PERIODIC MAINTENANCE 54

11. INSPECTION AND MAINTENANCE 58

- TOOL
- ENGINE OIL
- TRANSMISSION OIL
- GASOLINE
- FUEL HOSE
- COOLANT
- RADIATOR
- RUBBER CAP OF CABLES
- EXHAUST PIPE AND MUFFLER
- REAR-VIEW MIRROR
- REFLECTOR
- BRAKES
- TIRES
- AIR CLEANER
- FRONT AND REAR SUSPENSIONS
- CHECKING THE STEERING
- CHECKING THE ENGINE PIVOT
- SIDE COVER STAY
- HELMETBOX INNER COVER
- PASSENGER BACKREST
- IDLING ADJUSTMENT
- ADJUSTING THE THROTTLE CABLE
- SPARK PLUG
- BATTERY
- HEAD LAMP
- BULBS
- TROUBLESHOOTING
- TRANSPORT
- CLEANING PROCEDURE
- STORAGE PROCEDURE

11. LABEL 85

12. SPECIFICATIONS 88

SERIAL NUMBER LOCATION

The frame and/or engine serial numbers are used to register the motorcycle. They are also to assist your dealer in terms of ordering parts or referring to special service information.

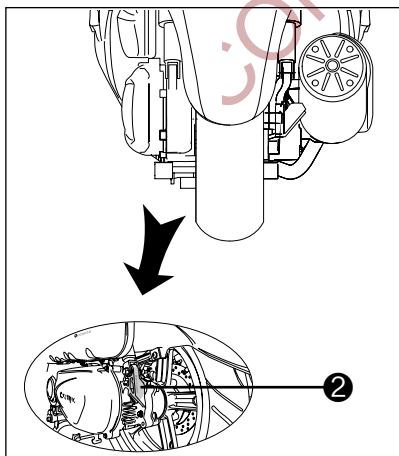
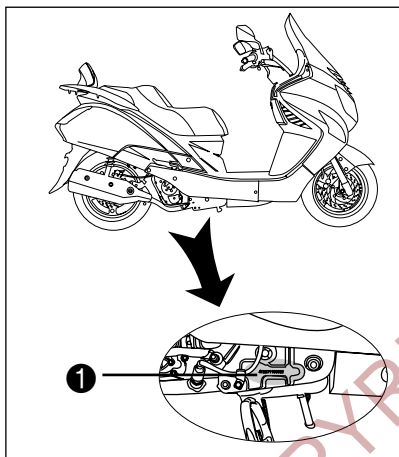

The frame serial number ① is stamped on the right downside frame.

The engine serial number ② is stamped on the left rearside of the crankcase assembly.

Please write down the numbers in the box provided below for your future reference.

Frame number :

Engine number :

FUEL, OIL AND COOLANT RECOMMENDATION

FUEL

Use unleaded gasoline with an octane rating of 91 or higher.

Unleaded gasoline can extend spark plug life and exhaust components life.

CAUTION

Spilling gasoline can damage the painted surfaces.

Be careful not to spill any fuel when filling the fuel tank.

Wipe spilled gasoline up immediately.

WARNING

- When refueling, always shut the engine off and turn the ignition key to the "OFF" position. Never refuel near the flames, sparks and heat sources.
- Do not overfill the fuel tank. Do not fill gasoline above the fuel tank entrance lower end.

ENGINE OIL

ENGINE OIL SPECIFICATION

Classification system	Grade	Remarks
API	Over SL	
SAE	10W/40	

※ If a SAE 10W/40 motor oil is not available, select alternative according to the following chart.

ENGINE OIL	Temperature	
	°C	°F
20W50	-30 to 40	-22 to 104
15W40 15W50	-20 to 40	-4 to 104
10W40 10W50	-10 to 40	14 to 104
10W30	0 to 40	32 to 104
5W30	-30 to 0	-22 to 32

Use the chart to select a viscosity rating based on temperature range in your area.

NOTE

In very cold weather [below -15°C (5°F)], use SAE 5W/30 for good starting and smooth operation.

Using a premium quality four stroke motor oil will increase the service life of your motorcycle.



WARNING

- Don't mix the unrecommended oil. It could damage the engine.
- When refilling the oil, don't allow the dust to get inside.
- Wipe the spilled oil up immediately.
- Don't put the patch on the filler cap. It could disturb the oil to be provided and damage the engine.

TRANSMISSION OIL

Use a good quality SAE 10W/40 multi-grade oil.



WARNING

- Don't mix the unrecommended oil. It could damage the engine.
- When refilling the oil, don't allow the dust to get inside.
- Wipe the spilled oil up immediately.
- Don't put the patch on the filler cap. It could disturb the oil to be provided and damage the transmission.

COPYRIGHT

ENGINE COOLANT SOLUTION

Use an engine coolant that is compatible with aluminum radiator, mixed with distilled water only at a 50 : 50 mixture ratio for engine coolant solution.

An engine coolant mixture other than 50 : 50 can affect cooling efficiency or rust inhibiting performance.



WARNING

Engine coolant is harmful or fatal if swallowed or inhaled.

Do not drink anti-freeze or coolant solution. If swallowed, do induce vomiting. Immediately contact a poison control center or a physician. Avoid inhaling mist or hot vapors ; if inhaled, remove to fresh air. If coolant gets in eyes, flush eyes with water and seek medical attention. Wash thoroughly after handling. Solution can be poisonous to animals.

Keep out of the reach of children and animals.

CAUTION

Spilled engine coolant can damage painted surfaces.

Do not spill any fluid when filling the radiator. Wipe spilled engine coolant up immediately.

WATER FOR MIXING

Use distilled water only.

Water other than distilled water can corrode and clog the aluminum radiator.

ENGINE COOLANT

The engine coolant performs as rust inhibitor and water pump lubricant as well as anti-freeze.

Therefore the engine coolant should be used at all times even though the atmospheric temperature in your area does not go down to freezing point.

Required amount of water / coolant

Solution capacity (total)	1.2ℓ
---------------------------	------

50%	Water	0.6ℓ
	Engine coolant	0.6ℓ

NOTE

This 50% mixture will protect the cooling system from freezing at temperatures above -31°C .

If the motorcycle is to be exposed to temperature below -31°C , this mixing ratio should be increased up to 55% (-40°C) or 60% (-55°C). The mixing ratio should not exceed 60%.

COOLANT RESERVOIR TANK

☞ Refer to 39 page.

NAMES OF EACH PARTS

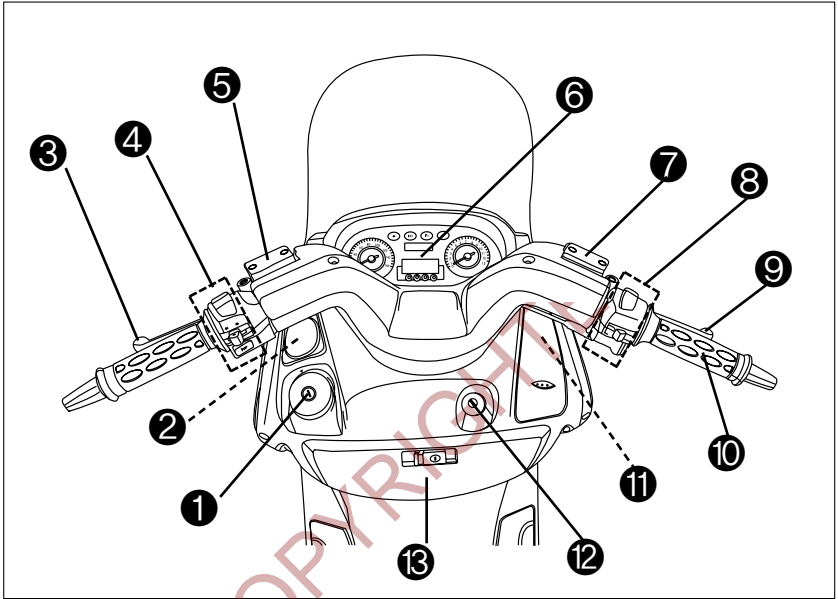

- | | |
|-------------------------------|------------------------------|
| ① Fuel tank cap | ⑧ Right handle switches |
| ② Radiator cap | ⑨ Front brake lever |
| ③ Rear brake lever | ⑩ Throttle grip |
| ④ Left handle switches | ⑪ Coolant reservoir tank cap |
| ⑤ Rear brake fluid reservoir | ⑫ Ignition switch |
| ⑥ Instrument panel | ⑬ Front storage box |
| ⑦ Front brake fluid reservoir | |

N O T E

“-----” : means the invisible parts.

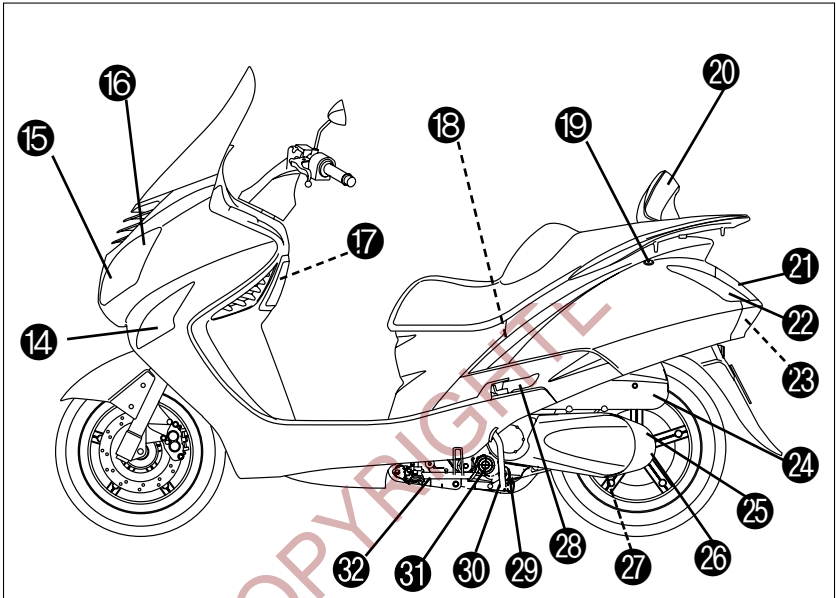

- ⑭ Turn signal lamp (Front)
- ⑮ Head lamp (High beam)
- ⑯ Head lamp (Position lamp)
- ⑰ Output terminal
- ⑱ Personal trunk
- ⑲ Seat lock
- ⑳ Passenger backrest
- ㉑ Brake / Tail lamp
- ㉒ Turn signal lamp (Rear)
- ㉓ License plate lamp

- ㉔ Air cleaner
- ㉕ Transmission oil filler cap
- ㉖ Transmission oil level bolt
- ㉗ Transmission oil drain bolt
- ㉘ Passenger footrests
- ㉙ Engine oil drain plug
- ㉚ Center stand
- ㉛ Engine oil filter
- ㉜ Side stand

NOTE

“-----” : means the invisible parts.

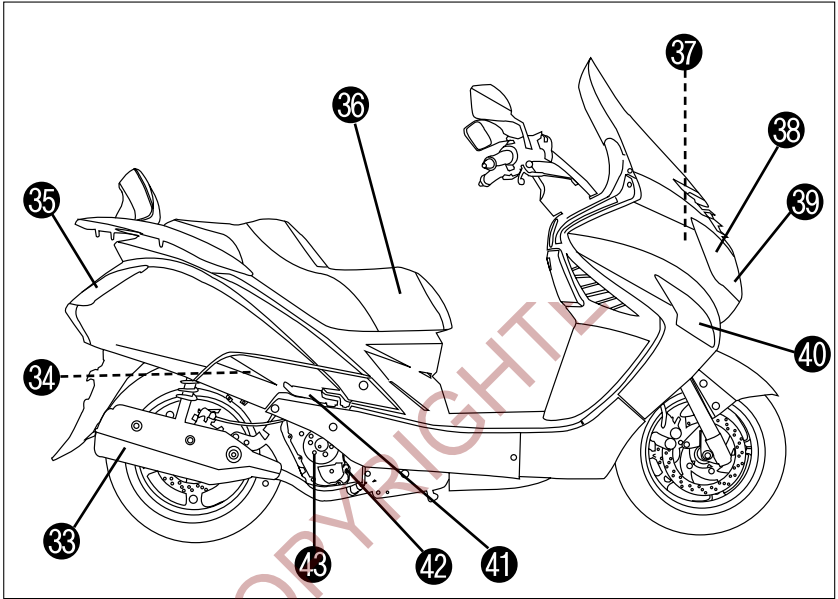

- ③③ Muffler
- ③④ Battery & Fuses
- ③⑤ Turn signal lamp (Rear)
- ③⑥ Seat
- ③⑦ Radiator
- ③⑧ Head lamp (Position lamp)

- ③⑨ Head lamp (Low beam)
- ④① Turn signal lamp (Front)
- ④② Passenger footrests
- ④③ Water pump
- ④④ Engine oil level gauge

NOTE

“ - - - - ” : means the invisible parts.

CONTROLS

IGNITION SWITCH

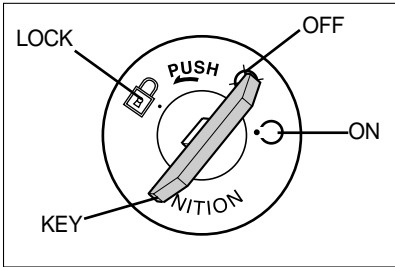

The ignition switch has three positions :

⊙ “⊗” (OFF) POSITION

All electrical circuits are cut off.
The engine will not start.
The key can be removed.

⊙ “●” (ON) POSITION

The ignition circuit is completed and the engine can now start.
The key cannot be removed from the ignition switch in this position.

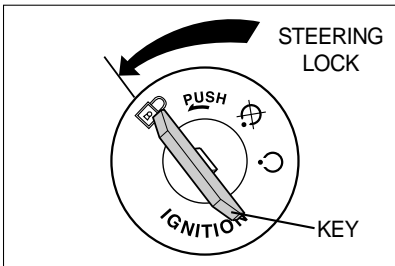

⊙ “🔒” (LOCK) POSITION

To lock the steering, turn the handlebar all the way to the left.

Turn the key to the “⊗” (OFF) position and push down it to the “🔒” (LOCK) position and remove the key.

All electrical circuits are disconnected.



WARNING

Turning the ignition switch to the “⊗” (OFF) or “🔒” (LOCK) position while the motorcycle is moving can be hazardous. Moving the motorcycle while the steering is locked can be hazardous. You could lose your balance and fall, or you could drop the motorcycle.

Stop the motorcycle and place it on the side stand if equipped before locking the steering. Never attempt to move the motorcycle when the steering is locked.

IGNITION KEY

These motorcycles come equipped with two ignition keys.

Keep the spare key in a safe place.

Key number :

INSTRUMENT PANEL

① 『MS3 250』

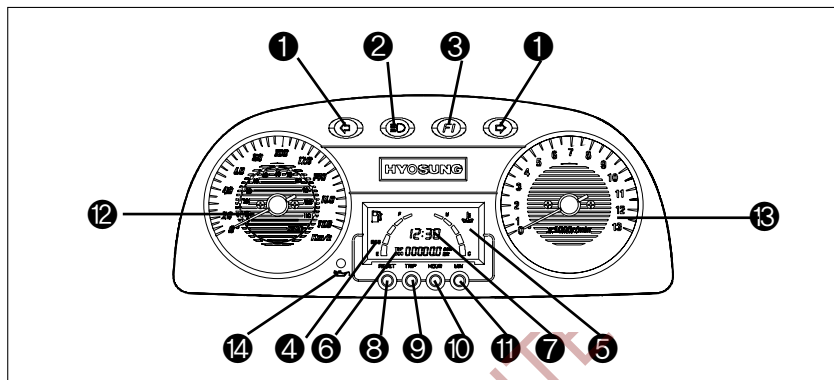

① 『MS3 125』

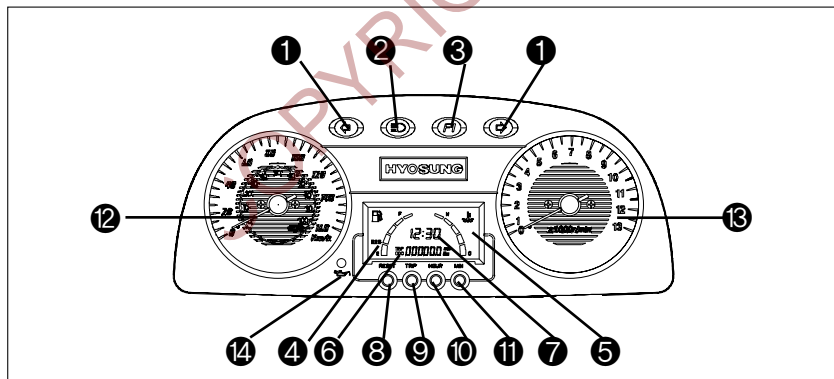

⚠ CAUTION

When the ignition switch is turned to the “”(ON) position, the display of speedometer will come on.

⚠ CAUTION

To adjust the light of speedometer display, push the switch ⑪ (in the clock mode) for 0.6 ~ 1 seconds while you want to change.

[Light of speedometer display]



① TURN SIGNAL INDICATOR LAMP

When the turn signals are being operated either to the right or to the left, the indicator will flash at the same time.

② HIGH BEAM INDICATOR LAMP

The high beam indicator lamp will come on when the head lamp high beam is turned on.

③ “FI”(Fuel Injection) CHECK LAMP

It comes on for about three seconds whenever the ignition switch is set to “”(ON) position with the engine stopped as a test of injection system operation. The check lamp must go off after three seconds.

⚠ CAUTION

If the lamp comes on during normal engine operation, it means that the fuel injection system is not operating correctly. When this is the case, stop the engine immediately and contact a Hyosung authorised dealer.

④ FUEL METER

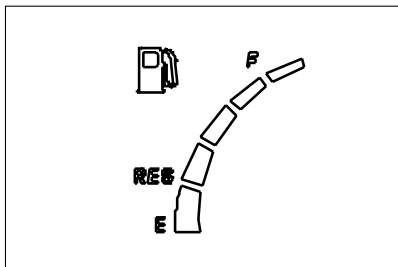

『MSB 650 / 125』's speedometer is LCD(Liquid Crystal Display) type, it indicates the remaining fuel amount in the fuel tank.

The “F”(Full) mark indicates the fuel tank is full.

The “E”(Empty) mark indicates the fuel tank is empty or nearly so.

When the remaining fuel is approximately 1.5ℓ, the 1st lower segment and “” mark flicker.

Fill the fuel tank before the lowest segment flickers.

The fuel tank capacity is 8.0ℓ.

⚠ CAUTION

When the lowest segment flickers, you should add fuel to the fuel tank at the first opportunity to avoid running out of fuel.

⚠ CAUTION

For checking the fuel meter, hold the motorcycle vertically and turn the ignition switch to the “”(ON) position.

⑤ COOLANT TEMPERATURE METER

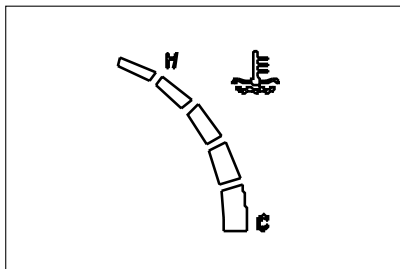

『MSB 350 / 350』's speedometer is LCD(Liquid Crystal Display) type, it indicates the coolant temperature.

The "H"(Hot) mark indicates the coolant temperature is hot.

When the coolant temperature is higher than 125°C, the coolant temperature meter displays all 5 segments.

The only lowest segment flickers when the coolant temperature is cool.

⚠ CAUTION

Running the engine with high engine coolant temperature can cause serious engine damage.

If the engine coolant temperature meter displays all 5 segments, stop the engine to let it cool.

Do not run the engine until the only lowest segment flickers.

⑥ ODOMETER / TRIP METER

The display in it has two functions, odometer and trip meter.

The display changes odometer or trip meter, as indicated before turning the ignition switch off.

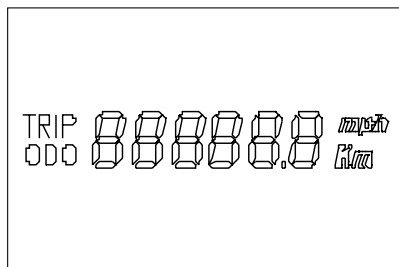

The odometer registers the total distance that the motorcycle has been ridden.

The trip meter is resettable odometer.

To change the display, push the switch ⑨ for 0.6 ~ 1 seconds while the display indicates the odometer or trip meter you want to change.

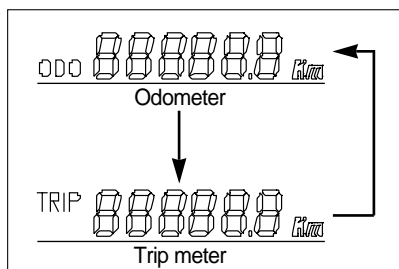

To reset the trip meter to zero, push the switch ⑧ (in the trip meter mode) for 0.6 ~ 1 seconds.

The odometer and trip meter changes a kilometer mode or mile mode.

To change the mode, push the switch ⑧

CLOCK ADJUSTMENT

Mode	Switch	Push it for	Adjustment
Clock	HOUR(ⓐ)	2 seconds	Clock mode → Clock reset mode
Clock reset mode	HOUR(ⓐ)	0.6 ~ 1 seconds	Increase the hour of clock
	MIN(ⓑ)	0.6 ~ 1 seconds	Increase the minutes of clock
	HOUR(ⓐ)	2 seconds	Clock reset mode → Clock mode

for 8 seconds while the display indicates a kilometer mode or mile mode you want to change.

⚠ WARNING

Operating the display while riding can be hazardous. Removing a hand from the handlebars can reduce your ability to control the motorcycle.

Always keep both hands on the handlebars while riding.

1. Push the switch ⓐ (in the clock mode) for 2 seconds until the hour and minutes display blink. It is the clock reset mode.
2. Adjust the hour display by pushing the switch ⓐ (in the clock reset mode) for 0.6 ~ 1 seconds.
3. Adjust the minutes display by pushing the switch ⓑ (in the clock reset mode) for 0.6 ~ 1 seconds.
4. Push the switch ⓐ (in the clock reset mode) for 2 seconds to resume in the clock mode.

⑦ CLOCK

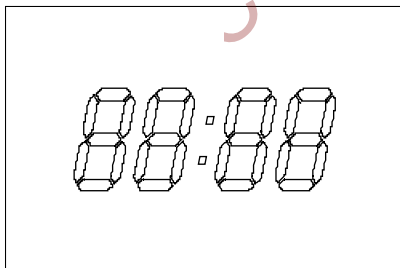

The clock indicates 24-hour mode.

Follow the procedure below to adjust the clock.

⑧ RESET SWITCH

Use this switch to adjust the following :

Push it for	Adjustment
8 seconds	Kilometer mode → Mile mode → Kilometer mode (Odometer & Trip meter)

● In the trip meter mode

Push it for	Adjustment
0.6 ~ 1 seconds	To reset the trip meter to zero

⑨ TRIP SWITCH

Use this switch to adjust the following :

Push it for	Adjustment
0.6 ~ 1 seconds	Odometer → Trip meter → Odometer

⑩ HOUR SWITCH

Use this switch to adjust the following :

● In the clock mode

Push it for	Adjustment
2 seconds	Clock mode → Clock reset mode

● In the clock reset mode

Push it for	Adjustment
0.6 ~ 1 seconds	Increase the hour of clock
2 seconds	Clock reset mode → Clock mode

⑪ MIN SWITCH

Use this switch to adjust the following :

● In the clock mode

Push it for	Adjustment
0.6 ~ 1 seconds	To adjust the light of speedometer display (100%→75%→50%→25%→100%)

● In the clock reset mode

Push it for	Adjustment
0.6 ~ 1 seconds	Increase the minutes of clock

⑫ SPEEDOMETER

The speedometer indicates the road speed in kilometers or miles per hour.

 **WARNING**

Obey the speed limit and traffic regulation at all times.

⑬ TACHOMETER

The tachometer indicates the engine speed in revolutions per minutes (rpm).

 **CAUTION**

Revving the engine into the red zone can cause severe engine damage.

Never allow the engine to rev into the red zone.

⑭ OIL PRESSURE INDICATOR LAMP

This indicator lamp comes on when the engine oil pressure is below the normal operating range.

This indicator lamp should come on when the ignition switch is “”(ON) and the engine is not running.

As soon as the engine starts, this lamp should go out.

 **CAUTION**

Riding the motorcycle with the oil pressure indicator lamp lit can damage the engine and transmission.

Whenever the oil pressure indicator lamp comes up, indicating low oil pressure, stop the engine immediately. Check the oil level and determine if the proper amount of oil is in the engine.

If the lamp still does not go out, have your authorized HYOSUNG dealer or qualified mechanic troubleshoot your motorcycle.

LEFT HANDLE SWITCHES

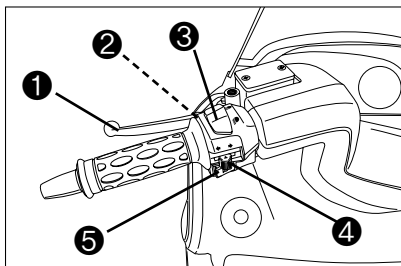

① REAR BRAKE LEVER

The rear brake is applied by squeezing the brake lever gently toward the handle grip.

Rear brake be anxious about motorcycle falling down when braking suddenly as drum brake system. The brake lamp will come on when the lever is squeezed.

WARNING

Apply the brake lightly and with great care on slippery surfaces to avoid skidding.

② “PASS” SWITCH

Press the “PASS” switch to operate the head lamp high beam for using when pass.

CAUTION

Not operate when the dimmer switch “” position

③ DIMMER SWITCH

Change the direction of head lamp light.

- “” : The head lamp high beam come on only.
The high beam indicator lamp also comes on.

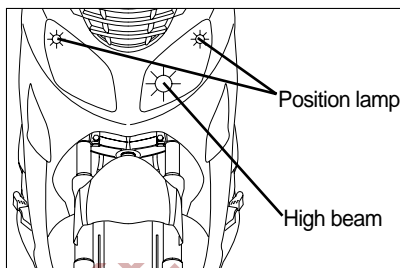

- “” : The head lamp low beam come on only.

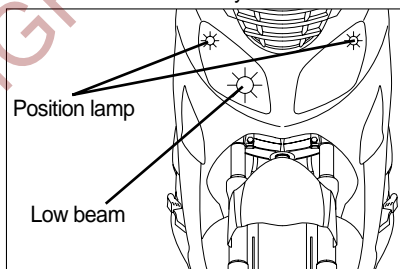

WARNING

Set the dimmer switch “” when other vehicle is running in front or against.

④ TURN SIGNAL SWITCH

Using when left, right turn or change direction.

- “↶” Position : Flash the left turn signal lamp.
- “↷” Position : Flash the right turn signal lamp.

⚠ CAUTION

Failure to use the turn signals, and failure to turn off the turn signals can be hazardous. Other drivers may misjudge your course and this may result in an accident.

Always use the turn signals when you intend to change lanes or make a turn. Always be sure to turn the turn signal switch to the “OFF” position after completing the turn or lane change.

⑤ HORN SWITCH

Press the switch to operate the horn.

RIGHT HANDLE SWITCHES

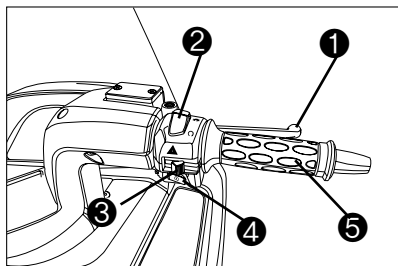

① FRONT BRAKE LEVER

The front brake is applied by squeezing the brake lever gently toward the throttle grip.

Front brake be anxious about motorcycle falling down when braking suddenly as disk brake system. The brake lamp will come on when the lever is squeezed.

⚠ WARNING

Apply the brake lightly and with great care on slippery surfaces to avoid skidding.

② ENGINE STOP SWITCH

- “⊗” Position : Using when dangerous condition of falling down during drive and others or engine stop suddenly. The ignition circuit is off. The engine cannot start or run.
- “○” Position : Using when need operation of engine as drive and others. The ignition circuit is on and the engine can run.

WARNING

Do not operate for the engine stop switch is in the "⊗" position while driving at one's pleasure.

③ HAZARD WARNING SWITCH

- "▲" : All four turn signal lamp and indicator lamp will flash simultaneously when the switch is turned on.
- "●" : The turn signal lamp and indicator lamp go off.

Use the hazard warning switch to warn other traffic during emergency parking or when your motorcycle could otherwise become a traffic hazard.

④ STARTER SWITCH

Use this switch to operate the starting motor.

CAUTION

With the engine stop switch in the "○" position and the ignition switch in the "○" (ON) position, push the starter switch to start the engine after go off the "FI" check lamp.

NOTE

If the front or rear brake lever is not squeezed, the starting motor will not rotate.

CAUTION

Do not engage the starting motor for more than five seconds at a time as it may overheat the wiring harness and starting motor.

If the engine does not start after several attempts, check the fuel supply and ignition system.
(Refer for Page 80)

CAUTION

These motorcycles always come on the head lamp, position lamp, meter lamp, tail lamp and license plate lamp when the ignition switch is turned to the "○" (ON) position.

⑤ THROTTLE GRIP

Engine speed is controlled by position of the throttle grip. Turn it toward you to increase engine speed. Turn it away from you to decrease the engine speed.

WARNING

Avoid turning the throttle grip during brakes.

STAND

These motorcycles is equipped with a center stand and side stand.

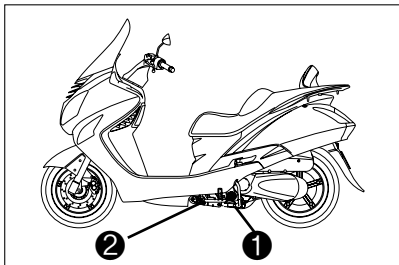

① CENTER STAND

To place the motorcycle on the center stand, place your foot on the stand extension and then rock the motorcycle to the rear and upward with the rear carrier with your right hand, while steadying the handlebars with your left hand.

② SIDE STAND

WARNING

Riding with the side stand incompletely retracted can result in an accident when you turn left.

Always retract the side stand completely before starting off.

CAUTION

Park the motorcycle on firm, level ground to help prevent it from falling over.

For better security, place the motorcycle on the center stand.

HOW TO USE

HOW TO OPEN THE SEAT

You can use the PERSONAL TRUNK after opening the seat.

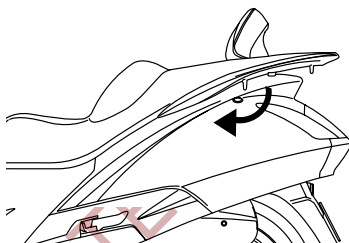

- 1) To unlock the seat, insert the ignition key into the seat lock and turn it clockwise.
- 2) To lock the seat, push down firmly until the seat latch snaps into the locked position.

WARNING

Before leaving, make sure that the seat is properly locked.

HOW TO USE THE PERSONAL TRUNK

Keep the owner's manual or maintenance manual in the personal trunk.

Put the helmet as shown in the picture.

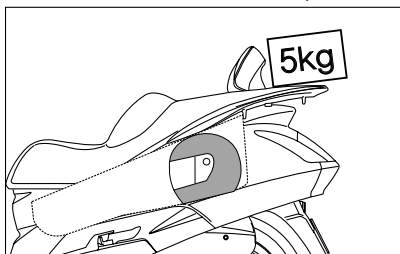

CAUTION

- The trunk could be heated. Don't keep anything that doesn't endure heat.
- Don't keep the fragile.
- Check if it is locked.
The unlocking of seat could cause serious accident.
- Don't allow water to get inside the trunk or it could damage.
- Don't wash the trunk with water. Use the vacuum cleaner.
- Don't keep the valuables in the trunk when leaving unattended.
- Exceed loading limit may result in injury caused by damage to the vehicle or altered handling characteristics.

NOTE

- Loading limit of personal trunk : 10 kg (22.1 lbs)
- Loading limit of rear carrier : 5 kg (11.0 lbs)

HOW TO OPEN THE FRONT STORAGE BOX

These motorcycles is equipped with a front storage box.

The front storage box can accommodate objects when you leave your bike unattended.

To open the storage box :

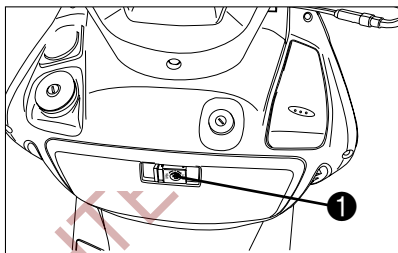

1. Insert the key in the lock①.
2. Turn the key counter-clockwise.
3. Press the latch button.

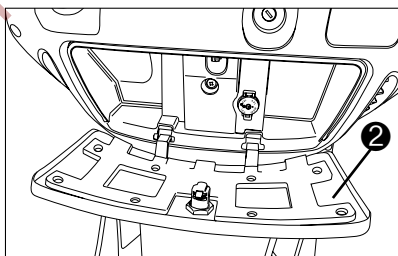

4. Open the front storage box cover②.

To lock the front storage box, push the lid firmly until the latch snaps into the locked position.

NOTE

- *Loading limit of front storage box : 1.5 kg (3.3 lbs)*
- *Front storage box is not a water-proof box so take out all valuables when washing the motorcycle.*

CAUTION

Avoid putting bulky objects disturbing smooth closing of the box lid, or it will cause deformation of the lid and water leakage into the box.

WARNING

Opening the box lid while riding can be hazardous.

Removing a hand from the handlebars can reduce your ability to control the motorcycle.

Always keep both hands on the handlebars during operation.

HOW TO USE THE OUTPUT TERMINAL

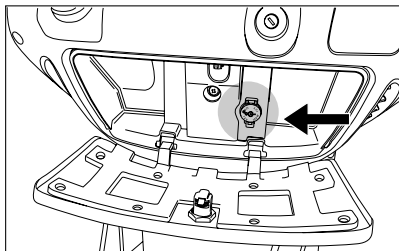

These motorcycles have an output terminal for attaching 12V electrical accessories.

The output terminal is located inside the front storage box.

Total electrical accessory wattage should be less than 120W.

It can be used to recharge small appliances rated up to 120W (mobile phone, inspection lamp, etc.).

Check electrical accessory voltage and wattage before attaching accessories to the output terminal.

CAUTION

Using improper electrical accessories can damage your motorcycle.

Exceeding 120W or using other than 12V accessory can seriously damage the electrical system and accessory.

Check voltage and wattage before connecting electrical accessories.

⚠ CAUTION

Prolonged use of the output terminal with the engine stopped may compromise the battery charge.

N O T E

The front storage box's lid may not latch closed if a long type plug is inserted into the output terminal.

SUPPLY OF GASOLINE, OIL AND COOLANT

GASOLINE

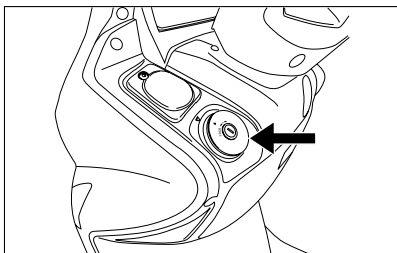

Insert the key and turn it clockwise to open the fuel tank cap with the key still held in a position, lift up on the key and remove the cap.

To install the fuel tank cap, the triangle mark of fuel tank cap face the triangle mark of frame cover and line up the fuel tank cap guide pins. Push down the fuel tank cap until the locking pins click into position. The key must be in the cap lock before installing the cap.

⚠ WARNING

- When refueling, always shut the engine off and turn the ignition key to the “” (OFF) position. Never refuel near an open flame.
- Do not overfill the fuel tank. Stop adding fuel when the fuel level reaches the bottom of the filler neck. If you fill the tank beyond this level, fuel may overflow when it expands due to engine heat or heating by the sun.



WARNING

Gasoline is extremely flammable and toxic. Always observe the following precautions when refueling your motorcycle.

- Never permit motorcycle refueling by anyone other than an adult.
- Refuel in a well ventilated area.
- Make sure the engine is off and avoid spilling fuel on a hot engine.
- Do not smoke, and make sure there are no open flames or sparks in the area.
- Avoid prolonged contact with skin and breathing of gasoline vapors.
- Keep children and pets away during refueling.

ENGINE OIL

Long engine life depends much on the selection of quality oil and the periodic changing of the oil.

Daily oil level checks and periodic changes are two of the most important maintenances to be performed.

⊙ ENGINE OIL LEVEL CHECK

Follow the procedure below to inspect the engine oil level.

1. Start the engine and run it for a few minutes.
2. Stop the engine and wait three minutes.



WARNING

The engine and the components of the exhaust system become very hot and remain hot for some time after the engine has been stopped. Before handling these components, wear insulating gloves or wait until the engine and the exhaust system have cooled down.

3. Hold the motorcycle vertically.

NOTE

Position the motorcycle on firm and flat ground.

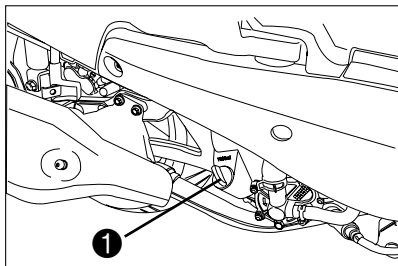

- Unscrew and extract the engine oil level gauge①.
- Clean the part in contact with the engine oil with a clean cloth.
- Reinsert the engine oil level gauge until the threads touch filler neck, but do not screw the engine oil level gauge in.

NOTE

Engine oil expands and oil level increases when the engine oil is hot. Check and adjust engine oil level when the engine oil is not hot.

- Draw out the engine oil level gauge and check the engine oil level. The level found on the engine oil level gauge should be between “Lower limit line” and “Upper limit line”.

If the engine oil level is below the “Lower limit line”, add fresh oil into the filler hole until the engine oil level reaches the “Upper limit line”.

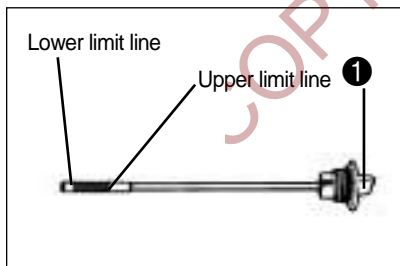

⚠ CAUTION

“Fuel, Oil and Coolant” use certainly to recommend at the front part.

⚠ CAUTION

Operating the motorcycle with an incorrect amount of engine oil can damage your motorcycle.

Too little or too much engine oil can damage your engine.

Place the motorcycle on level ground. Check the engine oil level with the engine oil level gauge before each use of the motorcycle. Be sure the engine oil level is always above the “Lower limit line” and not higher than the “Upper limit line”.

⊙ ENGINE OIL AND FILTER CHANGE

Change the engine oil and filter, after first running 1,000 km and every running 4,000 km.

The engine oil should always be changed when the engine is hot so that the engine oil will be drained thoroughly from the engine. The procedure is as follows.

ENGINE OIL CAPACITY		
	<i>MSA 650</i>	<i>MSA 125</i>
Replace	800 ml	←
Oil filter replace	900 ml	←
Overhaul	1,000 ml	←

⚠ CAUTION

In case of the engine oil pouring excessively, the engine output being made insufficient.

Be careful not to pour the engine oil excessively.

1. Hold the motorcycle vertically.

⚠ CAUTION

More frequent servicing may be performed on motorcycles that are used under severe conditions, inspect ① Quantity of Engine oil, ② Pollution degree of Engine oil before riding the motorcycle and then supplement and replace at any time to prevent damage of the engine.

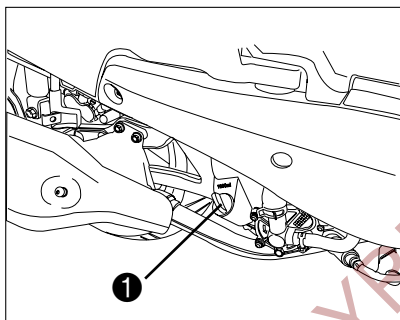

2. Remove the engine oil level gauge ①.

3. Place a drain pan under the engine.

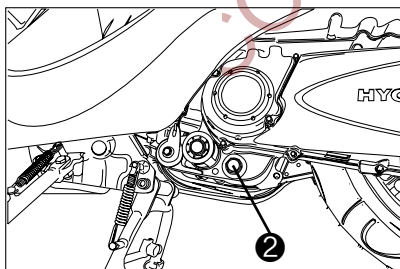

4. Drain the engine oil by removing the drain plug ② located on the left down-side of the engine.

⚠ CAUTION

Necessarily, confirm and clean the engine oil strainer ③ when replace the Engine oil (specially, when first replacement).

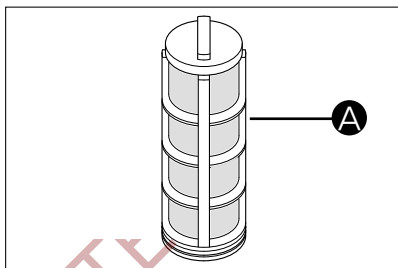

WARNING

New and used oil can be hazardous.

Children and pets may be harmed by swallowing new or used oil.

Continuous contact with used engine oil has been found to cause skin cancer in laboratory animals. Brief contact with used oil may irritate skin.

Keep new and used oil and used oil filters away from children and pets. To minimize your exposure to used oil, wear a long-sleeve shirt and moisture-proof gloves (such as dishwashing gloves) when changing oil. If oil contacts your skin, wash thoroughly with soap and water. Launder any clothing or rags if wet with oil. Recycle or properly dispose of used oil and filters.

WARNING

- The engine oil temperature may be high enough to burn you when the drain plug is loosened. Wait until the drain plug is cool enough to touch with bare hands before draining oil.
- Do not touch the hot muffler, or the hot muffler can burn you.

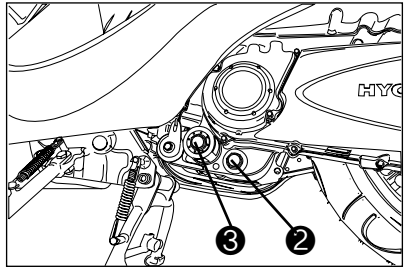

5. Reinstall the engine oil drain plug ② securely, but do not overtighten them.
6. Loosen the engine oil filter ③ counter-clockwise and remove it with a filter wrench of proper size.
7. Wipe off the mounting surface on the engine where the new engine oil filter will be seated with a clean rag.

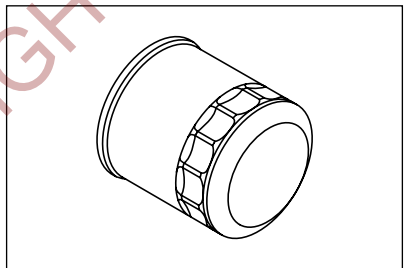

8. Smear a little engine oil around the rubber gasket of the new engine oil filter.

CAUTION

When replacing the engine oil filter, it is highly recommended that you use a genuine HYOSUNG oil filter designed for your motorcycle, as other filters may have different design and thread specifications which could cause engine damage or oil leaks.

9. Screw on the new engine oil filter by hand until the filter gasket contacts the mounting surface (a small resistance will be felt).

⚠ CAUTION

To tighten the engine oil filter properly, it is important to accurately identify the position at which the oil filter gasket first contacts the mounting surface.

10. Pour fresh engine oil through the filler hole. Approximately 900 ml of engine oil will be required.

NOTE

Approximately 800 ml of engine oil will be required when changing oil only without replacing the oil filter.

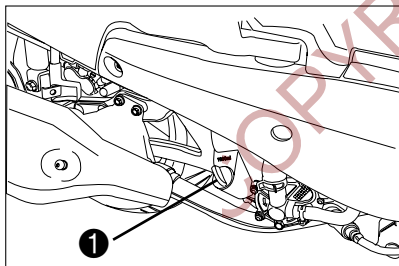

11. Install the engine oil level gauge①.

⚠ CAUTION

Failure to use the correct oil can damage your motorcycle.

Engine damage may occur if you use oil that does not meet Hyosung's specifications.

Be sure to use the oil specified in the FUEL, OIL AND COOLANT RECOMMENDATION section.

12. Start the engine and allow it idle for a few minutes. Check to see that no oil is leaking from the oil filter and drain plugs.
13. Check the oil level according to Oil Level Check procedure.

⚠ CAUTION

Oil leaks from around the oil filter or drain plugs indicate incorrect installation or gasket damage. If you find any leaks or are not sure that the oil filter has been properly tightened, have the motorcycle inspected by your Hyosung dealer or qualified mechanic.

TRANSMISSION OIL

After a long period of use, the transmission oil qualities will deteriorate and quicken the wear of sliding and interlocking surfaces.

⊙ TRANSMISSION OIL LEVEL CHECK

Inspect the transmission oil, after first running 1,000 km and every running 8,000 km.

Follow the procedure below to inspect the transmission oil level.

1. Hold the motorcycle vertically.

NOTE

Position the vehicle on firm and flat ground.



WARNING

The engine and the components of the exhaust system become very hot and remain hot for some time after the engine has been stopped. Before handling these components, wear insulating gloves or wait until the engine and the exhaust system have cooled down.

2. Stop the engine.

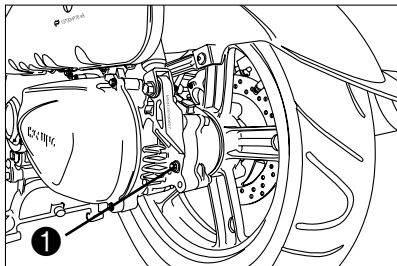

3. Remove the transmission oil level bolt (1).

4. Check the transmission oil level through the transmission oil level bolt.

The level found should be the lower end of the transmission oil level bolt hole.

If the transmission oil level is insufficient, add fresh transmission oil until the oil level reaches the transmission oil level bolt hole.

If the transmission oil is polluted, change the new transmission oil.



WARNING

Do not use the motorcycle with insufficient lubrication or with contaminated or unsuitable lubricants, since this would cause early wear of the moving parts and may also cause irreparable failures.

⊙ TRANSMISSION OIL CHANGE

1. Start the engine to warm up the oil, this will facilitate draining oil.
2. Hold the motorcycle vertically.

NOTE

Position the vehicle on firm and flat ground.

3. Place a drain pan under the engine.

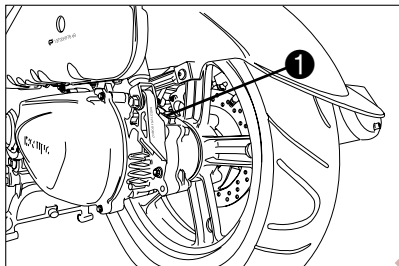

4. Remove the transmission oil filler cap (1).

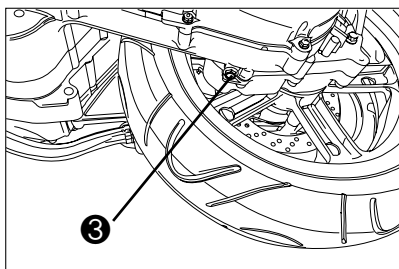
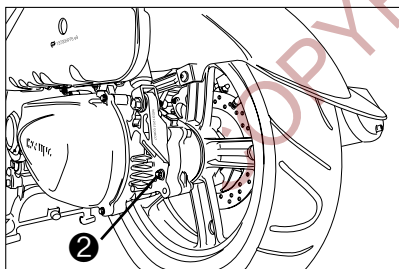

5. Release and remove the transmission oil level bolt (2) and oil drain bolt (3).
6. Let all transmission oil drain out. Collect it in a drain pan with adequate capacity.
7. Fit and tighten the transmission oil drain bolt (3).
8. Fill about 360ml of the specified oil through the transmission oil filler hole.

TRANSMISSION OIL CAPACITY

	MS3 650	MS3 657
CHANGE	360 ml	←
OVERHAUL	400 ml	←

9. Install the transmission oil filler cap (1).
10. Check the transmission oil level using the transmission oil level bolt hole and top up as required without exceeding the transmission oil level bolt hole.
11. Install the transmission oil level bolt (2).
12. Operate the engine a few minutes by idling speed.
Inspect the oil leakage at the transmission oil drain bolt and oil level bolt.

ENGINE COOLANT

⊙ COOLANT LEVEL

The coolant should be kept between the "F" (FULL) and "L" (LOW) level lines in the reservoir tank at all times. Inspect the level every time before riding while the motorcycle vertically through the front frame cover.

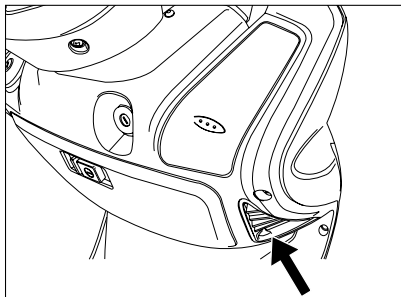

If the coolant is found lower than the "L" level line, add properly mixed coolant in the following way :

If the reservoir tank is emptied, pour the engine coolant to the reservoir tank and radiator.

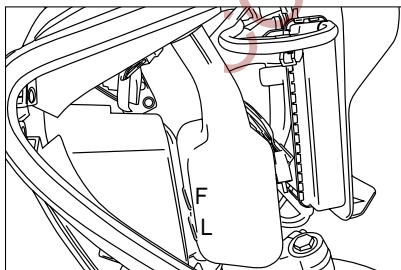

WARNING

Wait for the engine to cool down before checking or topping up coolant level.

1. Stop the engine and wait until it has cooled down.

NOTE

Position the motorcycle on firm and flat ground.

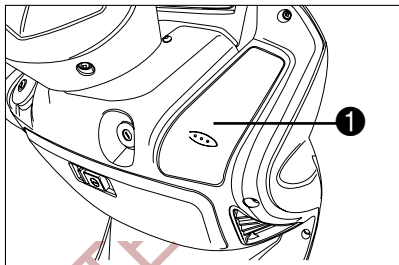

2. Open the coolant reservoir tank filler cap cover ① by lightly pressing.

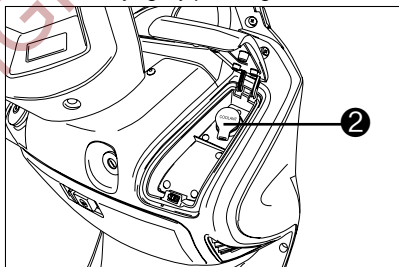

3. Remove the filler cap ② .
4. Add properly mixed coolant through the filler hole until it reaches the "F" line.

Refer to the FUEL, OIL AND COOLANT RECOMMENDATION section (13 page).

⚠ CAUTION

Never top up beyond the "F" line or coolant will leak out when the engine is running.

5. Install the filler cap.

⚠ CAUTION

If coolant level drops too quickly or the reservoir tank is empty, check the cooling circuit for leaks. Have the repair carried out at an authorized Hyosung dealer.

6. Shut the coolant reservoir tank filler cap cover, ensure it is correctly secured.

⚠ WARNING

Engine coolant is harmful or fatal if swallowed or inhaled.

Do not drink anti-freeze or coolant solution. If swallowed, do induce vomiting. Immediately contact a poison control center or a physician. Avoid inhaling mist or hot vapors ; if inhaled, remove to fresh air.

If coolant gets in eyes, flush eyes with water and seek medical attention. Wash thoroughly after handling. Solution can be poisonous to animals. Keep out of the reach of children and animals.

N O T E

Adding only water will dilute the engine coolant and reduce its effectiveness. Add 50 : 50 mixture of engine coolant and water.

⊙ CHANGING THE COOLANT

Change the coolant every two years.

N O T E

About 1.2 ℓ of coolant will be required when filling the radiator and reservoir tank.

⊙ OPEN THE RADIATOR CAP

Remove the radiator cap cover ① to operate the radiator cap ③ .

To disassemble the radiator cap cover ① , remove the mounting bolt ② .

⚠ WARNING

You can be injured by scalding fluid or steam if you open the radiator cap when the engine is hot.

After the engine cools, wrap a thick cloth around cap and carefully remove the cap by turning it a quarter to allow pressure to escape and then turn the cap all the way off.

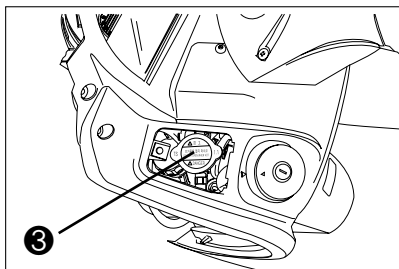
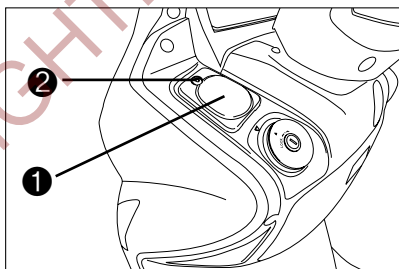

THE PROPER OPERATIONS

STARTING THE ENGINE

Before riding

- Check how much the engine oil and gasoline is left.
- Put the motorcycle on the center stand.

⚠ CAUTION

Inspect every day once before riding the motorcycle.

⚠ CAUTION

These motorcycles always come on the head lamp, position lamp, meter lamp, tail lamp and license plate lamp when the ignition switch is turned to the “”(ON) position.

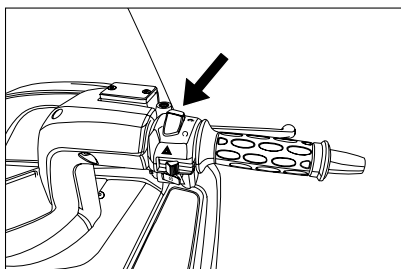

- ① The engine stop switch is in the “” position.

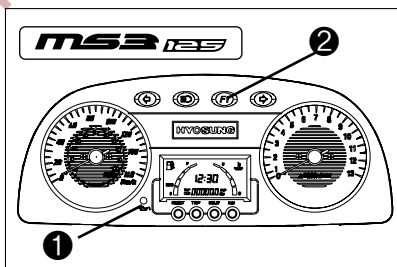
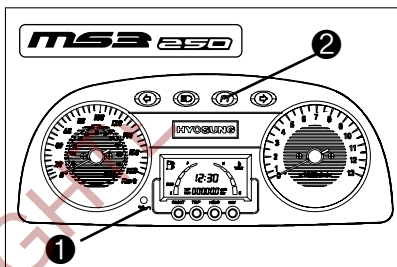
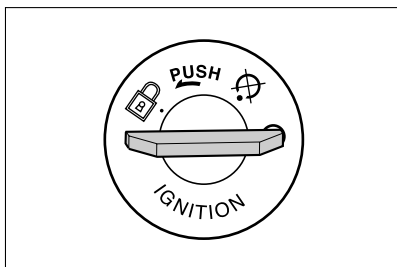

- ② Set the ignition switch “”(ON).



⚠ CAUTION

The following happens :
the engine oil pressure indicator lamp “” ① and “FI” check lamp “” ② on the instrument panel should come on. These lamps should go out as soon as you start the engine.
If these lamps does not come on when the ignition switch is set to

“”(ON) position or fails to go out after the engine start, contact an authorized Hyoung dealer.

③ Squeeze the rear brake lever.

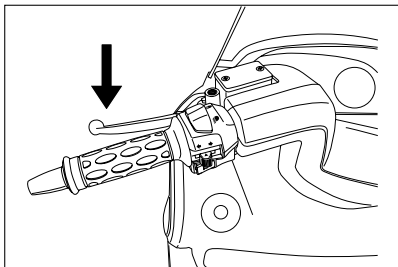

CAUTION

If the front or rear brake lever is not squeezed, the starting motor will not rotate.

④ Push the starter switch without turning the throttle grip after go off the “FI” check lamp.

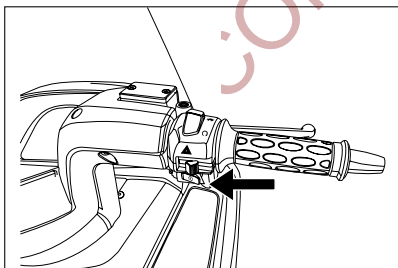

CAUTION

- Take off the starter switch right after started.
- Do not engage the starting motor for more than five seconds at a time as it may overheat the wiring harness and starting motor. If the engine does not start after several attempts, check the fuel supply and ignition system. (Refer for Page 80)

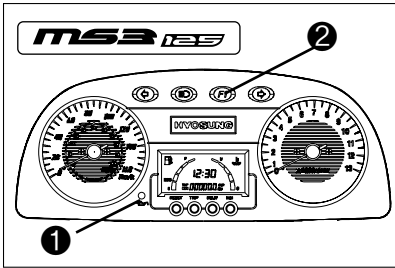
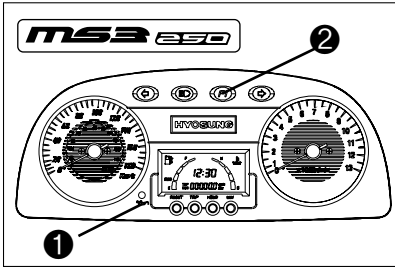

- Keep at least one brake operated and do not accelerate until you are ready to move off.
- When it doesn't start after several trial, turn the throttle grip to $\frac{1}{8}$ ~ $\frac{1}{4}$ position.

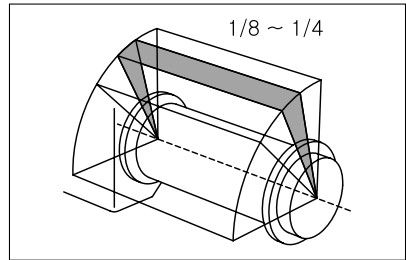

⚠ CAUTION

As soon as the engine has started, the engine oil pressure indicator lamp “” ① and “FI” check lamp “” ② must go out. If these lamps stays on or comes on during normal operation, it means that oil pressure in the circuit is too low or the fuel injection system is not operating correctly. Stop the engine immediately and contact an authorized Hyosung dealer. Do not use the motorcycle with insufficient engine oil or disabled fuel injection system, in order to avoid damaging the engine components.

⚠ CAUTION

Avoid pressing the starter switch when the engine is running, or starting motor damage.

⚠ CAUTION

When started, return the throttle grip.

⚠ WARNING

Running the engine indoors or in a garage can be hazardous. Exhaust gas contains carbon monoxide, a gas that is colorless and odorless and can cause death or severe injury. Only run the engine outdoors where there is a fresh air.

⚠ CAUTION

Running the engine too long without riding may cause the engine to overheat. Overheating can result in damage to internal engine components and discoloration of exhaust pipes. Shut the engine off if you cannot begin your ride promptly.

- It is not started easily in the cases as follows.

- 1) It has been long since you started the motorcycle.
- 2) There was no gasoline left.

In this case(1, 2), push the starter switch longer without turning the throttle grip.

- 5 When the engine is cold, idle it for a while.



WARNING

- Don't idle it indoor where there is little or no ventilation available.
- The exhaust gas including carbon monoxide is extremely poisonous.

STARTING OFF

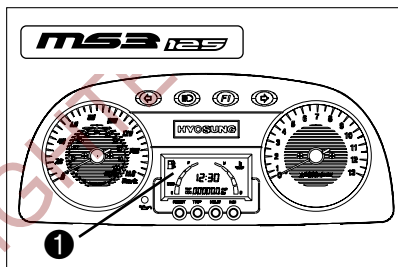
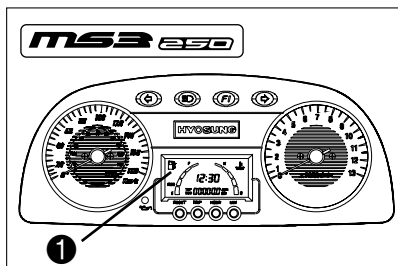

CAUTION

If the 1st lower segment and “” mark ① positioned on the dashboard flicker while the motorcycle running, this means that there are still 1.5 ℓ of fuel available.

Refuel as soon as possible, see page 31.



WARNING

If you are riding with a passenger, give your passenger proper instructions to avoid problems when maneuvering.

1 Return the center stand.

For returning the center stand, push the motorcycle forward gripping the rear brake lever with left hand and the rear carrier with right hand.

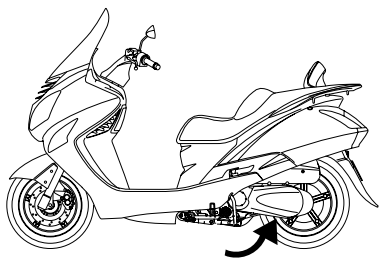

CAUTION

When returning the center stand, grip the rear carrier.

2 Ride on

Gripping the brake lever with both hands, seat on from left side of the motorcycle.

Put the left foot on the earth and fasten the rear brake lever.

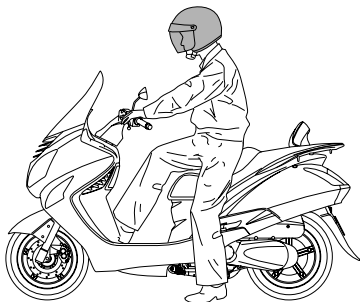

CAUTION

Don't let the engine run excessively before riding.

3 Adjust the rear-view mirrors

WARNING

With the motorcycle stopped, try to familiarise with the use of the mirrors. Convex mirrors provide a large view, but any objects seen in these mirrors seem farther than they really are. It may take some time to learn to judge the distance of traffic behind accurately.

4 Check the safety

Turn on the left turn signal lamp and check the safety.

Grip up the rear brake lever.

WARNING

Be careful of the vehicles in back.

5 Start off

Take off the rear brake lever and turn the throttle grip slowly, the motorcycle will start moving forward.

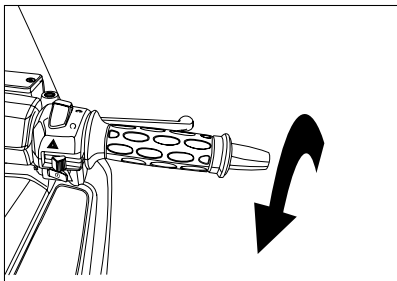

CAUTION

Never start off abruptly with cold engine.

To reduce emissions and fuel consumption, ride slowly until covering several kilometers to warm the engine up to operating temperature.

WARNING

Riding these motorcycles at excessive speed increases your chances of losing control of the motorcycle.

This may result in an accident.

Always ride within the limits of your skills, your motorcycle, and the riding conditions.

WARNING

Removing your hands from the handlebars or feet from the footrests during operation can be hazardous. If you remove even one hand or foot from the motorcycle, you can reduce your ability to control the motorcycle. Always keep both hands on the handlebars and both feet on the footrests of your motorcycle during operation.

WARNING

Sudden side winds, which can occur when being passed by large vehicles, at tunnel exits or in hilly areas, can upset your control.

Reduce your speed and be alert to side winds.

WARNING

When turned the throttle grip excessively, it will make quick start which is dangerous.

WARNING

Do not operate the ignition switch of its "⊗"(OFF) or "🔒"(LOCK) position or the engine stop switch of its "⊗" position while driving at one's pleasure.

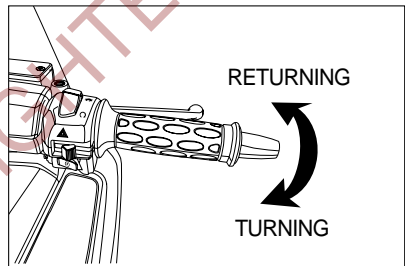

You can adjust the speeds with the throttle grip.

- TURNING - - - - Get faster
- RETURNING - - - - Get slower

OPERATING THE BRAKE

Apply the front and rear brakes at the same time.

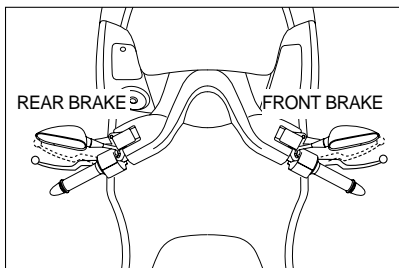

- Grip the brake lever right after returning the throttle grip.
- Make the speed lower by operating the brake slowly.

WARNING

Using either front or rear brake is dangerous and can cause skidding and loss of control.

WARNING

When approaching a turn, slow down or brake and take the turn at moderate, constant speed or accelerate slightly : braking in a turn will greatly increase your chances of skidding. Continued application of the brakes on long downhill grades may cause the brakes to overheat, thereby reducing brake efficiency. Never ride downhill with engine off!

WARNING

When you need to brake, close the throttle and use both brakes for smooth braking : take care to apply the right amount of pressure to both brakes.

Using one brake only gives less braking power and you could lock a wheel and lose grip.

To stop uphill, decelerate completely and use the brakes to keep the motorcycle at standstill.

- ⊙ The quick brake can cause skidding.

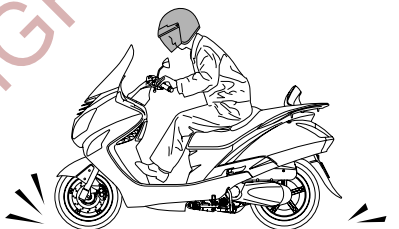

⊙ Pay much more attention to driving when rains or snows.

- When the brake doesn't work normally, keep low speeds and apply the brake lightly until smoothly operated.

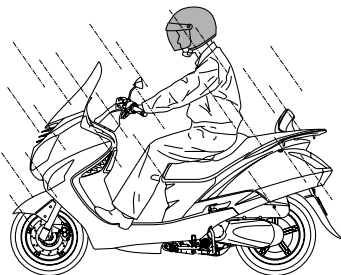

⚠ WARNING

If the road surface is wet or slippery (snow, ice, mud, etc.), ride slowly, do not brake or swerve suddenly, or you may lose grip and fall.

Watch out for obstacles or sudden changes in the road surface.

Uneven roads, rails, manhole covers, indications painted on the road surface, building site metal plates become rather slippery by rain.

For this reason all these obstacles have to be carefully avoided, driving smoothly and bending the motorcycle as little as possible.

⚠ WARNING

Signal your intention to change lane or turn in good time using the direction indicators and avoid sudden swerving or movements.

Switch off the direction indicators as soon as you have finished turning. Be extremely careful when overtaking or being overtaken.

When riding in the rain, the spray thrown up by the tires of large vehicles will reduce your vision ; the air wave created by a large vehicle may make you lose control of the motorcycle.

STOPPING AND PARKING

WARNING

If you can, do not stop or slow down suddenly and avoid limit-braking.

- 1 Release the throttle grip and gradually put on the brakes to stop the motorcycle.
- 2 If you need to stop only briefly, keep at least one brake applied.

WARNING

Park the vehicle on firm and level ground, to prevent it from falling. Do not lean the vehicle against a wall, or lay it on the ground. Make sure that the vehicle, and in particular hot motorcycle components, may not put the safety of persons and children at risk. Do not leave the motorcycle unattended with the engine running or the key in the ignition switch. Do not sit on the vehicle when the stand is down.

- 3 Turn on the turn signal lamp and return the throttle grip.
- 4 When completely stopped, turn off the turn signal lamp. Set the key “” (OFF) position.
Park the motorcycle on a firm, flat surface where it will not fall over.

CAUTION

With the engine stopped and the ignition switch in “” (ON) position, the battery may run flat.

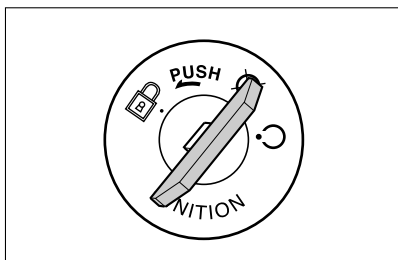

- 5 Put the motorcycle on the center stand.

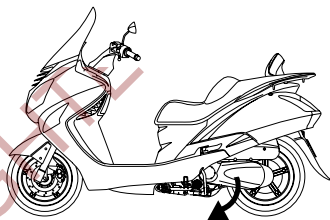

CAUTION

Don't park the motorcycle on the slippery or tilted surface. Make sure that the motorcycle is stable.

WARNING

Hard braking while turning may cause wheel skid and loss of control.

Brake before you begin to turn.



WARNING

Hard braking on wet, loose, rough, or other slippery surfaces can cause wheel skid and loss of control.

Brake lightly and carefully on slippery or irregular surfaces.



WARNING

Following another vehicle too closely can lead to a collision. As vehicle speeds increase, stopping distance increases progressively.

Be sure you have a safe stopping distance between you and the vehicle in front of you.

- ⑥ Lock the steering for security.
- ⑦ Pull the ignition key out of the lock and keep it yourself.



CAUTION

Never leave the key in the ignition switch.



WARNING

A hot muffler can burn you. The muffler will be hot enough to burn you for some time after stopping the engine.

Park the motorcycle where pedestrians or children are not likely to touch the muffler.

BREAK-IN

The opening explains how important proper break-in is to achieve maximum life and performance from your new **Hyosung**. The following guidelines explain proper break-in procedures.

★ MAXIMUM THROTTLE OPENING RECOMMENDATIONS

The table below shows the maximum throttle opening recommendation during the break-in period.

Initial 800km (500miles)	Less than 1/2 throttle
Up to 1,600km (1,000miles)	Less than 3/4 throttle

★ AVOID CONSTANT LOW SPEED

Operating the engine at constant low speed(light load) can cause parts to glaze and not seat in. Allow the engine to accelerate freely through the gears, without exceeding the recommended maximum limits. Do not, however, use full throttle for the first 1,600km (1,000 miles).

★ VARY THE ENGINE SPEED

The engine speed should be varied and not held at a constant speed.

This allows the parts to be "loaded" with pressure and then unloaded, allowing the parts to cool.

This aids the mating process of the parts.

It is essential that some stress be placed on the engine components during break-in to ensure this mating process.

Do not, though, apply excessive load on the engine.

★ BREAKING IN THE NEW TIRES

New tires need proper break-in to assure maximum performance, just as the engine does.

Wear in the tread surface by gradually increasing your cornering lean angles over the first 160km (100miles) before attempting maximum performance. Avoid hard acceleration, hard cornering, and hard braking for the first 160km (100miles).



WARNING

Failure to perform break-in of the tires could cause tire slip and loss of control. Use extra care when riding on new tire. Perform proper break-in of the tire as described in this section and avoid hard acceleration, hard cornering, and hard braking for the first 160km (100miles).

★ ALLOW THE ENGINE OIL TO CIRCULATE BEFORE RIDING

Allow sufficient idling time after warm or cold engine start up before applying load or revving the engine. This allows time for the lubricating oil to reach all critical engine components.

★ OBSERVE YOUR FIRST, AND MOST 1,000km SERVICE

The 1,000km (600miles) service is the most important service your motorcycle will receive.

During break-in procedures, all of the engine components will have worn in and all of the other parts will have seated in.

All adjustments will be restored, all fasteners will be tightened, and the dirty engine oil will be replaced.

Timely performance of the 1,000km (600miles) service will ensure optimum service life and performance from the engine.

CAUTION

Service should may be performed before 1,000km (600miles) on motorcycle that are used under severe conditions.

CAUTION

The 1,000km (600miles) service should be performed as outlined in the PERIODIC MAINTENANCE section of this Owner's Manual. Pay particular attention to the 「CAUTION」 and 「WARNING」 in that section.

INSPECTION BEFORE RIDING

WARNING

Failure to inspect the motorcycle before operating it can be hazardous. Failure to perform proper maintenance can also be hazardous.

Failure to inspect and maintain your motorcycle increases the chances of an accident or equipment damage.

Always inspect your motorcycle each time you use it to make sure it is in safe operating condition. Refer to the INSPECTION AND MAINTENANCE section in this owner's manual.

WARNING

Operating these motorcycles with improper tires, or with improper or uneven tire pressure can be hazardous.

If you use improper tires or improper or uneven tire pressure, you may lose control of the motorcycle. This will increase your risk of an accident.

Always use the size and type tires specified in this owner's manual. Always maintain proper tire pressure as described in the INSPECTION AND MAINTENANCE section.

WARNING

Operating these motorcycles with improper modifications can be hazardous.

Improper installation of accessories or modification of these motorcycles may cause changes in handling. In some situations, this could lead to an accident.

Never modify these motorcycles through improper installation or use of accessories.

WARNING

Overloading these motorcycles or carrying or towing cargo improperly can be hazardous.

Overloading or improper towing could cause changes in motorcycle handling which could lead to an accident.

Never exceed the stated load capacity for these motorcycles.

Check the condition of the motorcycle to help make sure that you do not have mechanical problems, or you might get stranded somewhere when you ride. Before riding the motorcycle, be sure to check the following items. Be sure your motorcycle is in good condition for the personal safety of the rider and protection of the motorcycle.

WARNING

Checking maintenance items when the engine is running can be hazardous.

You could be severely injured if your hands or clothing gets caught in moving engine parts.

Shut the engine off when performing maintenance checks, except when checking the lamp, engine stop switch and throttle.

WHAT TO CHECK	CHECK FOR :
Steering	<ul style="list-style-type: none">• Smoothness• No restriction of movement• No play or looseness
Throttle	<ul style="list-style-type: none">• Proper cable play• Smooth response• Quick return to idle position
Brakes	<ul style="list-style-type: none">• Fluid level in the reservoir to be above "LOWER" line• Correct brake lever play• No "sponginess"• No fluid leakage• Brake pads not to be worn down to the limit line• Proper operation
Suspension	Smooth movement
Fuel	<ul style="list-style-type: none">• Enough fuel for the intended run• Fuel hoses connected securely• No damage to fuel tank or cap• Tank cap closed securely
Tires	<ul style="list-style-type: none">• Proper pressure• Enough tread depth• No cracks, rips, or other damage

Engine oil	<ul style="list-style-type: none"> • Correct level and pollution degree of engine oil • No engine oil leakage
Transmission oil	No transmission oil leakage
Lamp	Operation of all lamps and indicators
Horn	Correct function
Rear-view mirror & Reflector	No dust or damage
Engine stop switch	Correct function
Cooling system	<ul style="list-style-type: none"> • Proper coolant level • No coolant leaks or damage
General condition	<ul style="list-style-type: none"> • Bolts and nuts are tightened • No rattle from any parts of the motorcycle with the engine running • No visible evidence of damage
Side stand & Center stand	Smooth operation

CAUTION

- The engine and muffler are too hot right after engine stopped, please be careful not to be burned.
- Don't inspect the engine indoor where there is little or no ventilation available. The exhaust gas is extremely poisonous.

PERIODIC MAINTENANCE

The chart indicates the intervals between periodic service in kilometers.

At the end of each interval, be sure to inspect, check, lubricate and service as instructed.

If your motorcycle is used under high stress conditions such as continuous full throttle operation, or is operated in a dusty climate, certain services should be performed more often to ensure reliability of the machine as explained in the maintenance section.

Your **Hyosung** dealer can provide you with further guide lines.

Steering components, suspensions require very special and careful servicing. For maximum safety we suggest that you have these items inspected and serviced by your authorized **Hyosung** dealer or a qualified service mechanic.



WARNING

Improper maintenance or failure to perform recommended maintenance increases the chance of an accident or motorcycle damage.

Always follow the inspection and maintenance recommendations and schedules in this owner's manual.

Ask your Hyosung dealer or a qualified mechanic to do the maintenance items marked with a pentagram(★).

You may perform the unmarked maintenance items by referring to the instructions in this section, if you have mechanical experience.

If you are not sure how to do any of the jobs, have your Hyosung dealer or a qualified mechanic do them.

WARNING

Running the engine indoors or in a garage can be hazardous.

Exhaust gas contains carbon monoxide, a gas that is colorless and odorless and can cause death or severe injury.

Only run the engine outdoors where there is fresh air.

CAUTION

Using poor quality replacement parts can cause your motorcycle to wear more quickly and may shorten its useful life.

Use only genuine Hyosung replacement parts or their equivalent.

NOTE

The MAINTENANCE CHART specifies the minimum requirements for maintenance. If you use your motorcycle under severe conditions, perform maintenance more often than shown in the chart. If you have any questions regarding maintenance intervals, consult your Hyosung dealer or a qualified mechanic.

LUBRICATION POINTS

Proper lubrication is important for smooth and long life of each working part of your motorcycle and also for safe riding. It is a good practice to lubricate the motorcycle after a long rough ride or after it gets wet in the rain or after washing it.

Major lubrication points are indicated as follows.

CAUTION

Lubricating switches can damage the switches.

Do not apply grease and oil to the switches.

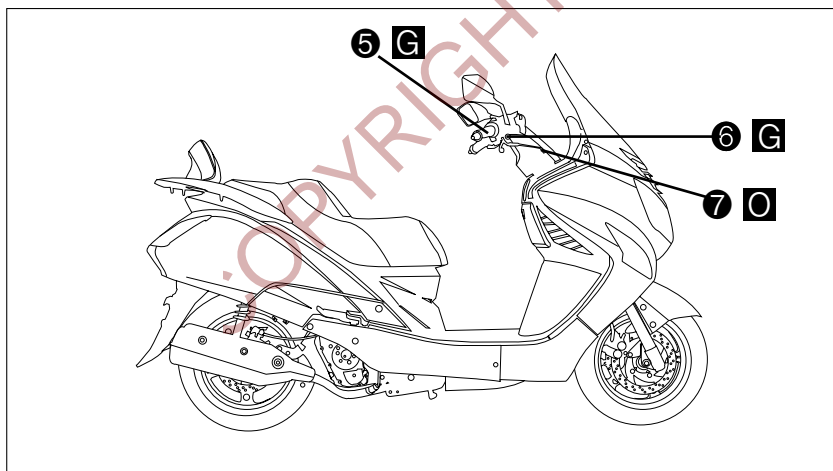
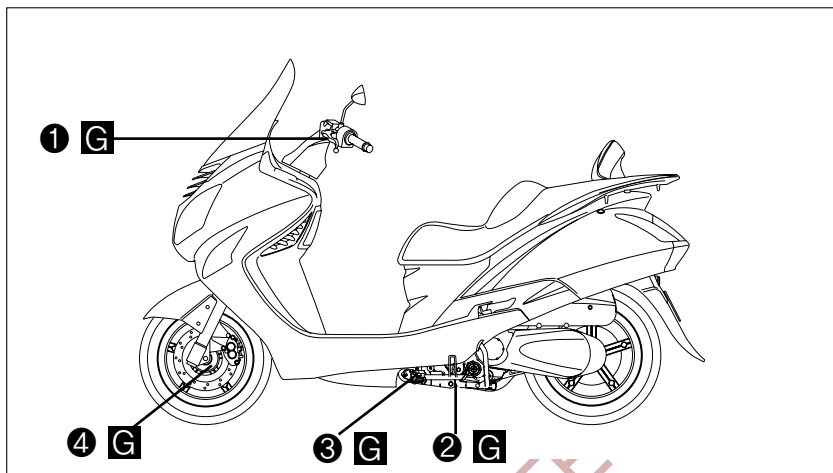

- ① Rear brake lever holder
- ② Center stand pivot and spring hook
- ③ Side stand pivot and spring hook
- ④ Speedometer gear box

- ⑤ Throttle grip
- ⑥ Front brake lever holder
- ⑦ Throttle cable

⓪ - Motor oil Ⓜ - Grease

● **ENGINE**

Item \ Interval	First 1,000 km	Every 4,000 km	Every 8,000 km
Air cleaner element	Clean every 3,000 km · Replace every 12,000 km		
Exhaust pipe nuts and muffler mounting bolts ★	Tighten	Tighten	—
Valve clearance adjust ★	Inspect	Inspect	—
Cylinder head bolt ★	Tighten	Tighten	—
Spark plug	Clean	Clean	Replace
Fuel hose	Inspect	Inspect	—
	Replace every 4 years		
Engine oil filter	Replace	Replace	—
Engine oil	Replace	Replace	—
Throttle cable	Inspect	Inspect	—
Idle speed ★	Inspect	Inspect	—
Engine coolant ★	Replace every 2 years		
Radiator hose ★	—	Inspect	—
	Replace every 4 years		
Transmission oil ★	Inspect	—	Inspect
Drive belt ★	—	—	Inspect

● **CHASSIS**

Item \ Interval	First 1,000 km	Every 4,000 km	Every 8,000 km
Brake ★	Inspect	Inspect	—
Brake hose ★	Inspect	Inspect	—
	Replace every 4 years		
Brake fluid ★	Inspect	Inspect	—
	Replace every 2 years		
Tire	Inspect	Inspect	—
Steering ★	Inspect	Inspect	—
Front forks ★	—	Inspect	—
Rear shock absorber ★	—	Inspect	—
Chassis nuts and bolts ★	Tighten	Tighten	—
General lubrication	Lubricate	Lubricate	—

N O T E

★ = Ask your Hyosung dealer or qualified mechanic to do the maintenance items marked.

INSPECTION AND MAINTENANCE

TOOL

To assist you in the performance of periodic maintenance, a tool kit is supplied and is located under the seat. The tool kit consists of the following items.

NO.	NAME
1	Tool bag
2	10 × 12 mm open end spanner
3	Spark plug wrench
4	Combination screw driver
5	Screw driver handle

ENGINE OIL

Check if there is leakage from the crankcase.

TRANSMISSION OIL

Check if the transmission oil leaks.

GASOLINE

Check if there is leakage from the fuel tank, fuel pump, hose and fuel injection system.

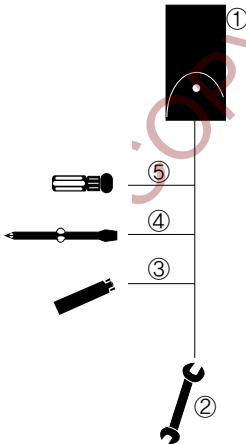

FUEL HOSE

Inspect the fuel hose for damage and fuel leakage. If any defect are found the fuel hose must be replaced.

Replace the fuel hose every 4 years.

COOLANT

Check if there is leakage from the radiator, coolant hose.

RADIATOR

Check if there is damage from the radiator.

RUBBER CAP OF CABLES

Mop them up with a patch when washing.

EXHAUST PIPE AND MUFFLER

Inspect the exhaust pipe and muffler joint for loosening.

REAR-VIEW MIRROR

Check if the mirror shows the rear and / or side views.

REFLECTOR

Check if the reflector is dusty or damaged.

BRAKES

These motorcycles utilize front and rear disk brakes.

The proper operation of the brake systems is vital to safe riding. Be sure to perform the brake inspection requirements as scheduled.

The brakes should be inspected at periodic inspection by your authorized Hyosung dealer.

If the front or rear brake lever play out of the specification, consult your authorized Hyosung dealer or a qualified service mechanic.

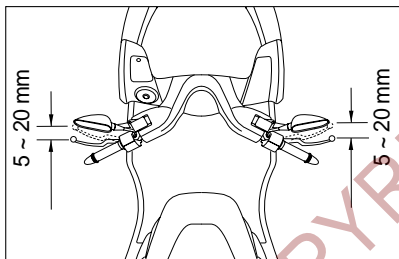

WARNING

Too much play in the front or rear brake lever can cause poor braking performance and may lead to an accident.

Too little play may force brake pads to rub against the disk at all times, causing damage to the pads and disk.

WARNING

Failure to properly inspect and maintain your motorcycle brake systems can be hazardous.

Improper maintenance of the brakes increases your chances of having an accident.

Be sure to inspect the brakes before each use of the motorcycle according to the **INSPECTION BEFORE RIDING** section. Always maintain your brakes according to the **MAINTENANCE SCHEDULE**.

WARNING

Operating the motorcycle in harsh condition can be hazardous if you do not inspect brake wear often.

Operating in mud, water, sand, or other extreme conditions can cause accelerated brake wear. This could lead to an accident.

If you operate your motorcycle under these conditions, the brakes must be inspected more often than recommended in the **MAINTENANCE SCHEDULE**.

⊙ BRAKE FLUID

Be sure to check the brake fluid level in the master cylinder. If the level was found to be lower than the lower mark holding the motorcycle upright, inspect the brake pad's wear condition.

As the brake pads wear, the fluid level will drop to compensate for the new position of brake pads.

If the brake pad's wear condition is good, replenish with the proper brake fluid that meets Hyosung's requirements.

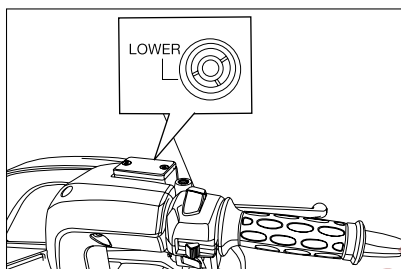

[Front Brake]

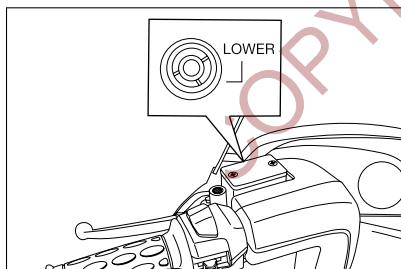

[Rear Brake]



WARNING

Brake fluid may be harmful if swallowed or if it comes in contact with skin or eyes. Contact your doctor immediately if brake fluid is swallowed and induce vomiting. If brake fluid gets into the eyes or in contact with the skin, flush thoroughly with plenty of water.



CAUTION

These motorcycles uses glycol-based brake fluid.

Do not use or mix different types of brake fluid, otherwise serious damage will result in the brake system.

Use DOT4 brake fluid for front and rear.

Do not spill any brake fluid on painted or plastic surfaces as it will damage the surface severely.

Never use any brake fluid that has been stored in a used or unsealed container. Never reuse brake fluid left over from the last servicing and stored for long period as it absorbs moisture from the air.

⊙ BRAKE PADS

Inspect the front and rear brake pads by nothing whether or not the friction pads are worn down to the grooved limit line. If a pad is worn to the grooved limit line it must be replaced with a new one by your authorized Hyosung dealer or qualified service mechanic.

The rate at which brake pads will wear depends on motorcycle usage, riding style and road surface condition.

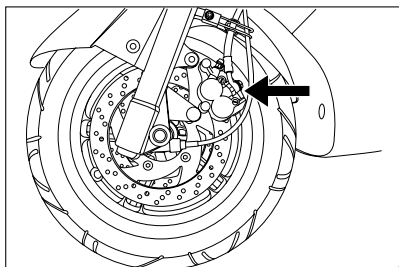

[Front Brake]

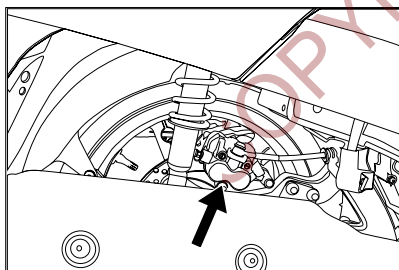

[Rear Brake]

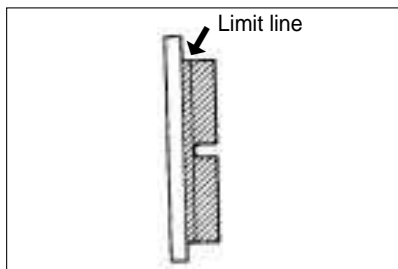

Inspect every day in the following point at the brake system.

- ① Brake fluid leakage of the front and rear brake system.
- ② Leak or damage of the brake hose.
- ③ Operating of the brake lever.
- ④ Wear of the front and rear brake pads.

⚠ CAUTION

The front and rear brake system be replaced the brake hose or the brake fluid according to periodic inspection chart by your authorized Hyosung dealer for safety as in times of operating at high pressure.

⚠ WARNING

Riding with worn brake pads will reduce braking performance and will increase your chance of having accident. Inspect brake pad wear before each use. Ask your Hyosung dealer or qualified mechanic to replace brake pads if any pad is worn to the limit.

WARNING

If brake pads were allowed to wear down until uncovering the metal substrate, metal-to-metal contact with the brake disc would lead to rattle and the brake caliper sparking ; this would result in loss of braking and brake disc damage, causing a dangerous riding conditions.

CAUTION

After replaced the front or rear brake pads, the brake lever pull and release several times so that it is setting at the original place.
Then, do not ride the motorcycle until operating the brake fluid and becoming the brake distance.

BRAKE DISK INSPECTION

Check the brake disk for damage or cracks.

FRONT & REAR BRAKE FLUID SUPPLY

1. Place the motorcycle on a level surface and keep the handlebars straight.
2. Clean the brake fluid reservoir around not to allow dust to get inside of it.
3. Loosen the screw and open the cap.
4. Replenish with brake fluid to the upper line.

CAUTION

Do not spill any brake fluid on painted or plastic surfaces as it will damage the surface severely.

N O T E

The recommended brake fluid

: DOT4

5. Fasten the cap.

CAUTION

- Don't replenish with brake fluid over the limit line. It will leak out of the brake fluid reservoir.
- Be careful not to allow dusts or water to go inside when it is replenished.
- Don't use the unrecommended brake fluid.
- Brake fluid can damage severely the plastics or rubbers. When it is spilled on the parts, mop them up.

⊙ FRONT & REAR BRAKE LAMP SWITCH

The front & rear brake lamp switch is located beneath the front & rear brake lever. Loosen the switch fitting screws and adjust the timing by moving the switch body forward or backward.

TIRES

Inspect the tire pressure and the tire thread depth periodically.

Inspect frequently the tire pressure for the safety and the tire life.



WARNING

Failure to follow these warnings may result in an accident due to tire failure. The tires on your motorcycle form the crucial link between your motorcycle and the road.

Follow these instructions ;

- Check tire condition and pressure, and adjust pressure before each ride.
- Avoid overloading your motorcycle.
- Replace a tire when worn to the specified limit, or if you find damage such as cuts or cracks.
- Always use the size and type of tires specified in this owner's manual.

⊙ TIRE PRESSURE

Insufficient air pressure in the tires not only hasten tire wear but also seriously affects the stability of the motorcycle.

Under-inflated tires make smooth cornering difficult and over-inflated tires decrease the amount of tire in contact with the ground which can lead to skids and loss of control. Be sure that the tire pressure is within the specified limits at all times.

Tire pressure should only be adjusted when the tire is cold.

If you see the problem with the tire, adjust the pressure with the pressure gauge.

TIRE PRESSURE (COLD INFLATION)	NORMAL RIDING	
	SOLO RIDING	DUAL RIDING
FRONT	1.75 kg/cm ²	1.75 kg/cm ²
	172 kpa	172 kpa
	25.0 psi	25.0 psi
REAR	2.00 kg/cm ²	2.50 kg/cm ²
	197 kpa	246 kpa
	29.0 psi	36.0 psi

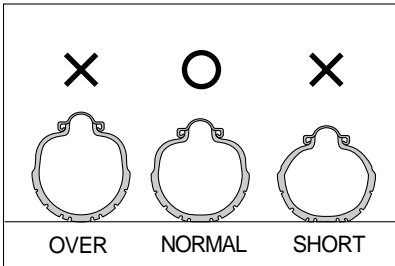

⚠ CAUTION

If there are some problem with the tire pressure or cracks and cuts, it will decrease the riding stability and lead to flat tire.

⊙ CRACKS AND CUTS

Check if

- 1) there are visible cracks and cuts.
- 2) there are abnormal wears.

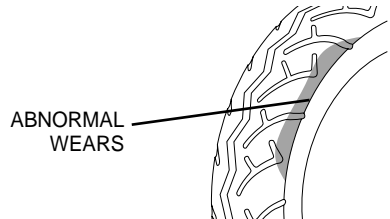
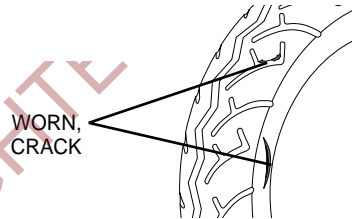
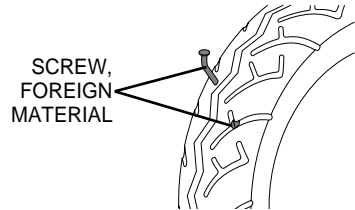

⊙ TIRE TREAD CONDITION

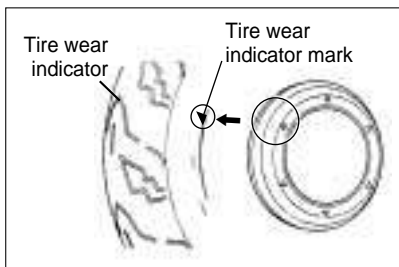

Operating the motorcycle with excessively worn tire will decrease riding stability and can lead to loss of control.

Inspect storage of tire thread's depth by the 「tire wear indicator」.

Replace the front and rear tires at once when appear the 「tire wear indicator」.

⚠ CAUTION

The standard tire on these motorcycle is 120/70-13M/C 53S for front and 140/60-14M/C 64S for rear.

The use of a tire other than standard may cause trouble.

It is highly recommended to use the standard tire supplied by Hyosung.

AIR CLEANER

The air cleaner is located on the beneath left side cover.

If the air cleaner element has become clogged with dust, intake resistance will increase with a resultant decrease in power output and an increase in fuel consumption. If riding under severe conditions must be cleaned or replaced more frequently than maintenance schedule. Check and clean the air cleaner element periodically according to the following procedure.

⚠ CAUTION

Never operate the engine without the element in position.

Operating the engine without the air cleaner element will increase engine wear. Always be sure that the air cleaner element is in excellent operational condition.

The life of the engine depends largely on this single component.

⚠ CAUTION

If the air cleaner element is polluted, will occur to starting go out, output insufficiency, combustion efficiency decline, and sooty smoke (black smoke).

This appearance is occurred at first to clean the air cleaner element and confirm.

1. Position the motorcycle on the center stand.

2. Lift the side cover. (Refer to page 70)

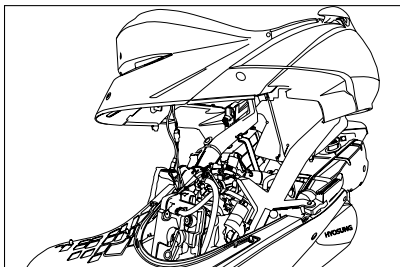

3. Unscrew and remove the eight screws
①.

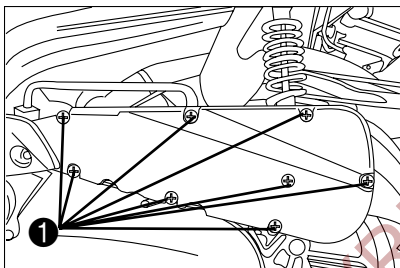

4. Remove the air cleaner case cover ②.
5. Take off the air cleaner element ③.

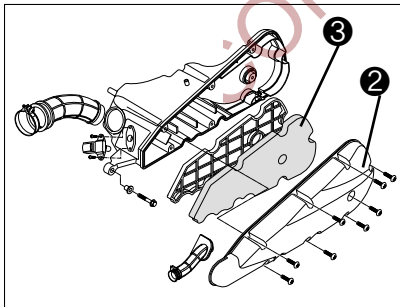

6. Fill a washing pan of a proper size with nonflammable cleaning solvent (A). Immerse the element in the cleaning solvent and wash it clean.

7. Squeeze the cleaning solvent out of the washed element by pressing it between the palms of both hands : do not twist or wring the element or it will develop tears.
8. Immerse the element in HYOSUNG genuine oil (B) and squeeze the oil out of the element leaving it slightly wet with oil.
9. Assemble the air cleaner element.

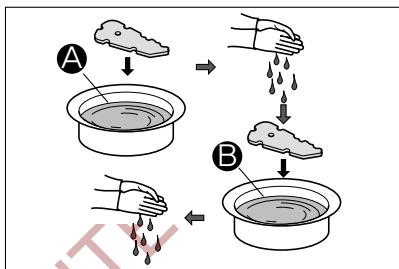

⚠ CAUTION

Before and during the cleaning operation, inspect the element for tears. A torn element must be replaced. Be sure position the element snugly and correctly, so that no incoming air will bypass it. Remember, rapid wear of piston rings and cylinder bore is often caused by a defective or poorly fitted element.

⚠ CAUTION

- Don't use the cleaning solvent whose flash point is low when cleaning the element.
- Assemble the element completely or damage severely the engine.
- Be careful not to allow water to go inside the air cleaner element.

⚠ CAUTION

- When the assembly of air cleaner element is not completely done, dusts can go inside and damage severely engine.
- Be careful not to allow water to go into the element while washing.

⚠ CAUTION

More frequent servicing may be performed on motorcycles that are used under severe conditions, also clean the air cleaner element to prevent damage of the engine.

FRONT AND REAR SUSPENSIONS

Periodically check for the following :

- Keep the front brake lever pulled in and push down on the handlebar repeatedly to compress the front fork.
- The fork should compress in a smooth movement and must show no traces of oil on the legs.
- Ensure that all components are properly tightened and check the front and rear suspension articulated joints for correct operation.

⚠ CAUTION

In the event of malfunction or if the suspension needs expert servicing, contact an authorised Hyosung dealer.

⊙ OIL RETURN TANK DRAIN PLUG

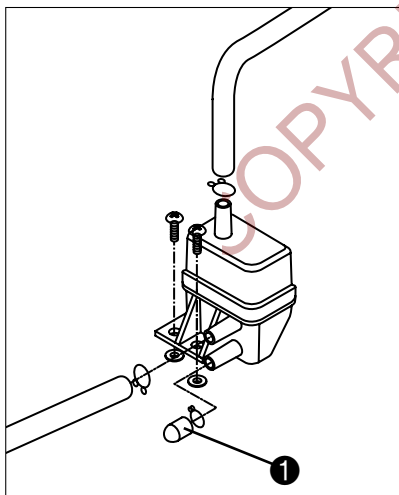

Inspect the plug ① and drain water and oil at the periodic interval.

The oil return tank drain plug ① is located the side of the oil return tank.

CHECKING THE STEERING

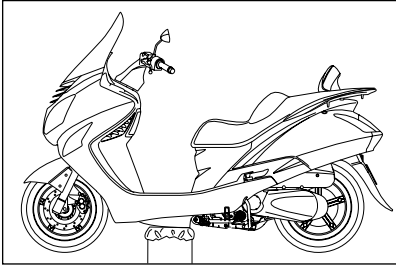

Occasionally check the steering slack.
Check as follows :

- Position the vehicle on the center stand.

NOTE

Provide a support of adequate height and width to support the vehicle safely.

- Place the support under the vehicle and a spongy cloth between them, so that the front wheel can move freely and the vehicle can not fall down.

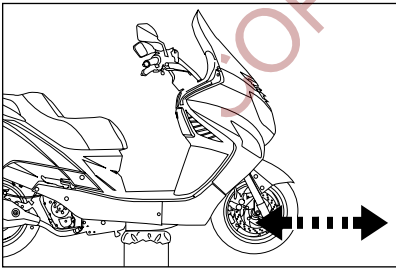

CAUTION

Make sure that the vehicle is stable.

- Shake the fork in the riding direction.

CAUTION

Do not shake the fork excessively, otherwise you may take in consideration the movement of the stand, thus observing an incorrect slack. Repeat the previous operation more than once.

- If you find that there is considerable slack, contact your authorised Hyosung dealer to restore the optimal steering conditions.

CHECKING THE ENGINE PIVOT

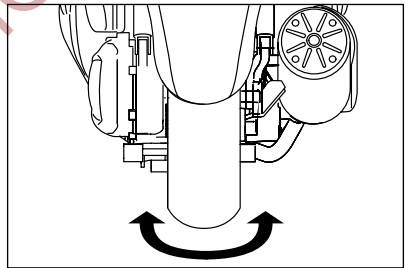

Periodically check the slack existing between the engine pivot bushings.

Check as follows :

- Position the vehicle on the center stand.
- Shake the wheel right and left with respect to the riding direction.
- If any slack should be noticed, contact your authorised Hyosung dealer, to restore the optimal operating conditions.

SIDE COVER STAY

『MSR 650/125』 have the "Side cover stay" inside the side cover.

Use the "Side cover stay" to inspect the engine or the other parts easily.

1. Position the motorcycle on the center stand.
2. Raise the seat.

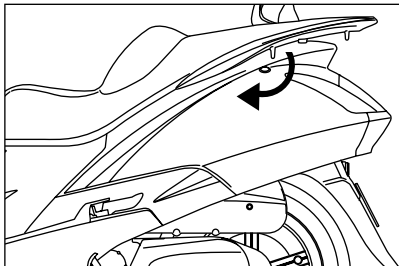

3. Remove the two bolts ① in the personal trunk.

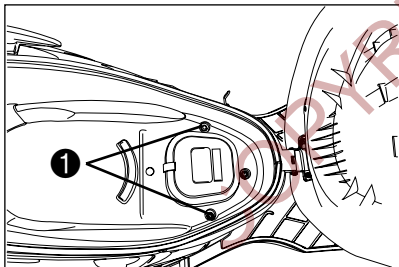

4. Remove the two bolts ② of the rear carrier.

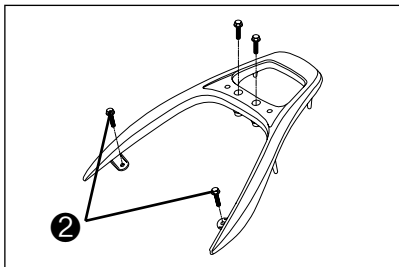

5. Push the side cover for the rear side.

CAUTION

Proceed with care.

Do not damage the cover, reflector and lamp.

Handle plastic and paint-finished parts with care to avoid scratching or damage.

6. Disconnect the tail lamp coupler.
7. Lift the front end of the side cover and prop it up as shown below.
Insert the crank end of the side cover stay ③ into the hole of the side cover.

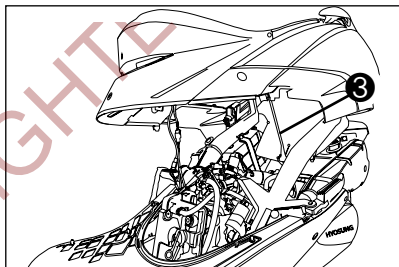

CAUTION

Upon reassembly, install the bolts and cover correctly in the appropriate seats.

HELMETBOX INNER COVER

『*ms3 650 / 125*』 have the “helmetbox inner cover” inside the personal trunk.

Use the “helmetbox inner cover” to inspect the fuel injection system easily.

1. Position the motorcycle on the center stand.
2. Raise the seat

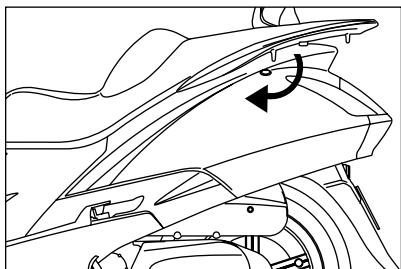

3. Lift the helmetbox inner cover knob ① carefully.

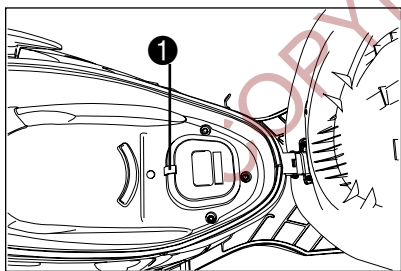

CAUTION

Proceed with care.
Do not damage the personal trunk and helmetbox inner cover.
Handle plastic parts with care to avoid damage.

PASSENGER BACKREST

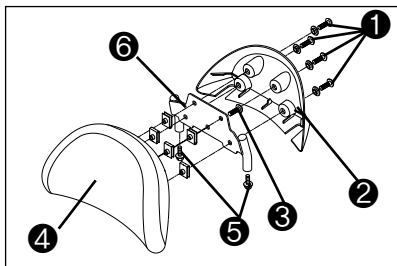

『*ms3 650 / 125*』 is equipped with the passenger backrest for passenger's safety and comfortableness.

To remove the passenger backrest :

1. Remove the four backrest cover mounting bolt ① .
2. Remove the backrest cover ② .
3. Remove the one backrest mounting bolt ③ .
4. Remove the backrest ④ .
5. Remove the two backrest bracket mounting bolt ⑤ .
6. Remove the backrest bracket ⑥ .

To install the passenger backrest, reverse the above sequence.

IDLING ADJUSTMENT

We suggest that you have 『*ms3 650 / 125*』's idling speed adjusted by your authorized Hyosung dealer.

CAUTION

Do not adjust the idle speed to avoid variations of the cabruration setting.

ADJUSTING THE THROTTLE CABLE

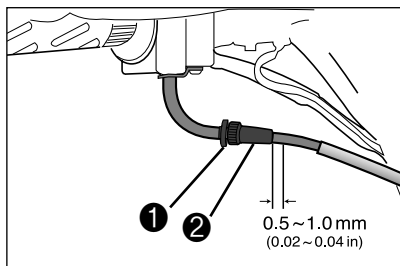

There should be 0.5 ~ 1.0 mm (0.02~0.04 in) free play in the throttle cable.

If this is not the case, proceed as follows :

- Position the motorcycle on the center stand.
- Withdraw the protection.
- Loosen the lock nut ① .
- Rotate the adjuster ② until achieving the specified free play.
- When finished, tighten the lock nut ① and check free play again.
- Refit the protection.

WARNING

Inadequate throttle cable play can cause engine speed to rise suddenly when you turn the throttle grip. This can lead to loss of rider control.

Adjust the throttle cable play so that engine idle speed does not rise due to throttle grip movement.

WARNING

When finished, turn the handlebar to make sure its movement does not affect the engine idle rpm and check that the throttle grip - when opened and then released - returns smoothly to the closed position.

SPARK PLUG

Check the spark plug every time a scheduled maintenance service is performed.

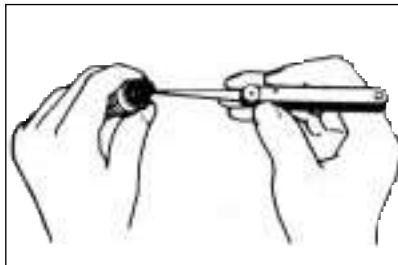

At regular intervals, remove the spark plug and clean off any carbon deposits or replace as required.

To reach the spark plug :

- Remove the helmetbox inner cover.

To remove and clean the spark plug :

WARNING

Before carrying out the following operations, let the engine and the muffler cool down to ambient temperature, in order to avoid burns.

1. Disconnect spark plug cap.
2. Remove all the dirt from the base of the spark plug, then unscrew it and extract it from its seat, taking care that neither dust nor other substances enter the cylinder.
3. Make sure that there are neither carbon deposits, nor corrosion marks on the electrode and on the central part : if necessary, clean them with the special cleaners for spark plugs, with an iron wire and / or a metal brush.
4. Energetically blow some air, in order to prevent the removed residues from get-

ting into the engine. Change the spark plug if it shows cracks on the insulating material, corroded electrodes or excessive deposits.

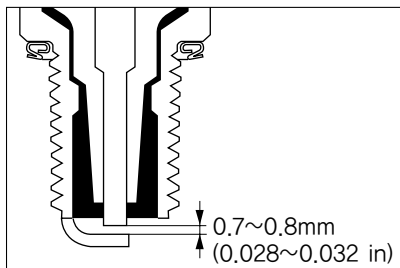

5. Check the electrode gap with a thickness gauge. The gap must be 0.7 ~ 0.8 mm (0.028 ~ 0.032 in) if necessary, adjust it.
6. Make sure that the washer is in good condition. Fit the washer and screw the spark plug finger-tight to avoid damaging the thread.
7. Tighten using the spanner supplied with the tool kit. Screw in each spark plug by one half turn to compress the washer.

TIGHTENING TORQUE

SPARK PLUG	11 N · m (1.1 kgf · m)
------------	------------------------

PLUG REPLACEMENT GUIDE

Hotter type	CR7E
Standard type	CR8E
Colder type	CR9E

⚠ CAUTION

The spark plug must be tightened firmly, otherwise the engine may overheat and severe damage may occur. Use recommended spark plugs only. A spark plug of the wrong rating may shorten engine life and cause loss of performance.

8. Fit the spark plug cap properly, to prevent it coming off due to engine vibration.
- 9 Refit the inspection cover.

BATTERY

⊙ INSPECTION OF BATTERY SOLUTION LEVEL

MF(Maintenance Free) battery of airtight type is used for these motorcycles.

It is not necessary to inspect or supplement battery fluid.

The battery is located inside the right side front lower cover.

However, have your dealer check the charging condition of battery periodically.

⚠ CAUTION

- Do not remove absolutely airtight cover as airtight type battery.
- Keep after separate at the motorcycle for the minimum of self electric discharge and electric leakage when don't use for a long time. Remove the (-) negative terminal when keep intact at the motorcycle.

⚠ WARNING

Never invert the battery cables. Ensure that the ignition switch is in position "⊗"(OFF) before connecting or disconnecting the battery, otherwise some components might damage.

⊙ REMOVING THE BATTERY

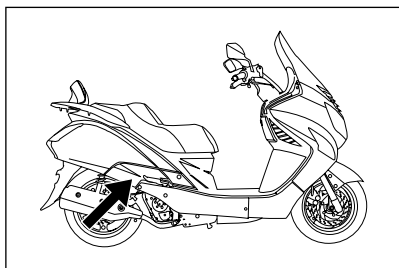

NOTE

Position the motorcycle on firm and flat ground.

1. Position the motorcycle on the center stand.
2. Make sure that the ignition switch is in position "⊗"(OFF).
3. Remove the screw ① and hexagon bolt ②.
4. Remove the right side front lower cover ③.

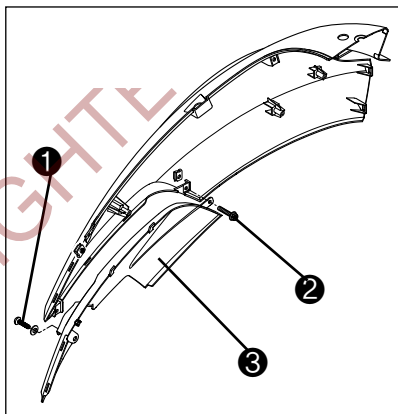

5. Disconnect the negative (-) battery wire first, then disconnect the positive (+) battery wire.
6. Remove the battery.

⊙ CHECK AND CLEAN OF BATTERY TERMINAL

Clean the battery terminal when it is dusty or rusted.

1. Set the ignition switch "⊗"(OFF) position.
2. Remove the right side front lower cover.
3. Check that battery lead wire and terminal.
4. If necessary : disconnect the negative (-) battery wire first, then disconnect the

positive (+) battery wire.

Remove the battery.

5. Clean the terminal.

If there is white dust, clean it with warm water.

6. Connect the battery wires and grease the terminal lightly.

When reinstalling the battery, be sure to connect the positive (+) battery wire first, then connect the negative (-) battery wire.

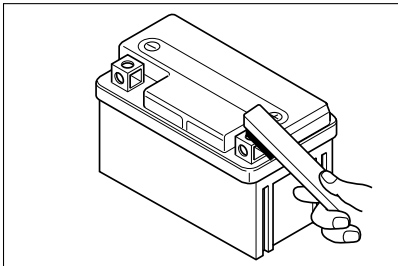

⊙ FUSE

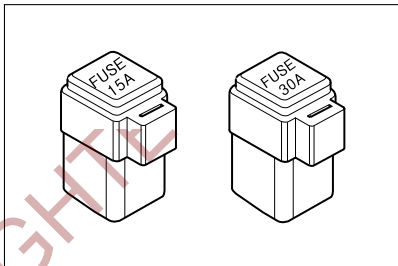
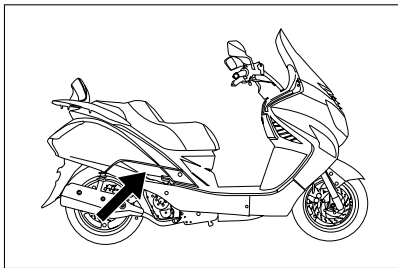

⚠ CAUTION

- Keep the battery away from fires.
- When disconnecting the battery wire, be sure to remove the negative (-) battery wire first with the ignition switch “” (OFF) position, then remove the positive (+) battery wire.
When reinstalling the battery, be sure to connect the positive (+) battery wire first, then connect the negative (-) battery wire.
- Fasten certainly the battery wires.
- Incorrect installation of the battery will reverse the terminal position resulting in possible electrical system damage due to incorrect battery lead connection.
- Never charge a battery while still in the machine as damage may result to the battery or regulator / rectifier.

The fuse box is located inside the right cover. If the engine suddenly stops running or any electrical system fails to operate then the fuse must be checked.

In case a fuse blows there is a 30A for main and 15A for head lamp spare fuse.

- 30A main fuse protects all electrical circuits.
- 15A head lamp fuse protects the head lamp and high beam indicator lamp.

⚠ CAUTION

Never use other than specified 30A or 15A fuse.

Installing a fuse of incorrect rating may seriously damage the electrical system.

You should consult your Hyosung dealer or a qualified service mechanic immediately.

HEAD LAMP

⦿ ADJUSTMENT OF THE HEAD LAMP BEAM

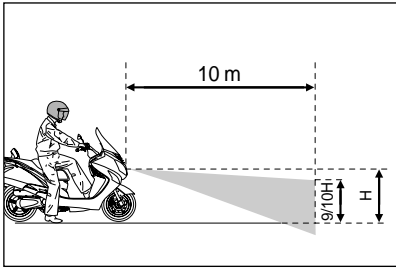

For a quick beam inspection, place the motorcycle on level ground, ten meters away from a vertical wall.

Switch on the low beam, sit astride the motorcycle and make sure that the lamp spot on the wall is just below the horizontal line of the head lamp (about nine-tenths of overall height).

Hi beam

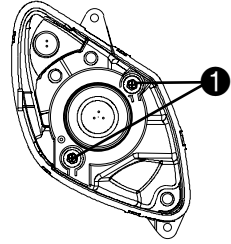

Low beam

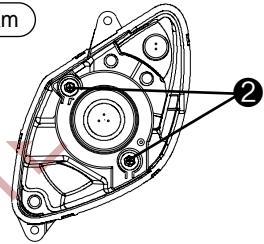

Turn the adjuster screws ①, ② of both head lamp bulbs with a screwdriver to adjust as follows : turn CLOCKWISE to lower the beam.

Turn COUNTER-CLOCKWISE to raise the beam.

BULBS

WARNING

Keep fuel and other flammable substances away from electric components.

CAUTION

Before changing a bulb, set the ignition switch to position “”(OFF) and allow a few minutes for the bulb to cool down.

Wear clean gloves or use a clean, dry cloth to handle the new bulb.

Do not put your fingerprints on the bulb, as this may lead to overheating and failure.

If you have handled the bulb with bare hands, clean it with alcohol to avoid any damage.

DO NOT PULL ON THE WIRES.

N O T E

Before changing a bulb, check the fuses.

INSPECTION OF LAMPS

- Check if the head lamp, position lamp, tail lamp, meter lamp and license plate lamp work well when the ignition switch is turned to the “”(ON) position.
- Check if the brake lamp work well when the front or rear brake lever was squeezed.
- Check if the turn signal lamp work well when the turn signal switch was operated.
- Check if the head lamp, tail lamp, turn signal lamp and brake lamp are dusty or damaged.

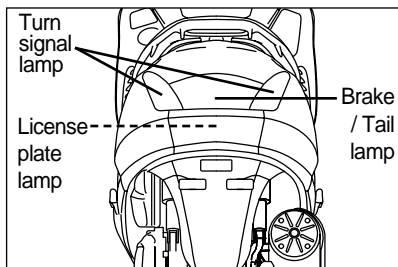
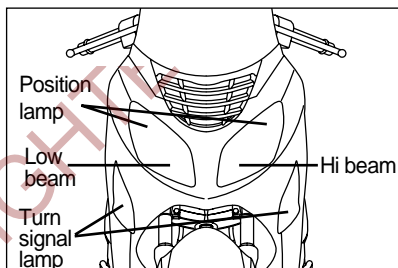

CAUTION

These motorcycles always come on the head lamp, position lamp, tail lamp, meter lamp and license plate lamp when the ignition switch is turned to the “”(ON) position.

⊙ REPLACEMENT OF THE LAMP

Requirement electric power of the lamp shown in the following chart.

When replace the damaged lamp, always use the equal capacity.

The use of a lamp other than rules may cause to excessive at the electric system or to damage the lamp.

NAMES		CAPACITY
Head lamp	HI	12V - 55W×1
	LO	12V - 55W×1
	Position	12V - 5W×2
Brake / Tail lamp		12V - 21/5W×1
Turn signal lamp		LED type
License plate lamp		12V - 5W×1

※ LED (Light Emitting Diode)

⚠ CAUTION

The use of a lamp other than rules may cause to occur the vehicle fire and to damage electric parts.
Surely use only the lamp of proper capacity.

⊙ TURN SIGNAL LAMP

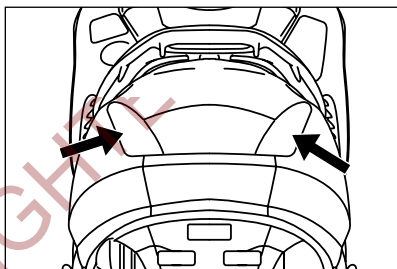
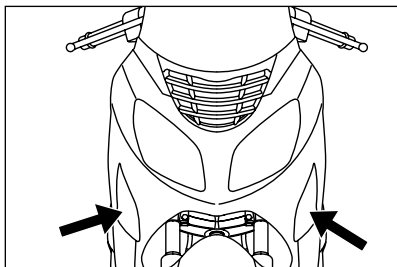

『MSB 850 / 85』's the turn signal lamps are LED (Light Emitting Diode) type. If any abnormal condition are found, replace the turn signal lamp assembly.

⊙ HEAD LAMP

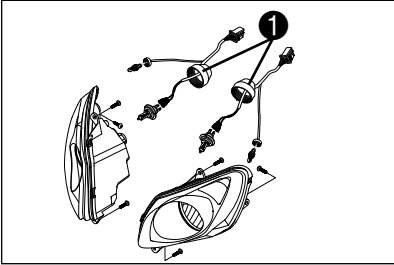

⚠ CAUTION

Never pull on the wiring to disconnect head lamp coupler.

1. Disconnect the head lamp coupler.
2. Remove the dust cover ① and socket spring.
3. After removing the bulb at the socket, replace the new bulb.
4. To install the head lamp, reverse the above sequence.

⚠ CAUTION

The use of a lamp other than rules may cause to occur the motorcycle fire and to damage electric parts.

Surely use only the bulb of proper capacity.

⊙ BRAKE / TAIL LAMP

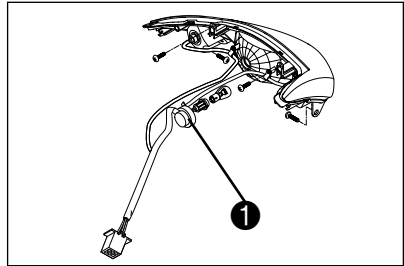

1. Lift the side cover. (Refer to page 70)
2. Turn the socket ① to the counter-clockwise and pull it out at the lamp housing.
3. Push in the bulb, turn it to the counter-clockwise and pull it out.
4. To fit the replacement bulb, push it in and turn it to the clockwise while pushing.

⊙ LICENSE PLATE LAMP

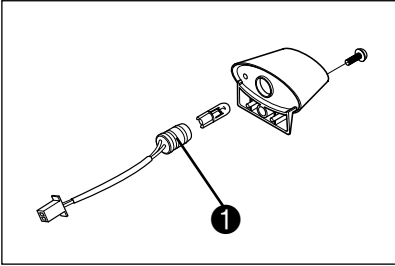

1. Lift the side cover. (Refer to page 70)
2. Pull out the socket ① at the lamp housing.
3. Pull out the bulb at the socket.
4. Replace the new bulb.
5. To install the license plate lamp, reverse the above sequence.

TROUBLESHOOTING

This troubleshooting guide is provided to help you find the cause of some common complaints.

⚠ CAUTION

Failure to troubleshoot a problem correctly can damage your motorcycle.

Improper repairs or adjustments may damage the motorcycle instead of fixing it. Such damage may not be covered under warranty.

If you are not sure about the proper action, consult your Hyosung dealer about the problem.

⊙ IGNITION SYSTEM CHECK

1. Remove the spark plug and reattach it to the spark plug lead.
2. Put the engine stop switch in the “○” position and ignition switch in the “○” (ON) position. While holding the spark plug base firmly against the engine, the front or rear brake lever is squeezed and push the electric starter switch. If the ignition system is operating properly, a blue spark should jump across the spark plug gap. If there is no spark, take your motorcycle to your **Hyosung** dealer.

WARNING

Performing the spark test improperly can be hazardous.

You could get a high voltage electrical shock or an explosion if you are not familiar with this procedure.

Do not perform this check if you are not familiar with the procedure.
Keep the spark plug away from the spark plug hole during this test. Do not this test if you have a heart condition or wear a pacemaker.

⊙ ENGINE STALLING

1. Check the fuel supply in the fuel tank.
2. Check the ignition system for intermittent spark.
3. Check the idle speed.

CAUTION

When occur any trouble, the best way is to consult your **Hyosung** dealer for repairs.

TRANSPORT

WARNING

Before transporting the motorcycle, it is necessary to empty the fuel tank completely, making sure that it is completely dry.

During transport, the motorcycle must be firmly secured in an upright position to avoid fuel, oil and coolant leaks.

⊙ DRAINING THE FUEL TANK

WARNING

Keep the fuel tank away from fires. Allow some time for the engine and muffler to cool down completely.

Fuel vapours are harmful to human health.

Ensure the area is well ventilated before proceeding.

Do not inhale fuel vapours.

Do not smoke, nor use naked flames.

- Place the motorcycle on the center stand on firm and level ground.
- Stop the engine and wait until it has cooled down.
- Prepare a container large enough to hold the fuel in the tank and place it on the floor on the left side of the motorcycle.
- Remove the fuel tank cap.
- Drain fuel using a manual pump or similar system. Do not damage the fuel pump assembly (fuel level sensor accommodated inside the tank).

WARNING

Refit the fuel tank cap after draining all fuel.

CLEANING PROCEDURE

A thorough cleaning of your motorcycle is a necessary part of maintenance and will help keep your motorcycle looking and performing its best. Proper cleaning can also extend the life of your motorcycle.

It is important to clean and inspect your motorcycle after every ride if it is used in mud, brush, grass, water, salt water, or very dusty conditions.

The build-up of mud, brush, grass, etc, especially on the engine and exhaust system, can reduce engine cooling, conceal damage, or increase wear of certain parts. It is important to remove all debris during cleaning.

CAUTION

High pressure washers can damage your motorcycle (especially the radiator pin).

High pressure washers such as those found at coin-operated car washes have enough pressure to damage the parts of your motorcycle. It may cause rust, corrosion and increase wear.

Do not use high pressure washers to clean your motorcycle.

⊙ WASHING YOUR motorcycle

With some care, your motorcycle can be washed in a similar manner to washing an automobile.

N O T E

Avoid spraying or allowing water to flow over the following places :

- Ignition switch
- Spark plug
- Fuel tank cap
- Fuel injection system
- Brake master cylinders
- Radiator fins
- Snorkel air intake for air cleaner

CAUTION

Do not use parts cleaner to throttle body and fuel injection sensors.

Use a garden hose at low pressure to remove the majority of dirt or other debris. Wash your motorcycle by hand with a mild soap or detergent and water. Try to thoroughly remove all dirt and debris without excessive water pressure. Cloth rags, washing mitts or cleaning brushes can be used, be careful with brushes as they may scratch plastic or painted surfaces. Rinse the motorcycle thoroughly with clean water. Dry all areas using a chamois or soft absorbent cloth.

⊙ WINDSHIELD CLEANING

Clean the windshield with a soft cloth and warm water with a mild detergent.

If scratched, polish with commercially available plastic polish.

Replace the windshield if it becomes scratched or discolored so as to obstruct view.

When replacing the windshield, use a Hyosung replacement windshield.

CAUTION

Cleaning with any alkaline or strong acid cleaner, gasoline, brake fluid, or any other solvent will damage the windshield.

Clean only with a soft cloth and warm water with a mild detergent.

⦿ WAXING THE MOTORCYCLE

After washing the motorcycle, waxing and polishing are recommended to further protect and beautify the paint.

- Only use waxes and polishes of good quality.
- When using waxes and polishes, observe the precautions specified by the manufacturers.

⦿ INSPECTION AFTER CLEANING

Remove the rags or wrapping from the exhaust pipe. For extended life of your motorcycle, lubricate according to "LUBRICATION POINTS" section.

WARNING

Operating motorcycle with wet brakes can be hazardous.

Wet brakes may not provide as much stopping power as dry brakes. This could lead to an accident.

Test your brakes washing motorcycle, riding at slow speed. If necessary, apply brakes several times to let friction dry out the pads.

Follow the procedures in the "INSPECTION BEFORE RIDING" section to check your motorcycle for any problems that may have arisen during your last ride.

STORAGE PROCEDURE

If you don't plan on using your motorcycle for a long time, it will need special servicing requiring appropriate materials, equipment and skill. For this reason, **Hyosung** recommends that you trust this maintenance work to your dealer. If you wish to service the machine for storage yourself, follow the general guidelines below :

⦿ MOTORCYCLE

Clean the entire motorcycle.

Place the motorcycle on the center stand on a firm, flat surface where it will not fall over.

Turn the handlebars all the way to the left and lock the steering, and remove the ignition key.

⦿ FUEL

Fill the fuel tank to the top with fuel.

⦿ BATTERY

1. Remove the battery from the motorcycle.

NOTE

Be sure to remove the negative terminal first, then remove the positive terminal.

2. Clean the outside of the battery with mild detergent and remove any corrosion from the terminals and wiring harness connections.
3. Store the battery in a room above freezing.

⦿ TIRES

Inflate the tires to the normal pressure.

⊙ EXTERNAL

- Spray all vinyl and rubber parts with rubber protectant.
- Spray the unpainted surfaces with rust preventative.
- Coat the painted surfaces with car wax.

⊙ MAINTENANCE DURING STORAGE

Once a month, recharge the battery. The standard charging rate is $0.8A \times 10$ hours.

★ PROCEDURE FOR RETURNING TO SERVICE

1. Clean the entire motorcycle.
2. Reinstall the battery.

N O T E

Be sure connect the positive terminal first, then connect the negative terminal.

3. Adjust the pressure of tires as described in the TIRE section.
4. Lubricate all places as instructed in this manual.
5. Perform the INSPECTION BEFORE RIDING as listed in this manual.

LABEL

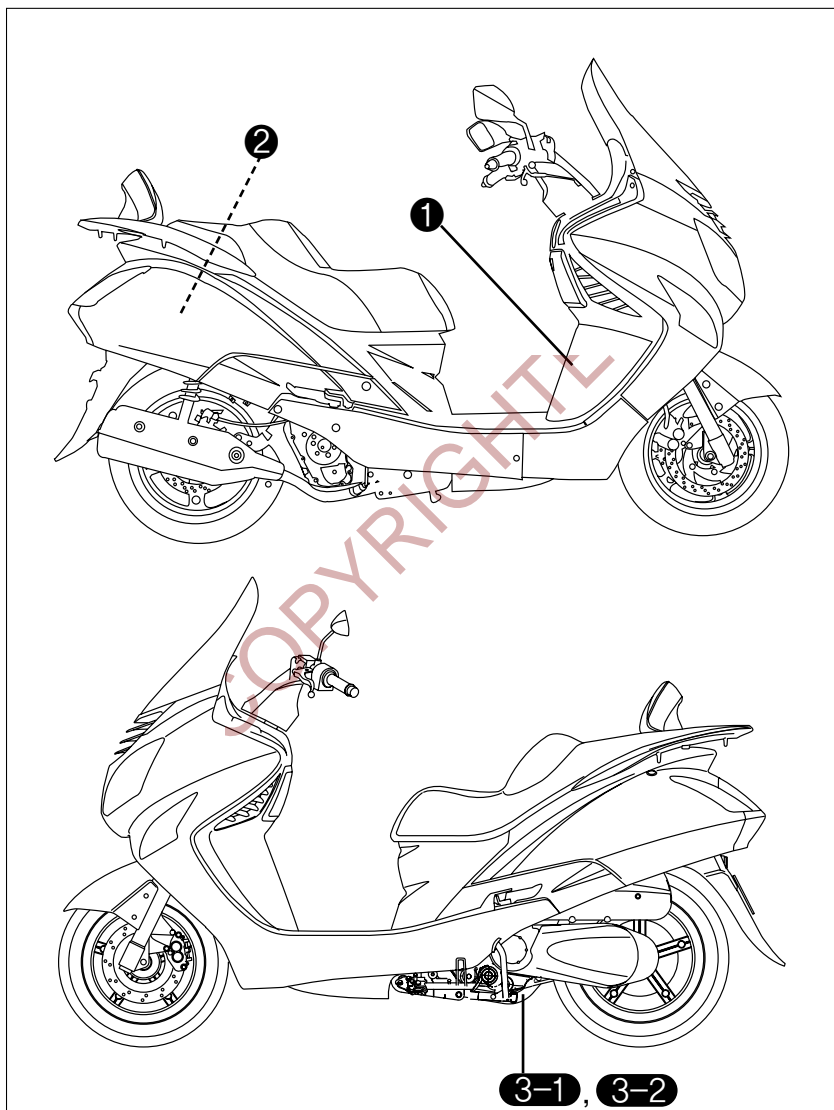

WARNING

- ▶ BE FULLY AWARE OF THE OWNER'S MANUAL BEFORE OPERATING AND RIDING.
- CERTAINLY WEAR A HELMET.
- OBSERVE THE DISTRICTED SPEED.
- DO NOT BE TOUCHED THE MUFFLER BECAUSE IT IS HOT.
- DO NOT DO ILLEGAL MODIFICATION FOR THE SAFE RIDING.
- ▶ MAX LOADING WEIGHT.
1. TRUNK : 10kg

- 2. REAR CARRIER : 5kg
- OPERATE THE INSPECTION AND THE MAINTENANCE ACCORDING TO THE REGULAR CHECKLIST OF THE OWNER'S MANUAL.
- ▶ THE CHECKLIST BEFORE RIDING
(DASHBOARD, HORN, LAMP, OIL, BRAKE, TIRE)

TIRE PRESSURE	FRONT	REAR
FOR 1 PERSON	25 psi (1.75kg/cm ²)	29 psi (2.00kg/cm ²)
FOR 2 PERSONS	25 psi (1.75kg/cm ²)	36 psi (2.50kg/cm ²)
SIZE	120/70-13 53S	140/60-14 64S

68319HP7650-PL

1

CAUTION

- Do not put something to be affected easily by the heat because the inside of trunk may be hotted.
- Do not put a valuables or a fragiles in the trunk.
- Make sure the seat were locked.
In case of riding with un-locked and it can cause an abnormal riding or dangerous in an emergency.
- Make sure the level of 4 stroke engine oil when you feed oil.
The driving without oil may cause a engine trouble.
- Use the hyosung genuine oil.
- Before riding, inspect the tire pressure, damage, abnormal wear and etc. according to the "inspection before riding"
- Be careful not to be entered water into the trunk and also be careful of something important in the trunk.
- Do not use spurious gasoline. It can cause a serious damage in engine.

68332HP7650-PL

2

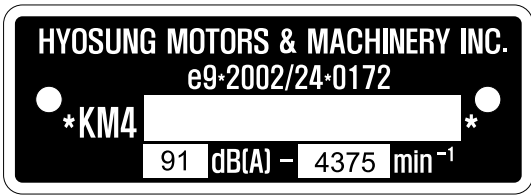

3-1

(For 『MSB 850』)

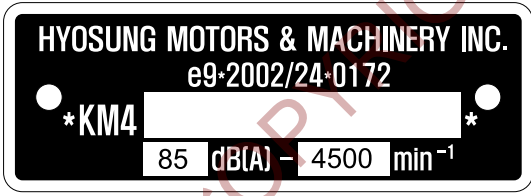

3-2

(For 『MSB 125』)

SPECIFICATIONS

DIMENSIONS AND DRY MASS

	MS3 250	MS3 125
Overall length	2,125 mm (83.7 in)	←
Overall width	765 mm (30.1 in)	←
Overall height	1,365 mm (53.7 in)	←
Wheelbase	1,500 mm (59.1 in)	←
Ground clearance	120 mm (4.7 in)	←
Mass	180 kg (397 lbs)	175 kg (386 lbs)

ENGINE

	MS3 250	MS3 125
Type	Four-stroke, DOHC, Liquid-cooled	←
Number of cylinder	1	←
Bore	73.0 mm (2.87 in)	57.0 mm (2.24 in)
Stroke	59.6 mm (2.35 in)	48.8 mm (1.92 in)
Piston displacement	249.5 cm ³ (15.2 in ³)	124.5 cm ³ (7.6 in ³)
Fuel system	Fuel injection	←
Starter system	ELECTRIC STARTER	←

TRANSMISSION

	MS3 250	MS3 125
Clutch	Dry shoe, automatic, centrifugal type	←
Reduction ratio	7.31	10.82
Drive belt	V-belt drive	←
Transmission	0.875 ~ 2.415	0.851 ~ 2.806

CHASSIS

	MSB 1250	MSB 1235
Front suspension	Telescopic type	←
Rear suspension	Swingarm type	←
Caster	26°	←
Trail	88.5 mm (3.5 in)	←
Steering angle	37° (right & left)	←
Front tire size	120/70 - 13M/C 53S	←
Rear tire size	140/60 - 14M/C 64S	←
Front brake	Double disk	←
Rear brake	Disk	←

ELECTRICAL

	MSB 1250	MSB 1235
Ignition type	ECU	←
Ignition timing	10° B.T.D.C. at 1,500rpm	←
Spark plug	CR8E	←
Battery	12V 8Ah (MF)	←
Fuse	Main : 30A, Head lamp : 15A	←
Head lamp	HI : 12V - 55W×1	←
	LO : 12V - 55W×1	←
	Position : 12V - 5W×2	←
License plate lamp	12V - 5W×1	←
Turn signal lamp	LED type	←
Brake / Tail lamp	12V - 21/5W×1	←

CAPACITIES

	MSB 1250	MSB 1235
Fuel tank	8.0 ℓ	←
Engine oil	800 ml (Replace)	←
	900 ml (Oil filter replace)	
	1,000 ml (Overhaul)	
Transmission oil	360 ml (Replace)	←
	400 ml (Overhaul)	

COPYRIGHT

COPYRIGHT

Prepared by

 **HYOSUNG**
S&T Motors Co., Ltd.

1st Ed. MAY. 2007.

Printed in KOREA

S&T Motors Co., Ltd.

1st Ed.

Part No. 99011HP7610
MAY. 2007.
Printed in KOREA