

For Maintenance and Safety

INDIAN FTR OWNER'S MANUAL



2022



WARNING

Read, understand, and follow all of the instructions and safety precautions in this manual and on all product labels.

Failure to follow the safety precautions could result in serious injury or death.



WARNING

Operating, servicing, and maintaining a passenger vehicle or off-road vehicle can expose you to chemicals including engine exhaust, carbon monoxide, phthalates, and lead, which are known to the State of California to cause cancer and birth defects or other reproductive harm. To minimize exposure, avoid breathing exhaust, do not idle the engine except as necessary, service your vehicle in a well-ventilated area and wear gloves or wash your hands frequently when servicing your vehicle.

For more information go to www.P65Warnings.ca.gov/passenger-vehicle.



2022 Owner's Manual

Indian Motorcycle FTR
Indian Motorcycle FTR Rally
Indian Motorcycle FTR S
Indian Motorcycle FTR R Carbon

All information contained within this publication is based on the latest product information available at the time of publication. Product improvements or other changes may result in differences between this manual and the motorcycle. Depictions and/or procedures in this publication are intended for reference use only.

No liability can be accepted for omissions or inaccuracies. Indian Motorcycle reserves the right to make changes at any time, without notice and without incurring obligation to make the same or similar changes to motorcycles previously built. Any reprinting or reuse of the depictions and/or procedures contained within, whether whole or in part, is expressly prohibited.

Unless noted, trademarks are the property of Indian Motorcycle International, LLC

Ride Command® is a registered trademark of Polaris, Inc. Dunlop® is a registered trademark of DNA (Housemarks) Limited. BatteryMINDER® is a registered trademark of VDC Electronics, Inc. iPhone®, Apple®, App Store®, and Apple CarPlay® are registered trademarks of Apple Inc. iOS® is a registered trademark of Cisco Technology, Inc. Google Play™ is a registered trademark of Google, Inc. Bluetooth® is a registered trademark of Bluetooth Sig, Inc. AXALTA® is a registered trademark of Axalta Coating Systems IP Co. Pirelli®, Scorpion®, Metzeler®, and Sportec® are registered trademarks of PIRELLI TYRE S.P.A. Google Play® is a registered trademark of Google, LLC. NGK® is a registered trademark of NGK Spark Plug Co., LTD..

CONGRATULATIONS!

Congratulations on your purchase of a new INDIAN MOTORCYCLE. You have joined an elite family of motorcycle riders who have acquired a celebrated piece of American history by choosing to own an INDIAN MOTORCYCLE.

Your new motorcycle is the end result of true dedication and craftsmanship by our engineering, design and assembly teams. It was designed and manufactured to meet our goal of providing you with a high quality motorcycle that you can ride trouble-free for many years to come. We hope you will take as much pride in riding your new motorcycle as our team did in building it for you.

We urge you to read this rider's manual thoroughly. It contains information essential to safe riding and proper maintenance of your motorcycle.

Your authorized INDIAN MOTORCYCLE dealer knows your motorcycle best and should be consulted for service and assistance. Skilled technicians using advanced equipment and methods are best qualified to perform all major repairs and service your motorcycle may require.

INDIAN MOTORCYCLE comply with all federal, state and local safety and emission regulations for the area of intended sale.

SAFETY SYMBOLS AND SIGNAL WORDS

The following signal words and symbols appear throughout this manual. Your safety and the safety of others is involved when these words and symbols are used. Become familiar with their meanings before reading the manual.



DANGER indicates a hazardous situation which, if not avoided, **WILL** result in death or serious injury.



WARNING indicates a hazardous situation that, if not avoided, **may** result in death to the operator, bystanders or person(s) inspecting or servicing the vehicle.



SAFETY ALERT CAUTION indicates a potential hazard that may result in minor personal injury or damage to the vehicle.

IMPORTANT

IMPORTANT provides key reminders during disassembly, assembly, and inspection of components.

NOTICE

NOTICE provides key information by clarifying instructions.

TIP

TIP provides a piece of advice or an authoritative instruction.

Introduction. **7**

Safety. **11**

 Reporting Safety Defects 19

Features and Controls **23**

Pre-Ride Inspections **53**

Operation. **65**

Maintenance **77**

Troubleshooting. **143**

Cleaning and Storage **147**

Specifications. **153**

Warranty **159**

Maintenance Log **171**

INTRODUCTION

SERVICE AND WARRANTY INFORMATION

Some procedures are beyond the scope of this manual. See your dealer to purchase an *INDIAN MOTORCYCLE Service Manual*. Some procedures provided in the service manual require specialized knowledge, equipment, and training. Be sure you have the required technical skills and tools that are needed before you attempt ANY service on your motorcycle. Please contact your authorized dealer before attempting any service work that is beyond your level of technical knowledge or experience, or if the work requires specialized equipment.

OPERATING MOTORCYCLE OUTSIDE THE U.S.A.

If you plan to operate your motorcycle in countries other than the USA and Canada:

- Service facilities or replacement parts may not be readily available.
- Unleaded gasoline may not be available. The use of leaded fuels will cause engine damage, damage to your emissions systems and voiding of your warranty.
- Gasoline may have a considerably lower octane rating. Improper fuel can cause engine damage.

KEY IDENTIFICATION NUMBER

The key identification number is stamped on the metal key tag attached to the key ring. If it becomes necessary to replace the ignition key for any reason, provide the key number to your **INDIAN MOTORCYCLE** dealer.

ENGINE IDENTIFICATION NUMBER

The engine number ① is stamped into the bottom of the left crankcase near the sidestand.

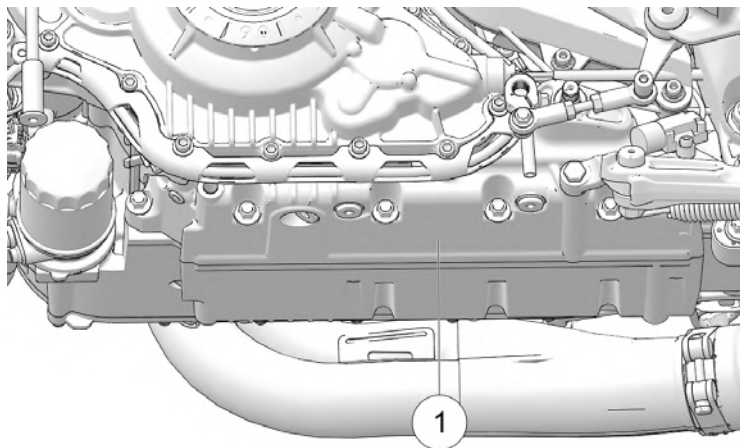

INTRODUCTION

IDENTIFICATION NUMBER RECORD

| RECORD IMPORTANT IDENTIFICATION NUMBERS BELOW. | |
|--|--|
| Vehicle Identification Number (VIN) | |
| Engine Identification Number | |
| Ignition Key Number | |

INDUSTRY CANADA ICES-002 (INTERFERENCE-CAUSING EQUIPMENT STANDARD)

This vehicle complies with the Canadian standard ICES-002.

TOUCHSCREEN DISPLAY COMPLIANCE STATEMENT

Notice: This device complies with part 15 of the FCC Rules and with Industry Canada license-exempt RSS standard(s). Operation is subject to the following two conditions: (1) this device may not cause interference, and (2) this device must accept any interference received including interference that may cause undesired operation.

Per RSS-Gen, Section 8.4, this device complies with Industry Canada license-exempt RSS standard(s). Operation is subject to the following two conditions: (1) this device may not cause interference, and (2) this device must accept any interference, including interference that may cause undesired operation of the device.”

Polaris International hereby declares that the radio equipment in-vehicle display unit is in compliance with the following directives:

- 2014/53/EU European Radio Equipment Directive
- 2011/65/EU RoHS 2011/65/EU (Recast)
- 2015/863 RoHS July 22, 2019

The full text of the EU declaration of conformity is available at the following internet address: www.polaris.com/compliance

Per 47 CFR 15.21, the user’s manual for instruction or an intentional or unintentional radiator shall caution the user that changes or modifications not expressly approved by the party responsible for compliance could void the user’s authority to operate the equipment.



This equipment complies with part 15 of the Federal Communications Commission (FCC) rules. These requirements are intended to provide reasonable protection against harmful interference in a residential installation. This equipment generates, uses and can radiate radio frequency energy and, if not installed and used in accordance with the instructions, may cause harmful interference to radio communications. However, there is no guarantee that interference will not occur in a particular installation.

 **CAUTION**

If this equipment does cause harmful interference to radio or television reception, which can be determined by turning the equipment off and on, the user is encouraged to try to correct the interference by one or more of the following measures:

- Reorient or relocate the receiving antenna.
- Increase the separation between the equipment and receiver.
- Connect the equipment into an outlet on a circuit different from that to which the receiver is connected.
- Consult the dealer or an experienced radio/TV technician for help.

Changes or modifications to this equipment not expressly approved by the party responsible for compliance could void the user's authority to operate the equipment.

SAFETY ABOUT THE RIDER'S MANUAL

WARNING

Failure to follow all recommended precautions and procedures could result in serious injury or death. Always heed all safety precautions and follow all operation, inspection and maintenance procedures outlined in this manual.

All references to RIGHT, LEFT, FRONT or REAR are from the operator's perspective when seated in a normal riding position. If you have questions about the operation or maintenance of your motorcycle after you've read this manual, please see your authorized dealer. To locate the nearest authorized INDIAN MOTORCYCLE dealer, visit the INDIAN MOTORCYCLE web site at www.indianmotorcycle.com.

Carefully read and understand the information found in the *Safety* section beginning on this page. To keep your motorcycle in peak condition on the road or in storage, understand and follow the procedures outlined in the *Maintenance* section beginning on page 77.

Bring the manual along when you ride. Following the precautions and procedures in the manual will add to your enjoyment and help keep you safe. If you lose or damage this manual, please purchase a new one through any authorized INDIAN MOTORCYCLE dealer. This rider's manual should be considered part of the motorcycle and should remain with the motorcycle when ownership changes.

SAFE RIDING PRACTICES

WARNING

Improper use of this motorcycle can result in serious injury or death. To minimize the risk, read and understand the information contained in this section before operating the motorcycle. This section contains safety information specific to the INDIAN MOTORCYCLE, as well as information about general motorcycle safety. Anyone who rides the motorcycle (operators and passengers) must follow these safety precautions.

MOTORCYCLING HAS INHERENT RISKS

You can minimize those risks, but you can't eliminate them completely. Even if you're an experienced motorcycle operator or passenger, read all of the safety information in this manual before operating the motorcycle.

- Take a rider education course from a qualified instructor. The course will help you develop or refresh your expertise in safe riding habits through instruction and riding.
- Read and understand all information in this rider's manual.
- Observe all maintenance requirements specified in this manual. See the *INDIAN MOTORCYCLE Service Manual* or an authorized INDIAN MOTORCYCLE dealer.

DESIGN CHARACTERISTICS AFFECT HOW YOU SHOULD RIDE THE MOTORCYCLE

- The motorcycle is designed for on-road use with one rider (and one passenger if the motorcycle is equipped with a passenger seat and pegs). *Never exceed the GVWR or the GAWR.* Refer to the *Specifications* chapter or the Manufacturing Information/VIN label on the motorcycle frame for model-specific information.
- Riding off-road, riding with more than one passenger, or carrying weight exceeding the maximum weight rating can make handling difficult, which could cause loss of control.
- During the first 500 miles (800 km) of operation, follow all break-in procedures as outlined on page 65. Failure to do so can result in serious engine damage.
- If your motorcycle is equipped with saddlebags, a windshield or a passenger backrest, be prepared to reduce operating speed to maintain stability.

FOLLOW THESE GENERAL SAFE RIDING PRACTICES

- Before each ride, perform the pre-ride inspections. Failure to do so may result in damage to the motorcycle or an accident.
- Until you're thoroughly familiar with the motorcycle and all of its controls, practice riding where there is little or no traffic. Practice riding at a moderate speed on various road surfaces and in different weather conditions.
- Know your skills and limits, and ride within them.
- Allow only licensed, experienced operators to ride your motorcycle, and then only after they have become familiar with its controls and operation. Make sure all riders read and understand this rider's manual before riding.
- Do not ride when you're fatigued, ill or under the influence of alcohol, prescription drugs, over-the-counter drugs or any other drugs. Fatigue, illness, alcohol and drugs can cause drowsiness, loss of coordination and loss of balance. They can also affect your awareness and judgment.
- If your motorcycle operates abnormally, correct the problem immediately. See the *INDIAN MOTORCYCLE Service Manual* or an authorized INDIAN MOTORCYCLE dealer or other qualified dealer.
- Ride defensively, as if you are invisible to other motorists, even in broad daylight. *A motorist's failure to see or recognize a motorcycle is the leading cause of automobile/motorcycle accidents.* Ride where you're clearly visible to other motorists, and observe their behavior carefully.
- Be especially cautious at intersections, as these are the most likely places for an accident.
- To prevent loss of control, keep your hands on the handlebars and your feet on the footrests.
- Obey the speed limit and adjust your speed and riding technique based on road, weather and traffic conditions. As you travel faster, the influence of all other conditions increases, which can affect the motorcycle's stability and increase the possibility of losing control.
- Do not move or operate the motorcycle with the steering locked (if equipped), as the severely restricted steering could result in loss of control.

- Reduce speed when:
 - The road has potholes or is otherwise rough or uneven.
 - The road contains sand, dirt, gravel or other loose substances.
 - The road is wet, icy or oily.
 - The road contains painted surfaces, manhole covers, metal grating, railway crossings or other slippery surfaces.
 - The weather is windy, rainy or otherwise causing slippery or rapidly changing conditions.
 - Traffic is heavy, congested, not allowing sufficient space between vehicles or otherwise not flowing smoothly.
 - You are being passed in either direction by a large vehicle that may produce a wind blast in its wake.
- When approaching a curve, choose a speed and lean angle that allows you to pass through the curve in your own lane without applying the brakes. Excessive speed, improper lean angle or braking in a curve can cause loss of control.
- Ground clearance is reduced when the motorcycle leans. Do not allow components to contact the road surface when leaning the motorcycle in a curve, as this could cause loss of control.
- Do not tow a trailer. Towing a trailer can make the motorcycle hard to handle.
- Retract the sidestand fully before riding. If the sidestand is not fully retracted, it could contact the road surface and cause loss of control.
- To maximize braking effectiveness, *use the front and rear brakes together*. Be aware of the following braking facts and practices:
 - The rear brake provides 40% of the motorcycle's stopping power, at most. Use the front and rear brakes together.
 - To avoid skidding, apply the brakes gradually when the road is wet or rough, or contains loose or other slippery substances.
 - If possible, avoid applying the brakes while making a turn. Motorcycle tires have less traction during turns, so braking will increase the possibility of skidding. Bring the motorcycle to the upright position before applying the brakes.
 - With new pads and rotors, allow up to 250 miles (500 km) of operation in urban driving conditions (not highway cruising) to allow pads to mate with new rotors. Brakes should be used frequently. During this time brake performance will be less effective. Avoid using brakes harshly unless in an emergency. Brake efficiency will gradually increase during this seating period.

PROTECTIVE APPAREL

IMPORTANT

Wear protective apparel to decrease the risk of injury and increase riding comfort.

- Always wear a helmet that meets or exceeds established safety standards. Approved helmets in the USA and Canada bear a U.S. Department of Transportation (DOT) label. Approved helmets in Europe, Asia and Oceania bear the ECE 22.05 label. The ECE mark consists of a circle surrounding the letter E, followed by the distinguishing number of the country which has granted approval. The approval number and serial number will also be displayed on the label. Laws in some areas *require* that you wear an approved helmet. Head injuries are the leading cause of fatalities in accidents involving motorcycles. Statistics prove that an approved helmet is the most effective protection in preventing or reducing head injuries. The helmet should fit snugly, be securely fastened, have no obvious defects, and have not previously been involved in an accident/crash.
- Wear eye protection to protect eyes from wind or airborne particles and objects. Wearing a face shield can help protect your face in an accident/crash and protect face from wind or airborne particles or objects. Laws in some areas *require* that you wear eye protection. We recommend that you wear approved Personal Protective Equipment (PPE) bearing markings such as VESC 8, V-8, Z87.1, or CE. Make sure protective eyewear is kept clean.

- All riders should wear bright or light-colored and/or reflective clothing to improve visibility to other motorists. *A motorist's failure to see or recognize a motorcycle is the leading cause of automobile/motorcycle accidents.*
- Wear gloves, a jacket, heavy boots and long pants to prevent or reduce injury from abrasions, lacerations or burns should the motorcycle fall. Wear boots with low heels, as high heels can catch on pedals or footrests. The combination of boots and pants should completely cover legs, ankles and feet, protecting skin from engine and exhaust system heat.
- Do not wear loose, flowing clothing or long boot laces, as they can catch on handlebars, levers or footrests, or they can become entangled in the wheels, causing loss of control and serious injury.

ANTI-LOCK BRAKE SYSTEM RESPONSE

When the anti-lock brakes engage during a braking event, the rider will feel pulsing at the brake levers. *Continue to apply steady pressure to the brakes for the best stopping performance.*

CARRYING A PASSENGER



Do not carry a passenger unless the motorcycle is equipped with passenger seat and passenger footrests.

- Do not exceed the gross vehicle weight rating (GVWR) or the gross axle weight rating (GAWR) for your motorcycle. Refer to the *Specifications* section of this manual or the Manufacturing Information/VIN label on the motorcycle frame for model-specific information.
- Adjust ride height as needed. See the *Rear Shock Preload (Ride Height) Inspection* and *Rear Shock Preload (Ride Height) Adjustment* sections for details.
- Direct the passenger to hold onto you or to the passenger handholds with both hands and to keep both feet on the passenger footrests. Do not carry a passenger who cannot place both feet firmly on the passenger footrests. A passenger who is not holding on properly, or who cannot reach the passenger footrests, can shift their body erratically, which can make the motorcycle hard to handle and cause loss of control.
- Before riding, be sure your passenger knows safe riding procedures. Discuss any safety information unfamiliar to your passenger. A passenger who is unaware of safe riding procedures may distract you or make movements that make the motorcycle hard to handle.
- Adjust your riding style to compensate for the differences in handling, acceleration and braking caused by the additional weight of the passenger. Failure to do so can cause loss of control.

USE OF ACCESSORIES

Because INDIAN MOTORCYCLE cannot test and make specific recommendations concerning every accessory or combination of accessories sold, the operator is responsible for determining that the motorcycle can be safely operated with any accessories or additional weight. Use the following guidelines when choosing and installing accessories:

- Do not install accessories that impair operator visibility or the stability, handling or operation of the motorcycle. Before installing an accessory, be sure that it does not:
 - reduce ground clearance when the motorcycle is either leaned or in a vertical position;
 - limit suspension or steering travel or your ability to operate controls;
 - displace you from your normal riding position;
 - obscure lights or reflectors.
- Bulky, heavy or large accessories can cause instability (due to the lifting or buffeting effects of wind) and loss of control.
- Do not install electrical accessories that exceed the capacity of the motorcycle's electrical system. Never install higher wattage light bulbs than those supplied as original equipment. An electrical failure could result and cause hazardous loss of engine power or lights, or damage to the electrical system. See the Electrical Precautions section for details.
- Use only genuine INDIAN MOTORCYCLE accessories designed for your model.
- Do not exceed the GROSS VEHICLE WEIGHT RATING (GVWR) or the GROSS AXLE WEIGHT RATING (GAWR) for your motorcycle.

SAFETY

MODIFICATIONS

Modifying the motorcycle by removing any equipment or by adding equipment not approved by the manufacturer may void your warranty. Some modifications may not be legal in your area of operation. If in doubt, contact your authorized INDIAN MOTORCYCLE dealer.



Modifications could make the motorcycle unsafe to ride and could result in serious injury to operator or passenger, as well as damage to the motorcycle.

PARKING THE MOTORCYCLE

When leaving the motorcycle unattended, turn the engine off. Your motorcycle is equipped with a keyed ignition. Remove the ignition key to prevent unauthorized use.

Park the motorcycle where people are not likely to touch the hot engine or exhaust system or place combustible materials near these hot areas. Do not park near a flammable source such as a kerosene heater or an open flame, where hot components could ignite combustible materials.

Park the motorcycle on a firm, level surface. Sloped or soft surfaces may not support the motorcycle. If you must park on a slope or soft surface, follow the precautions outlined on page 74.

SADDLEBAG

Whenever operating with a saddlebag or while carrying cargo:

- Never ride at excessive speeds. Saddlebags and cargo, combined with the lifting or buffeting effects of wind, can make the motorcycle unstable and cause loss of control.
- Do not exceed the individual weight limit of the saddlebag.
- NEVER EXCEED GROSS VEHICLE WEIGHT RATING (GVWR) or the GROSS AXLE WEIGHT RATING (GAWR), regardless of whether or not the saddlebag is loaded to capacity. Exceeding the weight rating can reduce stability and handling and cause loss of control.

CARRYING CARGO

Use the following guidelines when attaching cargo or accessories to the motorcycle. Where applicable, these guidelines also refer to the contents of any accessories.

- Keep cargo and accessory weight to a minimum, and keep items as close to the motorcycle as possible to minimize a change in the motorcycle's center of gravity. Changing the center of gravity can cause loss of stability and handling and could cause loss of control.
- Do not exceed the GROSS VEHICLE WEIGHT RATING (GVWR) or the GROSS AXLE WEIGHT RATING (GAWR) for your motorcycle.

- Distribute weight evenly on both sides of the motorcycle. Maintain even weight distribution by checking accessories and cargo to make sure they're securely attached to the motorcycle before riding and whenever you take a break from riding. Uneven weight distribution or sudden shifting of accessories or cargo while you're riding may cause difficult handling, loss of control and driving hazards for other motorists (if cargo falls from the motorcycle).
- For riding comfort and to ensure proper ground clearance, adjust rear shock preload. See the Rear Shock Preload (Ride Height) Inspection section for details.
- Do not attach large or heavy cargo such as sleeping bags, duffel bags or tents to the handlebars, front fork area or front fender. Cargo or accessories placed in these areas can cause instability (due to improper weight distribution or aerodynamic changes) and could cause loss of control.
- Do not exceed the maximum cargo weight limit of any accessory (see accessory instructions and labels). Do not attach cargo to an accessory not designed for that purpose. Either circumstance could result in an accessory failure that could cause loss of control.
- Always obey posted speed limits.
- Do not attach anything to the motorcycle unless specifically designed for that purpose by INDIAN MOTORCYCLE.

TRANSPORTING THE MOTORCYCLE

If you must transport the motorcycle:

- Use a truck or trailer. Do not tow the motorcycle with another vehicle, as towing will impair the motorcycle's steering and handling.
- Position and restrain the motorcycle in an upright position.
- Do not restrain the motorcycle using the handlebars.
- Loop tiedown straps (from the front) up and over the lower triple clamp, using care to not interfere with wiring and brake lines. Place tiedowns as wide apart as possible on the truck or trailer bed for best stability.
- Do not engage the side stand during truck or trailer transportation.

FUEL AND EXHAUST SAFETY

Always heed these fuel safety warnings when refueling or servicing the fuel system.



WARNING

Gasoline is highly flammable and explosive under certain conditions.

- Always exercise extreme caution whenever handling gasoline.
- Always turn off the engine before refueling.
- Always refuel outdoors or in a well-ventilated area.
- Open the fuel cap slowly. Do not overfill the tank. Do not fill the tank neck.
- Do not smoke or allow open flames or sparks in or near the area where refueling is performed or where gasoline is stored.

SAFETY

WARNING

Gasoline and gasoline vapors are poisonous and can cause serious injury.

- Do not swallow gasoline, inhale gasoline vapors, or spill gasoline. If you swallow gasoline, inhale more than a few breaths of gasoline vapor, or get gasoline in your eyes, see a physician immediately.
- If gasoline spills on your skin or clothing, immediately wash it off with soap and water and change clothing.
- Exhaust gases contain carbon monoxide, a colorless, odorless gas that can cause loss of consciousness or death in a short time.
- Never start the engine or let it run in an enclosed area.
- Never inhale exhaust gases.

SAFETY MAINTENANCE

WARNING

Failure to perform safety maintenance as recommended can result in difficult handling and loss of control, which could result in serious injury or death. Always perform the safety maintenance procedures as recommended in this manual. Perform maintenance and repairs promptly. See the INDIAN MOTORCYCLE Service Manual or an authorized INDIAN MOTORCYCLE dealer or other qualified dealer.

- Before each ride, perform the *Pre-Ride Inspections*.
- Perform all periodic maintenance at the recommended intervals outlined in the *Periodic Maintenance* section.
- Always maintain proper tire pressure, tread condition and wheel and tire balance. Inspect tires regularly and replace worn or damaged tires promptly. Use only approved replacement tires. See the *Specifications* section.
- Always ensure proper steering head bearing adjustment. Regularly inspect the rear shock absorber and the front forks for fluid leaks or damage. Make any necessary repairs promptly. See page 118.
- Clean the motorcycle thoroughly to reveal items in need of repair.
- Always ensure all exhaust heat shields are present and in good condition.
- Fasteners must meet original specifications for quality, finish and type to ensure safety. Use only genuine INDIAN MOTORCYCLE replacement parts, and ensure that all fasteners are tightened to the proper torque.

GROSS VEHICLE WEIGHT RATING (GVWR)



Exceeding the gross vehicle weight rating of your motorcycle can reduce stability and handling and could cause loss of control. NEVER exceed the GVWR of your motorcycle.

The *maximum load capacity* of your motorcycle is the maximum weight you may add to your motorcycle *without exceeding the GVWR*. This capacity is determined by calculating the difference between your motorcycle's GVWR and wet weight.

Refer to the *Specifications* section of this manual or the Manufacturing Information/VIN label on the motorcycle frame for model-specific information.

When determining the weight you will be adding to your motorcycle, and to ensure you do not exceed the maximum load capacity, include the following:

- Operator body weight
- Passenger body weight
- Weight of all rider's apparel and items in or on apparel
- Weight of any post-production accessories and their contents
- Weight of any additional cargo on the motorcycle

REPORTING SAFETY DEFECTS

If you believe that your vehicle has a defect that could result in a crash or cause injury or death, you should immediately inform the National Highway Traffic Safety Administration (NHTSA) in addition to notifying INDIAN MOTORCYCLE in writing.

If NHTSA receives similar complaints, it may open an investigation, and if it finds that a safety defect exists in a group of vehicles, it may order a recall and remedy campaign. However, NHTSA cannot become involved in individual problems between you, your INDIAN MOTORCYCLE dealer or INDIAN MOTORCYCLE.

To contact NHTSA, or obtain other information about motor vehicle safety, you may either call the Vehicle Safety Hotline toll-free at 1-888-327-4236 (TTY: 1-800-424-9153), visit the NHTSA web site at www.safercar.gov, or write to:

ADMINISTRATOR, NHTSA
1200 New Jersey Avenue, SE
West Building
Washington, DC 20590

To report a safety defect to Transport Canada, you may either fill out an online defect complaint form at their website (English: <http://www.tc.gc.ca/recalls>, French: <http://www.tc.gc.ca/rappels>) or contact their Defect Investigations and Recalls Division by calling toll-free 1-800-333-0510 (Canada) or 819-994-3328 (Ottawa-Gatineau area / International).

SAFETY

SAFETY AND INFORMATION LABELS

Labels are model-specific and market-specific. Your motorcycle may not contain all of the labels shown.

VEHICLE IDENTIFICATION NUMBER

The Vehicle Identification Number (VIN) is stamped on the right-hand side of the steering head ①, and printed on a VIN sticker located on the left-hand side of the steering head.

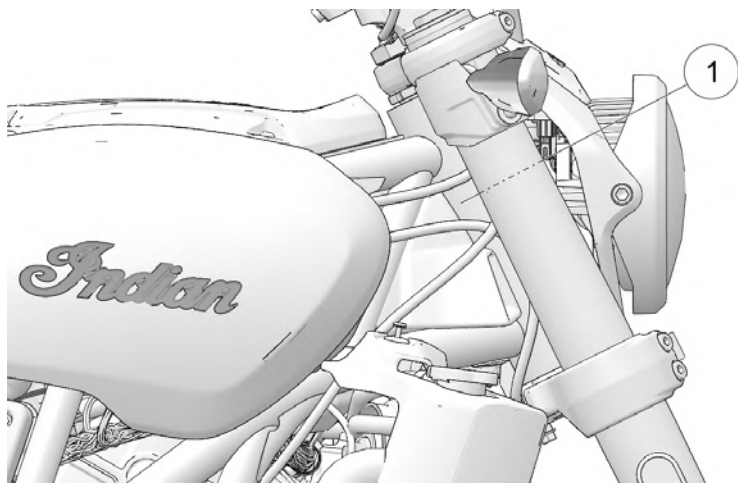

VEHICLE EMISSION INFORMATION

The Vehicle Emission Control Information (VECI) and Noise Emission Control Information (NECI) can be found on the emission information label. The label ② is located on the swing arm on the left-hand side of the vehicle.

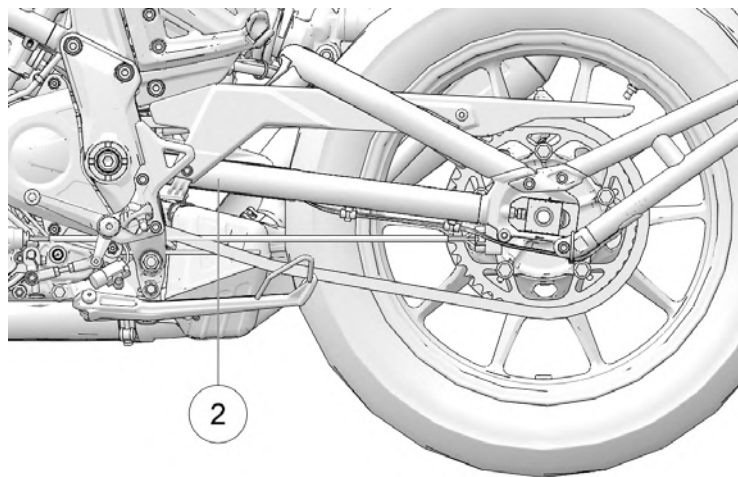

OPERATOR WARNING/FUEL CAUTION

The Operator Warning/Fuel Caution is located on the right-hand side panel ③.

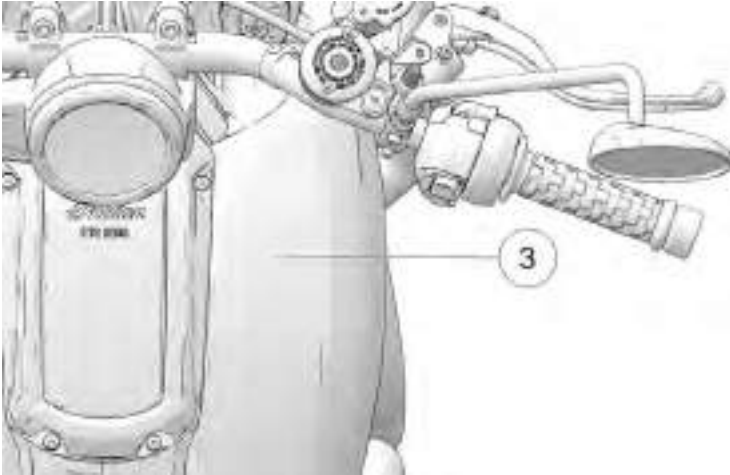

WARNING

- Read Owner's Manual and, during use, follow all safety precautions.
- Always wear an approved helmet, eye protection, and protective clothing.
- If your Owner's Manual is missing, contact an Indian Motorcycle dealer for a replacement.

CAUTION

Never overfill fuel tank. Fuel level should not rise into fill neck funnel. Overfilling may result in degraded performance of engine and evaporative emission control system.

FEATURES AND CONTROLS OVERVIEW

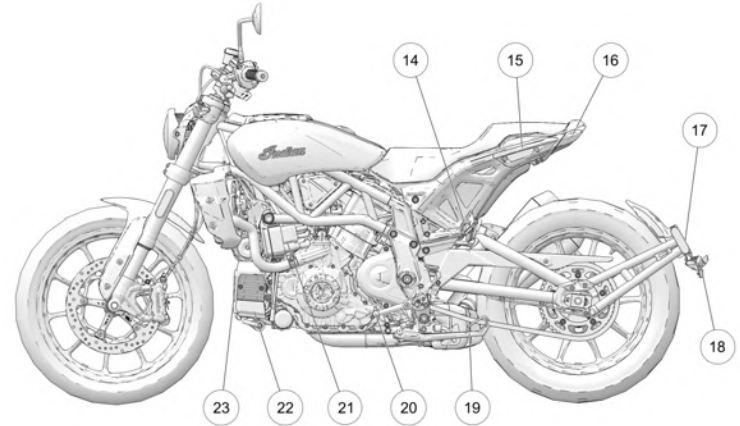
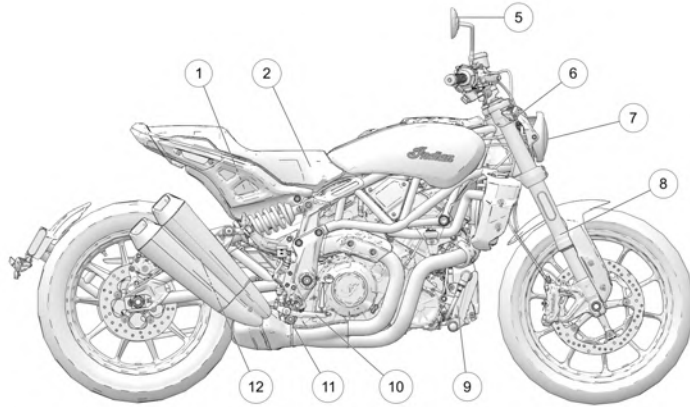

① Fuel Tank

② Seat

③ Fuse Box (under cover)

④ Air Filter

⑤ Mirror

⑥ Front Turn Signal

⑦ Headlight

⑧ Front Fork

⑨ Oil Cooler

⑩ Rear Brake Pedal

⑪ Driver Pegs

⑫ Muffler

⑬ Ignition Switch

⑭ Passenger Pegs

⑮ Passenger Hand-hold

⑯ Tail and Brake Light

⑰ License Plate Bracket

⑱ Rear Turn Signal

⑲ Sidestand

⑳ Shifter

㉑ Carbon Canister (if equipped)

㉒ Main/ABS Fuses

㉓ Battery

㉔ Radiator

CONSOLE FTR / FTR RALLY

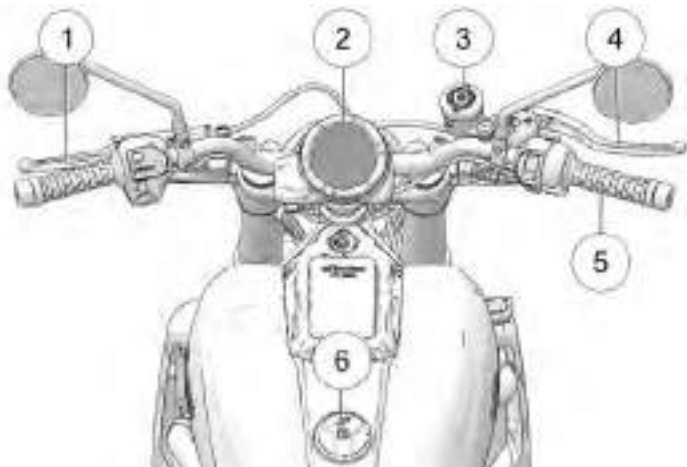



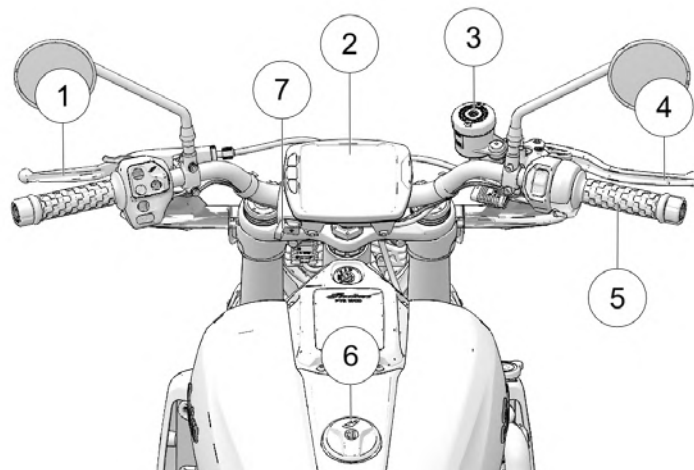

- ① Clutch Lever
- ② Instrument Cluster
- ③ Front Brake Master Cylinder Reservoir
- ④ Front Brake Lever
- ⑤ Electronic Throttle Control
- ⑥ Fuel Cap





FTR S / FTR R CARBON

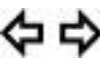

- ① Clutch Lever
- ② Instrument Cluster
- ③ Front Brake Master Cylinder Reservoir
- ④ Front Brake Lever
- ⑤ Electronic Throttle Control
- ⑥ Fuel Cap
- ⑦ USB

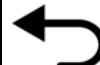
SWITCH SYMBOLS

| SYMBOL | SWITCH | DESCRIPTION |
|---|--|--|
|  | Horn Switch | Press the horn switch to sound the horn. See page 29. |
|  | High Headlight Beam Switch | The high headlight beam switch activates the high headlight beam. See page 30. |
|  | Low Headlight Beam Switch | The low headlight beam switch activates the low headlight beam. Press down momentarily to activate Flash to Pass. See page 30. |
|  | Turn Signal Switch | Move the switch to the left to activate the left turn signals. Move the switch to the right to activate the right turn signals. A signal will deactivate automatically when speed or distance reach predetermined levels. To cancel a signal manually, move the switch to the center position and push it inward. <i>Momentary Feature: Move the turn signal switch left or right and hold it in that position for at least one second. The momentary feature will activate and the signal will then cancel when the switch is released.</i> See page 28. |
|  | Emergency Flasher Switch (Hazard Switch) | The hazard switch activates and cancels the emergency flashers. Press and hold on the center of the switch to activate emergency flashers. See page 28. To activate, move press and hold switch while in the center position until hazards activate. To cancel, press and release switch while in the center position. |

| SYMBOL | SWITCH | DESCRIPTION |
|---|---------------------------|--|
|  | Screen List Select Switch | The Screen List Select Switch (if equipped) is used to navigate through rider screens. See page 39. |
|  | Back Switch (if equipped) | Use the back switch to back out of menus, decline dialog boxes. See page 39. |
|  | Stop Switch | Press the bottom of the switch (RUN) to allow the engine to start and run. Press the top of the switch (STOP) to stop the engine. See page 30. |
|  | Starter Switch | Use the starter switch to start the engine. The engine stop/run switch must be in the RUN position. See page 30. |
|  | Right-Hand Trigger Switch | On models equipped with analog gauge, use the right-hand trigger switch to cycle through the multi-function display. On models equipped with a Ride Command display, use the right-hand switch to navigate through menus. See page 38. |

FEATURES AND CONTROLS

SWITCH LOCATIONS

LEFT CONTROL

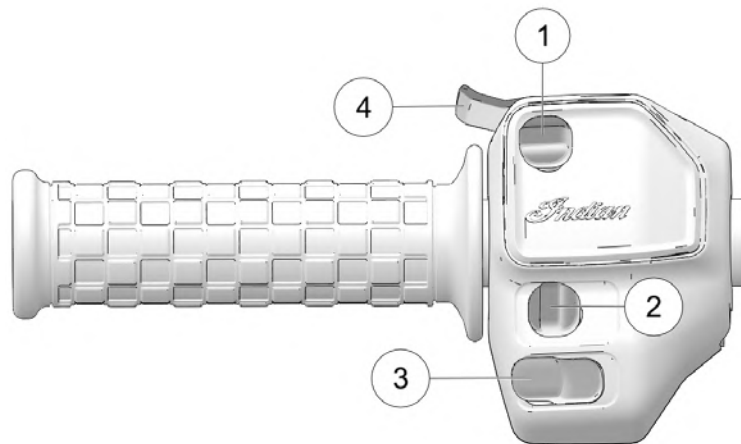

- ① Cruise Control Switch
- ② Turn Signal/Hazard Signal
- ③ Horn Switch
- ④ High/Low Beam and Flash to Pass

RIGHT CONTROL

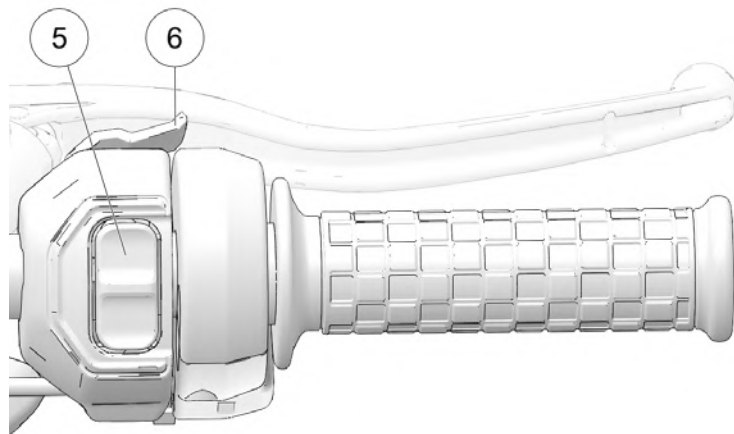

- ⑤ Engine Stop/Run/Start Switch
- ⑥ Right Trigger Switch

SWITCH FUNCTIONS

IGNITION/LIGHT KEY SWITCH

Motorcycle riders must remain as visible as possible at all times. To aid in this, the headlight must be on at all times while operating. The headlights automatically operate when the engine is running. Do not modify the ignition/light switch wiring to circumvent the automatic headlight feature.

The ignition/light key switch controls the electrical functions of the motorcycle. Before starting the engine, read the instructions for starting the engine. See page 68.

NOTICE

Turn the ignition switch to the OFF position, push the key into ignition while turning it to the LOCK position, and remove the ignition key when leaving the motorcycle unattended.

Push the key into the ignition switch while turning it to the PARK position. In PARK, the taillight, front position lamp, indicator lights, and license plate light illuminate. Vehicle powered accessories (if equipped) can be operated and the instrumentation is active. The ignition key can be removed.

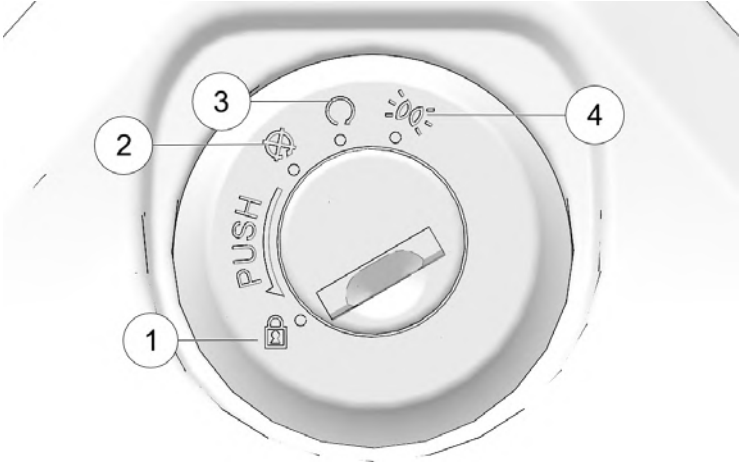

| SYMBOL | DESCRIPTION |
|--------|---------------|
| ① | Steering Lock |
| ② | OFF |
| ③ | RUN |
| ④ | PARK |

FEATURES AND CONTROLS

CRUISE CONTROL SWITCH

Cruise control can be activated and adjusted from the left hand control using the Cruise Control Switch ①.

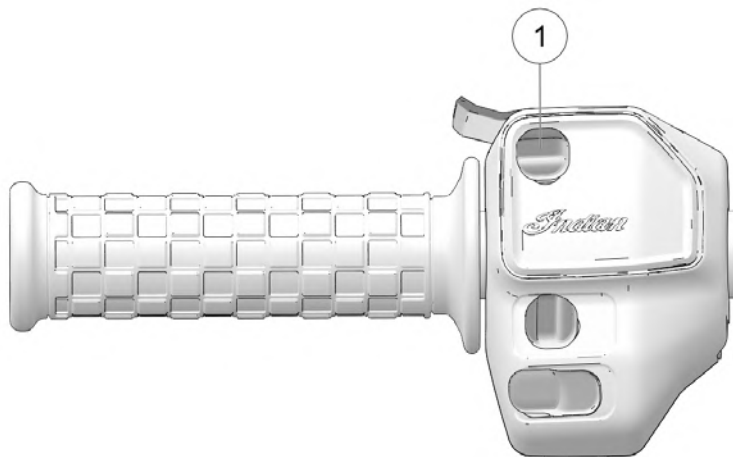

| Toggle Position | Function |
|-----------------|-------------------|
| Down | Set/Decelerate |
| Center | Off/On |
| Up | Resume/Accelerate |

TURN SIGNAL/HAZARD SWITCH

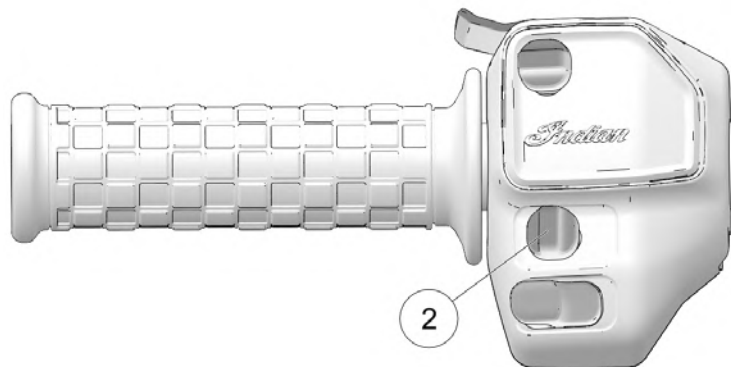

TURN SIGNALS

To activate the turn signal, press the turn signal switch ② in the corresponding direction.

- Press switch to the right to activate the right turn signal.
- Press the switch again to cancel the right turn signal.
- Press switch to the left to activate the left turn signal.
- Press the switch again to cancel the left turn signal.

HAZARD SIGNAL

The ignition switch must be ON to activate the flashers, but once activated, the flashers will continue to flash when the ignition switch is turned to PARK. When the flashers are active, all four turn signals flash.

To activate the hazard signal, press on the center of the turn signal switch ②.

- Press and hold the switch to activate the flashers.
- Press the switch again to cancel the flashers.

HORN BUTTON

Press the horn switch ③ to sound the horn.

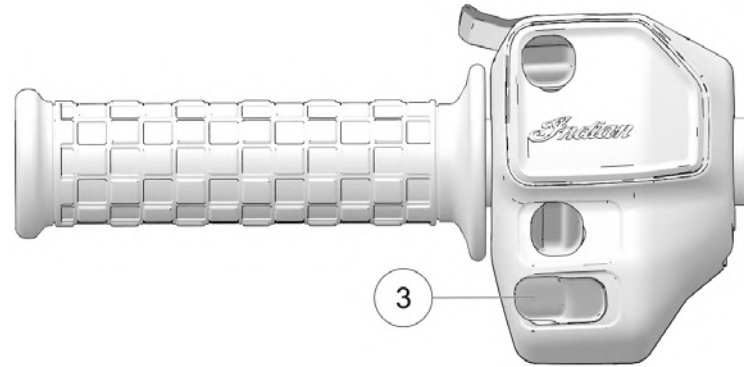

FEATURES AND CONTROLS

ENGINE STOP/RUN SWITCH

Use the engine stop/run switch to turn the engine off quickly. Turn the key off after the engine stops.

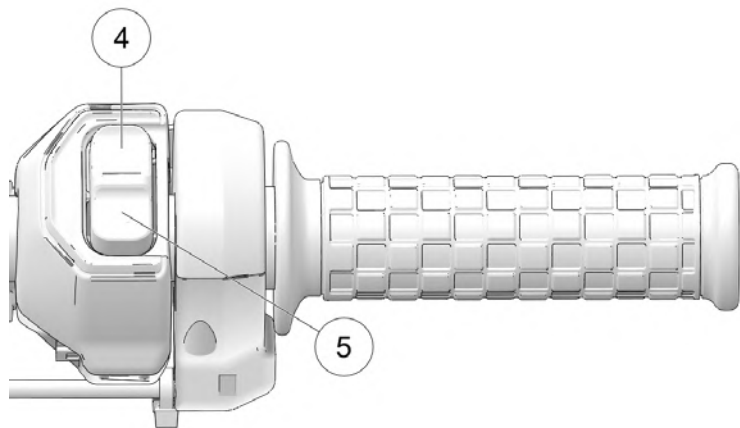

- Press the top of the rocker switch (STOP) ④ to turn the engine OFF.
- Press the bottom of the rocker switch (RUN) ⑤ to start and run the engine.

TIP

The headlight and any accessories plugged into power ports will remain on until the ignition key is turned to the off position.

TRIGGER SWITCHES

All models are equipped with trigger switches on the front side of the left and right handlebar controls ⑥.

NOTICE

The ignition switch must be in the ON position for the trigger switches to function.

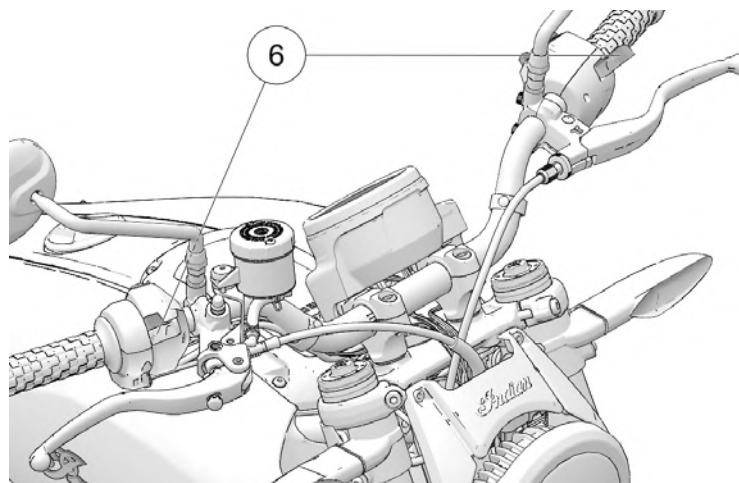

HIGH/LOW HEADLIGHT SWITCH

The headlights automatically come on when the engine is started.

The high/low headlight switch ⑦ toggles the headlight between high beam and low beam. To momentarily flash headlights (Flash to Pass), press and hold the left-hand trigger switch. To activate high beams for an extended period of time, push the trigger forward until it clicks into place. Pull the lever back to the neutral position to return to low beams.

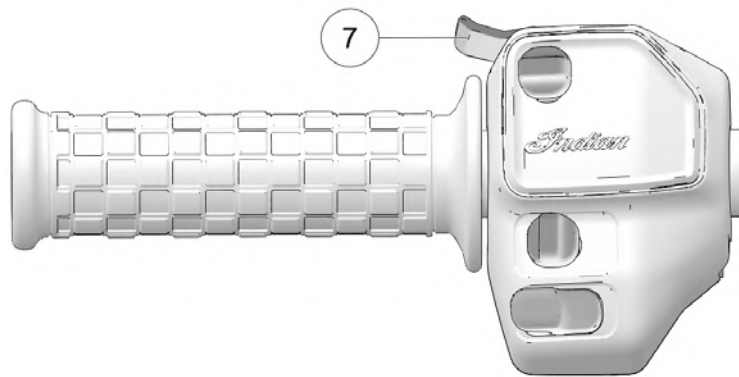

RIGHT-HAND TRIGGER

On models equipped with analog gauge, use the right-hand trigger switch to cycle through the multi-function display. See page 33. On models equipped with a Ride Command display, use the right-hand switch to navigate through menus. See page 38.

INSTRUMENT CLUSTER



The instrument cluster includes the speedometer, indicator lamps and multi-function display (MFD).







| | DESCRIPTION |
|---|------------------------------|
| ① | Speedometer |
| ② | Indicator Lamps |
| ③ | Multi-Function Display (MFD) |



FEATURES AND CONTROLS

SPEEDOMETER



The speedometer displays forward vehicle speed in either miles per hour or kilometers per hour.

INDICATOR LAMPS

| LAMP | INDICATES | CONDITION |
|---|-------------------|--|
|  | Chassis Fault | The alert symbol illuminates if a chassis fault occurs. |
|  | Low Fuel | This lamp illuminates when 0.53 gal (2.0 L) of fuel remains in the tank. |
|  | Neutral | This lamp illuminates when the transmission is in neutral. |
|  | High Beam | The lamp illuminates when the headlight switch is set to high beam. |
|  | Turn Signal | The turn signal indicators flash when the left, right, or both turn signals (hazard) are active. If there is a problem in the signal system, the lamps will flash at twice the normal rate. |
|  | ABS Not Activated | The indicator remains on until the ABS activates, which occurs when vehicle speed exceeds 6 mph (10 km/h). When the lamp is illuminated, the anti-lock brakes will not activate, but the conventional brake system will continue to operate normally. The lamp will also illuminate if an ABS fault is detected. |

| LAMP | INDICATES | CONDITION |
|---|-----------------|---|
|  | Check Engine | <i>If this lamp illuminates while the engine is running, see your dealer promptly.</i> The light will remain on if the tilt sensor shuts down the engine. If abnormal sensor or engine operation is detected the light will remain on as long as the fault condition exists. Retrieve the error codes for diagnosis. If a misfire is detected, the check engine lamp will begin to flash and fuel will be cut to the affected cylinder(s). See page 36. |
|  | Engine Overheat | The engine overheat light will illuminate when the engine temperature exceeds normal operating temperature. |

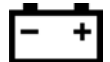
MFD TELL-TALES

| LAMP | INDICATES | CONDITION |
|---|-----------------------|---|
|  | Low Oil Pressure | The Low Oil Pressure lamp illuminates when oil pressure drops below a safe operating pressure while the engine is running. If this lamp illuminates while the engine is running above idle speed, turn the engine off as soon as safely possible and check the oil level. <i>If the oil level is correct and the lamp remains on after the engine is restarted, turn the engine off immediately. See your dealer.</i> |
|  | Battery Voltage | The Battery Voltage lamp illuminates if high or low battery voltage is detected, or if there is a charging system fault. Turn non-essential accessories off to conserve power. Make sure the charging system is operating properly. See page 145. |
| MPH | Vehicle Speed | When standard mode is selected, speed displays in miles per hour. |
| km/h | | When metric mode is selected, speed displays in kilometers per hour. |
|  | Cruise Control Status | When the <i>Dial Icon</i> is visible, cruise control is enabled, but not set. The <i>Arrow Icon</i> becomes visible when cruise control is set to the desired speed. <i>Read the safety and operation procedures before using cruise control. See page 73.</i> |

MULTI-FUNCTION DISPLAY MODES

With the ignition switch on, use the right-hand trigger switch to toggle through the modes of the multi-function display and to change settings in the display.

The following display modes are available:

- Odometer
- Trip Odometer
- Trip Odometer 2
- Engine Speed
- Gear Indicator
- Battery Voltage
- Engine Error Codes
- Average Fuel Economy
- Instant Fuel Economy
- Ambient Air Temperature

ODOMETER

The odometer displays total distance traveled.

TRIP ODOMETER

The trip odometer displays total distance traveled since being reset. To reset, toggle to the trip odometer, then press and hold the MODE button until the trip odometer resets to zero.

ENGINE SPEED

Engine speed displays in revolutions per minute (RPM).

FEATURES AND CONTROLS

GEAR INDICATOR

The vehicle's current gear position is displayed on the MFD.

BATTERY VOLTAGE

Battery voltage displays real-time, regulated charge voltage supplied to the battery. The voltage level may fluctuate depending on electrical load and engine RPM.

AVERAGE FUEL ECONOMY

Average Fuel Economy displays the vehicle's average fuel economy as of the last time the mode was reset. To reset, press and hold the right hand trigger while viewing the fuel economy display.

INSTANTANEOUS FUEL ECONOMY

Instantaneous Fuel Economy displays the vehicle's current fuel economy at the moment the mode was selected.

AMBIENT AIR TEMPERATURE

The temperature area displays the temperature of the air immediately surrounding the motorcycle.

DISPLAY UNITS (STANDARD/METRIC)

The display can be changed to display either standard or metric units of measurement.

| | STANDARD DISPLAY | METRIC DISPLAY |
|-------------|------------------|--------------------------|
| Distance | Miles | Kilometers |
| Temperature | Fahrenheit | Celsius |
| Time | 12-Hour Clock | 24-Hour Clock |
| Volume | Gallons | Imperial Gallons, Liters |

1. Turn the ignition off.
2. Wait 10 seconds.
3. Press and *hold* the right-hand trigger switch while turning the key to the ON or PARK position.
4. When the display flashes the distance setting, tap the right-hand trigger switch to advance to the desired setting.
5. Press and *hold* the right-hand trigger switch to save the setting and advance to the next display option.
6. Repeat the procedure to change remaining display settings.

CLOCK

NOTICE

The clock must be reset any time the battery has been disconnected or discharged.

1. Use the right-hand trigger switch to toggle to the odometer display.
2. Press and *hold* the right-hand trigger switch until the hour segment flashes. Release the switch.
3. With the segment flashing, tap the right-hand trigger switch to advance to the desired setting.
4. Press and *hold* the right-hand trigger switch until the next segment flashes. Release the switch.
5. Repeat steps 3–4 twice to set the 10-minute and 1-minute segments. After completing the 1-minute segment, step 4 will save the new settings and exit the clock mode.

3. Record the three numbers displayed in the gear position, clock and odometer displays.
4. See an authorized dealer for code details and diagnosis.



- ① Error Code Number (0–9)
- ② Suspect Parameter Number (SPN)
- ③ Failure Mode Indicator (FMI)

ENGINE ERROR CODES

The error screen displays only when the CHECK ENGINE light is on or when it goes on and off during one ignition cycle. Error codes display only during the current ignition cycle. When the ignition switch is turned OFF, the code and message is lost, but will reappear if the fault reoccurs after restarting the engine.

If the CHECK ENGINE indicator lamp illuminates, retrieve the error codes from the display.

1. If the error codes are not displayed, use the right-hand trigger switch to toggle until “Ck ENG” displays on the main line of the display.
2. Press and hold the right-hand trigger switch to enter the diagnostics code menu.

FEATURES AND CONTROLS

DIAGNOSTIC FUNCTIONALITY

Certain conditions will cause the battery indicator to illuminate and an error message to display in the screen. If this occurs, please see your authorized dealer.

| MESSAGE | LOCATION | INDICATES |
|---------|-------------------|---|
| LO | DC Voltage Screen | Voltage remains below 11.0 volts for more than 10 seconds |
| OV | DC Voltage Screen | Voltage remains above 15.0 volts for more than 10 seconds |
| ERROR | All | Checksum error (gauge malfunction) |

OVER TEMPERATURE DISPLAY AND WARNING INDICATOR

Engine Over Temperature indicator lamp illuminates and the actual engine coolant temperature displays on the multi-function display (MFD) under the following conditions.

| CONDITION | INDICATES | ACTION REQUIRED |
|---|---|--|
| Engine coolant temperature approaches unsafe operating condition while the engine is running. | Engine coolant temperature is above a safe operating temperature. | Stop the engine as soon as safely possible. Check the coolant level. Check the radiator for debris. Check cooling fan operation. If the warning continues to display after restarting the engine, stop the engine immediately. |

MISFIRE DETECTION

If a misfire is detected, the check engine indicator lamp will begin to flash and fuel will be cut to the affected cylinder(s). The check engine indicator lamp will continue to flash until the ignition switch has been moved to the off position. Restarting the engine will clear the flashing indicator and restore fuel to both cylinders. If another misfire occurs, the check engine indicator lamp will resume flashing and fuel will once again be cut to the affected cylinder(s). After the 3rd misfire, P0314 misfire fault is determined and set, the check engine light will remain on and fuel will be cut to the affected cylinder(s). If this occurs, your INDIAN MOTORCYCLE dealer can assist.

REAR CYLINDER DEACTIVATION

Designed as an aid to reduce engine and exhaust heat to the rider, Rear Cylinder Deactivation shuts down the rear cylinder when the engine is at operating temperature and at idle speed.

The following condition must be met for Rear Cylinder Deactivation to be enabled.

- Engine coolant temperature must be above 176 °F (80 °C)
- Ambient Temperature must exceed 59 °F (15 °C)
- Engine speed must be below 2200 rpm
- Throttle must be in the closed position (0% throttle)

FOR MODELS EQUIPPED WITH RIDE COMMAND

Rear Cylinder Deactivation can be turned on and off by accessing the settings menu. Cylinder Deactivation controls are in the Vehicle Settings menu. When Rear Cylinder Deactivation is functioning, an icon will illuminate at the right of the Ride Command display screen.

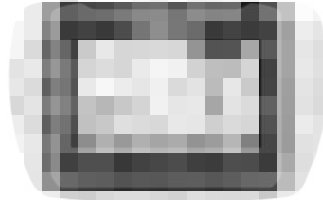

FOR MODELS NOT EQUIPPED WITH RIDE COMMAND

Perform the following procedure to enable or disable Rear Cylinder Deactivation:

1. Navigate to the ambient air temperature display mode on the multi-function display (MFD).
2. Long press the right-hand trigger until “CYLdeAC” displays.
3. Pressing the right-hand trigger will allow operator to toggle between “CD ON” or “CD OFF.”
4. Press and hold hand right-hand trigger to save settings.
 - CYLdeAC ON: rear cylinder can deactivate
 - CYLdeAC OFF: rear cylinder cannot deactivate

When the cylinder deactivation feature activates and the cylinder is deactivated, a “CylDeAc” message is shown on the MFD for 1 second. When the feature deactivates and the cylinder activates, a “CylAc” message is shown on the MFD for 1 second.

RIDE COMMAND DISPLAY (IF EQUIPPED)



For the latest information about your Ride Command display, including software updates, please visit: <https://ridecommand.indianmotorcycle.com>

WARNING

Do not enter information while operating your vehicle. Failure to pay attention to operating your vehicle could result in loss of control, serious injury, or death. You assume all risks associated with using this device. Read your User Guide.

FEATURES AND CONTROLS

WARNING

Driving while distracted can result in loss of vehicle control, crash, and serious injury. We strongly recommend that you use extreme caution when using any device that may take your focus off the road. Your primary responsibility is the safe operation of your motorcycle. We recommend against the use of any hand-held device while driving and encourage the use of voice-operated systems when possible. Make sure you are aware of all applicable local laws that may affect the use of electronic devices while driving.

Before riding with your new display, do the following:

- Read this entire manual.
- Familiarize yourself with the features and operations of the display while the vehicle is stationary.
- Download the Indian Motorcycle Ride Command app from the Apple® App Store®/Google Play™ store and create your personalized account.
- Check <http://www.polaris.com/en-us/rider-support/owners-manual> for the latest updates to the owner's manual.

NOTICE

Using the display for an extended period of time while the vehicle's engine is off can drain the battery.

RIDE COMMAND HAND CONTROLS

RIGHT TRIGGER

Press the right-hand trigger switch ① to toggle through the Ride Command display screens.

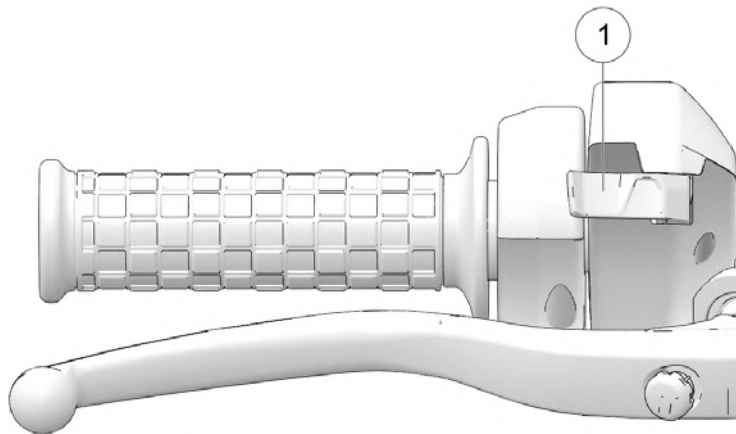

SELECT JOYSTICK

The 5-way Select Joystick ② allows you to navigate through the display screen from the left-hand switch cube.

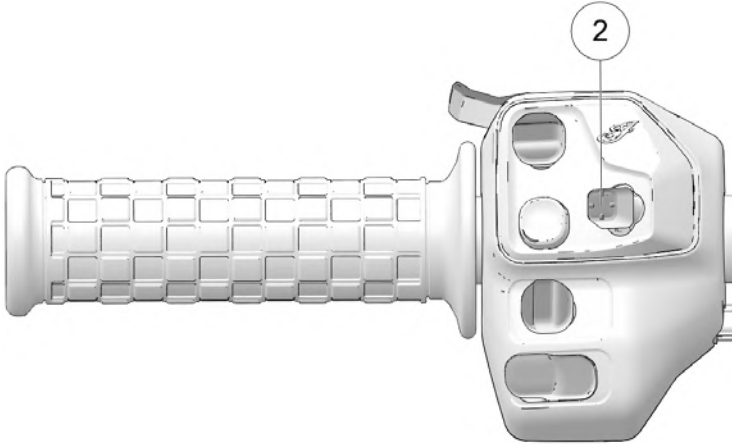

Use the 5-way select joystick to do the following:

- Long press to show App Tray
- Navigate through menu gauge/menu screens
- Enter/Select
- Change gauge style

BACK BUTTON

Press the back button ③ to do the following:

- Close Pop-ups
- Navigate back in menu
- Long press to return to gauges screen
- When viewing a top-level display screen, press the back button to cycle through the Ride Command display screens.

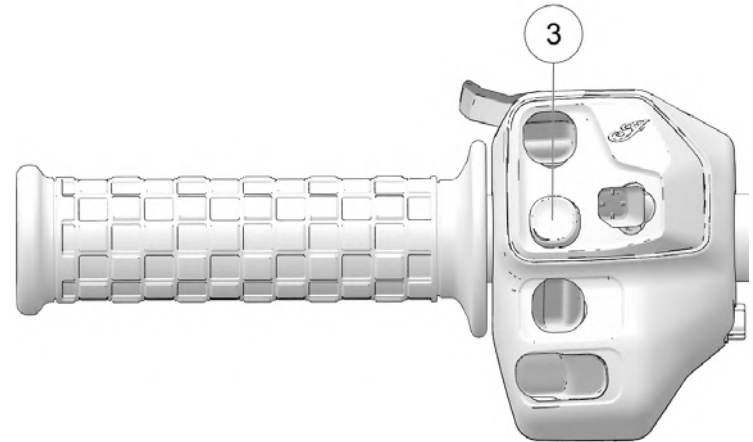

FEATURES AND CONTROLS

RIDE COMMAND DISPLAY SCREENS



The Ride Command display has four top-level display screens:

- Gauge Screen
- Music Screen
- Phone Screen
- App Tray

To cycle through the display screens, do one of the following:

- Press the physical up ① or down ② button on the gauge.
- Press the right trigger switch.
- While viewing one of the four top-level screens, press the back button on the left hand control.

GAUGE SCREEN



The gauge screen displays the vehicle's speed, current gear, fuel level and range, ambient and engine temperature, odometer, trip meter, and compass. You have two different gauge styles to choose from, round or linear (both shown above). The display style can be changed by swiping up or down on the touchscreen, or by pressing up or down on the select joystick.

MUSIC SCREEN

The music screen allows you to access music stored on your smartphone or other music device. You can pair your device using Bluetooth®, or by connecting it to the display's USB port.

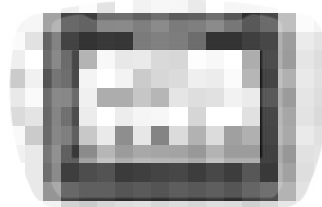

USB audio playback is only available on flash drives formatted to ex-FAT or FAT32. Playback from an iOS® device is only available on iPhone® 5S models or later.

PHONE SCREEN

The phone screen displays recent calls, contact list, key pad, and messages. The display will only show messages received while smart-phone is paired via Bluetooth®.

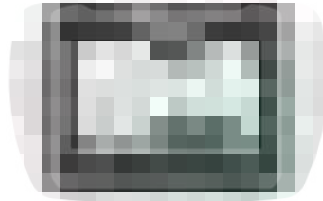



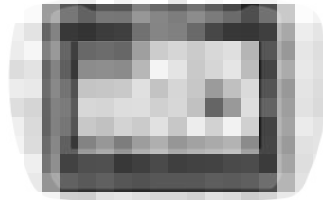

APP TRAY

From the App Tray you can access settings, adjust display brightness, select ride mode, and enable/disable ride mode.





You can access the App Tray at anytime by pressing the center button on the gauge or a long press of the select joystick.



RIGHT SIDE MENU BAR INDICATORS

| LAMP | INDI-CATES | CONDITION |
|---|------------------|---|
|  | Engine Overheat | The engine overheat symbol will illuminate when the engine temperature exceeds normal operating temperature. |
|  | Battery Warning | The Battery Voltage lamp illuminates if high or low battery voltage is detected, or if there is a charging system fault. Turn non-essential accessories off to conserve power. Make sure the charging system is operating properly. |
|  | Low Oil Pressure | The Low Oil Pressure lamp illuminates when oil pressure drops below a safe operating pressure while the engine is running. If this lamp illuminates while the engine is running above idle speed, turn the engine off as soon as safely possible and check the oil level. <i>If the oil level is correct and the lamp remains on after the engine is restarted, turn the engine off immediately. See your dealer.</i> |
|  | Sidestand | The side-stand symbol illuminates if the side-stand is in the extended position. |

FEATURES AND CONTROLS

| LAMP | INDICATES | CONDITION |
|--|----------------------------|---|
|  | Cruise Control Status | <i>Amber Lamp:</i> Cruise control is enabled, but not set. When flashing, a cruise control related fault exists. <i>Green Lamp:</i> Cruise control is set to the desired speed. <i>Read the safety and operation procedures before using cruise control. See page 73.</i> |
|  | Traction Control Fault | The traction control fault indicator remains on until the traction control system activates, which occurs when vehicle speed exceeds 6 mph (10 km/h). The traction control fault indicator also illuminates when the traction control system has experienced abnormal operation and will remain on as long as the fault condition exists. |
|  | Traction Control Off | The traction control off symbol illuminates when the traction control system is off. See page 43. |
|  | Rear Cylinder Deactivation | Designed as an aid to reduce engine and exhaust heat to the rider, Rear Cylinder Deactivation shuts down the rear cylinder when the engine is at operating temperature and at idle speed. See page 36. |

RIDE COMMAND RIDE MODES



You can choose between three ride modes, Rain, Standard, or Sport, for an experience customized to your riding style. The throttle map for each ride mode was designed with a specific application in mind, resulting in one motorcycle with three distinct personalities.

NOTICE

For the ride mode to change the throttle must be fully disengaged. If you change the ride mode while the throttle is engaged, a spinning icon will appear indicating that the ride mode has not yet changed. Once the throttle has been disengaged the icon will disappear and the ride mode will change.

RAIN

Rain mode is ideal for rainy conditions, or when the road is wet. The throttle response is decreased, giving you more control and traction.

STANDARD

Standard mode features a crisp throttle response and well-balanced power delivery for responsive passing power and predictable, slow-speed handling.

SPORT

Sport mode is designed for situations when instant response is needed. Sport mode quickens the throttle response and has a more aggressive power delivery for increased acceleration.

TRACTION CONTROL



To disable the traction control, do the following:

FEATURES AND CONTROLS

1. Tap on the Traction Control toggle switch to disable traction control.
2. A prompt will appear asking you to confirm that you want to disable the Traction Control System. Press **DISABLE** to confirm.

NOTICE

If the traction control is disabled while the throttle is engaged, the traction control will stay active until the throttle has been disengaged.

3. To re-enable traction control, press the Traction Control toggle switch again.

RIDE COMMAND SETTINGS

From the Settings Menu you can view important details about your vehicle and personalize your touchscreen display. The settings menu is comprised of four categories: Information, General, Time, and Vehicle.

GENERAL INFORMATION

From the Information settings menu you can view the following:

- Vehicle Identification Number (VIN)
- Mileage
- Installed Software Version
- Oil Change Interval

GENERAL SETTINGS

From the General settings menu you can do the following:

- Themes (Day/Night/Auto)
- Manage Bluetooth® Devices
- Change the Language
- Set the Speed Units of Measure (MPH or KPH)
- Set the Temperature Units (F or C)
- Update Software

CLOCK

From the Time Settings you can do the following:

- Set the Time Format (12 hour or 24 hour)
- Enable GPS Time (automatically sets the time to the time zone you are currently in)
- Set Time (if GPS Time is not enabled)

VEHICLE INFORMATION

From the Vehicle Settings you can do the following:

- Oil Life/ Service Reset
- Access Vehicle Diagnostics
- Activate/Deactivate Cylinder Deactivation

BLUETOOTH® PAIRING

The Ride Command touchscreen display can be connected to a smart-phone and a headset simultaneously.

To pair a device, do the following:

1. From the Bluetooth® Devices settings screen, the Phone screen, or the Music screen, tap on the Add Device button to bring up the pairing prompt.
2. Put your Bluetooth® device into pairing mode.
3. Select the name of the device you want to pair from the touchscreen display to finish the pairing process.
4. Confirm pairing (if applicable). Depending on the device you are pairing to the display you may be prompted to confirm pairing.

UPDATE SOFTWARE

For the latest software for RIDE COMMAND, go to:
<https://ridecommand.indianmotorcycle.com>.

The display software can be updated by connecting a USB stick containing the latest software version to the USB port located on the bottom left of the display. The Update Software menu in Settings will list any available updates on the USB stick. Choose the correct version and wait for the update to complete before removing the USB stick. The touchscreen display will automatically restart when software is updated.

NOTICE

A USB 2.0 or USB 3.0 flash drive formatted to ex-FAT or FAT32 is required to successfully perform an update. The display will not recognize flash drives that do not meet these requirements.

IMPORTANT

Do not remove power from the display during the update process.

FEATURES AND CONTROLS

USB PORT (IF EQUIPPED)

The USB Port makes it easy to power devices, such as phones, audio sources, or GPS units, in addition to allowing you to stream music through the LCD display to your Bluetooth® headset. On models equipped with a INDIAN MOTORCYCLE Ride Command display, the USB port is also used to update the display software. For the latest software, go to <https://ridecommand.indianmotorcycle.com>.

IMPORTANT

Due to harsh riding environments, INDIAN MOTORCYCLE recommends using a USB device with retention features.

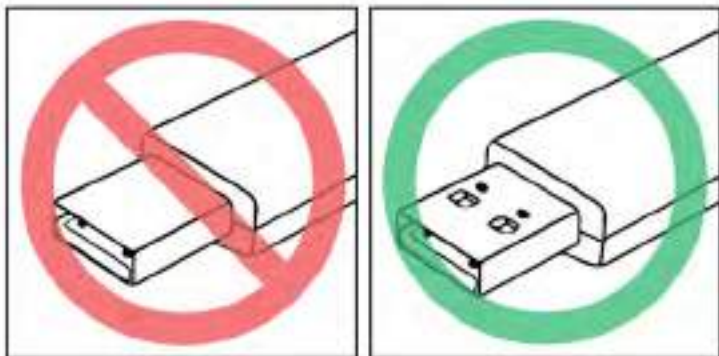

THROTTLE CONTROL GRIP

The throttle control grip is located on the right handlebar. Use the throttle control grip to control engine speed.



While seated in the proper riding position:

- Roll the grip rearward ① to open the throttle (increase engine speed and power).
- Roll the grip forward ② to close the throttle (decrease engine speed and power).
- Roll the grip forward, past idle position, to cancel cruise control.

The control grip is spring loaded. When you release the grip, the throttle returns to the idle position.

GEAR SHIFT LEVER

The gear shift lever ③ is located on the left side of the motorcycle. Operate the lever with your foot.

- Press downward on the toe lever to shift to a lower gear.
- Lift upward on the toe lever to shift to a higher gear.
- Release the lever after each gear shift.
- See page 69 for gear shifting procedures.



CLUTCH LEVER

The clutch lever ④ is located on the left handlebar. Disengage the clutch before shifting gears. For smooth clutch operation, pull the lever quickly and release it in a brisk but controlled manner.

- To disengage the clutch, pull the lever toward the handlebar.
- To engage the clutch, release the lever in a brisk but controlled manner.

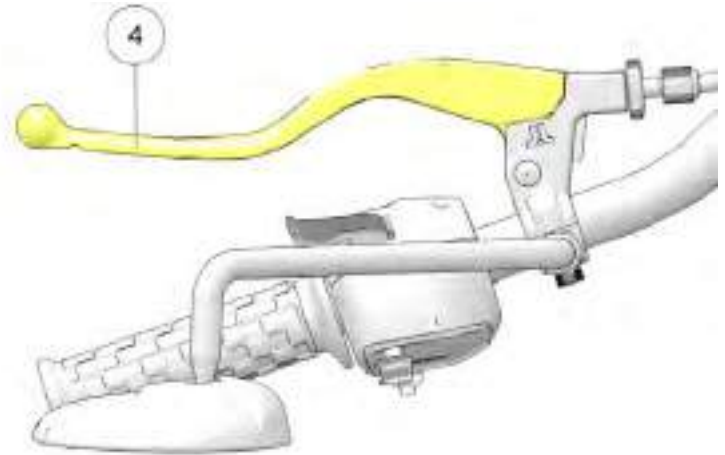

FEATURES AND CONTROLS

SIDE-STAND

The FTR is equipped with a side-stand safety switch to prevent operation of the motorcycle if the side-stand is deployed.

WARNING

An improperly retracted side-stand could contact the ground and cause a loss of control resulting in serious injury or death. Always retract the side stand fully before operating the motorcycle.

To park the motorcycle, swing the end of the side-stand downward and away from the motorcycle until it is fully extended. Always turn the handlebars to the left for maximum stability. Lean the motorcycle to the left until the side-stand firmly supports the motorcycle.

CAUTION

If the motorcycle weight is not resting on the side-stand, it will not lock. In this situation, any movement of the motorcycle could cause the side stand to retract slightly. If the side-stand is not in the full forward position when the motorcycle weight is rested on it, the motorcycle could fall over, possibly causing personal injury and damage to the motorcycle.

To retract the side-stand, straddle the motorcycle and bring it to the fully upright position. Swing the end of the side-stand upward and toward the motorcycle until it is fully retracted.

See page 74 for parking instructions, including parking on slopes and soft surfaces.

WARNING

Do not sit on the motorcycle when it is supported on the side-stand.

FEELER PEGS

Your bike is equipped with small feeler pegs extending from the end of both footpegs to help protect against damage. Once either feeler peg has been eroded up to the hex portion, a replacement feeler peg is recommended.

WHEELIE MITIGATION

Wheelie mitigation is a feature that allows maximum acceleration while keeping the front wheel on or near the ground. The feature is active when the vehicle is in "Rain" or "Standard" ride modes, but not when the vehicle is in 'Sport' mode or the TC system is disabled.

NOTICE

The wheelie mitigation feature cannot prevent the front wheel from losing contact with the ground in all situations.

- If the wheelie mitigation feature is disabled and the front wheel loses contact with the road surface long enough to become stationary, a wheel speed sensor fault may be set.
- If a fault code is set, the TC system will become deactivated and the display will illuminate the MTC lights. If this occurs, a power cycle will be required to re-initialize the MTC system.

MIRRORS

Your vehicle is equipped with convex mirrors. Objects seen in a mirror may be closer than they appear. Always adjust mirrors before riding.

To adjust the mirrors, sit on the motorcycle in the anticipated riding position. Adjust the mirrors so that you can see a small portion of your shoulders in each mirror.

BRAKES

ANTI-LOCK BRAKE SYSTEM (ABS)

The anti-lock brake system automatically reduces brake pressure as needed to provide optimum braking control, reducing the chance of wheel lock-up during hard braking events or when braking on rough, uneven, slippery or loose surfaces. See the Safe Riding Practices starting page 11.

1. The ABS indicator always illuminates when vehicle power is turned on. It remains illuminated until the anti-lock system activates, which occurs when vehicle speed exceeds 6 mph (10 km/h).
2. When the lamp is illuminated, the anti-lock brakes will not activate, but the conventional brake system will continue to operate normally.
3. When the anti-lock brakes engage during a braking event, the rider will feel pulsing at the brake levers. *Continue to apply steady pressure to the brakes for the best stopping performance.*
4. If the ABS light does not come on when the key is turned to the ON or PARK position, see your authorized INDIAN MOTORCYCLE dealer for service.
 - If the lamp continues to illuminate after vehicle speed exceeds 6 mph (10 km/h), the ABS system is not functioning. See your INDIAN MOTORCYCLE dealer promptly for service.
 - Operating with non-recommended tires or improper tire pressure may reduce the effectiveness of the anti-lock brake system. Always use the recommended size and type of tires specified for your vehicle. Always maintain the recommended tire pressure.
 - The anti-lock brake system will not prevent wheel lockup, loss of traction or loss of control *under all conditions*. Always adhere to all safe motorcycle-riding practices as recommended.
 - It is not unusual to leave tire marks on the road surface during a hard braking event.
 - The anti-lock brake system does not compensate for or reduce the risks associated with:
 - excessive speed
 - reduced traction on rough, uneven or loose surfaces
 - poor judgment
 - improper operation

FEATURES AND CONTROLS

FRONT BRAKE LEVER

The front brake lever ⑤ is located on the right handlebar. This lever controls only the front brakes. The front brakes should be applied simultaneously with the rear brakes. To apply the front brake, pull the lever toward the handlebar. See page 72 for braking procedures.

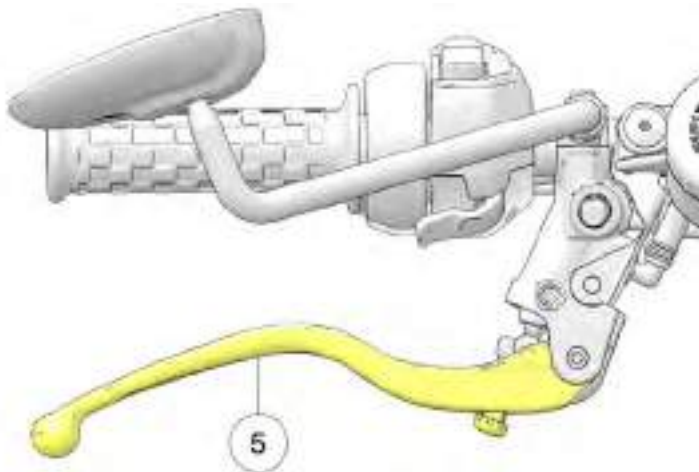

REAR BRAKE PEDAL



Resting your foot on the brake pedal will cause excessive and premature wear of brake pads and reduced braking efficiency, which could result in serious injury or death.

The rear brake pedal ⑥ is located on the right side of the motorcycle. Press downward on the rear brake pedal to apply the rear brake. See page 72 for braking procedures.

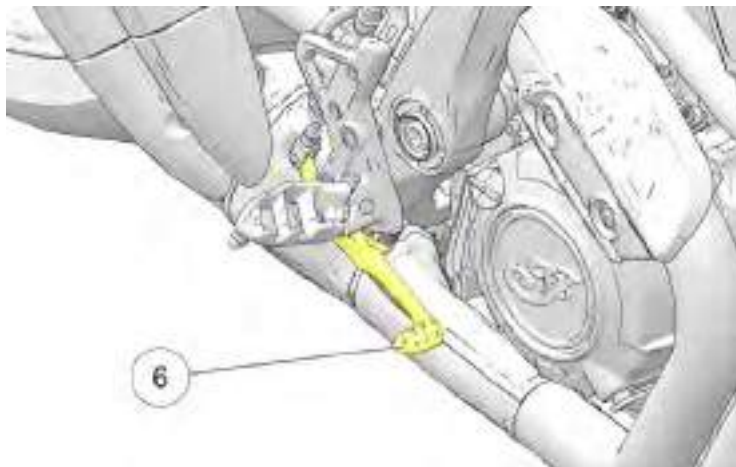

REAR BRAKE PEDAL FREEPLAY**⚠ WARNING**

Free travel must be present on the brake pedal lever or pressure could build up in the rear brake system causing overheating and failure. The brake pedal free travel ⑦ is adjusted at the factory and must always be set in accordance with the specification. Changing this adjustment could cause brake damage or failure. If adjustments are needed, see your dealer.

MEASUREMENT

Free travel at brake lever peg:
.019–.276 in (3–7 mm)

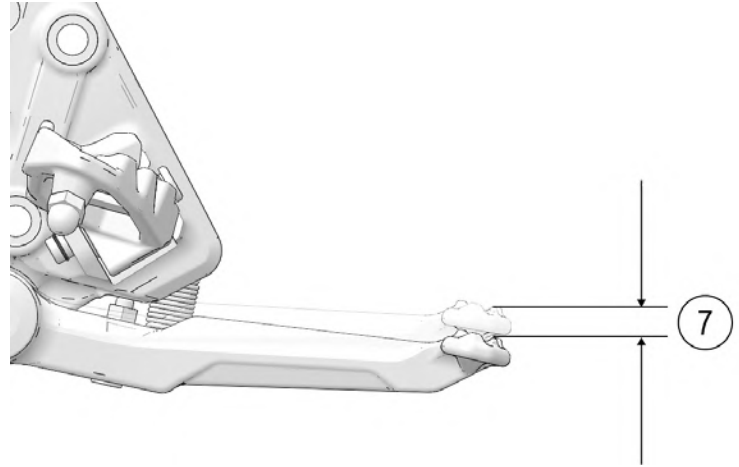

PRE-RIDE INSPECTIONS OVERVIEW

To keep your motorcycle in safe operating condition, always perform the recommended pre-ride inspections before each ride. This is especially important before making a long trip and when removing the motorcycle from storage.

WARNING

Failure to perform the recommended pre-ride inspections could result in component failure while riding, which could result in serious injury or death. Always perform the pre-ride inspections before each ride. When inspection reveals the need for adjustment, replacement or repair, perform the service promptly, or see your authorized INDIAN MOTORCYCLE dealer or other qualified dealer for service.

WARNING

Read the entire Instruments, Features and Controls section of this manual before riding your motorcycle. A complete understanding of the features and capabilities of your motorcycle is essential to its safe operation. Anything less may result in serious injury or death.

You must be familiar with all instruments and controls to perform the pre-ride inspections.

NOTICE

During the pre-ride inspections you may use products that are potentially hazardous, such as oil or brake fluid. When using any of these products, always follow the instructions and warnings on the product packaging.

When inspections reveal the need for adjustment, replacement or repair:

- refer to the maintenance section of this manual
- refer to the INDIAN MOTORCYCLE Service Manual
- or see your authorized INDIAN MOTORCYCLE dealer or other qualified dealer

PRE-RIDE INSPECTIONS

ELECTRICAL INSPECTIONS

Turn the ignition key to the ON position and move the stop/run switch to RUN before performing the following electrical inspections. Return the ignition key to the OFF position after completing these inspections. If inspection of any electrical item reveals component failure, repair or replace the component before operating the motorcycle.

| ITEM | INSPECTION PROCEDURE |
|--------------------------|---|
| Headlight | Start engine to activate headlights. Once headlamp illuminates, switch to high beam. Verify that the high beam indicator comes on and that lamp brightness increases. |
| Taillight/ Brakelight | Verify that the taillight and license plate light illuminate. Verify that the taillight lamps increase in brightness when the front brake lever is applied and also when the rear brake pedal is applied. |
| Turn Signals | Move the turn signal switch to the left. Verify that front and rear left turn signals flash, as well as the corresponding light on the indicator panel. Move the switch to the center position and push it inward to cancel the signal. Verify that the signals and the indicator light stop flashing. Repeat the procedure for the right turn signals. |

| ITEM | INSPECTION PROCEDURE |
|----------------------------|---|
| Hazard Warning Flashers | Press and hold the hazard warning flashers switch for 1-2 seconds to activate the hazard warning flashers. Verify that all four turn signals flash, as well as the lamps on the indicator panel. Turn the hazard warning flashers off. Verify that all signals and indicator lamps stop flashing. |
| Horn | Press the horn switch. Verify that the horn sounds loudly. |
| Neutral Indicator | Place the transmission in neutral. Verify that the neutral indicator lamp illuminates and that the letter "N" displays in the gear position display. |
| Low Oil Pressure Indicator | Start the engine. Verify that the low oil pressure indicator is not illuminated. |
| Engine Stop/ Run Switch | Start the engine. Move the stop/run switch to the STOP position. Verify that the engine stops. |

GENERAL INSPECTIONS

| ITEM | INSPECTION PROCEDURE |
|--------------------|---|
| Engine Oil | Check the oil level. |
| Fuel | Check the fuel level |
| Coolant Level | Check the coolant level in the recovery bottle. |
| Fluid Leaks | Check the vehicle and the ground/floor for any fuel, oil, coolant or hydraulic fluid leaks. |
| Tires | Inspect condition, pressure and tread depth. |
| Brake Operation | Inspect pedal and lever movement. |
| Brake Fluid Levels | Check front and rear brake fluid levels. |
| Brake Components | Inspect hoses and connections. |
| Throttle | Inspect hand grip and throttle movement. |
| Clutch | Check lever operation and freeplay. |
| Front Suspension | Check for leaks, debris and damage. |
| Steering | Check for smooth operation by turning handlebars full left and full right. |

| ITEM | INSPECTION PROCEDURE |
|------------------|--|
| Rear Suspension | Check mounting and inspect for leaks. |
| Rear Drive Chain | Check for wear or damage. |
| Side Stand | Verify smooth operation, inspect pivot bolt and spring. |
| Fasteners | Inspect for loose, damaged or missing fasteners. |
| Mirrors | Adjust for proper rear view. |
| Heat Shields | Ensure all exhaust heat-shields are present and in good condition. |

PRE-RIDE INSPECTIONS

ENGINE OIL LEVEL CHECK

Due to the semi-dry sump lubrication system, the engine oil level shown in the sight glass will fluctuate with movement of the motorcycle from a vertical position and with the temperature of the oil. To get an accurate oil level reading follow all inspection procedures closely.

IMPORTANT

Engine **MUST BE AT OPERATING TEMPERATURE** when checking oil level. Check oil after riding or after idling a cold engine for 5-10 minutes.

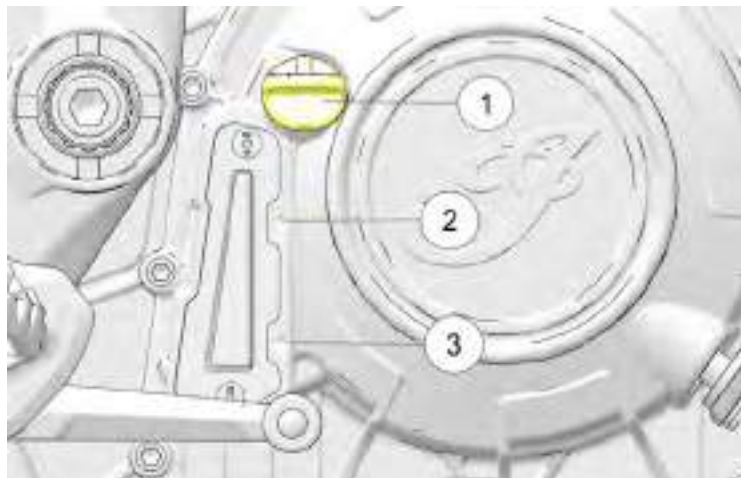

1. With the motorcycle in an upright (vertical) position, let the warm engine idle for 30 seconds.
2. Stop engine.
3. Place the machine on a level area and hold it in an upright (centered) position.
4. Inspect the oil level by looking at the oil sight glass. The oil level should be in the middle of the sight glass between the FULL ② and ADD ③ marks.
5. Do not overfill. The appropriate volume of oil should be in the middle of the sight glass. If oil level is low, remove engine oil fill plug ① and add Indian Motorcycle 15W-60 Full Synthetic engine oil. Repeat steps 1- 4 until the reading is within the safe operation range.

⚠ CAUTION

Oil level will **NOT** be accurate if checked on a cold engine. **DO NOT ADD** oil to raise level to middle of sight glass on a cold engine, as this can result in overfilling.

NOTICE

Do not overfill! The correct approximate volume is in the middle of the sight glass between the FULL and ADD marks.

TIRES



WARNING

Operating the motorcycle with incorrect tires, incorrect tire pressure or excessively worn tires could cause loss of control or serious injury. Underinflation can cause a tire to overheat and result in a tire failure. Only use tires approved by INDIAN MOTORCYCLE for the model of the motorcycle. See your dealer. Use of unapproved or an improperly mixed front and rear tire can result in decreased handling performance and stability, potentially leading to reduced control of the motorcycle. Always maintain proper tire pressure as recommended in the rider's manual and on safety labels.

TIRE PRESSURE

Improper tire pressure can result in irregular tire wear, tire failure, reduced fuel economy and a poor riding experience. It can also affect handling and stopping ability.

Slow tire pressure loss over time is normal for a functional tire. Always inspect tire pressure and condition before each ride.

Check tire pressure before riding, when the tires are cold. This will provide the most accurate reading, as riding warms the tires and increases tire air pressure. Tires remain warm for at least 3 hours after a ride. Do not adjust tire pressure immediately after riding. As tires cool, the pressure will drop and result in underinflation. Always check and adjust tire pressure when tires are cold.

Using a good quality pocket-style gauge, adjust tire pressure to the recommended pressure.

TIRE CONDITION

Inspect the tire sidewalls, road contact surface and tread base. If inspection reveals cuts, punctures, cracks or other wear or damage, replace the tire before riding. Only use tires approved by INDIAN MOTORCYCLE for the model of the motorcycle. See your dealer. Use of unapproved or an improperly mixed front and rear tire can result in decreased handling performance and stability, potentially leading to reduced control of the motorcycle.

TIRE TREAD DEPTH

Measure the tread depth near the center of the tread on both tires. See page 130. Replace any tire with a tread depth of less than 1/16 in (1.6 mm).

BRAKE FLUID LEVEL INSPECTION

IMPORTANT

The brake fluid level in the reservoir will go down as brake pads wear. If you notice a sudden lowering of the brake fluid level, inspect brake pads for wear and brake system for leaks.

NOTICE

When installing new brake pads, fill the reservoir to the MAX mark. This reservoir can be used as a wear indicator, as the pads wear out, the level will decrease. When it is close to or at the MIN mark, inspect brake pads and replace if necessary. While this can be used as an indicator, the BEST way to inspect brake wear is to inspect the pads themselves.

PRE-RIDE INSPECTIONS

FRONT BRAKE FLUID INSPECTION

1. Turn handlebars or adjust the motorcycle until top of reservoir is level.



2. View front brake fluid level through the fluid reservoir. The fluid should be clear and between the MIN ① and MAX ② markings.
3. Wipe area around reservoir cover with a clean cloth.
4. Wipe brake fluid container with a clean cloth.

5. Remove screws ③, reservoir cover ④.

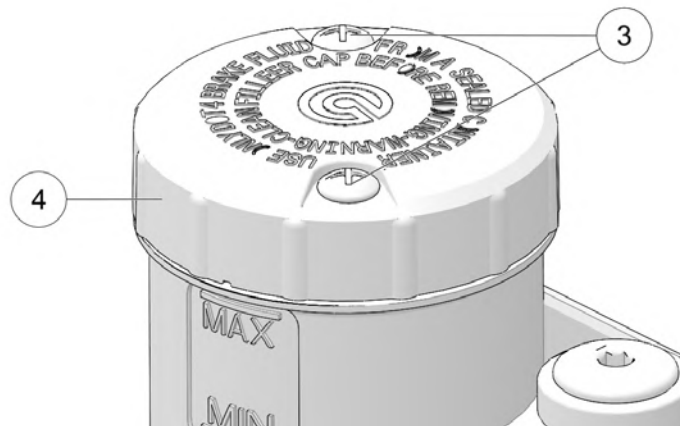

6. Carefully add enough DOT 4 brake fluid to bring level to between the MIN ① and MAX ② markings. Always add brake fluid from a new, unopened container.
7. Reinstall reservoir cover and torque screws to specification.

TORQUE

Front Master Cylinder Cap Screws:
13 in-lbs (1.4 N·m)

REAR BRAKE FLUID INSPECTION

1. Fluid level is checked at the rear brake master cylinder reservoir.
2. Ensure vehicle is upright, then view fluid level through the fluid reservoir. The fluid should be clear and between the MIN ⑤ and MAX ⑥ markings.



3. Wipe area around reservoir cover with a clean cloth.
4. Wipe brake fluid container with a clean cloth.

5. Remove reservoir cover ⑦.



6. Carefully add enough DOT 4 brake fluid to bring level to between the MIN ⑤ and MAX ⑥ markings. Always add brake fluid from a new, unopened container.
7. Install diaphragm and cover.

PRE-RIDE INSPECTIONS

FRONT BRAKE LEVER

1. Pull the front brake lever toward the handlebar and hold it. The lever should move freely and smoothly. The lever should feel firm and continue to feel firm until released.
2. Release the lever. It should return to its rest position quickly when released.
3. If the front brake lever fails to perform as stated, service the brake lever before riding.

REAR BRAKE PEDAL

1. Press downward on the rear brake pedal. It should move freely and smoothly. The pedal should feel firm and continue to feel firm until released.
2. Release the pedal. It should return to its rest position quickly when released.
3. If the rear brake pedal fails to perform as stated or travels too far before beginning to engage the brake, service the brakes before riding.

BRAKE LINES

Inspect all brake hoses and connections for dampness or stains from leaking or dried fluid. Tighten any leaking connections to the proper torque values and replace components as necessary. See the *INDIAN MOTORCYCLE Service Manual* or an authorized INDIAN MOTORCYCLE dealer or other qualified dealer.



Brake fluid leaks or low brake fluid levels could cause brake system failure, which could result in serious injury or death. Do not operate the vehicle with low brake fluid levels or when leaks are evident (dampness or stains from dried fluid). See your authorized INDIAN MOTORCYCLE dealer or other qualified dealer.

MECHANICAL CLUTCH

1. Squeeze the clutch lever ① toward the handlebar and release it. It should move freely and smoothly, and it should return to the rest position quickly when released. If the lever fails to perform as stated, service the clutch lever before riding.

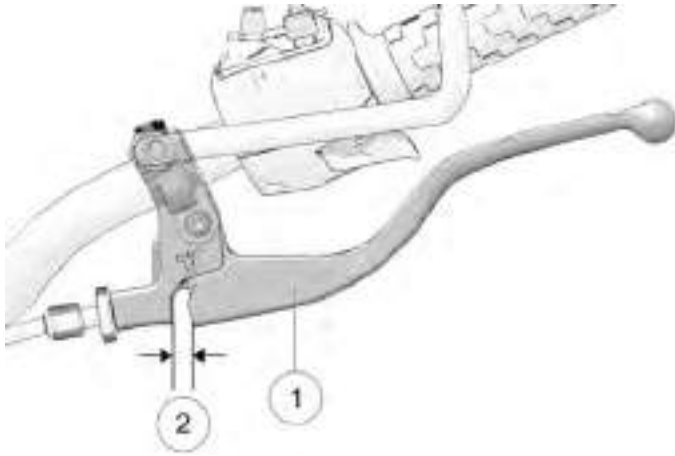

2. Clutch lever freeplay ② (gap) is the amount of lever movement from the rest position to the point of cable resistance. Measure the gap between the clutch lever and the lever housing. Adjust clutch lever freeplay if necessary.

MEASUREMENT

Clutch Lever Freeplay:
0.020-0.060 in (0.5-1.5 mm)

NOTICE

The starter interlock switch is dependent on the clutch lever freeplay being set correctly to ensure activation of the clutch safety switch.

THROTTLE

Rotate the throttle control grip. It should rotate smoothly from the rest position to the completely open position. It should return to the rest position quickly when released.

FRONT SUSPENSION

Inspect the front forks for oil leaks or damage, and verify smooth suspension operation. See the Front Fork / Suspension Inspection section for details.

REAR SUSPENSION

Check the rear shock absorber mounting and inspect for leaks. See your dealer for service if you discover leaks or malfunction of any kind. See the Rear Shock Preload sections starting on page 109 regarding inspection and adjustments for details.

PRE-RIDE INSPECTIONS

WARNING

Inadequate ground clearance could result in components contacting the ground, causing loss of control, and serious injury or death. Always ensure ground clearance is at specification.

SPROCKET INSPECTION

NOTICE

Drive chain and sprocket service life are maximized and drive line noise minimized by proper cleaning. Cleaning interval is approximately every tire change, or more often if operated in dirty, dusty, or high debris environments.

Clean the chain using a chain brush or clean rag to remove any dirt or grit. The chain must be lubricated using Indian Motorcycle chain lube (2884172).

CAUTION

Always have the motorcycle off and the transmission in neutral when performing this procedure.

CAUTION

Do not use a de-greaser to clean the chain. De-greaser may damage the chain o-rings and cause premature wear.

1. Inspect front and rear sprocket teeth for wear or damage from foreign material.

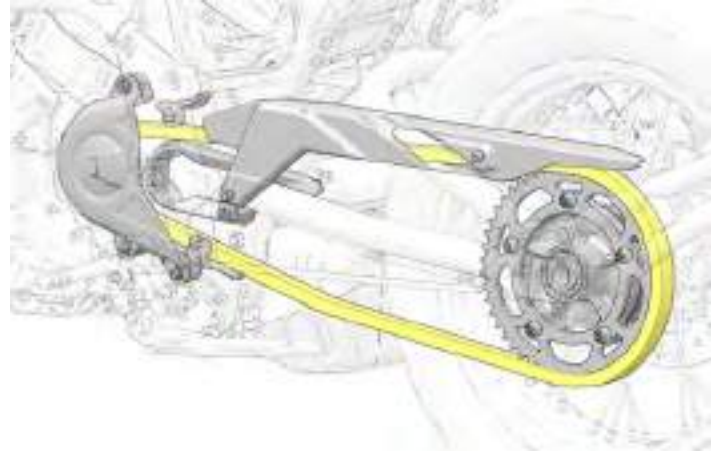

2. Closely inspect drive chain condition.

Things to look for:

- wear pattern - ensure even wear throughout sprocket
- cracks
- missing teeth
- uniform teeth size

DRIVE CHAIN

1. Inspect drive chain for excessive wear or sag, foreign substance (grit), or any other damage.
2. If any damage is found, chain should be replaced.
3. If the drive chain or sprocket is being replaced due to damage, replace chain and both sprockets as a set if drive system has more than 5,000 miles (8,000 km) of use.

FUEL LEVEL

1. Position the motorcycle on level ground on its side stand.
2. Slowly open the fuel cap.
3. View the fuel level in the tank.
4. Refuel as needed to the bottom of the filler neck. See the Fueling section for fueling instructions. See the Fuel Recommendations section for fuel specifications.

SIDE-STAND

1. On level ground, straddle the motorcycle and bring it to the fully upright position.
2. Move the side-stand up to the stored position and down to the fully extended position several times. It should move smoothly and quietly. Make sure the return spring holds the side-stand tightly in place when the side-stand is in the stored position. Adjust or replace a loose spring.

3. Inspect the side-stand pivot bolt for looseness or wear. Tighten or replace a loose or worn bolt.
4. Periodically test the side-stand safety switch for proper operation. With the transmission in gear and brakes applied, attempt to start the engine while the side-stand is down. The engine should NEVER start in any gear except neutral if the side-stand is down. If the engine starts during this test, see your dealer for service.

FASTENERS

1. Inspect the entire motorcycle chassis and engine for loose, damaged or missing fasteners.
2. Tighten loose fasteners to the proper torque. See the *INDIAN MOTORCYCLE Service Manual* or an authorized INDIAN MOTORCYCLE dealer or other qualified dealer.

NOTICE

Always replace stripped, damaged or broken fasteners before riding. Use genuine INDIAN MOTORCYCLE fasteners of equal size and strength.

OPERATION OVERVIEW

The operation section of this manual describes how to ensure maximum performance and longevity through the proper care and operation of your motorcycle.

Important areas covered by the operation section include:

- Engine Break-In
- Fueling
- Starting the Engine
- Shifting Gears
- Accelerating
- Braking
- Stopping the Engine
- Parking

NOTICE

Even if you're an experienced motorcycle operator or passenger, read all of the safety information in this manual before operating the motorcycle.

NOTICE

Failure to properly follow the engine break-in procedures outlined in this manual can result in serious damage to the engine. Follow all break-in procedures carefully. Avoid full throttle operation and other conditions that may place an excessive load on the engine during the break-in period.

ENGINE BREAK-IN

The engine break-in period for your motorcycle is the first 500 miles (800 km) of operation. During this break-in period, critical engine parts require special wear-in procedures so they seat and mate properly. Read, understand and follow all break-in procedures to ensure the long-term performance and durability of your engine.

The more cautiously you treat your motorcycle during the break-in period, the more satisfied you will be with its performance later on. Overloading the engine at low RPM and/or running the engine prematurely at high RPM may result in damage to the engine components.

Observe the following precautions during the break-in period:

- Upon initial start-up, do not allow the engine to idle for long periods as overheating can occur.
- Avoid fast starts with wide open throttle. Drive slowly until the engine warms up.
- Avoid running the engine at extremely low RPM in higher gears (lugging the engine).
- Drive within the recommended operating speeds and gears. See page 66 and page 70.

OPERATION

NOTICE

Engine calibration can take up to 10 minutes of idle with the coolant temperature above 181 °F (83 °C) without cylinder deactivation enabled to fully adapt when vehicle is new or after a calibration flash.

OPERATING SPEEDS AND GEARS

| ODOMETER | BREAK-IN PROCEDURE |
|----------------------------|---|
| 0-90 miles (0-145 km) | Do not operate for extended periods above 1/3 throttle or at any one throttle position. Vary engine speed frequently. |
| 91-300 miles (146-483 km) | Do not operate for extended periods above 1/2 throttle or at any one throttle position. Vary engine speed frequently. |
| 301-500 miles (484-800 km) | Do not operate for extended periods above 3/4 throttle. |
| At 500 miles (At 800 km) | Perform the break-in maintenance outlined in the maintenance section of this manual. Break-in maintenance should be performed by a dealership. Break-in maintenance must include inspection, adjustments, fastener tightening and an engine oil and filter change. Performing break-in maintenance at the required odometer reading helps ensure peak engine performance, minimal exhaust emissions and maximum service life of the engine. |

FUELING

Always dismount the motorcycle and refuel on level ground with the sidestand down. Review the fuel warnings. See page 17. Use only the recommended fuel. See page 158.

WARNING

Overflows or spilled gasoline could contact a hot engine or exhaust system and cause a fire, which could result in serious injury or death. Do not allow gasoline to contact hot components.

WARNING

Always open the fuel cap slowly and fill the fuel tank slowly to prevent spillage. Do not overfill the fuel tank. Leave space in the tank to allow for the fuel to expand.



1. To open the fuel tank cap ①, insert the ignition key into the cap lock and turn it counter-clockwise.
2. Insert the fuel nozzle into the fuel tank filler neck.
3. Hold the nozzle while filling. Do not rest the weight of the nozzle and hose on the filler neck. Do not leave the nozzle unattended.
4. Add fuel to the tank until it crests the oval-shaped opening in the filler neck. The tank is full at this level. Do not overfill the fuel tank. Fuel level should not rise into fill neck funnel. Overfilling may result in degraded performance of engine and evaporative emissions control system.

5. Always close and lock the fuel cap before remounting the motorcycle. With the key rotated counter-clockwise, close the fuel cap with your opposite hand and press it down firmly. Turn the key clockwise to secure the lock.
6. If the motorcycle runs out of fuel, prime the system before attempting to restart the engine. See page 67.

NOTICE

Fuel can damage painted surfaces and plastic parts. If gasoline spills on the any part of the motorcycle, immediately rinse it off with water or wipe it dry with a clean cloth.

PRIMING THE FUEL SYSTEM

If the motorcycle runs out of fuel, prime the fuel system before attempting to restart the engine.

1. Fill the fuel tank.
2. Turn the ignition key to the ON position.
3. Move the engine stop/run switch to the RUN position.
4. Allow the fuel pump to run until it stops (about 2 seconds).
5. Move the engine stop/run switch to the STOP position and wait 15 seconds.
6. Repeat steps 3–5 four to five times.
7. Turn the key to the OFF position.
8. Start the engine. See page 68.

OPERATION

STARTING THE ENGINE

The starter interlock system allows the engine to be started only when the transmission is in neutral, or when the transmission is in gear with the clutch disengaged (clutch lever pulled in).

1. Perform the Pre-Ride Inspections. See page 53. Properly secure any cargo.
2. Straddle the motorcycle and bring it to the fully upright position. Retract the sidestand.
3. Turn the ignition key to the ON position.
4. Move the engine stop/run switch to the RUN position.
5. Shift the transmission to neutral.
6. Apply the front brakes. Disengage the clutch (pull the clutch lever fully toward the handlebar).
7. Press and release the starter switch to start the engine. The starter motor will crank until the engine starts, but no more than 3 seconds. If the engine does not start, wait five seconds, then try again.
8. *If starting a COOL engine*, DO NOT open the throttle while starting. Idle speed is computer controlled and will adjust automatically. Allow the engine to warm up for 30 seconds minimum at low RPM after starting. Do not run the engine above 2500 RPM. *If starting a WARM engine*, DO NOT open the throttle while starting.

9. If either the check engine indicator or the low oil pressure indicator remains on after the engine starts, stop the engine *immediately*. Refer to the low oil pressure indicator information on page 33.

NOTICE

Operating an engine with a misfire or non-firing cylinder can overheat the catalytic converter, which could result in catalytic converter damage and loss of emission control. **DO NOT OPERATE** the motorcycle if a misfire or non-firing cylinder exists.

10. Leave the throttle closed and allow the engine to idle. Idle speed will gradually slow to normal as the engine warms to operating temperature.

TIP

Do not rev the engine or put the transmission in gear immediately after starting the engine. Allow the engine to idle for about 30 seconds after a warm start or at least one minute after a cold start (longer in cold weather). This will allow oil to reach all areas before the engine is put under load.

NOTICE

Do not run the engine at high RPM with the clutch disengaged or the transmission in neutral. Maximum safe engine speed is 8300 RPM. Never exceed the maximum safe RPM as this could result in serious engine damage.

IDLE SHUT DOWN

If the motorcycle is left idling under normal conditions without user input for 15 minutes, the engine will shut down. If a misfire has been detected, the engine will shut down after 5 minutes without operator input. At any time during the idle countdown timer period, user input to the clutch/brake levers, or throttle, will end the shutdown sequence. At 3 minutes prior to engine shutdown, a notification will be provided to the user.

SHIFTING GEARS

WARNING

Forced shifting (with clutch engaged) could cause damage to the engine, transmission and drive train. Such damage could cause loss of control, which could result in serious injury or death. Always pull the clutch lever fully toward the handlebars to disengage the clutch before shifting gears.

Your motorcycle is equipped with a six-speed transmission. Neutral is located between first and second gear.

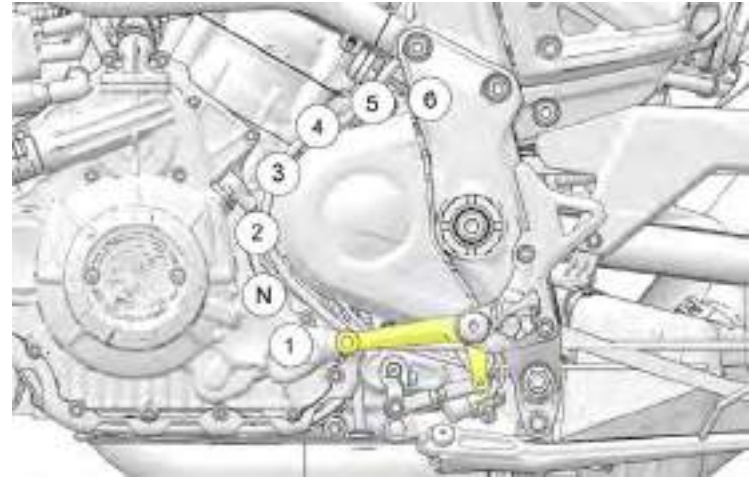

Press downward on the toe lever to shift to a lower gear. Lift upward on the toe lever to shift to a higher gear. Release the clutch lever after each gear shift.

Shifting to neutral is easiest if the motorcycle is rolling slowly. To shift from first gear to neutral, gently lift the toe lever a half stroke.

TIP

The transmission is in neutral if you can move the motorcycle forward or rearward freely without disengaging the clutch. If the ignition switch is in the ON position, the neutral indicator illuminates when the transmission is in neutral.

OPERATION

SHIFTING GEARS WHILE STATIONARY

To locate neutral when the motorcycle is stationary, use one of the following techniques to load and unload the transmission:

1. With the clutch disengaged (lever pulled inward), shift into neutral while rocking the motorcycle forward and rearward.
2. With the transmission in first gear, gently release the clutch until it just begins to engage. Apply upward pressure on the toe lever and quickly pull the clutch inward.

NOTICE

There is a Neutral indicator light on the instrument cluster.

SHIFTING GEARS WHILE DRIVING

WARNING

Downshifting improperly could cause transmission damage, loss of traction and loss of control, which could result in serious injury or death.

- Reduce speed before downshifting. Always downshift within the recommended shift points.
- Use extreme caution when downshifting on wet, slippery or other low traction surfaces. Release the clutch lever very gradually in these conditions.
- Avoid downshifting in a curve. Downshift before entering the curve.

1. Start the engine. See page 68.
2. With the engine at idle speed, apply the front brakes.
3. Disengage the clutch (pull the clutch lever fully toward the handlebar).
4. Push the toe lever downward until you feel it stop in first gear.
5. Release the brake lever.
6. Simultaneously release the clutch lever while opening the throttle (rolling the throttle control grip rearward) in one smooth motion. As the clutch begins to engage, the motorcycle will move forward.
7. To shift to a higher gear, accelerate smoothly to the recommended shift point. See *Recommended Shift Points* chart. With a quick motion, simultaneously close the throttle completely and disengage the clutch. Raise the toe shift lever until you feel it stop at the next gear. Simultaneously release the clutch lever and open the throttle in one smooth motion.
8. To shift to a lower gear (downshift), simultaneously pull the clutch lever toward the handlebar and close the throttle. Move the toe shift lever downward until you feel it stop at the next gear. Simultaneously release the clutch lever while opening the throttle.

TIP

Within the recommended speed ranges (see Recommended Shift Points chart), you can downshift to slow the motorcycle or to increase power. You may want to downshift when climbing a hill or passing. Downshifting also helps to decrease speed when combined with closing the throttle.

RECOMMENDED SHIFT POINTS***FTR RALLY***

| UPSHIFTING (ACCELERATING) | | DOWNSHIFTING (DECELERATING) | |
|---------------------------|-------------------|-----------------------------|-------------------|
| GEAR CHANGE | RECOMMENDED SPEED | GEAR CHANGE | RECOMMENDED SPEED |
| 1 to 2 | 16 mph (26 km/h) | 6 to 5 | 42 mph (67 km/h) |
| 2 to 3 | 28 mph (45 km/h) | 5 to 4 | 35 mph (57 km/h) |
| 3 to 4 | 35 mph (57 km/h) | 4 to 3 | 29 mph (46 km/h) |
| 4 to 5 | 42 mph (67 km/h) | 3 to 2 | 16 mph (26 km/h) |
| 5 to 6 | 47 mph (76 km/h) | 2 to 1 | 11 mph (18 km/h) |

FTR / FTR S / FTR R CARBON

| UPSHIFTING (ACCELERATING) | | DOWNSHIFTING (DECELERATING) | |
|---------------------------|-------------------|-----------------------------|-------------------|
| GEAR CHANGE | RECOMMENDED SPEED | GEAR CHANGE | RECOMMENDED SPEED |
| 1 to 2 | 17 mph (27 km/h) | 6 to 5 | 45 mph (72 km/h) |
| 2 to 3 | 30 mph (49 km/h) | 5 to 4 | 38 mph (61 km/h) |
| 3 to 4 | 38 mph (61 km/h) | 4 to 3 | 30 mph (49 km/h) |
| 4 to 5 | 45 mph (72 km/h) | 3 to 2 | 17 mph (27 km/h) |
| 5 to 6 | 51 mph (82 km/h) | 2 to 1 | 12 mph (20 km/h) |

OPERATION

BRAKING

Always allow sufficient stopping distance so that brakes can be applied gradually.

TIP

Applying slightly more front brake than rear brake generally provides the best braking performance.

1. To slow the motorcycle with the brakes, close the throttle and apply the front and rear brakes gradually.

TIP

When the anti-lock brakes engage during a braking event, the rider will feel pulsing at the brake lever. Continue to apply steady pressure to the brakes for the best stopping performance.

2. As the motorcycle slows, disengage the clutch, or downshift each time vehicle speed reaches a downshift point.

WARNING

Braking improperly could result in loss of control, which could result in serious injury or death. Avoid braking abruptly. Always apply the brakes gradually, especially on wet, slippery or other low traction surfaces. Avoid braking in a curve or turn. Bring the motorcycle to the upright position before applying the brakes.

ACCELERATING

Accelerate by opening the throttle (rolling the throttle control grip rearward). For even acceleration, open the throttle with a smooth, continuous motion. When you reach the recommended speed for upshifting, shift up one gear.

WARNING

Accelerating abruptly could cause your body to shift rearward suddenly, which could result in loss of control. Accelerating abruptly could also cause loss of control on low traction surfaces. Loss of control could result in serious injury or death. Always accelerate gradually, especially on wet, slippery or other low traction surfaces.

STOPPING THE ENGINE

Before stopping the engine, bring the motorcycle to a complete stop. Shift to neutral or disengage the clutch.

WARNING

Stopping the engine with the transmission in gear while the motorcycle is moving could cause loss of rear wheel traction or engine and transmission damage, which could cause loss of control and serious injury or death. Always stop the engine after the motorcycle is fully stopped and the transmission is in neutral. If the engine stops unexpectedly while the motorcycle is moving, pull the clutch and guide the motorcycle to a safe location off the road and away from traffic. Turn the ignition switch off.

1. When fully stopped, shift into neutral.
2. Move the engine stop/run switch to the STOP position.
3. Turn the ignition switch off. Remove the ignition key.

USING CRUISE CONTROL

The cruise control switches are located on the left hand control. Read this section and understand how to safely operate this feature before using the cruise control.

Cruise control can be activated and adjusted from the left-hand control using the Cruise Control Switch. See page 28.

WARNING

Improper operation of cruise control could cause loss of control and result in serious injury or death. Follow all cruise operation procedures carefully. Never use cruise control when roads are wet or slippery. Do not use cruise control when riding in heavy or congested traffic.

CRUISE CONTROL TIPS

- Cruise control can be set in gears 2-6.
- Vehicle speed must be above 20 mph (32 km/h).
- Set speed will vary slightly in hilly terrain.
- Cruise control will not resume a pre-set speed if the resulting acceleration or deceleration rate is too high or too low. For example, resuming a set speed of 70 mph (113 km/h) from 40 mph (64 km/h), while in 6th gear, may cause cruise to disengage.
- Cruise control will not engage if brake lights are not operating properly.
- The clutch or either brake must have been activated at least once since the engine was started for the cruise control to function.

SET SPEED

1. Press and release the center of the cruise control switch ①. The cruise control indicator will illuminate in the instrument cluster. Cruise control is enabled, but not set.
2. Accelerate to the desired speed and press down on the cruise control switch to activate cruise control. The Cruise Control Set indicator lamp will illuminate. Cruise control is set to the desired speed.

RESUME SPEED

After disengaging the cruise control with the brake, throttle or clutch, press up on the cruise control switch to return to the set speed.

OPERATION

ACCELERATE

While cruise control is engaged, tap up on the cruise control switch to increase speed in approximately 1 mph (1-2 km/h) increments. Press and hold up on the cruise control switch to accelerate to a new set speed (resets when switch is released).

TIP

If you use the throttle to accelerate and then release it, the cruise control will resume the previously set speed.

DECELERATE

While cruise control is engaged, tap and release down on the cruise control switch to decrease speed in approximately 1 mph (1-2 km/h) increments. Press and hold the down on the cruise control switch to decelerate to a new set speed (resets when switch is released), or to the minimum cruise speed of 20 mph (32 km/h).

CANCEL CRUISE CONTROL

To temporarily cancel the cruise control and allow use of the resume feature:

- Apply the brakes, or
- Pull the clutch lever in, or
- Roll the throttle grip forward past the idle position

To cancel the cruise control and erase the set speed from memory, press the cruise on/off switch.

PARKING

Choose a firm level surface to park the motorcycle.

1. When fully stopped, shift into neutral.
2. Stop the engine.
3. Fully extend the sidestand.
4. Turn the handlebars to the left and lean the motorcycle to the left until the sidestand firmly supports the motorcycle.
5. Remove the ignition key.

PARKING ON A SLOPE

If parking on a slope is unavoidable, park with the front wheel uphill from the rear wheel. Place the transmission in first gear and position the motorcycle so that it is stable when it rests on the sidestand.

NOTICE

Always park with the front wheel uphill from the rear wheel when parking on a slope. If the front wheel is downhill from the rear wheel, the sidestand could retract and cause a tipover.

PARKING ON A SOFT SURFACE

If parking on a soft surface is unavoidable, place a sidestand footrest under the foot of the sidestand to provide a firm surface. The sidestand footrest must be strong enough and large enough to support the motorcycle's weight without sinking into the parking surface.

Asphalt becomes soft in hot weather. A sidestand can sink into soft asphalt and the motorcycle may fall. When parking on asphalt in hot weather, use a sidestand footrest.



CAUTION

Hot engine and exhaust components can cause burns to skin and can ignite a fire if exposed to flammable materials. Always park the motorcycle clear of flammable materials and where people are not likely to contact hot components.

MAINTENANCE

SAFETY DURING SERVICE PROCEDURES



Failure to follow all recommended precautions and procedures could result in serious injury or death. Always heed all safety precautions and follow all operation, inspection and maintenance procedures outlined in this manual.

- Improperly installed or adjusted components can make the motorcycle unstable or hard to handle. Improperly installed electrical components can cause engine or electrical system failure. In either event, damage or serious injury could result. If you do not have the time, tools and expertise necessary to complete a procedure properly, please see your dealer for service.
- Review the safety-related maintenance information in the Safety Maintenance section.
- Before beginning any maintenance procedure, read the instructions for the entire procedure.
- Always position the motorcycle on a firm level surface before performing service. Make sure the motorcycle will not tip or fall while elevated or while on the sidestand. See the Elevating the Vehicle section for details.
- Hot engine and exhaust components can cause burns to skin and can ignite a fire if exposed to flammable materials. Always park the motorcycle clear of flammable materials and where people are not likely to contact hot components.
- Wear eye and face protection when using pressurized air.
- Never start the engine or let it run in an enclosed area. Engine exhaust fumes are poisonous and can cause loss of consciousness or death in a short time.
- During some procedures you may use potentially hazardous products such as oil or brake fluid. Always follow the instructions and warnings on the product packaging.

MAINTENANCE

PROPER MAINTENANCE

Proper maintenance assures the highest level of safety, durability and dependability for your motorcycle. Break-in maintenance is required to ensure warranty coverage and proper emissions system operation.

- Perform the *break-in maintenance procedures* when the motorcycle's odometer registers 500 miles (800 km). Please see your authorized dealer for this service.
- Perform the recommended *periodic maintenance* at the intervals specified in the Periodic Maintenance Table beginning on page 79.

ROAD TESTS

Before returning the motorcycle to regular use after performing service, road test it in a safe environment. Pay special attention to the proper fit and operation of all serviced components. Make any corrections or additional adjustments necessary to ensure safe vehicle performance.

BREAK-IN MAINTENANCE

Perform the break-in maintenance procedures when the motorcycle's odometer registers 500 miles (800 km). Please see your authorized dealer for this service.

Performing the break-in maintenance will help ensure optimum engine performance for the entire service life of the engine. Your dealer will change engine oil, inspect all fluids and serviceable components, ensure that all fasteners are tightened and make other adjustments as needed.

MAJOR MAINTENANCE

Major repairs typically require technical skills and specially designed tools. Emission system service requires special tools and training and should be performed by your dealer. See the *INDIAN MOTORCYCLE Service Manual* or an authorized INDIAN MOTORCYCLE dealer or other qualified dealer.

PERIODIC MAINTENANCE

Inspect, clean, lubricate, adjust and replace parts as necessary. When inspection reveals the need for replacement parts, use genuine INDIAN MOTORCYCLE parts available from your dealer. Record service and maintenance information in the Maintenance Log beginning on page 171.

Perform maintenance at the intervals specified in the Periodic Maintenance Interval Chart. *Vehicles subjected to severe use must be inspected and serviced more frequently.*

SEVERE USE DEFINITION

- high speed operation for extended periods
- low speed operation for extended periods
- operation in dusty or otherwise adverse conditions
- operation in cold weather (temperatures below freezing)

MAINTENANCE INTERVALS

The maintenance interval charts outline required maintenance and inspection based on vehicle miles. Each table states the number of miles that service is required on the vehicle. Some items or components may need to be serviced more often due to severe use. When the vehicle goes beyond 50,000 miles (80,000 km), return to the 500 miles (800 km) chart and start the interval process over.

XU - Perform these procedures more often for vehicles subjected to severe use.

D - Have an authorized INDIAN MOTORCYCLE dealer perform these services.

E - Emission Control System Service (California / International)

500 MILES (800 KM) SERVICE

| ITEM | | REMARKS |
|--------|-------------------------------------|--|
| D | Crankcase Ventilation System | Inspect; tighten, clean, adjust |
| D | Drive Chain | Inspect; clean, lubricate |
| D | Engine Mount Fasteners | Inspect; tighten, adjust |
| XU | Engine Oil & Filter Change | Change oil and filter, inspect used oil for contaminants |
| E | Evaporative Emission Control System | Inspect; clean |
| E | Exhaust System | Inspect; tighten, adjust |
| D | Fuel System | Inspect; clean |
| D | Oil Lines / Oil System Inspection | Inspect; clean, adjust if necessary |
| | Battery | Check terminals; clean; test |
| D | Brake Fluid | Change every two years (DOT 4) |
| XU / D | Brake Pads | Inspect pad wear; replace if worn beyond service limit |
| D | Clutch Lever | Lubricate with proper lubricant as directed |
| D | Clutch Cable Freeplay | Inspect; adjust if necessary |

MAINTENANCE

| ITEM | | REMARKS |
|------|----------------------------|--|
| D | Control Cable Ends | Inspect; lubricate with proper lubricant as directed |
| D | Fasteners | Inspect; tighten if necessary |
| D | Front Brake Lever | Adjust if necessary, lubricate with proper lubricant as directed |
| D | Front Fork Oil | Inspect |
| D | Front Forks and Front Axle | Inspect; adjust if necessary |
| D | Head Light | Inspect; adjust if necessary |
| D | Gear Shift Pedal | Inspect; lubricate, adjust if necessary |
| D | Rear Brake Pedal | Inspect; lubricate, adjust if necessary |
| D | Driver and Passenger Pegs | Inspect; lubricate if necessary |
| D | Rear Shock Absorber | Inspect; adjust if necessary |
| D | Rear Wheel Alignment | Inspect; adjust if necessary |
| | Road Test | Perform Road Test |
| D | Sidestand | Lubricate with proper lubricant as directed |
| D | Steering Bearings | Inspect |
| D | Suspension Linkage, Rear | Inspect |
| D | Swing Arm and Rear Axle | Inspect |
| D | Tires / Wheels | Inspect tread depth, sidewall cracking, wear patterns |

2,500 MILES (4,000 KM) SERVICE

| ITEM | | REMARKS |
|------|------------------------------|---------------------------------|
| XU | Air Filter | Inspect; clean |
| D | Crankcase Ventilation System | Inspect; tighten, clean, adjust |

| ITEM | | REMARKS |
|--------|-------------------------------------|---|
| D | Drive Chain | Inspect; clean, lubricate |
| E | Evaporative Emission Control System | Inspect; clean |
| E | Exhaust System | Inspect; tighten, adjust |
| D | Fuel System | Inspect; clean |
| D | Oil Lines / Oil System Inspection | Inspect; clean, adjust if necessary |
| | Battery | Check terminals; clean; test |
| D | Brake Fluid | Change every two years (DOT 4) |
| XU / D | Brake Pads | Inspect pad wear; replace if worn beyond service limit |
| D | Clutch Cable Freeplay | Inspect; adjust if necessary |
| D | Fasteners | Inspect; tighten if necessary |
| D | Front Brake Lever | Inspect; adjust if necessary, lubricate with proper lubricant as directed |
| D | Front Forks and Front Axle | Inspect; adjust if necessary |
| D | Head Light | Inspect; adjust if necessary |
| D | Gear Shift Pedal | Inspect; lubricate, adjust if necessary |
| D | Rear Brake Pedal | Inspect; lubricate, adjust if necessary |
| D | Driver and Passenger Pegs | Inspect; lubricate if necessary |
| D | Rear Shock Absorber | Inspect; adjust if necessary |
| D | Rear Wheel Alignment | Inspect; adjust if necessary |
| | Road Test | Perform Road Test |
| D | Sidestand | Inspect; adjust if necessary, lubricate with proper lubricant as directed |
| D | Steering Bearings | Inspect |

MAINTENANCE

| ITEM | | REMARKS |
|------|--------------------------|---|
| D | Suspension Linkage, Rear | Inspect |
| D | Swing Arm and Rear Axle | Inspect |
| D | Tires / Wheels | Inspect tread depth, sidewall cracking, wear patterns |

5,000 MILES (8,000 KM) SERVICE

| ITEM | | REMARKS |
|--------|-------------------------------------|--|
| XU | Air Filter | Inspect; clean |
| D | Crankcase Ventilation System | Inspect; tighten, clean, adjust |
| D | Drive Chain | Inspect; clean, lubricate |
| D | Chain Sliders | Inspect; replace as needed |
| E | Evaporative Emission Control System | Inspect; clean |
| E | Exhaust System | Inspect; tighten, adjust |
| D | Fuel System | Inspect; clean |
| D | Oil Lines / Oil System Inspection | Inspect; clean, adjust if necessary |
| | Battery | Check terminals; clean; test |
| D | Brake Fluid | Change every two years (DOT 4) |
| XU / D | Brake Pads | Inspect pad wear; replace if worn beyond service limit |
| D | Clutch Lever | Inspect; adjust if necessary |
| D | Clutch Cable Freeplay | Inspect; adjust if necessary |
| D | Control Cable Ends | Inspect; lubricate with proper lubricant as directed |
| D | Fasteners | Inspect; tighten if necessary |

| ITEM | | REMARKS |
|------|----------------------------|---|
| D | Front Brake Lever | Adjust if necessary, lubricate with proper lubricant as directed |
| D | Front Fork Oil | Replace at specified interval or every 2 years |
| D | Front Forks and Front Axle | Inspect; adjust if necessary |
| D | Gear Shift Pedal | Inspect; lubricate, adjust if necessary |
| D | Rear Brake Pedal | Inspect; lubricate, adjust if necessary |
| D | Driver and Passenger Pegs | Inspect; lubricate if necessary |
| D | Rear Shock Absorber | Inspect; adjust if necessary |
| D | Rear Wheel Alignment | Inspect; adjust if necessary |
| | Road Test | Perform Road Test |
| D | Sidestand | Inspect; adjust if necessary, lubricate with proper lubricant as directed |
| D | Steering Bearings | Inspect |
| D | Suspension Linkage, Rear | Inspect |
| D | Swing Arm and Rear Axle | Inspect |
| D | Tires / Wheels | Inspect tread depth, sidewall cracking, wear patterns |

10,000 MILES (16,000 KM) SERVICE

| ITEM | | REMARKS |
|------|------------------------------|---------------------------------|
| XU | Air Filter | Inspect; clean |
| D | Crankcase Ventilation System | Inspect; tighten, clean, adjust |
| D | Drive Chain | Inspect; clean, lubricate |
| D | Chain Sliders | Inspect; replace as needed |
| D | Engine Compression | Inspect; correct if necessary |

MAINTENANCE

| ITEM | | REMARKS |
|--------|-------------------------------------|--|
| XU | Engine Oil & Filter Change | Change oil and filter, inspect used oil for contaminants |
| E | Evaporative Emission Control System | Inspect; clean |
| E | Exhaust System | Inspect; tighten, adjust |
| D | Fuel System | Inspect; clean |
| D | Oil Lines / Oil System Inspection | Inspect; clean, adjust if necessary |
| D / E | Spark Plugs | Inspect; replace as needed; torque to specification |
| | Battery | Check terminals; clean; test |
| D | Brake Fluid | Replace (DOT 4) |
| XU / D | Brake Pads | Inspect pad wear; replace if worn beyond service limit |
| D | Clutch Lever | Lubricate with proper lubricant as directed |
| D | Clutch Cable Freeplay | Inspect; adjust if necessary |
| D | Control Cable Ends | Lubricate with proper lubricant as directed |
| D | Fasteners | Inspect; tighten if necessary |
| D | Front Brake Lever | Adjust if necessary, lubricate with proper lubricant as directed |
| D | Front Fork Oil | Replace at specified interval or every 2 years |
| D | Front Forks and Front Axle | Inspect; adjust if necessary |
| D | Head Light | Inspect; adjust if necessary |
| D | Gear Shift Pedal | Inspect; lubricate, adjust if necessary |
| D | Rear Brake Pedal | Inspect; lubricate, adjust if necessary |
| D | Driver and Passenger Pegs | Inspect; lubricate if necessary |
| D | Rear Shock Absorber | Inspect; adjust if necessary |

| ITEM | | REMARKS |
|------|--------------------------|---|
| D | Rear Wheel Alignment | Inspect; adjust if necessary |
| | Road Test | Perform Road Test |
| D | Sidestand | Lubricate with proper lubricant as directed |
| D | Steering Bearings | Inspect |
| D | Suspension Linkage, Rear | Inspect |
| D | Swing Arm and Rear Axle | Inspect |
| D | Tires / Wheels | Inspect tread depth, sidewall cracking, wear patterns |

15,000 MILES (24,000 KM) SERVICE

| ITEM | | REMARKS |
|--------|-------------------------------------|--|
| XU | Air Filter | Replace |
| D | Crankcase Ventilation System | Inspect; tighten, clean, adjust |
| D | Drive Chain | Replace |
| D | Chain Sliders | Inspect; replace as needed |
| E | Evaporative Emission Control System | Inspect; clean |
| E | Exhaust System | Inspect; tighten, adjust |
| D | Fuel System | Inspect; clean |
| D | Oil Lines / Oil System Inspection | Inspect; clean, adjust if necessary |
| | Battery | Check terminals; clean; test |
| D | Brake Fluid | Change every two years (DOT 4) |
| XU / D | Brake Pads | Inspect pad wear; replace if worn beyond service limit |
| D | Clutch Lever | Inspect; adjust if necessary |

MAINTENANCE

| ITEM | | REMARKS |
|------|----------------------------|---|
| D | Clutch Cable Freeplay | Inspect; adjust if necessary |
| D | Control Cable Ends | Inspect; adjust if necessary |
| D | Fasteners | Inspect; tighten if necessary |
| D | Front Brake Lever | Adjust if necessary, lubricate with proper lubricant as directed |
| D | Front Fork Oil | Replace |
| D | Front Forks and Front Axle | Inspect; adjust if necessary |
| D | Gear Shift Pedal | Inspect; lubricate, adjust if necessary |
| D | Rear Brake Pedal | Inspect; lubricate, adjust if necessary |
| D | Driver and Passenger Pegs | Inspect; lubricate if necessary |
| D | Rear Shock Absorber | Inspect; adjust if necessary |
| D | Rear Wheel Alignment | Inspect; adjust if necessary |
| | Road Test | Perform Road Test |
| D | Sidestand | Inspect; adjust if necessary, lubricate with proper lubricant as directed |
| D | Steering Bearings | Inspect |
| D | Suspension Linkage, Rear | Inspect |
| D | Swing Arm and Rear Axle | Inspect |
| D | Tires / Wheels | Inspect tread depth, sidewall cracking, wear patterns |

20,000 MILES (32,000 KM) SERVICE

| ITEM | | REMARKS |
|------|------------------------------|---------------------------------|
| XU | Air Filter | Inspect; clean |
| D | Crankcase Ventilation System | Inspect; tighten, clean, adjust |

| ITEM | | REMARKS |
|--------|-------------------------------------|--|
| D | Drive Chain | Inspect; clean, lubricate |
| D | Chain Sliders | Inspect; replace as needed |
| D | Engine Compression | Inspect; correct if necessary |
| XU | Engine Oil & Filter Change | Change oil and filter, inspect used oil for contaminants |
| E | Evaporative Emission Control System | Inspect; clean |
| E | Exhaust System | Inspect; tighten, adjust |
| D | Fuel System | Inspect; clean |
| D | Oil Lines / Oil System Inspection | Inspect; clean, adjust if necessary |
| D / E | Spark Plugs | Inspect; replace as needed; torque to specification |
| D | Valve Lash Clearance | Inspect; adjust if necessary |
| | Battery | Check terminals; clean; test |
| D | Brake Fluid | Replace (DOT 4) |
| XU / D | Brake Pads | Inspect pad wear; replace if worn beyond service limit |
| D | Clutch Lever | Lubricate with proper lubricant as directed |
| D | Clutch Cable Freeplay | Inspect; adjust if necessary |
| D | Control Cable Ends | Lubricate with proper lubricant as directed |
| D | Fasteners | Inspect; tighten if necessary |
| D | Front Brake Lever | Adjust if necessary, lubricate with proper lubricant as directed |
| D | Front Fork Oil | Inspect |
| D | Front Forks and Front Axle | Inspect; adjust if necessary |
| D | Head Light | Inspect; adjust if necessary |

MAINTENANCE

| ITEM | | REMARKS |
|------|---------------------------|---|
| D | Gear Shift Pedal | Inspect; lubricate, adjust if necessary |
| D | Rear Brake Pedal | Inspect; lubricate, adjust if necessary |
| D | Driver and Passenger Pegs | Inspect; lubricate if necessary |
| D | Rear Shock Absorber | Inspect; adjust if necessary |
| D | Rear Wheel Alignment | Inspect; adjust if necessary |
| | Road Test | Perform Road Test |
| D | Sidestand | Lubricate with proper lubricant as directed |
| D | Steering Bearings | Inspect |
| D | Suspension Linkage, Rear | Inspect |
| D | Swing Arm and Rear Axle | Inspect |
| D | Tires / Wheels | Inspect tread depth, sidewall cracking, wear patterns |

25,000 MILES (40,000 KM) SERVICE

| ITEM | | REMARKS |
|------|-------------------------------------|-------------------------------------|
| XU | Air Filter | Inspect; clean |
| D | Crankcase Ventilation System | Inspect; tighten, clean, adjust |
| D | Drive Chain | Inspect; clean, lubricate |
| D | Chain Sliders | Inspect; replace as needed |
| E | Evaporative Emission Control System | Inspect; clean |
| E | Exhaust System | Inspect; tighten, adjust |
| D | Fuel System | Inspect; clean |
| D | Oil Lines / Oil System Inspection | Inspect; clean, adjust if necessary |

| ITEM | | REMARKS |
|--------|----------------------------|---|
| | Battery | Check terminals; clean; test |
| D | Brake Fluid | Change every two years (DOT 4) |
| XU / D | Brake Pads | Inspect pad wear; replace if worn beyond service limit |
| D | Clutch Lever | Inspect; adjust if necessary |
| D | Clutch Cable Freeplay | Inspect; adjust if necessary |
| D | Control Cable Ends | Inspect; adjust if necessary |
| D | Fasteners | Inspect; tighten if necessary |
| D | Front Brake Lever | Adjust if necessary, lubricate with proper lubricant as directed |
| D | Front Fork Oil | Inspect |
| D | Front Forks and Front Axle | Inspect; adjust if necessary |
| D | Gear Shift Pedal | Inspect; lubricate, adjust if necessary |
| D | Rear Brake Pedal | Inspect; lubricate, adjust if necessary |
| D | Driver and Passenger Pegs | Inspect; lubricate if necessary |
| D | Rear Shock Absorber | Inspect; adjust if necessary |
| D | Rear Wheel Alignment | Inspect; adjust if necessary |
| | Road Test | Perform Road Test |
| D | Sidestand | Inspect; adjust if necessary, lubricate with proper lubricant as directed |
| D | Steering Bearings | Inspect |
| D | Suspension Linkage, Rear | Inspect |
| D | Swing Arm and Rear Axle | Inspect |
| D | Tires / Wheels | Inspect tread depth, sidewall cracking, wear patterns |

MAINTENANCE

30,000 MILES (48,000 KM) SERVICE

| ITEM | | REMARKS |
|--------|-------------------------------------|--|
| XU | Air Filter | Replace |
| D | Crankcase Ventilation System | Inspect; tighten, clean, adjust |
| D | Drive Chain | Replace |
| D | Chain Sliders | Inspect; replace as needed |
| D | Engine Compression | Inspect; correct if necessary |
| XU | Engine Oil & Filter Change | Change oil and filter, inspect used oil for contaminants |
| E | Evaporative Emission Control System | Inspect; clean |
| E | Exhaust System | Inspect; tighten, adjust |
| D | Fuel System | Inspect; clean |
| D | Oil Lines / Oil System Inspection | Inspect; clean, adjust if necessary |
| D / E | Spark Plugs | Replace |
| | Battery | Check terminals; clean; test |
| D | Brake Fluid | Replace (DOT 4) |
| XU / D | Brake Pads | Inspect pad wear; replace if worn beyond service limit |
| D | Clutch Lever | Lubricate with proper lubricant as directed |
| D | Clutch Cable Freeplay | Inspect; adjust if necessary |
| D | Control Cable Ends | Lubricate with proper lubricant as directed |
| D | Fasteners | Inspect; tighten if necessary |
| D | Front Brake Lever | Lubricate with proper lubricant as directed |
| D | Front Fork Oil | Replace |

| ITEM | | REMARKS |
|------|----------------------------|---|
| D | Front Forks and Front Axle | Inspect; adjust if necessary |
| D | Head Light | Inspect; adjust if necessary |
| D | Gear Shift Pedal | Inspect; lubricate, adjust if necessary |
| D | Rear Brake Pedal | Inspect; lubricate, adjust if necessary |
| D | Driver and Passenger Pegs | Inspect; lubricate if necessary |
| D | Rear Shock Absorber | Inspect; adjust if necessary |
| D | Rear Wheel Alignment | Inspect; adjust if necessary |
| | Road Test | Perform Road Test |
| D | Sidestand | Lubricate with proper lubricant as directed |
| D | Steering Bearings | Inspect |
| D | Suspension Linkage, Rear | Inspect |
| D | Swing Arm and Rear Axle | Inspect |
| D | Tires / Wheels | Inspect tread depth, sidewall cracking, wear patterns |

35,000 MILES (52,000 KM) SERVICE

| ITEM | | REMARKS |
|------|-------------------------------------|---------------------------------|
| XU | Air Filter | Inspect; clean |
| D | Crankcase Ventilation System | Inspect; tighten, clean, adjust |
| D | Drive Chain | Inspect; clean, lubricate |
| D | Chain Sliders | Inspect; replace as needed |
| E | Evaporative Emission Control System | Inspect; clean |
| E | Exhaust System | Inspect; tighten, adjust |

MAINTENANCE

| ITEM | | REMARKS |
|--------|-----------------------------------|--|
| D | Fuel System | Inspect; clean |
| D | Oil Lines / Oil System Inspection | Inspect; clean, adjust if necessary |
| | Battery | Check terminals; clean; test |
| D | Brake Fluid | Change every two years (DOT 4) |
| XU / D | Brake Pads | Inspect pad wear; replace if worn beyond service limit |
| D | Clutch Lever | Inspect; adjust if necessary |
| D | Clutch Cable Freeplay | Inspect; adjust if necessary |
| D | Control Cable Ends | Inspect; adjust if necessary |
| D | Fasteners | Inspect; tighten if necessary |
| D | Front Brake Lever | Adjust if necessary, lubricate with proper lubricant as directed |
| D | Front Fork Oil | Inspect |
| D | Front Forks and Front Axle | Inspect; adjust if necessary |
| D | Gear Shift Pedal | Inspect; lubricate, adjust if necessary |
| D | Rear Brake Pedal | Inspect; lubricate, adjust if necessary |
| D | Driver and Passenger Pegs | Inspect; lubricate if necessary |
| D | Rear Shock Absorber | Inspect; adjust if necessary |
| D | Rear Wheel Alignment | Inspect; adjust if necessary |
| | Road Test | Perform Road Test |
| D | Sidestand | Lubricate with proper lubricant as directed |
| D | Steering Bearings | Inspect |
| D | Suspension Linkage, Rear | Inspect |

| ITEM | | REMARKS |
|------|-------------------------|---|
| D | Swing Arm and Rear Axle | Inspect |
| D | Tires / Wheels | Inspect tread depth, sidewall cracking, wear patterns |

40,000 MILES (64,000 KM) SERVICE

| ITEM | | REMARKS |
|--------|-------------------------------------|--|
| XU | Air Filter | Inspect; clean |
| D | Crankcase Ventilation System | Inspect; tighten, clean, adjust |
| D | Drive Chain | Inspect; clean, lubricate |
| D | Chain Sliders | Inspect; replace as needed |
| D | Engine Compression | Inspect; correct if necessary |
| XU | Engine Oil & Filter Change | Change oil and filter, inspect used oil for contaminants |
| E | Evaporative Emission Control System | Inspect; clean |
| E | Exhaust System | Inspect; tighten, adjust |
| D | Fuel System | Inspect; clean |
| D | Oil Lines / Oil System Inspection | Inspect; clean, adjust if necessary |
| D / E | Spark Plugs | Inspect; replace as needed; torque to specification |
| D | Valve Lash Clearance | Inspect; adjust if necessary |
| | Battery | Check terminals; clean; test |
| D | Brake Fluid | Replace (DOT 4) |
| XU / D | Brake Pads | Inspect pad wear; replace if worn beyond service limit |
| D | Clutch Lever | Lubricate with proper lubricant as directed |

MAINTENANCE

| ITEM | | REMARKS |
|------|----------------------------|--|
| D | Clutch Cable Freeplay | Inspect; adjust if necessary |
| D | Control Cable Ends | Lubricate with proper lubricant as directed |
| D | Fasteners | Inspect; tighten if necessary |
| D | Front Brake Lever | Adjust if necessary, lubricate with proper lubricant as directed |
| D | Front Fork Oil | Inspect |
| D | Front Forks and Front Axle | Inspect; adjust if necessary |
| D | Head Light | Inspect; adjust if necessary |
| D | Gear Shift Pedal | Inspect; lubricate, adjust if necessary |
| D | Rear Brake Pedal | Inspect; lubricate, adjust if necessary |
| D | Driver and Passenger Pegs | Inspect; lubricate if necessary |
| D | Rear Shock Absorber | Inspect; adjust if necessary |
| D | Rear Wheel Alignment | Inspect; adjust if necessary |
| | Road Test | Perform Road Test |
| D | Sidestand | Lubricate with proper lubricant as directed |
| D | Steering Bearings | Inspect |
| D | Suspension Linkage, Rear | Inspect |
| D | Swing Arm and Rear Axle | Inspect |
| D | Tires / Wheels | Inspect tread depth, sidewall cracking, wear patterns |

45,000 MILES (72,000 KM) SERVICE

| ITEM | | REMARKS |
|--------|-------------------------------------|--|
| XU | Air Filter | Replace |
| D | Crankcase Ventilation System | Inspect; tighten, clean, adjust |
| D | Drive Chain | Replace |
| D | Chain Sliders | Inspect; replace as needed |
| E | Evaporative Emission Control System | Inspect; clean |
| E | Exhaust System | Inspect; tighten, adjust |
| D | Fuel System | Inspect; clean |
| D | Oil Lines / Oil System Inspection | Inspect; clean, adjust if necessary |
| | Battery | Check terminals; clean; test |
| D | Brake Fluid | Change every two years (DOT 4) |
| XU / D | Brake Pads | Inspect pad wear; replace if worn beyond service limit |
| D | Clutch Lever | Lubricate with proper lubricant as directed |
| D | Clutch Cable Freeplay | Inspect; adjust if necessary |
| D | Control Cable Ends | Inspect; lubricate with proper lubricant as directed |
| D | Fasteners | Inspect; tighten if necessary |
| D | Front Brake Lever | Lubricate with proper lubricant as directed |
| D | Front Fork Oil | Replace |
| D | Front Forks and Front Axle | Inspect; adjust if necessary |
| D | Gear Shift Pedal | Inspect; lubricate, adjust if necessary |
| D | Rear Brake Pedal | Inspect; lubricate, adjust if necessary |

MAINTENANCE

| ITEM | | REMARKS |
|------|---------------------------|---|
| D | Driver and Passenger Pegs | Inspect; lubricate if necessary |
| D | Rear Shock Absorber | Inspect; adjust if necessary |
| D | Rear Wheel Alignment | Inspect; adjust if necessary |
| | Road Test | Perform Road Test |
| D | Sidestand | Lubricate with proper lubricant as directed |
| D | Steering Bearings | Inspect |
| D | Suspension Linkage, Rear | Inspect |
| D | Swing Arm and Rear Axle | Inspect |
| D | Tires / Wheels | Inspect tread depth, sidewall cracking, wear patterns |

50,000 MILES (80,000 KM) SERVICE

| ITEM | | REMARKS |
|------|-------------------------------------|--|
| XU | Air Filter | Inspect; clean |
| D | Crankcase Ventilation System | Inspect; tighten, clean, adjust |
| D | Drive Chain | Inspect; clean, lubricate |
| D | Chain Sliders | Inspect; replace as needed |
| D | Engine Compression | Inspect; correct if necessary |
| D | Engine Mount Fasteners | Inspect; tighten, adjust |
| XU | Engine Oil & Filter Change | Change oil and filter, inspect used oil for contaminants |
| E | Evaporative Emission Control System | Inspect; clean |
| E | Exhaust System | Inspect; tighten, adjust |
| D | Fuel System | Inspect; clean |

| ITEM | | REMARKS |
|--------|-----------------------------------|--|
| D | Oil Lines / Oil System Inspection | Inspect; clean, adjust if necessary |
| D / E | Spark Plugs | Inspect; replace as needed; torque to specification |
| | Battery | Check terminals; clean; test |
| D | Brake Fluid | Replace (DOT 4) |
| XU / D | Brake Pads | Inspect pad wear; replace if worn beyond service limit |
| D | Clutch Lever | Lubricate with proper lubricant as directed |
| D | Clutch Cable Freeplay | Inspect; adjust if necessary |
| D | Control Cable Ends | Lubricate with proper lubricant as directed |
| D | Fasteners | Inspect; tighten if necessary |
| D | Front Brake Lever | Adjust if necessary, lubricate with proper lubricant as directed |
| D | Front Fork Oil | Inspect |
| D | Front Forks and Front Axle | Inspect; adjust if necessary |
| D | Head Light | Inspect; adjust if necessary |
| D | Gear Shift Pedal | Inspect; lubricate, adjust if necessary |
| D | Rear Brake Pedal | Inspect; lubricate, adjust if necessary |
| D | Driver and Passenger Pegs | Inspect; lubricate if necessary |
| D | Rear Shock Absorber | Replace |
| D | Rear Wheel Alignment | Inspect; adjust if necessary |
| | Road Test | Perform Road Test |
| D | Sidestand | Lubricate with proper lubricant as directed |
| D | Steering Bearings | Inspect |

MAINTENANCE

| ITEM | | REMARKS |
|-------------|--------------------------|---|
| D | Suspension Linkage, Rear | Inspect |
| D | Swing Arm and Rear Axle | Inspect |
| D | Tires / Wheels | Inspect tread depth, sidewall cracking, wear patterns |

XU - Perform these procedures more often for vehicles subjected to severe use.

D - Have an authorized INDIAN MOTORCYCLE dealer perform these services.

E - Emission Control System Service (California)

ENGINE OIL & FILTER CHANGE

IMPORTANT

Engine **MUST BE WARMED** before performing the following procedure.



CAUTION

HOT COMPONENTS

Wear insulated gloves and use caution handling these parts.

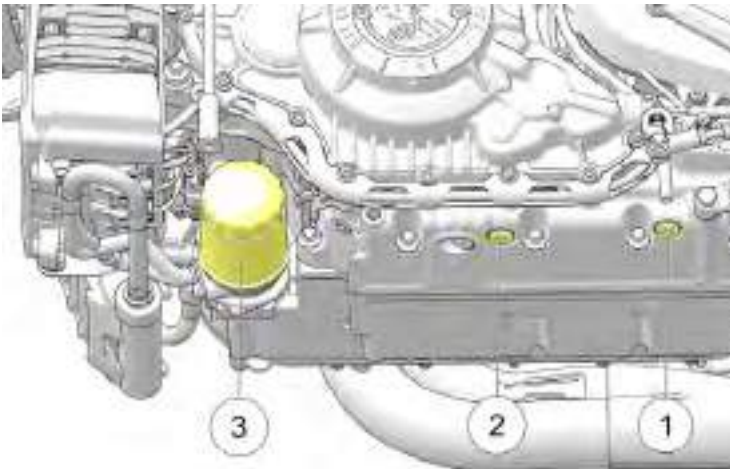

1. Run engine until warm, then turn engine off.
2. Securely support the motorcycle in a vertical “centered” position.
3. Place an oil drain pan under the engine oil drain plugs ① and ②.
4. Remove the drain plugs and sealing washers.
5. Allow oil to drain completely. Dispose of oil properly.
6. Remove oil filter ③ and allow oil to drain. Dispose of oil filter properly.
7. Clean the engine oil filter mount sealing surface and surrounding area.
8. Place a small amount of oil on the new oil filter seal and spin filter on until the filter seal contacts the sealing surface. Tighten oil filter to specification.

TORQUE

Oil Filter:

115 in-lbs (13 N·m) or approximately 3/4 to 1 full turn after seal contacts the filter mount sealing surface.

MAINTENANCE

9. Use new sealing washers and reinstall the drain plugs. Torque to specification.

TORQUE

Engine Oil Drain Plug:
15 ft-lbs (20 N·m)

10. Use a funnel to add 3 qt (2.8 L) of Indian Motorcycle 15W-60 Full Synthetic engine oil through the engine oil fill port.

NOTICE

3 US quarts will bring the engine oil level at or near the "FULL" mark on the sight glass. For a new or rebuilt (dry) engine add an additional 0.5 qt (0.47 L).

11. Securely support the motorcycle in a vertical "centered" position, idle engine for approximately 30 seconds.
12. Turn the engine off.
13. Inspect the oil level by looking at the oil sight glass. The oil level should be in the middle of the sight glass between the two indicator marks. **DO NOT OVERFILL!**

IMPORTANT

Total engine oil fill volume with oil filter change will be approximately 3.0 - 4.0 qt (2.8 - 3.8 L). Total engine oil fill volume with a new or rebuilt (dry) engine will be approximately 4.5 qt (4.25 L).

14. Refer to page 56 for setting proper oil level.

CAUTION

If the low oil pressure indicator remains illuminated longer than usual after an oil change, do not increase RPM above idle until indicator lamp goes out or engine may be damaged.

15. Check for leaks around drain plug and oil filter.

NOTICE

Recycle used oil and oil filter in accordance with local regulations.

COOLING SYSTEM

The engine coolant level is controlled by the recovery system. Recovery system components are the recovery bottle, the radiator filler neck, the radiator pressure cap and the connecting hose.

As coolant operating temperature increases, the expanding (heated) excess coolant is forced out of the engine, past the pressure cap, and into the recovery bottle. As engine coolant temperature decreases the contracting (cooled) coolant is drawn back up from the bottle, past the pressure cap, and into the radiator.

Some coolant level drop on new vehicles is normal as the system is purging itself of trapped air. Check the coolant level and maintain as recommended by adding coolant to the recovery bottle.

INDIAN MOTORCYCLE recommends the use of Antifreeze 50/50 Premix. This antifreeze is already premixed and ready to use. Do not dilute with water.

To ensure that the coolant maintains its ability to protect the engine, we recommend that the system be completely drained every five (5) years or 50,000 miles (80,467 km), whichever comes first. Please see your dealer for this service.

COOLANT LEVEL INSPECTION

The Coolant Overflow bottle is located under the airbox cover. The level can be viewed without the need to disassemble any components.

1. Locate the coolant bottle level window located on the left side of the unit.

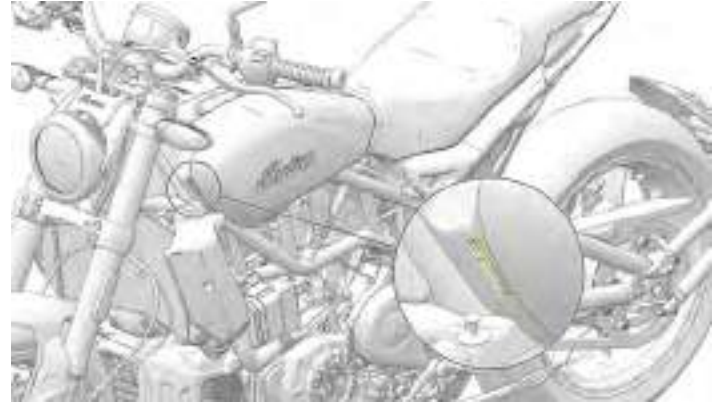

2. Ensure the coolant is in between the marked values.
3. If the coolant level is below the bottom line, coolant will need to be added to the system.

MAINTENANCE

ADDING COOLANT

To add coolant, do the following:

1. Remove the seat and airbox covers.
2. Remove the overflow bottle cap ① to add coolant. Add coolant until level is within the marked values.

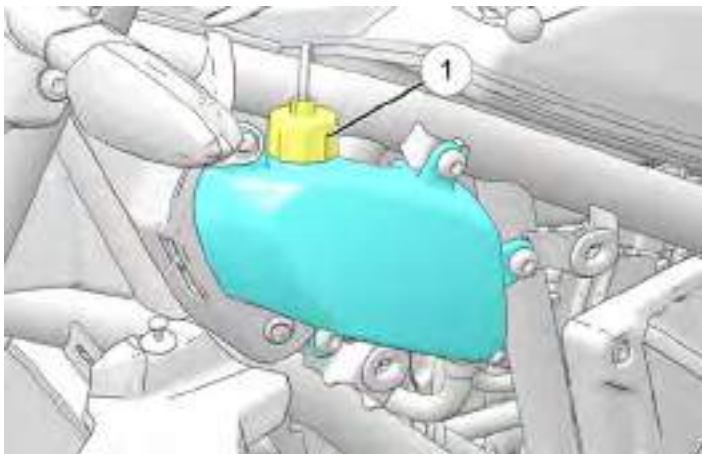

AIR FILTER REPLACEMENT

NOTICE

If the motorcycle is operated in wet or dusty conditions, more frequent servicing is required. The air filter element cannot be cleaned. Replace the filter when necessary.

1. Remove the seat. See page 131.
2. Remove four fasteners ① securing air box bezel.

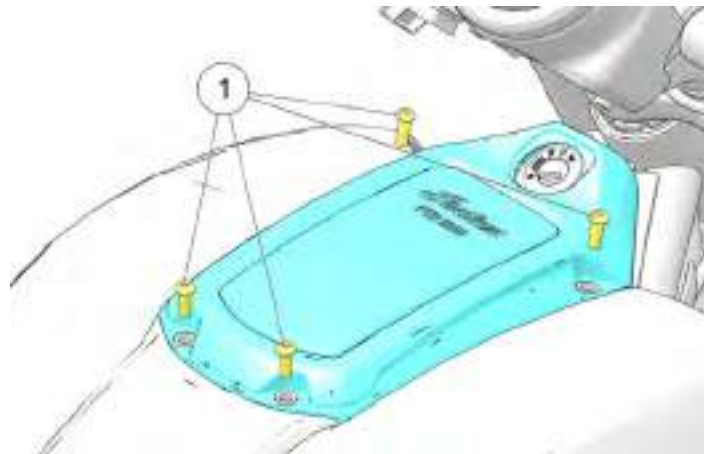

NOTICE

Do not loosen or reinstall fasteners without compression limiters in place.

3. Remove the center console cover from the alignment bracket.

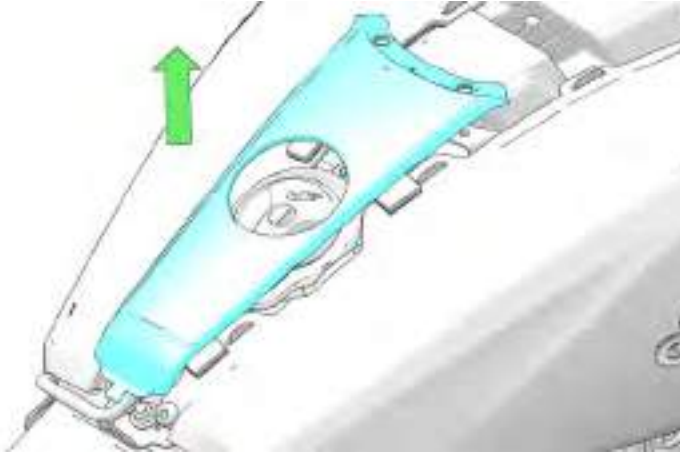

4. Remove the gas cap and relocate to clean, safe location.

5. Remove the two fasteners securing the air box cover ②.

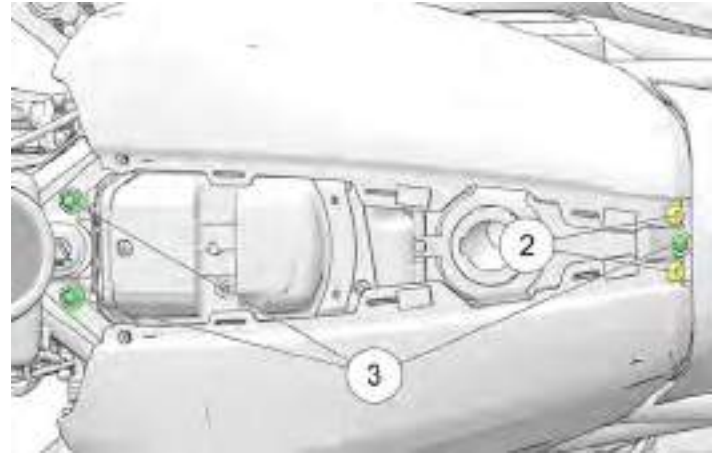

6. Remove the 2 air box covers.

NOTICE

Pull air box cover up and out to remove.

7. Remove three fasteners ③ to remove alignment bracket.

MAINTENANCE

8. Remove seven fasteners ④ securing air filter access cover.

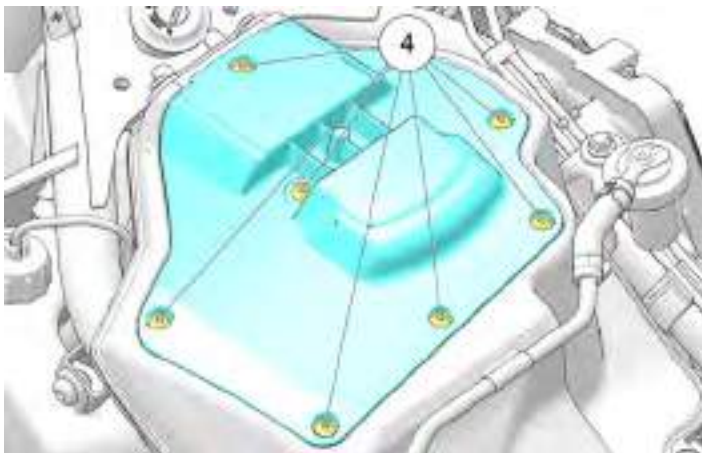

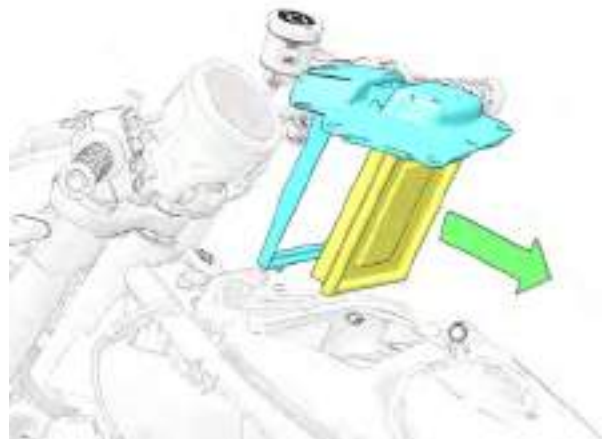

9. Remove the air filter from the airbox.

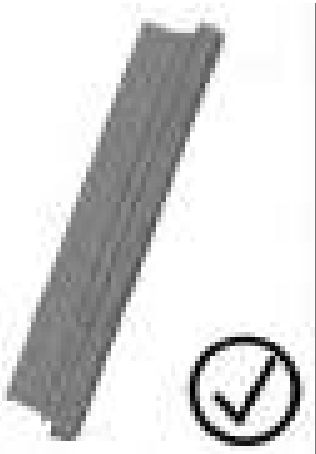

10. Inspect filter element and replace if dirty, wet, or oil fouled.

11. Install *New* filter with same orientation as old filter.

|  CAUTION | |
|--|---|
| <p>A bent, improperly installed filter element, or loose fitting cover may allow debris to enter the engine which may cause premature engine wear.</p> | |
|  |  |

12. Install air filter access cover and secure with seven fasteners.

| TORQUE |
|---|
| <p>Air Filter Access Cover Fastener: 14 in-lbs (2 N·m)</p> |

13. Install the alignment bracket and secure with fasteners.

| TORQUE |
|---|
| <p>Bodywork Alignment Bracket Fastener: 96 in-lbs (11 N·m)</p> |

14. Install airbox cover.

| TORQUE |
|--|
| <p>Airbox Cover Fastener: 36 in-lbs (4 N·m)</p> |

15. Install gas cap.

16. Install center console cover.

17. Install airbox bezel and secure with fasteners.

| TORQUE |
|--|
| <p>Airbox Bezel Fastener: 36 in-lbs (4 N·m)</p> |

18. Reinstall seat. See page 131

CHAIN TENSION

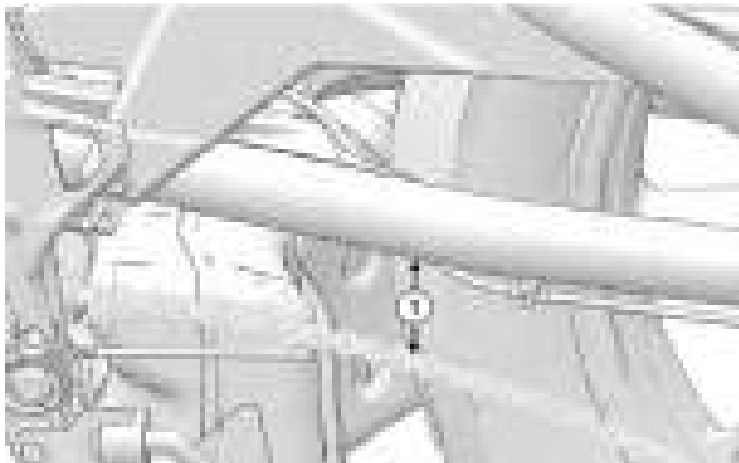

To measure the chain tension, do the following:

1. With motorcycle on side stand and in neutral, using a chain tension gauge push up on the lower string of the chain in the center with 10 lbs. of force.
2. Measure to the bottom of the swing arm behind the chain slider at the rear of the swing arm gusset ①.

MEASUREMENT

Distance to the top of the chain:

33–40 mm

3. If drive chain tension appears to be out of specification or misaligned, see page 107, or your authorized Indian Motorcycle dealer for maintenance and service recommendations.

DRIVE CHAIN STRETCH INSPECTION

With a 20-25 lb weight hung on the lower string of the chain, measure the distance from the center of one pin to the center of the 21st pin on the top string of the chain. If the length exceeds 319 mm, chain must be replaced.

DRIVE CHAIN TENSION - SPECIFICATIONS

| CHAIN DEFLECTION | |
|-----------------------------------|----------------------------|
| MODEL | DEFLECTION AT 10 LBS FORCE |
| All Models | 33–40 mm |
| DRIVE CHAIN STRETCH SPECIFICATION | |
| MODEL | Value |
| All Models | 319 mm or less |

DRIVE CHAIN ADJUSTMENT

Lubricate the drive chain with INDIAN MOTORCYCLE chain spray lube or an approved chain lube at the interval specified in the Periodic Maintenance Chart. Lubricate more often under severe use, such as dirty or wet conditions.

IMPORTANT

Washing the drive chain with a high pressure washer or solvents can cause premature wear and chain failure. Do not use a high pressure washer or gasoline to clean the drive chain. Operating the motorcycle with improper rear drive chain deflection can result in severe damage to the transmission and drive components. Always make sure the chain is adjusted within the stated specifications.

WARNING

A rear axle not in alignment can cause drive line noise and damage the drive chain, causing possible chain failure and loss of control of the motorcycle.

MAINTENANCE

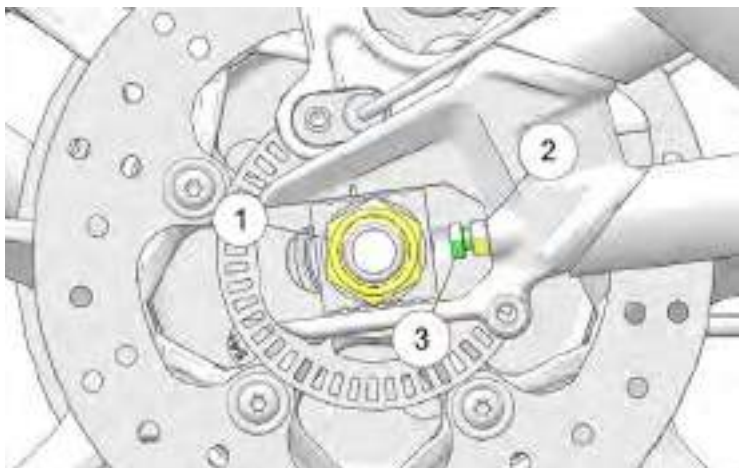

1. Loosen the axle nut ①.
2. Loosen both tension bolt jam nuts ② on both sides.
3. Adjust the tension bolts ③ evenly on both sides until correct tension is achieved. Reference page 107.

IMPORTANT

To minimize change in chain tension, use RIGHT SIDE adjuster only to make final adjustments to chain alignment. Be sure to keep axle seated forward against axle adjusters during this procedure.

4. Use the adjuster marks to ensure even axle alignment.
5. Without moving the tension bolts, Tighten jam nuts. Ensure the axle is pushed forward against the adjuster bolts.

TORQUE

Swing arm Jam Nut
12 ft-lbs (16 N·m)

6. Recheck chain tension and adjust accordingly.
7. Install axle nut.

TORQUE

Axle Nut (Rear)
92 ft-lbs (125 N·m)

REAR SHOCK PRELOAD INSPECTION

Periodically inspect rear shock preload. For the most comfortable ride and proper ground clearance, adjust preload according to following table.

NOTICE

Models shown for reference only. Shock may vary depending on model.



1. Identify the combined weight of rider, passenger, and cargo.
2. Determine shock preload by measuring the amount of exposed thread on the shock body behind the jam nut. See the table below for measurement based on weight.
3. Adjust preload as needed to achieve dimension specified in the table below. To adjust, See page 110.

| COMBINED WEIGHT OF RIDER, PASSENGER, AND CARGO | DIMENSION | | |
|--|-----------|-------------|--------------|
| | FTR RALLY | FTR / FTR S | FTR R CARBON |
| 125 lb (57 kg) | 0 mm | 0 mm | 19 mm |
| 150 lb (68 kg) | 2 mm | 2 mm | 21 mm |
| 175 lb (79 kg) | 5 mm | 5 mm | 23.5 mm |
| 200 lb (91 kg) | 8 mm | 8 mm | 26 mm |
| 225 lb (102 kg) | 10 mm | 10 mm | 28 mm |
| 250 lb (113 kg) | 13 mm | 13 mm | 31 mm |
| 275 lb (125 kg) | 15 mm | 16 mm | 32 mm |
| 300 lb (136 kg) | 17 mm | 18 mm | 34 mm |

MAINTENANCE

| COMBINED WEIGHT OF RIDER, PASSENGER, AND CARGO | DIMENSION | | |
|--|-----------|-------------|--------------|
| | FTR RALLY | FTR / FTR S | FTR R CARBON |
| 325 lb (147 kg) | 20 mm | 21 mm | 37 mm |
| 350 lb (159 kg) | 22 mm | 23 mm | 39 mm |
| 375 lb (170 kg) | 25 mm | 26 mm | 39.5 mm |
| 400 lb (181 kg) | 27 mm | 28 mm | 39.5 mm |
| 425 lb (196 kg) | 30 mm | 30 mm | 39.5 mm |

REAR SHOCK PRELOAD ADJUSTMENT

1. Place the motorcycle in an upright position with the front wheel clamped in a wheel vise.
2. Using shock spanner wrench (**2884176**) loosen the lock nut ① by turning it counter-clockwise (as viewed from the top of the shock).
3. Spray a light lubricant on the adjuster nut where it contacts the spring.

4. Adjust shock preload by rotating the adjuster nut clockwise (as viewed from the top of the shock) to **INCREASE** preload (firm) or counter-clockwise to **DECREASE** preload (softer).

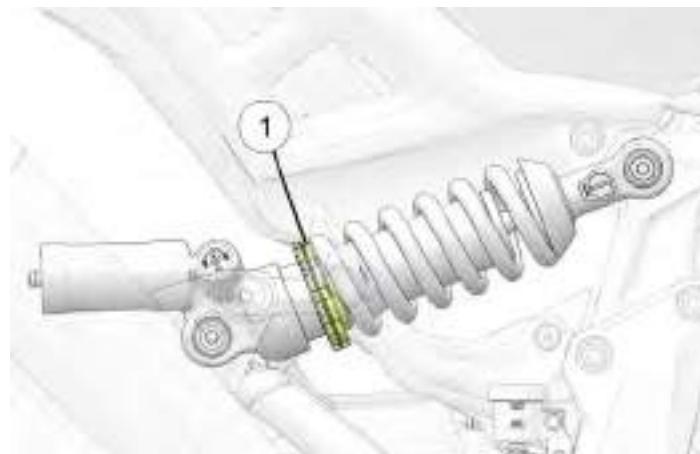

5. Recheck the preload measurement after adjusting.
6. Tighten the lock nut securely against the adjuster nut.

REAR SHOCK ADJUSTMENT GUIDE

IMPORTANT

Make sure rear shock preload is set correctly before changing compression and rebound settings below.

FTR / FTR RALLY / FTR S REBOUND SETTINGS

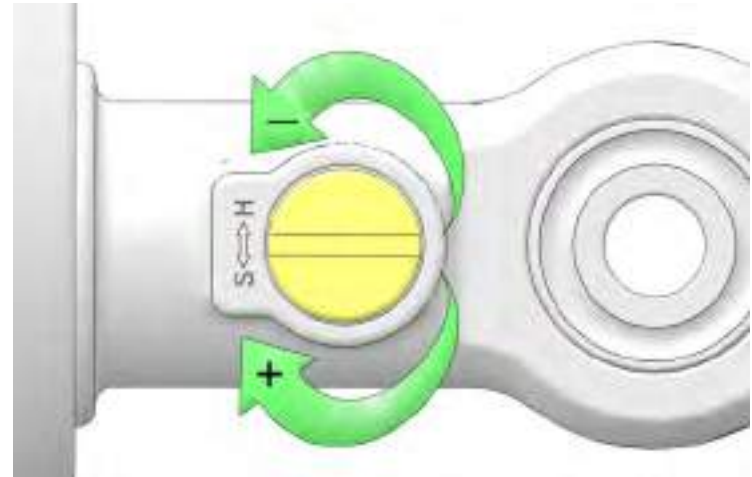

| RIDING TYPE: | SHOCK REBOUND | SHOCK COMPRESSION |
|-------------------------------|----------------------|--------------------------|
| Low Speed Riding (Urban) | 19 clicks out | 2.5 turns out |
| General Riding (Town/Highway) | 15 clicks out | 1.5 turns out |

NOTICE

FTR Rally features a preload and rebound adjustments on the rear shock but no fork adjustments.

FTR / FTR S features a fully adjustable fork and rear suspension components.

FTR R Carbon features a fully adjustable fork and rear suspension components.

NOTICE

Turning adjusters fully clockwise (+) will result in a “full-in” position. While turning adjustments fully counter-clockwise (-) will result in a “full-out” position.

REAR SHOCK FACTORY SETTING

| | FTR RALLY | FTR FTR S | FTR R CARBON |
|---|---|---|---|
| Shock Rebound, upper end of shock | 15 clicks out (from full-in, 24 clicks total) | 17 clicks out (from full-in, 24 clicks total) | 14 clicks out (from full-in, 40 clicks total) |
| Shock Compression, reservoir end of shock | N/A | 1.5 turns out (from full-in, 3 turns total) | 15 clicks out (from full-in, 22 clicks total) |
| Shock Spring Ends Installed Length | 180 mm (range 185 - 155 mm) | 174 mm (range 179 - 149 mm) | 168 mm (range 180 - 152 mm) |

MAINTENANCE

| RIDING TYPE: | SHOCK REBOUND | SHOCK COMPRESSION |
|---------------------------|---------------|-------------------|
| General Riding (2-up) | 5 clicks out | 1 turns out |
| Aggressive Riding (Track) | 5 clicks out | 0.75 turns out |

FTR / FTR S COMPRESSION DAMPING SETTINGS

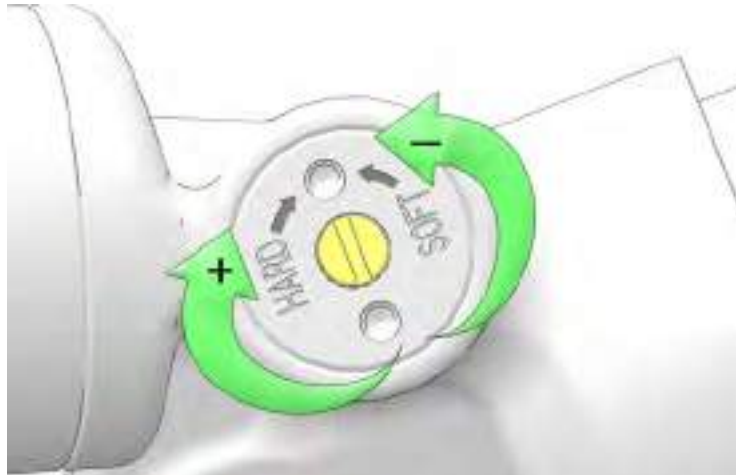

FTR R CARBON REBOUND SETTINGS

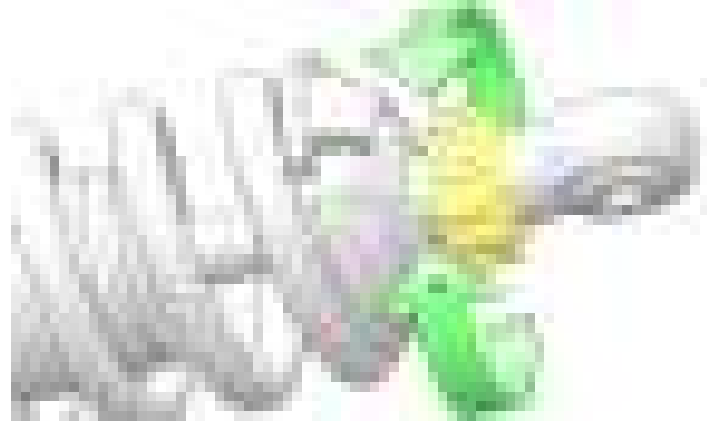

| RIDING TYPE: | SHOCK COMPRESSION | SHOCK REBOUND |
|-------------------------------|-------------------|---------------|
| Low Speed Riding (Urban) | 20 clicks out | 17 clicks out |
| General Riding (Town/Highway) | 15 clicks out | 14 clicks out |
| General Riding (2-up) | 13 clicks out | 12 clicks out |
| Aggressive Riding (Track) | 12 clicks out | 14 clicks out |

FTR R CARBON COMPRESSION DAMPING SETTINGS



SWING ARM/REAR AXLE INSPECTION

1. Sit in the operator's seat and slowly bounce the rear suspension a few times. Make sure the suspension moves freely without binding. Listen for abnormal noises.
2. Elevate and support the motorcycle with the rear tire slightly off the floor. See the Elevating the Motorcycle section for details.

⚠ CAUTION

Make sure the motorcycle is stable when elevated. Personal injury and/or damage to the vehicle may occur if the motorcycle tips or falls.

3. Grasp the rear wheel and attempt to move the wheel side-to-side. If there is movement at the front of the swingarm or in the axle area, see your dealer for service.
4. With the transmission in neutral, slowly rotate the rear wheel. If the wheel does not rotate smoothly, see your dealer for service.

FRONT FORK/SUSPENSION INSPECTION

1. Place the motorcycle on the sidestand and inspect the front forks. If fork oil is present on the outer tube ①, *do not ride the motorcycle*. See your dealer for service before operating. If fork oil is present around the fork seals ② or inner tubes ③, replace the fork seals.

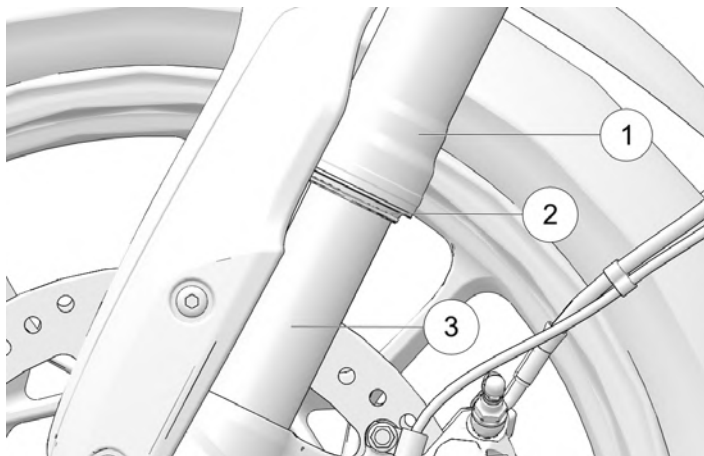

2. Clean the fork tubes to remove bugs, tar or buildup which may cause seal wear or leakage. Inspect the outer surfaces of the inner fork tubes for scratches or damage from foreign objects.

3. Straddle the motorcycle and bring it to the fully upright position. Apply the front brake and push downward (hard) on the handlebars several times. The front suspension should operate smoothly and quietly.
4. Fork oil condition and level affects front suspension performance and internal component wear. Replace fork oil at the recommended intervals. Special tools are required to perform this procedure. See the *INDIAN MOTORCYCLE Service Manual* or an authorized INDIAN MOTORCYCLE dealer or other qualified dealer.

FRONT FORK ADJUSTMENT GUIDE

NOTICE

FTR Rally features a preload and rebound adjustments on the rear shock but no fork adjustments.

FTR / FTR S features a fully adjustable fork and rear suspension components.

FTR R Carbon features a fully adjustable fork and rear suspension components.

NOTICE

Turning adjusters fully clockwise (+) will result in a “full-in” position. While turning adjustments fully counter-clockwise (-) will result in a “full-out” position.

FRONT FORK FACTORY SETTINGS

| | FTR RALLY | FTR FTR S | FTR R CARBON |
|---------------------------------------|------------------|---|---|
| Fork Rebound, right side screw slot | N/A | 10 clicks (<i>out from full-in, 20 click range total</i>) | 16 clicks (<i>out from full-in, 28 click range total</i>) |
| Fork Compression, left side screw lot | N/A | 10 clicks (<i>out from full-in, 20 click range total</i>) | 18 clicks (<i>out from full-in, 28 click range total</i>) |
| Fork Preload, 19 mm hex | N/A | 3 turns (<i>in from full-out, 10 turn range total</i>) | 9 turns (<i>in from full-out, 10 turn range total</i>) |

MAINTENANCE

FTR / FTR S RECOMMENDED DAMPING SETTINGS



| RIDING TYPE: | COMPRESSION (LEFT-HAND FORK) | REBOUND (RIGHT-HAND FORK) |
|----------------------------------|------------------------------------|---------------------------------|
| Low Speed Riding (Urban) | 17 clicks out | 14 clicks out |
| General Riding (Town/Highway) | 10 clicks out | 7 clicks out |

| RIDING TYPE: | COMPRESSION (LEFT-HAND FORK) | REBOUND (RIGHT-HAND FORK) |
|------------------------------|------------------------------------|---------------------------------|
| General Riding (2- up) | 10 clicks out | 5 clicks out |
| Aggressive Riding (Track) | 5 clicks out | 4 clicks out |

FTR / FTR S RECOMMENDED PRE-LOAD SETTINGS



Adjustments can be made to the fork to increase or decrease pre-load for a personal rider preference.

| |
|---|
| IMPORTANT |
| Make sure both forks are adjusted evenly. |

FTR R CARBON RECOMMENDED DAMPING SETTINGS

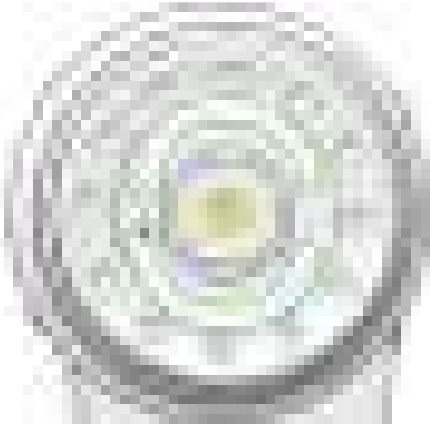

| RIDING TYPE: | COMPRESSION (LEFT-HAND FORK) | REBOUND (RIGHT-HAND FORK) |
|----------------------------------|---|--|
| Low Speed Riding (Urban) | 22 clicks out | 18 clicks out |
| General Riding (Town/Highway) | 18 clicks out | 16 clicks out |
| General Riding (2- up) | 15 clicks out | 14 clicks out |
| Aggressive Riding (Track) | 14 clicks out | 19 clicks out |

FTR R CARBON RECOMMENDED PRE-LOAD SETTINGS



Adjustments can be made to the fork to increase or decrease pre-load for a personal rider preference.

IMPORTANT

Make sure both forks are adjusted evenly.

STEERING HEAD INSPECTION

1. Elevate and support the motorcycle with the front tire slightly off the floor. See the Elevating the Motorcycle section for details.

CAUTION

Make sure the motorcycle is stable when elevated. Injury may occur if the motorcycle tips or falls.

2. Turn the handlebars from stop to stop. The action should be smooth but not loose. Make sure wires, hoses and control cables do not interfere with smooth steering.
3. Position the front wheel straight ahead. Grasp the front forks near the front axle and attempt to move the wheel front-to-back. If there is front-to-back movement at the steering head, see your dealer for service.
4. If steering binds, feels rough or uneven, or if movement is detected at the steering stem, see your dealer for service.
5. Rotate the front wheel and inspect for smooth rotation of front wheel bearings. If roughness or unusual sounds are present, see your dealer for service.
6. Turn handle bars full right or left and hold against the fork stop. Attempt to move front wheel side-to-side. If movement is observed, see your dealer for service.

FUEL SYSTEM COMPONENTS

1. Inspect fuel hoses for cracks or damage.
2. Inspect hose connections at the fuel tank and at the fuel rail for dampness or stains from leaks.
3. The fuel system is under pressure and caution must be used when inspecting and servicing the fuel system. See the *INDIAN MOTORCYCLE Service Manual* or an authorized *INDIAN MOTORCYCLE* dealer or other qualified dealer.

CRANKCASE BREATHER HOSES

Inspect the crankcase breather (vent) hoses ① each time the fuel tank is removed to perform air filter service or other maintenance. Inspect both breather hoses along their length and at both ends. Make sure hoses are not restricted, kinked, cracked or otherwise damaged. Replace any worn or damaged hoses.

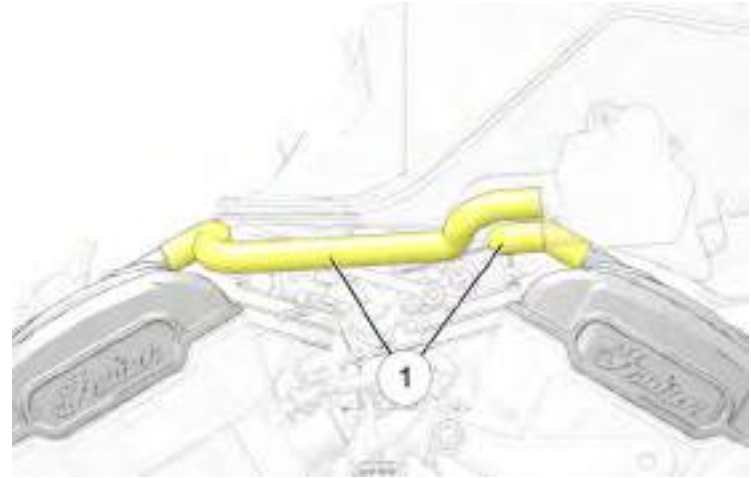

THROTTLE CONTROL INSPECTION

1. With the engine OFF, rotate the throttle control grip fully open and then release it. It should rotate smoothly from the rest position to the completely open position. It should return to the rest position quickly when released.
2. Repeat the twist and release process with the handlebars turned fully *right* and fully *left*.
3. Service the throttle system if throttle operation is not smooth or if throttle grip does not return properly. See the *INDIAN MOTORCYCLE Service Manual* or an authorized *INDIAN MOTORCYCLE* dealer or other qualified dealer.

MAINTENANCE

EVAPORATIVE EMISSION CONTROL SYSTEM

IMPORTANT

The fuel tank vent line is routed to a vapor canister where the fuel vapor is stored until specific operating parameters are met and the ECM opens the purge valve. Fuel vapor is then routed out of the vapor canister, through the purge valve and into the throttle body for combustion. Inspect all EVAP lines for abrasion or wear.

Check that all connections for both vent and canister purge systems are securely attached.

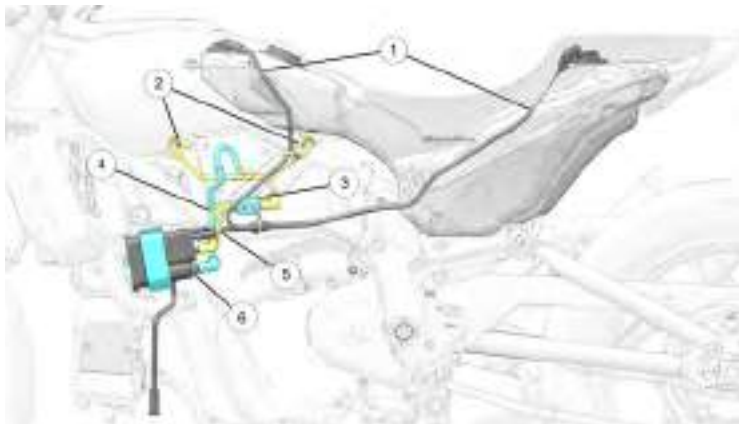

| NUMBER | DESCRIPTION |
|--------|--|
| ① | Fuel Tank Vent Hose |
| ② | Purge Hose (Purge Valve to Throttle Body) |
| ③ | Canister Purge Valve |
| ④ | Evaporative Emissions Vapor Canister Vent Hose |
| ⑤ | Purge Hose (Canister to Purge Valve) |
| ⑥ | Evaporative Emissions Vapor Canister |

MECHANICAL CLUTCH LEVER FREE PLAY

1. With handlebars pointing straight ahead, measure the clutch lever free play at point shown ① between lever and perch.

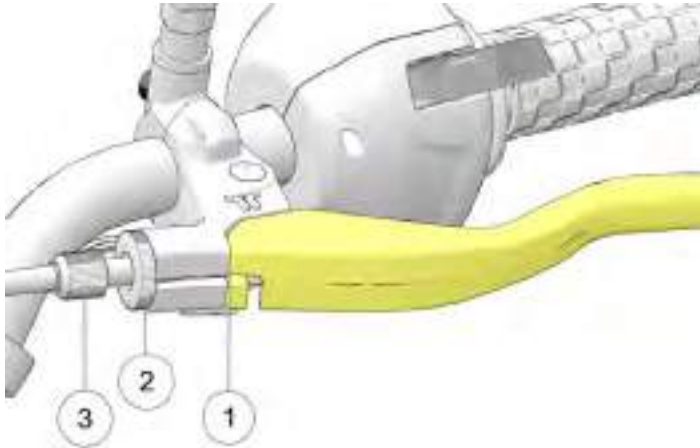

MEASUREMENT

Clutch Lever Free Play:
.019–.059 in (0.5–1.5 mm)

2. Compare measurement to specification. If adjustment is required, proceed to Step 3.
3. Locate the jam nut ② and barrel adjuster ③.

4. Hold cable and loosen the adjuster jam nut.
5. Turn cable adjuster in or out until clutch free play is correct.
6. Hand-tighten adjuster jam nut.

CLUTCH LEVER LUBRICATION

NOTICE

The clutch cable is factory-lubricated. Additional lubrication could be detrimental to cable performance. Replace the clutch cable assembly if binding or sticking occurs. **DO NOT** lubricate between the cable and sheath.

1. Disconnect clutch cable at primary cover.
2. Pull cable housing out of lever perch and remove barrel from clutch lever. Verify proper routing and smooth movement. Inspect for damage to the external casing, and inspect exposed cable wire for fraying, kinks or corrosion. Replace any damaged, sticky or sluggish cable.

MAINTENANCE

3. Remove the pivot bolt cap ①, nut ③ and push pivot bolt ② upward to remove.

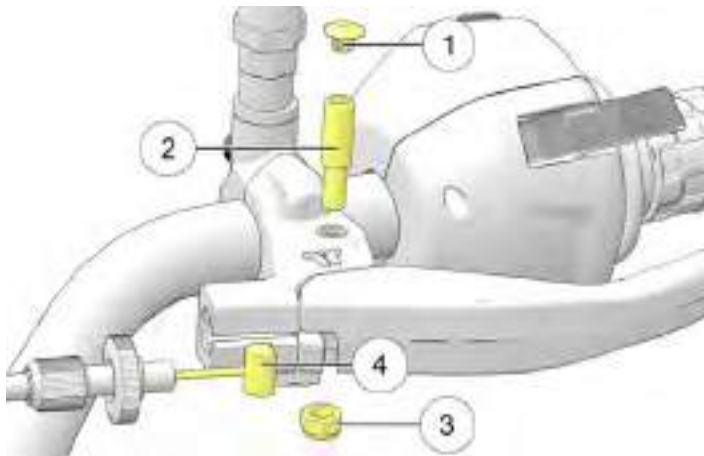

4. Inspect both ends of inner cable for frayed strands. Clean parts and apply all-purpose grease to pivot bolt.
5. Lubricate the barrel ends ④ with all-purpose grease.

NOTICE

Lubricate control cable barrel ends at the intervals recommended in the Periodic Maintenance Table on page 79.

6. Assemble lever.

7. Install cable to lever. Rotate cable back through slot in perch, and push outer casing back into perch recess.
8. Install the pivot bolt and torque the nut to specification.

TORQUE

Clutch Lever Pivot Nut:
49 in-lbs (5.5 N·m)

9. Lubricate and attach lower end of cable to clutch arm on primary cover.
10. Adjust clutch lever free play.

SIDE STAND LUBRICATION

Periodically lubricate the side stand bushing. See page 63 for side stand inspections.

REAR BRAKE PEDAL

1. Lubricate the pivot bushing at the intervals recommended in the Periodic Maintenance Table on page 79. Also lubricate any time binding is evident. Use all-purpose grease.
2. Inspect brake pads as outlined in the Brake Disc Inspection / Cleaning section.

BRAKE HOSES/CONNECTIONS

Inspect all brake hoses and connections for dampness or stains from leaking or dried fluid. Tighten any leaking connections and replace components as necessary. See the *INDIAN MOTORCYCLE Service Manual* or an authorized INDIAN MOTORCYCLE dealer or other qualified dealer.

BRAKE FLUID PRECAUTIONS



Clean filler cap before removing. Use only DOT 4 brake fluid from a sealed container. Using the wrong fluid or allowing air or contaminants into the fluid system can damage the system seals or result in a malfunction that could lead to serious injury or death.

Do not operate the front brake with the reservoir cover removed. Fluid could overflow from the reservoir and allow air to enter the system. Air in the brake system could cause the brakes to malfunction.

An over-full reservoir may cause brake drag or brake lock-up, which could result in serious injury or death. Maintain brake fluid at the recommended level. Do not overfill.

NOTICE

Brake fluid will damage painted surfaces and plastic parts. Always clean spilled brake fluid immediately with water and a mild detergent.

REAR BRAKE FLUID

Change the brake fluid at the intervals recommended in the Periodic Maintenance Table on page 79. Always add brake fluid from a new, unopened container. Always use the recommended fluid. See page 158.

1. Position the motorcycle on level ground in the fully upright position.
2. The rear brake fluid reservoir is located near the rear brake pedal. View the reservoir from the right side of the vehicle.
3. Wipe the fluid container and the area around the reservoir cover with a clean cloth.
4. If the fluid level is low, inspect brake pads as outlined on page 127. If pads are not worn beyond the service limit, inspect the brake system for leaks.

MAINTENANCE

5. Remove the cover and diaphragm. The fluid level should be above the minimum indicator mark on the reservoir body ①. Add brake fluid as needed. *Do not overfill.*

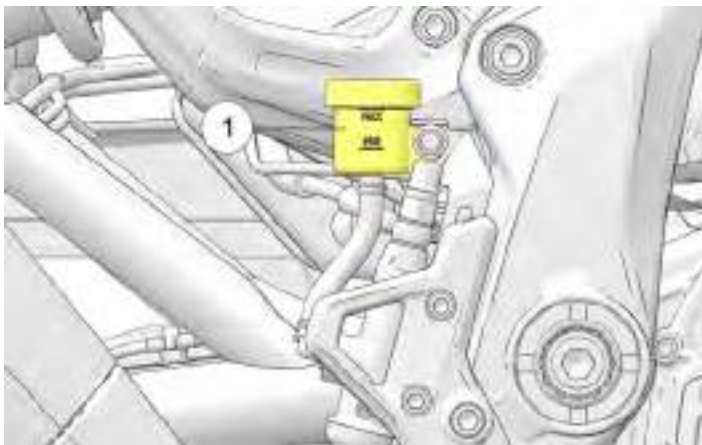

6. Reinstall the cover and diaphragm. Hand-tighten cover.
7. Wipe away any fluid spills. Check for signs of brake fluid leaks around hoses, fittings, reservoir, and brake calipers.

FRONT BRAKE LEVER

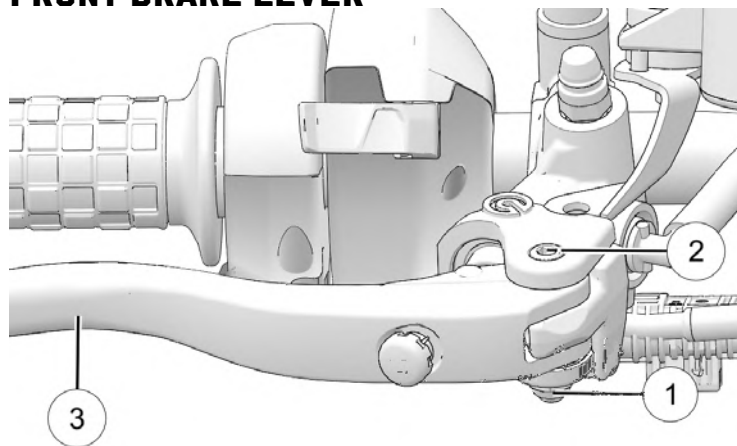

1. Remove the nut ① and pivot fastener ②.
2. Clean pivot bolt, lever and lever perch.
3. Remove brake lever and apply grease to pivot fastener ②, lever bushing, and pushrod contact surface of lever ③ as shown.

4. Assemble brake lever.
5. Torque brake lever pivot fastener nut to specification.

TORQUE

Brake Lever Pivot Fastener:
52 in-lbs (6 N·m)

FRONT BRAKE FLUID

Change the brake fluid at the intervals recommended in the *Periodic Maintenance Table* section.

Do not attempt to change the anti-lock brake system fluid. Please see your dealer for this service.

Always add brake fluid from a new, unopened container. Always use the recommended fluid. See page 158.

1. Position the motorcycle on level ground in the fully upright position. Position the handlebars so that the fluid reservoir is level. Wipe the fluid container and the area around the reservoir cover with a clean cloth.



2. View front brake fluid level through the fluid reservoir. The fluid should be clear and between the MIN ① and MAX ② markings. If the fluid level is low, inspect brake pads as outlined on page 126. If pads are not worn beyond the service limit, inspect the brake system for leaks.

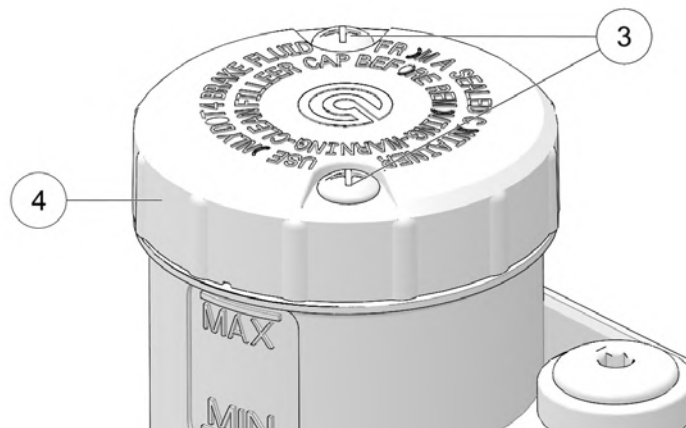

3. To add fluid, remove cover screws ③, reservoir cover ④.
4. Add DOT 4 brake fluid as needed to bring level to between the MIN ① and MAX ② markings. *Do not overfill.*
5. Reinstall the reservoir cover and torque screws to specification.

TORQUE

Front Master Cylinder Cap Screws:
13 in-lbs (1.4 N·m)

6. Wipe away any fluid spills. Check for signs of brake fluid leaks around hoses, fittings, reservoir and brake calipers. Check for deterioration of hoses.

FRONT BRAKE PAD INSPECTION

NOTICE

Wear indicator grooves are provided on each front brake pad to allow for a visual inspection without pad removal. Inspect pads by viewing from rear of caliper. Replace pads if worn to bottom of grooves.

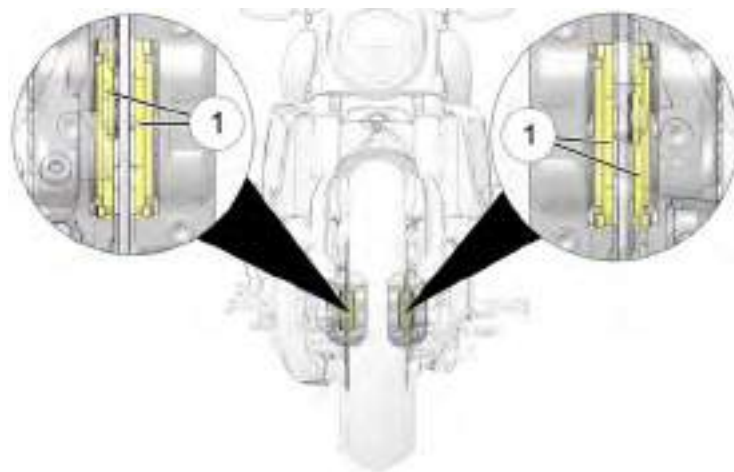

1. Viewing the front brake pads from the front of the calipers, locate the wear indicator grooves ①.
2. Wear indicator grooves should be visible on both inboard and outboard brake pads.

⚠ CAUTION

Front brake pads should always be replaced as a complete set. If it is determined that an individual brake pad has worn past the wear indicator groove, the front caliper should receive a new pad set. Failure to replace both front brake pads together may cause reduced braking performance or brake failure, resulting in a vehicle crash.

REAR BRAKE PAD INSPECTION

NOTICE

Wear indicator grooves are provided on each rear brake pad to allow for a visual inspection without pad removal. Inspect pads by viewing from the rear of the motorcycle, directly behind the muffler. Replace pads if worn to bottom of grooves.

1. Place the motorcycle in an upright position with the front wheel clamped in a wheel vise.
2. Viewing the rear brake pads from behind the motorcycle and below the lip of the rear fender, locate the wear indicator grooves ①.

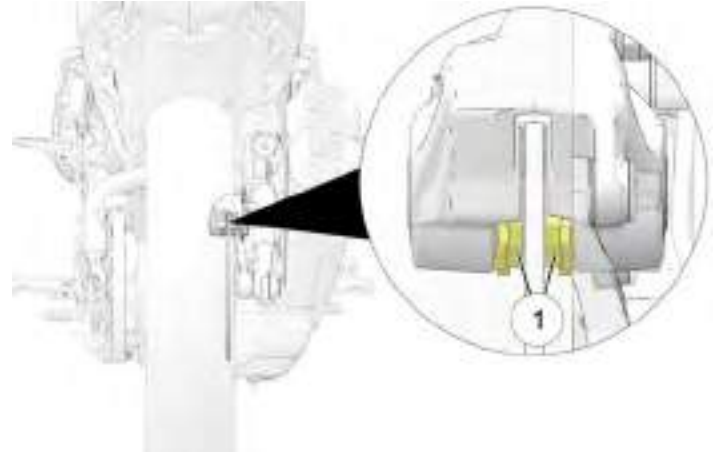

3. Wear indicator grooves should be visible on both inboard and outboard brake pads.

BRAKE DISC INSPECTION/CLEANING

1. Inspect brake discs ① for nicks, scratches, cracks or other damage. Inspect the thickness of each brake disc at four or more locations around the disc. If any disc is worn to the minimum thickness of 0.18 in (4.5 mm) at the thinnest point, or if a disc is damaged, see your dealer for replacement.

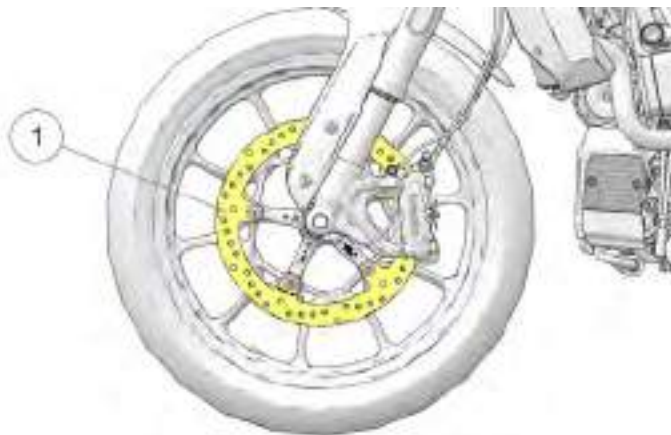

2. Clean discs if minor squeaks develop due to dirt or dust. Apply brake cleaner to a clean shop towel and wipe the discs. DO NOT allow brake cleaner to contact painted or plastic parts. Read all precautions on the label.

WHEEL INSPECTION

Inspect both wheels for cracks or damage and replace damaged wheels promptly. Do not operate the motorcycle if wheels are damaged or cracked. See the *INDIAN MOTORCYCLE Service Manual* or an authorized INDIAN MOTORCYCLE dealer or other qualified dealer.

WHEEL ALIGNMENT

Inspect rear wheel alignment at regular service intervals, whenever the rear wheel is removed and when the rear drive chain is adjusted. Please see your dealer for this service.

FRONT WHEEL REMOVAL / INSTALLATION

WARNING

This procedure requires raising and supporting the motorcycle so that the front wheel is off the ground. Precautions should be taken to ensure the motorcycle is properly stabilized at all times. Failure to properly support motorcycle may result in serious injury or damage to the motorcycle.

CAUTION

Do not twist the brake hose or brake line. Do not allow calipers to hang from the brake hose. Secure calipers in such a way to avoid hose damage.

1. Secure the motorcycle in an upright position with tie-down straps and a platform jack positioned beneath the engine cases.

IMPORTANT

Do not operate the front brake lever with the calipers or wheel removed.

REMOVAL

2. Remove front brake calipers.
3. Loosen axle pinch bolts ① on lower right fork leg.

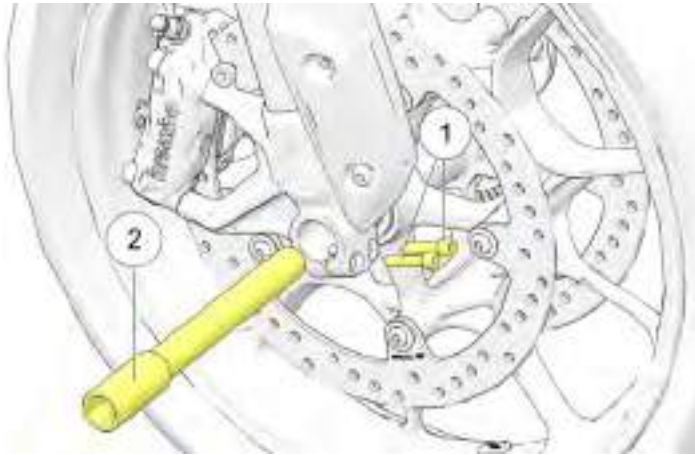

4. Support wheel and remove axle ② with 22 mm hex drive. Spacers are loosely retained by the dust seals, but may fall out after wheel has been removed.

INSTALLATION

5. Install front wheel and spacers into fork.
6. Install the axle and torque to specification.

TORQUE

Axle (front fork):
55 ft-lbs (75 N·m)

7. Cycle the front suspension. Tighten axle pinch bolts to specification.

TORQUE

Axle Pinch Fasteners:
14 ft-lbs (19 N·m)
Tighten each screw once after initial torque

8. Reinstall front brake calipers.

TIRES

WARNING

Operating the motorcycle with incorrect tires, incorrect tire pressure or excessively worn tires could cause loss of control or serious injury. Underinflation can cause a tire to overheat and result in a tire failure. Only use tires approved by INDIAN MOTORCYCLE for the model of the motorcycle. See your dealer. Use of unapproved or an improperly mixed front and rear tire can result in decreased handling performance and stability, potentially leading to reduced control of the motorcycle. Always maintain proper tire pressure as recommended in the rider's manual and on safety labels.

TIRE REPLACEMENT

Tires, rims, and air valves must be correctly matched to wheel rims. Only use tires approved by INDIAN MOTORCYCLE for the model of the motorcycle. See your dealer. Use of unapproved or an improperly mixed front and rear tire can result in decreased handling performance and stability, potentially leading to reduced control of the motorcycle. INDIAN MOTORCYCLE-recommended tires provide proper clearance between fenders, swingarm, drive chain and other components. See the Specifications section for details.

WARNING

Mismatched tires, rims and air valves may result in damage to the tire bead during mounting or may allow the tire to slip off the rim, possibly resulting in tire failure.

TIRE CONDITION

Inspect the tire sidewalls, road contact surface, and tread base for cuts, punctures, and cracking. Replace damaged tires immediately. See the *INDIAN MOTORCYCLE Service Manual* or an authorized INDIAN MOTORCYCLE dealer or other qualified dealer.

TIRE TREAD DEPTH

Replace any tire with a tread depth of less than 1/16 in (1.6 mm).

Tread wear indicators are located in at least three places on the tread circumference and become visible at a tread depth of approximately 1/16 in (1.6 mm). The tread wear indicators appear as a solid band across the tread.

You may also use a depth gauge or an accurate ruler to measure the depth of the center tire tread on both front and rear tires.

TIRE PRESSURE

Always check and adjust tire pressure when tires are cold. Do not adjust tire pressure immediately after riding. Wait at least 3 hours after riding to check pressure. If pressure checked and adjusted while tires are warm, the pressure will drop as tires cool and result in under inflation.

WARNING

Do not exceed the maximum recommended inflation pressure to seat the bead. Tire or rim failure may result causing serious injury or death.

| MODEL | LOCATION | BRAND/TYPE/SIZE | RECOM-MENDED PRESSURE |
|--------------|----------|--|-----------------------|
| FTR Rally | Front | Pirelli® Scorpion® Rally STR 120/70 R19 60V | 36 psi (248 kPa) |
| | Rear | Pirelli® Scorpion® Rally STR 150/70 R18 69V | 40 psi (276 kPa) |
| FTR FTR S | Front | Metzeler® Sportec® M9 RR 120/70 ZR17 58W | 36 psi (248 kPa) |
| | Rear | Metzeler® Sportec® M9 RR 180/55 ZR17 73W | 40 psi (276 kPa) |
| FTR R Carbon | Front | Metzeler® Sportec® M9 RR 120/70 ZR17 58W | 36 psi (248 kPa) |
| | Rear | Metzeler® Sportec® M9 RR 180/55 ZR17 73W | 40 psi (276 kPa) |

SEAT REMOVAL

1. Remove both Passenger Grab Handle Fasteners ① and Grab Handles ②.

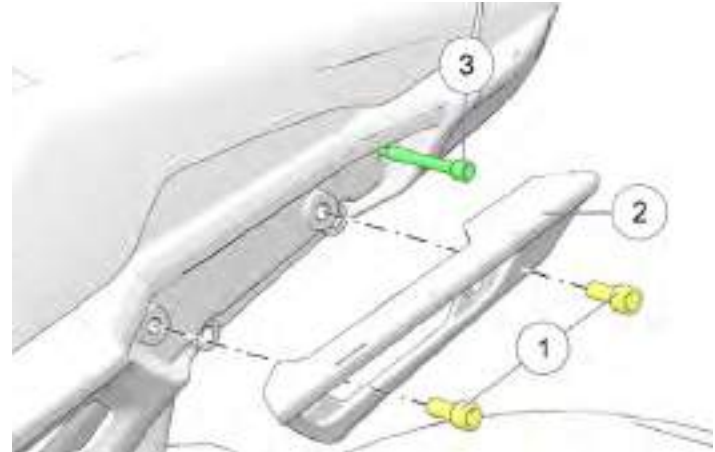

2. Remove Seat Fasteners ③.
3. Lift up on the rear of the seat and pull rearward to disengage the front of the seat from frame.

SEAT INSTALLATION

1. Identify two tabs located on the underside of the seat.

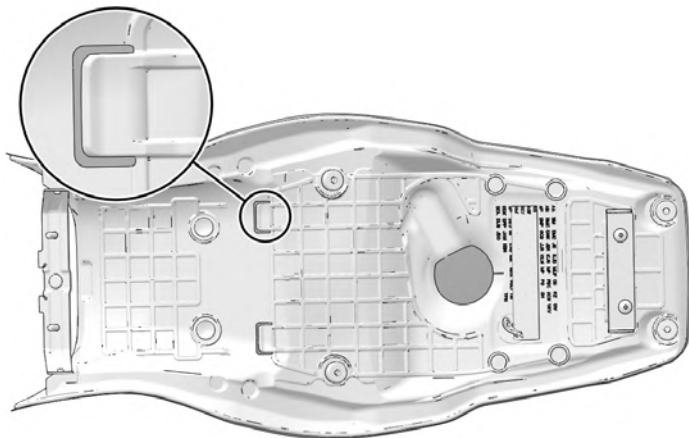

2. Slide the tabs shown above beneath the support bracket and into the front mounting bracket.

TIP

Pull up on the rear of the seat prior to installing fasteners to assure front tab engagement.

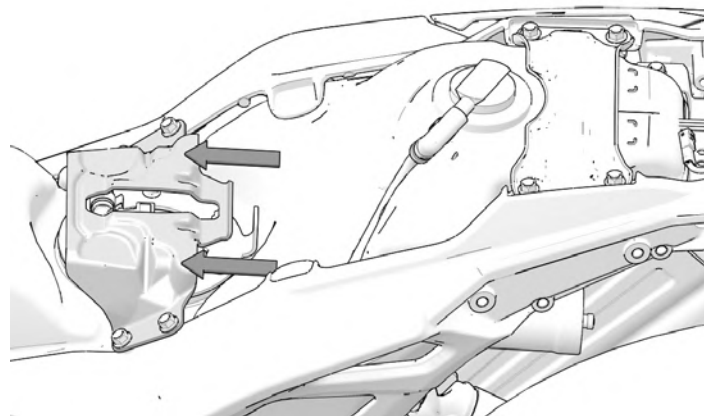

3. Secure the rear of the seat with the two fastener screws.

TORQUE

Seat Fasteners:
84 in-lbs (9.5 N·m)

4. Reinstall the two passenger grab handles with two screws per handle.

TORQUE

Passenger Grab Handle Fasteners:
19 ft-lbs (26 N·m)

SPARK PLUGS

See your dealer for spark plug inspections and replacement at the intervals specified in the Periodic Maintenance Table.

| SPARK PLUG SPECIFICATIONS | |
|---------------------------|---------------------|
| Spark Plug Type | NGK® MR7F |
| Spark Plug Gap | .030 in (0.80 mm) |
| Spark Plug Torque | 7.5 ft-lbs (10 N·m) |

HEADLIGHT AIM INSPECTION

On LOW beam, the top of the horizontal cut-off of the light beam ① should be 7 in (17.8 cm) lower than the center of the headlight bulb and centered straight ahead at 32 ft 10 in (10 m).

1. Verify that tire pressure is at specification.
2. Verify that rear suspension ride height (preload) is at specification.
3. Position the motorcycle on a level surface with the headlight 32 ft 10 in (10 m) from a wall.
4. With the operator and passenger (if applicable) on board, bring the motorcycle to the fully upright position.
5. Start the engine and switch the headlight to low beam. Observe the headlight aim on the wall.
6. Make any necessary adjustments to headlight aim.

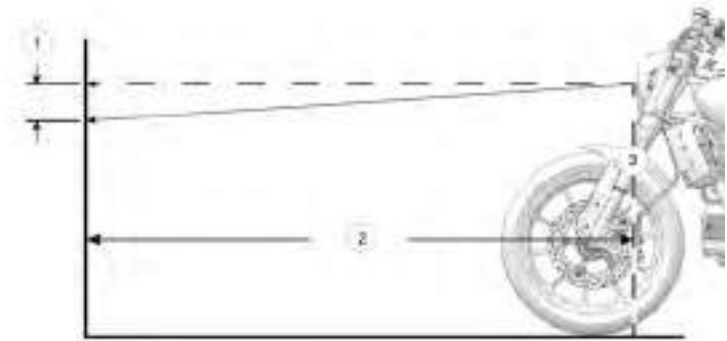

| NUMBER | DESCRIPTION |
|--------|---------------------------------------|
| ① | Measure distance = 4 in (10.2 cm) |
| ② | Measure distance = 32 ft 10 in (10 m) |
| ③ | Headlight Center |

HEADLIGHT AIM ADJUSTMENT

1. To adjust the headlamp vertically, loosen the two housing mount fasteners ① (one on each side) and pivot the housing upward or downward. Tighten the fasteners to specification.

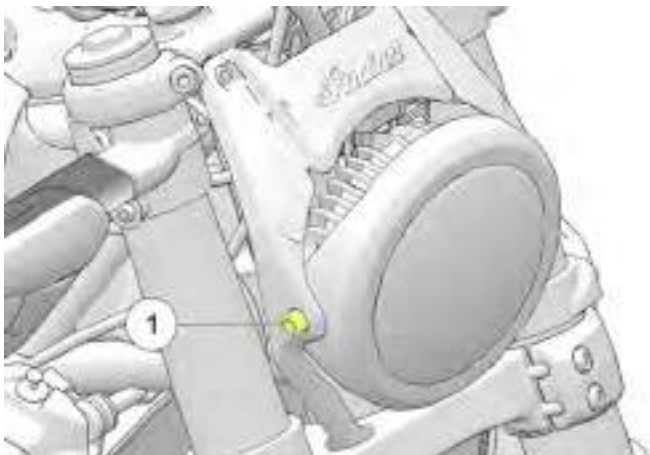

TORQUE

Headlight Adjustment Fastener:
25 ft-lbs (34 N·m)

HEADLIGHT COWL REMOVAL (IF APPLICABLE)

1. Remove and retain four screws ① and four washers ② from the headlight cowl.

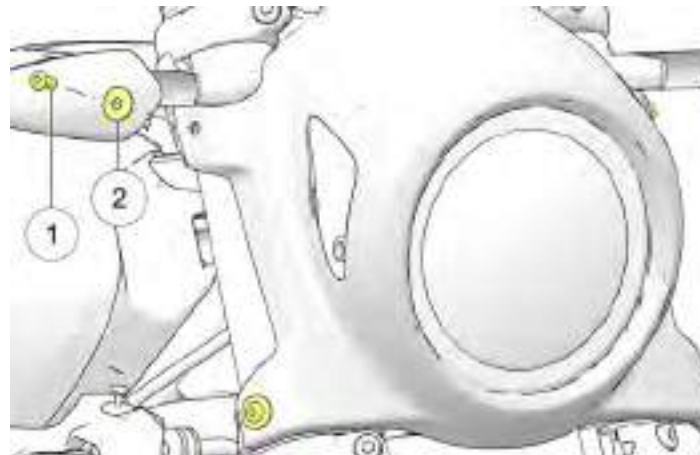

2. Remove headlight cowl and set aside for reinstallation.

HEADLIGHT REMOVAL

1. Remove and retain two screws ① from top of headlight bracket.

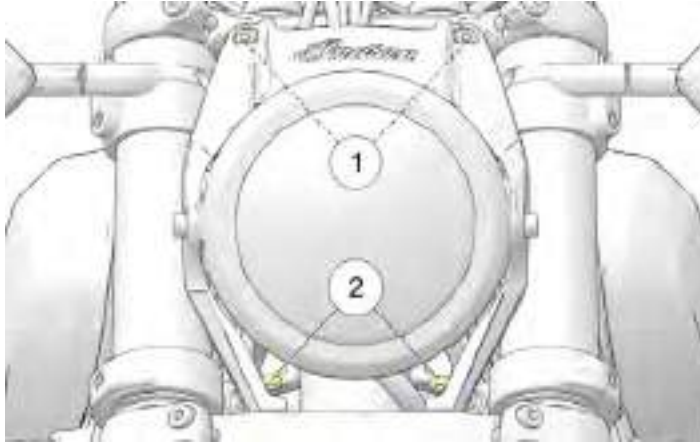

2. Remove and retain two nuts ② from bottom of headlight bracket.

TIP

Turn handlebars lock-to-lock to access two nuts from rear-side.

3. With headlight assembly unmounted, tilt assembly forward and slide electronic throttle control (ETC) connection off push-pin clip. It is not necessary to disconnect harnesses.

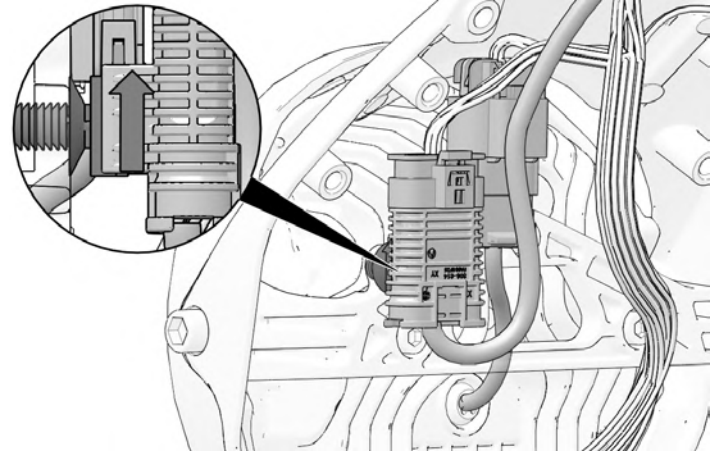

4. Disconnect headlight from chassis harness. Headlight connector will remain installed onto push-pin clip.
5. Carefully set headlight assembly aside on soft surface as to not scratch finished surfaces.

MAINTENANCE

BATTERY

The motorcycle battery is a sealed, maintenance-free battery. Do not remove the battery cap strip for any reason. Keep the battery connections clean and tight at all times.

WARNING

Battery electrolyte is poisonous. It contains sulfuric acid. Serious burns can result from contact with skin, eyes or clothing.

External: Flush with water.

Internal: Drink large quantities of water or milk. Follow with milk of magnesia, beaten egg, or vegetable oil. Call physician immediately.

Eyes: Flush with water for 15 minutes and get prompt medical attention.

Batteries may produce explosive gases.

- Keep sparks, flame, cigarettes, etc. away.
- Ventilate when charging or using in an enclosed space.
- Always shield eyes when working near batteries
- KEEP OUT OF REACH OF CHILDREN.

BATTERY REMOVAL

1. Remove the battery cover by removing three fasteners ①.

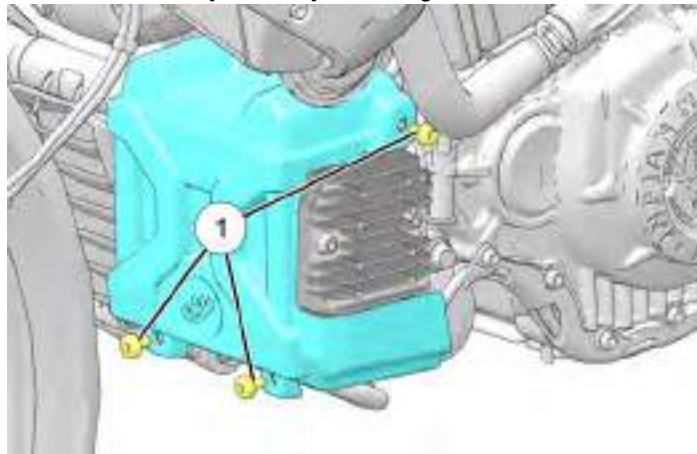

2. Disconnect negative battery terminal.

CAUTION

Be careful not to cross battery terminals.

3. Disconnect positive battery terminal.
4. Remove battery from battery box.

BATTERY INSTALLATION

1. Install battery into battery box.
2. Connect the positive battery terminal and torque fastener to specification.

TORQUE

Battery Terminal Fastener:
25 in-lbs (3 N·m)

3. Connect the negative battery terminal and torque fastener to specification.

TORQUE

Battery Terminal Fastener:
25 in-lbs (3 N·m)

4. Install battery cover and three fasteners.

TORQUE

Battery Cover Fastener
36 in-lbs (4 N·m)

BATTERY CHARGING AND MAINTENANCE

IMPORTANT

Read and follow the safety precautions listed on the battery and the proper battery charging procedures outlined in the Owner's Manual.

AGM BATTERY CHARGER RECOMMENDATIONS

INDIAN MOTORCYCLE recommends using the BatteryMINDer® 2012 AGM - 2 A battery charger (PN 2830438) to charge and maintain AGM batteries. The charger can be found on the Polaris PG&A website.

Batteries that fall below 12.5 V run the risk of sulfation, a condition whereby sulfate crystals form inside the battery and significantly reduce performance. AGM chargers are designed specifically for charging AGM type batteries and use high frequency pulses to partially reverse sulfation.

IMPORTANT

The use of non-AGM battery chargers may result in a misleading "battery not found" or "open cell" fault message. Please ensure you are using the recommended AGM charger when charging AGM type batteries.

AGM BATTERY CHARGING RECOMMENDATIONS – LOW CHARGE

The nominal voltage for an INDIAN MOTORCYCLE battery is 12.8 V when fully charged. The battery will self-discharge when disconnected from a vehicle, and will discharge at a faster rate when connected. If the battery voltage falls below 12.5 V, it should be charged immediately using the recommended battery charger.

Batteries which are not connected to a vehicle should be inspected every 2-3 months. The battery must be charged if found to be below 12.5 V.

Always use the recommended automatic battery charger, and wait for the charger to complete the charge cycle before disconnecting it.

AGM BATTERY CHARGING RECOMMENDATIONS – DEEPLY DISCHARGED (BELOW 3 VOLTS)

AGM batteries discharged to a voltage of 3 V or less may not be recognized by the recommended automatic battery charger. (The minimum voltage threshold recognized by other battery chargers may be as high as 10.5 V). Often times deeply discharged batteries can be restored by attaching another, fully-charged, battery to “jump start” the low battery. Follow the steps below to restore a deeply discharged battery.

1. Carefully connect the two batteries' positive terminals, then the negative terminals using jumper cables.
2. Connect the recommended battery charger to the low battery and initiate the charging sequence.



Always check to ensure the positive cables are connected to the positive terminals before powering the charger on. Reversing polarity when charging can damage electrical components and risk serious injury. Be careful not to let battery cable clamps touch each other.

3. After the charging sequence has initiated, disconnect the fully-charged battery. Always disconnect the fully-charged battery positive first, followed by low battery positive, low battery negative, and finally fully-charged battery negative
4. Proceed with charging both batteries to full capacity. Listed in the table below are the approximate charging times for deeply discharged batteries. Always use the recommended automatic battery charger, and wait for the charger to complete the charge cycle before disconnecting it. The recommended automatic charger will indicate when the battery is fully charged on its display.

AGM BATTERY CHARGING RECOMMENDATIONS TABLE

| STATE OF CHARGE | VOLTAGE (DC) | ACTION | RECOMMENDED CHARGE TIME* |
|--------------------------------|----------------|--|--------------------------|
| 100% | 12.8-13.2 V | None | None Required |
| 75%-100% | 12.6-12.8 V | May need slight charge If no charge given, check again within 4 weeks | 2-4 Hours |
| 50%-75% | 12.3-12.6 V | Needs Charge | 4-6 Hours |
| 25%-50% | 12.0-12.3 V | Needs Charge | 6-8 Hours |
| 0%-25% | 12.0 V or less | Needs Charge | At Least 8 Hours |
| *Assuming 2 A constant current | | | |

AGM BATTERY MAINTENANCE TIPS

1. If the motorcycle will not be driven for more than 2 weeks, maintaining the battery with the BatteryMINDER® 2012-AGM charger (PN 2830438) is recommended.
2. To help prolong battery life, it is recommended to remove the battery from vehicles stored ONE month or longer. To maximize the life of stored batteries, they should be kept in a cool / dry location. Batteries will self discharge more rapidly when stored in extreme temperatures. Batteries should be maintained using the recommended battery charger while in storage.
3. Batteries will self-discharge more quickly when dirty. Periodic cleaning of the battery terminals using a terminal brush will help maximize battery life. Wash terminals with a solution of one tablespoon baking soda and one cup water. Rinse well with tap water and dry off with clean shop towels. Coat the terminals with dielectric grease or petroleum jelly.

MAINTENANCE

4. Battery connections should be tightened to the correct torque during installation. This will reduce voltage drop and ensure a reliable connection between the regulator/rectifier and battery.
5. Your motorcycle is conveniently equipped with a SAE bullet style connector for quick access to charging the battery. The connector is located behind the left-hand side V cover and taped to the chassis harness.

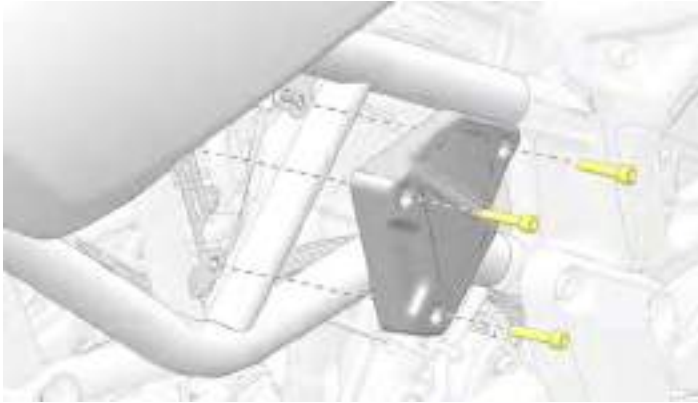

Carefully remove the tape to expose the connector and length of wire. Be sure to properly secure the wire and connector

before operating the vehicle.

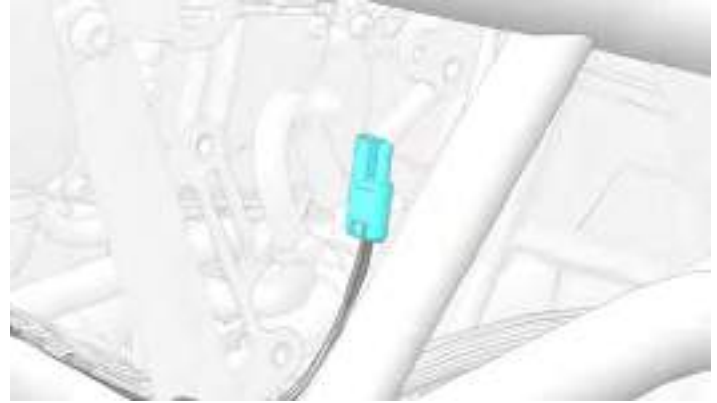

FUSE REPLACEMENT

The fuse panel is located on the right side of the unit.

1. Remove three fasteners ① and v-cover ② on the right side of the unit to access the fuse panel.

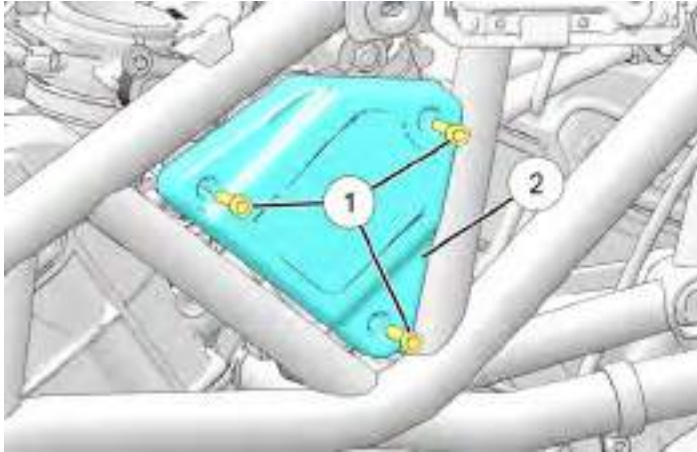

2. Remove the fuse box cover.

3. If any fuse is blown, turn off main switch. Install new fuse of specified amperage. Turn on switches and see if system operates correctly. Repeat fuse failure indicates an electrical problem.

⚠ CAUTION

Do not use fuses of a higher amperage rating than what is specified.

If the correctly rated fuse continues to blow, something is wrong and needs to be corrected. Substituting a higher amperage fuse can lead to extensive electrical system and vehicle damage.

4. Upon reassembly, torque cover fasteners to specification.

TORQUE

V-Cover Fastener:
36 in-lbs (4 N·m)

ELECTRICAL PRECAUTIONS

Be aware of the following precautions regarding the electrical system to avoid disruption of electrical signals and possible system malfunction.

- DO use ONLY genuine INDIAN MOTORCYCLE parts and accessories designed for your model, and follow the instructions provided.
- DO use the accessory power jack provided (if equipped).

MAINTENANCE

- DO NOT splice or cut any wires.
- DO NOT tap in to any power or ground on the motorcycle unless specifically directed to do so by the INDIAN MOTORCYCLE instructions that come with the kit.
- DO NOT back-probe electrical connectors on the vehicle unless directed to do so by the *INDIAN MOTORCYCLE Service Manual*.
- DO NOT power any accessories from the diagnostic connector.

EXHAUST SYSTEM INSPECTION

Check the exhaust system for stains from leaking exhaust gasses. Replace damaged or leaking exhaust gaskets. Check all exhaust system fasteners. Tighten loose clamps and fasteners. Do not overtighten. See the *INDIAN MOTORCYCLE Service Manual* or an authorized INDIAN MOTORCYCLE dealer or other qualified dealer.

NOTICE

Gasket is not reusable. Whenever a joint is taken apart, the gasket must be replaced.

ELEVATING THE MOTORCYCLE

WARNING

Serious injury or death can occur if the motorcycle tips or falls. Make sure the motorcycle will not tip or fall while elevated or while on the sidestand.

Some procedures require raising the motorcycle to remove weight from the component being inspected. Elevate the motorcycle by placing a stable, flat platform jack or lift mechanism on a firm, flat surface and lifting under the engine crankcase. The platform should be a minimum of 12 in (30 cm) square. DO NOT attempt to lift the motorcycle without proper equipment. Always secure the motorcycle properly before lifting so it cannot tip or fall when elevated.

FASTENER INSPECTION

1. Inspect the entire motorcycle chassis and engine for loose, damaged or missing fasteners. Tighten loose fasteners to the proper torque. See the *INDIAN MOTORCYCLE Service Manual* or an authorized INDIAN MOTORCYCLE dealer or other qualified dealer.
2. Always replace stripped, damaged or broken fasteners before riding. Use genuine INDIAN MOTORCYCLE fasteners of equal size and strength.

FASTENER TORQUES

Some procedures and fastener torques are not listed in this manual. See the *INDIAN MOTORCYCLE Service Manual* or an authorized INDIAN MOTORCYCLE dealer or other qualified dealer.

TROUBLESHOOTING

TROUBLESHOOTING

For your personal safety, do not attempt inspection or repairs not fully described in this rider's manual. Contact an authorized dealer for service if you cannot determine the cause of a problem or if the inspection/repair exceeds your mechanical ability or tool resources. Do not perform any inspection or repair with the engine running.

ENGINE CRANKS BUT WILL NOT START

| POSSIBLE CAUSE | POSSIBLE REMEDY/ACTION |
|--|---|
| Low fuel | Verify fuel level |
| Fuel pump doesn't operate | Turn engine STOP switch to RUN. Turn the ignition key on. The fuel pump should run momentarily and then stop. Check the fuel pump/ignition circuit breaker. See page 141. |
| Battery voltage is too low | Fully charge the battery. See page 137. |
| Fouled spark plug(s) | Please see your dealer. |
| Low compression | Please see your dealer for an engine compression test. |
| The IGN COIL fuse has become damaged or opened | Check fuse box to verify IGN COIL fuse is intact. See page 141. |

STARTER MOTOR CLICKS, DOES NOT TURN OR TURNS SLOWLY

| POSSIBLE CAUSE | POSSIBLE REMEDY/ACTION |
|--|---|
| Engine stop/run switch is in stop position | Place switch in RUN position. |
| Discharged battery | Fully charge the battery. See page 137. |
| Loose or corroded battery cables | Inspect battery cables. |
| Transmission is in gear | Shift transmission into neutral or pull the clutch lever in to disengage the clutch. See page 68. |

TROUBLESHOOTING

ENGINE STARTS BUT MISSES OR RUNS POORLY

TIP

Turn engine OFF before inspecting any of these items.

| POSSIBLE CAUSE | POSSIBLE REMEDY/ACTION |
|--|--|
| Discharged battery | Fully charge the battery. |
| Loose or corroded battery cables | Inspect battery cables and connections. |
| Fouled spark plug(s) | Please see your dealer. |
| Contaminated fuel | Inspect fuel for water/contamination. Please see your dealer. |
| Engine oil level incorrect or wrong oil type | Inspect level and quality of oil. |
| Loose, broken, shorted ignition coil wires | Inspect coil primary wires. Please see your dealer. |
| Air intake restricted | Inspect air filter. |
| Intake leaks | Inspect air box, crankcase breather hoses, throttle body and intake boot joints. |
| IGN COIL fuse has become damaged or opened | Check fuse box to verify IGN COIL fuse is intact. |

SHIFTING DIFFICULTIES OR HARD TO FIND NEUTRAL

| POSSIBLE CAUSE | POSSIBLE REMEDY/ACTION |
|--|---|
| Clutch damage | Replace clutch. |
| Clutch cable not adjusted properly | Please see your dealer for inspection and adjustment. |
| Shift linkage not adjusted properly | Please see your dealer for inspection and adjustment. |
| Incorrect oil or oil in poor condition | Replace the oil with the recommended oil. |

ENGINE OVERHEATING

| POSSIBLE CAUSE | POSSIBLE REMEDY/ACTION |
|----------------------------------|--|
| Debris lodged in radiator screen | Inspect and clean the screen. |
| Plugged radiator | Use a garden hose to flush any debris from the radiator fins. DO NOT use a high pressure washer, which can damage the radiator fins. |
| Blocked fan | Inspect fan, remove any blockage. |
| Fan doesn't operate | Please see your dealer. |
| Low coolant | Allow the engine to cool before checking coolant level. See page 101. |
| Air in cooling system | Please see your dealer. |

BATTERY CHARGING RATE LOW OR BATTERY DISCHARGES

| POSSIBLE CAUSE | POSSIBLE REMEDY/ACTION |
|--|--|
| Loose/Corroded Charging Circuit Connection | Check/clean battery cable connections. Check/clean charging circuit connections. Please see your dealer. |
| Accessory Load Exceeds Charge Rate | Limit accessory operation when the engine is off. |
| Improperly Wired Accessory (Current Draw) | Please see your dealer to check charging system output and current draw. |

BRAKE NOISE/POOR BRAKE PERFORMANCE**NOTICE**

See your dealer if brake performance does not return after these inspections.

TROUBLESHOOTING

| POSSIBLE CAUSE | POSSIBLE REMEDY/ACTION |
|---|---|
| Dust/Dirt On Brake Disc(s) | Clean disc. See the Brake Disc Inspection / Cleaning section. |
| Worn Pads Or Disc/Brake Disc Damage | Inspect pads. See the Brake Disc Inspection / Cleaning section. |
| Brake Fluid Level Low Or Fluid Contaminated | Inspect fluid level/fluid condition. See the Front Brake Fluid Level and Rear Brake Fluid Level sections. |

ANTI-LOCK BRAKE LIGHT REMAINS ILLUMINATED OR ILLUMINATES INTERMITTENTLY

| POSSIBLE CAUSE | POSSIBLE REMEDY/ACTION |
|-----------------------------|--|
| Blown fuse | Check the fuses. See page 141. |
| Loose or damaged tone ring | Inspect tone ring for looseness or chipped teeth. |
| Debris lodged in components | Inspect wheel speed sensor and tone ring for debris. |
| Damage caused by debris | Inspect wheel speed sensor for cracked housing. |
| Damaged components | See service manual or authorized dealer. |

CLEANING AND STORAGE

CLEANING PRODUCTS

This section provides tips on the very best way to clean, polish and preserve every surface of your beautiful new INDIAN MOTORCYCLE. We recommend the use of our new INDIAN MOTORCYCLE cleaning and polishing products and accessories, which have been specially designed to offer the best care possible for your INDIAN MOTORCYCLE.

In addition to the products recommended in this section for cleaning and polishing, INDIAN MOTORCYCLE also has specialty products for:

- enhancing black and silver engines
- cleaning engines, tires and wheels
- removing brake dust

After cleaning the motorcycle, inspect for damage to the painted surfaces. Chips or scratches should be repaired promptly to prevent corrosion.

For Matte Clear Coat Finish Care, see the *Matte Clear Coat Finish Care* section for details.

For Gloss Clear Coat Finish Care, see the *Gloss Clear Coat Finish Care* section for details.

For more information, or for answers to your cleaning and detailing questions, please see your INDIAN MOTORCYCLE dealer.

WASHING THE MOTORCYCLE

NOTICE

Do not use pressurized water to wash the motorcycle. Water may seep in and deteriorate wheel bearings, brake caliper assemblies, brake master cylinders, electrical connectors, steering head bearings, and transmission seals. Do not direct any water stream at air intakes, exhaust outlets, electrical connectors or audio system speakers. Electrical components may be damaged by water. Do not allow water to contact electrical components or connectors

1. Before washing, make sure exhaust pipes are cool. Cover each pipe opening with a plastic bag secured with a strong rubber band. Check that the spark plugs, spark plug wire caps, oil fill cap and fuel caps are properly seated.
2. Do not use abrasive cleaners.
3. Rinse off as much dirt and mud as possible with water running at low pressure. Use as little water as possible when washing near the air intake or the exhaust pipe openings. Dry these components thoroughly before using the motorcycle.
4. Clean the front fork tubes thoroughly to reduce fork seal wear and leakage.

CLEANING AND STORAGE

5. After washing, remove the rubber bands and plastic bags from the exhaust pipes. Start the engine and let it idle for a few minutes.
6. Make sure the brakes are functioning properly before riding.

WINDSHIELD CARE (IF EQUIPPED)

Clean the windshield with a soft cloth and plenty of warm water. Dry with a soft clean cloth. Remove minor scratches with a high-quality polishing compound designed for use on polycarbonate surfaces.

NOTICE

Brake fluid and alcohol will permanently damage the windshield and some types of thread-locking agents. Do not use glass cleaners, water or soil repellents, and petroleum or alcohol based cleaners on the windshield, as these products can damage the windshield.

GLOSS CLEAR COAT FINISH CARE

The Axalta® Sports and Equipment Finish System™ was used to provide the original gloss finish on your motorcycle. This finish system provides superior protection against the elements. To maximize the benefits of this system, use the following guide to care for the gloss finish on your motorcycle.

- During the first 30 days, when the finish is still fresh, clean the motorcycle with a water rinse only.
- Do not wax the motorcycle for the first 60 days. Doing so can cause loss of the gloss. After 60 days, use only waxes designed for new clear coat finishes.
- Do not use pressurized water to wash the motorcycle. When paint is still fresh, pressurized water could damage the finish. If using a pressure washer is unavoidable, keep the spray nozzle at least 24 in (60 cm) away from the surface of the motorcycle.
- Wash your motorcycle often, especially when exposed to salty, dusty, acidic or alkaline environments.
- Use warm or cool water and a soft cloth for cleaning.
- Use soaps that are non-abrasive and have a neutral pH (non acidic/non alkaline detergents).
- Do not use solvent-based solutions.
- Do not use a dry cloth to remove dust.
- Do not use a stiff bristle brush, which can scratch the surface.
- Do not wash with extremely hot water.
- Do not wash the motorcycle while the surface is hot and avoid washing the motorcycle in the hot sun. Minerals in the water may be difficult to remove once dried on the surface of the motorcycle.
- Do not allow spilled gasoline, motor oil or brake fluid to stand on the paint. Remove these substances immediately by rinsing with water. Use a soft cloth to absorb any remaining residue and dab dry.

- To remove bug remnants or road tar, use only products that are specifically designed for this purpose. Follow the product manufacturer's recommendations to prevent potential damage to the finish. Follow with a wash using the methods described in this section.
- Always brush away any ice or snow, do not scrape off.
- Chips or scratches should be repaired promptly to prevent corrosion.

MATTE CLEAR COAT FINISH CARE

Matte finish products are prone to trapping dirt, oils and other contaminants. Always clean this type of finish with warm water and a mild dish-washing detergent. Use a soft sponge to gently rub the surface, then rinse with clean warm water. For stubborn stains such as grease or oil, use a citrus-based cleaner. Spray the cleaner onto the area and rub gently with a soft sponge. Allow the cleaner to sit for a couple of minutes, then rinse well with clean warm water. Repeat as needed.

NOTICE

Never use a polishing/buffing wax or any sponge that has an abrasive surface when cleaning a matte finish. These products will buff the matte surface of the finish and result in a glossy finish. Never clean matte finishes with a pressure washer, as this will further imbed contaminants into the clear coat and may damage labels and decals.

STORAGE AREA PREPARATION

Choose a dry, well-ventilated storage location, inside a garage or other structure if possible. The location should have a firm, flat surface and allow enough space for the motorcycle.

WARNING

Gasoline is highly flammable and explosive under certain conditions. Do not store the motorcycle in any area (in home or garage) where it could be near open flames, pilot lights, sparks or electric motors. Do not smoke in the storage area.

To best preserve tire condition:

- The storage area should have a relatively constant and moderate temperature.
- The storage surface should be free of oil and gasoline.
- The motorcycle should not be near a radiator or other heat source, or any type of electric motor.

FUEL STABILIZER

Add fresh fuel to fill the fuel tank and add fuel stabilizer. Do not overfill.

Ride the motorcycle or start and run the engine for 15 minutes in a well ventilated area to distribute the stabilizer throughout the fuel system.

CLEANING AND STORAGE

TIRE INFLATION

Inflate the tires to normal pressure. See the Tire Pressure section for details.

ENGINE PROTECTION

Change the engine oil. See the Engine Oil / Filter Change section for details.

COOLING SYSTEM

Check the coolant level and maintain as recommended by adding coolant to the recovery bottle. See the *Coolant Level Inspection* section for details.

MAINTENANCE DURING STORAGE

During extended storage periods, maintain tire pressure and battery voltage at the recommended levels.

RODENTS

Mice and other rodents are often the worst enemy of a stored motorcycle. If the motorcycle will be stored in an area where mice are a concern (particularly in rural areas, barns, sheds, etc.) be sure to take extra measures to deter their infestation. This may include placing a screen mesh over any intake or exhaust openings (just be sure to remember to remove them when you take the motorcycle from storage).

PARK AND COVER THE MOTORCYCLE

1. Park the motorcycle in its storage location. Block the frame to take some of the weight off the front and rear wheels.

NOTICE

Starting the motorcycle periodically during storage is NOT recommended. Water vapor is a by-product of the combustion process, and corrosion may result unless the engine is operated long enough to bring the oil and exhaust system to normal operating temperature.

2. Secure a plastic bag over the (cooled) exhaust outlets to prevent moisture from entering the exhaust system.
3. Cover the motorcycle with a cover made from a durable, breathable material designed for storage. Covering the motorcycle helps protect it from dust and other airborne materials. The cover must be of a breathable material to prevent moisture from building up on the motorcycle which can cause oxidation of metal surfaces.

REMOVAL FROM STORAGE

1. Install a fully charged battery.
2. Check the oil level. If the motorcycle was stored in an area subject to wide swings in temperature and humidity (such as outdoors), change the engine oil before starting the engine.

| <i>NOTICE</i> |
|---|
| During storage, temperature and humidity changes can cause condensation to form in the crankcase and mix with engine oil. Running the engine with oil that contains condensation can cause engine damage. |

- | |
|---|
| During storage, temperature and humidity changes can cause condensation to form in the crankcase and mix with engine oil. Running the engine with oil that contains condensation can cause engine damage. |
|---|
3. Inspect the storage area for signs of fluid leaks. Identify and perform service to any leaking components.
 4. Remove any intake or exhaust mesh covers installed for rodent protection.
 5. Make sure the fuel tank is at least 3/4 full.
 6. Perform the pre-ride inspections. See page 53.
 7. Perform a road test. See page 78.
 8. Wash and polish the motorcycle. Wax, polish or apply protectant to appropriate components.

SPECIFICATIONS

FTR

| DIMENSIONS | | |
|---------------------|--------------------------------|-----------------------------------|
| | FTR Rally | FTR / FTR S / FTR R Carbon |
| Overall Length | 90 in (2287 mm) | 90 in (2287 mm) |
| Overall Width | 33.9 in (862 mm) | 32.5 in (825 mm) |
| Overall Height | 47.2 in (1200 mm) | 44.3 in (1126 mm) |
| Unladen Seat Height | 33.6 in (853 mm) | 32.4 in (824 mm) |
| Wheelbase | 60.0 in (1524 mm) | 60.0 in (1524 mm) |
| Ground Clearance | 7.2 in (183 mm) | 6.5 in (165 mm) |
| Rake (frame)/ Trail | 26.3 Degrees/5.1 in (130.0 mm) | 25.3 Degrees/3.9 in (99.9 mm) |

| WEIGHT | |
|---|-----------------|
| Dry Weight (without fuel/fluids) | |
| FTR | 482 lb (218 kg) |
| FTR S | 482 lb (218 kg) |
| FTR Rally | 497 lb (225 kg) |
| FTR R Carbon | 479 lb (217 kg) |
| Wet Weight (with fuel/fluids) | |
| FTR | 514 lb (233 kg) |

SPECIFICATIONS

| | |
|---|---|
| FTR S | 514 lb (233 kg) |
| FTR Rally | 529 lb (240 kg) |
| FTR R Carbon | 513 lb (232 kg) |
| Gross Vehicle Weight Rating (GVWR) | |
| All Models | 948 lb (430 kg) |
| Gross Axle Weight Rating (GAWR) | |
| All Models | Front: 375 lb (170 kg) Rear: 595 lb (270 kg) |
| Maximum Load Capacity (riders, cargo, accessories) | |
| FTR | 434 lb (197 kg) |
| FTR S | 434 lb (197 kg) |
| FTR Rally | 419 lb (190 kg) |
| FTR R Carbon | 435 lb (198 kg) |

| CAPACITIES | | | |
|---------------------------------|--|--|--|
| | FTR Rally | FTR / FTR S | FTR R Carbon |
| Radiator Coolant | 2.32 qt (2.2 L) | | |
| Engine Oil | 4.4 qt (4.16 L) Dry Engine | | |
| Fuel | 3.4 gal (13.0 L) | | |
| Fuel Reserve (fuel light on) | 0.5 gal (1.9 L) | | |
| Fork Oil | Non-Adjustable: 17.5 ± 0.2 fl oz 518 ± 6 cm ³ | Adjustable: 14.5 ± 0.2 fl oz 429 ± 6 cm ³ | Adjustable: 18.4 ± 0.2 fl oz 544 ± 6 cm ³ |

SPECIFICATIONS

| WHEELS / TIRES | | |
|---------------------------|---|---|
| | FTR Rally | FTR / FTR S / FTR R Carbon |
| Front Wheel Size/ Type | 19 in (48.26 cm) x 3.00 in (7.62 cm) Cast | 17 in (43.18 cm) x 3.50 in (8.89 cm) Cast |
| Rear Wheel Size/ Type | 18 in (45.72 cm) x 4.25 in (10.80 cm) Cast | 17 in (43.18 cm) x 5.5 in (13.97 cm) Cast |
| Front Tire Type/ Size | 120/70 R19 60V | 120/70 ZR17 58W |
| Rear Tire Type/ Size | 150/70 R18 69V | 180/55 ZR17 73W |
| Tire Pressure | Front: 36 psi (248 kPa) Rear: 40 psi (276 kPa) | |

| CHASSIS | | |
|-----------------------------|--|--|
| | FTR Rally | FTR / FTR S / FTR R Carbon |
| F Suspension Type/Travel | Inverted Telescopic Cartridge Fork / 150 mm | Adjustable Inverted Telescopic Cartridge Fork / 120 mm |
| F Fork Tube Diameter | 43 mm | 43 mm |
| R Suspension Type/Travel | Monotube IFP / 150 mm | Piggyback IFP / 130 mm |
| Swingarm | Steel | |
| Front Brakes | Dual / 320 mm x t5 Rotor / 4-Piston Caliper | |
| Rear Brakes | Single/ 260 mm x t5 Rotor / 2-Piston Caliper | |

SPECIFICATIONS

| ENGINE | |
|---------------------------------------|---|
| Engine Type | Liquid Cooled V-Twin (60 Degrees) |
| Displacement | 73 Cid (1203 cc) |
| Compression Ratio | 12.5 : 1 |
| Valve Train | DOHC, 4 Valves Per Cylinder, Graded Buckets |
| Bore and Stroke | 102 mm x 73.6 mm |
| Fuel System/ Throttle Body Bore | Closed Loop Fuel Injection / Dual 60 mm Bore |
| Exhaust System | Two O2 Sensors (one in each bank) Single three-way catalyst in resonator |
| Rev Limit | 9000 RPM |
| Idle RPM | 1250 RPM +/- 50 RMP (Fully Warm) |
| Lubrication System | Semi-Dry Sump |
| Spark Plug/Gap | NGK® MR7F 0.030 in (0.80 mm) |

| DRIVETRAIN | | |
|-------------------|---------------------------------|--|
| | FTR RALLY | FTR / FTR S / FTR R CARBON / CHINESE MODELS |
| Primary Drive | Gear Drive Wet Clutch | |
| Crank Gear | 46-Tooth | |
| Clutch Gear | 77-Tooth | |
| Clutch Type | Wet, Assist & Slip, Multi-Plate | |

| DRIVETRAIN | | |
|-------------------------|--------------------------------------|--|
| | FTR RALLY | FTR / FTR S / FTR R CARBON / CHINESE MODELS |
| Primary Reduction Ratio | 1.674 : 1 | |
| Transmission Type | 6 Speed / Constant-Mesh / Foot Shift | |
| Gear Shift Pattern | 1 Down / 5 Up | |
| Final Drive Type | Chain / 525HV3X / 116 Link | Chain / 525HV3X / 114 Link |

| ELECTRICAL | |
|-------------------|---|
| Alternator | 460W @ 3000 RPM |
| Battery | 12 V, 12AH, 240 CCA Maintenance Free AGM |
| Voltage Regulator | 14.5 V / 32 A |
| Headlight | Non-Serviceable LED |
| Tail/Brake Light | Non-Serviceable LED |
| Turn Signal | Non-Serviceable LED |
| License Plate | Non-Serviceable LED |
| Speedometer | Non-Serviceable LED |
| Indicator Lights | Non-Serviceable LED |
| Position Bulb | Non-Serviceable LED |

SPECIFICATIONS

FUEL RECOMMENDATION

For best performance, use only unleaded gasoline with a 91 pump octane minimum (R+M/2 Method) or 95 RON minimum. **DO NOT USE E-85 GASOLINE OR GASOLINE CONTAINING METHANOL.** Using E85 or gasoline/methanol blends can result in poor starting and driveability, engine damage and damage to critical fuel system components.

- *Gasoline containing up to 10% Ethanol can be used.*

In the event that the recommended premium unleaded gasoline is not available and low octane fuel must be used, fill the fuel tank only partially with unleaded regular gasoline, then fill the tank fully with premium unleaded gasoline as soon as possible.



ENGINE OIL RECOMMENDATION

We recommend the use of INDIAN MOTORCYCLE Full Synthetic 15W-60 Engine Oil for your motorcycle. This oil is formulated with synthetic-based oil and premium engine additive which have physical properties that meet API SM and ILSAC GF-4 specifications.

Do not blend oil additives with engine oil.

If oil must be added in an emergency and the recommended oil is not available, choose only a high-quality 15W-60 motorcycle oil. Change back to the recommended oil at the first opportunity.

Engine oil for this vehicle needs to be JASO MA compliant.

NOTICE

Use of non-recommended lubricants can result in engine damage. Damage resulting from the use of non-recommended lubricants is not covered by warranty.

FORK OIL

We recommend the use of INDIAN MOTORCYCLE Fork Oil for your motorcycle.

BRAKE FLUID

We recommend the use of INDIAN MOTORCYCLE DOT 4 Brake Fluid for both brake master cylinders. *DO NOT use DOT 5 silicone fluid.*

WARRANTY

INDIAN MOTORCYCLE WARRANTY POLICY

LIMITED WARRANTY

INDIAN MOTORCYCLE, 2100 Highway 55, Medina, MN 55340 (INDIAN MOTORCYCLE) gives a TWO YEAR LIMITED WARRANTY on all components of your INDIAN MOTORCYCLE against defects in material or workmanship. This warranty covers parts and labor charges for repair or replacement of defective parts and begins on the date of purchase by the original retail purchaser. This warranty is transferable to another owner during the warranty period through an INDIAN MOTORCYCLE dealer, but any such transfer will not extend the original term of the warranty. The duration of this warranty may vary by international region based upon local laws and regulations.

REGISTRATION

At the time of sale, the Warranty Registration Form must be completed by your dealer and submitted to INDIAN MOTORCYCLE within ten days of purchase. Upon receipt of this registration, INDIAN MOTORCYCLE will record the registration for warranty. No verification of registration will be sent to the purchaser as the copy of the Warranty Registration Form will be your proof of warranty coverage. If you have not signed the original registration and received the customer copy, please contact your dealer immediately. **NO WARRANTY COVERAGE WILL BE ALLOWED UNLESS YOUR MOTORCYCLE IS REGISTERED WITH INDIAN MOTORCYCLE.** Initial dealer preparation and set-up of your motorcycle is very important in ensuring trouble-free operation. Purchasing a vehicle in the crate or without proper dealer set-up will void your warranty coverage.

WARRANTY

LIMITATIONS OF WARRANTIES AND REMEDIES

This INDIAN MOTORCYCLE limited warranty excludes any failures that are not caused by a defect in material or workmanship. THIS WARRANTY DOES NOT COVER CLAIMS OF DEFECTIVE DESIGN. This warranty also does not cover acts of God, accidental damage, normal wear and tear, abuse or improper handling. This warranty also does not cover any motorcycle, component, or part that has been altered structurally, modified, neglected, improperly maintained or used for racing, competition, or purposes other than for which it was designed.

This warranty excludes damages or failures resulting from: improper lubrication; improper engine timing; improper fuel; surface imperfections caused by external stress, heat, cold or contamination; operator error or abuse; improper component alignment, tension, adjustment or altitude compensation; snow, water, dirt or other foreign substance ingestion/contamination; improper maintenance; modified components; use of aftermarket or unapproved components, accessories, or attachments; unauthorized repairs; or repairs made after the warranty period expires or by an unauthorized repair center.

This warranty excludes damages or failures caused by abuse, accident, fire, or any other cause other than a defect in materials or workmanship and provides no coverage for consumable components, general wear items, or any parts exposed to friction surfaces, stresses, environmental conditions and/or contamination for which they were not designed or not intended, including but not limited to the following items:

- Wheels and tires
- Suspension components
- Brake components
- Seat components
- Clutches and components
- Steering components
- Batteries
- Light bulbs/Sealed beam lamps
- Filters
- Lubricants
- Bushings
- Sealants
- Coolants
- Bearings
- Finished and unfinished surfaces
- Fuel Injectors/Throttle body components
- Engine components
- Drive chain
- Hydraulic components and fluids
- Circuit breakers/Fuses
- Electronic components
- Spark plugs

LUBRICANTS AND FLUIDS

1. Mixing oil brands or using non-recommended oil may cause engine damage. We recommend the use of INDIAN MOTORCYCLE engine oil.
2. Damage or failure resulting from the use of non-recommended lubricants or fluids is not covered by this warranty.

This warranty provides no coverage for personal loss or expense, including mileage, transportation costs, hotels, meals, shipping or handling fees, motorcycle pick-up or delivery, replacement rentals, loss of vehicle use, loss of profits, or loss of vacation or personal time.

The exclusive remedy for breach of this warranty shall be, at INDIAN MOTORCYCLE's option, repair or replacement of any defective materials, components, or products. THE REMEDIES SET FORTH IN THIS WARRANTY ARE THE ONLY REMEDIES AVAILABLE TO ANY PERSON FOR BREACH OF THIS WARRANTY. INDIAN MOTORCYCLE SHALL HAVE NO LIABILITY TO ANY PERSON FOR INCIDENTAL, CONSEQUENTIAL OR SPECIAL DAMAGES OF ANY DESCRIPTION, WHETHER ARISING OUT OF EXPRESS OR IMPLIED WARRANTY OR ANY OTHER CONTRACT, NEGLIGENCE, OR OTHER TORT OR OTHERWISE. THIS EXCLUSION OF CONSEQUENTIAL, INCIDENTAL, AND SPECIAL DAMAGES IS INDEPENDENT FROM AND SHALL SURVIVE ANY FINDING THAT THE EXCLUSIVE REMEDY FAILED OF ITS ESSENTIAL PURPOSE.

THE IMPLIED WARRANTY OF FITNESS FOR A PARTICULAR PURPOSE IS EXCLUDED FROM THIS LIMITED WARRANTY. ALL OTHER IMPLIED WARRANTIES (INCLUDING BUT NOT LIMITED TO THE IMPLIED WARRANTY OF MERCHANTABILITY) ARE LIMITED IN DURATION TO THE ABOVE TWO YEAR WARRANTY PERIOD. INDIAN MOTORCYCLE DISCLAIMS ALL EXPRESS WARRANTIES NOT STATED IN THIS WARRANTY. SOME STATES DO NOT PERMIT THE EXCLUSION OR LIMITATION OF INCIDENTAL OR CONSEQUENTIAL DAMAGES OR ALLOW LIMITATIONS ON THE DURATION OF IMPLIED WARRANTIES, SO THE ABOVE LIMITATIONS MAY NOT APPLY TO YOU IF INCONSISTENT WITH CONTROLLING STATE LAW.

HOW TO OBTAIN WARRANTY SERVICE

If your motorcycle requires warranty service, you must take it to an INDIAN MOTORCYCLE Servicing Dealer. When requesting warranty service you must present your copy of the Warranty Registration Form to the dealer. (THE COST OF TRANSPORTATION TO AND FROM THE DEALER IS YOUR RESPONSIBILITY). INDIAN MOTORCYCLE suggests that you use your original selling dealer; however, you may use any INDIAN MOTORCYCLE Servicing Dealer to perform warranty service.

WARRANTY

IN THE COUNTRY WHERE YOUR MOTORCYCLE WAS PURCHASED:

Warranty or Service Bulletin repairs must be done by an authorized INDIAN MOTORCYCLE dealer. If you move or are traveling within the country where your motorcycle was purchased, Warranty and Service Bulletin repairs may be requested from any authorized INDIAN MOTORCYCLE dealer.

OUTSIDE THE COUNTRY WHERE YOUR MOTORCYCLE WAS PURCHASED:

If you are traveling temporarily outside the country where your motorcycle was purchased, you should take your motorcycle to an authorized INDIAN MOTORCYCLE dealer. You must show the dealer photo identification from the country of the selling dealer's authorized location as proof of residence. Upon residence verification, the servicing dealer will be authorized to perform the warranty repair.

IF YOU MOVE:

If you move to another country, be sure to contact INDIAN MOTORCYCLE Customer Assistance and the customs department of the destination country before you move. Vehicle importation rules vary considerably from country to country. You may be required to present documentation of your move to INDIAN MOTORCYCLE in order to continue your warranty coverage. You may also be required to obtain documentation from INDIAN MOTORCYCLE in order to register your motorcycle in your new country. You should warranty register your motorcycle at a local INDIAN MOTORCYCLE dealer in your new country immediately after you move to continue your warranty coverage and to ensure that you receive information and notices regarding your motorcycle.

IF YOU PURCHASE FROM A PRIVATE PARTY:

If you purchase an INDIAN MOTORCYCLE from a private party, to be kept and used outside of the country in which the motorcycle was originally purchased, all warranty coverage will be denied. You must nonetheless register your motorcycle under your name and address with a local INDIAN MOTORCYCLE dealer in your country to ensure that you receive safety information and notices regarding your motorcycle.

EXPORTED VEHICLES

EXCEPT WHERE SPECIFICALLY REQUIRED BY LAW, THERE IS NO WARRANTY OR SERVICE BULLETIN COVERAGE ON THIS VEHICLE IF IT IS SOLD OUTSIDE THE COUNTRY OF THE SELLING DEALER'S AUTHORIZED LOCATION. This policy does not apply to vehicles that have received authorization for export from INDIAN MOTORCYCLE. Dealers may not give authorization for export. You should consult an authorized dealer to determine this vehicle's warranty or service coverage if you have any questions. This policy does not apply to vehicles registered to government officials or military personnel on assignment outside the country of the selling dealer's authorized location. This policy does not apply to Safety Bulletins.

NOTICE

If your vehicle is registered outside of the country where it was purchased and you have not followed the procedure set above, your vehicle will no longer be eligible for warranty or service bulletin coverage of any kind, other than safety bulletins. Vehicles registered to Government officials or military personnel on assignment outside of the country where the vehicle was purchased will continue to be covered by the Limited Warranty.

Please work with your dealer to resolve any warranty issues. Should your dealer require any additional assistance, they will contact the appropriate person at INDIAN MOTORCYCLE.

This warranty gives you specific legal rights, and you may also have other rights which vary from state to state or in different countries. If any of the above terms are void because of federal, state, local law, all other warranty terms will remain in effect.

For questions call INDIAN MOTORCYCLE Customer Assistance:

United States & Canada: 1-877-204-3697

French: 1-800-268-6334

WARRANTY

MOTORCYCLE NOISE REGULATION

Tampering with noise control systems is prohibited. Federal law prohibits the following acts or causing thereof:

- The removal or rendering inoperative by any person other than for the purposes of maintenance, repair, or replacement, of any device or element of design incorporated into any new vehicle for the purpose of noise control prior to its sale or delivery to the ultimate purchaser or while it is in use, or
- The use of the vehicle after such device or element of design has been removed or rendered inoperative by any person.

Among those acts presumed to constitute tampering are the acts listed below:

- Removal or puncturing of the muffler, baffles, header pipes, or any other component which conducts exhaust gasses.
- Removal or puncturing of any part of the intake system.
- Lack of proper maintenance.
- Replacing any moving part of the vehicle, or parts of the exhaust system or intake system, with parts other than those specified by the manufacturer.

This product should be checked for repair or replacement if the motorcycle noise has increased significantly through use. Otherwise, the owner may become subject to penalties under state and local ordinances.

NOISE EMISSION WARRANTY

INDIAN MOTORCYCLE warrants that this exhaust system, at the time of sale, meets all applicable U.S. EPA Federal noise standards. This warranty extends to the first person who buys this exhaust system for purposes other than resale, and to all subsequent buyers.

Warranty claims should be directed to:

- *An authorized INDIAN MOTORCYCLE dealer, or*
- *INDIAN MOTORCYCLE, 2100 Highway 55, Medina, MN 55340*

EMISSIONS CONTROL SYSTEM WARRANTY

INDIAN MOTORCYCLE COMPANY - EMISSION CONTROL SYSTEM WARRANTY STATEMENT

YOUR WARRANTY RIGHTS AND OBLIGATIONS

The California Air Resources Board and INDIAN MOTORCYCLE are pleased to explain the emission control system warranty on your 2015 or later INDIAN MOTORCYCLE. In California, new motor vehicles must be designed, built and equipped to meet the state's stringent anti-smog standards. INDIAN MOTORCYCLE must warrant the emission control system on your motorcycle for the periods of time listed below provided there has been no abuse, neglect or improper maintenance of your motorcycle. Your emission control system may include parts such as the fuel-injection system, the ignition system, catalytic converter and engine computer. Also included may be hoses, belts, connectors and other emission related assemblies. Where a warrantable condition exists, INDIAN MOTORCYCLE will repair your motorcycle at no cost to you, including diagnosis, parts and labor.

MANUFACTURER'S WARRANTY COVERAGE

Class III motorcycles (280 cm³ and larger): for a period of use of five (5) years or 18,641 miles (30,000 km), whichever first occurs.

If an emission-related part on your motorcycle is defective, the part will be repaired or replaced by INDIAN MOTORCYCLE. This is your emission control system DEFECTS WARRANTY.

MANUFACTURER'S WARRANTY COVERAGE (KOREA)

Class III motorcycles (280 cm³ and larger): for a period of use of two (2) years or 21,747 miles (35,000 km), whichever first occurs.

If an emission-related part on your motorcycle is defective, the part will be repaired or replaced by INDIAN MOTORCYCLE. This is your emission control system DEFECTS WARRANTY.

WARRANTY

OWNER'S WARRANTY RESPONSIBILITIES

As the motorcycle owner, you are responsible for the performance of the required maintenance listed in your Rider's manual. INDIAN MOTORCYCLE recommends that you retain all receipts covering maintenance on your motorcycle, but INDIAN MOTORCYCLE cannot deny warranty solely for the lack of receipts or for your failure to ensure the performance of all scheduled maintenance. You are responsible for presenting your motorcycle to an INDIAN MOTORCYCLE dealer as soon as a problem exists. The warranty repairs should be completed in a reasonable amount of time, not to exceed 30 days. As the motorcycle owner, you should be aware that INDIAN MOTORCYCLE may deny your warranty coverage if your motorcycle or part has failed due to abuse, neglect, improper maintenance or unapproved modifications.

If you have any questions regarding your warranty rights and responsibilities, you should contact INDIAN MOTORCYCLE, 2100 Highway 55, Medina, MN 55340, or the California Air Resources Board, P.O. Box 8001, 9528 Telstar Avenue, El Monte, CA 91734-8001.

INDIAN MOTORCYCLE warrants that each new 2015 and later INDIAN MOTORCYCLE that includes as standard equipment a headlight, taillight and stoplight, and is street legal:

- A. is designed, built and equipped so as to conform at the time of initial retail purchases with all applicable regulations of the United States Environmental Protection Agency, and the California Air Resources Board; and
- B. is free from defects in material and workmanship which cause such motorcycle to fail to conform with applicable regulations of the United States Environmental Protection Agency or the California Air Resources Board for a period of use, depending on the engine displacement, of 7,456 miles (12,000 km), if the motorcycle's engine displacement is less than 170 cm³; of 11,185 miles (18,000 km), if the motorcycle's engine displacement is equal or greater than 170 cm³ but less than 280 cm³; or of 18,641 miles (30,000 km), if the motorcycle's engine displacement is 280 cm³ or greater; or 5 (five) years from the date of initial retail delivery, whichever occurs first.

I. COVERAGE

Warranty defects shall be remedied during customary business hours at any authorized INDIAN MOTORCYCLE dealer located within the United States of America in compliance with the Clean Air Act and applicable regulations of the United States Environmental Protection Agency and the California Air Resources Board. Any part or parts replaced under this warranty shall become the property of INDIAN MOTORCYCLE.

In the State of California only, emission-related warranted parts are specifically defined by the state's Emission Warranty Parts List. These warranted parts are: carburetor and internal parts; intake manifold; fuel tank; fuel injection system; spark advance mechanism; crankcase breather; air cutoff valves; fuel tank cap for evaporative emission controlled vehicles; oil filler cap; pressure control valve; fuel/vapor separator; canister; igniters; breaker governors; ignition coils; ignition wires; ignition points; condensers, and spark plugs if failure occurs prior to the first scheduled replacement; and hoses, clamps, fittings and tubing used directly in these parts. Since emission related parts may vary from model to model, certain models may not contain all of these parts and certain models may contain functionally equivalent parts. In the State of California only, Emission Control System emergency repairs, as provided for in the California Administrative Code, may be performed by other than an authorized INDIAN MOTORCYCLE dealer. An emergency situation occurs when an authorized INDIAN MOTORCYCLE dealer is not reasonably available, a part is not available within 30 days or a repair is not complete within 30 days. Any replacement part can be used in an emergency repair. INDIAN MOTORCYCLE will reimburse the owner for expenses, including diagnosis, not to exceed INDIAN MOTORCYCLE's suggested retail price for all warranted parts replaced and labor charges based on INDIAN MOTORCYCLE's recommended time allowance for the warranty repair and the geographically appropriate hourly labor rate. The owner may be required to keep receipts and failed parts in order to receive compensation.

WARRANTY

II. LIMITATIONS

The Emission Control System Warranty shall not cover any of the following:

A. Repair or replacement required as a result of:

- Accident
- Misuse
- Repairs improperly performed or replacements improperly installed
- Use of replacement parts or accessories not conforming to INDIAN MOTORCYCLE specifications which adversely affect performance and/or
- Use in competitive racing or related events.

B. Inspections, replacement of parts, and other services and adjustments necessary for required maintenance

C. Any motorcycle on which the odometer mileage has been changed so that actual mileage cannot be readily determined.

III. LIMITED LIABILITY

- A. The liability of INDIAN MOTORCYCLE under this Emission Control System Warranty is limited solely to the remedying of defects in material or workmanship by an authorized INDIAN MOTORCYCLE dealer at its place of business during customary business hours. This warranty does not cover inconvenience or loss of use of the motorcycle or transportation of the motorcycle to or from the INDIAN MOTORCYCLE dealer. INDIAN MOTORCYCLE SHALL NOT BE LIABLE FOR ANY OTHER EXPENSES, LOSS OR DAMAGE, WHETHER DIRECT, INCIDENTAL, CONSEQUENTIAL OR EXEMPLARY ARISING IN CONNECTION WITH THE SALE OR USE OF OR INABILITY TO USE THE INDIAN MOTORCYCLE FOR ANY PURPOSE. SOME STATES DO NOT ALLOW THE EXCLUSION OR LIMITATION OF ANY INCIDENTAL OR CONSEQUENTIAL DAMAGES, SO THE ABOVE LIMITATIONS MAY NOT APPLY TO YOU.
- B. NO EXPRESS EMISSION CONTROL SYSTEM WARRANTY IS GIVEN BY INDIAN MOTORCYCLE EXCEPT AS SPECIFICALLY SET FORTH HEREIN. ANY EMISSION CONTROL SYSTEM WARRANTY IMPLIED BY LAW, INCLUDING ANY WARRANTY OF MERCHANTABILITY OR FITNESS FOR A PARTICULAR PURPOSE, IS LIMITED TO THE EXPRESS EMISSION CONTROL SYSTEM WARRANTY TERMS STATED IN THIS WARRANTY. THE FOREGOING STATEMENTS OF WARRANTY ARE EXCLUSIVE AND IN LIEU OF ALL OTHER REMEDIES. SOME STATES DO NOT ALLOW LIMITATIONS ON HOW LONG AN IMPLIED WARRANTY LASTS SO THE ABOVE LIMITATIONS MAY NOT APPLY TO YOU.
- C. No dealer is authorized to modify this INDIAN MOTORCYCLE Limited Emission Control System Warranty.

IV. LEGAL RIGHTS

THIS WARRANTY GIVES YOU SPECIFIC LEGAL RIGHTS, AND YOU MAY ALSO HAVE OTHER RIGHTS WHICH VARY FROM STATE TO STATE.

WARRANTY

V. THIS WARRANTY IS IN ADDITION TO THE INDIAN MOTORCYCLE LIMITED MOTORCYCLE WARRANTY

VI. ADDITIONAL INFORMATION

Any replacement part that is equivalent in performance and durability may be used in the performance of any maintenance or repairs. However, INDIAN MOTORCYCLE is not liable for these parts. The owner is responsible for the performance of all required maintenance. Such maintenance may be performed at a service establishment or by any individual. The warranty period begins on the date the motorcycle is delivered to an ultimate purchaser.

INDIAN MOTORCYCLE

2100 Highway 55

Medina, MN 55340

ATTN: Warranty Department

A

About the Rider's Manual 11

Accelerating 72

Adding Coolant 102

AGM Battery Charger
Recommendations 137

AGM Battery Charging
Recommendations – Deeply
Discharged (Below 3 Volts)..... 138

AGM Battery Charging
Recommendations – Low Charge 138

AGM Battery Charging
Recommendations Table..... 139

AGM Battery Maintenance Tips 139

Air Filter
Replacement 102

Ambient Air Temperature 34

Anti-Lock Brake System (ABS) 49

App Tray 41

Average Fuel Economy 34

B

Back Button 39

Battery 136
Installation 137
Removal 136

Battery Charging and Maintenance 137

Battery Voltage 34

Brake Disc Inspection/Cleaning 128

Brake Fluid 158

Brake Fluid Precautions 123

Brake Hoses/Connections 123

Brake Lever, Front
Lubrication 124

Brake Pad Inspection 127

Brakes
Fluid Level Inspection 57
Front Brake Lever, Lubrication..... 124
Rear 127

Brakes, Front
Brake Pad Inspection 126

Braking 72

Break-In Maintenance 78

C

Carrying a Passenger 15

Chain
Adjustment 107
Alignment 107
Inspection 63

Chain Tension 106-107

Charcoal Canister 120

Checking Oil Level..... 56

Cleaning Products..... 147

Clock 34

Clutch Lever 47
Free Play Adjustment 121
Lubrication 121

Compliance Statement 8

Component Identification 23

Console 24

Control
Left Control 26
Right Control 26

Coolant Level Inspection 101

Cooling System 101

Crankcase Breather Hoses 119

Cruise Control 73
Accelerate 74
Cruise Control Tips 73
Cruise Control, Cancel 74
Decelerate 74
Resume Speed 73
Set Speed 73

Cruise Control Switch 28

D

Diagnostic Functionality 36

Display Units (Standard/Metric) 34

Drive Chain
Adjustment 107
Alignment 107
Inspection 63
Stretch Inspection 107
Tension Specifications 107

Drive Sprocket
Inspection 62

INDEX

E

| | |
|------------------------------------|-----|
| Electrical Precautions | 141 |
| Elevating the Motorcycle | 142 |
| Engine | |
| Oil / Filter Change | 99 |
| Engine Break-In | 65 |
| Engine Error Codes | 35 |
| Engine Identification Number | 7 |
| Engine Oil Recommendation | 158 |
| Engine Protection | 150 |
| Engine Speed | 33 |
| Engine Stop/Run Switch | 30 |
| EVAP system | 120 |
| Evaporative Emissions System | 120 |
| Exhaust System Inspection | 142 |

F

| | |
|--|-----|
| Fastener Inspection | 142 |
| Fastener Torques | 142 |
| Fork Oil | 158 |
| Front Brake Fluid | 125 |
| Front Brake Lever | 50 |
| Front Fork | |
| Adjustment Guide | 115 |
| Front Fork/Suspension Inspection | 114 |
| Front Suspension, Inspection | 61 |
| Front Wheel | |
| Removal / Installation | 128 |
| FTR | |

| | |
|-------------------------------|-----|
| Specifications | 153 |
| Fuel and Exhaust Safety | 17 |
| Fuel Level | 63 |
| Fuel Recommendation | 158 |
| Fuel Stabilizer | 149 |
| Fuel System Components | 119 |
| Fuel Tan | |
| Vent Inspection | 120 |
| Fueling | 66 |
| Fuse Box | |
| Location | 141 |
| Fuses | |
| Location | 141 |
| Replacement | 141 |

G

| | |
|------------------------------------|-----|
| Gauge Screen | 40 |
| Gear Indicator | 34 |
| Gear Shift Lever | 47 |
| Gloss Clear Coat Finish Care | 148 |
| Gross Vehicle Weight Rating | 19 |
| GVWR | 19 |

H

| | |
|------------------------------|-----|
| Headlight | |
| Aim Adjustment | 134 |
| Aim Inspection | 133 |
| Headlight Cowl Removal | 134 |

| | |
|-------------------------|-----|
| Headlight Removal | 135 |
| Horn | 29 |

I

| | |
|------------------------------------|--------|
| Identification Number Record | 8 |
| Idle Shut Down | 69 |
| Ignition/Light Key Switch | 27 |
| Indicator Lamps | 32 |
| Industry Canada ICES-002 | 8 |
| Instantaneous Fuel Economy | 34 |
| Instrument Cluster | 31, 34 |

K

| | |
|---------------------------------|---|
| Key Identification Number | 7 |
|---------------------------------|---|

L

| | |
|-----------------------------|-----|
| LUBRICANTS AND FLUIDS | 161 |
|-----------------------------|-----|

M

| | |
|----------------------------------|-----|
| Maintenance | 78 |
| Maintenance During Storage | 150 |
| Maintenance Intervals | 79 |
| Maintenance Log | 171 |
| Maintenance, Major | 78 |

Matte Clear Coat Finish Care 149
 Mechanical Clutch, Inspection 61
 MFD Tell-Tales 33
 Mirrors 48-49
 Misfire Detection..... 36
 Modifications 16
 Motorcycle Noise Regulation 164
 Multi-Function Display (MFD)..... 33
 Music Screen..... 40

N

Noise Emission Warranty..... 164

O

Odometer 33
 Oil Change
 Checking Oil Level..... 56
 Oil Change Procedure 99
 Oil Level
 Check 56
 Operating Motorcycle Outside the U.
 S.A. 7
 Operating Speeds and Gears 66
 Operation 65
 Over Temperature Display and
 Warning Indicator..... 36

P

Park and Cover the Motorcycle 150
 Parking 74
 Parking on a Slope 74
 Parking on a Soft Surface 74
 Parking the Motorcycle 16
 Periodic Maintenance 78
 Severe Use Definition..... 78
 Phone Screen 41
 Pre-Ride Inspections..... 53
 Brake Lines 60
 Fasteners 63
 Front Brake Lever, Inspection 60
 Rear Brake Pedal, Inspection..... 60
 Side-stand 63
 Throttle 61
 Tire Condition 57
 Tires 57, 130
 Priming the Fuel System..... 67
 Protective Apparel 14

R

Rear Brake Fluid 123
 Rear Brake Pad
 Inspection..... 127
 Rear Brake Pedal..... 50, 122
 Rear Cylinder Deactivation..... 36
 Rear Shock
 Adjustment Guide 110

Rear Suspension, Inspection 61
 Removal From Storage 151
 Reporting Safety Defects 19
 RIDE COMMAND
 Bluetooth® Pairing 45
 Ride Modes..... 42
 Right Side Menu Bar Indicators..... 41
 Settings 44
 Traction Control..... 43
 Update Software..... 45
 USB Port (if equipped) 46
 Ride Command Display 37
 Ride Height
 Adjustment 110
 Inspection..... 109
 Right Trigger..... 38
 Road Tests 78
 Rodents 150

S

Saddlebags..... 16
 Safe Riding Practices 11
 Motorcycling Has Inherent Risks..... 11
 Safety During Service Procedures..... 77
 Safety Labels..... 20
 Safety Maintenance 18
 Safety Symbols and Signal Words 4
 Seat
 Installation 132
 Removal 131

INDEX

| | |
|---------------------------------------|------------|
| Select Joystick | 39 |
| Service Information | 7 |
| Service Intervals | |
| Maintenance | 79 |
| Shift Point, Recommended | 71 |
| Shifting Gears..... | 69 |
| Shifting Gears While Stationary | 70 |
| Shock, Rear | |
| Preload Adjustment | 110 |
| Preload Inspection | 109 |
| Side Stand Lubrication | 122 |
| Side-stand | 48 |
| Spark Plugs | 133 |
| Specifications | 158 |
| Drive Chain..... | 107 |
| FTR..... | 153 |
| Speedometer | 32 |
| Starting the Engine..... | 68 |
| Steering Head Inspection | 118 |
| Stopping the Engine | 72 |
| Storage Area Preparation | 149 |
| Suspension Adjustment | |
| Front Fork | 115 |
| Rear Shock..... | 110 |
| Swing Arm/Rear Axle Inspection | 113 |
| Switches | 25, 28, 30 |
| Hazard Switch..... | 28 |
| Turn Signals | 28 |

T

| | |
|-----------------------------------|---------|
| Throttle Control Grip | 46 |
| Throttle Control Inspection | 119 |
| Tire Condition | 130 |
| Tire Inflation..... | 150 |
| Tire Pressure | 57, 130 |
| Tire Replacement..... | 130 |
| Tire Tread Depth..... | 57, 130 |
| Tires | 57, 130 |
| Transporting the Motorcycle..... | 17 |
| Trigger Switches..... | 30 |
| Trip Odometer | 33 |
| Troubleshooting | 143 |

V

| | |
|------------------------------------|----|
| Vehicle Emission Information | 20 |
|------------------------------------|----|

W

| | |
|------------------------------------|-----|
| Warranty | 159 |
| Warranty Information..... | 7 |
| Washing the Motorcycle..... | 147 |
| Wheel Alignment | 128 |
| Wheel Inspection..... | 128 |
| Wheel, Front | |
| Removal / Installation | 128 |
| Wheelie Mitigation..... | 48 |
| Windshield Care (if equipped)..... | 148 |

To locate your nearest dealer,
visit www.indianmotorcycle.com

INDIAN MOTORCYCLE
2100 Highway 55
Medina, MN 55340
Phone: 1-877-204-3697
French: 1-800-268-6334

Part No. 9931166 Rev 02
Printed in U.S.A.

