

# ENG

# USER MANUAL

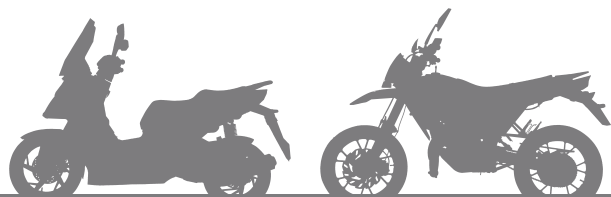

# INTRODUCTION

Thanks for your purchasing of this vehicle. This model is designed for safety, built for durability, and perfected for daily street use. The unique vehicle design, enrich of stylish and peronality, represents your outstanding taste and favor to pursue the state of the art living attitude.

This manual describes the correct usage of this motorcycle including safety riding, simple inspection methods and so on. For a more comfortable and safety riding, please read this manual carefully. If any questions concerning the operation or maintenance of your vehicle, please consult a dealer.

# IMPORTANT MANUAL INFORMATION

In this manual with some important information is distinguished by the following notations:

## WARNING

It is **WARNING** instructions that need to follow, failure of follow could be end in result severe injury or lead to death to the operator.

## CAUTION

A **CAUTION** indicates with special precautions to avoid damage to the vehicle.

## CAUTION

- Please always put this manual with vehicle for rider maintenance/ dealer tracking of service records even if vehicle is being sold.
- This manual contains the most of the vehicle information, however, the maker will continually improve it's product design and quality that lead to difference between the manual and vehicle . If you have any questions concerning this manual, please consult your dealer.

## WARNING

FOR YOUR OWN SAFETY, PLEASE READ THIS MANUAL CAREFULLY BEFORE OPERATION THIS VEHICLE. ONLY OPERATE THE VEHICLE UNTIL YOU HAVE COMPLETELY AWARE OF ADEQUATE KNOWLEDGE OF CONTROLS AND OPERATION FEATURE AND YOU HAVE BEEN TRAINED IN SAFE AND PROPER RIDING TECHNIQUES. PERIODIC INSPECTIONS, WELL MAINTENANCE AND GOOD RIDING SKILLS, WILL ENSURE YOUR SAFETY RIDING AND INCREASE THE PRODUCT RELIABILITY OF THIS VEHICLE.

\*Product and specifications are subject to change without notice.

# IMPORTANT MANUAL INFORMATION

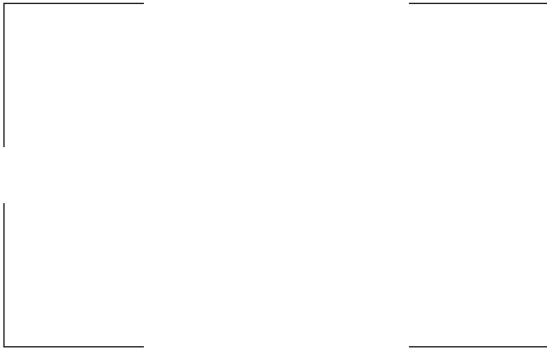

Dealer label here

# TABLE OF CONTENTS

<b>SAFETY INFORMATION</b> .....	<b>5</b>	Braking.....	21	<b>TROUBLESHOOTING</b> .....	<b>37</b>
Other safetyriding points.....	6	Engine break-in.....	22	Troubleshooting chart.....	38
Location of labels.....	8	Parking.....	22	<b>CLEAN AND STORAGE</b> .....	<b>39</b>
<b>DESCRIPTION</b> .....	<b>9</b>	<b>PERIODIC MAINTENANCE AND</b>		Cleaning.....	39
Side view.....	9	<b>MINOR REPAIR</b> .....	<b>23</b>	Storage.....	40
Controls and instruments.....	10	Spark plug.....	23	<b>SPECIFICATIONS</b> .....	<b>42</b>
<b>INSTRUMENT AND CONTROL</b>		Engine oil.....	25	<b>CONSUMER INFORMATION</b> .....	<b>44</b>
<b>FUNCTIONS</b> .....	<b>11</b>	Air cleaner.....	25	Identification numbers.....	44
Main switch.....	11	Carburator.....	26	<b>GEWÄHRLEISTUNG UND</b>	
Indicator and warning light.....	11	Checking the throttle cable free play.....	26	<b>WARRANTY INFORMATION</b> .....	<b>45</b>
Handlebar switches - left.....	12	Checking the clutch lever free play.....	26	<b>MAINTENANCE SCHEDULE</b> .....	<b>46</b>
Handlebar switches - right.....	13	Tires.....	26	<b>SERVICE PLAN</b> .....	<b>47</b>
Brake pedal.....	13	Tire air pressure.....	27	<b>WIRING DIAGRAM</b> .....	<b>48</b>
Shift lever.....	13	Tire inspection.....	27	<b>SPACE FOR NOTES</b> .....	<b>49</b>
Steering lock.....	14	Rims.....	28		
Fuel cock.....	14	Controle the brake lever and brake			
Fuel tank cap.....	15	pedal free play.....	28		
Fuel.....	15	Brake fluid.....	30		
Catalytic converter.....	16	Throttle grip and cable.....	31		
Tool kit.....	16	Lubricate the front and rear brake.....	31		
Side stand.....	16	Front fork.....	31		
Main stand.....	17	Steering.....	32		
<b>PRE-OPERATION CHECKS</b> .....	<b>18</b>	Wheel bearings.....	32		
Pre-operation check list.....	19	Drive chain.....	32		
<b>OPERATION AND IMPORTANT</b>		Tensioning the drive chain.....	33		
<b>RIDING POINTS</b> .....	<b>20</b>	Battery.....	33		
Starting the engine.....	20	Fuse.....	34		
Stop the engine.....	20	Headlight.....	35		
Starting off.....	21	Front indicator.....	35		
Shifting and riding.....	21	Rear indicator.....	35		
Acceleration and deceleration.....	21	Tail/brake and licenes plate light.....	36		

# SAFETY INFORMATION

THIS Vehicle ARE TWO WHEEL SINGLE TRACK VEHICLES. THE USE OF SAVETY AND OPERATION MAY IN DIFFERENT RESULT BY THE USE OF PROPER RIDING TECHNIQUES OF THE OPERATOR.

TO REMIND OF OPERATOR, WHO SHOULD KNOW THE FOLLOWING REQUIREMENTS BEFORE RIDING.

HE OR SHE SHOULD:

- WELL TRAINED AND FAMILIAR TO ALL THE ASPECTS OF Vehicle OPERATION.
- FULLY READ AND AWARE OF MAINTENANCE REQUIREMENTS THAT NOTED IN THIS OWNER'S MANUAL.
- OBTAIN QUALIFIED TRAINING & LEGAL LICENSE FOR OPERATION OF THIS VEHICLE.
- WELL AND PROFESSIONAL MAINTENANCE SERVICE FOR OPERATOR AND CERTIFICATED REPAIR SHOP/DEALER TO ACQUIRE GOOD MECHANICAL CONDITIONS OF VEHICLE.

## Safe riding

- Always pre-check your vehicle before riding is key point to prevent an accident.
- Please follow the maximum loads limited of operator and passenger.
- Most of accident on the motorists is caused by automobile driver who "failure to recognize out the vehicle" and caused mobile/vehicle accidents. Therefore, to make yourself conspicuous appear to public will be very effective in reducing the change of this kind of accidents.

## Therefore:

- Wear a brightly colored and protective clothes/Jacket
- Operate the turning signals before turning and slow down the Speed when approaching and passthrough the intersection
- Keep proper distance with other Motorists, and let them aware of your location
- Know your skills and limits

- Never lend your vehicle to others who not qualified for riding
- Always follow the legal speed limit on the vehicle and traffic law
- The posture of the operator and passenger is important for proper control. properly riding posture can Keep vehicle in balance while riding.
  - Operator should sit up-right with two hand hold on handle bar, foot on floorboard while driving.
  - Passenger should make sure that he/she can firmly hold on grip or operator with foot step on footrest.
- Driving after Alcohol drink or other illegal drugs is strictly prohibited.
- This vehicle is designed for onroad use only. It is not suitable for off-road use.

## Protective clothing

Properly clothing yourself will keep you safety from potential accidents:

- Always wear an approved helmet.
- With face shield to protect your eye from dust and rain drop.

# SAFETY INFORMATION

- The wear of proper jacket, shoes, groves etc., can be better protection, reducing the degree of injury from un-expected accident.
- Never wear loose-fitting clothes, otherwise they could catch on the control levers or wheels and cause injury or an accident.
- Never touch the engine or exhaust system during or after operation. They become very hot and can cause burns. Always wear protective clothing that covers your legs, ankles, and feet.

## Modifications

Modifications made to this vehicle that not approved by maker, or the removal of original equipment, may let vehicle unsafe for use and cause severe personal injury. Modifications may also make your vehicle illegal touse.

## Loading and accessories

Adding accessories or cargo to your vehicle may cause the different on the weight distribution of vehicle and influence on the steering & balance.

It may cause possibility of an accident, please extremely caution and follow below limitation when you equipped with accessories. Below are some general or accessories. Here are some guidelines to follow if loading cargo or adding accessories to your vehicle.

## Loading

The total weight of the operator, passenger, accessories and cargo must not exceed the maximum load limit..

**Maximum load  
(not include the vehicle):  
155kg**

When loading within this weight limit, keep the following in mind:

- Cargo and accessory weight should be kept as low and close to the vehicle as possible. Make sure to distribute the weight as evenly as possible on both sides of the vehicle to minimize imbalance or instability.
- Make sure that accessories and cargo are securely attached to vehicle before riding

- Never attach any large or heavy items to the handlebar, front fork, or front fender. Such items can create unstable handling or a slow steering response.

## Accessories

Genuine accessories have been specifically designed for use on this vehicle. If need, please contact with dealer for detail. Since the maker can not test all other accessories , you must personally be responsible for the proper selection, installation and use of non-OEM accessories.

Keep the following guidelines in mind, when mounting accessories.

- Never install accessories or carry cargo that would influence on the ground clearance, limit suspension travel, steering, or obscure lights or turning lights, reflectors.
- Accessories on the handle bar/front suspension area will cause bad influence on steering the vehicle. if you will install accessories, please keep it as light in weight and not interfere on steering the vehicle.

# SAFETY INFORMATION

- This vehicle is for On-Road transportation purpose only, please do not install any of extended cargo carrier as sulky, that will make vehicle unstable in cross winds and vehicle turns.
  - While equip with electrical accessories, please consult with qualified stores, to make sure such items will not exceed the capacity of the vehicle's electrical system. Unproper install of such items may cause a dangerous loss of lights, lower engine power or even damage the vehicle.
- Gasoline and exhaust gas**
- **GASOLINE IS HIGHLY FLAMMABLE:**
    - Always turn the engine off when refueling.
    - Take care not to spill any gasoline on the engine (hot) or exhaust system when refueling.
    - Do not smoke or use Mobile phone while re-fueling.
  - Never start the engine or let it run for any length of time in a closed area. The exhaust fumes are poisonous and may cause loss of consciousness and death within a short time.
  - Always turn the engine off before leaving the vehicle and remove the key from the main switch. When parking the vehicle, please note the following:
    - The engine and exhaust system remain hot, therefore, park the vehicle in a place where pedestrians or children are not likely to touch these hot areas.
    - Do not park the vehicle on a slope or soft ground, otherwise it may fall over.
    - Do not lay your vehicle to near flammable place.
  - In case of swallow any gasoline, or gasoline get into your eyes, please see your doctor immediately. Keep away the gasoline to your skin and water.

## **Other safe-riding points**

- Turn the signal before making turns.
- When raining or across on run on the wet road, Iron Plates, keep your speed low, slightly using braking to avoid slipping or even fall down.
- Be careful when passing parked cars. A driver might not see you and open a door in your path.



# SAFETY INFORMATION

## LOCATION OF LABEL

### 1. LABEL, ANTI-TAMPERING

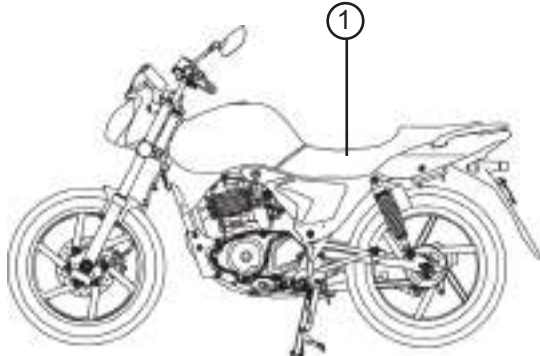

### 1. LABEL, ANTI-TAMPERING

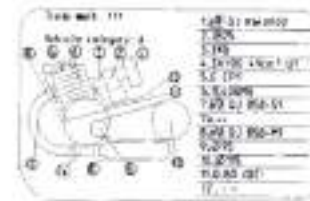

Symbol image

## SIDE VIEW

1. Front wheel
2. Front brake caliper
3. Front turn signal light
4. Rear turn signal light
5. Rear wheel
6. Pedal
7. Side stand
8. Main stand
9. Clutch pedal
10. Air filter
11. Fuel tank cap
12. Tail/brake light
13. Seat
14. Headlight
15. Spark plug

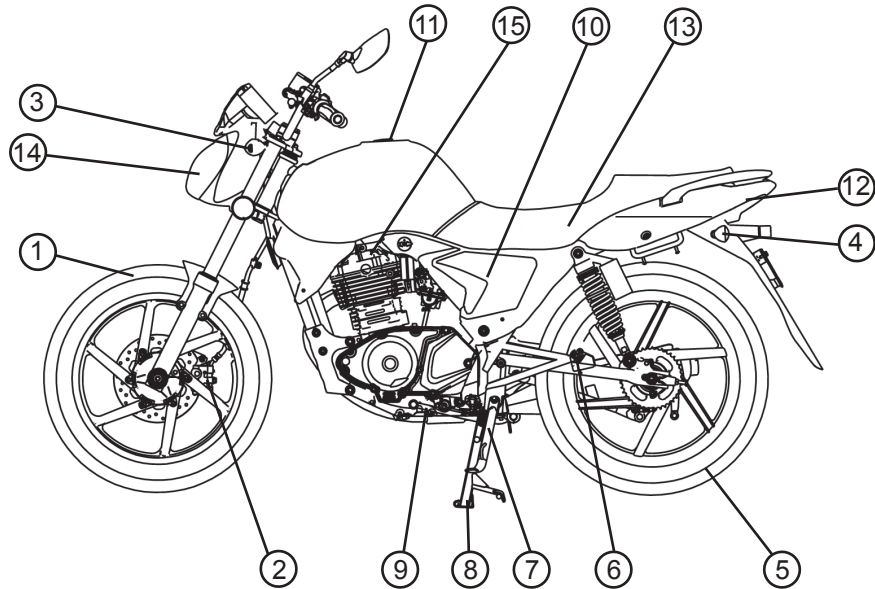

## CONTROLS AND INSTRUMENTS

- 16. Clutch lever
- 17. Left handlebar switches
- 18. Speedometer
- 19. Fuel gauge
- 20. Right handlebar switches
- 21. Front brake lever
- 22. Throttle grip
- 23. Main switch
- 24. Rear pedal brake
- 25. Clutch pedal

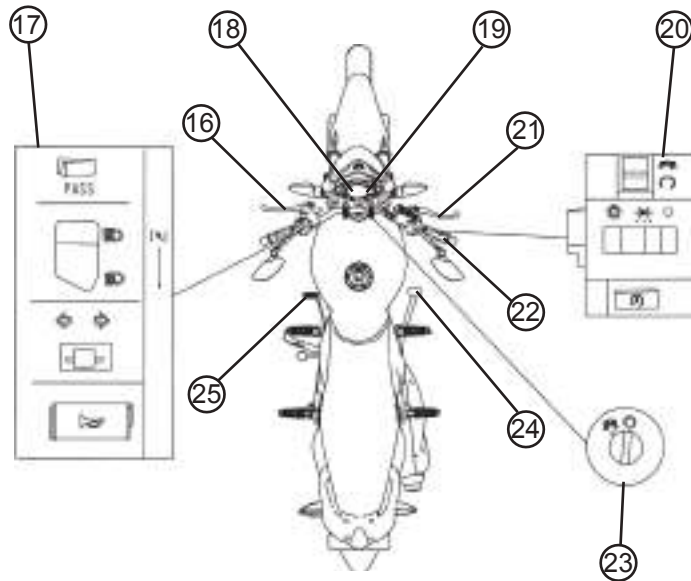

# INSTRUMENT AND CONTROL FUNCTIONS

## MAIN SWITCH

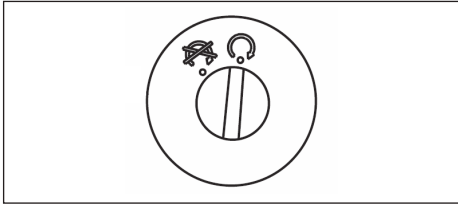

The main switch controls the ignition and lighting systems. The various positions are described as below.

### ON



All electrical circuits are supplied with power, the engine can be started. The key cannot be removed.

### OFF

All electrical systems are off. The key can be removed.

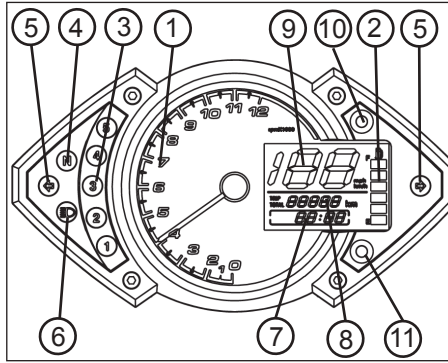
## INDICATOR AND WARNING LIGHTS



1. Rev counter
2. Fuel gauge
3. Gear indicator
4. Neutral indicator lamp **N**
5. Turn signal indicator lamps 
6. Main-beam indicator lamp 
7. Clock
8. Odometer/Tripmaster
9. Speedometer
10. ADJ-button
11. SEL-button

### Rev counter

Displays the engine speed in RPM.

### Fuel gauge

Displays how much fuel remains in the fuel tank.

### Gear indicator

Indicates which gear is currently engaged. In neutral (N), no light is lit.

### Neutral indicator lamp (N)

Lights up whenever neutral (N) is selected.

### Turn signal indicator lamps

The relevant indicator lamp flashes whenever you activate the turn signals.

### Main-beam indicator lamp

Lights up whenever main beam is switched on.

# INSTRUMENT AND CONTROL FUNCTIONS

## Clock

Displays the time of day.

## Odometer/Tripmaster

Displays total distance travelled or the trip meter (Tripmaster).

Tripmaster: Displays the trip meter. The Tripmaster is reset by pressing the ADJ button for 3 seconds. Please note that this function is available only when the TRIP function is active.

## Speedometer

Displays the current speed.

## ADJ-button



Toggles the display between km/h and mph or resets the Tripmaster to 0.

## SEL-button

Toggles between main odometer and trip meter. Pressing and holding the SEL button enables you to set the time. Using SEL, select the hour or second figure and adjust the value using ADJ.

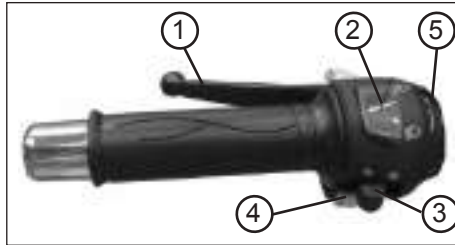
## SWITCHES HANDLEBAR - LEFT





1. Clutch lever
2. Light switch 
3. Turn signal switch 
4. Horn button 
5. Choke



## Clutch lever

Pulling the clutch lever disconnects the transmission from the engine.

## Light switch

By toggling the position of the switch, you can change between main beam  and dipped beam .

## Turn signal switch

By changing the position of the switch, you can indicate left  or right . With the switch in the centre position, the turn signals are switched off.

## Horn button

Sounds the horn.

## Choke

Twisting opens or closes the choke.

# INSTRUMENT AND CONTROL FUNCTIONS

## SWITCHES HANDLEBAR - RIGHT

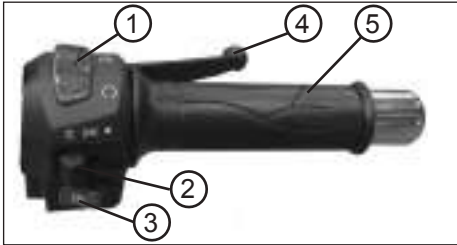

1. Engine - ON / OFF
2. Light switch / / /
3. Electric starter switch
4. Front brake
5. Throttle grip

### Engine - ON / OFF

By toggling the position of the switch, you can switch the engine on and off .

Caution when starting the vehicle.

### Light switch / / /

Change the switch position to select lights OFF , position lights and normal lights .

Caution: Control illumination, main beam, dipped beam and rear light function only in the latter switch position.

### Electric starter switch

Pull the clutch lever in and press the electric starter switch to start the vehicle.

Caution: Operate the starter for no more than 5 seconds.

#### CAUTION

At the same time you have to pull the right brake lever to start the vehicle. For starting the vehicle read the notes in manual.

### Front brake

Pull to operate the front brake.

### Throttle grip

Twist back to increase throttle and forwards to reduce throttle.

## BRAKE PEDAL

The brake pedal (1) is located on the right-hand side of the vehicle and operates the rear brake. Familiarise yourself with how it works before you ride the vehicle on public roads. Novices and returning riders are recommended to take a riding techniques course.

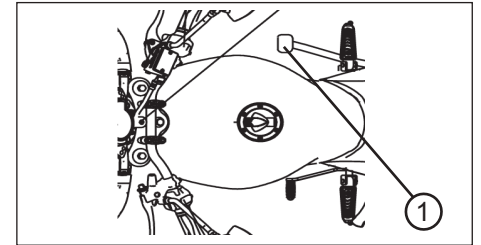

## SHIFT LEVER

The foot-operated gear lever (1) is located on the left side of the vehicle. The vehicle is equipped with a 5-speed manual transmission.

# INSTRUMENT AND CONTROL FUNCTIONS

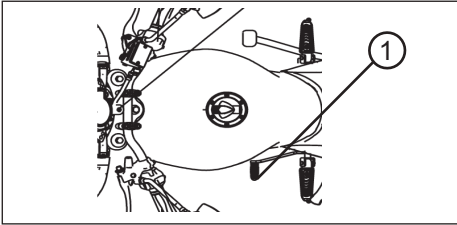

## STEERING LOCK

The steering lock (1) is located on the front right of the steering head between the two fork bridges. To use it, it is necessary to turn the handlebars to the left, insert the ignition key, press the key down gently and turn it to the right.

### CAUTION

To rule out the risk of a serious accident, disengage the steering lock before you start the vehicle.

To rule out the risk of serious damage or injury, you should familiarise yourself with this type of transmission before you start the vehicle.

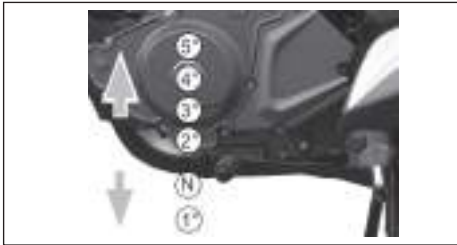

### CAUTION

Never attempt to change gear without releasing the clutch. Novices and returning riders are recommended to take a riding techniques course.

## FUEL COCK

### 1. OFF

No petrol can flow from the fuel tank to the carburettor. Always turn the petrol tap to the OFF position as soon as you have parked the vehicle.

### 2. ON

Turn the petrol tap to this position before you attempt to start the vehicle. Petrol flows from the fuel tank to the carburettor.

### 3. RESERVE

Irregular vehicle behaviour is often caused by a lack of fuel. In this event, turn the petrol tap to the RES position. If you need to do this, visit a filling station at the earliest opportunity to refuel.



# INSTRUMENT AND CONTROL FUNCTIONS

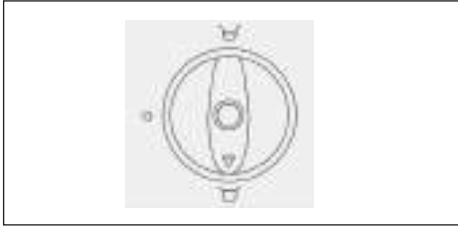

## CAUTION

After refuelling, always turn the petrol tap back to the ON position.

## FUEL TANK CAP

To remove the fuel tank cap (1)

Turn it 1/4 turn counterclockwise. The lock will be released and the fuel tank cap can be removed.

To install the fuel tank cap (1)

In reverse order.

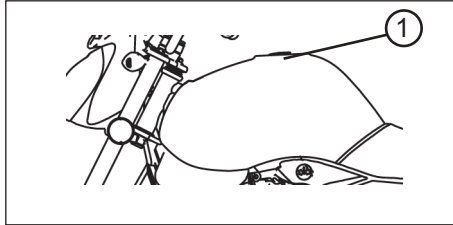

## CAUTION

Make sure that the fuel tank cap is properly closed and locked before riding.

## FUEL

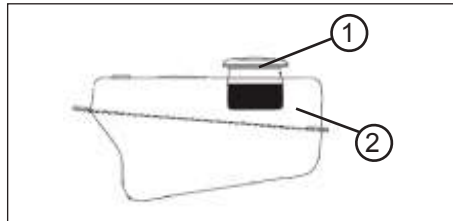

1. Fuel tank filler tube
2. Fuel level

Make sure that there is sufficient fuel in the tank. Fill the fuel tank to the bottom of the filler tube as shown.

## WARNING

- Do not overfill the fuel tank, otherwise it may overflow when the fuel warms up and expands.
- Avoid spilling fuel on the hot engine.

## CAUTION

Immediately wipe off spilled fuel with a clean, dry, soft cloth, since fuel may damage the painted surfaces or plastic parts.



# INSTRUMENT AND CONTROL FUNCTIONS

**Regular unleaded gasoline only.  
Recommended fuel: 95 oct  
16l +/- 0.5l**

**!!CAUTION!!  
BIOETHANOL E10 IS NOT SUITABLE**

## CATALYTIC CONVERTER

This model is equipped with a catalytic converter in the exhaust system.

### **⚠ WARNING**

The exhaust system is hot after operation. Make sure that the exhaust system has cooled down before doing any maintenance work.

### **CAUTION**

The following precautions must be observed to prevent a fire hazard or other damages.

- Use only unleaded gasoline. The use of leaded gasoline will cause unrepairable damage to the catalytic converter.
- Never park the vehicle near possible fire hazards such as grass or other materials that easily burn.
- Do not allow the engine to idle too long.

## TOOL KIT

With the vehicle you also get a set of tools for minor repairs.

## SIDE STAND

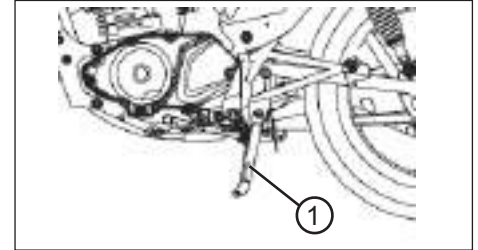

The side stand (1) is located on the left side of the Vehicle. Release the side-stand by using your feet to step on the bracket of side stand to up-right position to stand the vehicle.

### **CAUTION**

- The side stand with auto-rebound system. Make sure your vehicle have been park well are stable enough to stand the vehicle.
- Please avoid to use side stand to park the vehicle on the slope, soft land or un-flat ground.

# INSTRUMENT AND CONTROL FUNCTIONS

## MAIN STAND

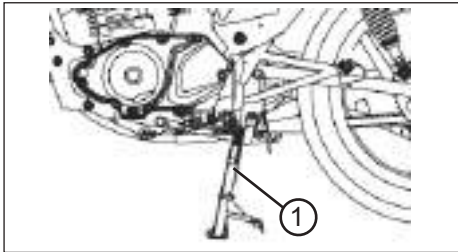

The main stand (1) is located on the left side of the Vehicle. Release the side-stand by using your feet to step on the bracket of side stand to up-right position to stand the vehicle..

### CAUTION

- The side stand with auto-rebound system. Make sure your vehicle have been park well are stable enough to stand the vehicle.

# PRE-OPERATION CHECKS

The condition of a vehicle is the owner's responsibility. The operator should check the vehicle by simple but thorough inspection, to make sure of vehicle condition, quick inspect some key and important parts, to prevent the vehicle from serious consequence/accident. Please carefully check the following points before each ride.

## CAUTION

Pre-operation checks should be made each time the vehicle is used. Such an inspection can be accomplished in a very short time; and the added safety it assures is more than worth the time involved.

## WARNING

**If any item in the Pre-operation check list is not working properly , have it inspected and repaired before operating the vehicle. If failed to be corrected by yourself, please turn to repair shop immediately.  
If failed to be corrected by yourself, please turn to repair shop immediately.**

# PRE-OPERATION CHECKS

## PRE-OPERATION CHECK LIST

CHECKPOINT	TO VERIFY
Fuel	<ul style="list-style-type: none"> <li>• Check fuel level in fuel tank.</li> <li>• Refuel if necessary.</li> <li>• Check fuel line for leakage.</li> </ul>
4-stroke engine oil	<ul style="list-style-type: none"> <li>• Check oil level in oil tank.</li> <li>• If necessary, add recommended oil to specified level.</li> <li>• Check vehicle for oil leakage.</li> </ul>
Final transmission oil	<ul style="list-style-type: none"> <li>• Check vehicle for oil leakage.</li> </ul>
Front brake	<ul style="list-style-type: none"> <li>• Check operation.</li> <li>• If soft or spongy, have dealer bleed hydraulic system.</li> <li>• Check brake pads for wear.</li> <li>• Replace if necessary.</li> <li>• Check fluid level in reservoir.</li> <li>• If necessary, add recommended brake fluid to specified level.</li> <li>• Check hydraulic system for leakage.</li> </ul>
Rear brake	<ul style="list-style-type: none"> <li>• Check operation.</li> <li>• Lubricate cable if necessary.</li> <li>• Check lever free play.</li> <li>• Adjust if necessary.</li> </ul>
Throttle grip	<ul style="list-style-type: none"> <li>• Make sure that operation is smooth.</li> <li>• Check cable free play.</li> <li>• If necessary, have dealer adjust cable free play and lubricate cable and grip housing.</li> </ul>
Wheels and tires	<ul style="list-style-type: none"> <li>• Check for damage.</li> <li>• Check tire condition and tread depth.</li> <li>• Check air pressure.</li> </ul>
Brake levers	<ul style="list-style-type: none"> <li>• Make sure that operation is smooth.</li> <li>• Lubricate lever pivoting points if necessary.</li> </ul>
Main stand	<ul style="list-style-type: none"> <li>• Make sure that operation is smooth.</li> <li>• Lubricate pivot if necessary.</li> </ul>
Chassis fasteners	<ul style="list-style-type: none"> <li>• Make sure that all nuts, bolts and screws are properly tightened.</li> <li>• Tighten if necessary.</li> </ul>
Instruments, lights, signals and switches	<ul style="list-style-type: none"> <li>• Check operation</li> <li>• Correct if necessary</li> </ul>

# OPERATION AND IMPORTANT RIDING POINTS

## **⚠ WARNING**

- Before riding the vehicle, please make sure that you are fully familiar with all operating controls & their functions before riding. To consult a dealer shop if you not thoroughly understand.
- Please do not start the engine in a closed area, the exhaust air are poisonous, and inhaling them can cause loss of consciousness and even death in short time.



## STARTING THE ENGINE

### **CAUTION**

Note the point „Engine break in“ before you start to riding the vehicle.



### Starting with the e-starter

- Turn the key to ON .
- Pull the right brake lever otherwise the vehicle will not start.
- Push the start switch button  (1) for a few seconds.

### **CAUTION**

Do not crank the engine more than 5 seconds on any one attempt.

### **CAUTION**

If the vehicle does not start, wait another 5 seconds before attempting to start again. The engine should always reach operating temperature before you increase speed.

## STOP THE ENGINE

1. Reduce the throttle to 0 position.
2. Pull the clutch lever
3. Switch the gear to N - neutral
4. Operate the brakes
5. After the vehicle is stopped turn off the ignition.

### **CAUTION**

Before starting off allow the engine to warm up otherwise the spark plug and engine can be damaged early.

# OPERATION AND IMPORTANT RIDING POINTS

## STARTING OFF

1. Pull the clutch lever
2. Shift the engine to the first gear
3. Slowly release the clutch lever and open the throttle at the same time.

## SHIFTING AND RIDING

### a) Shifting gears upwards

1. Release the throttle
2. Pull the clutch lever
3. Lift the gear lever upwards to change to the higher gears.
4. Slowly release the clutch lever and open the throttle at the same time.

### b) Shifting gears downwards

1. Release the throttle
2. Operate the brakes and reduce the speed to an appropriate speed.
3. Pull the clutch lever
4. Lift the gear lever downwards to change to the lower gears.
5. Slowly release the clutch lever and open the throttle at the same time.

#### WARNING

Always switch one gear only, otherwise the transmission can be damaged.

## ACCELERATION AND DECELERATION

The speed can be adjusted by opening and closing the throttle. To increase the speed turn the throttle grip in direction (a). To reduce the speed turn the throttle grip in direction (b).

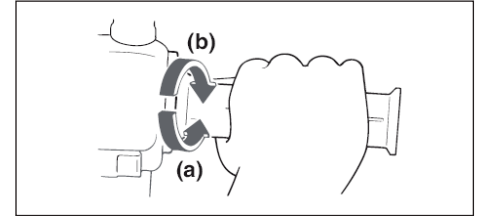

## BRAKING

1. Release the throttle.
2. Apply the front and rear brake at the same time.
3. Apply the clutch lever gradually increasing the pressure.

#### WARNING

- **Avoid hard or sudden braking (especially when cornering) otherwise the motorcycle may skid.**
- **Railroad crossings, street-car rails, iron plates on road construction sites, and manhole covers become extremely slippery when wet.**

# OPERATION AND IMPORTANT RIDING POINTS

- Therefore slow down when approaching such areas and cross them with caution.
- Im Extremfall könnte die Bremse ausfallen.
- Nehmen Sie sich Zeit, um das Bremssystem kennenzulernen..

## ENGINE BREAK IN

Since the engine is brand new, do not put an excessive load on it for the first 1000 km. The various parts in the engine wear and polish themselves to the correct operating clearances.

During this period, prolonged full-throttle operation or any condition that might result in engine overheating must be avoided.

### CAUTION

If any engine trouble should occur during the engine break-in period, immediately have a dealer check the vehicle.

## PARKING

When parking, stop the engine, and then remove the key from the main switch.

### ⚠ WARNING

Since the engine and exhaust system can become very hot, park in a place where pedestrians or children are not likely to touch them.

Do not park on a slope or on soft ground, otherwise the vehicle may overturn

# PERIODIC MAINTENANCE AND MINOR REPAIR

## CAUTION

Sicherheit und Zustand des Fahrzeuges hängen von der richtigen Wartung, regelmäßigen Inspektionen, Einstellung und Schmierung ab.

Auf den nachfolgenden Seiten finden Sie die entsprechenden Hinweise.

Wartung, Austausch oder Reparatur des Abgassystems dürfen nur von einem Fachbetrieb entsprechend der örtlichen Regelungen durchgeführt werden.

## ⚠ WARNING

Überlassen Sie Wartungsarbeiten, mit denen Sie nicht vertraut sind oder solche, die den Garantieanspruch beeinflussen dem autorisierten Fachhändler.

## SPARK PLUG

The spark plug is an important engine component, which is easy to check. Since heat and deposits will cause any spark plug to slowly erode, the spark plug should be removed and checked in accordance with the periodic maintenance and lubrication chart. In addition, the condition of the spark plug can reveal the condition of the engine.

The spark plug (1) is on the left front of the vehicle.

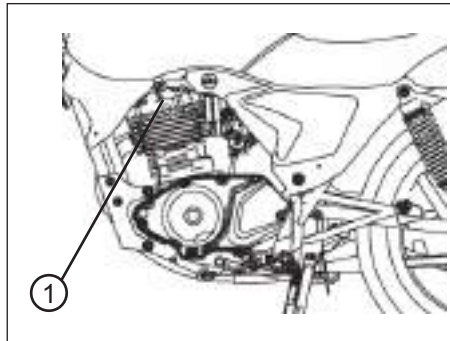

## REMOVE THE SPARK PLUG

1. Remove the spark plug cap
2. Remove the spark plug, with the spark plug wrench included in the owner's tool kit.
3. Check that the porcelain insulator (1) around the center electrode of the spark plug is a medium-to-light tan (the ideal color when the vehicle is ridden normally).

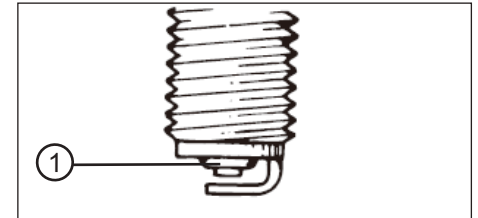



# PERIODIC MAINTENANCE AND MINOR REPAIR

## CAUTION

If the spark plug shows a distinctly different color, the engine could be operating improperly. Do not attempt to diagnose such problems yourself. Instead, have a dealer check the vehicle.

4. Check the spark plug for electrode (2) erosion and excessive carbon or other deposits, and replace it if necessary.

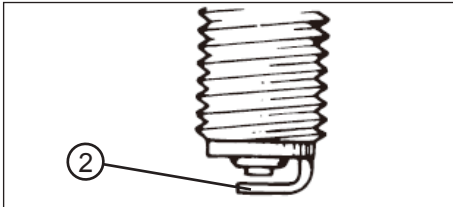

**Specified spark plug:  
NHSP LD - B7RC  
NGK - DR8EA**

## ⚠ WARNING

Please note that no other spark plug model is allowed. Using a different spark plug model can immediately lead to engine damage.

5. Measure the spark plug gap with a wire thickness gauge and, if necessary, adjust the gap to specification. Clean the surface of the spark plug gasket and its mating surface, and then wipe off any grime from the spark plug threads.
6. Install the spark plug with the spark plug wrench, and then tighten it to the specified torque.

**Spark plug gap: 0,6 - 0,7 mm**

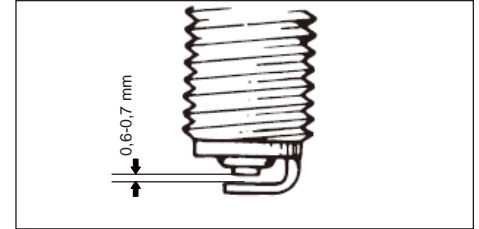

## ⚠ WARNING

Please note the max. torque when inserting the plug. If you do not have the ability to control you leave control of the spark plug to the dealer.

**Tightening torque: 12 Nm**

# PERIODIC MAINTENANCE AND MINOR REPAIR

## ENGINE OIL

Use a high-quality engine oil and change it regularly to extend the life of your engine. Check the oil level at every refuelling stop and top up the oil in good time. To check the oil level, run the engine for a few minutes then switch it off and wait one minute:

- Position the vehicle on its centre stand and check the oil level at the sight glass illustrated above. The oil level must be between the MAX (1) and MIN (2) marks.
- In dusty, cold or poor road conditions, the condition of the oil deteriorates more rapidly. Oil changes should therefore be carried out more frequently.

**Recommended engine oil:**  
**Castrol Power 1 Racing 4T 10W40**  
**Full: 1,2 l / Change: 1 l**

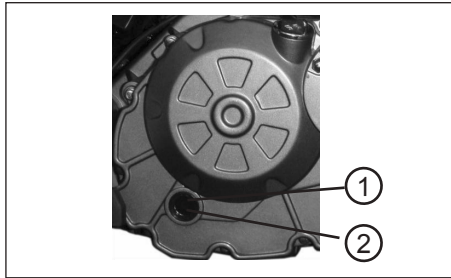

## OIL CHANGE

The engine oil can be topped up whenever this is needed but oil changes and oil filter replacements should be carried out by the specialist dealer because failure to carry out this work correctly could result in engine damage.

### WARNING

- Make sure that no foreign material enters the final transmission case.
- Make sure that no oil gets on the tire or wheel.

## PETROL FILTER

The petrol filter is located directly next to the petrol tap underneath the fuel tank. Handling the petrol filter is hazardous as petrol may escape. Have the replacement carried out by the specialist dealer.

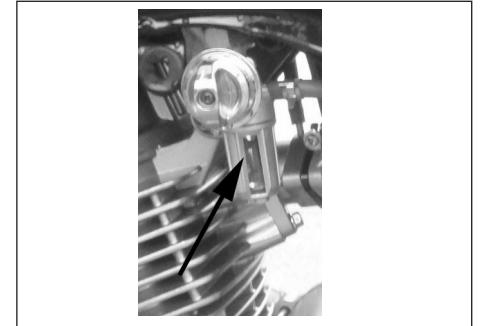

## AIR CLEANER

The air cleaner should be checked at regular intervals, especially if you ride the vehicle in very dusty and/or humid conditions.

The air cleaner is located on the left-hand side of the vehicle behind the side cover.

# PERIODIC MAINTENANCE AND MINOR REPAIR

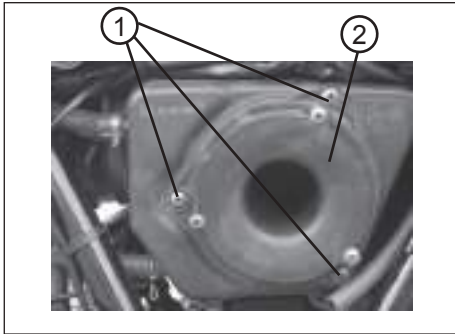

Remove screws (1), open cover (2). It is now possible to remove the air cleaner. The air cleaner should be cleaned dry or using only a specially formulated cleaning agent. If necessary, have the air cleaner exchanged by the specialist dealer.

## CAUTION

- Make sure that the air filter element is properly seated in the air filter case.
- The engine should never be operated without the air filter element installed, otherwise the piston and/or cylinder may become excessively worn.

## CARBURETOR

The carburetor is an important part of the engine and its emission control system, which requires very sophisticated adjustment. Therefore, carburetor adjustments should be left to dealer, who has the necessary professional knowledge and experience.

## CHECKING THE THROTTLE CABLE FREE PLAY

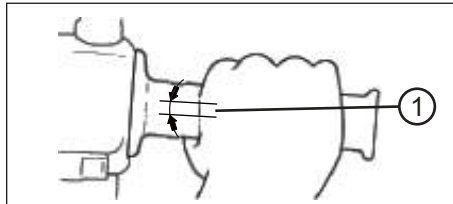

The throttle cable free play (1) should measure 1.5 ~ 3.5 mm at the throttle grip. Periodically check the throttle cable free play and, if necessary, have a dealer adjust it.

## CHECKING CLUTCH LEVER FREE PLAY

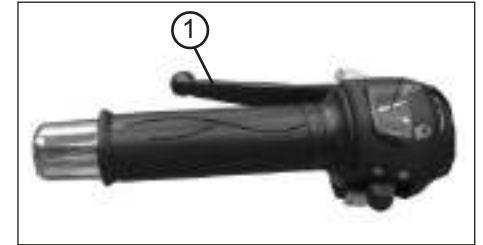

The clutch lever free play (1) should measure 1,0~2,0mm. Periodically check the clutch lever free play and if necessary, have a dealer adjust it.

## TIRES

To maximize the performance, durability, and safe operation of your vehicle, note the following points regarding the specified tires.

# PERIODIC MAINTENANCE AND MINOR REPAIR

## TIRE AIR PRESSURE

The tire air pressure should be checked and, if necessary, adjusted before each ride.

### ⚠ WARNING

The tire air pressure must be checked and adjusted on cold tires (i.e., when the temperature of the tires equals the ambient temperature).

#### Tire air pressure:

**Front: 2,1 bar - 2,5 bar**

**Rear: 2,1 bar - 2,5 bar**

Total weight of rider, passenger,  
cargo and accessories!

### ⚠ WARNING

The tire air pressure must be adjusted in accordance with the riding condition. If you are not familiar to this, please have dealer for help.

Do not over load your vehicle, since it will increase pressure on the tire, braking, steering than original design and

may could cause damage or even lead to accident.

Allocation of your cargo and weight of your vehicle is very important for your own safety and vehicle performance. Load your cargo rmlly on vehicle and put the heaviest cargo to the center of vehicle, then distribute the weight evenly from side to side. It will keep you to have good steering after load.

**Maximum load\*: 155 kg**

\* Total weight of rider, passenger,  
cargo and accessories

## TIRE INSPECTION

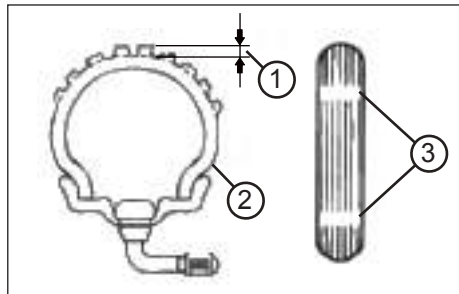

1. Tire tread depth
2. Tire sidewall
3. Tire wear indicator

### ⚠ WARNING

The tires must be checked before each ride. If a tire tread shows crosswise lines (minimum tread depth), if the tire has a nail or glass fragments in it, or if the sidewall is cracked, have a dealer replace the tire immediately.

### CAUTION

The tread depth may vary depending on country. Observe local regulations. The values listed here are technical values and may differ from the legal values of your region.

**Minimum tire tread depth:  
Front and rear: > 1,6 mm**

# PERIODIC MAINTENANCE AND MINOR REPAIR

## **⚠ WARNING**

- Drive with worn tire is illegal, reduces stability and can lead to loss of control over the vehicle.
- Let worn or damaged tires replaced immediately by your dealer.
- Working tires and the dealer is responsible.

### **DIMENSIONS TIRES/ RIMS**

**Front: Rim: 1,85 x 17  
Tire: 90/90-17**

**Rear: Rim: 2,50 x 17  
Tire: 110/80-17**

**Tyre type: tubless**

## **RIMS**

To maximize the performance, durability, and safe operation of your motorcycle, note the following points regarding the specified wheels.

- The wheel rims should be checked for cracks, bends or warpage before each ride. If any damage is found, have a dealer replace the wheel. Do not attempt even the smallest repair to the wheel. A deformed or cracked wheel must be replaced.
- The wheel should be balanced whenever either the tire or wheel has been changed or replaced. An unbalanced wheel can result in poor performance, adverse handling characteristics, and a shortened tire life.
- Ride at moderate speeds after changing a tire since the tire surface must first be “broken in” for it to develop its optimal characteristics..

## **CONTROLE THE BRAKE LEVER AND BRAKE PADEL FREE PLAY**

### Front brake

#### **CAUTION**

There should be no free play at the brake lever end. If there is free play, have a dealer inspect the brake system.

#### **⚠ WARNING**

A soft or spongy feeling in the brake lever can indicate the presence of air in the hydraulic system. If there is air in the hydraulic system, have a dealer bleed the system before operating the motorcycle. Air in the hydraulic system will diminish the braking performance, which may result in loss of control and an accident.

# PERIODIC MAINTENANCE AND MINOR REPAIR

## Rear brake

### CAUTION

Unlike the front brake lever needs to have the rear brake a game of about 10 mm. The rear brake is actuated cable. If there is no play, it may be that the brake linings drag permanently in the brake drum.

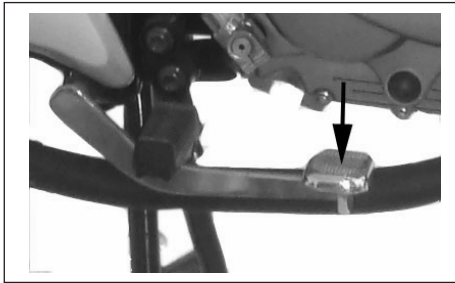

Periodically check the brake padel free play and, if necessary, adjust it as follows.

To increase the brake lever free play,

turn the adjusting nut at the brake shoe plate in direction (A). To decrease the brake lever free play, turn the adjusting nut in direction (B).

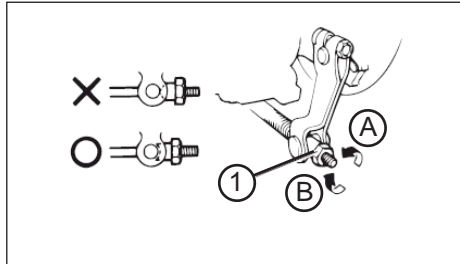

### WARNING

If proper adjustment cannot be obtained as described, have a dealer make this adjustment.

## BRAKE PADS

The front brake pads and the rear brake shoes must be checked for wear at the intervals specified in the periodic maintenance and lubrication chart.

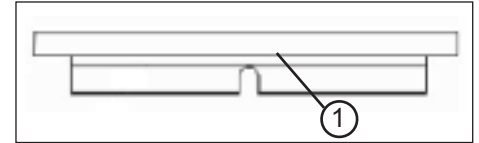

1. Wear indicator

## Front brake pads

Each front brake pad is provided with wear indicators, which allows you to check the brake pad wear without having to disassemble the brake. To check the brake pad wear, check the position of the wear indicators while applying the brake. If a brake pad has worn to the point that a wear indicator almost touches the brake disc, have a dealer replace the brake pads as a set.

## Rear brake Shoes

Always check and adjust the break lever before riding.

# PERIODIC MAINTENANCE AND MINOR REPAIR

To check the brake, check the position of the adjustable nut if the nut position reach to the end, have a dealer to replace the brake shoes as a set.

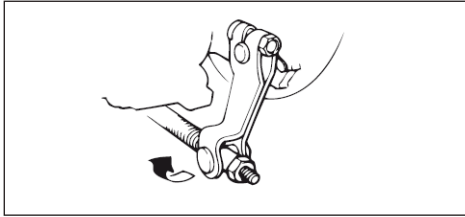

## BRAKE FLUID

### WARNING

Insufficient brake fluid may allow air to enter the brake system, possibly causing it to become ineffective. Before riding, check that the brake fluid is above the minimum level mark (1) and refill it if necessary.

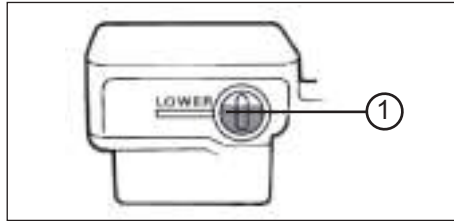

Low position brake fluid level may indicate worn brake pads and/or brake system leakage. If the brake fluid level is low, be sure to check the brake pads for wear and the brake system for leakage.

- When checking the fluid level, make sure that the top of the master cylinder is level by turning the handlebars.
- Use only the recommended quality brake fluid, otherwise the rubber seals may deteriorate, causing leakage and poor braking performance..

**Recommended brake fluid:  
Castrol Super Disc Brake Fluid DOT 4**

- Refill with the same type of brake fluid. Mixing fluids may result in a harmful chemical reaction and lead to poor braking performance.
- Be careful that water does not enter the master cylinder when refilling. Water will significantly lower the boiling point of the fluid and may result in vapor lock.
- Brake fluid may deteriorate painted surfaces or plastic parts. Always clean up spilled fluid immediately. As the brake pads wear, it is normal for the brake fluid level to gradually go down. However, if the brake fluid level goes down suddenly, have a dealer check.

# PERIODIC MAINTENANCE AND MINOR REPAIR

## CHANGING THE BRAKE FLUID

### WARNING

Have a dealer change the brake fluid at the intervals specified in the NOTE after the periodic maintenance and lubrication chart.

## CABLES

### Checking and lubricating

The operation of all control cables and the condition of the cables should be checked before each ride, and the cables and cable ends should be lubricated if necessary. If a cable is damaged or does not move smoothly, have a dealer check or replace it.

**Recommended lubricant:  
Castrol Motorrad DWF oilspray**

### WARNING

Damage to the outer housing of cables may result in internal rusting and cause interference with cable movement. Replace damaged cables as soon as possible to prevent unsafe conditions.

## THROTTLE GRIP AND CABLE

The operation of the throttle grip should be checked before each ride. In addition, the cable should be lubricated at the intervals specified in the periodic maintenance chart.

## LUBRICATING THE FRONT AND REAR BRAKE

The pivoting points of the front and rear brake must be lubricated at the intervals specified in the periodic maintenance and lubrication chart.

**Recommended lubricant:  
Castrol Motorrad DWF oilspray**

## FRONT FORK

### Checking the front fork

The condition and operation of the front fork must be checked as follows at the intervals specified in the periodic maintenance and lubrication chart.

**Recommended lubricant:  
Castrol Motorrad DWF oilspray**

### WARNING

Securely support the motorcycle so that there is no danger of it falling over.



# PERIODIC MAINTENANCE AND MINOR REPAIR

1. Place the vehicle flat and upright from.
2. Apply the front brake and push the handlebars several times down hard to verify the suspension of the fork..

## **⚠ WARNING**

- When damage to the fork, please contact your dealer.
- If you treat the telescopic fork with cleaning agents, make sure that they get no contact with the tires or the brakes. This can lead to dangerous accidents.

## **STEERING**

### Checking the steering

Worn or loose steering bearings may cause danger. Therefore, the operation of the steering must be checked as follows at the intervals specified in the periodic maintenance and lubrication chart.

1. Place the vehicle on the center stand/suitable motorcycle stand to raise the front wheel off the ground.
2. Hold the lower ends of the front fork legs and try to move them forward and backward. If any free play can be felt, have a dealer check or repair the steering.

## **WHEEL BEARINGS**

### Checking the wheel bearings

The front and rear wheel bearings must be checked at the intervals specified in the periodic maintenance and lubrication chart.

## **CAUTION**

If there is play in the wheel hub or if the wheel does not turn smoothly, have a dealer check the wheel bearings.

## **DRIVE CHAIN**

Please note that the drive chain must be checked regularly before every ride. Suitable care products are available from specialist dealers.

## **CAUTION**

An inadequately maintained and poorly tensioned chain accelerates the rate of wear of the chain itself, the chain drive and the output pinion.

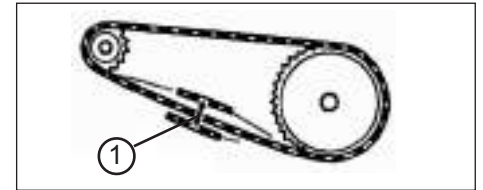

1. Free play (10mm ~ 20mm)

# PERIODIC MAINTENANCE AND MINOR REPAIR

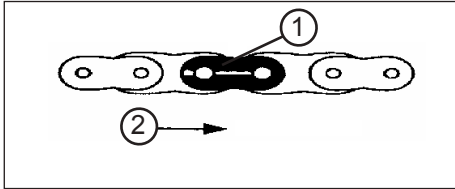

1. Chain lock
2. Direction

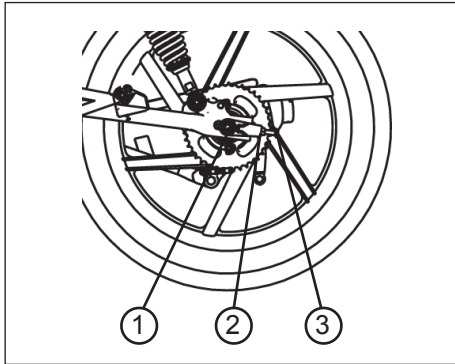

## TENSIONING THE DRIVE CHAIN

If you do not feel capable of completing this task on your own, please consult a specialist dealer.

1. Loosen the axle
2. Loosen the lock nut
3. Adjust the chain tensioner as required.

### CAUTION

After you have retensioned the chain, make sure that the rear wheel is in exact alignment with the front wheel, the lock nut is refastened and the axle is correctly secured.

## BATTERY

This model is equipped with a sealed-type (MF) battery, which does not require any maintenance. There is no need to check the electrolyte or to add distilled water.

### ⚠ WARNING

- Do not remove the battery vent seal, this can be dangerous, the battery permanently damaged.
- Battery acid is poisonous and dangerous, it contains sulfuric acid and leads to dangerous burns.
- Avoid skin, eye and clothing contact. Protect your eyes always when working near the battery.
- Upon contact with the battery acid, make immediate FIRST AID.

# PERIODIC MAINTENANCE AND MINOR REPAIR

- If skin or eye contact with battery acid, rinse the affected areas with plenty of water.
- When accidentally swallowed battery acid drink large amounts of water.
- In both cases, as soon as possible, see a doctor.
- Batteries develop explosive hydrogen gas. Keep open flames, smoking materials away from the battery and make sure there is adequate ventilation when you charge a battery indoors.
- **KEEP THIS AND ALL BATTERIES OUT OF THE REACH OF CHILDREN.**

## CHARGE THE BATTERY

Have a dealer charge the battery as soon as possible if it seems to have discharged. Keep in mind that the battery tends to discharge more quickly if the vehicle is equipped with optional electrical accessories.

## STORE THE BATTERY

- If the vehicle will not be used for more than one month, remove the battery, fully charge it, and then place it in a cool, dry place.
- If the battery will be stored for more than two months, check it at least once a month and fully charge it if necessary.
- Fully charge the battery before installation.
- After installation, make sure that the battery leads are properly connected to the battery terminals.

### WARNING

Please contact your dealer if you are not familiar with handling the battery.

### CAUTION

Always keep the battery charged. Storing a discharged battery can cause permanent battery damage.

## FUSE

The fuse holder is located behind battery cover.

## REPLACING THE FUSE

1. Turn the key to  and turn off all electrical circuits.
2. Remove the blown fuse, and then install a new fuse of the specified amperage.

**Specified fuse:  
15 Amp**

# PERIODIC MAINTENANCE AND MINOR REPAIR

## **⚠ WARNING**

Do not use a fuse of a higher amperage rating than recommended to avoid causing extensive damage to the electrical system and possibly a fire.

3. Turn the key to  and turn on the electrical circuits to check if the devices operate.
4. If the fuse immediately blows again, have a dealer check the electrical system.

## LIGHTING

### HEADLIGHT BULBS

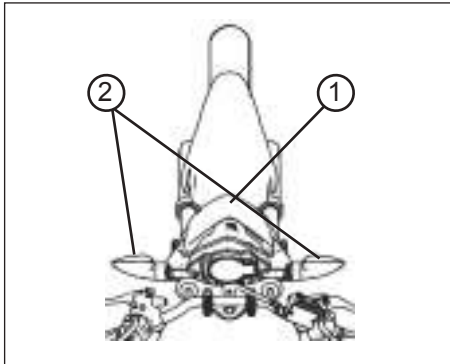

### CAUTION

This model is equipped with halogen bulb headlight (1). If a headlight bulb burns out, have a dealer replace it and, if necessary, adjust the headlight beam.

This model has furthermore a LED position light. If the LED position light defective, please contact your dealer.

### FRONT INDICATOR

If the turn signal light bulb does not come on, remove the screw of the indicator lens (2) out and replace the bulb.

### REAR INDICATOR

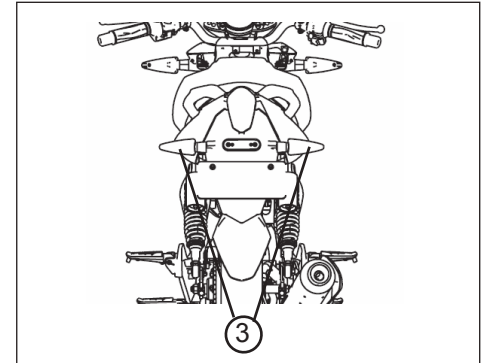

If the turn signal light bulb does not come on, remove the screw of the indicator lens (3) out and replace the bulb.

# PERIODIC MAINTENANCE AND MINOR REPAIR

## TAIL/BRAKE LIGHT AND LICENSE PLATE LIGHT

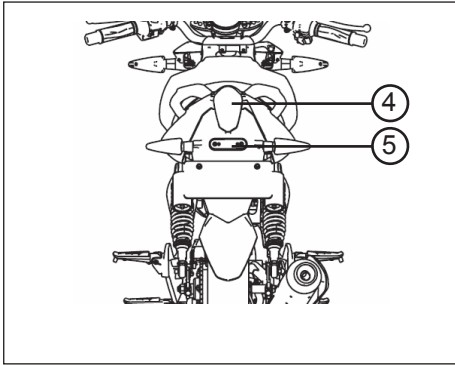

4. Tail/brake light
5. License plate light

If the tail/brake light and license light bulb does not come on, have a dealer check its electrical circuit or replace the bulb.

## TROUBLESHOOTING

Although the vehicles receive a thorough inspection before shipment from the factory, trouble may occur during operation. Any problem in the fuel, compression, or ignition systems, for example, can cause poor starting and loss of power.

The following troubleshooting chart represents a quick and easy procedure for checking these vital systems yourself. However, should your vehicle require any repair, take it to a dealer, whose skilled technicians have the necessary tools, experience, and knowhow to service the vehicle properly.

Use only genuine replacement parts. Imitation parts may look like parts, but they are often inferior have a shorter service life and can lead to expensive repair bills.

## TROUBLESHOOTING CHART

### ⚠️ WARNING

*Keep away from open flames and do not smoke while checking or working on the fuel system.*

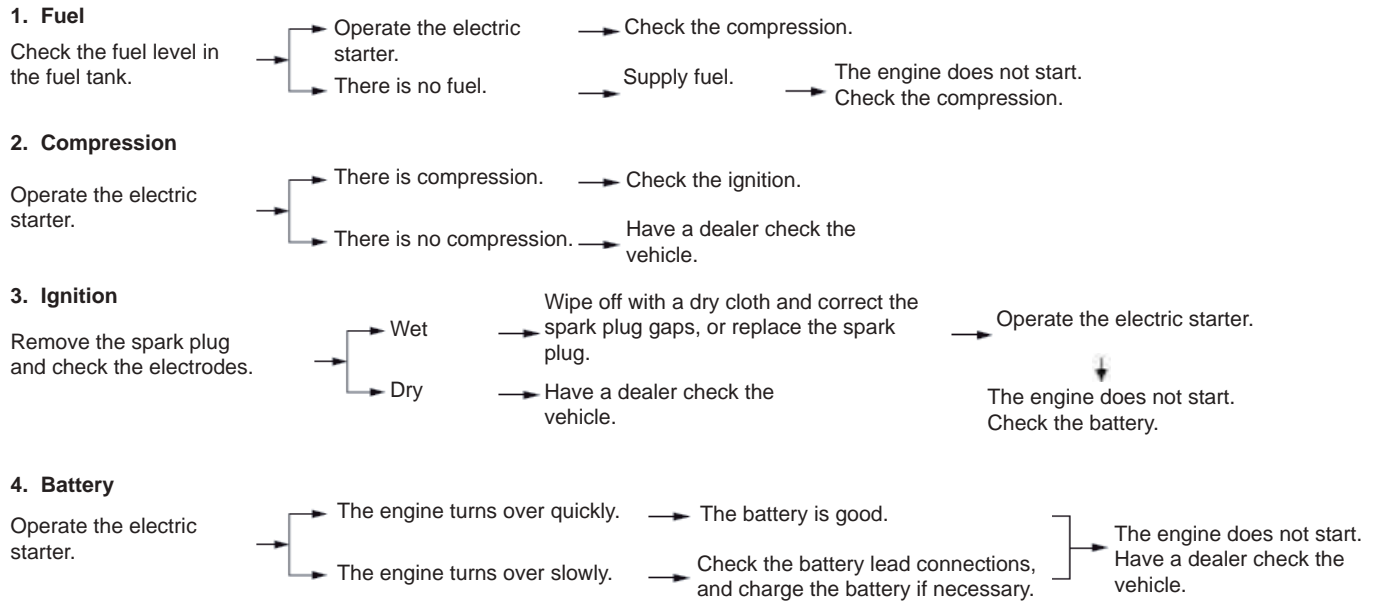

# CLEAN AND STORAGE

## CLEAN THE VEHICLE

Clean of the vehicle in proper and suitable way will make it attractive, extend it's life and optimize the performance.

## BEFORE CLEANING

1. Cover the muffler outlet with a plastic bag to prevent water to come inside. Please do it only after the
2. Closed every caps, covers, electrical connectors that are well install and water can be avoid to get into, while you do the clean job.

### CAUTION

- Do not use acid-based cleaners. If such funds used for stubborn stains, so use this only occasionally, dry it immediately after and then apply a corrosion protection spray.
- Always follow the manufacturer's instructions on care and cleaning agents.

- Use best only water and mild detergent or special cleaner from the dealer to the sensitive components of the vehicle to prevent damage. Dry the plastic parts then wipe with a soft, dry cloth or sponge.
- Protect particularly plastic parts, paint, headlight glass from harsh chemicals such as fuel, rust remover, brake cleaner or similar. The use of such agents may result in malfunction, damage and affect the security itself.
- Do not use a high pressure washer or steam cleaner, causing water in storage can penetrate electrical components such as connectors or switches, lighting, ventilation hoses, brake shoes and brake linings or damage, seals, paint and other surfaces.

## AFTER NORMAL USE

Remove dirt with warm water, a mild detergent, and a soft, clean sponge, and then rinse thoroughly with clean water. Use a toothbrush or bottlebrush for hard-to-reach areas.

## AFTER RIDING IN THE RAIN, SEAR THE SEA OR ON SALT-SPRAYED ROADS

### CAUTION

Since sea salt or salt sprayed on the roads during winter are extremely corrosive in combination with water, carry out the following steps after each ride.

- Wait until the engine / exhaust have cooled.
- Clean the vehicle with warm water and a mild detergent.
- Do not use hot water, which increases the corrosive effect of the salt.



# CARE AND STORAGE

- Apply a corrosion protection spray on all metal, including chrome- and nickel-plated, surfaces to prevent corrosion.

## AFTER CLEANING

- Dry the vehicle.
- To prevent rust, we recommend appropriate care to use according to manufacturer's instructions.
- Wax all painted surfaces.

### Recommended Castrol care products:

**Greentec Bike Cleaner**  
**Bike polish**  
**Motorcycle DWF oil spray**

### WARNING

- Make sure that there is no oil or wax on the brakes or tires. If necessary, clean the brake discs and brake linings with a regular brake disc cleaner and wash the tires with warm water and a mild detergent.
- Before operating the vehicle, test the braking performance and tires.

## STORAGE

### Short-term (for a few days)

- Always store your vehicle in a cool, dry place and, if necessary, protect it against dust with a vehicle cover.

### WARNING

Please store the vehicle in a well air flow room with dry air if possible. A place with wet humidity will cause rust.

### Long-term (for weeks)

- Clean the vehicle.
- Drain the fuel from the carburetor.
- Enter the drained fuel back into the fuel tank.
- Fill the fuel tank to completely or add if necessary a fuel stabilizer to protect the fuel tank from rusting and the fuel from degradation.

## CARE AND STORAGE

Follow the steps below to cylinders, piston rings, etc. to prevent rusting.

- Remove spark plug cap and the spark plug.
- Give a teaspoon of engine oil into the spark plug hole.
- Join the Kickstarter to slow down and let the engine several times slowly rotate (thus the cylinder is oiled).
- Put the spark plug back in and put on the spark plug cap.

### WARNING

To prevent damage or injury from sparking, make sure to ground the spark plug electrodes while turning the engine over.

- Lubricate all control cables and the pivoting points of all levers and pedals as well as of the side stand/main stand.
- Check and, if necessary, correct the tire air pressure, and then lift the vehicle so that both of its wheels are off the ground. Alternatively, turn the wheels a little every month in order to prevent the tires from becoming degraded in one spot.
- Cover the muffler outlet with a plastic bag to prevent moisture from entering it.
- Remove the battery and fully charge it. Store it in a cool, dry place and charge it once a month. Do not store the battery in an excessively cold or warm place [less than 0 °C (30 °F) or more than 30°C (90 °F)].

### CAUTION

Make any necessary repairs before storing the vehicle.

# SPECIFICATIONS

## DIMENSIONS

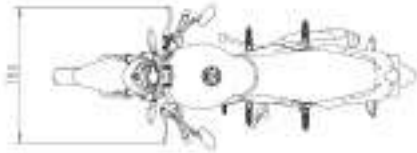
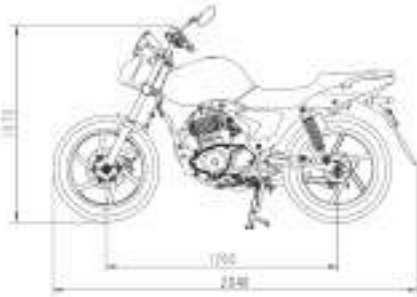

## ENGINE

Engine type  
Air cooled 4-stroke  
Cylinder arrangement  
Forward-inclined single cylinder  
Displacement  
125 cm<sup>3</sup>  
Compression ratio  
10.6:1  
Starting system  
Electric starter  
Lubrication system  
Separate lubrication  
4-stroke engine oil

## ENGINE OIL

Quantity: 1.2 L  
Recommended type  
Castrol Power 1 Racing 4T

## AIR FILTER

paper element

## FUEL

Unleaded gasoline only  
Capacity  
16 +/- 0.5l

## CAUTION

**!! BIOETHANOL FUEL -  
E10 IS NOT PERMITTED !!**

## CARBURETOR

Manufacturer  
EXACT

## SPARK PLUG

Manufacturer/model  
NHSP LD / B7RC  
NGK / DR8EA  
Spark plug gap  
0.6-0.7 mm

## CLUTCH

Clutch type  
Multiple plate clutch  
Transmission type  
5-speed constant mesh transmis-  
sion

## CHASSIS

Frame type  
Steel tube backbone

## FRONT TIRE

Rim: 1.85x17  
Tyre: 90/90-17

## REAR TIRE

Rim: 2.50x17  
Tyre: 110/80-17

# SPECIFICATIONS

## TIRE AIR PRESSURE (COLD TIRES)

Front: 2.1 bar - 2.5 bar

Rear: 2.1 bar - 2.5 bar

The selected tire pressure depends on the load!

## FRONT BRAKE

Type

Single Hydraulic disc brake

230mm

Operation

Right hand

## RECOMMENDED FLUID

DOT 4 - CASTROL Super Disc

Brake fluid DOT 4

## REAR BRAKE

Type

Mechanical Drum brake

130mm

Operation

Right feet

## FRONT SUSPENSION

Type

Telescopic fork

Spring/shock absorber type

Coil spring/oil damper

## REAR SUSPENSION

Type

Unit swing

Spring/shock absorber type

Coil spring/oil damper

## ELECTRICAL SYSTEM

Ignition system

CDI

Charging system

CDI magneto

## BATTERY

Model

12N7-4A

Voltage, capacity

12 V, 7.0 Ah

## HEADLIGHT

Halogen bulb

## BULB VOLTAGE, WATTAGE X QUANTITY

Headlight

12 V, 35 W/35.0 W

Tail/brake light

12 V, 5.0 W/21.0 W

Front turn signal light

12 V, 21.0 W

Rear turn signal light

12 V, 10.0 W

License plate light

12 V, 5.0 W

Meter lighting

12 V, 2 W

Meter lighting (fuel meter)

12 V, 2 W

High beam indicator light

12 V, 2 W

Oil level warning light

12 V, 3 W

Turn signal indicator light

12 V, 3 W

## FUSES

Main fuse

15.0 A

# CONSUMER INFORMATION

## IDENTIFICATION NUMBER

### VEHICLE - IDENTIFICATION NUMBER (VIN)

Please write down the VIN (vehicle identification number) to order replacement parts from your dealer or the vehicle should be stolen.

The vehicle identification number of the vehicle (1) is stamped on the steering head.

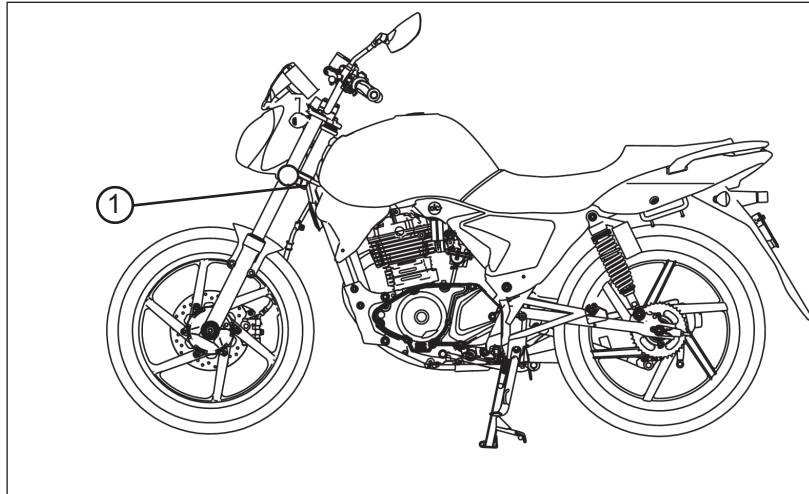

### CAUTION

The vehicle identification number is used to identify your motorcycle and may be used to register your vehicle with the licensing authority in your area.

# WARRANTY INFORMATION

Please carefully read the instruction manual of your vehicle before operating it in order to make yourself familiar with its handling. We explicitly point out that the instruction, maintenance, and care instructions given in the operating manual have to be complied with in order to sustain your claim towards warranty. Only the strict compliance with customer specifications stated in the instruction manual ensures the prolonging of the natural life of your vehicle. Starting with the date of the invoice a limited warranty of 24 months is granted regarding the accuracy of the vehicle in terms of material and manufacturing according to latest standards. The legal warranty regulations will not be restricted by this limited guarantee. Maintenance work has to be exclusively done by authorized workshops entitled by us. Warranty in general is bound to the region of invoicing and can therefore only be carried out within the country the vehicle was bought. Damages that can be traced back to inappropriate usage, manipulation, or neglecting of the maintenance/care/operating instructions will not be covered by warranty. Warranty can only be granted if occurring damages are immediately being reported to the seller or any other authorized workshop by the buyer. The warranty claim entitles the buyer to remedy deficiencies or to the reparation respectively the exchange of a damaged part in an authorized workshop after our approval. Compensation for remote or instantaneous damages cannot be granted. Vehicles in desolate condition will not be covered by warranty. Repair works carried out on warranty do not enlarge the guarantee period. Only this document entitles you to call on warranty services. Therefore please make sure that you are delivered this fully filled in document by the seller and that he has registered your vehicle correctly in our system. Please also mind the following advices.

Body and panelling of the vehicle have to be kept free of dirt constantly. Do not use high pressure water blasters, strong jets of water, sharp and corrosive or other aggressive detergents which could harm surfaces and varnish permanently and foster corrosion. It is vital to use protecting cleansers. Please consult our dealers for the right and appropriate products. Aluminium parts or other refined parts (chrome parts, anodized parts or other processed surfaces) have to be treated with appropriate maintenance products in order to prevent oxidation. Frame and metal parts are continuously to be treated with anticorrosive. A vehicle constantly parked outside has to be covered to avoid weathering and crack formations on seat and plastic parts. Vehicles used off-road and for racing purposes are excluded from warranty.

Material which is to be used in the context of service and maintenance works are excluded from warranty as well as the following parts: incandescent bulbs, brake pads, clutch lining, filter elements, spark plugs, drive sprocket, wheel and axle., as well as the tires.

# MAINTENANCE SCHEDULE

*The guarantee can be granted only if the vehicle has been serviced in accordance with this maintenance schedule.*

The inspection intervals are required, otherwise, no guarantee can be granted.		1000 km or 1. month	4.000 km or 6. month	7.000 km or 12. month	10.000 km or 18. month	13.000 km or 24. month
PART	TO DO					
Air filter	Clean/ exchange	√	√	Exchange	√	√
Wheels, rims	Control	√	√	√	√	√
Tires	Control/ tire pressure		√	√	√	√
Wheel bearing	Control/ exchange		√	√	√	√
Steering bearing	Control/ clean/ lubricate	√	√	√	Lubricate	√
Screws Coverparts	Control/ tighten		√	√	√	√
Brake system	Control/ clean/ exchange		√	√	√	√
Main stand	Control/ clean/ lubricate		√	√	√	√
Front forke	Control		√	√	√	√
Rear suspension	Control		√	√	√	√
Oil pump	Control	√	√	√	√	√
Transmission oil	Exchange	Exchange		Exchange		Exchange
Variomatic belt	Control/ exchange		√	Exchange	√	
Fly wheels	Control/ exchange		√	Exchange	√	
Driven chain/ sproket	Control/ clean/ exchange					
Clutch	Control	√	√	√	√	√
Cable/ bowden	Control/ clean/ lubricate	√	√	√	√	√
Throttle	Control/ clean/ lubricate		√	√	√	√
Lights/ switches	Control/ adjust	√	√	√	√	√
Fuel line/ fuel filter	Control/ exchange			Exchange		
Idle speed	Control/ adjust	√	√	√	√	√
Exhaust system	Control/ tighten		√	√	√	√
Coolant	Control					

**CAUTION:** Variomatic belt, fly wheels, spark pluge, fuel filter and air filter element have to be exchanged every 7000km. Only use duration coolant. Brake lines have to be exchanged at least every 4 years. From 13.000km or 24th month the inspection should be made every 7000km. The vehicle is constantly checked for rust. The owner is responsible for rust prevention.





# WIRING DIAGRAM

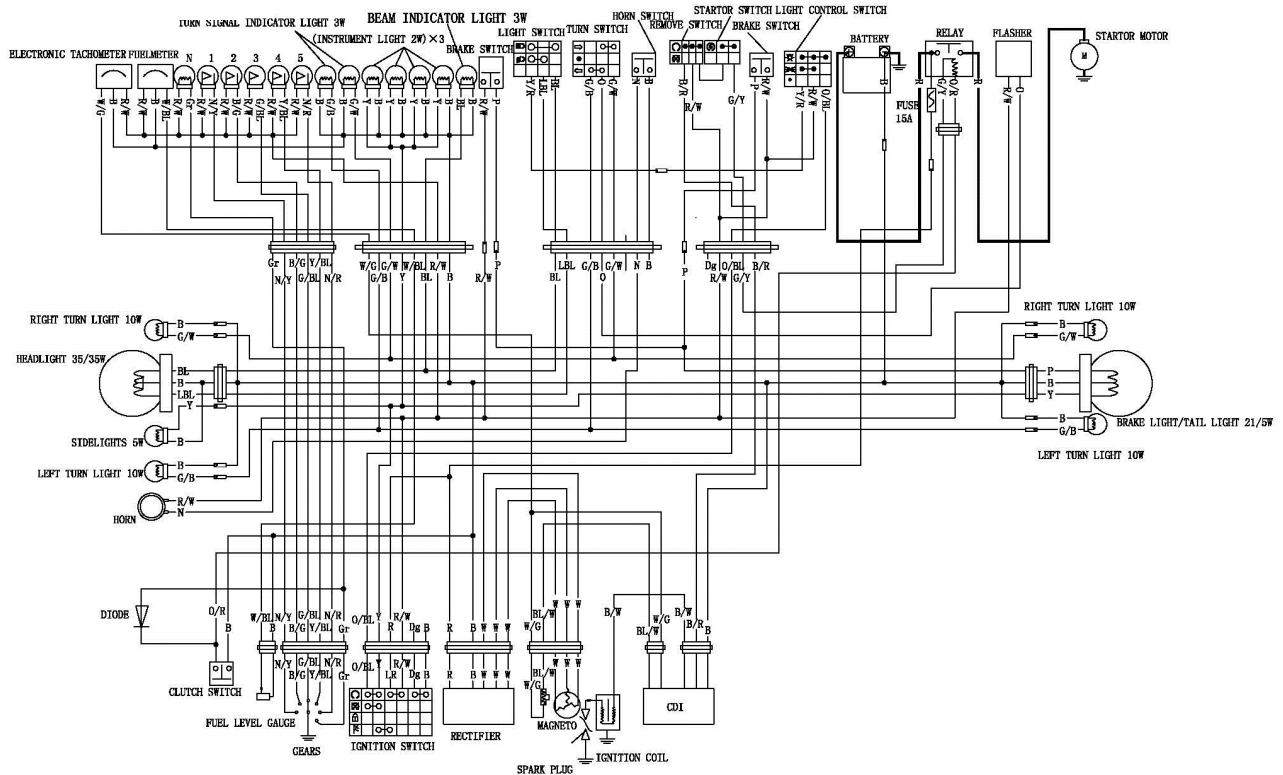

SYMBOL	B	R	W	BL	G	O	Y	P	N	LBL	Dg
COLOR	BLACK	RED	WHITE	BLUE	GREEN	ORANGE	YELLOW	PURPLE	BROWN	LIGHT BLUE	DARK GREEN

**SPACE FOR NOTES**

