



DOWNTOWN 300i OWNER'S MANUAL

**DO NOT REMOVE THIS OWNER'S MANUAL FROM THE VEHICLE.
READ THIS MANUAL CAREFULLY BEFORE OPERATING THE VEHICLE AS IT CONTAINS
IMPORTANT SAFETY INFORMATION.**

TABLE OF CONTENTS



SECTION 1 - SAFETY	1
IDENTIFICATION NUMBERS RECORD	3
FORWARD & SAFETY INFORMATION	4-5
SCOOTER SAFETY	6-7
LOAD LIMITS & LOADING GUIDELINES	8
ACCESSORIES & MODIFICATIONS	9

SECTION 2 – CONTROLS & FEATURES	10
LOCATION OF PARTS & CONTROLS	11-14
KEY & IGNITION SWITCH	15
SECURITY SHUTTER	16
INSTRUMENT CLUSTER	17-18
MULTIFUNCTION DISPLAY – DIGITAL CLOCK	19
RIGHT HANDLEBAR SWITCHES	20
LEFT HANDLEBAR SWITCHES	21
FUEL – INSPECTION, FILLING, RECOMMENDATIONS	22
SEAT & HELMET HOLDER	23
SUSPENSION	24

SECTION 3 - OPERATION	25
BREAK-IN RECOMMENDATIONS	26
TIRE BREAK-IN & TROUBLESHOOTING	27
PRE-RIDE INSPECTION (PRI)	28
STARTING THE ENGINE	29
RIDING YOUR SCOOTER	30-31
PARKING YOUR SCOOTER	32

SECTION 4 – MAINTENANCE	33
THE IMPORTANCE OF MAINTENANCE	34
MAINTENANCE SCHEDULE	35-36
ENGINE OIL	37-38
TRANSMISSION FLUID CHANGE	39
AIR FILTER MAINTENANCE	40
SPARK PLUG & BRAKE FLUID INSPECTION	41
COOLANT LEVEL INSPECTIONS & REPLACEMENT	42-43
SIDE STAND	44
BRAKE FLUID	45
BRAKE LEVER ADJUSTERS	46
BATTERY & FUSE	47
TIRES & TIRE PRESSURE	48
CLEANING YOUR SCOOTER	49-50
STORAGE GUIDE	51
MAINTENANCE RECORD	52
SPECIFICATIONS	53
EMMISSION CONTROL	54
WARRANTY INFORMATION	55



SECTION 1 - SAFETY

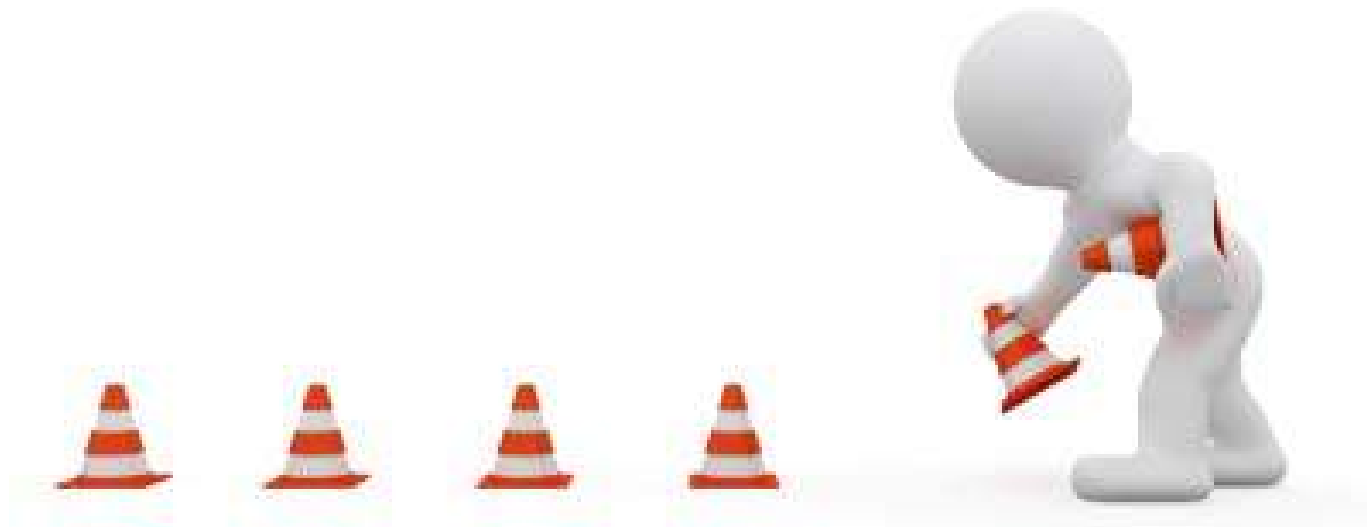

 **WARNING**

To avoid damage to the scooter's electronic fuel injection system, do not remove or install a battery wire when the ignition switch is at the "ON" position.

IDENTIFICATION NUMBERS RECORD

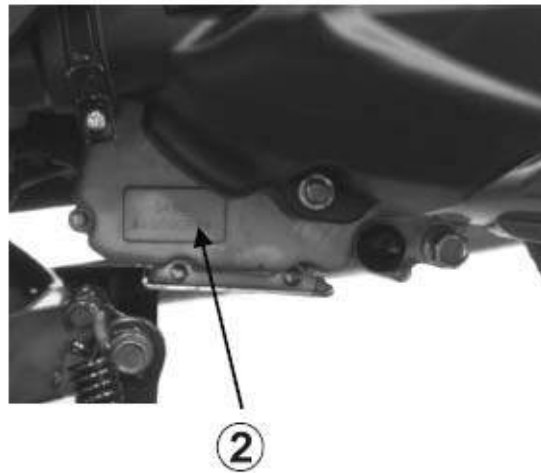

1. VEHICLE IDENTIFICATION NUMBER (VIN):

2. ENGINE SERIAL NUMBER (ESN):

3. FRAME SERIAL NUMBER (VIN):

Record the Vehicle Identification Number (1), Engine Serial Number (2), and Frame Serial Number (3) in the boxes above for future reference (to assist you in ordering parts from your local authorized KYMCO dealer or for reference in case vehicle is stolen).

This owner's manual contains important information on safety, operation and maintenance of your KYMCO Downtown 300i scooter. Anyone who operates your scooter should read and understand the contents of this manual before riding this scooter. For your safety, understand and follow ALL of the warnings contained in this Owner's Manual and the labels applied to your scooter. This Owner's Manual should be considered a permanent part of the vehicle, keep it with the scooter at all times.

ON ROAD USE ONLY!

This scooter has been designed to be used on the road.

Particularly important information is called out in this manual by the following icons and notations:

 **WARNING**

Failure to follow instructions associated with a **WARNING** symbol could result in severe injury or death to the rider, a passenger, a bystander, or a person inspecting or repairing the scooter.

 **CAUTION**

A **CAUTION** symbol indicates that special precautions must be taken to avoid damaging the scooter.

NOTE:

A **NOTE** symbol indicates key information about a procedure or to clarify an operation.

FORWARD & SAFETY INTRODUCTION



Thank you for purchasing this KYMCO Downtown 300i scooter, and welcome to the KYMCO riding family. Please read this owner's manual carefully before riding so that you will be thoroughly familiar with the proper operation of your scooter's controls, its features, its capabilities, and its limitations.

To ensure a long, trouble-free life for your scooter, provide it with the proper care and maintenance as described in this manual.

For replacement parts and accessories, you should always use genuine KYMCO products, as they have been specially designed for your vehicle and manufactured to meet KYMCO's demanding standards.

Keep this owner's manual aboard your scooter at all times, so that you can refer to it whenever you need information. This manual should be considered a permanent part of the scooter and should remain with the scooter when it is sold.

All information, illustrations, photographs and specifications contained in this manual are based on the latest product information available at the time of publication. Due to improvements or other changes, there may be information in this manual that differs slightly from your vehicle. KYMCO reserves the right to make product and publication changes at any time, without notice, and without incurring any obligation.



IMPORTANT SAFETY INFORMATION

Your scooter can provide you many years of service and pleasure if you take responsibility for your own safety and understand the challenges that you can meet on the road. There is much that you can do to protect yourself when you ride. You will find many helpful recommendations throughout this manual. Here are some very important safety tips:

Wear a helmet: Scooter safety equipment starts with a quality helmet. One of the most serious injuries you can suffer in a crash is a head injury. Always wear a properly approved helmet. You should also wear suitable eye protection.

Make yourself easy to see: To make yourself more visible, wear bright reflective clothing, position yourself so other drivers can see you, signal before turning or changing lanes, and use your horn when it will help others notice you.

Know your limits: Ride within the boundaries of your own skill at all times. Knowing these limits and staying within them will help you to avoid accidents. Always ride with both hands on the handlebars.

Keep your scooter in safe condition: For safe riding, it is important to inspect your scooter before every ride and perform all recommended maintenance. Never exceed load limits, and only use accessories that have been approved by KYMCO for this scooter.

Inspect your scooter before riding: Remember to perform an entire safety inspection to ensure you, and your passenger's safety, before each ride.

Be extra cautious on bad weather days: Riding on bad weather days, especially wet ones, requires extra caution. Braking distances can double on a rainy day. Stay off of the painted surfaces, manhole covers and greasy appearing areas on the pavement, as they can be especially slippery. Use extreme caution at railway crossings and on metal gratings and bridges. Whenever you are in doubt about the road conditions, slow down.

Modification: Modification of your scooter, or removal of original equipment may render the vehicle unsafe or illegal. Obey all applicable equipment regulations in your area.



PROTECTIVE APPAREL



For your safety, always wear an approved motorcycle or scooter helmet, eye protection, boots, gloves, long pants, and a long sleeved shirt or jacket whenever you ride your scooter.

Helmets and protection

Your helmet is your most important piece of riding gear because it offers the best protection against head injuries. Your helmet should fit your head comfortably and securely. Always wear a face shield or goggles to protect your eyes and to aid your vision.

Additional riding gear

In addition to a helmet and eye protection, you should also use:

-  Sturdy boots with nonslip soles to help protect your feet and ankles
-  Leather gloves to keep your hands warm and help prevent blisters, cuts, burns and bruises
-  A motorcycle or scooter riding suit or jacket that has been designed for comfort as well as protection. Bright colored and reflective clothing can help make you more noticeable in traffic. Be sure to avoid loose clothing that can get caught on any part of your scooter.

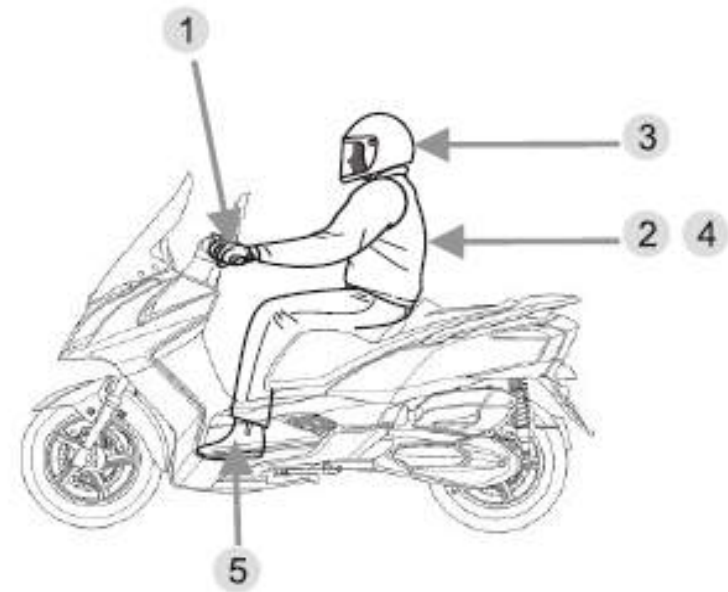

1. Wear gloves.
2. Clothes should fit properly (not too tight or loose).
3. Always wear a helmet. You should also wear eye protection.
4. Wear bright or reflective clothing.
5. Footwear should be the proper size, have low heels, and offer ankle protection

WARNING

Not wearing a helmet increases your chance of serious injury or death in a crash. Be sure you and your passenger always wear an approved motorcycle helmet that fits properly. You should also wear eye protection and other protective apparel when you ride.

LOAD LIMITS & LOADING GUIDELINES



These general guidelines may help you decide how to add accessories to your scooter and how to load it properly.

Load limits





These specifications are the load limits for your Downtown 300i scooter.

Overloading the scooter will affect its stability and handling, be sure to stay within the limits listed below:

- Maximum weight capacity (includes the weight of the rider, passenger, cargo and accessories):** 780 lbs (354 kg)
- Maximum cargo weight:** 582 lbs (264 kg)
- Rear carrier (rack) weight limit:** 55 lbs (25 kg)
- Under-seat compartment weight limit:** 22 lbs (10 kg)

Loading guidelines

Improperly loading your scooter will affect its stability and handling. You should ride at reduced speeds when you are carrying a passenger or cargo. Follow these guidelines whenever you carry a passenger or cargo:

-  Check that both tires are properly inflated
-  To prevent loose items from creating a hazard, make sure all cargo is securely tied down before you ride
-  Place cargo weight as close to the center of the scooter as possible
-  Balance cargo weight evenly on both sides of the scooter

WARNING

Overloading or improper loading will affect vehicle handling, stability and braking, and can lead to an accident. Never exceed the stated load capacity of your scooter.

Cargo should be properly distributed and securely attached. Reduce speed when carrying cargo and allow for more room for braking.

There is a large variety of accessories available to KYMCO scooter owners. KYMCO cannot have direct control over the quality or suitability of any accessories you may wish to purchase. The addition of unsuitable accessories to your scooter can lead to unsafe operating conditions. It is not possible for KYMCO to test each available accessory on the market or combinations of all such available accessories; however, your KYMCO dealer can assist you in the selection and installation of quality accessories.

Use extreme caution when selecting and installing the accessories for your scooter. No modifications.

KYMCO strongly advises you against removing any original equipment from, or modifying your scooter in any way that would change its design or operation.

 **WARNING**

Improper accessories or modifications can make your scooter unsafe and can lead to an accident.

Never modify your scooter through the improper installation or use of accessories. All parts and accessories added to this vehicle should be genuine KYMCO or equivalent components designed for use on this scooter and should be installed and used according to the accessory manufacturer's instructions. If you have any questions, consult an authorized KYMCO dealer.



SECTION 2 – CONTROLS & FEATURES



LOCATION OF PARTS & CONTROLS



1. Rear Brake Lever
2. Headlamp
3. Left Turn Signal Lamp
4. Side Stand
5. Seat
6. Air Filter
7. Taillight, Brake light
8. Coolant Reservoir

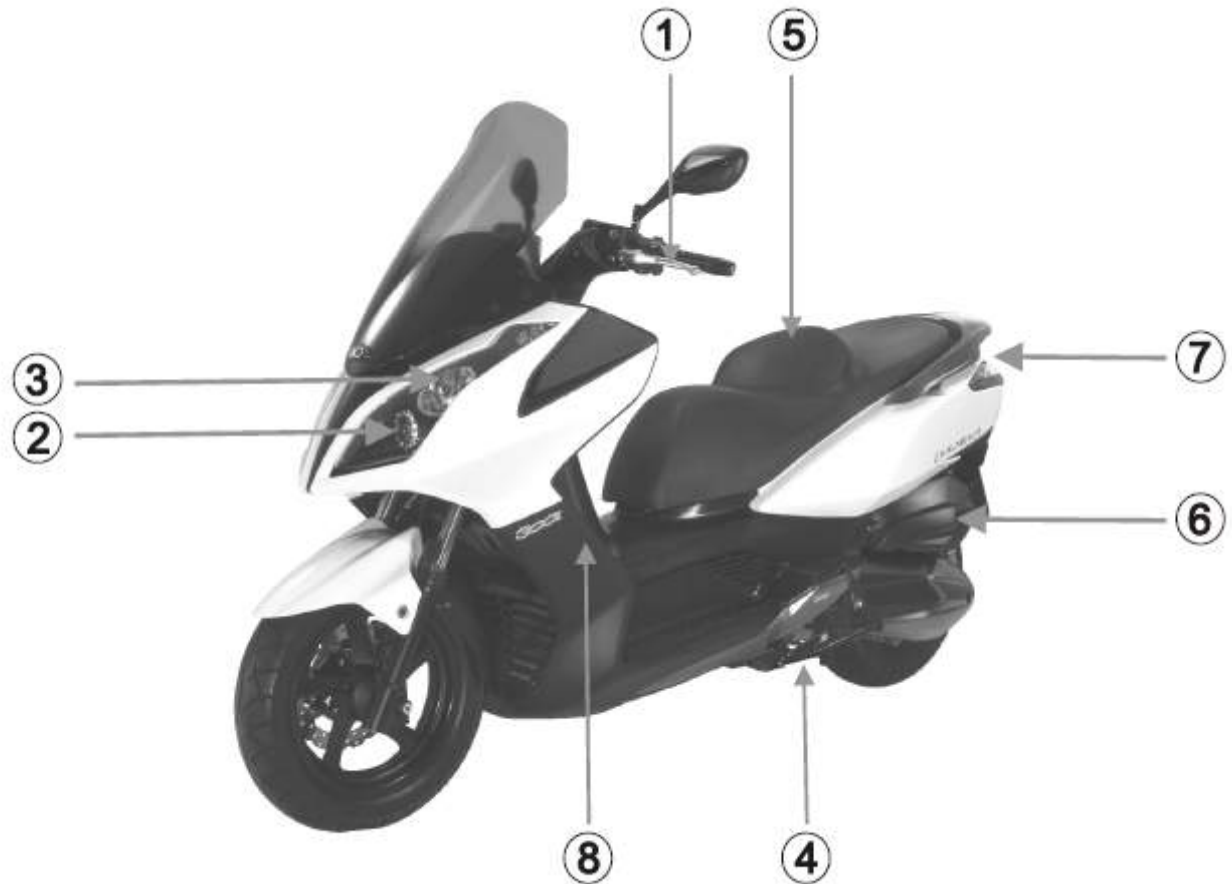

LOCATION OF PARTS & CONTROLS



- 9. Muffler
- 10. Oil Filler Cap / Dipstick
- 11. Fuel Filler Cap
- 12. Rear Passenger Foot Peg
- 13. Rear Turn Signal Light



- 14. Front Turn Signal Light
- 15. Headlight (Low Beam)
- 16. Headlight (High Beam)
- 17. Front Brake Lever

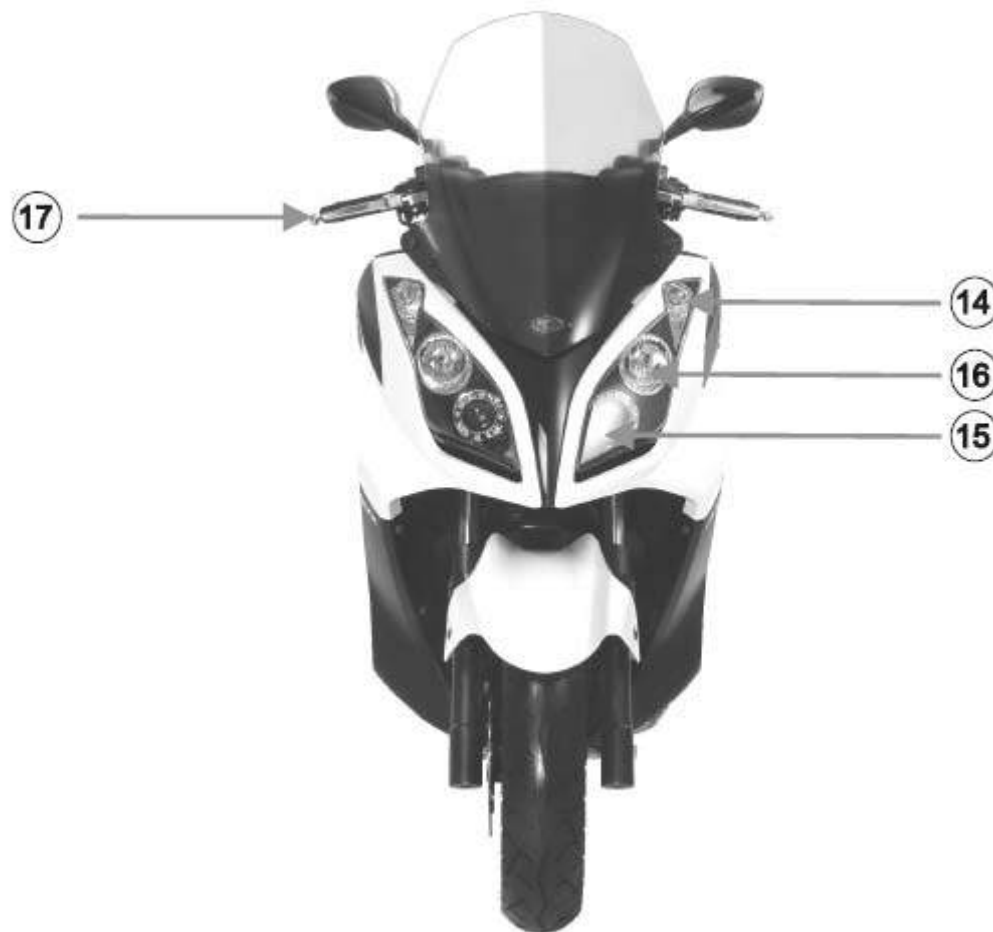

LOCATION OF PARTS & CONTROLS



- 18. Rear Turn Signal Light
- 19. Right Handlebar Switch
- 20. Ignition Switch
- 21. Output Voltage 12V
- 22. Battery and Fuses (under seat)
- 23. Windshield
- 24. Tail light / Brake Light

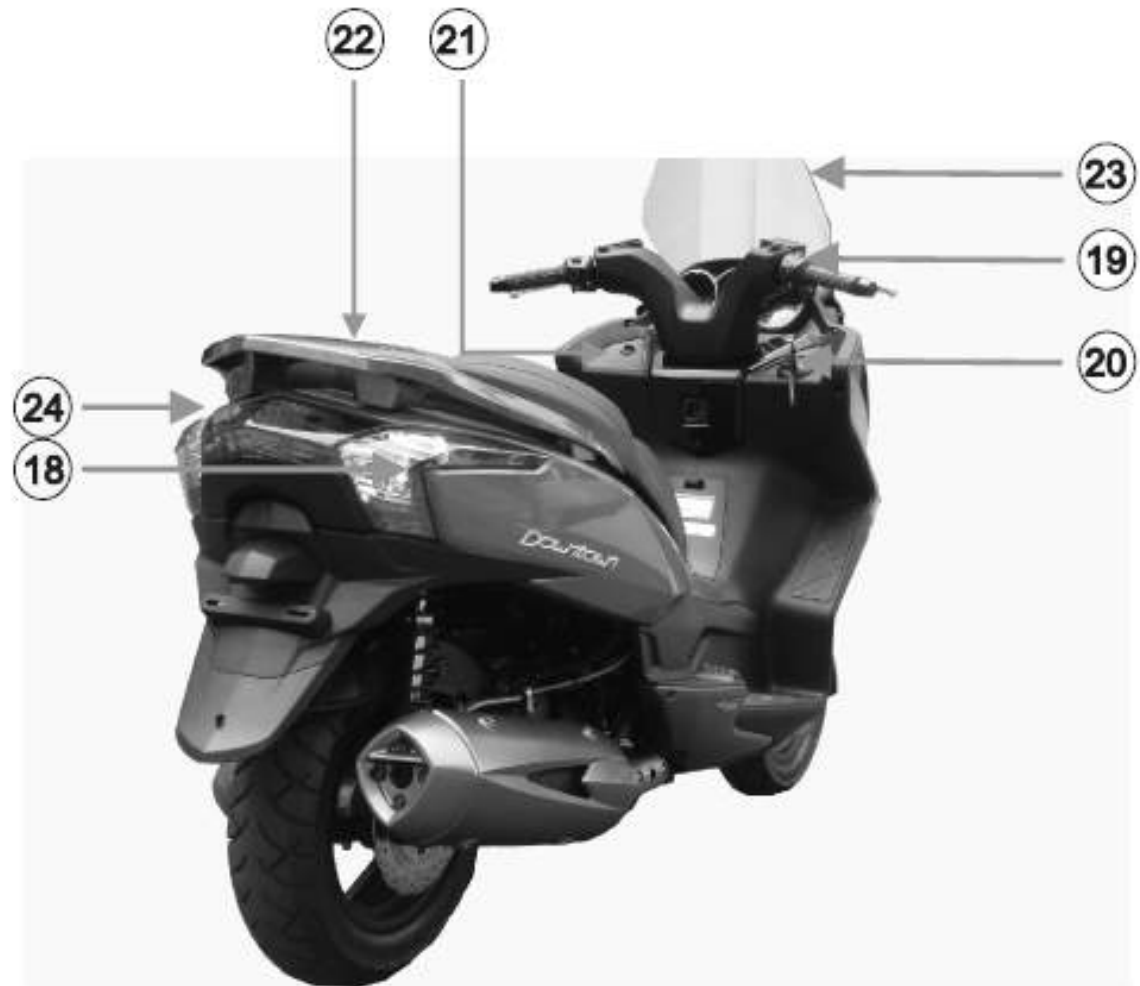

KEYS & IGNITION SWITCH



Keys

Your Downtown 300i scooter is supplied with two identical ignition switch keys. The ignition key operates the ignition switch, and the steering lock, and is used to open the seat to gain access to the under-seat storage compartment.

NOTE: The keys have a unique code stamped on the tab supplied with the keys. This code is not stamped on the scooter or recorded in the vehicle's basic documentation (for security reasons). Since this code is required to obtain replacement keys, record this important code in the box provided near the front of this Owner's Manual.

Ignition Switch

To operate the ignition switch and its functions:

OFF Position : All electrical circuits are off. The engine will not start or run.

ON Position : The ignition circuit is "ON" and engine can now be started. The key cannot be removed from the ignition switch in this position.

LOCK Position : To lock the steering, turn the handlebar all the way to the left, push in and turn the key to the LOCK position and remove the key. All electrical circuits are off.



SECURITY SHUTTER



Security Shutter

Push the “SHUT” button on the ignition switch cover and then the shutter (1) should be closed.

To shut the ignition switch security shutter:

Insert the specific key (2) until the fillister (3) is facing the pin.

Turn clockwise and then the security shutter should be opened.

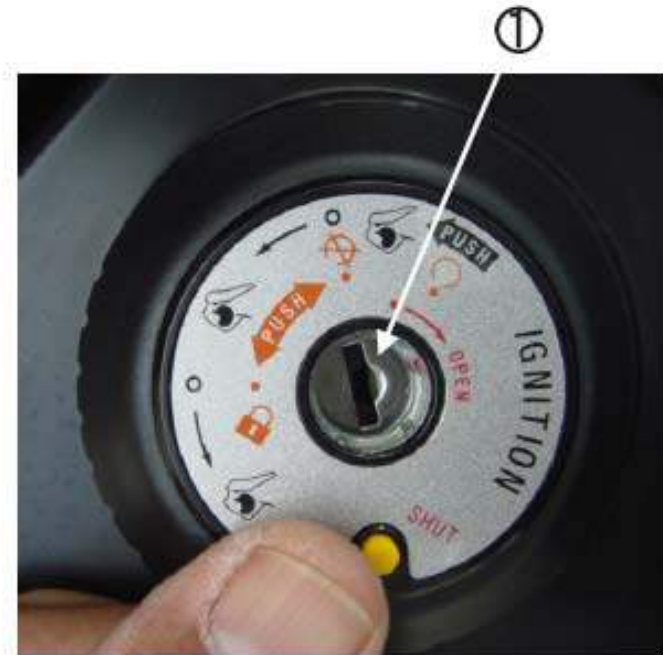

Instrument Cluster

- (1) **Odometer / Trip Meter:** Press the “MODE” button to toggle between the overall and trip mileage.
- Press the “ADJ” button for two seconds, which then display the ODO, TRIP (A,B), or SERVICE mode.
 - Press the “ADJ” and “MODE” button simultaneously at the TRIP mode to reset automatically.
- (2) **Speedometer:** Indicates the road speed in km/h.
- (3) **Turn Signal Indicator Light:** Flashes when either turn signal is being used.
- (4) **High Beam Indicator Light:** This light is illuminated when the headlight high beam is on.
- (5) **Fuel Refill Indicator** : This indicator lights when the fuel tank is near empty to alert the rider to refill the tank as soon as possible.
- (6) **Tachometer:** Indicates the engine speed in the revolutions per minute (RPM).
- (7) **Clock:** Digital clock display.
- (8) **Coolant Temperature Gauge:** Displays the coolant temperature.

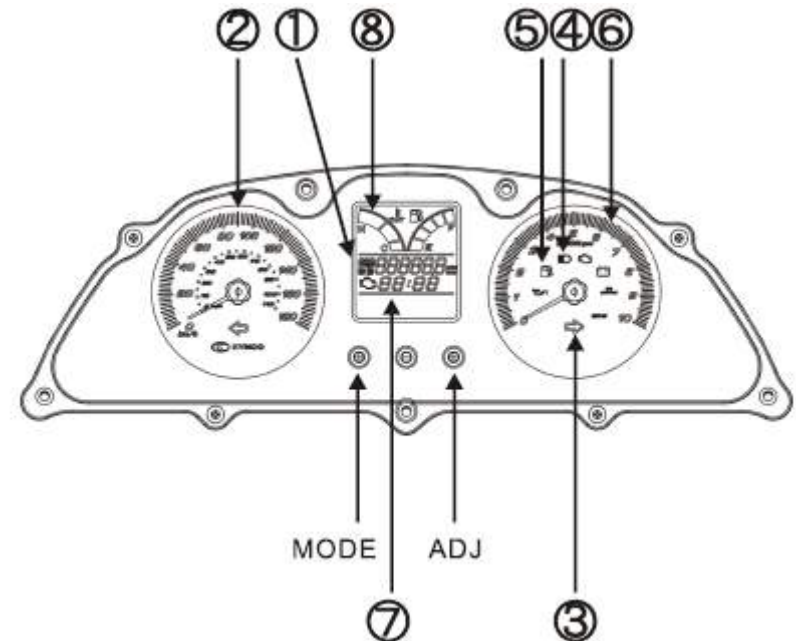

(9) **CELP Indicator:** If flashing, it indicates that a fault has been detected in the scooter's EFI or electrical system. Requires immediate inspection by your local authorized KYMCO dealer.

NOTE: The CELP indicator lights momentarily when the scooter is turned ON before the engine is running.

(10) **Oil Service Indicator:** Lights when the scooter has reached the oil service interval mileage. The indicator also lights when the ignition is turned ON but should go out once the engine is running.

- Press the ADJ and MODE button simultaneously at the SERVICE mode, then the indicator will go out automatically.

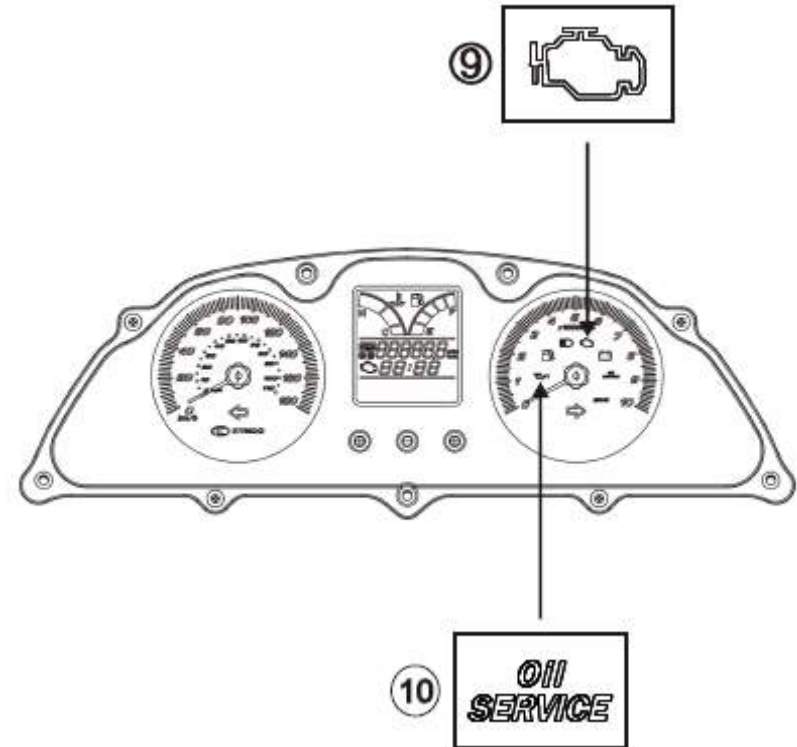

Multifunction Display – Digital Clock

The clock indicates the time in hours and minutes when the ignition is “ON”.

To adjust the clock’s time manually, follow this procedure:

1. Turn the ignition switch “ON”.
2. Press and hold the ADJUST button for more than two seconds to select the ODO mode.

NOTE: The digital clock can be only adjusted in ODO mode, don’t select the trip meter or oil service meter mode if you want to adjust the time on the clock.

3. Press and hold both the MODE button and ADJUST button at the same time for more than two seconds. The “hour” digits will begin flashing, indicating the clock time can be adjusted.



4. To set the hour display, press the ADJUST button until it displays the correct “hour” time.

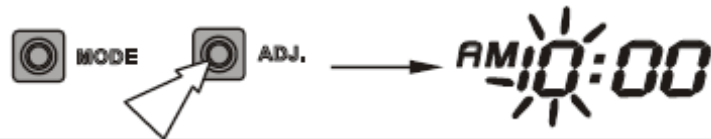

5. To change the minute display, press the MODE button until the “minute” digits begin flashing.

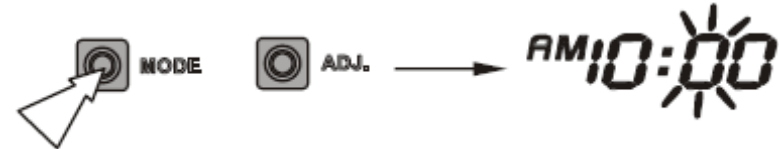

6. To set the minute display, press the ADJUST button until it displays the correct “minute” time.

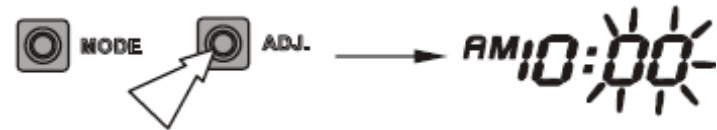

7. To end the clock adjustment, press both the MODE and ADJUST buttons at the same time. The display will stop flashing automatically. The adjustment will be cancelled if any button is not pressed within approximately ten seconds.

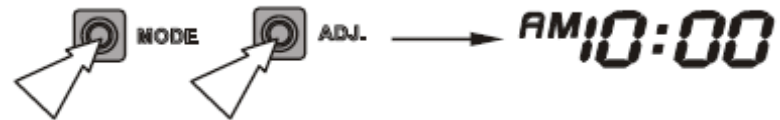

Right Handlebar Switches

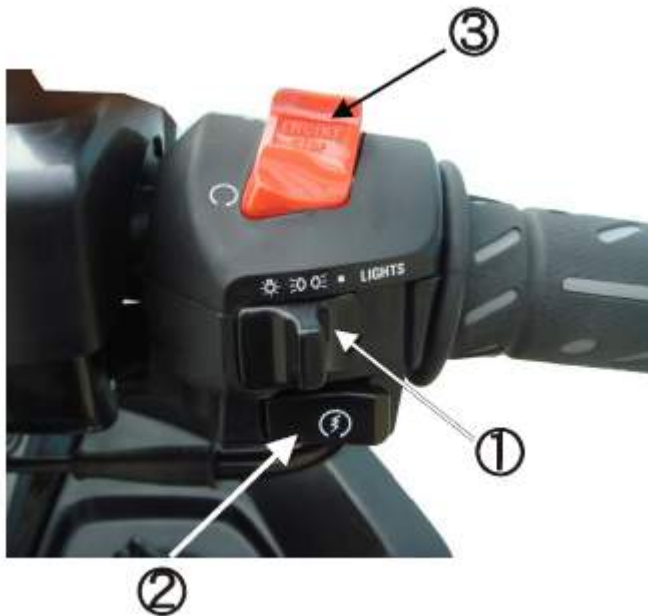

Headlight Switch (1)

- “☀️” position: The headlight and taillight will be lit.
- “☘️” position: The position light and taillight (running lamps) will be lit.
- “●” position: The headlight and taillight will be off.

Electric Starter Button (2)

- “⚡️” position: Press the electric starter button to activate the starter motor.

Engine Stop Switch (3)

- “⊗” position: The ignition circuit is off. The engine will not start or run.
- “⦿” position: The ignition circuit is on, and the engine can start and run.

NOTE: The starter motor will not engage unless a brake lever is squeezed at the same time the starter button is pressed. The Downtown 300i is also equipped with a safety interlock to prevent the starter motor from being engaged unless the side stand is fully up.

LEFT HANDLEBAR SWITCHES

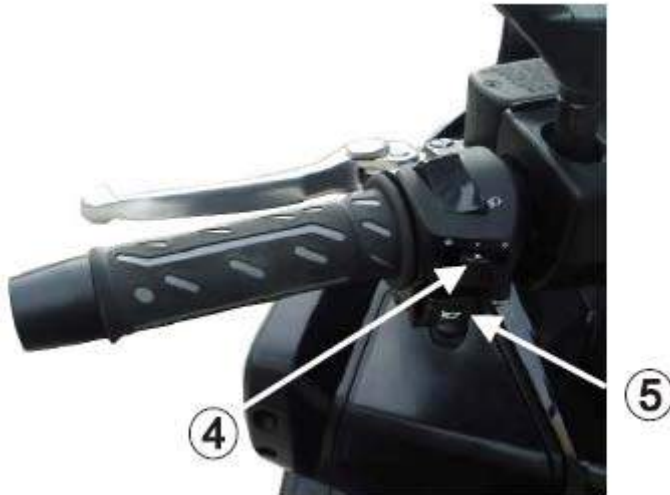

Turn signal switch (4)

Use the turn signal indicator to signal to other traffic your intention to turn or change lanes. The turn signal light on the dash will flash to alert the rider that the switch is engaged.

"←" for turning to the "left".
"→" for turning to the "right".

To cancel the turn signal, press in on the signal switch.

Horn button (5)

"📢" Press the horn button to sound the horn.

Dimmer switch (6)

"☀️" switch position turns the headlight high beam on and the high beam indicator light on the dash is activated as well.

"🌙" switch position turns the headlight low beam on.

Passing light button - PRESS DOWN (7):

Use this button to rapidly flick the head lamp high beam on and off to signal other vehicles that you wish to pass.

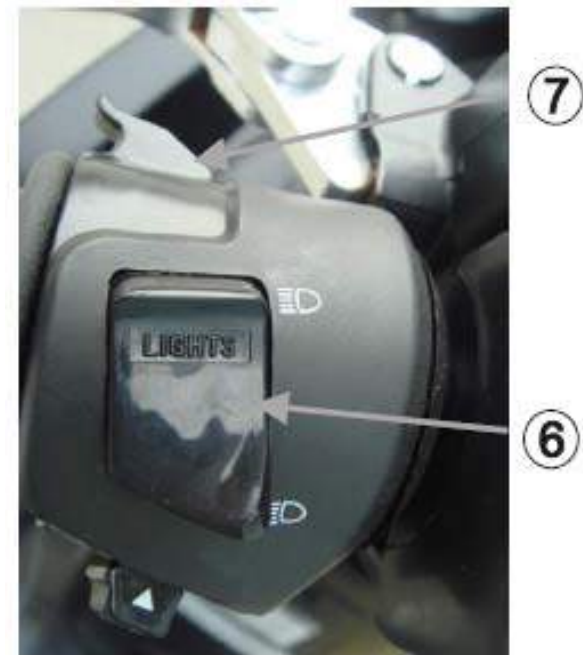

FUEL – INSPECTION, FILLING, RECOMMENDATIONS



Fuel level Inspection / Refilling

If the low fuel indicator on the dash begins to flash, refill the fuel tank with nonleaded gasoline as soon as possible.

Fuel Tank Filler

To add fuel to your scooter, follow this procedure:

1. Press and pull the fuel cap protective cover.
2. Use the ignition key to unlock the cap.
3. Turn the key clockwise to unlock the cap.
4. Once unlocked, lift the cap from the fuel filler neck.
5. To install the fuel filler cap, press it back into place on the fuel filler neck.
6. Rotate the key counterclockwise to lock the cap into place.
7. Remove the key and close the protective cover.

Fuel Recommendation

Use nonleaded gasoline with a research octane of number 91 or higher to prevent spark plug and exhaust component damage. After refueling, be sure to close the filler cap securely.



SEAT & HELMET HOLDER



Seat

To unlock the seat:

With the ignition key at the “🔑” position (the engine is running), push the key in and turn it counterclockwise from the “🔑” position to the “🔒” position.

With the ignition key in the “🔒” position (the engine is NOT running), turn the key counterclockwise from the “🔒” position to the “🔑” position.

Pull up on the back portion of the seat to lift up.

Helmet Holder

To use the helmet holders, open the seat and hook your helmet's fastener ring to the holder (8) and close the seat securely.



WARNING

Use the helmet holder only when your scooter is parked. Do not ride with a helmet hanging from the holder.

SUSPENSION



Each shock absorber (9) on your scooter has five spring loaded preload adjustment positions for different load or riding conditions.

Use a pin spanner (10) to adjust the rear shocks spring preload.

Position 1 is for light loads and smooth road conditions.

Position 3-5 increase spring preload for a stiffer rear suspension and can be used when the scooter is heavily loaded.

Be certain to adjust both shock absorbers to the same spring preload positions.

STANDARD SPRING PRELOAD POSITION: 3

CAUTION

Always adjust the shock absorber preload position in sequence (1-2-3-4-5 or 5-4-3-2-1). Attempting to adjust directly from 1 to 5 or 5 to 1 may damage the shock absorber.

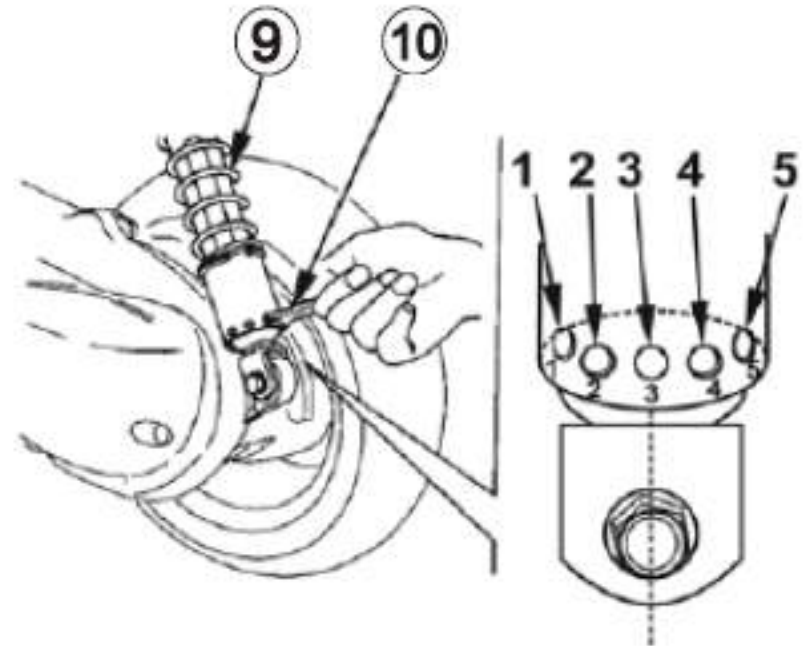



BREAK-IN RECOMMENDATIONS



Break-in recommendations

The first 600 miles (1,000 km) of riding are the most important in the life of your scooter. Proper break-in operation during this time will help ensure maximum life and performance from your new scooter. Proper break-in operation allows the machined surfaces to polish each other and mate smoothly.

Your scooter's reliability and performance depend on special care and restraint exercised during the break-in period. It is especially important that you avoid operating the engine in a manner which could expose the engine parts to excessive heat. The following guidelines should be followed during the break-in period:

Maximum throttle operation:

Initial 600km (300 miles): Less than 1/2 throttle

Up to 1000km (600 miles): Less than 3/4 throttle

Vary the engine speed: The engine speed should be varied and not held at a constant rate for long periods of time. This allows the parts to be "loaded" with pressure, and then unloaded, allowing the parts to cool. This aids in the mating process of the engine and transmission components. It is essential that some stress be placed on these components during break-in to ensure this mating process. Do not, however, apply excessive load on the scooter's drive line.

Avoid constant low speed: Operating the engine at constant low speed (light load) can cause parts to glaze and not seat in properly. Allow the engine to accelerate freely through the gears, without exceeding the recommended throttle openings. **Avoid using full throttle for the first 500 km (300 miles).**

The initial service: Observe your first and most critical service. The 300km (200 mile) initial service is the most important service your scooter will receive. During the break-in period all of the engine components will have worn in and all of the other parts will have seated in, so adjustments will be required. All fasteners will be tightened, and the contaminated engine oil will be replaced.

NOTE: Completion of the 300km (200 mile) initial service will ensure optimum service life and performance from your scooter. Do not delay in having this service performed once your scooter reaches this mileage.

CAUTION

The 200 mile (300 km) service should be performed as outlined in the maintenance schedule section of this owner's manual. Pay particular attention to the cautions and warnings in the maintenance schedule section. Unless you have formal training as a service technician and have access to KYMCO technical reference materials, it is strongly suggested that you have the initial service performed by a KYMCO dealer.

Breaking in the new tires

New tires need proper break-in to assure maximum performance, just as your scooter's engine does. Wear in the tread surface by gradually increasing your cornering lean angles over the first 160km (100 miles) before attempting maximum lean angles. Avoid hard acceleration, hard cornering, and hard braking for the first 160km (100 miles).



WARNING

Failure to break in your tires could cause the tires to slip and could result in you losing control of the scooter. Use extra care when riding on new tires. Perform proper break-in of the tires as described in this Owner's Manual and avoid hard acceleration, hard cornering, and hard braking for the first 160km (100 miles).

Troubleshooting

It can be frustrating if your scooter fails to start or stops running while you are riding. In the rare instance this happens, take a few moments to check some items and you may be back to riding your scooter soon.

- √ Do you have enough gasoline in the fuel tank?
- √ Did you follow the correct procedure for starting the engine?
- √ Is the battery voltage low (you may need to kick start your scooter)?
- √ Is the main fuse in good condition?

NOTE: Use this Owner's Manual to check components and adjustments that are within your technical ability. If you cannot resolve the problem, do not hesitate to contact your local authorized KYMCO dealer for assistance.

Pre-ride inspection (PRI)

For your safety, it is very important to take a few moments before each ride to walk around your scooter and check its condition. If you detect any problem, be sure to address it immediately, or have it corrected by your KYMCO dealer.

WARNING

Improperly maintaining your scooter or failing to correct a problem before riding can cause a crash in which you can be seriously hurt or killed.
Always perform a pre-ride inspection before every ride and correct any problems.

1. **Engine oil level:** Add engine oil if required (page 18). Check for leaks.
2. **Fuel level:** Fill fuel tank when necessary (page 22). Check for leaks.
3. **Front and rear brakes:** Check operation; make sure there is no brake fluid leakage (page 45).
4. **Tires:** Check condition and inflation pressure (page 48).
5. **Throttle:** Check for smooth operation and that it closes completely in all steering positions (page 40).
6. **Lights and horn:** Check that the headlight, tail / brake light, turn signals, indicators, and horn function properly.
7. **Steering:** Check for condition and smoothness.

CAUTION

Performing pre-ride inspections does not take the place of regular maintenance. Follow the maintenance schedule recommendations on pages 35-36 of this manual.
After one month of use or 300kms (200 miles) of riding, whichever occurs first, contact your local authorized KYMCO dealer to have an initial service of your scooter performed.
This initial service is the most important service in the life of your scooter, and includes checks and adjustments that will help ensure that your scooter operates efficiently and safely.



STARTING THE ENGINE



STARTING THE ENGINE

Always follow the proper starting procedure described here and on the following pages.

1. Place your scooter on its centre stand and put the side stand up.
2. Insert the ignition key and rotate the ignition switch to the “” ON position.
3. Squeeze the left (rear) brake lever.

NOTE: The electric starter will only work when the left (rear) or front (right) brake lever is squeezed.

4. With the throttle closed, press the starter button (1). Release the starter button as soon as the engine starts.
5. Keep the throttle closed while warming up the engine.
6. Let the engine warm up before riding.

CAUTION

To protect the catalytic converter in your scooter's exhaust system, avoid idling for extended periods of time and do not use leaded gasoline.

To prevent damage to the starter motor, do not operate the starter motor for more than five seconds at a time. If the scooter fails to start immediately, check the fuel level and battery condition, and allow the starter motor to cool before attempting to start the engine again.

Operating your scooter's engine with insufficient oil pressure can cause serious engine damage.



Riding your scooter

NOTE: After starting, allow the engine oil to circulate before riding your scooter. Allow sufficient idling time after warm or cold engine start-up before applying load or revving the engine. This allows time for the lubricating oil to reach all the critical engine components.

NOTE: Review the scooter safety recommendations on pages 2-4 before you ride.

1. Make sure the throttle is closed and the rear brake is engaged before moving the scooter off the main stand.
2. Mount the scooter from the left side and sit on the seat upright. Place both hands on the handlebars and touch the ground with your left foot for stability.
3. Release the rear brake and slowly rotate the throttle grip so the engine power will be transmitted to the rear wheel smoothly.
4. Control the scooter's speed with the throttle grip. Rotating the grip towards you will increase the scooter's speed. Rotating the grip away from you will decrease the scooter's speed.

NOTE: Decreasing the scooter's speed with a balanced application of both brake levers and a reduction of throttle will reduce the distance required to stop.

5. Limit the maximum speed of your scooter during the first 1,000 km (600 miles) of operation.
6. Use both brake levers when slowing and stopping the scooter. Release the throttle when braking.

NOTE: Decreasing the scooter's speed with a balanced application of both brake levers and a reduction of throttle will reduce the distance required to stop. Squeeze the levers lightly at first and then increase the pressure when stopping.

WARNING

Use the scooter's turn signals to signal your intention to merge into traffic. Always scan around you and in the rear view mirrors so you are aware of other traffic. Use caution as you merge into traffic, keeping to the right until you match the pace of the traffic.

CAUTION

In hot weather, the engine can overheat if it idles for a long period of time. Very slow speed traffic may also cause the scooter to overheat. To promote engine longevity, permit the engine to cool in these situations. Avoid sudden acceleration and prolonged high speed use that can accelerate engine wear. Moderate use will prolong the engine life of the scooter.

7. When riding and turning the scooter, use smooth movements.

NOTE: At certain speeds your scooter will turn more effectively by leaning your body, rather than by applying pressure on the handlebars. Practice steering in an open area that is free of traffic until you are familiar with the handling characteristics of your scooter.

8. As you approach a turn, or plan to stop, use the turn signals well in advance to alert other traffic of your intentions. Scan for other vehicles around you and slowly move to the right side of the road. Close the throttle and apply the brakes smoothly, as the scooter's brake light will alert vehicles behind you that you are braking.
9. When you stop the scooter, press the center of the turn signal indicator switch to cancel the signal flashing. Turn the ignition switch to the "OFF" position to stop the engine and turn off the scooter's electrical system.

 **WARNING**

Avoid using just one brake to stop the scooter, as this will affect the tire's grip. Avoid sudden braking, as this will also affect the tire's grip and can cause an accident.

 **WARNING**

Reduce your speed when riding on uneven or loose road surfaces. When riding downhill, decrease the throttle opening and use intermittent braking to control the vehicle's speed. Failure to take appropriate precautions may result in an accident.

 **WARNING**

Reduce your speed when riding your scooter in the rain. Wet road surfaces reduce tire grip and greatly increases the distance required for safe braking. Wet surfaces also reduces tire grip during cornering. Reduced tire grip will make it more difficult to control your scooter and may result in an accident.

 **WARNING**

Never operate the ignition switch while riding your scooter. If the ignition switch is turned during riding it could turn off the engine and lights, possibly causing you to lose control of the scooter. With the lights off, your scooter may not be visible to other traffic, and this could cause a traffic accident. Only operate the ignition switch when the scooter is not moving.

PARKING YOUR SCOOTER



Parking your scooter

Use the following procedure and suggestions when parking your scooter.

1. Place the scooter on level ground.
2. Stand on the left side of the scooter and grasp the handlebar with your left hand while grasping the side of the rear rack with your right hand. Step down on the foot pad of the main stand with your foot while pulling up and back on the rear rack. This lifting motion will allow the scooter to rock backwards and up onto the main stand.

CAUTION

The scooter may fall over if it is not parked on level ground. Make sure flammable materials such as dry grass or leaves do not come in contact with the exhaust system when parking your scooter.

Lock the handlebars of your scooter (see page 9) to reduce the risk of theft.

WARNING

Do not park your scooter in a place that hinders traffic, or that is unsafe to you or others.

SECTION 4 - MAINTENANCE



The importance of maintenance

Maintaining your scooter properly is essential for safe, economical and trouble-free riding. It will also help reduce air pollution and maximize fuel economy.

To help you properly care for your scooter, the following pages in this Owner's Manual include a maintenance schedule to help you make sure your scooter is serviced at the appropriate intervals.

These instructions are based on the assumption that your scooter will be used exclusively for its designed purpose. Sustained high speed operation, or operation in unusually wet or dusty conditions, will require more frequent service than specified in the maintenance schedule. Consult your local authorized KYMCO dealer for recommendations applicable to your individual needs and use.

NOTE: Always follow the inspection and maintenance recommendations and schedules in this Owner's Manual.

WARNING

If your scooter tips over or becomes involved in a crash, be sure your local authorized KYMCO dealer inspects all major parts, even if you are able to make some repairs.

Improperly maintaining this scooter or failing to correct a problem before you ride could result in a crash in which you could be seriously hurt or killed.

When performing maintenance on your scooter, you may need to start the engine. Running your scooter's engine indoors or in a garage can be hazardous. Exhaust gas contains carbon monoxide, a colorless and odourless gas that can cause death or severe injury. Operate the engine only where there is adequate ventilation, preferably outdoors.



Maintenance schedule

Perform the pre-ride inspection (see page 28) at each scheduled maintenance period. This interval should be judged by odometer reading or months, whichever comes first.

Maintenance schedule legend (see page 36):

I: INSPECT AND CLEAN, ADJUST, LUBRICATE OR REPLACE IF NECESSARY

C: CLEAN

R: REPLACE

A: ADJUST

L: LUBRICATE

T: TIGHTEN

The maintenance schedule on **page 36** specifies the maintenance required to keep your Super 8 scooter in peak operating condition. Maintenance work should be performed in accordance with KYMCO standards and specifications by properly trained and equipped technicians. Your local authorized KYMCO dealer meets all of these requirements.

* Should be serviced by your local authorized KYMCO dealer, unless you have the proper tools, service data and are technically qualified.

* * In the interest of safety, we recommend these items be serviced only by your local authorized KYMCO dealer. KYMCO Canada recommends that your local authorized KYMCO dealer does a road test with your scooter after each periodic maintenance service is completed.

MAINTENANCE SCHEDULE – DOWNTOWN 300i



ITEM	FREQUENCY	WHICHEVER COMES FIRST ↓	ODOMETER READING							REFER TO PAGE	
			X 1000 KM	1	5	10	15	20	25		30
			X 1000 MI	0.6	3	6	9	12	15		18
			MONTH	1	6	12	18	24	30		36
* Air Cleaner				R	R	R	R	R	R	33	
Spark Plugs				I	R	I	R	I	R	34	
* Throttle Operation				I	I	I	I	I	I	33	
* Valve Clearance				I	A	I	A	I	A	-	
* Fuel Line					I		I		I	-	
Crankcase Breather				C	C	C	C	C	C	-	
* Engine Oil				R	R	R	R	R	R	29	
* Engine Oil Screen				C	R	C	R	C	R	-	
* Engine Oil Filter				R	R	R	R	R	R	-	
* Engine Idle Speed					I		I		I	-	
* Transmission Oil				R	R	R	R	R	R	32	
* Drive Belt				I	I	I	R	I	I	-	
** Clutch Shoe Wear					I		I		I	-	
Brake Fluid				I	R	I	R	I	R	38	
Brake Pad Wear				I	I	I	I	I	I	40	
Brake System				I	I	I	I	I	I	-	
* Brake Light Switch				I	I	I	I	I	I	-	
** Steering Bearings				I	I	I	I	I	I	-	
* Headlight Aim				I	I	I	I	I	I	-	
* Nuts/Bolts/Fasteners				I	I	I	I	I	I	-	
** Wheels / Tires				I	I	I	I	I	I	42	
** Coolant				I	R	I	R	I	R	35	

ENGINE OIL



Engine Oil

Engine oil recommendation:

Use a premium quality 4-stroke engine oil to ensure longer service life of your scooter. Only use oils that have a SJ rating per the API service classification.

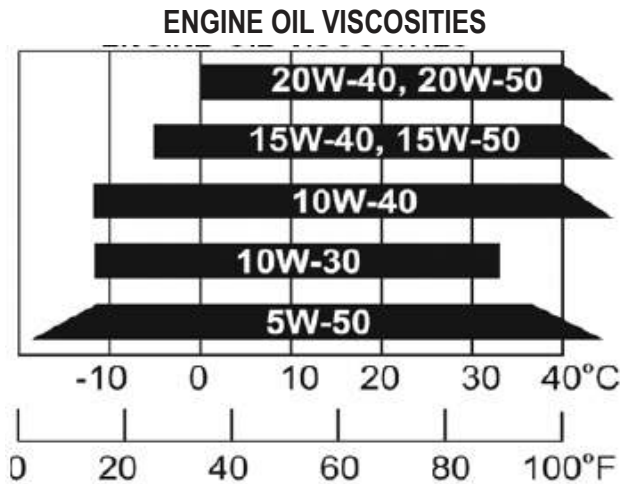

Engine Oil Capacity: 1.5 L

Engine Oil Level Inspection

Check the engine oil level each day before riding your scooter. The level must be maintained between the upper (1) and lower level (2) marks on the oil filler cap / dipstick (3).

NOTE: Change the engine oil with the engine at normal operating temperature with the scooter positioned on its main stand to assure complete and rapid draining.



1. Start the engine and let it idle for a few minutes.
2. Stop the engine and put the scooter on its centre stand on level ground.
3. After a few minutes, remove the oil filler cap / dipstick, wipe it clean, and reinsert the oil filler cap / dipstick without screwing it in. Remove the oil filler cap / dipstick. The oil level should be between the upper and lower marks on the oil filler cap / dipstick.
4. If required, add the specified oil so that the oil level touches the upper level mark on the dipstick. Do not overfill.
5. Reinstall the oil filler cap / dipstick (3). Check for oil leaks.

WARNING

The engine and related components can become very hot. Use care when inspecting the oil level so that you do not burn yourself. If needed, let the engine and exhaust system cool before working in those areas.

Engine Oil Replacement

Engine oil quality is the primary factor affecting engine longevity. Change your scooter's engine oil as specified in the maintenance schedule (see page 36).

NOTE: Change the engine oil with the engine at normal operating temperature and the scooter on its centre stand to insure complete and rapid draining.

1. Remove the oil filler cap / dipstick (3) from the right crankcase cover.
2. Place a suitable container (drain pan) under the left crank case.
3. Remove the oil drain plug (4) from the crankcase to drain the oil.
4. Reinstall the drain plug and tighten it to the specified torque.
5. Add oil to the engine per the amounts listed below, and reinstall the oil filler cap / dipstick.

Engine Oil Capacity: 1.5 L

Engine Oil Exchanging Capacity: 1.3 L

NOTE: Amounts are after draining the oil only.

6. Start the engine and let it idle for 2-3 minutes.
7. Stop the engine and check the oil level on the dipstick when the scooter is parked on the centre stand on level ground.
8. Adjust the oil level as required (so that the level reaches the upper mark on the dipstick). Replace the dipstick and inspect for any leaks.

 **CAUTION**

Running the engine with insufficient oil pressure can cause serious engine damage.

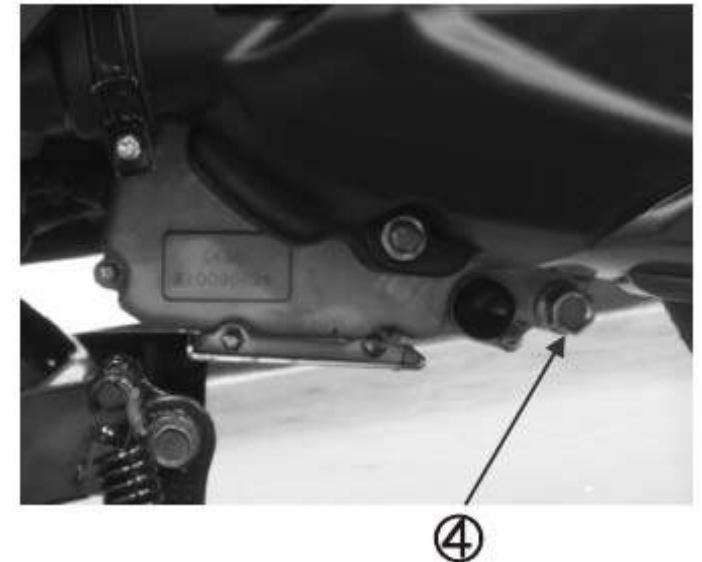

TRANSMISSION FLUID CHANGE



Transmission Fluid Change

1. Place the scooter on its centre stand.
2. Remove the transmission fluid drain bolt (1).
3. Remove the transmission fluid filler bolt (2), then slowly rotate the rear wheel to drain the fluid.
4. Fill the transmission with the recommended fluid to the capacity listed below.

Transmission Fluid Type:	SAE 90
Transmission Fluid Capacity:	0.23 L
Transmission Fluid Exchanging Capacity:	0.21 L

5. Install the transmission filler bolt and tighten it to the specified torque.



AIR FILTER MAINTENANCE



Air cleaner filter element

The air cleaner filter element (1) should be serviced at regular intervals by an authorized KYMCO dealer, unless you have the proper tools, service data and are technically qualified to do so. Service the element more often when riding in unusually wet or dusty areas.

CAUTION

Using the wrong KYMCO air cleaner element or a non-KYMCO air cleaner element which is not of equivalent quality may cause premature engine wear or performance problems.



①

Throttle Operation

1. Before each ride, check for smooth throttle grip rotation from the fully open to the fully closed position at both full steering positions.
2. Measure the throttle grip free play at the throttle grip flange (per the illustration to the right)

Throttle free play:

0.08 – 0.24 in (2.0 – 6.0 mm)

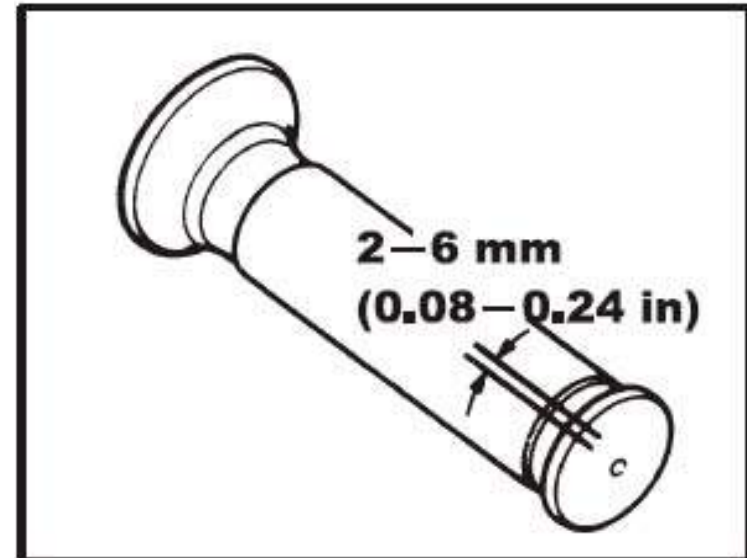

Spark plug

Remove the carbon deposits from the spark plug with a small wire brush or a spark plug cleaning machine. After cleaning (or when installing a new spark plug) readjust the spark plug gap to specified limit by using a spark plug gap thickness gauge. The spark plug should be replaced periodically.

Whenever removing the carbon deposits, be sure to observe the colour of the removed spark plug's porcelain tip. This colour tells you whether or not the standard spark plug is suitable for your type of riding. Under normal usage, a spark plug's porcelain tip should appear light brown or tan in colour.

If the spark plug porcelain tip is very white or glazed appearing, then the spark plug has been operating too hot. In such a situation, you should replace the standard spark plug with a spark plug that has a colder heat range (usually a higher number; consult with your local authorized KYMCO dealer when selecting an alternate spark plug).

Recommended spark plug

Spark plug type:

CR7E (NGK)

Spark plug gap:

0.024 - 0.028 in (0.6 - 0.7 mm)

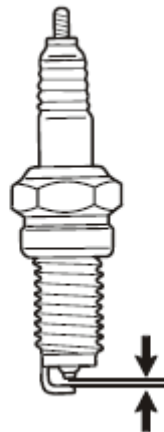
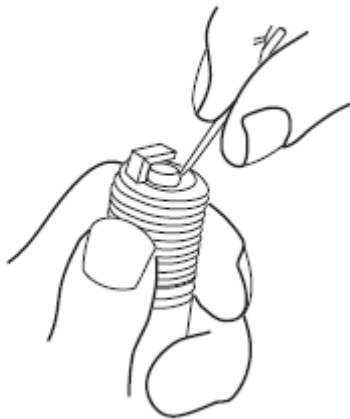

CAUTION

An improper spark plug may have an incorrect fit or heat range for your engine. This may cause severe engine damage which will not be covered under warranty. Never use a spark plug with an improper heat range, as severe engine damage may result.

COOLANT LEVEL INSPECTIONS & REPLACEMENT



Coolant Level Inspection

The reserve tank is under the left floorboard. Check the coolant level through the inspection window (1) at the left side skirt while the engine is at normal operating temperature and the scooter in an upright, level position.

If the coolant level is below the LOWER level mark (3), remove the floor mat, remove the lid screw (4), the reserve tank lid (5), and then the reserve tank cap (6) to add coolant to the mixture until it reaches the upper level mark (2).

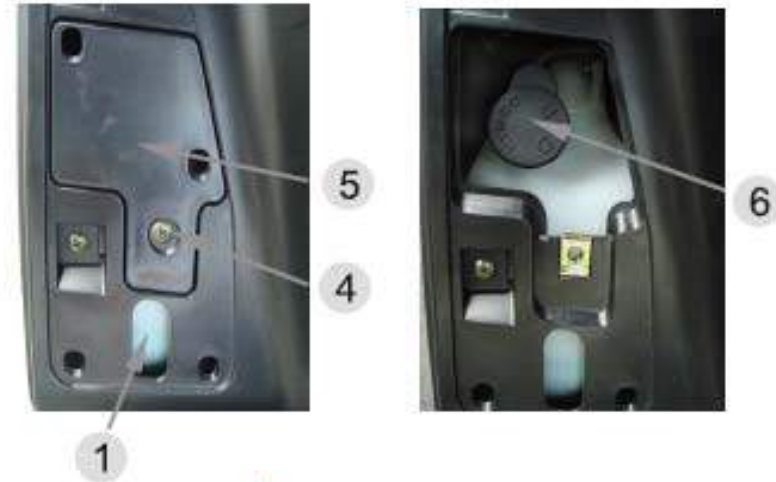

WARNING

Add coolant to the reserve tank only. Do not attempt to add coolant by removing the radiator cap. Coolant in the radiator is under pressure and is very hot and can cause serious burns.



Coolant Replacement

The coolant in your scooter should be replaced by your local authorized KYMCO dealer, unless you have the proper tools, access to service data, and are technically qualified.

NOTE: Always add coolant to the reserve tank. Do not attempt to add coolant by removing the radiator cap.

 **WARNING**

Removing the radiator cap while the engine is hot can cause the coolant to spray out, seriously burning you. Always let the engine and radiator cool down before removing the radiator cap.

Coolant Recommendation

It is your responsibility to have your scooter serviced so that it has the proper type and amount of coolant in the cooling system and engine. The coolant must be in good condition and have the proper ration of antifreeze and distilled water to prevent freezing, overheating, and corrosion. When servicing the coolant, you should arrange to use only high quality ethylene glycol antifreeze that contains corrosion protection inhibitors specifically formulated for use in aluminium engines (see the antifreeze container label).

A 50:50 solution of antifreeze and distilled water is required for the cooling system of your scooter. This coolant solution is recommended for most operating temperatures and provides good corrosion protection.

 **CAUTION**

Use only low-mineral drinking water or distilled water as a part of the antifreeze solution. Water that is high in mineral content or salt may be harmful to the aluminium engine. Using coolant with silicate inhibitors may cause premature wear of water pump seals or blockage of radiator passages.

If you are using your scooter in an environment where it will encounter freezing temperatures, you should have a higher concentration of antifreeze installed by your local authorized KYMCO dealer to provide additional protection against freezing the engine. This higher concentration should not exceed 60% antifreeze-to-distilled water.

During warmer temperatures, bring the antifreeze ratio back to the standard ratio. A concentration of less than 40:60 (40% antifreeze) will not provide proper corrosion protection.

Side Stand

Your scooter's side stand is not only necessary when you park, but it contains an important safety feature. This feature cuts off the ignition if you try to ride the scooter while the stand is down.

Perform the following side stand inspection.

Interlock Function Check:

Check the side stand ignition cut off system:

1. Place the scooter on its centre stand.
2. Put the side stand up and start the engine.
3. Lower the side stand. The engine should stop as you put the side stand down.

NOTE: If the side stand system does not operate as described, see you local authorized KYMCO dealer for service.

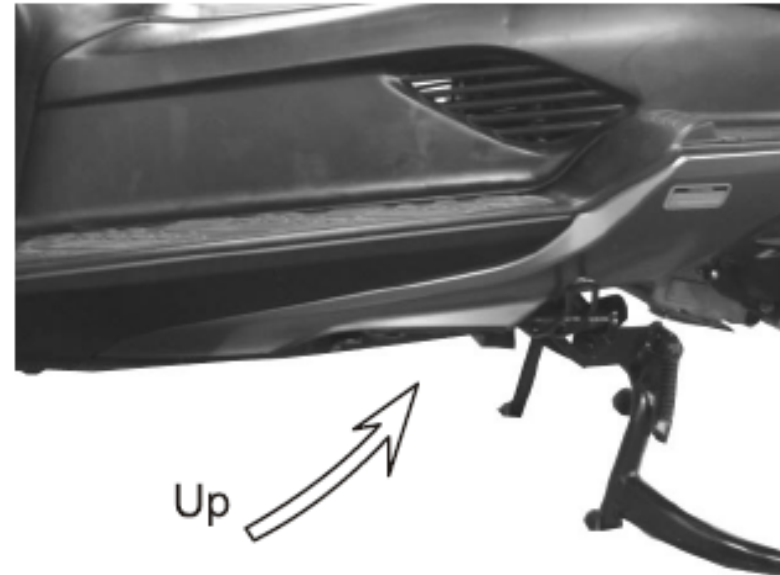

BRAKE FLUID



Brake Fluid Inspection Level

With the scooter in an upright position, check the front and rear fluid levels.

The level should be above the lower level mark. If the level is at or below the lower level mark "L", check the brake pads for wear.

NOTE: Other checks – make sure there are no fluid leaks. Check for deterioration or cracks in the hoses and fittings.

BRAKE FLUID TYPE: DOT 4



WARNING

Worn brake pads should be replaced immediately. If the brake pads are worn, have your brake system inspected for leaks. Do not ride your scooter unless the brakes are in perfect working order.



BRAKE LEVER ADJUSTERS



Brake Lever Adjusters

There is an adjuster on each brake lever. Each adjuster has four positions so that the released lever position can be adjusted to suit the rider's hands.

To adjust the distance of the lever from the handlebar grip, push the lever (1) forward and turn the adjuster knob (2) to align the numbers with the arrow mark (3) on the lever holder.

NOTE: The distance from the grip to the release lever is at its closest at number 4 and furthest away at number 1.



WARNING

For appropriate brake action, make sure the groove of the adjusting nut is aligned with the pin in the brake arm.

Inspect the brake pad and shoe thickness to verify that there is enough material for the brakes to function properly

1. If the wear indicator grooves in the front brake pads(3) or rear brake pads (4) are no longer visible, it is an indication that the brake pads are worn and require replacement.

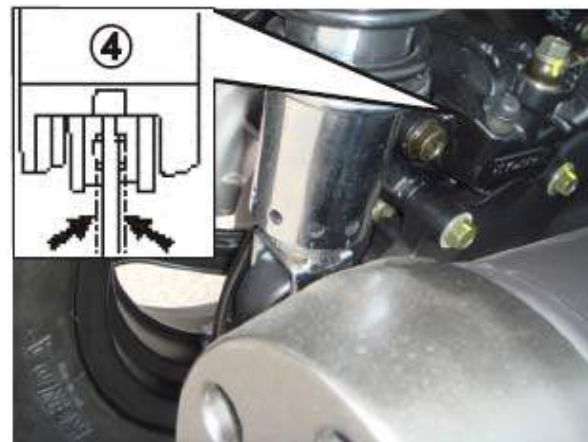
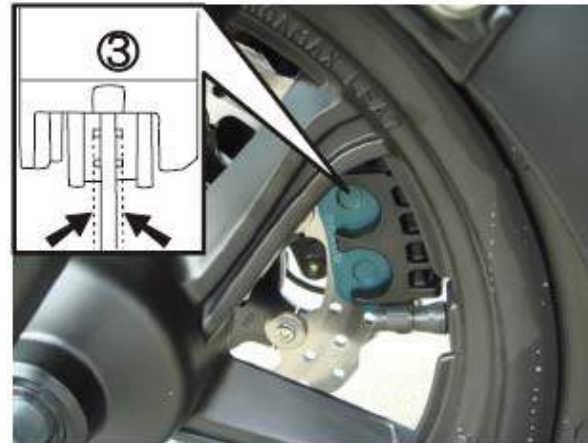

WARNING

The brake pads will wear quickly if the lever is continually applied during riding (dragging the brake). Consult your local authorized KYMCO dealer for braking system service.

BATTERY & FUSE



Battery

Your KYMCO scooter is equipped with a maintenance-free (sealed) battery, so it is not necessary to check the battery's electrolyte level or add distilled water.

NOTE: If your battery seems weak and/or is leaking electrolyte (causing hard starting or other electrical troubles), contact your local authorized KYMCO dealer immediately .

CAUTION

Your battery is a maintenance-free type and can be permanently damaged if the cap strip is removed.
Charge the battery with a charger specifically designed for use with a maintenance-free type battery. Using another type of charger can damage the battery.



Fuse

When frequent fuse failures occur, it usually indicates a short circuit or an overload in the electrical system.

NOTE: See your local authorized KYMCO dealer for electrical system diagnosis and repair.

WARNING

Never use a fuse with a different rating from that specified. Serious damage to the electrical system or a fire hazard may result, causing a dangerous loss of lights or engine power.

Fuses List:

- 30A – CHARGE FUSE:** Protects battery charging system
- 15A – MAIN FUSE:** Protects all electrical circuits
- 15A – HEAD-HI/LO FUSE:** Protects the headlight high/low beam and clock
- 10A – IGNITION FUSE:** Protects the ignition system
- 10A – FAN FUSE:** Protects the cooling fan motor

 **WARNING**

Failure to follow these warnings may result in an accident due to tire failure. The tires on your scooter are a crucial link between your scooter and the road. You and your passenger's personal safety are dependant upon the condition of your scooter's tires.

Follow these instructions:

- Check tire condition and pressure, and adjust the inflation pressure before each ride.
- Avoid overloading your scooter.
- Replace a tire when worn to the specified limit, or if you find any damage such as cuts or cracks.
- Always use the proper size and type of tires as specified in this Owner's Manual.
- Balance the wheel after tire installation.
- Read this section of the Owner's Manual carefully.

Failure to perform a reasonable break-in of the tires could cause the tires to slip and lose control. Use extra care when riding on new tires, as the grip will be limited. Perform proper break-in of the tires, as stated in the break-in recommendation section of this manual. Avoid hard acceleration, hard cornering, and hard braking for the first 160 kms (100 miles).

NOTE: Check the tire inflation pressure and tire tread condition at the periods listed in the periodic maintenance schedule. For maximum safety and good tire life, the tire pressures should be inspected more often.

Tire pressure

Insufficient air pressure in the tires not only accelerates tire wear, but it also affects the stability of your scooter. Underinflated tires make smooth cornering difficult, and overinflated tires decrease the amount of tire in contact with the ground, which can lead to skids and loss of control. Make sure that the tire pressures on your scooter are within the specified limits at all times.

NOTE: Tire pressure should only be adjusted when the tires are cold.

FRONT TIRE (rider only)	29.0 PSI (2.0 kg/cm ²)
REAR TIRE (rider only)	32.0 PSI (2.25 kg/cm ²)
FRONT TIRE (rider & passenger)	29.0 PSI (2.0 kg/cm ²)
REAR TIRE (rider & passenger)	32.0 PSI (2.25 kg/cm ²)

Cleaning

Clean your scooter regularly to protect the surface finishes and inspect for damage, wear, and oil, coolant or brake fluid leakage. Avoid cleaning products that are not specifically designed for scooter, motorcycle, or automobile surfaces. Nonspecific cleaners may contain harsh detergents or chemical solvents that could damage the metal, paint, and plastic on your scooter.

NOTE: If your scooter is still warm from recent operation, give the engine and exhaust system time to cool off before washing. Avoid the use of high pressure water spray (typical in coin-operated car washes), as the powerful spray can damage components on your scooter.

Washing your scooter

1. Rinse the scooter thoroughly with cool water to remove any loose dirt.
2. Clean the scooter with a sponge or soft cloth using cool water. Avoid directing water at muffler outlets and electrical parts.
3. Clean the plastic parts using a cloth or sponge dampened with a solution of mild detergent and water. Rub the soiled area gently, rinsing it frequently with fresh water. Take care to keep brake fluid or other chemical solvents away from the scooter, as they will damage the plastic and painted surfaces.
4. After cleaning, rinse the scooter thoroughly with plenty of clean water. This rinsing is required to remove detergent residue which can corrode alloy parts.
5. Dry the scooter and then start the engine, allowing it to run for several minutes.
6. Test the brakes before riding the scooter. Several applications of the brakes may be necessary to restore normal braking performance.

NOTE: The inside of the headlight lens may become clouded immediately after washing the scooter. Moisture condensation inside the headlight lens will disappear gradually as it is heated by the headlight. After washing, run the engine while keeping the headlight on to dissipate any condensation.

NOTE: Due to water on the brake components, braking efficiency may be temporarily impaired immediately after washing the scooter. Anticipate longer stopping distances to avoid a possible accident.



CLEANING YOUR SCOOTER



Cleaning the Windshield

Using plenty of water, clean the windshield with a soft cloth or sponge (avoid using detergents or any kind of chemical cleaner on the windshield). Dry with a soft, clean cloth. For a dirtier windshield, use a diluted, neutral detergent with a sponge and plenty of water. Make sure to wash off all of the detergent (detergent residue may cause windshield cracks).

Replace the windshield if scratches cannot be removed and they obstruct clear vision.

Do not let battery electrolyte, brake fluid or other acid chemicals get on the windshield and screen garnish. They will damage the plastic.



**Do not wipe with organic solvent (ex. gas thinner, etc).
Use neutral soap to clean windshield.**

Finishing touches:

After washing your scooter, consider using a commercially available spray cleaner/polish or a quality liquid or paste wax to enhance and protect the paint's finish. Use only a nonabrasive polish or wax made specifically for scooters, motorcycles, or automobiles. Apply the polish or wax according to the instructions on the container.

Removing road salt

The salt used in some communities to prevent road icing can become very corrosive to your scooter. Wash your scooter as soon as possible if it comes in contact with road salt (or sea water).

1. Clean the scooter using cool water (see page 49). Do not use warm water, as this will increase the corrosive effect of the salt.
2. Dry the scooter and protect painted and metal surfaces with wax or polish.

Painted aluminum wheel maintenance

Even if protected by paint, aluminum may corrode from contact with dirt, mud, or road salt. Clean the scooter's wheels with a wet sponge and mild detergent. Avoid stiff brushes, steel wool, or cleaners containing abrasives or chemical compounds. After washing, rinse with plenty of water and dry with a clean cloth . Apply touch-up paint to the wheels where damage has occurred.

Exhaust pipe maintenance

The exhaust system is stainless steel, but it can become stained by oil or mud. If necessary, remove heat stains with a liquid kitchen-counter

Storage Guide

Extended storage, such as for the winter months, requires that you take certain steps to reduce the effects of deterioration from the non-use of your scooter. Whenever possible, perform any necessary periodic maintenance or repairs before storage so the scooter will be in good condition for riding when it is removed from storage.

Storage:

1. Change the engine oil and filter.
2. Drain the carburetor (if equipped) and empty the fuel tank into an approved gasoline container using a commercially available hand siphon or an equivalent method. Spray the inside of the tank with an aerosol rust-inhibiting oil. Close the fuel filler cap on the fuel tank.
3. To prevent rusting in the cylinder, perform the following:
 - a. Remove the spark plug cap from the spark plug, and use tape or string to secure the cap to any convenient plastic body part so that it is positioned away from the spark plugs.
 - b. Remove the spark plug from the engine and store it in a safe, dry place. Do not connect the spark plug to the spark plug cap.
 - c. Pour a tablespoon (15 - 20 cc) of clean engine oil into the cylinder and cover the spark plug hole with a piece of cloth.
 - d. Crank the engine several times to distribute the oil.
 - e. Reinstall the spark plug and spark plug cap.
4. Remove the battery. Store it in an area protected from freezing temperatures and direct sunlight. Slow charge the battery once a month (use a quality charger designed for use on a maintenance-free type battery).
5. Wash and dry the scooter. Wax all painted surfaces. Coat the chrome or bare aluminum parts with rust inhibiting oil.
6. Inflate the tires to their recommended pressures. Place the scooter on blocks to raise both tires off the ground.
7. Cover the scooter (don't use plastic or other coated materials) and store in an unheated area, free of excessive moisture, with a minimum of daily temperature variation. Do not store the scooter in direct sunlight, as the sun's UV rays can damage the body work and other components.

**WARNING**

Gasoline is highly flammable and explosive. You can be burned or seriously injured when handling fuel. Stop the engine and keep heat, sparks, and flame away. Refuel the scooter outdoors and wipe up any spills immediately.

Removal from storage:

1. Uncover and clean the scooter.
2. Change the engine oil if more than 1 month has passed since the start of storage.
3. Charge the battery as required (use a quality charger designed for use on a maintenance-free type battery). Install the battery.
4. Drain any excess aerosol rust-inhibiting oil from the fuel tank. Fill the fuel tank with fresh gasoline.
5. Perform all the pre-ride inspection checks (see pages 28). Test ride the scooter at low speeds in a safe riding area, away from traffic.

SPECIFICATIONS – DOWNTOWN 300i



Dimensions

Overall length	88 in (2200 mm)
Overall width	32 in (800 mm)
Overall height	56 in (1410 mm)
Wheel base	62 in (1545 mm)

Capacities

Engine oil	1.5 L
Transmission oil	0.23 L
Fuel tank	12.5 L
Net Weight	441 lbs (187 kg)

Electrical

Ignition Type	Inductive Ignition Coil
Ignition Timing	ECU control
Battery	12V10AH
Headlight	12V 35 / 35W X 2
Tail/Brake Light	12V 5W / 21W
Turn Signal Light (Front/Rear)	12V 21W / 10W
Fuse	30A / 15A / 10A

Engine

Type	Four-stroke OHC
Valve Train	OHC & CENTER PIVOT
Displacement	298.9 cc
Bore and stroke	2.91 in x 2.88 in (72.7 x 72 mm)
Compression ratio	10.8:1
Max. Horsepower Engine	29 ps / 8500 rpm
Max. Torque Engine	2.7 kg.m / 6500 rpm
Spark plug	CR7E
Idle speed	1600 RPM
Cooling system	Liquid Cooled
Starting system	Electric starter
Transmission	Automatic CVT

Chassis

Tire size, front	120/80-14
Tire size, rear	150/70-13
Brake (front)	Disc type
Brake (rear)	Disc type

Crankcase Emission Control System

Your **Downtown 300i** engine is equipped with a closed crankcase system. Blow-by gasses are routed back into the combustion chamber via the intake system. This system does not allow the blow-by gases to enter the atmosphere.

Exhaust Emission Control System

The exhaust emissions from your **Downtown 300i** scooter are controlled by engine design, factory-set fuel delivery, ignition settings, and exhaust system design. This system also includes a catalyzer in the exhaust system.

Noise Exhaust Emission Control System

The engine, intake, and exhaust systems of your **Downtown 300i** scooter were designed to comply with national, provincial and local noise level requirements. Do not modify the engine, intake, or exhaust components, as doing so will affect compliance of these noise level requirements.

Please do not modify or change any KYMCO-designed components that may alter the sound or emission level from your Downtown 300i scooter.



KYMCO 2 YEAR LIMITED WARRANTY SCOOTERS AND MOTORCYCLES

KYMCO CANADA warrants all parts of the vehicle except those listed under the caption "What is not covered" (See below). This warranty covers any repairs needed to correct defects in materials or workmanship. **KYMCO** is committed to producing the highest quality of scooters, motorcycles, UTVs, and ATVs. All of our authorized dealers are dedicated to providing the best care and service for your vehicle. We appreciate your business and value your feedback. You can reach us anytime at: www.kymco.ca

What you must do...

You must properly use, maintain and care for the vehicle as outlined in the KYMCO owner's manual. You must maintain a record of the vehicle's required periodic service and inspection. Periodic service and inspections are considered regular maintenance and are not reimbursable. Follow all safety instructions in your owner's manual and read all warning labels carefully. Remember to always wear safety gear when operating your scooter or motorcycle.

What your Authorized KYMCO dealer must do...

Warranty repairs will be made at no charge for parts or labour. Any needed parts replacement will be made with new parts. Any implied warranty of merchantability and fitness for a particular purpose shall be limited to the duration of this written warranty. Your dealer will provide you with verbal instructions for operating your vehicle safely and will offer you the following safety equipment with your purchase:

- Helmet
- Goggles
- Gloves
- Boots
- Jacket
- Clothing

How long is the Warranty?

The warranty is effective as listed below or 20,000 kilometres (whichever comes first) from the date of purchase by the original owner.

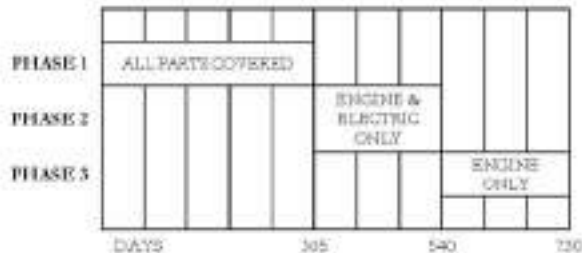

Vehicle Identification Number	Make
Dealer Name	Dealer Number
Customer Name	Warranty Card Number
Address	Postal Code
City	Telephone Number

WHAT IS NOT COVERED? (WARRANTY EXCLUSIONS)

- Any damage resulting from negligence of the periodic maintenance;
- Any damage which results from repair, adjustment or maintenance operations by any methods other than those specified by KYMCO;
- Any damage which results from hard driving due to race, rally, or operation in a location not generally used for driving;
- Any damage which results from use beyond the limitations specified in the KYMCO Operations Manual such as overloading the vehicle, or any damage from the use under abnormal conditions;
- Any damage caused when the product is used as a rental vehicle;
- Any damage which results from use of non-genuine parts or accessories or fuel, lubricant or fluid not specified by KYMCO;
- Any damage due to improper storage or transport;
- Any damage which results from repair, adjustment or maintenance operations performed by any person other than KYMCO distributor or the Dealer;
- Any damage which results from modifications of the product;
- Any damage that results from the passage of time (natural fading or painted surfaces, plated surfaces, wheel peeling and other deterioration);
- Consumable replacement parts. KYMCO will not warrant parts/wears due to natural wear and tear such as spark plugs, drive chains, air cleaner elements, brake shoes, clutch disks, light bulbs, batteries, fuses, rubber parts, tubes and tires, oils and cables;
- Any damage which results from unavoidable natural disasters, fire, collision, theft, and second damages based on any of these occurrences;
- Sensational phenomena that do not affect performance or function of the product such as engine noise, vibration or seepage;
- Incidental or additional expenses incurred for making any claims such as those for towing, communications, hotels and meals, as well as any losses during maintenance period, such as loss of time, loss of business and rental car expenses;
- Scheduled maintenance and inspections fees.

I have read and understand this document including coverage, exclusions, and requirements of the KYMCO LIMITED WARRANTY. I have been made aware of the risks and of the safety precautions that should be considered when operating a scooter or motorcycle and are satisfied that proper instructions were provided and safety gear was offered at the time of purchase.

Dealer Signature	Customer Signature	Date of Purchase
------------------	--------------------	------------------

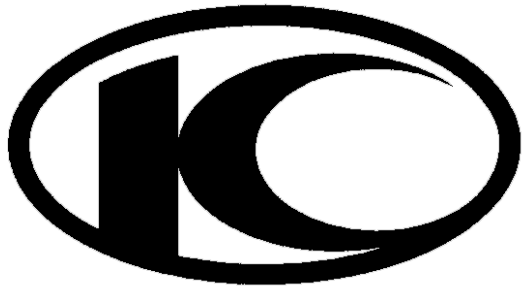
**KYMCO**

**KWANG YANG MOTOR CO.,LTD.
NO.35 Wan Hsing Street, San Min District
Kaohsiung, Taiwan, Republic of China**

**BECO Motor Intl. Inc.
First Canadian Edition 2011
All rights reserved. Any reproduction or
unauthorized use without the written permission of
KWANG YANG Motor Co., Ltd. is expressly prohibited.**