

**KLR650 Kawasaki
KLR500**



**Motorcycle Service Manual
Supplement**

Quick Reference Guide

General Information	1
Fuel System	
Engine Top End	3
Engine Right Side/Left Side	1
Cooling System	= 1
Engine Removal/Installation	°
Engine Bottom End/Transmission	1
Wheels/Tires	»1
Final Drive	*1
Brakes	10
Suspension/Steering	111
Controls/Instruments	121
Frame	13
Electrical System	14
Appendix	15
Supplement - 2000 - 2001 Models	16
Supplement - 2002 Model	17

This quick reference guide will assist you in locating a desired topic or procedure.

- Bend the pages back to match the black tab of the desired chapter number with the black tab on the edge at each table of contents page.

- Refer to the sectional table of contents for the exact pages to locate the specific topic required.

V%.f
?<«

>, rt.-.- : ^v? - : . . : - ■ -

? . - ● - V

EMISSION CONTROL INFORMATION

au.uf

To protect the environment in which we all live, Kawasaki has incorporated crankcase emission (1) and exhaust emission (2) control systems in compliance with applicable regulations of the United States Environmental Protection Agency and California Air Resources Board. Additionally, Kawasaki has incorporated an evaporative emission control system (3) in compliance with applicable regulations of the California Air Resources Board on vehicles sold in California only.

-X

1. Crankcase Emission Control System

This system eliminates the release of crankcase vapors into the atmosphere. Instead, the vapors are routed through an oil separator to the intake side of the engine. While the engine is operating, the vapors are drawn into combustion chamber, where they are burned along with the fuel and air supplied by the carburetion system.

2. Exhaust Emission Control System

This system reduces the amount of pollutants discharged into the atmosphere by the exhaust of this motorcycle. The fuel and ignition systems of this motorcycle have been carefully designed and constructed to ensure an efficient engine with low exhaust pollutant levels.

3. Evaporative Emission Control System

Vapors caused by fuel evaporation in the fuel system are not vented into the atmosphere. Instead, fuel vapors are routed into the running engine to be burned, or stored in a canister when the engine is stopped. Liquid fuel is caught by a vapor separator and returned to the fuel tank

The Clean Air Act, which is the Federal law covering motor vehicle pollution, contains what is commonly referred to as the Act's "tampering provisions."

"Sec. 203(a) The following acts and the causing thereof are prohibited...

- (3) (A) for any person to remove or render inoperative any device or element of design installed on or in a motor vehicle or motor vehicle engine in compliance with regulations under this title prior to its sale and delivery to the ultimate purchaser, or for any manufacturer or dealer knowingly to remove or render inoperative any such device or element of design after such sale and delivery to the ultimate purchaser.
- (3)(B) for any person engaged in the business of repairing, servicing, selling, leasing, or trading motor vehicles or motor vehicle engines, or who operates a fleet of motor vehicles knowingly to remove or render inoperative any device or element of design installed on or in a motor vehicle or motor vehicle engine in compliance with regulations under this title following its sale and delivery to the ultimate purchaser..."

(Continued on next page.)

NOTE

The phrase "remove or render inoperative any device or element of design" has been generally interpreted as follows:

1. Tampering does not include the temporary removal or rendering inoperative of devices or elements of design in order to perform maintenance.

2. Tampering could include:

a. Maladjustment of vehicle components such that the emission standards are exceeded.

b. Use of replacement parts or accessories which adversely affect the performance or durability of the motorcycle.

c. Addition of components or accessories that result in the vehicle exceeding the standards.

d. Permanently removing, disconnecting, or rendering inoperative any component or element of design of the emission control systems.

tp

*

WE RECOMMEND THAT ALL DEALERS OBSERVE THESE PROVISIONS OF FEDERAL LAW. THE VIOLATION OF WHICH IS PUNISHABLE BY CIVIL PENALTIES NOT EXCEEDING \$10,000 PER VIOLATION.

fc0'o'sfc>c.isi-r. \ x*v. • t v#-2s*rt- - xfx c-' :

ICS sg->Si . A-t- . .-u * • V*:-: . 2s- . V- ,zc - ^

C
**
.

TAMPERING WITH NOISE CONTROL SYSTEM PROHIBITED

Federal law prohibits the following acts or the causing thereof: (1) The removal or rendering inoperative by any person other than for purposes of maintenance, repair, or replacement, of any device or element of design incorporated into any new vehicle for the purpose of noise control prior to its sale or delivery to the ultimate purchaser or while it is in use, or (2) the use of the vehicle after such device or element of design has been removed or rendered inoperative by any person.

Among those acts presumed to constitute tampering are the acts listed below:

- Replacement of the original exhaust system or muffler with a component not in compliance with Federal regulations.
- Removal of the muffler(s) or any internal portion of the muffler(s).
- Removal of the air box or air box cover.
- Modifications to the muffler(s) or air intake system by cutting, drilling, or other means if such modifications result in increased noise levels.

E)
WARNING
CONTAINS
ASBESTOS
Breathing
asbestos dust
is dangerous
to health
Follow safety
instructions

This warning may apply to any of the following components or any assembly containing one or more of these components:—

Brake Shoes or Pads
Clutch Friction Material
Gaskets Insulators

SAFETY INSTRUCTIONS

- Operate if possible out of doors or in a well ventilated place.
- Preferably use hand tools or low speed tools equipped, if necessary, with an appropriate dust extraction facility. If high speed tools are used, they should always be so equipped.
- If possible, dampen before cutting or drilling.
- Dampen dust and place it in properly closed receptacle and dispose of it safely.

Foreword

This KLR650/500 Service Manual Supplement is designed to be used in conjunction with the KLR600 Service Manual (P/N 99924-1050- 01). The maintenance and repair procedures described in this Supplement are only those that are unique to the KLR650/500. Most service operations are identical to those for the KLR600. Complete and proper servicing of the KLR650/500 therefore requires both this Supplement and the base Service Manual.

This manual is designed primarily for use by trained mechanics in a properly equipped shop. However, it contains enough detail and basic information to make it useful to the owner who desires to perform his own basic maintenance and repair work. A basic knowledge of mechanics, the proper use of tools, and workshop procedures must be understood in order to carry out maintenance and repair satisfactorily. Whenever the owner has insufficient experience or doubts his ability to do the work, all adjustments, maintenance, and repair should be carried out only by qualified mechanics.

In order to perform the work efficiently and to avoid costly mistakes, read the text, thoroughly familiarize yourself with the procedures before starting work, and then do the work carefully in a clean area. Whenever special tools or equipment are specified, do not use makeshift tools or equipment. Precision measurements can only be made if the proper instruments are used, and the use of substitute tools may adversely affect safe operation.

For the duration of your warranty period, especially, we recommend that all repairs and scheduled maintenance be performed in accordance with this service manual. Any owner maintenance or repair procedure not performed in accordance with this manual may void the warranty.

To get the longest life out of your Motorcycle:

- Follow the Periodic Maintenance Chart in the Service Manual.
- Be alert for problems and non-scheduled maintenance.
- Use proper tools and genuine Kawasaki Motorcycle parts. Special tools, gauges, and testers that are necessary when servicing Kawasaki motorcycles are introduced by the Special Tool Manual. Genuine parts provided as spare parts are listed in the Parts Catalog.

- Follow the procedures in this manual carefully. Don't take shortcuts.
- Remember to keep complete records of maintenance and repair with dates and any new parts installed.

How to Use this Manual

In preparing this manual, we divided the product into its major systems. These systems became the manual's chapters. All information for a particular system from adjustment through disassembly and inspection is located in a single chapter.

The Quick Reference Guide shows you all of the product's systems and assists in locating their chapters. Each chapter in turn has its own comprehensive Table of Contents.

The Periodic Maintenance Chart is located in the General Information chapter. The chart gives a time schedule for required maintenance operations.

If you want spark plug information, for example, go to the Periodic Maintenance Chart first. The chart tells you how frequently to clean and gap the plug. Next, use the Quick Reference Guide to locate the Electrical System chapter. Then, use the Table of Contents on the first page of the chapter to find the Spark Plug section.

Whenever you see these WARNING and CAUTION symbols, heed their instructions! Always follow safe operating and maintenance practices.

WARNING

oThis warning symbol identifies special instructions or procedures which, if not correctly followed, could result in personal injury, or loss of life.

CAUTION

oThis caution symbol identifies special instructions or procedures which, if not strictly observed, could result in damage to or destruction of equipment.

This manual contains five more symbols (in addition to WARNING and CAUTION) which will help you distinguish different types of information.

NOTE

c This note symbol indicates points of particular interest for more efficient and convenient operation.

- Indicates a procedural step or work to be done, or indicates a procedural sub-step or how to do the work of the procedural step it follows. It also precedes the text of a WARNING, CAUTION, or NOTE.
- ♦ Indicates a conditional step or what action to take based on the results of the test or inspection in the procedural step or sub-step it follows.
- « Indicates a conditional sub-step or what action to take based upon the results of the conditional step it follows.

In most chapters an exploded view illustration of the system components follows the Table of Contents. In these illustrations you will find the instructions indicating which parts require specified tightening torque, oil, grease or a locking agent during assembly.

General Information

Table of Contents

Before Servicing	
Model Identification	1-2
Specifications	1-3
Periodic Maintenance Chart	1-6
Torque and Locking Agent	1-7
Cable, Wire, and Hose Routing	1-10

*Refer to Base Manual

1-2 GENERAL INFORMATION

Model Identification

KL650-A1:



KL500-A1 :



Specifications

Items	KL 650-A1, A2,A3,A4,A5,A6,A7,A8,A9	KL500-A1, A2
Dimensions:		
Overall length	2 290 mm, ©©© 2 205 mm, ® (gy) (D © <§£>©(§\$) 2 250 mm	*
Overall width	940 mm	*
Overall height	1 345 mm	*
Wheelbase	1 495 mm	*
Road clearance	240 mm	■*
Seat height	890 mm	*
Dry weight	153 kg, © 153.5 kg	*
Curb weight: Front	81 kg, (§) 81.5 kg	*
Rear	97 kg	*
Fuel tank capacity	23 L	*
Performance:		
Climbing ability		#
Braking distance	12.5 m from 50 km/h	#
Minimum turning radius	2.4 m	*
Engine:		
Type	4-stroke, DOHC, 4-valve, 1-cylinder	*
Cooling system	Liquid cooled	■*
Bore and stroke	100.0 x 83.0 mm	89.0 x 80.0 mm
Displacement	651 mL	497 mL
Compression ratio	9.5 : 1	*
Maximum horsepower	35.3 kW (48 PS) @6500 r/min (rpm) © 34.2 kW (46.5 PS) @6500 r/min (rpm)UTAC's norms © 19.9 kW (27 PS) @5800 r/min (rpm):DIN © -A3 19.9 kW (27 PS) @5500 r/min (rpm): DIN © -A3 32.4 kW (44 PS) @6500 r/min (rpm)	29.4 kW (40 PS) @7 500 r/min (rpm)
Maximum torque	54.9 N-m (5.6 kg-m, 40.5 ft-lb) @5500 r/min (rpm) © 45.1 N-m (4.6 kg-m, 33.3 ft-lb) @2500 r/min (rpm): DIN © -A3 48 N-m (4.9 kg-m, 35 ft-lb) @2300 r/min (rpm): DIN © -A3 49 N-m (5.0 kg-m, 36 ft-lb) @5000 r/min (rpm)	38.2 N-m (3.9 kg-m, 28.2 ft-lb) @ 6 000 r/min (rpm)
Carburetion system	Carburetor, Keihin CVK40	*
Starting system	Electric	*
Ignition system	CDI	»
Timing advance	Electronically advanced	*
Ignition timing	From 10° BTDC @1 300 r/min (rpm) to 30° BTDC @3 300 r/min (rpm)	
Spark Plug	NGK DPR8EA-9 or ND X24EPR-U9 ®(D©© NGK DP8EA-9, orND X24EP-U9	# *

GENERAL INFORMATION 1-5

Items	KL 650-A1 ,A2,A3,A4,A5.A6,A7,A8,A9	KL500-A1, A2
Rear suspension:		
Type	Swing arm (uni-trak)	*
Wheel travel	230 mm	*
Brake type:		
Front	Single disc	*
Rear	Single disc	*
Electrical Equipment:		
Battery	12V 14 Ah	*
Headlight:		
Type	Semi-Sealed beam	*
Bulb	12 V 60/55 W (quartz-halogen)	*
Tail/brake light	12 V 5/21 W, ©©© 12 V 8/27 W	*
Alternator:		
Type	Three-phase AC	*
Rated output	14 A @ 8 000 r/min (rpm), 14 V	*
Voltage regulator:		
Type	Short-circuit	*

Specifications subject to change without notice, and may not apply to every country.

* : Same as KL650-A1

Abbreviation

© : Australian Model		Italian Model
@) : Austrian Model	©	South African Model
© : U.K. Model		Spanish Model
© : Canadian Model	©	U.S. Model
@> : Californian Model		Greek Model
© : French Model © : West German Model		

1-6 GENERAL INFORMATION

Periodic Maintenance Chart

The scheduled maintenance must be done in accordance with this chart to keep the motorcycle in good running condition. The initial maintenance is vitally important and must not be neglected.

OPERATION	FREQUENCY	Whichever comes firstly	ODOMETER READING	See Page
<u>Spark plug — clean</u>		Every		(14-14)
<u>Spark plug — check</u>				(14-14)
<u>Valve clearance —</u>				(3-7)
<u>Air cleaner element — clean</u>				(2-7)
<u>Air cleaner element — replace</u>	5			2-5
<u>Throttle grip play — check *</u>				12-5
<u>Idle speed — check</u>				(2-4)
<u>Fuel system — check</u>				(2-8)
<u>Coolant — change</u>	2			(5-4)
<u>Spark arrestor — clean</u>				3-7
<u>For positive model emission control system — check (for © model)*</u>				(2-10)
<u>Engine oil — change</u>		Year		4-7
<u>Oil filter — replace</u>				(4-5)
<u>Radiator hoses, connections — check*</u>		year		(5-8)
<u>Fuel hoses, connections — check*</u>				
<u>Fuel hose — replace</u>	4			
<u>Balancer chain tension — adjust</u>				(4-4)
<u>Clutch — adjust</u>				(4-8)
<u>Drive chain wear — check</u>				(9-9)
<u>Drive chain — lubricate</u>		300 km		(9-5)
<u>Drive chain slack — check</u>		800 km		9-3
<u>Brake lining wear — check</u>				(10-4)
<u>Brake fluid level — check*</u>		mont		(10-4)
<u>Brake fluid — change</u>	2			(10-4)
<u>Brake hoses, connections —</u>				
<u>Brake hose — replace</u>	4			
<u>Master cylinder cup and dust seal</u>	2			
<u>Caliper piston seal and dust seal</u>	2			
<u>Brake light switch — check *</u>				(10-11)
<u>Steering — check</u>				(11-6)
<u>Steering stem bearing — lubricate</u>	2			(11-7)
<u>Front fork oil — change</u>				11-
<u>Tire wear — check</u>				(8-8)
<u>Spoke tightness and rim runout — check *</u>				(8-6)
<u>Swing arm pivot, uni-trak linkage — lubricate</u>				(11-11)
<u>Battery electrolyte level — check</u>		mont		(14-15)
<u>General lubrication — perform</u>				15-
<u>Nut, bolt, and fastener tightness</u>		!_U		15-2

t : For higher odometer readings, repeat at the frequency interval established here. * :

Replace, add, adjust, clean, or torque if necessary.

©: Californian Model © : U.S. Model © : Canadian Model

(Page) See Base

GENERAL INFORMATION 1-7

Torque and Locking Agent

The following tables list the tightening torque for the major fasteners, and the parts requiring use of a non-permanent locking agent or liquid gasket.

Letters used in the "Remarks" column mean:

- L : Apply a non-permanent locking agent to the threads.
- LG : Apply liquid gasket to the threads.
- LS : Apply liquid gasket (silicone sealant) to the threads.
- M : Apply a molybdenum disulfide lubricant (grease or oil) to the threads and seated surface, or washer.

S : Tighten the fasteners following the specified sequence.

Fastener	Torque			Remarks
	N-m	kg-m	ft-lb	
Engine Top End:				
Cylinder head cover bolts	7.8	0.80	69 in-lb	
Camshaft cap bolts	12	1.2	104 in-lb	
Camshaft sprocket bolts	49	5.0	36	L
Oil pipe banjo bolts	20	2.0	14.5	
Cylinder head bolts: 10 mm	65	6.6	48	M, S
8 mm	18	1.8	13.0	S
6 mm	9.8	1.0	87 in-lb	S
Cylinder head nuts	25	2.5	18.0	S
Cylinder bolt	9.8	1.0	87 in-lb	S
Cylinder nuts	25	2.5	18.0	S
Engine Right Side/Left Side:				
Cover damper mounting bolts	9.8	1.0	87 in-lb	L
Clutch spring bolts	9.8	1.0	87 in-lb	
Clutch hub nut	130	13.5	98	
Primary gear nut	120	12.0	87	
Oil pressure relief valve	15	1.5	11.0	L
Balancer shaft (front) right end nut	44	4.5	33	
Balancer chain guide (inner) bolts				
8 mm	25	2.5	18.0	L
6 mm	12	1.2	104 in-lb	L
Shift return spring pin	-	-	-	L
Engine drain plug	23	2.3	16.5	
Oil pipe banjo bolts	20	2.0	14.5	
Cooling System:				
Radiator fan switch	7.4	0.75	65 in-lb	
Water temperature sender	15	1.5	11.0	LS
Impeller nut	9.8	1.0	87 in-lb	

1-8 GENERAL INFORMATION

Fastener	Torque			Remarks
	N-m	kg-m	ft-lb	
Engine Removal/Installation:	44	4.5	33	S
Engine mounting bolts and nuts				
10 mm				
8 mm	25	2.5	18.0	S
Engine mounting bracket bolts and nuts (8 mm)	25	2.5	18.0	
Swing arm pivot bolt and nut (14 mm)	98	10.0	72	S
Engine Bottom End/Transmission: Crankshaft bearing retainer screws				L
Shift drum pin plate bolt	12	1.2	104 in-lb	L
Wheels/Tires:	78	8.0	58	
Front axle nut				
Rear axle nut	93	9.5	69	
Spoke nipples	2.0-3.9	0.2 - 0.4	17-35 in-lb	
Final Drive:	9.8	1.0	87 in-lb	
Engine sprocket bolts				
Rear sprocket studs	-	-	-	L
Rear sprocket nuts	32	3.3	24	
Brakes:	8.8	0.90	78 in-lb	
Front master cylinder clamp bolts				
Rear master cylinder mounting bolts	23	2.3	16.5	
Caliper mounting bolts	25	2.5	18.0	
Disc mounting bolts	23	2.3	16.5	
Brake hose banjo bolts	25	2.5	18.0	
Air bleed valves	7.8	0.80	69 in-lb	
Brake lever pivot nut	5.9	0.60	52 in-lb	
Suspension/Steering:	25	2.5	18.0	
Front fork clamp bolts and nuts				
Air valves	12	1.2	104 in-lb	L
Fork top bolts	29	3.0	22	
Fork bottom Allen bolts	39	4.0	29	L
Fork drain screws	-	-	-	LG
Rear shock absorber mounting bolts and nuts:	59	6.0	43	
Upper (12 mm)				
Lower (14 mm)	98	10.0	72	
Swing arm pivot bolt and nut (14 mm)	98	10.0	72	
Rocker arm pivot bolt and nut (14 mm)	98	10.0	72	
Tie-rod bolts and nuts (14 mm)	98	10.0	72	
Steering stem head nut	39	4.0	29	

GENERAL INFORMATION 1-9

Fastener	Torque			Remarks
	N-m	kg-m	ft-lb	
Controls/Instruments:				
Handlebar clamp bolts	24	2.4	17.5	
Frame:				
Rear frame mounting bolts	25	2.5	18.0	
Electrical System:				
Spark plug	14	1.4	10.0	
Magneto flywheel bolt	175	18.0	130	
Starter motor mounting bolts	9.8	1.0	87 in-lb	
Starter clutch bolts	34	3.5	25	L

The table below, relating tightening torque to thread diameter, lists the basic torque for the bolts and nuts. Use this table for only the bolts and nuts which do not require a specific torque value. All of the values are for use with dry solvent-cleaned threads.

General Fasteners:

Threads dia. (mm)	Torque		
	N-m	kg-m	ft-lb
5	3.4 -4.9	0.35 - 0.50	30 - 43 in-lb
6	5.9 - 7.8	0.60 - 0.80	52 - 69 in-lb
8	14 - 19	1.4 - 1.9	10.0-13.5
10	25-34	2.6 - 3.5	19.0-25
12	44-61	4.5-6.2	33-45
14	73-98	7.4 - 10.0	54-72
16	115-155	11.5-16.0	83-115
18	165 - 225	17.0-23	125- 165
20	225 - 325	23-33	165-240

MO GENERAL INFORMATION

Cable, Wire, and Hose Routing

Control Cables

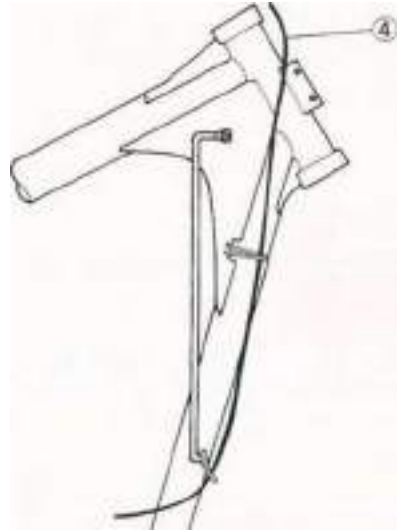
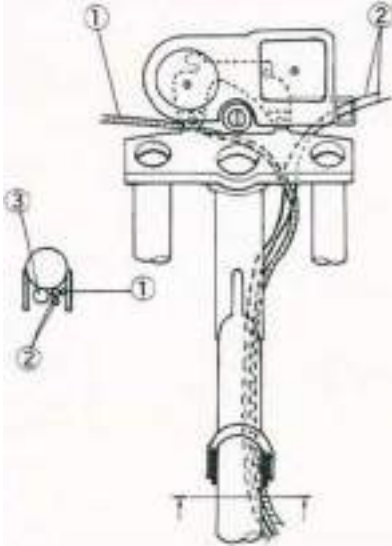

1. Choke Cable
2. Throttle Cable
3. Main Harness
4. Clutch Cable
5. To Meter Bracket
6. To Headlight
7. To Turn Signal Light
8. To City Light

9. Ground Lead
10. To Diode Assembly
11. To Turn Signal Relay
12. To Horn
13. To CDI Unit
14. To Water Temperature Sender
15. To Ignition Coil

16. To Magneto
17. To Neutral Switch and Pickup Coil
18. To Radiator Fan Relay
19. To Radiator Fan
20. To Radiator Fan Switch
21. Harness Position Mark
22. To Starter Relay
23. To Starter Circuit Relay
24. To Side Stand Switch
25. To Rear Brake Light Switch
26. To Fuses
27. To Battery
28. To Regulator/Rectifier
29. To Rear Harness

Electrical Wires

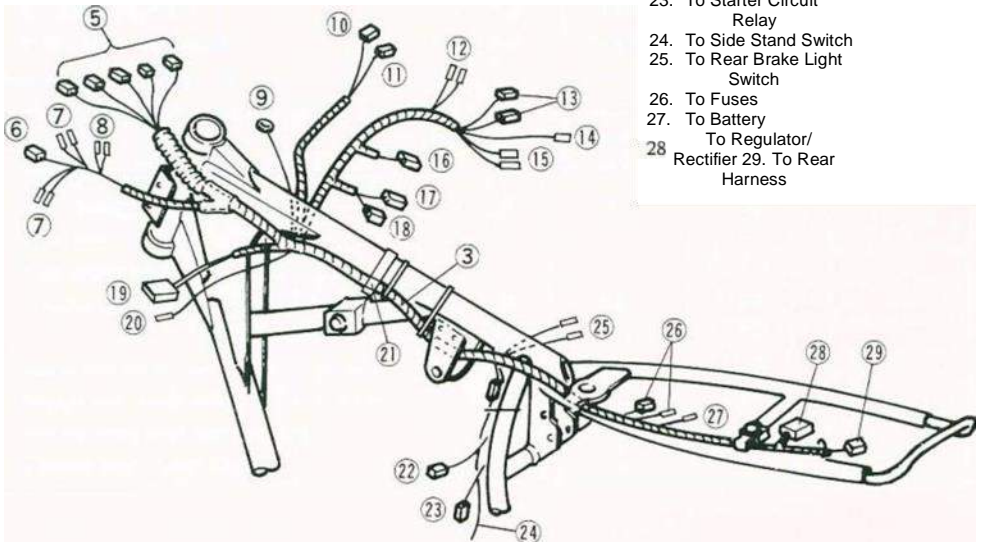

Electrical Wires

Viewed from A

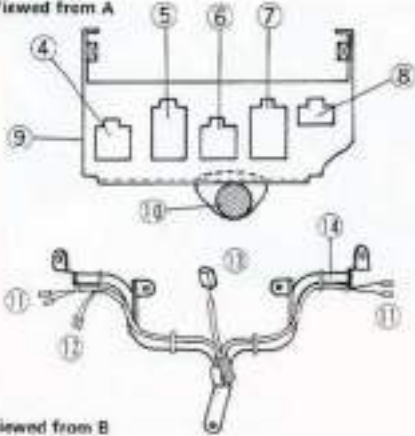

Viewed from B

- | | |
|----------------------|---------------------------------------|
| 1 LH Switch Leads | 13. To Headlight |
| 2 RH Switch Leads | 14. Headlight Bracket |
| 3 Starter Lockout | 15. Ground Lead |
| 4 Switch Leads RH | 16. Frame Top Tube |
| 5 Connector (Red) | 17. To Neutral Switch and Pickup Coil |
| 6 Meter 9P | 18. Main Harness |
| 7 Connector Ignition | 19. To Water Temperature Sender |
| 8 Switch 6P | 20. Ignition Coil |
| 9 Connector (Black) | 21. Spark Plug Cap |
| 10 LH Switch 9P | 22. Horn |
| 11 Connector (Red) | 23. Radiator Fan Connector |
| 12 Starter Lockout | 24. Turn Signal Relay |
| 13 Connector Meter | 25. Radiator Fan Relay |
| 14 Bracket Main | 26. CDI Unit 2P |
| 15 Harness To Turn | |
| 16 Signal Light To | |
| 17 Signal Light | |

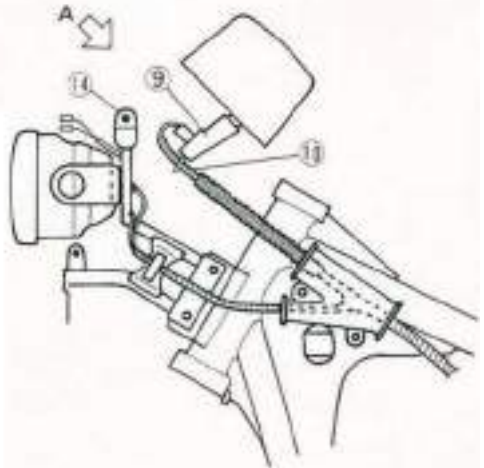

- | |
|---|
| 27. Neutral Switch and Pickup Coil 3P Connector |
| 28. Magneto 6P Connector |
| 29. CDI Unit 6P Connector |
| 30. CDI Unit |
| 31. Diode Assembly |

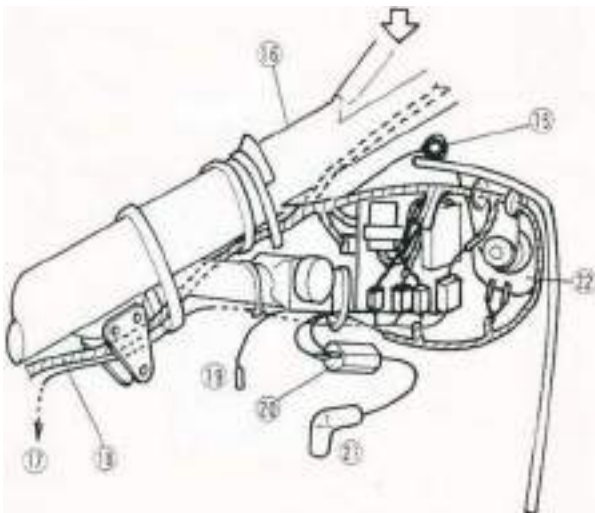

Viewed from C

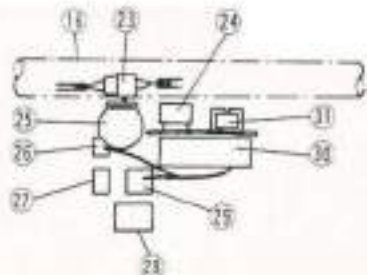

1-12 GENERAL INFORMATION

Electrical Wires

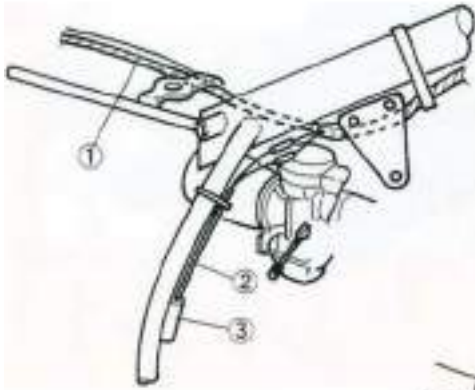

- 1. Main Harness
- 2. Rear Brake Light
- 3. Rear Brake Light
- 4. Magneto Leads
- 5. Neutral Switch and
- 6. To Fuses
- 7. To Battery
- 8. Battery (+) Lead
- 9. To Regulator/
- 10. To Rear Harness
- 11. Starter Relay
- 12. Ground Lead
- 13. Starter Motor Lead
- 14. Starter Circuit Relay

Switch Leads
Switch

Pickup Coil Leads

Rectifier

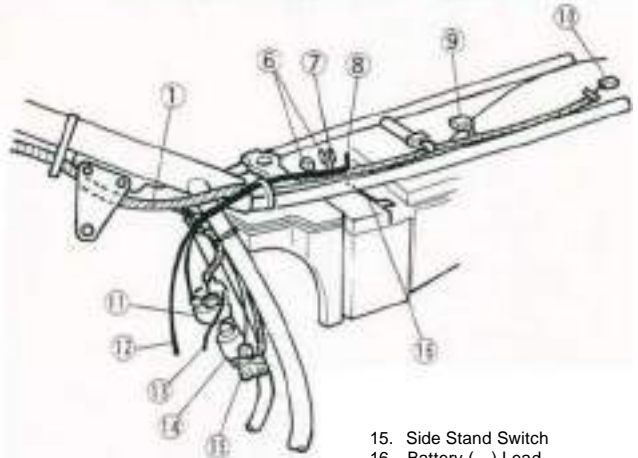

- 15. Side Stand Switch
- 16. Battery (-) Lead
- 17. Turn Signal Light Leads
- 18. Tail/Brake Light Leads
- 19. Rear Harness
- 20. License Plate Light Leads
- 21. Ground Lead
- 22. Radiator Fan Leads
- 23. Radiator Fan Switch

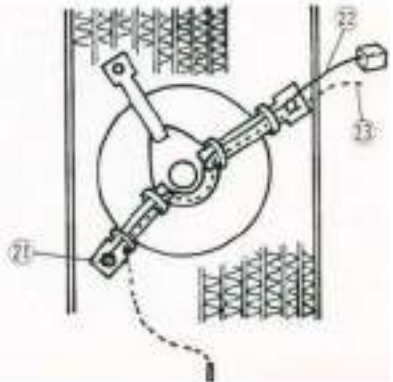
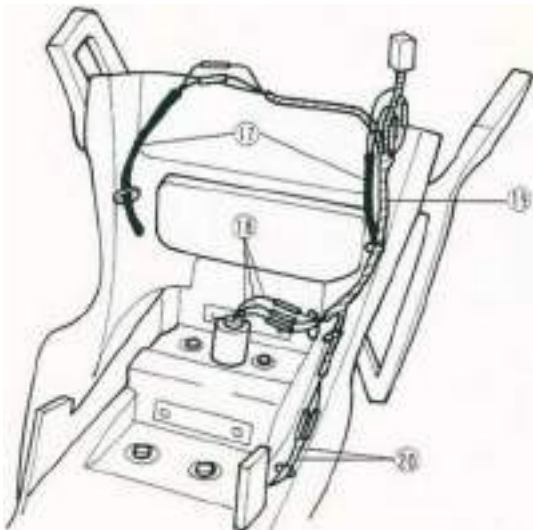

GENERAL INFORMATION 1-13

Fuel Hoses and Battery Vent Hose

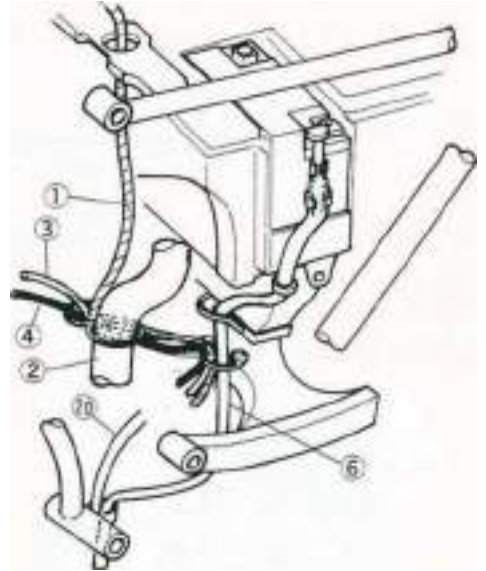
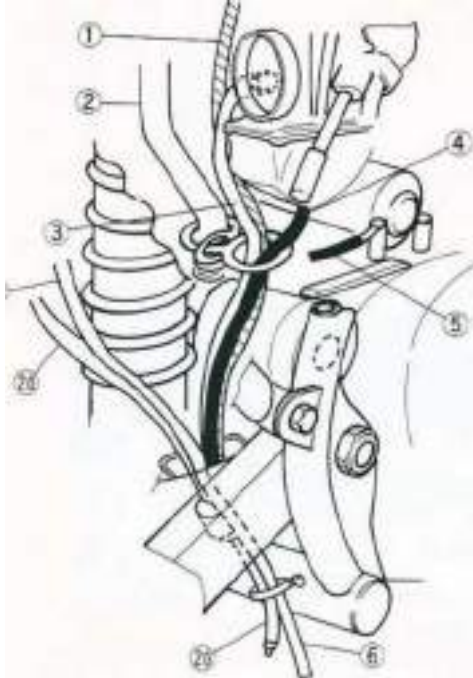

- | | |
|--------------------------------|--------------------------------------|
| 1. Fuel Tank Breather
Hose | 11. Purge Hose (Green) |
| 2. Crankcase Breather
Hose | 12. To Carburetor |
| 3. Carburetor Air Vent
Hose | 13. To Fuel Tap |
| 4. Carburetor Overflow
Hose | 14. Vacuum Hose (White) |
| 5. Ground Lead | 15. Liquid/Vapor
Separator |
| 6. Battery Vent Hose | 16. Breather Hose (Blue) |
| 7. Breather Hose (Blue) | 17. Hose |
| 8. To Fuel Tank | 18. Canister |
| 9. Fuel Return Hose (Red) | 19. To Canister |
| | 20. Air Cleaner
Drain Hose (A3 -) |
| 1. Air Cleaner | |

Vacuum Hoses and Breather Hoses (Californian Model)



Fuel System

Table of Contents

Exploded View	2-2
Service Data	2-4
Special Tool	
Fuel Tank.....	2-5
Removal Point.....	2-5
Carburetor.....	2-5
Adjustment.....	2-5
Idle Inspection.....	
Idle Adjustment	
High Altitude Performance Adjustment (U.S model)	2-5
Maintenance.....	
Service Fuel Level Inspection.....	
Service Fuel Level Adjustment	
Carburetor Disassembly	2-5
Disassembly Points.....	
Assembly Points.....	
Carburetor Installation.....	2-5
Adjustment After Installation.....	2-5
Air Cleaner.....	2-5
Element Removal.....	
Inspection and Cleaning.....	
Element Installation Points	2-5
Body Removal.....	
Body Installation Point.....	2-6
Fuel System Cleanliness.....	2-6
Inspection	*
Cleaning.....	
Fuel Tank and Cap Inspection.....	2-6
Evaporative Emission Control System (Californian Model).....	
Periodic Inspection.....	
Canister Inspection	
Liquid/Vapor Separator Inspection	
Separator Test	
Fuel Tank Inspection	

2-2 FUEL SYSTEM

Exploded View

A : Adhesive

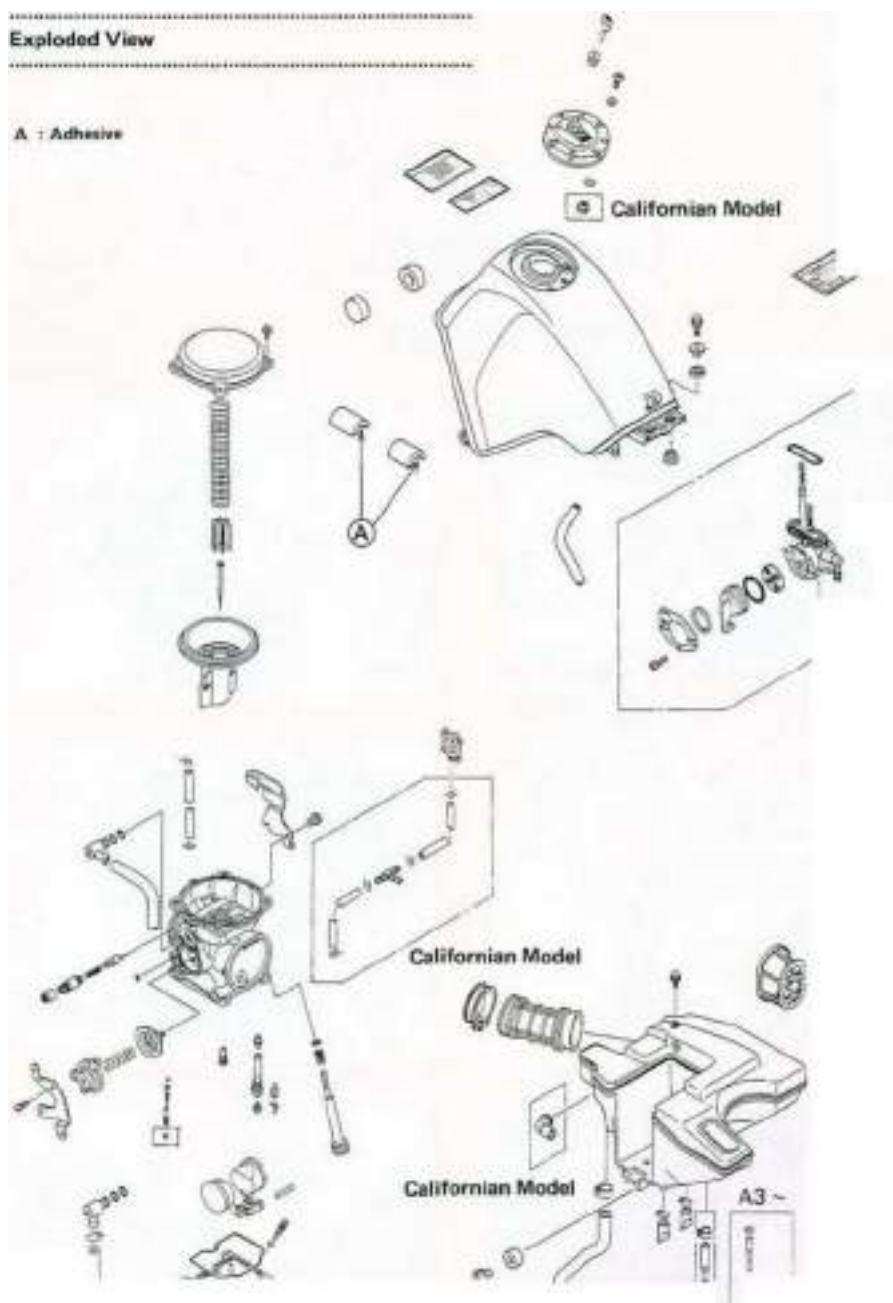

Californian Model

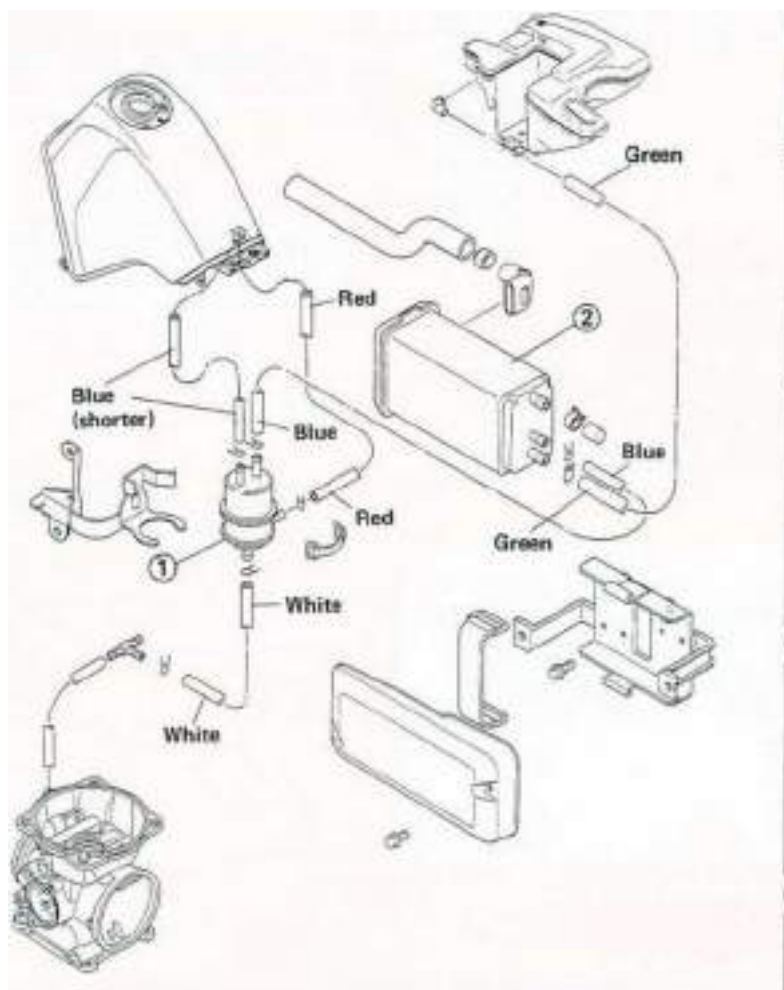

1. Liquid/Vapor Separator
2. Canister

2-4 FUEL SYSTEM

Specifications

Item	KL500-A1, A2	KL650-A1, A2	KL650-A3 ~
Carburetor:			
Idle speed	1300 ±100 r/min (rpm)	<—	<—
Standard specifications:			
Make, type	Keihin, CVK40	<—	<—
Main jet	#148	#150, © #148,	#145,
Main air jet	#50	® *155	@® #148
Needle jet	#6	<—, ® #7	#6
Jet needle	N31W	N31T, © N31R,	N74C, © N31R,
Pilot jet	#40	® N60B	® N60N
Pilot air jet	#80	#70	<—
Pilot screw	1 ³ A turns out	1 ³ /s turns out,	17. turns out.
Starter jet	#52	© - ©® 1V ₂	© -, ® 17<
Service fuel level	—0.5 ±1 mm	<—	<—
Float height	17.5 mm	<—	<—
Height altitude adjustment (US model):			
Main jet		#145	<—
Pilot jet		#38	<—
Air Cleaner:			
Element oil: Grade	SE class	<—	<—
Viscosity	SAE30	<—	<—

© : West German Model

© : U.S. Model ®: Swiss

Model

Fuel Tank

Removal Point

•Before removing the fuel tank or disconnecting the fuel hose from the fuel tap, turn the fuel tap lever to the OFF position to prevent fuel leaking out while the tank is removed or the hose is disconnected.

1 WARNING

Gasoline is extremely flammable and can be explosive under certain conditions. Turn the ignition switch OFF. Do not smoke. Make sure the area is well ventilated and free from any source of flame or sparks; this includes any appliance with a pilot light.

Carburetor

Adjustment:

High Altitude Performance Adjustment (US model)

To improve the Emission Control Performance of vehicle operated above 4 000 feet (1 219 meters), Kawasaki recommends the following Environmental protection Agency (EPA) approved modification.

NOTE

When properly performed, these specified adjustments are not considered to be emission control system "tampering" and vehicle performance is generally unchanged as a result.

•High altitude adjustments require replacement of certain carburetor jets.

High Altitude Carburetor Specifications

Main Jet:	#145
Pilot Jet:	#38

•After high altitude adjustments are performed, provide the customer with the Vehicle Emission Control Information Update Label and label installation instructions (P/N 99969-0614).

•Advise the customer that by law, the Vehicle Emission Control Information Update Label must be affixed to any vehicle modified with the high altitude adjustments.

NOTE

Off a vehicle with the high altitude adjustments is used below 4 000 feet (1 219 meters), the update label must be removed and the original carburetor parts must be reinstalled.

Carburetor Disassembly:
Carburetor Installation

Refer to the Base Manual, noting the following. •Refer to Cable, Wire, and Hose Routing in the chapter 1 for the carburetor overflow tube and air vent tube routing.

Adjustment after Installation

•Adjust the following.

- Throttle
- Grip Choke
- Lever Idle

Air Cleaner

Element Removal •Remove

the right side cover.

•Remove the screws and take off the air cleaner element cap.

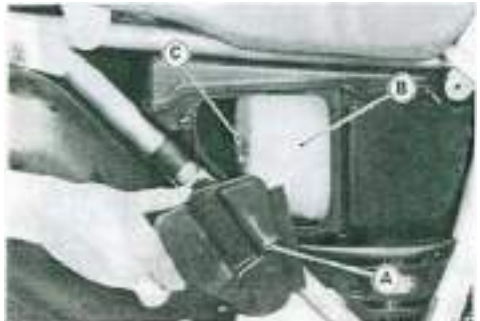

A. Element Cap C. Wing Head Bolt
B. Element

•Remove the wing head bolt and take off the air cleaner element.

•Push a clean, lint-free towel into the air cleaner housing to keep dirt or other foreign material from entering.



Off dirt gets through into the engine, excessive engine wear and possibly engine damage will occur.

Element Installation Points

•Coat the element lip with a layer of all purpose grease to assure a complete seal against the cleaner case.

•Be sure the foam gasket is in place in the groove in the element cap.

2-6 FUEL SYSTEM

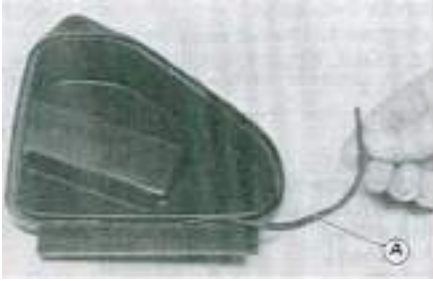

A. Foam Gasket

Body Installation Point

•If the air cleaner body drain tubes were removed, install them in place on the bottom of the housing. The longer drain tube including the air filter must be A. Air Vent Holes installed the rear side fitting (dirty side fitting).



A. Long Drain Tube B. Short Drain Tubes

CAUTION

•Do not apply compressed air to the air vent holes on the tank cap. This could cause damage and clogging of the labyrinth in the cap.

Fuel System Cleanliness

Fuel Tank and Cap Inspection

- Visually inspect the gasket on the tank cap for any damage.
- ♦Replace the gasket if it is damaged.
- Remove the hose(s) from the fuel tank, and open the tank cap.
- Check to see if the breather and water drain pipes (also the fuel return pipe for the US California vehicle) in the tank are not clogged. Check the tank cap breather too.
- *If the tank pipes are clogged, remove the tank and drain it and then blow the pipes free with compressed air.
- *If the tank cap breather is clogged, replace it.

Engine Top End

Table of Contents

Exploded View.....	3-2	Valve Maintenance.....	
Service Data.....	3-4	Valve Seat Inspection.....	
Special Tools.....		Valve Seat Repair.....	
Camshaft Chain Tensioner	3-6	Measuring Valve-to-Guide Clearance (Wobble Method).....	
Removal		Cylinder Head	3*6
Installation	3-6	Compression Measurement	
Cylinder Head Cover		Removal Point of Cylinder Head	
Adjustment before Head		Installation Points of Cylinder Head	3-6
Cover Installation.....		Adjustment and Operation after Installation	
Installation Points		Disassembly Points of Cylinder Head. ...	
Camshaft Chain Guides,		Cylinder Head Warp	
Camshaft Chain, Camshafts.....		Cylinder, Piston	3-7
Camshaft Removal Point		Removal Point of Piston.....	
Chain Guide Installation Point.....		Installation Points of PistonRings	3-7
Camshaft Installation Points		Installation Points of Cylinder Block. ...	
Assembly Points of Camshafts and Sprockets		Piston Ring End Gap	
Disassembly Point of Camshaft Sprocket Bolt		Cylinder Inside Diameter.....	
Camshaft Oil Clearance Inspection.....		Piston Diameter.....	
Camshaft Chain, Balancer Chain Wear . . .		Boring, Honing.....	*
KAWASAKI Automatic		Muffler.....	3-7
Compression Release.....		Installation Points	
Oil Pipes.....	3-	Spark Arrester Cleaning (U.S.model) . . .	3-7
Oil Pipe Installation Points	3-		
Valves			
Valve Clearance Adjustment			
Inspection			
Adjustment.....			
Measuring Valve Installed Height			

*Refer to Base Manual

3-2 ENGINE TOP END

Exploded View

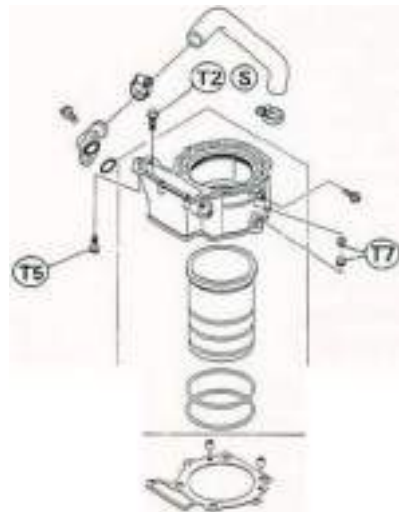
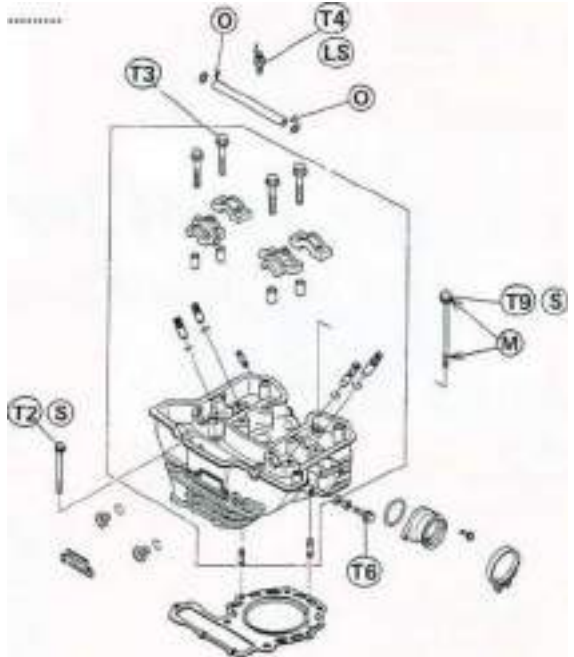

L : IMon-permanent Locking Agent
 LS: Liquid Gasket (Silicone Sealant)
 M : Molybdenum Disulfide Grease
 O : Engine Oil

- T1 : 7.8 N-m (0.80 kg-m, 69 in-lb)
- T2: 9.8 N-m (1.0 kg-m, 87 in-lb)
- T3: 12 N-m (<1.2 kg-m, 104 in-lb)
- T4: 15 N-m (1.5 kg-m, 11.0 ft-lb)
- T5: 18 N-m (1.8 kg-m, 13.0 ft-lb)
- T6: 20 N-m (2.0 kg-m, 14.5 ft-lb)
- T7: 25 N-m (2.5 kg-m, 18.0 ft-lb)
- T8: 49 N-m (5.0 kg-m, 36 ft-lb)
- T9: 65 N-m (6.6 kg-m, 48 ft-lb)



ENGINE TOP END 3-3

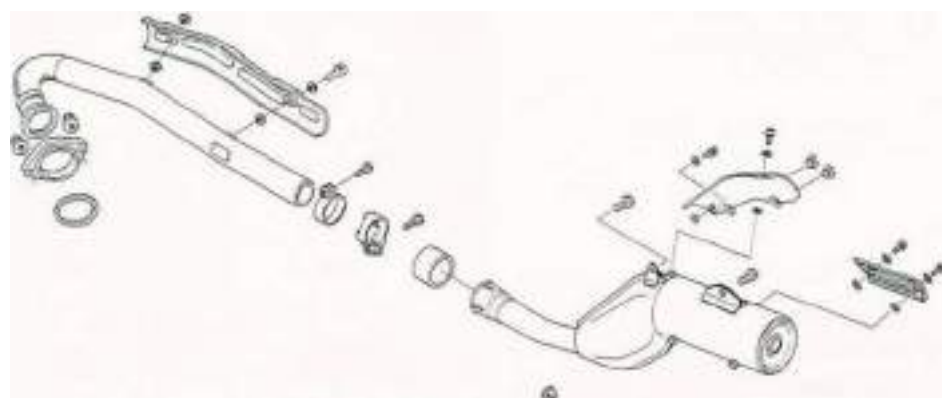
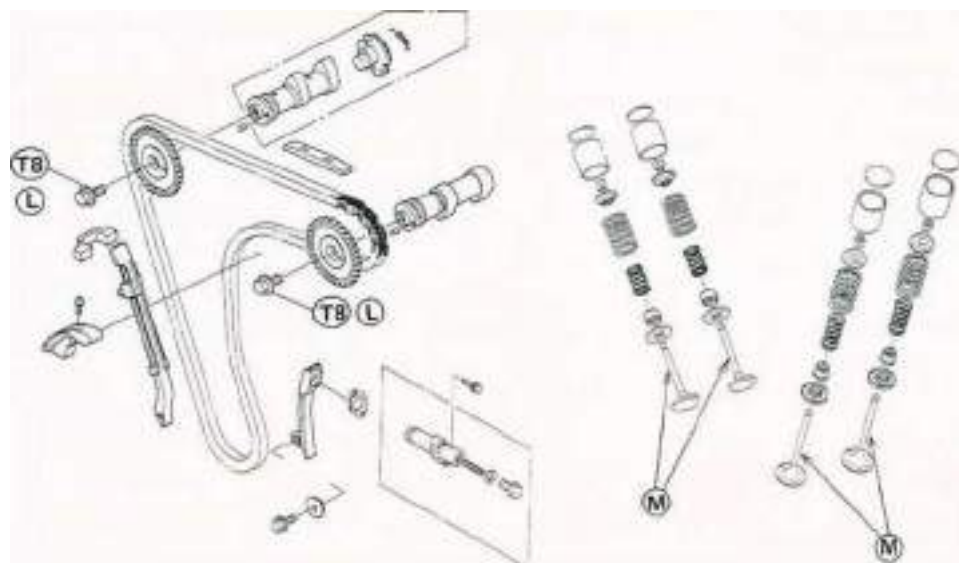

3-4 ENGINE TOP END

Service Data

Item		Standard	Service Limit
Camshafts, Chain:			
Cam height:	Inlet	36.75 — 36.85 mm	36.65 mm
	Exhaust	36.25 — 36.35 mm	36.15 mm
Camshaft bearing oil clearance		0.030 — 0.064 mm	0.15 mm
Camshaft journal diameter		22.949 - 22.970 mm	22.92 mm
Camshaft bearing inside diameter		23.000-23.013 mm	23.07 mm
Camshaft chain 20-link length		127.0 - 127.4 mm	128.9 mm
Balancer chain 20-link length		190.5 — 190.9 mm	193.4 mm
Valves:			
Valve clearance:	Inlet	0.10 — 0.20 mm	----
	Exhaust	0.15 — 0.25 mm	----
Valve head thickness:	Inlet	1.0 mm	0.5 mm
	Exhaust	1.0 mm	0.7 mm
Valve stem bend		Less than 0.01 mm TI R	0.05 mm TI R
Valve stem diameter:	Inlet	6.965 — 6.980 mm	6.95 mm
	Exhaust	6.955 — 6.970 mm	6.94 mm
Valve guide inside diameter		7.000 - 7.015 mm	7.08 mm
Valve guide/valve clearance (wobble method):			
	Inlet	0.04 — 0.11 mm	0.24 mm
	Exhaust	0.05 — 0.12 mm	0.24 mm
Valve seating area outside diameter			
	Inlet	36.9 — 37.1 mm	----
	Exhaust	31.9 — 32.1 mm	----
Valve seating area width		0.8 — 1.2 mm	----
Valve spring free length:	Inner	37.6 mm	36.2 mm
	Outer	40.5 mm	39.0 mm
Cylinder Head:			
Cylinder compression		530 - 855 kPa (5.4 - 8.7 kg/cm ² , 77 - 124 psi)	
Cylinder head warp		----	0.05 mm

ENGINE TOP END 3-5

Item	Standard	Service Limit
Cylinder, Piston:		
Cylinder inside diameter:	KL650 100.000- 100.012 mm	100.10 mm
	KL500 89.000-89.012 mm	89.10 mm
Piston diameter:	KL650 99.942 - 99.957 mm	99.80 mm
	KL500 88.942 - 88.957 mm	88.80 mm
Piston/cylinder clearance	0.043 — 0.070 mm	---
Piston ring/groove clearance:		
Top & 2nd	0.02 — 0.05 mm	0.16 mm
Piston ring groove width:		
Top & 2nd	1.21 - 1.22 mm	1.31 mm
Oil	2.81 — 2.83 mm	2.91 mm
Piston ring thickness:		
Top & 2nd	1.17 - 1.19 mm	1.10 mm
Piston ring end gap:		
Top & 2nd	0.2 — 0.4 mm	0.7 mm

3-6 ENGINE TOP END

Camshaft Chain Tensioner

Installation

- Remove the cap bolt and take off the spring.
- Unlock the ratchet stopper and push the rod into the tensioner body.



A. Ratchet Stopper B. Push Rod

- Install the chain tensioner with the gasket so that the arrow on it points downwards.



A. Arrow

- Install the spring and tighten the cap bolt with the gasket.

Oil Pipes

OH Pipe Installation Points

Refer to the Base Manual, noting the following. •Apply engine oil to both ends of the head oil pipe to prevent damage to the O-rings in the camshaft caps.

Head Oil Pipe



1. Camshaft Cap
2. O-ring
3. Oil Pipe
4. Apply engine oil.

Cylinder Head

Installation Points of Cylinder Head

Refer to the Base Manual, noting the following.

Cylinder Head Bolts and Nuts Tightening Torque and Sequence



- ◎ — ◎ : Cylinder Head Bolts (10 mm)
Torque them first to 20 N-m (2.0 kg-m, 14.5 ft-lb) and then to 65 N-m (6.6 kg-m, 48 ft-lb) following the tightening sequence.
- ◎ - ◎ : Cylinder Head Nuts
25 N-m (2.5 kg-m, 18.0 ft-lb)
- ◎ — ◎ : Cylinder Nuts (Retighten)
25 N-m (2.5 kg-m, 18.0 ft-lb)
- ◎ : Cylinder Head Bolt (8 mm)
18 N-m (1.8 kg-m, 13.0 ft-lb)
- @ - (J) : Cylinder Head Bolts (6 mm)
9.8 N-m (1.0 kg-m, 87 in-lb)

Cylinder, Piston

Installation Points of Piston Rings

Refer to the Base Manual, noting the following.

Cross Section of Piston Rings (Top and Second)

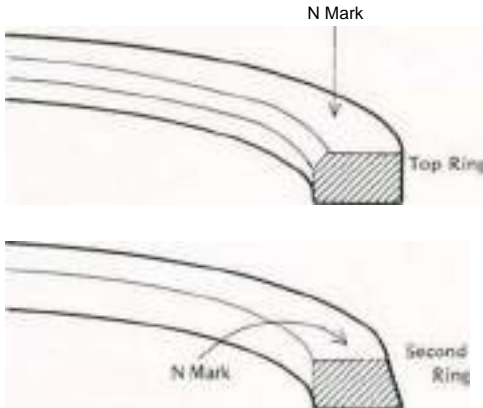

Do not mix up the top and second rings. The top and second rings are not symmetrical and must be installed with the marked side facing up.

Muffler

Spark Arrester Cleaning (U.S. model)

This motorcycle is equipped with a spark arrester approved for off-road use by the U.S. Forest Service. It must be properly maintained to ensure its efficiency. In accordance with the Periodic Maintenance Chart, clean the spark arrester.

| WARNING~|

To avoid burns, wear gloves while cleaning the spark arrester. Since the engine must be run during this procedure, the muffler will become hot.

•Remove the drain plugs on the muffler.



A. Drain Plugs

- In an open area away from combustible materials, start the engine with the transmission in neutral.
- Raise and lower engine speed while tapping on the muffler with a rubber mallet until carbon particles are purged from the muffler.

| WARNING |

Do not run the engine in a closed area. Exhaust gases contain carbon monoxide, a colorless, odorless, poisonous gas. Breathing exhaust gas leads to carbon monoxide poisoning, asphyxiation, and death.

- Stop the engine.
- Install the drain plugs.

Engine Right Side/Left Side

Table of Contents

Exploded View	4-2	Oil Pressure	
Flow Chart — Right Side Parts Removal	4-4	Relief Valve Opening Pressure	
Flow Chart — Left Side Parts Removal	4-5	Oil Pressure Measurement	
Engine Lubrication System	*	Oil Pump	
Service Data	4-6	Removal Point	
Special Tools	*	Installation Points	
Clutch	4-7	Engine Sprocket	4-7
Play Inspection	4-7	Removal	4-7
Play Adjustment		Installation Points	
Clutch Release Removal	4-7	Magneto	
Clutch Release Installation	4-7	Removal	
Clutch Removal		Installation	
Clutch Installation		Balancer Mechanism	4-8
Friction Plate Wear, Damage Inspection		Chain Tension Adjustment	*
Friction or Steel Plate Warp Inspection		Removal Point	4-8
Clutch Spring Free Length Measurement		Assembly Points	4-8
Clutch Housing Finger Inspection Clutch Hub Spline Inspection . .		Balancer Chain Guide Installation. Camshaft Chain Guide Installation Idle Shaft Circlip Installation . . . Balancer Chain Timing Procedure .	
Primary Gear			
Removal or Installation			
Kick Starter (Optional)			
Installation			
Assembly Points			
Engine Lubrication System	4-		
Engine Oil and Filter	4-		
Oil Change	4-		
Oil Level Inspection			
Installation Points of Oil Filter,			

* Refer to Base Manual

4-2 ENGINE RIGHT SIDE/LEFT SIDE

Exploded View

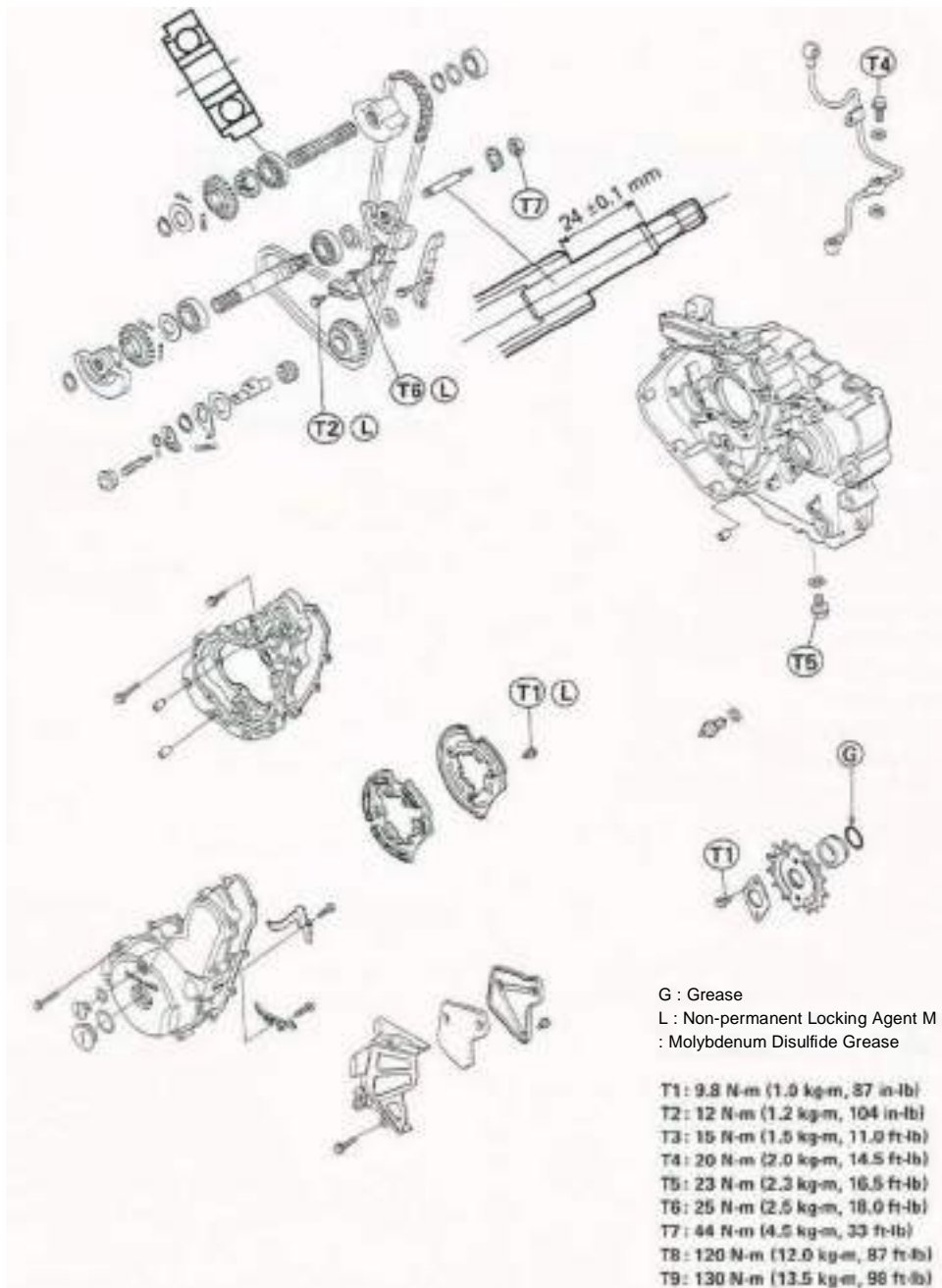

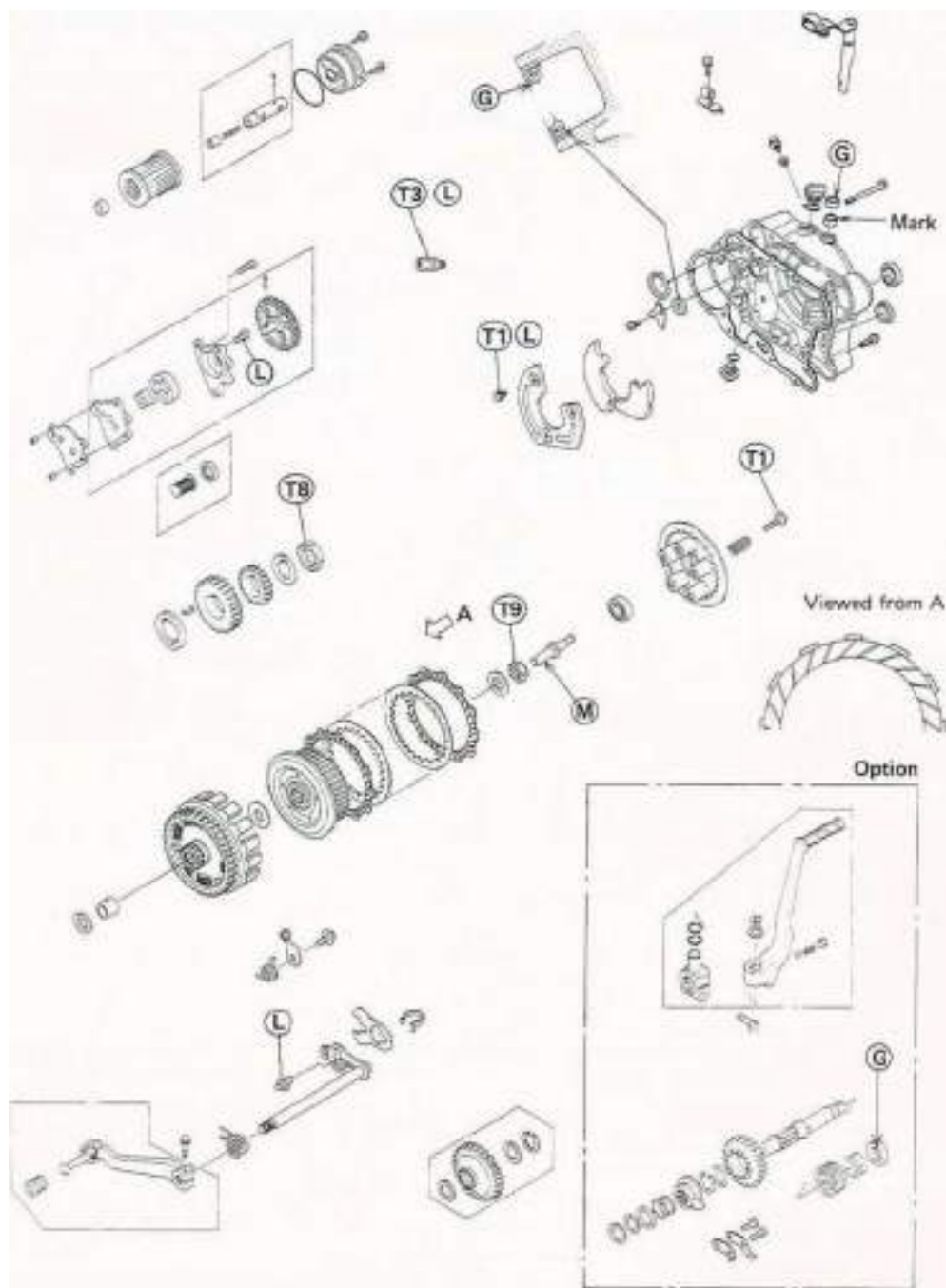

4-4 ENGINE RIGHT SIDE/LEFT SIDE

Flow Chart — Right Side Parts Removals

The following chart is intended to be an aid to proper removal. Select the component you wish to remove and follow the arrows to that point on the chart.

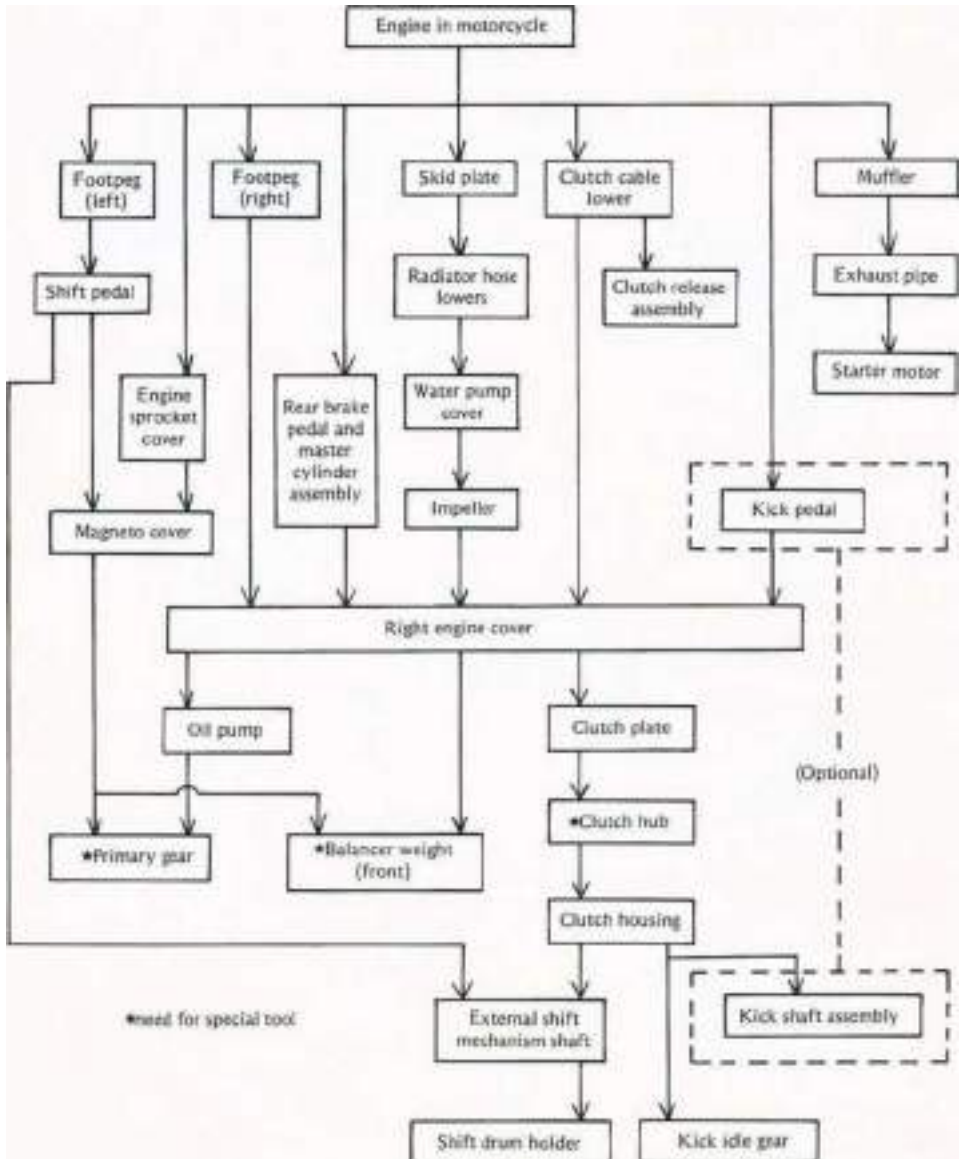

Flow Chart — Left Side Parts Removals

The following chart is intended to be an aid to proper removal. Select the component you wish to remove and follow the arrows to that point on the chart.

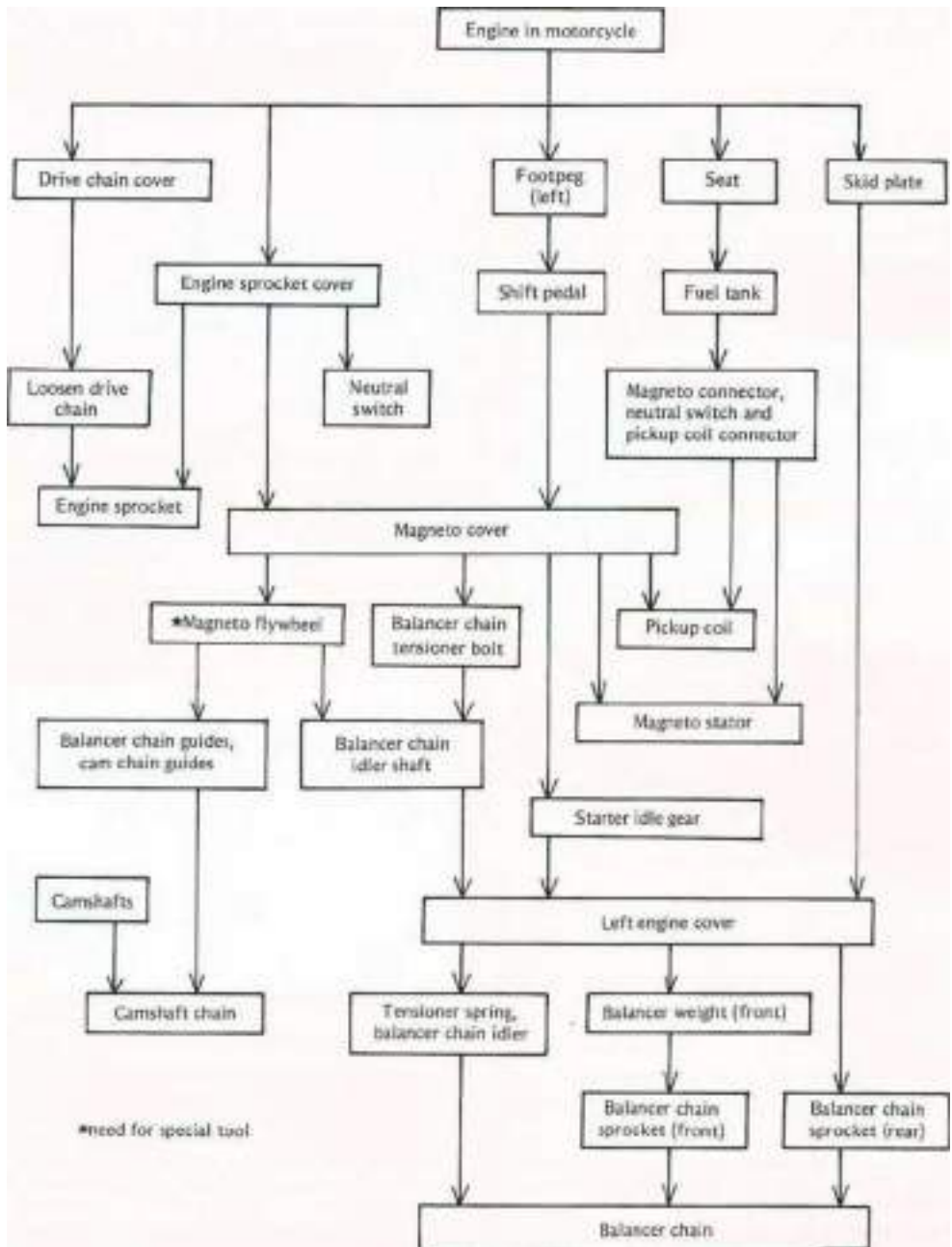

4-6 ENGINE RIGHT SIDE/LEFT SIDE

Service Data

Item	Standard	Service Limit
Clutch:		
Clutch lever play	2 — 3 mm 10 — 15 mm (at lever end)	----
Friction plate thickness	2.9 — 3.1 mm	2.75 mm
Friction, steel plate warp	Less than 0.2 mm	0.3 mm
Clutch spring free length	34.2 mm	33.1 mm
Engine Lubrication System:		
Engine oil: Grade	SE or SF class	----
Viscosity	SAE 10W40, 10W50, 20W40, or 20W50	----
Amount	2.2 L (filter is not removed) 2.5 L (filter is removed)	----
Level	Between upper and lower level lines	----
Relief valve opening pressure	430 - 590 kPa (4.4 - 6.0 kg/cm ² , 63 - 85 psi)	----
Oil pressure	78 - 147 kPa	-----
@4 000 rpm (r/min), 90°C <194°F)	(0.8- 1.5 kg/cm ² , 11 - 21 psi)	

ENGINE RIGHT SIDE/LEFT SIDE 4-7

Clutch

Play Inspection

Refer to the Base Manual, noting the following. •When checking the clutch lever play without the hand cover removal, check the lever play at the lever end.



A. Clutch Lever Play (at lever end): 10 — 15 mm

Clutch Release Removal

Refer to the Base Manual, noting the following. •Before pulling out the clutch release lever and shaft assembly, take out the shaft positioning bolt.



A. Positioning Bolt

Clutch Release Installation

Refer to the Base Manual, noting the following. •Before installing the lever and shaft assembly, check the oil seal and replace it if necessary.

Engine Lubrication System

Engine Oil and Filter

Oil Change

Refer to the Base Manual, noting the following.

•The engine drain plug is installed at the bottom of the crankcase.



A. Drain Plug

Engine Oil

Grade: SE or SF class

Viscosity: SAE 10W40, 10W50 20W40, or 20W50 Amount:

2.2 L (oil filter is not removed)

2.5 L (oil filter is removed)

Engine Sprocket

Removal

Refer to the Base Manual, noting the following. •Loosen the drive chain to remove it from the rear sprocket.

oRemove the cotter pin and loosen the rear axle nut.

CAUTION

oDo not remove the clutch release lever and shaft assembly unless it is absolutely necessary. If removed, the oil seal replacement may be required.

4-8 ENGINE RIGHT SIDE/LEFT SIDE

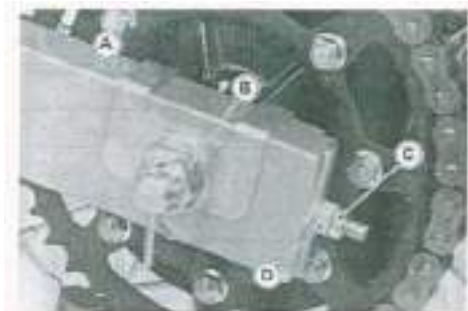

- A. Cotter Pin
B. Locknut
C. Rear Axle
D. Rear Axle

oLoosen the locknuts and back out both left and right chain adjusting nuts evenly, push the rear wheel forward to loose the chain.

Balancer Mechanism

Removal Point

Refer to the Base Manual, noting the following. •Using the magneto holder (special tool: P/N 57001- 1184) to keep the crankshaft and balancer shafts from turning, loosen or tighten the nut of the front right balancer weight.



- A. Water Pump
B. Shaft
C. Nut
D. Right Weight

Assembly Points

Refer to the Base Manual, noting the following. •Tighten the front right balancer weight nut to the specified torque and bend the toothed lockwasher over the nut.

Tightening Torque

Balancer Weight Nut: 44 N-m (4.5 kg-m, 33 ft-lb)

Cooling System

Table of Contents

Exploded	5-
View Service	2
Data	5-
Cooling System	5-
Coolant Deterioration . .	5- ¹
Coolant Level Inspection	54
Coolant Changing	
Coolant Filling	
Air Bleeding	
Visual Leak Inspection	
Cooling System Pressure Testing	
Flushing	
Precaution of Disassembly, Assembly	
Radiator, Radiator Fan	5-4
Removal Points.....	5-4
Radiator Cleaning Points	
Radiator Inspection	
Radiator Cap Inspection	
Radiator Hose, Reserve Tank Hose Inspection.....	
Thermostatic Fan Switch, Water Temperature Sender	
Removal Point	
Installation Point	
Inspection	
Thermostat	
Installation Point	
Thermostat Inspection	
Water Pump, Mechanical Seal.....	5-4
Disassembly	
Inspection	
Assembly Points	5-4

¹Refer to Base Manual

5-2 COOLING SYSTEM

Exploded View

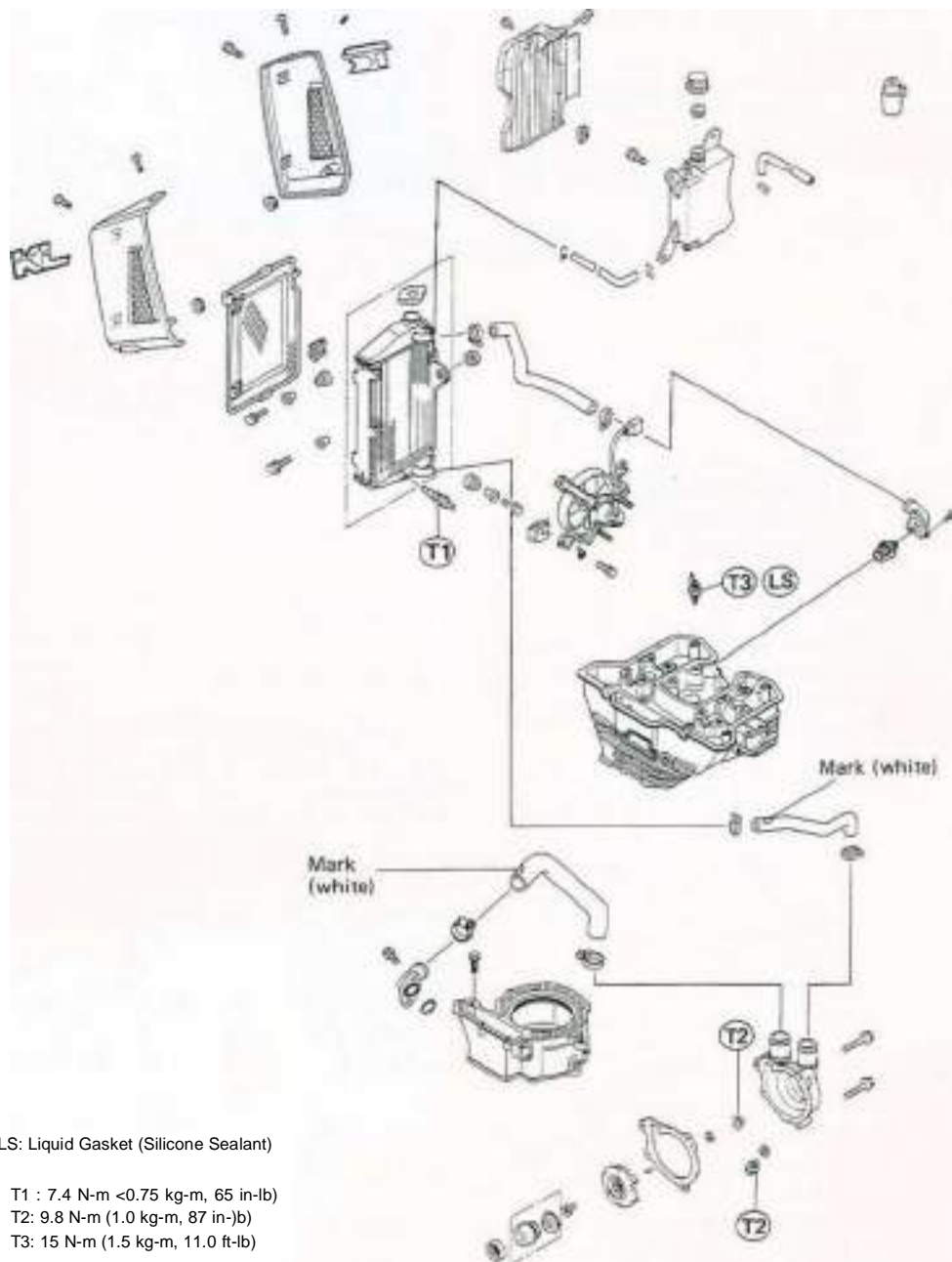

LS: Liquid Gasket (Silicone Sealant)

T1 : 7.4 N-m <0.75 kg-m, 65 in-lb)

T2: 9.8 N-m (1.0 kg-m, 87 in-lb)

T3: 15 N-m (1.5 kg-m, 11.0 ft-lb)

Service Data

Item	Standard
<p>Coolant: Type (recommended)</p> <p>Mixed ratio (provided coolant when shipping)</p> <p>Freezing point (provided coolant when shipping) Total amount Radiator Cap: Relief pressure</p> <p>Thermostat: Valve opening temperature Valve full opening lift</p>	<p>Permanent type of antifreeze (soft water and ethylene glycol plus corrosion and rust inhibitor chemicals for aluminum engines and radiators)</p> <p>Soft water 50%, coolant 50%</p> <p>—35°C (—31° F)</p> <p>1.3 L</p> <p>93 - 123 kPa (0.95 - 1.25 kg/cm², 14-18 psi)</p> <p>69.5 - 72.5°C (157 - 162°F) Not less than 3 mm @85°C (185° F)</p>

Coolant Flow Chart

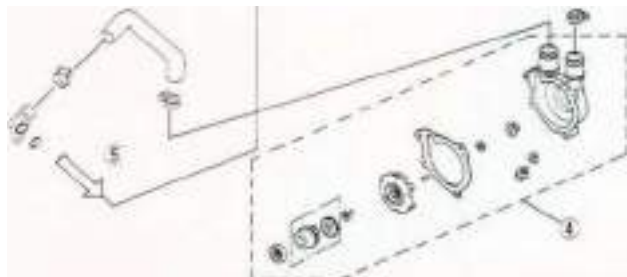
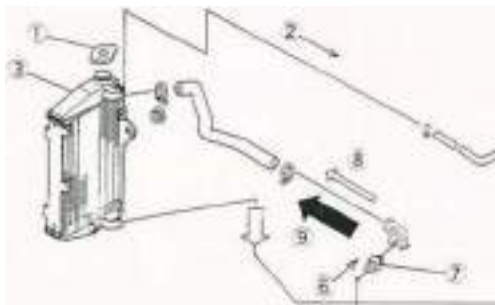

1. Radiator Cap
2. To Reservoir Tank
3. Radiator
4. Water Pump
5. To Cylinder Jacket
6. From Cylinder Head
7. Thermostat
3. Through Thermostat Air Bleeder Hole
- Through Thermostat Valve

5-4 COOLING SYSTEM

Coolant

Coolant Level Inspection

Refer to the Base Manual, noting the following.

- The reserve tank is mounted to the right lower side of the frame head pipe.



A. FULL Mark
B. LOW Mark

C. Tank Cap

°Set the motorcycle on its side stand during the coolant level inspection.

Radiator, Radiator Fan

Removal Points

Refer to the Base Manual, noting the following.

- The radiator is one-piece type and is mounted to the left lower side of the frame head pipe.



A. Radiator
B. Radiator Fan
C. Radiator Fan Switch
D. Radiator Fan Cap

Water Pump, Mechanical Seal

Assembly Points

Refer to the Base Manual, noting the following.

- Impeller shim selection is not necessary. Install only the shim which is 0.8 mm thickness.

Water Pump Installation

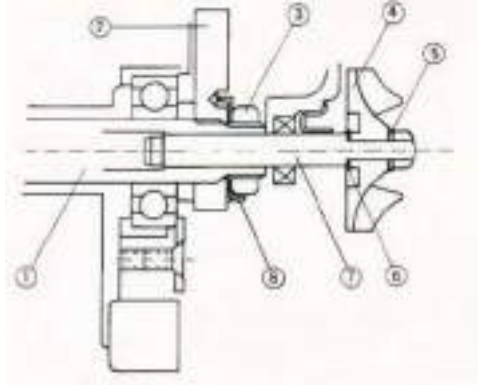

1. Balancer Shaft
2. Right Weight
3. Nut
4. Impeller
5. Washer
6. Shim (0.8 mm thickness)
7. Impeller Shaft
8. Lockwasher

Tightening Torque

Impeller Nut:

9.8 N-m (1.0 kg-m, 87 in-lb)

Engine Removal/Installation

Table of Contents

Exploded View	6-2
Engine Unit	6-3
Removal.....	6-3
Installation.....	6-4
Engine Disassembly	
Precaution.....	
Flow Chart	

'Refer to Base Manual

6-2 ENGINE REMOVAL/INSTALLATION

Exploded View

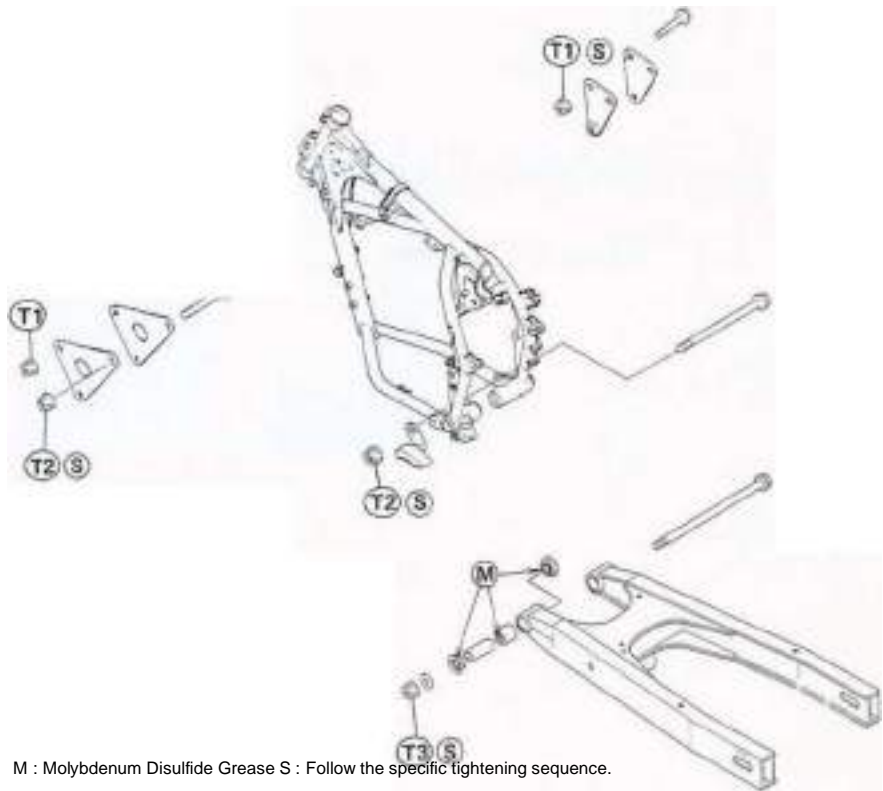

M : Molybdenum Disulfide Grease S : Follow the specific tightening sequence.

T1 : 25 N-m (2.5 kg-m, 18.0 ft-lb)

T2: 44 N-m (4.5 kg-m, 33 ft-lb) T3:

98 N-m (10.0 kg-m, 72 ft-lb)

Engine Unit

Removal

- For later installation convenience, note and record how and where cables, wires, and hoses are routed. They should not be bent sharply, kinked, or twisted.
- Drain the engine's oil (chapter 4) and coolant (chapter 5).
- Remove the parts and free the cables and wiring shown in the chart.
- Place a stand or block under the engine and remove the engine mounting bolts, nuts, and brackets. This chart is designed to aid in determining proper removal sequence. Select the component you wish to remove and follow the arrows to that point on the chart.

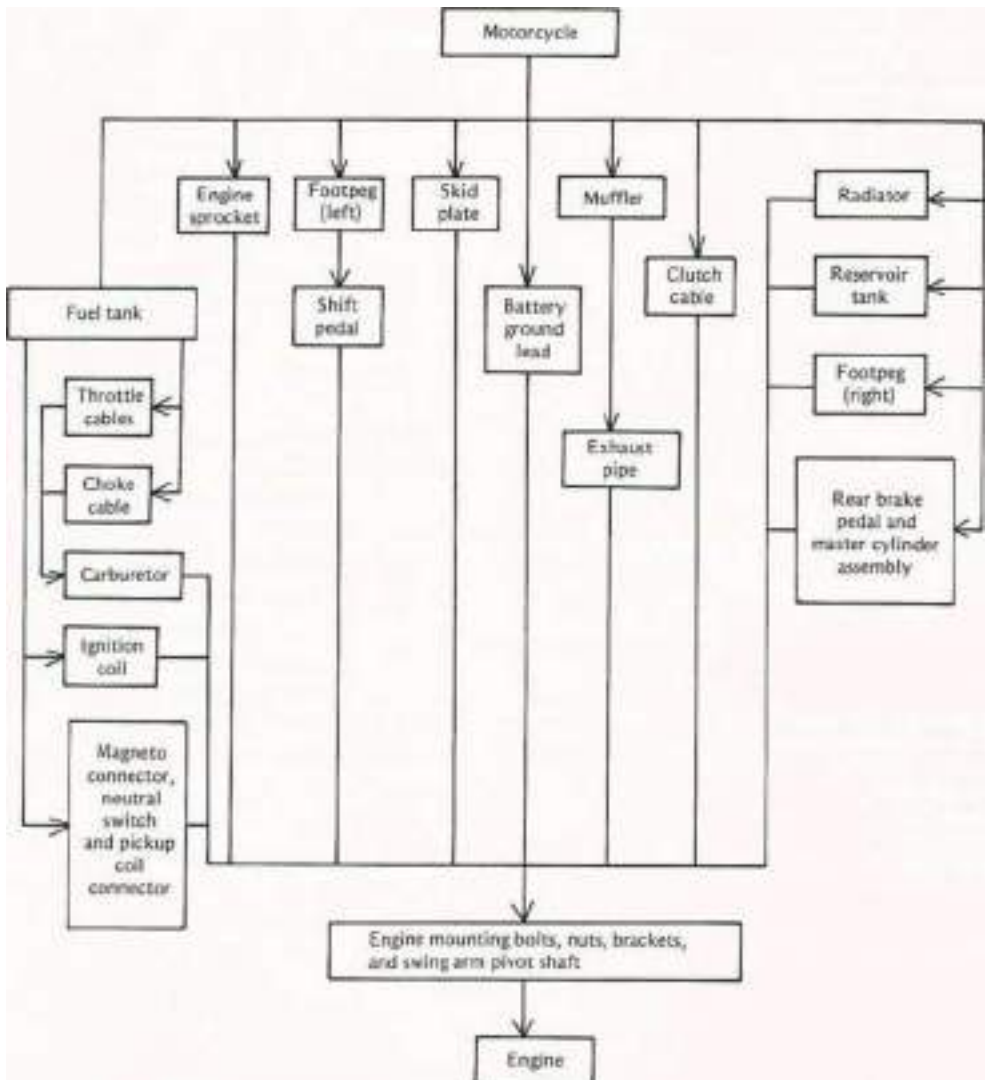

6-4 ENGINE REMOVAL/INSTALLATION

Installation

•Engine unit installation is the reverse of removal. Note the following.

•Tighten the engine mounting bolts, bracket bolts, and swing arm pivot bolt to the specified torque.

Tightening Torque

Engine Mounting Bolts (10 mm):

44 N·m (4.5 kg-m, 33 ft-lb)

Engine Mounting Bolts (8 mm):

23 N-m (2.3 kg-m, 16.5 ft-lb)

Engine Mounting Bracket Bolts (8 mm):

23 N-m (2.3 kg-m, 16.5 ft-lb)

Swing Arm Pivot Bolt:

98 N-m (10.0 kg-m, 72 ft-lb)

Rocker Arm Pivot Bolt:

98 N-m (10.0 kg-m, 72 ft-lb)

Tightening Sequence

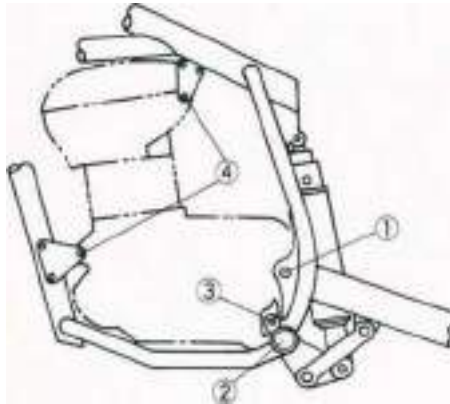

•Fill the engine with engine oil.

•Fill the cooling system with coolant. •Adjust the following.
Throttle Cables Choke Cable Clutch Cable Drive Chain

Engine Bottom End/Transmission

Table of Contents

Exploded View.....	7-
Disassembly Flow Chart.....	2 ,
Service Data.....	7-
Special Tools.....	
Crankcase Splitting	
Crankcase Disassembly Point	
Crankcase Assembly Points	
Rear Balancer Installation.....	
Transmission Disassembly Point	
Transmission Assembly Points	
Crankshaft Installation Points	
Transmission Maintenance.....	
Shift Drum, Shift Fork, Shift Rod, Gear Groove Inspection	
Crankshaft Disassembly.....	
Disassembly Point	
Assembly Points	
Crankshaft Maintenance.....	
Connecting Rod Big End Radial Clearance	
Big End Seizure.....	
Connecting Rod Side Clearance.....	
Crankshaft Runout.....	
Crankshaft Alignment	
Roller Bearing Wear, Damage	

7-2 ENGINE BOTTOM END/TRANSMISSION

Exploded View

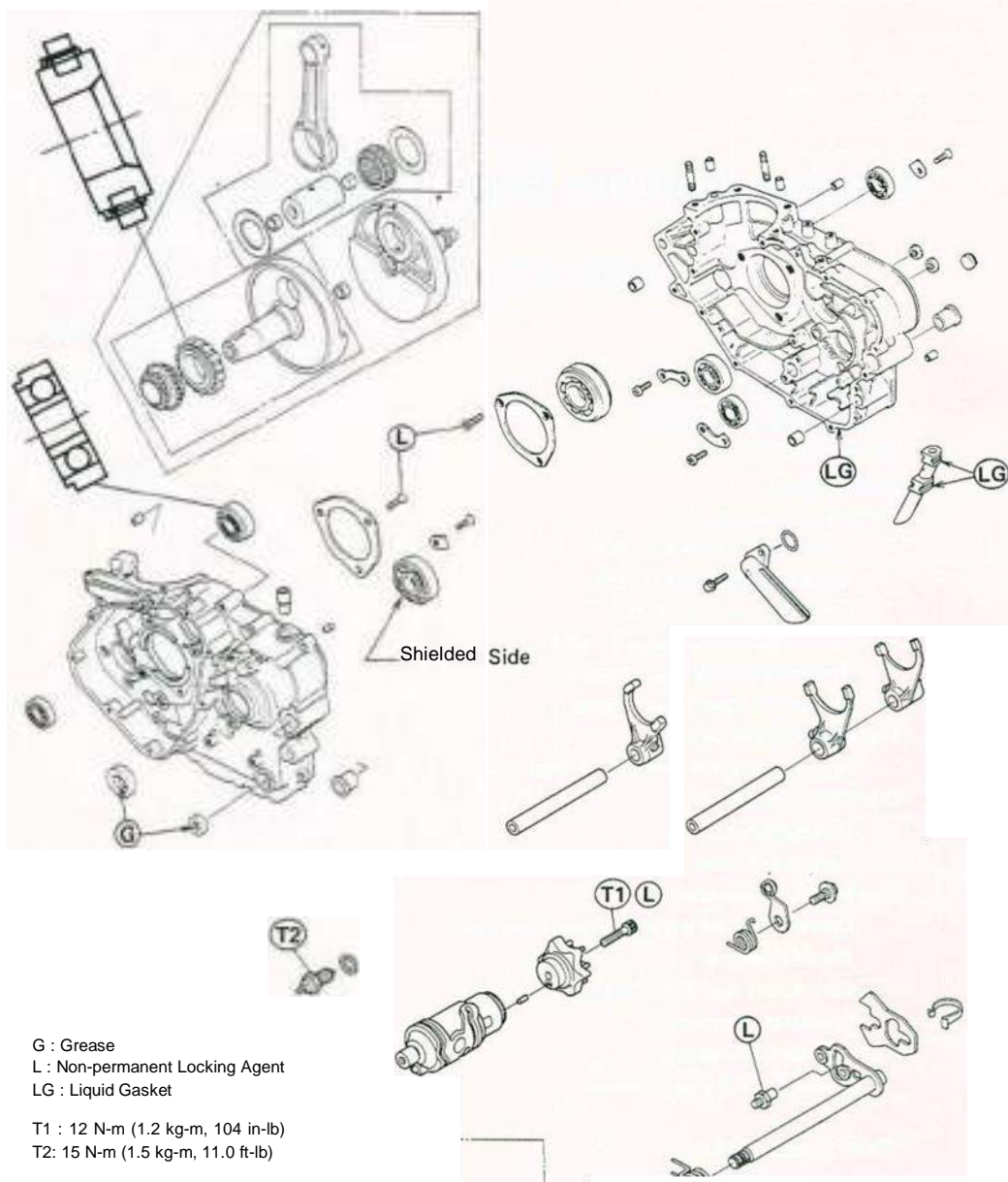

G : Grease
L : Non-permanent Locking Agent
LG : Liquid Gasket

T1 : 12 N-m (1.2 kg-m, 104 in-lb)

T2 : 15 N-m (1.5 kg-m, 11.0 ft-lb)

ENGINE BOTTOM END/TRANSMISSION 7-3

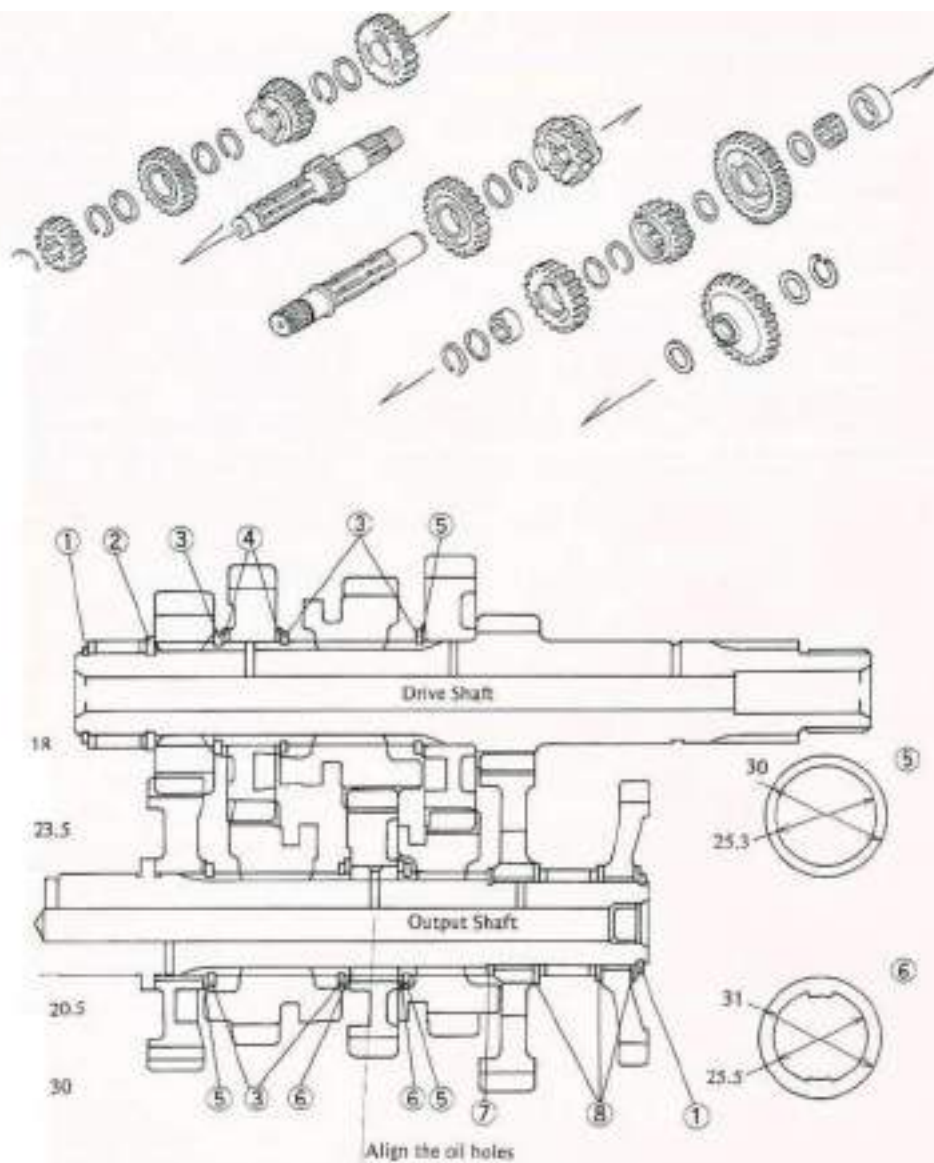

7-4 ENGINE BOTTOM END/TRANSMISSION

Service Data

Item	Standard	Service Limit
Transmission:		
Shift fork finger thickness	4.4 — 4.5 mm	4.3 mm
Gear shift fork groove width	4.55 — 4.65 mm	4.8 mm
Shift fork guide pin diameter	5.9 — 6.0 mm	5.8 mm
Shift drum groove width	6.05 — 6.20 mm	6.3 mm
Crankshaft:		
Connecting rod big end radial clearance	0.008 — 0.020 mm	0.07 mm
Connecting rod side clearance	0.25 — 0.35 mm	0.60 mm
Crankshaft runout: Left half	0.03 mm TIR	0.10 mm TIR
Right half	0.04 mm TI R	0.10 mm TIR
Cold-fitting tolerance between crankpin and flywheel	0.093 -0.122 mm	—

Wheels/Tires

Table of Contents

Exploded View.....	8-2
Service Data.....	8-3
Special Tools.....	
Tires	8-4
Tire Removal.....	
Installation Point of Tires.....	
Adjustment after Tire Installation	8-4
Tire Wear Inspection	
Wheels	8-4
Rear Wheel Removal	8-4
Rear Sprocket Installation	
Rear Wheel Installation Points	8-4
Disc Installation.....	8-4
Front Wheel Balance	8-4
Spokes and Rims	
Spoke Tightness Inspection	
Rim Runout Inspection	
Wheel Bearings	
Bearing Removal	
Installation Points.....	
Wheel Bearing Inspection	
Bearing Lubrication	

8-2 WHEELS/TIRES

Exploded View

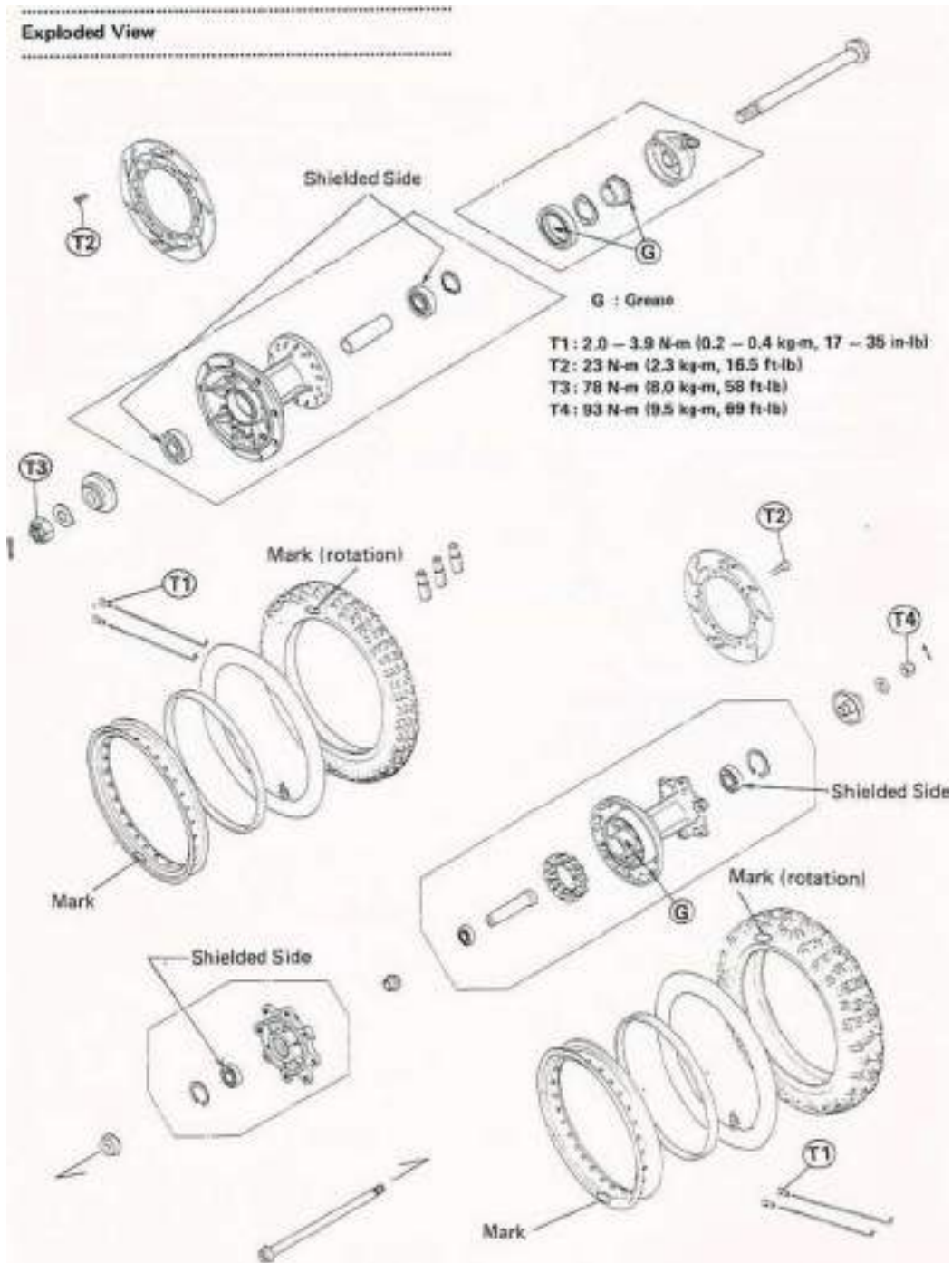

Service Data

	Item	Standard	Service Limit
Tires:			
Standard tire:	Front	90/90-21 54S DUNLOP K750	
	Rear	Ⓢ -A3 ~: DUNLOP TRAIL MAX 130/80-17 65S DUNLOP K750 Ⓢ -A3 ~: DUNLOP TRAIL MAX	
Tire tread depth:	Front	6.4 mm	2 mm
	Rear	8.8 mm	

Tire air pressure:

Front	150 kPa (1.5 kg/cm ² , 21 psi)	
Rear	Up to 97.5 kg (215 lb) load	150 kPa (1.5 kg/cm ² , 21 psi)
	97.5 - 182 kg (215 - 401 lb) load	200 kPa (2.0 kg/cm ² , 28 psi)

Wheels:

Wheel balance Less than 10 g

Balance weights 10 g, 20 g, 30 g

Spokes and

Rims: 2 mm

8-4 WHEELS/TIRES

Tires

Adjustment after Tire Installation

- Check and adjust the following.
 - Tire Air Pressure
 - Wheel Balance (front wheel only)

Rear Wheel Installation Points •Adjust the drive chain slack after installing the rear wheel.

- Tighten the rear caliper mounting bolts to the specified torque.

Tightening Torque

Rear Caliper Mounting Bolts:
25 N-m (2.5 kg-m, 18.0 ft-lb)

- Check the rear brake effectiveness.

Wheels

Rear Wheel Removal

- Remove the rear caliper from the caliper holder with the brake hose connected.



A. Caliper Mounting Bolts B. Caliper Holder

- Remove the cotter pin and take off the rear axle nut.



A. Rear Axle Nut B. Cotter Pin

- Place a stand or block under the motorcycle so that the rear wheel is raised off the ground.
- Pull the rear axle off the wheel and free the drive chain from the rear sprocket.

Disc Installation Points

- Clean the disc and wheel hub mating surfaces of any dirt and foreign particles.
- Mount the brake disc on the wheel so that the marked side faces out.
- Tighten the disc mounting bolts to the specified torque.

Tightening Torque

Disc Mounting Bolts: 23 N-m (2.3 kg-m, 16.5 ft-lb)

- After installing the disc, check the disc runout (see chapter 10).



A. Mark

Front Wheel Balance

To improve stability and decrease vibration at high speed, the front wheel must be kept balanced.

Check and balance the front wheel when required, or when a tire and/or rim is replaced with a new one.

- Raise the front wheel so that it can be spun freely.
- Check that all the spokes are tightened evenly and the rim runout is within the service limit.
- Spin the wheel lightly, and mark the wheel at the top when the wheel stops.

WHEELS/TIRES 8-5



A. Mark at the top.

- Repeat this procedure several times.
- *If the wheel stops of its own accord in various positions, it is well balanced.
- *If the wheel always stops in one position, balance the wheel.
- Temporarily attach a balance weight on the wheel. oAttach a balance weight loosely to the spoke under the marking.



A. Balance Weight

- Rotate the wheel 1/4 turn, and see whether or not the wheel stays in this position.
- *If it does, the correct balance weight is being used.



A. 1/4 turn.

- *If the wheel rotates and the weight goes up, replace the weight with the next heavier size.
- ♦If the wheel rotates and the weight goes down, replace the weight with the next lighter size.
- Repeat these step until the wheel remains at rest after being rotated 1/4 turn.
- Rotate the wheel another 1/4 turn and then another 1/4 turn to see if the wheel is correctly balanced.
- Repeat the entire procedure as many times as necessary to achieve correct wheel balance.
- Install the balance weight firmly on the wheel. oClamp on the balance weight firmly using pliers.

NOTE

Balance weights are available from Kawasaki Dealers in 10, 20, and 30 gram sizes. An imbalance of less than 10 grams will not usually affect running stability. Do not use four or more balance weight (more than 90 g). If the wheel requires an excess balance weight, remove and disassemble the wheel to find the cause.

Final Drive

Table of Contents

Exploded View	9-2
Service Data	9-2
Drive Chain	9-3
Chain Slack Inspection	9-3
Chain Slack Adjustment.....	9-3
Wear Inspection	
Chain Guide Wear	
Lubrication	
Drive Chain Removal.....	9-3
Engine Sprocket.....	

* Refer to Base Manual

9-2 FINAL DRIVE

Exploded View

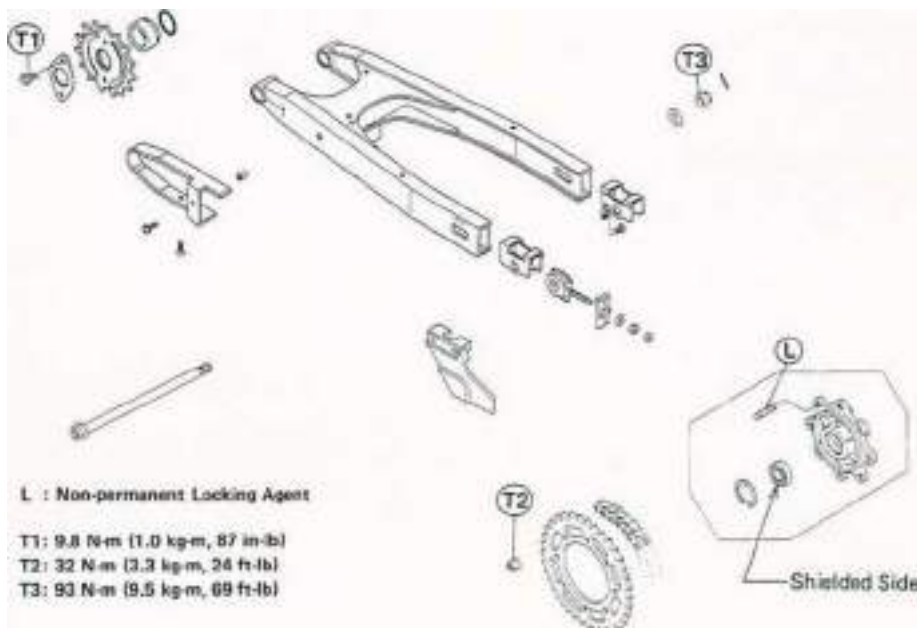
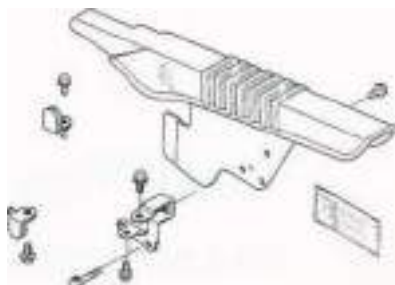

Service Data

Item	Standard	Service Limit
Drive Chain:	EK520LD-0 106 L	50 — 60 mm 323 mm
Standard chain: KL650-A1 ,A2,A3 KL650-A4— KL500	DID. JAPAN. 520V2 106 L	
Chain slack Chain 20-link length	EK520LD-0 108 L 50 — 55 mm 31 7.5 — 31 8.4 mm	

Drive Chain

Chain Slack Inspection

- Stand the motorcycle on its side stand.
- If the drive chain appears dry, lubricate it.
- Route the rear wheel to find the place where the chain is tightest because the chain wears unevenly.
- Measure the vertical movement midway between the sprockets.
- *If the drive chain is too tight or too loose, adjust it so that the chain slack is within the standard value.

Drive Chain Slack

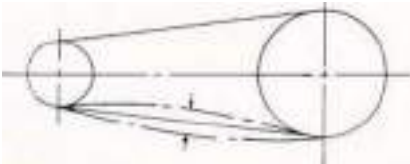

Drive Chain Slack

- Standard: 50 — 55 mm
- Too tight: less than 50 mm
- Too loose: more than 60 mm

Chain Slack Adjustment

- Remove the cotter pin and loosen the rear axle nut.

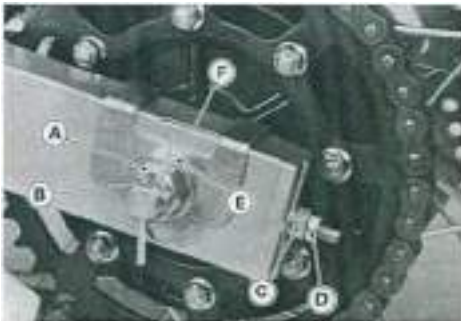

- A. Axle Nut
- B. Cotter Pin
- C. Chain Adjusting Nut
- D. Locknut
- E. Notch
- F. Marks

- Loosen the left and right chain adjusting nut locknuts. *If the chain is too tight, back out the left and right chain adjusting nuts evenly, and kick the wheel forward until the chain is too loose.
- Turn both chain adjusting nuts evenly until the chain has the correct amount of slack. To keep the chain and

wheel properly aligned, the notch on the left chain adjuster should align with the same swing arm mark that the right chain adjuster notch aligns with.

NOTE

oWheel alignment can also be checked using the straightedge or string method.

JA/ARNINGJ

oMisalignment of the wheel will result in abnormal wear, and may result in an unsafe riding condition.

- Tighten the axle nut loosely, and tighten both chain adjusting nuts, but not enough to change the adjustment, and then tighten both locknuts securely.
- Tighten the axle nut to the specified torque.

Tightening Torque

Rear Axle Nut: 93 N-m (9.5 kg-m, 69 ft-lb)

- Rotate the wheel, measure the chain slack again at the tightest position, and readjust if necessary.
- Insert the new cotter pin through the axle nut and axle, and spread its ends.

| WARNING |

oIf the axle nut is not securely tightened and the cotter pin is not installed, an unshaft riding condition may result.

- Check the rear brake effectiveness.

Drive Chain Removal

- Place a stand or block under the motorcycle to raise the rear wheel off the ground.
- After removing the engine sprocket and drive chain from the rear sprocket, remove the swing arm pivot shaft and tie-rod bolt (upper or lower)



A. Swing Arm Pivot Shaft B Tie-rod Bolts

- Pulling back the swing arm, remove the drive chain from the motorcycle.

Brakes

Table of Contents

Exploded View	10-2	Rear Brake Disassembly/Assembly	10-7
Service Data	10-4	Inspection and Adjustment after	
Special Tool	10-4	Installation	10-7
Front Brake Adjustment/Inspection	10-5	Pad Removal	10-7
Brake Lining Wear Inspection		Caliper Removal	10-8
Brake Fluid Level Inspection	10-5	Caliper Installation	10-8
Brake Fluid Change		Caliper Disassembly	10-8
Brake Line Air Bleeding		Caliper Assembly	10-8
Brake Fluid Recommendation		Disc Installation	10-8
Front Brake Disassembly/Assembly	10-5	Master Cylinder Installation Points	10-8
Inspection and Adjustment after		Master Cylinder Disassembly Points	
Installation		Master Cylinder Assembly	10-8
Pad Removal Points	10-5	Brake Maintenance	10-8
Caliper Removal Points		Brake Disc Runout Inspection	10-8
Caliper Installation Points		Brake Light Switch	
Caliper Disassembly Points		Inspection	
Caliper Assembly Points	10-5	Adjustment	
Disc Installation Points		Removal	
Master Cylinder Installation	10-5		
Master Cylinder Disassembly Points . . .	10-6		
Master Cylinder Assembly Points			
Rear Brake Adjustment/Inspection	10-6		
Pedal Position Adjustment	10-6		
Brake Lining Wear Inspection	10-7		
Brake Fluid Level Inspection	10-7		
Brake Fluid Change	10-7		
Brake Line Air Bleeding	10-7		
Brake Fluid Recommendation	10-7		

* Refer to Base Manual

10-2 BRAKES

Exploded View

©

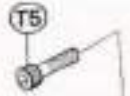

G : Grease

T1 : 5.9 N-m (0.60 kg-m, 52 in-lb) T2 : 7.8 N-m (0.80 kg-m, 69 in-lb) T3 : 8.8 N-m (0.90 kg-m, 78 in-lb) T4 : 18.0 N-m (1.80 kg-m, 18.0 ft-lb)

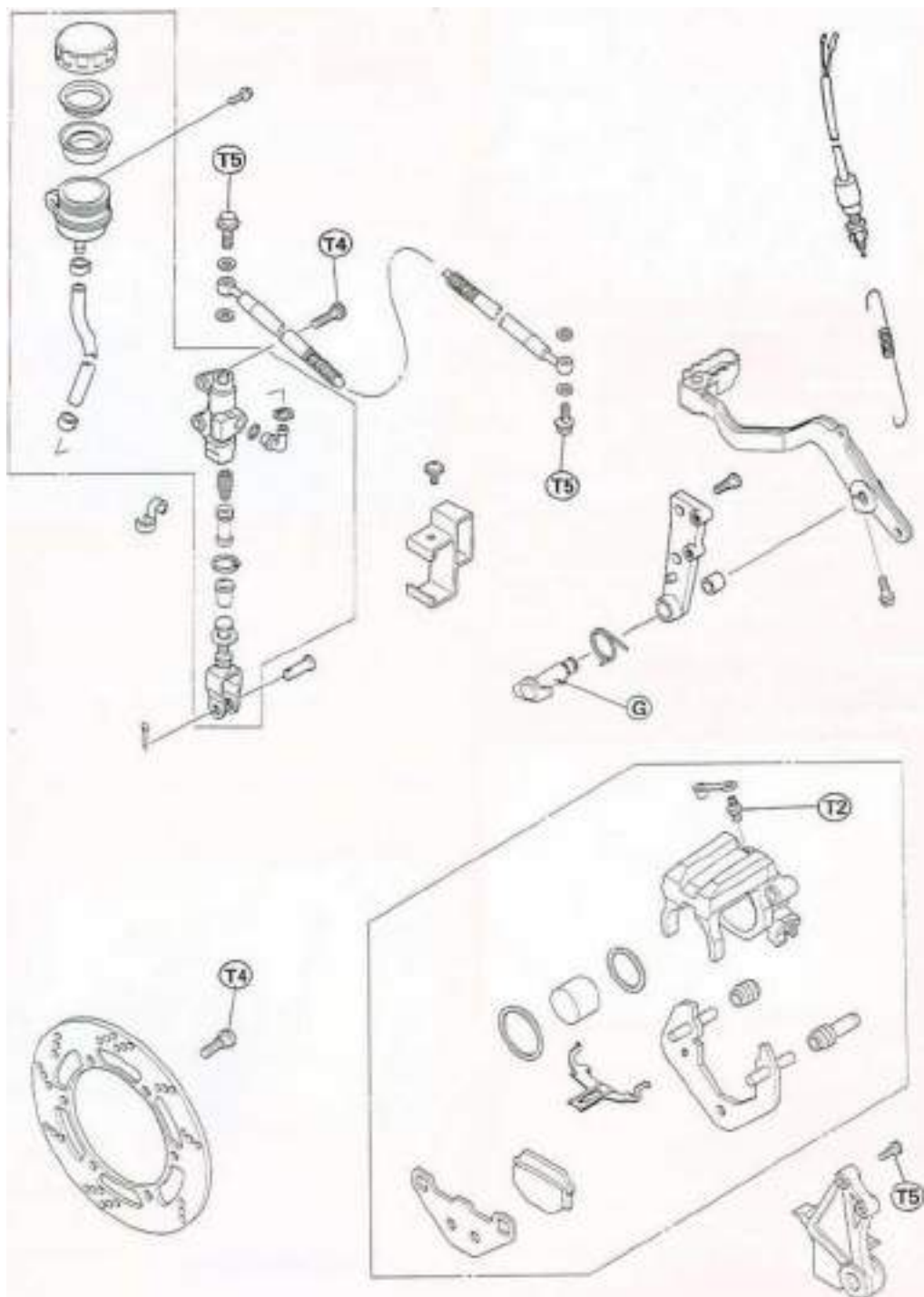

10-4 BRAKES

Service Data

Item	Standard	Service Limit
Brake Fluid:		
Grade	D.O.T.3 or 4	---
Brake Pads:		
Pad lining thickness	4.5 mm	1 mm
Brake Discs:		
Disc thickness: Front	3.8 — 4.1 mm	3.5 mm
Rear	4.8 — 5.1 mm	4.5 mm
Disc runout	Less than 0.2 mm	0.3 mm
Brake Pedal:		
Pedal position	Level with footpeg top	
Brake Light Switch:		
Rear brake light switch operation	ON after about 15 mm pedal travel	---

Special Tool

Circlip Pliers: 57001-143

Front Brake Adjustment/Inspection

Brake Fluid Level Inspection

Refer to the Base Manual, noting the following. •Holding the reservoir horizontally, check that the brake fluid level in the reservoir is higher than the lower level.



A. Lower Level

B. Upper Level



A. Safety Clip

B. Retaining Pin

Caliper Assembly Points

- Apply brake fluid to the outside of the piston and the fluid seal, and push the piston into the cylinder by hand. Take care that neither the cylinder nor the piston skirt scratched.
- Apply a thin coat of PBC (Poly Butyl Cuprysil) grease to the caliper holder shafts and holder holes. (PBC is a special high temperature, water-resistant grease).
- Install the anti-rattle spring in the caliper as shown.

Front Brake Disassembly/Assembly

Pad Removal Points

- Remove the caliper mounting bolts and lift the caliper off the disc.



A. Caliper Mounting Bolts



A. Anti-rattle Spring

- Remove the safety clip and pull out the pad retaining pin.

Master Cylinder Installation

- Refer to the Base Manual, noting the following.
- The master cylinder clamp must be installed with the UP mark pointing up.

10-6 BRAKES



A. UP Mark

Master Cylinder Disassembly Points

•Using the circlip pliers (special tool: P/N 57001-143), remove the circlip and pull the piston and spring out of the cylinder.

Front Master Cylinder

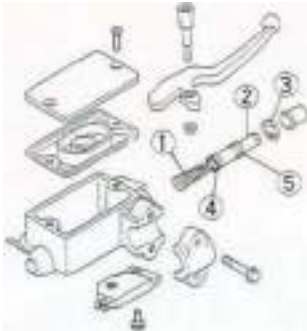

- 1 Spring
- 2 Piston
- 3 Circlip
- 4 Primary Cup
- 5 Secondary Cup

CAUTION

Do not remove the primary and secondary cups from the piston since removal will damage them.

Rear Brake Adjustment/Inspection

Pedal Position Adjustment

•When the brake pedal is in its rest position, it should be at the position specified.

Brake Pedal Position

Standard: Level with footpeg top



A. Footpeg

B. Brake Pedal

•If it is not, adjust the brake pedal position as follows.
 •Remove the master cylinder bracket bolts.



- A. Master Cylinder Bracket Bolts
- B. Locknut
- C. Clevis
- D. Adjusting Nut
- E. Cotter Pin
- F. Clevis Pin

NOTE

If the pedal position cannot be adjusted by turning the clevis, the brake pedal may be deformed or incorrectly installed.
 If the brake rod protrusion is 3.0 — 3.5 mm below the nut, the pedal will be at the position specified.

Brake Rod Protrusion

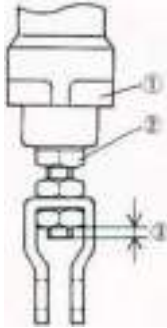

1. Master Cylinder
2. Adjusting Nut
3. Rod Protrusion

•Check the brake pedal position, and readjust it if necessary.
 •Install the removed parts and tighten the locknut. •Check the brake light switch and adjust if necessary.

Brake Lining Wear Inspection

Refer to the Front Brake Adjustment/Inspection section in the Base Manual.

Brake Fluid Level Inspection

Refer to the Front Brake Adjustment/Inspection section in the Base Manual, noting the following. •Holding the reservoir horizontally, check that the brake fluid level in the reservoir is between the upper and lower lines.



- A. Reservoir
- B. Upper Level
- C. Lower Level

Brake Fluid Change

Refer to the Front Brake Adjustment/Inspection section in the Base Manual, noting the following.

»Press down the brake pedal instead of squeezing the brake lever to apply the rear brake.

Brake Line Air Bleeding

Refer to the Front Brake Adjustment/Inspection section in the Base Manual, noting the following.

•Press down the brake pedal instead of squeezing the brake lever to apply the brake.

Brake Fluid Recommendation

Refer to the Front Brake Adjustment/Inspection section in the Base Manual.

Rear Brake Disassembly/Assembly

•Observe the WARNING and CAUTION in the Brake Fluid Recommendation.

Inspection and Adjustment after Installation Refer to the Front Brake Disassembly/Assembly section in the Base Manual, noting the following.

•Check the rear brake for good braking power, no brake drag, and no fluid leakage.

1 warning!

ODO do not attempt to drive the motorcycle until a full brake pedal is obtained by pumping the brake pedal until the pads are against the disc. The brake will not function on the first application of the pedal if this is not done.

Pad Removal

Refer to the Front Brake Disassembly/Assembly section in the Base Manual, noting the following.



- A. Rear Caliper Mounting Bolts

10-8 BRAKES

Caliper Removal

Refer to the Front Brake Disassembly/Assembly section in the Base Manual, noting the following.

- Use the brake pedal instead of using the brake lever to remove the caliper piston.

Caliper Installation

Refer to the Front Brake Disassembly/Assembly section in the Base Manual.

Caliper Disassembly

Refer to the Front Brake Disassembly/Assembly section in the Base Manual.

Caliper Assembly.

Refer to the Front Brake Disassembly/Assembly section in the Base Manual.

Disc Installation

Refer to the Front Brake Disassembly/Assembly section in the Base Manual.

Master Cylinder Installation Points •Discard the used flat washers, and install a new washer on each side of the brake hose fittings.

- Check and adjust the brake pedal position.

Master Cylinder Disassembly Points •Using the circlip pliers (special tool: P/N 57001-143), remove the circlip and pull the piston and spring out of the cylinder.

Rear Master Cylinder

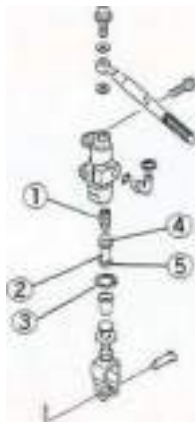

1. Spring
2. Piston
3. Circlip
4. Primary Cup
5. Secondary Cup

[CAUTION]

DO not remove the primary and secondary cups from the piston since removal will damage them.

Master Cylinder Assembly

Refer to the Front Brake Disassembly/Assembly section in the Base Manual.

Brake Maintenance

Brake Disc Runout Inspection

A warped disc will cause the brake pads to drag on the disc and will wear down both the pads and disc quickly. Dragging will also cause overheating and poor braking efficiency.

- Raise the wheel off the ground.

- oTurn the handlebar fully to one side if it is the front wheel.

- Set up a dial gauge against the brake disc and rotate the wheel to measure the runout. The difference between the highest and lowest dial reading is the amount of runout.

- *If runout is beyond the service limit, replace the brake disc.

Suspension /Steering

Table of Contents

Exploded	11-
View Service	2
Data ..	11-
Special Tools.	
Steering Inspection	
Steering Adjustment.....	
Stem Bearing Lubrication	
Grease Seal Deterioration, Damage	
Stem Bearing Removal	
Stem Bearing, Grease Seal Installation	
Steering Stem Installation	
Adjustment after Installation	
Front Fork.....	11-6
Air Pressure Adjustment	
Fork Oil Level	11-6
Fork Oil Changing	11-6
Fork Disassembly	11-6
Fork Assembly	11-6
Inner Tube Inspection	
Guide Bush Inspection	
Guide Bush Replacement	11-6
Uni-trak.....	11-6
Spring Preload Adjustment	11-6
Damper Adjustment	11-7
Rear Shock Removal	11-7
Rear Shock Scrapping	
Rear Shock Installation Point.....	11-7
Uni-trak Sleeve Inspection	
Uni-trak Needle Bearing Inspection	
Uni-trak Lubrication.....	

* Refer to Base Manual

11-2 SUSPENSION/STEERING

Exploded View

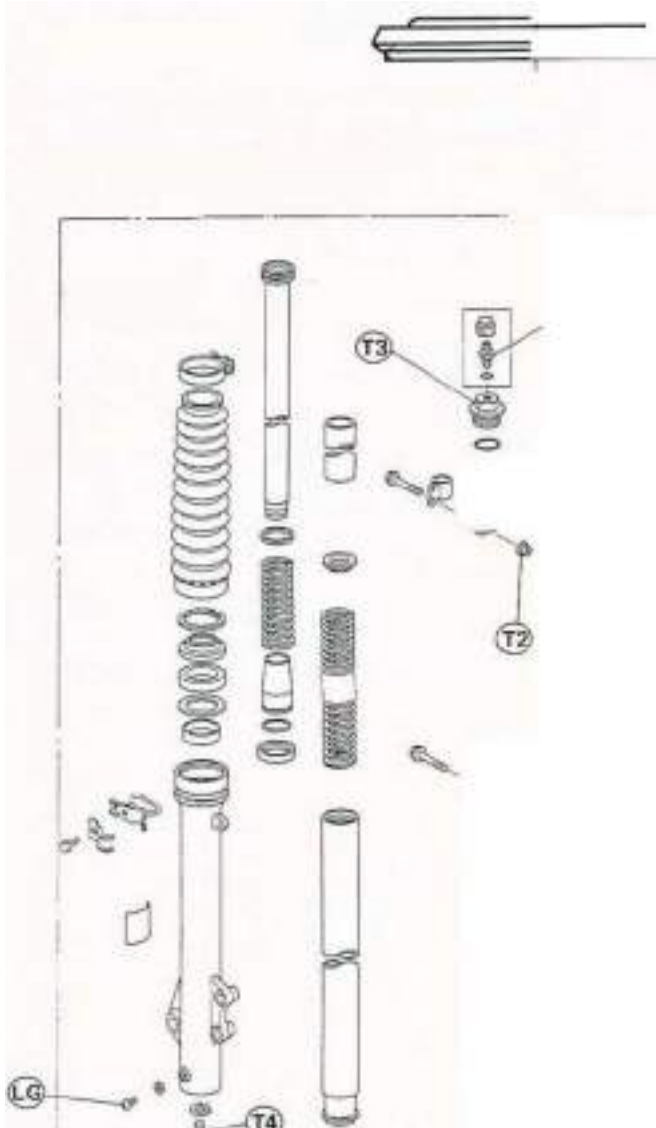

SUSPENSION/STEERING 11-3

G : Grease

L : Non-permanent Locking Agent

LG : Liquid Gasket

M : Molybdenum Disulfide Grease

T1: 12 N-m (1.2 kg-m, 104 in-lb)

T2: 25 N-m (2.5 kg-m, 18.0 ft-lb)

T3: 29 N-m (3.0 kg-m, 22 ft-lb)

T4: 39 N-m (4.0 kg-m, 29 ft-lb)

T5: 59 N-m (6.0 kg-m, 43 ft-lb)

T6: 98 N-m (10.0 kg-m, 72 ft-lb)

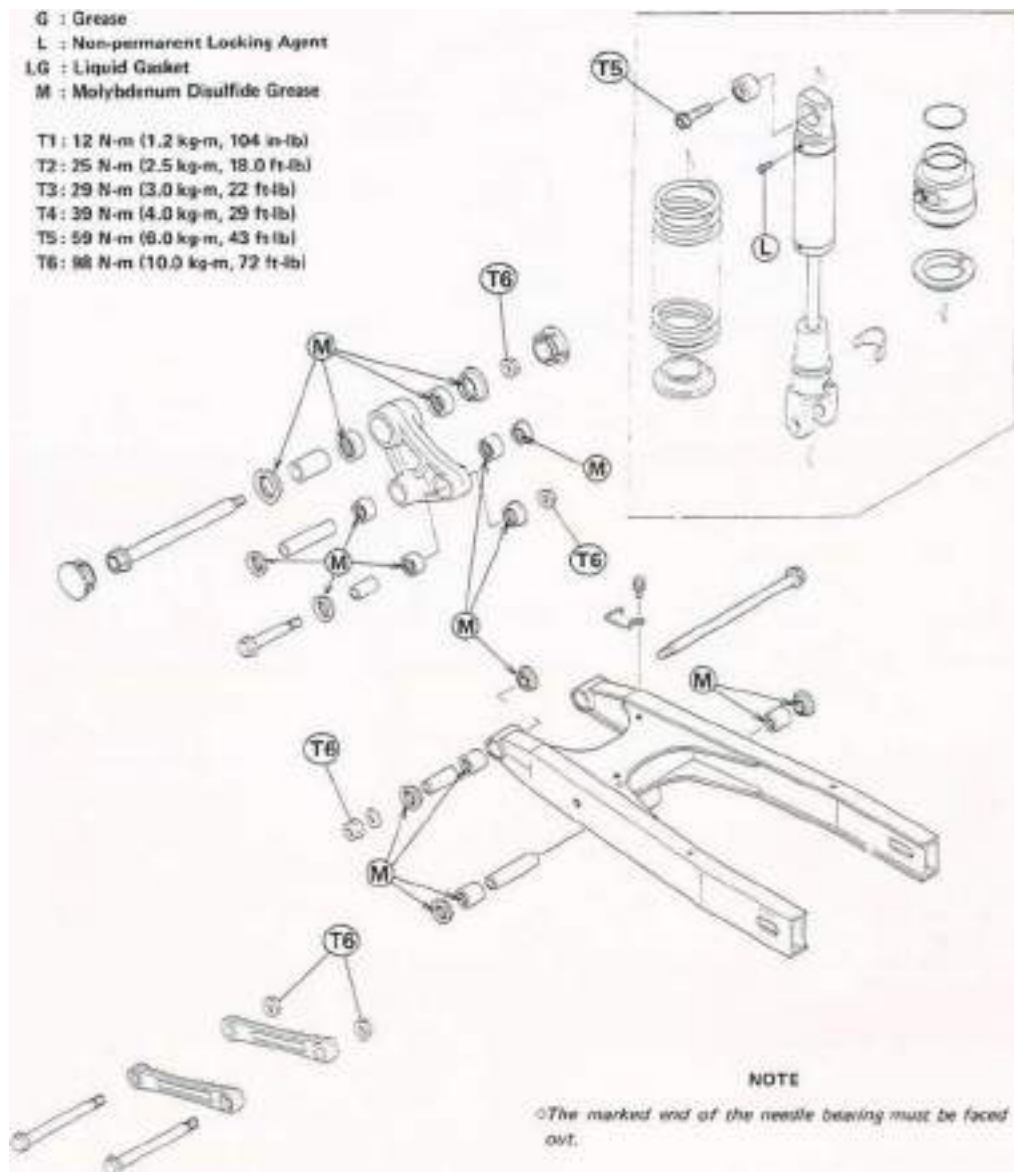

11^ SUSPENSION/STEERING

Service Data

Item	Standard	Service Limit
Front Fork: Air pressure Oil viscosity Oil amount (par side) Oil level (fully compressed)	0 (atmospheric pressure) SAE 10W20 420 ±4 mL 190 ±2 mm (from top of inner tube)	--
Rear Shock Absorber: Spring preload adjuster Damper adjuster	No. 1 of 5 positions No. 1 of 4 positions	--
Uni-trak Sleeves: Sleeve outside diameter: Swing arm pivot Rocker arm pivot Tie-rod ends Rear Shock lower end	19.979 - 20.000 mm 27.979 - 28.000 mm 19.979 - 20.000 mm 19.979 - 20.000 mm	19.95 mm 27.95 mm 19.95 mm 19.95 mm

Special Tools

Stem Bearing Driver: 57001-137
Adapter: 57001-1074



Handle: 57001-183
Adapter: 57001-1057



Driver Press Shaft: 57001-1075
Drivers: 57001-1076, 1106

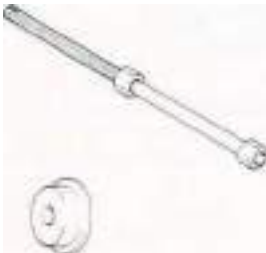

o:

Stem Nut Wrench: 57001-1100



Oil Seal Driver: 57001-1104



NOTE

oFollowing tools can be used for front fork servicing instead of using the oil seal driver (P/N 57001- 1104).

Fork Outer Tube Weight: 57001-1218



Fork Oil Seal Driver: 57001-1219



Stem Bearing Remover: 57001-1107



11-6 SUSPENSION/STEERING

Front Fork

Fork Oil Level

Refer to the Base Manual, noting the following.

Front Fork Oil Level

190 ±2 mm below the top end of the inner tube

Fork OH Changing

Refer to the Base Manual, noting the following.

Front Fork Oil

Rating: Kayaba G-10

Viscosity: SAE 10W20

Amount per side:

When changing oil: 355 mL After

disassembly and completely dry:

420 ±4 mL

Fork Disassembly

Refer to the Base Manual, noting the following.

•When separating the inner tube from the outer tube, the fork outer tube weight (special tool: P/N 57001-1218) can be used to separate them instead of using the driver (special tool: P/N 57001-1104). Perform the following.

oMount the weight (special tool) on the top of the outer tube, by fitting the step of the weight to the top corner of the outer tube.

oHolding the inner tube by hand in a vertical position, stroke the outer tube several times and pull it down.

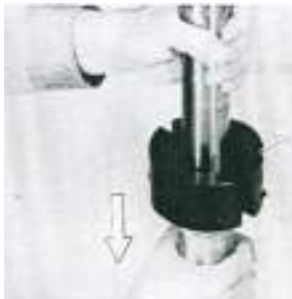

Fork Assembly

Refer to the Base Manual, noting the following.

•When installing the guide bush and oil seal at the outer tube top, the fork oil seal driver (special tool: P/N 57001-1219) can be used to install them. Instead of using the driver (special tool: P/N 57001-1104). See Guide Bush Replacement.

Guide Bush Replacement

Refer to the Base Manual, noting the following.

•When installing the guide bush and oil seal at the outer tube top, the fork oil seal driver (special tool: P/N 57001-1219) can be used to install them instead of using the driver (special tool: 57001-1104). Perform the following.

oInstall the guide bush (with a used guide bush or washer on it) by tapping the used guide bush or washer with the driver until it stops. The slit of the bush must be faced toward the left or right.

Guide Bush Installation

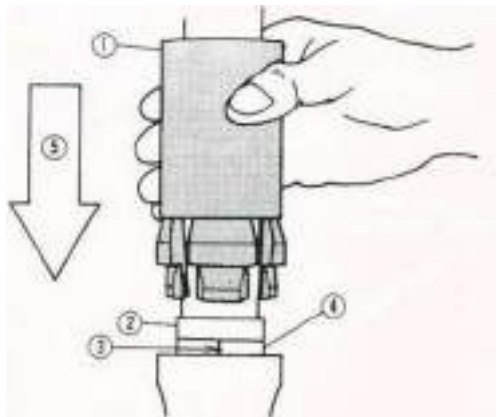

1. Driver: 57001-1219
2. Used Guide Bush.
3. Slit (toward the left or right)
4. New Guide Bush
5. Tap

Uni-trak

Spring Preload Adjustment

The spring preload adjuster on the rear shock absorber has 5 positions so that the spring force can be

adjusted for different riding conditions.

A. Fork Outer Tube Weight: 57001-1218

- Using a socket wrench, turn the spring preload adjuster as required.
- oFor Californian vehicles, remove the liquid/vapor separator from its bracket.



A. Spring Preload Adjuster



- A. Carburetor Air Duct Clamp
- B. Reservoir Mounting Bolt
- C. Footpeg Bracket Bolts
- D. Rear Frame Upper Bolt (remove)
- E. Rear Frame Lower Bolt (loosen)

Setting Table for Spring Preload and Damper Adjusters

Riding Condition	An average- build rider or a rider with load	A rider and a passenger	A rider and a passenger with load
Spring preload	ⓐ or 2	@ or 3	ⓐ, 4, or 5
Damper	(D or n	(g)orm	ⓐ or m

O: Standard setting (number) is identified with a circle marking.



A. Rear Frame

B. Rear Shock Absorber

Damper Adjustment

- Refer to the Base Manual, noting the following.
- See Setting Table in the Spring Preload Adjustment paragraph to adjust the damper adjuster.

Rear Shock Removal •Remove the following.

- Side Covers
- Seat
- Fuel Tank
- Battery
- Muffler
- Remove the mounting bolt of the rear brake master cylinder reservoir.
- Remove the rear right footpeg bracket bolts.
- Loosen the clamp of the carburetor air duct. •Disconnect the main harness connectors, and remove the clamps to free rear frame from the harness.
- Loosen the rear frame lower bolts and remove the upper bolts.
- Tilt the rear frame backwards.

- Loosen the upper and lower shock absorber mounting nuts. Do not remove them yet.
- Place a stand or block under the motorcycle so that the rear wheel off the ground.
- Remove the rear shock absorber mounting bolts and nuts, take out the rear shock absorber.

Rear Shock Installation Point

- Tighten the following bolts to the specified torque.

Tightening Torque

Rear Shock Mounting:

Upper: 59 N-m (6.0 kg-m, 43 ft-lb)

Lower: 98 N-m (10.0 kg-m, 72 ft-lb)

Rear Frame Mounting Bolts:

25 N-m (2.5 kg-m, 18.0 ft-lb)

Controls / Instruments

Table of Contents

Exploded View	12-2
Service Data	12-4
Special Tool.....	12-4
Choke Lever	*
Adjustment.....	*
Throttle Grip	12-5
Inspection	12-5
Adjustment.....	12-5
Clutch	See chapter 4
Meter Unit	12-6
Removal.....	12-6
Disassembly	*
Speedometer	*
Speedometer Disassembly	*
Lubrication	*
Handlebar	*
Installation	*



*Refer to Base Manual

12-2 CONTROLS/INSTRUMENTS

Exploded View

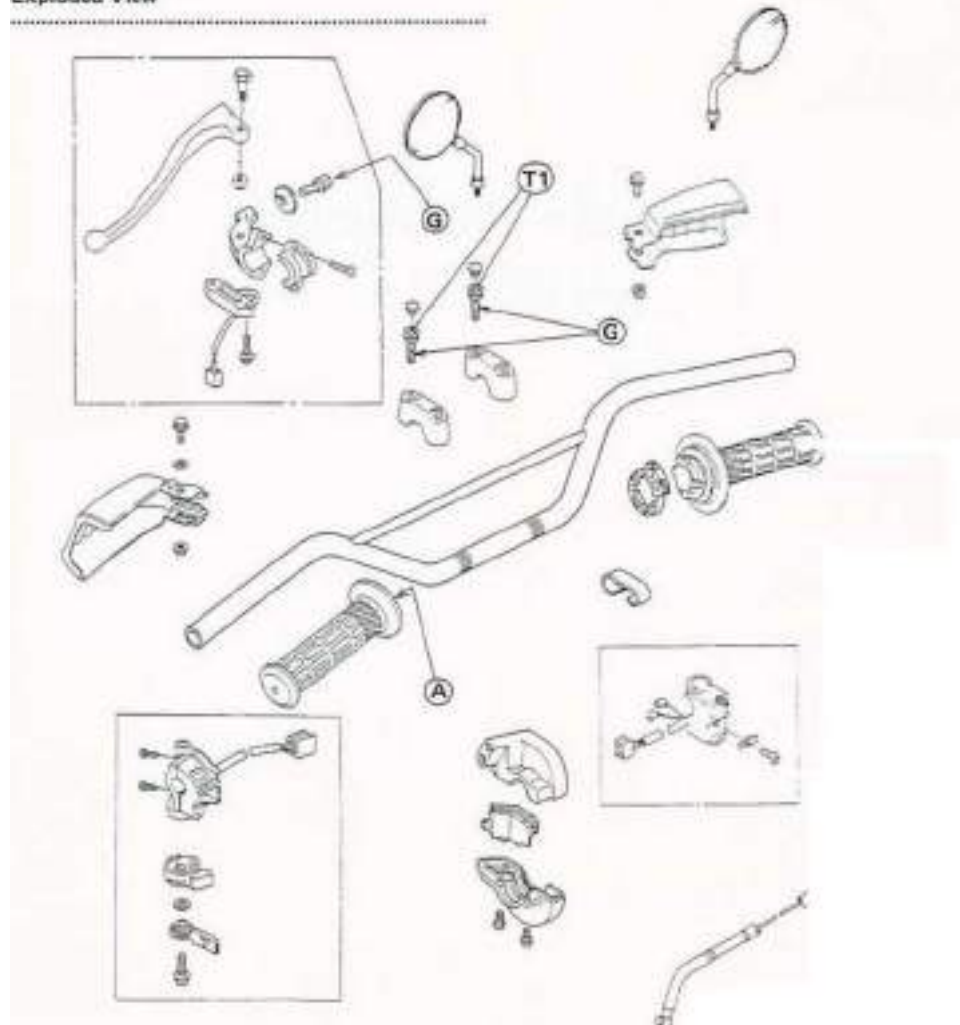

A : Adhesive

CONTROLS/INSTRUMENTS 12-3

12-4 CONTROLS/INSTRUMENTS

Service Data

Item	Standard
Choke Lever: Choke cable free play Throttle Grip: Throttle grip free play Clutch: Clutch lever free play	2 — 3 mm 2 — 3 mm 2 — 3 mm 10 — 15 mm (at lever end)

Throttle Grip

There are two throttle cables: an accelerator cable for opening the throttle valve, and a decelerator cable for closing it.

If the throttle grip has excessive free play due to cable stretch or misadjustment, there will be a delay in throttle response. Also, the throttle valve may not open fully at full throttle.

On the other hand, if the grip has no play, the throttle will be hard to control, and the idle speed will be erratic. Check the throttle grip play periodically in accordance with the Periodic Maintenance Chart, and adjust the play if necessary.

Inspection

•Check that there is 2 — 3 mm throttle grip free play when lightly turning the throttle grip back and forth.

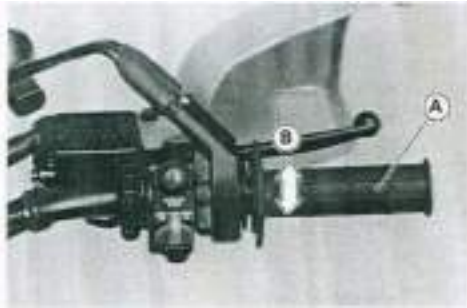

A. Throttle Grip B. 2 — 3 mm

•With the throttle grip closed, check that the decelerator inner cable is tight by touching it at the lower end.



A. Decelerator Inner Cable

*If the throttle grip free play is incorrect or the decelerator inner cable is loose with the throttle closed, adjust the throttle grip.

Adjustment

- Loosen the locknuts, and screw both throttle cable adjusting nuts in fully at the upper ends of the throttle cables to give the throttle grip plenty of play.
- With the throttle grip completely closed, turn out the decelerator cable adjusting nut until the inner cable just becomes tight.
- Tighten the locknut.



A. Accelerator Cable Adjusting Nut C. Locknuts
B. Decelerator Cable Adjusting Nut

- Turn the accelerator cable adjusting nut until the correct throttle grip free play is obtained.
- Tighten the locknut.

NOTE

if the throttle cables cannot be adjusted by using the cable adjuster nuts at the upper ends of the throttle cables, use the cable adjusters at the lower ends of the throttle cables. Do not forget to securely tighten the adjuster locknuts after adjustment.



A. Cable Adjusters B. Locknuts

WARNING

Be sure the upper ends of the outer cables are fully seated in their adjusting nuts, or they could slip into place later, creating enough grip play to prevent

12-6 CONTROLS/INSTRUMENTS

throttle operation, resulting in a hazardous riding conditions.

- Start the engine.
- Turn the handlebar from side to side while Idling the engine.
- If Idle speed varies, the throttle cables may be poorly routed or they may be damaged.
- Correct any problem before operating the motorcycle.

WARNING^

oOperation with an improperly adjusted, incorrectly routed, or damaged cable could result in an unsafe riding condition.

- Disconnect the 9-pin meter connector.
- Remove the meter mounting nuts and the speedometer cable nut, and take off the meter unit.



A. Meter Mounting Nuts C. Meter 9-pin Connector
B. Speedometer Cable Nut (White)

Meter Unit

Removal

- Remove the headlight cover and connector cover.



A. Headlight Cover B. Screws



A. Connector Cover B. Screws

Frame

Table of Contents

Exploded View	13-2
Disassembly Flow Chart — Chassis	13-4

13-2 FRAME

Exploded View

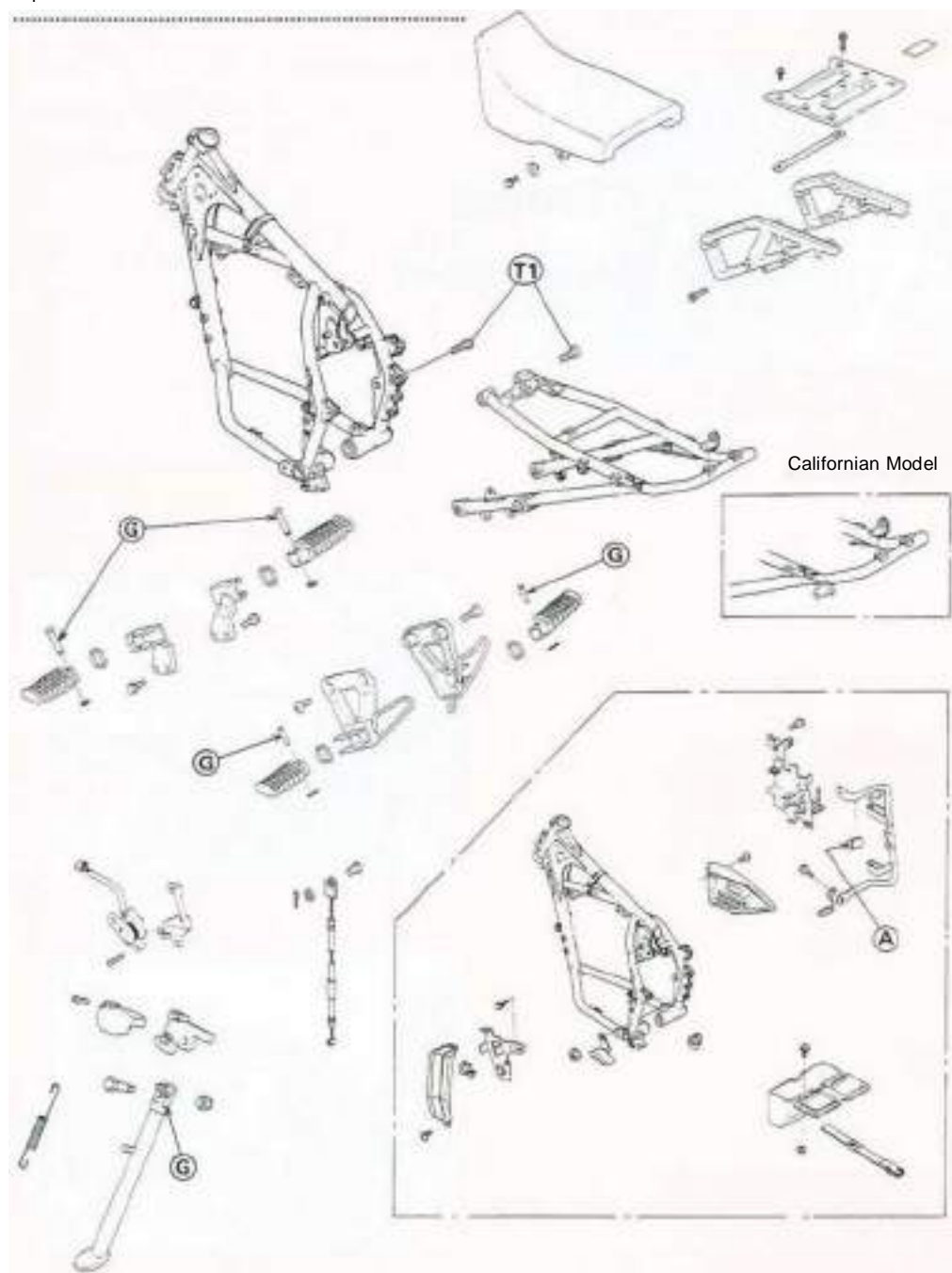



A : Adhesive G : Grease

T1 : 25 N-m (2.5 kg-m, 18.0 ft-lb)



13-4 FRAME

Disassembly Flow Chart — Chassis

This chart is designed to aid in determining proper removal sequence. Select the component you wish to remove and follow the arrows to that point on the chart.

•Set the motorcycle up on a stand or jacks so that it is stable during the removal and installation operations.

Motorcycle

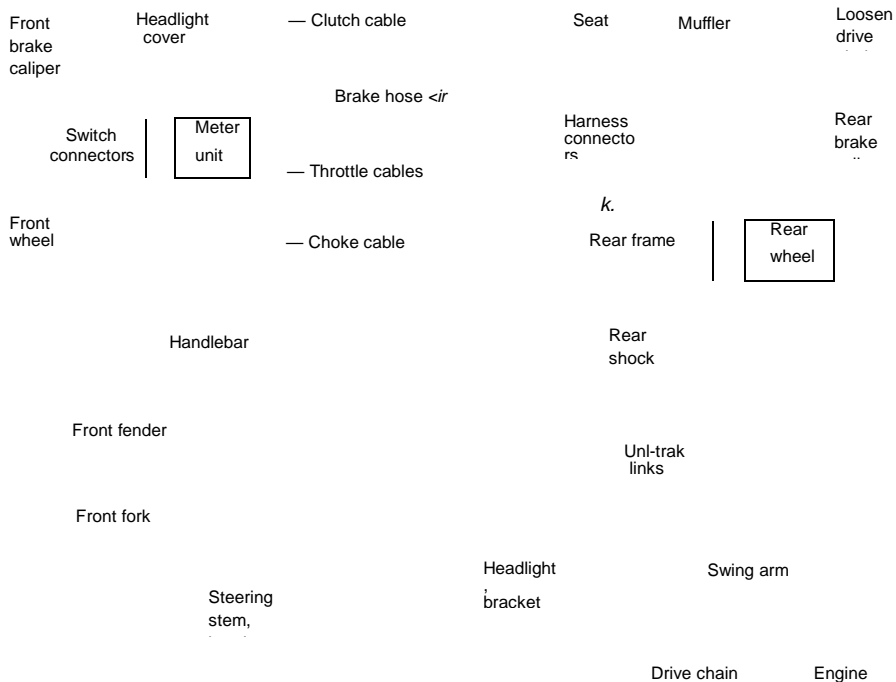

Electrical System

Table of Contents

Exploded View	14-2	Lighting System	14-15
Service Data	14-4	Headlight Horizontal Adjustment	
Special Tools		Headlight Vertical Adjustment	14-15
Precautions	14-5	Headlight Bulb Installation	
Battery	14-5	Headlight, Dimmer, or Passing	
Charging System	14-5	Switch Inspection	14-16
Measuring Regulator/Rectifier		Front Brake Light Switch Inspection. . .	
Output Voltage (Loaded)		Rear Brake Light Switch Adjustment . .	
Measuring Stator Coil Resistance	14-5	Rear Brake Light Switch Inspection ...	
Testing Stator Coil Insulation		Turn Signal Inspection	
Regulator/Rectifier Inspection	14-5	Tachometer and Water Temperature Gauge ..	14-16
Ignition System	14-7	Disassembly	14-16
Adjustment	14-7	Maintenance	14-17
Spark Plug Cleaning and Gapping	14-7	Meter Mounting Inspection	
Removal/Installation	14-7	Meter Power Supply Test	
Magneto Removal or Installation	14-7	Tachometer Inspection	14-17
Magneto Installation	14-7	Water Temperature Gauge	
Ignition Coil Installation	14-7	Circuit Check	
Ignition System Maintenance	14-8	Water Temperature Sender Check	
Switch Inspection	14-8	Radiator Fan	14-17
Diode Inspection		Initial Check	14-17
Ignition Coil Inspection	14-9	Fan Motor Inspection	14-17
CDI Unit Inspection	14-10	Fan Relay Inspection	14-17
Exciter or Pickup Coil Inspection	14-10	Fan Switch Inspection	
Electric Starter System	14-11	Wiring Diagram	14-19
Starter Motor Removal	14-11		
Installation Points	14-11		
Starter Motor Disassembly	14-11		
Starter Motor Assembly Points	14-11		
Starter Clutch Removal	14-12		
Installation Point	14-12		
Starter Motor Brush Length	14-12		
Brush Spring Inspection	14-12		
Commutator Cleaning and Inspection . .	14-12		
Armature Inspection	14-13		
Brush Plate Inspection	14-13		
Positive Brush Assembly Inspection . . .	14-13		
Starter Relay Inspection	14-13		
Starter Circuit Relay Inspection	14-14		
Starter Button Inspection	14-14		
Starter Clutch Inspection	14-14		

'Refer to Base Manual

14-2 ELECTRICAL SYSTEM

Exploded View

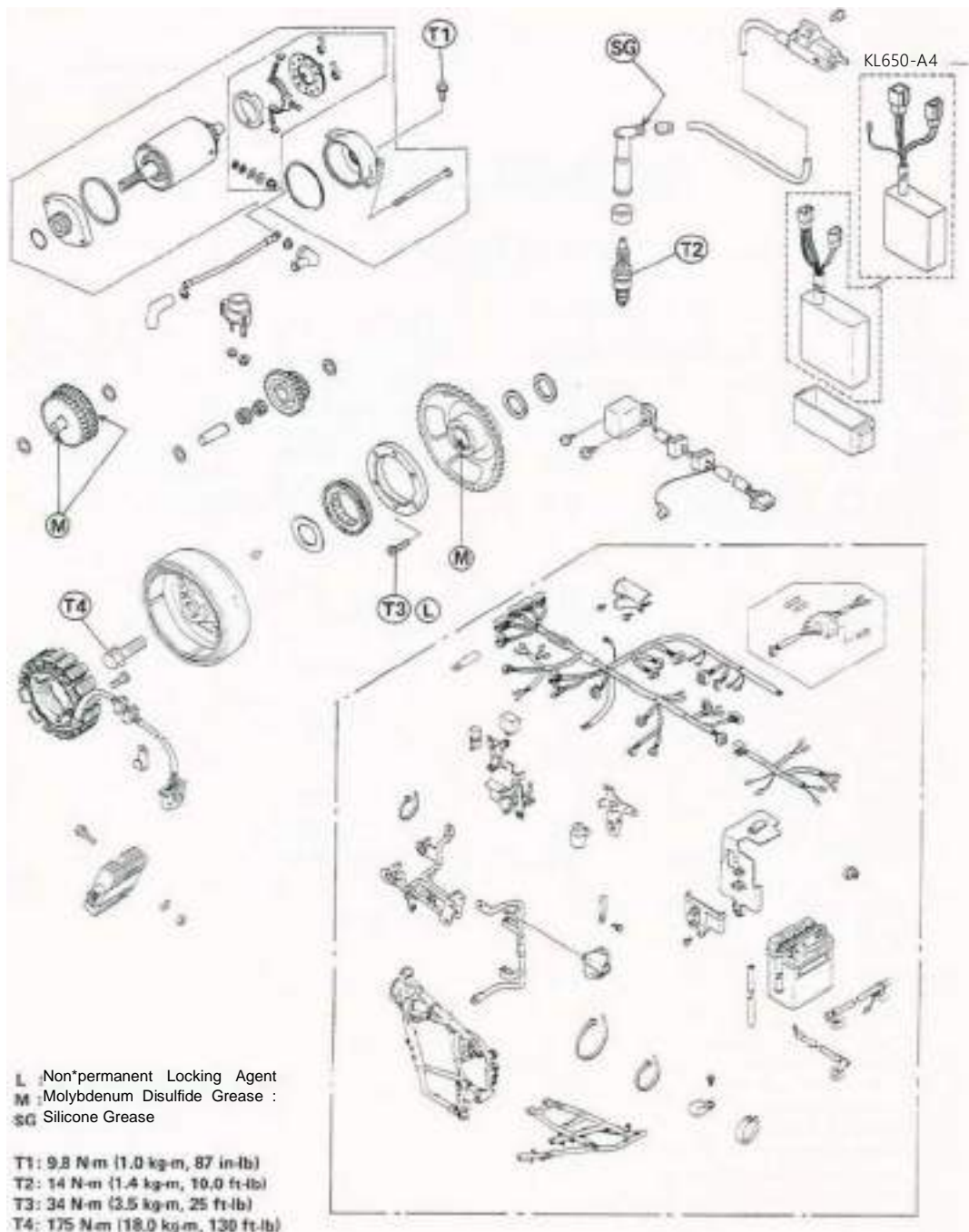

ELECTRICAL SYSTEM 14-3

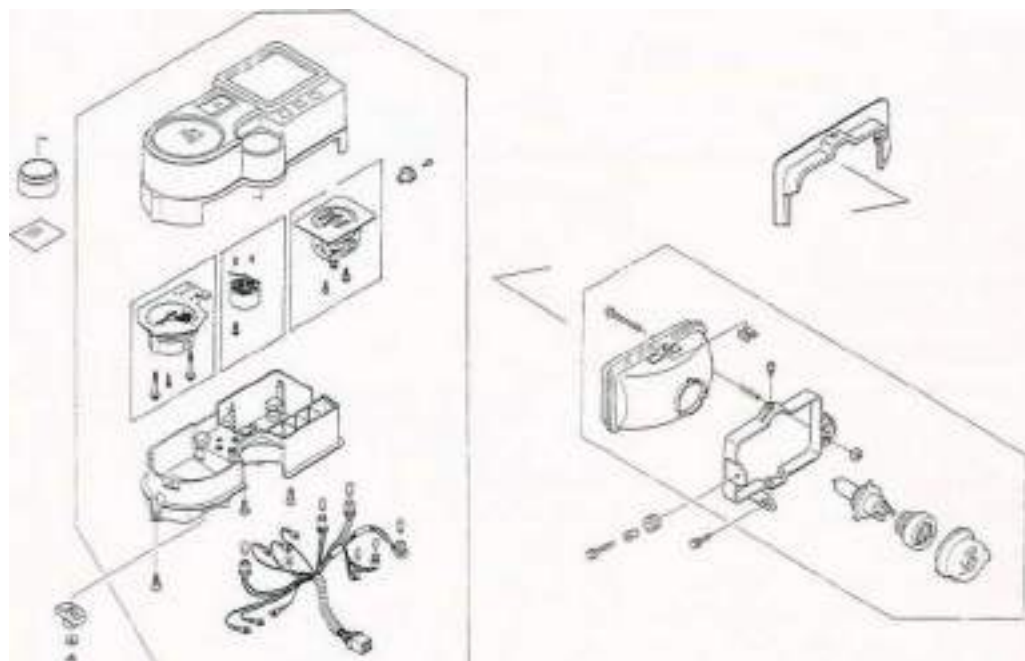

14-4 ELECTRICAL SYSTEM

Service Data

Item	Standard	Service Limit
Battery:		
Electrolyte level	Between upper and lower levels	-----
Specific gravity	1.280 @20°C (68° F)	-----
Charging System:		
Regulator/rectifier output voltage	Battery - 15 V	-----
Magneto stator coil resistance	0.3 - 1.0 n	-----
Ignition System:		
Sparkplug: Type	NGK DPR8EA-9 or ND X24EPR-U9 @<D>(Q> NGK DP8EA-9 or ND X24EP-U9	-----
Gap	0.8 — 0.9 mm	-----
Ignition coil:		
Arcing distance	7 mm or more (3-needle method)	-----
Primary winding resistance	0.15-0.21 n	-----
Secondary winding resistance	3.8 — 5.8 kii	-----
Exciter coil resistance	100- 200 n	-----
Pickup coil resistance	100- 150 12	-----
Electric Starter System:		
Starter motor: Carbon brush length	12.0- 12.5 mm	6 mm
Commutator diamater	28 mm	27 mm
Meter Unit:		
Water temperature sender resistance	47 — 57 Si @80°C(176°F) 26 -30fi @100°C (212°F)	-----
Radiator Fan:		
Radiator fan switch: ON	Above 94- 100°C (201 -212°F)	-----
OFF	Below 91°C (196°F)	-----

@ : Australian Model
©: Italian Model

© : South African Model
<0> : US Model

Precautions

Refer to the Base Manual, noting the following. oBecause of the large amount of current, never keep the starter button pushed when the starter motor will not turn over, or the current may burn out the starter motor windings.

Battery

Refer to the Base Manual, noting the following. •Refer to Cable, Wire, and Hose Routing in the chapter 1 for the battery vent hose routing.

Charging System

Charging System Wiring Diagram

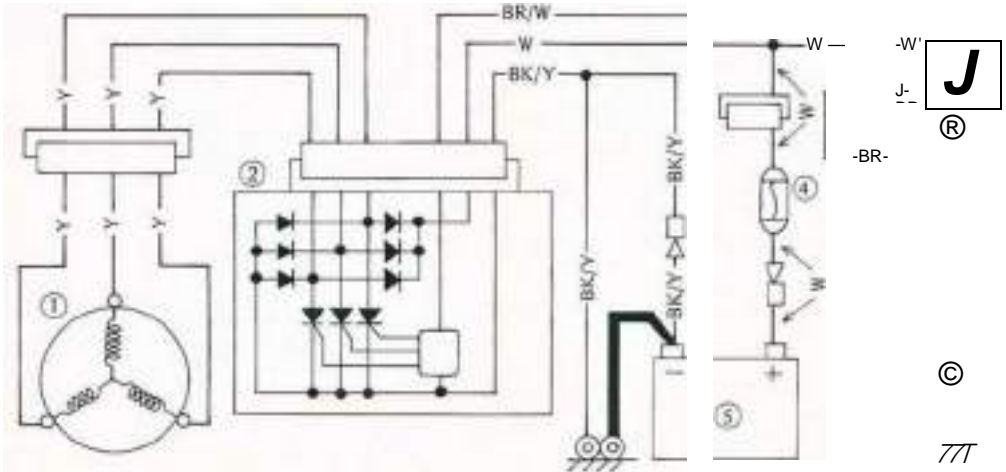

- 1. Charging Coils (Magneto)
- 2. Regulator/Rectifier
- 3. Ignition Switch
- 4. Fuse 20A
- 5. Battery
- 6. Loads

Regulator/Rectifier Inspection

Rectifier Circuit Test:
•Remove the regulator/rectifier.

Measuring Stator Coil Resistance

Refer to the Base Manual, noting the following.

Stator Coil Resistance

Meter Connections:

Lead location

Female magneto connector (disconnected)

x 1 ft

Meter range

One meter load

One yellow lead

Another meter lead

Other yellow lead

Meter Reading

0.3- 1.0 ft



A. Regulator/Rectifier

14-6 ELECTRICAL SYSTEM

•Zero the ohmmeter, and connect it to the regulator/ rectifier terminals.

•Check the resistance between the terminals following the table.

★The resistance should be low in one direction and more than ten times as much in the other direction. If any two leads are low or high in both directions, the rectifier is defective and must be replaced.

NOTE

oThe actual meter reading varies with the meter used and the individual rectifier, but, generally speaking the lower reading should be from zero to the first % of the scale.

Regulator/Rectifier Terminal

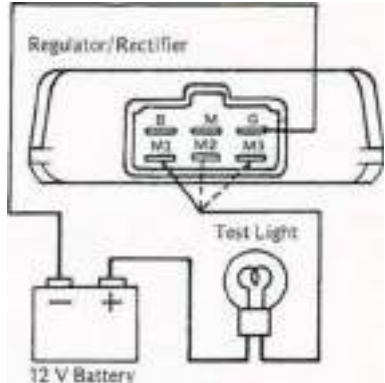
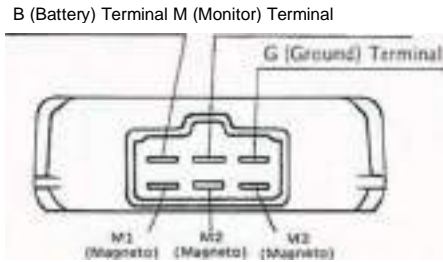

CAUTION

oThe test light limits the current flow through the regulator/ rectifier. Do not use an ammeter or multimeter in its place.

Rectifier Circuit Inspection

No.	Connections		Reading	Meter Range
	Meter (+) to	Meter (-) to		
1	M1	B	∞	x ion or x 100 I2
2	M2			
3	M3			
4	M1	G	0 - Vz scale	
5	M2			
6	M3			
7	B	M1	∞	
8		M2		
9		M3		
10	G	M1	∞	
11		M2		
12		M3		

Regulator Circuit Test:

- Remove the regulator/rectifier.
- Prepare the test tools shown.

Tools for Regulator Circuit Test

- Test light -• Bulb rated 12 V and 3 — 6 W
- Batteries -•■ 12 V battery and 6 V battery
- Test wires -•• 5 auxiliary wires

•Connect the test light and the 12 V battery to the regulator/rectifier as shown.

•Check M1, M2, and M3 terminals respectively.

Regulator Circuit Test-1st Step

Regulator Circuit Test-2nd Step

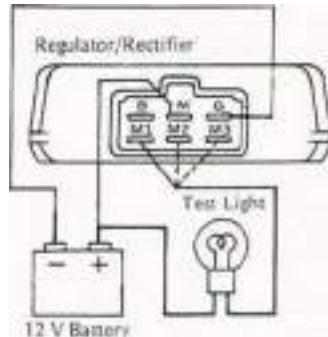

★If the test light turns on, the regulator/rectifier is defective. Replace it.

★If the test light does not turn on, continue the test.

•Momentarily apply 12 V to the voltage monitoring terminal.

•Check M1, M2, and M3 terminals respectively.

- *If the test light turns on, the regulator/rectifier is defective. Replace it.
- *If the test light does not turn on, continue the test.
- Momentarily apply 18 V to the voltage monitoring terminal by adding a 6 V battery.
- Check M1, M2, and M3 terminals respectively.

CAUTION

Do not apply more than 18 V to the regulator/rectifier and do not leave the 18 V applied for more than a few seconds, or the unit will be d

- Standard Spark Plug
- Plug Type: NGK DPf8EA-9 or ND X24EPR-U9
- @Q>@<0> NGK DP8EA-9 or ND X24EP-U9 Plug
- Gap: 0.8— 0.9mm
- Tightening Torque: 14N-m (1.4 kg-m, 10.0 ft-lb)

- @ : Australian Model
- 0 : Italian Model
- (S) : South African Model
- © : U.S. Model

Regulator Circuit Test-3rd Step

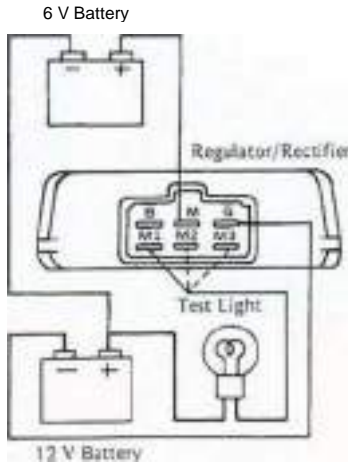

- *If the test light did not light when the 18 V was applied momentarily to the voltage monitoring terminal, the regulator/rectifier is defective. Replace it.
- *If the regulator/rectifier passes all of the tests described, it may still be defective. If the charging system still does not work properly after checking all of the components and the battery, test the regulator/rectifier by replacing it with a known good unit.

Ignition System

Adjustment:

Spark Plug Cleaning and Gapping

Refer to the Base Manual, noting the following.

Removal/Installation:

Magneto Removal or Installation

Refer to the Base Manual, noting the following.

- Replace the magneto flywheel bolt with a new one. This bolt is required to replace if it has been tightened once to the specified torque.
- Tightening procedure of the magneto flywheel bolt is the following.
 - oTighten the magneto flywheel bolt to 120 N-m (12.0 kg-m, 87 ft-lb) of torque. Do not overtighten it now.
 - oLoosen the bolt and then tighten it again to the same torque (above).
 - oFinally, tighten the bolt to the specified torque.

Tightening Torque

Magneto Flywheel Bolt:

175 N-m (18.0 kg-m, 130 ft-lb)

CAUTION

oUse a 6-point socket instead of a 12-point one to tighten the flywheel bolt to the specified torque.

Ignition Coil Installation

- Connect the primary leads to the ignition coil terminals as shown in the figure.

Ignition Coil Terminals

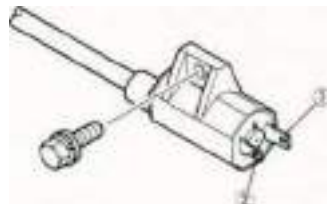

1. (+) Terminal <- BK 2. (-) Terminal <- BK/Y

14-8 ELECTRICAL SYSTEM

Ignition System Maintenance:
Ignition System Wiring Diagram

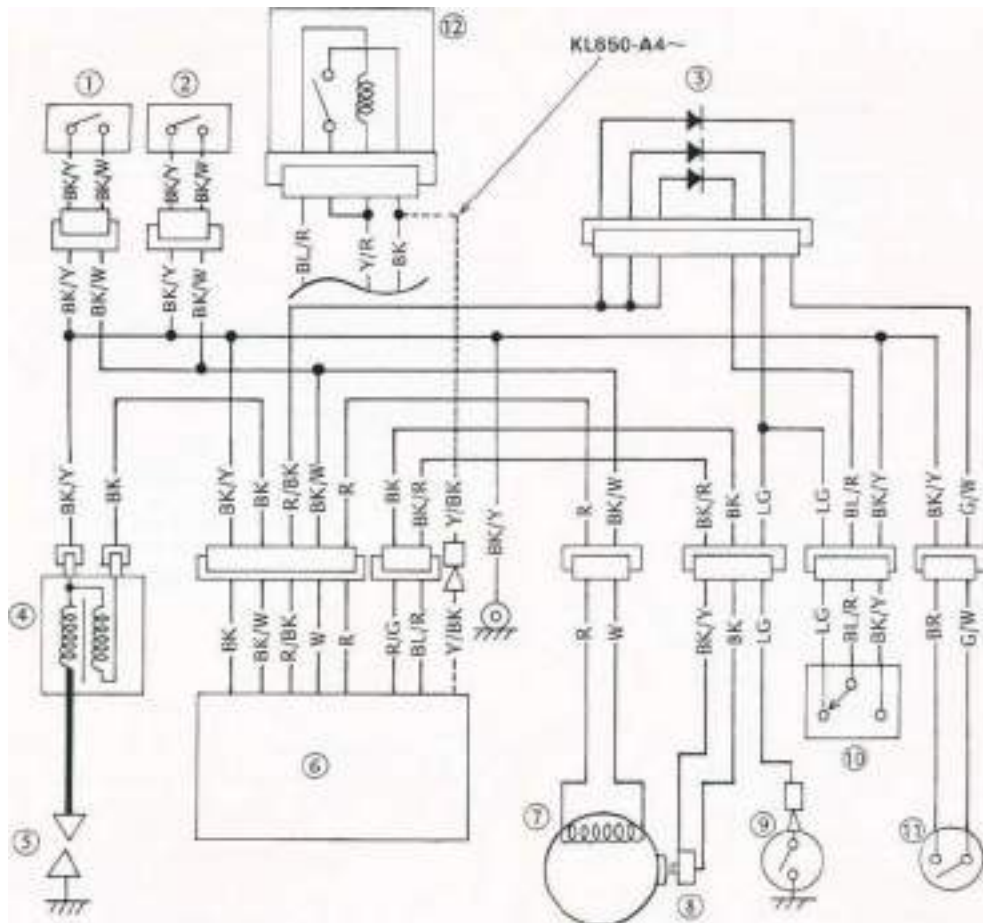

1. Ignition Switch
2. Engine Stop Switch
3. Diodes
4. Ignition Coil
5. Spark Plug
6. CDI Unit
7. Exciter Coil (Magneto)
8. Pickup Coil
9. Neutral Switch
10. Starter Lockout Switch
11. Side Stand Switch
12. Starter Circuit Relay

Switch Inspection

Refer to the Base Manual, noting the following.

Starter Lockout Switch Connections

Color	BK/Y	BL/R	LG
When the clutch lever is pulled on			
When the clutch lever is released			

Engine Stop Switch and Starter Button Connections

	Engine Stop Switch			Starter Button		
OFF RUN	BK/W	BK/Y	BR		Y/R	Pushed



A. Starter Lockout Switch C. Engine Stop Switch
B. Ignition Switch



A. Magneto 6-pin Connector
B. Neutral Switch and Pickup Coil 3-pin Connector
C. Diodes
D. CDI Unit



A. Engine Stop Switch 6-pin Connector (Red)
B. Ignition Switch 6-pin Connector (Black)
C. Starter Lockout Switch 3-pin Connector

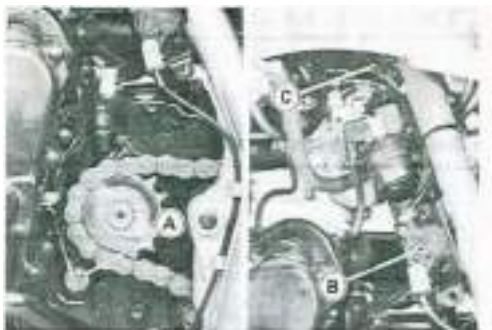

A. Neutral Switch
B. Side Stand Switch
C. Side Stand Switch 2-pin Connector

Ignition Coil Inspection

Refer to the Base Manual, noting the following.

Ignition Coil Test (Arcing Distance)



© **Bif:**
-ç (?+ <|)4 → d

1. Electro Tester: 57001-980
2. Ignition Coil

Ignition Coil Resistance

Primary: 0.15 — 0.21 Ω
Secondary: 3.8 — 5.8 kΩ

1. Measure primary winding resistance.
2. Measure secondary winding resistance.
3. Ignition Coil

14-10 ELECTRICAL SYSTEM

CDI Unit Inspection

Refer to the Base Manual, noting the following.

CDI Unit Internal Resistance (KL500, KL650-A1 .A2.A3)

Unit : kΩ

		Meter Positive (+) Lead Connection							
		Lead	W	R	R/G	BL/R	BK/W	BK	R/BK
Meter (-) Lead Connection	W			∞	∞	∞	∞	∞	∞
	R		10 - 40		4 - 20	10 - 45	∞	4 - 20	3 - 15
	R/G		2 - 10	2 - 10		4 - 20	∞	0	1 - 6
	BL/R		60 - 240	60 - 240	30 - 150		∞	30 - 150	40 - 160
	BK/W		∞	∞	∞	∞		∞	∞
	BK		2 - 10	2 - 10	0	4 - 16	∞		1 - 6
	R/BK		4 - 20	4 - 20	1 - 6	5 - 25	∞	1 - 6	

CDI Unit Internal Resistance (KL650-A4~)

Unit : kΩ

		Meter Positive (+) Lead Connection							
		Lead	W	R	R/C	BL/R	BKAV	BK	Y/BK
c u o r T	W			∞	∞	∞	∞	∞	∞
	R		10-55		5-25	5-35	∞	5-25	20-90
	R/C		2-10	2-10		1-6	∞	0	10-50
	B/R		4-20	4-20	1-6	∞	∞	1-6	10-55
	BKAV		∞	∞	∞	∞	∞	∞	∞
	BK		2-10	2-10	0	1-6	∞	∞	10-50
5	Y/BK		15-80	15-80	10-50	10-55	∞	10-50	∞

Exciter or Pickup Coil Inspection

Refer to the Base Manual, noting the following.

Resistance of Exciter and Pickup Coil

Meter : x10S2

Connections female connectors (disconnected) W - R

: 100 - 200 H (Exciter Coil)

BK/Y-BK : 100 - 150 fi (Pickup Coil)

Electrical Starter System

Starter Motor Removal •Remove the muffler and exhaust pipe.

- Disconnect lead from starter motor terminal.
- Unscrew starter motor mounting bolts and pull the starter motor out of its guide.



A. Mounting Bolts C. Ground Lead
B. Starter Motor Terminal

CAUTION

Do not tap the starter motor shaft or body. Tapping on the shaft or body could damage the motor.

Installation Points

- When installing the starter motor, clean the starter motor legs and crankcase where the starter motor is grounded.
- Apply a small amount of engine oil to the O-ring.



A. O-ring B. Clean here.



- Take the armature out of the yoke housing.
- Remove the brush plate assembly from the housing.



- Remove the nut and remove the terminal bolt, and then remove the positive brush assembly with the plastic holder.

Starter Motor Assembly Points •Push the brush plate into place with its tab fitting in the yoke housing notch.



A. Tab B. Notch

- Install the brush end cover so that the long vertical tab on the brush plate aligns with the key slot in the cover.



A. Long Tab

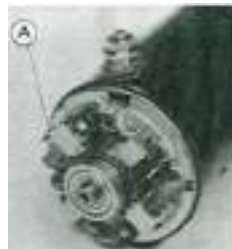

B. Key Slot

Starter Motor Disassembly

- Unscrew the retaining screws and pull off both end covers.

14-12 ELECTRICAL SYSTEM

•As a further check, these marks should align on the outside of the starter.

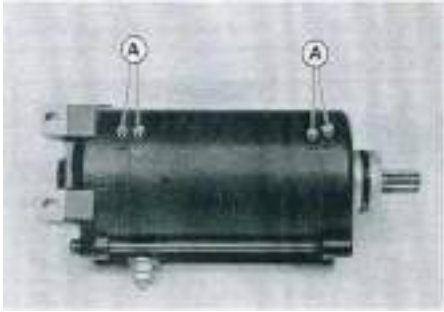

A. Align marks.

Starter clutch Removal

•Pull off the magneto flywheel from the crankshaft. •Holding the magneto flywheel in a vise, remove the Allen bolts.

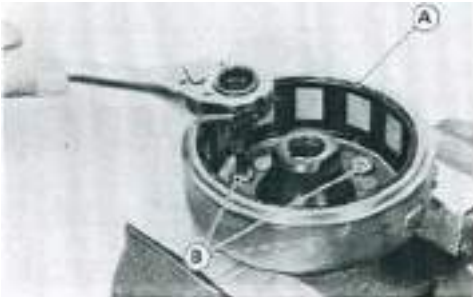

A. Magneto Flywheel B. Starter Clutch Allen Bolts •Separate the starter clutch assembly.



Installation Point

•Apply a non-permanent locking agent to the threads of the Allen bolts and tighten them to the specified torque.

Tightening Torque

Starter Clutch Bolts: 34 N-m (3.5 kg-m, 25 ft-lb)

Starter Motor Brush Length

•Measure the length of each brush.

•If any is worn down to the service limit, replace all brushes.

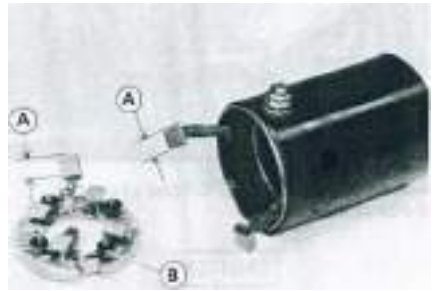

A. Measure brush length. B. Brush Spring

Brush Spring Inspection

•Check that the brush springs are in place and snap the brushes firmly into place.

★If not, reinstall or replace the spring.

Commutator Cleaning and Inspection •Smooth the commutator surface If necessary with fine emery cloth, and clean out the grooves.

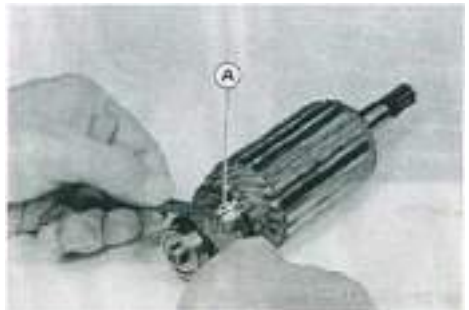

A. Commutator

- Measure the diameter of the commutator.
- ◆Replace the starter motor with a new one if the commutator diameter is less than the service limit.

Armature Inspection

- Using the x 1 Ω 2 ohmmeter range, measure the resistance between any two commutator segments. *If there is a high resistance or no reading ("∞") between any two segments, a winding is open and the starter motor must be replaced.

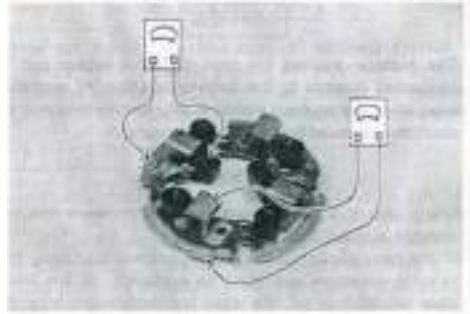

- Using the highest ohmmeter range, measure the resistance between the metal plate and the positive brush holders.

*If there is any reading at all, the brush holder has a short and the brush plate must be replaced.

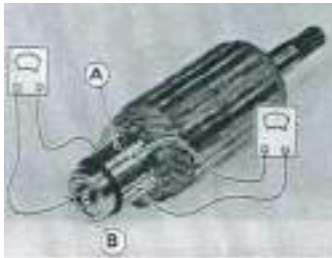

A. Segment

B. Shaft

- Using the x 1 Ω 1 ohmmeter range, measure the resistance between the positive brush and the terminal bolt.

◆If there is a high resistance or no reading ("∞"), a lead is open and the brush assembly must be replaced.

- Using the highest ohmmeter range, measure the resistance between the commutator and the shaft.

*If there is any reading at all, the armature has a short and the starter motor must be replaced.

Even if the foregoing checks show the armature to be good, it may be defective in some manner not readily detectable with an ohmmeter. If all other starter motor and starter motor circuit components check good, but the starter motor still does not turn over or only turns over weakly, replace the starter motor with a new one.



- Using the highest ohmmeter range, measure the resistance between the terminal bolt and the pole housing.

★If there is any reading at all, the insulation is faulty and the positive brush assembly must be replaced.

Brush Plate Inspection

- Using the x 1 Ω ohmmeter range, measure the resistance between the negative brushes and the plate.

*If there is not close to zero ohms, the brush plate must be replaced.

Starter Relay Inspection

- Disconnect the starter motor lead and battery positive (+) lead from the starter relay.

14-14 ELECTRICAL SYSTEM

CAUTION

OThe battery positive (+) lead with the rubber cap is connected directly to the battery positive (+) terminal even when the ignition switch is off, so take care not to short the removed lead to chassis ground.

•Using the x 1 i2 ohmmeter range, measure the resistance across the relay terminals.

*If the relay clicks but the meter does not read zero, the relay is defective and must be replaced. If the relay does not click at all, the relay is defective and must be replaced.

*If the relay makes a single clicking sound and the meter reads zero the relay is good. The trouble is in the starter motor or the motor power supply wires.

Switch Position:

Ignition switch ON Engine

stop switch RUN Starter

button ON

Neutral switch ON (Transmission is in Neutral)

Meter Connection:

Location Starter relay terminals
(leads disconnected)

Meter Range x 1 S2

Meter Reading: 0 £1 and relay clicks when starte
button is pushed.

Starter Button Inspection

•Using an ohmmeter, check to see that only the connections shown in the table have continuity (about zero ohms).

*If the switch has an open or short, repair it or replace it with a new one.

Starter Button Connections*

	BR	Y/R
Push		

*When engine stop switch is RUN.



A. RH Switch Housing 6-pin Connector (Red)



A. Starter Relay

B. Starter Circuit Relay

Starter Clutch Inspection

• Remove the alternator cover and starter idle gear, and turn the starter clutch gear by hand. The starter clutch gear should turn clockwise freely, but should not turn counterclockwise.

*If the clutch does not operate as it should or if it makes noise, disassemble the starter clutch, examine each part visually, and replace any worn or damaged parts.



A. Starter Clutch Gear C. Locked.
B. Turns freely.

Starter Circuit Relay Inspection

Starter circuit relay inspection is the same as the radiator fan relay inspection. Refer to the Fan Relay Inspection in the Base Manual.

Electric Starter System Wiring Diagram

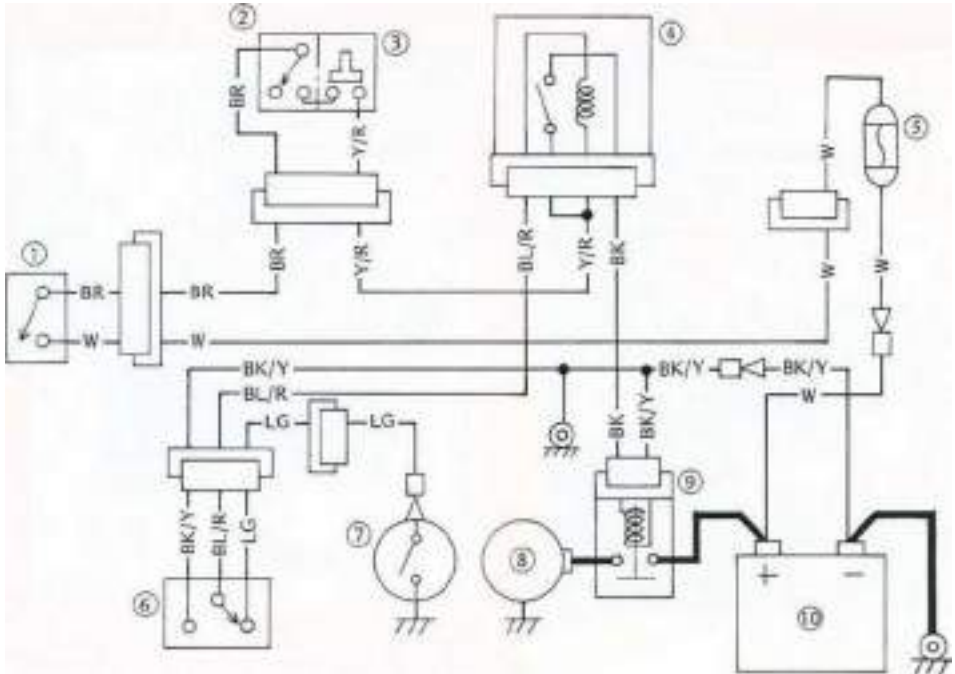

- | | | |
|--------------------------|---------------------------|------------------|
| 1. Ignition Switch | 5. Fuse 20A | 9. Starter Relay |
| 2. Engine Stop Switch | 6. Starter Lockout Switch | 10. Battery |
| 3. Starter Button | 7. Neutral Switch | |
| 4. Starter Circuit Relay | 8. Starter Motor | |

NOTE

oStarter clutch inspection can be done by removing the starter motor.

Lighting System

Headlight Vertical Adjustment

Refer to the Base Manual, noting the following.

- Loosen the headlight lower mounting bolt.



- | | |
|----------------------|------------|
| A. Starter Idle Gear | C. Locked. |
| B. Turns Freely. | |



- | |
|----------------------------------|
| A. Headlight Lower Mounting Bolt |
|----------------------------------|

14-16 ELECTRICAL SYSTEM

Headlight, Dimmer, or Passing Switch Inspection Refer to the Base Manual, noting the following.

Headlight, Dimmer, or Passing Switch Connections (Other than US and Canada)

Headlight Switch			Dimmer Switch			Passing Button		
Color	BR	R/W	Color	R/BK		R/Y	Color	BR R/BK*
ON			HI	O—				
OFF					--		Push	CmmmmD
PO			LO		O—	C		

*R/Y for Italian Model



A. Connector (Red)
 B. BU Switch Housing 6-pin Connector (Red)



LH Switch Housing 9-pin
 A. Screws

*Remove the tachometer or water temperature gauge.

Tachometer and Water Temperature Gauge

Disassembly:

•Remove the meter cover.

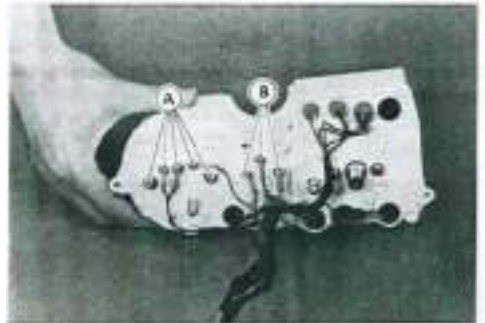

A. Tachometer Mounting Screws
 B. Water Temperature Gauge Mounting Screws

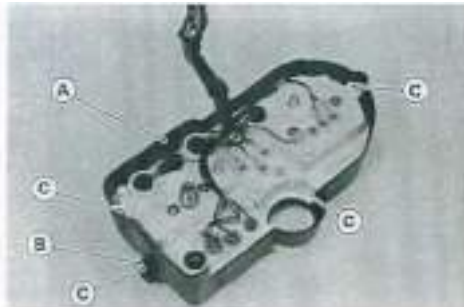

A. Meter Cover
 B. Knob
 C. Screw

Maintenance:

Refer to the Base Manual, noting the following.



A. Meter 9-pin Connector (White)

Fan Motor Inspection

Refer to the Base Manual, noting the following.



A. Radiator Fan Connector

Tachometer Inspection

The tachometer inspection is explained on the assumption that the ignition system operates normally.

- Turn the ignition switch ON.
- With the BK/Y and the BR lead connected, open or connect the BK lead to the BR lead repeatedly using an auxiliary wire. Then the tachometer hand should flick.
- ★If the hand does not flick, replace the tachometer unit.

NOTE

Fan Relay Inspection

Refer to the Base Manual, noting the following.



A. Fan Relay

Radiator Fan

Initial Check

Refer to the Base Manual, noting the following.

- The radiator and radiator fan assembly is mounted to left lower side of the frame head pipe.



A. Radiator Fan Switch

Wiring Diagram

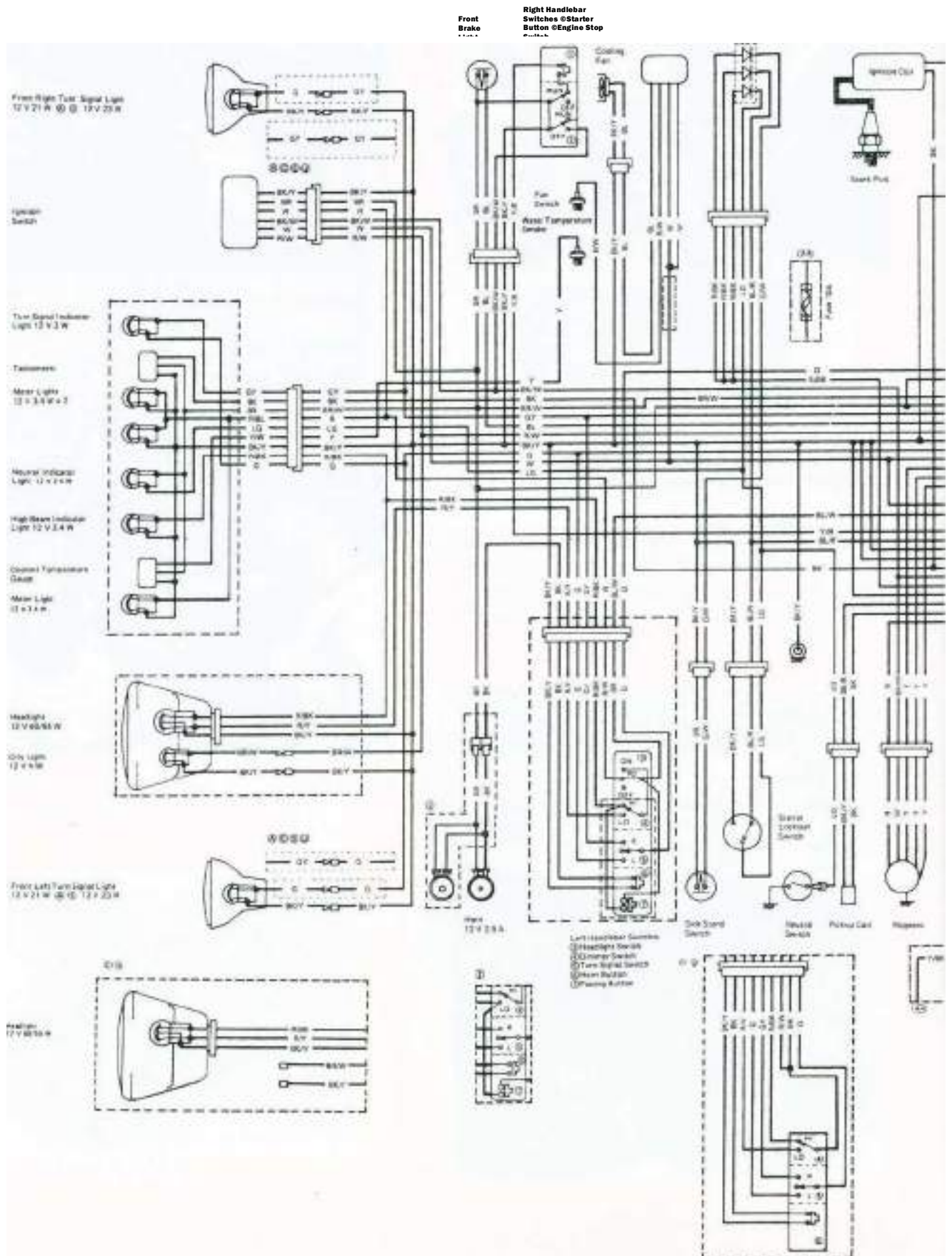

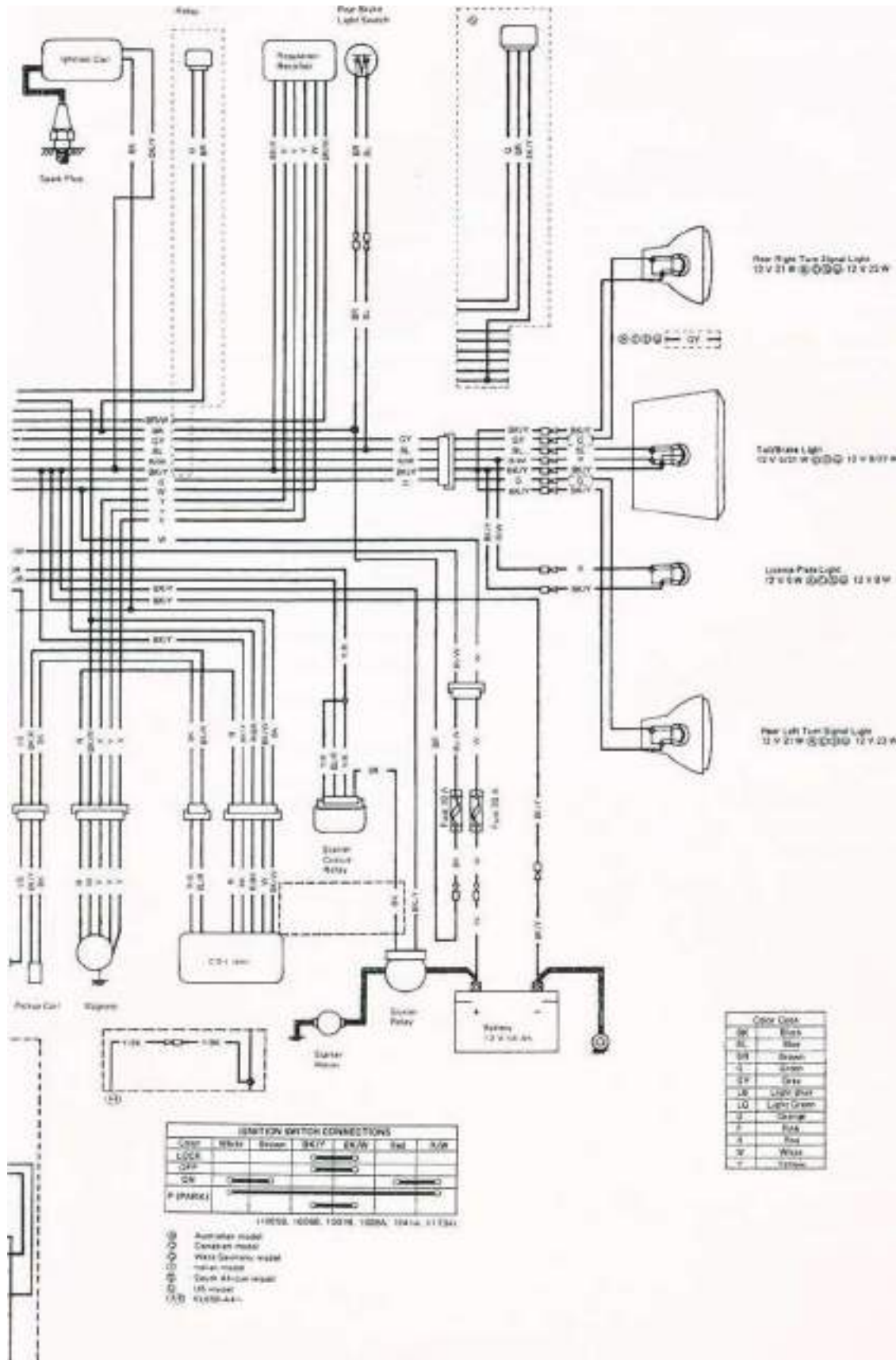

Appendix

Table of Contents

Additional Considerations for Racing
 Carburetor
 Spark Plug
 Spark Plug Inspection.....
Troubleshooting Guide 15-2
General Lubrication 15-2
 Lubrication 15-2
Nut, Bolt, and Fastener Tightness..... 15-2
 Tightness Inspection 15-2
Unit Conversion Table.....

'Refer to Base Manual

Troubleshooting Guide

Refer to the Base Manual, adding the following.

Engine Doesn't Start, Starting Difficulty:

- Starter motor not rotating:
 - Starter motor damaged
 - Battery voltage low
 - Relay not contacting or operating
 - Starter button not contacting
 - Wiring open or shorted
 - Ignition switch damaged
 - Engine stop switch damaged
 - Engine stop switch off
 - Fuse blown
- Starter lockout or neutral switch damaged
- Starter motor rotating but engine doesn't turn over:
 - Starter motor clutch damaged
 - Alternator rotor bolt loosened

Cable Lubrication



General Lubrication

Lubrication

- Before lubricating each part, clean off any rusty spots with rust remover and wipe off any grease, oil, dirt, or grime.
- Lubricate the points listed below with indicated lubricant.

NOTE

■ *Whenever the vehicle has been operated under wet or rainy conditions, or especially after using a high- pressure spray water, perform the general lubrication.*

Pivots: Lubricate with Motor Oil.
 Side Stand Clutch Lever
 Brake Lever Brake
 Pedal Rear Brake Rod
 Joint

Points: Lubricate with Grease.
 Throttle Inner Cable Lower Ends Clutch Inner
 Cable Upper End Side Stand Switch Inner
 Cable Lower End Speedometer Inner Cable*
 *Grease the lower part of the inner cable sparingly.

Cables: Lubricate with Rust Inhibitor.
 Choke Cable Throttle
 Cables Clutch Cable
 Side Stand Switch Cable

Nut, Bolt, and Fastener Tightness

Tightness Inspection

•Check the tightness of the bolts and nuts listed here. Also, check to see that each cotter pin is in place and in good condition.

NOTE

For the engine fasteners, check the tightness of them when the engine is cold at room temperature).

*If there are loose fasteners, retorque them to the specified torque following the specified tightening sequence. Refer to the appropriate chapter for torque specifications. If torque specifications are not in the appropriate chapter, see the basic torque table (see Torque and Locking Agent in the General Information chapter).

For each fastener, first loosen it by 1/2 turn, then tighten it.
 *If cotter pins are damaged, replace them with new ones.

Nut, Bolt, and Fastener to be checked

Wheels:

- Front Axle Nut Front Axle
- Nut Cotter Pin Rear Axle Nut
- Rear Axle Nut Cotter Pin

Brakes:

- Front Master Cylinder Clamp Bolts
- Front Caliper Mounting Bolts Rear
- Master Cylinder Mounting Bolts Rear
- Master Cylinder Bracket Bolts Rear
- Caliper Mounting Bolts Brake Lever
- Pivot Nut Brake Pedal Bolt Brake Rod
- Joint Cotter Pin

Suspension:

- Front Fork Clamp Bolts and Nuts Rear Shock
- Absorber Mounting Bolts and Nuts Swing Arm Pivot
- Shaft Nut Uni-trak Rocker Arm Pivot Nut Uni-trak
- Tie-rod Bolts and Nuts Steering:
- Stem Head Nut

Handlebar Clamp Bolts

Engine:

- Engine Mounting Bolts and Nuts Cylinder Head Bolts
- Cylinder Head Nuts Exhaust Pipe Holder Nuts
- Exhaust Pipe Mounting Bolt Muffler Mounting Bolts
- and Nuts Exhaust Pipe and Muffler Connecting
- Clamp Bolt Radiator Mounting Bolts Shift Pedal Bolt
- Others:

- Side Stand Nut Rear Frame
- Mounting Bolts Clutch Lever Holder
- Clamp Screws Clutch Lever Pivot
- Nut Footpeg Bracket Mounting Bolts
- Footpeg Pivot Cotter Pins Rear
- Carrier Mounting Bolts

Supplement - 2000 - 2001 Models

Table of Contents

Foreword	16-2
General Information	16-3
Model Identification.....	16-3
General Specifications	16-4
Torque and Locking Agenl	16-6
Fuel System	16-6
Specifications	16-6
Engine Top End	16-7
Exploded View	16-7
Engine Right Side / Left Side	16-8
Exploded View	16-8
Specifications	16-10
Engine Bottom End / Transmission	16-11
Exploded View	16-11
Final Drive	16-12
Exploded View	16-12
Specifications	16-12
Electrical System	16-13
Specifications	16-13
Wiring Diagram	16-14

16-2 SUPPLEMENT - 2000 - 2001 MODELS

Foreword

How to Use this Manual

This "Supplement - 2000 - 2001 Models" designed to be used in conjunction with the front part of this manual (up to 15-3) and /or Base Manual KLR600 Service Manual - Part No. 99924-1050-01. The specifications and maintenance procedures described in this chapter are only those that are unique to the KL650-A14/A15 model.

Complete and proper servicing of the KL650-A14/A15 model therefore requires mechanics to read both this chapter and the front of this manual.

General Information Model

Identification

KL650-A14 Left Side View



16-4 SUPPLEMENT - 2000 - 2001 MODELS

General Specifications

Items	KL650-A14	KL650-A15
Dimensions:		
Overall length	2 205 mm	
Overall width	940 mm	
Overall height	1 345 mm	
Wheelbase	1 495 mm	
Road clearance	240 mm	
Seat height	890 mm	
Dry weight	153 kg, (CA) 153.5 kg	
Curb weight: Front	81 kg, (CA) 81.5 kg	
Rear	97 kg	
Fuel tank capacity	23 L	
Performance:		
Minimum turning radius	2.4 m	
Engine:		
Type	4-stroke, DOHC, 4-valve, 1-cylinder	
Cooling system	Liquid-cooled	
Bore and stroke	100.0 x 83.0 mm	
Displacement	651 mL	
Compression ratio	9.5 : 1	
Maximum horsepower	35.3 kW (48PS) @6500 r/min (rpm)	
Maximum torque	55 N-m (5.6 kg-m, 40.5 ft-lb) @5500r/min (rpm)	
Carburetion system	Carburetor, Kelhin CVK40	
Starting system	Electric	
Ignition system	CDI	
Timing advance	Electronically advanced	
Ignition timing	From 10° BTDC @1 300 r/min (rpm) to 30° BTDC @3 300r/min (rpm)	
Spark plugs	NGK DPR8EA-9 or ND X 24 EPR-U9	
Valve timing:		
Inlet Open	19° BTDC	
Close	69° ABDC	
Duration	268°	
Exhaust Open	57° BBDC	
Close	31° ATDC	
Duration	268	
Lubrication system	Forced lubrication (wet sump)	
Engine oil: Grade	SE, SF or SG class	API SE, SF or SG API SH or SJ with JASO MA
Viscosity	SAE10W40, 10W50, 20W40, or 20W50	
Capacity	2.5 L	

SUPPLEMENT - 2000 - 2001 MODELS 16-5

Items	KL650-A14 KL650-A15
Drive Train:	
Primary reduction system:	
Type	Gear
Reduction ratio	2.272 (75/33)
Clutch type	Wet multi disc
Transmission:	
Type	5-speed, constant mesh, return shift
Gear ratios: 1 st	2.266 (34/15)
2nd	1.444 (26/18)
3rd	1.136 (25/22)
4th	0.954 (21/22)
5th	0.791 (19/24)
Final drive system:	
Type	Chain drive
Reduction ratio	2.866 (43/15)
Overall drive ratio	5.157 @Top gear
Frame:	
Type	Tubular, semi-double cradle
Caster (rake angle)	28°
Trail	112 mm
Front tire: Type	Tube type
Size	90/90-21 54S
Rear tire: Type	Tube type
Size	130/80-17 65S
Front suspension: Type	Telescopic fork (pneumatic)
Wheel travel	230 mm
Rear suspension: Type	Swingarm (uni-trak)
Wheel travel	230 mm
Brake Type: Front	Single disc
Rear	Single disc
Electrical Equipment:	
Battery	12 V 14 Ah
Headlight: Type	Semi-Sealed beam
Bulb	12 V 60/55 W (quartz-halogen)
Tail/brake light	12 V 8/27 W 12 V 5/21 W
Alternator: Type	Three-phase AC
Rated output	17 A @7 000 r/min (rpm), 14 V
Voltage regulator: Type	Short-Circuit

Specification subject to change without notice, and may not apply to every country. (CA):
California Model

16-6 SUPPLEMENT - 2000 - 2001

Torque and Locking Agent

Fastener	Torque			Remarks
	N-m	Kg-m	ft-lb	
Engine Right Side/Left Side Clutch spring bolts	8.8	0.9	78 in-lb	
Final Drive Engine sprocket Nut	98	10	72	

Fuel System specifications

Item	KL650-A14/A15
Carburetor:	
Idle speed	1300± 50r/min (rpm)
Standard specifications:	
Make.type	Keihin,CVK40
Main jet	#148
Main air jet	#50
Needle jet	#6
Jet needle	N 31R
Pilot jet	#40
Pilot air jet	#70
Pilot screw	1 3/8 turns out
Starter jet	#52
Service fuel level	0.5mm above -1.5mm below the float bowl mating surface.
Float height	17.5mm
High altitude adjustment (US model):	
Main jet	#145
Pilot jet	#38
Air Cleaner:	
Element oil: Grade	SE class
Viscosity	SAE30

Engine Top End

Exploded View

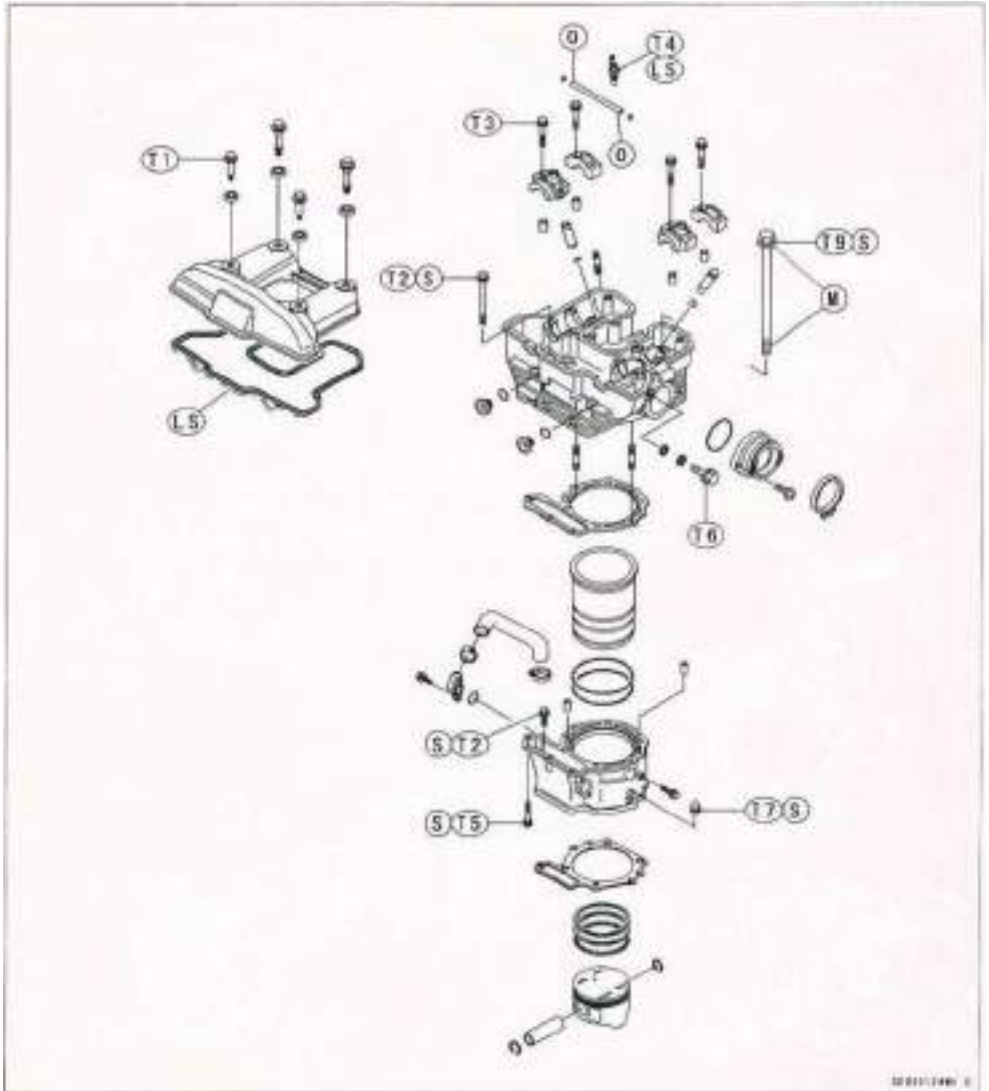

L: Non-permanent Locking Agent
 LS: Liquid Gasket (Silicone Sealant)
 M: Molybdenum Disulfide Grease 0:-
 Engine Oil
 S: Follow the specific tightening sequence.

T1: 7.8 N-m (0.80 kg-m, 69 in-lb)
 T2: 9.8 N-m (1.0 kg-m, 87 in-lb)
 T3: 12 N-m (1.2 kg-m, 104 in-lb)
 T4: 15 N-m (1.5 kg-m, 11.0 ft-lb)
 T5: 18 N-m (1.8 kg-m, 13.0 ft-lb)
 T6: 20 N-m (2.0 kg-m, 14.5 ft-lb)
 T7: 25 N-m (2.5 kg-m, 18.0 ft-lb)
 T8: 49 N-m (5.0 kg-m, 36 ft-lb)
 T9: 65 N-m (6.6 kg-m, 48 ft-lb)

16-8 SUPPLEMENT - 2000 - 2001 MODELS

Enginr Right Side / Left Side

Exploded View

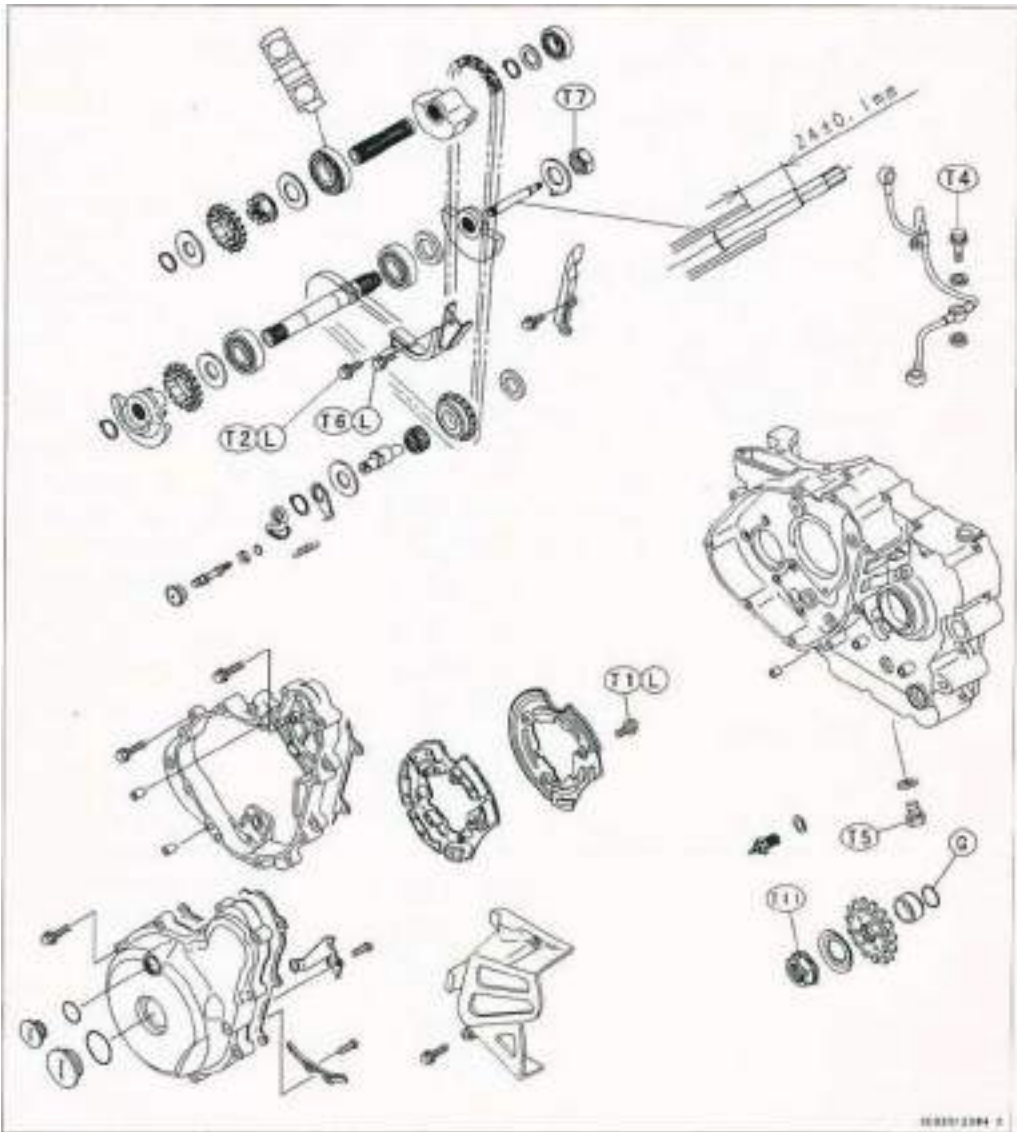

GrGrease

L:Non-permanent Locking Agent

M:Molybdenum Disulfide Grease

T1:9.8N-m(1.0kg-m,87in-lb)

T2:12N-m(1.2kg-m,104in-lb)

T3:15N-m(1.5kg-m,11.0ft-lb)

T4:20N-m(2.0kg-m,14.5ft-lb)

T5:23N-m(2.3kg-m, 16.5ft-lb)

T6:25N-m(2.5kg-m, 18.0ft-lb)

T7:44N-m(4.5kg-m,33ft-lb)

T8:120N-m(12.0kg-m,87ft-lb)

T9:130N-m(13.5kg-m, 98ft-lb)

T10:8.8N-m(0.9kg-m,78in-lb)

T11:98N-m(10kg-m,72ft-lb)

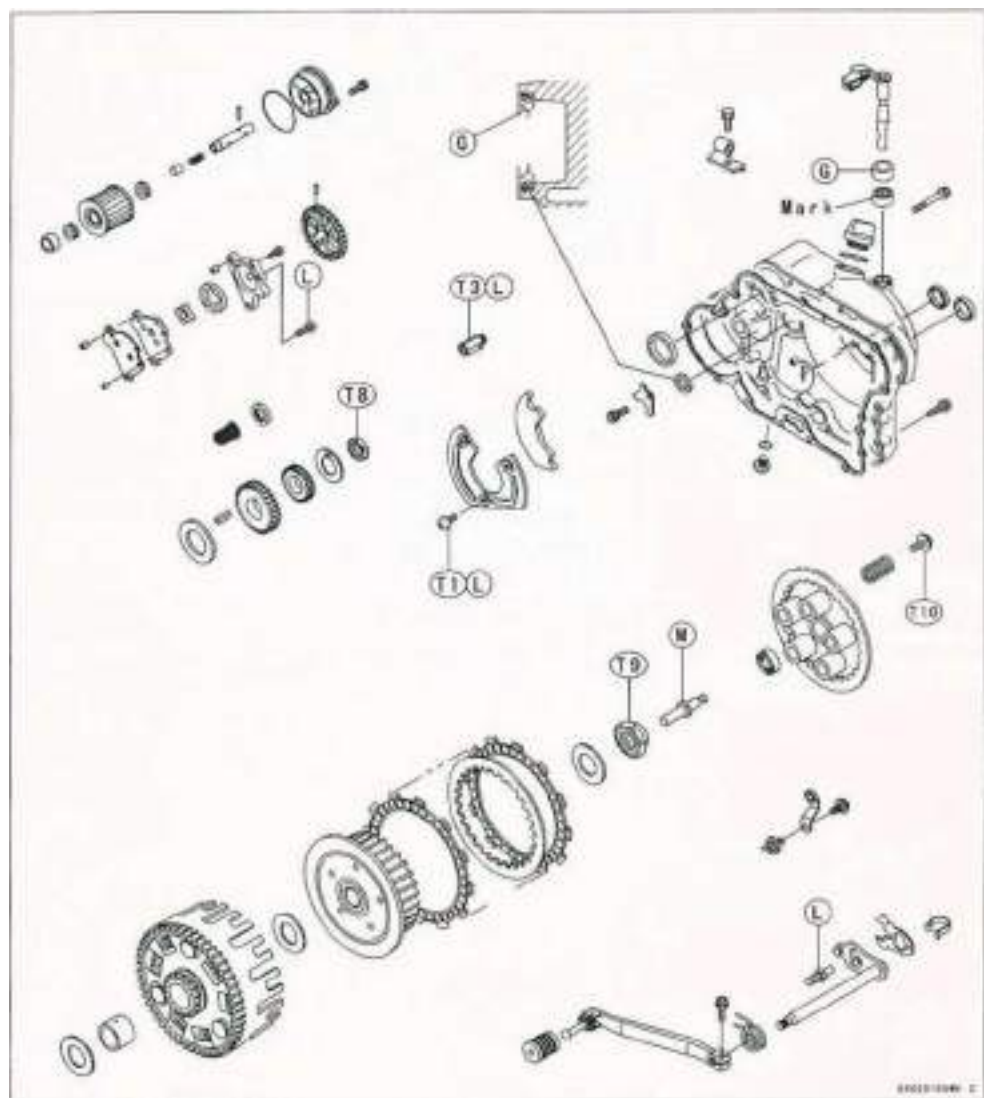

16-10 SUPPLEMENT - 2000 - 2001 MODELS

Specifications

Item	Standard	Service Limit
Clutch:		
Clutch lever play	2-3 mm 10-15 mm (at lever end)	-----
Friction plate thickness	2.8-3.1 mm	2.6 mm
Friction, steel plate warp	Less than 0.2 mm	0.3 mm
Clutch spring free length	38.7 mm	36.4 mm
Engine Lubrication System:		
Engine oil: Grade	SE, SF, or SG class (On and After KL650-A15) API SE, SF or SG API SH or SJ with JASO MA	
Viscosity	SAE 10W40, 10W50, 20W40, or 20W50	-----
Amount	2.2 L (filter is not removed) 2.5 L (filter is removed)	----- -----
Level	Between upper and lower level lines	-----
Relief valve opening pressure	430 - 590 kPa (4.4 - 6.0 kg/cm ² , 63 - 85 psi)	
Oil pressure	78- 147 kPa (0.8 - 1.5 kg/cm ² , 11 - 21 psi)	-----
@4000 rpm (r/min), 90°C (194°F)		

Engine Bottom End/Transmission

Exploded View

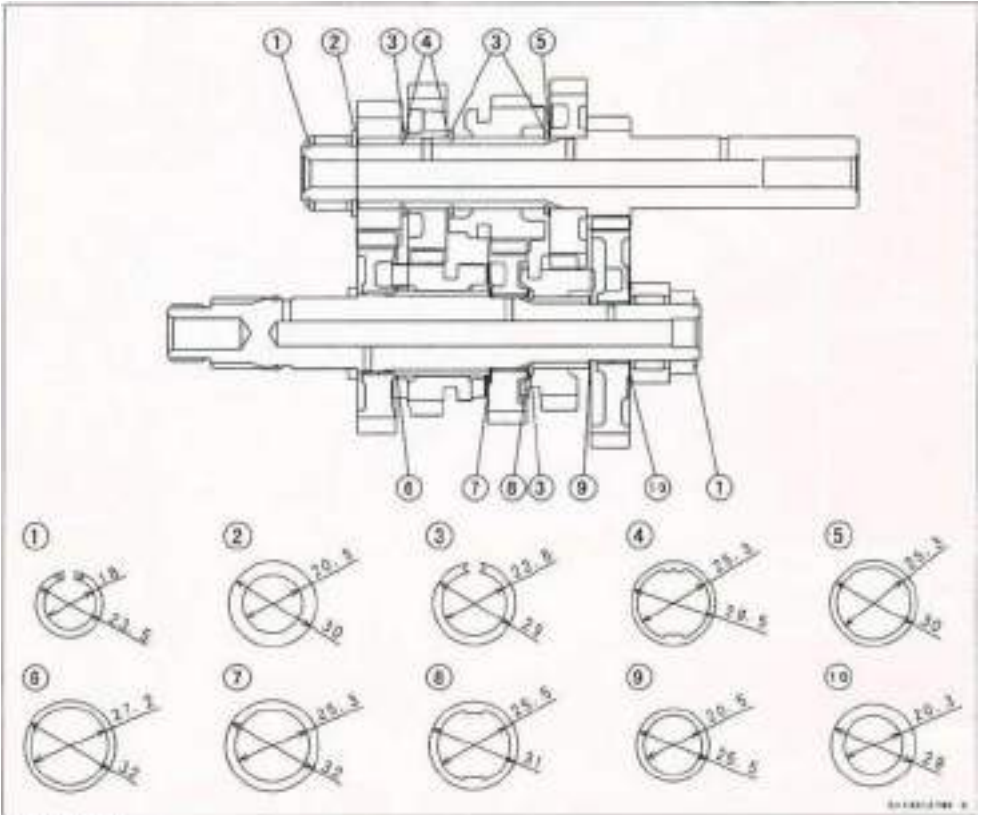
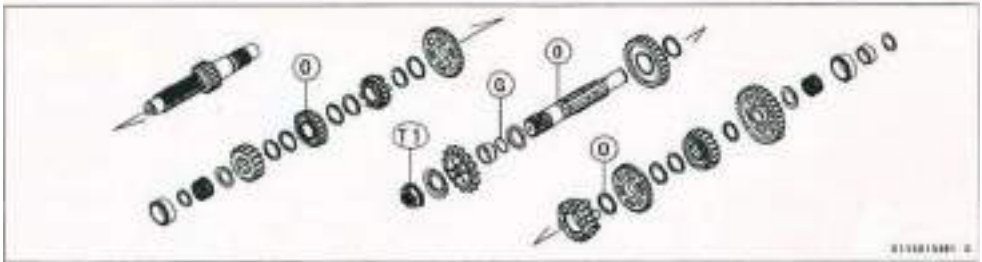

G: Grease

O: Engine Oil

T1: 9.8 N-m (10kg-m, 72 ft-lb)

16-12 SUPPLEMENT - 2000 - 2001 MODELS

Final Drive

Exploded View

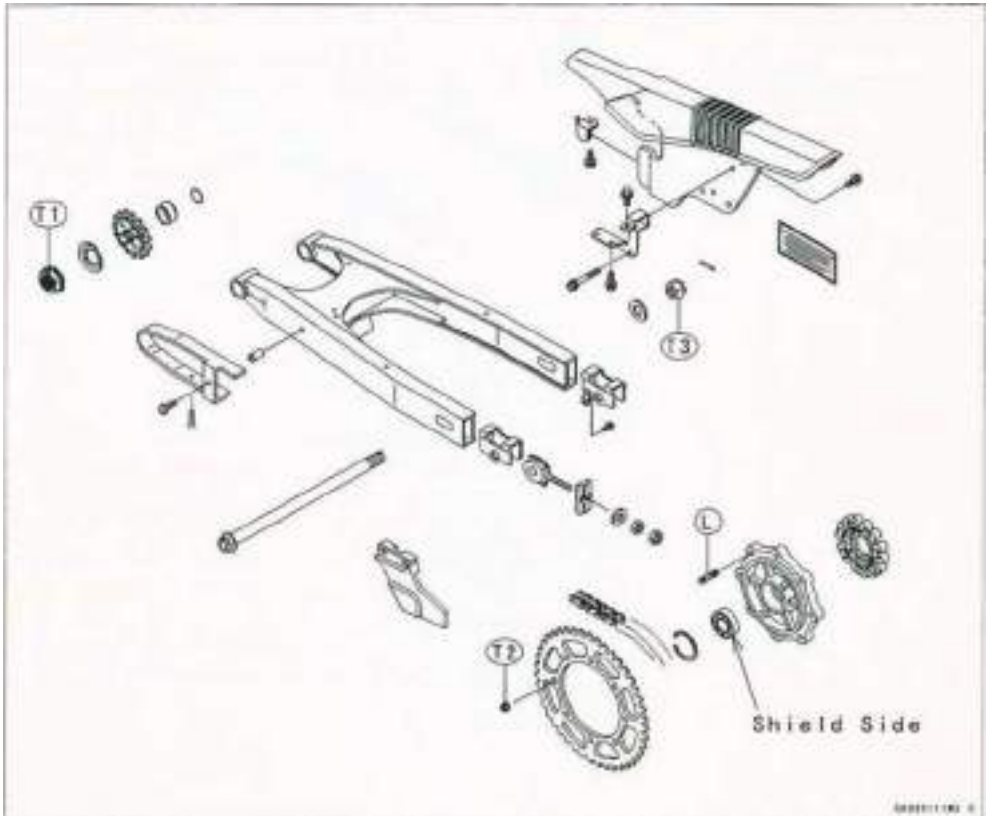

L : Non-permanent Locking Agent

T1 : 98 N-m (10kg-m,72ft-lb)

T2 : 32 N-m (3.3kg-m,24 ft-lb)

T3 : 93 N-m (9.5kg-m,69ft-lb)

Specifications

Item	Standard	Service Limit
<p>Drive Chain: Standard chain : On and After KL650-A14 Chain slack Chain 20-link length</p>	<p>EK520SR-0, 106L 50 - 55 mm 317.5 - 318.1mm</p>	<p>50 - 60 mm 323mm</p>

Electrical System

Specifications

Item	Standard	Service Limit
Battery:		
Electrolyte level	Between upper and lower levels	----
Specific gravity	1.280@20°C (68° F)	----
Charging System:		
Regulator / rectifier output voltage	Battery - 15 V	----
Magneto stator coil resistance	0.3 - i.on	----
Ignition System:		
Spark plug: Type	NGK DPR8EA-9 or ND X24EPR-U9	----
Gap	0.8 - 0.9 mm	----
Ignition coil:		
Arcing distance	7mm or more (3-needle method)	----
Primary winding resistance	0.15 -0.21 a	---
Secondary winding resistance	3.8-5.8k O	----
Exciter coil resistance	100 - 200il	----
Pickup coil resistance	100- 150Q	----
Electric Starter System:		
Starter motor: Carbon brush length	12.0 - 12.5 mm	6 mm
Commutatoy diameter	28 mm	27 mm
Meter Unit:		
Water temperature sender resistance	47 - 57 Q @80t3 (176° F)	----
	26-30H @ IOOt (212° F)	
Radiator fan switch: ON	Above 94 - 100°C 201-212° F)	----
OFF	Below 91 "C (196" F)	

16-14

KL650-A14/A15 Wiring Diagram

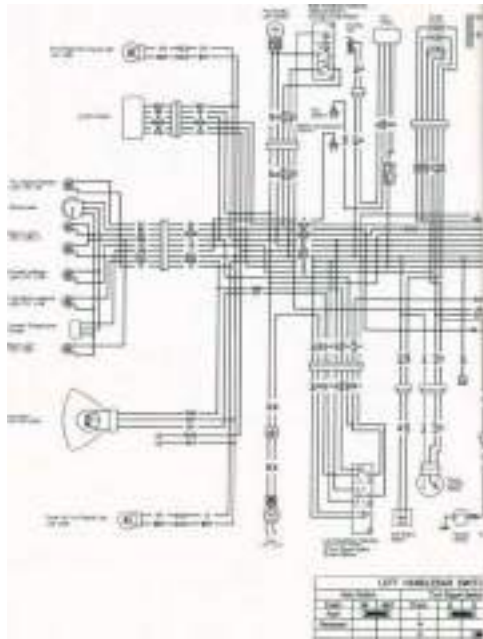

SUPPLEMENT - 2002 MODEL 17-1

Supplement - 2002 Model

Table of Contents

Foreword	17-2
How to Use this Manual.....	17-2
General Information.....	17-3
General Specifications.....	17-3
Torque and Locking Agent.....	17-4
Engine Right Side/Left Side.....	17-6
Specifications	17-6
Engine Oil and Oil Filter.....	17-6
Engine Oil Change.....	17-6

17-2 SUPPLEMENT - 2002 MODEL

Foreword

How to Use this Manual

This "Supplement - 2002 Model" designed to be used in conjunction with the front part of this manual (up to 16-15) and/or Base Manual KLR600 Service Manual - Part No. 99924-1050-01. The specifications and maintenance procedures described in this chapter are only those that are unique to the KL650-A16 model.

Complete and proper servicing of the KL650-A16 model therefore requires mechanics to read both this chapter and the front of this manual.

SUPPLEMENT - 2002 MODEL 17-3

General Information

General Specifications

Items	KL650-A16
Dimensions:	
Overall length	2205 mm
Overall width	940 mm
Overall height	1 345mm
Wheelbase	1 495 mm
Road clearance	240 mm
Seat height	890 mm
Dry weight	153 kg, (CA) 153.5 kg
Curb weight:	
Front	81 kg, (CA) 81.5 kg
Rear	97 kg
Fuel tank capacity	23 L
Performance	
Minimum turning radius	2.4 m
Engine	
Type	4-stroke, DOHC, 4-valve, 1-cylinder
Cooling system	Liquid-cooled
Bore and stroke	100.0 x 83.0 mm
Displacement	651 mL
Compression ratio	9.5 : 1
Maximum horsepower	35.3 kW (48 ps) @6500 r/min (rpm)
Maximum torque	55 N-m (5.6 kgf-m. 40.5 ft-lb) @5500 r/min (rpm)
Carburetion system	Carburetor, Keihin CVK40
Starting system	Electric
Ignition system	CDI
Timing advance	Electronically advanced
Ignition timing	from 10 BTDC @1300 r/min (rpm) to 30 BTDC @3300 r/min (rpm)
Spark plugs	NGK DPR8EA-9 or ND X 24 EPR-U9
Valve timing:	
Inlet	
Open	19 BTDC
Close	69 ABDC
Duration	268
Exhaust	
Open	57° BBDC
Close	31 ATDC
Duration	268
Lubrication system	Forced lubrication (wet sump)
Engine oil:	
Type	API SE, SF or SG API SH or SJ with JASO MA
Viscosity	SAE10W40
Capacity	2.5 L

17-4 SUPPLEMENT - 2002 MODEL

General Information

Items	KL650-A16
Drive Train: Primary reduction system: Type Reduction ratio Clutch type Transmission: Type Gear ratios: 1st 2nd 3rd 4th 5th Final drive system: Type Reduction ratio Overall drive ratio	Gear 2.272 (75/33) Wet multi disc 5-speed, constant mesh, return shift 2.266 (34/15) 1.444 (26/18) 1.136(25/22) 0.954 (21/22) 0.791 (19/24) Chain drive 2.866 (43/15) 5.157 ©Top gear
Frame: Type Caster (rake angle) Trail Front tire: Type Size Rear tire: Type Size Front suspension Type Wheel travel Rear suspension: Type Wheel travel Brake type: Front Rear Electrical Equipment: Battery Headlight: Type Bulb Tail/brake light Alternator: Type Rated output Voltage regulator Type	Tubular, semi-double cradle 28 112 mm Tube type 90/90-21 54S Tube type 130/80-17 65S Telescopic lork (pneumatic) 230 mm Swingarm (uni-trak) 230 mm Single disc Single disc 12 V 14 Ah Semi-Sealed beam 12 V 60/55 W (quartz-halogen) 12V 5/21 W Three-phase AC 17 A @7000 r/min (rpm), 14 V Short-Circuit

Specification subject to change without notice, and may not apply to every country.
 (CA): California Model

SUPPLEMENT - 2002 MODEL 17-5

General Information

Torque and Locking Agent

Fastener	Torque			Remarks
	N-m	kgf-m	ft lb	
Fuel System:				
Fuel tap bolts	2.5	0.25	22 in-lb	
Engine Removal/Installation				
Engine mounting bolts and nuts				
10 mm	44	4.5	33	
8 mm	27	2.8	20	
Wheels/Tires:				
Front axle nut	88	9.0	65	
Rear axle nut	98	10	72	
Spoke nipples	5.1	0.52	45 in-lb	
Brakes:				
Brake pedal mounting bolt	8.8	0.9	78 in-lb	
Master cylinder mounting bolts	25	2.5	18	
Suspension/Steering:				
Steering stem nut	4.9	0.5	43 in-lb	
Swing arm pivot nut	88	9.0	65	
Front fork clamp bolts - upper	20	2.0	14	
Controls/Instruments:				
Handlebar clamp bolts	25	2.5	18	
Frame:				
Rear frame mounting bolts	27	2.8	20	
Step holder mounting bolts	32	3.3	24	
Electrical System:				
Fan switch	7.8	0.8	69 in-lb	

17-6 SUPPLEMENT - 2002 MODEL

Engine Right Side/Left Side

Specifications

Item	Standard	Service Limit
Engine Lubrication System:		
Engine oil: Type	API SE, SF or SG	-----
	API SH or SJ with JASO MA	
Viscosity	SAE10W40	-----
Capacity	2.2 L (filter is not removed)	-----
	2.5 L (filter is removed)	-----
Level	Between upper and lower level lines	-----
Relief valve opening pressure	430 - 590 kPa	-----
	(4.4 - 6.0 kgf/cm ² , 63 - 85 psi)	
Oil pressure	78- 147 kPa	-----
@4000 rpm (r/min), 90 C (194F)	(0.8 - 1.5 kgf/cm ² , 11 - 2.1 psi)	

Engine Oil and Oil Filter

Engine Oil Change

Type: API SE, SF or SG

API SH or SJ with JASO MA

Viscosity: SAE10W-40

Capacity: 2.2 L (Oil filler is not removed)

2.5 L (Oil filter is removed)

NOTE

Depending on the atmospheric temperature of your riding area, the engine oil viscosity should be changed accordingly to the chart.

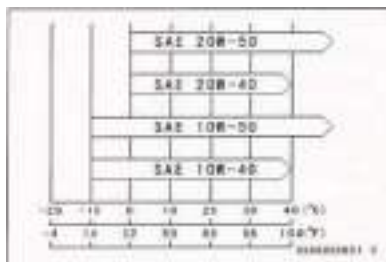

MOD

Year	Model #	Beginning Frame No.
1987	KL650-A1	JKAKLE A1 □ HA000001 or KL650A-000001
	KL500-A1	KL500A-000001
1988	KL650-A2	JKAKLEA1 □ JA008701 or KL650A-008701
	KL500-A2	KL500A-000501
1989	KL650-A3	JKAKLEA1 □ KA013601 or KL650A-013601
1990	KL650-A4	JKARLEA1DLA016001
1991	KL650-A5	JKARLEA1DMA018001
1992	KL650-A6	JKAKLEA1DNA021901
1993	KL650-A7	JKAKLEA1 □ PAC28001
1994	KL650-A8	JKARLEA1DRA030001
1995	KL650-A9	JKARLEA1 □ SA032001
2000	KL650-A14	JKARLEA1DYA057001
2001	KL650-A15	JKARLEA1 □ TA070001
2002	KL650-A16	JKARLEA1DZ0075001

□: This digit in the frame number changes from one machine to another.

-C Kawasaki
 KAWASAKI HEAVY INDUSTRIES, LTD.
 Consumer Products & Machinery Company
 Part No. 99924-1080-58