



<https://www.motomanuals.net/>

Workshop Manual

LAVERDA 650

MANUFACTURER'S NOTES

This manual has been written by Moto Laverda for authorized LAVERDA dealers and their skilled mechanics. The basic technical knowledge is therefore taken for granted. In all cases safety is the fundamental element on which the entire content is based.

The manufacturer reserves the right to make improvements at any time, should the need arise, and to make any particular changes for the sake of convenience or for any other reason of either a technical or a commercial nature.

Updated information will be supplied periodically describing any such changes made.

The most important information in the manual are highlighted as follows:

NOTE - Marks key information for greater clarity.

ATTENTION - Marks any information necessary to avoid damage to the motorcycle.

WARNING - Highlights information requiring especial care, since a mistaken procedure could make the motorcycle unsafe.

When working on the motorcycle, always take the following precautions:

1. Use new gaskets, circlips, seal rings, oil seals and split pins.
2. Use special tools where indicated.
3. Use original Laverda spare parts and the recommended lubricants.
4. After assembly, check that everything is sealed and working correctly.
5. Do not use petrol to clean painted parts or parts made of synthetic material.
6. Always tighten nuts and screws at the recommended torque value.
7. Pay special attention to technical circulars giving any variations and updates of the methods of intervention.



The manual provides a complete description of the **LAVERDA 650**.

The 650 Sport is the new two-cylinder four-stroke sports motorcycle with electronic ignition. Making use of the experience in the production of the eight-valve two-cylinder model, the 650 Sport is the maximum technical evolution of the engine and of Laverda itself. It is outstanding not only for its extremely sporty and aggressive styling, but also for its frame made completely of aluminium, its electronic injection, Racing suspensions and top quality components. It is a machine to "look after with loving care and attention". All this attention will be amply repaid by really pleasant use.

Location of the serial numbers

The serial numbers are located as follows:

Chassis (A): punched on the left side of the rear fork support plate indicating: international VIN code, CUNA numbering and an adhesive plate with the DGM approval number.

Engine (B): punched on the left side of the upper base indicating: model - engine number.

Approval number: an aluminium plate riveted onto the chassis beam on the left side.

Always quote these data when asking for information.

Guarantee

International I.M.O.L.A. Moto Laverda offers a specific guarantee on all new motorcycles through authorized Agents and Dealers. All complaints must be made through the Agent. No complaints will be considered if the correct procedure has not been followed.

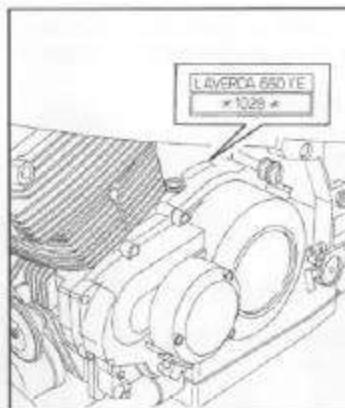

SUMMARY

	PRE-DELIVERY	5
A	= GENERALITY	9
B	= SERVICING	19
C	= ADJUSTING AND REGULATING	25
D	= ELECTRONIC INJECTION-IGNITION SYSTEM	41
E	= DISMANTLING THE BODYWORK	53
F	= DISMANTLING AND OVERHAULING THE ENGINE	58
G	= ELECTRIC SYSTEM - Diagram	89
H	= INJECTION - IGNITION - Diagram	96
I	= OVERHAULING THE CYCLE PARTS	99
L	= SPECIFIC EQUIPMENT	109
M	= BRAKING SYSTEM	111
N	= TIGHTENING TORQUES	116
O	= SPECIAL INSTRUCTIONS	118

INTERNATIONAL I.M.O.L.A. MOTO LAVERDA S.p.a.

Motorcycle Technical Service Department

INTERNATIONAL I.M.O.L.A. MOTO LAVERDA S.p.a.

Via Monte Pasubio, 119 - ZANE' - Vicenza - Italy

1st Edition Marzo 96

OPERATIONS TO BE PERFORMED BEFORE DELIVERY OF THE MOTORCYCLE

ATTENTION: Before taking the motorcycle out on the road, certain assembly operations and checks must be performed. Remember that all motorcycles have been tested, however we believe it is good safety practice for the dealers to make a further check of the most important components.

Proceed as follows:

- Remove the motorcycle from the packing case.
- Fit the front wheel and brake calipers. Ensure that the front wheel spindle and front caliper bolts are tightened to the correct torque. Fit the front mudguard.
- Pull the front and rear brake levers until resistance is felt through the levers and the brakes are up to pressure.
- Check the levels of brake fluid in the rear (B) and front brake reservoirs and also the clutch fluid reservoir.
- Check drive chain tension is correct (D).
- Check engine oil level.
- Check for correct tightening torque on both wheel spindles, brake caliper bolts and all major nuts and bolts. Tightening torque are listed at the rear of this manual

ATTENTION: Use unleaded fuel.

Remember that this type of petrol has properties that corrode parts made of ordinary rubber: the motorcycle is provided with special materials that resist unleaded fuel. If they have to be replaced, we recommend using only original spare parts so as to avoid encountering severe problems.

Summing up, the operations and checks to be performed are the following:

1. Fit the front wheel and the brake calipers.
2. Fit the front mudguard.
3. Check the brakes.
4. Check the hydraulic fluid in the brakes and clutch.
5. Check the engine oil.
6. Check the tyre pressure.
7. Tighten the wheel pins and the nuts and bolts.
8. Charge the battery.
9. Fill up with **unleaded fuel**.

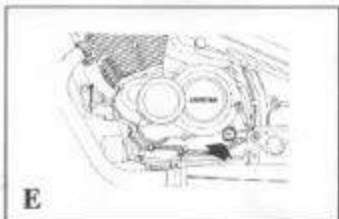
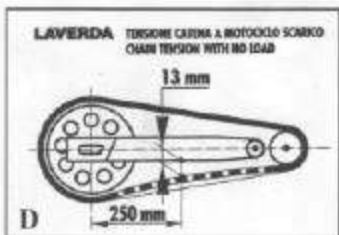
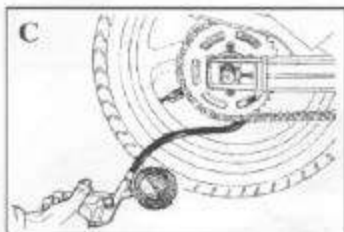
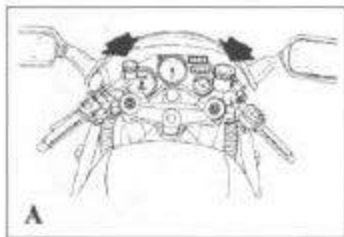

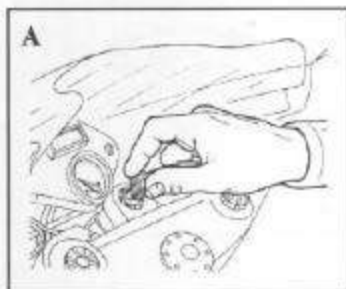

At this point it is necessary to check correct lighting of the lamps and services (headlamp, tail lamp, flashing indicators, brake lights, dashboard pilot lights) by means of the electric controls on the handlebar (C).

Check the alignment of the headlamp (E) and adjust it if necessary.

Now you can start the engine, proceeding as follows:

1. Turn the ignition key in a clockwise direction: (A)
2. At this point you will hear the hum of the injection pump which is loading the system. After a few seconds the pump switches off, indicating that the injection system is under pressure; you can now start the engine, pressing the button provided (B). Do not start the engine before the pump has finished loading the system.

ATTENTION: The starting motor might be turning but the engine may not start; in this case the side stand could be in open position. Close the stand and the engine will start correctly.

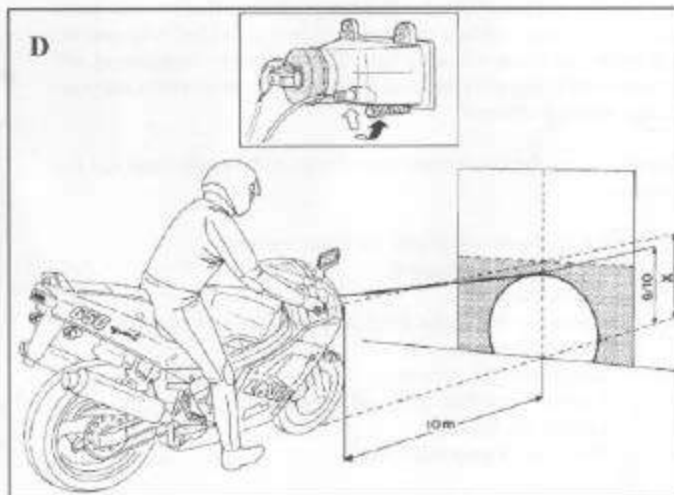
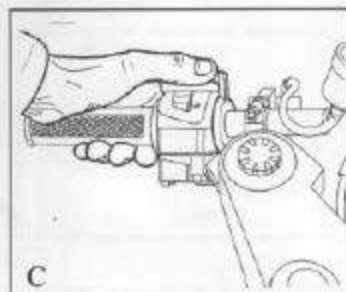
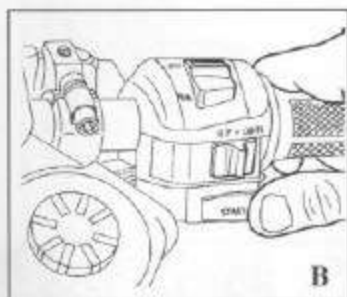

Now you can try out the motorcycle on the road, being particularly careful for the first kilometres. This will enable you to get familiar with the vehicle and its controls.

NOTE. Use this manual as a guide to specific jobs. This manual has been prepared with the aim of providing important technical support for all personnel involved in the maintenance and repair of the LAVERDA 650. Remember that it is indispensable to have direct knowledge of the technical data provided, which is of decisive importance for the professional training of mechanical or electronic operators. **Always remember to assess the Customer's indications carefully.**

Make a clear note of any malfunctions and organize your work rationally so as to avoid wasted time. Make sure you have the necessary spare parts and special equipment before starting the job.

Removing the battery

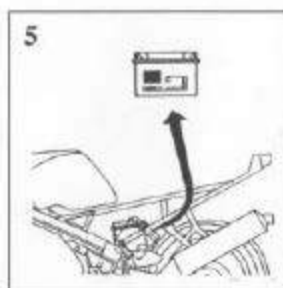
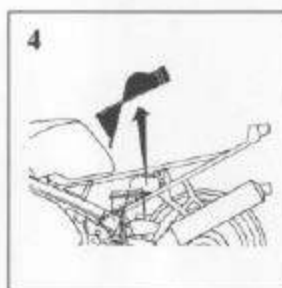
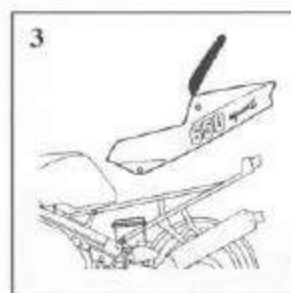
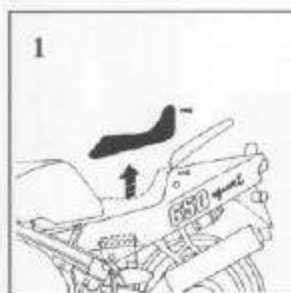

- 1 Remove the rider's saddle, unscrewing the rear screw under the pillion.
- 2 Remove the fuel cap and then the tool tray.
- 3 Remove the rear tail unit.
- 4 Remove the mudguard that covers the battery.
- 5 Slip out the battery, turning it sideways.

COMPONENTS	Page
ENGINE	A.10
VALVES	A.10
Valve timing diagram	A.10
LUBRICATION	A.10
Engine sump oil	A.10
Circuit capacity	A.10
COOLING	A.11
Cooling diagram	A.11
TRANSMISSION	A.11
Clutch	A.11
Clutch hydraulic control diagram	A.11
Gearbox	A.12
Primary transmission	A.12
Secondary transmission	A.12
INJECTION - IGNITION	A.12
Electronic injection-ignition system	A.12
Spark advance	A.13
Spark plugs	A.13
FUEL SYSTEM	A.13
CHASSIS - CYCLE PART	A.14
WHEELS	A.14
SUSPENSIONS	A.14
BRAKING SYSTEM	A.14
TYRES	A.15
Tyre pressure	A.16
DIMENSIONS	A.16
LUBRICANTS AND SUPPLIES	A.16
ELECTRIC SYSTEM	A.17

ENGINE

GENERAL CHARACTERISTICS

Type	4-stroke twin cylinder
Arrangement	front inclined forward at 20 degrees
Bore	78.5 mm
Stroke	69 mm
Total displacement	667.9 cc
Compression ratio	1:9
Max. power HP	70 HP
at speed rpm	8900 rpm
Max. torque NM	60 NM
at speed	7000 rpm
Redline	9000 rpm

CONFIGURATION

Four valves per cylinder, double overhead cam shaft (DOHC) controlled by a single central chain, acting directly on the valve tappet. Adjustment by means of a calibrated shim between tappet and valve.

Valve timing - valve clearance

Inlet	Opening	39° before TDC	(37°)
	Closing	78° after BDC	(78°)
Exhaust	Opening	74° before TDC	(49°)
	Closing	30° after TDC	(51°)

Cammes clearance starting from engine n. 1546 between brackets.

Valve diameter	Inlet	30.6 mm
	Exhaust	27.4 mm
Valve lift	Inlet	9 mm
	Exhaust	8.5 mm
Valve clearance	Inlet	0.20 / 0.25 mm
	Exhaust	0.30 / 0.35 mm

The tappet clearance is measured when the engine is cold.

LUBRICATION

Engine sump oil

Forced lubrication with gears, gauze on scavenge. By-pass valves sprung for pressure regulation. Interchangeable cartridge on delivery with safety valve against clogging.

Circuit capacity:	4 lt
Pump flow rate	1.5 lt/min. at 1000 rpm
Grade	SW - 50

COOLING

Mixed air/oil with pumped oil circuit by means of a gear pump, the cooling circuit on the head is by means of oil passages close to the combustion chamber and oil sprayers on the piston skirt. Two oil coolers situated alongside the engine contribute to the cooling of the oil in the system.

Cooling diagram

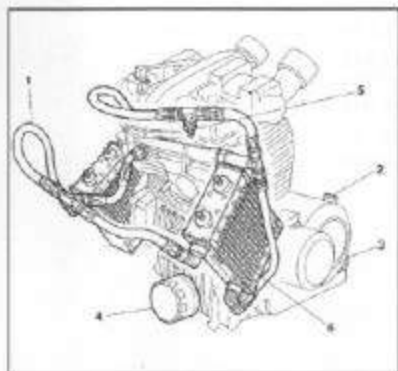

- 1 - Oil pipe fitting
- 2 - Oil filling cap
- 3 - Sight glass
- 4 - Filter
- 5 - Temperature sensor
- 6 - Oil coolers (2)

TRANSMISSION

Clutch: Multiple plates in an oil bath with 8 driving and 9 driven plates. Motorcycles with serial number up to 1461: 7 driving and 8 driven plates. The clutch is operated by a hydraulic control system.

Clutch hydraulic control diagram

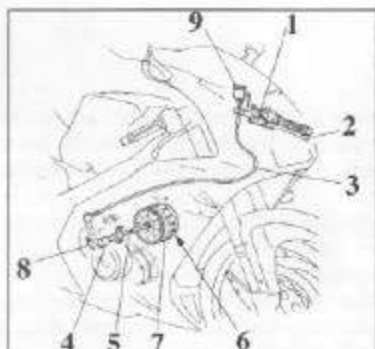

- 1 - Clutch master cylinder
- 2 - Clutch lever
- 3 - Connecting pipe
- 4 - Thrust piston
- 5 - Push rod
- 6 - Pressure plate
- 7 - Clutch gasket
- 8 - Bleed nipple
- 9 - Fluid reservoir

Gearbox: 6 ratios with constant mesh gears; control pedal on the left of the vehicle.

Primary transmission:

Engine pinion	Z 29
Clutch crown gear	Z 77
Drive ratio	2.655

Drive ratios

Gear engaged	Z gears	Total ratio	Speed km/h
1st	39/18	14.38	67
2nd	34/23	9.812	98
3rd	30/27	7.375	130
4th	27/30	5.974	161
5th	25/32	5.185	186
6th	23/34	4.490	215

Secondary transmission:

Gearbox output pinion	Z 16
Rear crown gear	Z 40

Secondary drive chain

Make	Regina
Type	135-ORS
Dimensions	5/8"
No. links	110

INJECTION - IGNITION

Make	WEBER
Type	I.A.W. 44DCFD
No. injectors per cylinder	1.0

WEBER injection-ignition system (I.A.W.)

The WEBER injection-ignition system is of the "alpha/N" type in which the engine speed and the throttle position are used to measure the quantity of air taken in; when the quantity of air is known, the amount of fuel metered according to the engine requirements. Other sensors in the system allow correction of the basic strategy in particular working conditions.

The quantity of air taken in by each cylinder, for each cycle, depends on the density of the air in the inlet manifold, on the unit displacement and on volumetric efficiency. As regards volumetric efficiency, this is established during engine research and development test throughout its entire operating range.

The control of the cylinder injectors is of the "phased sequential" type, that is the injectors are controlled according to the intake sequence, while delivery for each cylinder may begin when the intake stage starts.

The delivery timing is stored in a map in the electronic control unit.

The ignition is of the type with static inductive discharge with dwell control in the power module (COIL) and advance curves stored in the electronic control unit.

Spark advance 0°

(fixed up to 950 rpm, then the control unit varies the value according to the signals received from the sensors.)

Composition of the system components.

- | | |
|---|---------------------------------------|
| 1 - Electronic control unit | 2 - Power module (one per cylinder) |
| 3 - Control relay for injectors and ECU | 4 - Pump control relay |
| 5 - Connector for IAW system diagnosis | 6 - Throttle potentiometer |
| 7 - Oil temperature sensor | 8 - Motor crankshaft position sensor |
| 9 - Engine revs sensor | 10 - Air temperature sensor |
| 11 - Injectors (one per cylinder) | 12 - Absolute pressure sensor |
| 13 - Electronic ignition bimodule | 14 - Ignition coil (one per cylinder) |
| 15 - Petrol pump | 16 - Key commutator |

Spark plugs

Make	CHAMPION
Type	RA4HC
Distance between the electrodes	0.6 mm

FUEL SYSTEM

The fuel system is closely connected with the injection system and is characterized by the fuel tank located under the saddle. The components of the fuel system are located inside the tank and are therefore not visible from outside.

Important: the motorcycle has been designed and built for use only with **UNLEADED PETROL**.

The system is composed of: (A)

- 1 - Fuel pump
- 2 - Fuel filter
- 3 - Fuel filling cap
- 4 - Breather valve
- 5 - Fuel warning light

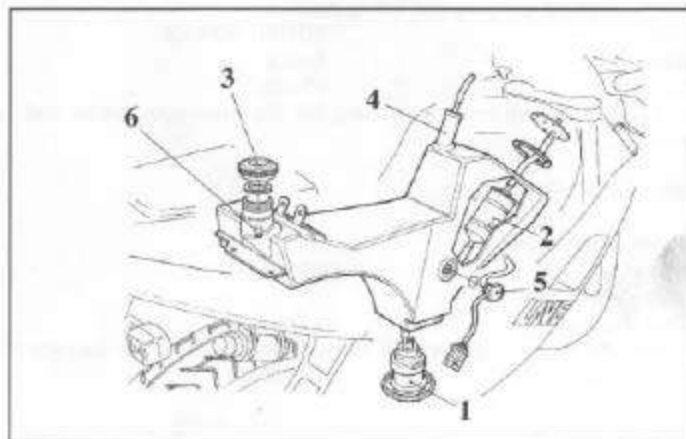

CHASSIS - CYCLE PART

Extruded light alloy 7003 tubular section. Removable light alloy rear frame.

Trail	103 mm
Castor	26°
Steering angle	26°DX7R.H. - 26°SX7L.H.

WHEELS

Light alloy rims with three spokes

Front

Make	MARCHESINI
Dimensions	3.50 x 17"

Rear

Make	MARCHESINI
Dimensions	5.50 x 17"

SUSPENSIONS**Front**

Upside-down hydraulic fork with external regulation of both rebound and bump damping of the hydraulic brake.

Make	WHITE POWER
Type	EBS 92 RO
Liner diameter	40 mm
Travel	120 mm
Oil capacity per leg	0.500 lt

Rear

Progressive suspension with swinging light alloy fork, oleopneumatic monoshock-absorber with adjustable rebound, bump damping and spring preload.

Make	WHITE POWER
Type	SA/CC
Travel	65 mm

For greater smooth running and long life, the articulations of the fork and the suspension linkages turn on roller cages.

BRAKING SYSTEM**Front** (page 15-A)

Make	BREMBO
With double steel disc	
Disc diameter	320 mm
Control by means of a lever and hydraulic pump located on the right of the handlebar.	
Pump make	BREMBO

Pump cylinder diameter 16 mm
 Calipers with four differentiated pistons
 Make BREMBO
 Type P4 30/34 "Gold Series"
 Braking surface 12.5 sq. cm.
 Friction material FREN-DO 222

Rear (B)
 Make BREMBO
 With single steel disc
 Disc diameter 245 mm
 Control by means of a lever and hydraulic pump.
 Pump make BREMBO
 Pump cylinder diameter 13 mm
 Caliper with differentiated pistons
 Make BREMBO
 Type P2 "Gold Series"
 Braking surface 12.5 sq. cm.
 Friction material FREN-DO FD 72GG

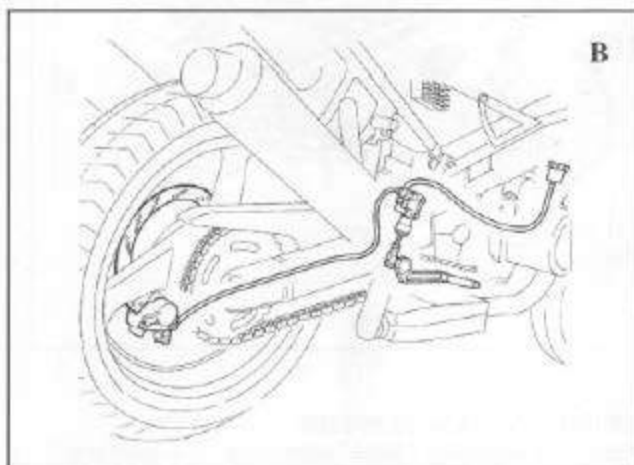

B

TYRES

Front
 Radial tubeless type.
 Make
 Type
 Dimensions

PIRELLI
 Dragon
 120/70"

Rear

Make	PIRELLI	
Type	Dragon	
Dimensions	170/60"	

Tyre pressure:

Inflation pressure	bar	kg/cm ²
Front	2.2	2.24
Rear	2.5	2.55

DIMENSIONS

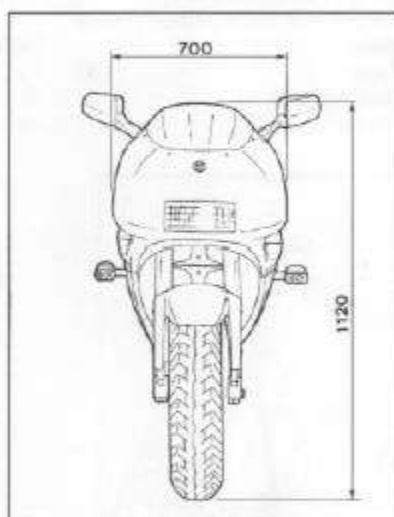
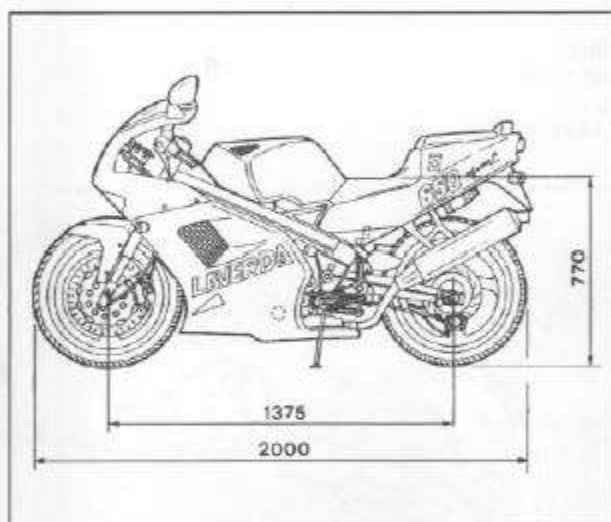

LUBRICANTS AND SUPPLIES

Petrol tank (including 3 litres fuel reserve)
 Engine sump and filter
 Front suspensions (each leg)
 Brakes circuit and clutch control
 Secondary drive chain
 Protection for electric contacts
 Speedometer transmission cable
 and gas/starter cable
 Steering pin bearings
 Tightening screws and bolts

TYPE

Unleaded petrol
 AGIP 4T Super Racing
 W.P. REZ SAE 7.50.
 AGIP Brake Fluid DOT 4
 AGIP Rocol Chain Spray
 AGIP P1 160 Spray
 AGIP F1 Grease 30
 AGIP GR MU3 grease
 AGIP GR SM grease

QUANTITY

16 lt.
 3.5 lt.
 500 lt.

ELECTRIC SYSTEM

The entire electric system is equipped with special watertight connectors, materials and components with a high degree of reliability and resistance.

The main components are:

Headlamp with single projector and halogen lamp	12V - 55/60W
Tail lamp with service light and brake light	12V - 5/21W
Direction indicators	10W
Dashboard with pilot lights and instrument lights	12V - 2W
Horn	
Electric controls on the handlebar	
Battery	12V - 18 Ah
Alternator	12V - 350W
Starting motor	12V - 0.4 kW
Fuses	15A

The fuse box is located under the rider's saddle. The fuses may be checked and changed if necessary by removing the protective cover (A).

Relays

The relay boxes are located under the rider's saddle and the pillion. The relays may be checked and changed if necessary by removing the protective covers (B and C).

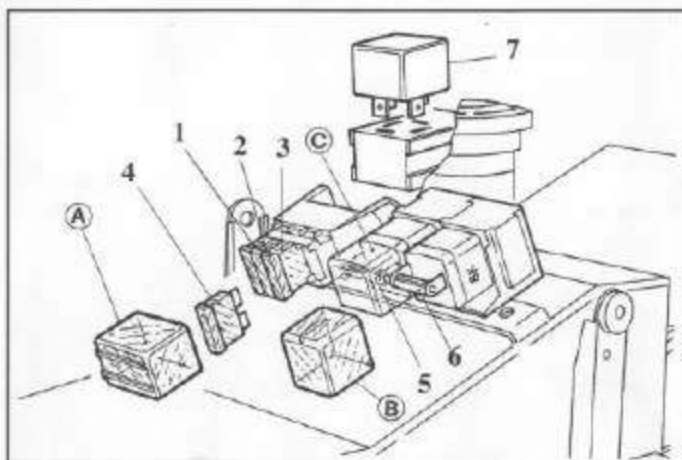

Fuses

- 1 - Lights power
- 2 - Various services
- 3 - Injection power
- 4 - Side stand fuse

Relays

- 5 - Control unit power
- 6 - Fuel pump power
- 7 - Stand switch

SERVICING OPERATIONS

General recommendations	B.20
Changing the engine oil and filter	B.20
Adjusting the chain	B.20
Checking the tyre pressure	B.20
Checking the fastenings	B.21
Checking the fluid level in brakes and clutch	B.21
Routine servicing	B.22
Routine servicing	B.23

SERVICING OPERATIONS

General recommendations

Laverda recommends regular check-ups based on a table of distances or minimum periods. More frequent overhauls are needed on motorcycles used in particularly harsh conditions, dusty or hot atmospheres, frequent use in city traffic, habitual use of the motorcycle at maximum performance, etc. Below are described some of the servicing operations listed above. Further information may be found in the specific paragraphs.

Changing the engine oil and filter

Allow the engine reach its normal operating temperature, then proceed as follows:

- Remove the bottom of the fairing.
- Remove the filling cap (D).
- Unscrew the sump cap (A).
- Remove the oil and let it drain off for a few minutes.
- Replace the oil cap.
- Remove the filter cartridge (C) and change it.
- Fill with oil up to the level.
- Check the oil level on the sight glass on the left casing (E), ensuring that it reaches the MAX mark.

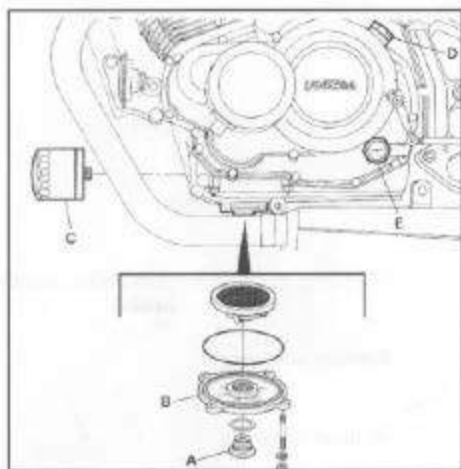

Checking and adjusting the tension of the secondary drive chain

To adjust the chain tension (A), the nuts holding the rear wheel (1) must first be loosened; unscrew the nut (3) and then turn the screw (2) until the right tension is achieved.

Now tighten the wheel nuts again, checking that the data correspond to those on the adhesive plate on the rear fork (4). When measuring the tension, the values given in figure 'B' must be considered.

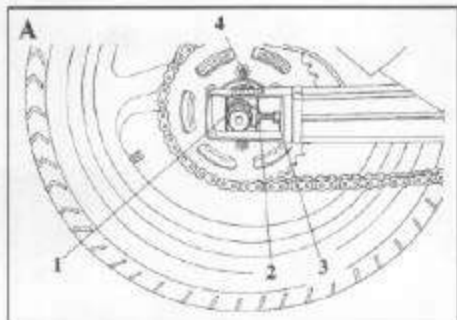

Checking the tyre pressure (when cold)

Use a good pressure gauge (page 21 - A). Inflate both the tyres to the correct pressure:

- | | | |
|-----------------------|-----------|------------|
| - rider only | Front 2.2 | - Rear 2.5 |
| - rider and passenger | Front 2.3 | - Rear 2.6 |

Check the general conditions of the tyres. Inspect the wheels, ensuring that they are not deformed, dented or cracked. The alignment and balancing of the wheels are also very important.

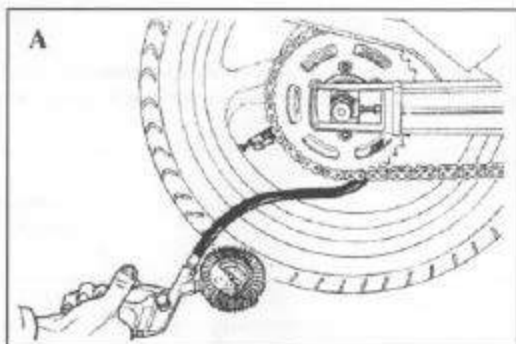

Checking the fastenings

Check in particular: the two wheel spindles, the footrest, the brake calipers and the exhaust fastenings.

Checking the fluid level in brakes and clutch

There are three fluid tanks: two on the handlebar (clutch and front brake - B) and one behind the right side of the fairing (rear brake - C). There are MAX and MIN marks on the tanks; the fluid level must clearly be between these two marks, preferably closer to MAX.

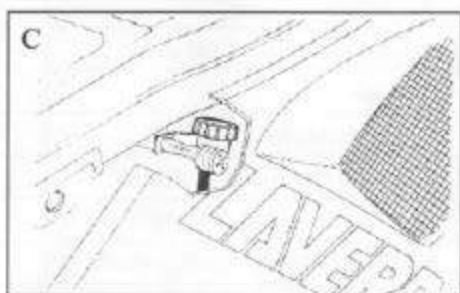
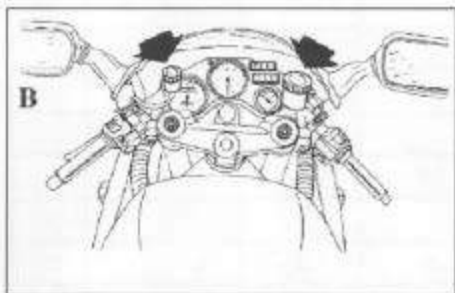

WARNING - Use only new fluid. Hydraulic fluid can spoil paint and clothing. Do not clean with alcohol or compressed air.

Routine servicing chart.

On the following page is a table indicating the routine servicing operations for correct use of the motorcycle. The operations indicated should be followed scrupulously, since the working life of the motorcycle, its safety and the pleasure that it gives the rider depend largely on the respect of these precise rules.

IMPORTANT: Always observe scrupulously the indications and distances given.

ROUTINE SERVICING

The table below lists the recommended intervals for all the servicing operations necessary to keep the motorcycle running at maximum performance and economy.

Operations	Operation symbol	Pre delivery	After the first.....	Every...		
			1000 Km	1000	10000	20000
Engine oil level	C	Δ		Δ		
Engine oil	*S		Δ		Δ	
Engine oil filter	*S		Δ		Δ	
Engine oil inlet filter	*P		Δ			Δ
Head tightening	*C		Δ			
Valve clearance	*C		Δ		Δ	
Cam chain	*C		Δ		Δ	
Changing the cam chain	*S					Δ
Spark plugs	C/S		Δ		Δ	
Fuel filter	*S				Δ	
Throttle body: timing and idling	C/P		Δ		Δ	
Air filter	P/S		Δ		Δ	
Cylinder compression	*C		Δ		Δ	
Brake and clutch control oil level	C	Δ	Δ	Δ		
Changing brake and clutch fluid	*S					Δ
Brake and clutch hydraulic controls	*C	Δ	Δ	Δ		
Engine controls	*C/V	Δ				
Dashboard instruments	*C/V	Δ				
Lights and signals system	*V	Δ				
Headlamp position, locks and hinges	*C	Δ				
Battery charge	*C	Δ				
General cleaning	*P	Δ				
Testing the motorcycle	*C	Δ	Δ		Δ	
Flexible controls	C/L	Δ	Δ	Δ		

Tyres: wear and pressure	C	Δ	Δ	Δ		
Steering bearings clearance	*C	Δ		Δ		Δ
Chain tension and alignment	C		Δ	Δ		
Secondary drive	*C	Δ	Δ	Δ		
Brake pads wear	*C/S		Δ		Δ	
Wheel hub bearings	*C					Δ
Rear wheel flexible coupling	*C		Δ			Δ
Fuel tank	*P					Δ
Changing the oil in the front fork	*S					Δ
General tightening of nuts and bolts	*C	Δ	Δ			Δ
Lubrication and general greasing	*L		Δ		Δ	
Checking level of electrolyte in the battery	C		Δ	Δ		

Operation identification symbol

- * This symbol indicates that it is recommended that this operation is performed by a qualified Laverda workshop
- C** Check and adjust
L Lubricate and/or grease
P Clean
S Change
V Check with motor running

ADJUSTING AND REGULATING

Adjusting the cam chain	C.26
Checking valve clearance	C.27
Set of valve shims	C.29
Valve timing	C.31
Adjusting the throttle body	C.32
Checking electrolyte in the battery	C.34
Changing and cleaning the air filter	C.35
Adjusting the secondary chain	C.36
Adjusting the front fork	C.37
Adjusting the shock absorber	C.37
Changing the brake and clutch fluid	C.38

ADJUSTING AND REGULATING

Adjusting the tension of the cam chain

To perform this operation, proceed as follows:

- Remove the head cover, loosening the 15 allen screws but leaving them in their slots; at the same time disconnect the wiring of the electronic sensor.
- Remove the spark plugs, the round inspection cover PK on the left side of the casing, and turn the motor shaft with the key **0610080020** until the length of cam chain between the gears of the camshaft is as slack as possible; this occurs when, as in fig. 'A', the inlet cams of the left cylinder are about to leave the tappets - at end of inlet - and the exhaust cams of the left cylinder have just started to leave the tappets at end of exhaust.
- At this point turn the chain tensioner, after having released the locknut (B), so that, when the chain is pressed with a finger, it sags 5 mm with a load of about 5 kg. (C-D). This must be checked when the engine is cold. Lock the tensioner bolt with the lock nut reassemble the various components.

Note: when the screw of the chain tensioner is completely screwed in the chain must be changed.

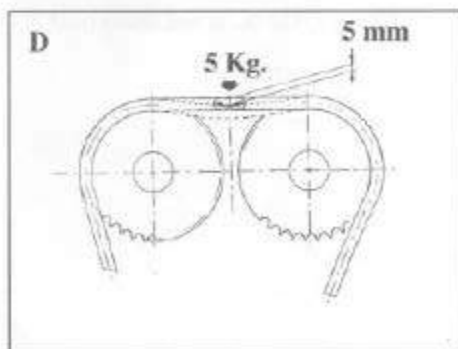
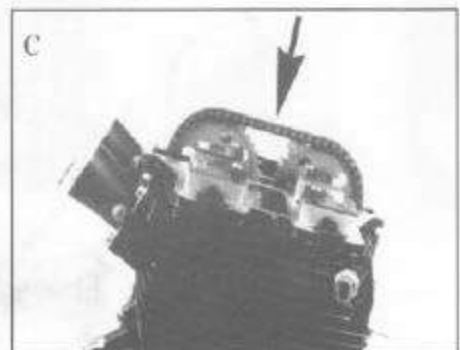
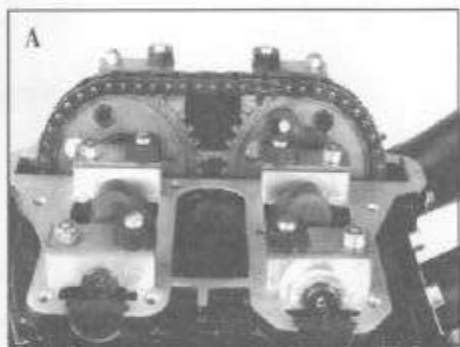

Checking valve clearance

This is the most demanding servicing job and also one of the most delicate ones to perform on the Laverda 650.

Note: It will be necessary to have a selection of spare shims in case incorrect clearance is found (shims kit code no. 05500500037).

- Let the engine cool down completely. Ensure the engine is cold.
- Remove the filter cover and loosen the 15 allen screws, leaving them in their slots in the cover (A),
- Check that the head nuts are tight.
- Remove the spark plugs and the round inspection cover PK on the left side. Turning the rotor PK with the key 06100800020, turn the motor shaft in an anti-clockwise direction until the lobes of the camshafts are facing in the direction opposite the tappet.
- Using a feeler gauge, check the clearance of the valves of the cylinder with the piston at TDC; repeat the operation with the four valves on the other cylinder after having brought its piston to TDC at the end of the compression phase: the blade of the feeler gauge must enter between the cam and the tappet below it with a slight friction (B).

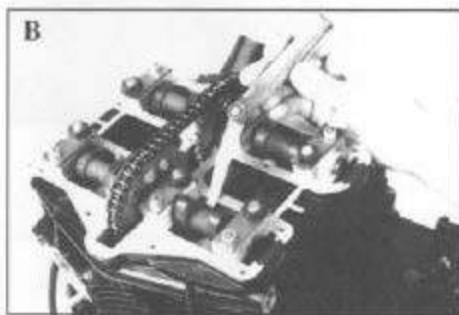

To measure the clearance precisely, use a feeler gauge with blade sizes 0.10 - 0.20 - 0.30 ... 1.0 mm, combining them, if necessary, with other blades of intermediate sizes 0.05 - 0.15 - 0.25 mm etc.

The recommended clearance is 0.20 mm at inlet and 0.30 mm at exhaust.

On a sheet of drawing paper, make a clear sketch of the cylinder head and mark the clearance found next to each valve.

If irregular clearance is found on one or more valves, the respective calibrated shims must be changed, proceeding as follows.

Turn the motor shaft with the tool **06100800020** inserted in the bush PK (A) until the joining link of the cam chain is between the two camshaft sprockets; then split the chain, removing the piece of string steel wire after having straightened or cut it (in the latter case wrap it in rags to prevent pieces of wire from falling into the engine. see B).

Before removing the link it is advisable to tie two pieces of metal wire to the two ends of the chain and fasten them to the casing so that the chain cannot fall into the engine.

Lightly slacken the two nuts joining the head and cylinders, one of which is between the exhaust pipes, the other between the inlet manifolds (C).

Unscrew the nuts on the studs holding the head, following the order indicated (D) which is the inverse of the tightening procedure.

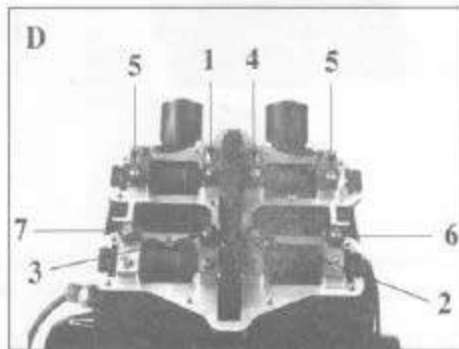
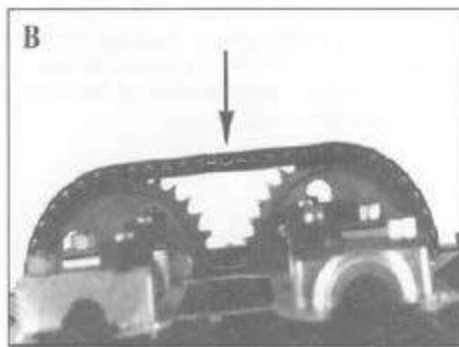
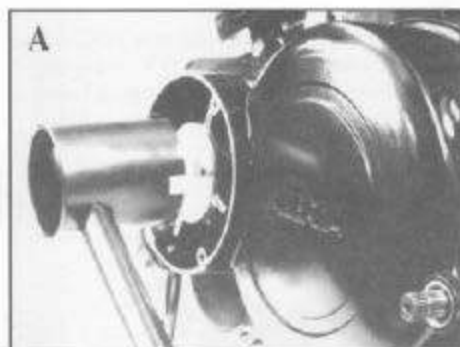

Remove the camshaft for the valves to be adjusted, unscrewing the cap fixing nuts. Be sure not to mix up the caps and plates which are marked with reference numbers from 1 to 8.

- Using pliers or a magnet, slip out the tappets of the valves to be adjusted without mixing them up (A), then measure with a micrometer gauge the thickness of the calibrated shim at the top of the valve stem so as to choose a new shim of the correct thickness (B).

The recommended clearance is 0.20 mm at inlet and 0.30 mm at exhaust.

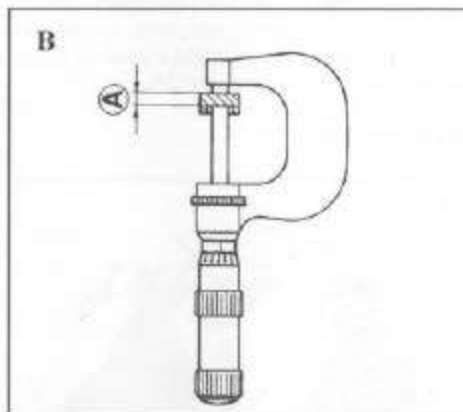
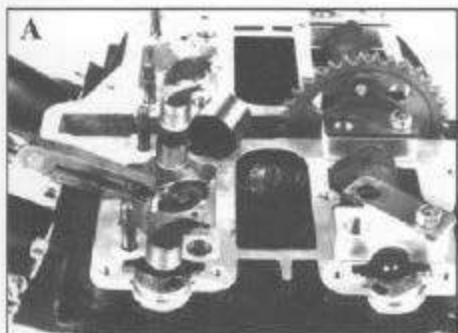

Set of valve shims

Shims available for adjusting valve clearance

- Valve shim thickness 1.93
- Valve shim thickness 2.00
- Valve shim thickness 2.07
- Valve shim thickness 2.15
- Valve shim thickness 2.23
- Valve shim thickness 2.30
- Valve shim thickness 2.38
- Valve shim thickness 2.45
- Valve shim thickness 2.52
- Valve shim thickness 2.60
- Valve shim thickness 2.70

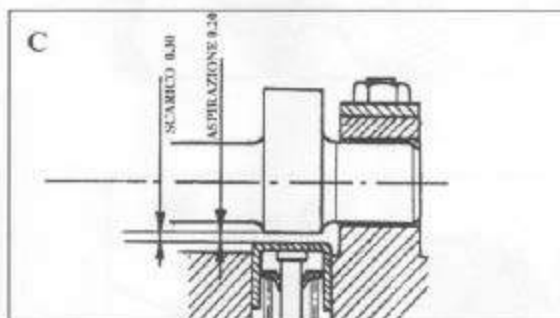

Example: if the clearance measured with a feeler gauge is 0.30 mm instead of 0.20 mm, with an extra difference of 0.10 mm, the thickness of the new shim will be formed by the thickness of the old shim plus the measured difference of 0.10 mm.

- Put the new shims into position then, after putting its own tappet onto each valve, reassemble the camshaft, the caps and the plates; during reassembly, check the exact positioning by matching the reference numbers stamped on the caps (page 30 - A).
Tighten the four external nuts that fasten the caps with a torque wrench at 1.4 - 1.5 Kgm.

The four retaining nuts inside the head (with a thread of 11 mm) which also fasten the caps must be tightened with a torque wrench using a 17 mm socket, crossing over several times and following the order indicated in fig. 'B'. (For example, tighten all the nuts, following the order indicated, at 1.5 Kgm, then again at 3 Kgm to reach a final torque value of 4.5 Kgm. It is also advisable to go over them several times.) Lastly tighten the two nuts at front and rear of the cylinder head coupling (C).

- Check that the camshafts can turn without abnormal friction (the camshafts can be turned with an 11 mm spanner placed on the retaining bolts of the chain gear). Check the clearance of each valve again, ensuring that it is as calculated and required. If the valve clearance is correct, set the valve timing (see: timing the distribution). Close the chain again, inserting a piece of string steel wire (diam. 1.2 mm, length 20 mm) in the joining link and bending it with the pliers (D).

Replace the cover, etc.

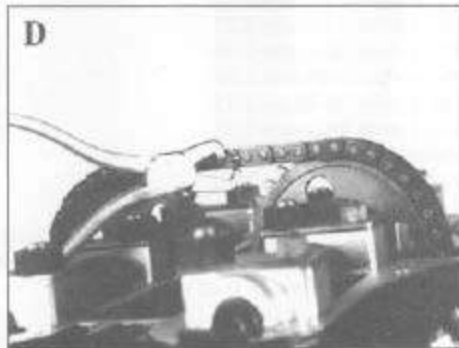
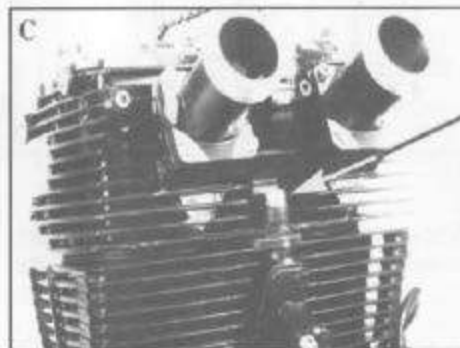
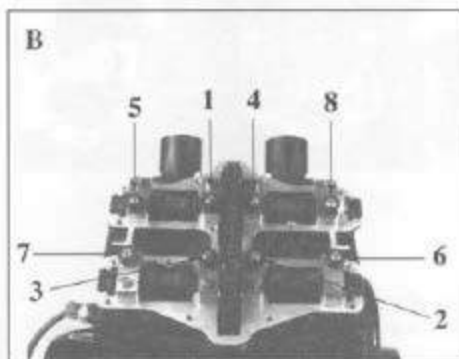
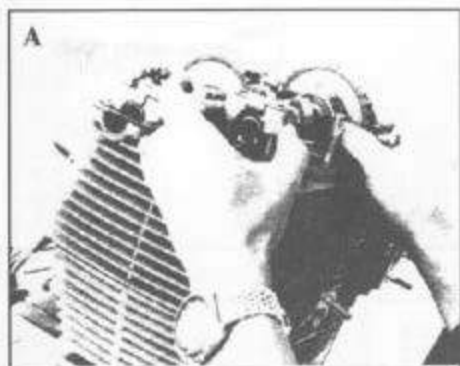

Setting the valve timing

The valve timing is correct when, with the left piston at top dead centre (TDC), the marks of the two gears of the camshafts are aligned with the marks on the central caps. Check TDC with a comparator using the special tool 061008V17901 (A) screwed into the place of the spark plug on the left cylinder.

Warning: when fitting the chain on the central crankshaft pinion of the engine, check that this condition occurs: with the left piston at TDC, the two lengths of the chain which is wound onto the pinion at the bottom, lifted up vertically, must be the same length.

Proceed as follows:

1) Bring the left piston to TDC turning the engine shaft in an anti-clockwise direction, with the special tool 061008000020 inserted in the bush PK until the mark on one of the pins of PK is lined up with the mark on the casing (B).

2) Turn the camshafts until the marks on the gears are lined up with those on the caps (C). To do this use an 11 mm spanner on the retaining bolts of the camshaft sprockets.

3) If the instructions have been followed, the split in the chain will be approximately between the two gears, so it will be easy to fit the joining link, bending the piece of string steel wire inserted in the link with pliers (D).

4) It is important to check that the valve timing is correct also after adjusting the tension of the cam chain: if necessary repeat the timing operation without altering the adjustment of the chain tensioner which is now correct.

Errors in timing may be made when fitting a chain that has been stretched by prolonged use on the gears of the camshafts, when the tensioner is not in place or when its adjusting bolt is completely slack.

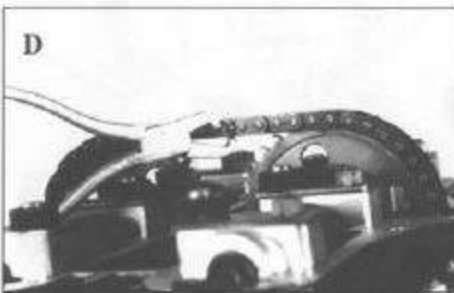
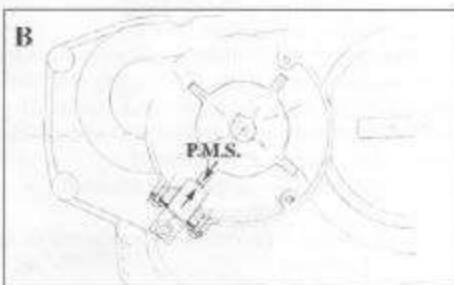
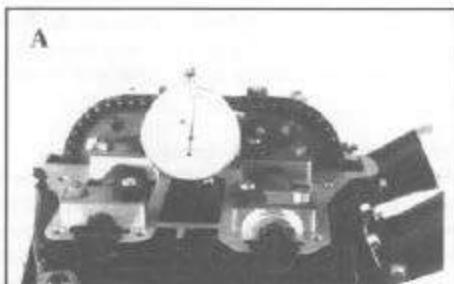

Note: unless it is completely necessary, do not remove the sprockets from the camshafts. If it is unavoidable, mark them so that you are sure to put them back in the same place. Ensure that any new sprockets have their marks facing in the same way as the old ones with respect to the teeth and fastening holes.

Adjusting the throttle - Injection unit

As it controls all the supply functions and the emission of exhaust gas, the throttle is a very important component for managing power, ease of use and pollution. The throttle body is pre-set, during production, with inspection and specific constant calibration. Each element is an integral part and must work in perfect harmony with all the other elements of which the unit is composed.

The main operations required for correct adjustment are the following:

- position of the throttle potentiometer (indicates the exact position of the throttle valve)
- adjustment of the fuel-air mixture at idling speed
- balancing of the air flow rate.

The richness of the mixture at idling speed is an important parameter governed by nearly all international anti-pollution regulations. To comply with these regulations the mixture will tend to be "poor" (values of about 1.5% CO); on the other hand, the need for better general driving power will require a mixture with a percentage of between 4 and 6% CO. Since this type of motorcycle is also used for competition riding, the latter values should be considered.

To perform adjustment the tools required are:

- a digital voltmeter;
- a normal vacuummeter with mercury columns;
- a CO tester.

Proceed as follows:

- Remove the filter cover;
- completely close the throttle valve on the inlet manifold, turning the register screw (A-1);
- unscrew it until the throttle is resting on the body. Check this condition by pulling the throttle lever repeatedly;
- remove the saddle and the tail piece to gain access to the control unit located at the rear of the saddle support frame (B).

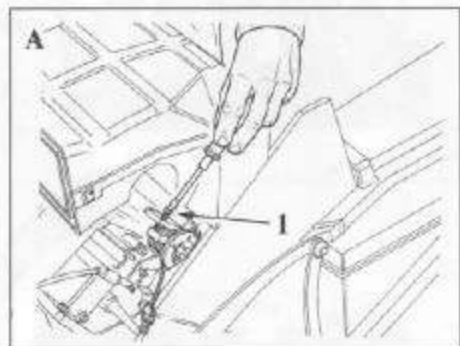

- remove the external protection of the electronic injection control unit contact board after having removed the retaining screw (A-2);

- remove the clamp and slip off the external protection of the contact board; replace the contact board in the control unit;

- connect the voltmeter to the register pin no. 11 (-) and to pin no. 17 (+). With the ignition key in ON position, check that the voltage is 150 mV +/- 5 mV. If the value is incorrect, slacken the retaining screws of the potentiometer (B-3) and turn it until the required voltage is obtained (to do this it is necessary to force the throttle valve gently in closing position), then tighten the screws;

- tighten the register screw until a voltage of 300 mV +/- 15 mV is obtained;

- connect the vacuumeter to the intake manifolds after having removed the screw that closes the instrument connector fitting hole (C);

- start the engine and bring it to using temperature after having removed the caps, close the by-pass screws completely (D-1);

- bring the idling speed to 1,100 rpm, turning the by-pass screws (D-1), then balance the air flow rates;

- insert the probe of the CO tester in the exhaust pipes and adjust the cylinder CO content; if the percentage found is not within the established values, adjust the trimmer (A-1) on the control unit after having removed the protection cap; the trimmer acts as a mixing screw: unscrew for a richer mixture, screw down for a poorer mixture.

Performing the operations illustrated in sequence may alter the result of the previous ones; it is therefore necessary to reach the best possible compromise in this situation;

- balanced air flow rate;

- CO percentage between 4 and 6%;

- idling speed 1,100 rpm.

Ensure that spark plugs are acethed otherwise ignition system could be irreparably damaged.

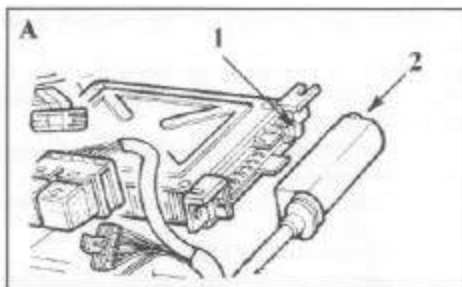

Checking and topping up the electrolyte in the battery

The battery is located on the left part of the saddle support frame in a special housing; to **remove** the battery, proceed as follows:

- Remove the rider's saddle, unscrewing the rear screw under the pillion.
- Remove the fuel filling cap and then the tool tray.
- Remove the rear tail.
- Remove the mudguard that covers the battery.
- Slip out the battery, turning it sideways.

The above operations are illustrated on page 7.

With transparent batteries it is possible to check the level from outside: the electrolyte must be between the MIN and MAX marks.

If the electrolyte level is low, top up with distilled water.

Ensure that the battery electrolyte breather pipe does not leak any acid into a place where it could damage the paintwork.

Clean the two battery terminals, tighten the clamps and grease them lightly with Vaseline.

Note: It is preferable to let the battery cool for at least 6 hours before checking it.

Adjusting the throttle control rotation clearance

The throttle control must have a clearance of 2° - 3° in the control grip (A-1/2). To adjust the clearance you can turn the register located at the start of the transmission cable (A-3) or adjust the register screw close to the throttle body (B-1).

- Adjust the starter control cable in the same way with the register provided (B-2).
- Lubricate the gas control and starter cables in the usual way.

Changing the engine oil

Cleaning the mesh filter and changing the filter cartridge.

As well as the usual cartridge filter located at the front of the engine, the following must also be attended to regularly:

- Clean and check the mesh filter under the engine close to the oil drainage cap (C-1).
- First unscrew the cap and drain off the oil (C-2).

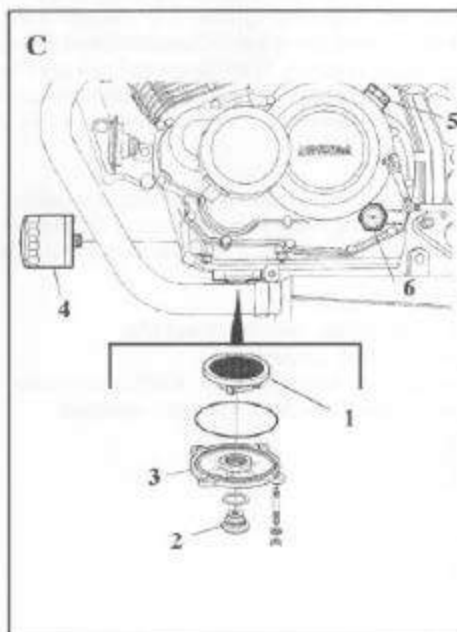
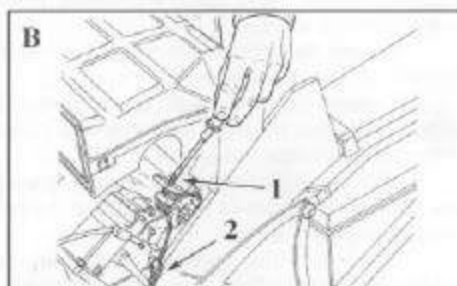
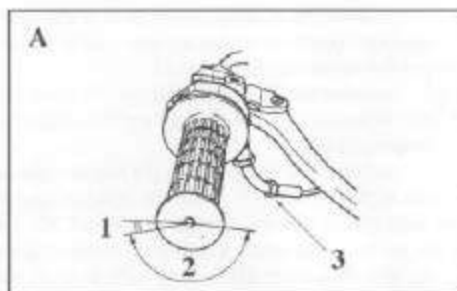

- Let the engine oil drain off.
 - Remove the filter-holding flange (C-3), unscrewing the four screws, and drain the mesh filter.
 - Once the filter has been removed it must be cleaned completely with degreasing fluid and reassembled. The filter is sealed with an O-ring which must be changed every three operations.
 - Now unscrew the filter cartridge and replace it with a new one (C-4).
 - Unscrew the filling cap (C-5) and fill up with oil of the recommended type as indicated in the SUPPLIES table, up to the Max level shown on the indicator (C-6).
- Perform this operation when the engine is warm.

Changing and cleaning the air filter

The air filter must be changed according to the indications on the routine servicing table.

To gain access to the air filter, proceed as follows:

- remove the filter covering casing
- slacken the grip of the hooks at the side of the filter box (A)
- remove the cartridge (B) and clean it or change it, depending on the indications given on the routine servicing table.

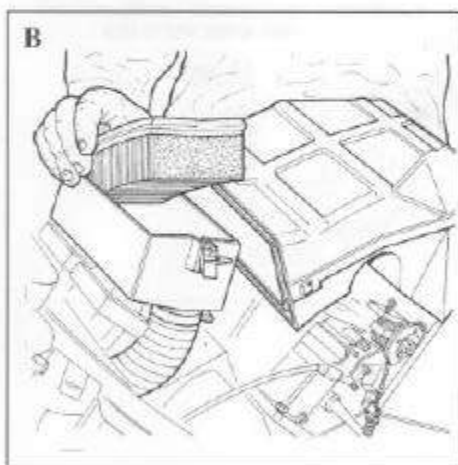
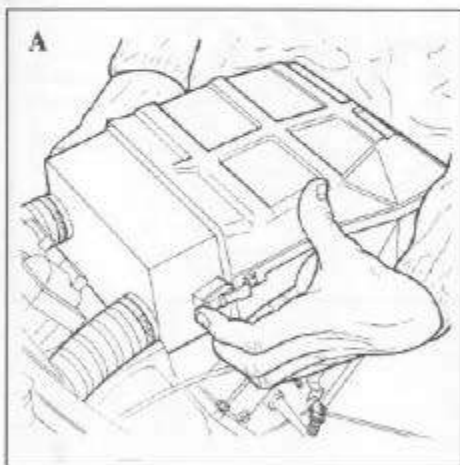

Checking and adjusting the drive chain tension

If possible, place the motorcycle on a central stand that holds the rear wheel up off the ground and check the lower chain clearance; with the wheel free and the motorcycle completely unloaded, the clearance must be as indicated in figure 'A'.

If necessary, adjust the chain tension proceeding as follows:

- slacken the nuts that secure the rear wheel (B-1), unscrew the nut 3 then turn the screw 2 until the correct adjustment is achieved.

At this point tighten the wheel nuts again, checking that the measurements are the same on both arms of the rear fork.

The adjustment must coincide exactly with the register marks on the top of the rear fork.

Tighten the nuts of the rear fork spindle at the prescribed torque value.

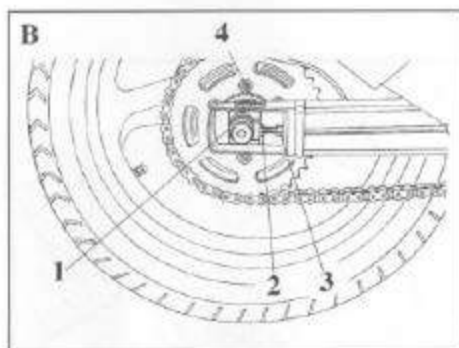

Adjusting the front fork

Both rebound and bump damping of the hydraulic brake of the front fork are adjustable.

To adjust rebound it is necessary to use the external registers located at the top of the fork stem (A).

The register must be turned to adjust the rebound of each stem. The position with the knob turned fully to the right corresponds to maximum damping. Rebound decreases as the register is turned in an anti-clockwise direction. The register has 6 click positions.

On the other hand, to adjust bump damping, use the register screw located close to the wheel spindle (B); position "1" corresponds to maximum damping.

The adjustment positions are as follows: *Rebound: 6 click positions - *Bump damping: 8 click positions.

Warning: When adjusting the front fork, as for the rear shock absorber, consider the load carried (weight of the rider, passenger, baggage, etc.) as well as the type of driving and the type of road.

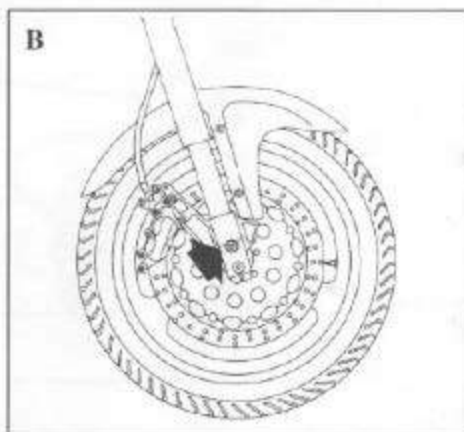
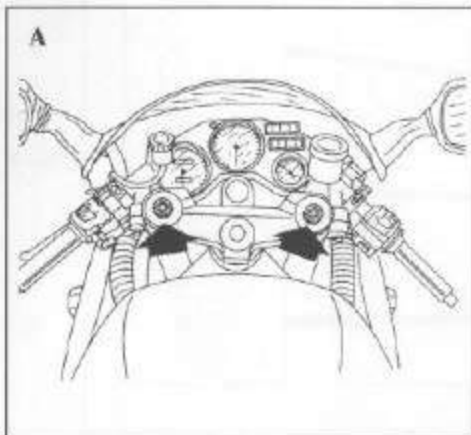

Adjusting the rear shock absorber

General rules

- Always check or adjust spring preload before changing the rebound or bump damping;
- never adjust rebound and bump damping at the same time, but always one at a time;
- check the shock absorber regularly, pay attention to any oil leakage or damage to the connectors, oil seal spring, stem or stop pad;
- check the shock absorber every 15000 km. or every year.

The rear shock absorber has adjustable rebound, bump damping and spring preload.

To adjust, use the external registers, located on the plenum chamber which is on the right side of the saddle support frame (page 38.B-1) for rebound and under the shock absorber (page 38.B-2) for bump damping. Spring preload is adjusted by turning the ring nuts (page 38.B-3), thus altering the driving position of the motorcycle.

- when turning the rebound register (external plenum chamber) there are 7 positions; position "7" corresponds to maximum stiffness;

- when turning the bump damping register there are 11 positions; position "11" corresponds to a greater braking action.

ATTENTION: when adjusting the height of the shock absorber, the maximum size of Y (A) must not be greater than 9 mm. Pay particular attention to this value as it is very dangerous.

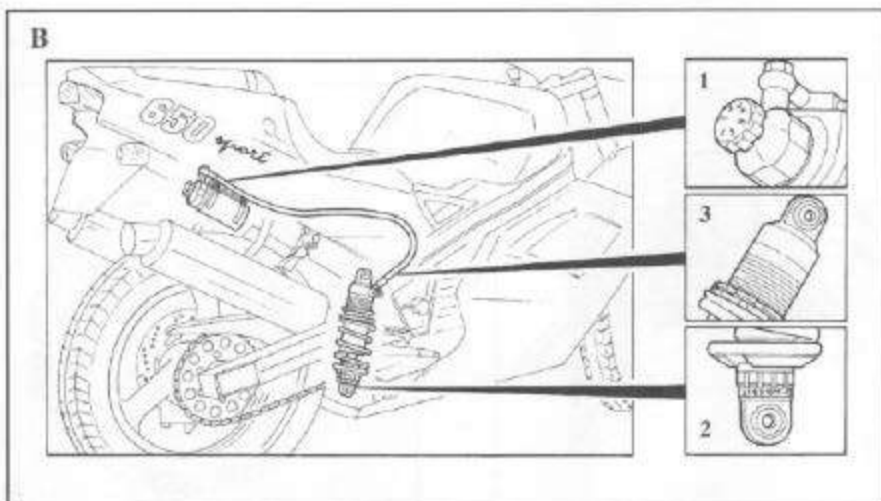
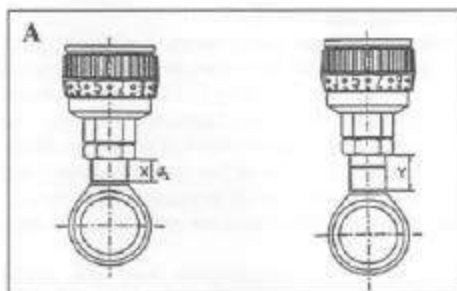

Changing the brake and clutch fluid

The brake fluid, like the hydraulic clutch fluid, must be changed regularly as indicated in the routine servicing table.

Drain off the fluid to be replaced, proceeding as follows:

- connect a rubber tube to the bleed valves (C) to prevent the brake fluid, which is highly corrosive, from damaging any parts with which it might come in contact;
- unscrew the bleed valve a few turns;
- pull the brake control lever repeatedly after having removed the cover from the fluid reservoir;
- repeat the operation for each brake caliper.

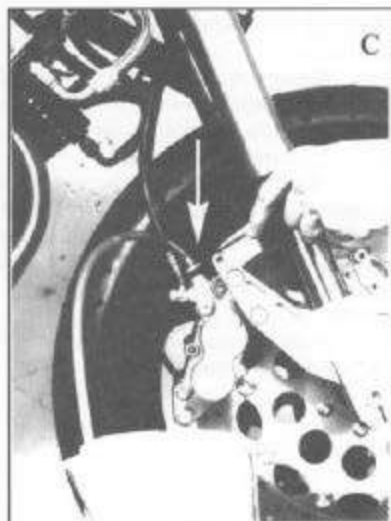

To refill and bleed the braking system, proceed as follows:

- with the rubber tubes still connected to the bleed valves, pour the brake fluid into the reservoir until the max. level mark is reached (always keep the fluid at maximum level until bleeding is completed).

To bleed the rear caliper you must remove it from the caliper support, hold it with the bleed valve facing upwards and insert a shim similar to the brake disk between the two brake pads of the caliper. Pull the brake control lever several times until it gets stiff then, keeping it pulled, open and close the bleed valve quickly. Repeat the operation until no air bubbles can be seen in the fluid coming out of the plastic tube.

The operation must be performed on one caliper at a time.

Repeat the same operations with the clutch control, connecting the bleed pipe to the connector provided (C-8).

Attention: do not use the fluid in the recovery tank. Proceed cautiously because the hydraulic fluid is **corrosive** and can spoil the paintwork.

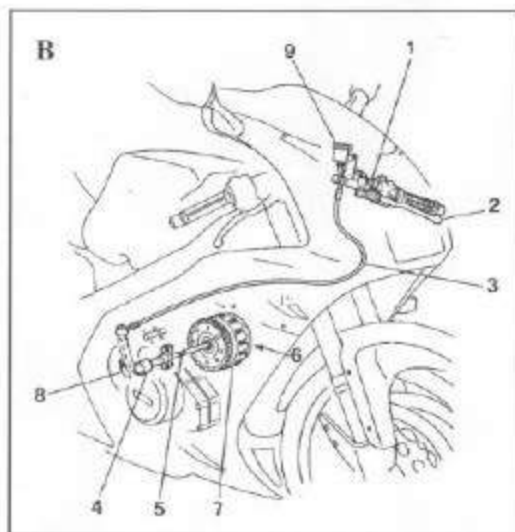



[The text in this section is extremely faint and illegible. It appears to be several paragraphs of a document, possibly a technical manual or a report, but the content cannot be discerned.]



ELECTRONIC INJECTION**IGNITION SYSTEM**

Influence of the air-fuel ratio and of the spark advance	D.42
Weber injection-ignition system	D.42
I.A.W. electronic control unit	D.43
Fuel circuit	D.44
Electric fuel pump	D.44
Electroinjector	D.45
Air circuit	D.45
Absolute pressure sensor	D.45
Air and oil temperature sensor	D.46
Coil and power module	D.46
Throttle position potentiometer	D.47
Pick-up	D.47
Operating phases	D.48
Instructions for use of the diagnosis instrument	D.48
Interpretation of the Check Lamp signals	D.49
ELECTRONIC INJECTION SYSTEM KEY	D.50
Cable colour code	D.51

ELECTRONIC INJECTION-IGNITION SYSTEM

The application of an injection-ignition system with electronic control on four-cycle engines has made their optimum use possible, giving greater specific power in compatibility with the lower specific consumption and lower quantity of unburnt elements in the exhaust gases. These advantages have been obtained thanks to a more correct dosing of the air-fuel ratio and to optimum management of the spark advance. This system is composed of three circuits: **fuel circuit, intake air circuit and electric circuit.**

Influence of the air-fuel ratio and of the spark advance

The management of the air-fuel ratio and of the spark advance is fundamental for optimum engine operation.

The air-fuel ratio is given by the ratio, in weight, of air and petrol taken in by the engine; the ideal or stoichiometric ratio is the one that gives complete combustion. Excess air or insufficient air respectively give a poor mixture or a rich mixture, which influence power and consumption (A), as well as the emission of polluting gases from the exhaust (B).

The electronic control of spark advance allows optimizing of the engine performance, maximum power, consumption and the concentrations of polluting gases in the exhaust. The electronic control of advance, together with the fuel supply control, allows better operation of the engine in all conditions of use (starting at low temperature, correct engine running speed, engine in partially choked load conditions).

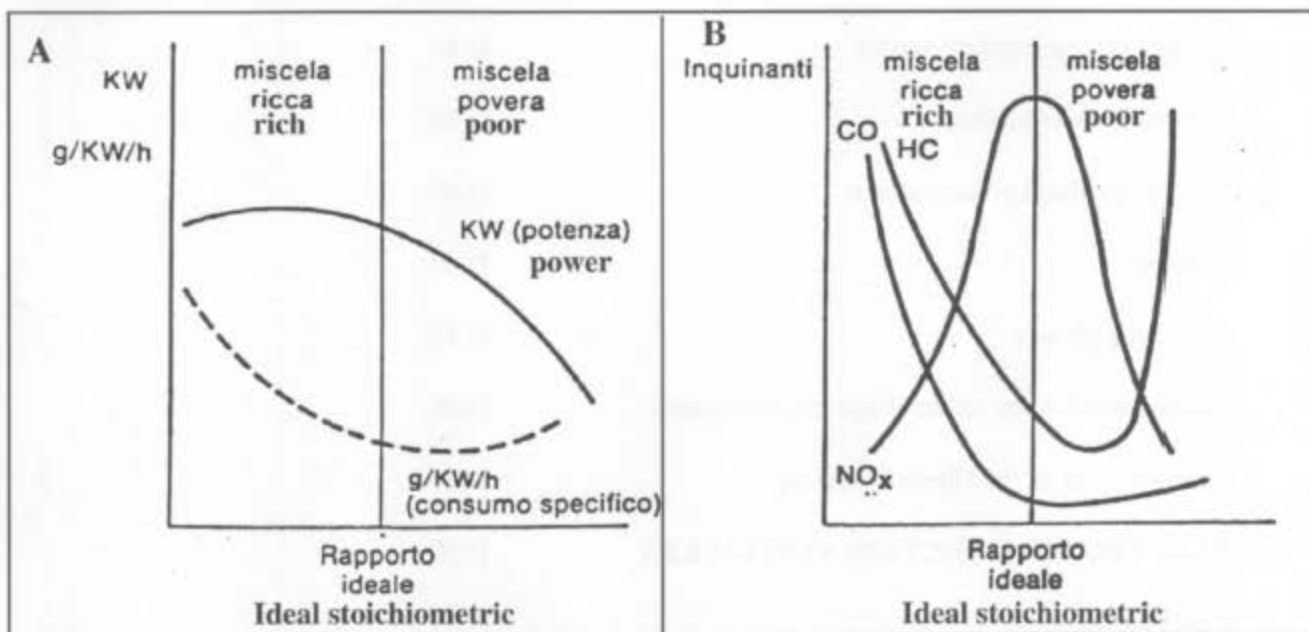

Weber injection-ignition system (I.A.W.)

The WEBER injection-ignition system is of the "alpha/N" type in which the engine speed and the throttle position are used as the main parameters for measuring the quantity of air taken in; when the quantity of air is known, the amount of fuel is dosed according to the desired blend. Other sensors in the system (phase sensor, atmospheric pressure, air temperature, oil temperature and idle speed trimmer) allow correction of the basic strategy in particular working conditions. The engine speed and the throttle angle also allow calculation of the optimum spark advance for any working condition.

The quantity of air taken in by each cylinder, for each cycle, depends on the density of the air in the inlet manifold, on the unit displacement and on volumetric efficiency. As regards volumetric efficiency, this is established on an experimental basis on the engine throughout its range of operation (engine revs and load) and stored in a map (EPROM) in the electronic control unit. The control of the cylinder injectors is of the "phased sequential" type, that is the two injectors are controlled according to the intake sequence, while delivery for each cylinder may already begin when the intake stage starts. The delivery start timing is stored in a map (EPROM) in the electronic control unit. The ignition is of the type with static inductive discharge with dwell control in the power module and advance curves stored in the electronic control unit (EPROM).

L.A.W. electronic control unit

The control unit of the injection-ignition system is a microprocessor-controlled digital electronic control unit; it controls the parameters for engine feeding and ignition:

- quantity of fuel supplied to each cylinder in sequence (1-2) at one time;
- start of fuel distribution (injection timing) for the intake of each cylinder;
- spark advance.

To calculate the above parameters, the unit makes use of the following input signals:

- absolute pressure;
- intake air temperature;
- oil temperature;
- number of engine revs and position of each cylinder with respect to TDC.;
- battery voltage - throttle position.

The control unit is fed by the 12V battery (measured between pins 1 and 20 of the terminal board on the control panel) which it transforms into 5V \pm 0.25 (pins 11-30) necessary to feed the various sensors.

The external structure and the internal circuits of the control unit are the same for all versions. The part that defines a particular mapping of the control unit is the EPROM.

This very important element may be replaced by proceeding as follows.

Lift the pillion, remove the tool box to gain access to the control unit (A), open the cover, unscrewing the four screws (A-1). Remove the EPROM (B-3) that is to be replaced.

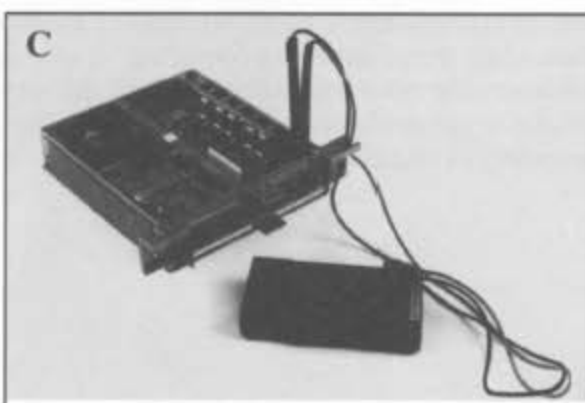
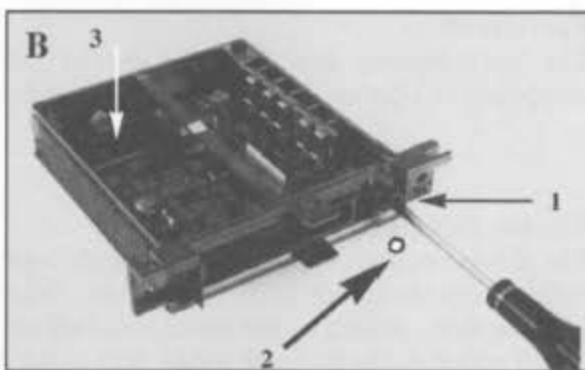

When installing the new part, pay attention to the reference mark which should be aligned with the matching mark on the base of the control unit.

The control unit is connected to the main system by means of a series of electric cables. These cables could cause malfunction of the control unit that would not be identified with the normal diagnosis procedure. To exclude these cables you must work on pin no. 20, situated on the inside of the wall that holds the connector, connecting it with a cable to the positive (+) pole of the battery. Then start the vehicle and remove the ignition key. In this way, when the elements and cables of the electric system are excluded, only the components of the injection system remain in operation. The control unit is provided with a trimmer (page 43 - B) composed of a regulating screw located behind a protection cap (page 43 - B2). With this screw you can modify the CO percentage as described in the paragraph "Adjusting the throttle control" in the chapter on adjusting and regulating.

This screw has a working phase in which the voltage goes from 0 to 5 Volt which is the max. value of feeding voltage for the control unit. To identify this phase you must remove the top cover of the control unit, leaving it connected to the system.

With the key in the ignition, connect a voltmeter to the points of the printed circuit indicated on the figure.

Then turn the trimmer and check the variation of voltage on the instrument. The field of use to pass from a voltage of 0 to 5 Volt is about 4 turns; after 4 turns the screw goes beyond the adjusting band and the values (0V or 5V) do not change even if you keep turning it.

Fuel circuit

The fuel is injected into the intake duct of each cylinder, upstream from the intake valve. This circuit is composed of a pump, a filter, a pressure regulator, a degasser and the electroinjectors.

Electric fuel pump

The electric pump (A) is of the volumetric type with rollers, with the motor immersed in fuel. When the impeller turns, driven by the motor, volumes are generated which move from the intake port to the delivery port. These volumes are marked off by rollers which, during motor rotation, adhere to the external ring. The pump is provided with a no-return valve which is necessary to avoid drainage of the fuel circuit when the pump is not operating. It also has an overpressure valve which short-circuits delivery with intake, when pressures higher than 5 bar occur, thus avoiding overheating of the electric motor.

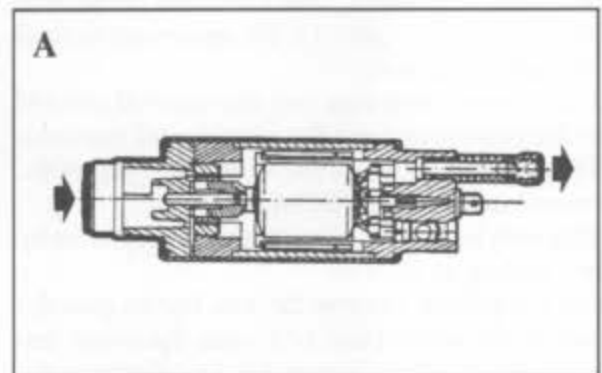

Electroinjector

the injector (A) controls the amount of fuel sent into the motor. The control impulses established by the electronic control unit create a magnetic field which attracts an armature and causes opening of the injector. If the physical characteristics of the fuel (viscosity, density and the injector capacity) and the increase in pressure (pressure regulator) are considered constant, the amount of fuel injected depends only on the opening time of the injector. This time is determined by the control unit according to the conditions of use of the engine, thus dosing the fuel.

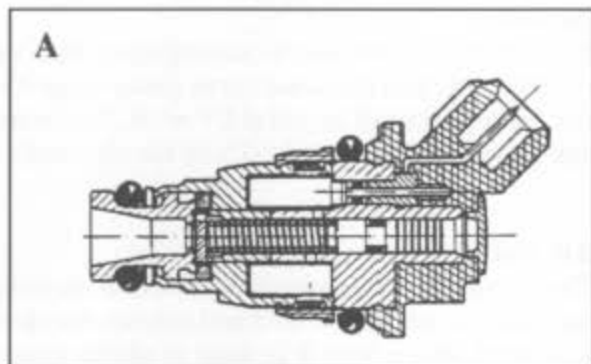

To check good operation of the injector, remove the throttle body, leaving it connected to the system. Making contact with the key and performing the ignition procedure, you should hear the characteristic noise associated with the movement of the armature attracted by the magnet. The fuel output must be regular and the jet must appear well nebulized, without little drops. Avoid leaving the motor at a standstill for long periods with the fuel feed system full. The petrol could clog the injectors, making them unusable. From time to time, after long periods of inactivity, it is advisable to put a special additive in the tank to help clean the critical fuel passages.

Air circuit

The air circuit is composed of an intake manifold, a throttle body and an intake box. This circuit also includes an absolute pressure sensor located at the rear of the filter case together with an air temperature sensor. The throttle position potentiometer is mounted on the throttle shaft of the throttle body.

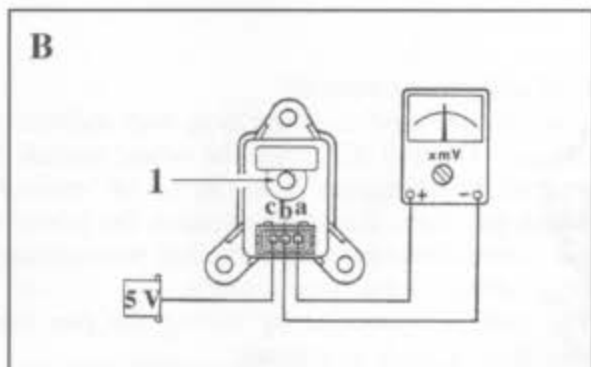

Absolute pressure sensor

This is fed by the electronic control unit and supplies information concerning the absolute pressure of the air inside the filter case. The pressure sensor supplies an absolute air pressure signal to make the correction according to barometric pressure. To test the operation of this component you need a voltmeter (with precision 1 mV) (B). Apply a slight vacuum through the front nozzle (B-1) (sucking it if necessary).

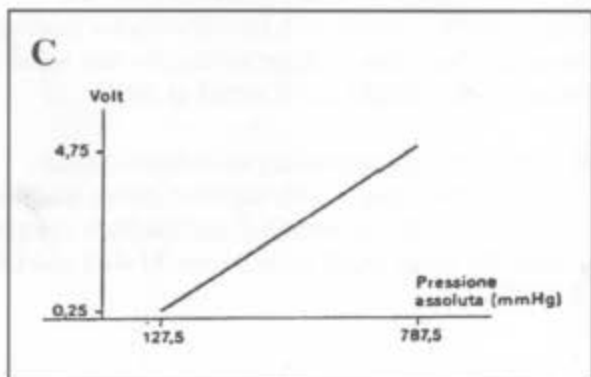

ATTENTION: a high pressure or vacuum could cause breakage of the very fragile ceramic diaphragm of the sensor.

If a variation in pressure is accompanied by a variation in voltage, you can establish that the component is not blocked. The response curve given (page 45 - C) supplies parameters for testing the sensor. During the test the sensor must be fed at 5V +/- 0.25 (electronic control unit). It is possible to measure the output voltage values through pins 11-15 on the electronic control unit.

Air and oil temperature sensor

The sensor (A-1) measures the external air temperature; the electric signal obtained reaches the electronic control unit where it is used to obtain correction according to the air temperature.

The sensor (A-2) measures the engine oil temperature. The electric signal obtained reaches the electronic control unit and is used to make corrections on the basic value. Both are composed of a body that contains a type NTC thermistor (NTC means that the resistance of the thermistor decreases as the temperature increases).

Table (B) gives the temperature values in °C corresponding to a resistance in K. measured on the instrument.

Coil and power module

The ignition used is of the type with inductive discharge. The coil (C-2) and the power module (C-3) receive the command from the I.A.W. control unit which processes the spark advance; the power module also ensures charging of the coil with constant energy, acting on the "dwell" angle.

The coil is controlled by testing the two internal windings. Check as follows:

A - checking the primary resistance circuit.

Check the resistance with the ohm-meter inserted between the two low voltage terminals; the value must be between 0.606Ω and 0.495Ω at 20°C.

B - checking the secondary resistance circuit.

Check the resistance with the ohm-meter inserted between a low voltage terminal and the high voltage terminal; the value must be between 8140Ω and 6660Ω at 20°C.

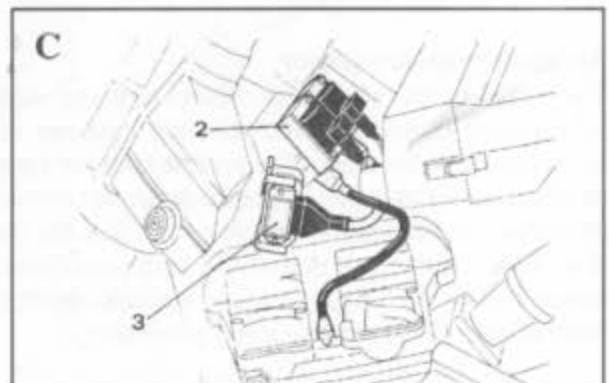
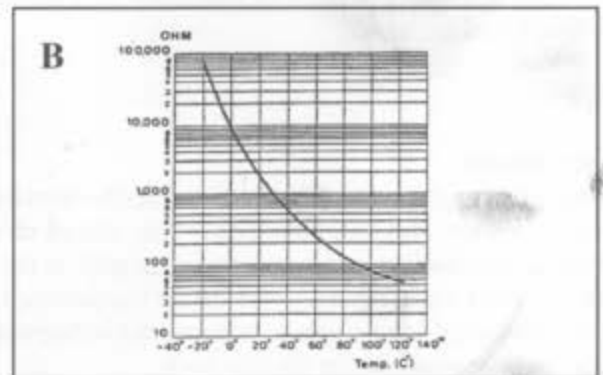
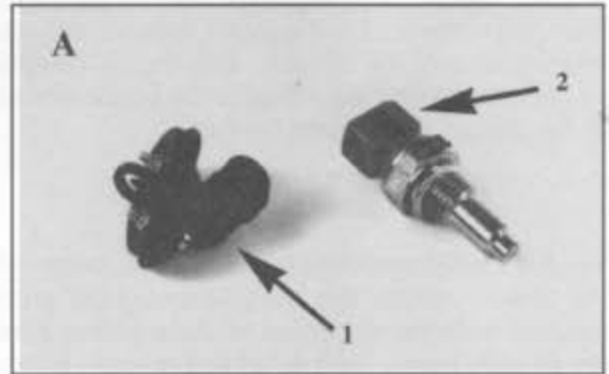

Throttle position potentiometer

The potentiometer (A) is fed by the electronic control unit to which it sends a signal that identifies the throttle position. This information is used by the control unit as the main parameter for defining fuel dosing and spark advance.

Check the signal output on a tester with a scale in Volts, setting the openings in degrees indicated on the scale.

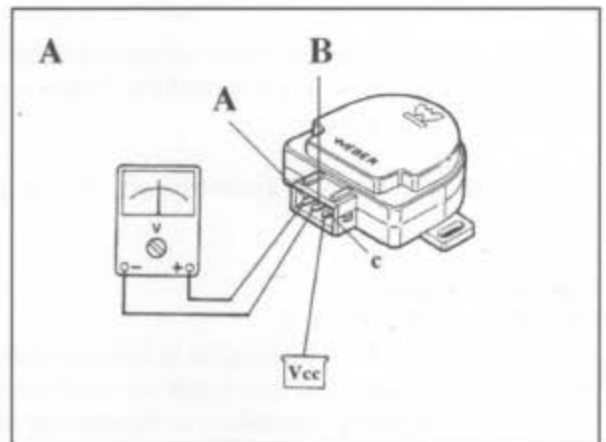

Opening in degrees	0+/-0,25°	25°+/-0,25°	35+/-0,25°	85+/-0,25°
Min. Output voltage in Volts	0,15	2,64	3,31	4,70
Max. Output voltage in Volts	0,25	2,97	3,63	Vcc

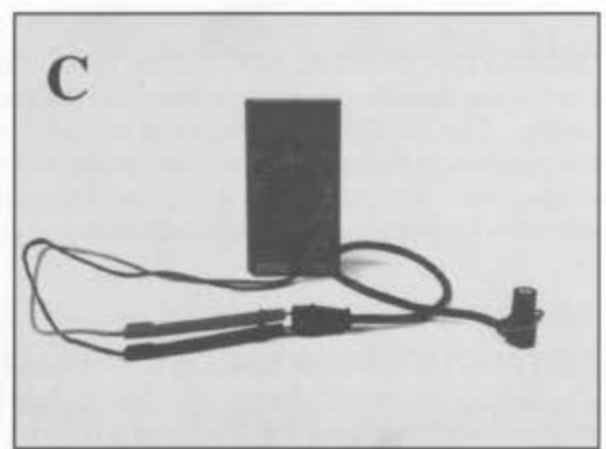
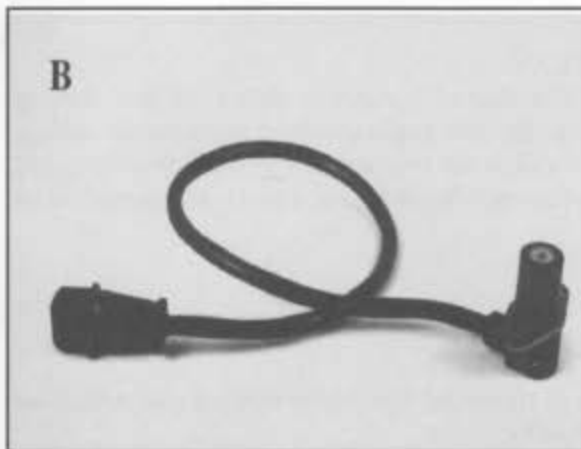

Pick-up

The pick-ups used are of the inductive type. The engine pick-up (D) is located close to the pick-up bush in order to be able to read the 4 pins inserted in the bush.

The cam pick-up (B) is fitted facing the distribution cam in order to be able to read the point of the cam at every turn. The signals received from the pick-ups are used by the control unit to count the number of engine revs and as a basic reference.



To check that the internal circuit of these elements is unbroken, connect a tester to the contacts of the pick-up connector (page 47-C) and read the following value on the instrument on the "Ω" scale:
680Ω +/- 15% at 20°C.

If the value found does not correspond, change the element.

Operation phases

NORMAL OPERATION

In conditions in which the engine is turning over warm at running speed, the I.A.W. control unit calculates the phase, injection time and spark advance exclusively by means of interpolation on the respective maps stored in the memory, according to the number of revs. The amount of fuel thus determined is delivered all at one time to the two cylinders in sequence. The moment of starting delivery is determined, for each cylinder, by means of a map, according to the number of revs.

STARTING PHASE

Whenever the ignition switch is pressed the I.A.W. control unit feeds the fuel pump for a few moments and receives the signals of the throttle opening angle at temperatures relating to the engine.

Proceeding with starting, the control unit receives the engine rev and phase signals which allow it to command injection and ignition. To facilitate starting, as well as the choke for cold starts, the dose is enriched according to the oil temperature.

In motoring over, the spark advance is fixed (0°) until the motor starts. Once it has started, the control unit starts controlling the advance.

OPERATION DURING ACCELERATION / DECELERATION

During acceleration the system increases the amount of fuel distributed in order to obtain the best driving ability. This condition is recognized when the variation of the throttle angle assumes appreciable values, the enrichment factor is proportional to the pressure variation and to the temperature of the lubricating and cooling oil. Similarly, when a negative variation of the throttle opening is found, this is interpreted as an intention to decelerate, so the fuel distribution is reduced.

INSTRUCTIONS FOR USE OF THE DIAGNOSIS INSTRUMENT.

The control instrument for the injection system is connected to the serial line of the control unit and, if an error is found, it allows the display of a code by means of flashing lights.

The code is composed of two separate figures; each figure is composed of an equivalent number of flashes; a more marked pause indicates the interval between two figures.

The synchronism codes indicate the start and end of the error code and are composed of a series of fast flashes.

The transmission of the error codes is cyclical. The acquisition of errors is updated every time the ignition key is turned or the RUN / OFF emergency switch is turned.

The total time for transmitting a code is about 20 seconds.

To check the presence of problems in the electronic injection system, proceed as follows:

- fit the instrument connector into the respective coupling (A) located close to the electronic injection control unit.

Connect the two clamps on the instrument to the battery.

Using the "Test lamp" button, ensure that the check LED lights up.

Check that the ignition key is in ON position and the emergency switch in RUN position.

If the LED flashes it means that there is a problem in the injection system.

The components of the injection system that may be checked with the control instrument are the following:

- air temperature sensor (connector situated at the rear of the filter case);
- oil temperature sensor (connector situated on top of the head at the right side);
- motor revs sensor (situated in the clutch cover at the level of the pick-up bush);
- distribution sensor (situated on the cover of the camshaft);
- throttle opening sensor (situated on the left side of the throttle body);
- absolute pressure sensor (situated on the front of the filter case).

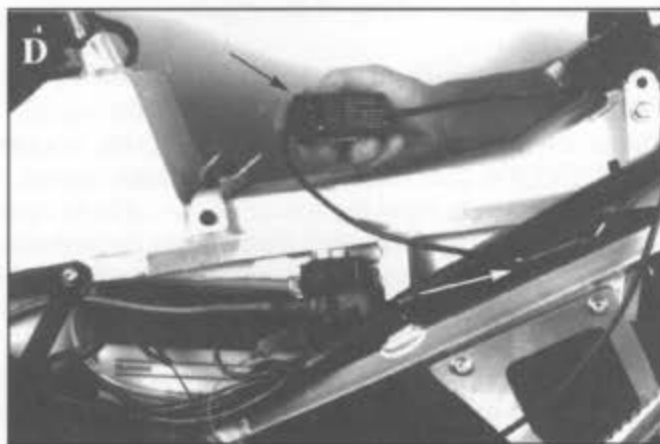

This diagnosis instrument allows the detection of faults due to a short circuit or to an interruption in the circuit. If a sensor blocks while maintaining a fixed output value in V or in W, or maintaining electric continuity, the instrument is not able to detect it.

During operation the injectors on the throttle body and the components for ignition such as the power modules and the coils cannot be detected.

The table below indicates the correspondence between the instrument signals and the respective sensor of the injection system which may present operating problems.

Interpretation of the check lamp signals.

This paragraph illustrates the fault codes that may appear when using the check lamp on the motorcycle. These codes refer to the table given above.

FAULT CODE 1.1: No rev and TDC signal.

The problem may be in the sensor (open circuit), it may be the wiring or the connector (open circuit), or it may be caused by an excessive air gap. When the problem occurs during running and is intermittent, code 1.1 appears together with code 1.3.

Important: In the presence of codes 1.1 and/or 1.3, always check the air gaps (revs and phase).

FAULT CODE 1.2: No phase signal.

Same problems as for **FAULT CODE 1.1**.

FAULT CODE 1.3: Incorrect signals sequence.

Important: In the presence of codes 1.1 and/or 1.2 and/or 1.3, always check the air gaps (revs and phase).

- If it appears together with code 1.1 it may mean there is a problem in the revs signal: revs sensor or cabling broken or short circuiting;
- If it appears together with code 1.2 it may mean there is a problem in the phase signal: phase sensor or cabling broken or short circuiting;
- If it appears without code 1.1 or code 1.2 there may be an incorrect signals sequence due to:

1. incorrect air gaps (revs and phase sensors)
2. irregularities in the sensors air gap due to misalignment or eccentricity of the flywheel distribution gear;
3. accidental stalling of the engine.

Important: the fault code 1.3 may be detected by the control unit only when the engine is turning over.

FAULT CODE 2.1: Incorrect air temperature signal.

The problem may be in the sensor or the cable or connector may be broken or short circuiting.

FAULT CODE 2.3: Incorrect oil temperature signal.

The problem may be in the sensor or the cable or connector may be broken or short circuiting.

FAULT CODE 3.2: Incorrect signal from the pressure sensor.

The problem may be caused by malfunction of the pressure sensor or by a damaged wiring or connector.

N.B.: Ensure that the sensor is of the type suitable for the motorcycle by checking the code on the spare parts catalogue.

FAULT CODE 3.3: Incorrect signal from the throttle potentiometer.

The problem may be caused by malfunction of the potentiometer or by a damaged wiring or connector.

Error code	Line
1 - 1	Motor revs sensor
1 - 2	Distribution sensor
1 - 3	Sequence
2 - 1	Air temperature sensor
2 - 3	Oil temperature sensor
3 - 2	Absolute pressure sensor
3 - 3	Throttle sensor

Ecu connector position

1 - black	19 - black
2 -	20 -
3 - viole	21 -
4 - yellow-blue	22 -
5 - grey-black	23 - orange
6 -	24 - dark blue-red
7 -	25 - red
8 - blue	26 - light blue - white
9 -	27 - white
10 - yellow-red	28 - white
11 - red-green	29 - red-black
12 - light blue	30 - orange-black
13 -	31 - green
14 -	32 -
15 - yellow-black	33 - white-black
16 -	34 -
17 - grey-yellow	35 - yellow-green
18 -	

Key to the electronic injection system diagram

- 29) Coupling connector
- 30) Battery connection
- 31) Microprocessor control unit
- 32)
- 33) Injectors and ECU control relay
- 34) Fuel pump control relay
- 35) Side stand protection relay
- 36) Connector for IAW system diagnosis
- 37) Throttle potentiometer
- 38) Oil temperature sensor
- 39) Engine shaft position sensor
- 40) Engine revs sensor
- 41) Air temperature sensor
- 42) Injectors
- 43) Absolute pressure sensor
- 44) Injectors
- 45) Electronic ignition module cylinder 2
- 46) Electronic ignition module cylinder 1
- 47) Ignition coil cylinder 1
- 48) Ignition coil cylinder 2

Cable colour code

Bk	black	Bn	brown
G	green	Lb	light blue
R	red	B	dark blue
V	violet	O	orange
W	white	Y-R	yellow-red
R-G	red-green	Y-B	kyellow-black
Gr-Y	grey-yellow	B-R	blue-red
Lb-W	light blue-white	R-B	red-black
O-B	korange-black	W-B	kwhite-black
Y-G	yellow-green		

DIAGRAM FOR DISMANTLING THE ENGINE FROM THE FRAME

Diagram for dismantling the engine from the frame	E.54
Dismantling the bodywork	E.55
Dismantling the saddle and tail	E.55
Dismantling the filter cover	E.55
Dismantling the fairing	E.55
Dismantling the engine from the frame	E.56
Dismantling the throttle group and the filter case	E.56
Dismantling the exhaust system	E.56
Dismantling the clutch connection	E.57
Dismantling the electric connections	E.57
Secondary chain	E.57
Engine anchoring bolts	E.57
Radiators	E.57
Dismantling the engine from the frame	E.57

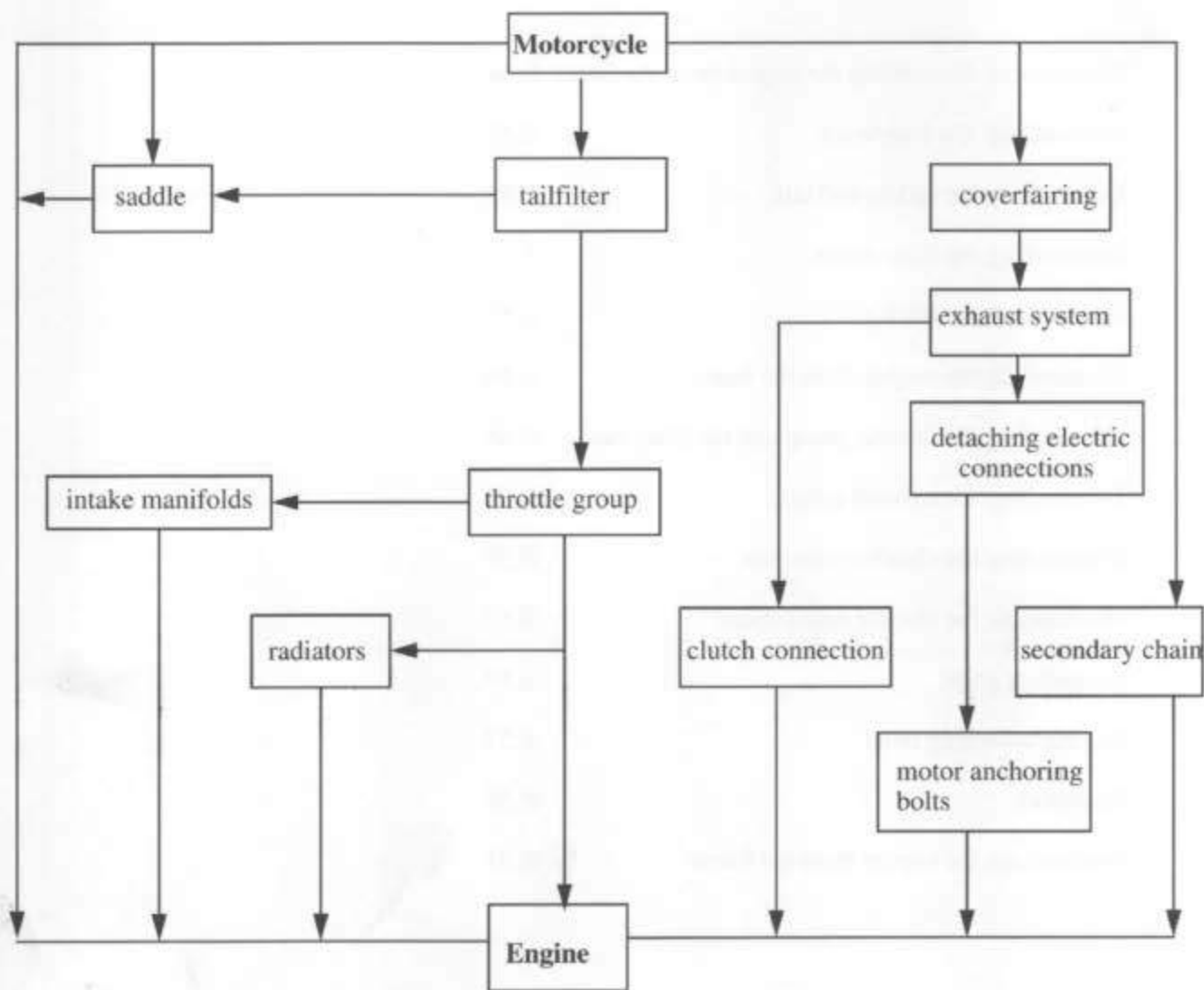

Diagram for dismantling the engine from the frame

Follow this sequence of operations to remove the engine from the frame. Before working on the motorcycle, it is good practice to clean it well externally.

After cleaning the bodywork parts (fairing, tail, etc.), dismantle it and carefully clean all the cycle parts and the engine.

ATTENTION: If cleaning with a jet of water under pressure, be very careful not to point the jet at lubricated parts such as wheel bearings, fork pin, steering column caps, etc.

Do not spray with the jet near painted part or self-adhesive labels such as the approval plate or indications for maintenance.

Be very careful too with the electric connections and the sensors of the electronic injection system, as well as with the coils and the ignition bimodule.

DISMANTLING THE BODYWORK

Dismantling the saddle and tail

- Lift the pillion and unscrew the knob (A-1) that holds down the rider's saddle and proceed to dismantle the latter;
- after having unscrewed the fuel filling cap, remove the catch tray (A-2);
- unscrew the three screws that anchor the sundries box (A-3) and remove the box;
- remove the four side screws (A-4) that secure the tail to the saddle support frame and dismantle it with due care.

Dismantling the filter cover

To dismantle the air filter cover, just remove the front retaining screw (A-5) and the rear one (A-6), then proceed to remove it.

Dismantling the fairing

- First of all remove the two rear-view mirrors (B), unscrewing the retaining screws; be careful with the two spacers fitted between the fairing support and the fairing itself;
- remove the two side panels, slackening the three screws (C) at the side and the four central joining screws, and also unscrewing the rear support screw fixed to the silent-block connected to the exhaust compensator;
- slip the two air intake sleeves off the filter case (D);
- after having removed the two side panels, dismantle the dome, slipping it out at the front.

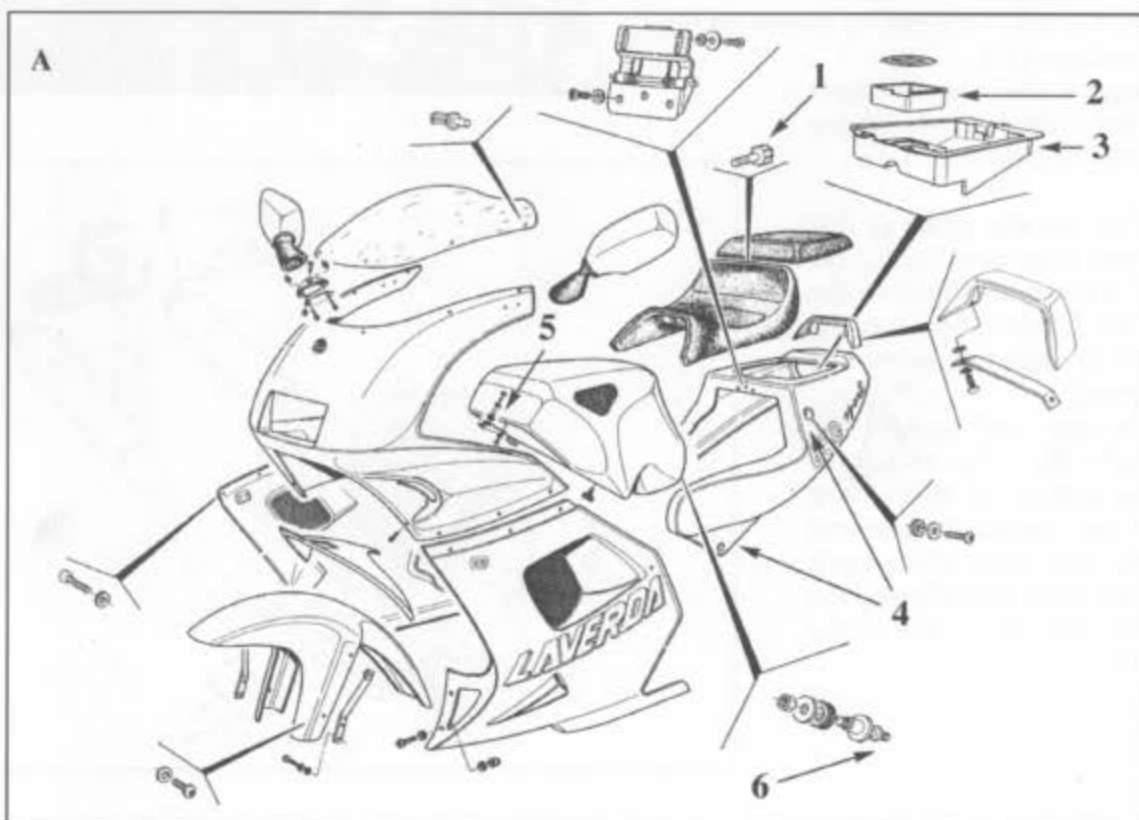
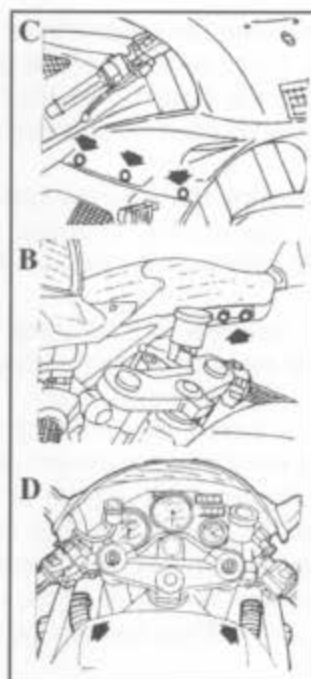

Dismantling the engine from the frame

At this point, to continue the operations of dismantling the engine from the frame, all the engine utilities must be disconnected.

Dismantling the exhaust system

- Slacken the retaining clamps between the silencers and the exhaust compensator (C-1);
- unscrew the retaining screws between the side supports and the silencer (C-2);
- slip out the silencers;
- unscrew the retaining clamps connecting the front pipes to the exhaust conveyer, unscrew the retaining screws of the exhaust ring nuts on the head (C-3), then slip out the pipes, if necessary tapping lightly with a rubber hammer, against the inside of the curves of the exhaust pipes. Then remove the compensator (C-4).

Detaching the throttle unit

To detach the engine from the frame it is not necessary to disconnect all the components of the unit. The throttle unit must be dismantled only in the event of its being replaced or repaired. To remove the engine from the frame, proceed as follows:

- slacken the two retaining clamps on the intake manifolds (A);
- remove the two air input pipes to the filter case, slackening the two retaining clamps (A-1).

Note: if the throttle group is dismantled only to remove the engine, it is not necessary to dismantle the gas and air transmission and the sensors of the injection system on the filter case;

- Unscrew and remove the two top bolts (B-1) that anchor the rear frame section and, after having removed the silencers (previous operation), turn them downwards (B-2), at the same time slipping the two rubber sleeves off the intake manifolds.

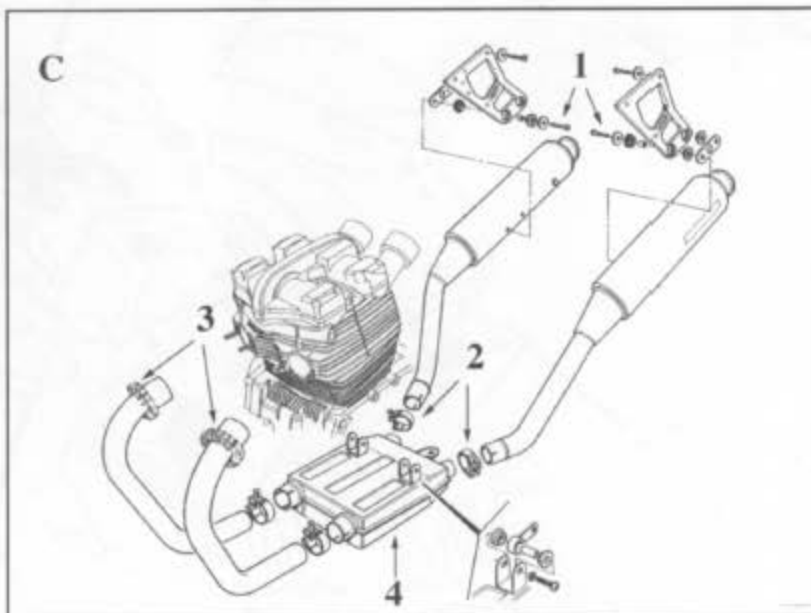
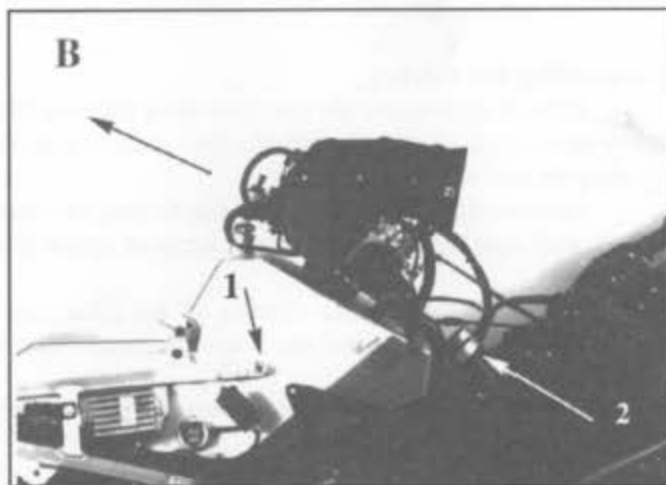
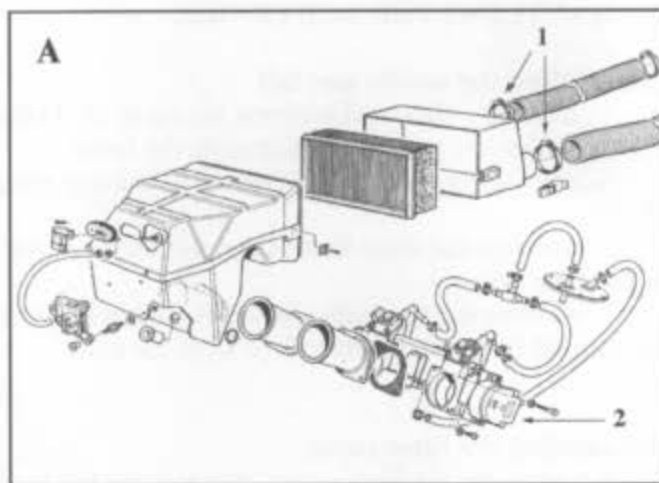

Dismantling the clutch connection.

To dismantle the connection of the hydraulic transmission to the engine, it is necessary to remove the side casing of the hydraulic clutch and the engine pinion (A) by unscrewing the three retaining screws. To remove the casing easily, screw a 6 mm screw into the centre (A-1), securing it in such a way that it can be used as an extractor; then carefully extract the casing, tapping it lightly with a plastic hammer. Leave the hydraulic oil pipe connected to the casing (A-2).



Detaching the electric connections.

Disconnect all the electric wiring from the engine, starting with the battery connection cable, then the spark plug cables, the connections of the oil temperature sensor (on the left side of the head), the thermal probe (on the radiator oil connection), the PK sensor, the phase sensor (on the tappets cover), then disconnect the connection of the alternator, the cables of the starting motor and the engine breather pipe. Finally plug the intake manifolds with a rag.

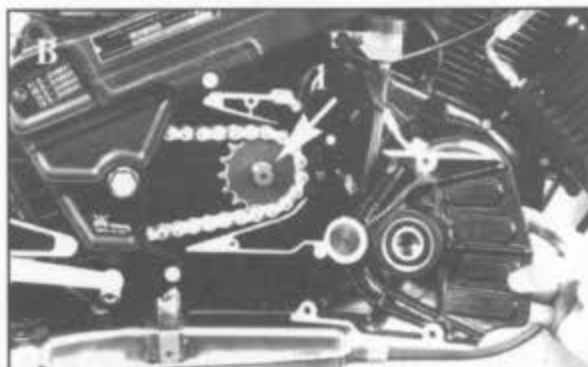

Secondary chain. Engine retaining bolts.

Slacken the wheel retaining nuts, the chain adjusting screws and, after having completely slackened the chain, remove the sealing seeger ring and the chain pinion with the chain itself (B-1). Place a hydraulic jack under the engine to allow you to remove the engine more easily (B-2).

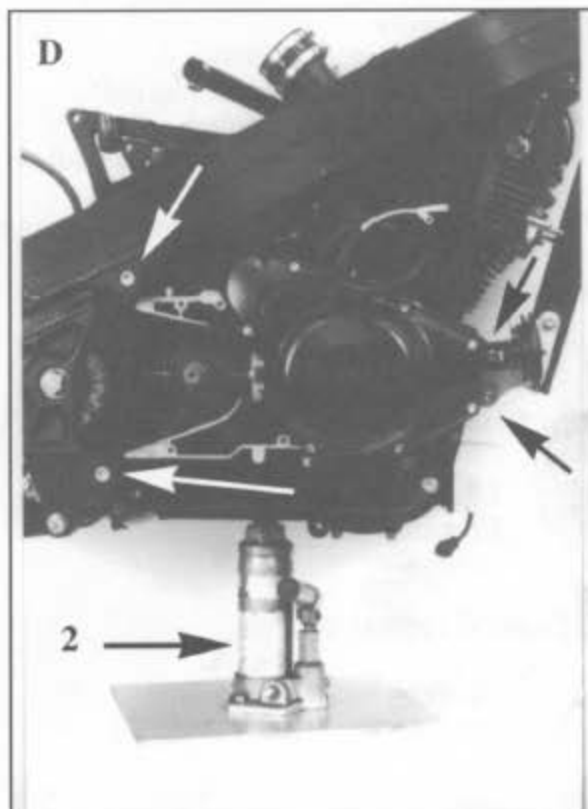

Radiators.

Dismantle the radiators, disconnecting all the pipes joining them to the engine.

Dismantling the engine from the frame

After having carefully performed the operations described above, unscrew the bolts on the front plates, then unscrew the four retaining bolts at the rear of the engine and dismantle the engine, slipping it out at the bottom (D).

Place the engine on a suitable support.

DISMANTLING AND OVERHAULING THE ENGINE

Diagram of the sequence for dismantling the engine	F.60
Brief dismantling sequence	F.61

OVERHAULING THE ENGINE BY GROUPS F.62

Overhauling the head	F.62
Head clearance	F.63
Camshafts	F.63
Tappets	F.64
Valves - seats - valve guide	F.64
Checking valve seal	F.64

HEAD ASSEMBLY F.66

CYLINDERS AND PISTONS F.68

Dismantling	F.68
Cylinders	F.68
Pistons	F.69
Assembly	F.69

ENGINE SHAFT AND CONNECTING RODS F.71

Dismantling	F.71
Assembly	F.71
Checking shaft centering	F.72
Small end of the connecting rod	F.73
Big end of the connecting rod	F.73
Warnings for fitting the engine shaft on the bottom casing	F.73
Fitting the shaft of the counter-rotating masses	F.74

LUBRICATION AND COOLING SYSTEM F.74

Operation	F.74
-----------	------

OIL PUMP F.76

Dismantling	F.76
Checking	F.77
Assembly	F.77

STARTING FREE WHEEL F.77

Dismantling	F.77
Checking	F.77

PRIMARY TRANSMISSION AND CLUTCH F.78

Dismantling F.78

List of possible causes of clutch malfunction F.80

Primary transmission pinion F.80

Clutch control rod F.81

Clearance between clutch bellhousing and drive plate F.81

Clutch plates F.81

Clutch springs F.81

Clutch transmission F.82

Assembly F.82

GEARBOX F.83

Dismantling and reassembly of the chain pinion F.83

Dismantling the gearbox F.83

Checking F.84

GEAR LEVER F.87

Dismantling F.87

Assembly F.87

Selector regulation F.88

Diagram of the sequence for dismantling the engine

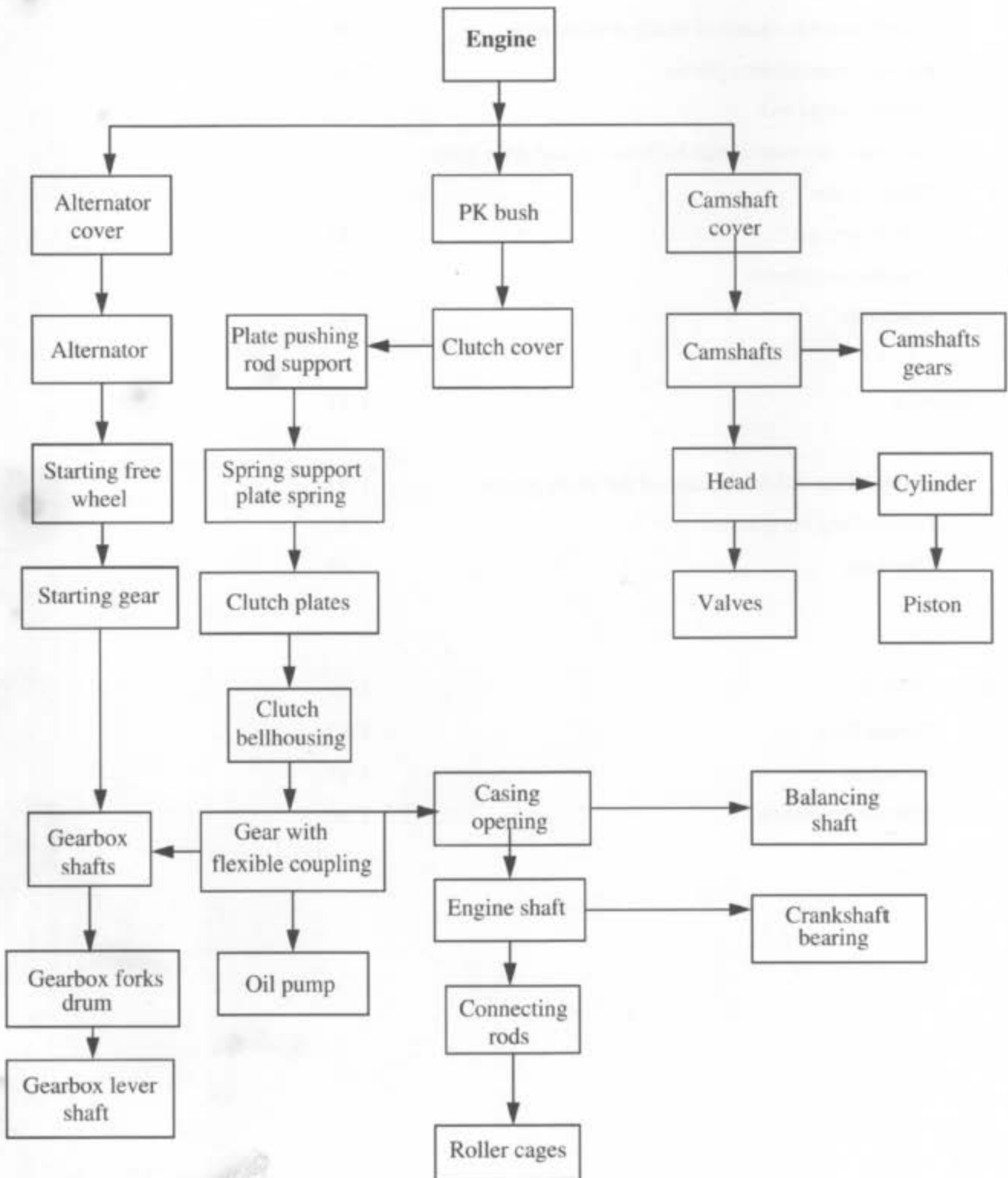

The engine may also be dismantled following a faster procedure which allows all the engine groups to be kept assembled, working only on the groups to be overhauled.

Brief dismantling sequence

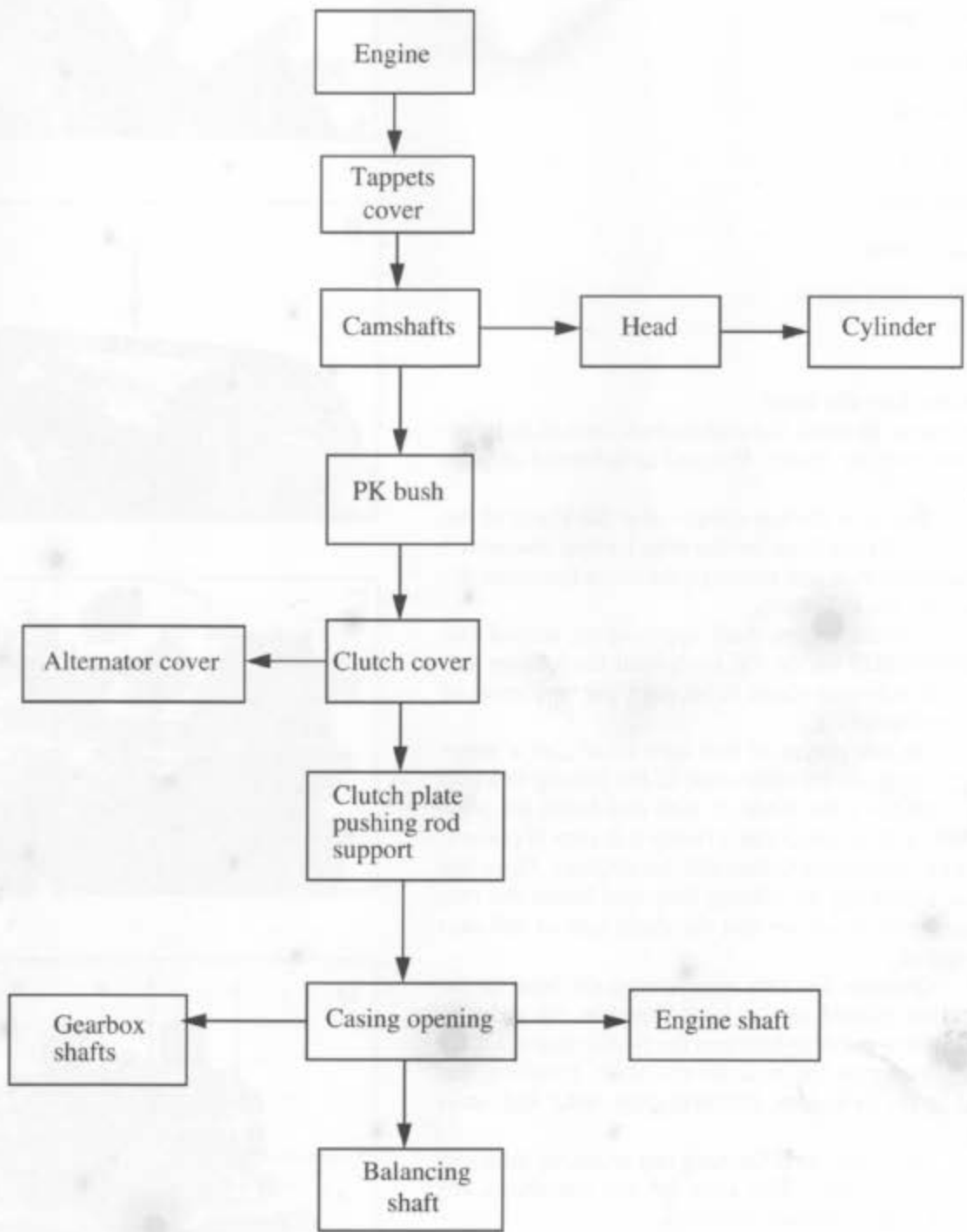

OVERHAULING THE ENGINE BY GROUPS

- 1 - Head
- 2 - Cylinders and pistons
- 3 - Linkages
- 4 - Lubrication
- 5 - Starting
- 6 - Clutch
- 7 - Gearbox
- 8 - Gear lever
- 9 - Secondary chain

Overhauling the head

To remove the head, the engine must first of all be removed from the frame. Proceed as indicated on page 56.

- Remove the top cover - slip the blade of the tensioner (A) out from the top after having unscrewed the retaining bolt and removed the chain tensioner device from the cylinders,

- turn the engine shaft, applying the special tool **061008000020** on the PK bush until the joining link in the distribution chain is between the two gears of the camshafts (B);

- tie two pieces of thin wire about half a metre long to the links on either side of the joining link;

- remove the piece of wire that holds the joining link with pliers or cut it (wrap it in rags to prevent pieces of wire from falling into the engine). Open the chain, removing the joining link, and fasten the two wires to the casing so that the chain cannot fall into the engine;

- unscrew the two nuts joining the head to the cylinders, placed at the front between the exhaust pipes and at the rear between the intake pipes (C);

- unscrew the nuts on the studs fastening the head to the cylinders, following the order indicated (D);

- unscrew the remaining cap retaining nuts and remove the caps. The caps for the camshafts are marked with reference numbers.

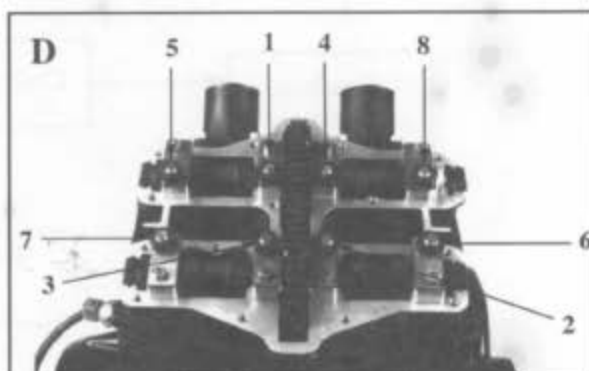
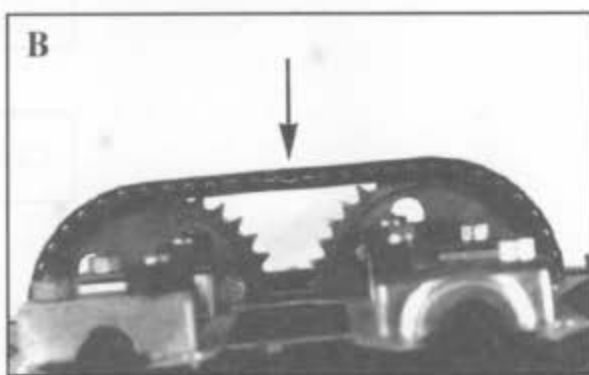

- using a magnet or long-nose pliers, remove the tappets and the calibrated shims placed on top of the valves. Both the tappets and the shims must absolutely not be mixed up with one another (A).

- To remove the valves you must:

- a) place the head on the work bench;

- b) compress the springs with the special tool **061008V18905** (to prevent the valve from going down during this operation, place a suitably sized block of wood on the bench inside the combustion chamber) (B);

- remove the cotters with tweezers, keeping all the parts distinct. Valves, cotters, washers and springs must be reassembled in their original positions without exchanging them;

- remove the rubber seals on the valve guides with pliers only when they have to be changed.

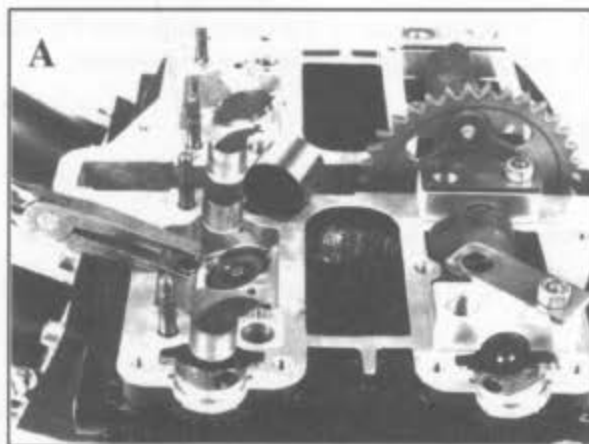

CHECKING AND SPECIAL OPERATIONS

Head clearance

With a centesimal precision rule and a feeler gauge, check the evenness of the head clearance, placing the rule as indicated by the 8 lines (C): the error is given by the thickness of the blade of the feeler gauge that passes exactly and with slight friction under the rule. The maximum admissible error is 0.05 mm.

If the error is higher than the allowed value, rectify the surface by removing the smallest possible amount of material.

Camshafts

There must be no visible sign of wear, ridges, scratches or chips on the active surfaces of the cams or on the rolling tracks.

The profile of the teeth of the two gears must never appear worn (see maintenance of the distribution chain).

The maximum admissible clearance for the camshaft supports is 0.10 mm for the side supports and 0.12 for the sides, measured by inserting the blade of a feeler gauge between the shaft and the support (A).

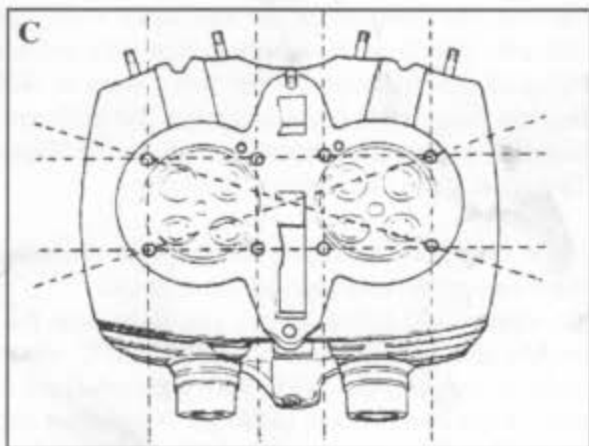
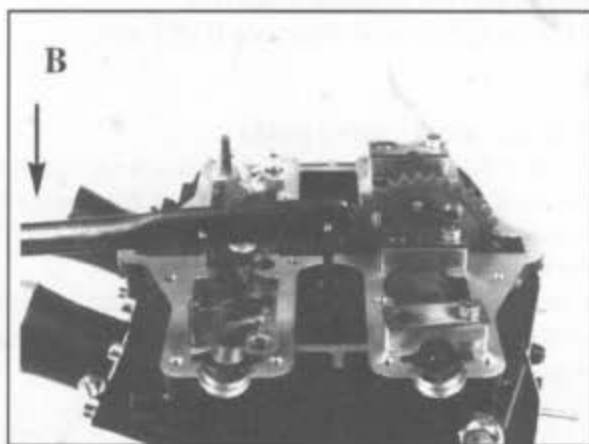

To check the wear of the cams, measure the distance **A** indicated in figure **B** with a micrometer.

exhaust 'A' when new	33.5 mm
intake 'A' when new	34 mm
exhaust 'A' at limit of wear	33.4 mm
intake 'A' at limit of wear	33.9 mm

Tappets

These must be whole and without traces of wear; using a micrometer gauge and a bore gauge, check the clearance between the tappet and the head housing (if these two instruments are not available, use a feeler gauge, inserting the blades in the space between the tappet and the housing wall) (**C**).

Maximum allowed clearance 0.055 mm.

Valves - seats - valve guide

Each valve must be cleaned with a wire brush to remove scale and examined to check for cracks in the mushroom area, traces of wear on the stem and ridges on the area that rests on the seat.

Check that the head is not cracked in the combustion chamber, especially in the area between the valve seats.

Using V blocks and a comparator, check eccentricity of the valve during rotation (**D**).

The maximum admissible eccentricity of the stem is 0.05 mm.

Measure the diameter of the hole in the valve guide in different points using a bore gauge with expandable ball and the diameter of the valve stem at different heights using a micrometer gauge: the difference between the two measurements gives the clearance. The admissible clearance is 0.20 mm.

If the clearance is larger, change both the valve and the valve guide and regrind the seat too.

To remove old valve guides you must heat the head evenly to a temperature of 210° - 220°C, then eject them by tapping the guide with a punch from the inside of the combustion chamber (all carbon deposits must have been removed from the part of the valve guide that projects into the ducts).

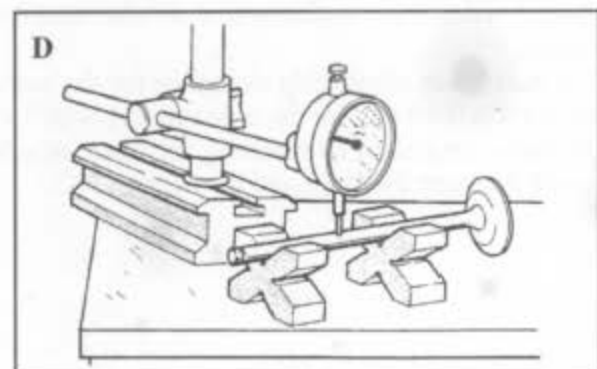
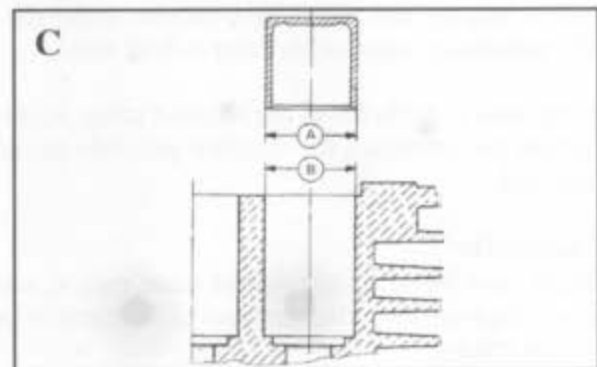
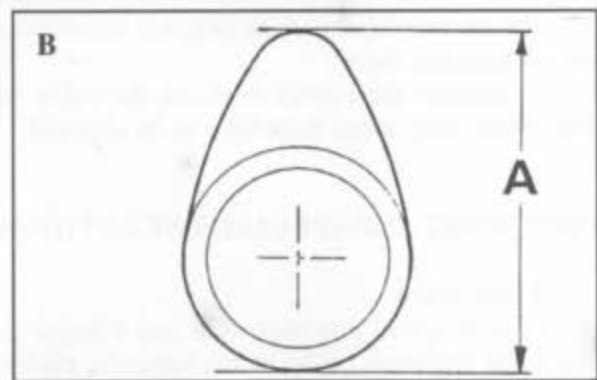
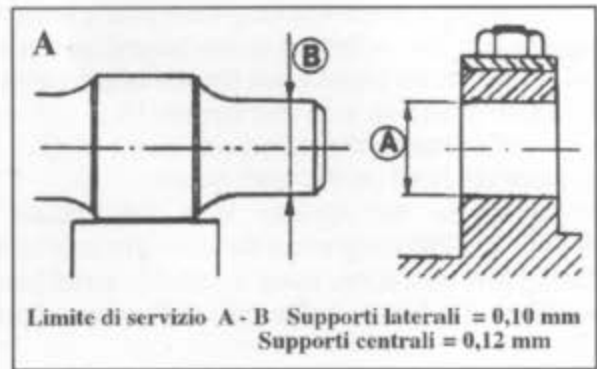

Also when inserting new valve guides the head must be heated to a temperature of 210° - 220°C.

The interference when cold between the valve guides and the hole in the head is 0.075 mm +/- 0.105.

After planting the internal hole in the valve guides must be bored so that the diameter is the same as indicated in fig. A.

It is indispensable to grind the valve seats with a special grinder equipped with a pilot and other equipment in the following specific cases:

If the contact area is lightly embedded, grind to eliminate the ridge, then connect with the inclinations indicated in fig. B.

The length of these inclined connections influences the width of the valve contact area in the seat which must be 1/1.2 mm for intake and 1/ 1.2 mm for exhaust.

The actual contact area may be made visible by colouring the seat with dissolved aniline dye and turning the valve on it.

The valves too may be ground on the contact strip of the mushroom; the minimum thickness of the mushroom edge after grinding must be 0.5 mm for intake and 0.5 mm for exhaust .

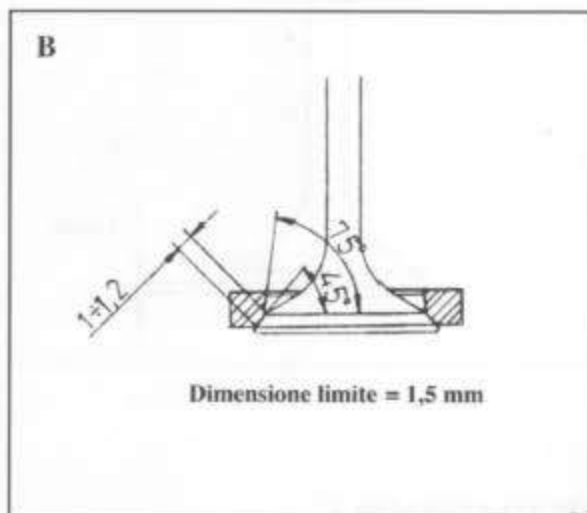
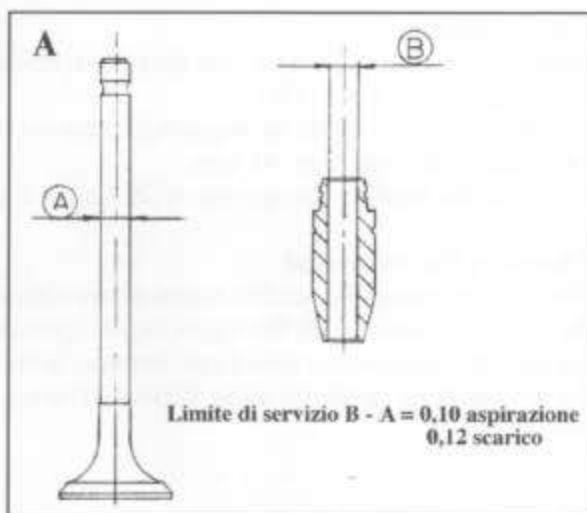

Valve springs

Inspect the valves, ensuring that they have no flaws and that the bases are sitting square: the maximum allowed offset is 1.5 mm (B).

Measure the free length: at origin 42.5 mm +/- 0.4

- minimum allowed size: 41 mm.

At origin the load on the springs is 29 kg +/- 1 at 33.5 mm.

Checking the valve seal

When dismantling the head to remove deposits or when grinding the valves, the seal must be checked before the final assembly: with the valve closed (pressed against the seat of the spring or with one finger on the mushroom), pour some petrol into the duct and observe the seepage between the mushroom and the seat: if the job has been perfectly done, there will be no seepage; however, the presence of slight seepage is acceptable.

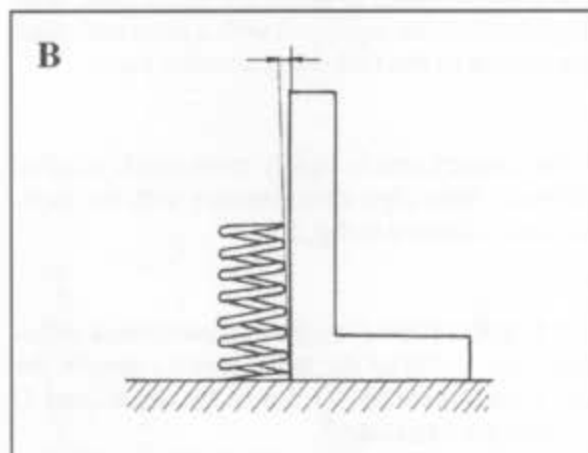
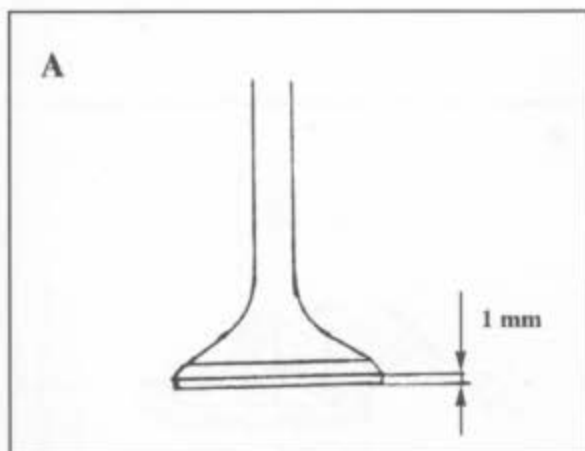
**HEAD ASSEMBLY**

Assemble in reverse order to disassembly; for parts other than the head, if necessary, follow the instructions in the chapters that deal specifically with them.

- Before assembly, remove carbon deposits from the combustion chamber using a smooth-edged scraper or a wire brush; be careful not to score the aluminium on the head, especially on the lower clearance;
- the head gasket must be replaced whenever disassembled, as well as the cylinder seal ring which is an integral part of the head gasket;
- the valves, springs, shims and cotters must be fitted using the same tools and procedures as for disassembly.

To fit the rubber seals on the valve guides (A), use the special tool **061008V20903**; ensure that each part returns to its original place.

- When fitting the head onto the cylinders, the two ends of the chain taut (B). Take the same precaution whenever turning the engine shaft with the chain open;

- tighten the nuts on the heat anchoring studs with a torque wrench following the order indicated at 1.5 Kgm, then again at 3 Kgm to reach a final torque value of 4.5 Kgm. It is also advisable to go over them several times (C). Lastly tighten the two nuts at front and rear of the cylinder head coupling;

- check that the camshafts, fitted with the nuts fastened but without the distribution chain, can turn without irregular friction;

- check the valve clearance again and re-adjust if necessary;

- put into distribution phase, fitting the chain and adjusting the tension, after having fitted the blade and the chain tensioner (D);

- before putting the cover on the head, **oil all the moving parts.**

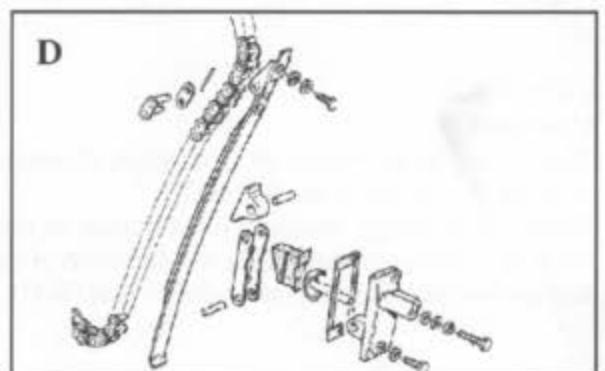
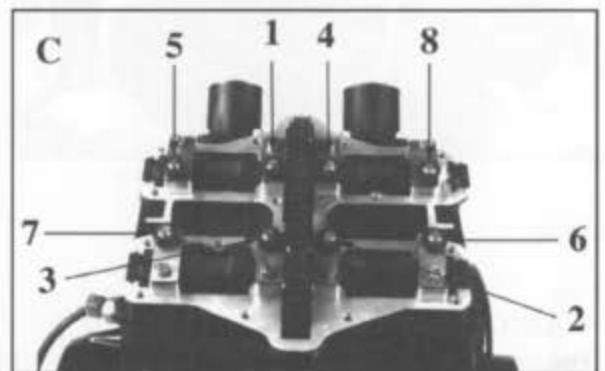
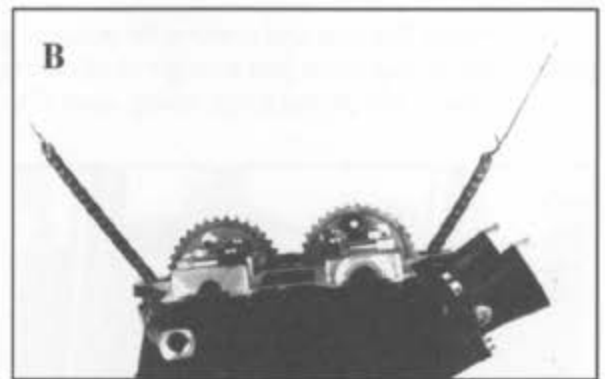
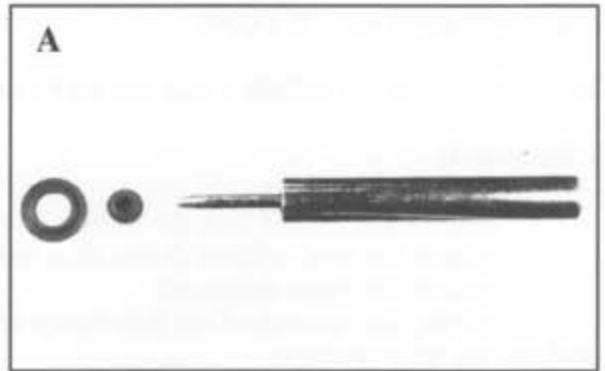

WARNING:

If the head has to be completely replaced, remember that **the head complete with camshaft supports is supplied as a spare part.**

Do not fit other supports or the ones of the head being replaced.

CYLINDERS AND PISTONS

Before removing the cylinders and pistons the engine must be removed from the frame.

Disassembly.

- Remove the engine from the frame;
- remove the head without dismantling the camshafts;
- remove the chain tensioner;
- holding the two ends of the distribution chain taut with the wires, remove the vibration-damping pad and slip out the cylinders;
- using a pointed tool, remove the circlips from the pin (A). Ensure that the circlips do not fall inside the engine;
- extract the pins and remove the pistons: generally it is not advisable to extract the gudgeon pin completely, but to slip it out just enough to allow removal of the piston;
- remove the piston rings, being careful to open them just enough to allow removal.

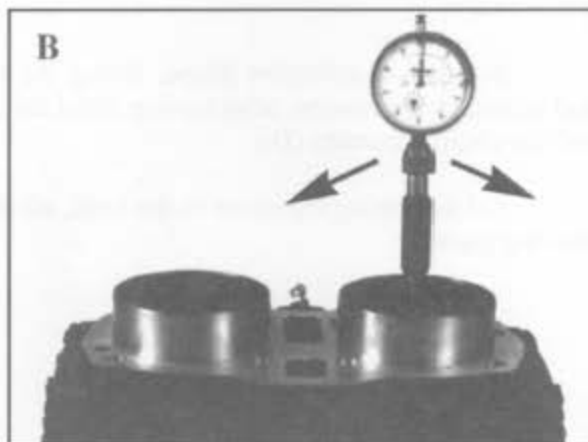

WARNING

The pistons, piston rings and pins must be marked so that they can be recoupled and replaced in the original position.

CHECKING

Cylinders

There must be no ridges or clear signs of seizing or wear on the inside of the barrel.

Using a bore gauge, measure the diameter of the barrel at three different heights in the direction of the pin and in the direction perpendicular to that (B-C).

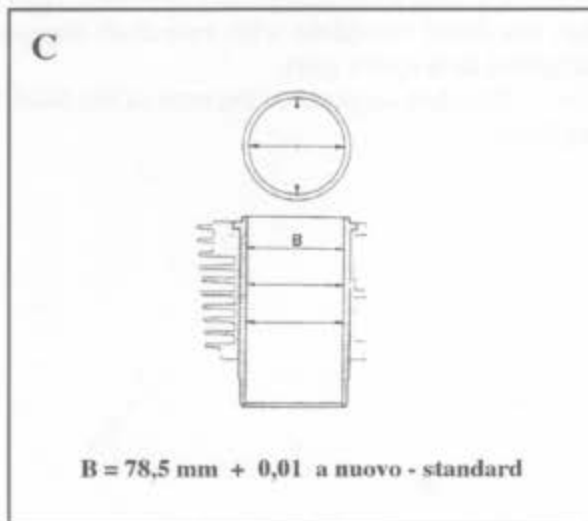

If the barrel is outside the wear limits, it must be re-bored and smoothed and larger pistons must be fitted. The standard piston diameter is 78.5 mm, while an enlarged piston of 78.8 mm may be fitted.

To change the barrels, heat the entire cylinder block in an oven to a temperature of 210° - 220°C, then slip out the barrels and fit the new ones while the cylinder block is still warm.

The maximum allowed ovality of the barrel is 0.05 mm.

The maximum allowed taper of the barrel is 0.05 mm.

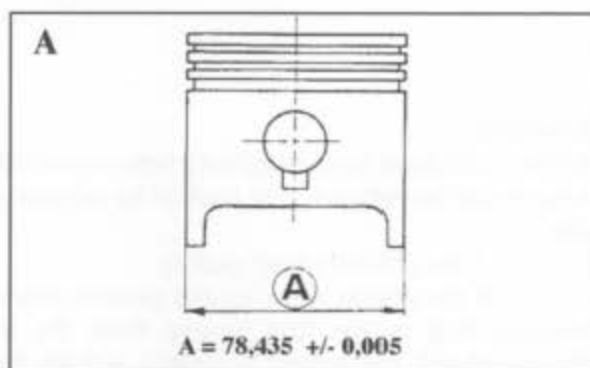

Pistons

Check visually to ensure there are no signs of scoring, seizing, wear, overheating or cracks, especially in the area of the pin stubs.

Measure the piston diameter with a micrometer gauge at the base of the skirt in the direction perpendicular to the pin.

The normal clearance between piston and cylinder is mm 0,060/0,070. (A)

The maximum allowed clearance between piston and cylinder is 0.140 mm (A).

The diameter of the hole for the gudgeon pin is:

18 mm +/- 0.004-0.00€
at service limit: **18.05 mm.**

The piston rings must be whole, without chips, scores or ridges.

Check the clearance between the piston ring and the groove on the piston (B); at wear limit the maximum clearance is 0.15 mm.

Place the piston ring so that it is sitting square in the barrel at different heights:

The clearance at the ends, measured with a feeler gauge (C), must be:

when fitted new: 0.25 / 0.40 mm
at wear limit: 0.80 mm.

Check that the elements of the chain tensioner (especially the rubber parts) and of the vibration-damping pad are entire and free from wear (D).



Assembly

All the parts must be cleaned well before assembly; it is important to put each part back in its original position.

- Fit the cylinder base gasket;
- fit the piston rings on the pistons: the compression ring in the first groove from the top is chrome-plated, the second is normal and the third is an oil scraper ring. The cuts in the rings must be offset, for example at an angle of 120° to one another (A). The word "TOP" on the ring must be facing upwards (B);

- insert the pins in the pistons. The arrow on the top of the piston must be facing forward, in the direction of driving the motorcycle.

The small end of the connecting rod must be lubricated before fitting the piston;

- the circlips on the pin must be changed each time it is disassembled. It is important for the circlip to fit firmly into the groove on the piston, which must be clean;

- to fit the cylinders easily on the pistons, apply the two special piston ring clamping tools **061008000021**. Turn the engine shaft holding the distribution chain taut, so that the pistons are at the same height (C).

Lubricate the inside of the barrels, the piston skirt and the piston rings generously with oil before assembling the cylinder.

As soon as the pistons have been sufficiently inserted, remove the piston ring clamps, insert the vibration-damping pad (D) and pass the ends of the chain through the passages between the cylinders;

- complete fitting the cylinder;
- fit the chain tensioner;
- fit the head after changing the gasket;
- adjust the distribution chain.

ATTENTION: When the head has been removed, the valve clearance must always be checked on reassembly.

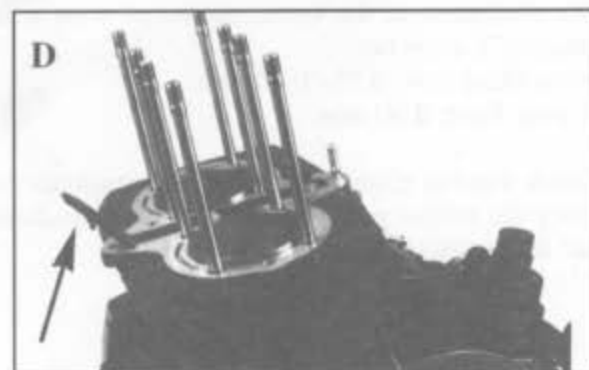
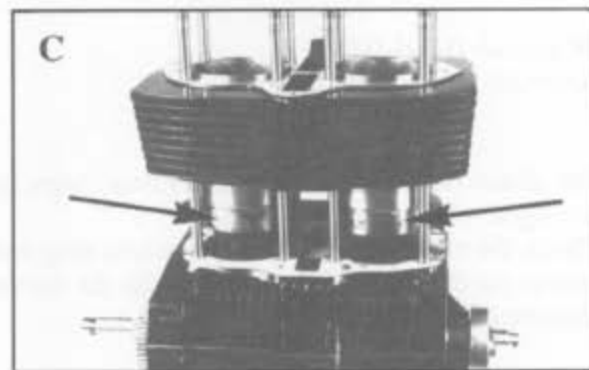
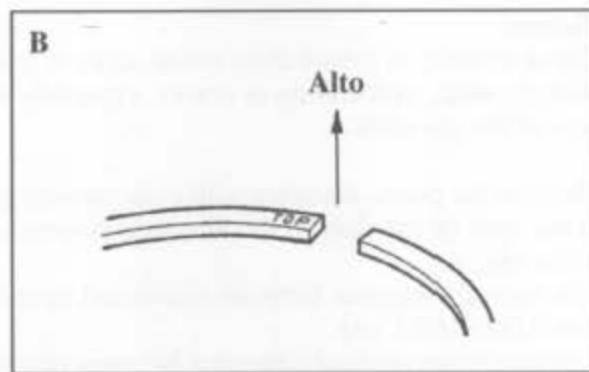
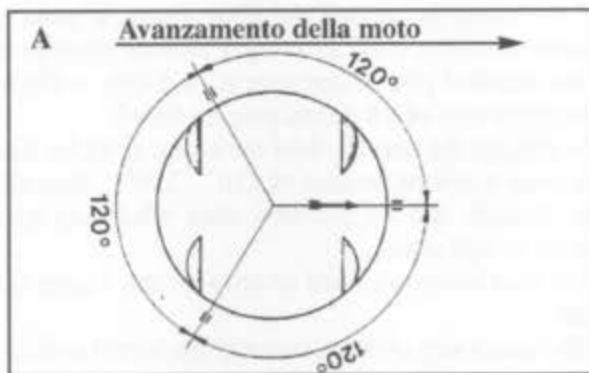

ENGINE SHAFT AND CONNECTING RODS

The engine shaft is of the composite type with crank pins at 180°. It turns on two external ball bearings and two internal roller cages. The connecting rods, all in one piece, work on the head on roller cages.

Disassembly

Remove the engine from the frame.

- Proceed as indicated on page 61 (brief engine dismantling sequence).

These operations are necessary for overhauling and dismantling the engine shaft in order to change the cages, bearings and connecting rods.

Once the casing has been opened, the complete engine shaft can be removed from the lower casing:

- remove the alternator group (A-1), the starting free wheel (A-2), the free wheel gear (A-3), the spacer with roller cage (A-4) and the countershaft gear (A-5);

- remove the pump control pinion (B-1), the primary transmission pinion (B-2) and the two side crankshaft bearings (B-3 and B-4);

- place the engine shaft on the template and apply a press on the big end pin (C-1), in this way the shaft is dismantled and the connecting rods and roller cages can be changed;

- to change the roller cages on the central supports, position the central group on the template, apply the press on the pin (C-2) and dismantle the central flywheel, turn the shaft through 180° and dismantle the other flywheel. At this point the roller cages on the central crankshaft supports can be changed (C-3).

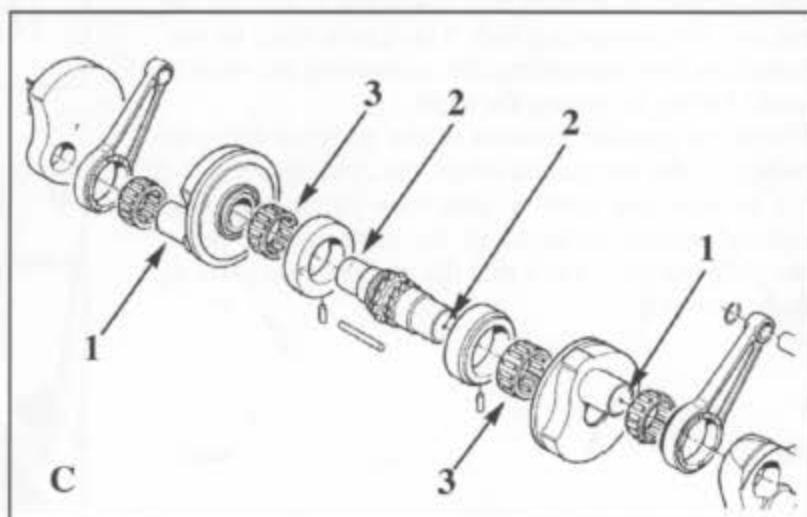
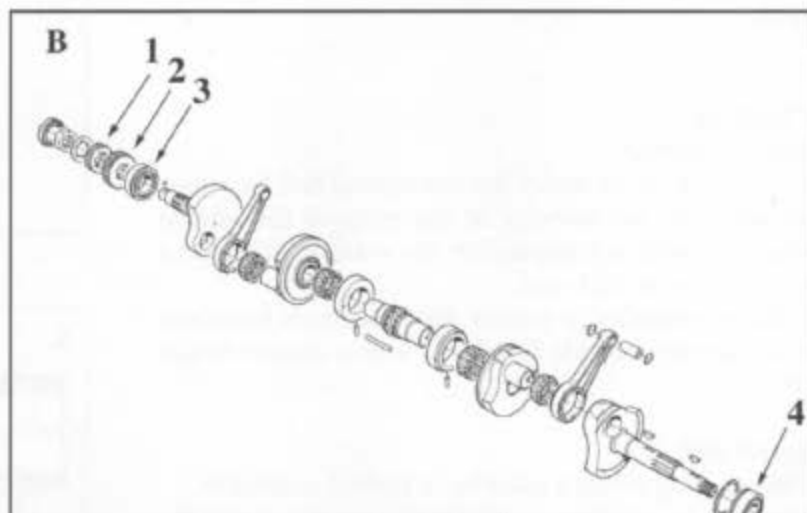
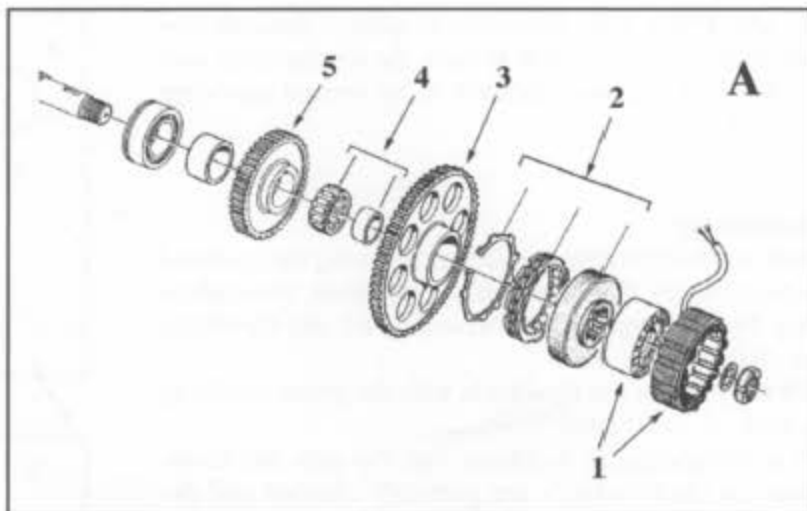

WARNING: This operation is quite a delicate one so, if possible, it is best to have the overhauling carried out by the manufacturer or by special servicing centres.

Assembly:

Reassemble the engine shaft, performing the reversed operations to the disassembly sequence, remembering that the interference between pins and flywheels is $+0.015/0.018$ mm.

Fit the pins on the flywheels with the press, applying a load of 70/80 Atm.

It is indispensable to ensure that the pins and housings on the flywheels are perfectly cleaned and degreased, otherwise there is the risk of their moving and causing loss of centering calibration of the engine shaft.

Checking

Shaft centering

Placing a V block under the two central ball bearings, measure the eccentricity at the ends of the engine shaft (A) with a comparator; the maximum allowed eccentricity is 0.03 mm.

If the eccentricity is greater, the shaft must be recentered, tapping the side flywheels with a copper mallet (B).

Small end

The working surface must be in perfect condition. Measure the clearance between the small end and the gudgeon pin which must not exceed 0.05 mm (C), if the clearance is greater it is advisable to change the pin and the connecting rod. This check must be performed before assembling the connecting rod so as to avoid having to reopen the shaft.

Check the parallel position of the gudgeon pin with respect to the surface on which the cylinders rest.

To do this you need to precision metal bars with strictly parallel surfaces, of the same height, under the gudgeon pin; check that the gudgeon pin rests on both parts (D).

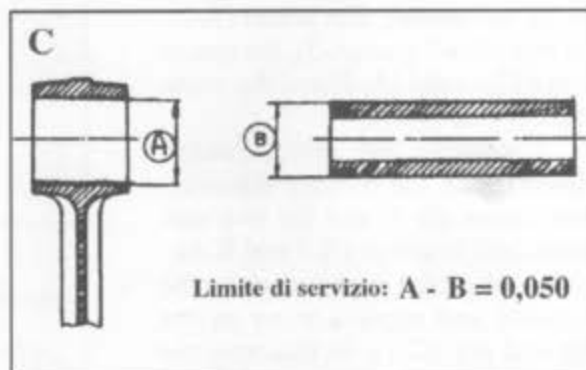
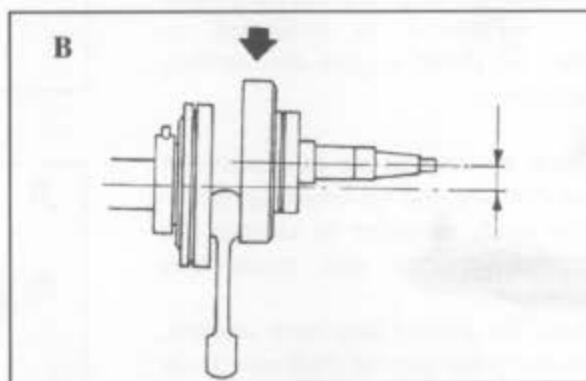
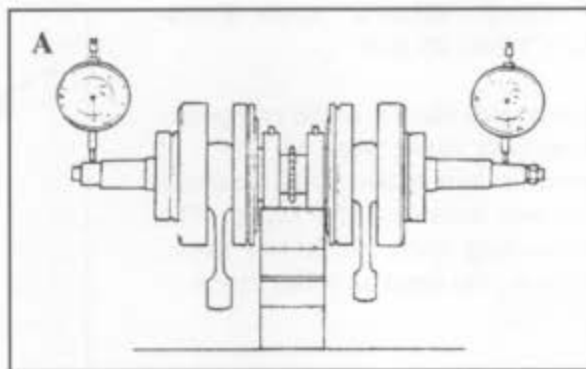

Big end

Check that the clearance between the big end, the rollers and the crank pin is less than the maximum allowed value of **0.06 mm**.

To perform this check, place the engine shaft on two V blocks so as to prevent it from moving, then place the feeler of the comparator against the big end, in the middle, pulling the connecting rod forward and back (A).

This check must be performed for various positions of the connecting rod on the crank pin, since wear is not uniform.

To appreciate the clearance better, clean petrol may be syringed into the roller bearing of the big end through the oil output side channels; then blow with compressed air to remove the oil present. As already stated, the maximum allowed value is **0.06 mm**. After checking, remember to lubricate the roller cage again before assembly.

At assembly, the side clearance between connecting rod and flywheels, measured with a feeler gauge, is between 0.30 and 0.40 mm; the wear limit is 0.45 mm (B).

Warnings for fitting the engine shaft on the bottom casing.

When placing the engine shaft in the bottom casing, ensure that the ring nut of the bearing matches perfectly with the groove in the bearing housing on the casing. (C).

- The distribution chain must be fitted on the central pinion of the engine shaft in such a way that, when the shaft is turned until the left pinion is at top dead centre, the two ends of the chain, held vertically above the pinion, held vertically over the pinion, are of the same length. The chain passes between the pinion and the pin which joins the external rings of the bearings.

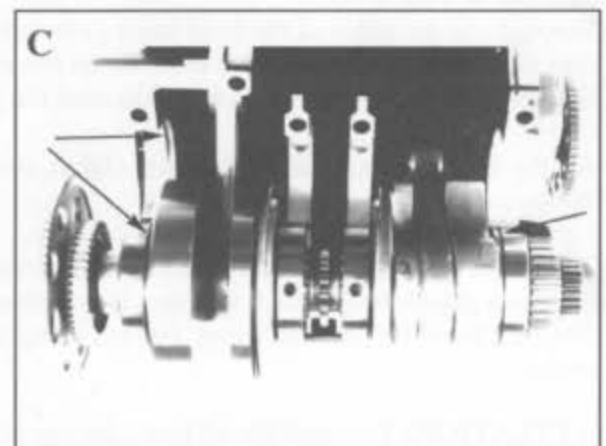
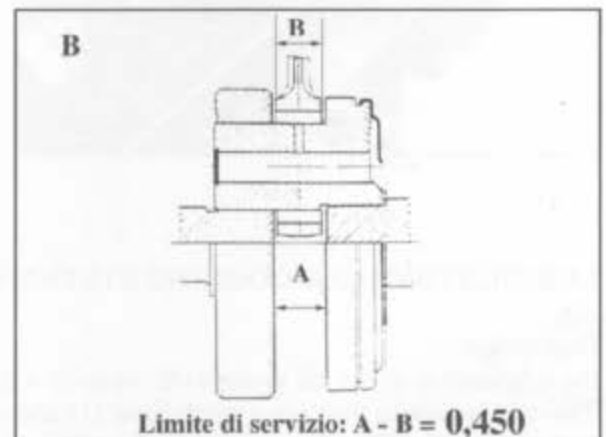
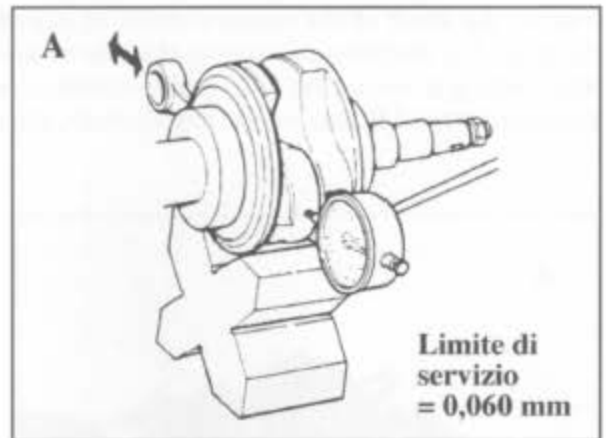

Fitting the shaft of the counter-rotating masses

After having installed the engine shaft in its housing, install the shaft of the counter-rotating masses (A), when fitting it, be careful to align the reference marks on the two gears that control the shaft of the counter-rotating masses (B, one on the engine shaft, the other on the masses shaft).

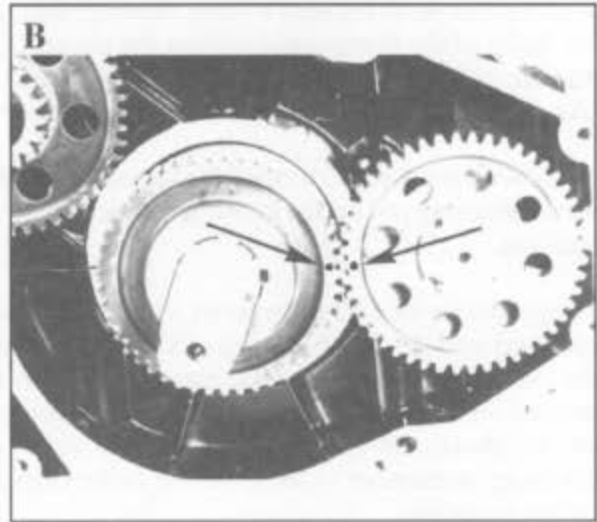
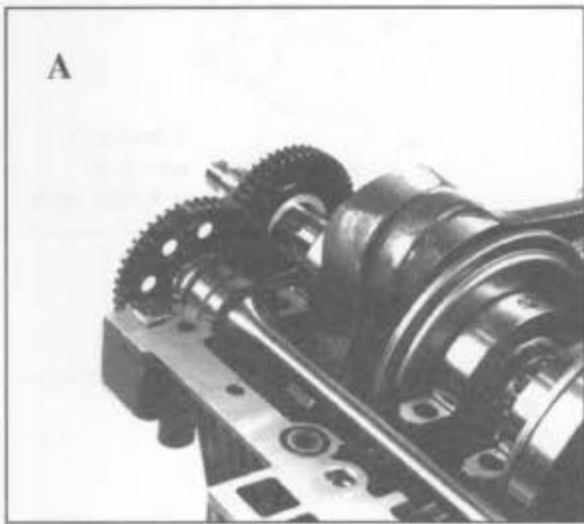
**LUBRICATION AND COOLING SYSTEM (A).****Operation**

the lubricant is in the oil sump with capacity 4 lt. The gear pump (2) is on the left of the engine.

The oil is taken in through a mesh filter (1) and sent to an overpressure valve (3), after which it passes into a cartridge filter (4). Through a tee, the oil pipes branch out to the two external radiators (5-6), after which they join up, by means of a coupling, with the internal pipes in the head (7); through these they go out to the various head components and in particular to the camshafts (8) and the camshaft supports (9).

The valve tappets (11-15) are lubricated through other passages and oil is sent close to the combustion chamber to cool it (12).

Through the passages of the head studs (10) and other passages, the oil returns to the sump and part of it is sent through special conveyers to lubricate the engine shaft (13).

Other spraying devices direct the oil to cool the piston skirt (14).

All the engine components (gearbox, clutch, primary transmission) are splash-lubricated by the oil in the sump.

The motor casing is provided with an overpressure breather (B) which requires no maintenance; inside it there is a plastic bush which acts as a labyrinth seal.

The oil should be checked every 500 km using the dipstick, or the sight glass for the first series of motor-cycles (C).

ATTENTION: To check the oil level, the cap of the dipstick must rest in the seat without being screwed in.

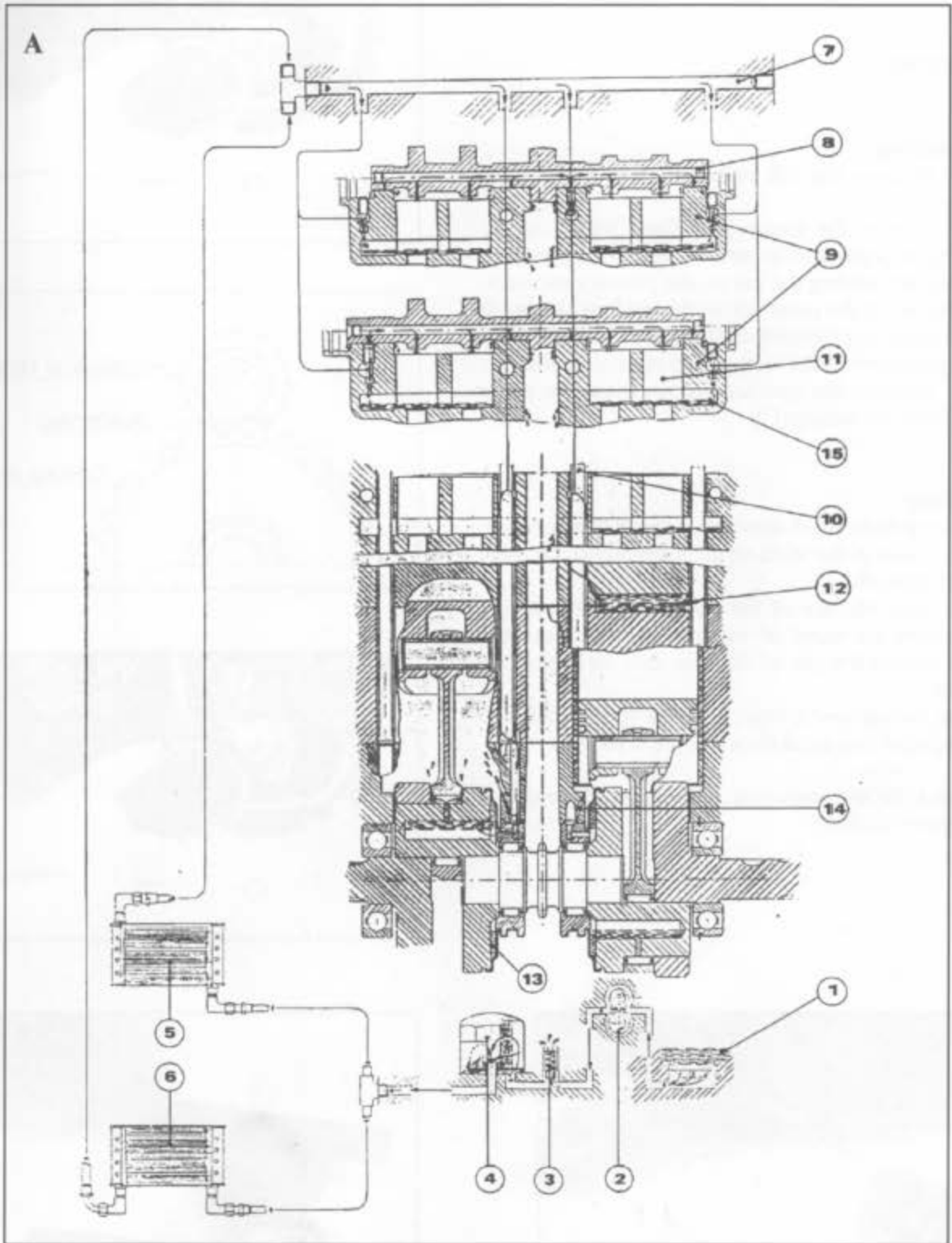

OIL PUMP

Dismantling

- Remove the left casing after having drained off the oil;
- remove the crown gear fixed with a seeger ring (A) (it is possible to remove the crown gear even without unscrewing the nut on the primary transmission pinion: at the point where the nut lock washer is folded over, it is possible to slip the crown gear teeth of the pump out of the teeth on the control pinion (B);
- unscrew the four screws, removing the pump body from the casing (C).

Checking

The pump body must show no signs of wear or scoring; the sides of the teeth on the gears and shafts must be very smooth.

The contact surface of the oil pump on the casing must show no signs of wear; if it is considerably worn, extract the pin of the idle gear and grind the surface.

All the clearances at wear limit for the oil pump in both a radial and axial direction are 0.10 mm.

To check the measurement, proceed as illustrated in the figures (D-E-F).

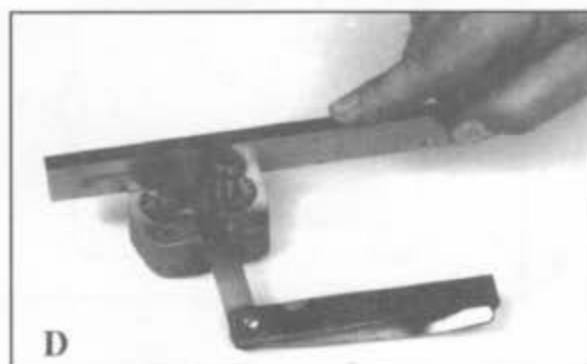
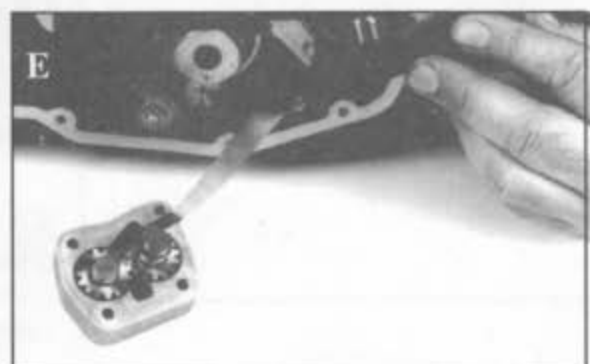
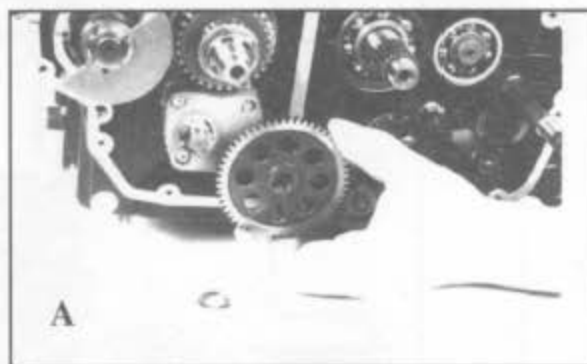
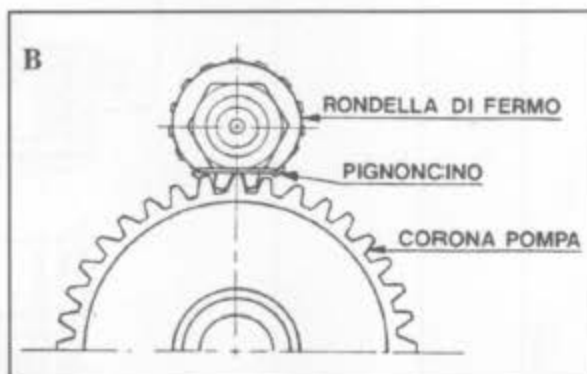

Assembly

Spread a film of sealant on the joining surface between the pump body and the casing. Once the screws have been secured, ensure that the internal gears turn without friction.

STARTING FREE WHEEL

Disassembly

After having drained off the oil, remove the alternator flywheel cover, insert a soft metal bar between the drive gears of the counter-rotating shaft and unscrew the polar wheel retaining ring nut with the special spanner **06100800023** (A); in the second series the ring nut has been replaced with a M 17 nut;

- slip off the free wheel and the gear (B);
- if necessary, separate the body of the free wheel from the gear, removing the circlip (C-1).

Checking

- The gear teeth must be in perfect condition;
- the rollers of the free wheel (D-2) and the working track (D-3) must show no signs of wear;
- the track diameter is 51.718 mm, at wear limit 51.695 mm;
- working track diameter mm. 68,337, at wear limit 68,360;
- check the clearance between the pin and the double gear located between the starting motor and the free wheel.

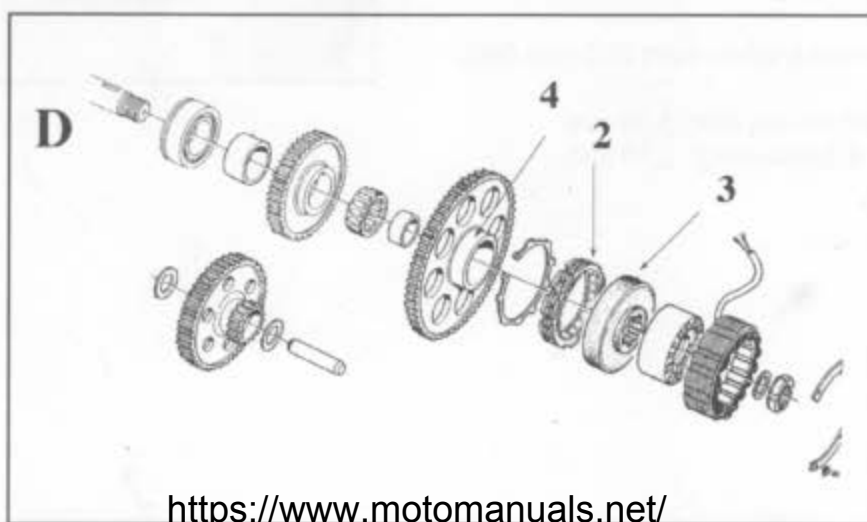
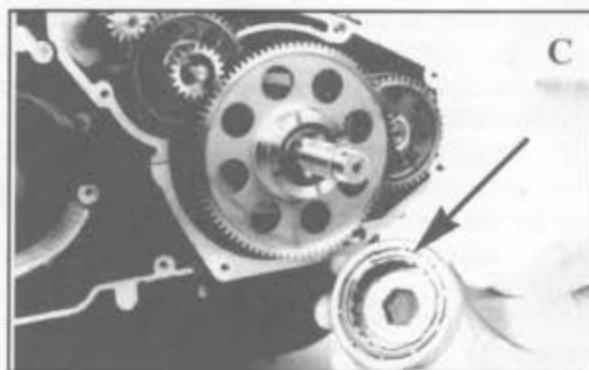

PRIMARY TRANSMISSION AND CLUTCH

Dismantling

To overhaul the primary transmission and the clutch it is not necessary to remove the engine block from the frame.

- Remove the plug of the PK electronic injection sensor (A-1);
- remove the PK rotor inspection cover (A-2), then remove the PK rotor (A-3);
- remove the gear control lever (B); it is useful to make a mark on the lever and one on the pin so that they can be reassembled in the original position;
- drain off the oil;
- unscrew the 10 allen screws and tap gently on the cover with a plastic mallet to detach it from the casing. When removing the cover, pay attention to the gear lever pin which remains attached to the motor block (C);
- remove the clutch pressure plate from the bellhousing, unscrewing the six allen screws, remove the springs and the shim and dismantle the pressure plate (D-E);
- extract the clutch control semi-rod (F);
- unscrew the ring nut, holding the clutch driving plate still, with the special tool **061008000022** (G), unscrew the ring nut with the special spanner **061008000023**, after having raised the lock washer (H). Shortly the ring nut will be replaced with a 17 mm hexagon nut. Remember that the retaining ring nut (or the nut) has a **LEFT-HAND** thread;
- remove the washer and extract the driving plate (I);
- remove the clutch bellhousing after having removed the ground washer (I-1);
- remove the second ground washer located under the bellhousing (I-2).

ATTENTION: the two washers have different thicknesses:

- the washer under the driving disc: 3.30 mm
- the washer under the bellhousing: 2.50 mm.

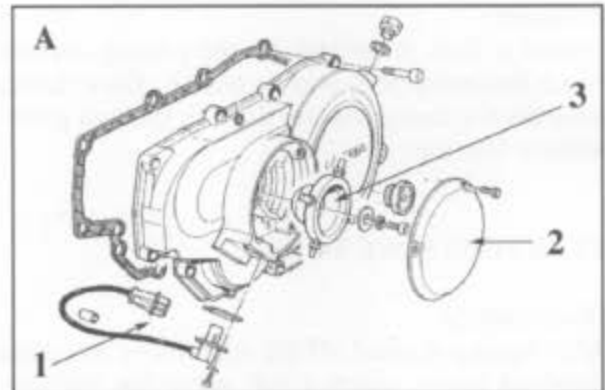

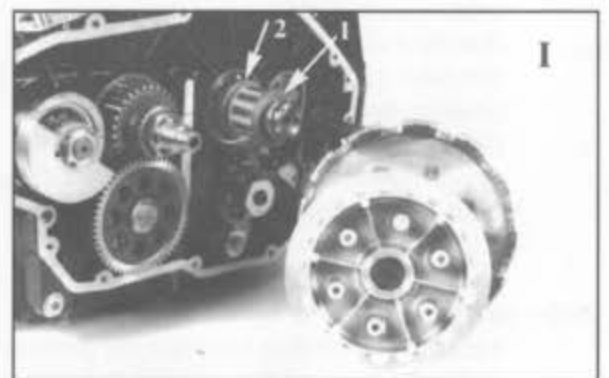
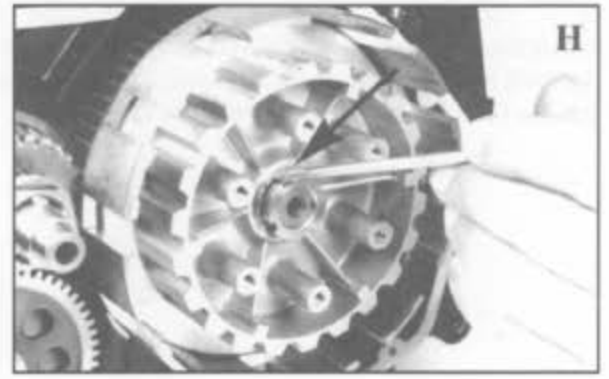
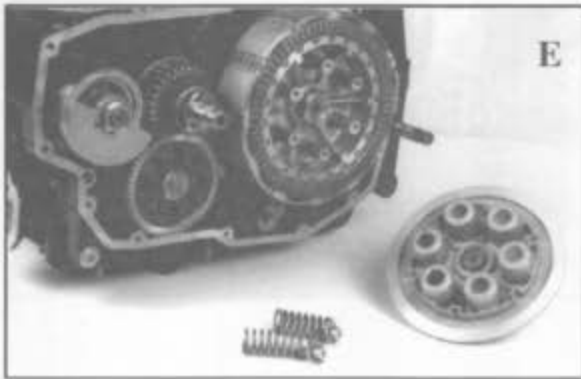
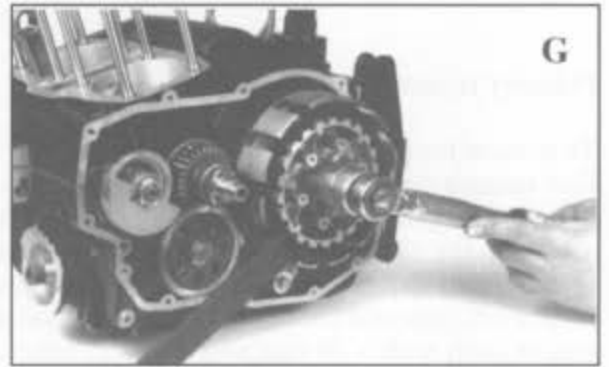
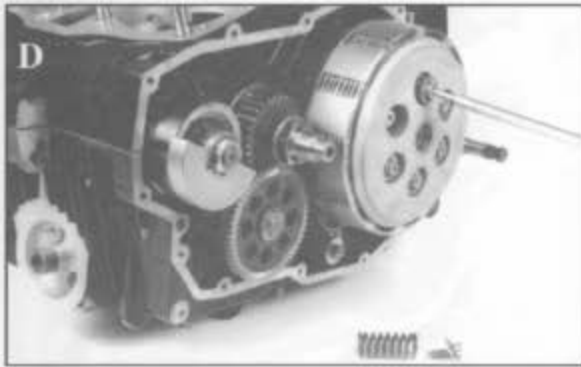

Primary transmission pinion

To remove the primary transmission pinion you must first remove the seeger of the oil pump gear (A-1) with special pliers; to remove the gear, position the gear with the clamp as in fig. 'B', then straighten the metal clamp and, holding the primary transmission pinion still, unscrew the nut fastened to the end of the engine shaft with a 30 mm ring spanner, remembering that the nut has a **RIGHT-HAND** thread (A-2).

The oil pump control pinion can be extracted by hand without any difficulty (A-3);

- being careful not to damage the cage of the crankshaft bearing, lever symmetrically with two screwdrivers and extract the primary transmission pinion fitted on the grooved profile of the shaft.

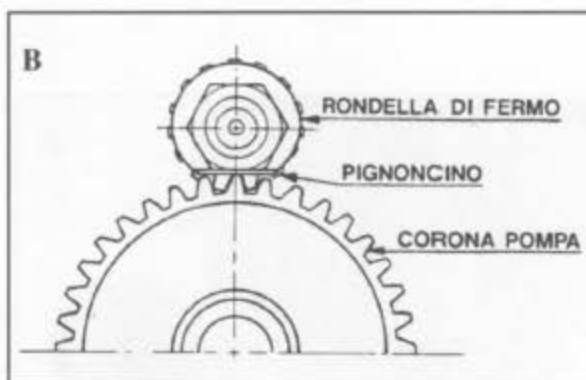
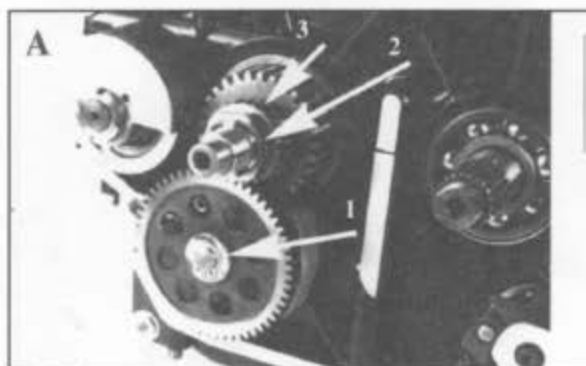

List of possible causes of clutch malfunction

The clutch does not release

- worn clutch plates
- distorted clutch plates
- irregular spring tension
- deteriorated engine oil
- too much oil in the crankcase
- excessive wear of the drive hub or of the bellhousing
- fault in the release mechanism

Noisy clutch

- excessive clearance between the primary transmission gears
- damaged teeth on the primary transmission gears
- excessive clearance between the ends of the driving plates and the clutch bellhousing
- gear or clutch bellhousing support bearings are worn
- metal particles on the gear teeth

The clutch slips

- clutch plates worn or overheated
- weakened springs

- fault in the release mechanism
- excessive wear of the hub or the bellhousing

Clutch control rod

Check linearity of the control rod after having positioned it between two tailstocks (A). The eccentricity of the rod must not exceed 0.3 mm.

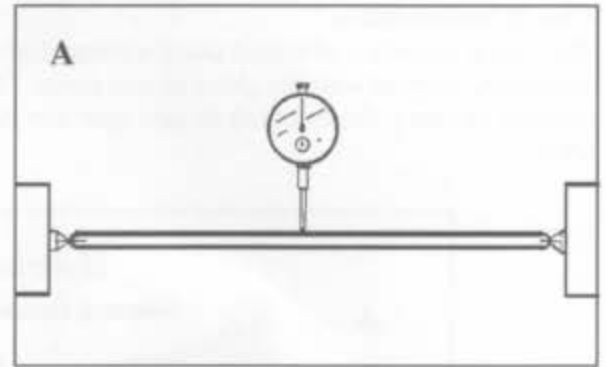

Clearance between the clutch bellhousing and the driving plate

Insert the driving plate (B-1) in the bellhousing (B-2) and measure the existing clearance with a feeler gauge (B-3). The result "S" must not be greater than 0.6 mm, otherwise the bellhousing must be replaced.

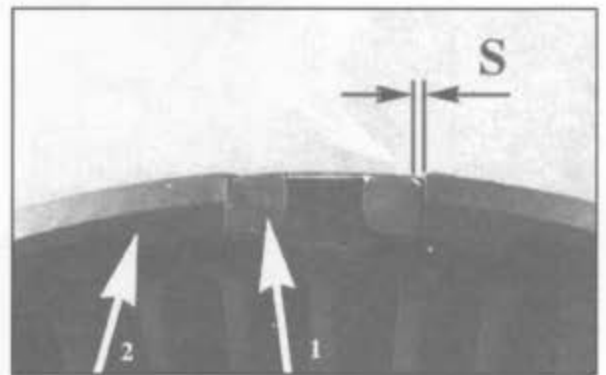

Clutch plates

The lined external clutch plates must not show any signs of burning due to overheating, grooves or deformations.

Measure the thickness of the lined plate which must not be less than 2.8 mm (C).

Lay the plate on a flat surface and check the extent of the deformation with a feeler gauge (D). Working limit 0.2 mm.



Clutch springs

Measure the free length "L" of each spring with a gauge; it must not be less than 39,5 mm (E). The clutch springs must all be the same length.

