

CONTENTS

OVERVIEW AND OPERATION

Identification number, engine number	3
View of vehicle.....	4 - 5
Cockpit, handlebar instrument.....	6
Ignition lock and fork-column lock.....	7
Digital clock	8
Storage box, luggage hook.....	9
Fuel, fuel tank.....	10
Tank cap	11
Lubricating oil tank	12
Side stand, parking stand.....	13

SAFETY TEST

Checklist.....	14
Load and lights	15

RIDING INSTRUCTIONS

Ride safely	15
Ride economically and environmentally	16
Running-in instructions.....	17
Starting	18 - 19
Brakes	20 - 21
Stopping the engine.....	21

SERVICE INSTRUCTIONS

Servicing the scooter / cleaning agents.....	22 - 23
Winter operation and corrosion protection.....	23
Repairing paint damage / servicing the tyres	24
Lay-up commission.....	24
Technical modifications, accessories and spare parts	25

CONTENTS

NOTES ON MAINTENANCE

Transmission oil	26
Checking steering bearing, telescopic fork	26
Adjusting the shock absorber	27
Tyres	28
Front wheel brake	28 - 30
Rear wheel brake	31
Adjusting the play of the twist grip throttle control	32
Cleaning the air filter	33 - 35
Checking the spark plug	36
Fuse	37
Battery	38 - 39
Changing the light bulbs	41 - 43
Adjusting the headlight	44

TECHNICAL DATA

Engine	45
Power transmission	46
Chassis	46
Lubricants and operating fluids	47
Electrical equipment	47
Dimensions and weights	48

WARRANTY AND SERVICE DATA

Warranty conditions	49
List of wear items	50 - 51
Inspection plan	52 - 54
Proof of maintenance	55 - 56

SUMMARY AND OPERATION

Identification number



NOTE

The description for right- and left-hand side is viewed from the driver.

The identification number (1) is located on the frame below the front cover.

Chassis number

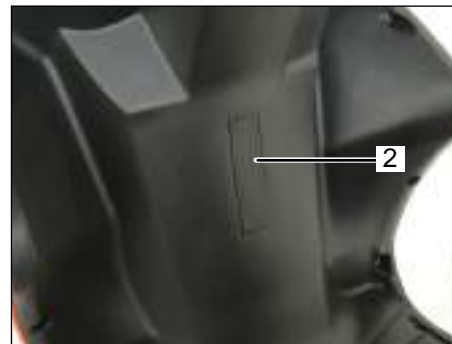

The chassis number is located on the frame behind the cover (2).

Engine number

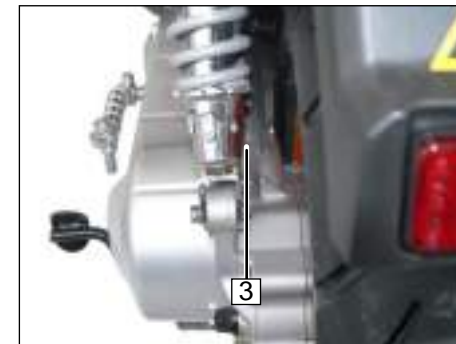

The engine number (3) is located on the left-hand side.

Key

With the scooter you get two separate indefinite keys for:

- **Ignition lock, lubricating oil tank, storage box and tank cap.**

Keep the spare key at a safety place.

OVERVIEW AND OPERATION

Right-hand side view

- 1 Storage box with tool kit
- 2 Luggage hook
- 3 Cover for lubricating oil tank
- 4 Battery box and fuse
- 5 Ignition- and fork-column lock
- 6 Brake fluid container for front wheel brake
- 7 Handbrake lever for front brake
- 8 Spark plug



OVERVIEW AND OPERATION

Left-hand side view

- 9 Handbrake lever for rear brake
- 10 Cockpit
- 11 Tank cap
- 12 Transmission oil filler screw
- 13 Kick starter
- 14 Parking stand
- 15 Air filter
- 16 Side stand



OVERVIEW AND OPERATION

Cockpit

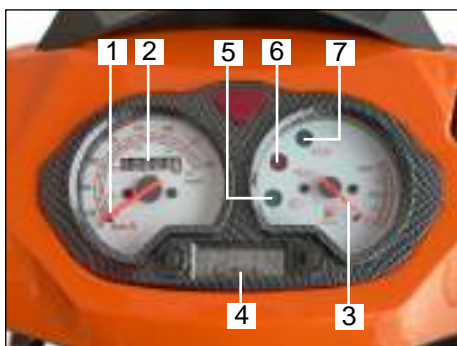

Handlebar instrument, left

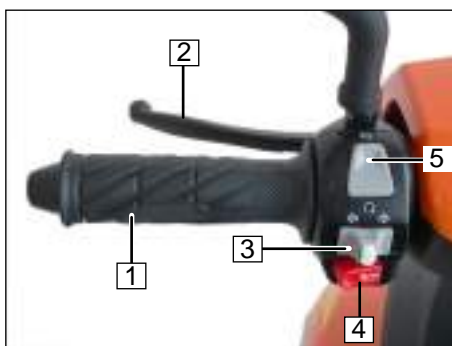

Handlebar instrument, right

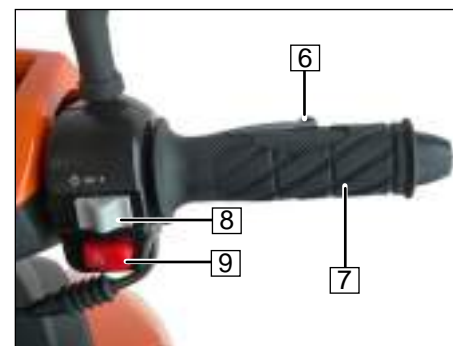

Instruments

- | | |
|------------------|------------|
| 1 Speedometer | km/h / mph |
| 2 Odometer | km |
| 3 Fuel indicator | |
| 4 Digital clock | |

Instrument lights

- | | | |
|--|--|-------|
| 5 Low beam indicator | | green |
| 6 Oil level - two stroke oil indicator | | red |
| 7 Left and right direction indicator | | green |

- | |
|--|
| 1 Fixed grip |
| 2 Handbrake lever for rear brake |
| 3 Direction-indicator switch |
| ⇐ Switch to the left:
Left indicator on |
| ⇒ Switch to the right:
Right indicator on |
| Push button for switch off |

- | | |
|---|---------------------------|
| 4 | Push-button: horn |
| 5 | Emergency off switch |
| | The engine does not start |
| | The engine starts |

- | | |
|---|----------------|
| 6 Handbrake lever for front brake | |
| 7 Throttle | |
| 8 Light switch | |
| ● Off | |
| Position light | |
| Position light and driving light low beam | |
| 9 | Starter button |

CAUTION
The **EMERGENCY OFF** switch (5) is a safety device and should normally be in position .

Ignition- and fork-column lock

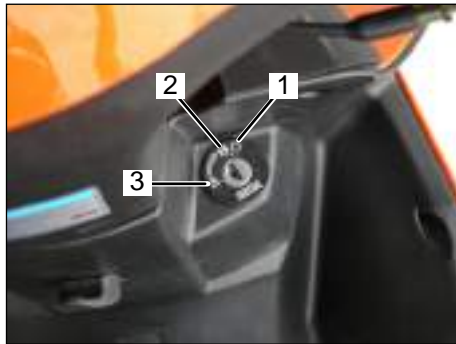

Key positions



NOTE

Activate the parking light only for a limited period. Take into account the charge of the battery.

The key can be removed in positions  and



(1) Operating position

Ignition and all circuits activated.



(2) Ignition off

Fork column not locked (handlebars can be freely turned to the left or right).



(3) Fork column locked and Ignition off

Turn the handlebar to the left as far as to the stop.

Push and turn the key to the left until it is in the LOCK  position. The fork column is now locked.



WARNING

While riding, do not switch the ignition off  !



NOTE

Keys

With the scooter you get two indefinite ignition keys. Keep the spare key at a safety place.

OVERVIEW AND OPERATION

Digital clock



NOTE

The Cockpit is supplied by the vehicle battery. The display is only visible when the ignition is on.
After disconnecting and reconnecting the battery the clock time needs to be reset.

- M Mode for:
date or time
- S Set for:
date and time

Mode and Set

- Button M press 1 time
Changing between date and time
- Button M press 2 time
until the month appears
The month value can be set by pressing button S
- Button M press 3 time
until the day appears
The day value can be set by pressing button S
- Button M press 4 time
until the hours appears
The hours value can be set by pressing button S
- Button M press 5 time
until the minutes appears
The minutes value can be set by pressing button S
- Button M press 6 time
End of mode. Date and time is set and (:) flashes.

- Button S press 1 time
The date value appears for a moment
- Button S press 2 time
The seconds are shown.
Press the button S again to return to the time value.

Storage box

- Do not store valuables in the box.
- Make sure that the seat has been locked completely after it was pressed down.
- Take out valuables before washing to avoid wetting these objects.
- Do not place thermal sensitive objects in the box because of engine's heat and high temperature.



Unlock

- Insert the ignition key (1) into the lock turn and press down the key to the right or left direction (OPEN).

Lock

- Press down the seat (2) until the lock is engaged.
- Pull out the ignition key.

Never leave the key in the storage box.



WARNING

After the seat is closed check if its locked firmly! -Risk of accidents!

Maximum load capacity: 10 kg

Luggage hook



Use the hook (1) only for small baggage pieces.



WARNING

Maximum load capacity: 1.5 kg

Do not transport bulky loads.

OVERVIEW AND OPERATION

Fuel, fuel tank

WARNING

Fuel is highly inflammable and can explode. Do not smoke or bring a naked flame near the fuel tank.

Fuel expands under the influence of heat and the sun. Therefore, never fill the tank to the brim. Never fill the tank while the engine is running.

Never bring a glowing cigarette or naked flame near an open tank, because fuel vapour could suddenly ignite.

Fuel stock, tanking



NOTE

The fuel indicator (1) is active when the ignition is turned on.

The scale with the tank symbol  remembers for a tank stop.

0 = Empty

100 = Full

Don't run down the fuel tank until it is empty.

Filling up with fuel

- Use only premium lead-free fuel (min. 95 octane)

Tank cap

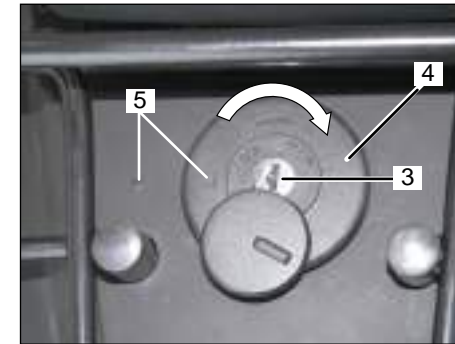
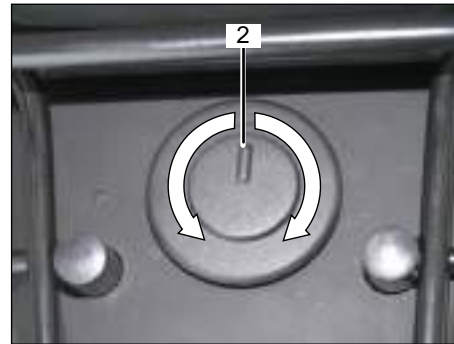

NOTE

The tank cap (1) is located behind the seat.

Unlock:

- Turn the cover (2) to the left or right side.

- Insert the ignition key in the lock (3) turn to the left and open the tank cap (4).

Lock:

- The marks (5) must be in front before closing the tank cap.
- Close the tank cap by turning with the ignition key to the right and pull out the key.
- Close the cover (2).

OVERVIEW AND OPERATION

Lubricating oil tank

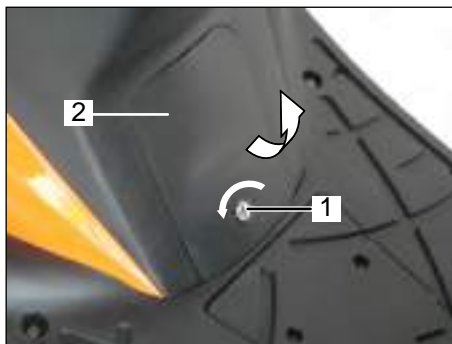

CAUTION

Check the oil level during every tanking and replenish if necessary.

If the oil level is too low, the indicator (1 ) will light up. Replenish two stroke oil within the next 50 km.

Damage caused by not observing this instruction will not be covered under warranty.

Filling up with lubricating oil

- Use only mineral - or semi-synthetic oil for separate injection:
API-Norm TC, JASO-Norm FC.

- Insert the ignition key in the lock (1) turn to the left and open the inspection cover (2).

- Open the oil cap (3) and replenish max. to the mark (4) of the oil filler.
- Tighten the oil filler cap by hand.
- Lock the inspection cover (2) with in igh-tion key.

Side stand and parking stand

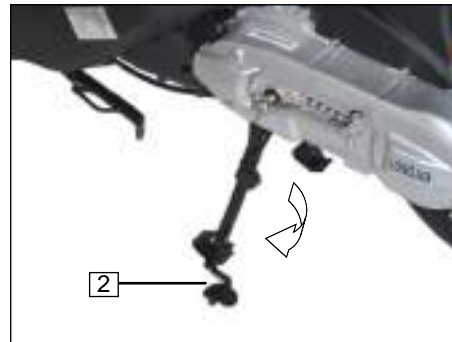

Propping up the scooter on the side stand.

⚠ WARNING
Always make sure that the stand is resting on firm ground. On sloping roads, always park the scooter facing uphill.
It is essential that the side stand is folded up before starting off! -Risk of accidents !

Side stand



NOTE

The scooter is equipped with a side stand switch. If the side stand is folded up the engine is shut off and will not start.

- Switch off the engine.
- Put your left hand on the left-hand handlebar grip.
- Hold with your right hand the holder grip (3).
- Fold out the arm of the side stand (1) as far forward as it will go and stop by foot.
- Slowly tilt the scooter to the left until its weight is supported.

Parking stand

- Switch off the engine.
- Put your left hand on the left-hand handlebar grip.
- Hold with your right hand the holder grip (3).
- Push the parking stand (2) down until the two skids are on the ground.
- Put your full body weight on the operating mandrel of the main standard.
- Pull the scooter towards the rear and simultaneously upwards onto the parking stand.
- Check that the scooter is standing firmly.

SAFETY TEST

Checklist

Before each ride, carry out a safety check using the checklist.

Take the safety check seriously. Carry out maintenance activities before you start your ride or ask a specialized Sachs dealer to do so. This will provide you with the certainty that your motorcycle corresponds to traffic regulations. A technically faultless motorcycle is a basic requirement for the safety of both yourself and other road users.

Before starting your ride, check the following:

- Steering (smooth and free of play)
- Clutch lever play
- Lubricating oil quantity
- Fuel quantity
- Front brake
- Rear brake
- Tyres (profile and pressure)
- Telescopic fork
- Load / lights
- Total weight
- Lights
- Brake fluid (level)
- Brakes (operation)

In case of problems or difficulties, contact a Sachs dealer, who will do everything possible to assist you.



WARNING

While the engine is running or the ignition is on, do not touch the ignition system.



FIRE HAZARD

The exhaust system becomes very hot. While riding, idling or parking, make sure that no inflammable materials (e.g. hay, leaves, grass, coverings or luggage, etc.) can come into contact with it!

Load / lights **WARNING**

For the sake of your safety, use only original Sachs accessories or products released by Sachs.

Sachs cannot judge for each third-part product whether it can be safely used in combination with your Sachs motorcycle. Nor can a official approval give such a guarantee in all cases, since the test scope is not always sufficient.

**NOTE**

Sachs accessories and Sachs-approved products as well as qualified advice are available from all specialized Sachs dealers.

Correctly loaded

- Make sure that the left-right weight distribution is balanced.
- Check that fastenings are correct and tight.
- Do not transport bulky loads.
- Do not cover the lights.

 **WARNING**

The total allowable weight may not be exceeded.

Check the tyre pressure.

Checking the lights **WARNING**

Before any ride, check the operation of all lighting components.

- Check that the headlamps and lenses are clean.

Ride safely**CAUTION**

Riding safety is largely also determined by the manner of riding.

Therefore:

- Put on a tested/approved safety helmet and correct close the buckle.
- Wear suitable protective clothes.
- Rest your feet on the footrests.
- Do not ride if your riding ability has been compromised.

Your reactions can be adversely affected not only by alcohol, but also by drugs and medicines.

- Strictly observe all traffic regulations.
- Always adapt your riding speed to the traffic and road conditions.

On smooth, slippery roads take into account that your riding stability and braking power are limited by the grip of the tyres on the road top.



RIDING INSTRUCTIONS

Ride economically and be aware of the environment

Fuel consumption, environmental pollution and wear of engine, brakes and tyres depend on various factors.

Your personal riding style is highly determinant for economical fuel consumption and exhaust gas and noise generation.

While idling, the engine takes a long time to warm up to operational temperature. In the warm-up phase, however, the wear level and pollutant emissions are very high. It is therefore best to start riding immediately after start-up.

Avoid rapid acceleration

Open the throttle not further than needed, in order to reduce fuel consumption as well as pollution and wear levels.

Do not use excessive revs; change up as soon as possible and do not change down until it is necessary to do so.

Ride as evenly as possible and look ahead as far as possible.

Unnecessary acceleration and hard braking cause high fuel consumption and increased pollution levels.

Turn the engine off when waiting in traffic.

Different riding conditions affect fuel consumption. The following conditions are unfavourable for fuel consumption:

- High traffic density, especially in big cities with many stops for traffic lights.
- Frequent short rides with repeated starts and warm-ups of the engine.
- Riding in a column of motor cycles at low speed, meaning riding with relatively high revs.

Plan rides ahead of time in order to avoid heavy traffic.

Fuel consumption is also affected by conditions that are out of your control, for instance, poor road condition, hills, riding in winter.

Observe the following aspects for economical fuel consumption:

- The planned inspection intervals must be closely observed.
- Regular service by a specialized Sachs dealer will guarantee not only continued operability, but also economical fuel consumption, low environmental pollution and a long lifespan.
- Check the tyre pressure every two weeks.

Low tyre pressure increases rolling resistance. This increases fuel consumption and tyre wear and adversely affects riding behaviour.

- Continually check fuel consumption.
- Frequently check the lubricating oil.



Running-in

Running-in instructions for engine and transmission



CAUTION

Excessive revs while running-in the engine increases the wear of the engine. Engine faults during the running-in period must be immediately reported to a specialized Sachs dealer.



NOTE

During the running-in period, ride in frequently changing load and rpm ranges. Select winding and slightly hilly routes. Avoid constantly low rpm counts and full throttle under load.

- **During the first 500 km:**
Less than 1/2 throttle.

- **Up to 1.000 km:**
Less than 3/4 throttle.



CAUTION

The first inspection must be carried out immediately after the first 1.000 km.

You can save yourself delays by making an appointment with a specialized Sachs dealer in advance.

Running-in new tyres



CAUTION

New tyres have a smooth surface. They must therefore be roughened by carefully running them in at various slanted positions.

Only then will the surface obtain its full grip!

Running-in new brake linings



WARNING

New brake linings must be run-in and will not have their full friction power until after 500 km.

The slightly reduced braking effect can be compensated for by an increase in the pressure on the brake lever.

During this period, avoid unnecessary hard braking actions!

RIDING INSTRUCTIONS

Starting with the electric starter

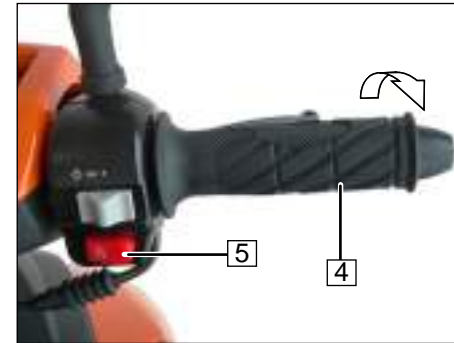

⚠ WARNING
Propping up the scooter with the parking stand. Operate the rear handbrake lever to avoid a moving of the scooter. Avoid high engine rpm's while the vehicle is standing still, otherwise the clutch will engage.

👉 NOTE
The scooter is equipped with a side stand switch. If the side stand is folded up the engine is shut off and will not start.

Before starting

- Propping up the scooter with the parking stand.
- Turn the ignition lock (1) with the ignition key to its operating position ↻.
- Do not open the throttle (4).
- Pull and hold the handbrake lever (2).
- Operate the start button (5).
- If the engine can not be started after the starter motor is running for 3-5 seconds, open the throttle (4) 1/8 - 1/4 turns and start again.
- Push the scooter off its parking stand.
- Mount the scooter.
- Release the brake before riding.

👉 CAUTION
If the engine won't start immediately, release the start button, wait a few seconds and push it again. Each time, push the start button for just a few seconds in order to save the battery. Never push the start button for more than 10 seconds.

⚠ WARNING
Never allow the engine to run in an enclosed space. Exhaust gases are highly toxic and can kill.

Starting with kick starter

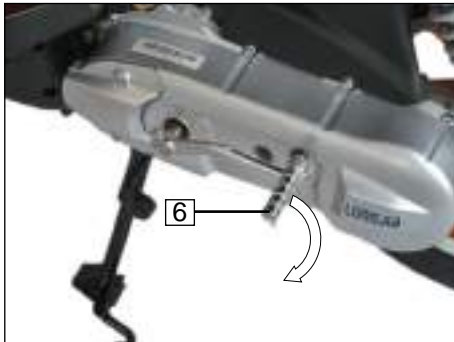

- Propping up the scooter when operating the kick starter.
- Turn the ignition lock (1) with the key to its operating position ↻.
- Do not open the throttle (4).
- Depress the kick starter lever (6) quickly and the engine will start.
- After the engine is running return the kick starter lever to its normal position.



CAUTION

The **EMERGENCY OFF** switch (3) is a safety device and should normally be in position ↻.

↻ **ON:**

Switch downwards. The engine will start when the kick starter lever is used.

⊗ **OFF:**

Switch upwards. The engine will not start.



CAUTION

After starting the engine, check that the kick starter lever (6) is returned to its normal position.



NOTE

Use the kick starter from time to time to maintain its function.

RIDING INSTRUCTIONS

Braking

Wet brakes

Washing the motorcycle or riding through water or rain can delay the braking effect due to wet or (in winter) ice-covered brake discs and linings.



WARNING

The brakes must first be operated until they are dry

Salt film on the brakes

When riding on salted streets without braking for a while, the full braking effect may be delayed.

Oil and grease



WARNING

The brake discs and linings must be free of oil and grease!

If the motorcycle is not used for a while, a rust film may form on the brakes and thus increase the braking effect. A thick rust film can cause the brakes to lock up. When setting out on a ride after a long lay-up period, carefully operate the brakes several times until they work normally.



NOTE

Make sure you practice braking for emergency situations, but do so where you will not pose a risk to yourself or others (e.g. a deserted parking area).



WARNING

Operate the brakes to grind off the salt deposited on the brake discs.

Dirty brakes

When riding on dirty streets, the braking effect can be delayed due to dirty brake discs and linings.



WARNING

Operate the brakes until they are clean. Lining wear is increased by dirty brakes!

Braking



Braking

The front brake and rear brake are operated independently from each other. The front brake is operated via the right-hand brake lever (1) on the handlebars, and the rear brake is operated via the left-hand brake lever (2).

When stopping or slowing down, release the throttle gas and operate **both** brakes at the same time.

On tight curves, sandy / dirty streets, wet asphalt and icy roads, use the front brake carefully: if the front wheel locks, the bike will slide sideways. Brake with care. Locked wheels do not have much braking effect and can lead to skidding / crashing. In principle, do not brake on a curve, but before the curve. Braking on a curve increases the danger of sliding.

Stopping the engine

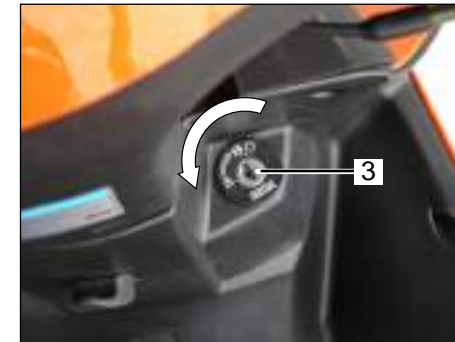

- Turn the ignition lock (3) with the ignition key to the position .
- Pull out the ignition key.

SERVICE INSTRUCTIONS

Servicing the motorbike / cleaning agents



NOTE

Regular, expert service will help maintain the value of your motorcycle and is a condition for guarantee claims for corrosion and other such damage.



CAUTION

Rubber and plastic parts will be damaged by caustic or penetrating cleaning agents or solvents.

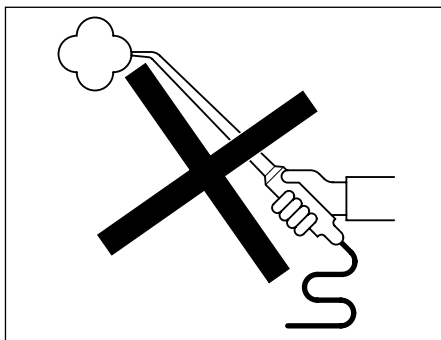

WARNING

Always carry out a brake test after cleaning and before starting a ride!



CAUTION

Do not use steam or high-pressure jet devices!
Such devices can damage seals, the hydraulic braking system and the electrical system.

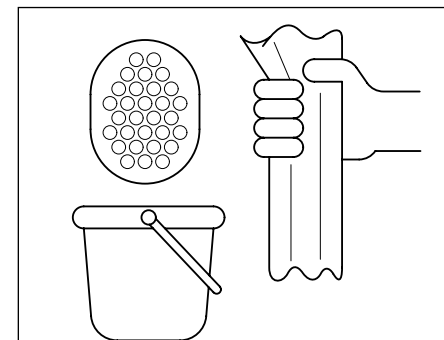

CLEANING

- To wash the motorcycle, use a soft sponge and clean water.
- Afterwards, dry off with a polishing cloth or chamois.
- Do not wipe off dust or dirt with a dry cloth, to avoid scratching the paint or covering.

SERVICE INSTRUCTIONS

Servicing the motorbike / cleaning agents

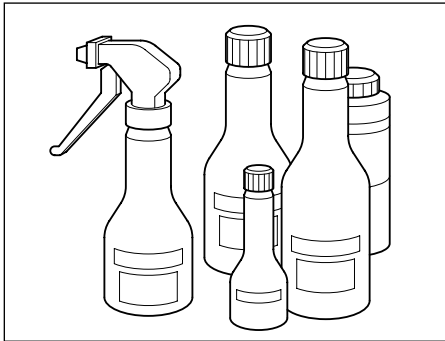

PRESERVATION AGENTS

When necessary, the motorcycle must be preserved with commercially available preserving and cleaning agents.

- By way of precaution (especially in winter), regularly treat parts liable to corrosion with preservation agents.



CAUTION

Never use paint-polishing agents on plastic parts.

- After a longish ride, thoroughly clean the chassis and the aluminium parts and preserve them with a commercially available anti-corrosion agent.

Operation in winter and anti-corrosion protection



NOTE

Protect the environment by using only environmentally friendly preservation agents, and use them frugally.

Use of the motorcycle in the winter can cause considerable damage due to the presence of salt on the roads.



CAUTION

Do not use hot water, which would increase the effect of the salt.

- At the end of each ride, wash the motorcycle with cold water.
- Thoroughly dry the motorcycle.
- Treat parts liable to corrosion with wax-borne anti-corrosion agents.

SERVICE INSTRUCTIONS

Repairing paint damage

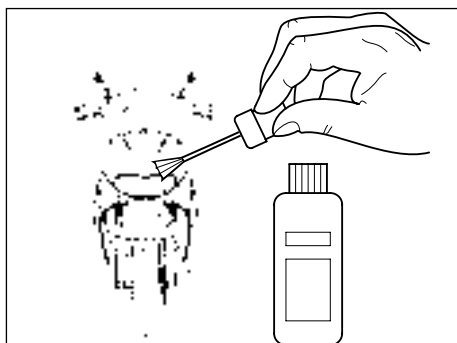

Minor paint damage should be immediately repaired.

Servicing tyres

If the motorcycle is not used for a longer period, it is recommended to support the motorcycle so that its weight is not on the tyres.

You can prevent the tyres from becoming dry and brittle by spraying them with a silicone-rubber treatment. First thoroughly clean the tyres.

Do not store the motorcycle or the tyres in hot spaces (such as a boiler room) for longer periods.



WARNING

A minimum tyre-profile depth of 2.0 mm must be maintained at all times.

Lay-up / commission

Lay-up

- Clean the motorcycle.
- Remove the battery.
Observe the maintenance instructions.
- Spray suitable lubricants onto the brake-lever and clutch-lever joints and the side-standard and main-standard bearings.
- Rub bright / chromium-plated parts with acid-free grease (Vaseline).
- Store the motorcycle in a dry room and jack it up so that its weight is not on the wheels.



NOTE

Combine lay-up / commission activities with an inspection by a Sachs dealer.

Commission

- Remove the preservation agents from the outside.
- Clean the motorcycle.
- Install the charged battery.
- Preserve the battery terminals with terminal grease.
- Check / adjust the tyre pressure.
- Check the brakes.
- Carry out activities according to the inspection plan.
- Carry out the safety checks.

Technical changes, accessories and spare parts

 **WARNING**

Technical changes to the motorcycle can lead to cancellation of the EC operating license.

Should you want to make technical changes, observe our guidelines. This will serve to prevent the motorcycle from being damaged and the traffic and operational safety being retained. A specialised Sachs dealer can carry out these activities with meticulous care.

Always consult a Sachs dealer before buying accessories or making any technical changes.

 **CAUTION**

We recommend using only approved Sachs accessories and original Sachs spare parts for Sachs motorcycles.

This is in your own interests: the safety, suitability and reliability of these accessories and parts will have been tested specifically for Sachs motorcycles.

Although we keep track of the market, we cannot evaluate nor be held liable for the quality of non-approved accessories and parts, even if they have a certificate of acceptance from an officially recognised technical testing/supervision agency, or a license issued by the authorities.

For approved Sachs accessories and original Sachs spare parts, see a specialised Sachs dealer. He will also ensure that they are professionally installed.

NOTES ON MAINTENANCE

Transmission oil

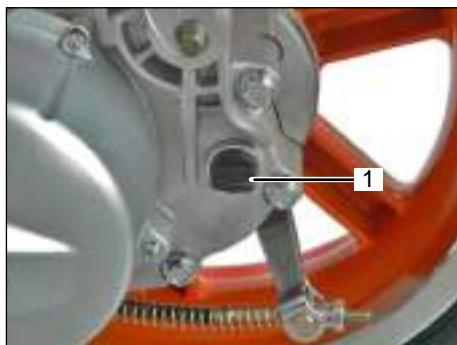

Checking the transmission oil level

- Stop the warmed-up engine, wait for approx. 5 minutes.
- Propping up the scooter on the parking stand.
- Remove the oil filler screw (1) and check if the oil level is below the oil-filler opening.
- If required, replenish transmission oil Hypoid SAE 85W - 140 via the oil-filler opening.
- Tighten the oil filler screw.

Checking the steering bearings



NOTE

The telescopic fork should not jam up when turned and it should swing back lightly to both end positions.

- Pull the hand brake to block the front wheel brake.
- Hold the handlebar with both hands and try to move the handle bar (1) back and forth.

If the fork column bearing shows noticeable play, it must be adjusted by a specialised Sachs dealer.

Checking the telescopic fork

- Pull the hand brake to block the front wheel brake.
- Now pump the fork girders (2) several times up and down using the handlebar.
- The suspension should respond perfectly.
- Check the fork girders for oil leaks.



NOTE

If damage to the telescopic fork or the spring strut is found have the motorbike examined by a professional Sachs dealer.

Adjusting the shock absorber

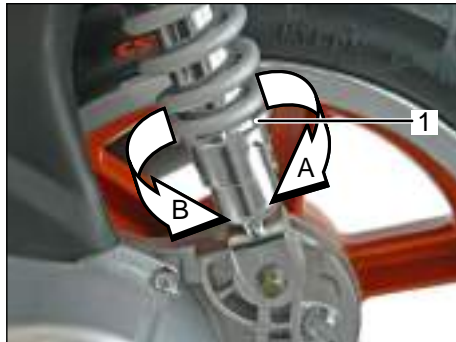

Adjusting the spring preload



NOTE

The spring preload can be infinitely adjusted.

Turn the adjustment nut (1) with a suitable spanner in direction „A“ to increase the spring preload (harder suspension).

Turn the adjustment nut (1) with a suitable spanner in direction „B“ to reduce the spring preload (harder suspension).

⚠ WARNING

Before taking a ride adjust the spring preload of the spring strut according to the total weight!

A = harder

B = softer

NOTES ON MAINTENANCE

Tyre profile

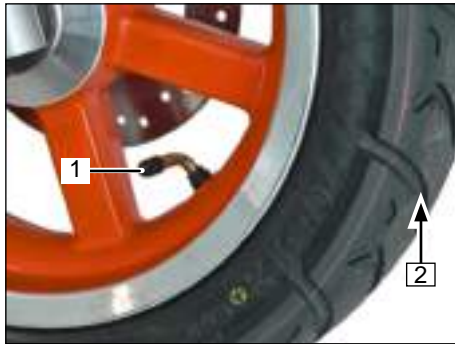

- While the tyres are cold:
- Twist off the valve caps.
- Check/adjust the tyre pressure.
- Twist on the valve caps.

Tyre pressure

Front 2.0 bar
Rear 2.25 bar

Tyre size

The standard scooter is provided with the following tyre sizes:

Front 120/70-12 56J
Rear 130/70-12 56J

Checking the tyre profiles

WARNING

Observe the minimum profile depth prescribed by law.

Never ride without valve caps (1). Firmly tightened valve caps prevent the tyre from suddenly losing pressure.

- Measure the profile depth at the centre (2) of the tyre's tread.

Recommended minimum profile depth:
2.0 mm

Observe the wear marks (3).

Checking the tyre pressure

WARNING

Adjust the tyre pressure according to the total weight load. Never exceed the rated total weight or the bearing capacity of the tyres.

Incorrect tyre pressure will have a considerable effect on the riding properties of the scooter and the lifespan of the tyres.

WARNING

Use only tyres approved by the manufacturer. The use of non-approved tyre brands, types or sizes leads to the operating permit of the vehicle becoming null and void. Use only pairs of tyres produced by the same manufacturer.

NOTES ON MAINTENANCE

Front wheel brake



WARNING

Sudden changes in play or a spongy feel of the brake lever (1) can be caused by faults in the hydraulic system. Do not ride on when in doubt about the operability of the brake system. Immediately consult a Sachs dealer.

Front brake-fluid tank

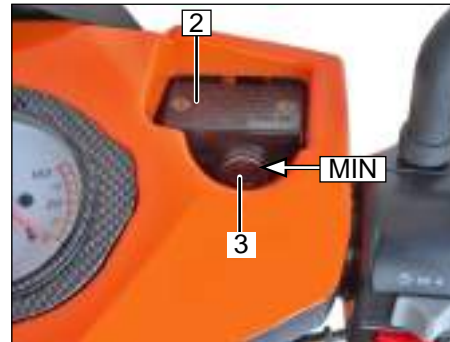

Check the brake-fluid level

WARNING

Every two years, the brake fluid must be changed by a Sachs dealer. The level must not drop below the MIN mark. Use only brake fluid of the DOT 4 classification.

CAUTION

Do not spill any brake fluid on painted or plastic surfaces as it will damage the surface severely.

- Turn the handlebars until the brake-fluid tank (2) is level.
- The brake fluid level (3) should be between the minimum (MIN) and the maximum marking (MAX).
- If air bubbles can be seen, check the brake linings for wear; if necessary, replenish the brake fluid by a SACHS dealer.

NOTES ON MAINTENANCE

Front wheel brake

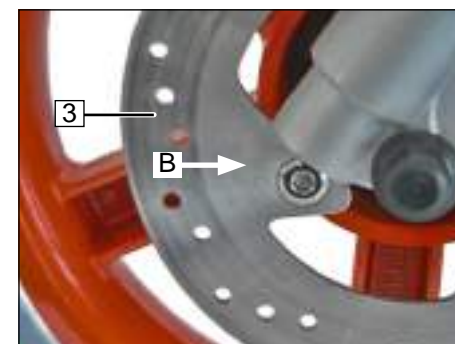
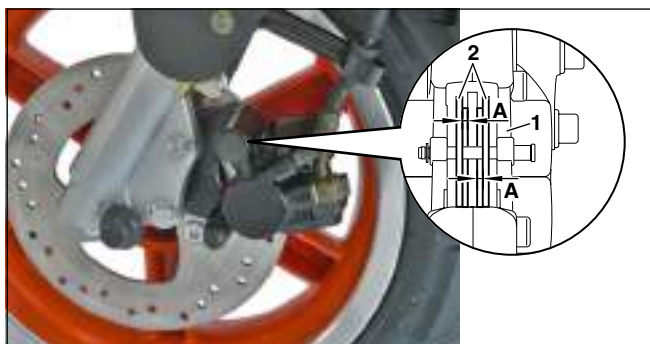

Checking the brake linings



CAUTION

The minimum lining thickness must be maintained.



NOTE

For your own safety, we recommend having activities to the brake system carried out by a Sachs dealer.

- Remove the protective cap (1) at the brake calliper.

- Visually inspect the sight glass (2) at the brake calliper.

- Check the thickness of the brake lining.

Minimum thickness: **A = 2.0 mm**

- If the lining thickness is below the minimum, **have the brake lining (2) replaced by a Sachs dealer.**

Checking the disc brake

- Visually inspect the disc brake (3).

- Check the thickness of the disc brake.

Minimum thickness: **B = 3.0 mm**

- If the disc thickness is below the minimum, **have the disc brake (3) replaced by a Sachs dealer.**

Rear wheel brake

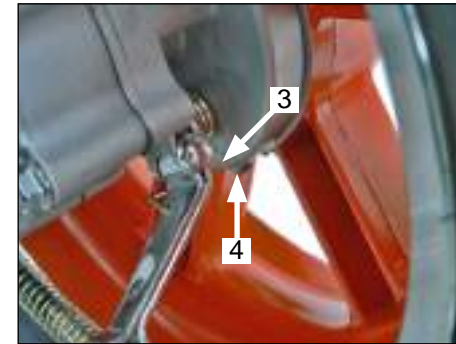
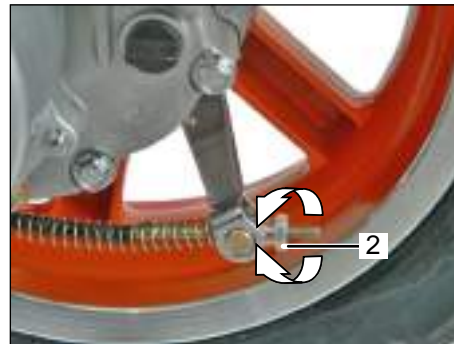
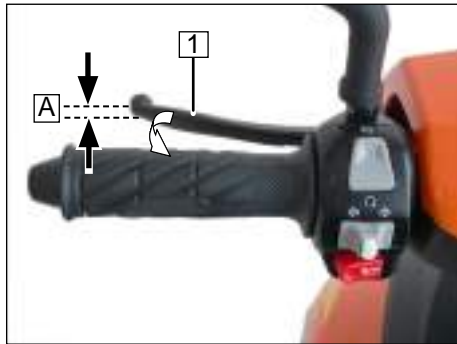

Adjusting the rear wheel brake



CAUTION

For your own safety, we recommend having activities to the brake system carried out by a Sachs dealer.



NOTE

After a longer period of operation, adjustment of the brakes is essential due to natural wear of the brake-shoe linings.

Checking

- An external sign of the brakes needing adjustment is the constantly increasing free travel (A) of the handbrake lever (1) 10-20 mm.

Adjusting

- Screw the nut (2) on the rear-wheel brake onto the brake rod until the handbrake lever reach a free travel of 10-20 mm.
- After this measurement is attained, the brake shoes should be heard brushing against the brake drum.



CAUTION

Have a Sachs dealer check the adjustment.

Checking the brake linings



CAUTION

The thickness of the brake lining may not be lower than the minimum value. Operate the handbrake lever (1) and visually inspect it.

Check the thickness of the lining:

The extension of the wear indicator (3) at the brake lever must be in front of the minimum mark of the scale (4) when the rear brake is depressed.

If the thickness of the lining has fallen below the minimum, have a specialised Sachs dealer replace it.

NOTES ON MAINTENANCE

Adjusting the play of the twist grip throttle control

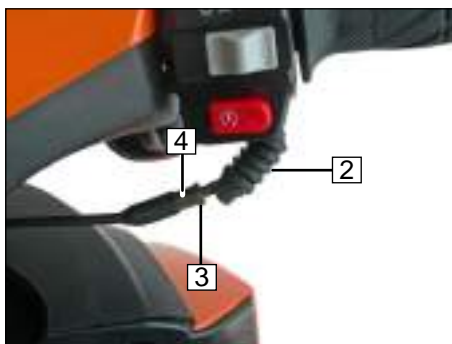
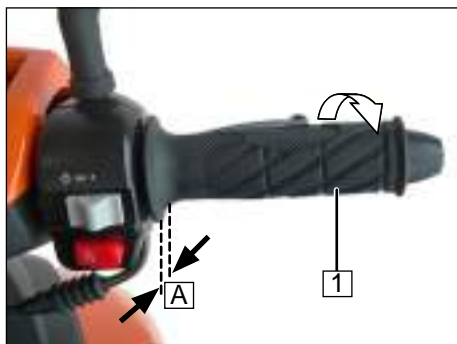

Check:

- Check the throttle cable for light movement by turning the twist grip (1) from closed to open position.
- Move the handlebar to check whether the throttle cable moves freely.
- Check whether the throttle cable is obstructed by other parts.
- Open the twist grip throttle control until resistance can be felt.
- Measure the play.
Nominal value: **A = 1-2 mm**

Adjustment:

- Push back the protective cap (2).
- Slacken the lock nut (3) on the handlebar.
- Turn the setscrew (4) accordingly.
- Tighten the lock nut (3).
- Check the play.
- Push over the protective cap (2).



NOTE

If the play cannot be corrected this way, have the scooter checked by your Sachs dealer.

NOTES ON MAINTENANCE

Cleaning the air filter

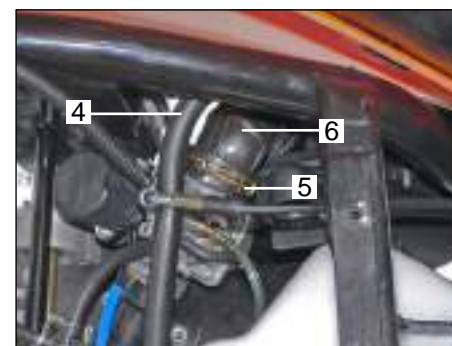

NOTE

The scooter is attached with a oil foam air filter. In case of heavy dirtiness the foam (11) has to be replaced.

- Remove the screws (2) and take off the storage box (3) together with the seat.

- Disconnect the hose (4) from the air filter housing.
- Remove the clamp (5) from the carburettor and disconnect the manifold (6).

Disassembly and cleaning

- Open the seat (1).

NOTES ON MAINTENANCE

Cleaning the air filter

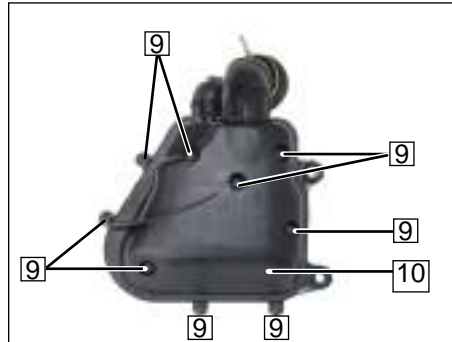
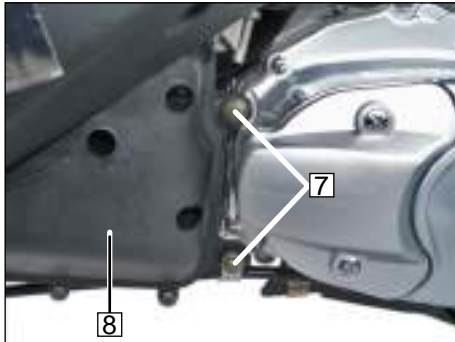

- Remove the screws (7) and take off the air filter housing (8).

Disassembly and cleaning

- Remove the screws (9) and take off the air filter cover (10).
- Remove the foam (11).
- Clean the foam with Motorrex air cleaner.
- Afterward soak and wring out the foam with air filter oil.

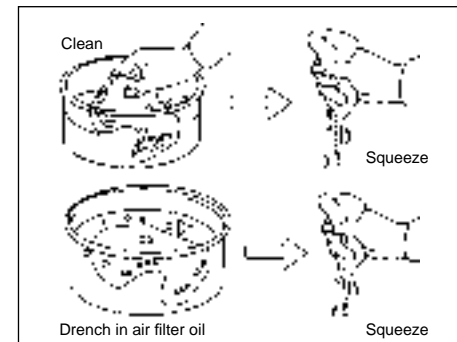

Cleaning the air filter



CAUTION

Never run the engine without air filter.

- Dust deposit is one of the major causes of reducing output horsepower and increasing fuel consumption.
- Change the air cleaner element more frequently to prolong the engine's service life if the scooter is ride on dusty roads very often.
- Check for properly installation of the foam housing in the filter case.
- Otherwise the engine runs poorly or lead to serious engine damage.
- Be careful not to soak the air cleaner when washing the scooter. Otherwise it will cause engine hard to start.



Installation



NOTE

Check the gasket (12) for damage and correct placement before installation.

The installation takes place in reverse order to disassembly.

NOTES ON MAINTENANCE

Checking the spark plug

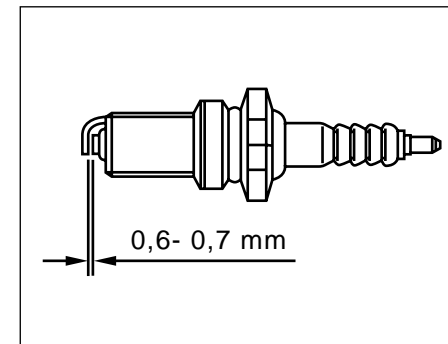

Check and change



CAUTION

Check or change the spark plug only when the engine is cold.



NOTE

The spark plug is accessible from the right-hand side.

- Pull the spark plug connector (1).
- Unscrew the spark plug with the spark wrench from the on-board toolkit.
- Check the electrode gap (0.6-0.7 mm), replace the spark plug if it is severely burnt away.
- Use a new spark plug **NGK BR7 ES** and tighten up.
- Screw in the spark plug by hand and then tighten up with the spark wrench.
- Plug in the spark plug connector (1).

Torque 11 Nm.

Checking the fuse

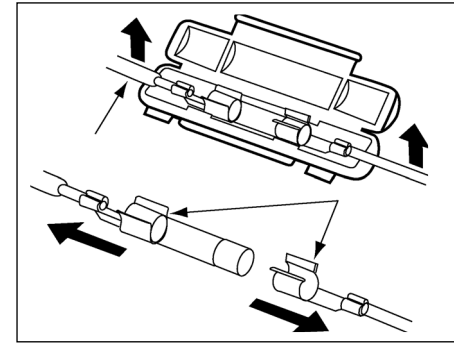

CAUTION
 Never install a fuse with a larger rating, since this could destroy the entire electrical system.

The fuse is located behind the inspection cover (2).

- Turn off the ignition.
- Remove the two screws (1) and open the inspection cover (2).
- Open the fuse case (3) and remove the fuse.
- A faulty or blown fuse must be replaced by a new one with 15 A.
- Check the fuse for correct contact. Loose fuse will blow.

Installation takes place in reverse order to disassembly.

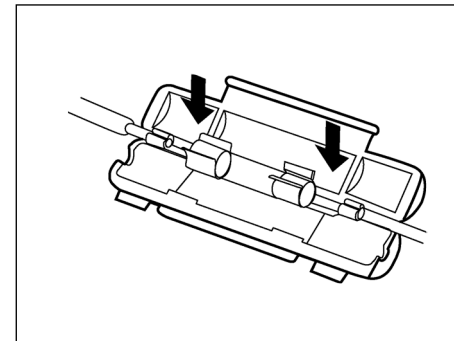

NOTES ON MAINTENANCE

Battery

 **WARNING**

Always wear safety glasses.
Keep children away from acids and batteries.

 **EXPLOSION DANGER**

A battery being charged produces a highly explosive gas, which is why fire, sparks, naked flames and smoking are prohibited.

 **FIRE HAZARD**

Avoid generating sparks and electrostatic discharges when handling cables and electrical devices.

Avoid short circuits.

 **DANGER - CAUSTIC ACTION**

Battery acid is highly caustic, so always wear safety gloves and glasses.
Do not tilt the battery as acid can leak from the ventilation openings.

 **FIRST AID**

If acid comes into contact with an eye, immediately flush the eye for several minutes with fresh water. Then immediately visit / call a doctor.

Acid on the skin or clothing must immediately be neutralised using acid converter or soap suds, and the spots must be flushed with plenty of water.

If acid is swallowed, immediately visit / call a doctor.

 **CAUTION**

Do not expose batteries to direct sunlight. Discharged batteries can freeze, so they must be stored in a place where the temperature remains above 5° - 15°C.

Professional maintenance, charging and storage will increase the lifespan of the battery and are a condition for the honouring of guarantee claims.

 **DISPOSAL**

Take a dead battery to a collection point. Never dispose of one with household refuse.

Charging the battery

After a long lay-up (3-4 months), charge the battery. The charging current (in amperes) must not exceed 1/10th of the battery capacity (Ah).

The battery must not be fast-charged. The battery may only be charged using a special charger approved for MF batteries.

Maintenance

Although the battery is maintenance-free. Never leave the battery discharged. Keep the battery clean and dry and make sure that the connection terminals are firmly seated.

Removing and installing the battery

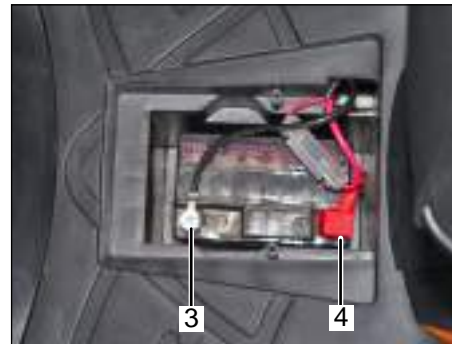

CAUTION
The battery may only be connected or disconnected while the ignition is inactive.

First disconnect the minus terminal (3, black cable).

When installing the battery, first connect the plus terminal (4, red cable).

The battery is maintenance-free. Do not try to open it.

- Turn off the ignition.
- Remove the two screws (1).
- Open the inspection cover (2).
- Disconnect the battery.
- Remove the battery.

Installation takes place in reverse order to disassembly.

NOTES ON MAINTENANCE

Headlight and position light

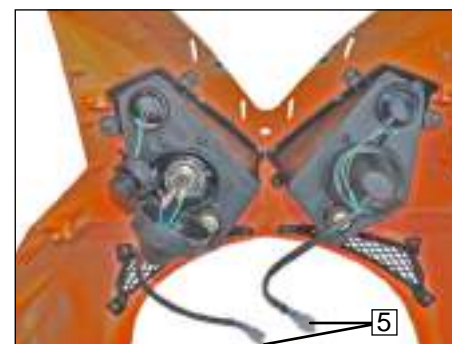
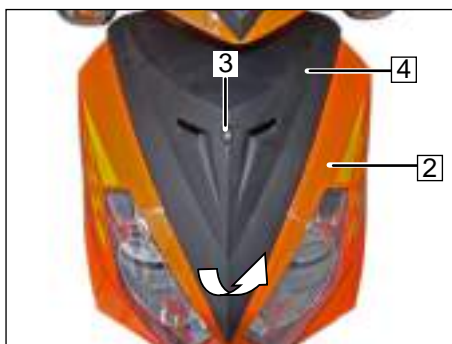

Changing the bulb



NOTE

Use only tested, incandescent bulbs with the 'E' designation. Use of non-approved bulbs will void the operating license. Do not touch the bulbs with bare fingers. Hold bulbs with a clean, dry cloth when installing or removing them.

Low beam - high beam

bulb: 12V 15W

Position light

bulb: 12V/5W

- Turn off the ignition.
- Remove the covering screws (1).
- Remove the screw (3) and take off the front cover (4).

- Disconnect the plugs (5).
- Take off the headlight cover (2).

Headlight and position light

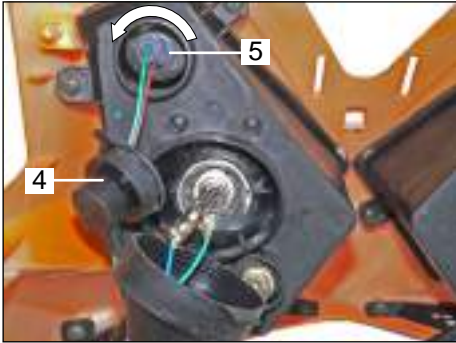
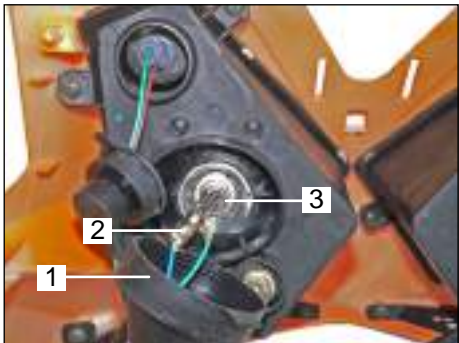

Low beam

- Remove the rubber cover (1).
- Disconnect the holder clamp (2).
- Remove the head light bulb (3)

Installation takes place in reverse order to disassembly.

Position light

- Remove the rubber cover (4).
- Pull the position light (5) with the bulb holder by turning carefully to the left out of the headlight housing.

Installation takes place in reverse order to disassembly.



NOTE

During installation make sure that the terminals of the headlight cover (2) and of the front cover (4) and are firmly pushed in the guides.

Installation takes place in reverse order to disassembly.

NOTES ON MAINTENANCE

Front and rear indicator

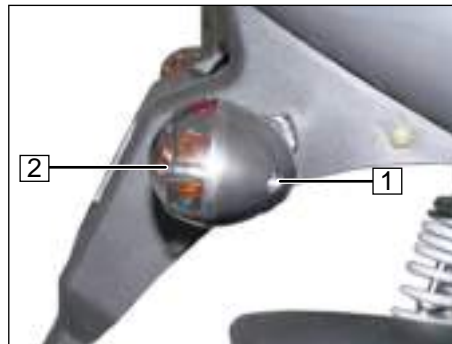
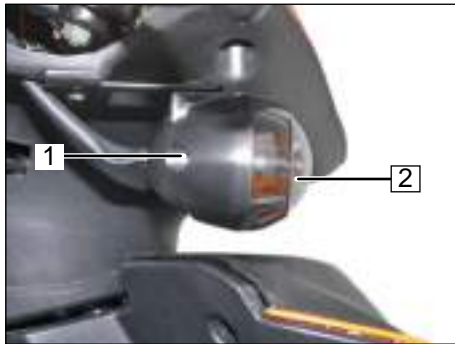

Changing the bulbs



NOTE

Do not touch the bulbs with bare fingers. Hold bulbs with a clean, dry cloth when installing or removing them.

- Remove the screws (1).
- Carefully remove the cover (2).

- Remove the bulb socket (3) and release it by turning to the left.
- Remove the bulb.

Installation takes place in reverse order to disassembly.

bulbs: **12V 10W**

Tail / brake light



Changing the bulb



NOTE

Do not touch the bulb with bare fingers. Hold bulbs with a clean, dry cloth when installing or removing them.

- Remove the screws (1).
- Carefully remove the tail / brake light cover (2).

- Push the bulb (3) back and release it by turning to the left.

- Remove the bulbs.

Installation takes place in reverse order to disassembly.

Tail / brake light
bulb: **12V 21/5W**

NOTES ON MAINTENANCE

Check the headlamps

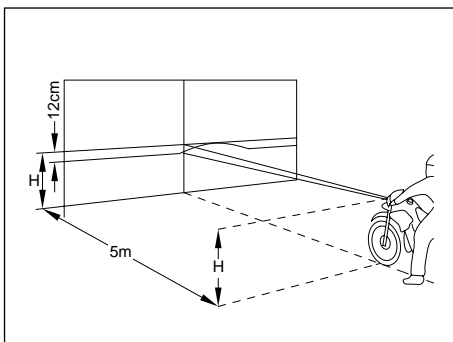

⚠ WARNING
Do not run the engine in an enclosed space (risk of asphyxiation).

Position the motorcycle on a level floor 5 m (measured from the headlamp) from a light coloured wall with a rider seated on the motorcycle and the tyres filled at the correct pressure.

- Measure the distance from the floor to the centre of the headlamp and mark the height on the wall with a cross. Draw a second cross 12 cm beneath the first cross.

Adjusting the headlamps

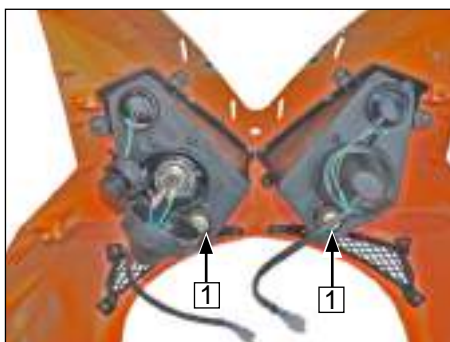

- Start the motorcycle and run the engine.
- Activate the dipped beam.
- Use a screwdriver to adjust the screws (1) for the vertical and horizontal angle of the illuminated surface area of the road top for the left and right headlamp.



👉 NOTE
If you have problems adjusting the headlamps, see a specialised Sachs dealer. An incorrect adjustment is punishable by law. Remember, you are responsible for the correct adjustment of the motorbike's headlamp.

TECHNICAL DATA

Speedforce 50	
Engine type	LJ1PE40QMB
Construction:	One cylinder 2-stroke petrol engine
Piston displacement:	49 cm ³
Bore:	ø 40 mm
Stroke:	39.2 mm
Compression ratio:	6.5:1
Cooling:	Fan air cooled
Maximum net power output:	2.1 kW at 8.000 1/min
Maximum net torque:	3.2 Nm at 5.500 1/min
Ignition system:	Transistorized ignition system with electronic ignition control (CDI)
Spark plug:	NGK BR7 ES
Electrode gap:	0.6 - 0.7 mm
Carburettor:	JK type 16P-6F
Idle speed:	1.800 +/- 180 1/min
Air-filter:	Foam air-cleaner
Typ of starter:	Electric starter and kick starter

TECHNICAL DATA

Speedforce 50	
Power transmission	
Clutch:	Centrifugal type
Transmission:	CVT
Chassis	
Scooter version:	LJ50QT-K
Front suspension:	Telescopic fork
Rear suspension:	Unit swing, hydraulic shock absorption, adjustable preload
Wheels front:	Light metal (Alu) MT 2.50 x 12
Wheels rear:	Light metal (Alu) MT 2.50 x 12
Tires front:	120/70-12 56J tubeless
Tires rear:	130/70-12 56J tubeless
Tire pressure:	front = 2.0 bar rear = 2.25 bar
Brakes, front:	Disc brake ø 190 mm, hydraulic
Brakes, rear:	Drum ø 110 mm, mechanical

TECHNICAL DATA

Speedforce 50	
Lubricants and operating fluids	
Fuel tank capacity:	4.7 Liter
Fuel:	Premium lead-free fuel (min. 95 octane)
Lubricating oil:	Mineral - or semi-synthetic oil for separate injection API-Norm TC, JASO-Norm FC
Transmission oil: Filling quantity:	Hypoid-oil SAE 85W - 140 or SAE 80W-90 GL5 oil change: 0.10 litres / oil change + overhaul: 0.11 litres
Electrical Equipment	
Generator:	12V 130W
Battery:	12V 6Ah MF
Fuse:	15 A
Head light:	Low beam 12V 15W
Position light:	12V 5W
Instrument lights	
Speedometer:	12V 1.7W
Control lights indicator and high beam:	12V 1.7W
Brake/rear light:	12V 21/5W
Turn signal light:	4 x 12V 10W

TECHNICAL DATA

Speedforce 50	
Dimensions and weights	
Overall length:	1830 mm
Width across handlebars:	705 mm without rear view mirror
Maximum height:	1165 mm without rear view mirror
Wheel base:	1290 mm
Seat height:	800 mm
Weight empty:	87 kg
Weight in running order:	92 kg
Max. permitted total weight:	247 kg
Top speed:	45 km/h

Warranty conditions

In case of an occurring fault the company Sachs Fahrzeug- und Motorentechnik GmbH will provide the customer with the following performances through the authorized Sachs-dealer (seller) within the scope of its statutory warranty obligations:

1. Within a period of 24 months after the delivery of the motorbike to the end customer the company Sachs Fahrzeug- und Motorentechnik GmbH will rectify any deficiencies caused by material or manufacturing faults through the authorized Sachs-dealer (seller) by repairing or replacing the affected part according to the statutory warranty regulations. Sachs Fahrzeug- und Motorentechnik GmbH may deny the requested repair or replacement of the faulty part if this would only be possible with disproportionately high costs. In this case Sachs Fahrzeug- und Motorentechnik GmbH may rectify the deficiency through the authorized Sachs-dealer (seller) by applying the other possible type of subsequent fulfillment. If both types of subsequent fulfillment are only possible with unproportionately high costs, Sachs Fahrzeug- und Motorentechnik GmbH may deny the subsequent fulfillment altogether through the authorized Sachs-dealer (seller). The customer is then entitled to legal claims. Replaced parts pass over into the possession of Sachs Fahrzeug- und Motorentechnik GmbH.
2. The installation of spare parts within the scope of warranty does not extend the warranty period that has started with the date of delivery of the motorcycle.
3. The warranty does not cover normal wear and tear caused by normal use as well as wear and tear caused by inappropriate handling and inappropriate use. Oxidation and corrosion are caused by environmental influences and are also not covered under warranty
4. Warranty claims lodged by the customer will be rejected in case of: Manipulations to the motorcycle, installation of a different exhaust system, changes to the gearbox or secondary transmission ratio and installation of accessories or spare parts which have not been approved by Sachs Fahrzeugtechnik. Repairs carried out in workshops not authorized by Sachs Fahrzeug- und Motorentechnik GmbH and the non-compliance with the maintenance intervals in the workshop of an authorized Sachs-dealer will also cause the rejection of warranty claims.
5. When lodging a warranty claim the customer must present the correctly filled in service book to the seller.
6. The following table gives the customer an overview of the average limits of the respective wear parts:

WARRANTY

List of wear parts

Wear parts	Wear limits
Tires, hoses, rims	depending on riding style, load and tire pressure the wear limit may already be reached after only 500 km or even earlier.
Wheels, hubs	depending on riding style, load and tire pressure the wear limit may already be reached after only 1500 km or even earlier. Check during each maintenance. Oxidation is a lack of maintenance!
Oils, air filter, leakage inspection on engine	during the first inspection, then with every maintenance interval (every 3000 km / 6000 km). Check oil level before every ride.
Spring fork, spring strut	Cleaning / inspection during every maintenance.
Lamps, incandescent bulbs, electric system	depending on road conditions / unevenness of the road surface the lifetime will be reduced, this may already occur after 500 km.
Brake linings, brake shoes, brake lines	depending on riding style and load these may already be worn after 1500 km, in cross-country operation even earlier.
Sedal rings, sealants, O-rings	must be replaced during each maintenance interval to ensure proper function.
Radial seals on engine, gearbox, fork and wheels	depending on road conditions and care wear may start after 500 km. Dirt reduces the lifetime. Do not clean with a high pressure cleaner!
Wheel bearings, steering bearings	depending on road conditions and care wear may start after 1500 km. Soiling of the wheel hub reduces the lifetime. Check during each maintenance interval, do not clean with a high pressure cleaner!
Swing arm bearing	depending on load and care after 1500 km, check with every maintenance.
Cables	depending on care starting after 500 km. Check with every maintenance.
Coverings	Plastic parts will be damaged by caustic or penetrating cleaning agents or solvents.

WARRANTY

List of wear parts

Wear parts	Wear limits
Air cleaner	with each maintenance interval.
Starter battery, batteries, fuses, starter brushes	depending on ambient temperatures failures can be expected in the 6th month, when used for short rides even earlier.
Mirror glasses	depending on ambient temperatures and care failures can be expected in the 6th month, in winter operation even earlier. Oxidation is a lack of maintenance!
Bowden cables, brake cables, throttle cables	depending on use and care from the 6th month.
Self-locking nuts, cotter pins locking plates bonded screw connections	during each maintenance interval or after unscrewing the nut or unlocking the lock.
Variomatic, CVT, rolls, belts	depending on riding style and load these may be worn after 500 km.
Clutch linings / friction discs	depending on riding style and load these may be worn after 500 km.
Pistons, cylinders, crankshaft, conrods, engine bearings	depending on riding style, load and care these parts may be worn after 200 hours. When riding mainly with full throttle even earlier.
Spark plug	with each or every second maintenance interval.
Exhaust system, inspection of mountings	depending on use and care from the 6th month, in winter and short distance operation even earlier. Oxidation is a lack of maintenance!

INSPECTION PLAN

Please observe the following:

- During and after the warranty period all inspections should solely be performed by a specialised dealer approved by us.
- Observe the inspection intervals and have the specialised dealer confirm them on the guarantee certificate.
- Use only original spare parts.



CAUTION

In case of non-compliance the warranty will become null and void.

The various activities carried out are listed on the inspection plan.

During the warranty period the following inspection intervals must be complied with:

At	1.000 km (1 st service)
Every	3.000 km / or after 6 months
Every	6.000 km / or after 12 months

After the warranty period the inspection intervals specified in this manual must be applied as follows:

Every	3.000 km / 6 months
Every	6.000 km / 12 months



WARNING

For safety reasons, do not carry out any repair or adjustment activities to the motorcycle and chassis that exceed a closely restricted scope. Tinkering with safety-relevant parts could threaten the safety of yourself and third parties.

This applies especially to the exhaust system, carburettor, ignition system, fork column, brake system and lights.

Before starting work on the electrical system, disconnect the minus terminal of the battery.

INSPECTION PLAN

I = Inspection, cleaning, and adjustment R = Replacement C = Cleaning (replaced if necessary) L = Lubrication					
Component Assembly	Before each trip	1st service after 1000 km	Every 3.000 km / 6 months	Every 6.000 km / 12 months	Every 12.000 km / 24 months
Air cleaner (foam filter)	I	I	C		R
Fuel filter	I	I	I		R
Spark plug	I	I	I		R
Ignition time		I	I		
Carburettor (Idle speed)	I	I	I		
Throttle cable adjustment	I	I	I		
Transmission oil	I	R	I	R	
Transmission check for leakage	I	I	I		
Crankcase check for leakage	I	I	I		
Crankcase ventilation		I	I		
Drive belt, roller			I	I / R	
Clutch discs			I	I / R	

INSPECTION PLAN

I = Inspection, cleaning, and adjustment R = Replacement C = Cleaning (replaced if necessary) L = Lubrication					
Component Assembly	Before each trip	1st service after 1000 km	Every 3.000 km / 6 months	Every 6.000 km / 12 months	Every 12.000 km / 24 months
Bolts and nuts (engine)	I	I	I		
Exhaust system		I	I		
Fuel tank, fuel hoses	I	I	I		
Battery	I	I	I		
Steering and bearings	I	I	I		
Front and rear suspension	I	I		I	
shock absorption	I	I		I	
Tire pressure	I	I	I		
Brake function, brake pads	I	I	I		
Brake fluid	I	I	I		R / every 2 years
Main- and side stand	I	I	I / L		
Bolts and nuts (chassis)	I	I	I		

MAINTENANCE CONFIRMATION

<p>1.000 km / 1 months 1st service dealer stamp:</p> <p>km</p> <p>date</p>	<p>After 3.000 km / 6 months dealer stamp:</p> <p>km</p> <p>date</p>	<p>After 6.000 km / 12 months dealer stamp:</p> <p>km</p> <p>date</p>	<p>After 9.000 km / 18 months dealer stamp:</p> <p>km</p> <p>date</p>
<p>After 12.000 km / 24 months dealer stamp:</p> <p>km</p> <p>date</p>	<p>After 15.000 km / 30 months dealer stamp:</p> <p>km</p> <p>date</p>	<p>After 18.000 km / 36 months dealer stamp:</p> <p>km</p> <p>date</p>	<p>After 21.000 km / 42 months dealer stamp:</p> <p>km</p> <p>date</p>

MAINTENANCE CONFIRMATION

New brake fluid
Yes no

Km.....
Date

Stamp, signature

New brake fluid
Yes no

Km.....
Date

Stamp, signature

New brake fluid
Yes no

Km.....
Date

Stamp, signature

New brake fluid
Yes no

Km.....
Date

Stamp, signature