

**M2-50-125-150**  
**SERVICE MANUAL**

**G-MAX<sub>50</sub>**

**G-MAX<sub>125</sub>**

**G-MAX<sub>150</sub>**

**Manufactured by PGO**  
**of Motive Power Industry Co., Ltd**

## **PREFACE**

This manual provides every service specialist with professional techniques of maintenance and repairing for G-MAX . It provides a detailed guide for those who may concern with how to maintain, repair, reassemble, and change parts of their scooters.

This manual includes 3 kinds of engine displacement:

- G-MAX 50: abbreviated as “M2-50” is 2 stroke engine (2T), 50cc displacement.
- G-MAX 125 : abbreviated as “M2-125” is 4 stroke engine (4T), 125cc displacement.
- G-MAX 150: abbreviated as “M2-150” is 4 stroke engine (4T), 150cc displacement.

At every section, we illustrate each important point by assembling procedures, explosive diagrams and photographs.

Although we have tried our best to make this manual as perfect as possible, please kindly inform us if any fault needs to be corrected in this manual.

Thank you for purchasing our PGO scooters.

Motive Power Industry Co.,Ltd.  
Service Department  
17<sup>th</sup> January, 2005

# CONTENTS :

Page

- . The specification of G-MAX
- . Service information
- (1) The operation notice
- (2) Locking torque value
- (3) Lubrication instruction
- (4) Periodical maintenance table
- (5) Troubleshooting
- . Checking and adjustment
- (1) Regular checking table
- (2) Battery
- (3) Cleaning air cleaner
- (4) The final reduction mechanism oil
- (5) Spark plug
- (6) Compression pressure measurement
- (7) Ignition timing
- (8) Throttle cables adjustment
- (9) Idle adjustment
- (10) Front brake adjustment
- (11) Rear brake adjustment
- (12) Tire
- . Dismantling, maintaining, repairing and assembling operation
- (1) Plastic parts
- (2) G-MAX 50 Engine dismantling
  - A. Lubrication system
  - B. Drive pulley, starter, clutch
  - C. Cylinder and piston
  - D. AC generator
  - E. Final transmission mechanism
  - F. Crankcase, crank shaft
  - G. Carburetor, reed valve
- (3) G-MAX 125/150 Engine dismantling
  - A. Lubrication system
  - B. Drive pulley, starter, clutch
  - C. Cylinder and piston
  - D. AC generator
  - E. Final transmission mechanism
  - F. Crankcase, crank shaft

## G. Carburetor

- (4) Engine & chassis suspension
- (5) Steering column, front wheel, front brake comp, front fork
- (6) Rear wheel, rear brake, rear damper
- (7) Fuel tank, oil tank
- (8) Reverse Differential gear comp

## .Electric equipment

- (1) Troubleshooting
- (2) Battery
- (3) Recharge system
- (4) Ignition system
- (5) Starting system
- (6) Switch operation
- (7) Wiring diagram



## 1.1 G-MAX 50

SPECIFICATION							
BRAND		PGO		FRAME		STEEL PIPE	
MODEL		M2-50D		SUSP ENSI ON	FRONT	TELESCOPE	
DIMENSION	LENGTH		1855 mm		REAR	SWING	
	WIDTH		730 mm		TRANSMISSI	PRIMARY	DIRECT
	HEIGHT		1170 mm			2ND	52/13*44/13
	AXLE DISTANCE		1365 mm			CLUTCH	CENTRIGUAL
						SHIFTING	V-BELT C.V.T
WEIGHT	GROSS	FRONT	47 KG		TIRE	FRONT	120/70-12
		REAR	58 KG			REAR	130/70-12
		TOTAL	105 KG				
	PASSENGER		2 (110KG)		BRA KE	FRONT	DISK
	TOTAL	FRONT	82 KG			REAR	DRUM
		REAR	133 KG		SPEEDOMETER		80 km/hr
		TOTAL	215 KG		LIGGHT	HEAD(HI, LO)	12V-35W/35W
TOP SPEED		60 km/hr		REAR		12V-5W	
FUEL CONSUMPTION		45 km/l		BRAKE		12V-21W	
GRADIENT		19°		SIGNAL		12V-10W*4	
ENGINE	ENGINE MODEL		P2		HORN		DC 12V
	FUEL		92 UNLEADED		SILENCER		DIFFUSER
	STROKE		2T AIR FORCED		EXHAUS	PARTICLE	BELOW 15 %
	CYLINDE	BORE	40.0 mm			CO	BELOW 4.5%
		STROKE	39.2 mm			HC	BELOW 7000 ppm
	CYLINDER		SINGLE		EXHAUST LAYOUT		RIGHT
	DISPLACEMENT		49 cc		LUBRICATE		SEPARATE PUMP
	C.R.		6.8 : 1		FUEL TANK		7.5 L
	MAX H.P.		3.5kw/7000rpm				
	MAX TORQUE		5.0N-M/6500rpm				
	LAYOUR		HORIZONTAL				
	IGNITION		CDI				
	STARTING		ELECTRIC & KICK				

## 1.2 G-MAX 125

SPECIFICATION							
BRAND		PGO		FRAME		STEEL PIPE	
MODEL		M2-50D		SUSP ENSI ON	FRONT	TELESCOPE	
DIMENSION	LENGTH		1855 mm		REAR	SWING	
	WIDTH		730 mm		TRANSMISSI	PRIMARY	DIRECT
	HEIGHT		1170 mm			2ND	43/14*42/13
	AXLE DISTANCE		1365 mm			CLUTCH	CENTRIGUAL
						SHIFTING	V-BELT C.V.T
WEIGHT	GROSS	FRONT	54 KG		TIRE	FRONT	120/70-13
		REAR	76 KG			REAR	130/70-13
		TOTAL	130 KG				
	PASSENGER		2 (110KG)		BRA KE	FRONT	DISK
	TOTAL	FRONT	94 KG			REAR	DISK
		REAR	146 KG		SPEEDOMETER		140 km/hr
		TOTAL	230 KG		LIGGHT	HEAD(HI, LO)	12V-35W/35W
TOP SPEED		84 km/hr		REAR		12V-5W	
FUEL CONSUMPTION		40 km/l		BRAKE		12V-21W	
GRADIENT		21°		SIGNAL		12V-10W*4	
ENGINE	ENGINE MODEL		C1M		HORN		DC 12V
	FUEL		92 UNLEADED		SILENCER		DIFFUSER
	STROKE		4T AIR FORCED		EXHAUS	PARTICLE	BELOW 15 %
	CYLINDE	BORE	51.5 mm			CO	BELOW 4.5%
		STROKE	60.0 mm			HC	BELOW 7000 ppm
	CYLINDER		SINGLE		EXHAUST LAYOUT		RIGHT
	DISPLACEMENT		124.9 cc		LUBRICATE		SEPARATE PUMP & SPLASH
	C.R.		9.2 : 1		FUEL TANK		
	MAX H.P.		6.5kw/7500rpm				
	MAX TORQUE		9.1N-M/6250rpm				
	LAYOUR		HORIZONTAL				
	IGNITION		CDI				
	STARTING		ELECTRIC & KICK				

### 1.3 G-MAX 150

SPECIFICATION							
BRAND		PGO		FRAME		STEEL PIPE	
MODEL		M2-150		SUSP ENSI ON	FRONT	TELESCOPE	
DIMENSION	LENGTH		1855 mm		REAR	SWING	
	WIDTH		730 mm		TRANSMISSI	PRIMARY	DIRECT
	HEIGHT		1170 mm			2ND	42/15*42/13
	AXLE DISTANCE		1365 mm			CLUTCH	CENTRIGUAL
	WEIGHT	GROSS	FRONT	55 KG		SHIFTING	
REAR			77 KG		TIRE	FRONT	120/70-13
TOTAL			132 KG			REAR	130/70-13
PASSENGER		2 (110KG)		BRA KE	FRONT	DISK	
TOTAL		FRONT	95 KG		REAR	DISK	
		REAR	147 KG		SPEEDOMETER		1400 km/hr
		TOTAL	242 KG		LIGGHT	HEAD(HI, LO)	12V-35W/35W
TOP SPEED		87 km/hr		REAR		12V-5W	
FUEL CONSUMPTION		40 km/l		BRAKE		12V-21W	
GRADIENT		24°		SIGNAL		12V-10W*4	
ENGINE	ENGINE MODEL		C5M		HORN		DC 12V
	FUEL		92 UNLEADED		SILENCER		DIFFUSER
	STROKE		4T AIR FORCED		EXHAUS	PARTICLE	BELOW 15 %
	CYLINDE	BORE	57.0 mm			CO	BELOW 4.5%
		STROKE	57.8 mm			HC	BELOW 7000 ppm
	CYLINDER		SINGLE		EXHAUST LAYOUT		RIGHT
	DISPLACEMENT		147.5 cc		LUBRICATE		SEPARATE PUMP & SPLASH
	C.R.		9.4 : 1		FUEL TANK		
	MAX H.P.		7.7kw/7250rpm				
	MAX TORQUE		10.6N-M/6250rpm				
	LAYOUR		HORIZONTAL				
	IGNITION		CDI				
STARTING		ELECTRIC & KICK					

## .Service information :

- (1)The operation notice
- (2)Locking torque value
  - 1.For engine
  2. For chassis
  3. Others
- (3) Lubrication instruction
  - a.For engine
  - b. For chassis
  - c. Wheel bearing
- (4)Wiring diagram
- (5)Troubleshooting
  - 1.Difficult starting or starting
  - 2.Weak acceleration
  - 3.Engine running not smoothly (low speed)
  - 4.Engine running not smoothly(high speed)
  - 5.Clutch, drive & driven pulley
  - 6.Handlebar steering was astray when running
  - 7.Front and rear damper not balanced
  - 8.Brake disorder
  - 9.Oil indicator malfunction
  10. Fuel indicator malfunction
  11. Starting motor malfunction
  - 12.No sparking
  - 13.Charging abnormal

**(1)The operation notice :**

- 1.For parts like the gasket, o-ring, clips and circlets, please change a new part whenever re-assembled.
- 2.When trying to tighten screws or nuts, please lock tightly according to each recommended locking torque and in the sequence of the "X" pattern.
- 3.Please use PGO or PGO recommended parts.
- 4.After dismantling, please clean all parts involved or used for checking and grease all contact surfaces when reassembling.
- 5.Use grease recommended by P.G.O.
- 6.When removing the battery, please disconnect the negative pole(-) first. However, please connect the positive pole(+) first when assembling.
- 7.Before installing a new fuse, please be sure that the specification is correct.
- 8.After reassembling, please re-confirm that all connecting point, locking parts, circuits, polar characteristics are functioning well before selling out.

**(2) Locking Torque Value:**

**1. 2T Engine (50CC)**

<b>No</b>	<b>Locking location</b>	<b>Thread Dia (mm)</b>	<b>Locking torque kg-m</b>	<b>Remarks</b>
1	Cylinder head	7	1.0~1.4	When the engine is cold
2	Flywheel outer	10	3.2~4.0	
3	Rear brake lever	6	1.0~1.2	
4	Driving pulley	10	3.2~4.0	
5	Clutch outer	10	3.5~4.0	
6	Right crankcase	6	1.0~1.2	
7	Drive gear box cover	6	1.0~1.2	
8	Left crankcase	6	1.0~1.2	
9	Draining and filler bolt	8	1.8	When the engine is cold
10	Inlet pipe	6	1.0~1.2	
11	Flywheel magneto stator	6	1.0~1.2	
12	Cooling fan	6	1.0~1.2	
13	Muffler nut on cylinder head	6	1.0~1.2	When the engine is cold
14	Starting motor	6	1.0~1.4	When the engine is cold
15	Bracket between eng. and Rubber pad of central stand	6	1.0~1.2	
16	Spark plug	14	2.5~3.0	
17	Fan cover	6	1.0~1.2	
18	Fixed plate, drive clutch	6	1.0~1.4	
19	Nut of rear wheel axle	14	11~13	U TYPE NUT
20	Kick starter	6	1.0~1.2	

## 2. 4T Engine (125/150 CC)

<b>NO</b>	<b>Locking location</b>	<b>Q'ty</b>	<b>Thread dia. (mm)</b>	<b>Locking torque (kg-m)</b>
1	Fixing nut (Tappet screw nut)	2	5	0.7~0.8
2	Nut of oil pump sprocket	1	6	0.7~1.0
3	Cylinder head bolt A (intake)	2	6	0.9~1.1
4	Guiding pin bolt, chain extensioner	1	6	0.4~0.6
5	Screw, chain extensioner	2	6	0.9~1.1
6	Cylinder head bolt B (Exhaust)	2	8	2.0~2.3
7	Flange nut, cam shaft holder	4	8	2.0~2.3
8	Gear oil drain bolt	1	8	1.7~2.0
9	Spark plug	1	10	1.2~1.3
10	Nut of fly wheel	1	12	5.0~6.0
11	Fixing nut, clutch outer	1	12	5.0~6.0
12	Nut, driving plate	1	12	5.0~6.0
13	Bolt of engine oil drain	1	12	2.5~3.0
14	Bolt of 2 <sup>nd</sup> oil filter	1	12	0.8
15	Nut (LH thread), one-way clutch	1	22	9.0~10.0
16	Cap, coarse oil filter	1	30	1.5~2.0

### 3. Chassis

NO	Locking location	Q'TY	Thread dia. (mm)	Locking torque (kg-m)
1	Air bleed bolt of caliper	1	6	0.6
2	Brake arm bolt, front drum	1	6	0.8~1.0
3	Brake arm bolt , rear drum	1	6	0.8~1.0
4	Nut of starter relay	2	6	0.5~0.6
5	Front brake caliper bolt	2	8	2.0 ~ 3.0
6	Bolt of disk	3	8	2.5~3.0
7	Locking nut, steering stem	1	10	3.5~4.5
8	Rear shock absorber bolt(lower)	1	10	3.5 ~ 4.5
9	Rear shock absorber bolt(upper)	1	10	3.5~4.5
10	Chassis bolt, engine hanger bracket	2	10	4.5 ~ 5.0
11	Engine bolt, engine hanger bracket	1	10	3.0 ~ 4.0
12	Hose bolt, master cyl. & caliper	2	10	2.5 ~ 3.0
13	Front axle nut	1	12	4.5 ~ 5.5
14	Nut, swing arm & connecting rod	1	14	4.5 ~ 5.5
14	Rear axle nut	1	16	10.0~11.0

### 4. Other parts standard torque values:

No	Item	Torque kg-m
1	5mm bolt and nut	0.45-0.6
2	6mm bolt and nut	0.8-1.2
3	8mm bolt and nut	1.8-2.5
4	10mm bolt and nut	3.0-4.0
5	12mm bolt and nut	5.0-6.0
6	5mm screw	0.35-0.5
7	6mm screw	0.7-1.4
8	6mm flange bolt and screw	1.0-1.4
9	7mm flange bolt and screw	1.0-1.4
10	8mm flange bolt and screw	2.0-3.0
11	10mm flange bolt and screw	3.0-4.0



### (3)Lubrication instruction

#### A. 2T Engine (50 cc)

NO	Lubrication location	Oil type	Remarks
1	Crankcase: rotating part, Sliding part	Premium 2 stroke Motorcycle oil Or SAE#30	Separated-pump Lubrication
2	Cylinder: rotating part, Sliding part.		
3	Drive gear box	SAE85-140	Total 110 c.c. Replacement 90c.c
4	Gasket of starter shaft	Clean grease	(#3)
5	Start idle gear sliding parts	Clean grease	(#3)

#### B. 4T Engine (125/150 cc)

NO	Lubrication location	Oil type	Remarks
1	Crankcase: rotating part, Sliding part	premium 4 stroke  motorcycle oil  or SAE15W40	Auto-Separated Lubrication
2	Cylinder: rotating part, Sliding part.		
3	Drive gear box	SAE85-140	Total 110 c.c. Replacement 90c.c
4	Gasket of starter shaft	Clean grease	(#3)
5	Start idle gear sliding parts	Clean grease	(#3)

## C. Chassis appearance

1. Apply oil : #1, #2

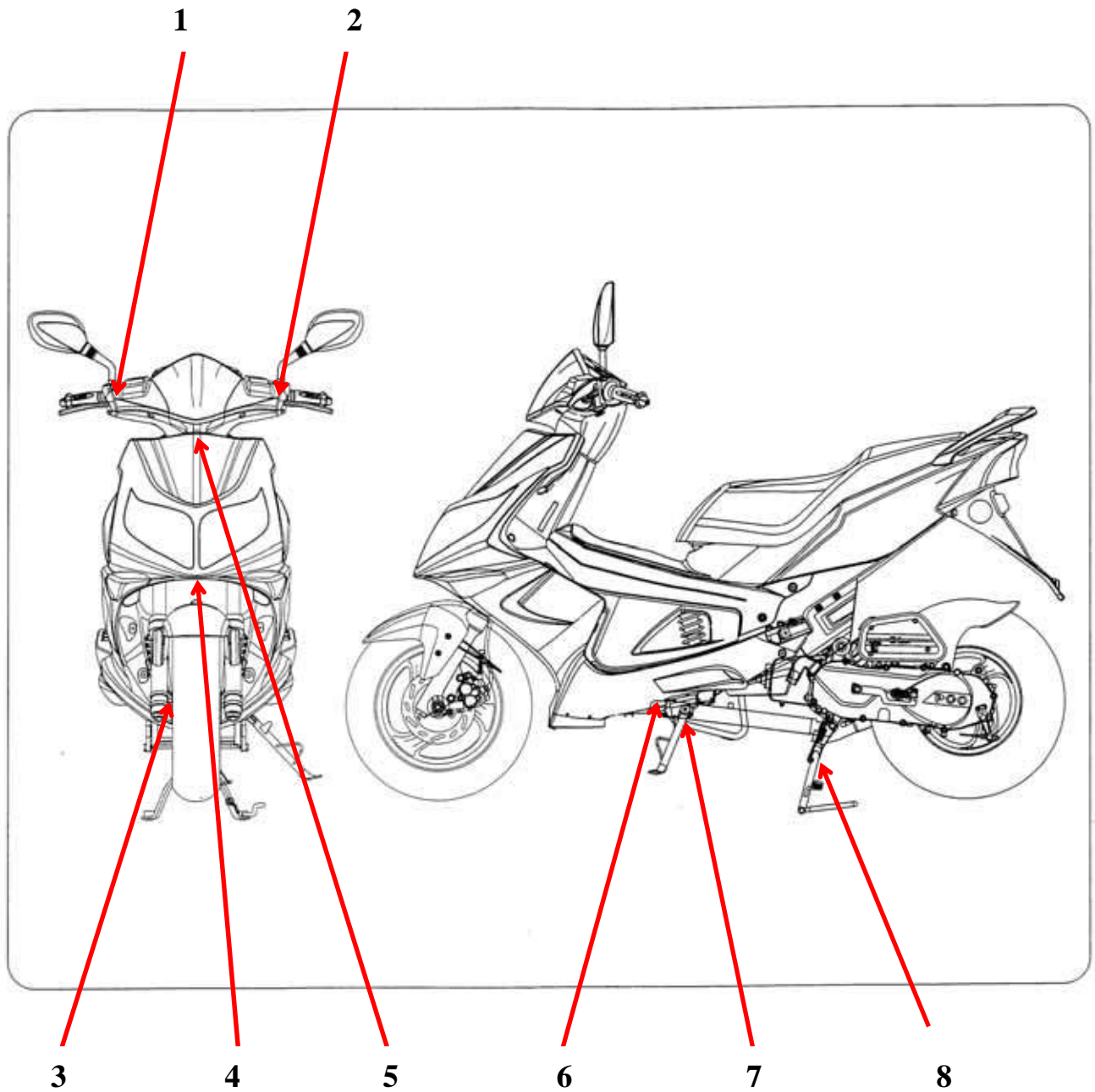

2. Apply grease (#3, #4, #5. #6 ,#7, #8)

D. Wheel bearing

**Final transmission mechanism gear oil**



錯誤!

**Speedometer gear: clean grease**



#### (4)PERIODICAL MAINTENANCE TABLE

Item	Model 2T or 4T	Checking Content	MONTHS/DISTANCE(IN KM)FOR CHECKING					
			1 or 300 km	3 or 3000k	6 or 5000k	9 or 8000k	12 or 10000k	15 or 13000k
Engine oil	2T	Add	According to Oil warning light					
Engine oil*	4T	Replace (800cc, total 900cc)	Replace it per 1000km					
Oil Filter	ALL	Replace	Clean it per 5000km or replace it if required					
Coarse oil filter* (on oil draining bolt)	4T	Clean or replace it if necessary	Clean it per 3000km or replace it if required					
Air cleaner	ALL	Clean or replace it if necessary						
Air filter	ALL	Clean or replace it if required						
Gear oil*	ALL	Replace (90cc, total 110 cc)						
Disk & drum brake	ALL	Leaking and function check						
Clutch shoes*	ALL	Check or replace it if necessary						
Rear brake arm	ALL	Function check and adjustment						
Tires	ALL	Worn-out check or replace it if necessary						
Wheel bearing*	ALL	Fasten tightly if loosen						
Front fork*	ALL	Leaking and function check						
Steering head bearing*	ALL	Check looseness. Adjust it if required						
Rear absorber*	ALL	Leaking and function check						
Main/Side Stand	ALL	Function check or replace it if required						
Nuts, bolts, fasteners	ALL	Tighten it if required						
Battery	ALL	Make sure that the voltage stayed over 12.8V. Recharge the battery it required. Clear the poles.						
Valve gap*	4T	Check and adjust when engine is cool (0.08mm for IN & EX)	Adjust it when necessary					
Carbon cleaning *	2T	Clean combustion carbon when engine output reduced						
Spark plug*	ALL	Clear or replace if required						
V belt*	ALL	Worn out check or replace if necessary.				A		A
Fuel feeding system*	ALL	Crack and blockage check. Replace it if necessary.						
Engine idle speed*	ALL	2T engine: 1900±100 rpm 4T engine: 1700±100 rpm						
Carburetor idle A/F Adjustment*	ALL	Check and adjust referring to CO/HC Percentage.						

#### NOTE :

1. Items with “\*” mark indicate our recommendation to have it done by PGO dealer.
2. “A” denotes that function check or replace it when the engine performance reduces significantly.
3. For 4T engine, the engine oil shall be changed completely after run-in period 300km or one month later. This can make sure the engine runs smoothly.

## (5) Trouble shooting:

1. difficult starting or can't start:

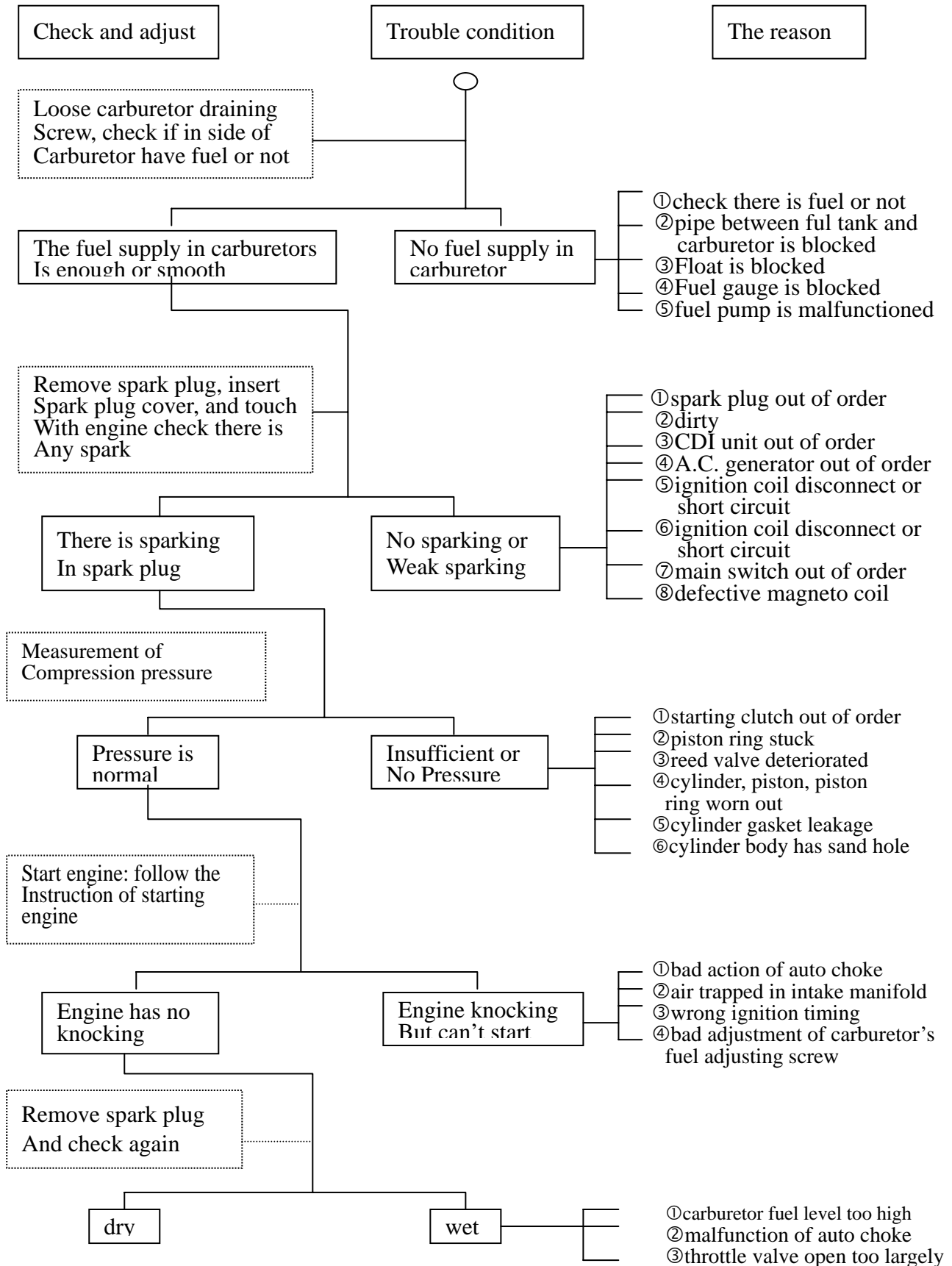

2. Weak acceleration:

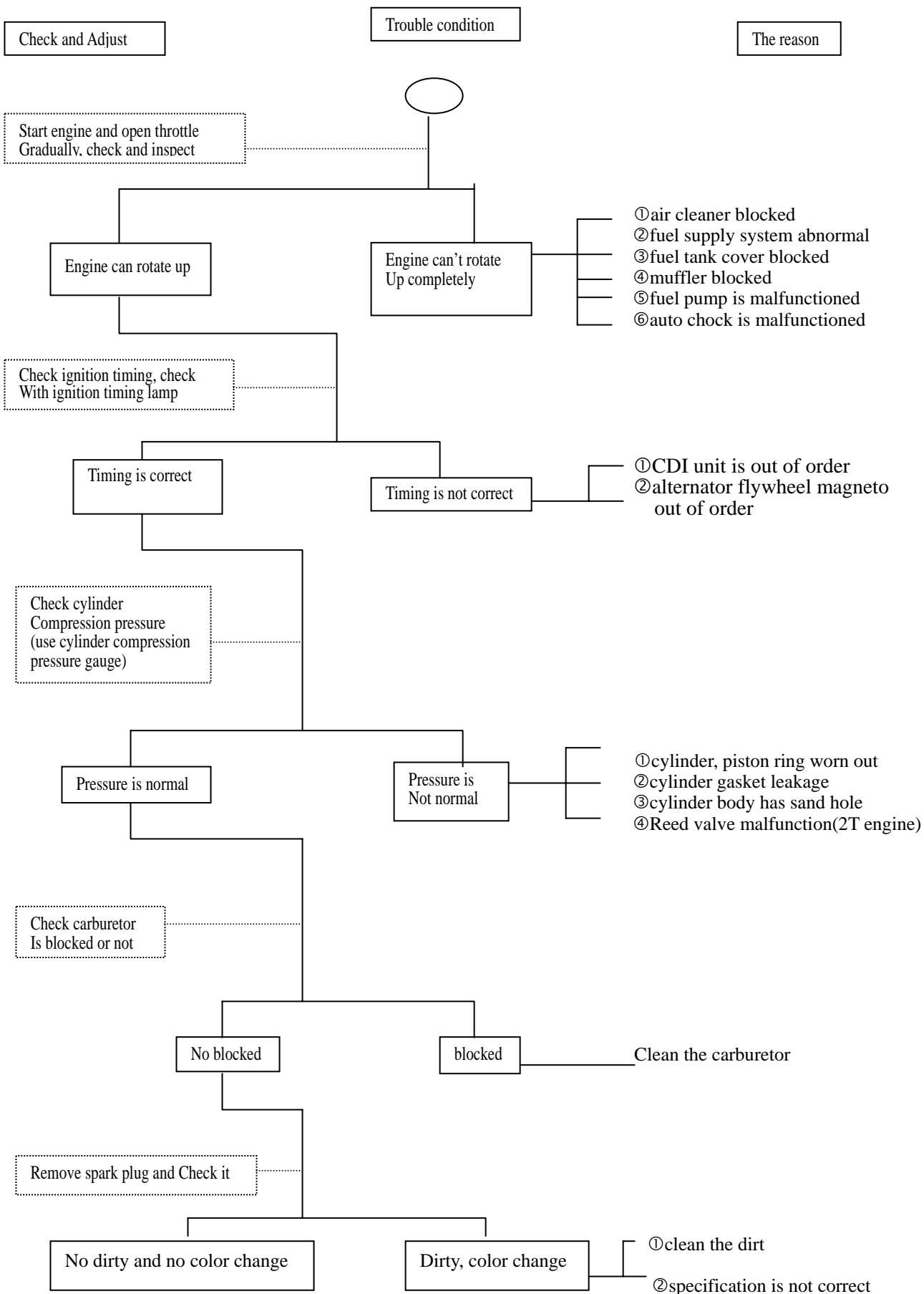

For 4T engine only:

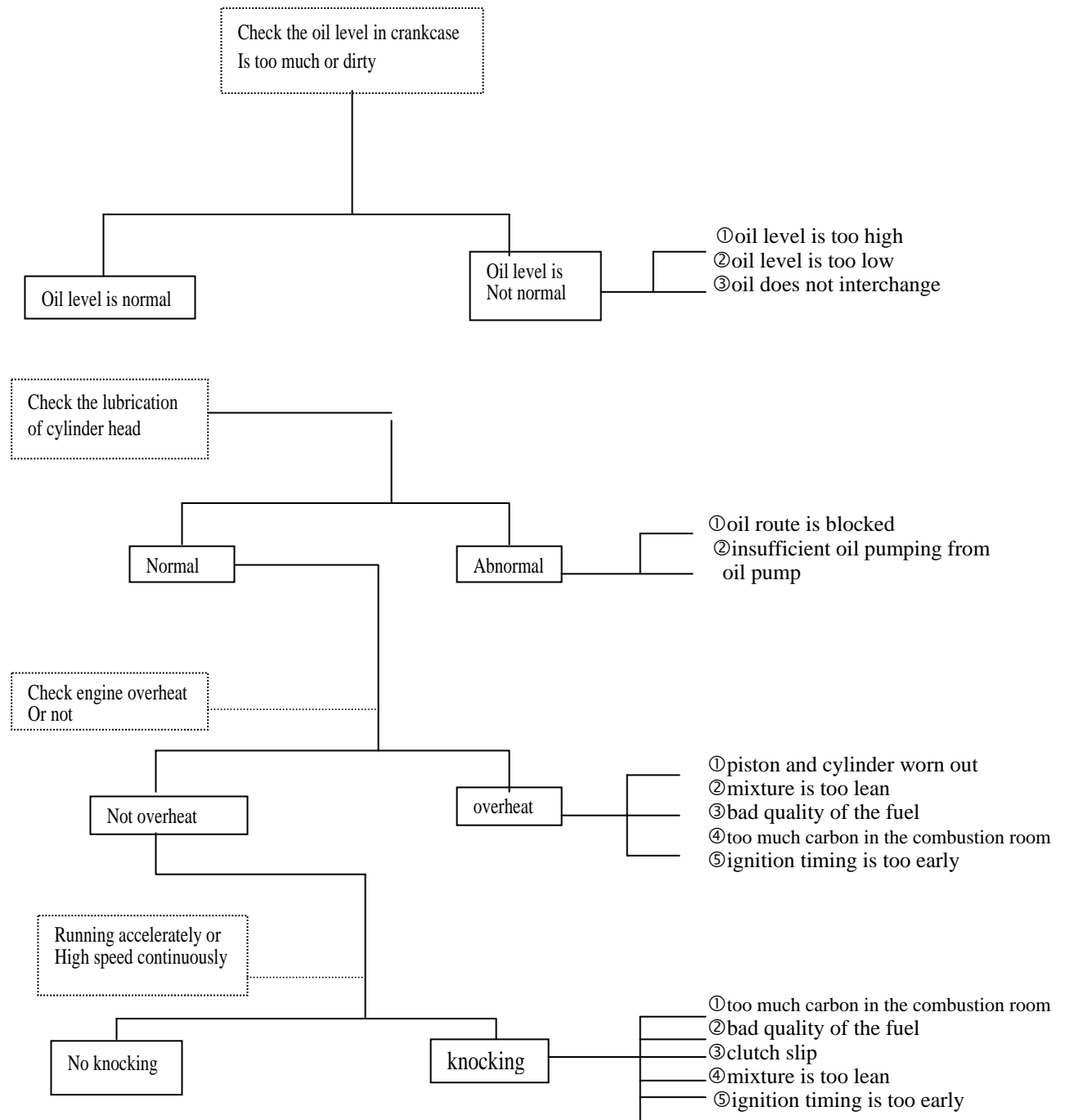

### 3.Engine running unsmoothly (low speed and idling)

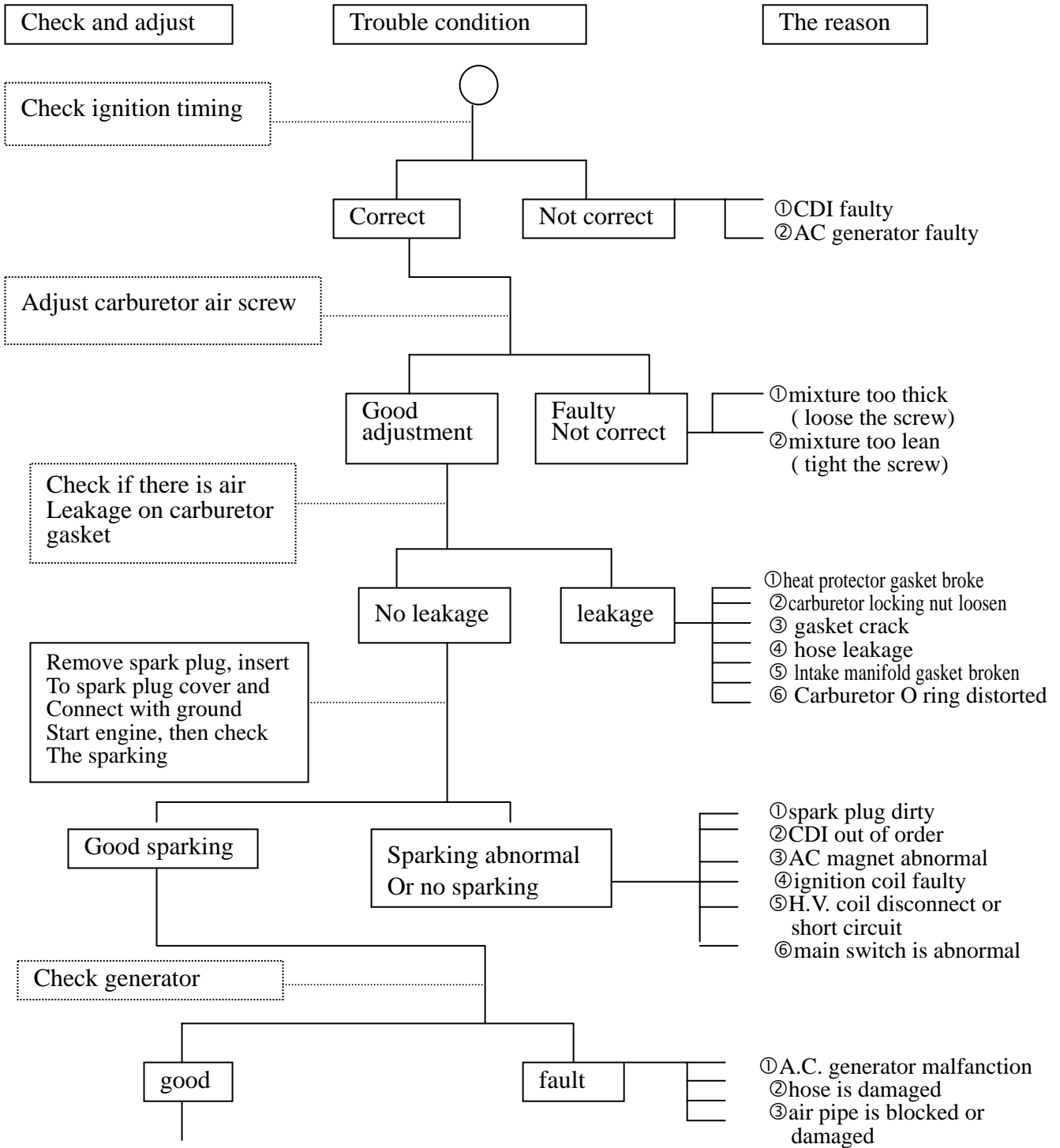



#### 4.Engine running unsmoothly (high speed)

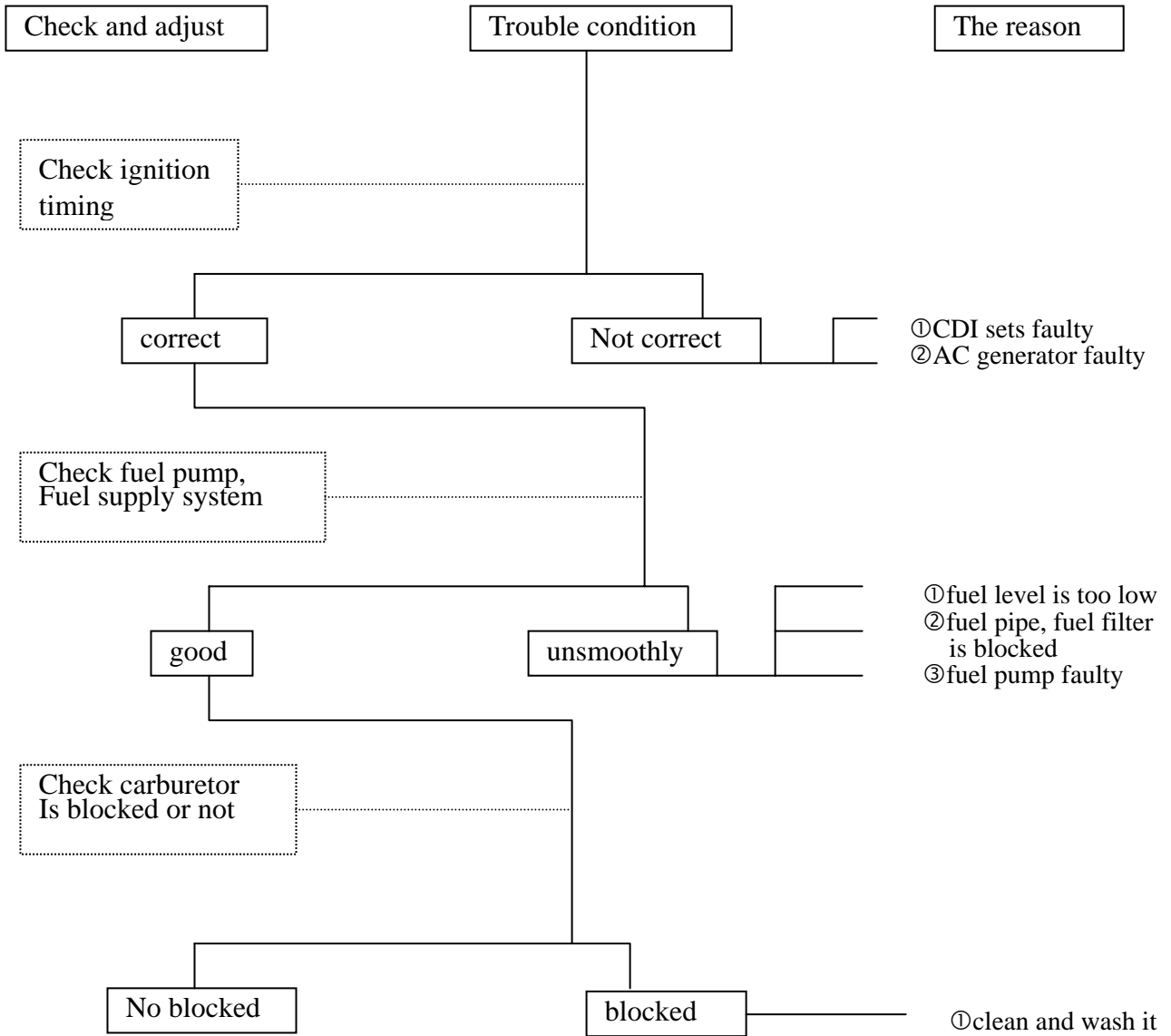

## 5. Clutch, drive and driven pulley

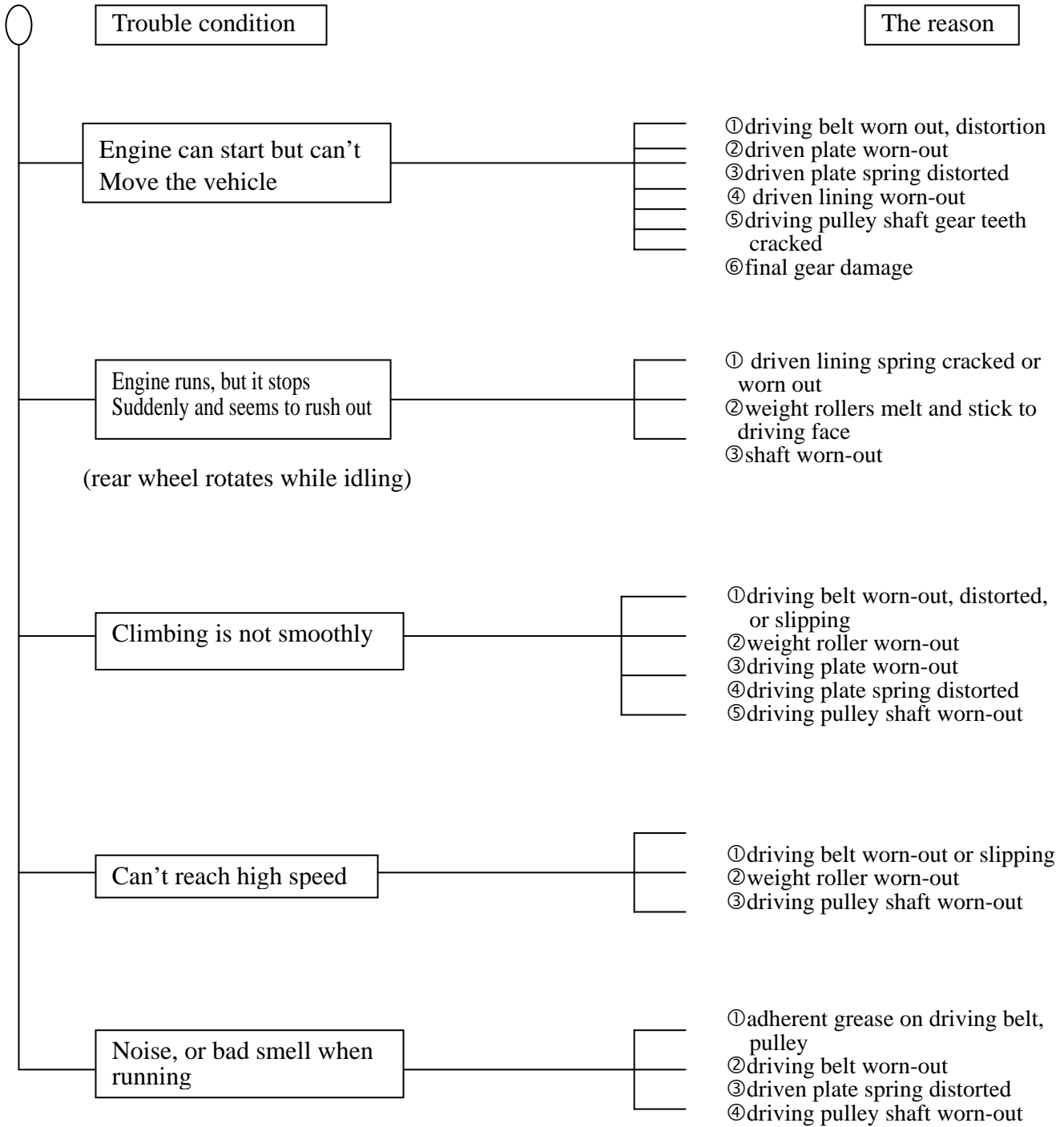

## 6. Handlebar steering astrayed when running.

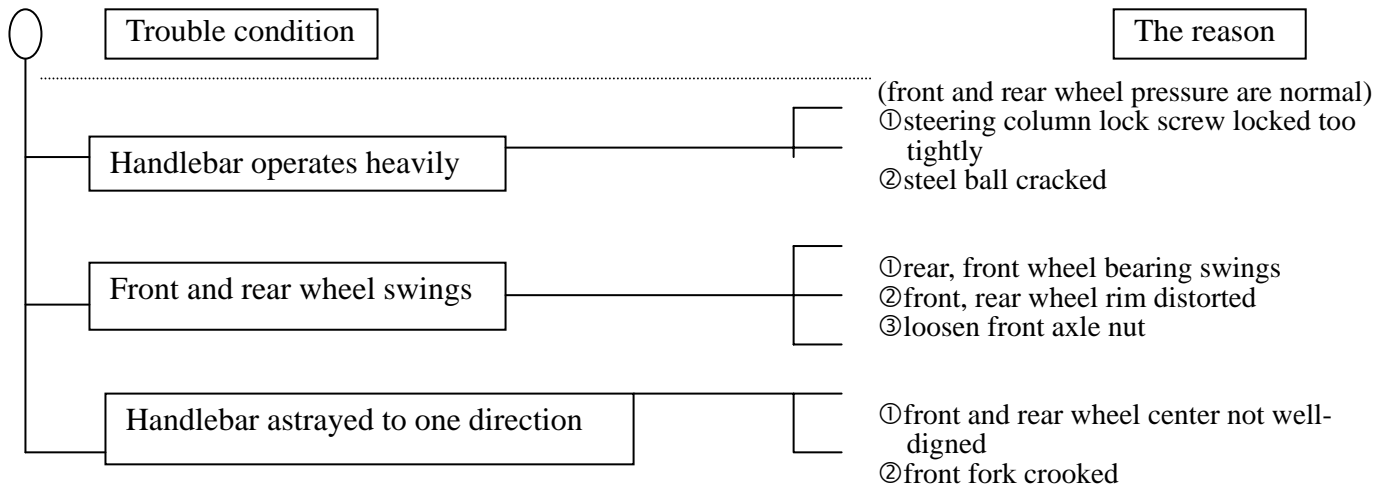

## 7. Front, rear damper not in balanced

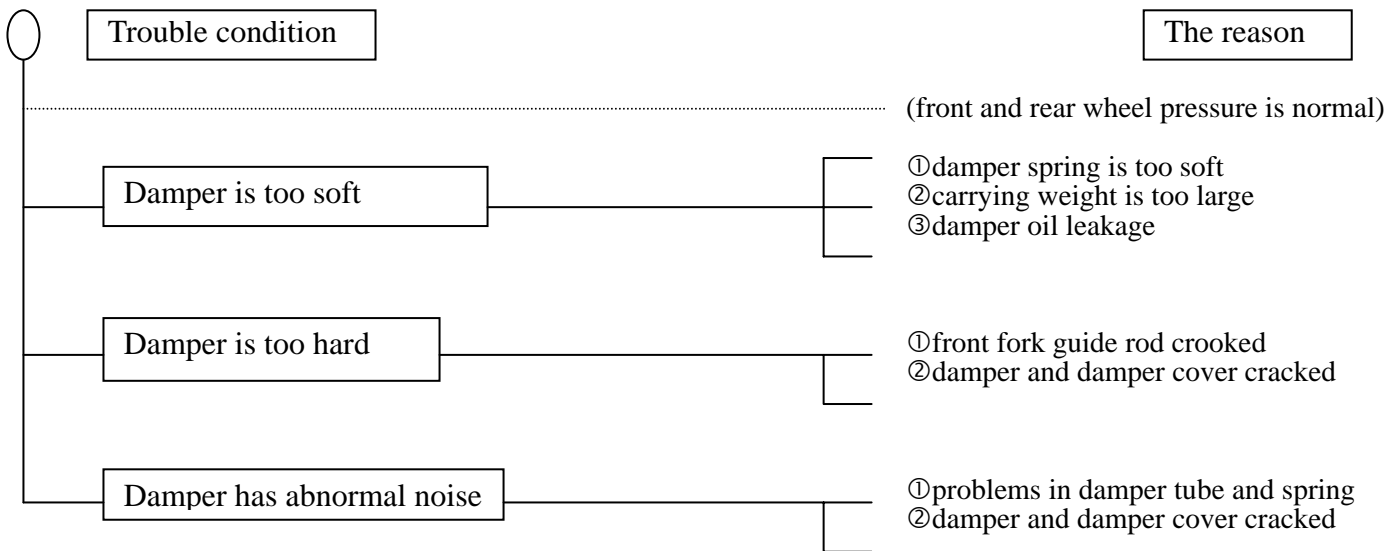

## 8. Brake disorder.

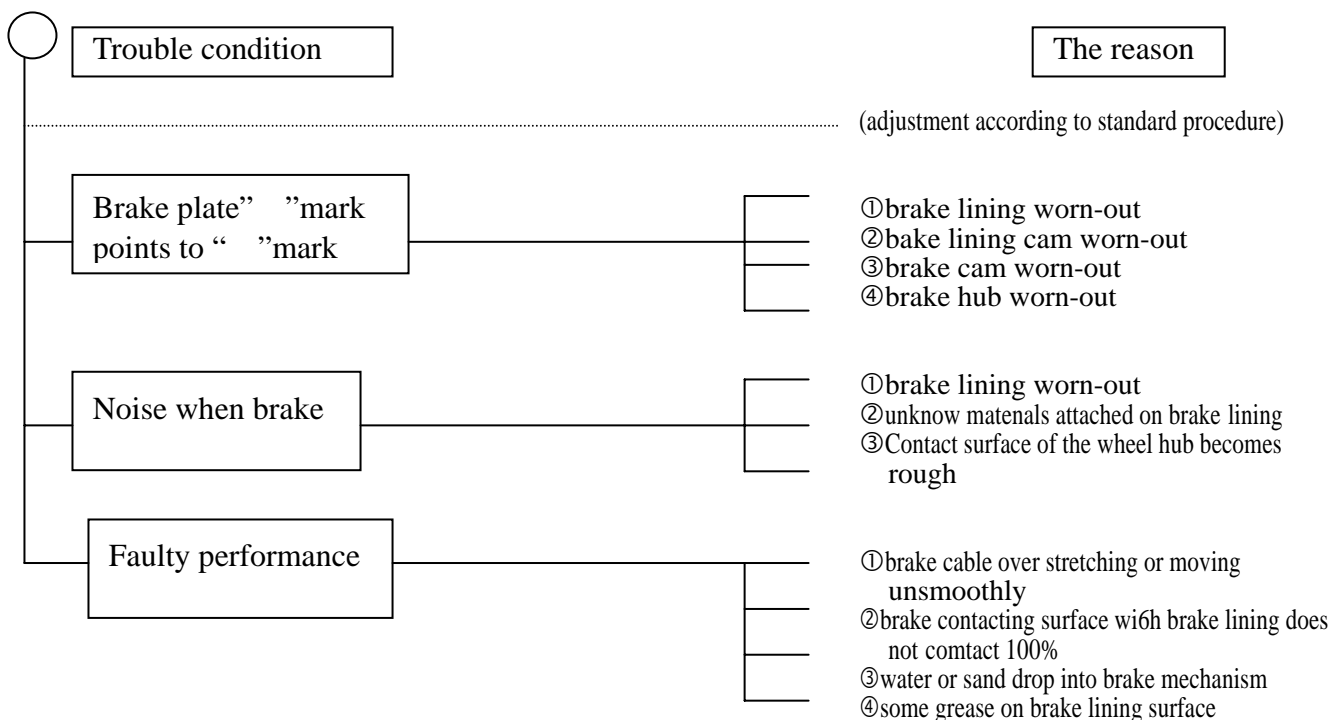

### 9.Oil indicator malfunction (Only available for 2T engine)

(a)The oil lamp doesn't light up, (when the main switch is at "ON" position)

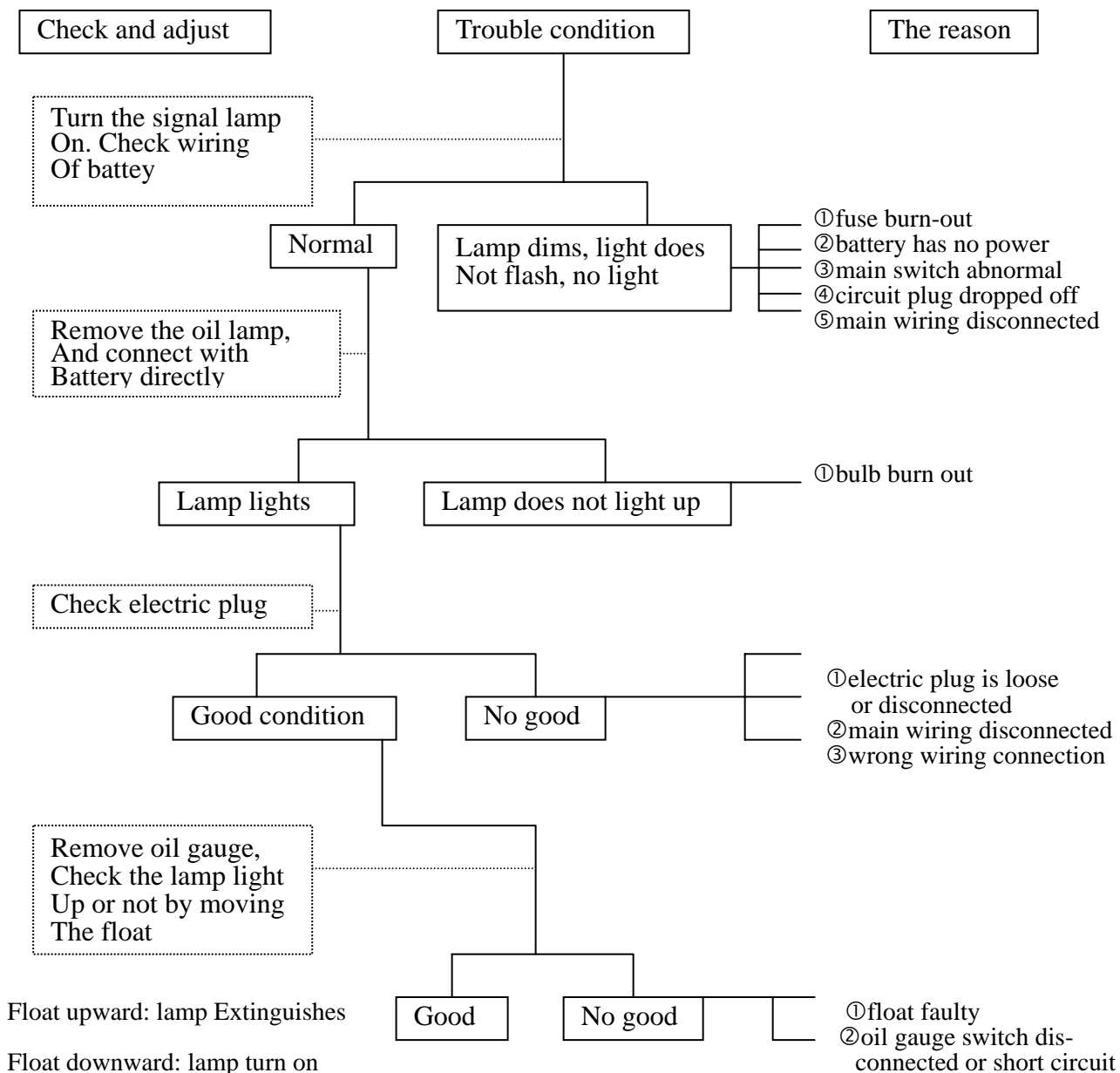

(b)Oil is enough but the indicator turns on all the time (when the main switch is "ON")

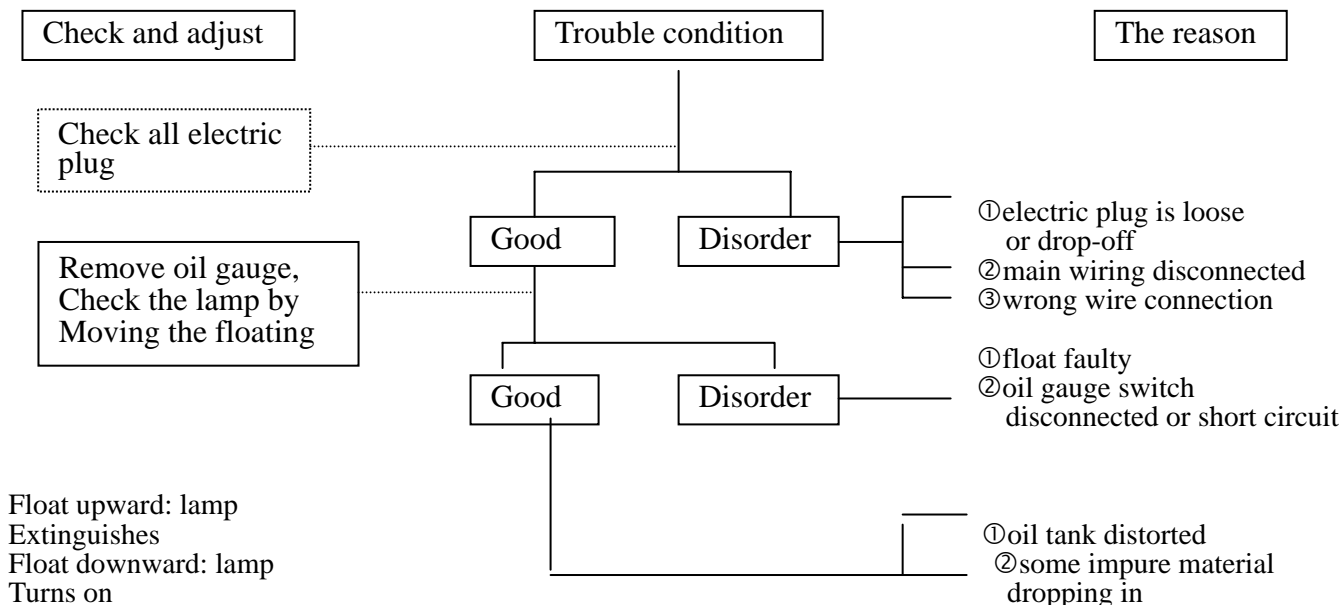

# 10. Fuel indication malfunction

(a) wrong fuel level indication (when the main switch is "ON")

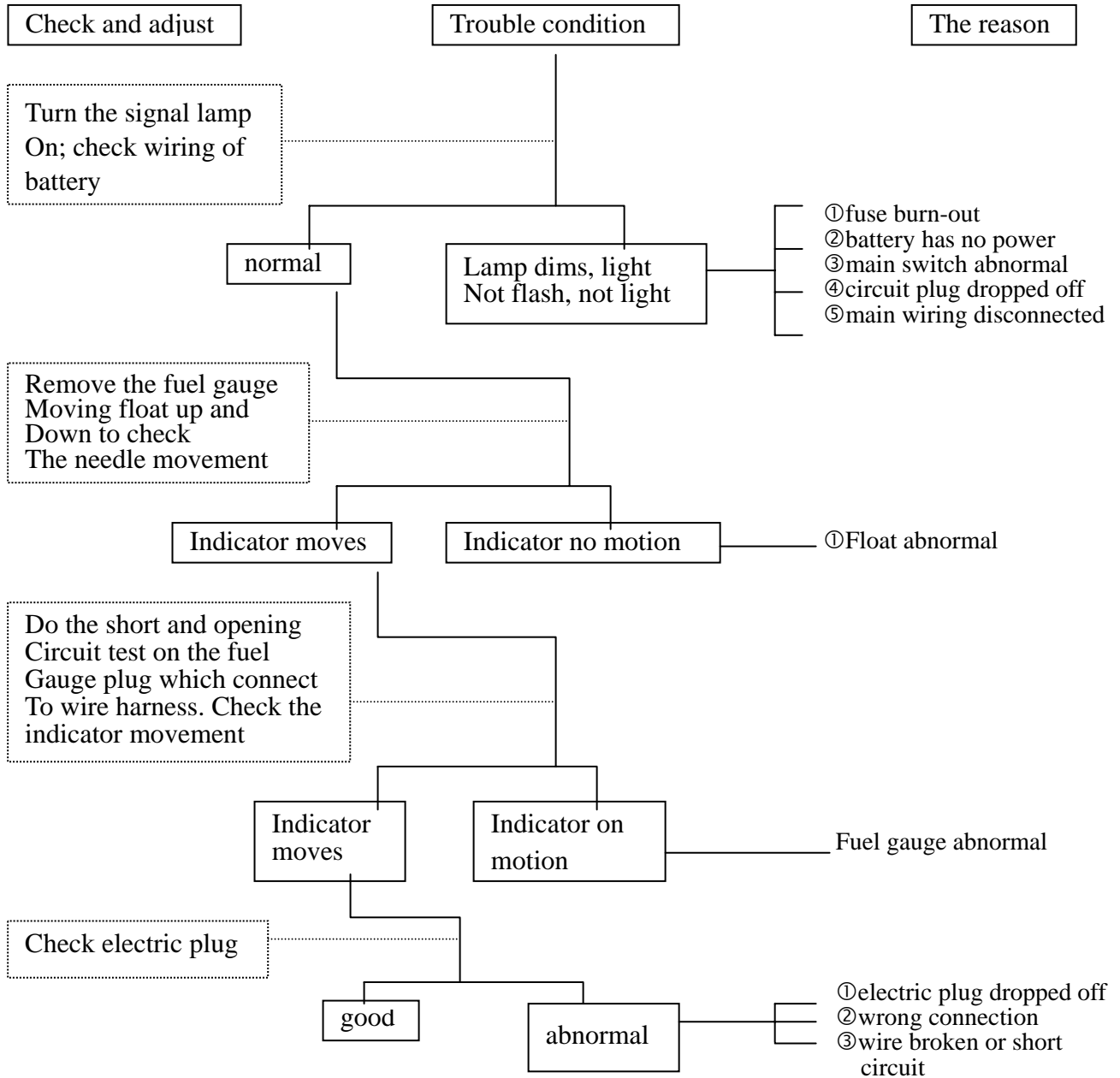

(b) Fuel gauge needle is not steady and sometimes moves up and down (when the main switch is "ON")

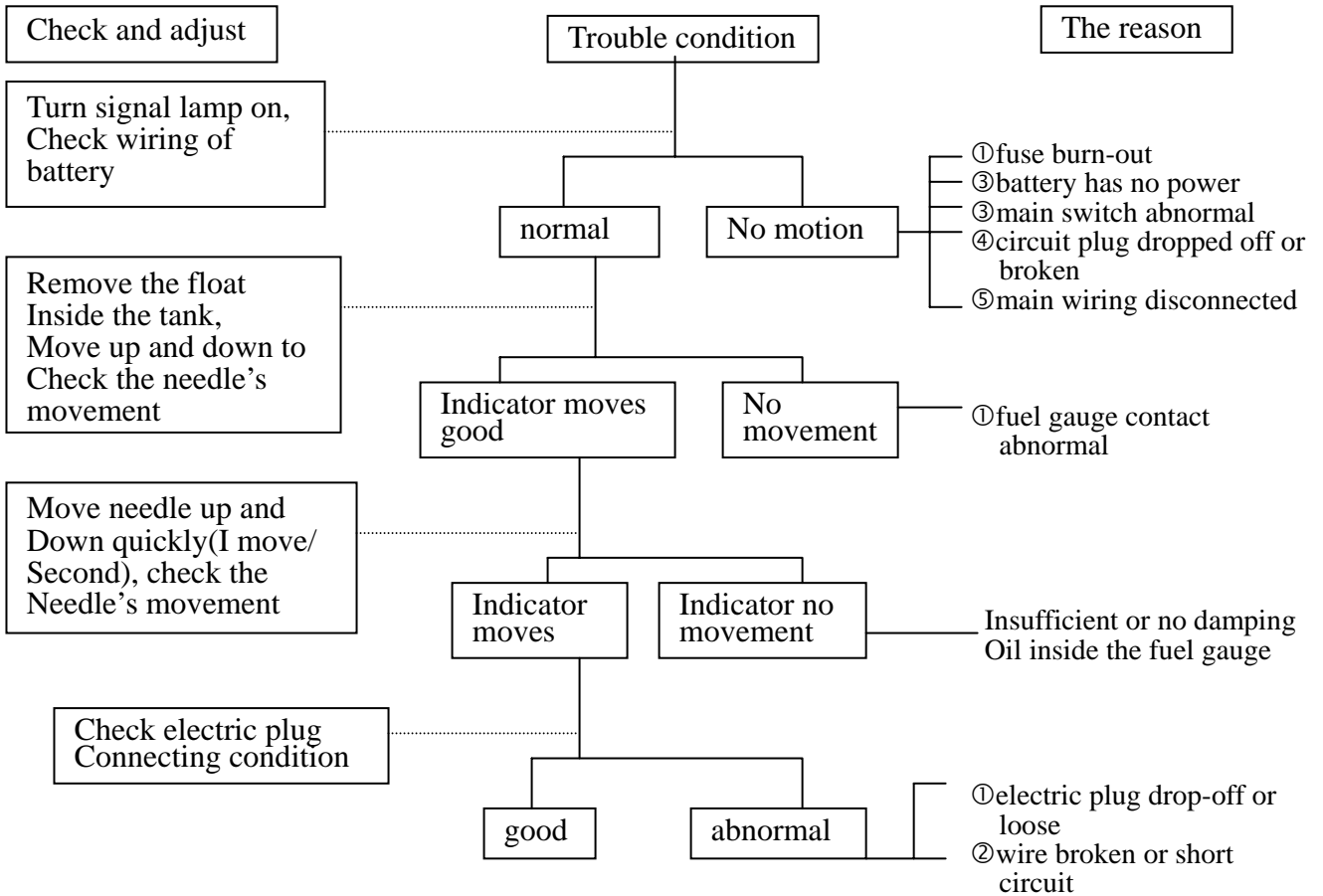

# 11. The starting motor abnormal

(a) Starting motor can not rotate

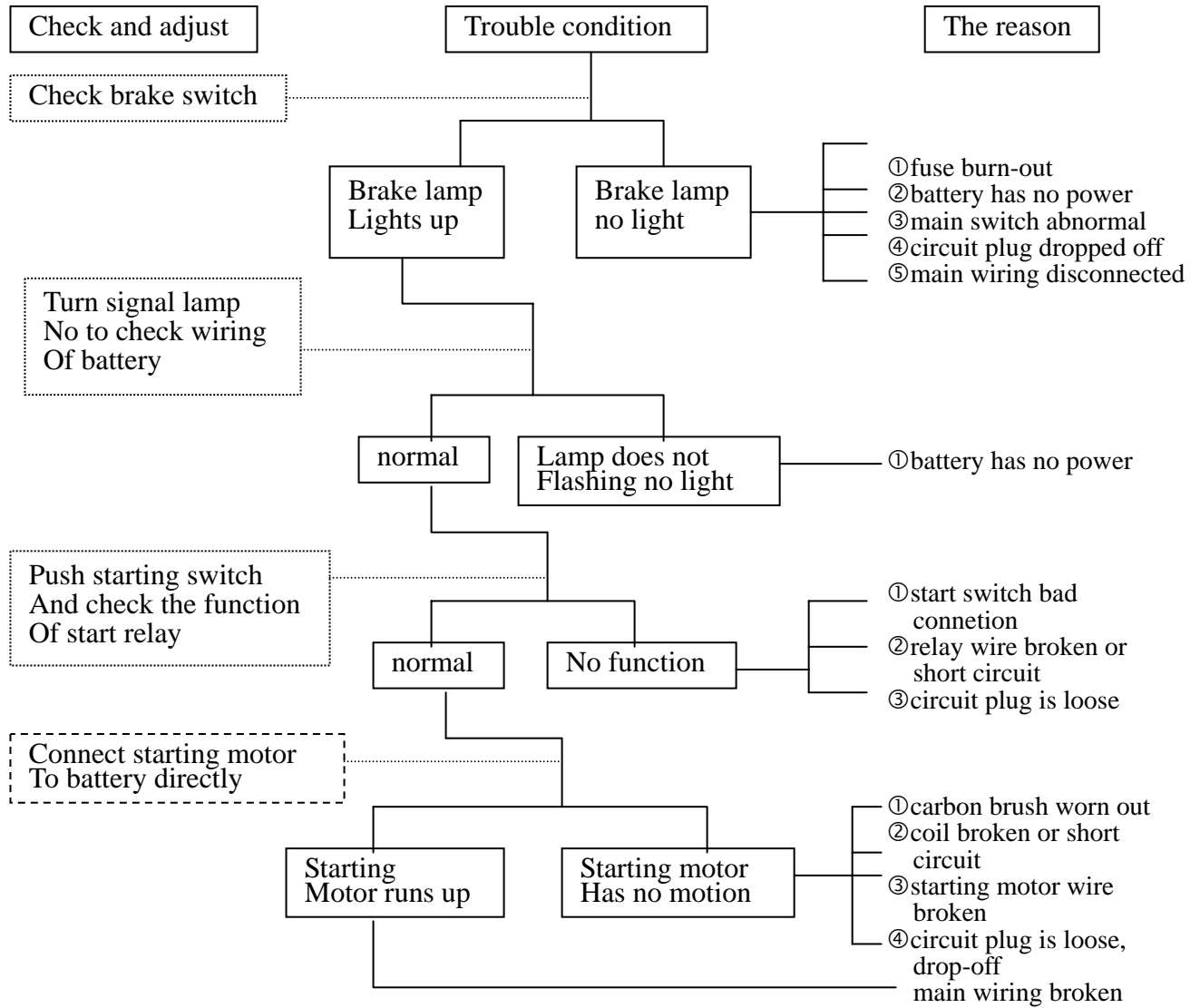

(b) Starting motor running slowly or no pick-up

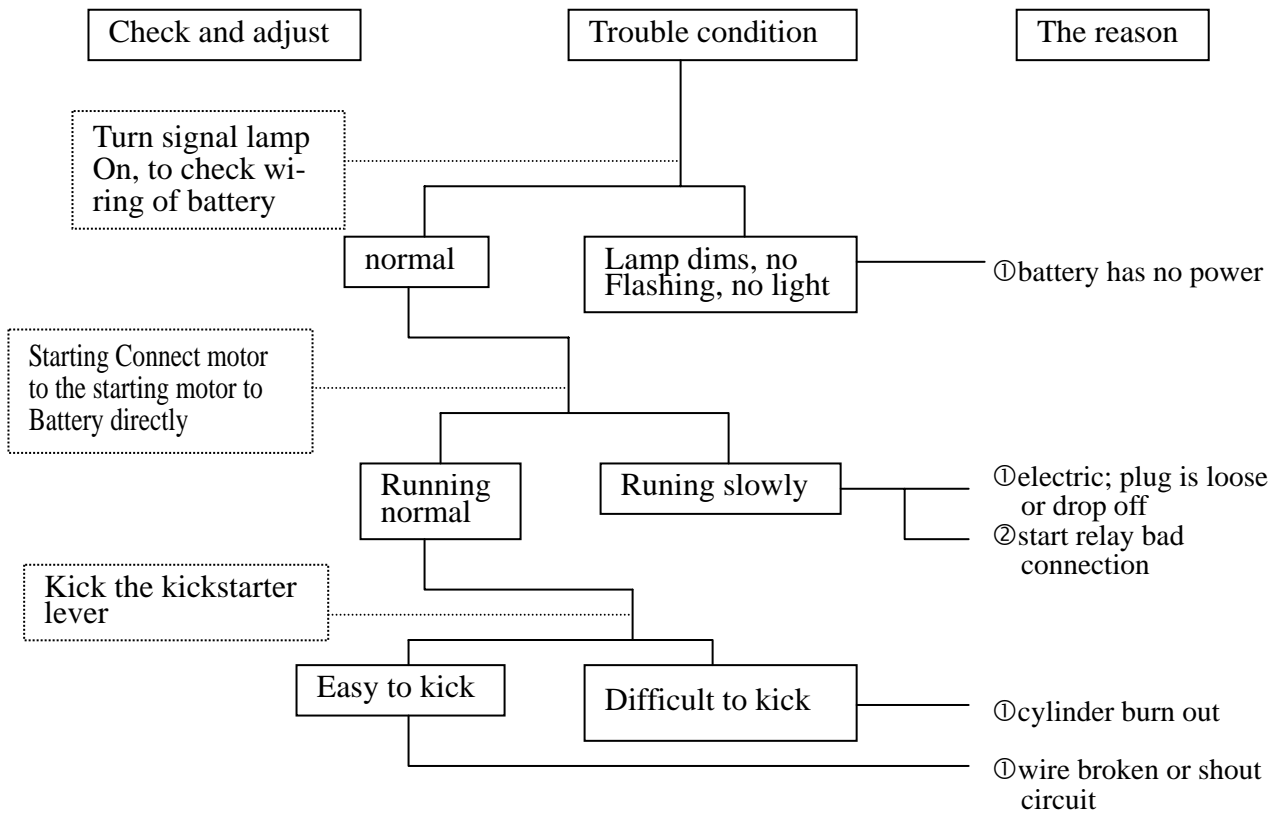

©Starting motor can not stop after starting

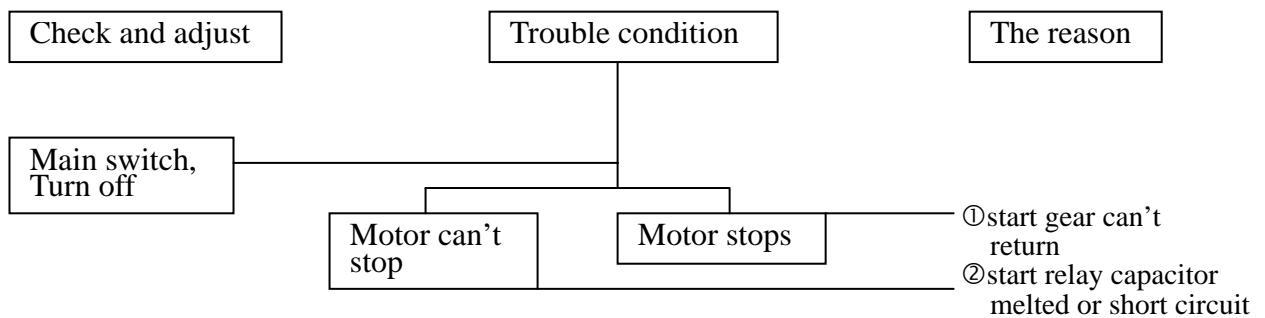



## 12.No sparking

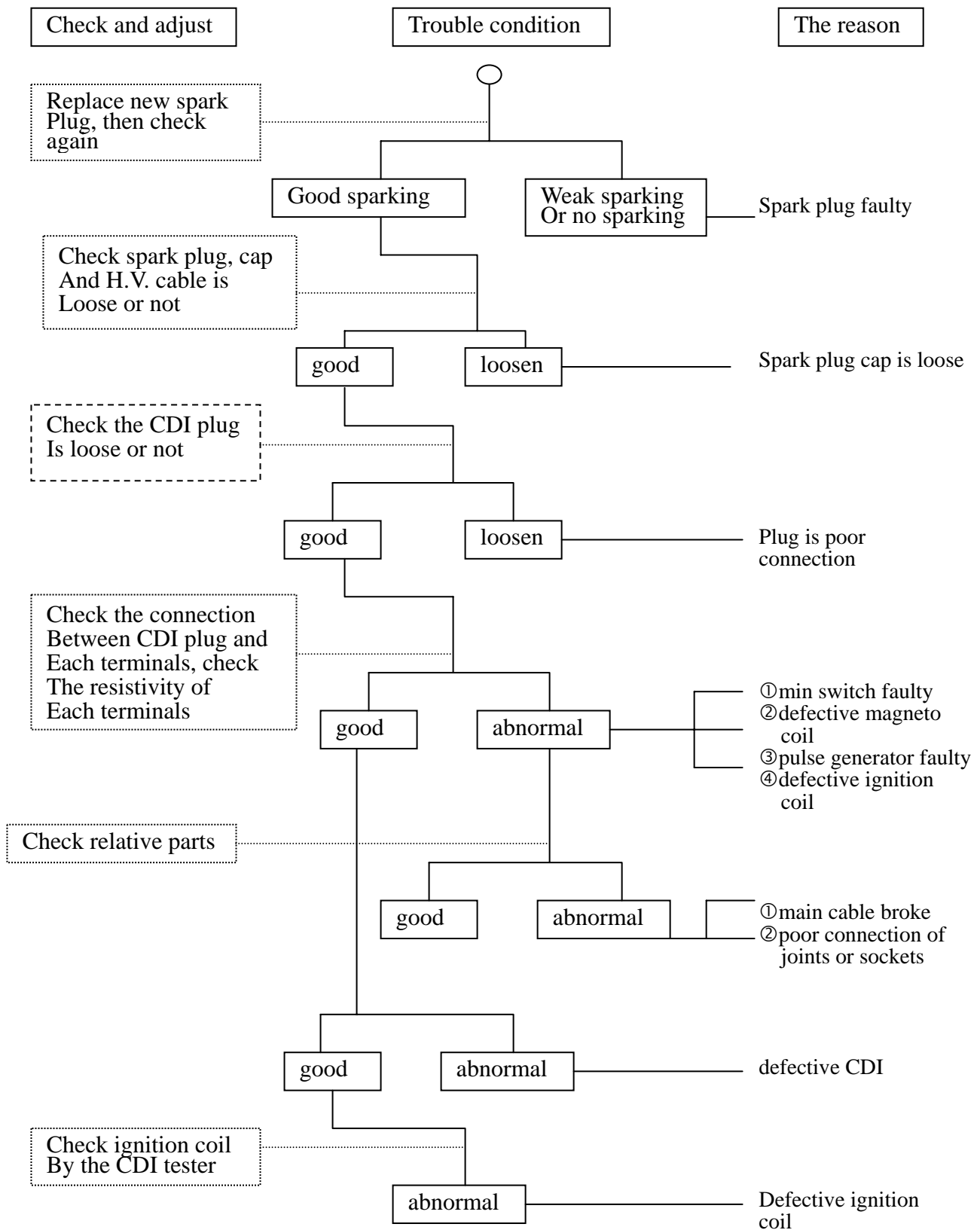

### 13.Charging abnormal(battery over charging or over discharging)

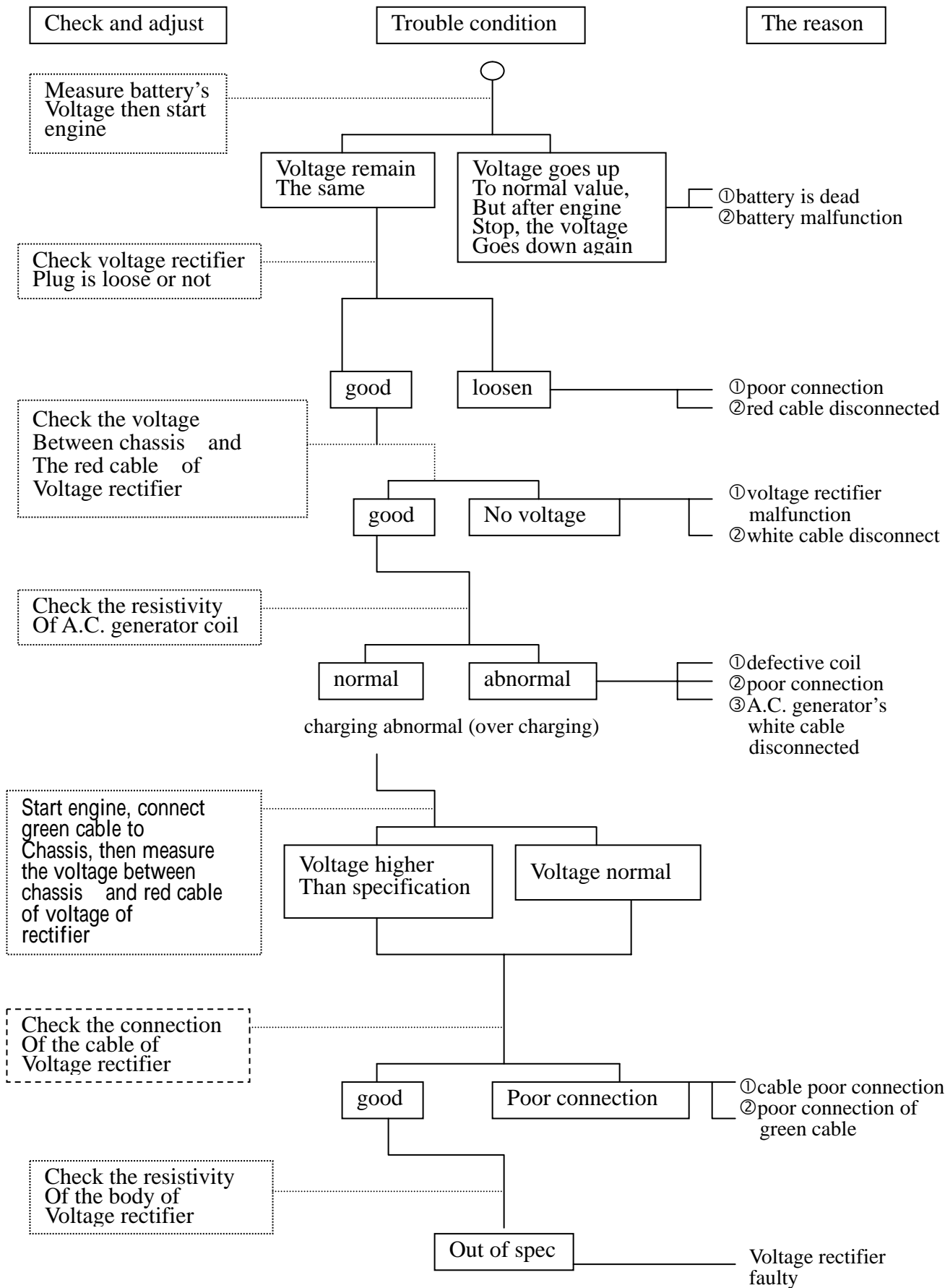

### **3. Checking and Adjustment:**

- (1)Regular checking table
- (2)Battery
- (3)Clean air cleaner
- (4)The final reduction mechanism oil
- (5)Spark plug
- (6)Compression pressure measurement
- (7)Ignition timing
- (8)Throttle cables adjustment
- (9)Idle adjustment
- (10)Front brake adjustment
- (11)Rear brake adjustment
- (12)Tire

# (1)Regular checking table:

1. 【○】 mark indicates periodical checking
2. 【※】 indicates changing the parts

Item			Checking period						Judgement standard	Remark	
			gen-eral che-cki ng	first month or Initial 300km	home		office				
					every6 months or 5000km	every12 months or 10000km	every1 months or 1000km	every3 months or 2500km			every12 months or 10000km
Suspension	Handlebar steering column	Loose or swing	○		○	○	○	○	○		
		Operation	○		○	○	○	○	○		
		Turning angle				○				○	
	front fork	Damaged			○	○	○	○	○		
		Shaft fixed condition			○	○	○	○	○		Check from Stering column
		Shaft:loose				○	○		○		Check from Stering column
Brake	Lever	a. clearance	○		○	○	○	○	○	Clearance: Front:10-20mm Rear :	
		b. movement of brake	○	○	○	○	○	○	○		
	Brake cable	loose or damage		○	○	○	○	○	○		
		Change brake cable									※every 2 ears
	Brake cam	worn out							○		
	Wheel hub and brake shor	a. clearance between hub and lining			○	○	○	○	○		
		b. brake shoe and brake lining worn-out				○			○		
c. wheel hub worn and damaged					○				○	standard dia:rear:110.0mm limit of use:rear:111.0mm	
Wheel	Front wheel axle	damaged or distorsion							○		
	Rear wheel axle	damaged or distorsion							○		
	tire	Pressure	○	○	○	○	○	○	○	unit: kg/c m <sup>2</sup> ;1 driver front tire   rear tire	
		Cracked or damaged	○		○	○	○	○	○		
		tire thread worn out	○		○	○	○	○	○	Change tire according to △mark	
		tire surface or other intruders	○		○	○	○	○	○		
	Axle	Tighten the bolt and nut			○	○	○	○	○	Front axle nut torque 5.0-6.0kg-m rear axle nut torque 11.0-13.0kg-m	Nut location
Rim	swingness and damage condition			○	○	○	○	○	Swingness limit Vertical: below 2.0mm Horizontal: below 2.0mm		

Item			Checking period						Judgement standard	Remark		
			gen-eral chec-ki ng	first month or Initial 300km	home		office					
					every6 months or 5000km	every12 months or 10000km	every1 months or 1000km	every3 months or 2500km			every12 months or 10000km	
wheel	Bearing	Clearance on Front axle		○	○	○	○	○	○			
		Clearance on rear axle			○					○		
Rear Damper	Spring	Damage Condition	○		○	○	○	○	○			
	Ass'y part	Loose or damaged condition			○	○	○	○	○			
	Connecting part	loose or				○			○			
	Bracket	loose or damage condition				○			○			
	Suspension arm	Looseness on Connecting Part				○			○			
	Absorber	Oil leakage				○			○	○		
		Damaged Condition				○			○	○		
Loose on ass'y part					○			○	○			
Transmission	Clutch and Shift mechanism	Function			○	○	○	○	○			
		Gear oil leakage			○	○	○	○	○		LH crank case	
	Gear oil	Change gear oil			○	○	○	○	○		90C.C. / replace 110C.C/ total	
Electric	Ignition	Spark plug			○	○	○	○	○	Clearance: 0.6~0.7mm NCK:BP7HS OR SAME SPEC		
	Start Mechanism	Starting motor gear				○		○	○			
	Wiring	Recharge Function			○	○	○	○	○			
	Battery	Electrolyte level			○	○	○	○	○	Level between "UPPER" and "LOWER"		
		Electrolyte gravity				○			○	○	When 20°C Specific gravity: 1.270-1.290	
Wire circuit	Looseness or Damage on connection plug			○	○	○	○	○				

Item		Checking period							Judgement standard	Remark	
		gen-eral che-cki ng	first month or Initial 300km	home		office					
				every6 months or 5000km	every12 months or 10000km	every1 months or 1000km	every3 months or 2500km	every12 months or 10000km			
Engine mechanism	Engine parts	Performance, Noise			○	○	○	○	○		
		Low speed, Acceleration			○	○	○	○	○	Idling: 1900±100rpm	
		Exhaustion	○		○	○	○	○	○		Check the color of exhausting-air
		Air cleaner			○	○	○	○	○		
		Cylinder, cylinder head, inlet pipe, locking Condition							○	Locking torque Cylinder head: (cold) 1.0-1.2KG-m inlet pipe: cold) 1.0-1.2kg-m	
		Compression Pressure (G-MAX 50)				○			○	6kg/c m <sup>2</sup> @ 600rpm	Using starting motor
		Compression Pressure G-MAX 125				○			○	12kg/c m <sup>2</sup> @ 750rpm	Using starting motor
		Compression Pressure G-MAX 150				○			○	11kg/c m <sup>2</sup> @ 650rpm	Using starting motor
	Lubrication system	Oil leakage			○	○	○	○	○		
		Oil quantity, Dirty			○	○	○	○	○		
		Oil quantity,	○								
		Oil filter blocked				○	○	○	○		
	Fuel system	Fuel quantity	○								
		Fuel leakage			○	○	○	○	○		
		Clean Carburetor			○	○	○	○	○		
		Carburetor's Throttle and Choke function			○	○	○	○	○		
		Carburetor Float height			○	○	○	○	○		
		Carburetor Adjustment			○	○	○	○	○		
		Change fuel pipe								※every 4 years	

Item		Checking period							Judgement standard	Remark
		gen-eral che-cki ng	first month or Initial 300km	home		office				
				every6 months or 5000km	every12 months or 10000km	every1 months or 1000km	every3 months or 2500km	every12 months or 10000km		
Lamp system	Function	<input type="radio"/>		<input type="radio"/>	<input type="radio"/>	<input type="radio"/>	<input type="radio"/>	<input type="radio"/>		
	Dirty or broken	<input type="radio"/>		<input type="radio"/>	<input type="radio"/>	<input type="radio"/>	<input type="radio"/>	<input type="radio"/>		
Horn, signal Lamp, reflector	Function	<input type="radio"/>		<input type="radio"/>	<input type="radio"/>	<input type="radio"/>	<input type="radio"/>	<input type="radio"/>		
lock	Function			<input type="radio"/>	<input type="radio"/>	<input type="radio"/>	<input type="radio"/>	<input type="radio"/>		
Rear view mirror	Dirty or broken	<input type="radio"/>		<input type="radio"/>	<input type="radio"/>	<input type="radio"/>	<input type="radio"/>	<input type="radio"/>		
License plate	Dirty or damaged	<input type="radio"/>								
Dashboard	Function	<input type="radio"/>		<input type="radio"/>	<input type="radio"/>	<input type="radio"/>	<input type="radio"/>	<input type="radio"/>		
Muffler silencer	Losseness or Damage on Ass'y part			<input type="radio"/>	<input type="radio"/>	<input type="radio"/>	<input type="radio"/>	<input type="radio"/>		
	Function				<input type="radio"/>		<input type="radio"/>	<input type="radio"/>		
chassis	Loose or Damaged				<input type="radio"/>		<input type="radio"/>	<input type="radio"/>		
The previous Abnormal case	Confirm it does Not happen Again	<input type="radio"/>								
others	Chassis Lubrication			<input type="radio"/>	<input type="radio"/>	<input type="radio"/>	<input type="radio"/>	<input type="radio"/>		
	Decarbonate on Combustion room And muffler				<input type="radio"/>			<input type="radio"/>		

## (2) Battery: Recharge when power is out

1. Remove the rear luggage cover by hand.
2. Screwing out the two screws on the battery cover. Remove the battery cover. (G-MAX125/150)
3. Remove the negative cable and then the positive cable, → take out the battery to recharge.
4. To re-assemble the battery, please follow the opposite procedure of disassembling after recharging.



**Positive Pole**

**Negative Pole**

Note:

A. The battery is totally sealed, do not remove seal bolts when recharging

B. It's no need to add any electrolyte for this re-filling free battery

Please recharging (12V) by the following currency

**G-MAX50: Standard recharging:0.4A\* 5-10 hr or rapid recharging:3A\* 30min.**

**G-MAX125/150: Standard recharging:0.7A\* 5-10 hr or rapid recharging:3A\* 30min.**



### (3)Cleaning air cleaner

- 1.Remove air cleaner cover
- 2.Take out the air cleaner filter

G-MAX50



G-MAX125/150



- 3.Clean the filter by the compressor air.



- 4.Assemble the air cleaner by the opposite procedure.

Note: Do not start the engine When the air cleaner is Not installed

#### (4)The final reduction mechanism oil

- 1.Change the oil in the gear box:
  - a. Turn off the engine after warm up.
  - b. Put a bowl under the engine.
  - c. Remove the draining bolt and Filler bolt to drain the gear oil off.
  - d. Lock the draining bolt before refill 90c.c gear oil and then lock the filling bolt.
  - e. Locking torque: 1.8kg-m

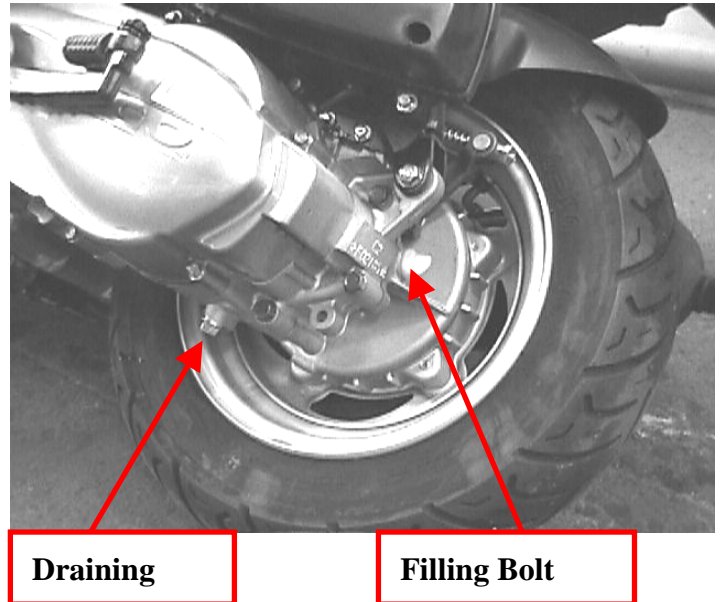

Note: Be sure the crankcase, tire or wheel are cleaned if there is grease/oil on it

#### (5)Spark plug

- 1.Remove spark plug
- 2.Check the spark plug electrode and check if it is  
Burnt out or not and carbonized or not
- 3.Clean the electrode, whether it is dirty
- 4.Spark plug specification  
**G-MAX50: BP7HS (NGK) or equivalent spec.**  
**G-MAX125/150: C7HSA (NGK) or equivalent spec.**

Gap of spark plug:0.6~0.7mm

Electrode burn out/  
Carbon piled up

Washer is  
Distorted or not

Procelain is  
Cracked or not

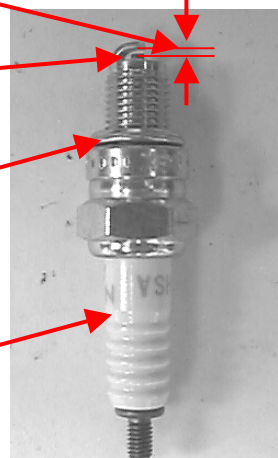

## **(6) Compression pressure measurement:**

1. Measure it when the engine is warm.
2. Remove the cover.
3. Remove spark plug then place compression pressure gauge.
4. Fully open the throttle, and using starting motor 5 seconds continuously, measure the compression pressure.
5. Compression pressure:
  - 50cc: 6 kg/c m<sup>2</sup> @600rpm**
  - 125cc: 12 kg/c m<sup>2</sup> @750rpm**
  - 150cc: 11 kg/c m<sup>2</sup> @650rpm**
6. when the compression pressure is too low, check the following:
  - a. cylinder head gasket cracked.
  - b. piston cylinder worn out.
  - c. piston ring worn out.
7. If the compression pressure is too high it may be due to the carbon piled up on combustion chamber and piston tip.



## (7) Ignition timing:

This scooter is using CDI set, it is no need to adjust ignition timing.

If ignition timing is not correct, check the CDI sets AC magneto, change it if it is abnormal.

checking ignition timing:

- 1.remove seat the luggage compartment
- 2.Remove right body cover
- 3.Remove the fan case.
- 4.Check with ignition timing lamp.  
keep the engine running at  $1,900 \pm 100$  r.p.m the checking mark should lay in  $\pm 3^0$  apart From "F", mark.
- 5.ignition timing: B.T.D.C.  
 $17^{\circ} \pm 3^{\circ} / 1900\text{rpm}$



## (8)Throttle cables adjustment:

- 1.check the clearance of throttle.
- 2.Normal clearance:1.5-3.5mm
- 3.Adjust it by rotating the adjust nut ; change it if the throttle cables can't be adjusted.



## **(9) Idle adjustment:**

Note: adjust it when the engine is warm.

- 1.remove left body cover
- 2.start the engine and connect the tachometer
- 3.adjust the throttle valve screw  
to the specified revolution  $1900 \pm 100$ rpm.
- 4.if the idling rpm is still unsteady or  
fuel up is not smooth, please adjust it by  
followings.
  - a. Screw in the air adjust screw clockwise,  
then screw out counterclockwise.  
Recommended loop:  $1 \frac{3}{8} \times 1/2$
  - b. Rotate air adjust screw clockwise and counterclockwise to find out the highest  
revolution location.
  - c. Rotate the throttle valve screw to idling condition.
  - d. Fuel up gradually until the idling running rpm is steady.
  - e. If the rpm is still not steady please repeat above procedure.

## **(10)front brake adjustment:**

- 1.check the clearance of front brake lever.  
Clearance:10-20mm
- 2.if the clearance is beyond, standard check whether:
  - a. The air mix into the pipe/caliper.
  - b. The oil brake system is leaking.

Note:  
Try brake lever to see if it's loose.  
Check the brake fluid. Once air mixed in  
The fluid pipe, which will reduce or  
Damage the brake efficiency or even its  
Function.

- 3.check the fluid level:
  - a. Refill the brake fluid when the level is under the LOWER line.
  - b. Brake fluid specification: SAE J-1703F-DOT3&DOT4.

Note:

- a. To prevent the fluid splitting onto the parts or clothes, put a piece of cloth on  
the bottom when refilling.
- b. Be caution not to mix water or particles into the master cylinder when refilling.
- c. Never use the fluid not complied with spec.
- d. In case the fluid stains on the eyes, wash with water at once and then ask for  
medical care immediately.



## (11)Rear brake adjustment (drum brake only)

- 1.Check the clearance  
Of rear brake lever.  
Clearance: 10-20mm
- 2.If the clearance is  
beyond the above standard,  
Adjust it by rotating the screw.
  - a. Left-handed rotation-enlarge  
the clearance.
  - b. Right-handed rotation-reduce the clearance.



**Note:**

When the arrow of rear brake indicator align with the arrow of left crankcase, change the brake lining.

## (12)Tire:

- 1.Check the tire air pressure(when it's cold)
- 2.Tire pressure:  
Front tire: 2.0 kg/c m<sup>2</sup>  
Front tire: 2.0 kg/c m<sup>2</sup>
- 3.Tire dimension:  
**G-MAX 50:**  
**Front tire: 120/70-12**  
**Rear tire: 130/70-12**  
**G-MAX 125/150:**  
**Front tire: 120/60-13**  
**Rear tire: 130/60-13**



**Note:**

- a. Check and adjust the tire pressure when it is too low.  
The pressure is according to the carrier, Driver, passenger, accessories and cruise Speed.
- b. Proper loading is very important for steering, riding, braking, performance and safety.
- c. Never carry any parcel unfastened.
- d. Load the heaviest parcel on the center of vehicle, balancing the weight on both sides.
- e. Beware of the weight loaded properly and check the tire pressure. The total weight of carrier, driver, passenger, and accessories cannot exceed the approved limit, An overload vehicle is easy to cause tire damage and accident for rider.

- 4.Check is there any sharp Object pierce the tire.
- 5.Check the depth of tire Thread.
  - a. Depth(front & rear):  
According to mark of tire “▲”to change a new tire

## 4.1 Plastic part dismantle Overview

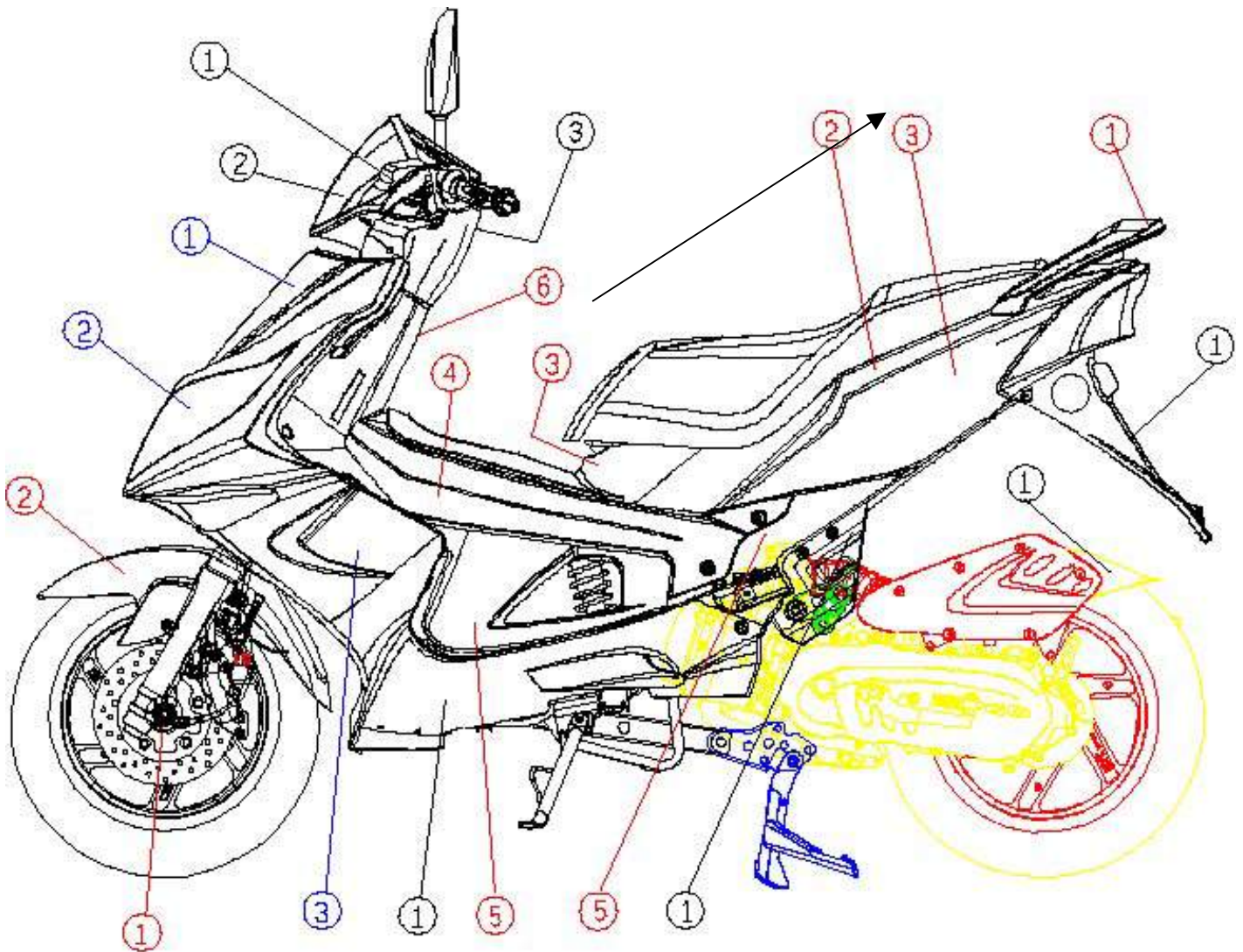

Dismantle the plastic parts according to above figure sequence by sub-assembly, especially pay attention to followings:

- Before dismantle front fender, dismantle the front wheel assy. First. (G-MAX125/150 only)
- Windshield & frt signal lamp cover shall be dismantled together.
- LH & RH body cover shall be dismantled together.

## ● Actual dismantle procedure:

- Dismantle the upper cover & windshield.
- Loosen 2 tapping screws at the upper with the inner cover.
- Withdraw the windshield decorated cover.



- Dismantle the handle upper cover.
- Loosen 5 tapping screw under the handle.



- Dismantle windshield & turn signal front cover.
- Loosen 1 tapping screw under windshield.
- Loosen 1(LH) & 1(RH) tapping screw under turn signal front cover.





- Loosen 3(LH) & 3(RH) tapping screws of front inner cover.



- Loosen 3(LH) & 3(RH) tapping screws of front inner cover.



- Loosen 1 machine screw in the middle of windshield.
- Dismantle windshield & front turn signal cover together.



- Dismantle the front fender.
- Only for G-MAX125/150:  
Loosen nut of front wheel, dismantle the front wheel & brake disc together.
- Loosen screws at LH & RH of front fender, dismantle front fender



- Open the seat.
- Loosen 3 bolts of rear luggage bracket, dismantle it.



- Loosen 4 bolts of front luggage compartment.
- Disconnect the coupling of lighting lamp, dismantle the front luggage compartment.



- Loosen 2 bolts of rear luggage compartment



- Lift the cover with finger, withdraw the cover of rear luggage compartment.
- Withdraw the rear luggage compartment.



- Turn the tank inner cover counterclockwise a little bit, dismantle it.
- Dismantle the tank upper cover by releasing coupling ribs
- Withdraw fuel tank decorated cover.



- Dismantle the keel cover.
- Loosen 2(LH) & 2(RH) screws at the front upper section.



- Loosen 2(LH) & 2(RH) inner socket screws, dismantle the keel cover.



- Dismantle the LH & RH lower cover
- Loosen 4 tapping screws on the top of LH & RH lower cover
- Dismantle quick plastic screw(2 EA in each side)





- Dismantle 1 tapping screw in the front side.
- Withdraw LH & RH lower cover.



- Dismantle other PP covers.



- Dismantle the license plate
- Push the middle of quick plastic screw.



- Loosen 2 screws at the rear of vehicle.
- Withdraw the license plate.



#### **4.G-MAX 50 Engine dismantle, maintenance, repair and assembly:**

- (1) Lubrication system
- (2) Engine dismantling
- (3) Drive pulley, starter, clutch,
- (4) Cylinder and, piston
- (5) AC Generator
- (6) Final transmission mechanism
- (7) Crankcase, crankshaft.
- (8) Carburetor, reed valve

## (1)Lubrication system and oil pump

### 1.Lubrication system diagram.

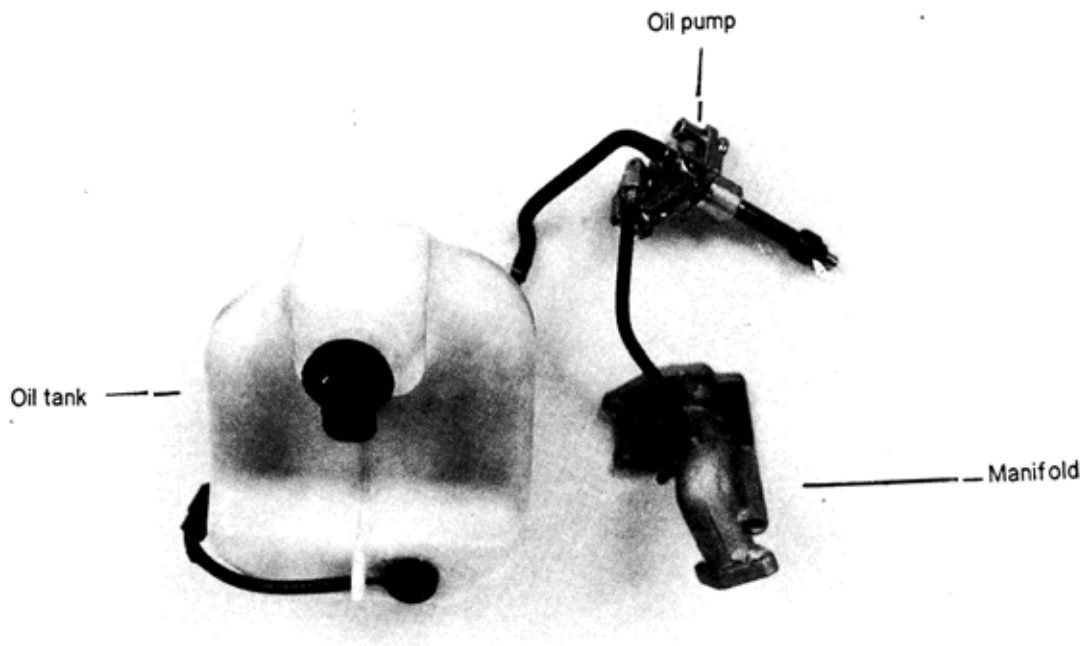

#### B. Engine over heating:

- a. The adjustment of oil pump is not properly.(lack of oil)
- b. The quality of oil is not good.

#### C. Piston over burning.

- a. There is air in the oil pump system.
- b. Oil pump is out of order.

#### D. The route from oil tank to oil pump is blocked.

- a. Ventilation hole on the tank cover is blocked.

Note:1.When removing oil pump, do not drop any unexpected objects into the oil pipe.  
2.Please release the air if there is air trapped in the oil pipe.  
3.Locking torque of oil pump:0.8-1.2kg-m

### 3. Removing the oil pump.

Clean the oil pump and Crank case before operation

- a. Remove the luggage.
- b. Remove the input/output oil pipe.
- c. Take out the oil pump by removing The locking screw on oil pump and Oil gauge cable.



### 4. check the oil pump.

Remove oil pump and check:

- a. O-ring is distorted or not.
- b. contact area of crankcase is injured or not.
- d. Oil pump body is damaged or not
- e. The movement of control lever is free or not (110 cc model only)
- f. The gears are damaged or not.
- g. Check seal and see if there Is oil leakage or not.
- h. Never dismantle oil pump, it can not function well after dismantling.

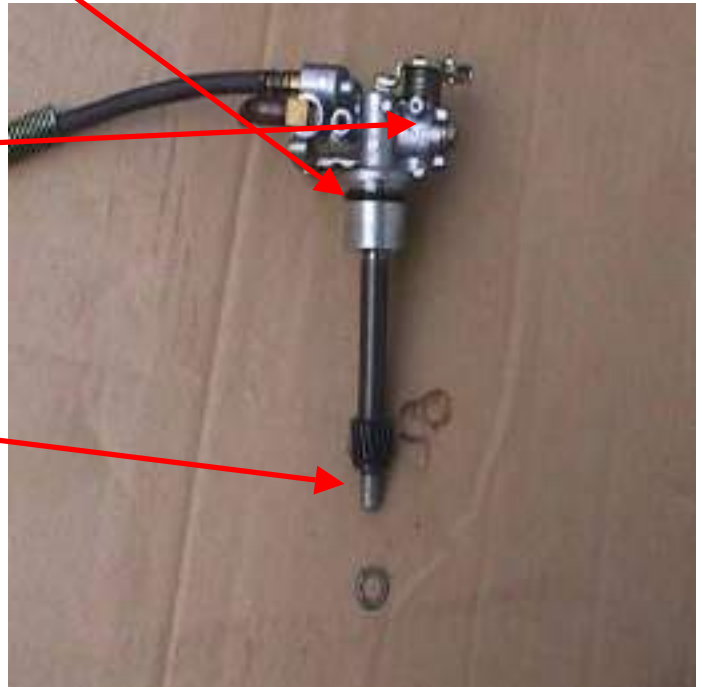



5. Assemble the oil pump.

- a. Assemble the oil pump by reversing above procedure.

O-ring of oil pump should be lubricated by grease or oil, then place on crankcase.  
The contact surface of oil pump and crankcase should be assembled firmly.  
The gears of oil pump should be lubricated by grease.

- b. Be sure oil pump screw is tightened.

After assembling, check the following:

- a. the adjustment of control cables  
b. Is there air in oil pipe.  
c. oil leakage at any location.

6. Releasing air in the oil pump.

- a. If there is air in the oil pipe, it will cause engine lubrication trouble  
b. Releasing air operation means the release of air trapped in the air pipe and oil pump. Please firstly release air from the oil pipe

(a) Fill up specific amount of oil to oil tank.

(b) Place dry cloth under the oil pump.

© Remove oil pipe.

(d) Use injector to fill up the oil in the oil pipe and oil pump body . Be sure the oil pipe and oil pump are full of oil before assembling.

(e) After assembling check if there is still air trapped in the oil pipe.



### (3) Engine Dismantling

#### A. Dismantling engine.

1. Take off the luggage compartment.
2. Take off the left and right body covers.
3. Take off the lower mudguard fender.

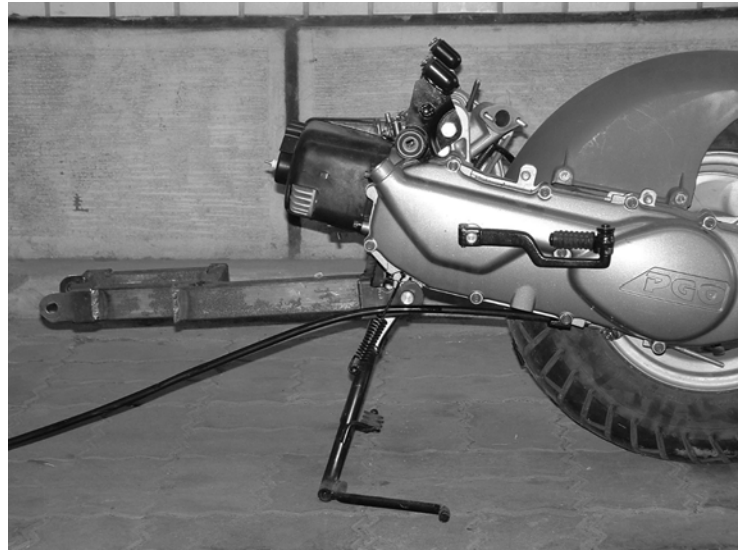

4. Remove vacuum pipe, fuel pipe, auto choke, cap of spark plug, rear Brake cable carburetor pipe, engine flywheel shelf's nut, starter Motor cable plate and rear damper bolt.

5. Remove the engine.

#### B. Installing Engine.

1. To install engine, please reverse the above procedures.

2. Locking torque:

M8: 2.0~3.0kg-m

M10: 3.0~4.0kg-m

M12: 5.0~6.0kg-m

3. After installing, please do the following checking and adjustment:

Checking and adjustment:

- a. Wiring connection.
- b. Throttle cable and oil control cable.
- c. Rear brake adjustment.
- d. Fuel and oil route.



#### (4) Drive pulley, starter & clutch

##### A. Troubleshooting:

- a. Engine starts, but vehicle does not move.
  1. driving belt worn out
  2. driven plate worn out
  3. clutch lining worn out
  4. driving plate's spring broken
- b. The vehicle stops or trembles when running,
  1. clutch lining spring cracked or broken.
- c. Can't reach high speed, no pick-up
  1. driving belt worn out.
  2. Driving plate spring distortion.
  3. Weight roller worn out.
  4. Driving plate abnormal.

Note:

No grease and oil allowed to stain on driving belt and driven plate.

##### B. CVT parts measurement data

Item	Standard value(mm)	Limit of use(mm)
Model	50cc	50cc
The inner dia. of Slide driving plate	20.035-20.085	20.123
The outer dia..of boss, movable Driving plate	19.960-19.974	19.911
Belt width	18.0-19.0	17.0
Clutch lining thickness	3	1.5
Clutch outer diameter	117.0~117.2	117.5
Driving plate spring, free length	87.9	82.5
The outer diameter of driven plate sets	33.965~34.025	33.95
The inner diameter of slide Driven plate	34.000~34.025	34.070
The outer diameter of weight Roller set	15.992~16.008	15.50

C. Driving pulley.

1. Take off the 10 screws of left Cover, remove the left cover.



2. Take off the left cover.



3.Remove the fixing nut of the clutch.

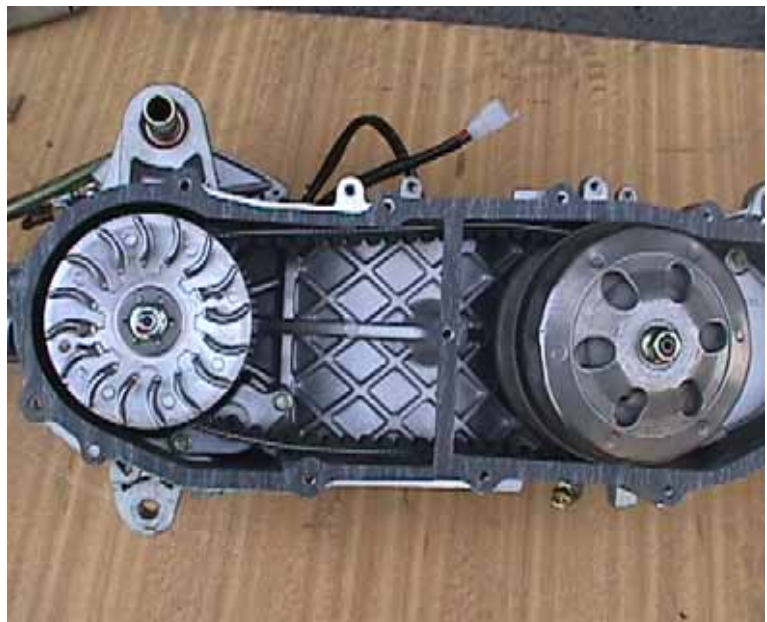

4.Take off the ramp plate.



5.Take off the belt and the rear clutch.

6.Take off the driving plate.

- Take off the driving gear start set.



7.Remove the start idle gear fixing plate.

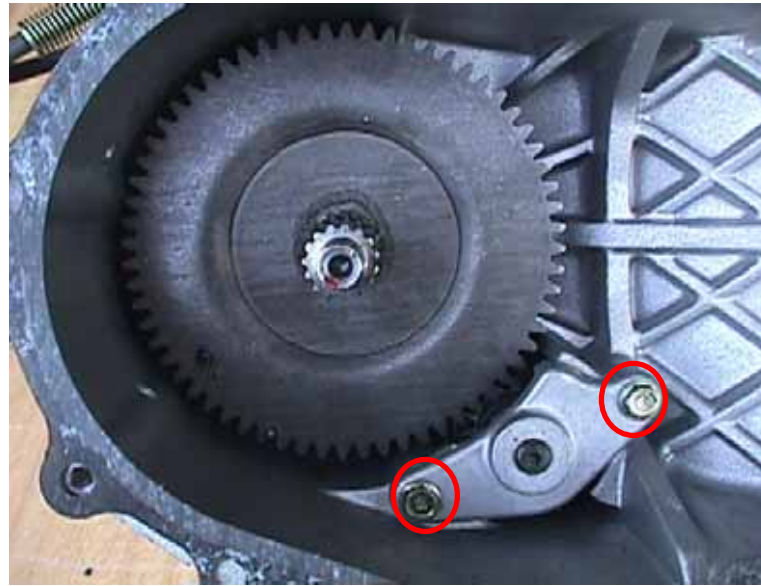

8.Take off the idle gear.



9.To assemble the driving pulley, please reverse above procedure.

Locking torque:

1.Nut of driving pulley:M10: 3.2~4.0kg-m

2.Locking nut of clutch:M10: 3.5~4.0kg-m

10.Checking the driving belt

(1)check whether it is cracked or not or its rubber and fiber are loose or not  
check also if they are extraordinarily worn out.

(2)driving belt width:

limit of use : change it below 17.0mm.

11. Disassemble the slide driving plate set

(1)Remove the bush of slide driving plate

(2)Remove the screw, and disassemble the cover  
of slide driving plate.

(3)Remove RAMP plate.

(4)Remove weight roller.

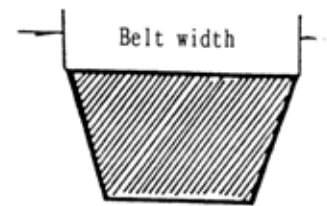

12.Checking list:

(1)Check the wearing condition of the weight roller.

limit of use:change it when below 15.5mm.

(2)Check inner dia of slide driving plate's gasket.

Limit of use:

50cc:Change it when above 20.123 mm

(3)Check the wearing condition for driving pulley surface.

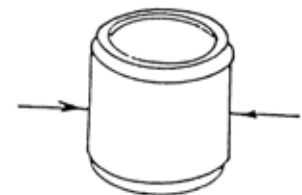

Check the wearing condition

(4)Check the outer diameter of the driving plate's boss.

Limit of use:

change it when below 19.911mm

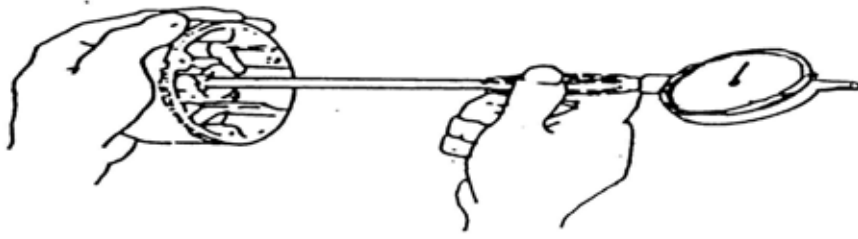

13. Assemble the slide driving plate.

- (1) Clean the inner surface of slide driving plate, then assemble the roller.
- (2) Assemble the ramp plate.
- (3) Please reverse the procedures of disassembling to finish assembling.



#### D. Starter dismantling

1. Dismantle the left crankcase cover
2. Remove the hexagon nut, then remove the starter lever.
3. Remove five screws of isolating plate.
4. Remove the stator spring from the start returning positioner.
5. Remove the driven gear comp of kick starter.
6. Remove the retaining c-type clip
7. Remove the spindle comp.

Of kick starter.

#### 8. Checking the starter

- a. Check the wearing condition of the outer diameter of the spindle comp and the inner diameter of bush and gear.
- b. Check the wearing condition of the shaft of driven gear comp, gear sets and ratchet.

#### 9. Assembling the starter

To assemble the starter, please follow the opposite procedures of dismantling.

Locking torque: M6:1.0~1.2kg-m

#### Note:

① Make sure that one end of the torsion spring is hooked on the groove of driven gear, and another end of the torsion spring is hooked on the pole inside the left crankcase.

② Put some grease on shaft and gear sets before assembling.



## E. Clutch driven pulley

### 1. Dismantle the clutch

- a. Remove left crankcase cover.
- b. Remove driving plate.
- c. Remove driving belt.
- d. Remove the M10 locking nut, then the clutch.

2. Assembling the clutch: please follow the opposite procedure of dismantling.

Locking torque:  
M10: 3.5~4.0kg-m

### 3. Checking the clutch:

Dismantling the clutch needs the special Tool. please contact your dealers.

- a. Check the clutch driven face.  
Check the clutch cover about its wearing Condition and inner diameter measurement.

Limit of use:  
50cc: Change it when above 117.5mm

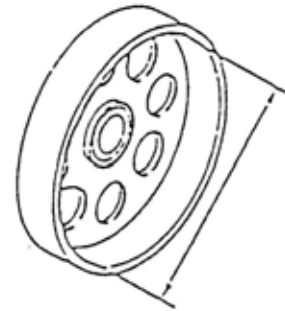

- b. Check the clutch lining wearing condition and measure the lining thickness  
limit of use: change it below 2.5mm.

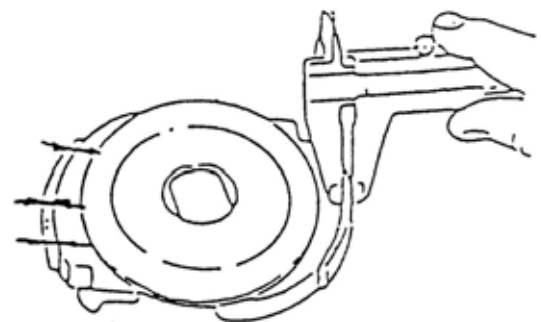

- c. Check driven spring free  
length: standard: 87.9mm  
Limit of use:change it as it  
Is below 82.5mm(50cc)

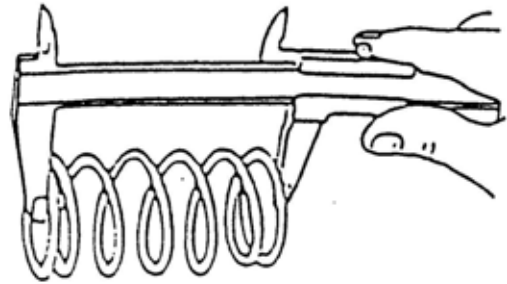

- d. Check wearing condition of  
driving plate set.  
Outer diameter measurement:  
Limit of use:change it as it  
Is above 33.950mm

- e. Check wearing condition of  
slide driven plate.  
Inner diameter measurement:  
Limit of use:change it as it  
Is above 34.070mm

- f. Check is there any wearing  
occur to the ditch.

- g. Check wearing condition of  
seal location, if necessary  
change a new one.

## (5)Cylinder and piston:

### A. Troubleshooting.

- a. compression pressure is too low, difficult to start engine and running unsmoothly.
  1. Cylinder head gasket cracked.
  2. Spark plug is not well-locked.
  3. Piston ring worn out or cracked.
  4. Cylinder, piston worn out.
  5. Reed valve is defective.
- b. compression pressure is too high, engine overheating or abnormal noise.
  - 1.piston tip has too much carbon piled up.
- c. Abnormal piston noise
  1. cylinder and piston worn out.
  2. Piston pin hole or piston pin worn out.
  3. Connecting rod small-end or bearing worn out.
- d. Abnormal piston or cylinder noise
  - 1.piston ring worn out or cracked.
  - 2.Cylinder worn out or cracked.

### B. The operation notice:

- 1.clean before operation to avoid particles dropping into engine.
- 2.The connect surface of gasket must be clean.
- 3.Dismantle the cylinder and the cylinder head by screw driver.  
Do not scratch the contact surface.
- 4.Cylinder inner surface and piston outer surface can't be scratched.  
The contact surface should be lubricated by specified oil.

### C. PISTON & CYLINDER DATAS:

Part name/description		Standard Value (mm)	Limit of use (mm)
Cylinder head	Flatness		0.100
cylinder	Bore	39.995~40.015	40.050
Piston/ Piston ring	Clearance b/w Piston ring piston and	Lst ring	0.05~0.06
		2 <sup>nd</sup> ring	0.05~0.06
	Piston outer diameter	39.950~39.970	39.895
	Measuring location of piston outer dia. (12mm from the lower end of skirt)		
	Clearance b/w piston and cylinder	0.045~0.065	0.10
	Piston pin hole inner dia	13.022~13.013	13.045
Piston pin hole inner diameter		10.002~10.008	10.025
Piston pin outer diameter		9.994~10.000	9.970
Clearance between piston and piston pin		0.004~0.018	0.030
Connecting rod small end inner dia		13.996~14.007	14.025

## D. cylinder head, cylinder, and piston dismantling.

- 1.Remove the engine.
- 2.Screwing out the two M6-bolt of cooling cowl.
- 3.Screwing out the two M6-blot of fan cover.



- 4.Remove the cooling cowl and fan cover.

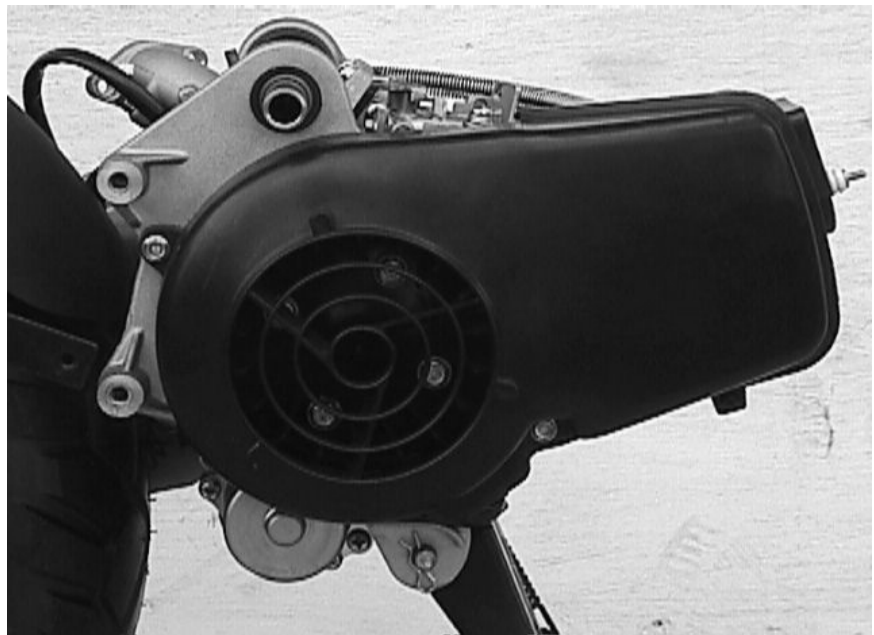

5.Remove the spark plug.

6.Remove the two M6 nuts on the muffler and cylinder.

Also remove the two M8-bolt of crankcase.

7.Remove muffler.



8.Remove the four M7-nut on the cylinder head, then remove the cylinder head and cylinder head gasket.

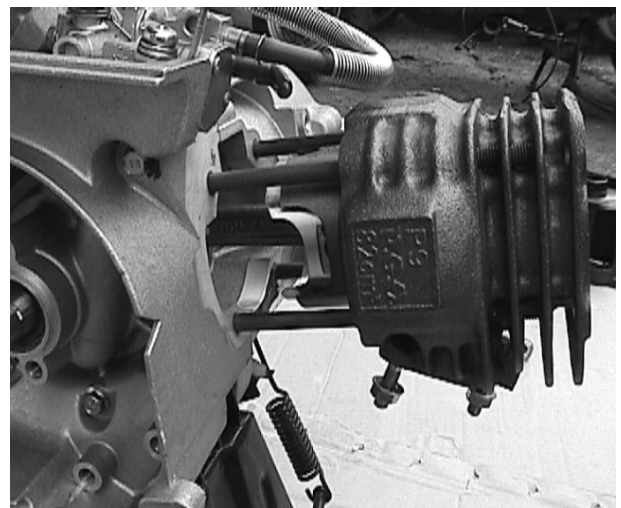
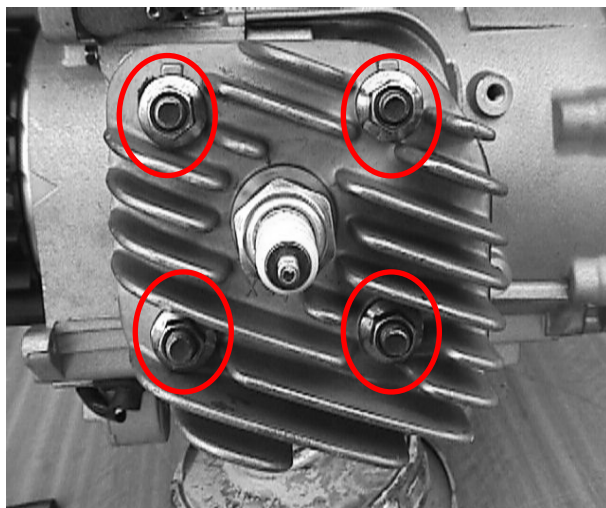

9.Remove the Cylinder and the gasket.

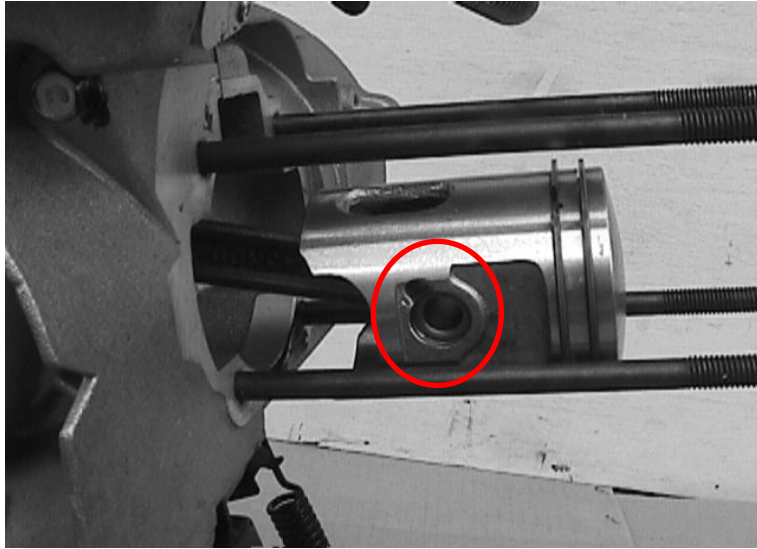

10.Remove the c type clip on the piston and piston pins by the nipper.

- Take off piston.

11.Dismantling of the piston ring Take off the first piston ring then the second ring.

12.When assembling please reverse the procedures of dismantling.

Locking torque: M7:1.0-1.4kg-m M6:1.0-1.2kg-m
-----------------------------------------------------

Opening end of piston ring

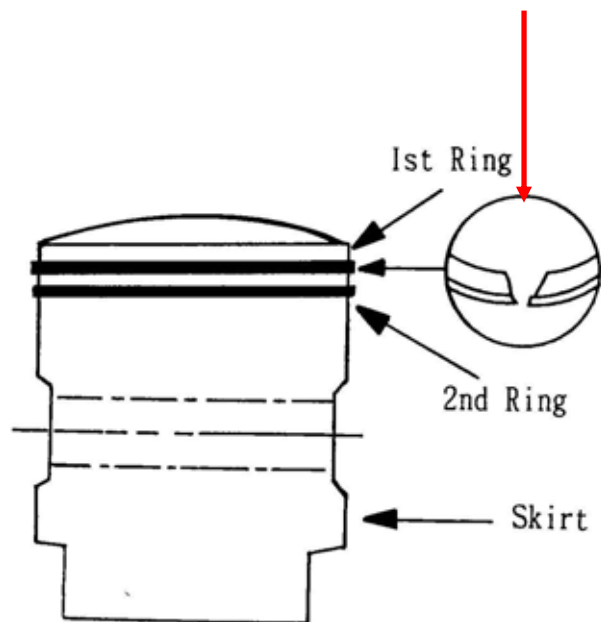



## (6)A.C. Generator, Flyweel

### A.Dismantling AC generator

- 1.Remove fan cowl.
- 2.Remove the M6 screws(4)
- 3.Remove Screws of flywheel magneto
- 4.Remove the AC flywheel magneto by special tool.

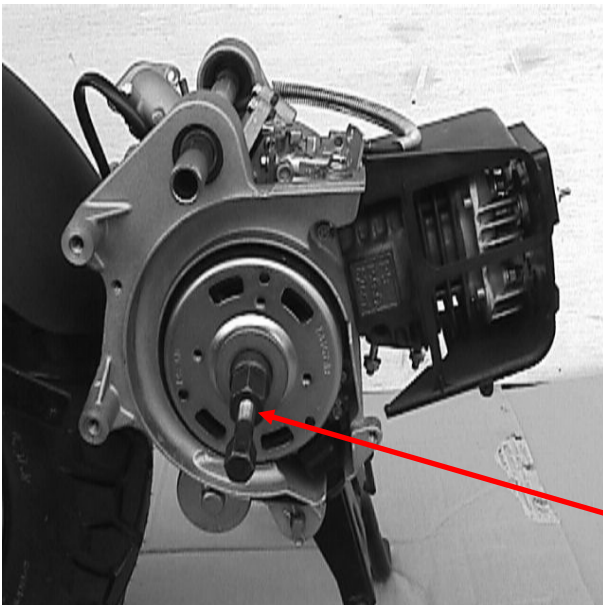
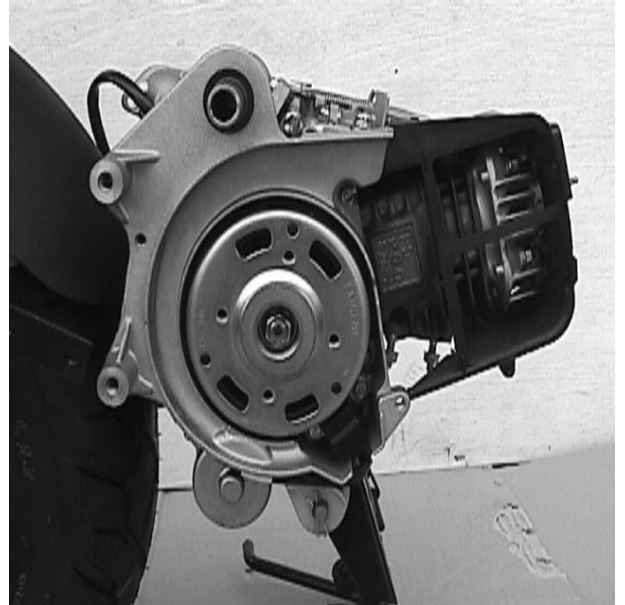
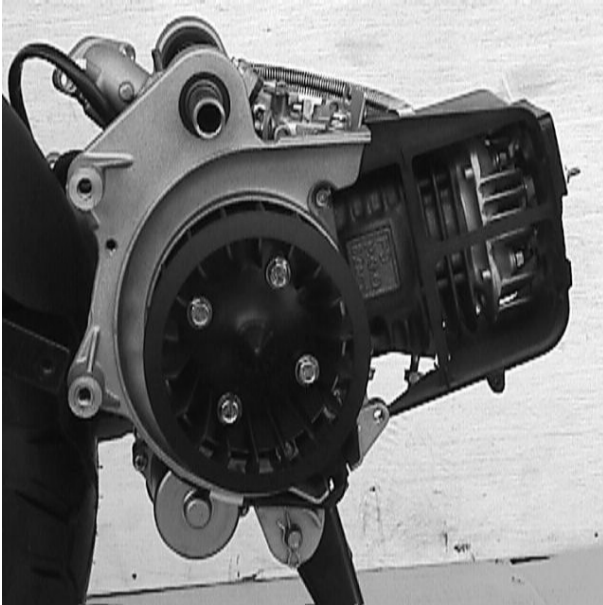



5.Remove the flywheel.

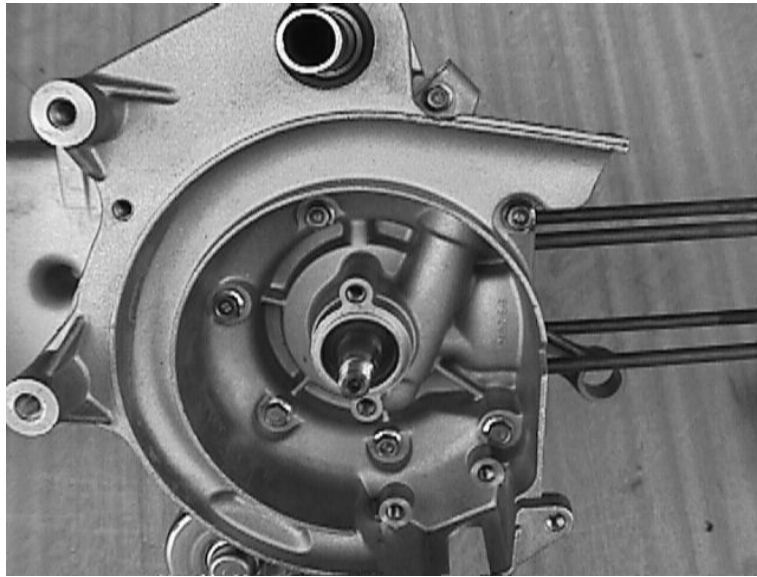

6.Remove the electric plug of AC Flywheel magneto.  
Take out the magneto.

## **B. Install AC generator**

To install, please reverse the dismantling procedures.

Locking torque:  
M6: 1.0~1.2kg-m  
M10: 3.2~4.0kg-m

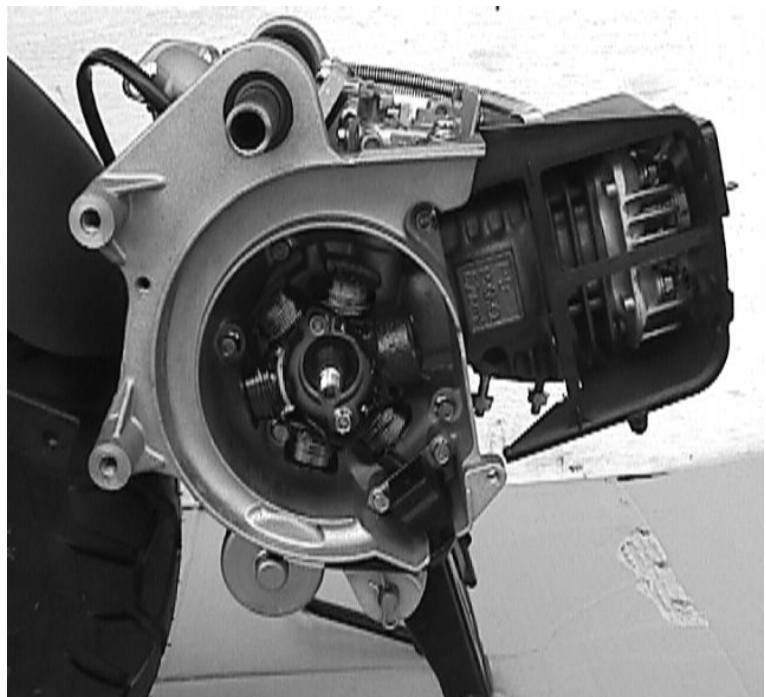

## (7)Final Transmission Mechanism

### A. Trouble shooting

- Engine can be started, but vehicle doesn't move.

- 1.Gear worn-out or cracked.
- 2.Gear burnt out.

- Noise occurs when running.

- 1.Gear worn out, burnt or gear surface damaged.
- 2.Bearing worn out or loosen.

- Oil leakage

- 1.Too much oil.
- 2.Seal worn out or damaged.

### B. Disassemble the final transmission mechanism.

- 1.Remove the rear wheel.



- 2.Drain off the oil in the gear box.

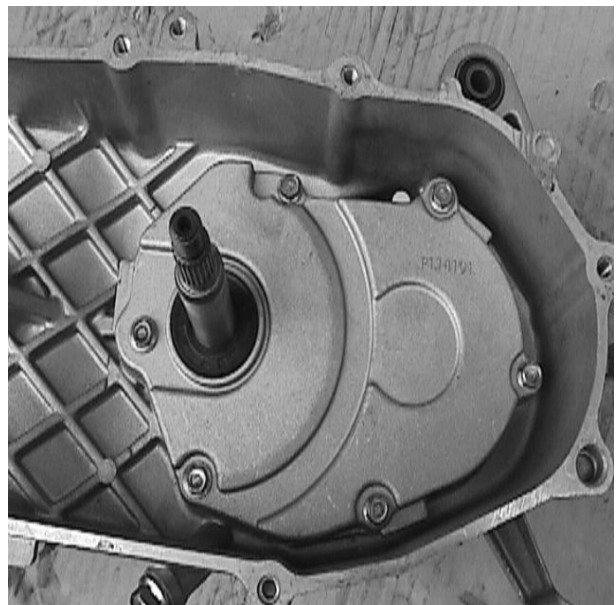

3.Remove the 6 bolt in gear box cover

4.Take off the gear box.

5.Take out the final reduction gear and idle gear shaft.

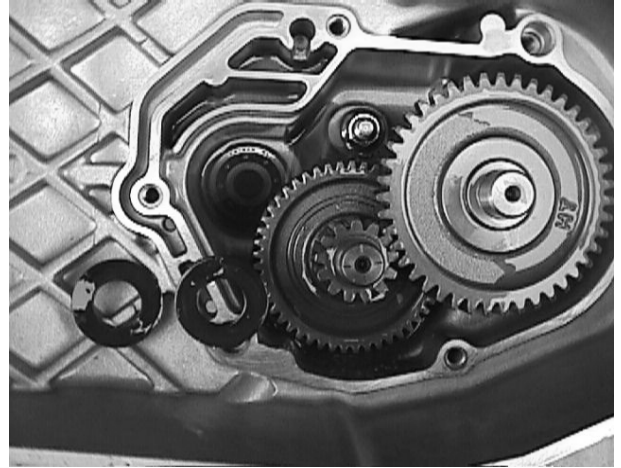
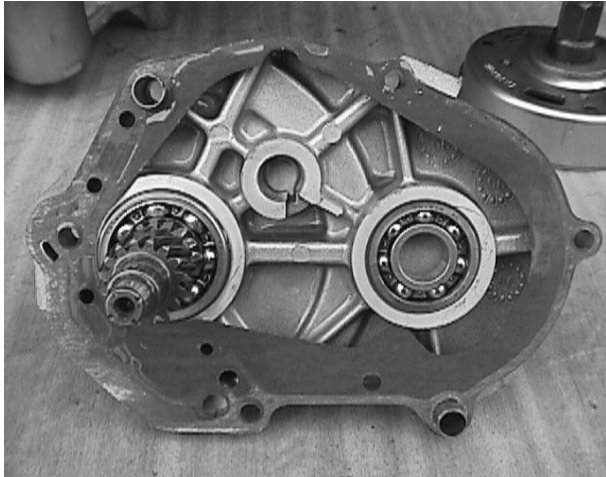

6.Clean up the gear box

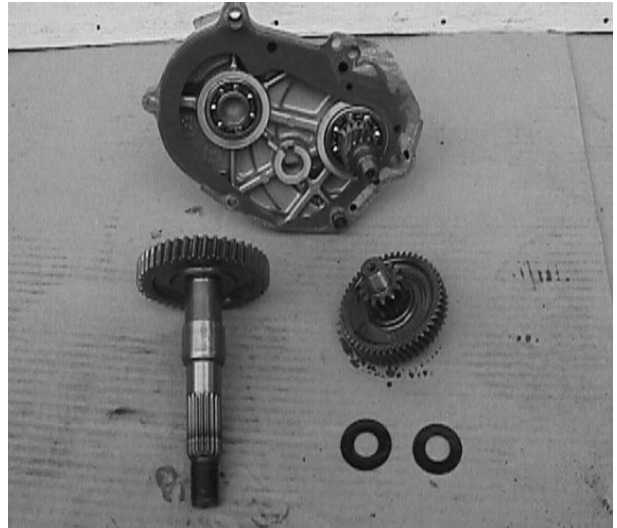

C. Check the final transmission mechanism

1. Check the wearing condition of the driving shaft and gears.

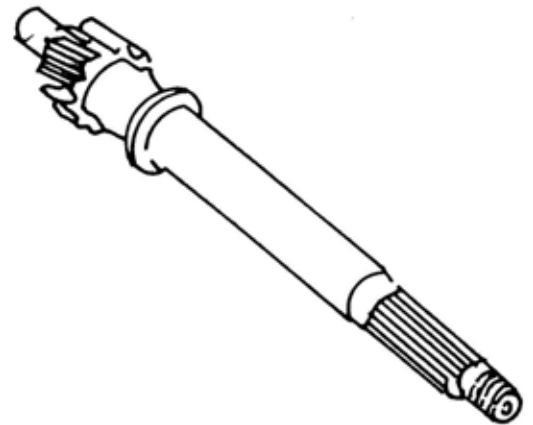

2. Check the wearing condition of the idle gear shaft and idle gears.

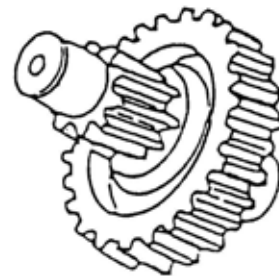

3. Check the wearing condition of the final reduction gear.

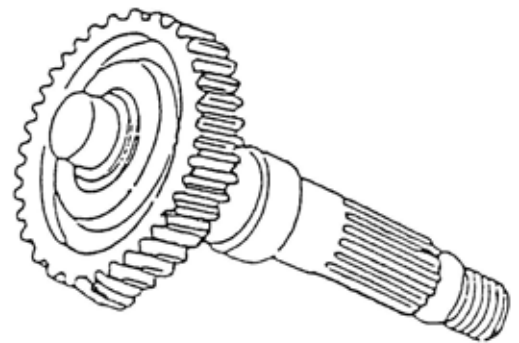

4. Check the wearing condition of the oil seal and bearing.

**D. Assemble the final transmission mechanism: please follow the opposite procedures Of disassembling. After locking the drain bolt, refill 90c.c of gear oil, SAE 85W/140.**

Locking torque: M6: 1.0~1.2 kg-m
M10: 3.5~4.0 kg-m
Drain bolt:        M8: 1.8 kg-m

### **E. Check for the flatness of cylinder head & cylinder.**

Check the flatness of contact surface of cylinder head & cylinder.

Limit of use: If it exceeds 0.1mm  
Change a new one.

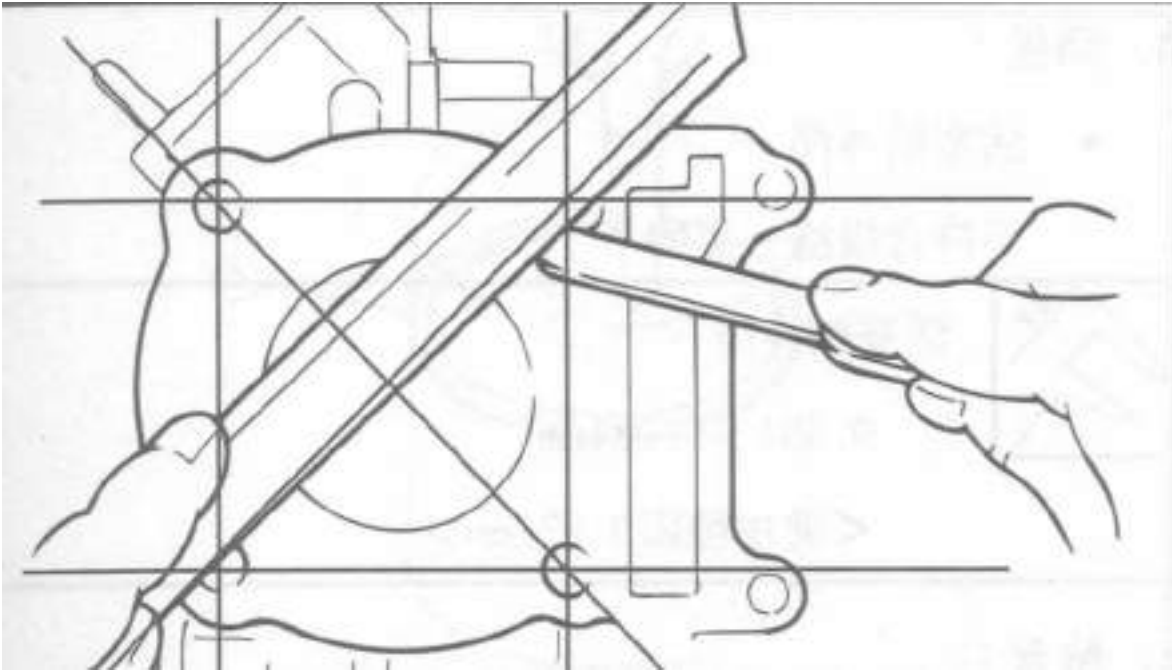

### **F. Combustion chamber cleaning**

- Clean out the carbon piled up in combustion chamber.
- Do not scratch the combustion chamber and contact surface of the cylinder during cleaning operation

## G. Check cylinder and piston:

1. Check the wearing and damage condition on the contact surface of the cylinder and piston.
2. Clean out the carbon on the cylinder exhausting port.

Be careful not to scratch the inner surface of cylinder.

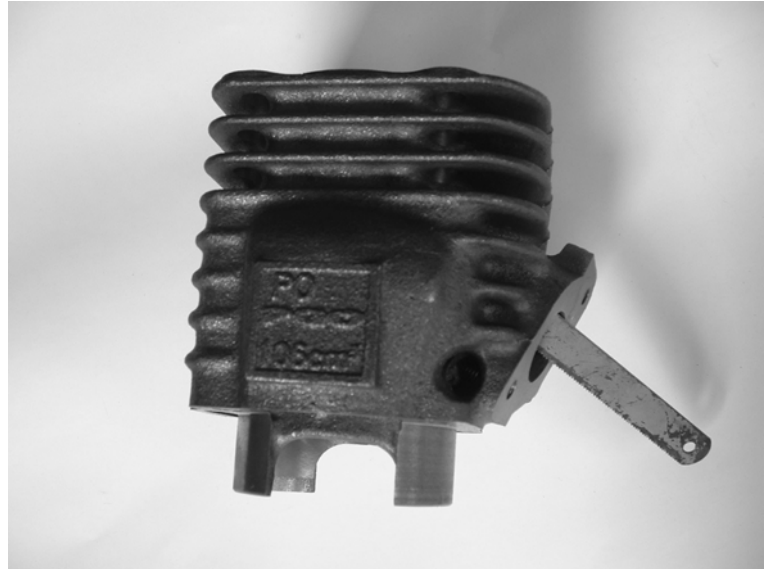

### 3. Cylinder bore measurement:

- (1) Measure each point (A)(B)(C) orderly, and in X.Y. axis to find the smallest value.
- (2) Limit of use: 50cc-change it when over 40.050mm

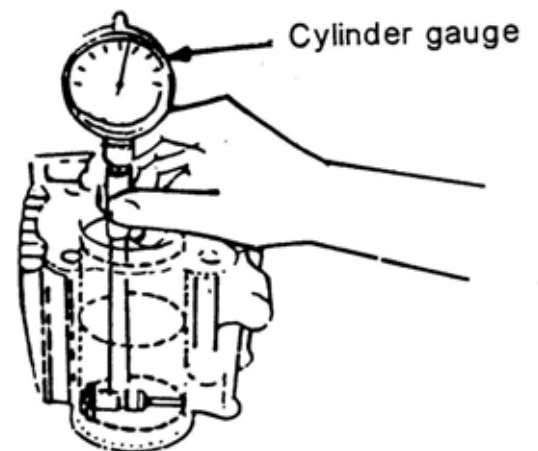
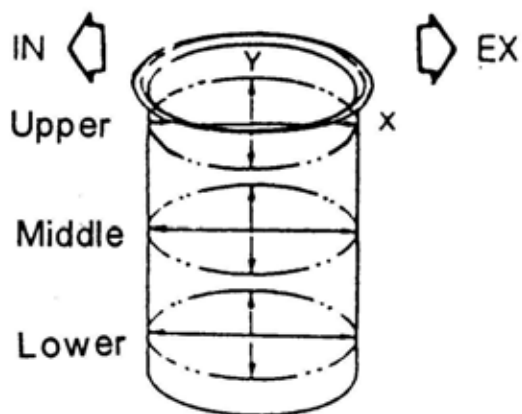

4. Piston outer diameter measurement:

(1) Measure at the skirt area where is 12 mm from the skirt lower end of skirt.

(2) Limit of use: 50cc-change if when below 39.895mm



(3) Calculate the clearance between the cylinder and piston.

Limit of use: change it when over 0.100mm

5. Inner diameter measurement of the piston pin hole

Limit of use: change it when over 14.032mm

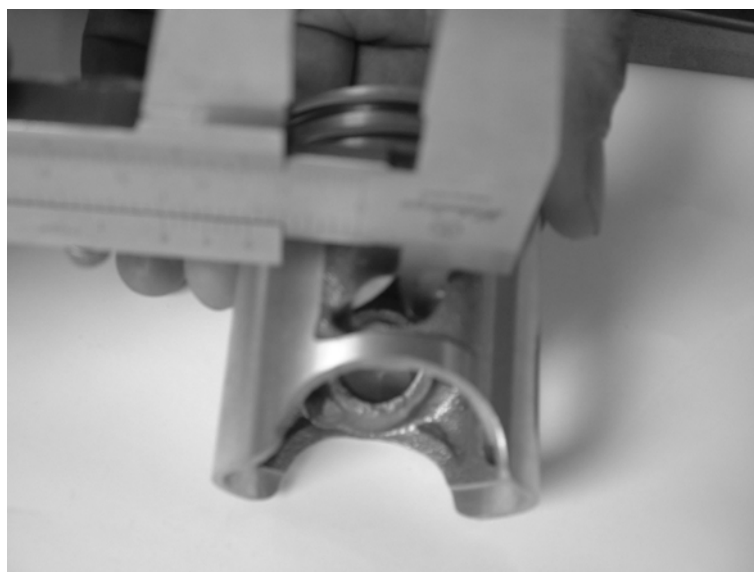

## 6. Outer diameter measurement of the piston pin

limit of use: change it when under 9.970mm(G-MAX 50cc)

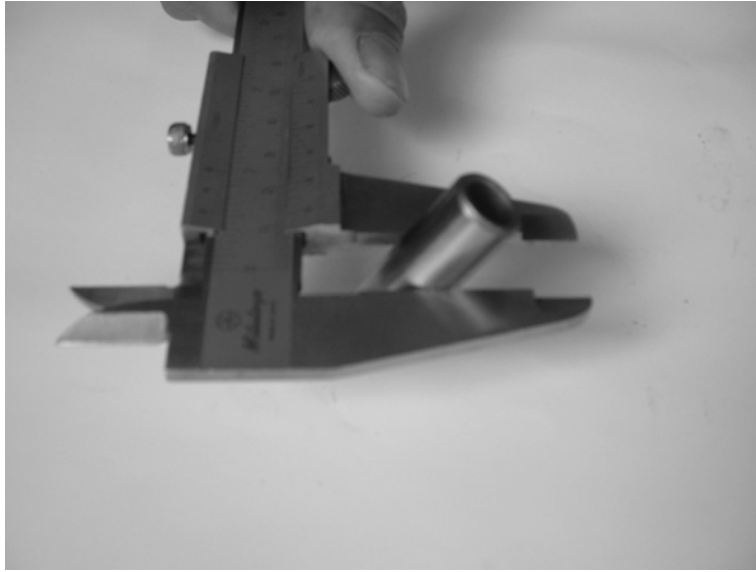

## 7. Check piston ring:

Measure piston ring gap:

Limit of use: change new ones when the first ring and second ring are over 0.4mm

Push the piston ring into the cylinder  
By piston, the measure the gap





## 8. Check connecting rod small end

- (1) Install piston pin, bearing onto the connecting rod small end, then check the looseness of the piston pin.
- (2) Measure the inner diameter of the connecting rod small end.

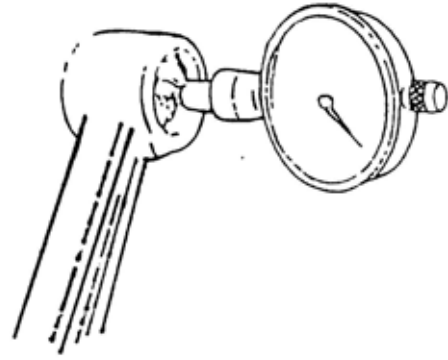

Limit of use: replace a new one when over 14.025mm.(G-MAX 50cc)

## H. Installing cylinder and piston

1. Place the piston ring into the second ring ditch first, then install the piston ring into the first ditch.
2.
  - a. Piston ring should be installed into piston ring ditch by even force
  - b. After assembling, be sure that the piston ring sliding surface is at the same height as the piston outer surface.
  - c. If the piston ring can not fit into the ditch, please clean up the carbon in the piston ring ditch or piston ring itself.
3.
  - a. Piston ring must be installed in the correct location.
  - b. After installing the piston ring, it should be able to rotate freely.
  - c. If it is necessary to change the new piston ring, it must change the whole set.
4.
  - a. The location of the piston ring gap and the lock pin must be in opposite side.
  - b. The mark "→" on the piston tip must be pointing to the exhausting port.
  - c. Lubricate the piston pin before installation.
5. Please follow the opposite procedure of dismantling to install cylinder and cylinder head.

**(8)Crankcase, Crankshaft:**

A. Disassembling diagram

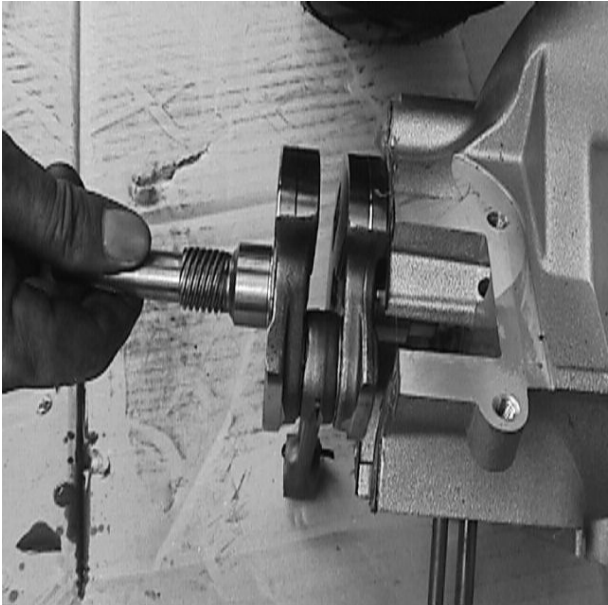
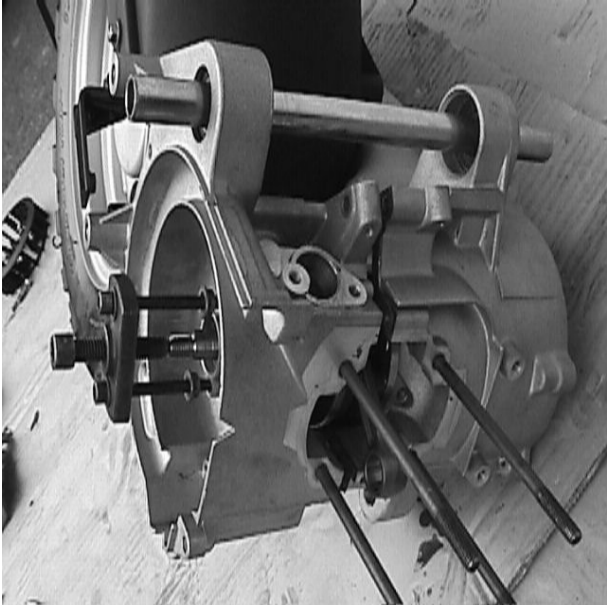
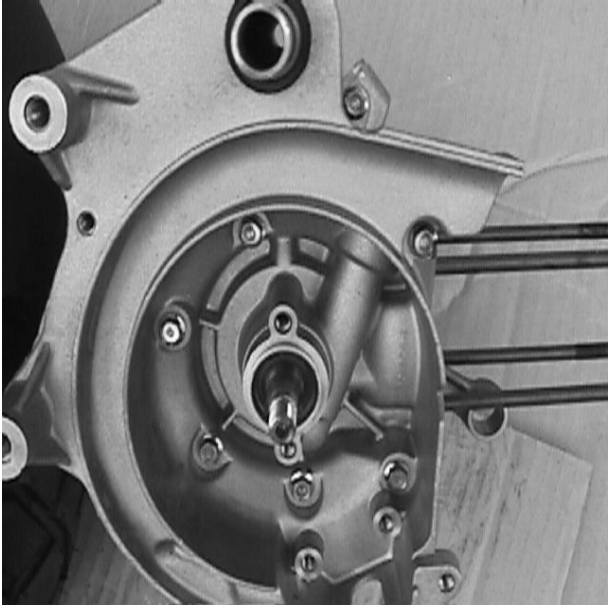

## B. Troubleshooting.

Engine noise:

- 1.The bearing of final transmission mechanism is loose.
- 2.Crank pin bearing is loose.
- 3.The bearing of gear box is loose.

## C. Data

Measuring Item	Standard value	Limit of use.(mm)
Clearance of connecting rod big end (Parallel direction to rod)	0.20-0.50	0.71(50cc)
Clearance of connecting rod big end (Perpendicular direction to rod)	-	0.04
Swingness of the crank shaft neck	0.03	0.10

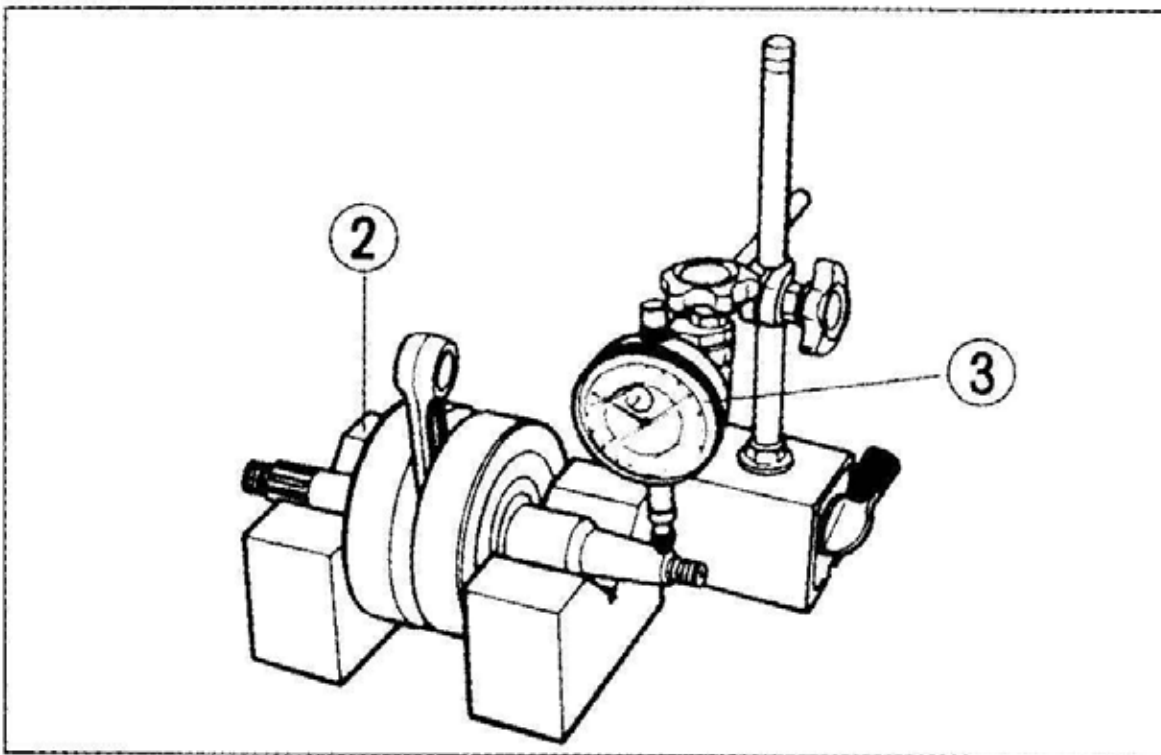

D. Dismantle the crankcase and crankshaft please follow the following procedures:

1.Remove the engine.



2.Remove the left crank case, the driving pulley (driving plate) clutch and belt.

3.Remove the air cleaner.

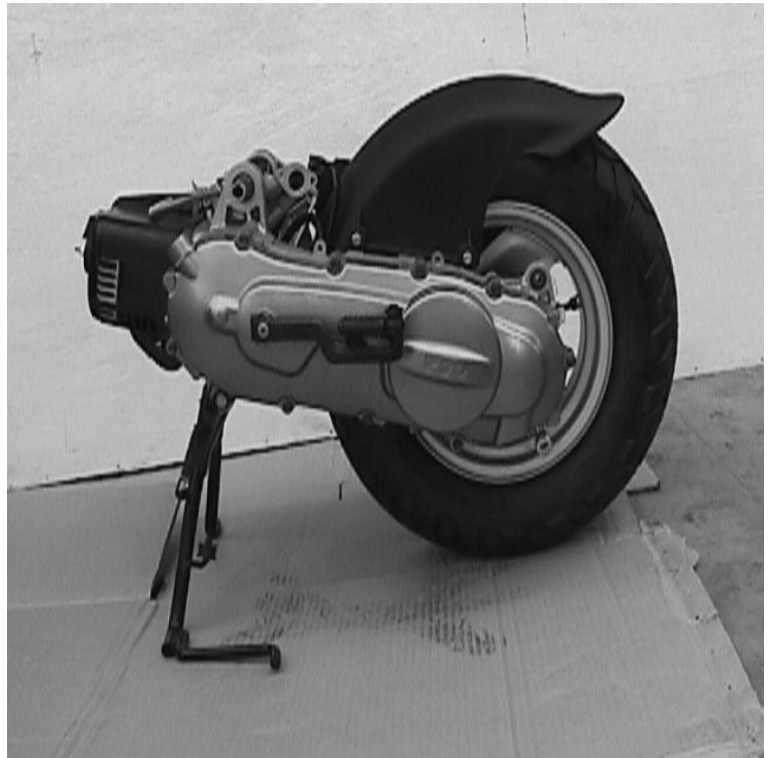

4.Remove the carburetor.

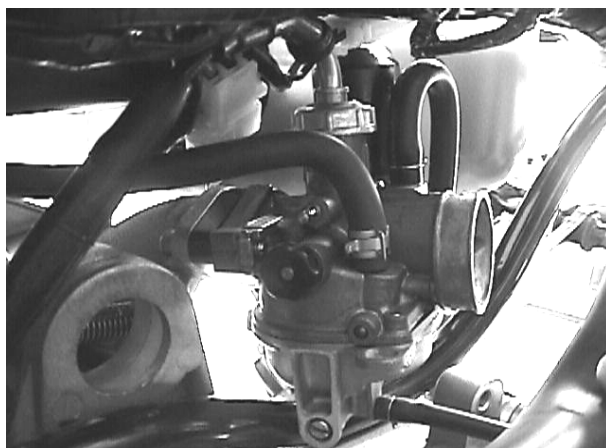

5.Remove the intake manifold and reed valve.

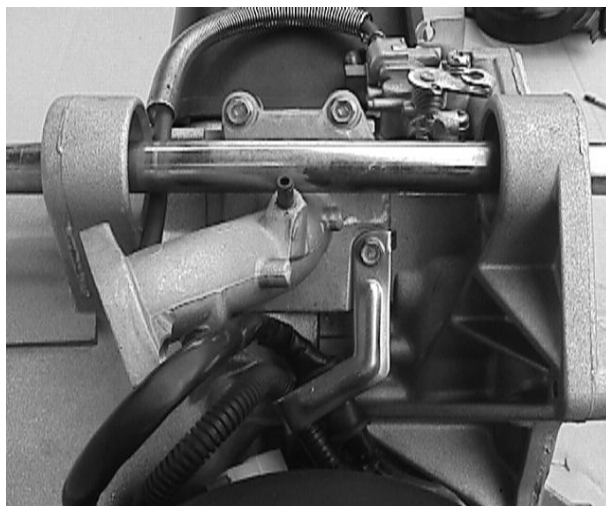

6.Remove the oil pump, fan cowl and fan itself.

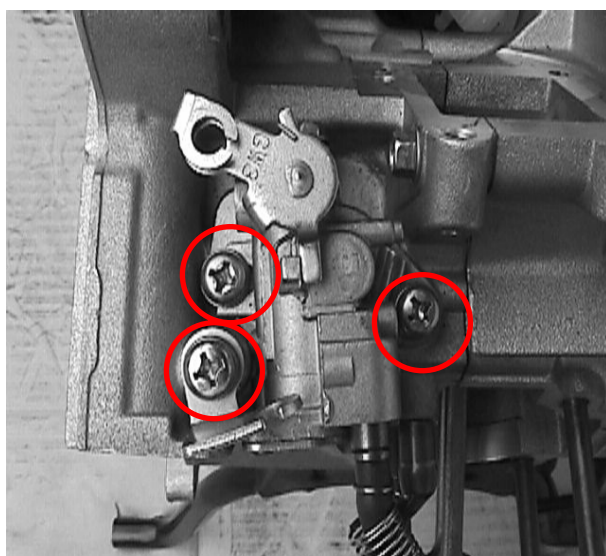

7.Remove the AC flywheel magneto.



8.Dismantle the right and left crankcase.  
There are all together 7 bolts.

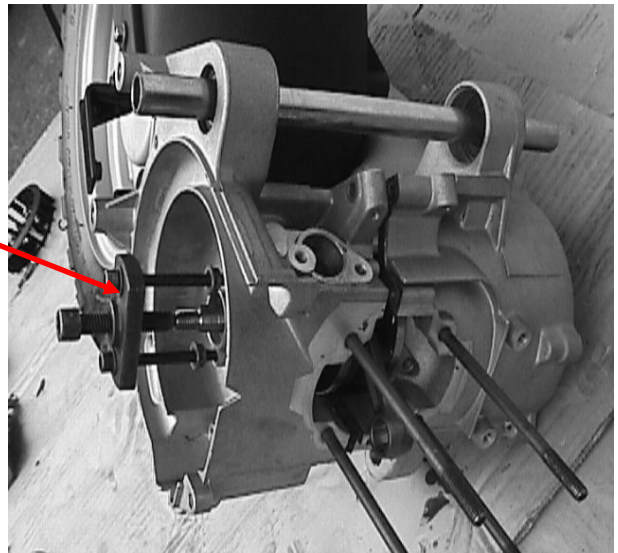

9.Remove center stand, left and right crankcase and take out the crankshaft.

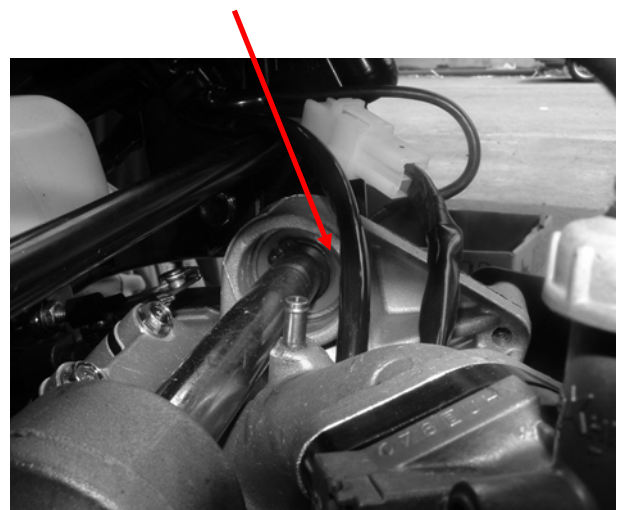
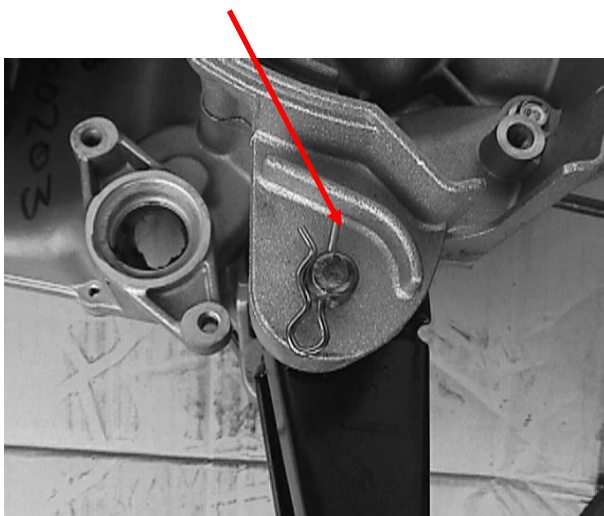

E. Check the crankshaft:

1. measure the clearance between crank shaft and co-rod big end. (Parallel direction to rod)

Limit of use: Replace a new when above 0.71mm

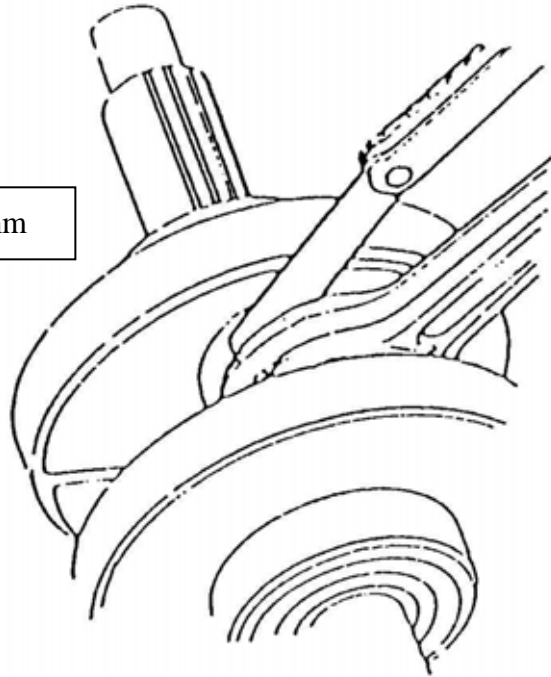

2. check the looseness on X.Y. axis of the connecting rod big end (Perpendicular directions to rod)

Limit of use: Replace a new one when above 0.04mm

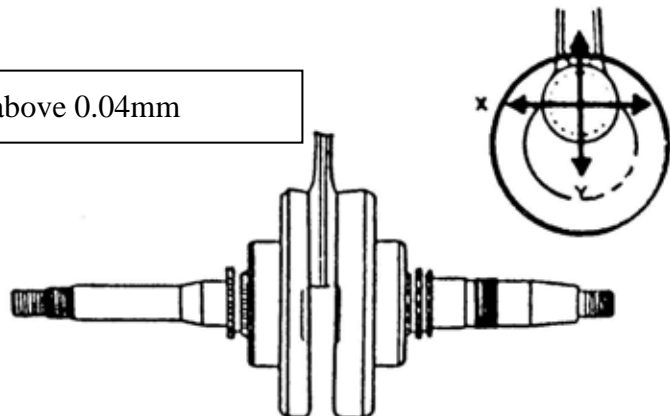

3. measure the swingness of crank shaft neck.

Limit of use	
A	B
Change it when Above 0.1mm	Change it when Above 0.1mm

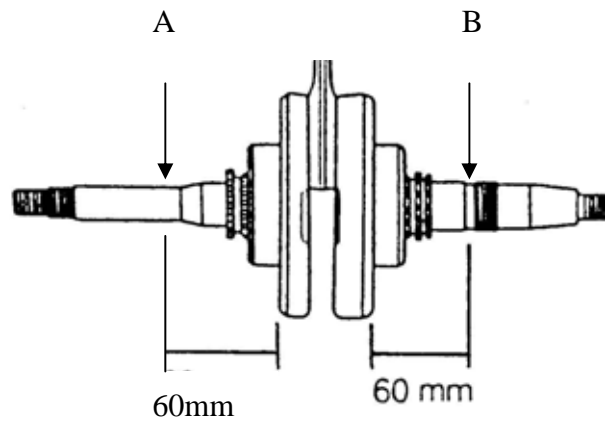

4. check the slackness of crankshaft bearing,  
if it is slack, change a new one.

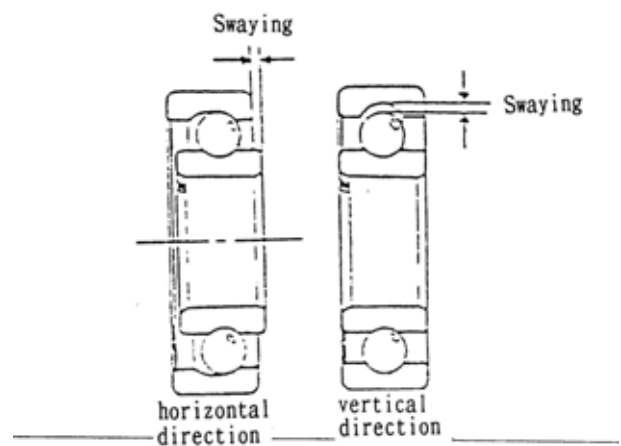

F. Assemble the crankcase.

1. To assemble the crankcase, please reverse the procedures of disassembly.
2. The locking torque value for bolts and nuts are all described in the previous chapters. Please refer.



## (9)Carburetor, Reed Valve

A: Carburetor dismantling diagram

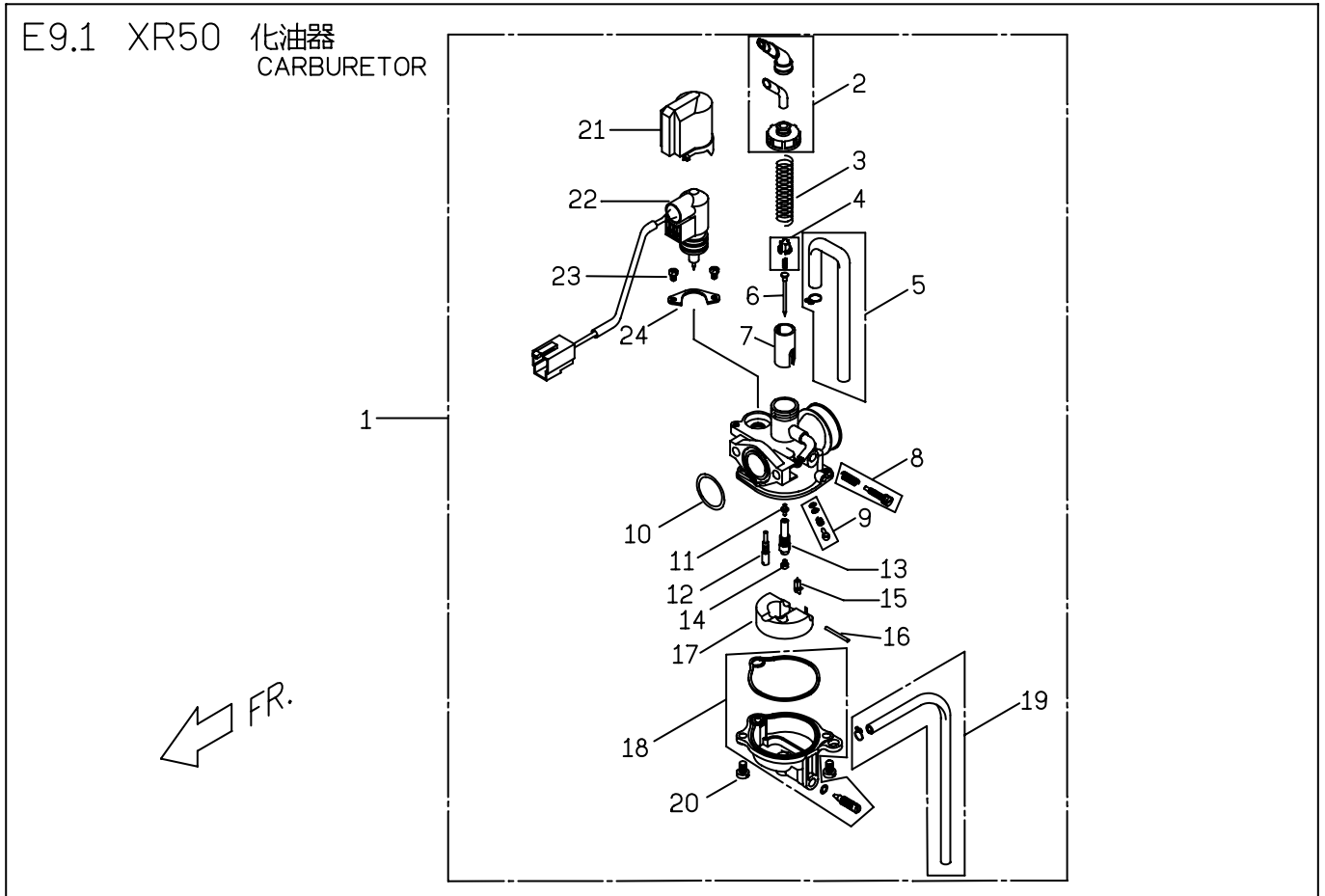

- 01 CARBURETOR ASSY.
- 02 TOP SET
- 03 SPG., COMP.
- 04 PLATE SET
- 05 TUBE SET
- 06 JET NEEDLE
- 07 THROTTLE VALVE
- 08 SCREW SET
- 09 SCREW SET (A.S)
- 10 O RING
- 11 NEEDLE JET
- 12 SLOW JET

- 13 HOLDER, NEEDLE JET
- 14 MAIN JET
- 15 FLOAT VALVE SET
- 16 PIN, ARM
- 17 FLOAT SET
- 18 FLOAT CHAMBER SET
- 19 TUBE SET
- 20 "SCREW, WASHER"
- 21 CAP HOLDER
- 22 AUTO BYSTARTER SET
- 23 SCREW, WASHER
- 24 PLATE SET

B. Troubleshooting:

a. Engine can not be started.

- 1.No fuel in the fuel tank.
- 2.Fuel pipe is blocked.
- 3.There is too much fuel in the cylinder.
- 4.Air cleaner is blocked.

b. Engine idling(RPM) unsteady, running not smoothly

- 1.Improper adjustment of the carburetor idling.
- 2.Ignition disorder.
- 3.Compression pressure is too low.
- 4.Air mixture is too thick.
- 5.Air mixture is too lean.
- 6.Air cleaner is blocked.
- 7.Air injection is not in good function.
- 8.Fuel is dirty.

c. Air mixture is too lean.

- 1.Carburetor main jet is blocked
- 2.The ventilation hole of the fuel tank cover is blocked.
- 3.Fuel filter is blocked.
- 4.Fuel pipe bended, squeezed or blocked.
- 5.Float valve is abnormal.
- 6.Fuel level is too low.
- 7.Air pipe is blocked.

d. Air mixture is too thick

- 1.Float valve is abnormal.
- 2.Fuel level is too high.
- 3.Air jet is blocked.

### C. Dismantling carburetor

- 1.Remove the luggage box.
- 2.Loose the hose clamp between the carburetor and the air cleaner.  
Then remove the air cleaner.
- 3.Unscrew the fuel draining screw of the carburetor. Drain off the fuel inside the carburetor.
- 4.Remove the fuel pipe and the vacuum pipe on the carburetor.
- 5.Remove the oil pile on the carburetor.
- 6.Remove the bolts on the intake manifold and carburetor.



### D. Dismantling float, nozzle

**Note:**

The auto choke has been properly adjusted already. Please do not adjust it further.  
When there is blockage in the carburetor, please clean it by air compressor.



## E. Reed valve

### 1. Dismantling reed valve.

- (1) Take off the luggage box
- (2) Remove the air cleaner
- (3) Remove the carburetor.
- (4) Unscrew the locking screw of the intake manifold.

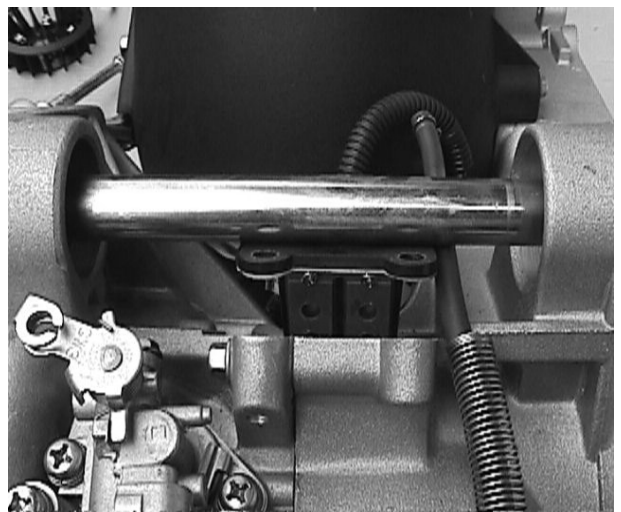
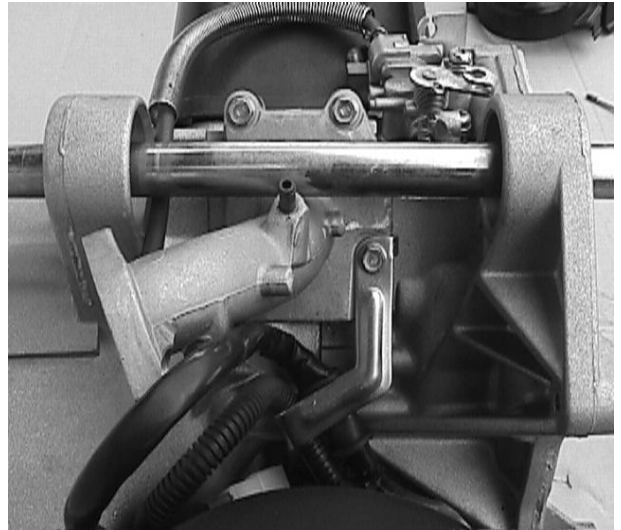

- (5) Remove the intake manifold.

- (6) Remove the reed valve.

### 2. checking for the reed valve.

- change a new one when the reed valve is worn out or distorted.
- change a new one too when the base of the reed valve is cracked, injured or distorted.

#### **4. G-MAX 125/150 engine Dismantling, Maintaining, Repairing and assembling operation**

- (1) Lubrication system
- (2) Engine dismantling
- (3) Drive pulley, starter, clutch, driven pulley
- (4) Cylinder head and valve
- (5) Cylinder and piston
- (6) AC generator
- (7) Final transmission mechanism
- (8) Crankcase, crank shaft
- (9) Carburetor

## (1) Lubrication System

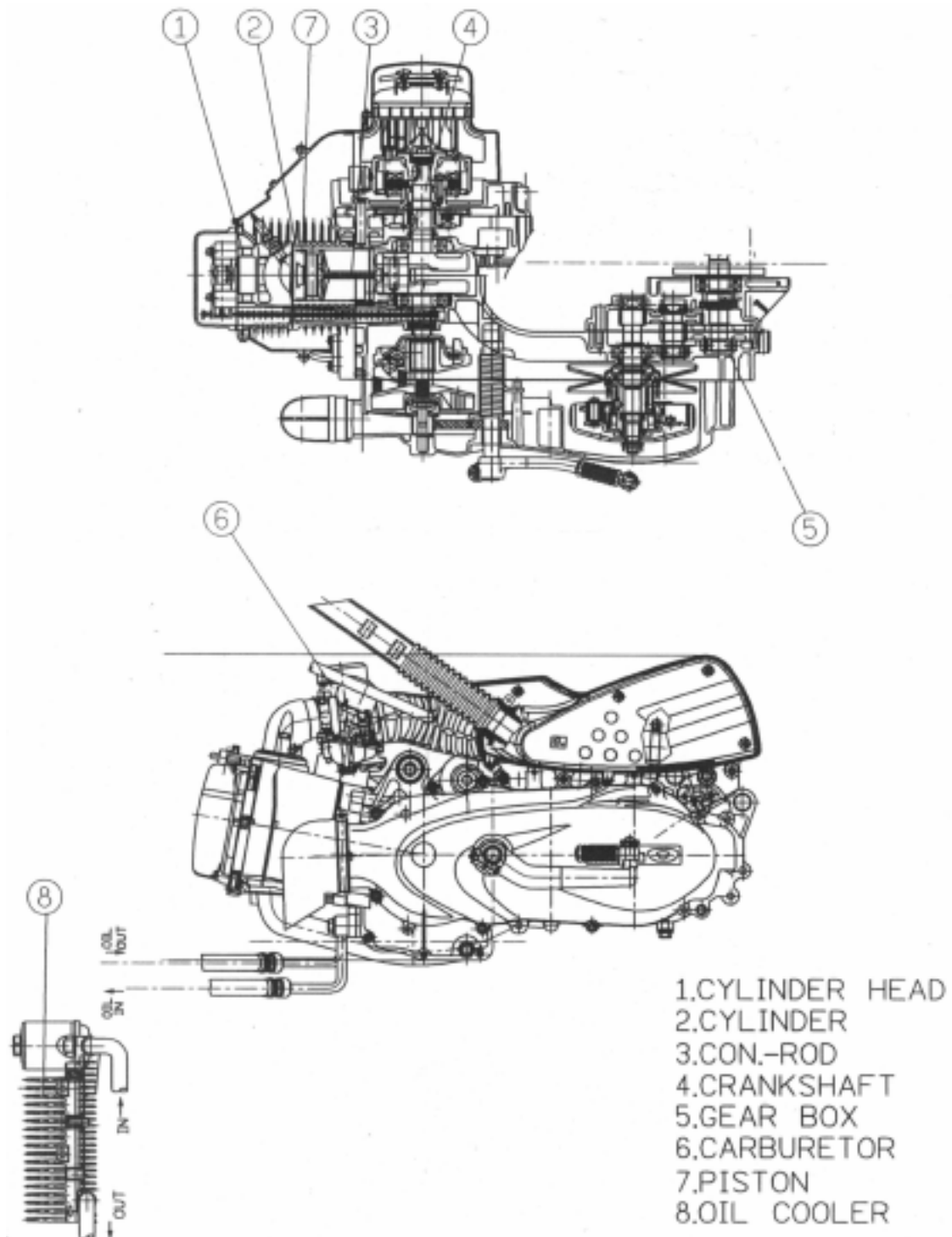

## ■ Oil Pump Dismantling

1. Remove the rear section of muffler.
2. Remove the AC flywheel magneto.

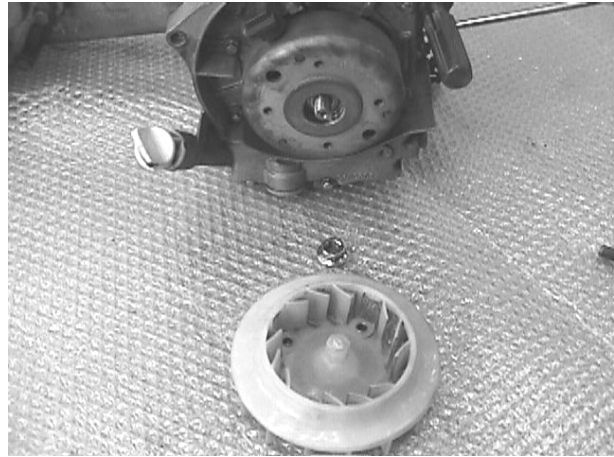

3. Remove the AC generator coil.
4. Take off the locking bolts of the right crankcase cover.
5. Remove the crankcase cover

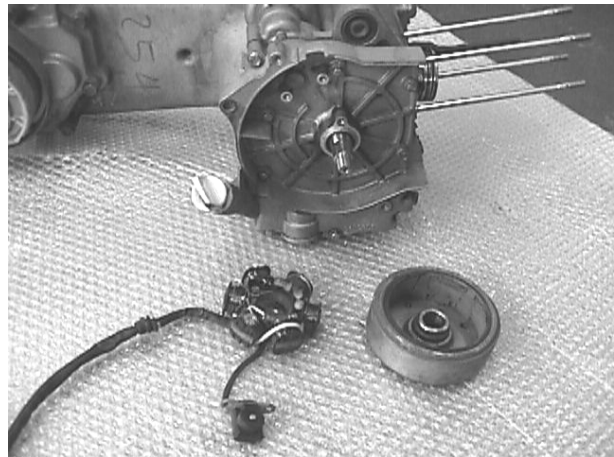

6. Remove the washer, lock pin
7. Remove starter reduction gear and the starting clutch.

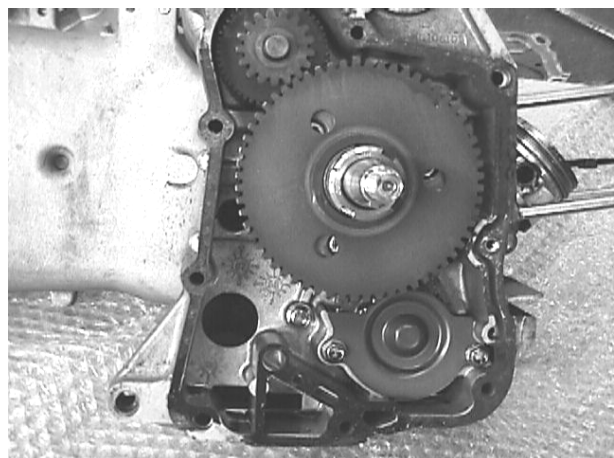

8. Remove oil pump separate plate by taking off the 2 bolts.
9. Remove the bolts from oil pump driving gear
10. Take off the driving gear and chain.
11. Remove the oil pump by taking off the locking bolt of the oil pump.

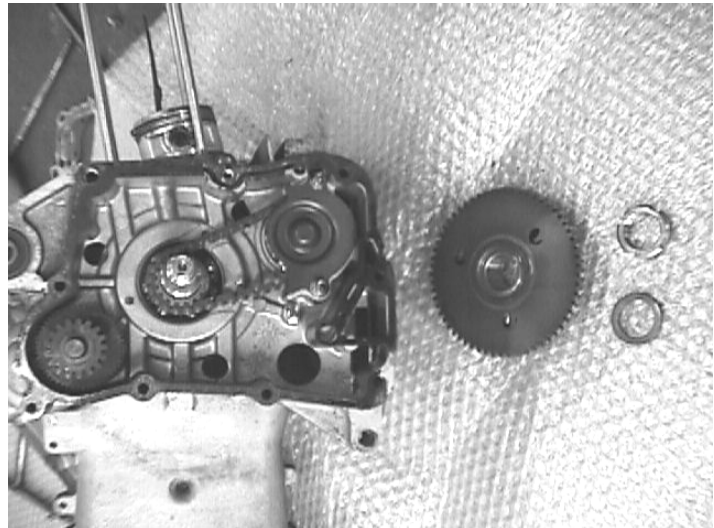

### ■ Oil pump Assembly

1. Install the inner and outer of the oil pump.
2. Install the oil pump shaft.

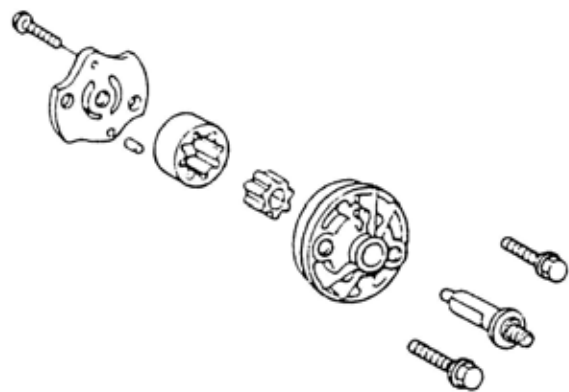

Note:  
The notch of the oil pump shaft should comply With the notch of the inner gear.

3. Install the lock pin.
4. Match the lock pin hole to the pump cover and install the oil pump cover.
5. Put on the screws and tighten them.
6. After installing, turn the shaft lightly to assure installation.
7. Place the oil pump into the crankcase.

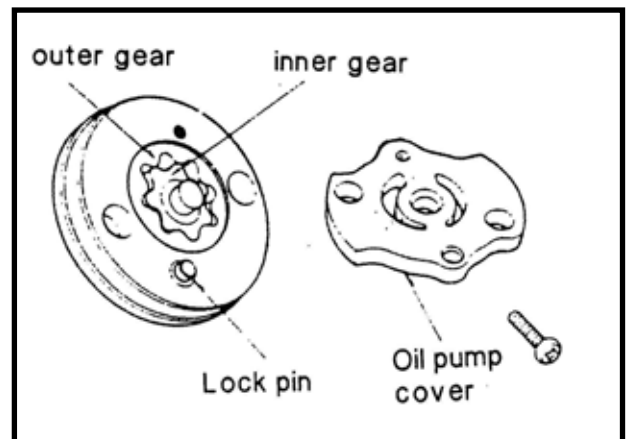

Note:  
When installing, the arrow on the oil pump body should be pointed upwards. Then fill in the recommended oil before the installation.

8. Tighten the oil pump after installation.

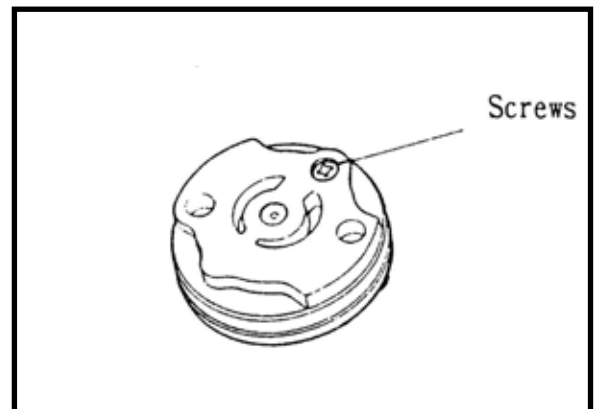



## Measurement data

item		Standard Value ( mm )	Limit of use ( mm )
Oil pump	Clearance between the inner gear And outer gear	—	0.12
	Clearance between the outer gear And oil pump body	0.045-0.10	0.12
	Clearance between gear end and Oil pump body	0.045-0.10	0.12

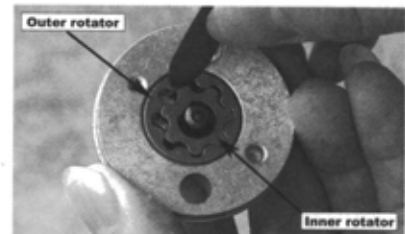
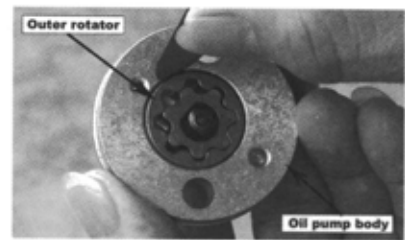

## Troubleshooting

### Reduction in fuel oil volume

- Natural consumption
- Leakage of fuel
- Piston loop seizes, or improperly installation
- Worn out of valve's oil seal

### Engine burning-out

- Zero or too low oil pressure
- Blockage in oil route
- Did not use the fuel oil recommended

## A. Dismantling engine

1. Take off the luggage compartment.
2. Take off the left and right body covers.
3. Take off the air cleaner fixing screws.



4. Loosen 2 nuts of intake manifold, withdraw intake system assembly.
5. Remove vacuum pipe, fuel pipe, auto choke, cap of spark plug, rear brake cable carburetor pipe, starter motor cable.



6. Remove the rear section of muffler, dismantle the 2 bolts of rear brake caliper, then remove the rear brake system assembly away from rear fork.



7. Loosen bolts of upper & lower engine hanger.

8. Remove the engine.

## B. Installing Engine

1. To install engine, please reverse the Above procedures.
2. Locking torque:
  - M8: 2.0-3.0kgf.m
  - M10: 3.0-4.0kgf.m
  - M12: 5.0-6.0kgf.m
3. After installing, please do the following Checking and adjustment:
  - a. Wiring for each circuit.
  - b. Throttle cable
  - c. Rear brake check.
  - d. fuel and oil route



**(1) Drive pulley, starter clutch. driven pulley**

- A. Troubleshooting
- B. Measurement data
- C. Driving pulley
- D. Starter
- E. Clutch driven pulley

A.Troubleshooting:

a.Engine starts, but vehicle don't move.

- 1.driving belt worn out
- 2.driving plate worn out
- 3.clutch lining worn out
- 4.driving plate's spring broken

b.the vehicle stops or tremble when running.

- 1.clutch lining spring cracked or broken.

c.Can't reach high speed, no pick-up

- 1.driving belt worn out.
- 2.Driving plate spring distortion.
- 3.Weight roller worn out
- 4.Driving plate dirty.

Note:

No grease and oil should be distributed over driving belt and driving plate.

B. Measurement data

Item	Standard value ( mm )	Limit of use ( mm )
The inner dia. Of slide driving plate	24.011~24.052	24.10
The outer dia. Of boss, movable Driving plate	23.960.~23.974	23.940
Belt width	20.0~21.0	19.0
Clutch lining thickness	3	1.5
Clutch outer inner diameter	125.0~125.2	125.5
Driven plate spring, free length	151	127
The outer diameter of driven Plate sets	33.965~34.025	33.95
The inner diameter of slide Driven plate	34.000~34.025	34.06
The outer diameter of weight Roller set	17.920~18.080	17.40

### (C)Driving Pulley

1.Take off the screws of left cover, remove the left cover.

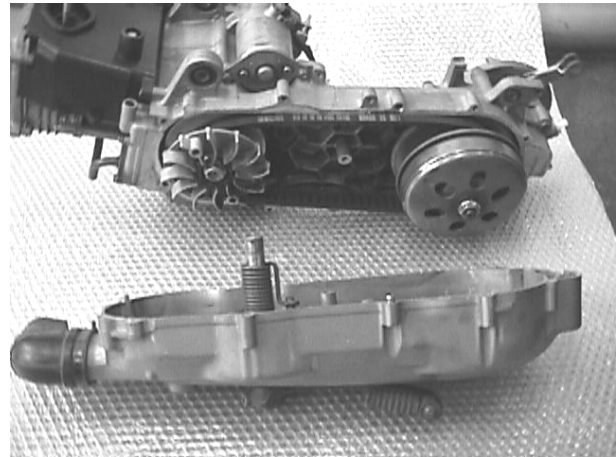

2.Remove the lock nuts of driving Plate and the nuts of Starter gear And clutch.

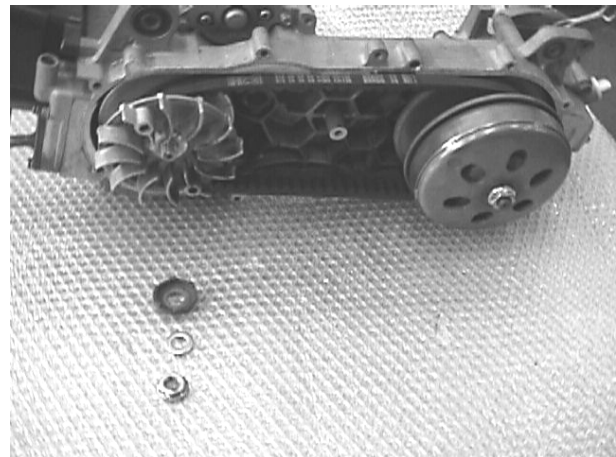

3.Take off the ramp plate, Belt and clutch.

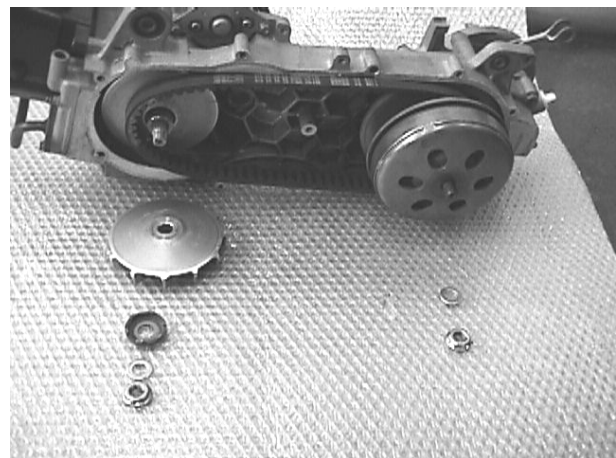

4. Take off the boss and driving plate.

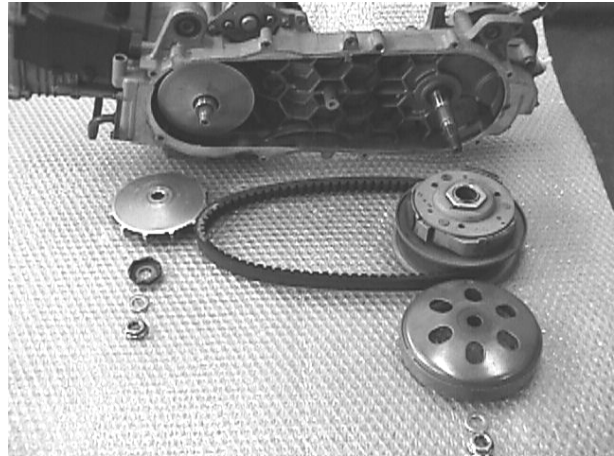

5. Continuous Various Transmission engagement speed inspection

- Connect an electric tachometer.
- Seated on the motorcycle with on level ground, increase the engine's speed slowly and notice the RPM at which the motorcycle begins to move forward.

Specified Engagement RPM :  $3100 \pm 300$  rpm

6. Clutch "LOCK-UP" inspection

- Apply the rear brake as firm as possible
- Briefly open the throttle fully and notice the maximum engine RPM sustained during the test cycle.

Specified Clutch "LOCK-UP" RPM :  $5200 \pm 400$  rpm

5.To assemble the driving pulley, reverse the whole procedure.

Locking torque:

1.Nut of driving pulley M12: 4.0-5.5kg/m.

2.Locking nut of clutch M12: 4.0-5.5kg/m

#### 6.Checking driving belt

(1)check driving belt is cracked or not  
rubber and fiber is loosened or not  
also check if they are extraordinary  
worn out.

(2)driving belt width:

limit of use :change it below 19mm

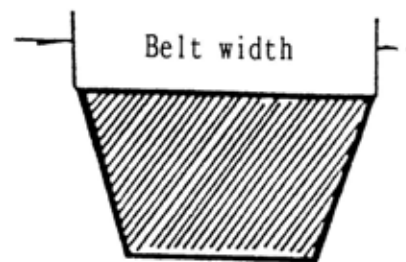

#### 7.Disassemble slide driving plate set.

(1)Remove bush of slide driving plate.

(2)Remove screw, and disassemble the  
cover of slide driving plate.

(3)Remove ramp plate.

(4)Remove weight roller.

#### 8.Checlong

(1)Check the wearing condition of  
weight roller.

Limit of use : change it below 17.4mm

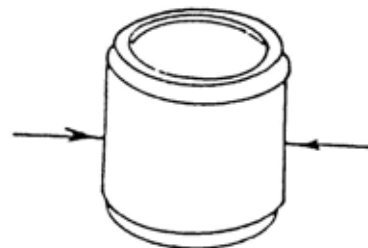

Check the wearing condition

- (2) Check gasket inner dia of slide driving plate: limit of use : change it over 24.1mm.

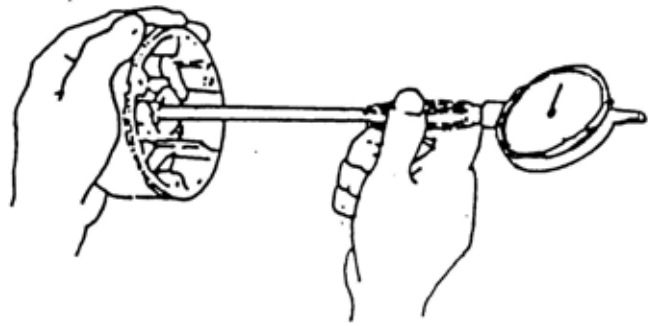

- (3) Check the driving pulley surface wearing condition.

- (4) Check the outer diameter of the contact surface of the movable driving plate.

limit of use : change it below 23.94mm.

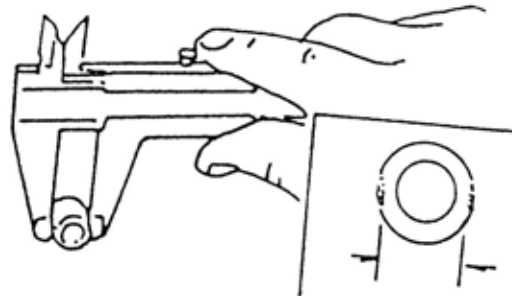

## 9. Assemble the slide driving plate.

- (1) Clean up the inside surface of slide driving plate, then assemble the roller.
- (2) Assemble the ramp plate.

- (3) Other procedure refers to the opposite procedure of disassembling.

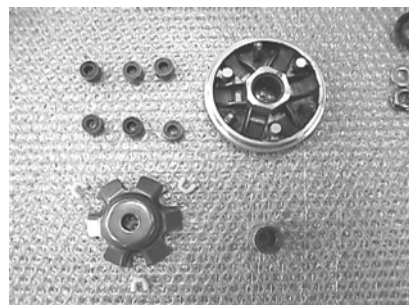



#### D.Starter dismantle

1.Dismantle left crankcase cover

2.Remove hexagon nut, then remove the starter lever.

3.Remove five screw of separated plate.

4.Remove start spring from  
start returning position.

5.Remove driven gear comp. of  
kick starter.

6.Remove the retaining C-type  
Ring.

7.Remove spindle comp.  
of kick starter.

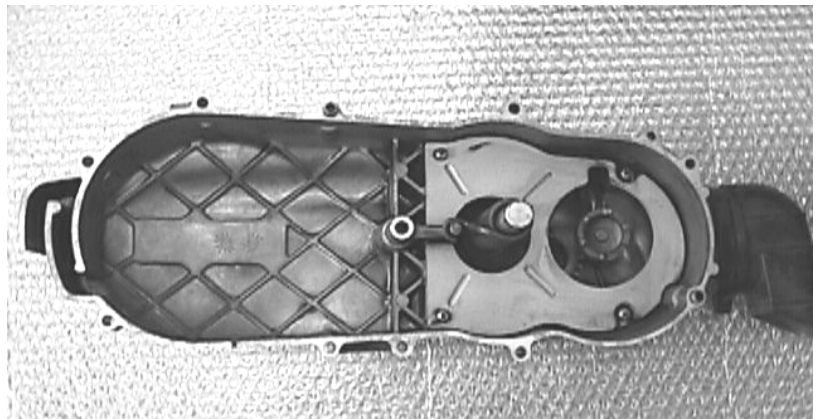

8.Checking starter

- a. Check the wearing condition of the outer diameter of spindle comp and the inner diameter of bush and gear.
- b. Check the wearing condition of shaft of driven gear comp. Gear sets and ratchet.

9.Assembling the starter

Assemble the starter follows the.

Opposite procedure of dismantling.

Locking torque : M6: 1.0~1.2kg/m.

Note:

- ①Make sure one end of the torsion spring is hooked on the groove of driven gear, and another end of torsion spring is hooked on the pole of inside of left crankcase.
- ②Put some grease in every shaft and gear sets before assembly.

## E. Clutch driven pulley

### 1. Dismantling the clutch

- a. Remove left crankcase cover.
- b. Remove driving plate.
- c. Remove driving belt.
- d. Remove locking nut, then remove clutch.

### 2. Assemble the clutch : follows the opposite procedure of dismantling.

Locking torque:

M12: 4.0~5.5kg.m

### 3. Checking clutch:

dismantling tool

#### a. Check clutch driving face.

Check clutch cover about its wearing condition  
And inner diameter measurement.

- limit of use: change it above 125.5mm

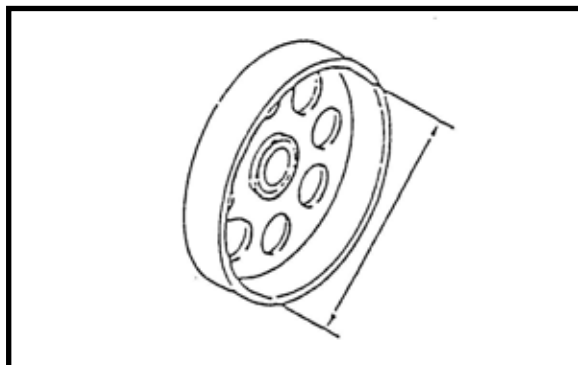

#### b. Check clutch lining wearing condition and

Measure the lining thickness.

- limit of use : change it below 1.5mm.

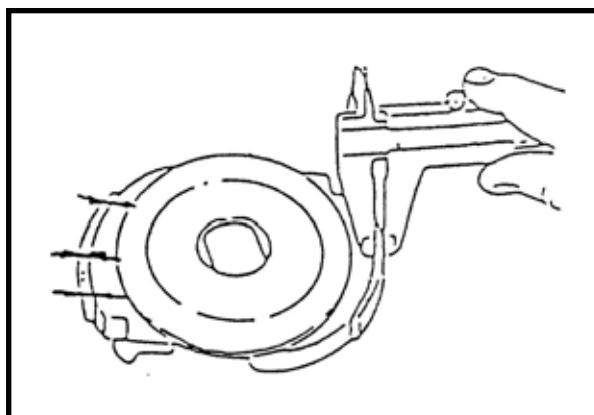

c. Check driving spring free length.

Standard: 151mm

Limit of usage:

Change it below 127 mm

d. Check wearing condition of driving plate sets. And measure outer diameter.

● limit of use: change it above 33.95mm.

e. Check wearing condition of slide driven plate.

And measure its Inner diameter.

● limit of use : change it above 34.00mm.

f. Check is there any wearing occur to the ditch

g. Check wearing condition of oil seal, if necessary, change a new one.

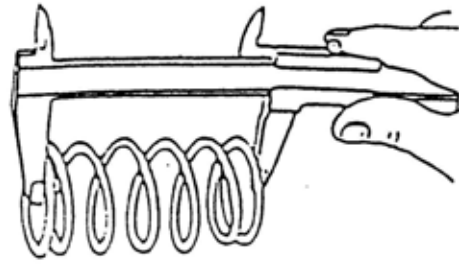

## **(5)Cylinder head and valve**

**A.Trouble shooting**

**B.The operation data information**

**C.Dismantling and installing**

## A. Troubleshooting.

If the cylinder head is malfunctioned, usually it can tell from the measurement of the Compression pressure or from the noise that comes from the upper part of the engine.

### 1. Unsmooth idle speed

-Compression pressure is too low.

### 2. Insufficient compression pressure.

-Poor adjustment of valve clearance

-Valve being burned out or bent

-Valve timing is not correct

-Valve spring is damaged.

-Poor sealing of valve base.

-Leakage in Cylinder head gasket.

-Cylinder head twisted or cracked.

-Spark plug is not properly installed.

### 3. Compression pressure is too high.

-There is too much carbon accumulated in the combustion chamber.

### 4. There is white fume coming out from the exhaust pipe.

-The valve stem or valve guide pipe is worn out.

-Valve stem's oil seal is damaged.

### 5. Abnormal noise

-Poor adjustment of valve clearance

-Valve burned or damaged spring

-Camshaft is worn out.

-Chain adjuster is worn out.

-Camshaft, valve rocker arm is worn out.

## B. The operation data information

Description	IN/EX	Standard Value (mm)	Limit of use (mm)
Clearance between adjuster tapped Screw and valve stem (Before warm up)	IN	0.08	-
	EX	0.08	-
Compression pressure(throttle open full)		12kg/750rpm 11kg/700rpm	(125CC) (150CC)
Height of the cam's convex part	IN	26.3(125CC) 26.625(150CC)	25.9(125CC) 26.23(150CC)
	EX	26.3(125CC) 26.53(150CC)	25.9(125CC) 26.13(150CC)
Inner diameter of rocker arm shaft	IN	10.00~10.015	10.10
	EX	10.00~10.015	10.10
Outer diameter of rocker arm shaft	IN	9.972~9.987	9.91
	EX	9.972~9.987	9.91
Valve base angle	IN&EX	1.0	1.8
Outer diameter of valve stem	IN	4.975~4.900	4.90
	EX	4.955~4.970	4.90
Inner diameter of valve guide	IN	5.000~5.012	5.30
	EX	5.000~5.012	5.30
Clearance between valve stem and Valve guide	IN	0.010~0.037	0.08
	EX	0.030~0.057	0.10

### C.Dismantling and installing the Cam shaft

- 1.Take off the left cover.
- 2.Remove the intake pipe from the Cylinder head cover.
- 3.Take off the 4 bolts of the cylinder head cover and take off the cylinder head cover.

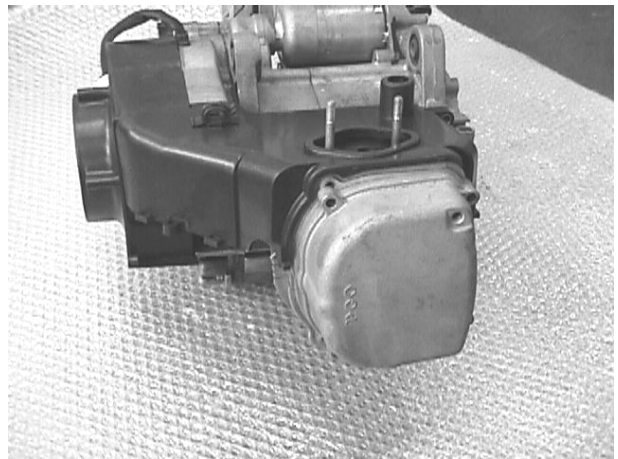

- 4.Turn the flywheel counterclockwise and let the "T" mark on the flywheel point to the crankcase mark and make the round hole on the cam chain gear point upwards.

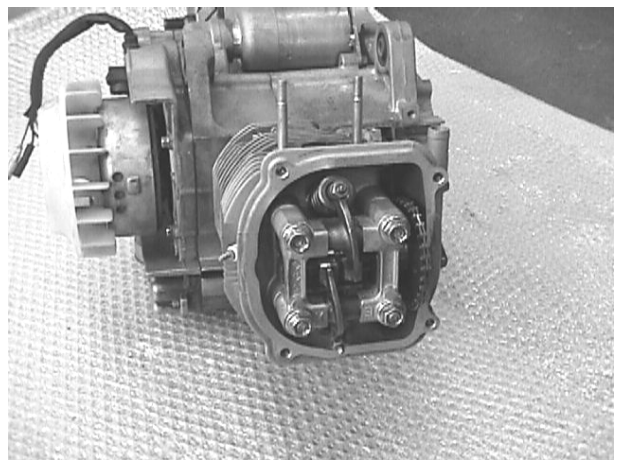

- This is the upper dead point of compression.
- 5.Take off the cam shaft holder, the nut and the locking pin.
  - 6.Remove the cam gear from the cam chain.
  - 7.Remove the cam shaft.

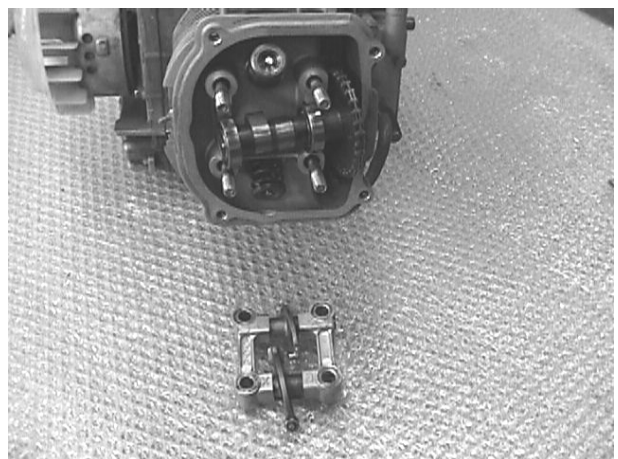

## Check cam shaft

Check the convex surface and the height and see whether it has been damaged.



### Limit of Use:

IN :replace it below 25.90(125CC), 26.23mm(150CC)

EX :replace it below 25.90(125CC), 26.13mm(150CC)

Check camshaft. If the bearing is loosen or worn out, change the whole set if necessary.

## Check cam shaft holder

- 1.Check the cam shaft holder, cam rocker arm, and cam Rocker arm shaft and see whether it is loosen or worn out.

### NOTICE:

Do check if there is any damage on the cam rocker arm Sliding surface.

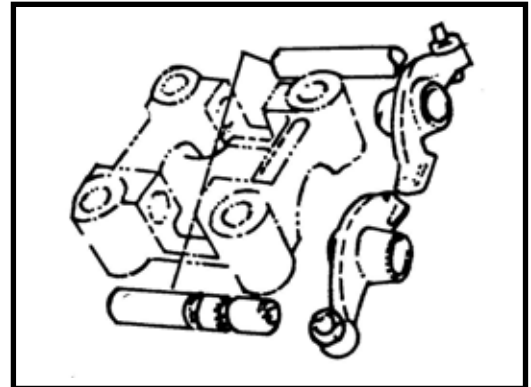

- 2.Cam shaft holder and cam rocker arm outer dia measurement:

Limit of use : replace it above 10.10mm.

- 3.Cam rocker arm inner dia measurement:

Limit of use : replace it above 10.10mm.

- 4.Cam rocker arm shaft and rocker arm outer dia measurement:

Limit of use : replace it below 9.91mm.

- 5.Clearance between the Cam rocker arm and rocker arm shaft.

Limit of use : replace it above 0.10mm.

## WHEN INSTALLING:

- 1.The mark “EX” on the cam shaft holder is the exhaust rocker arm, one-way stopper.

Install the exhaust rocker arm, the inlet rocker arm, and the rocker arm shaft.

### NOTICE:

- a.The tangen angle of the heat side of intake valve’s rocker arm shaft is to match with the bolt of the cam holder.
- b.The tangen angle of the exhaust valve’s rocker arm shaft is to match with the bolt of the cam holder.

- 2.Turn the flywheel to make the T mark pin correctly. The hole on the cam chain gear should point upwards. Both the left and right concave points and the cylinder head are at parallel position (convex part of cam shaft points upwards), then install the cam shaft on the cylinder head.

- 3.Install the cam chain onto the cam shaft gear.

- 4.Install the locking pin.

- 5.Install the camshaft holder, washer and nuts on the cylinder head.

- 6.Lock tightly the cylinder head nuts.

Locking torque: Cam shaft holder nuts:2.0kg-m

### NOTICE:

- a.Put some grease on the bolt thread of cam shaft holder
- b.Lock the nuts of the cam shaft bracket in “cross” sequence for 2-3 times.

- 7.Adjust the valves clearance.

## Dismantling the cylinder head:

- 1.Remove the carburetor.
- 2.Remove the muffler.
- 3.Remove the fan cover.
- 4.Remove the bolts on the engine cover.
- 5.Remove the camshaft.

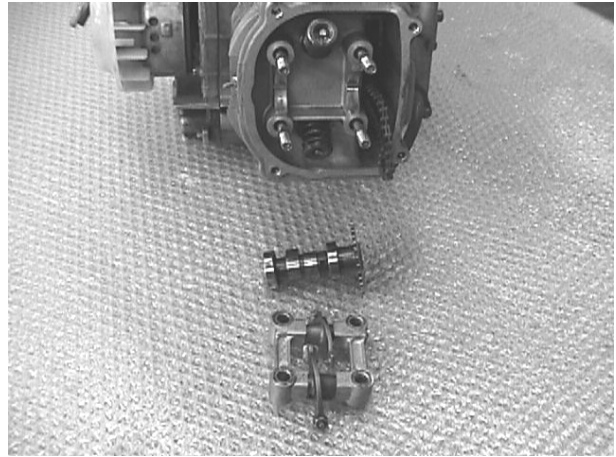

- 6.Remove the cylinder head
- 7.Remove the lock pin, cylinder head gasket.
- 8.Remove cam chain guide

### Notice:

- Not to injure the contact Surface of the cylinder.
- Avoid any object dropping into the engine.

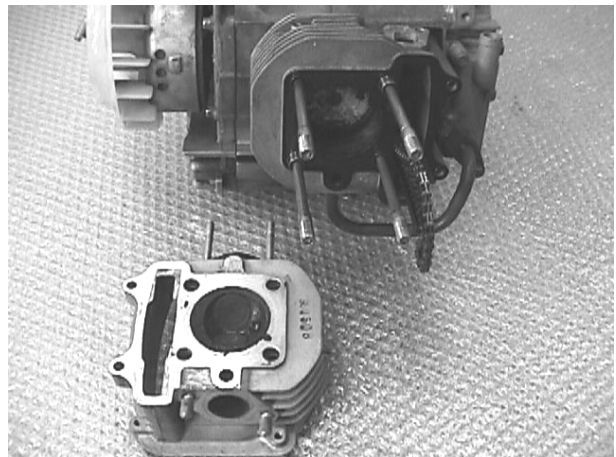

## Further dismantling

- Use the valve contracting tool to remove valve pin, supporter, the valve spring collar, valve spring and valve stem oil seal.

### Notice:

- Valve Spring has to be operated by the valve spring contractor.
- To assemble the cylinder head, please follow the opposite procedure as above.



## (6)Cylinder and piston

- A.Trouble shooting
- B.The Operation notice
- C.Data
- D.Dismaniling cylinder, piston
- E.Installing cylinder, piston

### C.Data (150CC)

Part name /description		Standard value ( mm )	Limit of use ( mm )	
Cylinder	Bore	56.990~57.010	57.100	
	Curve	-	0.005	
	Cylindrility	-	0.005	
	Roundness	-	0.005	
Piston/ Piston ring	Clearance b/w Piston and Piston ring	1st ring	0.03~0.07	0.10
		2 <sup>nd</sup> ring	0.02~0.06	0.10
	Clearance of cutting section	1st ring	0.10~0.25	0.50
		2 <sup>nd</sup> ring	0.10~0.25	0.50
		side ring	0.2~0.7	---
	Piston outer diameter		56.975~56.990	56.90
	Measuring location of piston outer dia.		Down to 5 mm from the piston skirt	---
	Clearance b/w piston and cylinder		0.025~0.035	0.10
Piston pin hole inner dia		15.006~15.012	15.030	
Piston pin outer diameter		14.990~14.992	14.96	
Clearance between piston and piston pin		0.020~0.017	0.025	
Connecting rod small end inner dia		15.010~15.028	15.060	

## A. Troubleshooting.

- a. Compression pressure is too low, difficult to start engine and engine running unsmoothly.
  1. Cylinder head gasket cracked
  2. Spark plug is not well locked
  3. Piston ring worn out or cracked
  4. Cylinder, piston worn out.
  5. Reed valve is out of order.
- b. Compression pressure is too high; Engine overheating; abnormal noise.
  1. piston tip has too much carbon accumulated.
- c. Abnormal piston noise
  1. Cylinder and piston worn out.
  2. Piston pin hole or Piston pin worn out.
  3. Connecting rod small end or bearing worn out.
- d. Abnormal piston or cylinder noise
  1. Piston ring worn out or cracked
  2. Cylinder worn out or cracked

## B. The operation notice

1. Clean before operation to avoid particles dropping into the engine.
2. The contact surface of gasket must be clean.
3. Dismantle cylinder and cylinder head by screw driver. Do not injure the contact surface.
4. Cylinder inner surface and piston outer face can't be injured. Contact Surface should lubricate by specified oil.

## C. Data (125CC)

Part name /description		Standard value ( mm )	Limit of use ( mm )
Cylinder	Bore	51.490~51.510	51.60
	Curve	-	0.005
	Cylindricity	-	0.005
	Roundness	-	0.005
Piston/ Piston ring	Clearance b/w Piston and Piston ring	1st ring	0.03~0.07
		2 <sup>nd</sup> ring	0.02~0.06
	Clearance of cutting section	1st ring	0.15~0.35
		2 <sup>nd</sup> ring	0.15~0.35
		side ring	0.2~0.8
	Piston outer diameter	51.460~51.480	51.40
	Measuring location of piston outer dia.	Down to 7mm from the piston skirt	-
	Clearance b/w piston and cylinder	0.025~0.035	0.10
Piston pin hole inner dia	13.022~13.013	13.045	
Piston pin outer diameter		12.996~13.00	12.96
Clearance between piston and piston pin		0.02~0.017	0.025
Connecting rod small end inner dia		13.015~13.028	13.060

## D.Dismantling

### a.Dismantling Cylinder

- 1.Remove the cylinder head.
- 2.Remove 2 bolts, then the camshaft chain adjuster
- 3.Remove CAM chain guide.
- 4.Remove cylinder.
- 5.Remove the cylinder gasket, lock pin and clean the gasket on the cylinder.

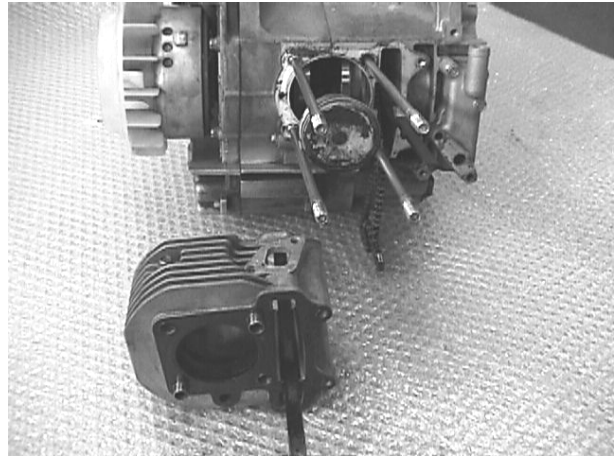

### b.Dismantling piston

- 1.Remove the piston pin clip.

NOTICE:

Dot' drop the clip into the crankcase.

- 2.Remove the piston pin and take off the piston.
- 3.Check piston, piston pin, piston ring.
- 4.Remove the piston ring

NOTICE: NOTICE:

Don't make piston ring worn out or damaged

- 5.Clean the carbon in the groove of the piston ring.

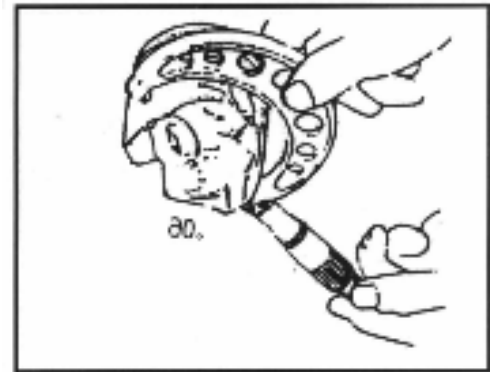

### c.PISTON OUTER DIA MEASUREMENT:

- 1.Measuring location:

Perpendicular to the piston pin hole, down to 7mm(125CC), or 5mm(150CC) from the piston skirt.

Limit of use : change it when less than 51.4mm.( 125CC)

Limit of use : change it when less than 56.9mm.( 150CC)

- 2.The clearance between the piston and piston pin:

Limit of use : change it when above 0.005m

- 3.Checking any wearing, damage inside the cylinder.

Vertical to piston pin, and in X-Y direction to measure cylinder bore from the upper, middle and lower location.

Limit of use : Change it when above 51.6mm.( 125CC)

57.1mm(150CC)

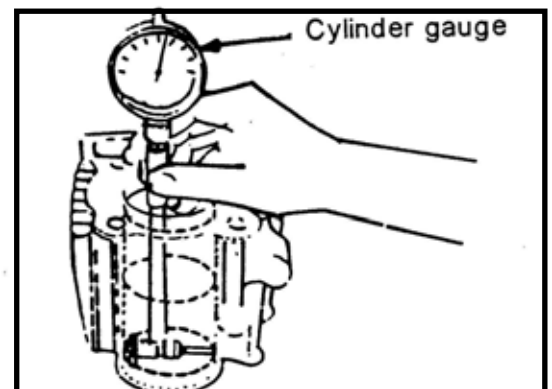

- 4.The maximum clearance between the cylinder and piston pin.

Limit of use : Change it when above 0.1mm.

- 5.The difference between the X and y is the roundness.
- 6.The cylindrility is the max value of the difference between the upper, Middlle and lower position of the inner dia in X or Y direction.

Limit of use : Roundness:change it when above 0.005mm.  
Cylindrility:change it when above 0.005mm.

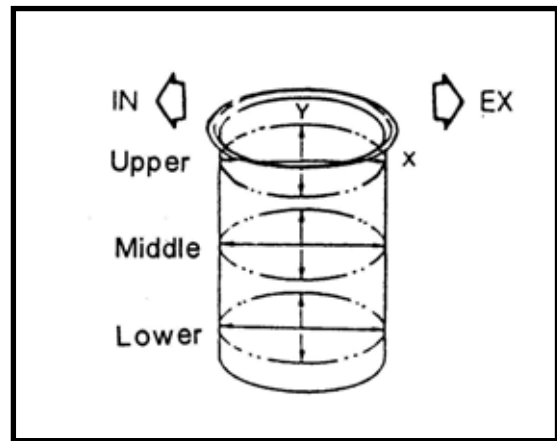

**d.Checking the flatness of cylinder contact surface.**

Limit of use : change it when above 0.05mm.

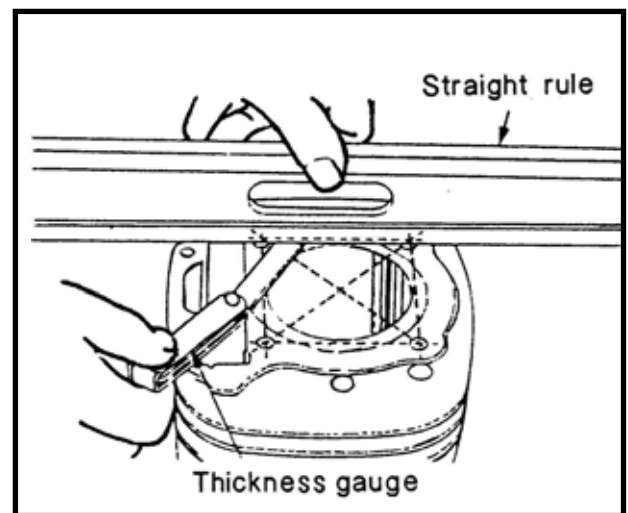

**e.Connecting rod small end inner diameter measurement.**

Limit of use : change a new one when above 13.06mm.( 125CC)  
15.06mm.( 150CC)

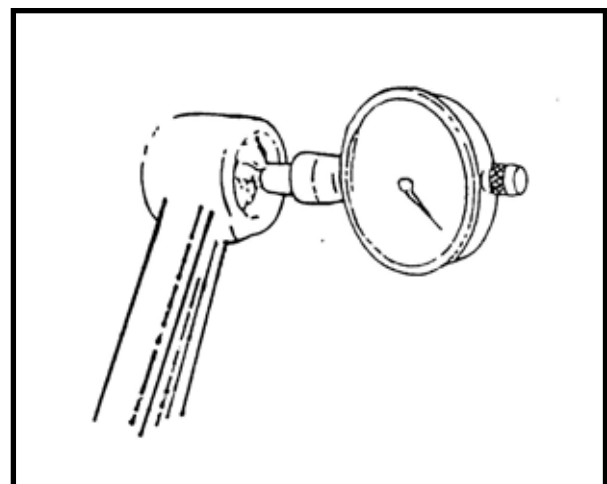

## E. Installing Cylinder and piston

### a. Installing piston and piston rings

1. Lubricate the piston rings by motor oil.

#### NOTICE:

a. Be careful not to scratch the piston and not to break the piston ring.

b. The mark (on the ring) should be upward when installing.

c. After installing, the ring should be smoothly rotated.

### 2. Clean up the residual gasket on the crankcase.

#### NOTICE:

Do not drop other objects into the crankcase.

### 3. Assemble the piston, piston pin and piston pin clip.

#### NOTICE:

a. The mark "IN" on the piston tip should face to the INLET side.

b. Do not drop the piston pin clip into the crankcase and to clog the crankcase with rags.

### b. Installing piston

1. Fix the lock pin and gasket on the crankcase.

2. Lubricate the Cylinder inner surface, piston and piston rings by Motor Oil.

3. Install the piston ring into the cylinder carefully.

#### NOTICE:

a. The piston ring cannot be damaged or cracked.

b. The cutting section of three rings must be arranged at intervals of 120°

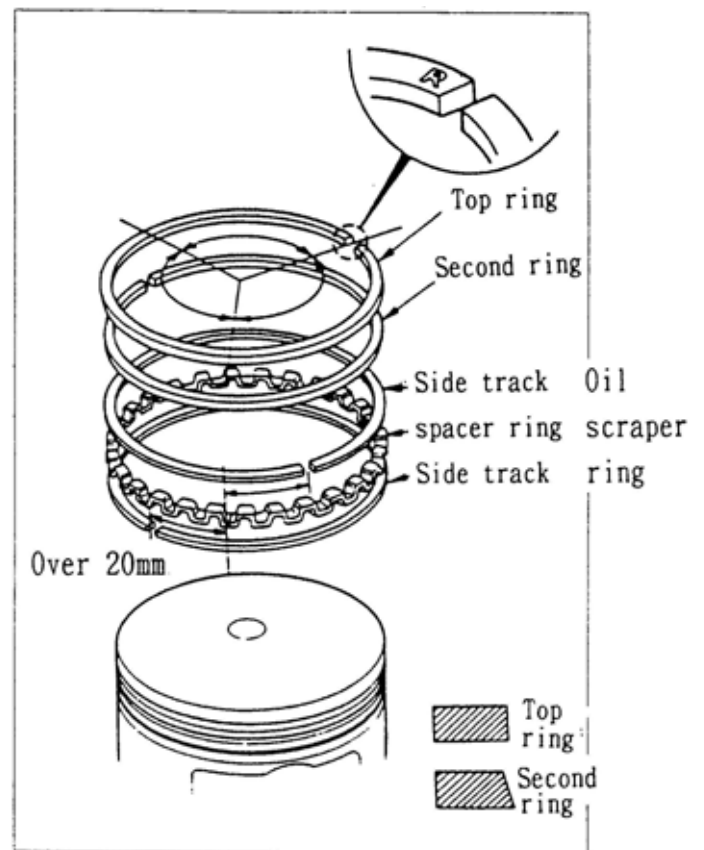

## **(7)A.C. Generator**

A.Dismantling AC generator

B.Installing AC generator

## Dismantling AC generator

1. Dismantle the rear section of muffler.
2. Remove fan cowl.
3. Remove the M6 screws
4. Remove screws of flywheel magneto.
5. Remove the AC flywheel magneto by special tool.

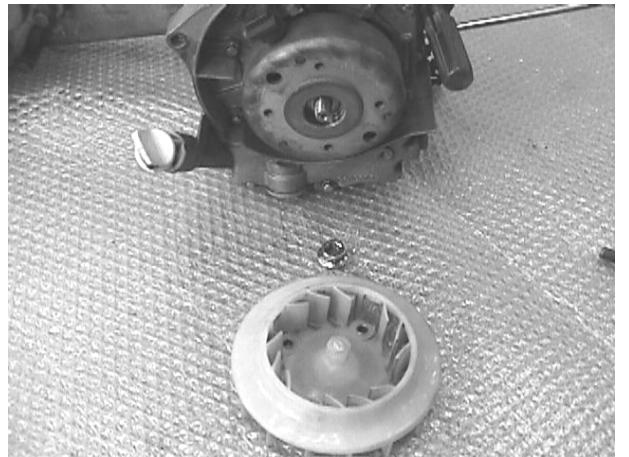
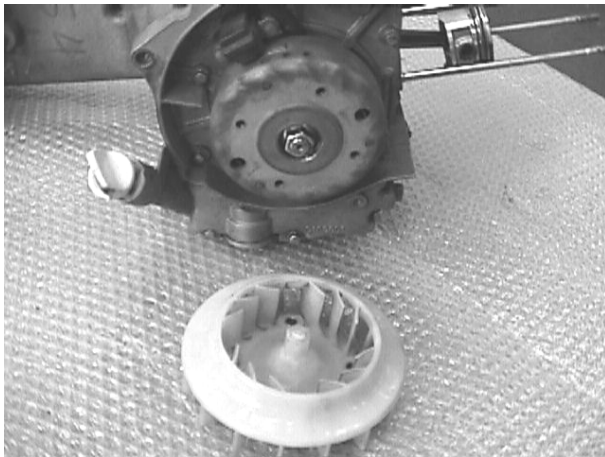

6. Remove the flywheel.
7. Remove the electric plug of AC flywheel magneto.

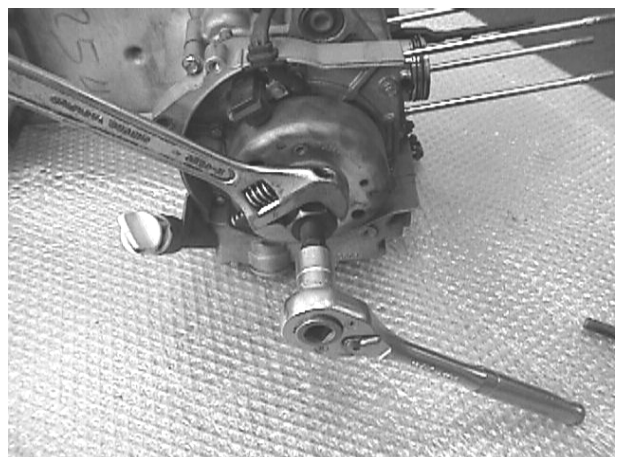

## B. Installing AC generator

To install, please reverse the dismantling procedure.

Locking torque:

M6: 1.0~1.2kg/m

M12: 3.2~4.0kg/m

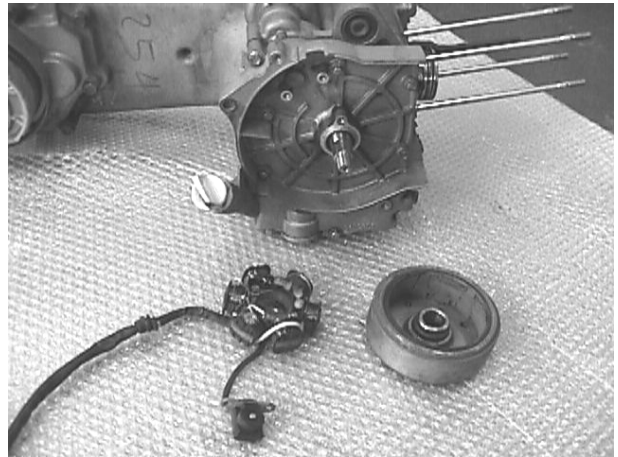



## **(8)Final transmission mechanism**

- A. Troubleshooting.
- B. Dismantle the final transmission mechanism.
- C. Check the final transmission mechanism.
- D. Assemble the final transmission mechanism.

### **A. Troubleshooting**

- Engine can be started, but the vehicle doesn't move.
  - 1.Gear worn-out or cracked.
  - 2.Gear burnt out.
- Noise occur when running.
  - 1.Gear worn out, burnt or gear surface.
  - 2.Bearing worn out of loosen.
- Oil leakage
  - 1.Too much oil
  - 2.Seal worn out or damaged.

## B. Disassemble the final transmission mechanism:

1.Remove the rear wheel.

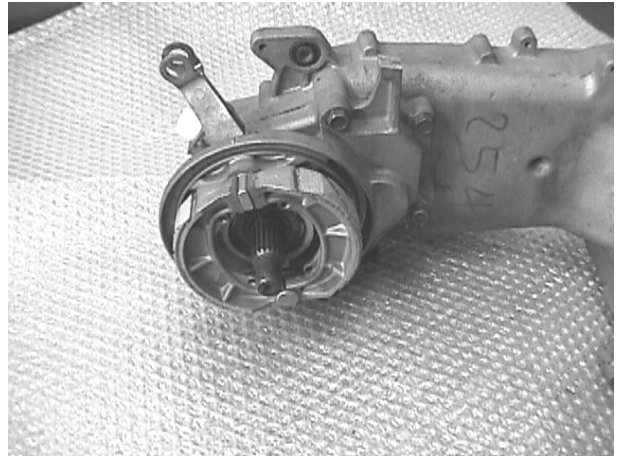

2.Drain the oil in the gear box.



3.Remove the bolt in the gear box cover.

Take off the gear box.

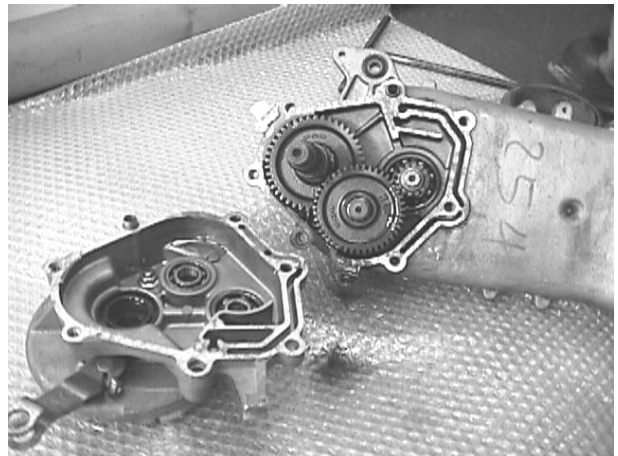

3.Remove the final reduction gear  
And idle gear.

5.Clean up the gear box.

### **C. Check the final transmission mechanism**

1.Check the wearing condition of driving shaft and gears.

Gear teeth number: 14 T (125CC) ; 15 T (150CC)

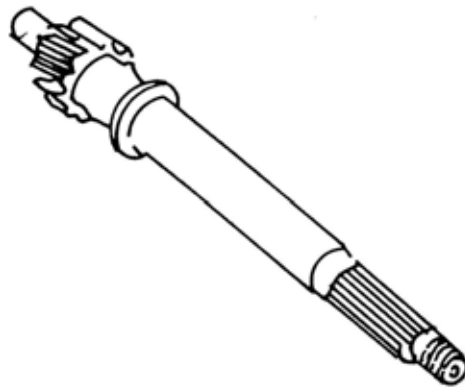

2. Check the wearing condition of idle gear shaft and idle gears.

Gear teeth number      43 T (125CC) ;  
                                         42 T (150CC)

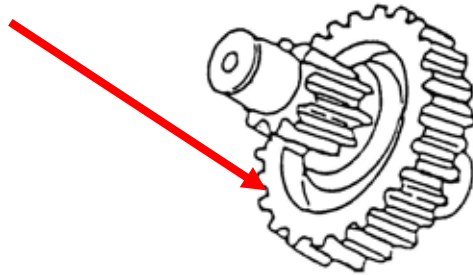

3. Check the wearing condition of the final reduction gear.

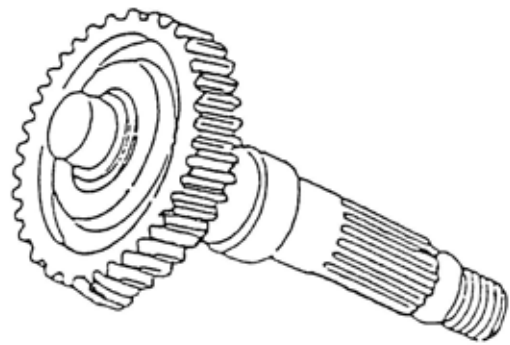

4. Check the wearing condition of the oil seal and bearing.

D. Assemble the final transmission mechanism, please follow the opposite procedure of disassembling. After locking the drain bolt, refill 90cc of gear oil SAE90.

Locking torque:	M6: 1.0~1.2kg/M
	M10: 3.5~4.0kg/M
Drain bolt:	M8: 1.8kg/M

**(9)Crankcase, Crankshaft:**

- A. Disassembling diagram.
- B. Troubleshooting.
- C. Data
- D. Remove crankcase and crankshaft.
- E. Check crankshaft.
- F. Assemble the crankcase.

## A. Disassembling diagram

Torque: 1.0~1.2kg-m

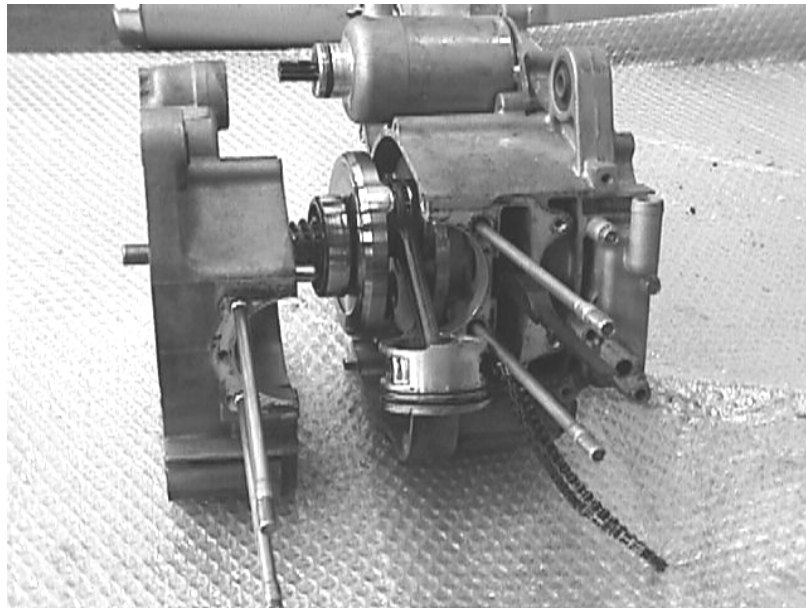

## B. Troubleshooting

Engine noise:

- 1.The bearing of final transmission mechanism is loosen.
- 2.Crank pin of bearing is slack.
- 3.The bearing of gear box is loosen.

### C.Data

Item	Standard value(mm)	Limit of use.(mm)
Clearance of connecting rod big end axle direction	0.10~0.35	0.55
Clearance of connecting rod big end vertical direction.	-	0.04
Swingness of the crank shaft journal.	0.03	0.10

### D. Remove the crankcase and crankshaft by the following procedures:

- 1.Remove the engine.
- 2.Remove the muffler.
- 3.The carburetor.
- 4.Engine corer.
- 5.Cylinder head.
- 6.Cylinder.
- 7.The driving plate.
- 8.AC flywheel magneto.
- 9.The starter clutch.
- 10.Oil pump.
- 11.Bolts of left/right crankcase.

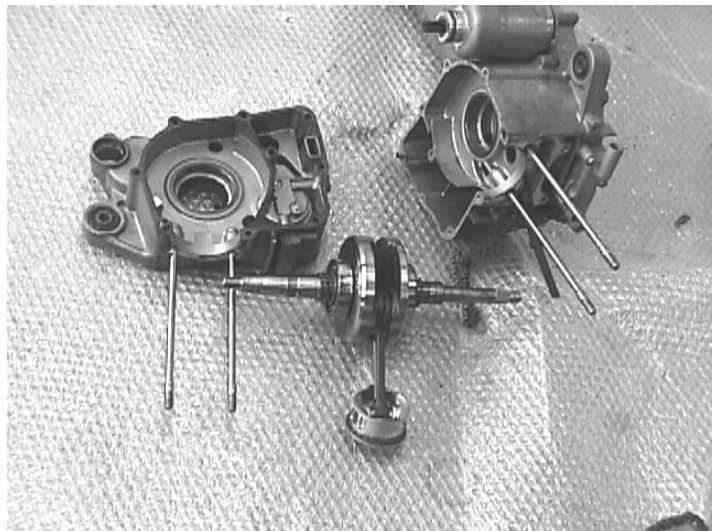

## E. Check crankshaft

1. Measure the difference of the connecting rod big end between the X and Y

Limit of use : replace it when above 0.04mm.

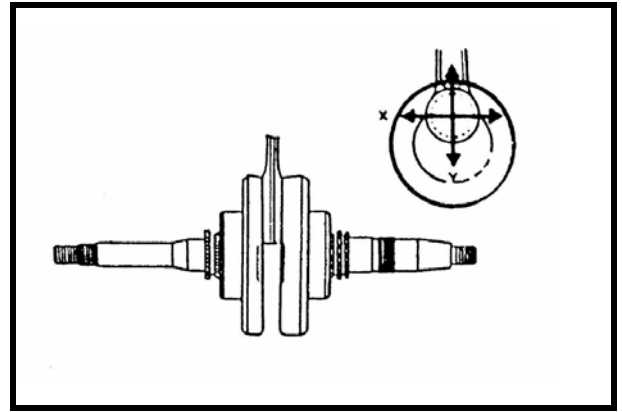

2. Measure the swing ness of the crankshaft journal.

Limit of use	
A	B
Change it when above 0.1mm	Change it when above 0.1mm

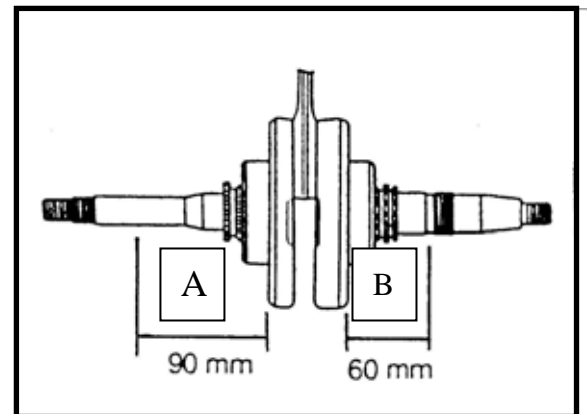

3. Check the looseness of crankshaft bearing.  
If it is loosen, replace to a new one.

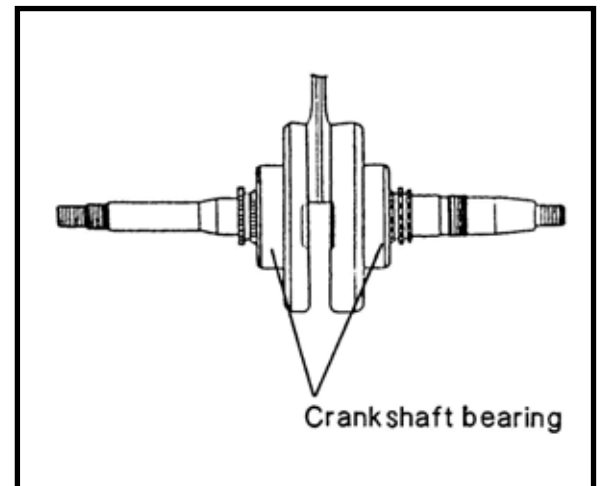

## F. Assemble crankcase:

1. assemble crankcase according to the opposite procedure of disassembling.
2. The locking torque of bolts and nuts are described in previous chapter please refer.



**(10)Carburetor:**

- A.Troubleshooting.
- B.Dismantling the carburetor.
- C.Dismantling the float and nozzle.

**CARBURETOR SPECIFICATIONS:**

<b>ITEM</b>	<b>SPECIFICATION</b>	<b>SPECIFICATION</b>
<b>Model</b>	<b>M2-125</b>	<b>M2-150</b>
<b>Carburetor type</b>	<b>KEIHIN CVK24</b>	<b>KEIHIN CVK24</b>
<b>Bore size</b>	<b>24mm</b>	<b>24 mm</b>
<b>I.D. NO</b>	<b>013</b>	<b>046</b>
<b>Idle r/min</b>	<b>1700 ± 100</b>	<b>1700 ± 100</b>
<b>Float height</b>	<b>18.0 ± 0.5 mm</b>	<b>18.0 ± 0.5 mm</b>
<b>Main jet</b>	<b>#102</b>	<b>#102</b>
<b>Jet needle</b>	<b>4HGGN</b>	<b>4HLGL</b>
<b>Needle jet</b>	<b>P-O</b>	<b>P-O</b>
<b>Pilot jet</b>	<b>#35</b>	<b>#35</b>
<b>Pilot screw (PRE-OPENING)</b>	<b>2 1/4 turns out</b>	<b>1 1/ 2 turns out</b>

## **(A) Troubleshooting**

### **●Difficult to start**

- 1.No sparking in spark plug.
- 2.Compression pressure too low.
- 3.No fuel in the carburetor
  - air cleaner blocked
  - oil pipe blocked
  - bad adjustment of the fuel levelfloat valve is jell

### **●Mixed air too dilute**

- 1.Main jet blocked
- 2.Float valve blocked
- 3.Fuel level too low
- 4.Fuel system blocked
- 5.Second air sucked into intake system
- 6.Bad vacuums during piston movement
- 7.Throttle valve malfunction

● Too much fuel in the engine

1. Air cleaner blocked
2. Mixed air is too dilute in the idle system

● Sparking unsteady while increasing speed

1. Ignition system malfunction.
2. Air mixture is too dilute

● Difficult to start, Ignition off, Unstable idling

1. Fuel system blocked
2. Ignition system malfunction
3. Air mixture is too dilute or too thick
4. Fuel deterioration
5. Second air sucked into intake system.
6. Bad idle adjustment
7. Bad fuel volume adjustment
8. Idle system or fueling system blocked
9. Bad adjustment of fuel level

● Mixture air too thick

1. Auto choke system malfunction
2. Float valve malfunction
3. Fuel level is too high
4. Air route blocked
5. Dirty air cleaner
6. Fuel overwhelming in carburetor

## **(B)Dismantling the carburetor**

- 1.Remove the auto starter connector.
- 2.Remove the throttle cable, then the fuel pipe from the carburetor.

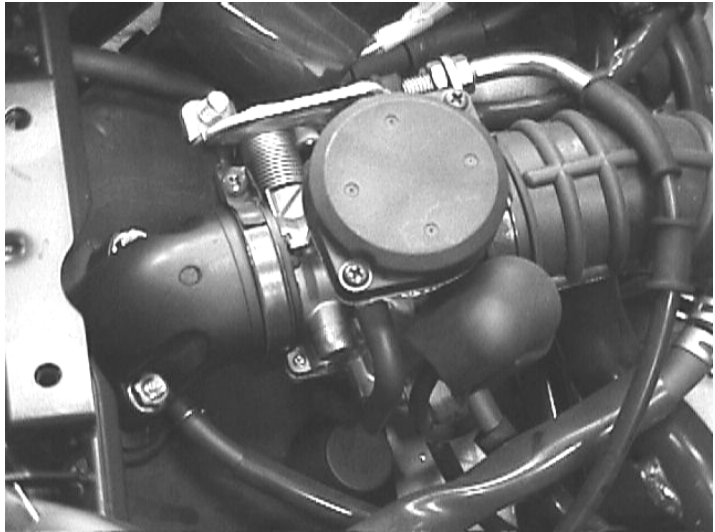

- 3.Remove the screws on the intake manifold.
- 4.Unscrew the fixing belt on the connecting pipe.
- 5.Remove the carburetor.

## Assembling the carburetor

To assemble the carburetor, please follow the reversed procedures of the dismantling and do the following adjustment after installation is finished:

- Adjust the throttle cable
- Idle adjustment

## Adjustment of fuel volume adjusting screws

Note :Fuel volume adjusting screws have been set up properly before sale thus there is no need for self-adjustment. However, when dismantling, a record of the turning loop has to be kept for future assembling purpose. Put up the center stand while adjustment.

- 1.After the engine is warm up, adjust the stopping screw throttle of throttle valve to the standard rpm.  
Idle rpm  $1,700 \pm 100$ rpm
- 2.Adjust the fuel volume adjusting screws to the highest stable rotation.  
This rotation value is the optimum setting of throttle
- 3.Fuel up for several times, make sure that the idle rpm is within the standard rpm.  
Repeat the above procedure if the idle rpm is unstable.

## (C)The float nozzle

### 1.Dismantling

- Remove the screws to take off the float chamber.
- Remove the float, the float pin, and float valve.

### 2.Checking

- Check the float valve, valve base to see whether it is blocked or damaged.
- Check the float valve, valve base surface if sectional worn out or dirty.

Note:  
When the valve is too dirty or severely worn-not, the Valve base will not close completely thus will result In increasing of fuel level and fuel leakage problem. A new replacement is needed.

- Remove the main jet, needle jet base, needle jet, slow jet and fuel adjusting screws.

Note:  
●Avoid any damage on the jets and the fuel adjusting screws.  
●Before dismantling, record the number of turning loops.  
●No screwing-in movement by force to avoid any damages.

- Use the detergent solution to clean the jets. Fuel adjusting

After cleaning off the blockage and the dirt, screw

blow dry by compressed air.

Note:  
Remove the vacuum and air-interrupt valve for Cleaning.

### 3.Assembling

- Assemble the slow jet, needle jet, main jet and fuel adjusting screws.

●Notice  
Record the number of turning loops before dismantling

- Assemble the float valve, float and float pin.

### 4.Checking fuel level

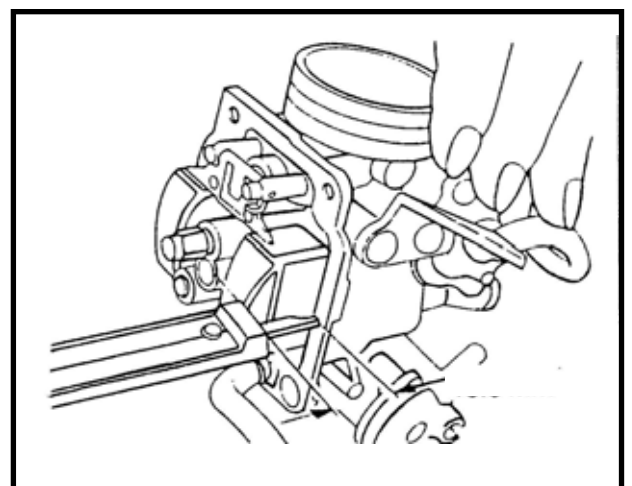
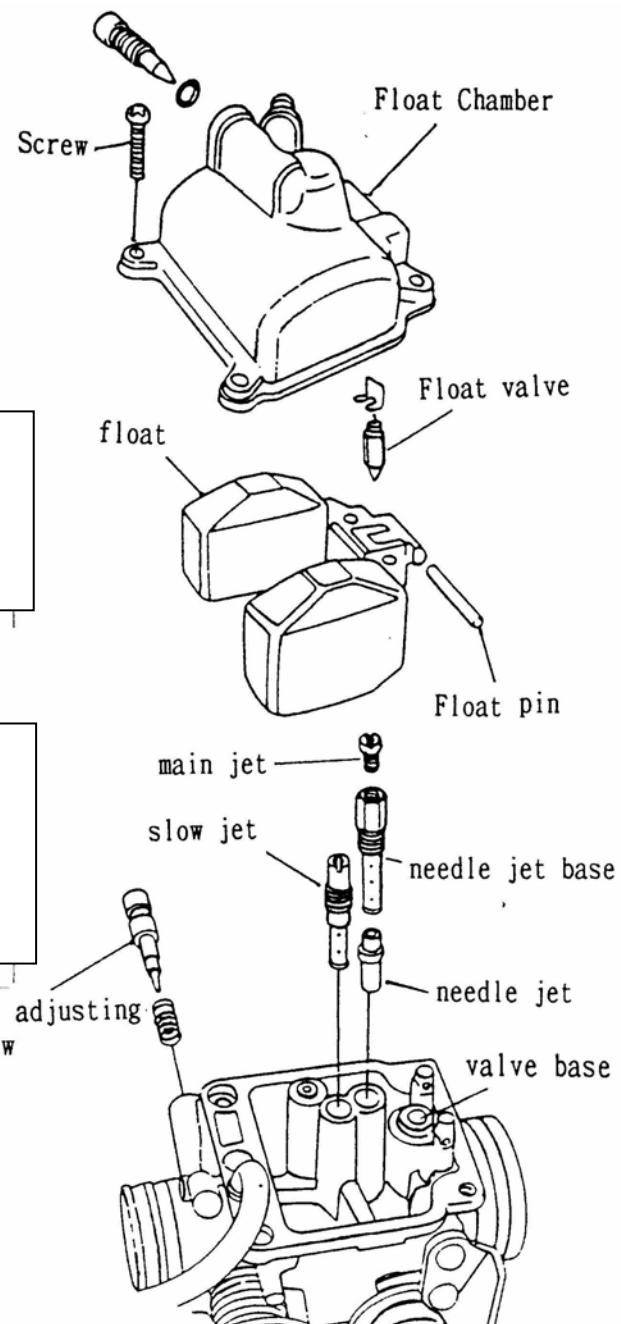

## (12) Fuel tank

### A. Troubleshooting.

#### 1. Engine can't start:

- a. No fuel in fuel tank.
- b. Fuel pipe is blocked.
- c. Auto cock and filter is blocked.
- d. The membrane of auto cock is over swell.

#### 2. The membrane of auto cock is over-extended.

- a. Fuel tank cover's ventilation hole is blocked.
- b. Fuel pipe is crooked, squeezed, or blocked.
- c. Auto cock and fuel filter is dirty.

### B. Fuel supply system diagram:

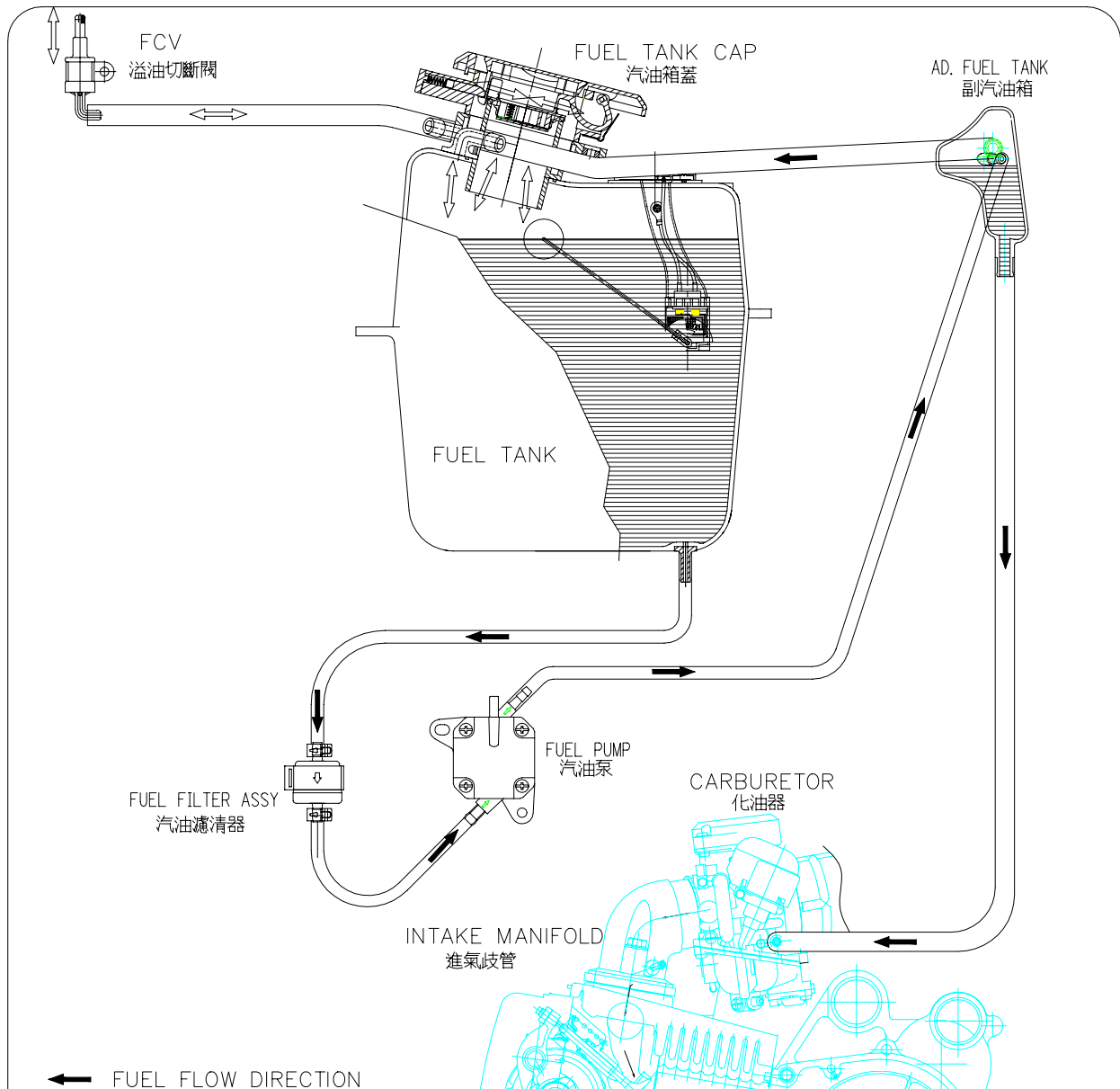

## **B. Dismantling and assembling Fuel Tank**

- 1.Remove the front luggage box.  
Open the fuel tank cover cap.
- 2.Remove the fuel tank cover..



- 3.Remove the fuel pipe.
  - 4.Remove the connecting terminal of the fuel gauge.
- 
- 5.Remove the fuel gauge.
  - 6.Remove the fixing blot of the fuel tank.
  - 7.Take off the fuel tank.
  - 8.When re-assembling, please follow the opposite procedure of disassembling.  
Locking torque: M6: 1.0-1.2kgf-m



D. Oil tank disassembling diagram: (only available for M2-50)

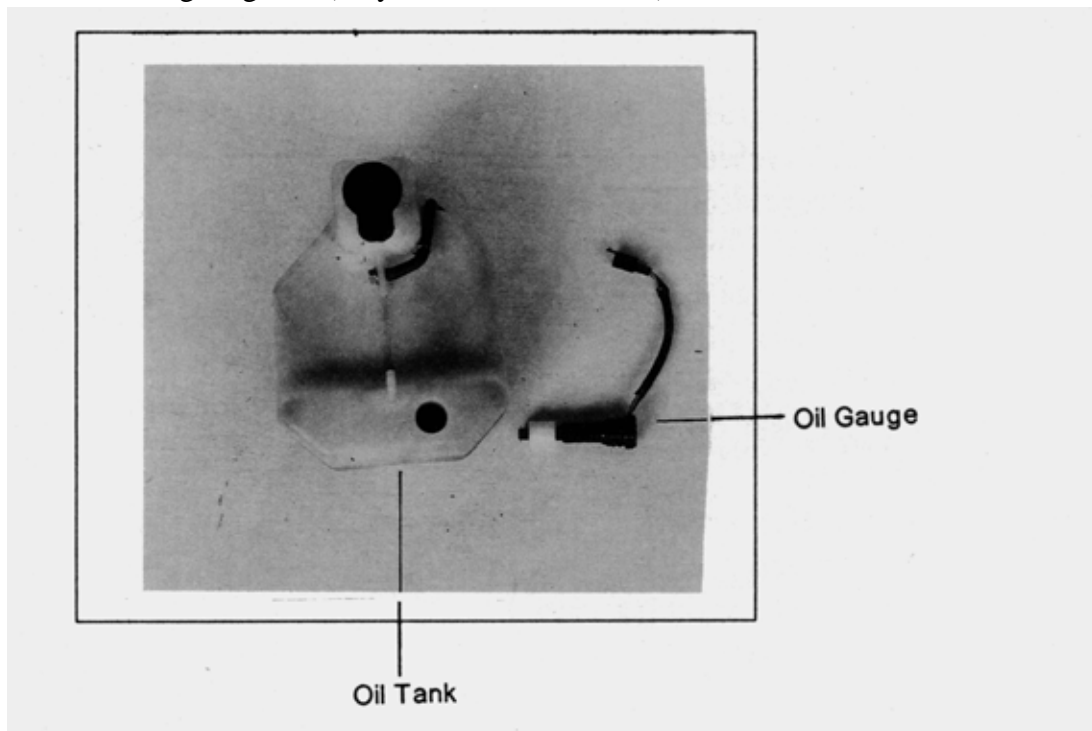

E. Dismantling and assembling oil tank: (only available for M2-50)

1. Drain off the oil.
2. Disconnect plug of oil gauge.
3. Remove the oil tank.
4. Clean the oil tank.
5. To assemble the oil tank, please follow the opposite procedures of dismantling.





## **V. Electric equipment:**

(1) Troubleshooting

(2) Battery

1. Check the cells of battery
2. recharging
3. Test the recharging performance

(3) Recharge system

1. the wiring diagram of recharge system
2. check A.C. flywheel magneto.
3. Check regulator/rectifier.

(4) Ignition system

1. the wiring of ignition
2. check spark plug
3. check H.T. cable and H.V. coil
4. check C.D.I. set

(5) Starting system

1. the wiring of starting
2. checking the starter
3. dismantling the starting motor
4. checking the starting motor

(1) Troubleshooting:

A. Recharge system:

• No power:

1. Battery over discharging
  - ① No electrolyte in battery.
  - ② Battery is bleached
  - ③ Short circuit in the Battery.
  - ④ Regulator malfunction
2. The battery wires are disconnected.
3. Fuse is broken.
4. Ignition switch is abnormal.

• Voltage is too low:

1. Battery recharges insufficiently.
2. The bad connection on wiring system.
3. Recharge system is abnormal.
4. Regulator malfunction.

B. Ignition system:

• The sparking of spark plug is abnormal:

1. Spark plug is dead.
2. Wire connection is broken or short Circuit.
  - ① between A.C. generator and CDI sets
  - ② between CDI sets and High Voltage coil.
  - ③ between CDI sets and main switch.
  - ④ between main switch and spark plug.
3. Main switch is out of order.
4. H.V. coil is not in good function.
5. CDI sets is out of order.
6. A.C. generator is not in good function.

C. Starting system:

• Starting motor can't rotate:

1. The fuse is broken.
2. Battery recharges insufficiently.
3. Main switch is out of order.
4. Starting motor switch is out of order.
5. Front/rear brake switch is out of order.
6. Starter relay is out of order.
7. Wire disconnects or broken.
8. Starting motor is out of order.

• Currency is unstable.

1. The wiring of battery connection is not good.
2. Ignition system connection is not good.
3. Ignition system is short circuit.
4. Lamp system connection is not good or short circuit.

• Abnormal recharge system:

1. The plug connection is not good. wire broken or short circuit.
2. Rectifier is out of order.
3. A.C. flywheel magneto is abnormal.

D. Engine running unsmoothly:

1. Ignition primary circuit.

- ① the wire or plug of wiring connection is not good.
- ② main switch disconnects.

2. Ignition secondary circuit.

- ① Ignition coil is not in good function
- ② Spark plug is dead.
- ③ H.V. coil is not in good function.
- ④ The spark plug cap is not in good function.

3. Ignition timing

- ① A.C. generator is out of order.
- ② A.C. coil is not in good function.
- ③ C.D.I. sets is out of order.

• Starting motor runs weakly.

1. Battery recharges insufficiently.
2. Wiring system disconnects.
3. The alien objects drop in the motor or gear.

• Starting motor can rotate, but engine can't start up.

1. Starting gear is abnormal.
2. Starting motor is reversedly rotating.
3. Battery is out of order.

## (2)Battery:

1.Check the cells of battery.

Always remove the battery negative

Cable(-)first, then positive cable

(+). But connect the positive cable

(+)first, then connect the

Negative cable(-) when assembling.

**M2-50**



**M2-125/150**



## 2.Recharge

- Connection procedure:

connect the positive cable(+) of the negative cable(+) of the battery, and the negative cable(-) of the recharge to the negative cable(-) of the battery.

- Recharging currency:

Please recharge (12V) according to the following current and time.

Standard: 0.4A \* 4-10Hr or Rapid:3A \* 60min(50cc)

Standard: 0.7A \* 5-10Hr or Rapid:3A \* 60min(125/150cc)

**NOTICE:**

This battery is totally sealed. Do not remove seal bolt when recharging.

**Notice:**

- Keep away from fire when recharging.

- The “ON” or “OFF” of recharging. currency must be operated by the switch of recharge. It will cause spark or explosive if plug or unplug the cable directly.

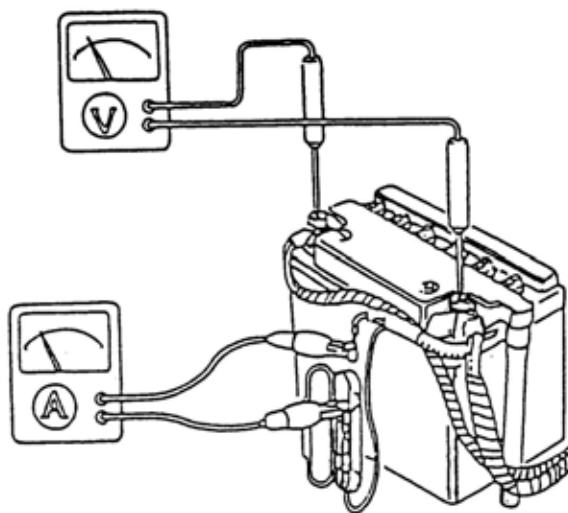

### 3. Testing the recharging performance

- This test needs to be done when the battery is fully recharged.
- This test needs to be done after engine is warm-up.

- a. Disconnect the orange cable of regulator.
- b. Open the fuse box, to remove the white cable.
- c. Connect currency meter between red/white cable and fuse.

While testing, the red wire cable must not touch the frame.

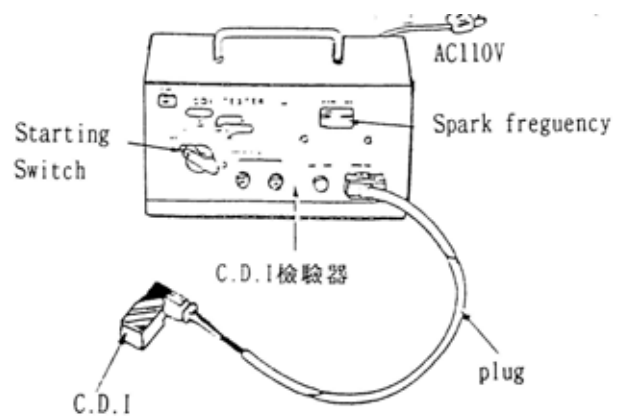

- d. Set the head lamp switch at “OFF”, engine revolution is at 2000 rpm while testing. Then increase the rpm slowly. (Assume the battery is fully charged. situation)

Head Lamp Switch	Recharging rpm	2,500rpm	6,000rpm
OFF(DAY)	Under 2,000rpm	0.6A(MIN)	1.5A(MIN)
ON(NIGHT)	Under 2,000rpm	0.6A(MIN)	1.5A(MIN)

- e. If the testing result does not match the standard value, check the regulator.

(3)Recharge system:

A. Recharge system diagram for M2-50

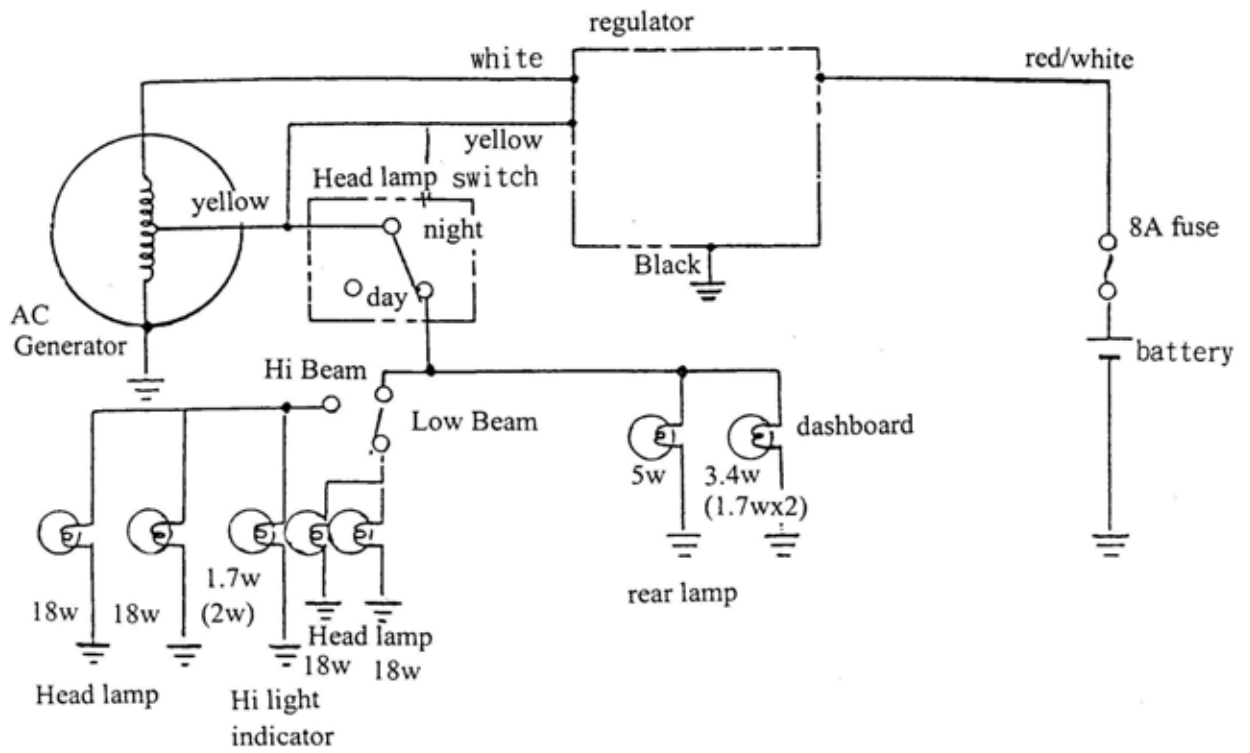

B. Recharge system diagram for M2-125/150

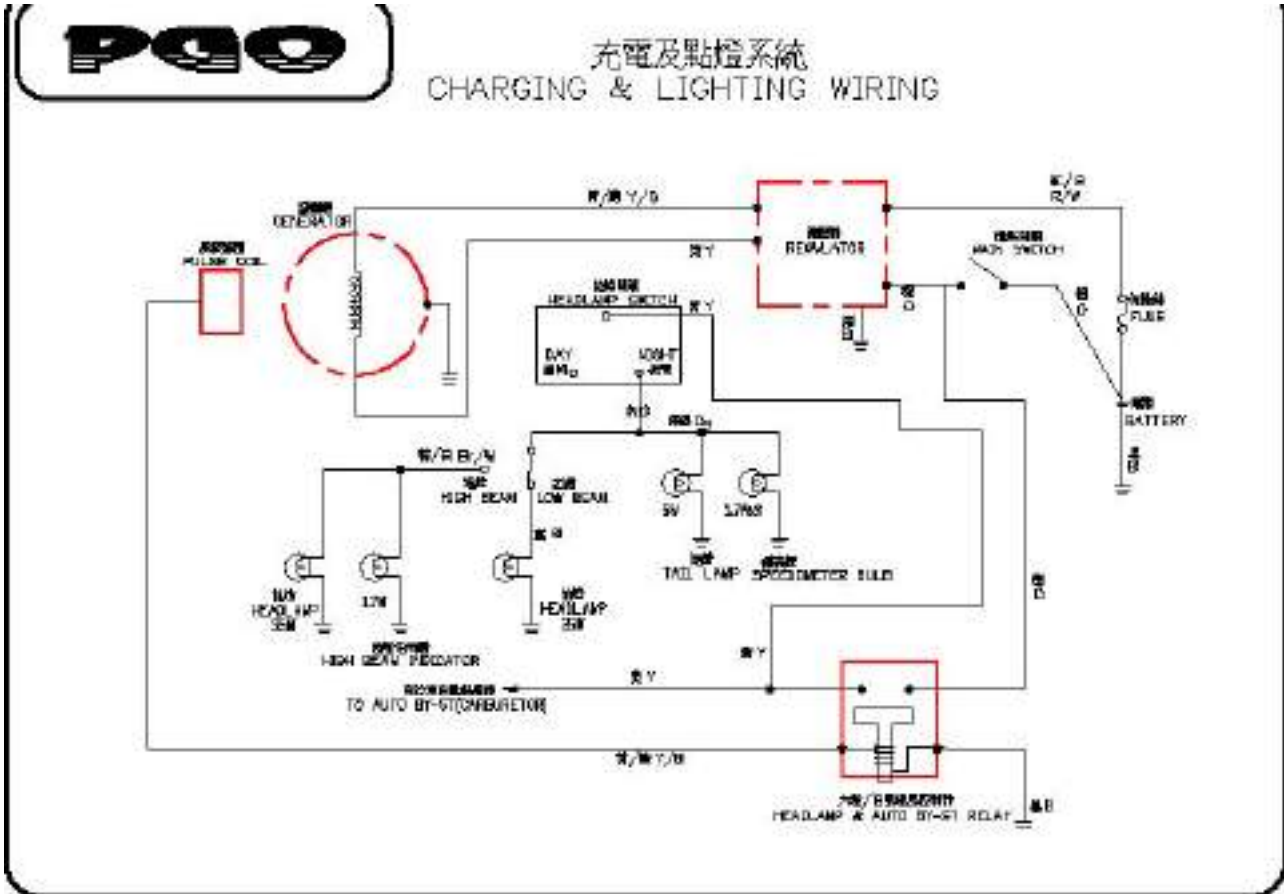

## 2. Check A.C. Generator

- a. Open the seat cover and remove the luggage box.
- b. Measure the resistance value of terminals.

Yellow V.S. black 0.1-1.0
White V.S. black 0.2-2.0



ACG inside

## 3. Check regulator

Measure the resistance value between each terminal,  
It should be in the specified range, otherwise change a new one.

**M2-50**



**M2-125/150**





(4) Ignition system:

1. the wiring or ignition

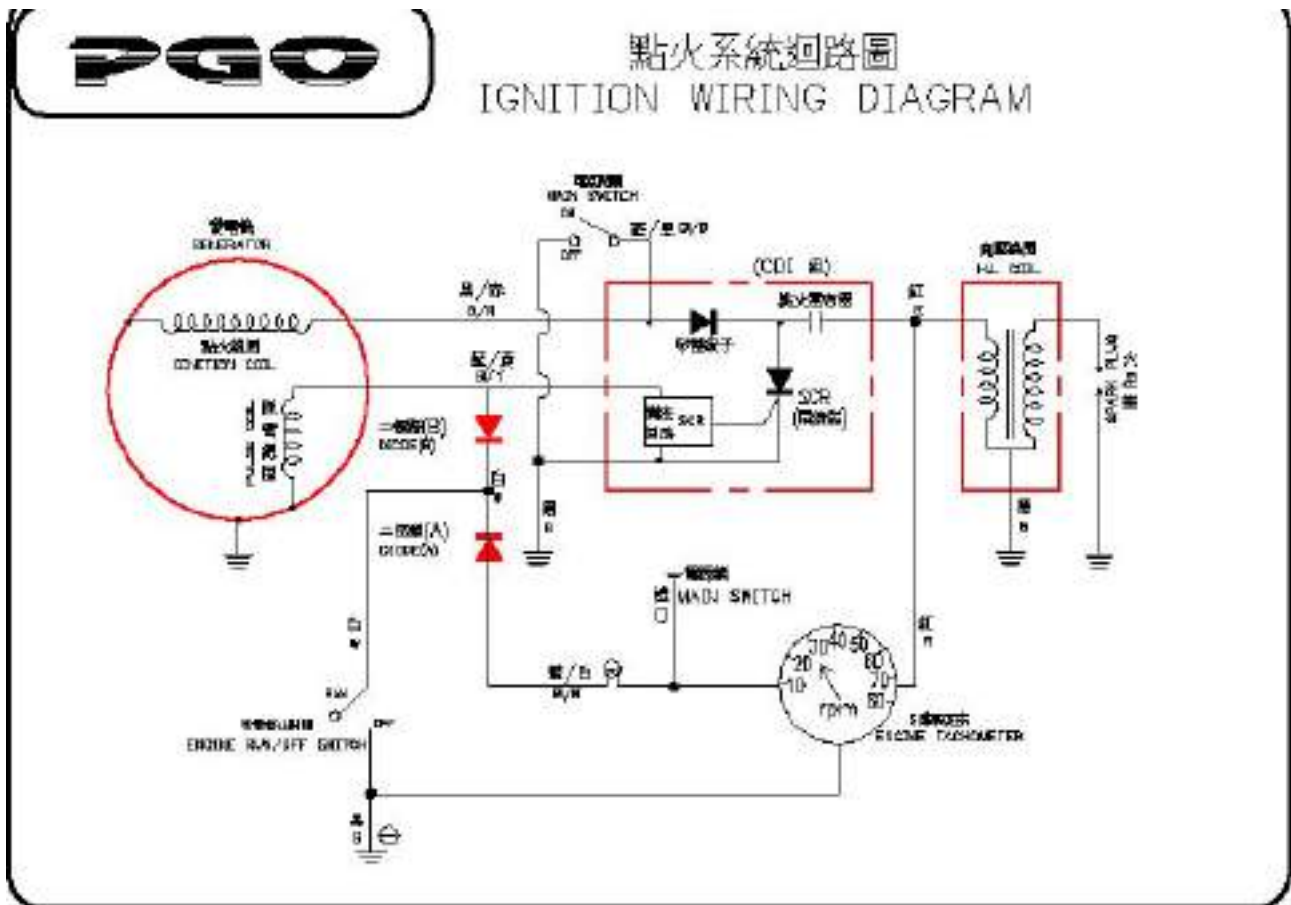

2. Check spark plug.

3. Check the H.V. cable and H.V. coil by using the CDI tester.

4. CDI sets checking.

Check with the CDI tester and please follow the instruction manual.

If the CDI test failed, please change a new one.

Ignition coil



CDI



(5)The starting system:

1.The wiring of starting

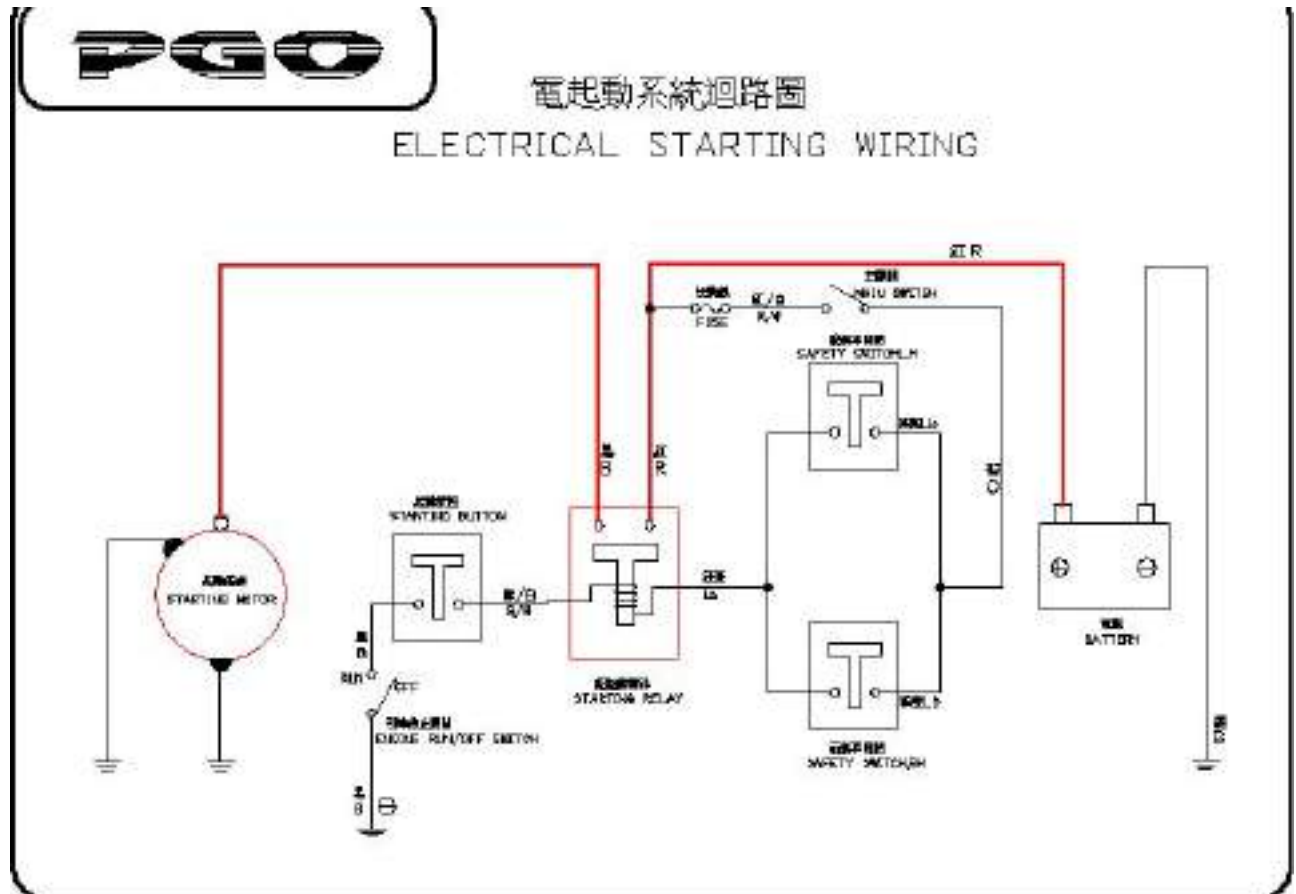

2.Make sure the Engine RUN/OFF switch is in “Run” position.

3.Check the safety switch by operating the brake lever, and the brake lamps shall light on.

#### 4. check the starting relay

a. Find the control coil by measuring the resistance.

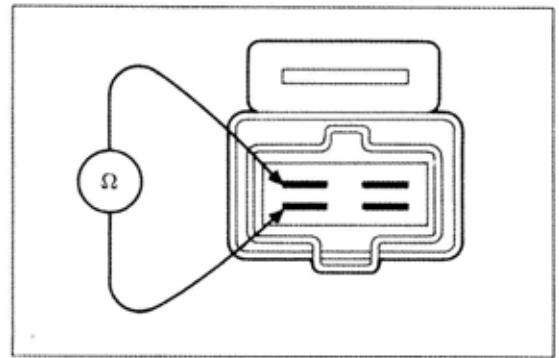

b. Connect green/white cable to positive pole of battery, connect black cable of negative pole of battery, It means starter is function well if above connection and both Red Black cable of starting motor have currency passing through.

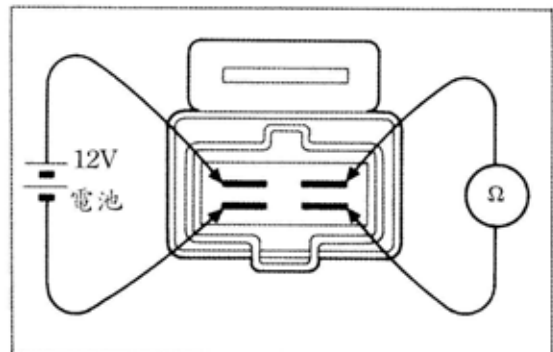

#### 3. Dismantling the starting motor

- (a) Remove 2 screws on starting motor.
- (b) Remove starting motor cables.



#### 4. Checking the starting motor

- Check the function by connecting the starting motor to battery.  
(Check if it is rotating counter clockwise)

Note: Do not operate starting motor for a long time.

■ Wiring diagram for M2-50

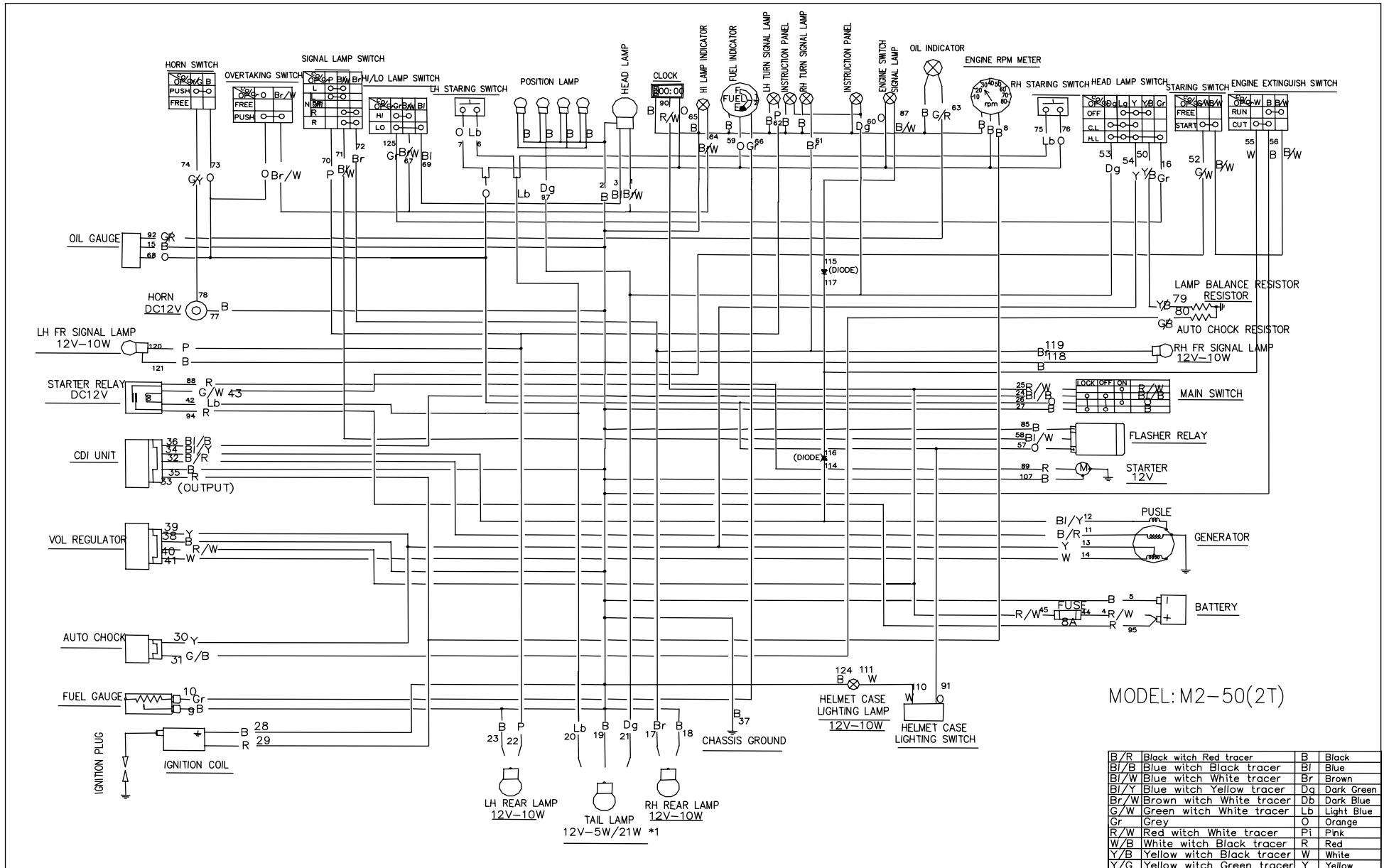

■ Wiring diagram for M2-125/150

