



Sales division
Technical network leadership

WORKSHOP MANUAL

VIVACITY 4T



50CC 4 STROKE









TABLE OF CONTENTS

TABLE OF CONTENTS.....	1
PRODUCTS DANGER SYMBOLS USED.....	3
CHARACTERISTICS.....	5
Engine.....	5
Capacities	5
Chassis	5
Dimensions and weight.....	6
Tyres	6
Brakes.....	6
SERVICE SCHEDULE AND COMMISSIONING.....	7
To be checked at each service.....	7
Service operations.	8
Time required for maintenance	8
Battery preparation (Except battery without maintenance)*	9
New machine preparation	9
SPECIAL IMPORTANT POINTS.....	10
Oil and fuel.....	10
TIGHTENING TORQUES	11
Engine part	11
Body panels	11
Cycle part.....	12
Standard	12
SPECIAL TOOLS	13
STANDARD TOOLS.....	13
LOCATION OF COMPONENTS.....	14
BODY PANELS	15
Location of body components	15
Body component sequence of disassembly.....	16
Removal of the rear storage compartment	17
Removal of the rear cover assembly and mudflap	17
Removal of the front storage compartment.....	19
Removal of the rear shield panel	19
Removal of the front shield panel.....	20
Removal of the footboard.....	21
Removal of the instrument cluster	22







SERVICE OPERATIONS.....	23
Changing the engine oil	23
Draining the relay box	24
Removal of the spark plug	25
Replacing the air filter	25
Transmission	26
Checking the drive pulley	27
Checking the drive belt	28
Checking the clutch linings.....	28
Replacing the clutch lining assembly	29
Installing the valve clearance	30
Idle setting.....	30
Removal of the fuel filter	31
Brake inspection	32
Replacing the brake pads	32
Rear brake linings	33
Checking the brake fluid level	33
Draining the front fork	36
MISCELLANEOUS OPERATIONS	38
Removal of the fork.....	38
Replacing the bearings of the steering system.....	38
Steering system tightening method.....	40
Changing the front fork seals	41
The fork and its components.....	43
ELECTRICITY.....	46
Ignition principle schematic/Carburetor heater	46
Temperature control unit/Regulator/Starter motor relay/Ignition unit	47
Checking the carburetor heating circuit.....	47
Checking the ignition system	48
Removal of the high tension coil	48
FUEL SYSTEM	49
Removal of the fuel pump	49
Removal of the fuel gauge	49
Removal of the fuel tank	50
Removal of the carburetor.....	51
The carburetor and its components	57
POWER UNIT	58
Removal of the power unit	58

PRODUCTS DANGER SYMBOLS USED

Protection of individuals and of the environment.

	Möbius band	Recyclable.	Means that the product or the package can be recycled. However, this does not guarantee that the product will be recycled.
	Irritant	The product can irritate the skin, eyes and respiratory organs.	Avoid contact with skin and clothes. Wear gloves, safety goggles and appropriate clothes such as a cotton overall. Do not breath fumes. If in contact, wash thoroughly with water.
	Flammable	The product is flammable.	Keep it away from any flame or heat source (barbecue, radiator, heating device, etc.). Do not leave the product in the sun.
	Corrosive	The product can damage living tissues or other surfaces.	Avoid contact with skin and clothes. Wear gloves, safety goggles and appropriate clothes such as a cotton overall. Do not breath fumes.
	Explosive	The product can explode under certain circumstances (flame, heat, impact, friction).	Avoid impacts, friction, sparks and heat.
	Hazardous to the environment	The product affects fauna and flora. Do not dump it in garbage cans, sinks or nature.	The ideal solution is to bring this product to your nearest household waste recycling centre.
	Toxic	The product can seriously affect health if it is inhaled, ingested or in contact with skin.	Avoid direct contact with the body, even by inhalation. If you feel unwell, seek medical advice immediately.
	Do not throw away into a garbage can	One of the product's component is toxic and can be hazardous to environment. i.e.: Used batteries.	This symbol informs the consumer that the used product shall not be thrown away into a garbage can, but shall be brought back to the merchant or dropped at a specific collection point.
	Compulsory gloves	Operation that can be dangerous for people.	People's safety can be seriously affected if the recommendations are not fully respected.

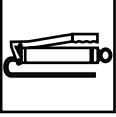
PRODUCTS DANGER SYMBOLS USED

	People's safety	Operation that can be dangerous for people.	People's safety can be seriously affected if the recommendations are not fully respected.
	Important	Operation that can be hazardous to the vehicle.	Indicate the specific procedures that shall be followed in order not to damage the vehicle.
	Good operating condition of the vehicle	The operation must be carried out in strict compliance with the documents.	Serious damage to the vehicle and in certain cases a cancellation of the warranty can be involved if the recommendations are not fully respected.
	Note	Operation that can be difficult.	Indicate a note which gives key information to make the procedure easier.
	Lubricate	Lubricate the parts to be assembled.	Indicate the specific procedures that shall be followed in order not to damage the vehicle.
	Grease	Grease the parts to be assembled.	Indicate the specific procedures that shall be followed in order not to damage the vehicle.
	Glue	Glue the parts to be assembled.	Indicate the specific procedures that shall be followed in order not to damage the vehicle.
	New part	Use a new part.	Indicate the specific procedures that shall be followed in order not to damage the vehicle.

CHARACTERISTICS**■ Engine**

Type	4-stroke single-cylinder 2 valves per cylinder with chain driven overhead camshaft
Cooling	By a circulation of forced air by means of a turbine on the flywheel magneto
Bore x stroke	37 x 46 mm
Cubic capacity	49.5 cc
Max. power output	2.8 kW at 8000 rpm
Max. torque rating	3.5 Nm at 6500 rpm
Compression	9.5 bars at 550 rpm
Fuel supply	Carburettor Keihin NCV18 (c/d)
Lubrication	Trochoid pump driven by a gear set from the crankshaft
Transmission	By 2 variable pulleys and V-type belt
Clutch	Centrifugal automatic
Exhaust	With catalytic system and pulsair valve
Starter motor	By kick starter or electric starter
Spark plug	NGK CR6HSA Electrode gap: 0.6 mm
Magneto flywheel	80 W

■ Capacities

Relay box	0.09 l SAE 80W90. Minimum grade: API GL4
Crankcase	0.7 l SAE 5W40. Minimum grade: API SL/SJ
Fork oil	0.085 l per tube (Esso Univis 46 or Agip HLift 46)
Fuel tank	8.5 l

■ Chassis

Chassis	Steel tube
Front suspension	Hydraulic telescopic fork Ø32 mm. Travel: 75 mm
Rear suspension	Combined spring and hydraulically-damped shock absorber Travel: 65 mm

■ **Dimensions and weight**

Overall length	1923 mm
Width at handlebar	670 mm
Height. (without rear-view mirrors)	1170 mm
Wheelbase	1353 mm
Saddle height	786 mm
Unladen weight	95 kg

■ **Tyres**

Front wheel rim	12 inch aluminium alloy
Front tyre	120/70 - 12
Front tyre pressure	1.8 bars
Rear wheel rim	12 inch aluminium alloy
Rear tyre	120/70 - 12
Rear tyre pressure	2 bars

■ **Brakes**

Front brake	Single disc type, hydraulic control
Disc diameter and thickness	200 mm - 3.5 mm
Rear brake	cable-controlled, single cam drum type
Brake drum diameter	110 mm
Brake lining thickness	4 mm

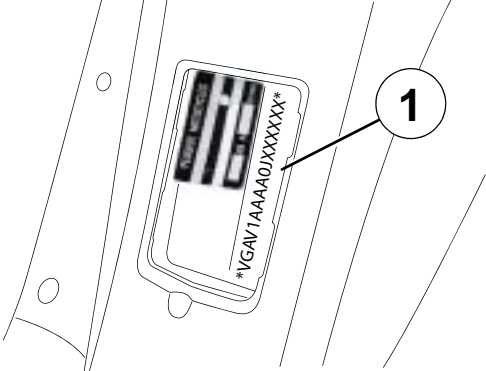
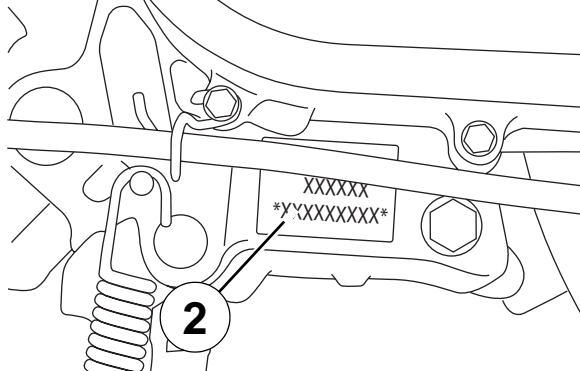
Chassis markings	Engine marking
 <p>(1) number and manufacturer's plate.</p>	 <p>Engine number (2).</p>

SERVICE SCHEDULE AND COMMISSIONING

Heavy duty servicing applies to vehicles used under rugged operating conditions: door-to-door deliveries, intensive urban use (courier), short journeys with engine cold, dusty areas, ambient temperature over 30°C.

Service operations	500	2000	5000	10000	15000	20000
Heavy duty servicing	500	1000	2500	5000	7500	10000
Minimum servicing	1 months	6 months	12 months	24 months	36 months	48 months

■ To be checked at each service

Steering column play.	V	V	V	V	V	V
Wheel bearing play.	C	C	C	C	C	C
Throttle cable play.	V	V	V	V	V	V
Operation of electrical equipment.	V		V	V		V
Condition of the front brake hydraulic control.	V	V	V	V	V	V
Brake fluid level.	V	V	V	V	V	V
Front brake pad wear.	C	C	C	C	C	C
Rear brake lining wear.	C	C	C	C	C	C
Condition of petrol pipes.	C	C	C	C	C	C
Tyre condition, pressure and wear.	C	C	C	C	C	C
Condition of the front suspension. Condition of the rear suspension.	V	V	V	V	V	V
Battery electrolyte level. Battery charge.	V	V	V	V	V	V
Engine oil level.	Every 1000 kms					
Headlight height adjustment.	V	V	V	V	V	V
Tightness of nuts and bolts.	V	V	V	V	V	V
Overall operation. Road test.	V		V	V		V

V: Check, clean, adjust.

R: Change.

G: Check, clean, lubricate.

N: Clean.

C: Inspect and change if necessary.

* Depending on equipment

Service operations	500	2000	5000	10000	15000	20000
Heavy duty servicing	500	1000	2500	5000	7500	10000
Minimum servicing	1 months	6 months	12 months	24 months	36 months	48 months

■ Service operations.

Spark plug.	V		R	R	R	R
Air filter				R		R
Intake silencer drain.	N		N	N	N	N
Drive pulley bearings and guides.			V	C	V	C
Transmission belt.				R		R
Driven pulley caged needle bearing.			G	G	G	G
Kick starter mechanism.				G		G
Valve clearances.		V	V	V	V	V
Setting the carburettor.				V		V
Joints (Central stand, Brake levers).			G	G	G	G
Petrol filter.						R
Engine oil (+ clean strainer).	R	R	R	R	R	R
Relay box oil.	R		R	R	R	R
Fork oil.						R
Petrol pipe.	Once every 5 years					
Brake fluid.	Once every 2 years					

■ Time required for maintenance

Code.	9100	9150	9300	9400	9500	9600
Servicing time in tenths of an hour. (0.5 h = 30 min).	1.2	2.1	3.3	3.9	3.3	4.2

V: Check, clean, adjust

R: Change.

G: Check, clean, lubricate.

N: Clean.

C: Inspect and change if necessary.

* Depending on equipment

■ Battery preparation (Except battery without maintenance)*

Remove the battery.

Remove the 6 filler caps and the vent plug.

Fill all the battery cells with electrolyte to the upper level shown on the battery "UPPER LEVEL".

Electrolyte: (35% sulfuric acid = 1.28 g/cm³).0.5 litre can P/N 739733

Leave the battery to stand for around half an hour.

Top up if necessary.

Charge the battery for at least 2 hours with a current of 0.4 A.

Refit the battery and connect the vapour vent pipe.

Connect the red wire lug to the battery's + terminal, and the green wire lug to the battery's - terminal.

Then, the battery level should be topped up if necessary, after fully charging, using distilled water only.

* Depending on equipment.

Installing the battery vapour vent hose.

- After being connected to the battery, the vapour vent hose must be routed through the 2 holders located in the rear splash guard.
- Cut the vent hose 1 cm after the second holder (1).

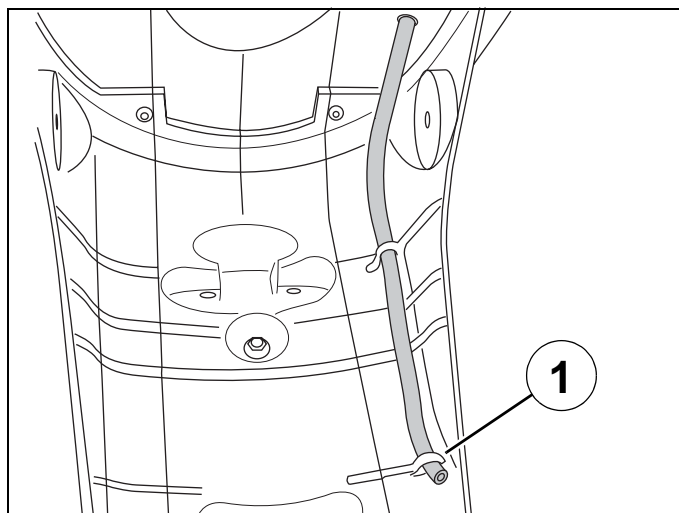

■ New machine preparation

Check the tightness of the carburettor float chamber drain screw.

Check the wheel nuts are tight.

Check nuts and bolts are tight.

Check brake adjustment and efficiency.

Check the tyre pressures cold.

Check operation of the lights, flashers, horn, and brake light.

Check the different warning lights work.

Carry out a road test.

SPECIAL IMPORTANT POINTS

■ Oil and fuel



This engine is designed to run on 95 or 98 unleaded fuel only.



Fuel pipes must absolutely be changed if there are any signs of wear, cracks, etc.

The air pipe between the air pump and the exhaust is specific owing to its heat resistance properties.

Should it be changed, replace it with a genuine pipe.

The clips are specific, they must always be changed each time they are removed and replaced with new genuine parts clips.



Petrol is highly inflammable, do not smoke in the working area and avoid proximity to flames or sparks.

Before carrying out any work, leave the engine to cool for at least 2 hours.

TIGHTENING TORQUES**■ Engine part**

Spark plug	12 Nm
Filler cap	20 Nm
Screen	15 Nm
Cylinder head	
• 6 mm diameter nut	20 Nm
• 6 mm diameter screw	12 Nm
Camshaft gear cover	10 Nm
Camshaft gear	20 Nm
Valve clearance covers	15 Nm
Automatic tensioner	10 Nm
Automatic tensioner plug	8 Nm
Chain tensioner	10 Nm
Inlet manifold	10 Nm
Crankcase	12 Nm
RH casing cover	12 Nm
Freewheel	90 Nm
Oil pump	10 Nm
Transmission cover	10 Nm
Relay box cover	22 Nm
Relay box drain plug	10 Nm
Starter motor	10 Nm
Rotor	40 Nm
Turbine	10 Nm
Stator	10 Nm
Engine speed sensor	10 Nm
Drive pulley	55 Nm
Driven pulley	55 Nm
Clutch plate and shoes	55 Nm

■ Body panels

Front mudguard	8 to 10 Nm
Handlebar cover	2 to 4 Nm
Front shield panel	2 to 4 Nm
Rear shield	2 to 4 Nm
Bottom panel	2 to 4 Nm
Floor panel	6 to 8 Nm
Saddle storage compartment	8 to 10 Nm
Rear panels	6 to 8 Nm
Grab handle	20 to 25 Nm
Rear mudguard	2 to 4 Nm

■ Cycle part

Front wheel spindle	65 Nm
Rear wheel spindle nut	120 Nm
Linkrod to engine pivot	60 Nm
Linkrod to frame pivot	60 Nm
Shock absorber top mount	45 Nm
Shock absorber bottom mount	25 Nm
Exhaust to cylinder mounting nut	15 Nm
Exhaust to casing mounting bolt	30 Nm
Upper cone (in 2 operations)	40/23 Nm
Upper cone locknut	Hand tightened
Steering locknut	70 Nm
Front brake caliper	25 Nm
Front brake disc	30 Nm
Handle bar	25 Nm

■ Standard

Nut and bolt 5 mm diameter	5 Nm
Nut and bolt 6 mm diameter	10 Nm
Nut and bolt 8 mm diameter	22 Nm
Nut and bolt 10 mm diameter	35 Nm
Nut and bolt 12 mm diameter	55 Nm

SPECIAL TOOLS

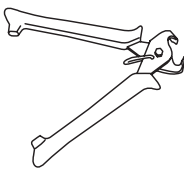
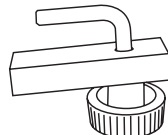
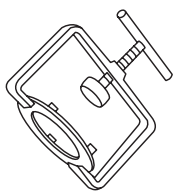
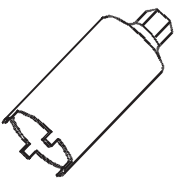
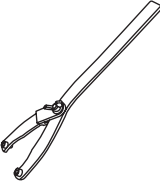
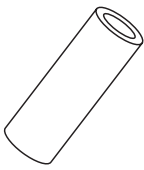
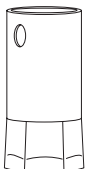
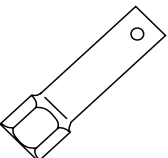
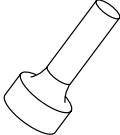
	Tool N°	Designation	Used with		Tool N°	Designation	Used with
	750539	Tie-wrap pliers			755996	Hose clamp	
	752127	Clutch compression tool	752361		757860	Steering tool	
	752237	Adjustable pin wrench			757990	Steering head cup push tool	
	752361	39 mm pipe wrench	752127		766062	Spark plug spanner	
	753726	Steering head cup push tool					

STANDARD TOOLS

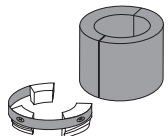
	Lip seal insertion kit for fork tube diameter 30 mm to 45 mm Type: Marolotest 601055
---	---

LOCATION OF COMPONENTS

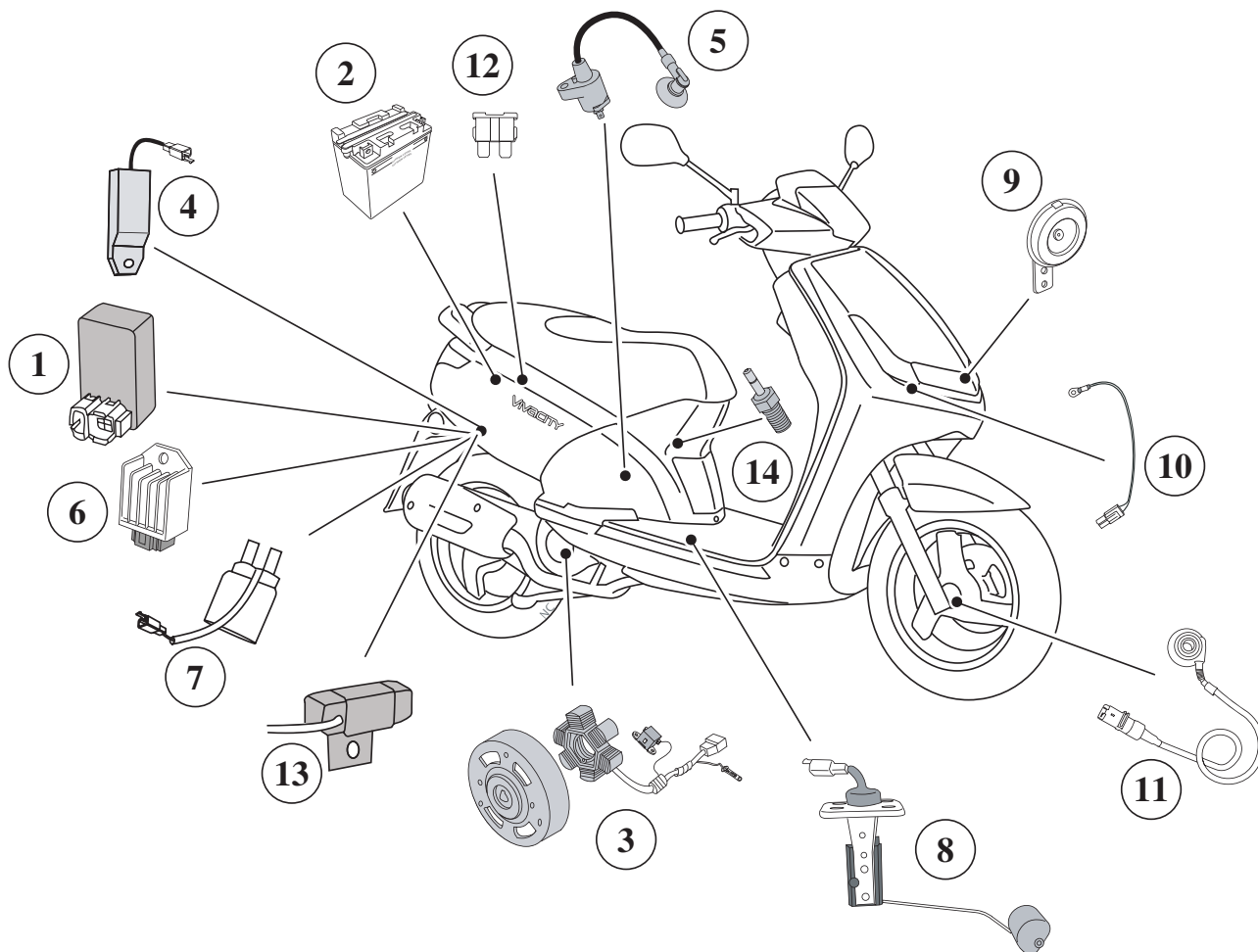

- | | |
|------------------------------|----------------------------------|
| 1. CDI unit. | 8. Fuel gauge. |
| 2. Battery. | 9. Horn. |
| 3. Ignition sensor. | 10. Outside temperature sensor. |
| 4. Temperature control unit. | 11. Speed sensor. |
| 5. HT coil. | 12. Fuse. |
| 6. Regulator. | 13. Starter resistor. |
| 7. Starter motor relay. | 14. Resistor warming carburator. |

BODY PANELS**■ Location of body components**

Description.

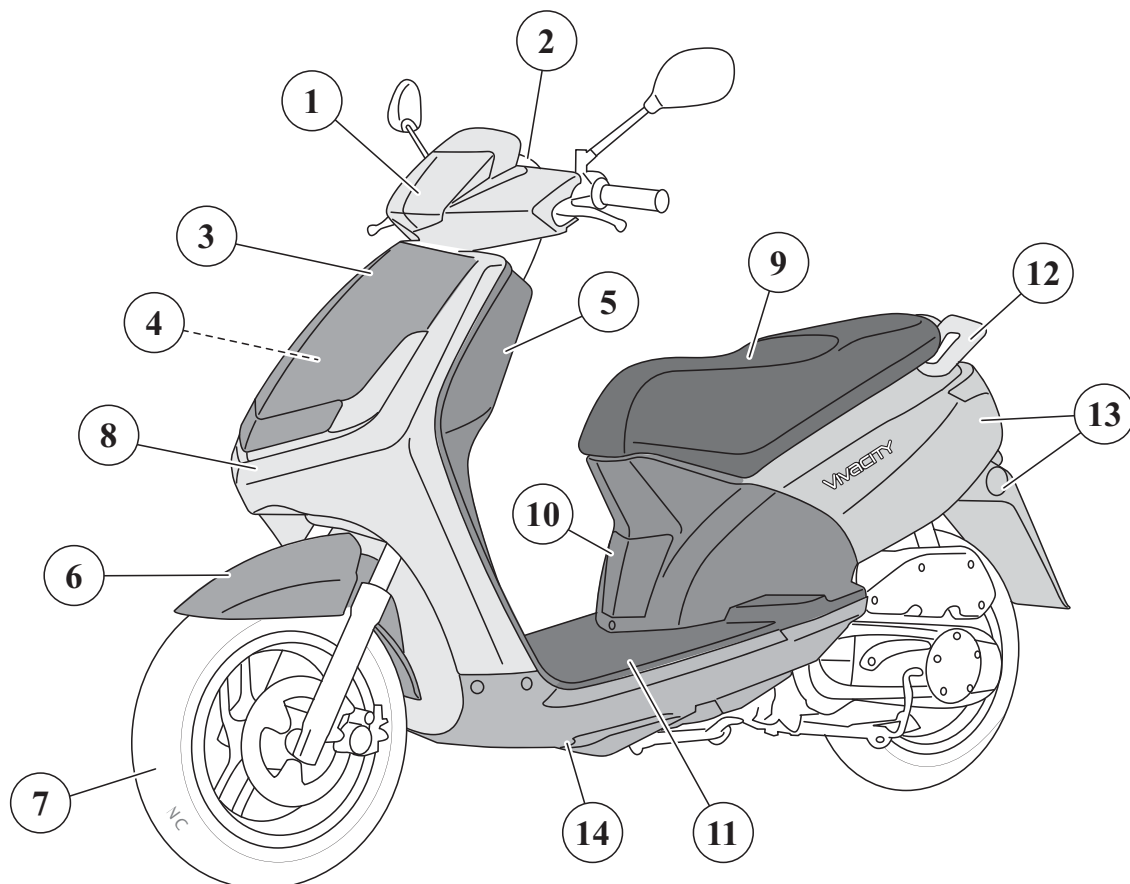

- | | |
|-------------------------------|------------------------------------|
| 1. Handlebar front fairing. | 8. Front shield panel. |
| 2. Handlebar rear fairing. | 9. Saddle and storage compartment. |
| 3. Tool compartment cover. | 10. Central panel. |
| 4. Front storage compartment. | 11. Footboard. |
| 5. Rear shield. | 12. Grab handle. |
| 6. Front mudguard. | 13. Rear panels. |
| 7. Front wheel. | 14. Bottom panel. |

■ Body component sequence of disassembly

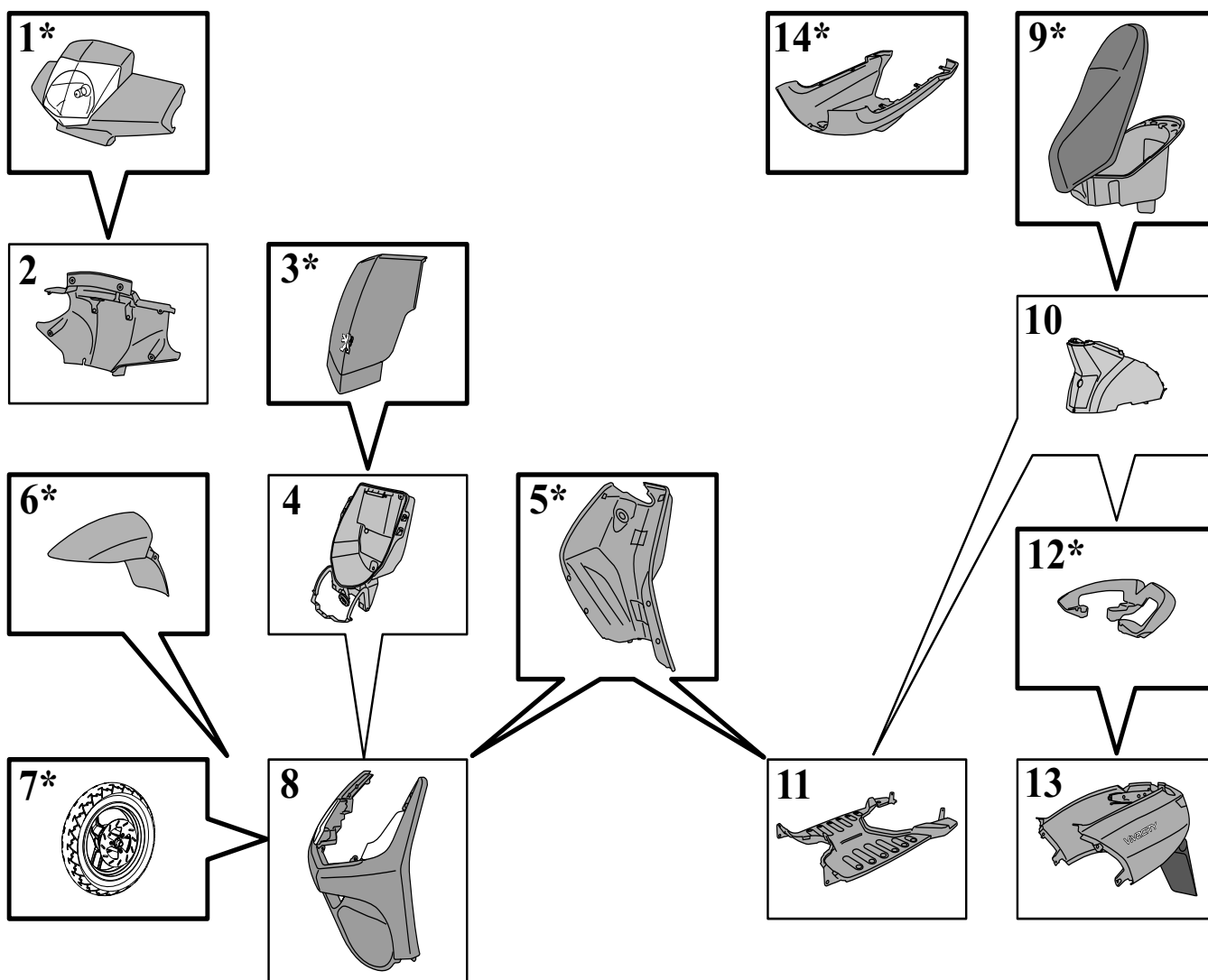

- 1. Handlebar front fairing.
- 2. Handlebar rear fairing.
- 3. Tool compartment cover.
- 4. Front storage compartment.
- 5. Rear shield.
- 6. Front mudguard.
- 7. Front wheel.

- 8. Front shield panel.
- 9. Saddle and storage compartment.
- 10. Central panel.
- 11. Footboard.
- 12. Grab handle.
- 13. Rear panels.
- 14. Bottom panel.

* This item may be removed on its own.

■ Removal of the rear storage compartment

Procedure 1.

- Lift the saddle.
- Remove the storage compartment (8 screw).
- Disconnect the accessory plug.

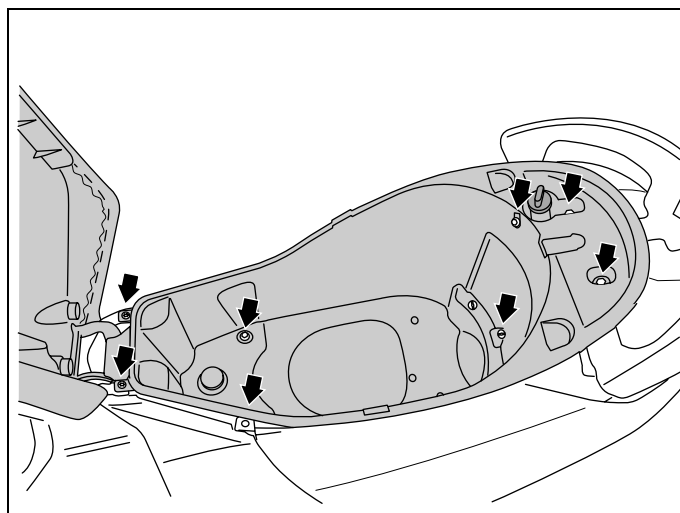

■ Removal of the rear cover assembly and mudflap

Procedure 2.

- Remove the rear storage compartment. See: Procedure 1 page 17.
- Remove the grab handle (3 screw). (1)

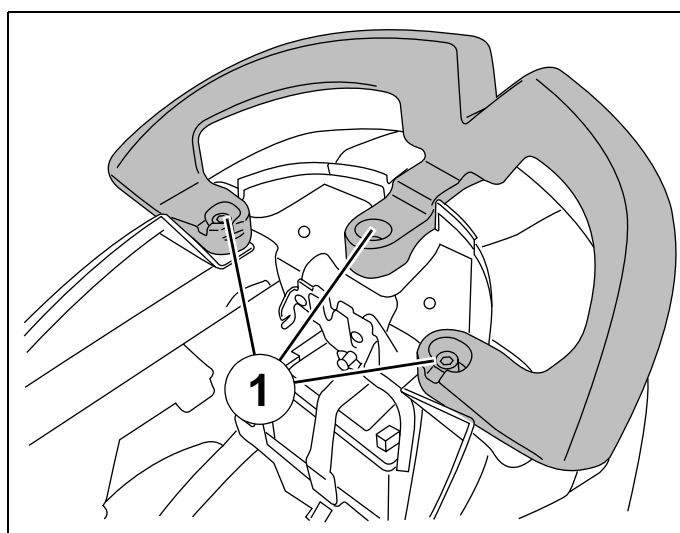

- Remove the central cover panel (5 screw).

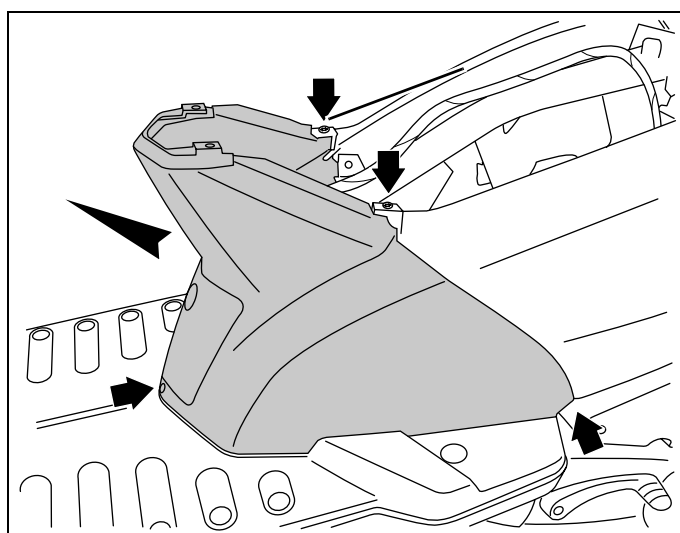

- Remove the rear cover assembly (5 screw) (3).
- Disconnect the taillights.

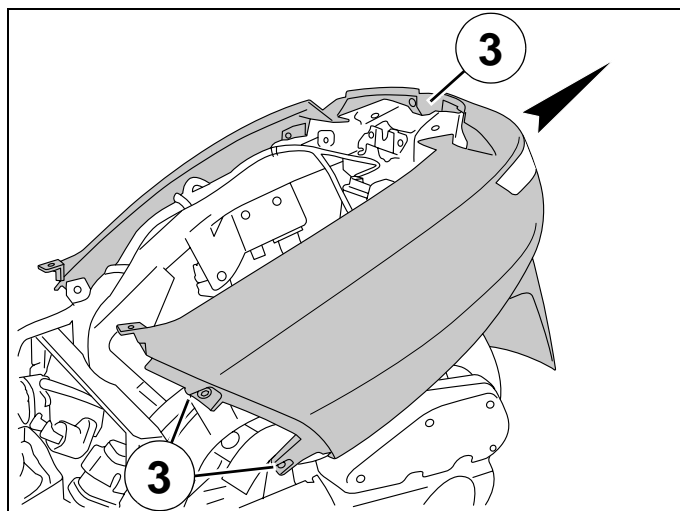

- Remove the splash guard. (6 screw)
- Separate the 3 fairings. (4)

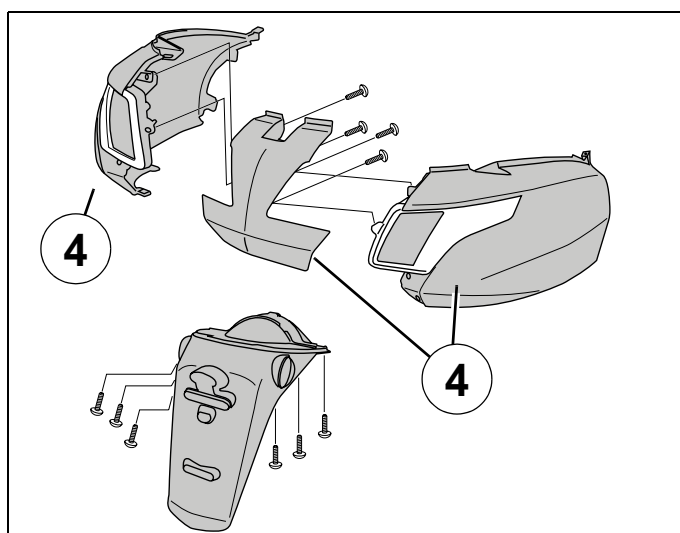

■ Removal of the front storage compartment

Procedure 3.

- Remove the storage compartment lid (5 screw).

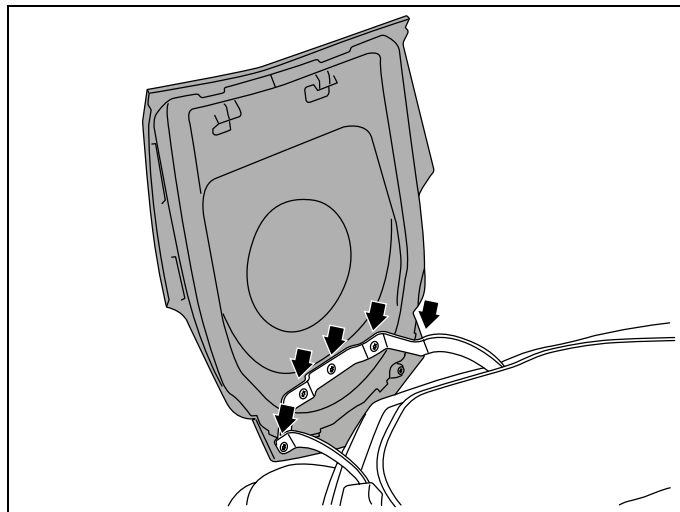

- Remove the storage compartment (11 screw).
- Disconnect the horn.

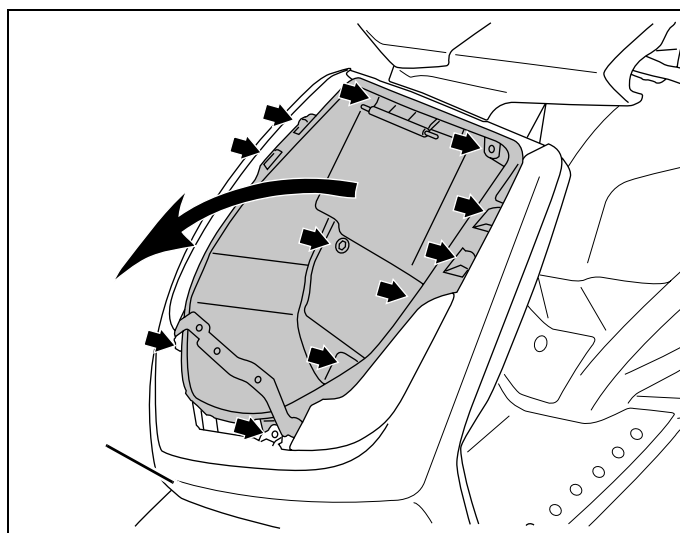

■ Removal of the rear shield panel

Procedure 4.

- Remove the 4 upper screws that secure the rear shield panel.

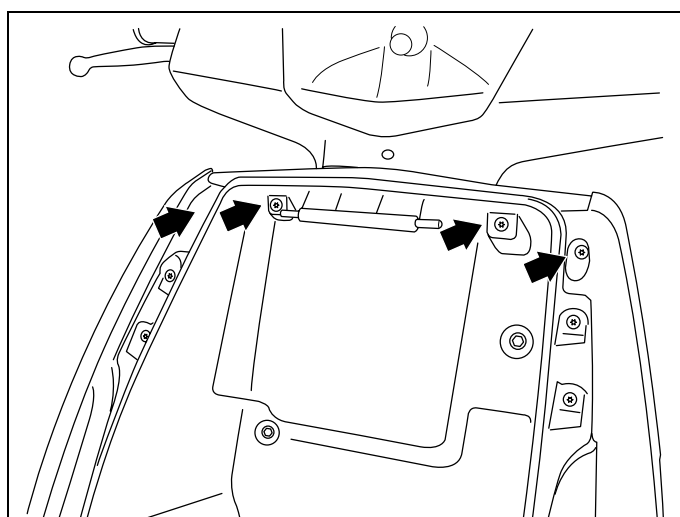

- Remove the 7 screws that secure the rear shield panel.
- Remove the rear shield panel.

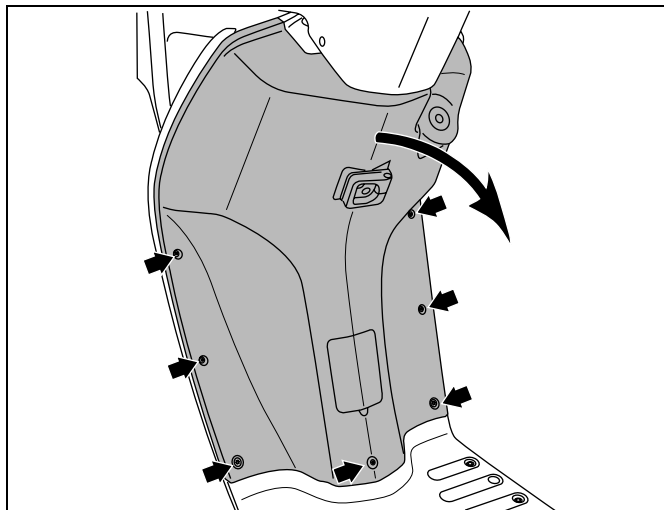

■ Removal of the front shield panel

Procedure 5.

- Remove the front storage compartment. See: Procedure 3 page 19.
- Remove the rear shield panel. See: Procedure 4 page 19.
- Remove the wheel spindle nut.

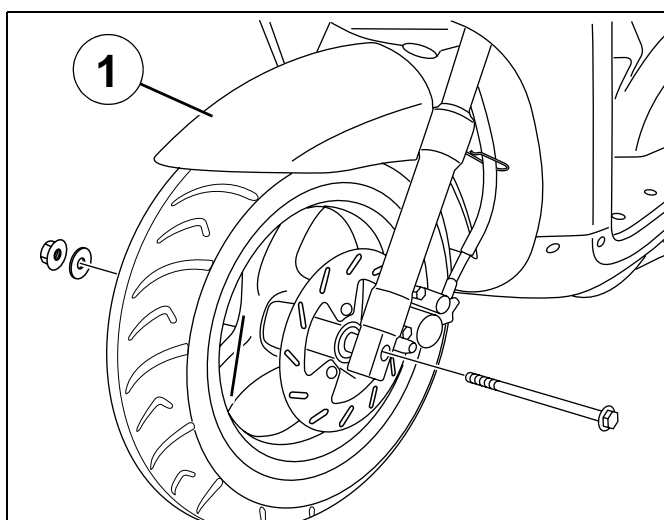

N	When re-installing, use a new nut.
----------	---

- Remove the front wheel.
- Remove the front mudguard (1) (4 screw).
- Remove the 5 screws that secure the front shield panel.

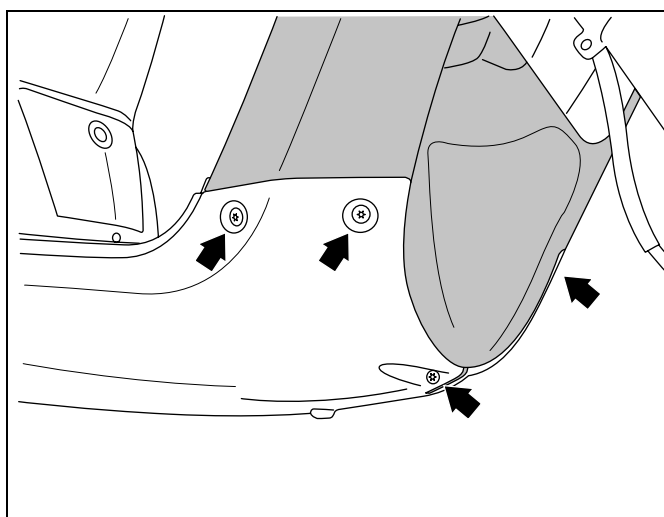

- Disconnect the direction indicators.
- Disconnect the outer temperature sensor.
- Remove the 6 screws that secure the front shield panel.
- Unclip the mud splash guard from the front leg shield panel.
- Remove the front shield panel.

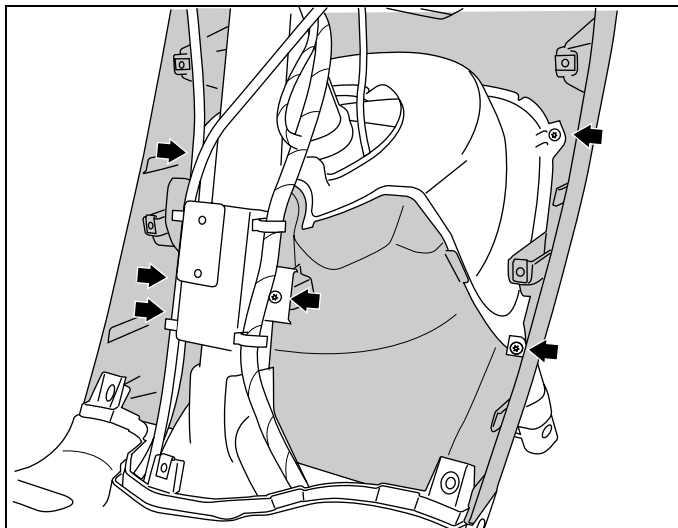

■ **Removal of the footboard**

Procedure 6.

- Remove the rear storage compartment. See: Procedure 1. page 17.
- Remove the central cover panel (5 screw).
- Remove the rear shield panel. See: Procedure 4. page 19.
- Remove the bottom panel (14 screw).

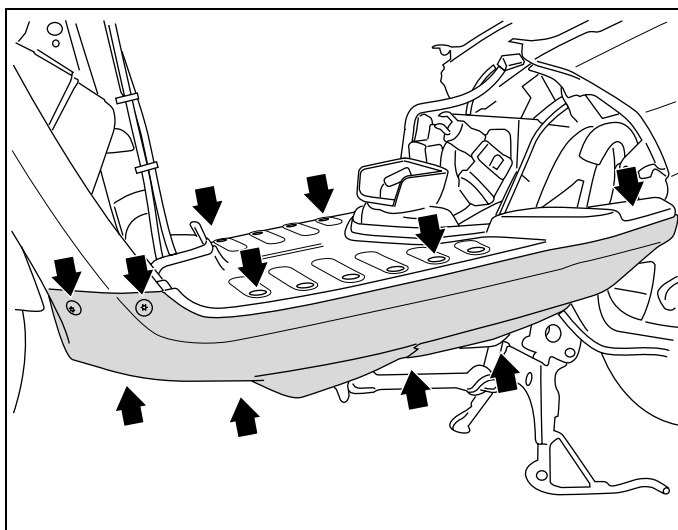

- Remove the footboard (4 screw).

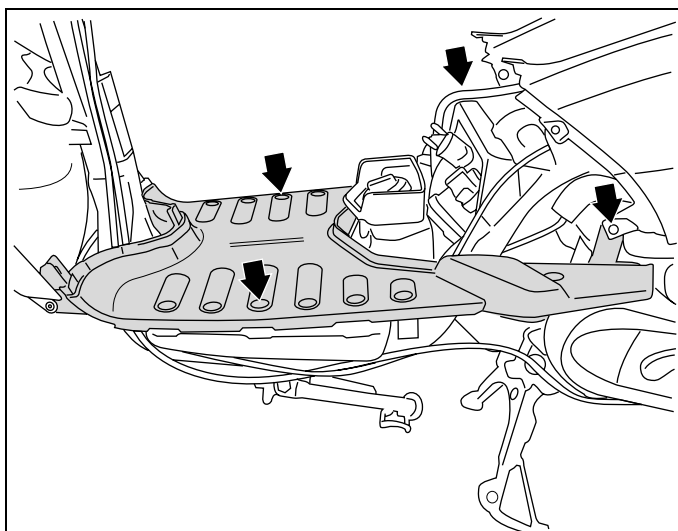

■ **Removal of the instrument cluster**

- Remove the handlebar front cover (6 screw).

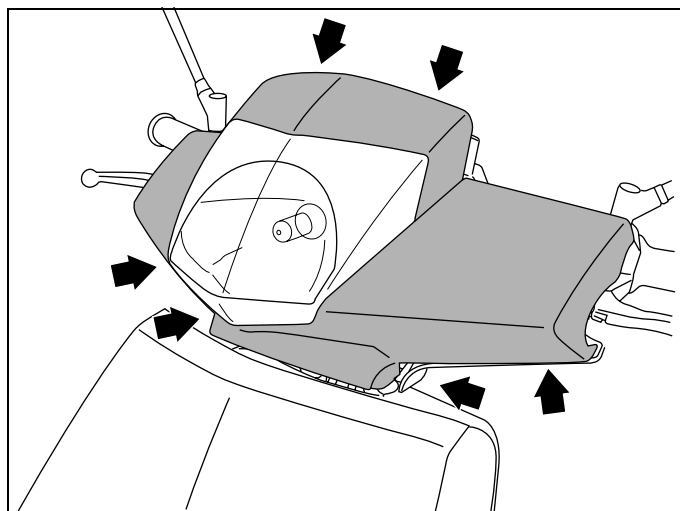

- Disconnect the instrument cluster.
- Remove the handlebar rear cover and instrument cluster assembly (4 screw).
- Remove the instrument cluster (4 screw).

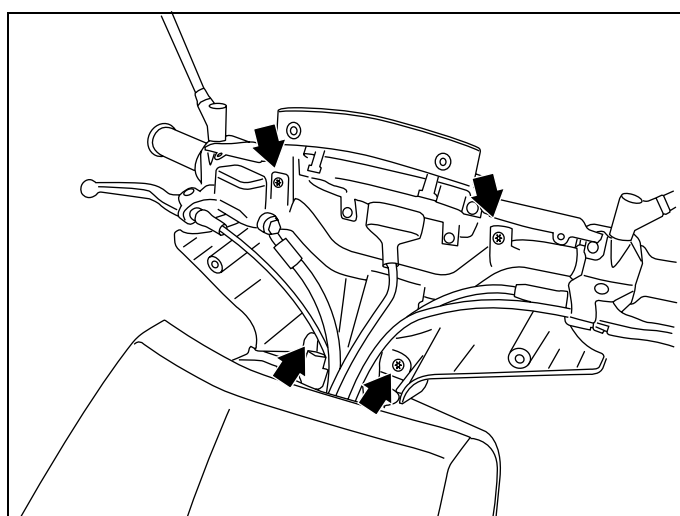

SERVICE OPERATIONS

■ Changing the engine oil



The engine must be drained when it is warm to allow the oil to run easier.
Put on protective gloves.

- Place the vehicle on its central stand on flat ground.
- Remove the engine's oil filler cap (1).

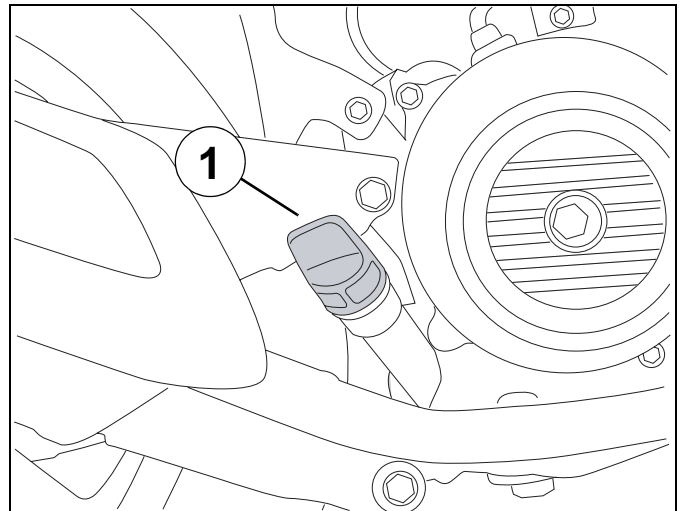

Remove the drainage cap and its seal (2) and allow the oil to drip into a recipient.

- Remove the strainer cap (3) and clean the strainer.
- Re-install the filter cap fitted with a new seal.

Tightening torque: 15 Nm.

- Insert the drain plug fitted with a new seal.

Tightening torque: 20 Nm.

- Pour the required quantity of oil corresponding to the manufacturer's standards into the filler hole.

Quantity: 0.7 l.

- Start the engine and let it run for a short while.

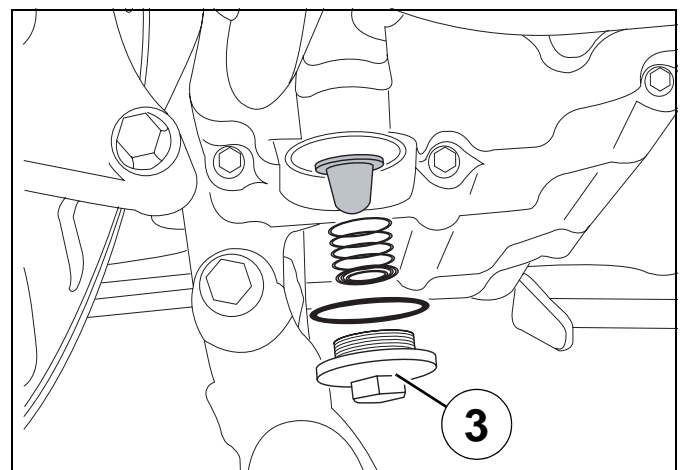
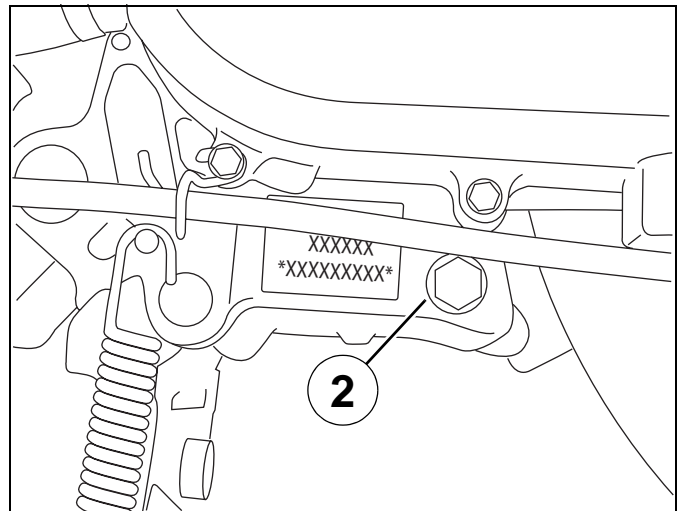

- Remove the engine's oil filler cap/gauge.
- Wipe dry the filler cap/gauge and fit it back but do not screw it into the filler hole.
- Remove the filler cap/gauge and check the oil level.
- The oil level shall not be between the minimum (A) and maximum (B) level marks without exceeding the latter.
- Add oil if necessary.

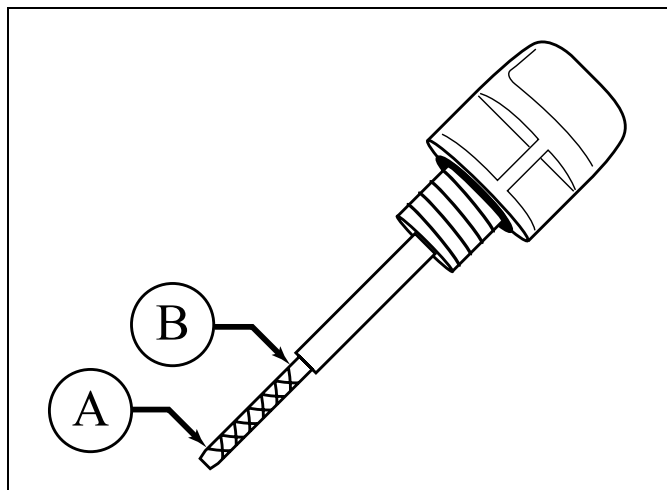

■ Draining the relay box



The gearbox must be drained when the engine is warm so that the oil will run easier.
Put on protective gloves.

- Place the vehicle on its central stand on flat ground.
- Remove the relay box filler cap.
- Remove the drainage cap and its seal (1) and allow the oil to drip into a recipient.
- Insert the drain plug fitted with a new seal.

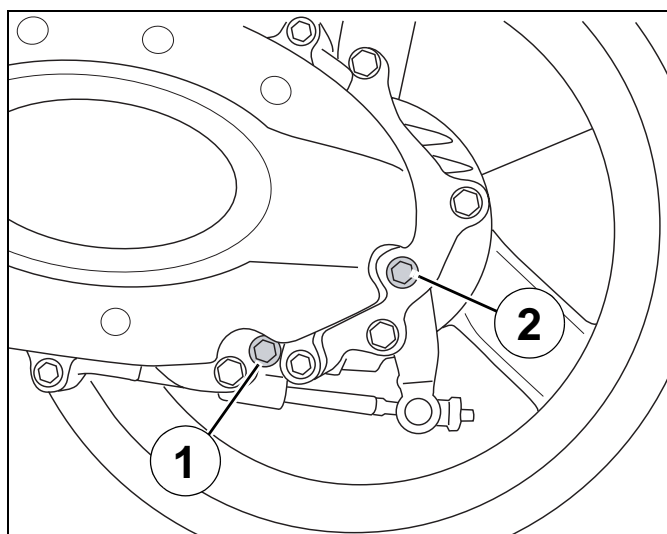

Tightening torque: 10 Nm.

- Pour the required quantity of oil corresponding to the manufacturer's standards into the filler hole.

Quantity: 0.1 l.

- Fit the filler cap (2).

Tightening torque: 10 Nm.

■ **Removal of the spark plug**

- Remove the rear storage compartment. See: Procedure 1. page 17.
- Disconnect the suppressor (1).
- Remove the spark plug using tool P/N 766062.

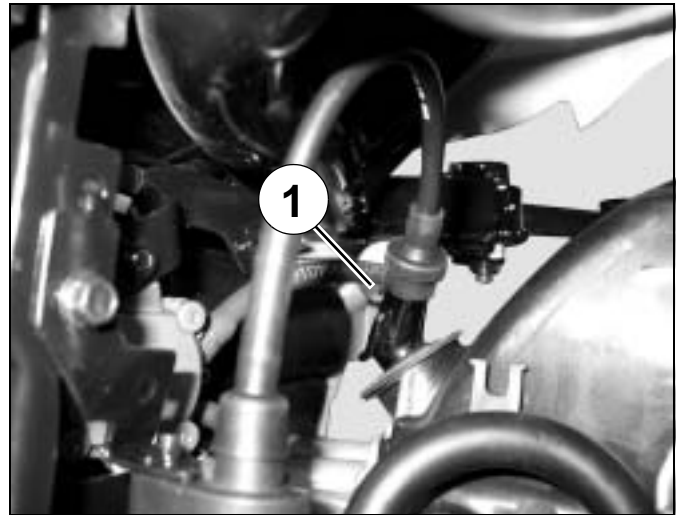

Essential precautions: When re-installing, screw in the spark plug (a few turns) by hand.

- Tighten the spark plug.

Tightening torque: 12 Nm.

■ **Replacing the air filter**

- Remove the air filter cover (7 bolts) and its seal.

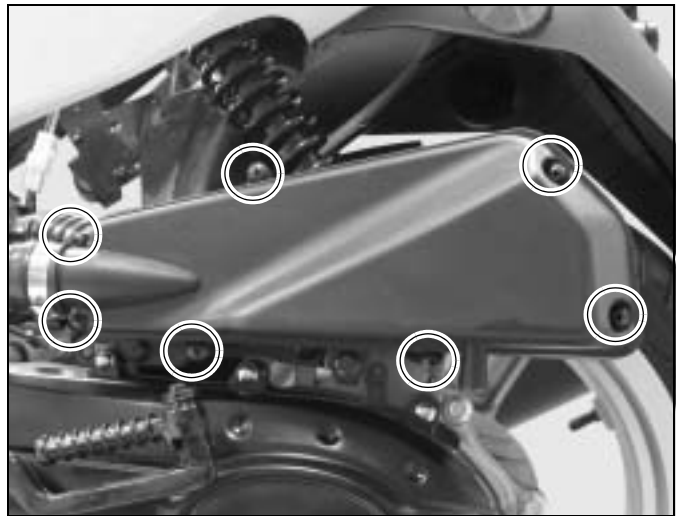

- Remove the air filter (1).
- Clean inside the air filter box.

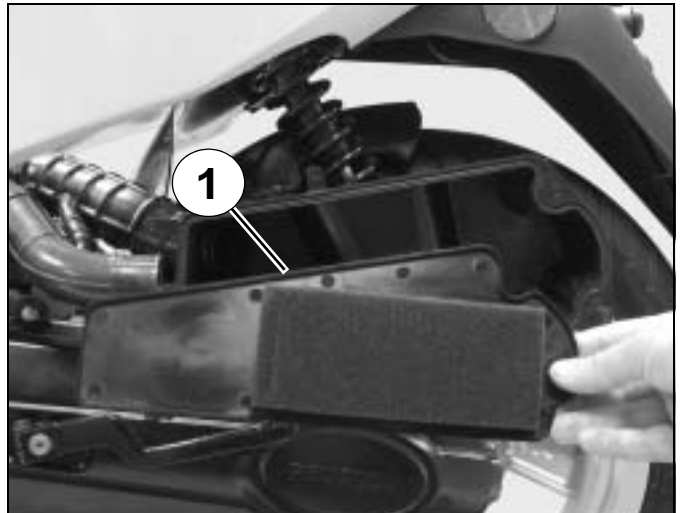

	<p>Fit a new air filter.</p>
	<p>Check the condition of the seals and make sure they are properly positioned.</p>

- Install the air filter cover.

- Remove the inlet silencer drain plug to let humidity and oil drip out (2).

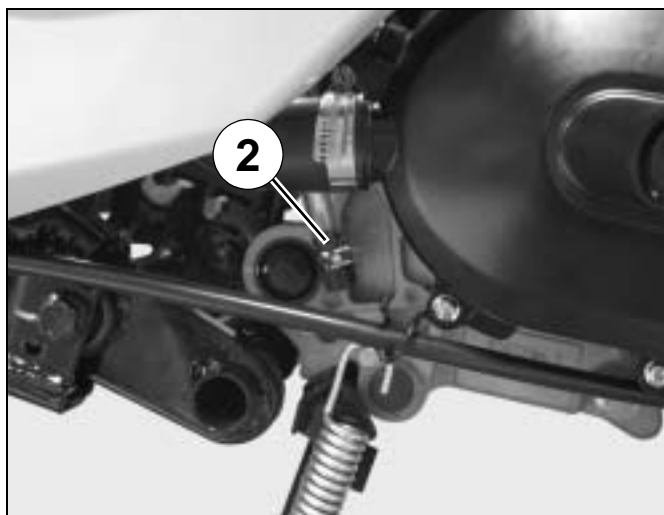

■ **Transmission**

- Remove the transmission cover (10 screw).
- Remove the paper gasket.

	<p>Install a new paper gasket.</p>
---	---

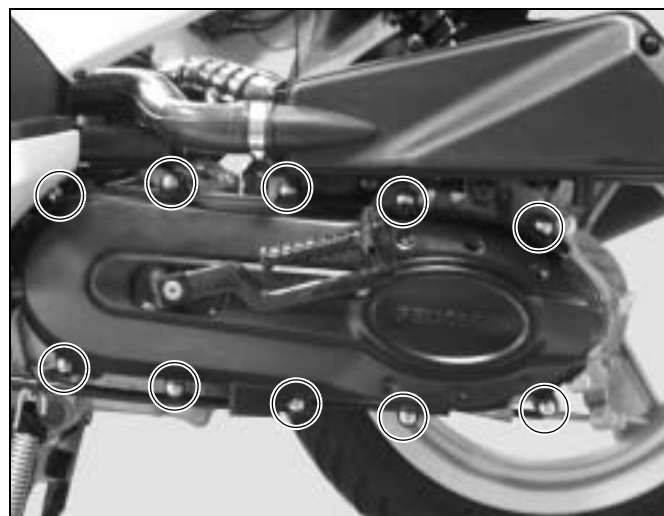

- Hold the fixed flange with tool P/N 752237.
- Remove the fixed flange nut and washer.

Tightening torque: 55 Nm.

- Remove the ribbed washer.
- Remove the fixed flange.

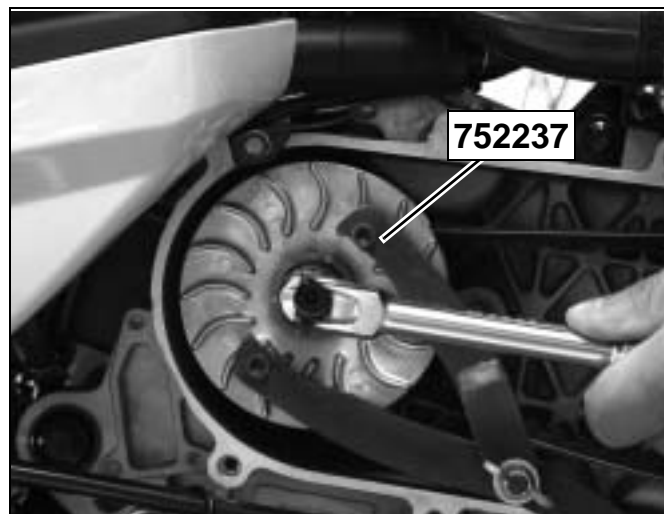

- Remove the belt.
- Remove the drive pulley (1) together with the guide hud.

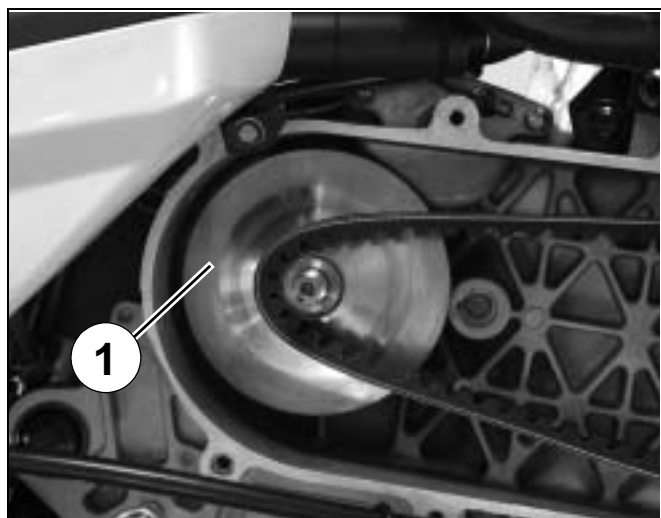

- Lock the clutch drum with the pin wrench P/N 752237.
- Remove the clutch drum and the clutch and drive pulley assembly.

Tightening torque: 55 Nm.

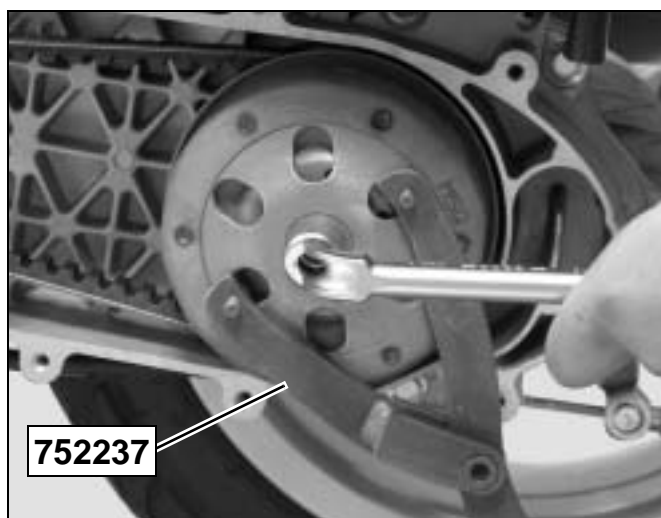

■ Checking the drive pulley

- Remove the holder (2) and its 3 plastic guides.
- Remove the moving flange (4) 6 bearings (3).
- The bearings must be changed if they show major signs of wear.
- The guides shall be replaced if they show signs of wear.

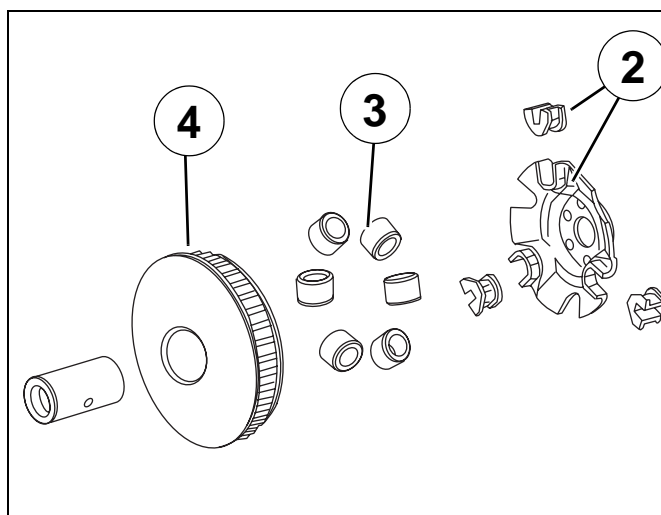

- When refitting, respect the way the rollers are installed.
- Grease the moving flange bore lightly (high temperature grease).

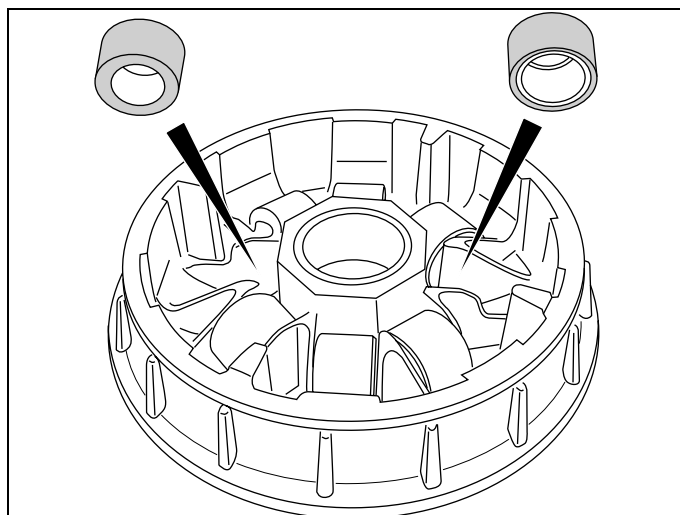

■ **Checking the drive belt**

Measure the width of the belt (A).

Minimum width: 17.2 mm.

Make sure the belt is not cracked.

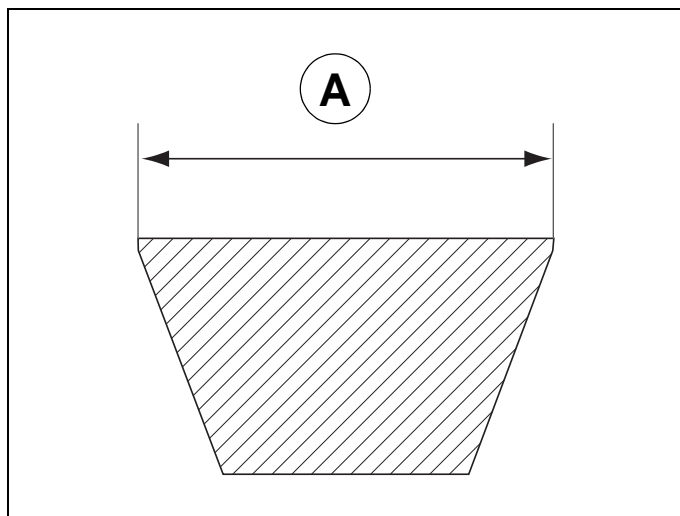

■ **Checking the clutch linings.**

- Using the depth calliper, measure the thickness of the clutch linings.

Mini. thickness 2 mm.

- Make sure surface of the plates in contact with the belt does not show any cracks or signs of abnormal wear.

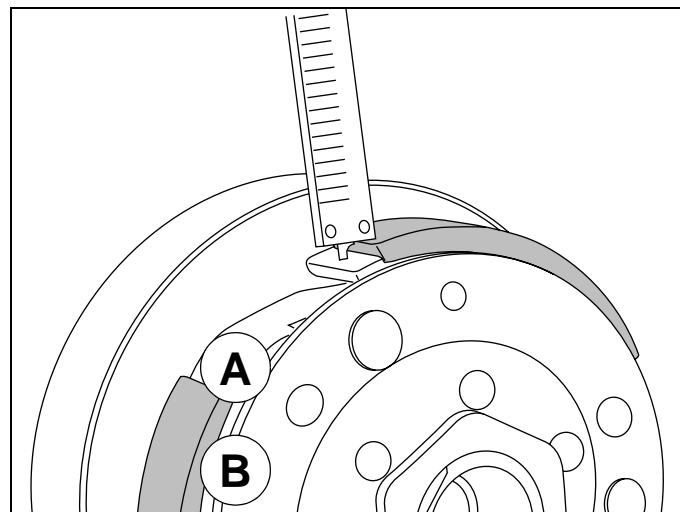

■ Replacing the clutch lining assembly

- Compress the clutch drive pulley and driven pulley assembly with the tool P/N 752127 clamped in the jaws of a vice
- Remove nut (1) using spanner P/N 752361.

Tightening torque: 55 Nm.

- Slacken tool P/N 752127.

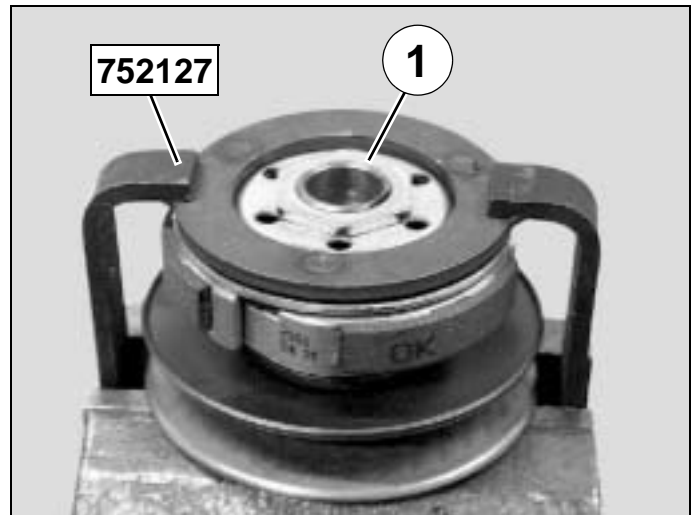

- Remove the clutch lining assembly (2).
- When re-installing the driven pulley, lubricate the needle bearing (3).

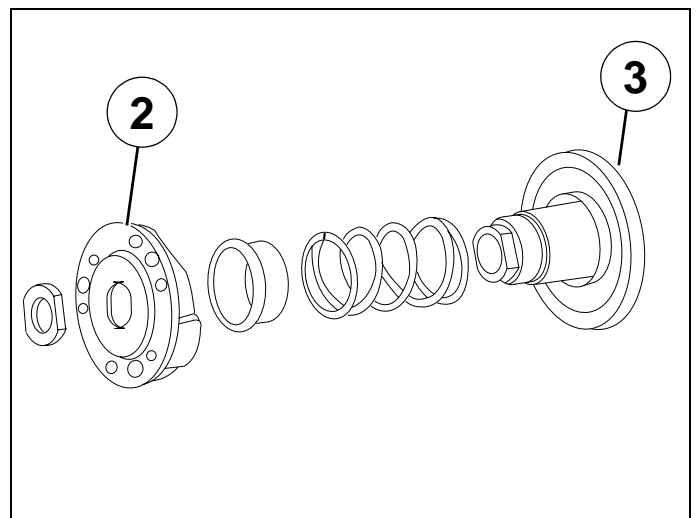

■ **Installing the valve clearance**

- Remove the power unit (see page 54).
- Remove the valve clearance adjustment covers.



Reassembly: Apply the correct tightening torque to the valve clearance adjustment covers.

Tightening torque: 15 Nm.

- Rotate the engine manually in the direction of operation in order to bring the rocker pads over the cam lobes (A).
- Using the set of feeler gauges, measure the clearance of each valve.
- Clearances:
 - **0.05 ±0.02 at the intake.**
 - **0.10 ±0.02 at the exhaust.**
- If the clearance is not correct, adjust by means of the cam follower screw.

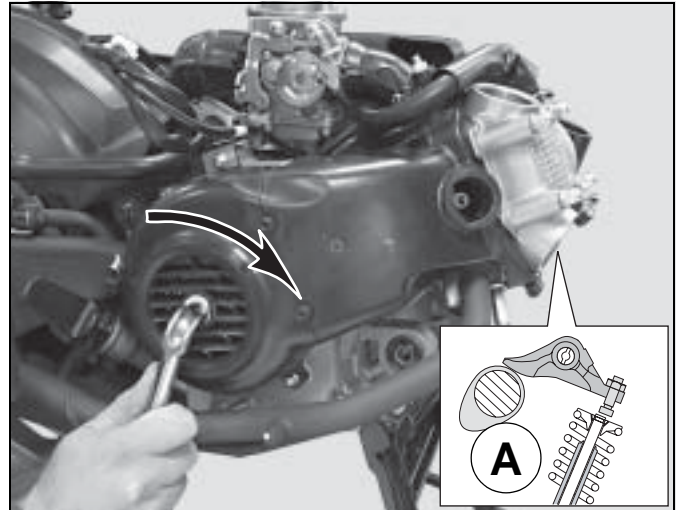

■ **Checking the valve clearance**

- At the intake a 0.10 mm feeler gauge shouldn't go.
- At the exhaust a 0.15 mm feeler gauge shouldn't go.
- On the contrary, if the feeler gauge goes, reset the clearances.

■ **Idle setting**

- Remove the rear storage compartment. See: Procedure 1. page 17.
- The engine must be at its operating temperature.
- Switch off the engine.
- Park the vehicle on its stand.
- Check the operating clearance in the throttle.
- Start the engine.
- Screw or unscrew the engine speed adjuster screw (1) to alter the idle speed.
- The rear wheel should not turn.

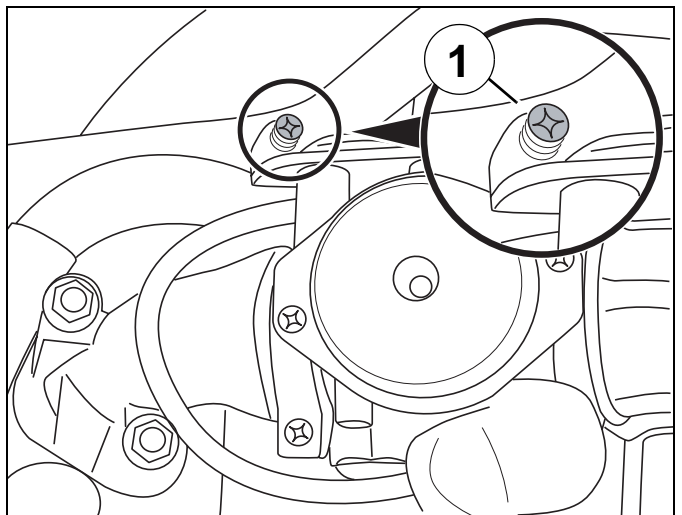

Idle speed: 1500 to 1700 rpm.

■ Removal of the fuel filter

- Remove the rear storage compartment.
See: Procedure 1 page 17.
- Remove the central cover panel (5 screw).
- Remove the RH under body panel (9 screw).
- Clamp the end of the fuel inlet pipe using a clip ref. 755996 (1).
- Disconnect the fuel inlet pipe (2).
- Remove the fuel filter (3).

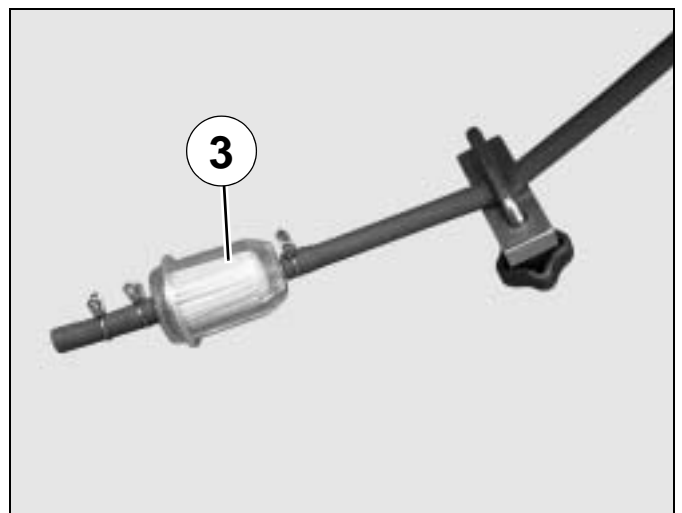
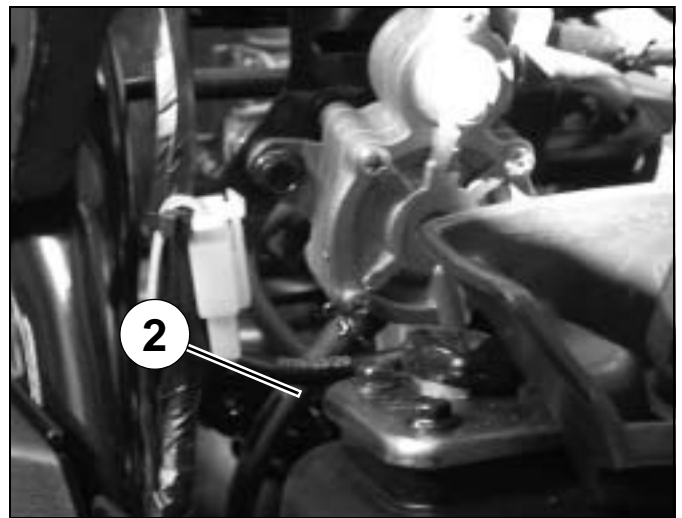
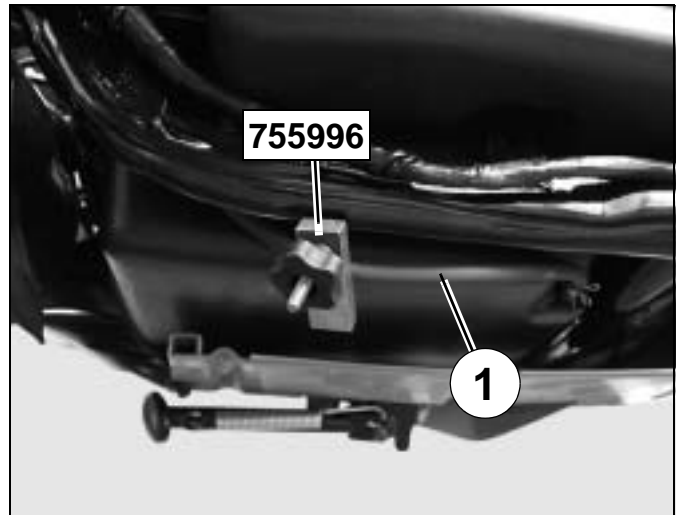

- Remove the fuel filter (3).



When re-installing, respect the direction of installation of the filter shown by the arrow which indicates in which direction the fuel flows.

■ **Brake inspection**

- If one of the 2 brake pads is worn down to the minimum dimensions (A), the 2 brake pads must be changed.

A. Mini. thickness: 1.5 mm.

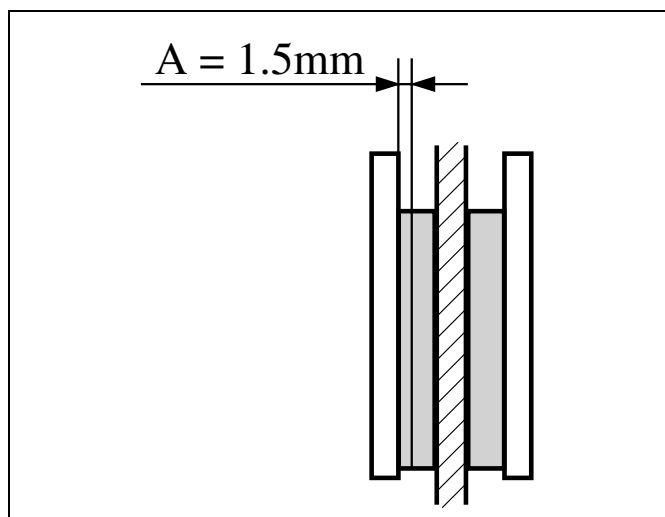

■ **Replacing the brake pads**



- Remove the calliper (2 screw).

Tightening torque: 25 Nm.

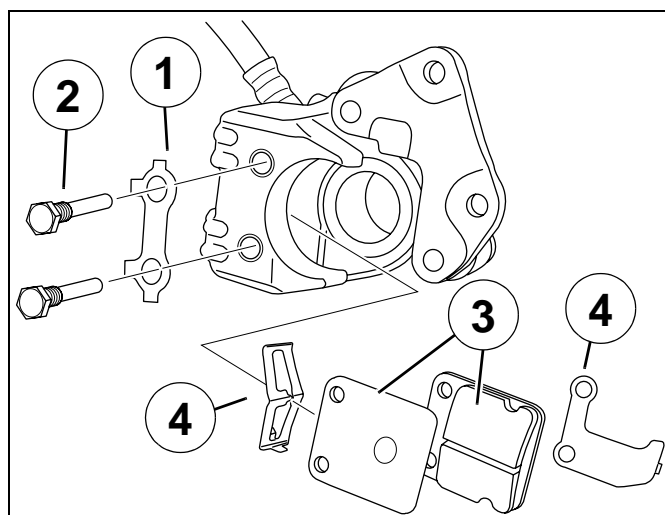

- Straighten the retainer in order to release the 2 pins (1).
- Remove the 2 pins (2).
- Remove the brake pads (3) and the anti-vibration plates (4).



	<p>When refitting the brake pads, push the pistons all the way into their housing.</p>
	<p>When re-installing, use a new pin retainer.</p>
	<p>After refitting, actuate the brake levers several times to bring the brake pads against the brake disc.</p>

■ Checking the brake fluid level

- Position the handlebars so that the master cylinder will be horizontal.
- Check the brake fluid level and if necessary top up in the master cylinder.

A. Maximum brake fluid level.

B. Minimum brake fluid level.

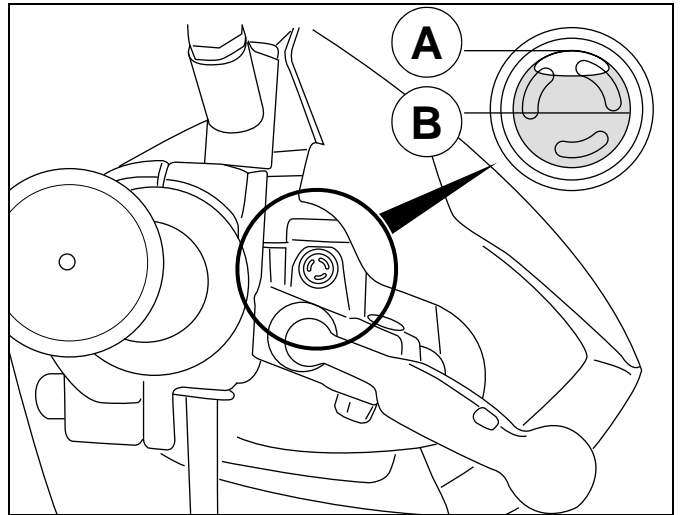

- Remove the handlebar front cover (6 screw).
- Remove the cover and the diaphragm from the master cylinder (2 screw).
- Add brake fluid until it reaches the maximum level.

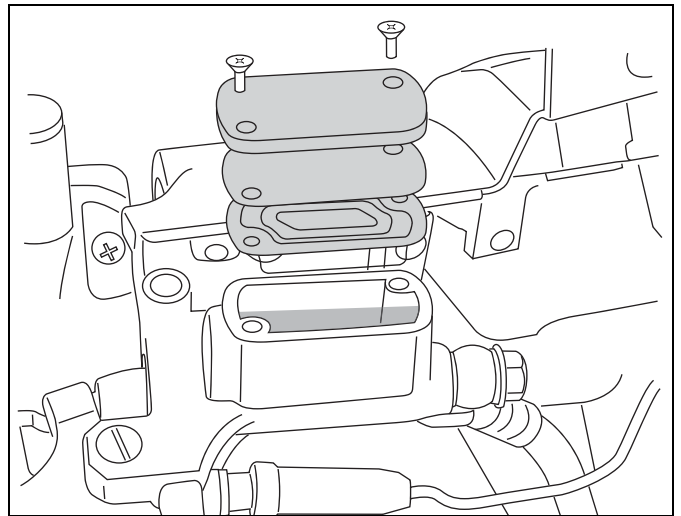

■ Rear brake linings

- Actuate the brake control lever and check the position of the wear mark on the cam tierod (A) compared to the mark (B) on the engine housing.
- If the cam tierod mark is lined up with or passes the wear mark on the engine housing, the brake lining must be replaced.
- When it is no longer possible to adjust the control tension nut, the brake pads are worn.

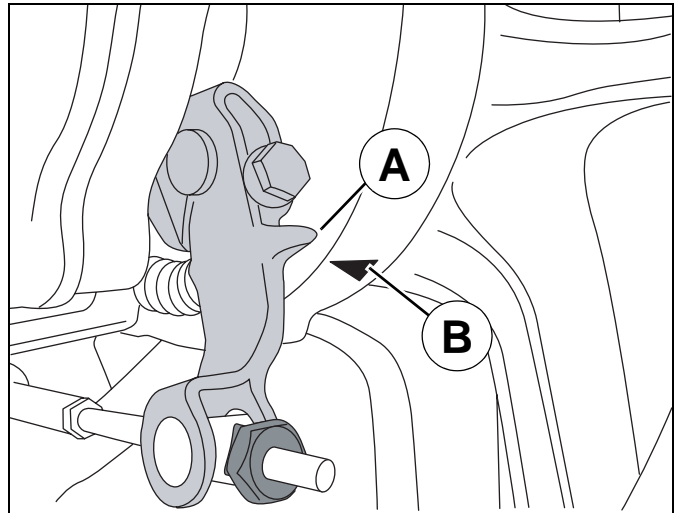

Disassembly.

- Disconnect the air hose from the exhaust (1).
- Remove the 2 screws from the exhaust.

Tightening torque: 30 Nm.



- Remove the 2 screws that secure the muffler.

Tightening torque: 15 Nm.

- Remove the complete exhaust system.



	<p>Use a new exhaust gasket.</p>
--	---

- Remove the plastic cover.
- Remove the wheel spindle nut and washer (2).
- Remove the screw fastening the rear mudguard on right.
- Remove the rear wheel.

	<p>When re-installing, use a new nut.</p>
---	--

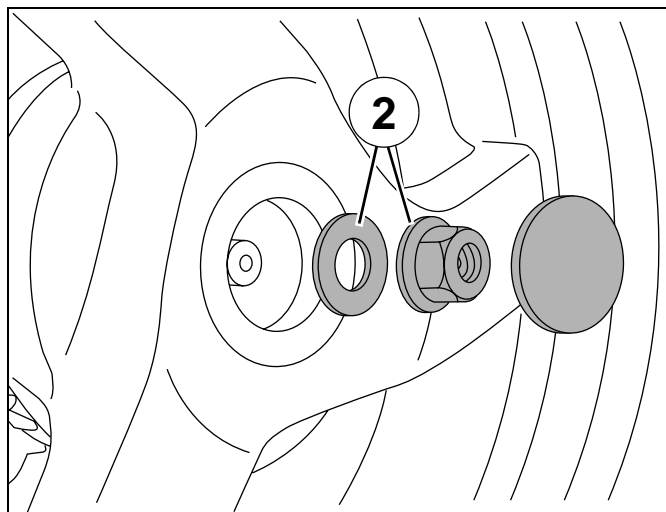

- Remove the brake linings (3).
- Remove the adjusting nut, the barrel (4) and the brake control cable (5).
- Remove the brake arm (6), the brake cam (7) and the spring.

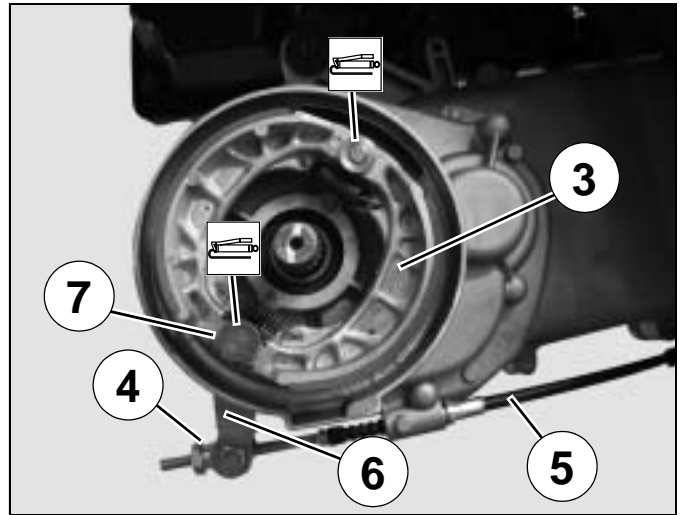

Reassembly.

	<p>Lubricate the brake cam spindle and fit it into the casing.</p>
--	---

- Fit the brake arm (6) by aligning it with the brake cam axis (7).

Tightening torque: 6 Nm.

- Slightly lubricate the brake cam and pin.
- Install the brake linings.
- Install the spring (8).
- Install the brake control cable, the barrel and the adjusting nut (4).
- Install the wheel.

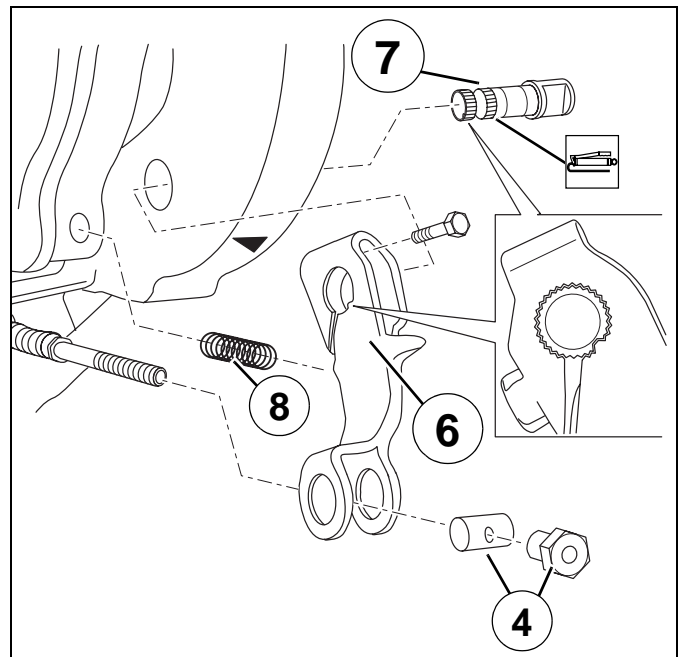

Tightening torque: 120 Nm.

- Measure the free travel of the rear brake control lever.
- Adjust the lever free travel using the adjusting nut.

B. Brake control free travel: 10 to 20 mm.

- Refit the other items in the reverse order to disassembly.

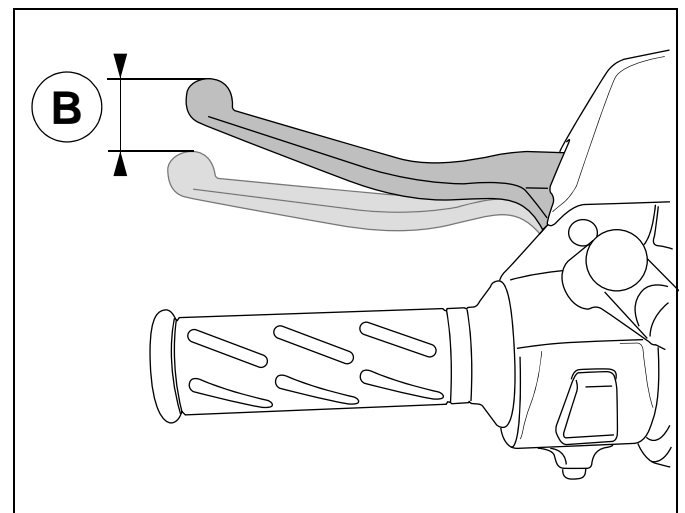

■ **Draining the front fork**

- Suspend or immobilize the machine securely.
- Remove the caliper 2 fixing bolts.
- Remove the front shield panel. See: Procedure 5. page 20.

- Unscrew and remove the 2 upper screws (1) from the fork Tee.
- Unscrew the 2 lower screws (2) from the fork Tee.
- Remove the fork stanchions.

- Remove the fork tube cap (3).
- Remove the spring (4).

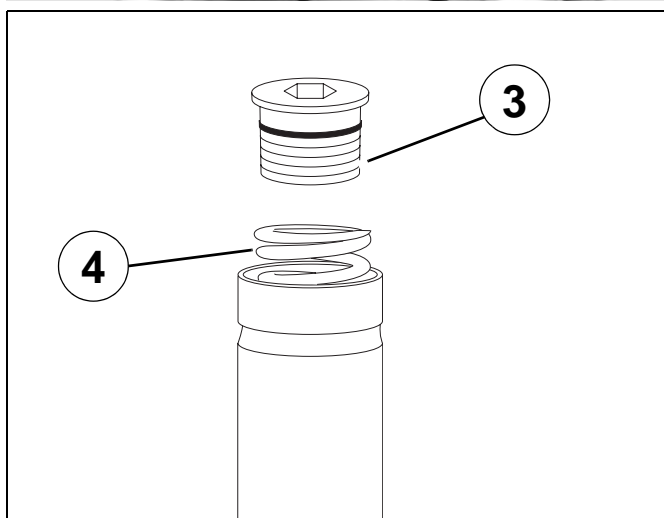
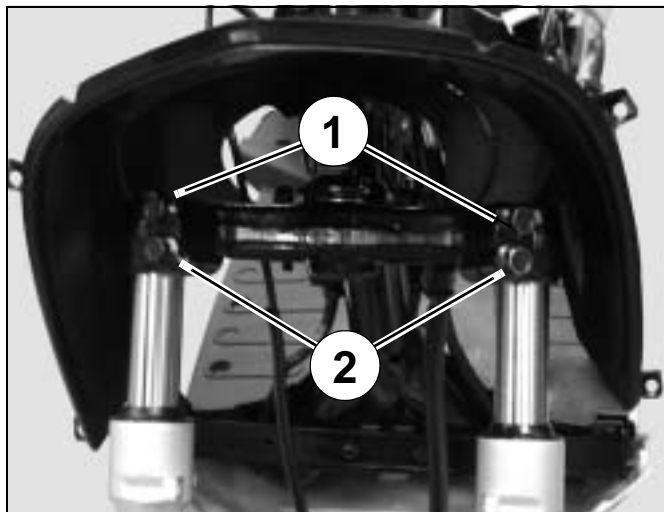

Turn the fork tube upside down to drain the oil into a recipient.

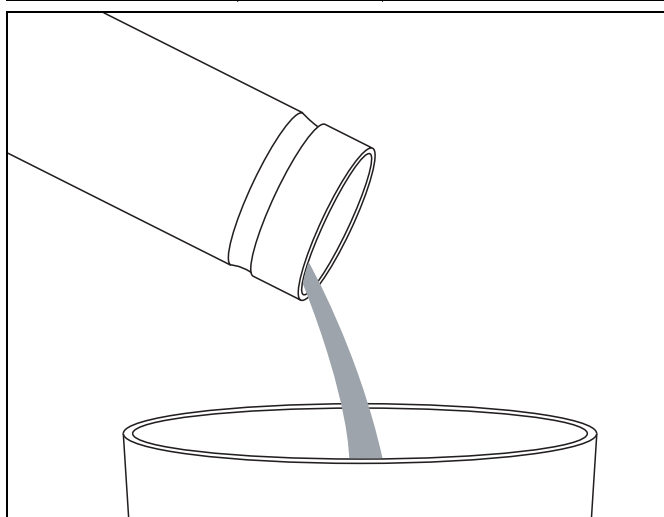

- Pour new oil into the fork tube. Type: SAE10W.

Quantity: 0.085 l.

- Install the spring.
- Fit and screw the cap home.

Tightening torque: 18-20 Nm.

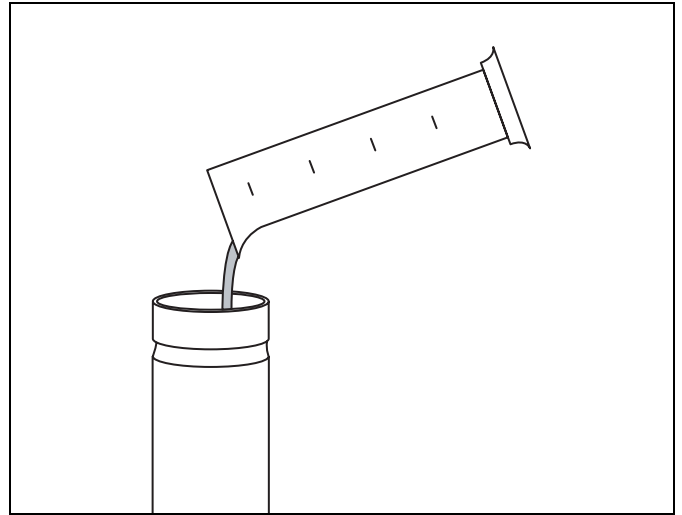

- Insert the fork stanchions into the fork tee.
- Fit and tighten the 4 clamping bolts.

Tightening torque: 20-25 Nm.

- Fit the front shield panel.

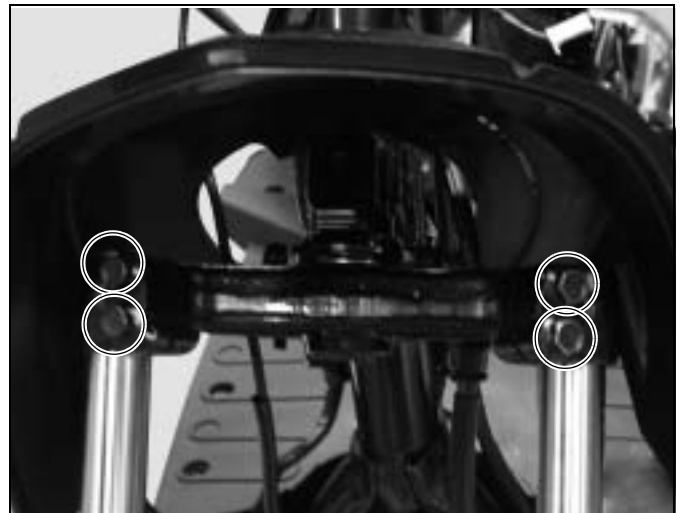

- Fit the front mudguard.
- Fit the speedometer drive gear assembly to the wheel drive pins.
- Fit the wheel, matching the speedometer drive gear assembly to the pin (A) on the fork stanchion.
- Fit the wheel spindle and tighten.

Tightening torque: 65 Nm.

N

When re-installing, use a new nut.

- Refit the other items in the reverse order to disassembly.

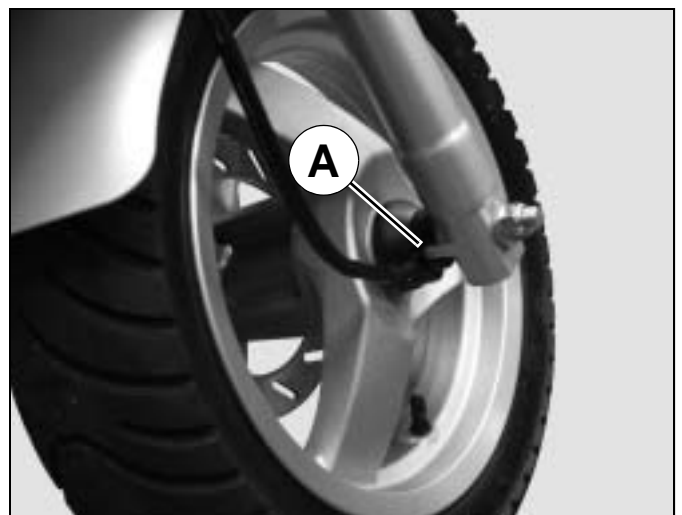

MISCELLANEOUS OPERATIONS

■ **Removal of the fork**

■ **Replacing the bearings of the steering system**

- Remove the rear shield panel. See: Procedure 4 page 19.
- Remove the handlebars from the fork tube. (1 screw and 1 nut) (1).

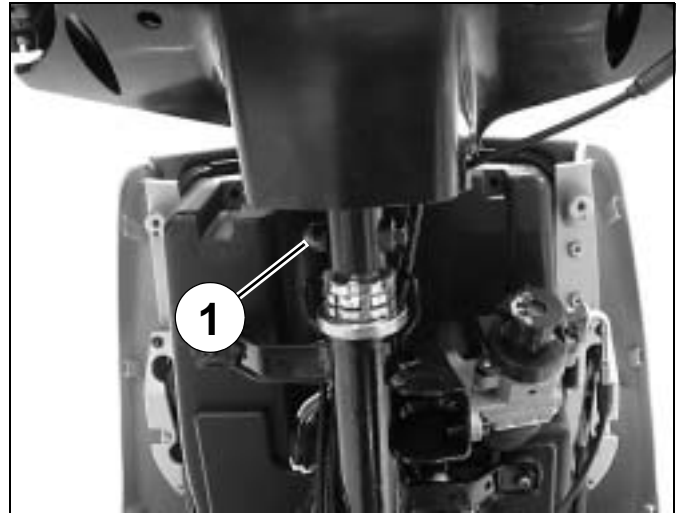

	<p>When re-installing, use a new nut.</p>
---	--

Tightening torque: 25 Nm.

- Suspend or immobilize the machine securely.
- Remove the front mudguard.
- Remove the front brake caliper from the fork tube.

Tightening torque: 25 Nm.

- Remove the front wheel.

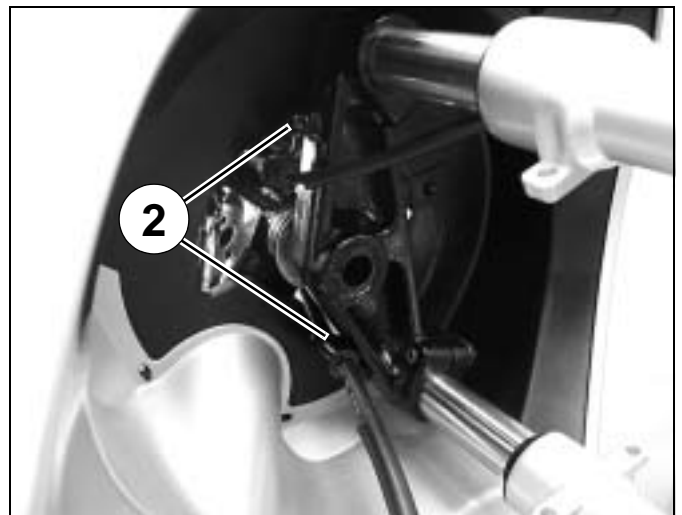

	<p>When re-installing, use a new nut.</p>
---	--

Tightening torque: 65 Nm.

- Remove the brake control cable grommet and the speed sensor located under the fork triple clamp (2) (2 screw).
- Using tool P/N 757860 remove the steering locknut.
- Remove:
 - The lock washer.
 - The nut.
 - the rubber washer.
 - The nut.
 - The dust cover.
 - The upper cone.
- Remove the fork.
- Remove the caged ball bearings.

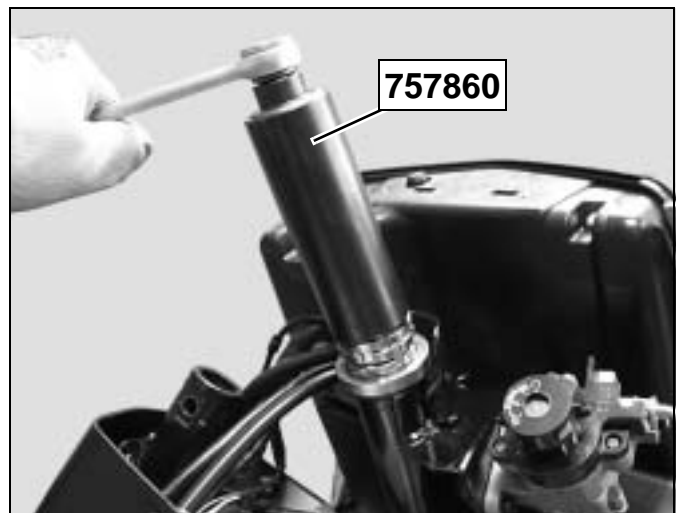

- Using a drift, remove the steering head cups.



- Using a chisel, pry the steering head cup off by pressing the tool behind the dust cover.



Reassembly.

- Install the following new parts:
 - The dust cover (1).
 - The fork cone (2).

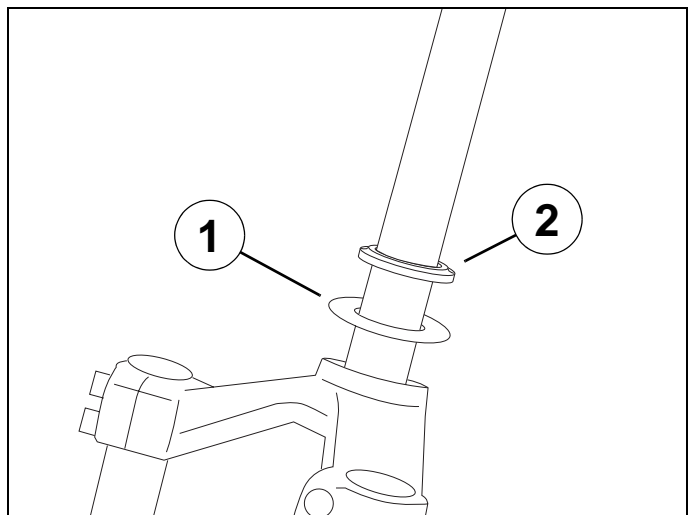

■ **Steering system tightening method**

- Using push tool P/N 753726, fit a new upper cup into the steering tube.
- Using push tool P/N 757990, fit a lower cup into the steering tube.



- Grease the cup bearing races.
- Install new caged ball bearings (3).
- Fit the fork into the steering column.

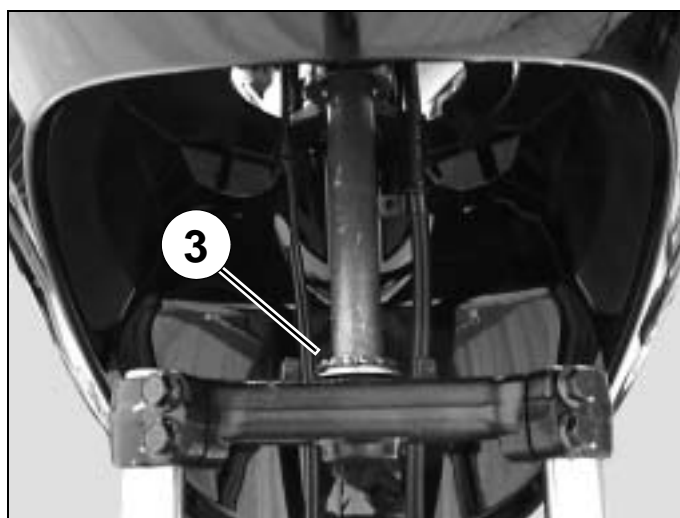

- Install the upper cone (4).
- Install the dust cover (5).
- Fit and tighten the nut (6).

Tightening torque: 40 Nm.

- Loosen and re-tighten the nut.

Tightening torque: 23 Nm.

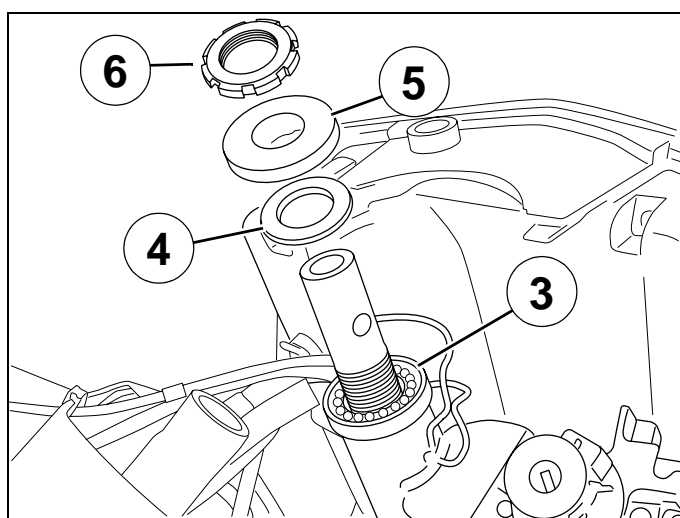

- Install the rubber washer (4).
- Fit and finger tighten the nut (5) so that its notches are aligned with those of the nut.
- Fit the lock washer (6) in the notches of the 2 nuts.

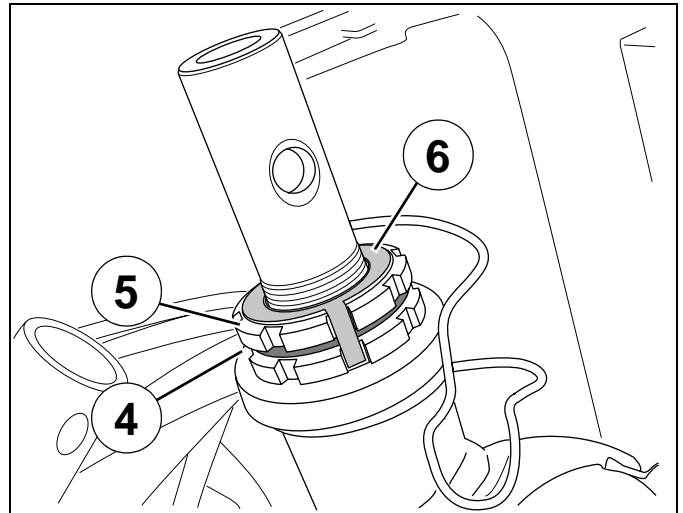

- Install the steering head locknut and tighten it (7).

Tightening torque: 70 Nm.

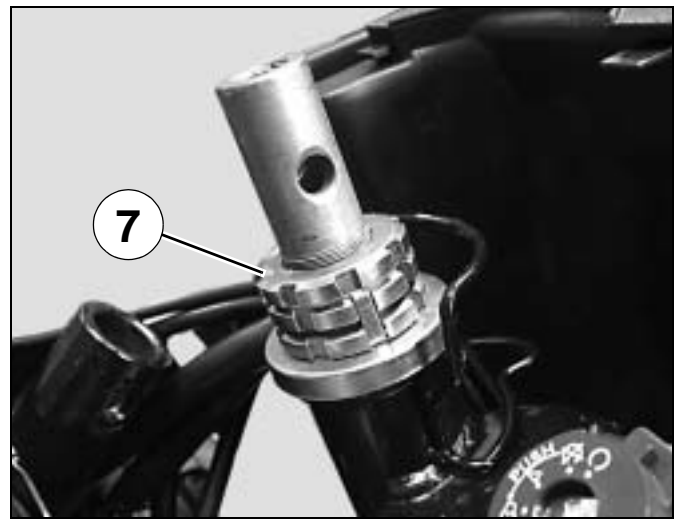

■ Changing the front fork seals

- Suspend or immobilize the machine securely.
- Remove the caliper 2 fixing bolts.
- Remove the front shield panel. See: Procedure 5. page 21.
- Unscrew and remove the 2 upper screws (1) from the fork Tee.
- Unscrew the 2 lower screws (2) from the fork Tee.
- Remove the fork stanchions.

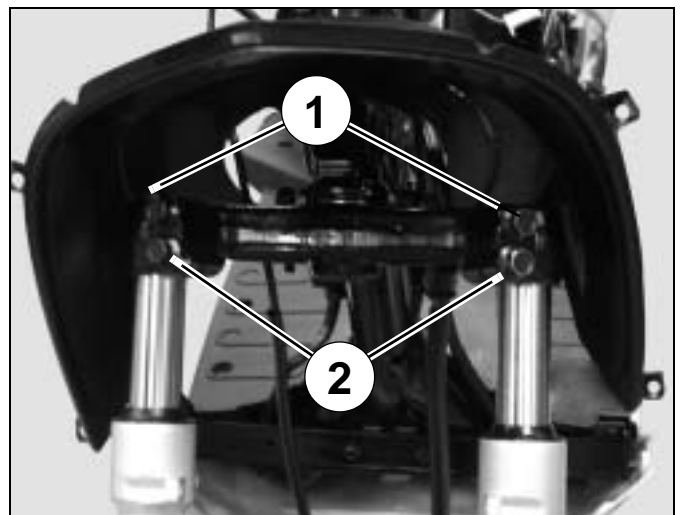

Removal of the fork tubes

- Remove the fork tube cap (1).
- Remove the spring (2).

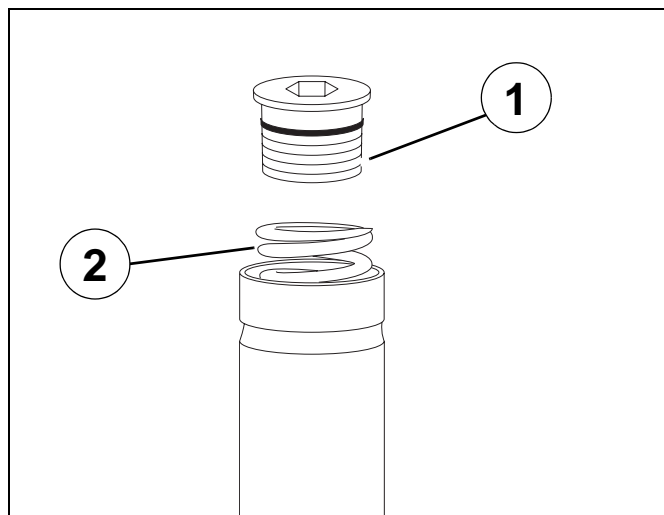

Turn the fork tube upside down to drain the oil into a recipient.

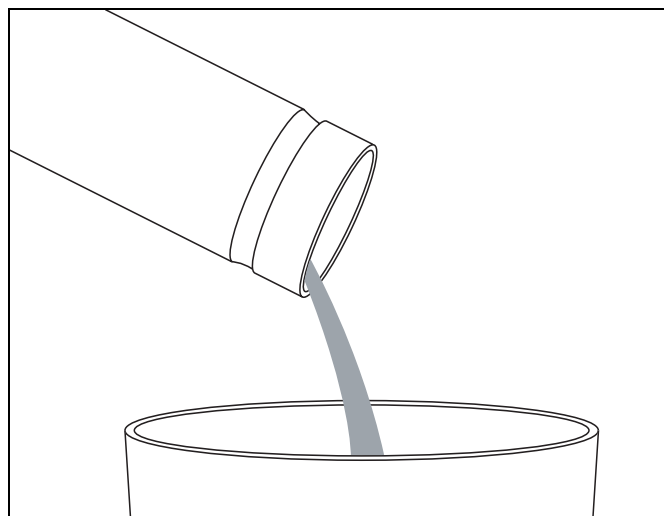

- Remove the stanchion assembly screw (12) and its seal.
- If necessary use a mallet to dislodge the screws.
- Separate the fork's tube (9) from the cover (11).
- Remove the compression stop cone (10).
- Remove the calibrated hydraulic tube (3).
- Remove the expansion stop spring (4).

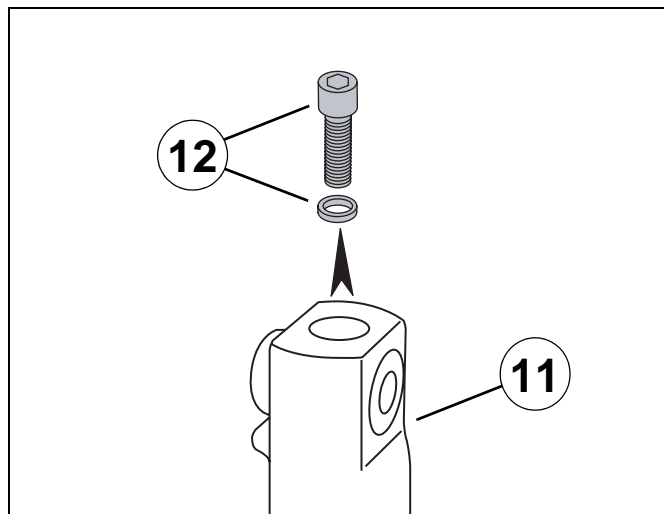

- Remove the dust cover (5).
- Remove the retaining clip (6).
- Remove the seal (7).
- Remove the washer (8).

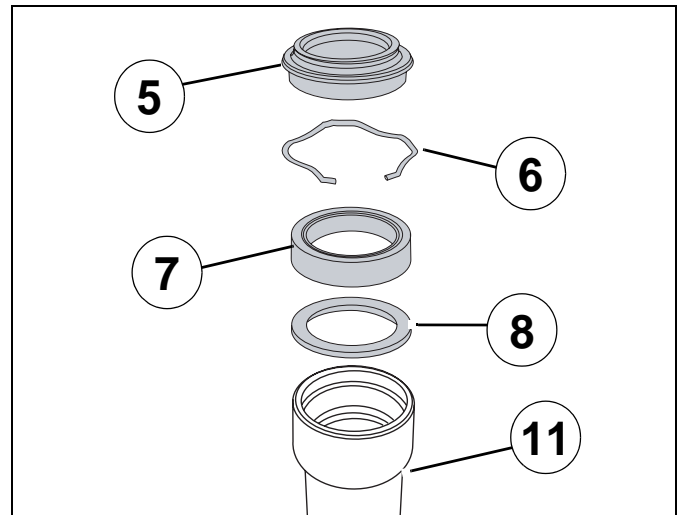

■ The fork and its components

1. Fork tube cap.
2. Spring.
3. Calibrated hydraulic tube.
4. Expansion stop spring.
5. Dust cover.
6. Retaining clip.
7. Tightness seal.
8. Plain washer.
9. Fork tube.
10. End of compression cone.
11. Hollow shaft.
12. Stanchion assembly screw.

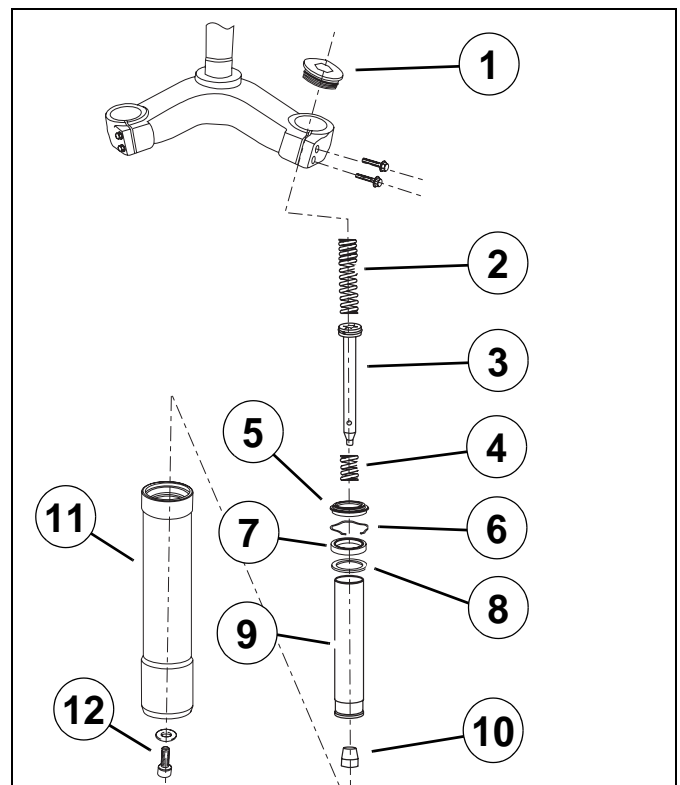

Pre-assembly checks

- Clean all the parts with a degreasing agent:
 - Biosane type ref. 754748.
 - Or use an ultrasonic cleaning tank.
- Check the condition of the fork tube, there shall be no corrosion or impact marks, and the tube shall be perfectly straight and clean.

Reassembly

On the fork tube

- Install the expansion stop spring (4).
- Install the calibrated hydraulic tube (3).
- Install the compression stop cone (10) on the calibrated hydraulic tube.

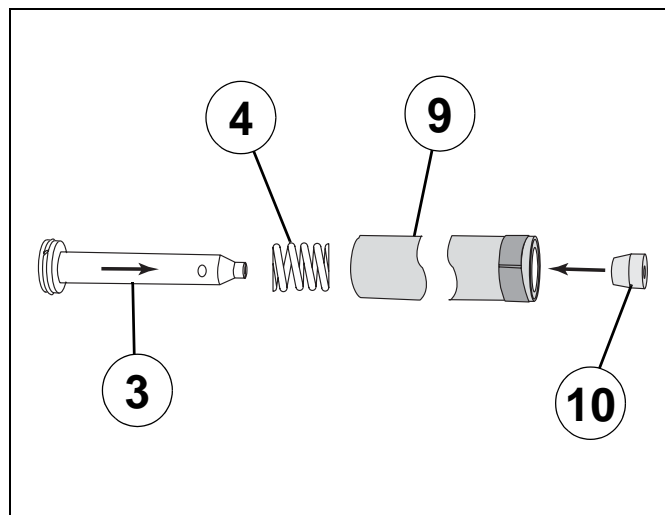

- Fit the fork sleeve (11) to the slightly oiled fork tube (9).
- Install the stanchion assembly screw and its seal (11).

Tightening torque: 25 Nm.

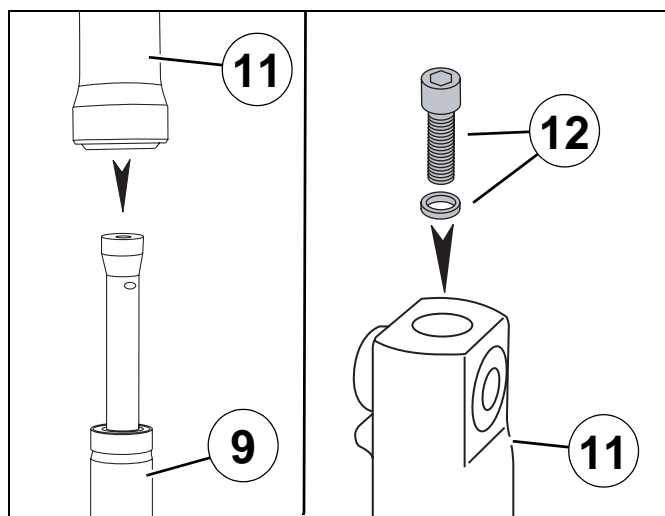

- Fit the plain washer.
- Install the new lightly lubricated seal (7).
- Using the marolotest lip seal insertion kit tool, push the seal (7) under the groove in the retaining ring.

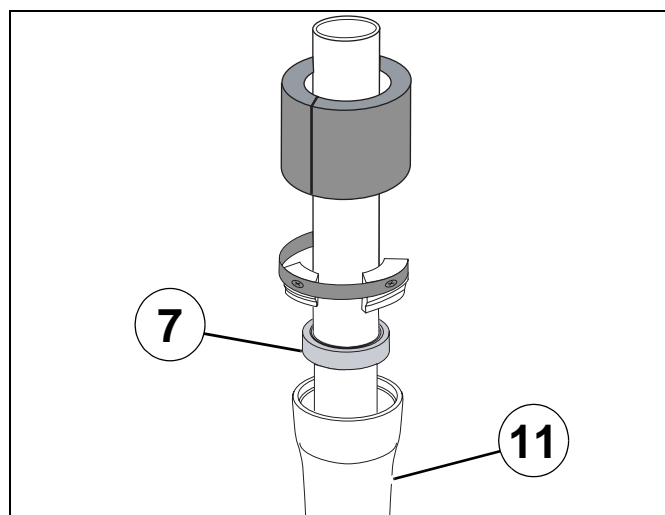

- Install the retaining ring (6).
- Fit a new, lightly greased dust cover (5).

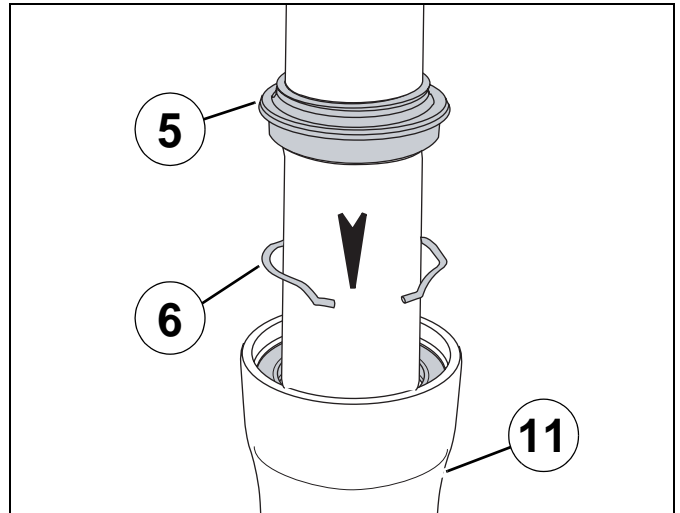

- Pour 0.085 l SAE10W hydraulic oil into the fork tube.
- Install the spring (2).
- Fit and screw the cap home (1).

Tightening torque: 18-20 Nm.

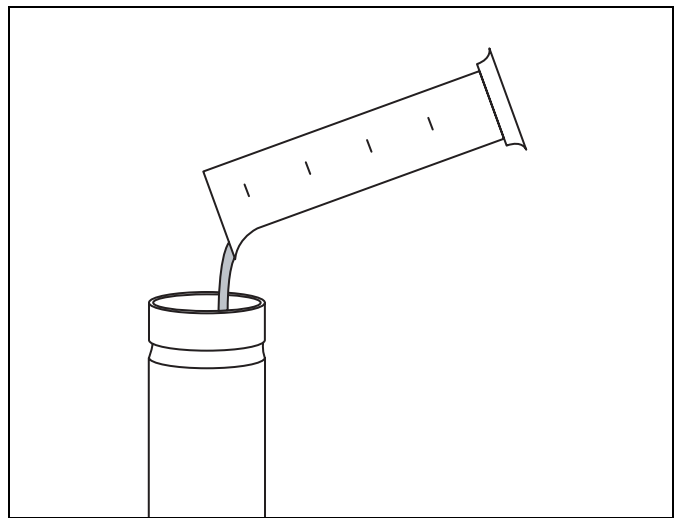

- Fit the fork tubes into the fork triple clamps.
- Fit and tighten the (4) clamping bolts.

Tightening torque: 20-25 Nm.

- Re-install all the fork equipment.
- Refit the fairings in reverse order to removal.

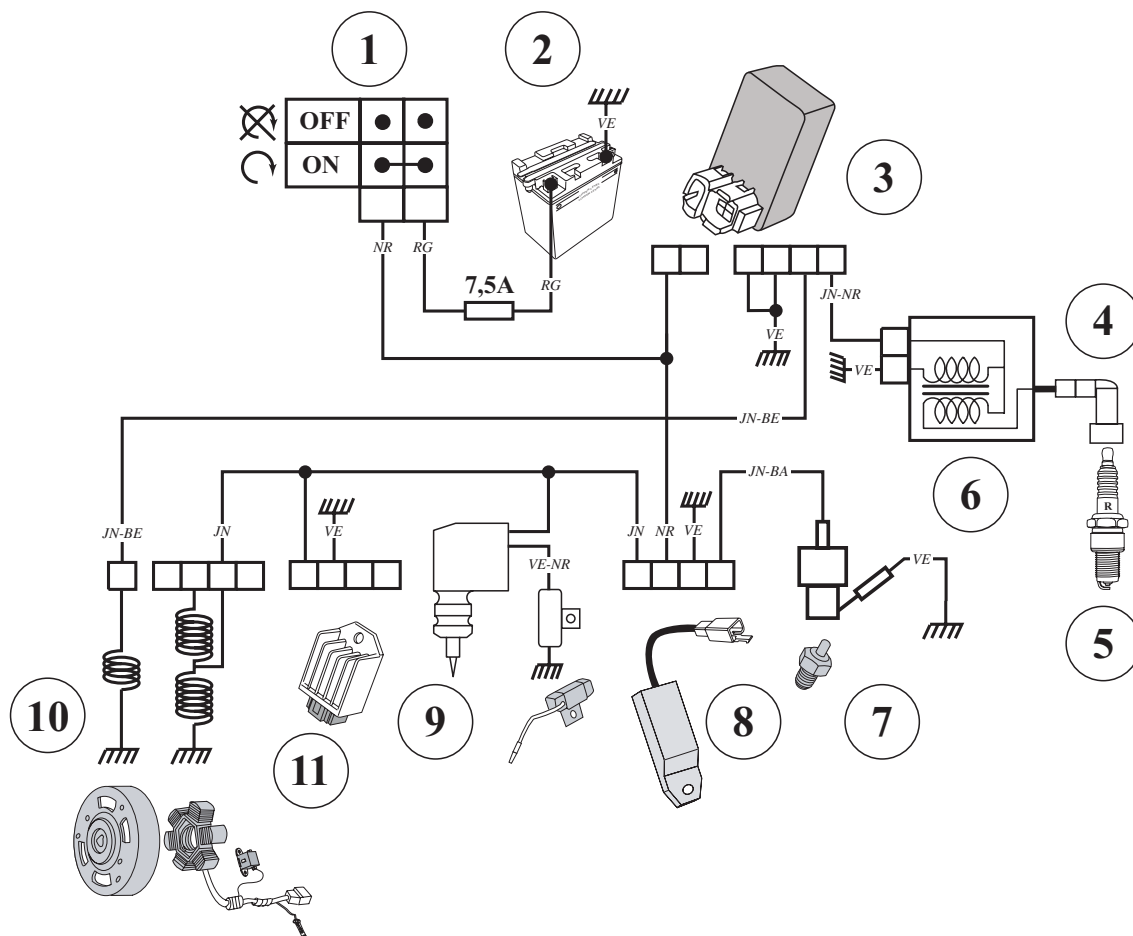

ELECTRICITY**■ Ignition principle schematic/Carburetor heater**

- | | |
|-----------------------|------------------------------|
| 1. Ignition switch. | 7. Carburetor heater. |
| 2. Battery. | 8. Temperature control unit. |
| 3. CDI unit. | 9. Automatic starter. |
| 4. Spark plug socket. | 10. Magneto flywheel. |
| 5. Spark plug. | 11. Regulator. |
| 6. HT coil. | |

■ Temperature control unit/Regulator/Starter motor relay/Ignition unit

- Remove the rear cover assembly. See: Procedure 2 page 17.
- Removal:
 - The temperature control unit (1).
 - Regulator (2).
 - The starter motor relay (3).
 - The ignition module (4).
 - The starter resistor (5).

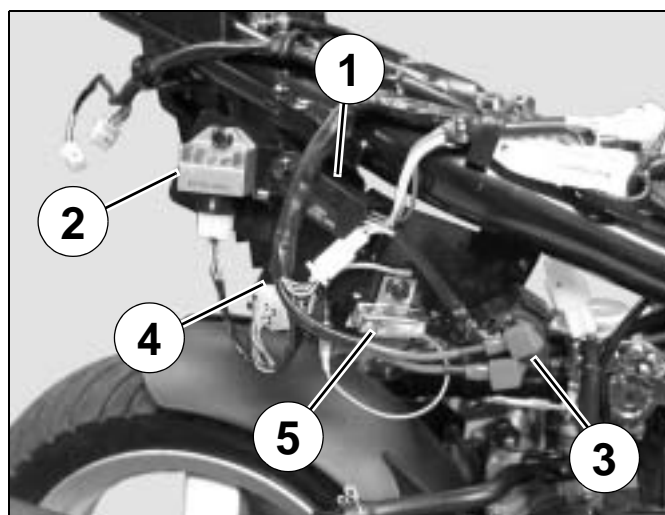

■ Checking the carburettor heating circuit

Power supply range of the carburettor heating resistor: between $10^{\pm 2}$ and $20^{\pm 2}$ °C.

- **Disconnect the temperature control unit and take the measurements on the harness side.**
 - Between the green wire and the ground: 0Ω .
 - Between the white/yellow wire and the ground (Resistor warming carburator): $8.5 \Omega^{\pm 20\%}$.
 - Between the black wire and the ground, ignition on: 12 V (Battery voltage).
 - Between the yellow wire and the ground, engine running: 13.5 V (Regulated alternating current).
- If the values are correct, replace the temperature control unit.
- If the values are incorrect, check:
 - The harness.
 - The ignition switch.
 - The carburettor heating resistor: $8.5 \Omega^{\pm 20\%}$.

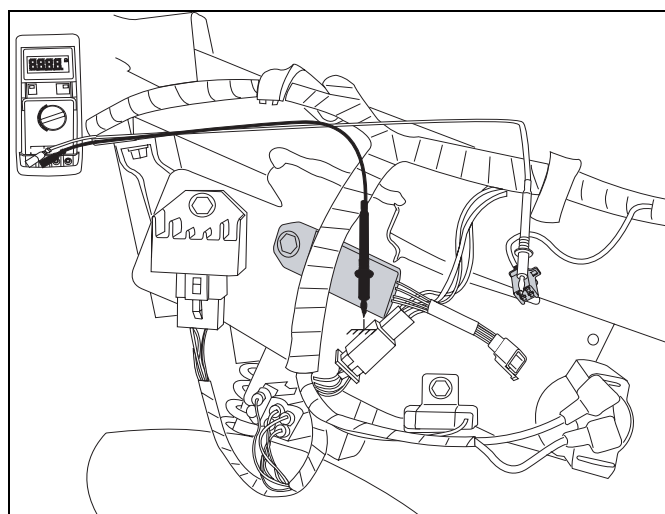

■ Checking the ignition system

Disconnect the ignition unit and take the measurements on the harness side.

- Between the green wire and the ground: 0Ω .
- Between the yellow/black wire and the ground (Primary high voltage coil): $0.2 \Omega \pm 20\%$.
- Between the yellow/blue wire and the ground (Ignition sensor) : $115 \Omega \pm 20\%$.
- Between the black wire and the ground, ignition on: 12 V (Battery voltage).

- If the values are correct, replace the ignition module.
- If the values are incorrect, check:
 - The ignition switch.
 - The harness.
 - The high voltage coil.

Primary: $0.2 \Omega \pm 20\%$.

Secondary: $5 \text{ k}\Omega \pm 20\%$.

- The suppressor: $5 \text{ k}\Omega \pm 20\%$.
- The ignition sensor:

Between the yellow/blue wire and the ground: $115 \Omega \pm 20\%$.

■ Removal of the high tension coil

- Remove the rear storage compartment.
See: Procedure 1 page 17.
- Disconnect the suppressor (6).
- Disconnect and remove the high voltage coil.

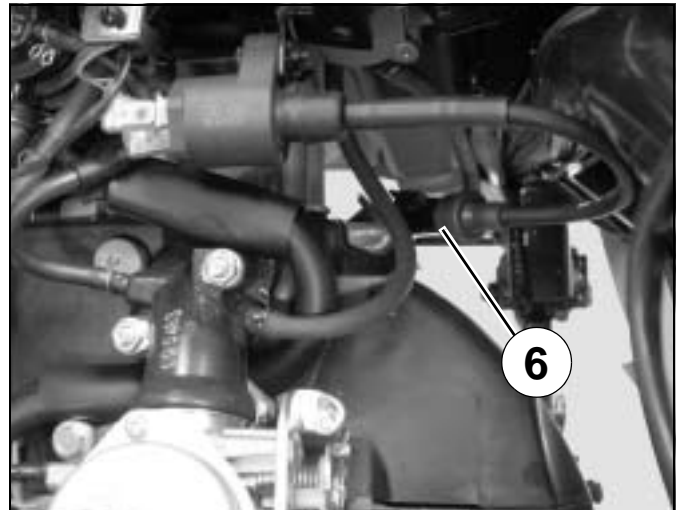
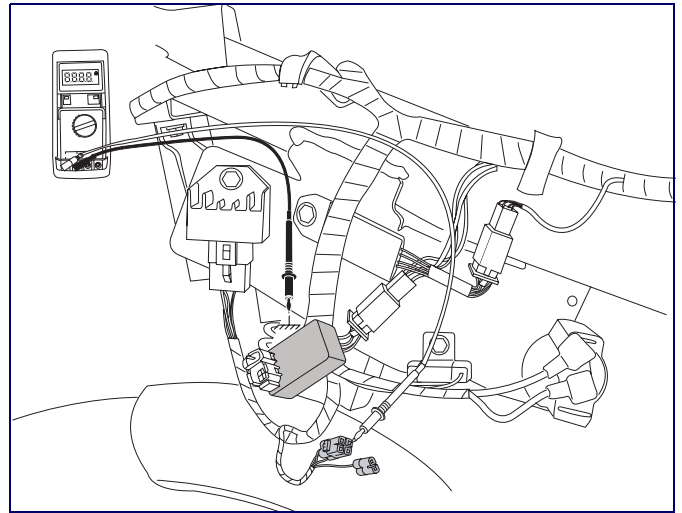

FUEL SYSTEM

■ Removal of the fuel pump

- Remove the rear storage compartment.
See: Procedure 1 page 17.
- Remove the central cover panel (5 screw).
- Remove the tank filler ring.
- Remove the 2 screws that secure the fuel pump.
- Clamp the end of the fuel inlet pipe using a clip ref. 755996 (1).
- Disconnect the fuel inlet pipe (1).
- Disconnect the fuel supply hose from the carburettor (2).
- Disconnect the vacuum hose (3).
- Remove the fuel pump.

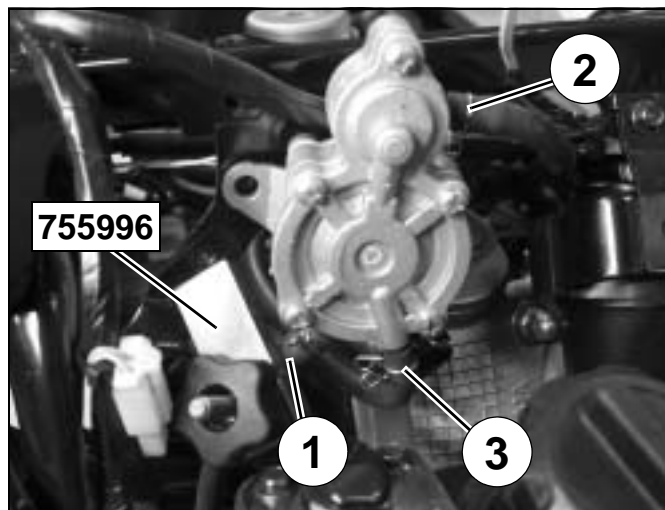

■ Removal of the fuel gauge

- Remove the rear storage compartment.
See: Procedure 1 page 17.
- Remove the central cover panel (5 screw).
- Remove the tank filler ring.
- Disconnect the fuel gauge (1).
- Remove the fuel gauge (4 screw).
- Remove the rubber gasket.



When re-installing, use a new gasket.

Check:

- Full fuel tank: $10 \Omega \pm 20\%$.
- Empty fuel tank: $95 \Omega \pm 20\%$.

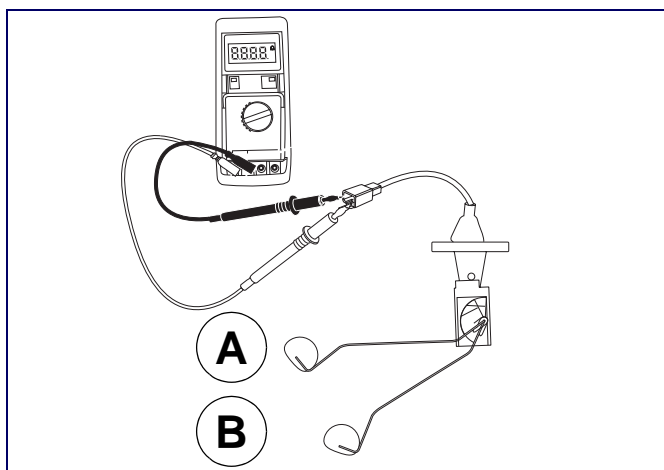

■ Removal of the fuel tank

- Remove the footboard. See: Procedure 6 page 21.

- Remove the footboard supports (1) (4 screw).

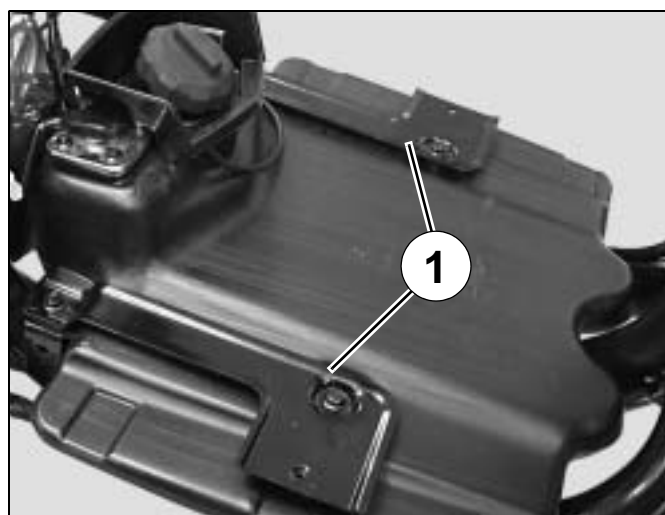

- Clamp the end of the fuel inlet pipe using a clip ref. 755996 (1).

- Disconnect the fuel supply hose.

- Disconnect the fuel gauge.

- Remove the fuel tank.

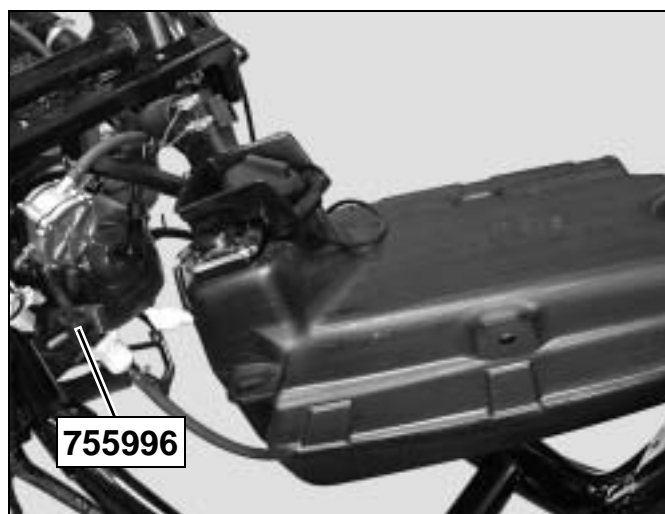

■ Removal of the carburettor

- Remove the rear storage compartment. See: Procedure 1 page 17.
- Disconnect:
 - The throttle control (1).
 - The fuel inlet pipe (2).
- Disconnect the electric choke (3).
- Disconnect the carburettor heater (4).
- Remove the intake silencer (1 collar and 2 screws).
- Loosen the collar.
- Remove the carburettor.

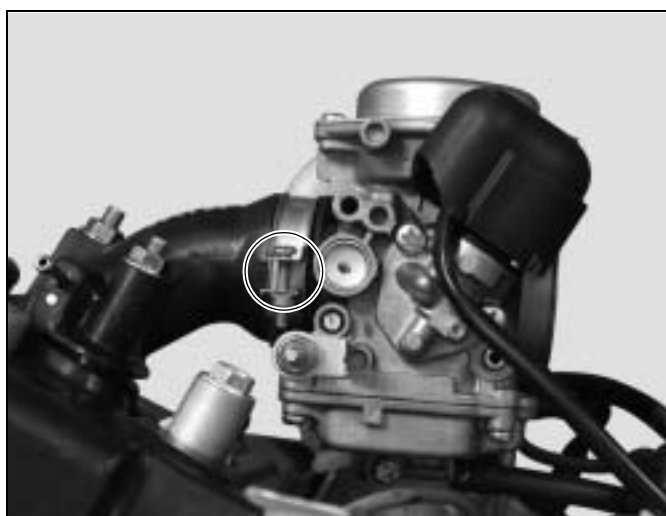
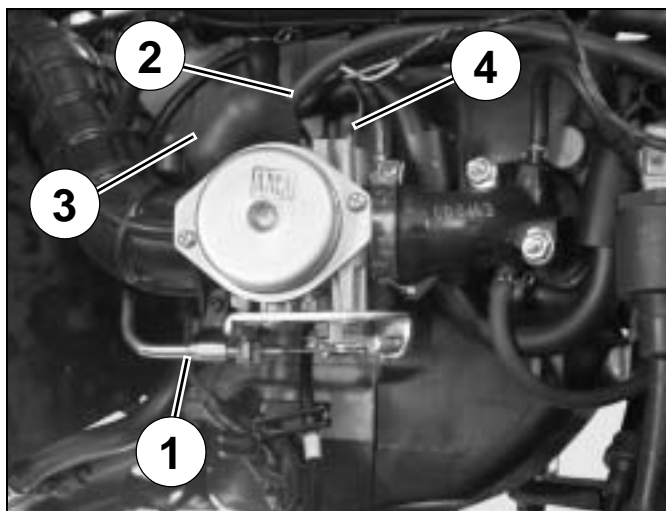

Removal of the choke

- Remove the choke cap.
- Remove the screw and the holder plate.
- Locate the position of the choke (1) and then remove it.

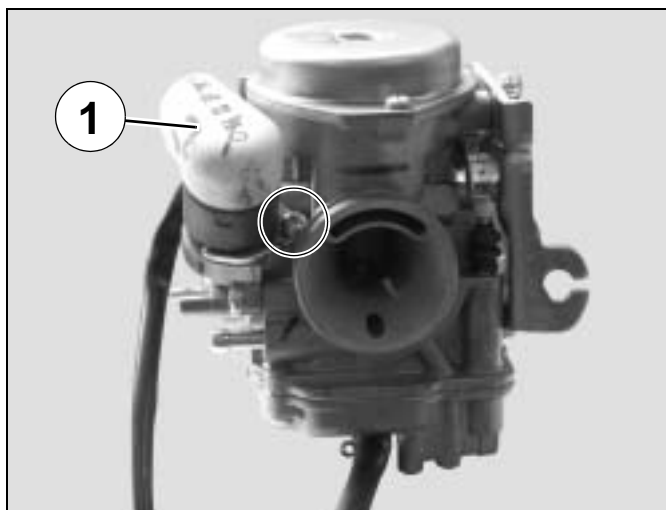

Removal of the starter holder and its gasket

- Remove the 2 screws securing the choke.
- Remove the O ring.

	<p>Check the condition of the O-ring.</p>
---	--



Removal of the throttle valve

- Remove the 2 screws that secure the chamber cap.
- Remove the chamber cap.
- Remove the spring.
- Remove the needle, valve and membrane assembly.

	<p>Check that the membrane is in good condition.</p>
---	---

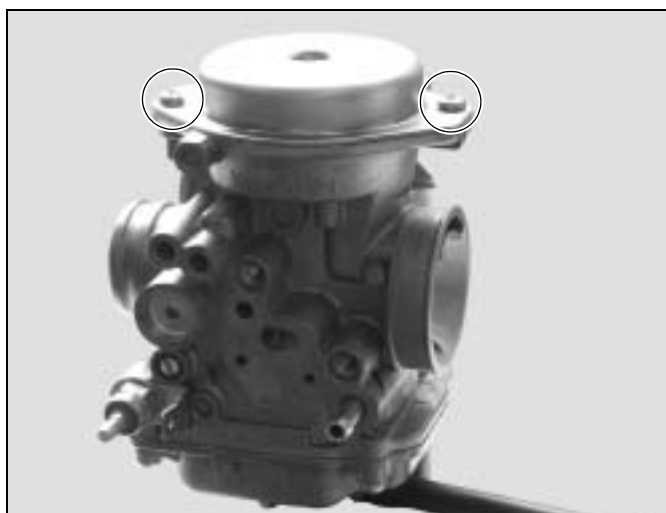

- Remove the needle stop (1).
- Remove the spring (2).
- Remove the needle (3).

	<p>The height of the needle is factory set and cannot be modified.</p>
---	---

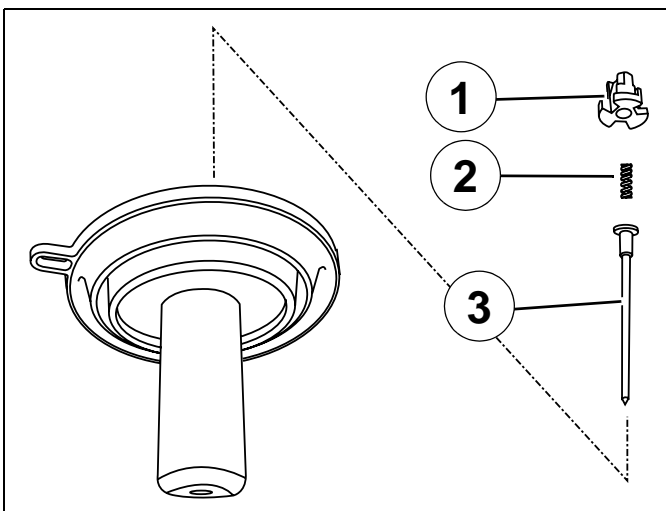

Removal of the float, needle valve and jets

- Remove the 4 screws that secure the float chamber (1).
- Remove the float chamber and its O-ring.



Check the condition of the float chamber O-ring.

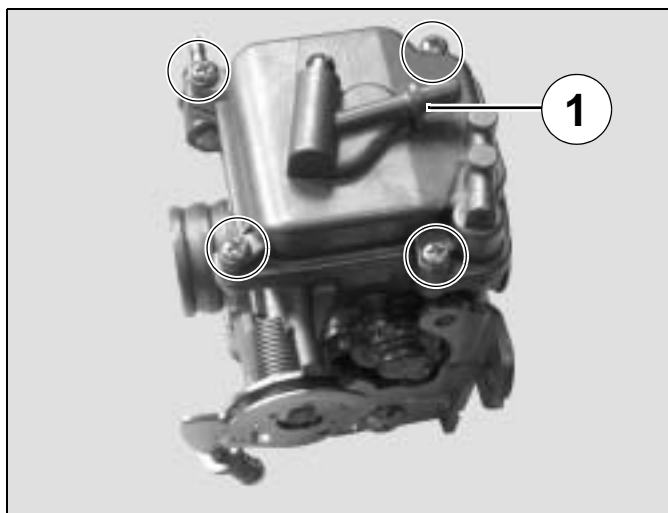

- Loosen the float pin clamping screw (2).
- Remove the float (3), its pin (4) and the needle valve (5).

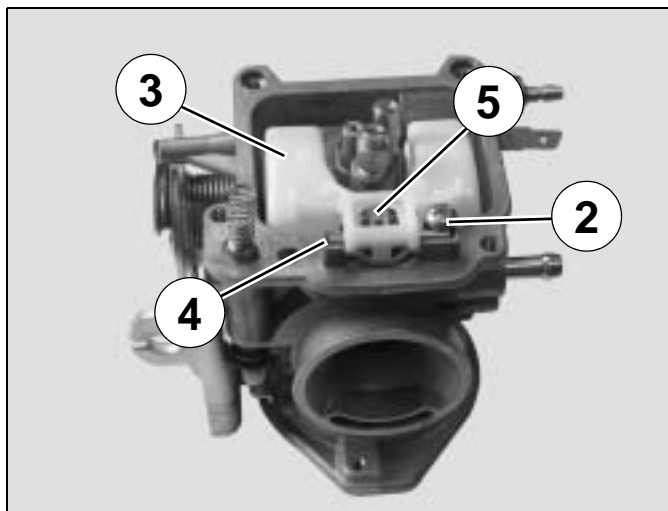

- Remove the idle jet (6).
- Remove the main jet (7).
- Remove the needle well (8).

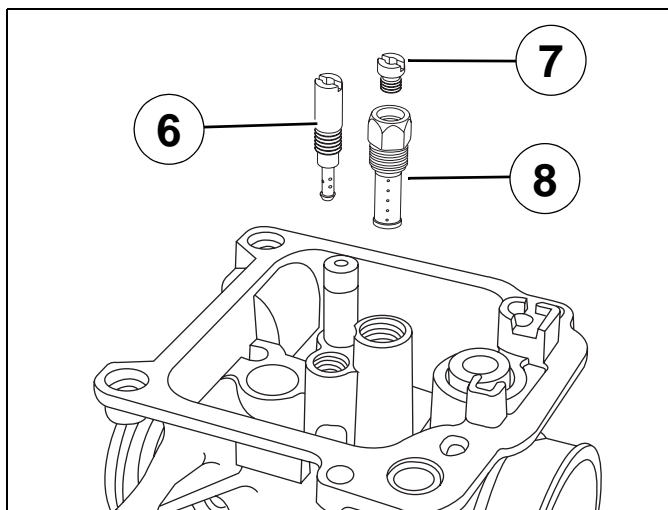

✓	Check the condition of the needle valve and the needle valve seat (A).
---	---

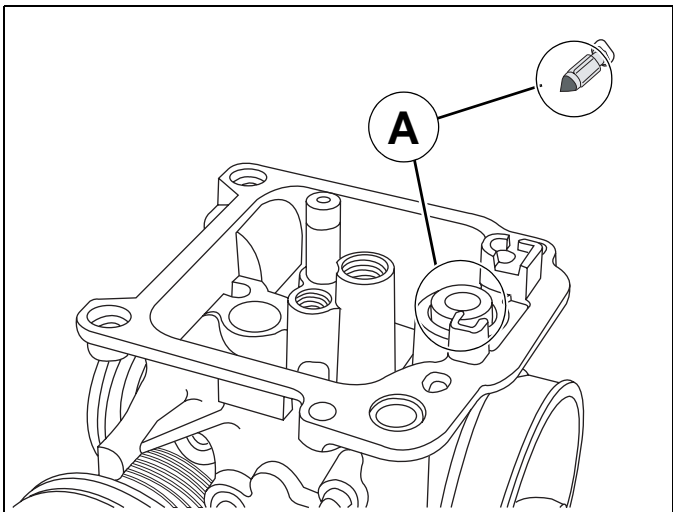

Removal of the mixture screw

- Turn clockwise the mixture control screw (1) while counting the number of turns until it is screwed home.

✓	When re-fitting, this operation allows you to put it back to its initial adjustment position.
---	--

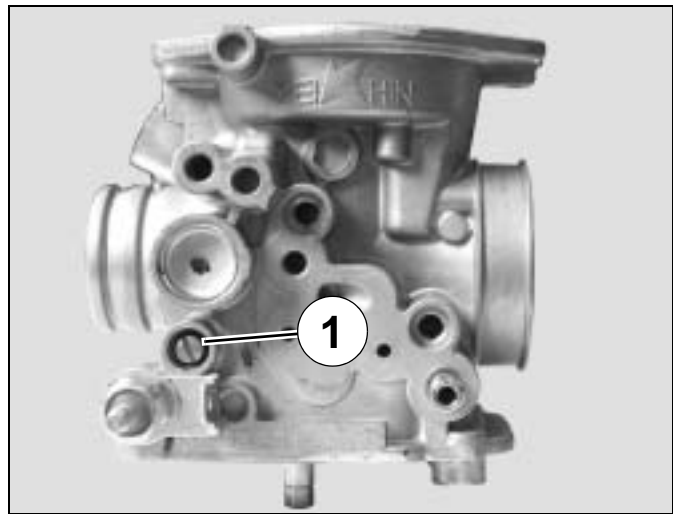

Removal of the pick-up pump

- Remove the 2 screws from the sheathing holder plate.
- Remove the bushing (1) and the protective rubber (2).

✓	Check the condition of the bushing and the rubber protection.
---	--

- Remove the piston (3).

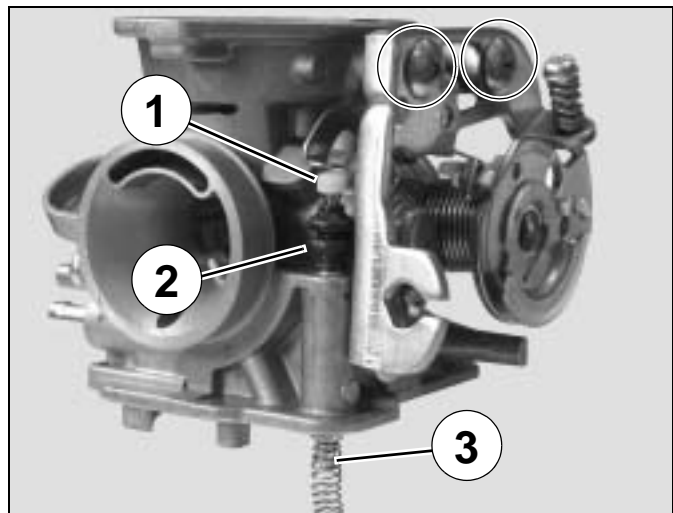

Removal of the pick-up pump suction valve

- Remove the jet.
- Remove the spring.
- Remove the ball.



Removal of the deceleration enrichment device

- Remove the 2 bolts that secure the cover.
- Remove the cover.
- Remove the spring.
- Remove the membrane.
- Remove the O ring.

	<p>Check that the membrane is in good condition.</p> <p>Check the condition of the O-ring.</p>
---	--

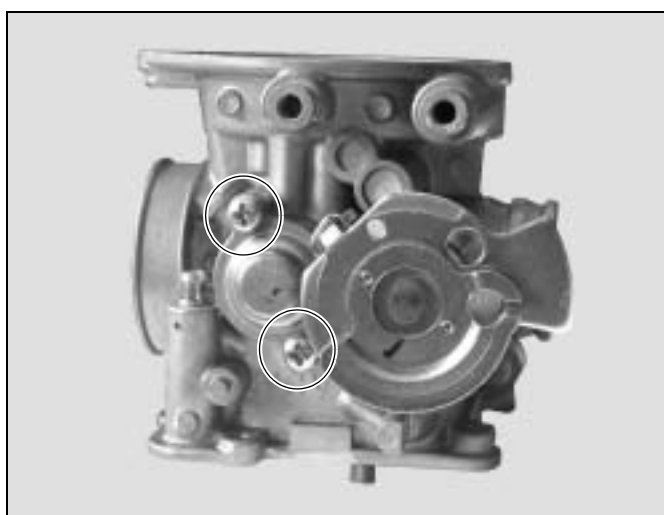

Remove the carburetor warming resistor

- Remove the carburetor warming resistor (1).
- Remove the heater earthing connection (2).

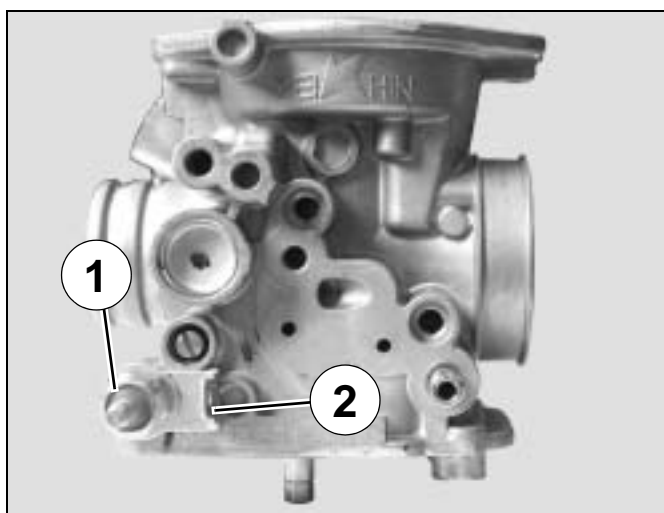

- Clean the carburettor body with Biosane cleanser ref. 754748 or use an ultrasonic cleaning tank.
- Blow into every jet and duct of the carburettor body with compressed air.



Do not use any metal tool which can damage the ducts of these items.

- Re-install all the other components and, if necessary, when starting the engine, readjust according to the values indicated on the technical data card.

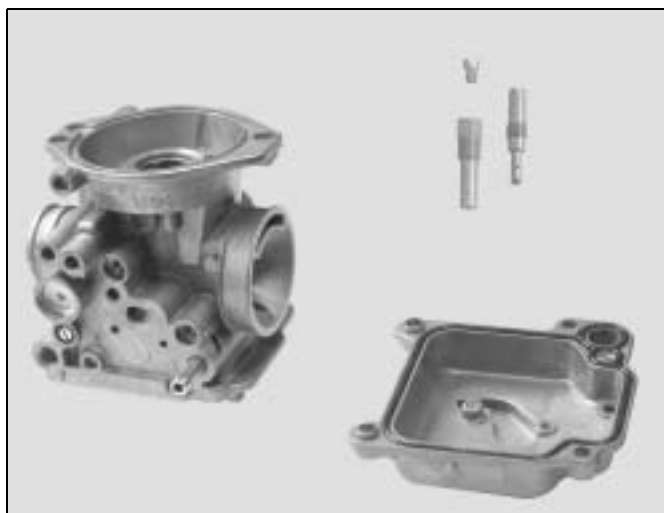

■ The carburettor and its components

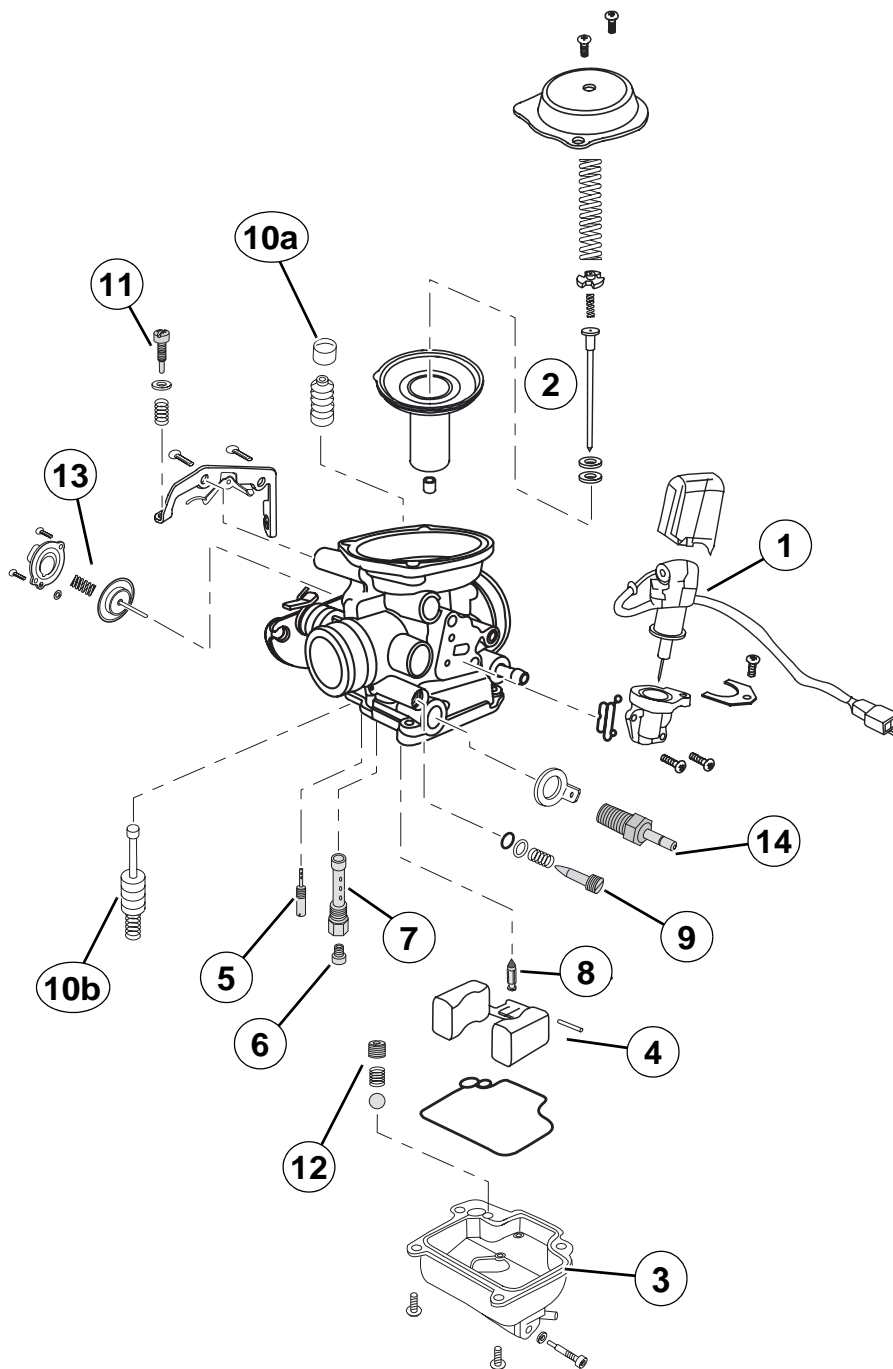

- | | |
|------------------|-------------------------------------|
| 1. Choke. | 9. Mixture screw. |
| 2. Piston. | 10. Pick-up pump (10a and 10b). |
| 3. Sump. | 11. Idle screw. |
| 4. Float. | 12. Pick-up pump suction valve. |
| 5. Idle jet. | 13. Deceleration enrichment device. |
| 6. Main jet. | 14. Carburetor heater. |
| 7. Needle well. | |
| 8. Needle valve. | |

POWER UNIT**■ Removal of the power unit**

Note: To remove the cylinder head, remove the power propulsion unit.

For removal of the cylinder head, cylinder and piston, see the workshop manual: Engine 50 cc 4 stroke 2 valves SYM: 900010.

- Disconnect the battery.
- Remove the rear cover assembly. See: Procedure 2 page 18.

- Disconnect:
 - The magneto (1).
 - The starter motor (2).
 - The choke (3).
 - The suppressor (4).

 - The carburettor heater (5).
- Disconnect:
 - The throttle control (6).
 - The fuel inlet pipe (7).
 - The vacuum pressure hose (8) (Pulsair).
 - The vacuum pressure hose (9) (Fuel pump).

 - The pulsair reed valve hose (10).
 - The rear brake control cable (11).

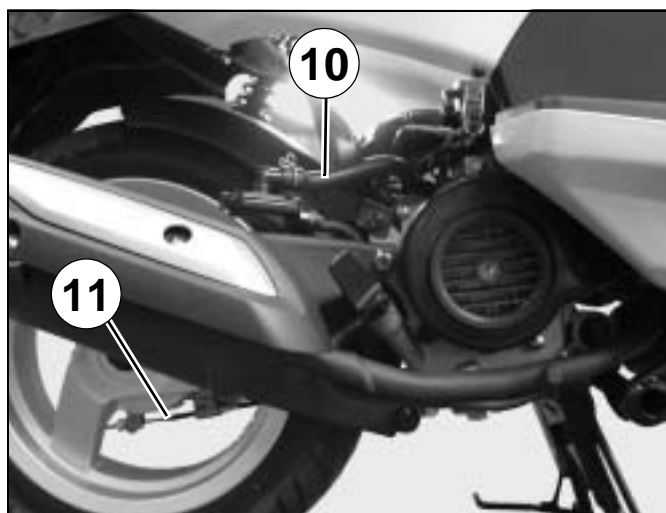
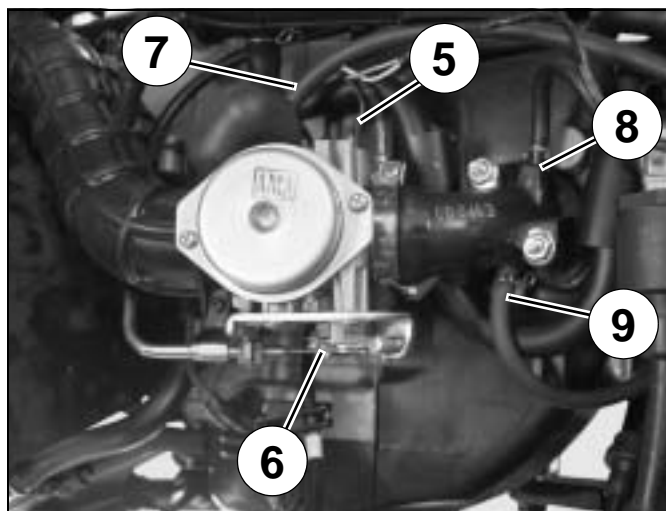
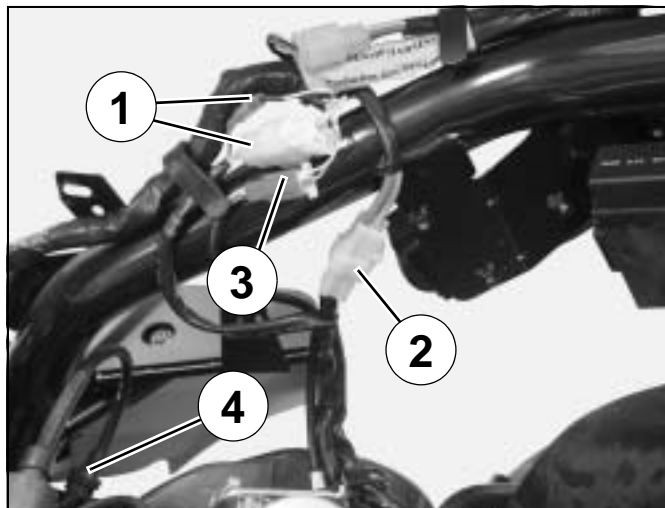

- Remove the linkrod-to-engine connecting pin (11).

Tightening torque: 60 Nm.



When re-installing, use a new nut.

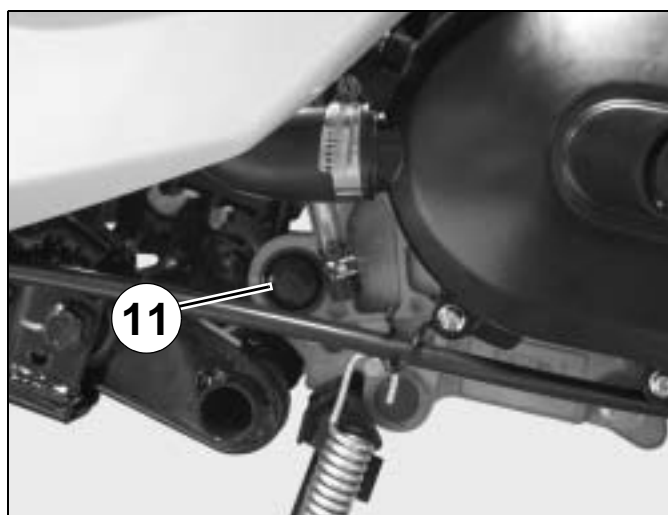

- Remove the shock absorber upper fixing bolt.

Tightening torque: 45 Nm.

- Lift the rear of the machine.
- Remove the power propulsion unit from the frame.

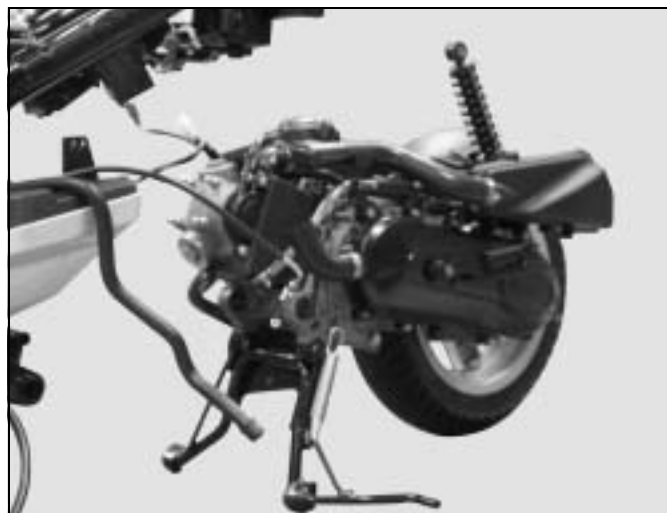





P/N. MA0013GB

Peugeot Motocycles is constantly improving its vehicles. It therefore reserves the right to remove, modify or add any reference mentioned in this manual.

DC/PS/APV Printed in the E.U. 12/2009 (non contractual pictures)

