



Sales division  
Technical network leadership

# WORKSHOP MANUAL



**V-Clic**



**TABLE OF CONTENTS**

<b>TABLE OF CONTENTS.....</b>	<b>1</b>
<b>CHARACTERISTICS.....</b>	<b>3</b>
Engine.....	3
Capacities.....	3
Chassis.....	4
Dimensions and weight.....	4
Tyres.....	4
Brakes.....	5
<b>SERVICE SCHEDULE AND COMMISSIONING.....</b>	<b>6</b>
Check.....	6
Change.....	6
Check and lubricate.....	6
Test machine.....	6
Battery preparation (Except battery without maintenance)*.....	6
Checks before handing over to the customer.....	7
<b>SPECIAL IMPORTANT POINTS.....</b>	<b>8</b>
Oil and fuel.....	8
Starting up after overhauling the engine.....	8
<b>TIGHTENING TORQUES.....</b>	<b>9</b>
Engine part.....	9
Body panels.....	9
Cycle part.....	10
Standard.....	10
<b>INSTRUMENT PANEL.....</b>	<b>11</b>
Analog functions (hands).....	11
<b>ELECTRICITY.....</b>	<b>12</b>
Fuses and energy distribution.....	12
Location of components.....	12
<b>BODY PANELS.....</b>	<b>13</b>
Location of body components.....	13
Body component sequence of disassembly.....	14
Removal of the storage compartment.....	15
Removal of the grab handle.....	15
Removal of the central cover panel.....	15
Removal of the lower side fairings.....	16
Removal of the side fairings.....	16
Removal of the footboard.....	16
Removal of the taillight.....	17

Removal of the splash guard. ....	17
Removal of the front top cover panel. ....	18
Removal of the front mudguard.....	19
Removal of the front shield panel.....	19
Removal of the rear shield panel. ....	20
Removal of the under body panel. ....	20
Removal of a headlight bulb.....	21
Removal of a taillight bulb. ....	21
Removal of a turnsignal light.....	22
<b>WORKING ON THE ENGINE WITHOUT REMOVING THE ENGINE .....</b>	<b>23</b>
Removal of the air filter foam. ....	23
Removal of the transmission filter. ....	23
Removal of the fuel filter.....	23
Removal of the pulsair filter.....	24
Removal of the pulsair reed valve. ....	24
Removal of the spark plug. ....	24
Removal of the carburettor.....	24
Installing the valve clearance. ....	25
Removal of the exhaust system. ....	25
Removal of the cylinder head.....	26
Removal of the cylinder / piston.....	26
<b>MISCELLANEOUS OPERATIONS .....</b>	<b>27</b>
Removal of the engine. ....	27
Removal of the battery. ....	27
Removal of the starter motor relay.....	27
Removal of the ignition module (CDI). ....	27
Removal of the fuse. ....	27
Removal of the regulator.....	28
Removal of the choke resistor.....	28
Removal of the horn.....	28
Removal of the blinker unit.....	28
Removal of the ignition switch.....	28
Removal of the high tension coil. ....	28
Removal of the kickstand contact switch.....	28
Removal of the fuel gauge. ....	29
Removal of the tank. ....	29
Removal of the front wheel. ....	29
Removal of the rear wheel. ....	30
Removal of the calliper.....	30
Removal of the brake pads. ....	30
Removal of the fork. ....	31
Replacing the bearings of the steering system.....	31
Steering system tightening method.....	32

**CHARACTERISTICS****■ Engine.****V-clic 50cc.**

Type.	4-stroke single-cylinder 2 valves per cylinder with chain driven overhead camshaft.
Cooling.	Air.
Bore x stroke.	39.0 x 41.4 mm.
Cubic capacity.	49.58 cm <sup>3</sup> .
Max. power output.	2.0 kW à 7000 tr/min.
Max. torque rating.	6000 tr/min.
Fuel supply.	Carburettor.
Lubrication.	Trochoidal pump.
Transmission.	By 2 variable pulleys and V-type belt.
Clutch.	Centrifugal automatic.
Spark plug.	NGK CR 7HSA.
Exhaust.	Catalytic.
Standards.	Euro 2.

**■ Capacities.**

Fuel tank.	6.3 l.
Engine oil.	0.8 l.
Relay box.	0.12 l.
Fork.	87cc by tube Esso Unavis 46 or Agip H Lift 46.

■ **Chassis.**

<b>Front suspension.</b>	Hydraulic telescopic fork.
<b>Travel.</b>	85 mm.
<b>Rear suspension.</b>	Combined spring and hydraulically-damped shock absorber.
<b>Travel.</b>	85 mm.

■ **Dimensions and weight.**

<b>Overall length.</b>	1660 mm.
<b>Width at handlebar.</b>	700 mm.
<b>Height (without rear-view mirrors).</b>	1070 mm.
<b>Wheelbase.</b>	1200 mm.
<b>Ground clearance.</b>	115 mm.
<b>Unladen weight.</b>	79 kg.

■ **Tyres.**

<b>Front wheel rim.</b>	10 inch aluminium alloy.
<b>Front tyre.</b>	3.50/10"
<b>Front tyre pressure.</b>	1.25 bars.
<b>Rear wheel rim.</b>	10 inch aluminium alloy.
<b>Rear tyre.</b>	3.50/10"
<b>Rear tyre pressure.</b>	1.75 bars.

■ Brakes

<b>Front disc diameter and thickness</b>	155 mm-4 mm.
<b>Front brake caliper</b>	1 piston of 30.2 mm.
<b>Brake drum diameter.</b>	110 mm.

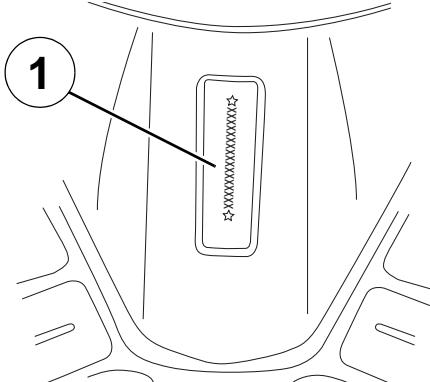
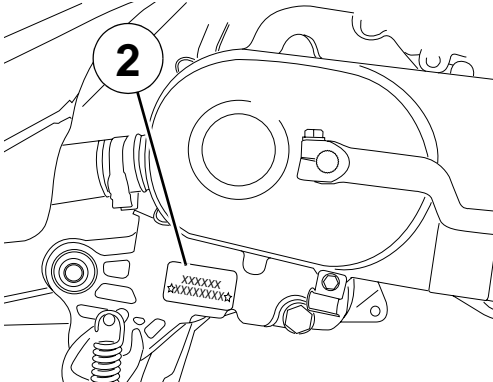
<b>Chassis markings.</b>	<b>Engine marking.</b>
	
1. VIN (Rear shield).	2. Engine number. - Manufacturer's plate (Right side).

**SERVICE SCHEDULE AND COMMISSIONING**

Heavy duty servicing is for vehicles used under "harsh" conditions: door-to-door deliveries, intensive urban use (courier), short journeys with engine cold, dusty areas, ambient temperature over 30°C.

Service operations.	500 kms or 1 months.	At 2000 kms.	Every 5000 kms or 12 months	Every 10000 kms.	Every 20000 kms.
Heavy duty servicing.	500 kms.	At 1000 kms.	Every 2500 kms.	Every 5000 kms.	Every 10000 kms.

**■ Check**

Throttle cable play.	C	C	C	C	C
Steering column play.	C	C	C	C	C
Operation of electrical equipment.	C	C	C	C	C
Condition of the front brake hydraulic control.	C	C	C	C	C
Condition of petrol pipes.	C	C	C	C	C
Condition of oil pipes.	C	C	C	C	C
Tyre pressures.	C	C	C	C	C
Tyre condition, pressure and wear.	C	C	C	C	C
Condition of the front suspension.	C	C	C	C	C
Condition of the rear suspension.	C	C	C	C	C
Brake fluid level.	C	C	C	C	C
Battery electrolyte level*.	C	C	C	C	C
Tightness of nuts and bolts.	C	C	C	C	C

**■ Change**

Spark plug.			R	R	R
Inlet silencer/air filter.					R
Front brake pads #.			C	C	C
Rear brake linings #.			C	C	C
Drive pulley bearings and guides #.			C	C	C
Transmission belt ##.			R	R	R
Engine oil (+ clean strainer).	R	R	R	R	R
Brake fluid.	Once every 2 years				
Relay box.				R	R

**■ Check and lubricate**

Kick starter mechanism.				G	G
Drive pulley/Movable face.				G	G

**■ Test machine**

On road.	C	C	C	C	C
----------	---	---	---	---	---

C : Check  
 N : Clean  
 R : Change  
 G : Check and lubricate

\* Depending on equipment  
 # Change if necessary  
 ## Or once every 5 years

**■ Battery preparation (Except battery without maintenance)\*.**



Remove the battery.

Remove the 6 filler caps and the vent plug.

Fill with electrolyte to the level marked "UPPER LEVEL".

The density shall be equal to  $1.28 \pm 0.01$  Kg/L, that is to say a concentration of 32.3 to 34.7 %.

Peugeot electrolyte P/N: 739733 1/2 l, 752741 5 l.

Leave the battery to stand for around half an hour.

Top up if necessary.

Charge the battery for at least 6 hours with a current of 0.5A.

Refit the battery and connect the vapour vent pipe.

Connect the terminal with the red wire to the battery + and the terminal with the black and white wire to the battery -.

Then, the battery level should be topped up if necessary, after fully charging, using distilled water only.

#### ■ Checks before handing over to the customer.

Check the wheel nuts are tight.

Check nuts and bolts are tight.

Check brake adjustment and efficiency.

Check the tyre pressures cold.

Check operation of the lights, flashers, horn, and brake light.

Check the different warning lights work.

Carry out a road test.

## **SPECIAL IMPORTANT POINTS**

### ■ Oil and fuel.



This engine is designed to run on 95 or 98 unleaded fuel only.

---



Fuel pipes must absolutely be changed if there are any signs of wear, cracks, etc.

---



Petrol is highly inflammable, do not smoke in the working area and avoid proximity to flames or sparks. Work in a clear and well-ventilated area.

Before carrying out any work, leave the engine to cool for at least 2 hours.

---

### ■ Starting up after overhauling the engine.

When starting the engine hot or cold do not accelerate.

**TIGHTENING TORQUES****■ Engine part.**

Cylinder head.	1.8 m.daN
Cylinder casings.	1 m.daN
Transmission cover.	1 m.daN
RH casing cover.	1 m.daN
Automatic tensioner.	0.8/1 m.daN
Starter motor.	1 m.daN
Rotor.	5 m.daN
Stator.	0.8 m.daN
Engine speed sensor.	0.6 m.daN
Drive pulley.	5 m.daN
Driven pulley.	5 m.daN
Spark plug.	1.8 m.daN
Inlet manifold.	1 m.daN

**■ Body panels.**

Front mudguard.	0.8 à 1.2 m.daN
Handlebar cover.	0.2 à 0.4 m.daN
Front shield panels.	0.2 à 0.4 m.daN
Rear shield.	0.2 à 0.4 m.daN
Bottom panel.	1 m.daN
Floor panel.	1 m.daN
Saddle storage compartment.	1 m.daN
Rear panels.	0.2 à 0.4 m.daN
Grab handle.	2.5 m.daN
Rear mudguard.	0.8 à 1 m.daN

### ■ Cycle part

Front wheel spindle.	5.3 m.daN
Rear wheel spindle nut.	12 m.daN
Linkrod to engine pivot.	8 m.daN
Linkrod to frame pivot.	9.8 m.daN
Shock absorber top mount.	2.9 m.daN
Shock absorber bottom mount.	2.9 m.daN
Exhaust to cylinder head mounting nut.	1.8 m.daN
Exhaust to casing mounting bolt.	2.3 m.daN
Upper cone.	Hand tightened
Steering locknut.	3 m.daN
Front brake caliper.	2.6 m.daN
Front brake disc.	2.3 m.daN
Handle bar.	4.9 m.daN

### ■ Standard.

Nut and bolt 5 mm diameter.	0.4 m.daN
Nut and bolt 6 mm diameter.	0.9 m.daN
Nut and bolt 8 mm diameter.	1.2 m.daN
Nut and bolt 10 mm diameter.	2.6 m.daN
Nut and bolt 12 mm diameter.	3.9 m.daN

## INSTRUMENT PANEL

Functions of the instrument panel:

- Speedometer.
- Odometer.
- Fuel gauge.

Instrument panel indicator lamps:

- Intermitent signal.
- High beam.

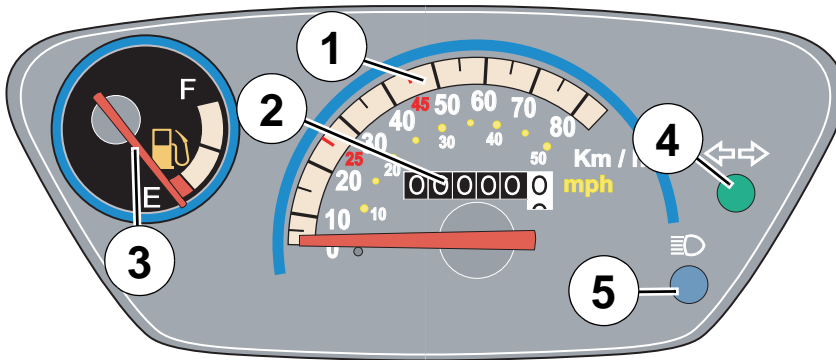

1. Speedometer.
2. Odometer.
3. Fuel gauge.
4. Intermitent signal.
5. High beam.

### ■ Analog functions (hands).

#### Speedometer.

Double-scale indication, kilometres/miles.

#### Odometer.

The odometer displays the number of kilometres travelled by the vehicle.

#### Fuel gauge.



When a flasher bulb has failed the repeater light and the other flasher light flash more quickly to alert the rider of a failure.

**ELECTRICITY****■ Fuses and energy distribution.**

When the main fuse (10A) is blown, all the the electric functions of the vehicle are disabled.  
Replace the burnt out fuse with a new one.

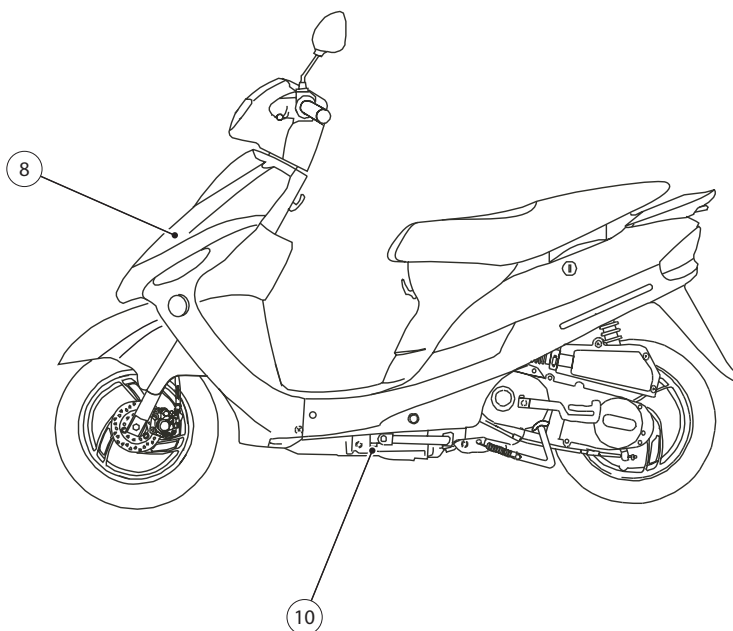
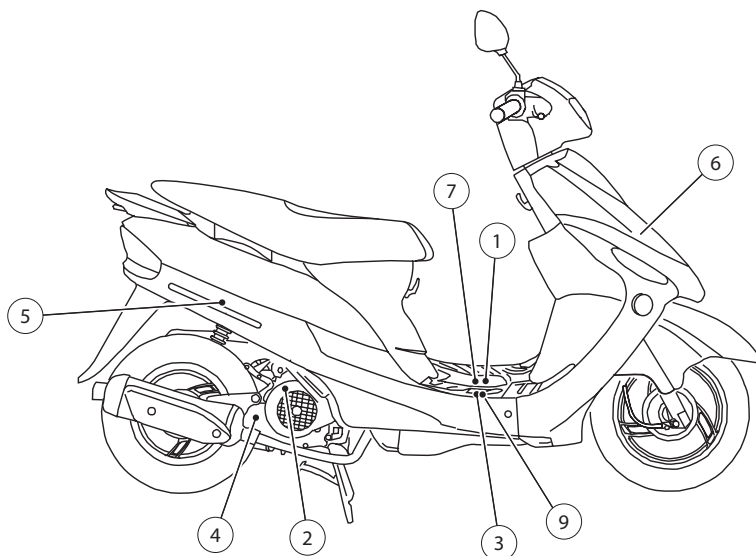
**■ Location of components**

1. Battery.
2. Ignition sensor.
3. Ignition unit.
4. Oil level indicator.
5. HT coil.

6. Regulator.
7. Starter motor relay.
8. Horn.
9. 10 A fuse.
10. Kickstand switch.

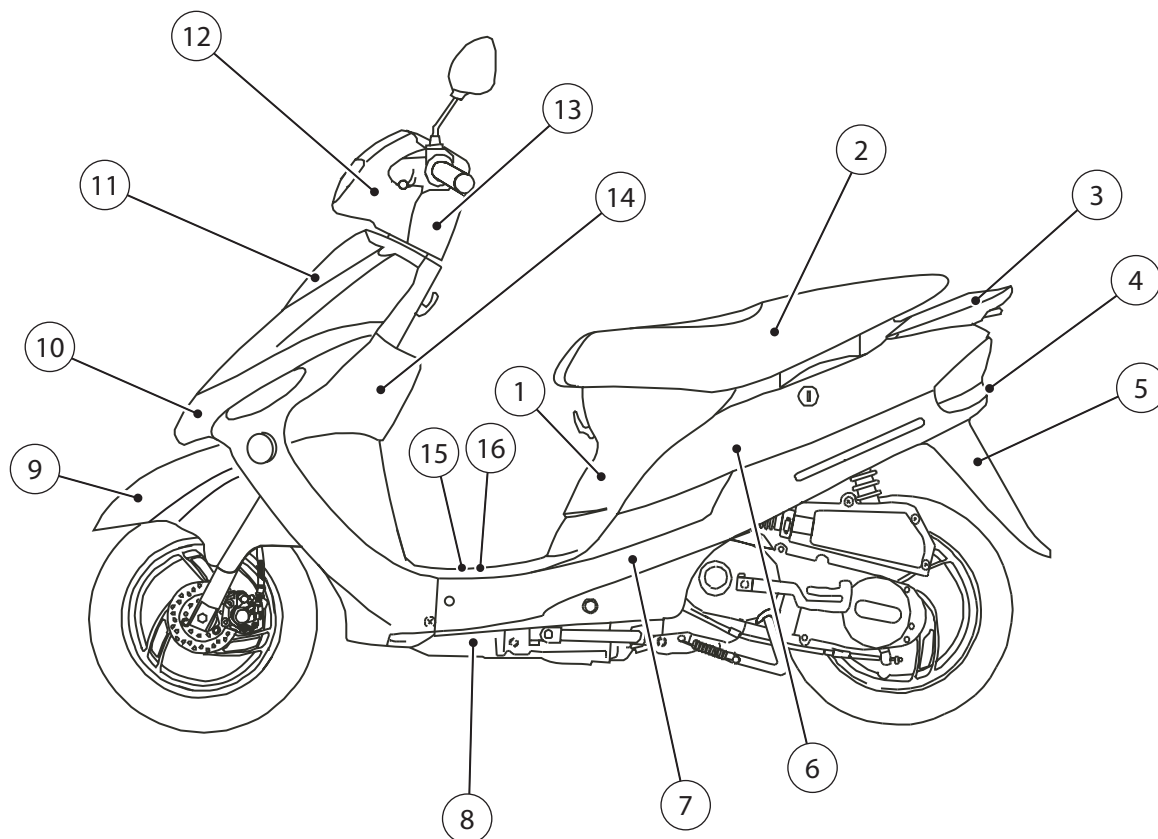
**BODY PANELS****■ Location of body components.**

- |                                |                              |
|--------------------------------|------------------------------|
| 1. Central panel.              | 9. Front mudguard.           |
| 2. Saddle/Storage compartment. | 10. Front shield panels.     |
| 3. Grab handle.                | 11. Front top cover panel.   |
| 4. Rear cover.                 | 12. Handlebar front fairing. |
| 5. Mudflap.                    | 13. Handlebar rear fairing.  |
| 6. Side panels.                | 14. Rear shield.             |
| 7. Lower side fairings.        | 15. Floor panel.             |
| 8. Bottom panel.               | 16. Battery access door.     |

■ Body component sequence of disassembly.

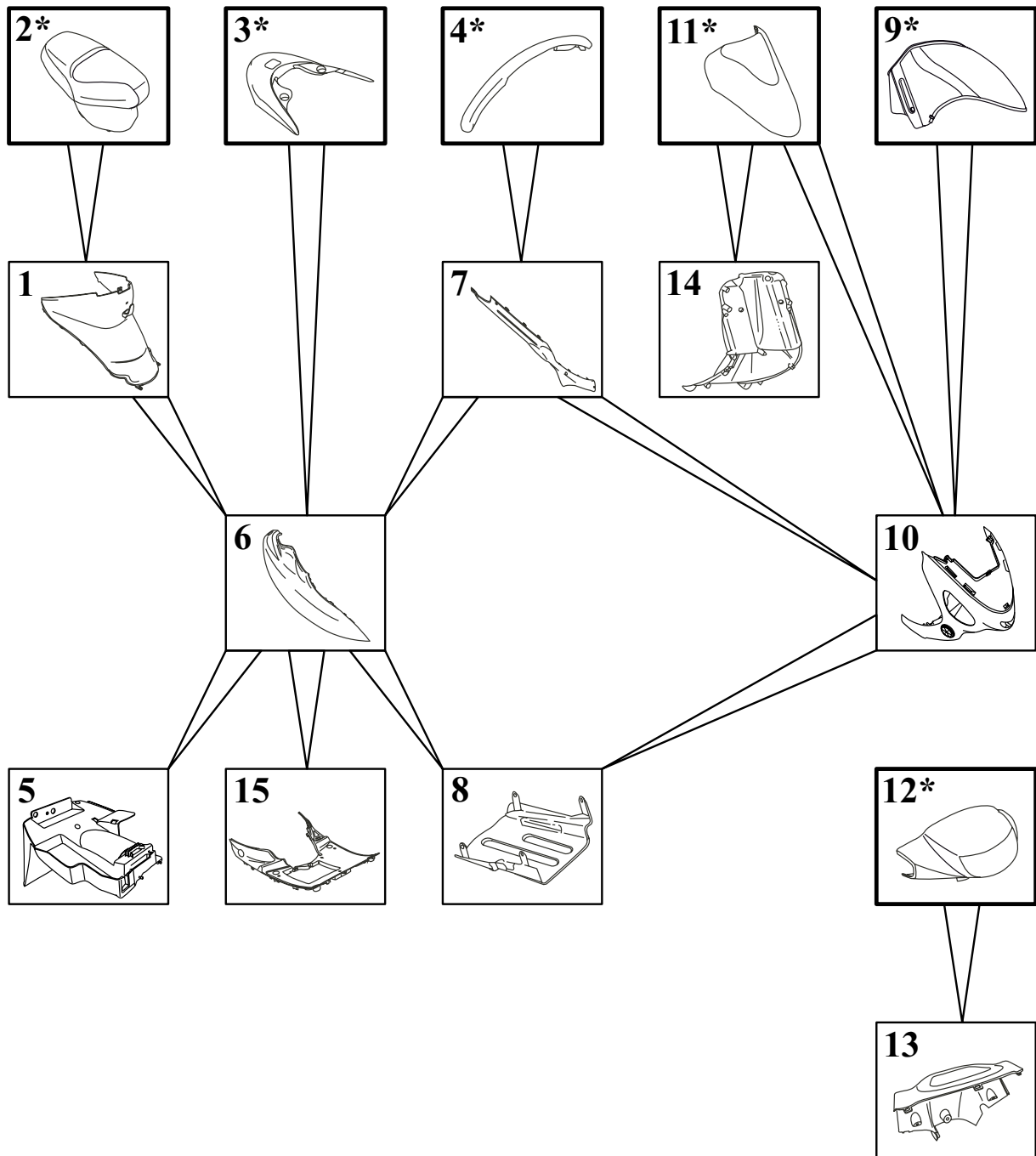

\*This item may be removed on its own.



## ■ Removal of the storage compartment.

### Procedure 1.

- Flip up the seat to the front of the vehicle.
- Remove the 2 nut caps (1).
- Remove the 4 nuts and the 4 washers (2).
- Remove the screw (3).
- Remove the storage compartment.

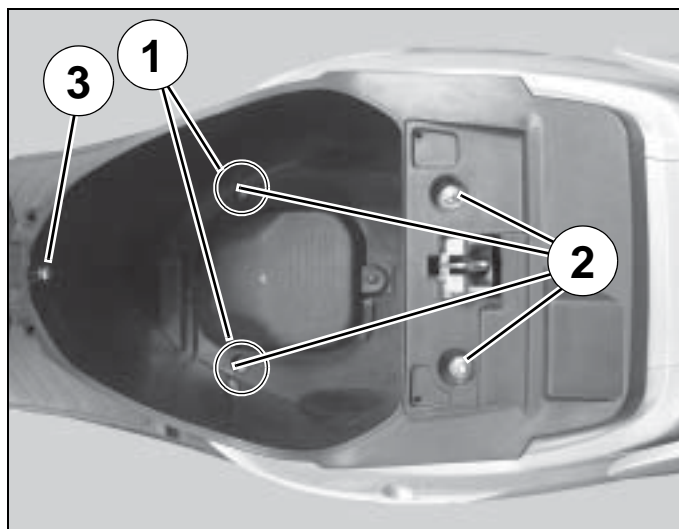

## ■ Removal of the grab handle.

### Procedure 2.

- Remove the plastic cover (1).
- Remove the 3 bolts (2) that secure the grab handle.
- Remove the grab handle (3).

Tightening torque: 2.5 m.daN.

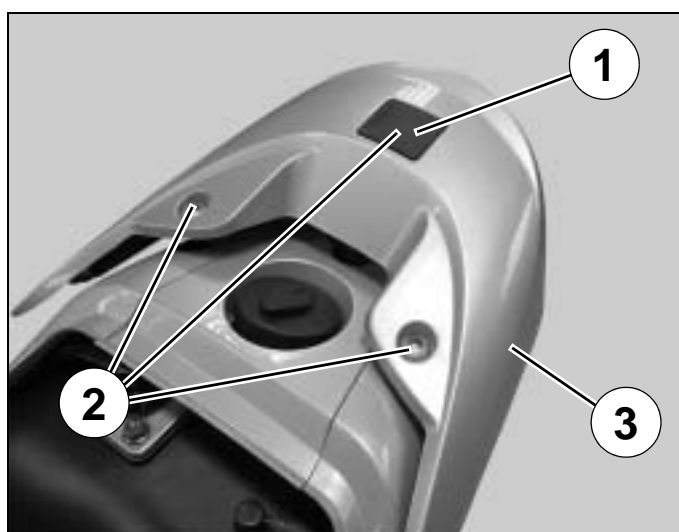

## ■ Removal of the central cover panel.

### Procedure 3.

- Removal of the storage compartment (see procedure 1).
- Remove the footboard mat (1).
- Remove the 4 fixing bolts (2).
- Remove the central cover panel (3).

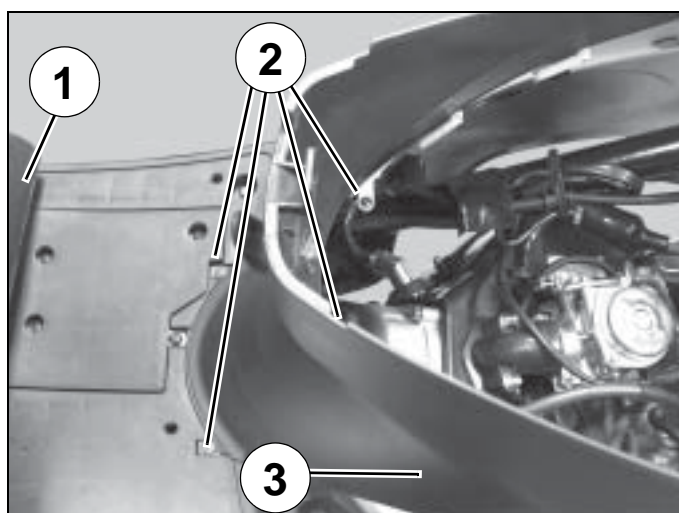

■ **Removal of the lower side fairings.**

**Procedure 4.**

- Remove the 2 screws that secure the rear panel (1).
- Remove the rear body cover.
- Remove the 4 fixing bolts (2).
- Remove the lower side panel (3) by sliding it backwards in order to release it.

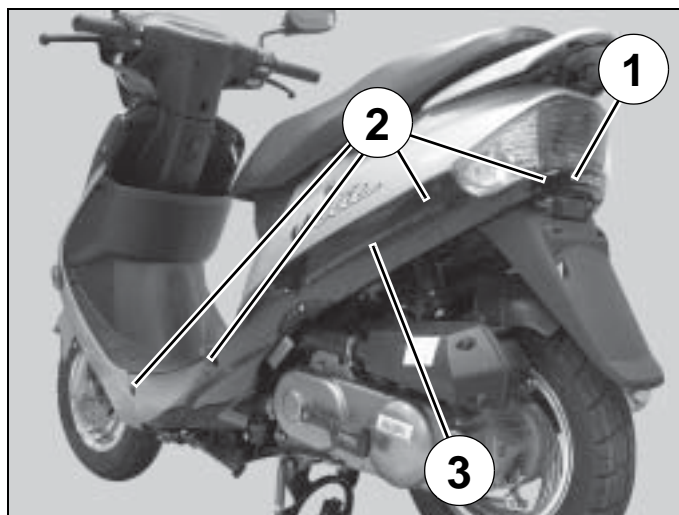

■ **Removal of the side fairings.**

**Procedure 5.**

- Removal of the storage compartment (see procedure 1).
- Removal of the grab handle (see procedure 2).
- Removal of the central cover panel (see procedure 3).
- Removal of the lower side fairings (see procedure 4).
- Remove the fixing screw (1) located on each side of the vehicle.
- Remove the fixing screw (2) located on each side of the vehicle.
- Remove the tank filler cap (3).
- Disconnect from the lock the cable that controls the opening of the saddle.
- Remove the side panels by sliding them backwards in order to release them.

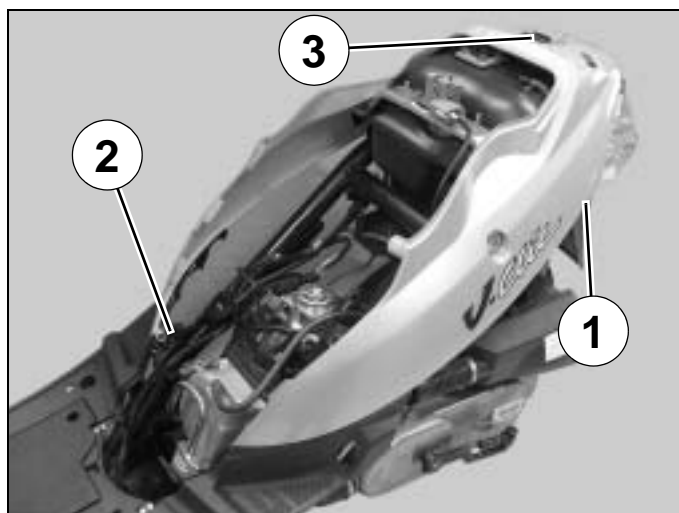

■ **Removal of the footboard.**

**Procedure 6.**

- Removal of the storage compartment (see procedure 1).
- Removal of the grab handle (see procedure 2).
- Removal of the central cover panel (see procedure 3).
- Removal of the lower side fairings (see procedure 4).
- Remove the side fairings (see procedure 5).
- Remove the footboard mat.
- Remove the 4 fixing bolts.
- Remove the battery access door (1).

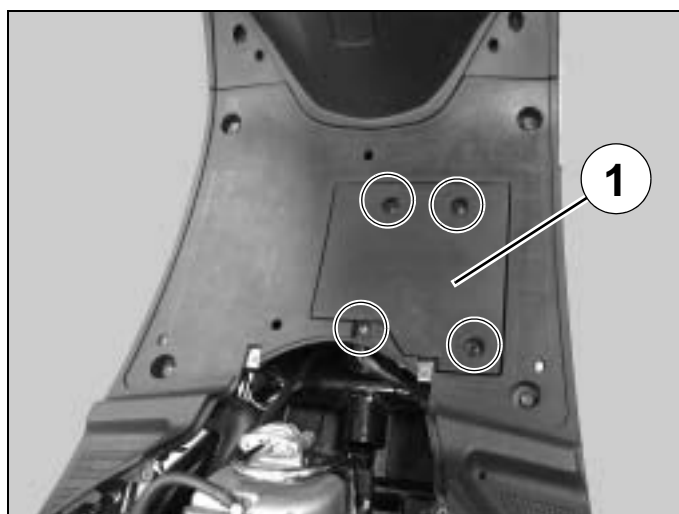

- Disconnect the battery.

Remove:

- The battery (2).
- The CDI unit (3).

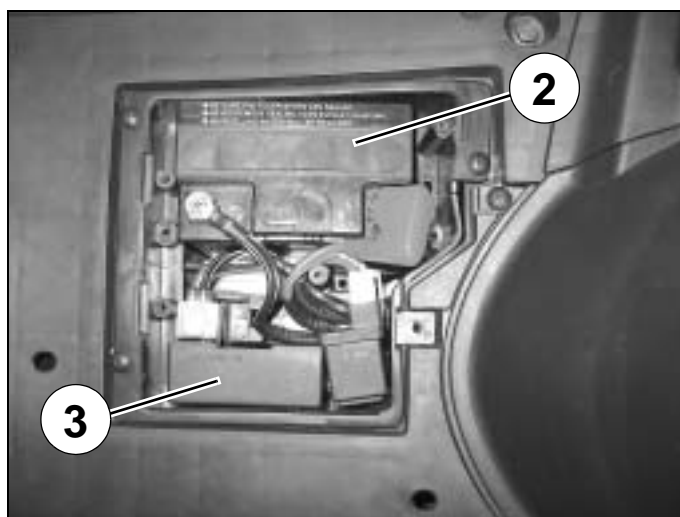

- Remove the 4 fixing bolts (4).
- Separate the front of the footboard which is linked to the rear part of the leg shield panel (5).
- Remove the footboard (6).

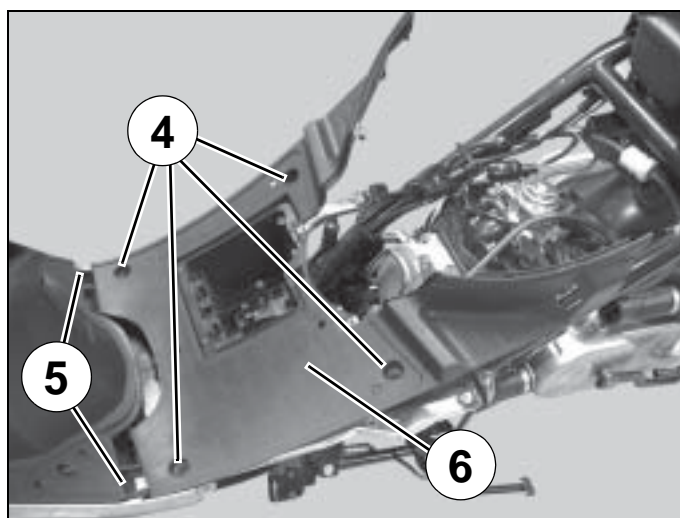

#### ■ Removal of the taillight.

#### ■ Removal of the splash guard.

- Removal of the storage compartment (see procedure 1).
- Removal of the grab handle (see procedure 2).
- Removal of the central cover panel (see procedure 3).
- Removal of the lower side fairings (see procedure 4).
- Removal of the side fairings (see procedure 5).
- Disconnect the taillight.
- Remove the 2 nuts (1).
- Remove the 2 bolts (2).
- Remove the taillight.

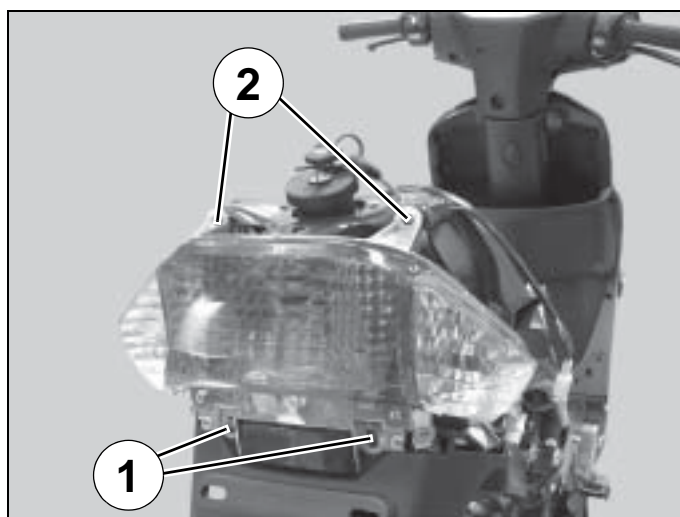

- Remove the splash guard by releasing it from the pins (3) and bracket (4).

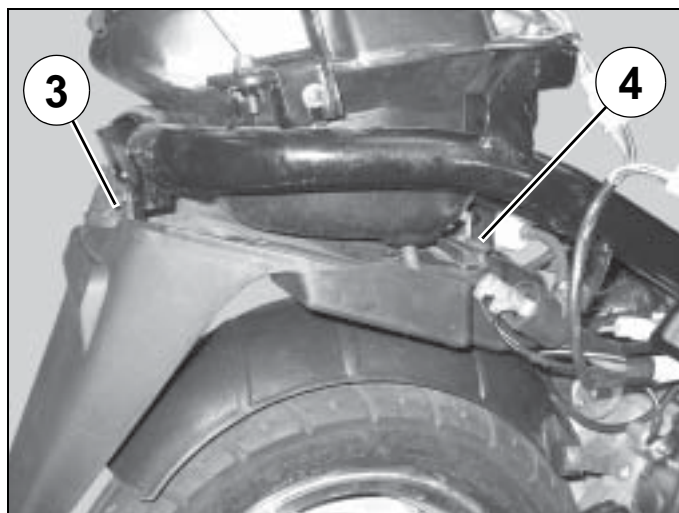

■ **Removal of the front top cover panel.**

**Procedure 7.**

- Remove the 4 fixing bolts (1).

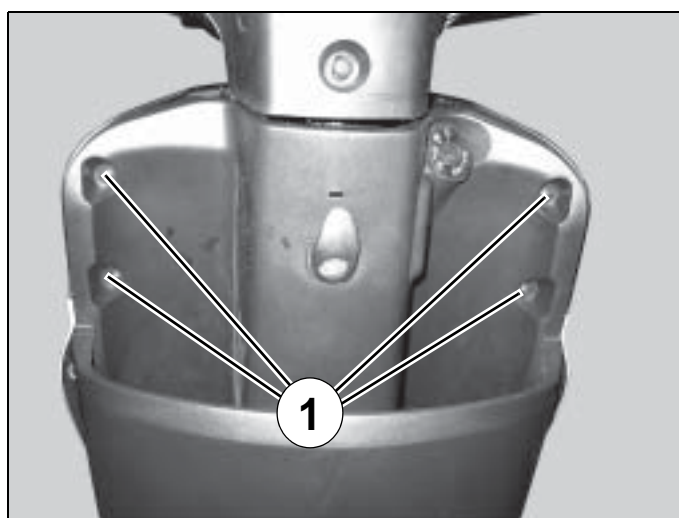

- Unclip the front cover panel from on top of the front leg shield panel.
- Remove the front top cover panel (2).

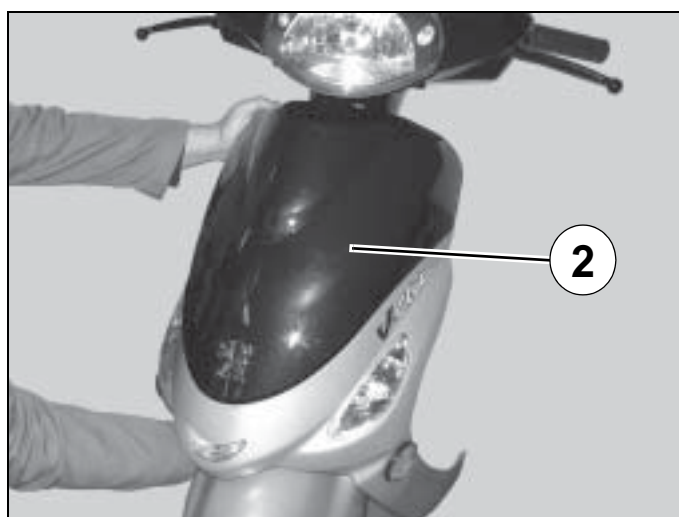



## ■ Removal of the front mudguard.

### Procedure 8.

- Disconnect the speedometer driver control cable.
- Remove the wheel.
- Remove the fixing screw (1) located on each side of the vehicle.
- Remove the front part of the mudguard (2) by unclipping it from the holder (3).

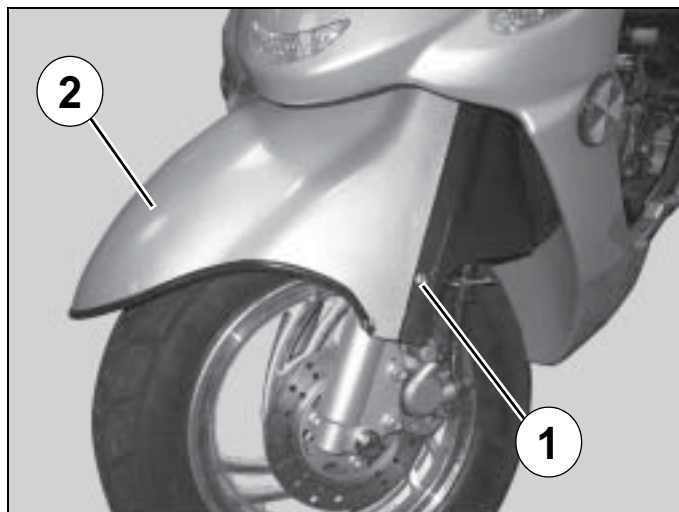

- Remove the 2 fixing bolts (4).
- Remove the rear part of the mudguard and its holder.

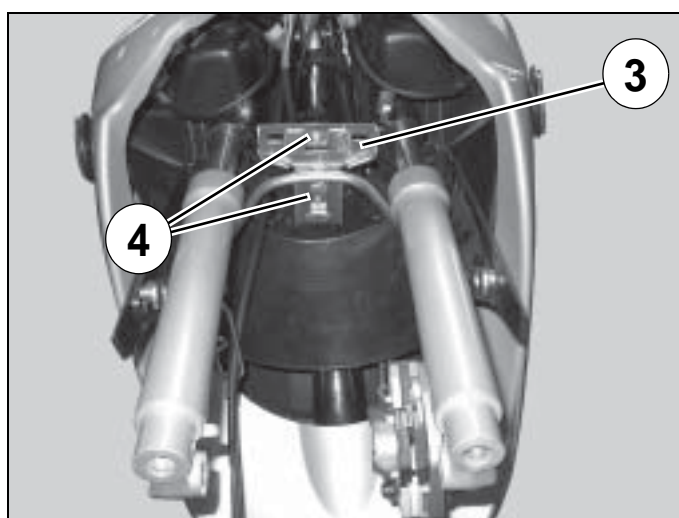

## ■ Removal of the front shield panel.

### Procedure 9.

- Removal of the lower side fairings (see procedure 4).
- Removal of the front top cover panel (see procedure 7).
- Removal of the front mudguard (see procedure 8).
- Remove the 6 fixing bolts.

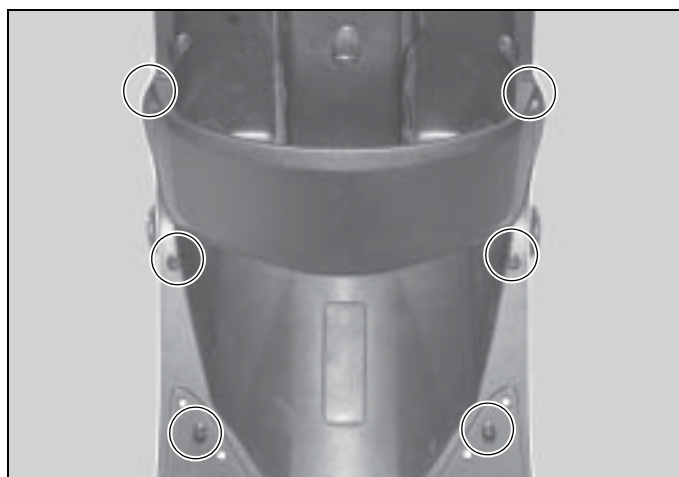

- Remove the 2 fixing bolts (1).
- Remove the front shield panel (2).

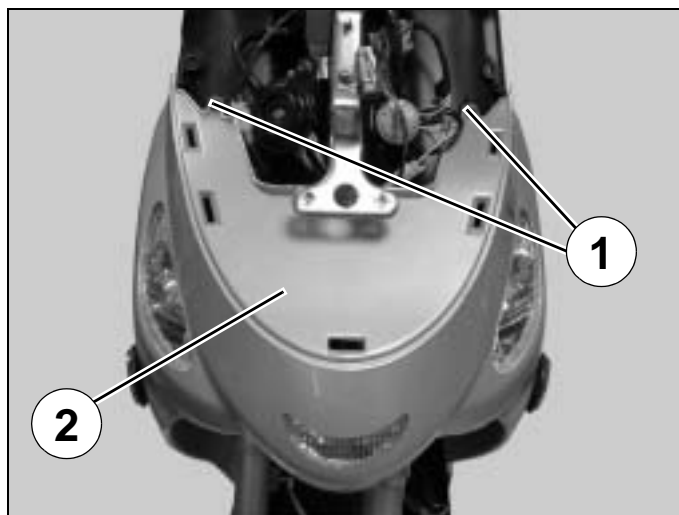

■ **Removal of the rear shield panel.**

**Procedure 10.**

- Removal of the lower side fairings (see procedure 4).
- Removal of the front top cover panel (see procedure 7).
- Remove the footboard mat.
- Remove the ignition switch trim.
- Remove the 3 fixing screws (1) located on each side of the vehicle.
- Remove the fixing screw (2) located on each side of the vehicle.
- Remove the 2 fixing bolts (3).
- Remove the screw of the utility hanger (4).
- Remove the utility hanger.
- Remove the rear shield panel.

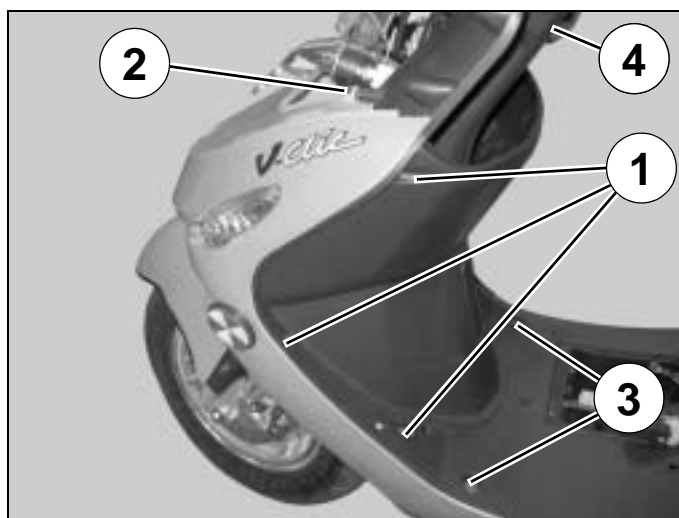

■ **Removal of the under body panel.**

**Procedure 11.**

- Removal of the lower side fairings (see procedure 4).
- Removal of the front top cover panel (see procedure 7).
- Remove the 3 fixing screws (1) located on each side of the vehicle.
- Open the front shield panel.
- Remove the 3 nuts and the screw of the underbody panel.
- Remove the bottom panel (2).

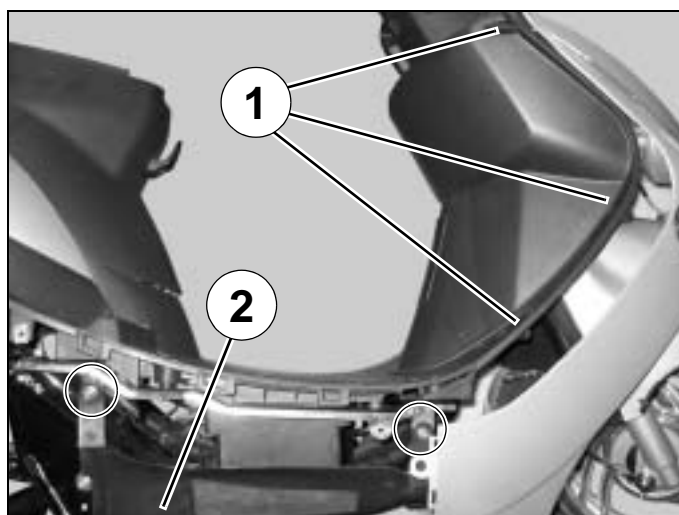

■ **Removal of a headlight bulb.**

- Remove the fastening screw (1).
- Remove the 2 fixing bolts (2).
- Remove the handlebar front cover.

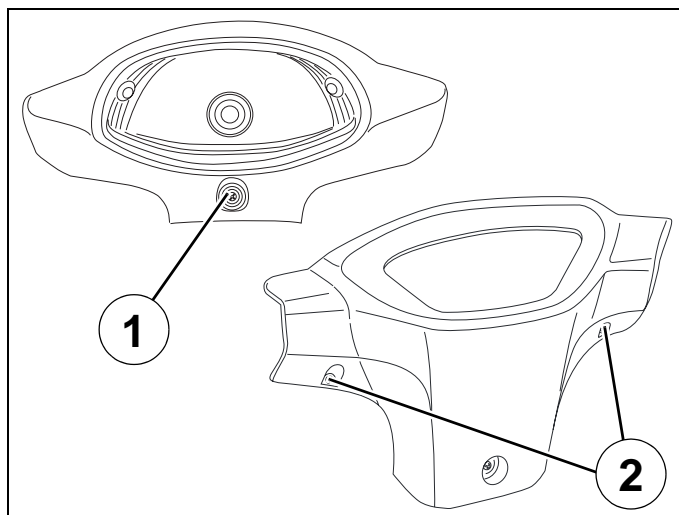

- Remove the lamp lens (3).
- Disconnect the bulb.
- Remove the bulb.

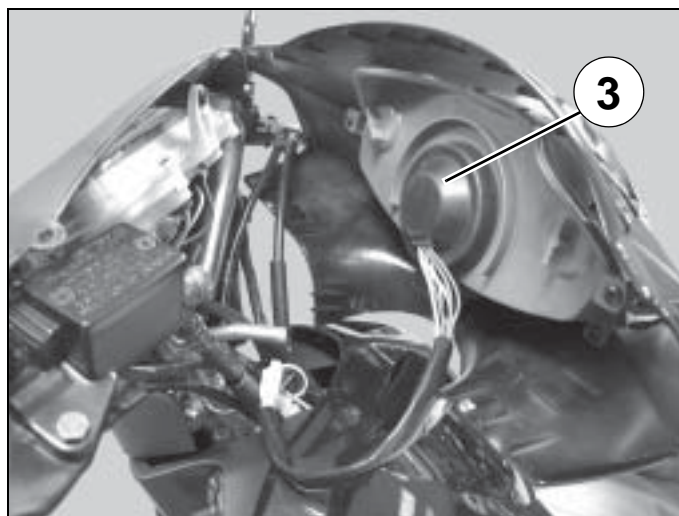

■ **Removal of a taillight bulb.**

- Remove the 2 screws that secure the rear panel.
- Remove the rear body cover (1).
- Remove the 2 screws that secure the taillight lens (2).
- Disconnect the bulb.
- Remove the taillight lens and turn signal light lenses.
- Remove the bulb.

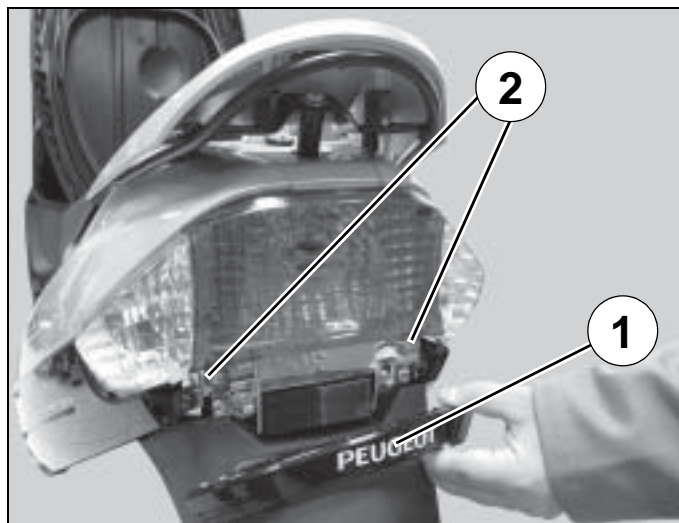

■ **Removal of a turnsignal light.**

- Removal of the lower side fairings (see procedure 4).
- Removal of the front top cover panel (see procedure 7).
- Remove the 3 fixing screws (1) located on each side of the vehicle.
- Remove the fixing screw (2) located on each side of the vehicle.

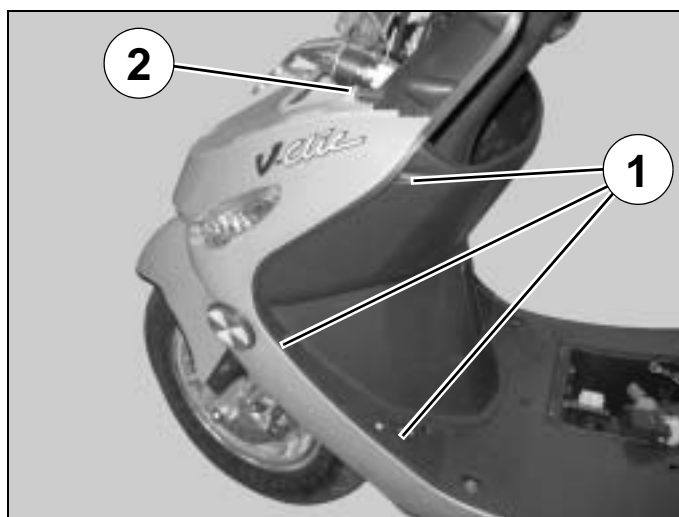

- Open the front shield panel.
- Remove the 3 screws that secure the front turnsignal light.
- Remove the front turnsignal light.

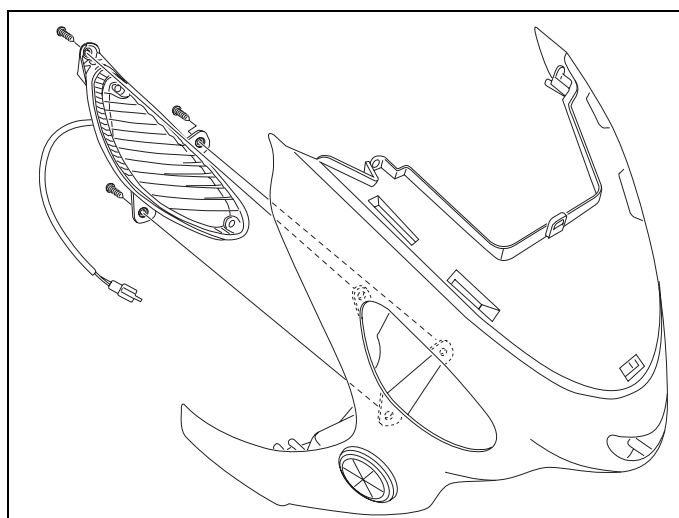



**WORKING ON THE ENGINE WITHOUT REMOVING THE ENGINE****■ Removal of the air filter foam.**

- Remove the 6 screws from the air filter cover (1).
- Remove the air filter cover (1).
- move the air filter foam.
- Change if necessary.

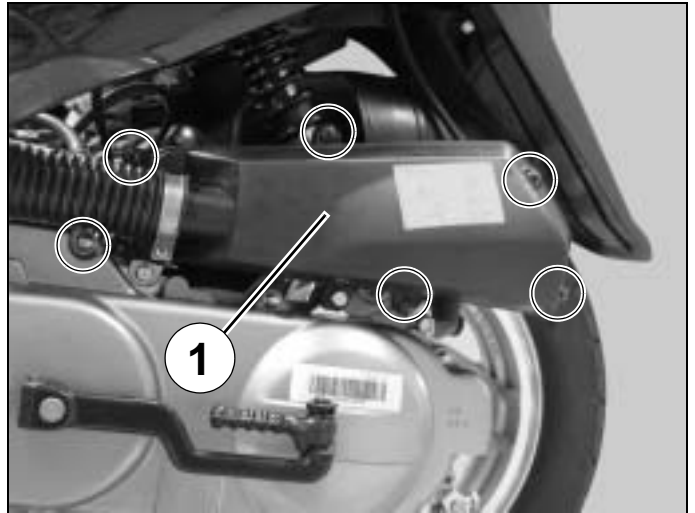
**■ Removal of the transmission filter.**

- Loosen the collar (1).
- Remove the transmission filter sleeve (2).
- Remove the transmission air filter (3).
- Change if necessary.

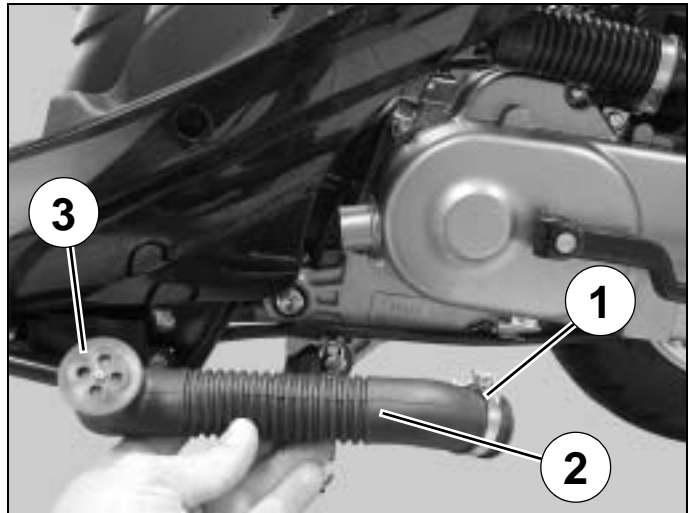
**■ Removal of the fuel filter.**

- Removal of the storage compartment (see procedure 1).
- Removal of the fuel filter (1).
- Change if necessary.

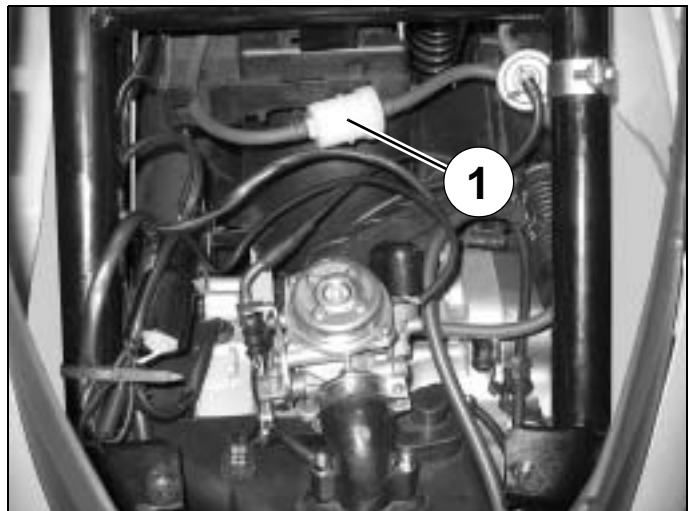

### ■ Removal of the pulsair filter.

### ■ Removal of the pulsair reed valve.

- Removal of the storage compartment (see procedure 1).
- Removal of the central cover panel (see procedure 3).
- Remove the pulsair filter (1).
- Removal of the pulsair reed valve (2) (**Refer to the workshop manual: 2-valve, 50cc 4-stroke engine P/N 759517**).

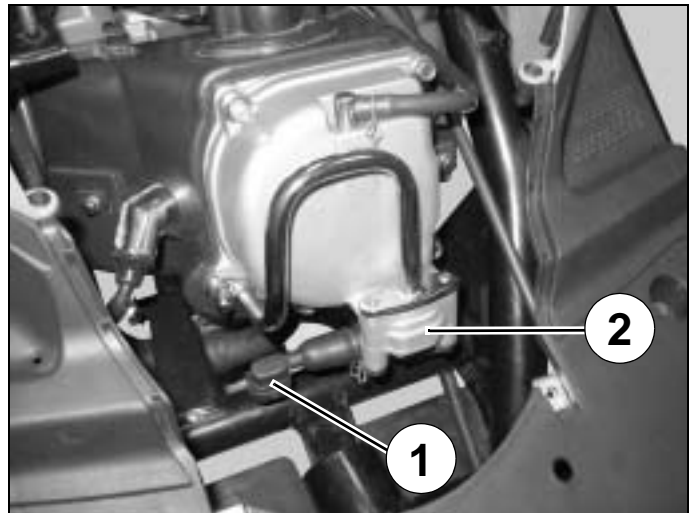

### ■ Removal of the spark plug.

- Removal of the storage compartment (see procedure 1).
- Removal of the central cover panel (see procedure 3).
- Disconnect the suppressor (1).
- Remove the spark plug.

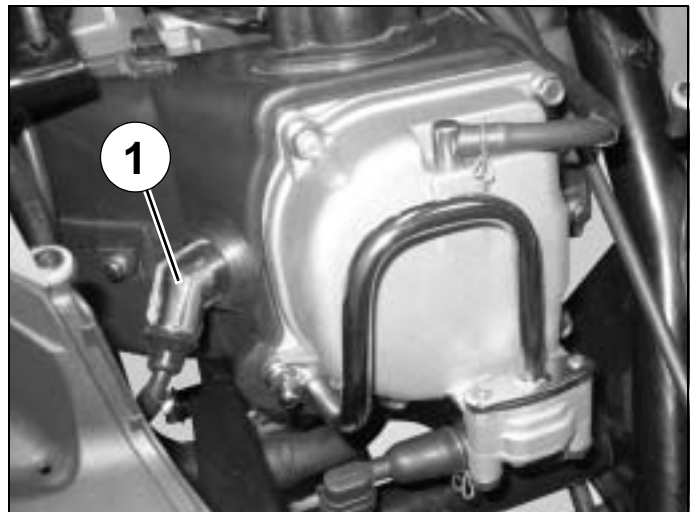

### ■ Removal of the carburettor.

- Removal of the storage compartment (see procedure 1).
- Loosen the collars (1).
- Disconnect the fuel supply hose (2).
- Pull the throttle control cable (3) out of the carburettor.
- Disconnect the electric choke (4).

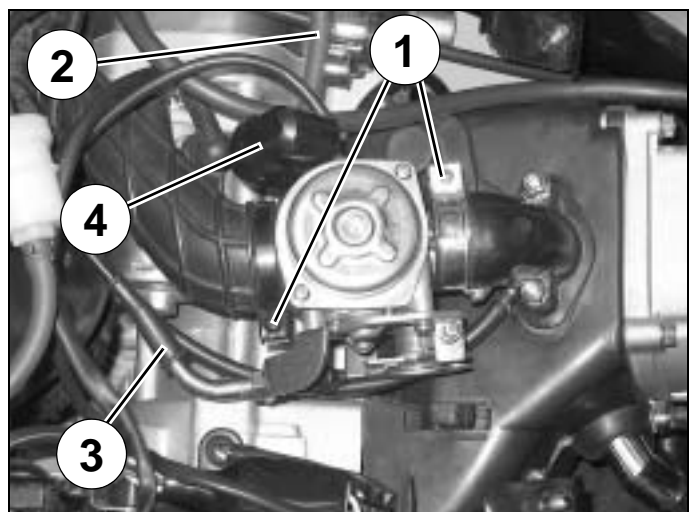

### ■ Installing the valve clearance.

- Removal of the storage compartment (see procedure 1).
- Removal of the central cover panel (see procedure 3).
- Remove the 4 fixing bolts (1).
- Remove the 2 fixing bolts (2).
- Disconnect the oil vapour return pipe.

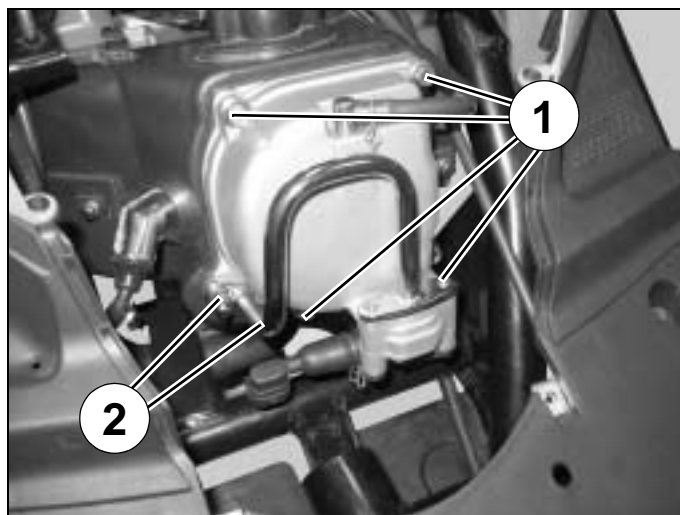

**Tightening torque: 1 m.daN.**

- Remove the rocker cover.
- Remove the timing mark plug (1).
- Installing the valve clearance (**Refer to the workshop manual: 2-valve, 50cc 4-stroke engine P/N 759517**).

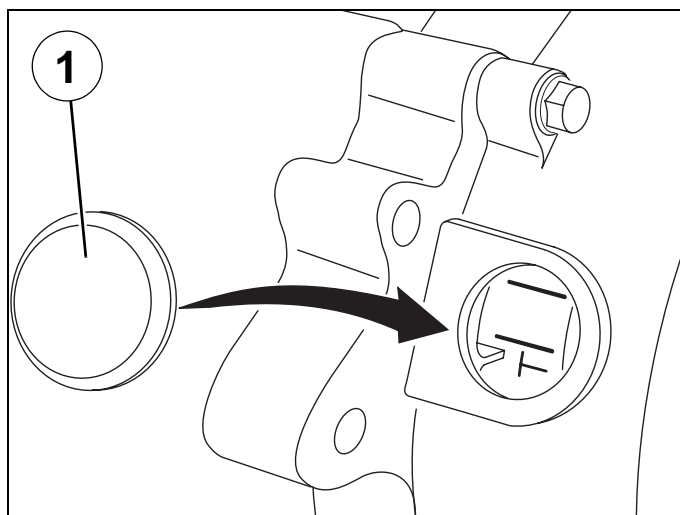

### ■ Removal of the exhaust system.

- Remove the 2 nuts (1).
- Remove the 2 fixing bolts (2).
- Remove the exhaust.
- Removal of the gasket.

**Tightening torque:**

**Screw 1: 1.5 m.daN.**

**Screw 2: 2.3 m.daN.**

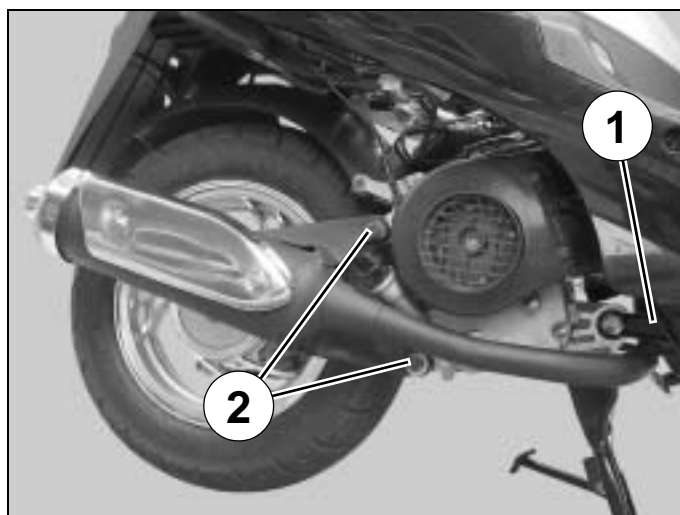

---

■ **Removal of the cylinder head.**

■ **Removal of the cylinder / piston.**

- Removal of the storage compartment (see procedure 1).
- Removal of the central cover panel (see procedure 3).
- Removal of the exhaust system.

For the following steps:

- Removal of the intake pipe.
- Removal of the cooling volutes.
- Removal of the rocker cover.
- Removal of the chain tensioner.
- Removal of the cylinder head.
- Removal of the cylinder.
- Removal of the piston.

**Refer to the workshop manual: 2-valve, 50cc 4-stroke engine P/N 759517.**

## **MISCELLANEOUS OPERATIONS**

### **■ Removal of the engine.**

- Removal of the storage compartment (see procedure 1).
- Removal of the central cover panel (see procedure 3).
- Removal of the carburettor (see page 25).
- Disconnect the vacuum hose.
- Disconnect the oil vapour return pipe.
- Remove the 2 screws that secure the air filter.
- Remove the air filter.
- Disconnect:
  - The suppressor.
  - The magneto.
  - The starter motor.
- Suspend or immobilize the machine securely.
- Remove the shock absorber lower mount .
- Remove the nut that secures the engine.
- Remove the bolt that secures the engine.
- Remove the engine.

### **■ Removal of the battery.**

### **■ Removal of the starter motor relay.**

### **■ Removal of the ignition module (CDI).**

### **■ Removal of the fuse.**

- Remove the footboard mat.
- Remove the 4 fixing bolts.
- Remove the battery access door.





- **Removal of the regulator.**
- **Removal of the choke resistor.**
- **Removal of the horn.**
- **Removal of the blinker unit.**
- **Removal of the ignition switch.**
  - Removal of the front top cover panel (see procedure 7).

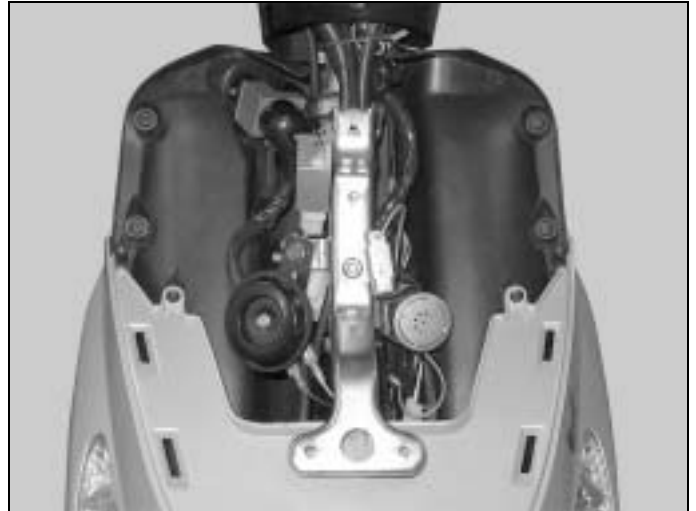

- **Removal of the high tension coil.**
  - Removal of the storage compartment (see procedure 1).
  - Removal of the central cover panel (see procedure 3).
  - Remove the lower RH side fairing (see procedure 4).
  - Disconnect the high voltage coil (1).
  - Disconnect the suppressor.
  - Remove the fastening screw (2).
  - Remove the high tension coil.

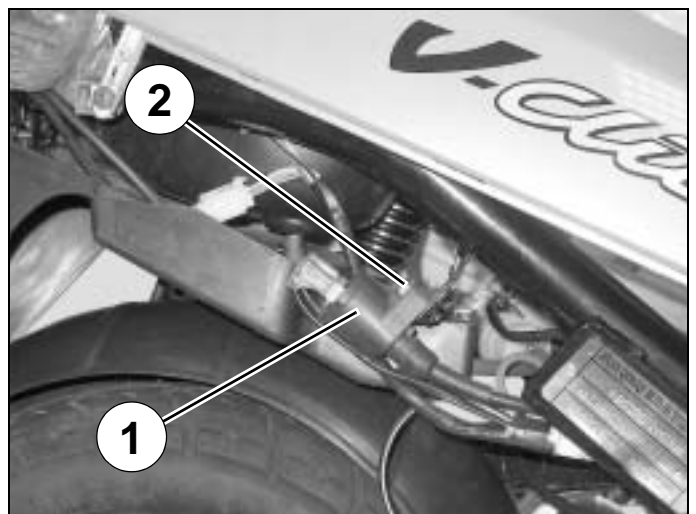

- **Removal of the kickstand contact switch.**
  - Remove the lower LH side fairing (see procedure 4).
  - Disconnect the kickstand contact switch.
  - Remove the 2 fixing bolts (1).
  - Remove the kickstand contact switch.

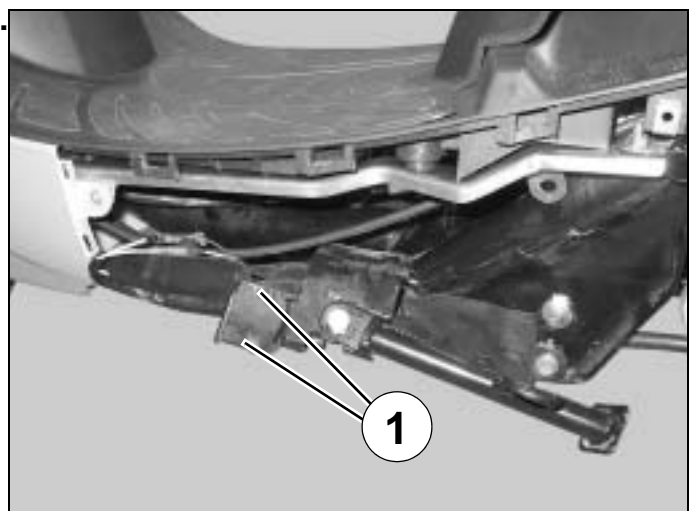

### ■ Removal of the fuel gauge.

### ■ Removal of the tank.

- Removal of the storage compartment (see procedure 1).
- Removal of the grab handle (see procedure 2).
- Removal of the central cover panel (see procedure 3).
- Removal of the lower side fairings (see procedure 4).
- Removal of the side fairings (see procedure 5).
- Disconnect the fuel gauge (1).
- Remove the 4 fixing bolts (2).
- Remove the fuel gauge.
- Remove the flat gasket.
- Remove the 2 fixing bolts (2).
- Remove the 2 nuts (3).
- Remove the holder and saddle lock assembly (4).
- Loosen the 2 nuts (5).
- Remove the 2 fixing bolts (6).
- Remove the grab handle holder.
- Remove the tank.

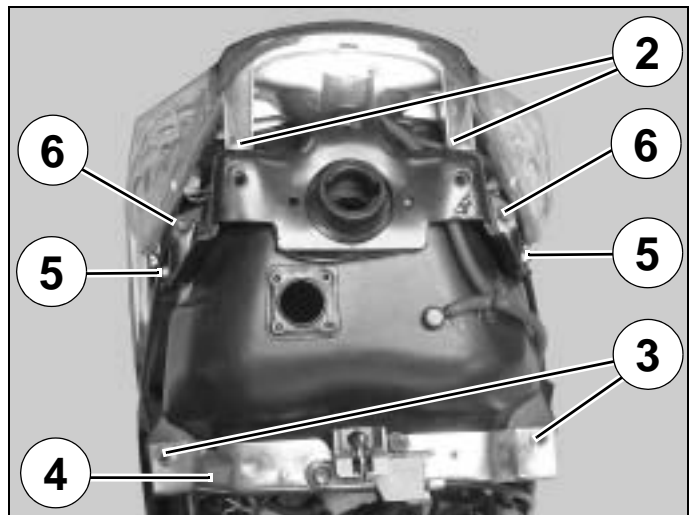
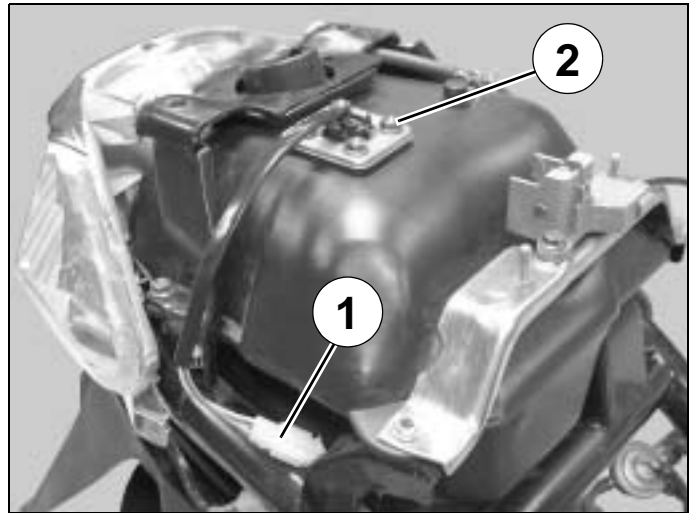

### ■ Removal of the front wheel.

- Unscrew the speedometer cable from the drive system (1).
- Remove the wheel spindle nut.
- Remove the wheel.
- Remove the spacer.
- Remove the speedometer driver (2).

**Tightening torque: 5.3 m.daN.**

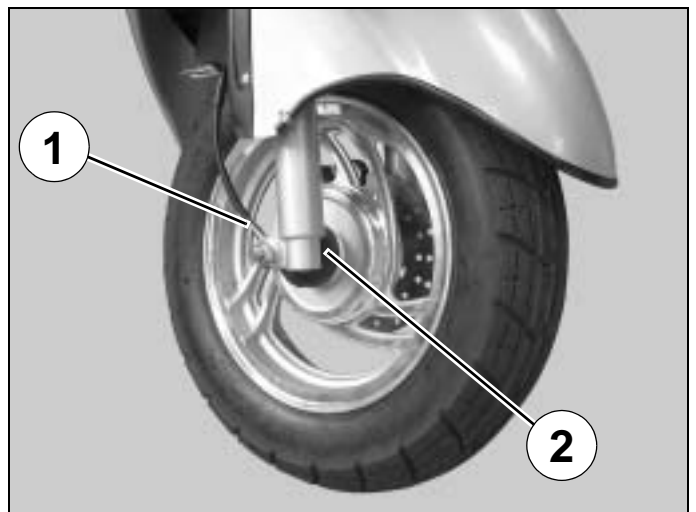

■ **Removal of the rear wheel.**

- Removal of the exhaust system (see page 25).
- Remove the nut and the washer (1).
- Remove the wheel.

**Tightening torque: 12 m.daN.**

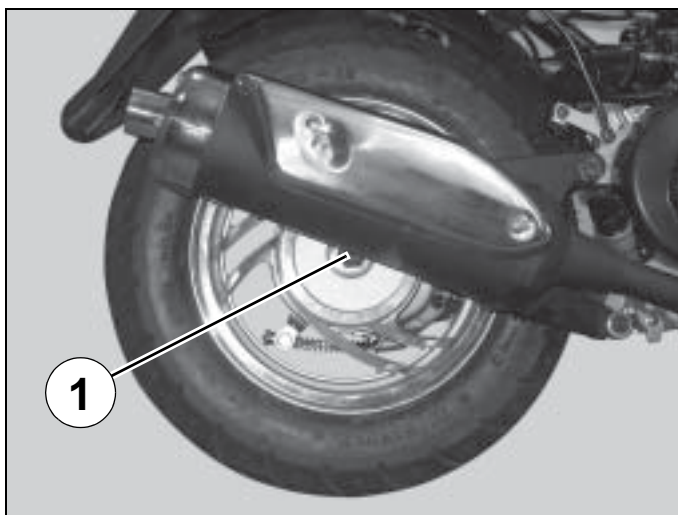

■ **Removal of the calliper.**

■ **Removal of the brake pads.**

- Loosen the screw (1) that secures the calliper to the yoke.
- Remove the 2 screws that secure the brake calliper, but do not disconnect it (2).

**Tightening torque: 2.6 m.daN.**

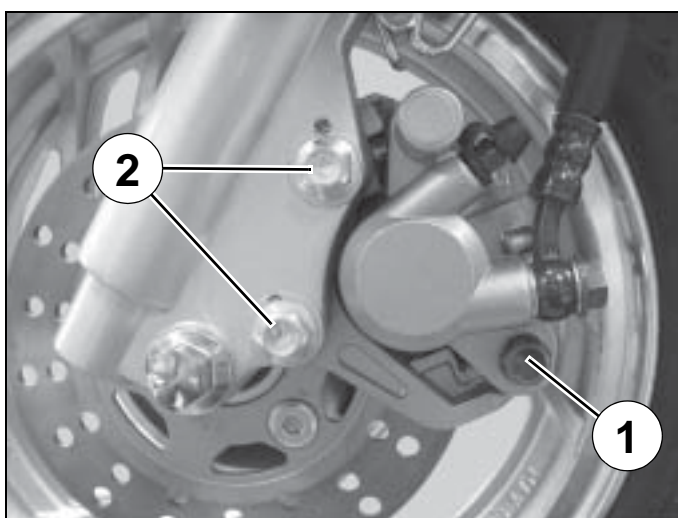

- Remove the screw (1).
- Pivot the calliper relative to the yoke.
- Remove the calliper yoke.

**Note: If the caliper is to be changed, the hydraulic control must be slacked off before removal.**

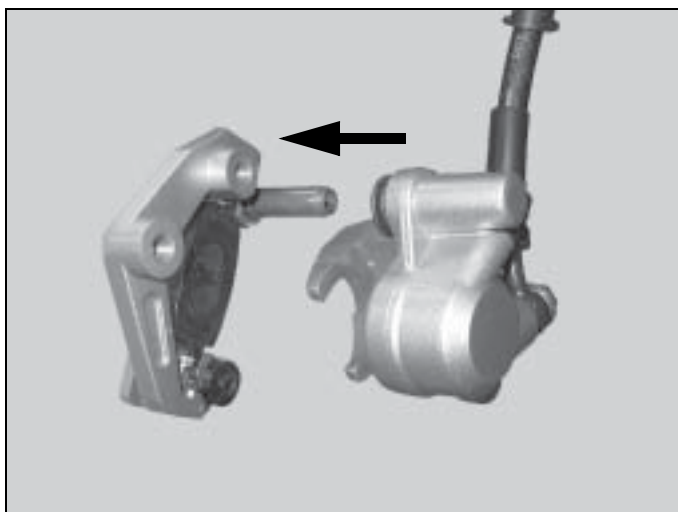



**Reassembly:**

- Install the springs (3) as shown.
- Install the brake pads (4) oriented as shown (flat side (5) oriented towards the rear of the yoke).

**Note:** When refitting the brake pads, push the piston all the way into its housing.

**Note:** After refitting, actuate the brake levers several times to bring the brake pads against the brake disc.

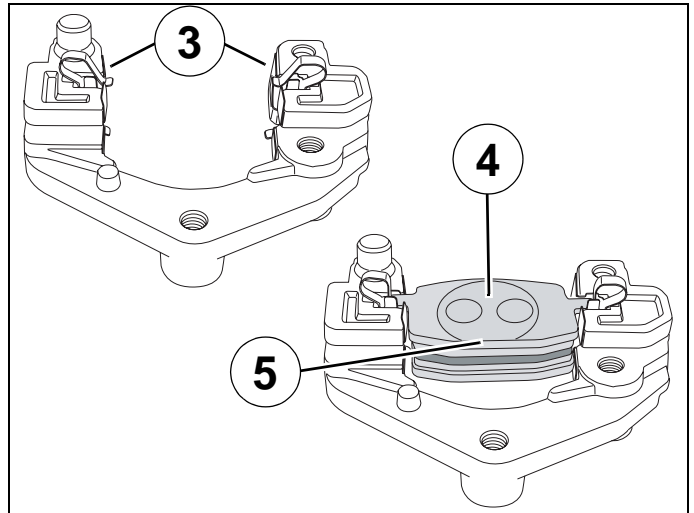

### ■ Removal of the fork.

#### ■ Replacing the bearings of the steering system.

- Removal of the front wheel (see page 29).
- Removal of the front mudguard (see procedure 8).
- Removal of the calliper (see page 30).
- Removal of the front top cover panel (see procedure 7).
- Remove the 3 fixing bolts (1).
- Remove the fastening screw (2).
- Remove the handlebar front and rear covers.
- Remove the handlebars from the fork tube.
- Remove the handlebars from the fork tube.
- Remove the steering locknut (1) (1).
- Remove:
  - The lock washer (2).
  - the adjustable cone (3).
- Remove the fork.
- Remove the balls.

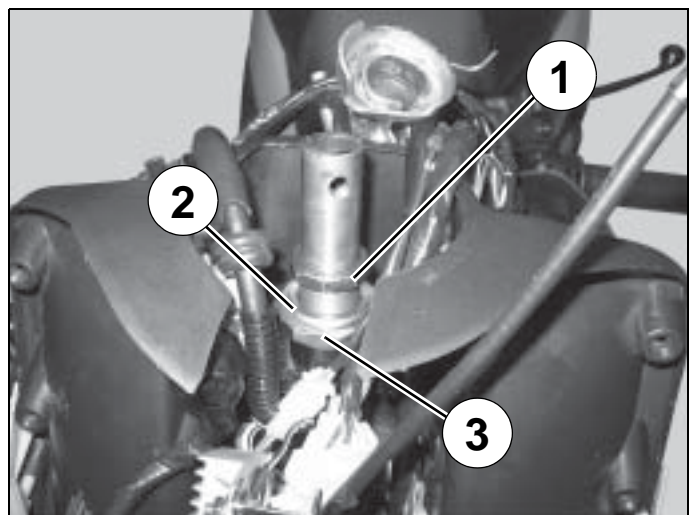
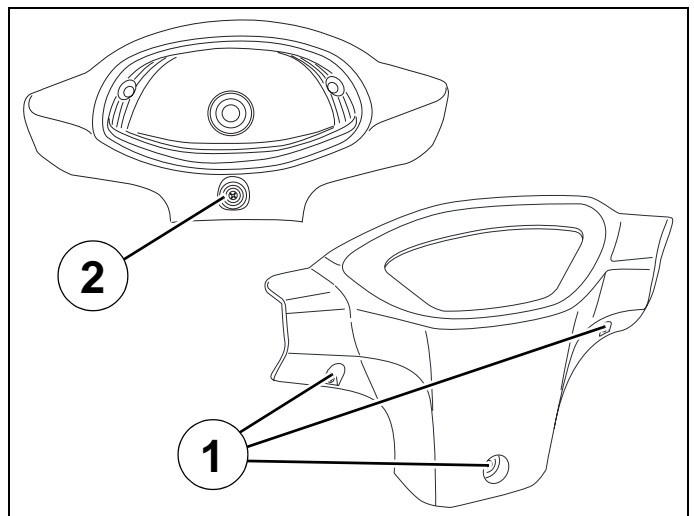

- Using a drift, remove the steering head cups.
- Using a drift, remove the steering headset cone (1).

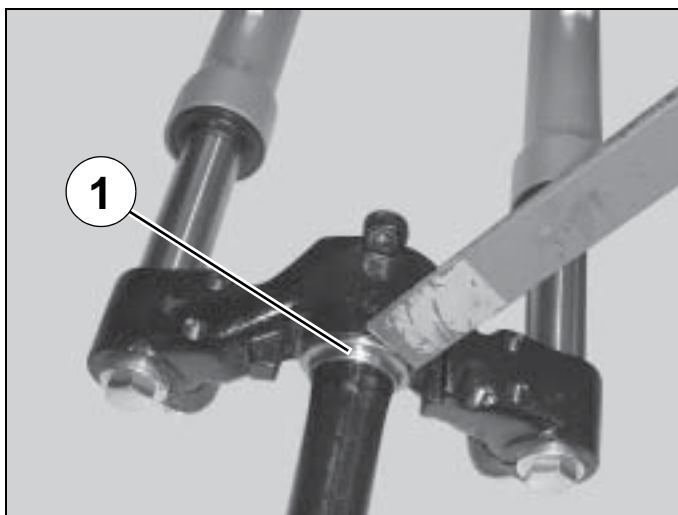

- Install the following new parts:
  - The fork cone (1).
  - The steering headset cups (2).

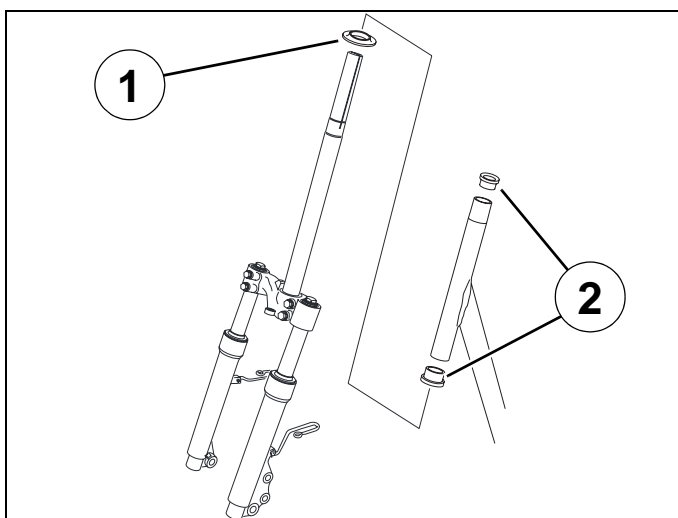

■ **Steering system tightening method.**

- Grease the cup bearing races.
- Fit 26 balls (1) for the upper cup and 29 balls (2) for the lower cup (Diameter: 4 mm).
- Fit the fork into the steering column.
- Install the adjustable cone and tighten it (3).
- Loosen and then retighten the adjustable cone.
- Fit the lock washer (4).
- Install the steering head locknut and tighten it (5).

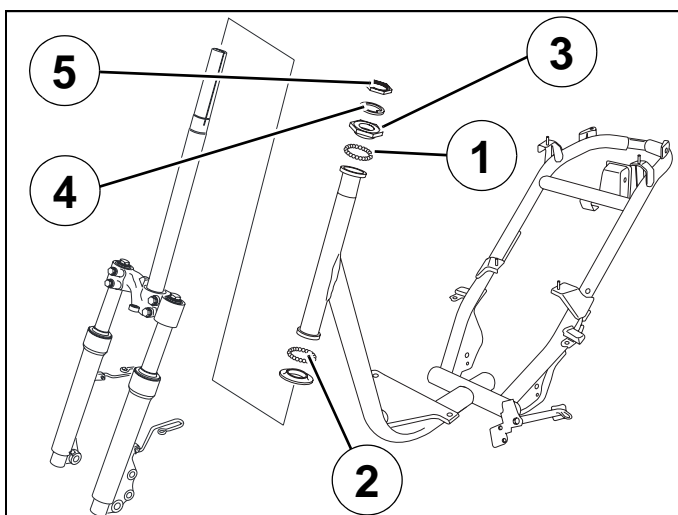

**Tightening torque: 3 m.daN.**







 **UTAC**  
CERTIFICATION  
SYSTEMES QUALITE  
ISO 9001  
Certificat n° SQ/0766-3

P/N 759522

*In our permanent concern to make improvements PEUGEOT MOTOCYCLES reserves the right to suppress, modify, or add any reference mentioned*

*DC/PS/APV Printed in the E.U. 03/2007 (non contractual pictures).*

