

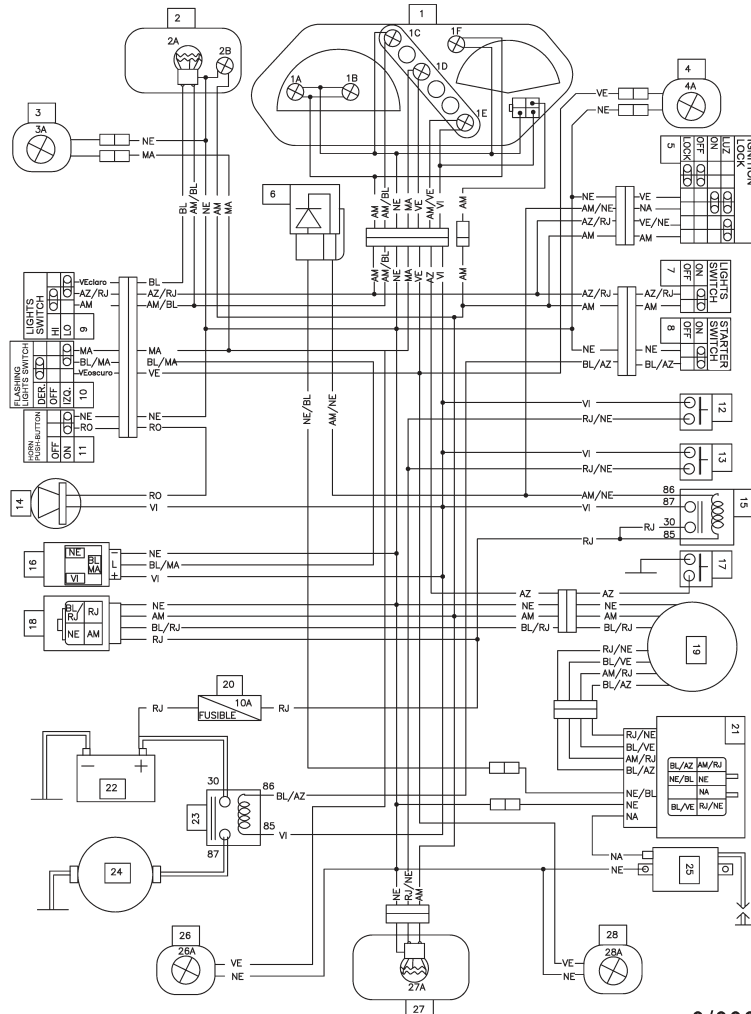

## I.15 ELECTRIC DIAGRAM 2002



0/000.160.6001

NOMENCLATURE OF THE COMPONENTS	
1	INSTRUMENT PANEL
1A	LIGHTING LAMP C/km 12V 1,2W
1B	RESERVE TANK CONTROL LAMP 12V 1,2W
1C	FLASHING LIGHTS CONTROL LAMP 12V 1,2W
1D	INTENSIVE CONTROL LAMP 12V 1,2W
1E	NEUTER CONTROL LAMP 12V 1,2W
1F	LAMP 12V 1,2W
2	HEAD LIGHT
2A	MAIN LAMP 12V 55/60W
2B	POSITION LAMP 12V 5W
3	HEAD LEFT FLASHING LIGHT
3A	FLASHING LAMP 12V 10W
4	HEAD RIGHT FLASHING LIGHT
4A	FLASHING LAMP 12V 10W
5	IGNITION LOCK
6	DIODE OF ENGINE STOPPAGE
7	LIGHTS SWITCH
8	STARTER PUSH-BUTTON
9	INTENSIVE AND DIPPED HEADLIGHTS SWITCH
10	FLASHING LIGHT SWITCH
11	HORN PUSH-BUTTON
12	FRONTAL BRAKE LIGHTS
13	REAR BRAKE LIGHTS
14	HORN DC 12V
15	IGNITION RELAY
16	CENTRAL FLASHING LIGHT 12V 2X10W
17	NEUTER SWITCH
18	VOLTAGE REGULATOR AC-DC 12V
19	MAGNETIC FLYWHEEL
20	FUSE 10 A
21	CDI CENTRAL IGNITION
22	BATTERY 12 V
23	ELECTRIC IGNITION RELAY 12V 70A
24	STARTER
25	H.T. COIL
26	REAR RIGHT FLASHING LIGHT
26A	FLASHING LAMP 12V 10W
27	TAIL LIGHT WITH LEDS
28	REAR LEFT FLASHING LIGHT
28A	FLASHING LAMP 12V 10W

COLOURS CODE	
YE	YELLOW
R	RED
B	BLACK
GR	GREEN
BR	BROWN
P	PINK
W	WHITE
VI	VIOLET
BL	BLUE
OR	ORANGE