

CONTENT

1. REGULAR INSPECTION

1-1 Delivery Introduction	3
1-2 Inspection Before Running	4
1-3 Regular Inspection	5
1-4 General Inspection	6
1-5 Notes for Inspection	6

2. MAINTENANCE INFORMATION

2-1 Specification Sheet	7
2-2 Maintenance Date	8
2-3 Special Tools	9
2-4 List of Grease & Oil Adopted	12
2-5 Circuit Drawings	13
2-6 Troubleshooting	20
2-7 Tighting Torque of Screws	21
2-8 Troubleshooting	23

3. DESCRIPTION OF PARTS AND COMPONENTS

3-1 Engine	23
3-2 Transmission Mechanism	35
3-3 Electric System	40
3-4 Body	44

4. DISASSEMBLY REPAIRMENT

4-1 Notice for Disassembly Repairment	48
4-2 Removal and Installation of Engine	49
4-3 Disassembly and Assembly of Engine	51
4-4 Removal and Assembly of Carburetor	62
4-5 Removal and Inspection of Electric Parts	64
4-6 Removal and Inspection of Body Parts	90
4-7 Built-In Braking System	95

CHAPTER I

REGULAR INSPECTION

1-1 Delivery Introduction

1-4 General Inspection

1-2 Inspection Before Running

1-5 Notes for Inspection

1-3 Regular Inspection

1-1 Delivery Introduction

To inform customers of correct methods to use:

To practically and correctly ride a scooter according to the Instruction of Manual and Maintenance Handbook. Customers should also try in person according to this manual.

1. Starting:

- A. Turn the power switch to "ON."
- B. Hold the front or rear brake and press the "START" button.
- C. If the scooter is not started, release the "START" button and try again after a few minutes. Each start should be less than five seconds to avoid battery consumption.

Note: This is an AUTO-CHOKE scooter, thus there is no choke lever.

The fuel is controlled only by throttle grip.

The accelerator has to return to its original place when the scooter is not in use.

- D. If the scooter can not be started by the "START" button, try the kick starter.

2. Fuel:

Inform customers to refill the fuel to no more than 80% of the tank capacity only.

1-1 Delivery Introduction

3 . Lubricant Adopted:

A. WARNING : TGB Supper Oil GA50400002 (OR 2 STROKE OIL in accordance with JASO FC) will be adopted as two-stroke engine oil. The engine oil must be refilled when the oil warning lamp lights, otherwise the engine will be burned-out due to insufficient lubrication.

B. TGB Gear Oil GA50400004 (OR SAE 85W-90) will be adopted as gear oil to be changed on a periodical basis. Gear oil and engine oil are different in their nature. Attention should be paid to avoid mistake when used.

4. Regular Inspection and Maintenance:

Inform customers of the importance of inspection before running and regular inspection.

A. Inspection Before Running: Riders should perform nspection by themselves before running.

B. Regular Inspection: Regular inspection should be performed after the first month and the sixth month and every six months afterwards.

5. Description of Warranty System:

Clearly identify the content of warranty in accordance with the warranty paper.

A. Content and term of warranty.

B. Maintenance items not guaranteed.

C. Items should be followed by customers.

Instruct customers to carry the OWNER'S Manual with them when they come for regular inspection and maintenance. It is because such inspection should be recorded onto the Manual.

1-2 Inspection Before Running

Items to be Inspected Before Running by Customers:

ITEM	CONTENT	GUIDELINE
1. Starter	Is the oil volume proper?	1. Check Oil Warning Lamp to see if the oil volume is proper?
2. Fuel	Is the fuel volume sufficient?	1. Check fuel volume to see if it is enough to the destination.
3. Lamp & Direction Indicator	Is the lamp condition well? Is there any dirt?	1. Check if the lighting condition of head lamp, tail lamp, licence lamp, brake lamp, direction indicator and other lamp is well. 2. Lamps should be kept clean and undamaged.
4. Back Mirror	Is the reflecting image well?	1. Look at the back mirror from the seat to check if the rear view is clear.
5. License Plate & Reflector	No dirt and damage should appear.	1. License plate should be installed, letters and numbers should be kept clear and clean. 2. Dirt and damage should not appear on the reflector.
6. Brake	Check the distance of brake handle lever and the brake effect.	1. Operate the handle lever slowly to the brake begin to effect in order to inspect the moving distance. 2. Test the brake with low speed running to see the brake effect of front and rear brakes.
7. Tire	1. Is the air pressure proper?	1. Check if the air pressure of tire is sufficient with a gauge or by sight.
	2. Groove should be deep enough.	1. Check if the groove of tires is enough.
	3. Unusual wear is not desired.	1. Check landing flat of tire to see if any unusual wear appears.
	4. Breaking and damage are not desired.	1. Check landing flat and side to see if any breaking or damage appear.
	5. Metal, stone and other articles are not desired.	1. Check if any cracking, stone or any other article sticks into the tire.

1-3 Regular Inspection

The chart below lists the recommended intervals for all the returned periodic service work necessarily to keep the motorcycle operating at peak performance and utmost efficiency.

Mileages are expressed in terms of kilometers and months.

These intervals judged by odometer reading or month whichever comes first.

Km	300 km	1000 km	2000 km	3000 km	4000 km	5000 km	6000 km	7000 km	8000 km	9000 km	10000 km	11000 km	12000 km
MONTHS	New Scooter period	1 months	2 months	3 months	4 months	5 months	6 months	7 months	8 months	9 months	10 months	11 months	12 months
ITEM													
Battery	I	I	I	I	I	I	I	I	I	I	I	I	I
Tire	I	I	I	I	I	I	I	I	I	I	I	I	I
Brake	I	I	I	I	I	I	I	I	I	I	I	I	I
Brake fluid	I			I			R			I			R
Bolts and nuts	I	I	I	I	I	I	I	I	I	I	I	I	I
Spark plug	I			I			I			I			I
Air cleaner				I			I			I			I
Final gear oil	R					R					R		
Cylinder head nut exhaust pipe bolts	I			I			I			I			I
Steering system	I						I						I
Suspension system	I			I			I			I			I
Engine idle rpm	I	I	I	I	I	I	I	I	I	I	I	I	I
Muffler	I					I							I
Oil pump	I			I		I				I			I
Fuel Filter						R							R

NOTE : I=Inspect and clean, adjust, lubricate or replace, if necessary.

R=Replace

T=Tighten

1-4 General Inspection General Inspection and Adjustment

* means adjustable.

Note: The ignition of this scooter by the use of crank-shaft which is 2 ignitions/revolution.
Special attention should be paid while setting the turning speed of Engine by Tachometer.

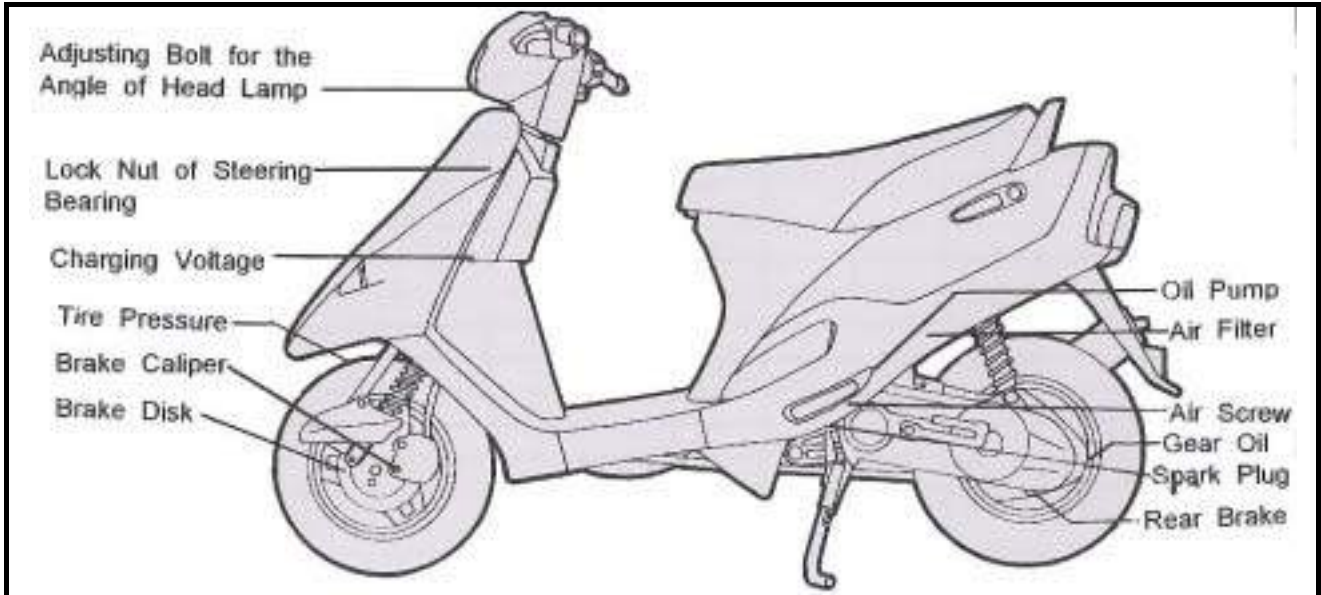

1-5 Notes for Inspection

ITEM	INSPECTION DETAILS
1	Be aware of smoke and fire while performing maintenance.
2	New Packing, Gasket, O Ring, locking pin should be used while assembling.
3	Only designated TGB oils should be used on spare parts.
4	Clean the vehicle before maintenance to avoid dirt or mud on disconnected parts.
5	The locking sequence of Bolt and Nut should be from inside to outside, or in diagonal step. Reverse the sequence to loose.
6	Special tools should be used when necessary.
7	Attention should be paid to avoid damage or loss of disconnected parts. Clean and grease properly before the assembly. No grease on Bolt's Thread.
8	Reconfirm each function after the assembly.
9	Special attention should be paid to the battery's electrolyte and brake oil which will stam clothes.

CHAPTER 2 MAINTENANCE INFORMATION

2-1 Specification Sheet

ITEM NO.	GA5	GF5	GI5	GE5	BH1	BR1	BK1	GF9	GI9	GE9	BH5	
Exhaust Volume	49.3 cc							82.4 cc				
Stroke	2T											
Overall Length mm	1700	1670	1800	1780	1695	1830	1875	1670	1800	1780	1695	
Overall Width mm	610	625	625	640	650	660	660	625	625	640	650	
Overall Height mm	1030	1020	1080	1090	1075	1170	1170	1020	1080	1090	1070	
Scooter Weight (Empty)	74 kg	78 kg	84 kg	82 kg	81 kg	92 kg	86 kg	81 kg	87 kg	95 kg	84 kg	
Tire(tubeless)	3.00-10 4PR	90/90-10	120/90-10 120/70-12	120/90-10 120/70-21	120/90-10 120/70-12	120/90-10 120/70-12 130/70-12 130/90-10	3.00-14	90/90-10	120/90-10 120/70-12	120/90-10 120/70-12	120/90-10 120/70-12	
Cylinder Type	Horizontally Placed											
Max Horsepower	5.0ps/7500rpm							6.5ps/7000rpm				
Gasoline	92 Unleaded Gasoline or Premium											
Lubrication Method	Oil Supplied Separately by Oil Pump											
Cooling Type for Engine	Air Cooled by Cooling Fan											
Ignition Method	C.D.I Ignition device w/o point.											
Rim comp Size	MT2.15x10	MT2.5x10	MT2.5x10 MT3.5x10 MT3.5x12	MT3.5x10 MT3.5x12	MT3.5x10 MT3.5x12	MT3.5x10 MT3.5x12	MT2.15x14	MT2.5x10	MT2.5x10 MT3.5x10 MT3.5x12	MT2.5x10 MT3.5x10 MT3.5x12	MT3.5x10 MT3.5x12	
Turn Signal	Flashing 80-85 Times/Minute.10W											
Spark Plug	BPR6HS,BPR7HS,BP6HS,BP7HS (NGK) Clearance: 0.6- 0.7mm							BP7HS -10(NGK) Clearance :0.9-1.0mm				
Battery	12V/4Ah											
flywheel magneto	Alternating Output:12V-50W											
Rectifier	AC 13V,DC14.5V											
Transmission	V-belt Continuous Variable Transmission											
Brake	Type A: Disk for Front and Drum for Rear Type B: Drum for both front and Rear											
Frame	Made of Steel Pipe and Plate by Pressing and Welding, With a Helmet Trunk.											
Head Lamp	35/35W OR 15WX2 OR 18/18WX2	15Wx2 OR 18/18X2	15Wx1 OR 30/30Wx2	15Wx2 OR 18/18Wx2	35/35W			35/35W OR 18/18Wx2	15Wx2 OR 18/18Wx2			
Tail Lamp	5W											
Front & Rear Direction Lamps	10W											
Brake Lamp	18W OR 21W					21W			18W OR 21W			
License Plate Lamp	5W											
Speedometer Lamp	1.7W x2											
High Beam Warning Light	1.7W x 1											
Oil warning Lamp	1.7W x 1											
Fuel Tank	3.7 L	5.2 L			5.1 L	6.8 L	5.1 L	5.3 L			5.1 L	

2.2 Maintenance Data

Cylinder +piston+Crank Shaft

ITEM	50 C.C.		90 C.C.	
	STANDARD	LIMIT	STANDARD	LIMIT
Cylinder Cover Flatness	0 0.02	0.1	0-0.02	0.1
Piston Outside Diameter (15mm above skirt)	40.935-40.95	40.89	49.94-49.955	49.90
Clearance Between Cylinder and Piston.	0.065-0.075	0.12	0.065-0.075	0.12
Bore of Piston Pin	10.002-10.01	10.04	12.004-12.015	12.05
Outside Diameter of Piston Pin	9.995-10.00	9.98	11.995-12.00	11.98
Bore of Small End of Con-Rod	14.003-14.011	14.05	14.996-15.007	15.05
Inside Diameter of Cylinder	41.005-41.020	41.07	5.005-50.020	50.07
Clearance at terminal of piston ring when assembled in Cylinder.	0.10-0.25	0.75 (1st&2nd Rings)	0.15-0.35	0.85
Radial Clearance of Big-End at Con-Rod	0.1-0.55	1.0	0.1-0.55	1.0
Runout of Crank Shaft	0-0.05	0.1	0-0.05	0.1

CVT

Free Length of Clutch Spring	98.1	96.9	110.0	111.8
Thickness of Clutch Lining	3.0	2.0	3.0	2.0
Bore of Clutch Housing	110-110.15	110.40	110-110.15	110.40

BRAKE

Bore of Brake Drum	110	110.7	110	110.7
Brake Lining O.D.	119.2	106	119.2	106
Thickness of Disc Brake Lining	4.5	2.0	4.5	2.0

WHEEL

Runout of the Inner Side at Wheel Rim		3		3
Wear Limit of Tire		0.8		0.8
Straightness of Front Wheel Shaft	0-0.15	0.25	0-0.15	0.25

Engine Oil

Capacity	0.8L		0.8L	
Residual Capacity when Light on	0.23L		0.23L	
Oil Used	TGB Super Engine Oil (JASO FC)		TGB Super Engine Oil (JASO FC)	
Oil Capacity of Gear Box	90c.c		90c.c	

Ignition

Lead		15°±3°BTDC /4000rpm		15°±3°BTDC /4000rpm
Spark Distance	6-8mm	5mm	6-8mm	5mm
Inner Electric Resistance at Spark Plug Cap	5-7.6k	3k	5-7.6k	3k

Battery

Specific Gravity of Electrolyte		1.32		1.32
Voltage for Charging		13-15V		13-15V
Fuse	10A(GA5) 7A (THE OTHERS)		7A	

Brake

Clearance of Front Brake Lever		20-30mm		20-30mm
Clearance of Rear Brake Lever		15-35mm		15-35mm

Tire Pressure

	GA5/GF5 GI5/ GE5 BH1	BK1 BR1		GF9 GI9/ GE9 BH5	BK5 BR5	
Front (kpa)	171	175		171	175	
Rear (kpa)	215	210		215	210	

2-3 Special Tools

GA5000051F04 / CVT-R Remover



To remove Driven Pulley Assy and Flywheel magneto.

GA5000051F12 / Bearing Remover



1. Taking out Right Hand Bearing of Drive Shaft
2. Applicable Scope $\varnothing 12$

GA5000051F05/
Crank Case & Shaft Remover



To divide Crank Case and to draw out Crank Shaft.

GA5000051F19 /
Bearing Remover



1. Taking out RH Crank Shaft Bearing of Crank case & Bearing of Rear Axle on left hand crank case.
2. Applicable Scope $\varnothing 20$

GA5000051F08/
Crank Shaft & Right HandCrank Case



To Draw the Crank Shaft into the Right HandCrank Case

Bearing Remover/GA5000051F20



1. Taking out LH Bearing of Drive Shaft on gear box cover.
2. Applicable Scope $\varnothing 17$

2-3 Special Tools

Bearing remover/GA5000051F21



1. Taking out LH Bearing of crank Shaft.
2. Applicable Scope $\varnothing 25$

GA5000051F17 / Bearing Installer



1. Left Hand Crank Shaft (Left Hand Bearing of Drive Shaft.)
2. Applicable Scope $\varnothing 17 \times \varnothing 47$

GA5000051F15/Bearing Installer



1. For Left Hand Crank Case
2. For Left Hand Crank Shaft Bearing
3. Applicable Scope $\varnothing 25 \times \varnothing 52$

GA5000051F18 / Bearing Installer



1. To press Right Hand Bearing of Drive Shaft
2. Applicable Scope $\varnothing 12 \times \varnothing 32$

Bearing Installer/GA5000051F16



1. For Left Hand Crank Case
2. For Right Hand Crank Shaft Bearing and Bearing of Rear Wheel
3. Applicable Scope $\varnothing 20 \times \varnothing 47$

/GA5000051F22 / Flywheel Magneto Remover



To remove Flywheel Magneto

2-3 Special Tools

Oil Seal Installer/GA5000051F30



1. Oil Seal for Right Hand Crank Case & Gear box cover
2. Applicable Scope $\varnothing 17 \times \varnothing 27$

GA5000051F33 / Oil Seal Installer



1. To install Oil Seal for Rear Axle and Crank Case
2. Applicable Scope $\varnothing 27 \times \varnothing 40$

GA5000051F31 / Oil Seal Installer



1. Left Hand Crank Case (Oil Seal for Engine oil pump gear)
2. Applicable Scope $\varnothing 24 \times \varnothing 43$

GA5000051F35 / CVT-F Remover



1. To remove The Driving Pulley of C.V.T
2. To remove Right Hand kickstarter

GA5000051F32 / Oil Seal Installer



1. Left Hand Crank Case (Oil Seal for left Hand Crank Shaft).
2. Applicable Scope $\varnothing 24 \times \varnothing 43$

GA504AL06D06 / Oil Seal Assembly Tools



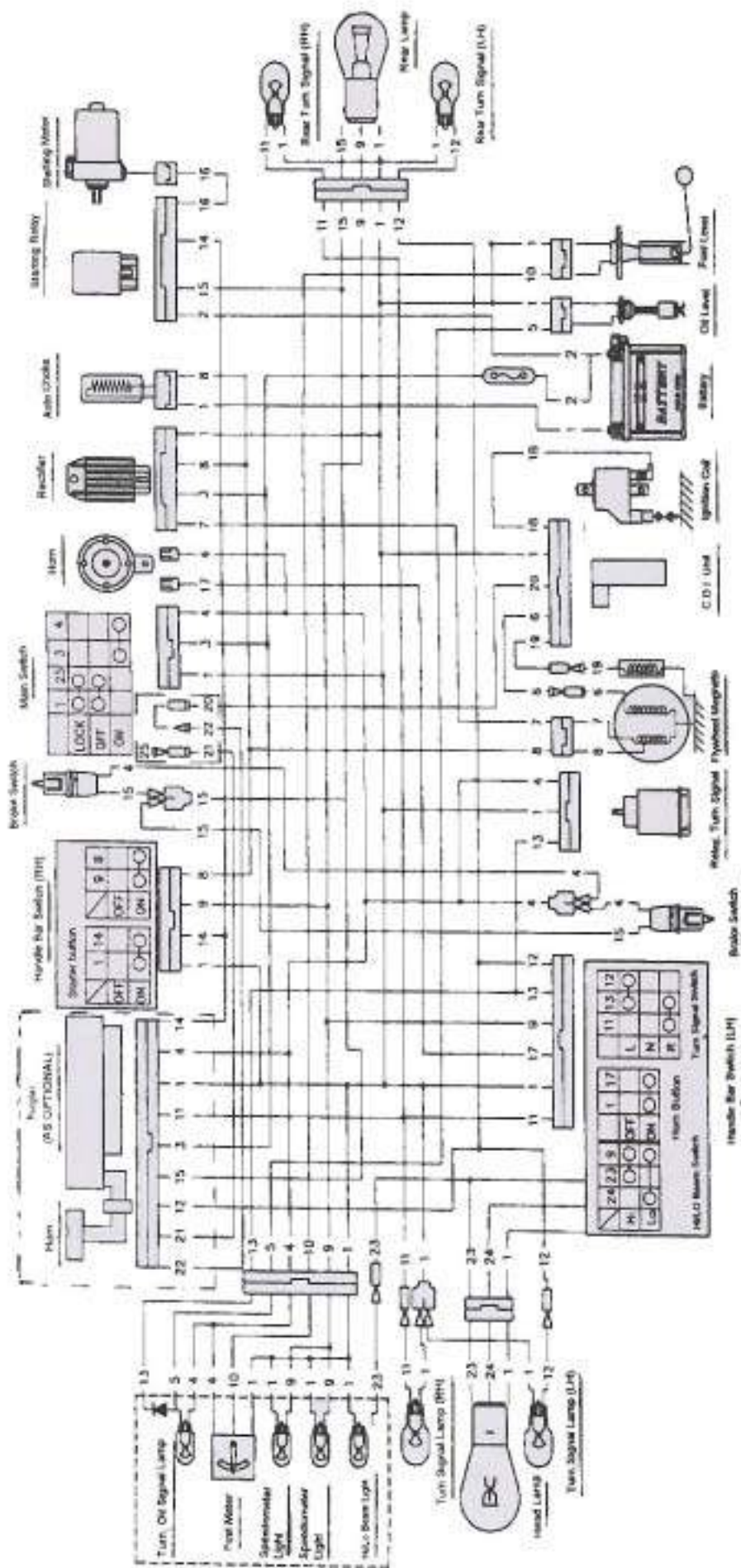

For Scooter After
 GAS RFCGAS5V120472 (Braut)
 RFCGAS5V120478 (The Others)

2-5 Circuit Drawing for GAS

20	Green/White	G/W
21	Orange/White	O/W
22	Purple/White	P/W
23	Yellow	Y
24	White	W

10	Yellow/Black	Y/B
11	Light Green	Lg
12	Black	B
13	Light Blue	Ll
14	Yellow/Green	Y/G
15	Black/White	B/W
16	Red/White	R/W
17	Green	G
18	White/Blue	W/L
19	Blue/Yellow	L/Y

Color	Code
1	Black/White
2	Red
3	Red
4	Orange
5	Blue/White
6	Black/Red
7	White/Red
8	Yellow/White
9	Gray

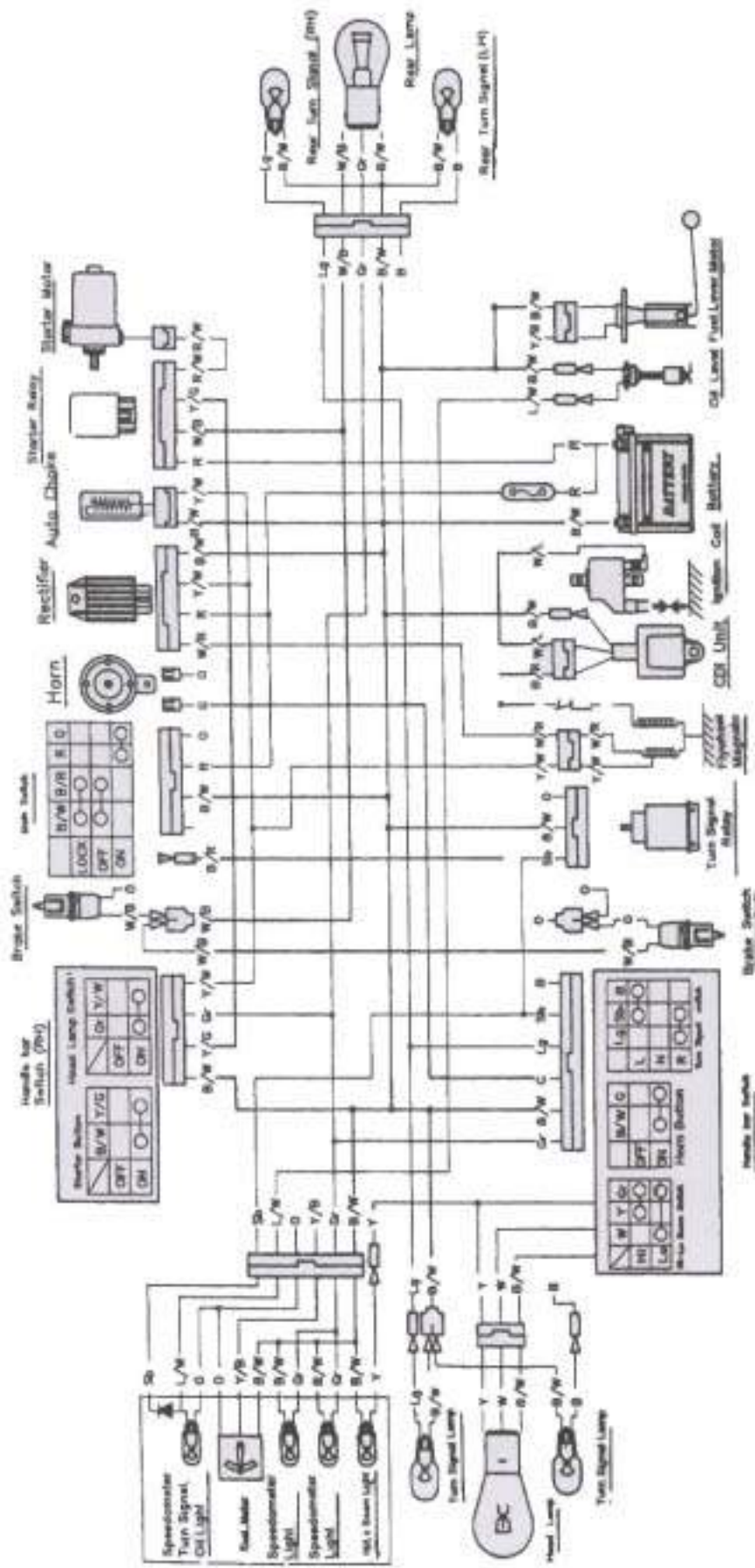

NO	Code	Color	NO	Code	Color
1	B	Black	10	Y/W	Yellow/White
2	O	Orange	11	Y/G	Yellow/Green
3	G	Green	12	W/L	White/Blue
4	Y	Yellow	13	W/R	White/Red
5	R	Red	14	W/B	White/Black
6	Lg	Light Green	15	B/W	Black/White
7	Sb	Light Blue	16	B/R	Black/Red
8	Gr	Grey	17	R/W	Red/White
9	Y/B	Yellow/Black	18	L/W	Blue/White

For Scooter Before
GA5 [RFCPALL48V1004721 (Brazil)]
 [RFCGASGASVY120475 (The Others)]

2-5 Circuit Drawing for GA5

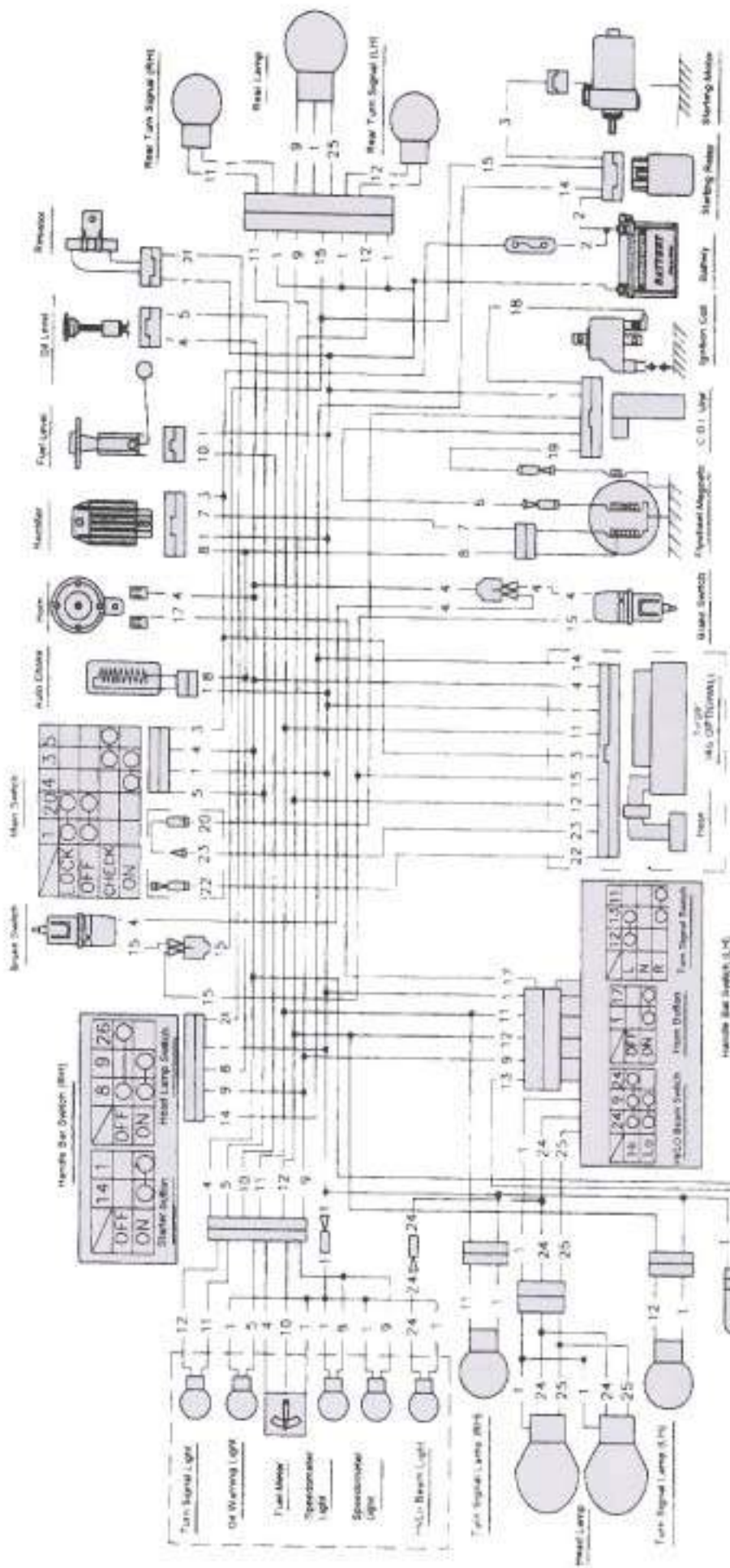

For Scooter After

GF5	RFCERGN46V1003372 (Brazil)
GF5	RFCGF5GASVY120996 (The others)
GF9	RFCGF9GASVY000051
GI5	RFCGI5S46V1002462 (Brazil)
GI9	RFCGI9S46VY922771 (The Others)
GI9	RFCGI9S80V1001948 (Brazil)
GI9	RFCGI9S80VY120996 (The Others)

2-5 Circuit Drawing for GF5/GF9/GI5/GI9

20	Black/White	B/W
21	Yellow/Black	Y/B
22	Orange/White	O/W
23	Purple/White	P/W
24	Yellow	Y
25	Green	G

10	Green/White	G/W
11	Deep Green	Dg
12	Chocolate	Ch
13	Brown/White	B/W
14	Blue/White	L/W
15	Green/Yellow	G/Y
16	Red/White	R/W
17	Pink	P
18	White/Blue	W/B
19	Blue/Yellow	L/Y

Color	Code
1	Black
2	Red
3	Red
4	Brown
5	Gray
6	Black/Red
7	White/Red
8	Yellow/Red
9	Blue

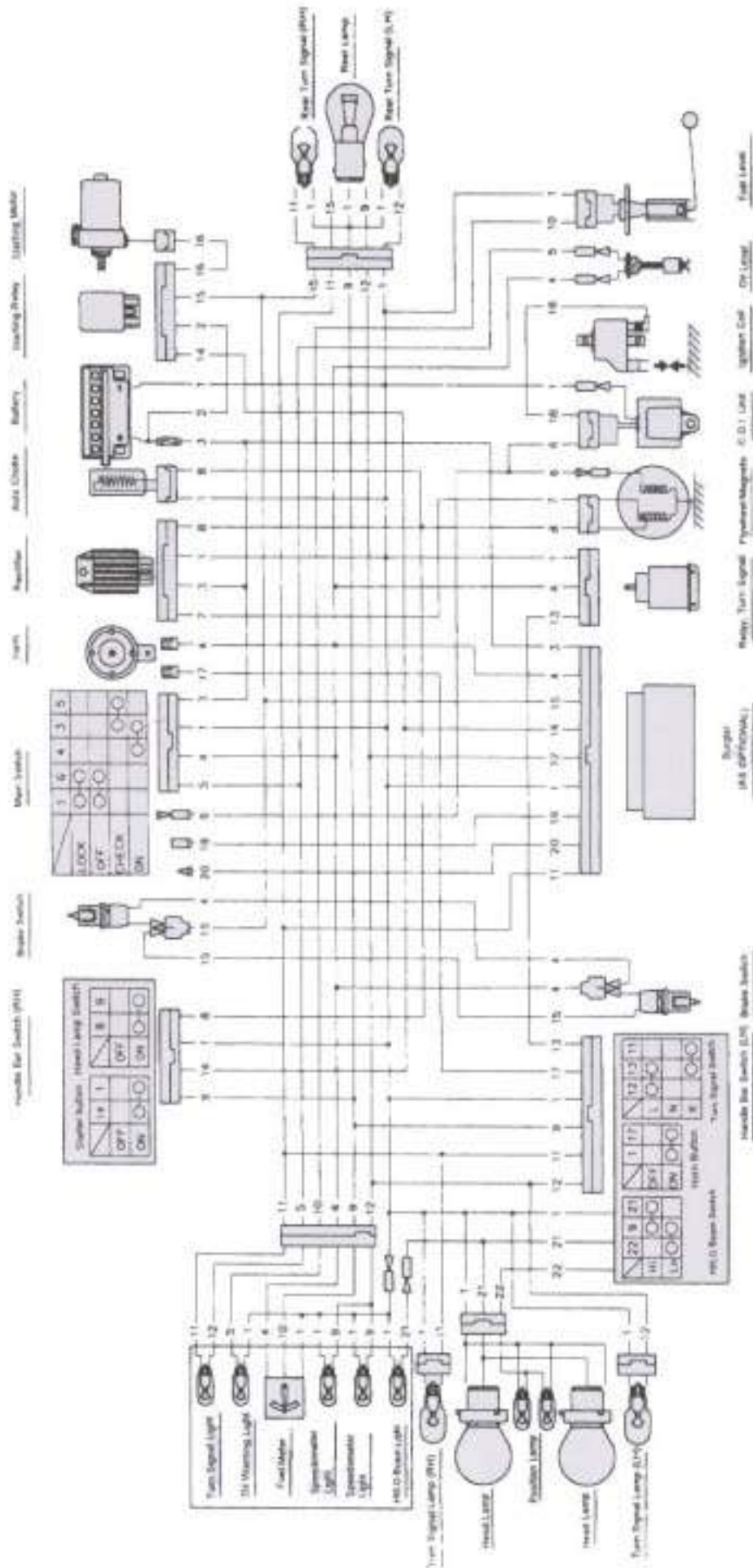

Code	Color
1	Black
2	Red
3	Red
4	Brown
5	Gray
6	Black/Red
7	White/Red
8	Yellow/Red
9	Blue
10	Green/White
11	Deep Green
12	Chocolate
13	Brown/White
14	Blue/White
15	Green/Yellow
16	Red/White
17	Pink
18	White/Blue
19	Orange/White
20	Purple/White
21	Yellow
22	Green

Code	Color
1	Black
2	Red
3	Red
4	Brown
5	Gray
6	Black/Red
7	White/Red
8	Yellow/Red
9	Blue
10	Green/White
11	Deep Green
12	Chocolate
13	Brown/White
14	Blue/White
15	Green/Yellow
16	Red/White
17	Pink
18	White/Blue
19	Orange/White
20	Purple/White
21	Yellow
22	Green

Code	Color
1	Black
2	Red
3	Red
4	Brown
5	Gray
6	Black/Red
7	White/Red
8	Yellow/Red
9	Blue
10	Green/White
11	Deep Green
12	Chocolate
13	Brown/White
14	Blue/White
15	Green/Yellow
16	Red/White
17	Pink
18	White/Blue
19	Orange/White
20	Purple/White
21	Yellow
22	Green

For Scooter Before	Part No.
GF5	RFCERGI48V1003371 (Brazil)
GF9	RFCGF5GA5VY120995 (The Others)
GI5	RFCGFRGA9VY000050
GI9	RFCARRS49V1002451 (Brazil)
	RFCGEGH45V522770 (The Others)
	RFCARRS90V1001947 (Brazil)
	RFCGHBG48V120995 (The Others)

2-5 Circuit Drawing for GF5/GF9/GI5/GI9

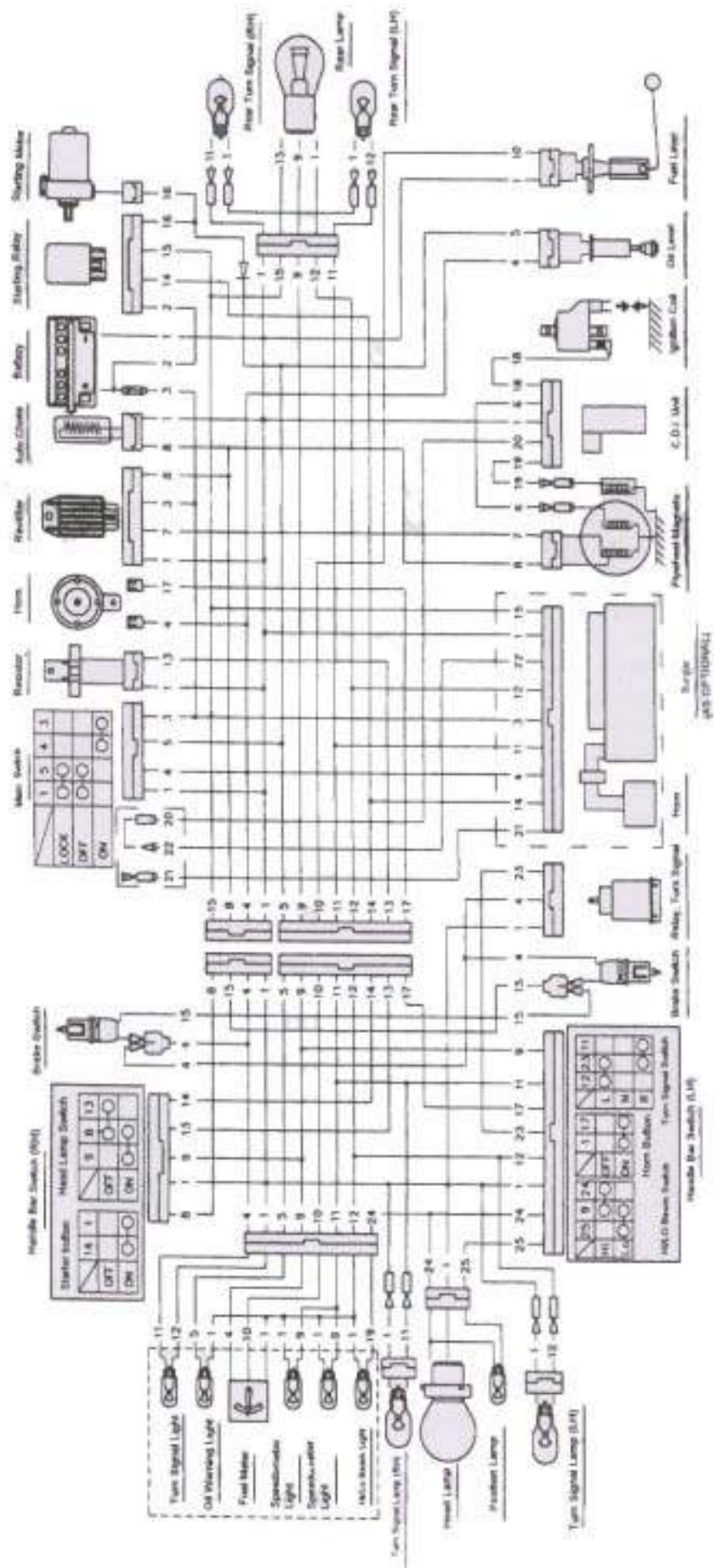

2-5 Circuit Drawing for GE

20	Black/White	B/W
21	Yellow/Black	Y/B
22	Orange/White	O/W
23	Purple/White	P/W
24	Yellow	Y
25	Green	G

10	Green/White	G/W
11	Deep Green	Dg
12	Chocolate	Ch
13	Brown/White	B/W
14	Blue/White	L/W
15	Green/Yellow	G/Y
16	Red/White	R/W
17	Pink	P
18	White/Blue	W/B
19	Blue/Yellow	L/Y

Color	Code
1	Black
2	Red
3	Red
4	Brown
5	Gray
6	Black/Red
7	White/Red
8	Yellow/Red
9	Blue

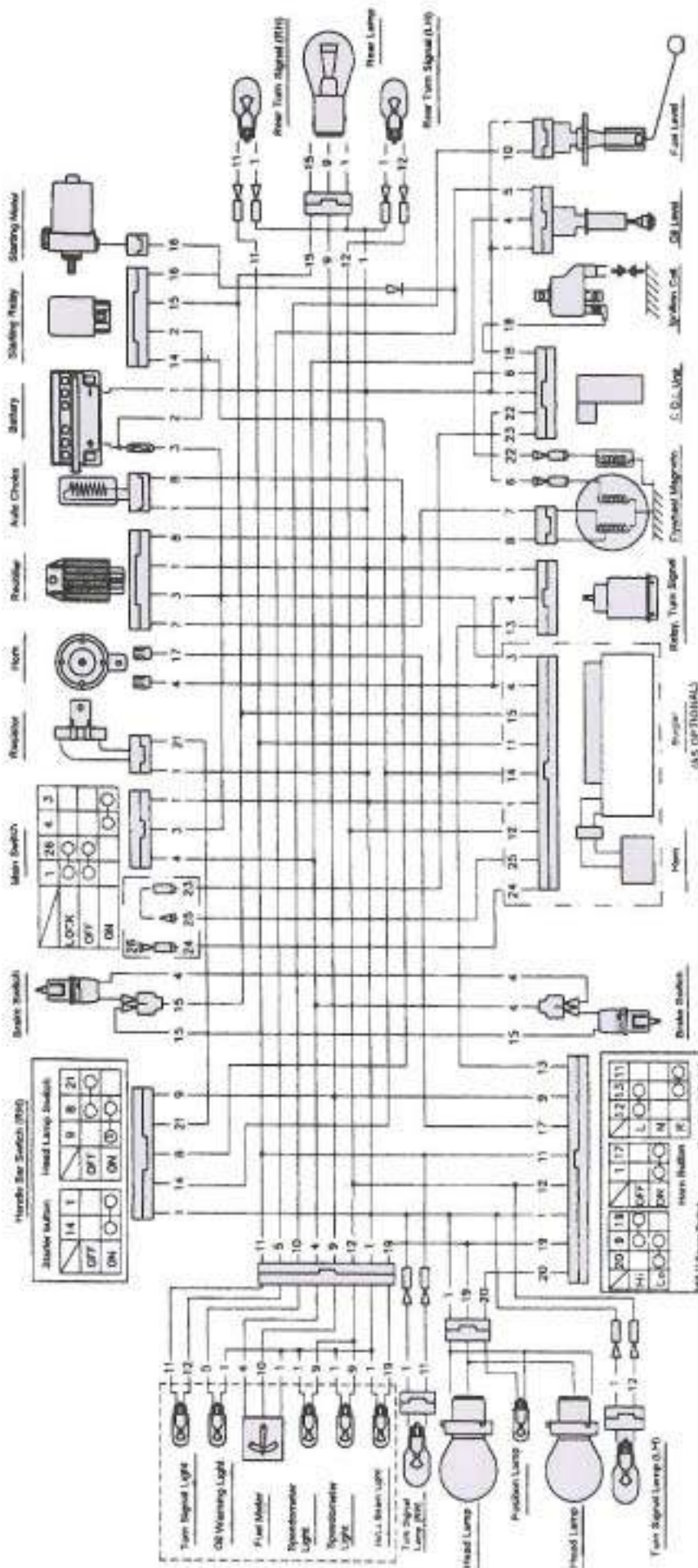

Color	Code
1 Black	B
2 Red	R
3 Red/White	R/W
4 Brown	Br
5 Gray	Gy
6 Black/Red	B/R
7 White/Red	W/R
8 Yellow/Red	Y/R
9 Blue	L

Handle Bar Switch (H)	Turn Signal Switch
10 Green/White	GW
11 Deep Green	Dg
12 Chocolate	Ch
13 Brown/White	Br/W
14 Blue/White	LW
15 Green/Yellow	G/Y
16 Red/White	RW
17 Pink	P
18 White/Blue	W/L
19 Yellow	Y

Brake Switch	Head Lamp Switch
20 Green	G
21 Yellow/Black	Y/B
22 Blue/Yellow	L/Y
23 Black/White	B/W
24 Orange/White	O/W
25 Purple/White	P/W

2-5 Circuit Drawing for BH

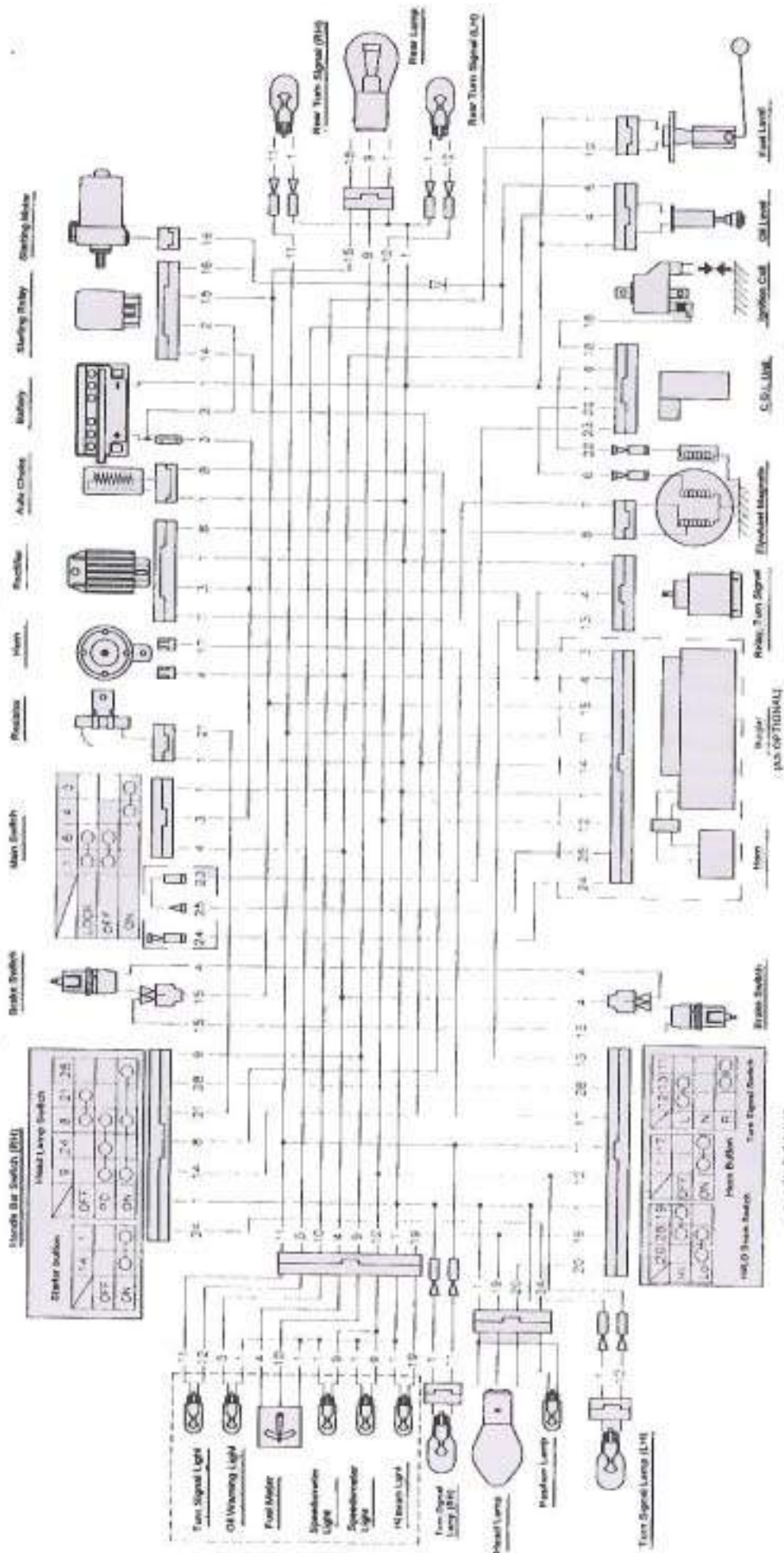

CODE	COLOR
19	VELLOW
20	GREEN
21	VELLOW/BLACK
22	BLUE/YELLOW
23	BLACK/WHITE
24	SEV BLUE
25	GRANOE/WHITE
26	PURPLE/WHITE
28	BLUE/BLACK

CODE	COLOR
10	GREEN/WHITE
11	DEEP GREEN
12	CHOCOLATE
13	BROWN/WHITE
14	BLUE/WHITE
14	GREEN/YELLOW
16	RED/WHITE
17	PINK
18	WHITE/BLUE

CODE	COLOR
1	BLACK
2	RED
3	RED/WHITE
4	BROWN
5	GRAY
6	BLACK/RED
7	WHITE/RED
8	VELLOW/RED
9	BLUE

2-5 Circuit Drawing for BK1/BR1

2-4 List of Grease & Oil Adopted:

<p>GA55100001 TGB Supper Grease No.0 Apply in Oil Seal.</p>	<p>GA50400003 Supper Grease No.3 Apply in Axle Shaft, inside of Oil Seal.</p>
<p>GA50400001 1104 Sealing Three- Bond Apply on Right Hand Crank Surface.</p>	<p>GA50400004 TGB Gear Oil 85w/90 Transmission Gear Oil for Scooters.</p>
<p>GA50400002 TGB Supper Oil (JASO FC) Apply in oil tank</p>	<p>GA55100002 Three-Bond 1322 Under M10 Screw (For medium fixing) for Flywheel Magneto.</p>
<p>GA50400005 TGB Supper Grease No. 1 Apply in Oil Seal.</p>	<p>GA55100003 DOT-3 Brake Oil For Brake.</p>
<p>GA50400006 TGB Supper Grease No.2 Apply in Kick Starter.</p>	<p>GA50400008 TGB Supper Grease No.4 For Movable Drive Face Comp.</p>
<p>GA50400017 Cemedine 575 Apply in Handle Grip</p>	

2.6 Troubleshooting

Complaint	Possible Reason	Remedy
No action for starter motor	<ol style="list-style-type: none"> 1. Fuse breaks. 2. No power in battery. 3. Defective action of brake switch. 4 Short circuit of starter relay. 	Replace Charging Replace Replace
No sparking or poor sparking	<ol style="list-style-type: none"> 1. Defective spark plug. 2. Defective CDI & ignition coil unit. 3. Defective magneto stator coil. 4. Loose connection of lead wire. 	Replace Replace Replace Connect
Unable or Difficult to start	<p>Plug not sparking</p> <ol style="list-style-type: none"> 1. Damaged spark plug or spark plug cap. 2. Dirty or wet spark plug. 3. Defective CDI & ignition coil unit or stator coil. 4. Open or short in high-tension cord. 5. Defective ignition switch. <p>No fuel reaching the carburetor</p> <ol style="list-style-type: none"> 1. No gasoline in fuel tank. 2. Clogged hole in the fuel tank cap. 3. Clogged or defective fuel cock. 4. Clogged fuel hose or defective vacuum hose. <p>Compression too low</p> <ol style="list-style-type: none"> 1. Excessively worn cylinder or piston rings. 2. Spark plug too loose. 3. Broken, cracked or otherwise failed piston. 	Replace Clean & dry Replace Replace Replace Replace Clean Clean or replace Clean or replace Replace Tighten Replace
Noisy engine	<ol style="list-style-type: none"> 1. Piston or cylinder worn down. 2. Combustion chamber fouled with carbon. 3. Piston pin, bearing or piston pin worn. 4. Worn or burnt crankshaft bearings. 	Replace Clean Replace Replace
Engine idles poorly	<ol style="list-style-type: none"> 1. Stiff piston ring in place. 2. Excessively worn cylinder or piston rings. 3. Gas leaks from crankshaft oil seal. 4. Defective CDI & ignition coil unit. 5. Clogged jets in carburetor. 	Replace Replace Replace Replace Clean or adjust

2-7 Screw Torque

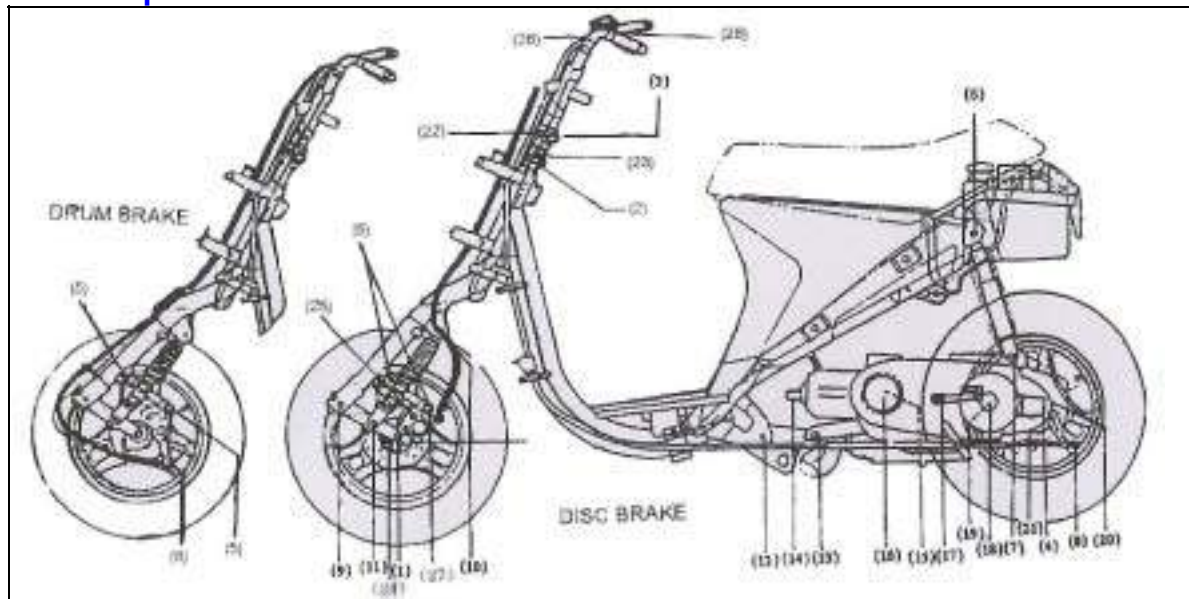

Screw Torque of Body for GA5/GF5/GF9

Item	Locking Location	Thread	pcs	Torque
1	Front Axle Nut	10	1	330-520kg.cm
2	Steering Stem Lock Nut	25.4	1	600-650kg.cm
3	Handle-bar Clamp Nut	10	1	550-600kg.cm
4	Rear Axle Nut	16	1	600-900kg.cm
5	Torque Link Nut	8	2	180-300kg.cm
6	Rear Shock Absorber Upper Bolt	8	1	200-300kg.cm
7	Rear Shock Absorber Lower Bolt	8	1	200-300kg.cm
8	Brake Cam Nut	6	2	60-90kg.cm
9	Front Suspension Arm point Nut	10	2	240-360kg.cm
10	Front Shock Absorber Upper Bolt	8	2	100-150kg.cm
11	Front Shock Absorber Lower Bolt	8	2	100-150kg.cm
12	Crank Case Bracket Nut	10	1	480-720kg.cm
13	Engine Mount-Nut	10	1	400-600kg.cm
22	Handle- bar Screw	8	1	250kg.cm
23	Bearing Lock Nut	25.4	1	200kg.cm
24	Brake Disc Nut	10	3	180-280kg.cm
25	Caliper Bolt	8	2	210-250kg.cm
26	Brake Hose Bolt	10	2	250-320kg.cm
27	Brake Pad Brkt Bolt	8	1	180-300kg.cm
28	Master Cylinder Bolt	6	2	200kg.cm

Screw Torque of Engine For All model

Item	Locking Location	Thread	Torque kg.cm
14	Spark Plug		250-300kg.cm
15	Flywheel Magneto	10	350-450kg.cm
16	Nut of Kick Starter, RH	12	400-600kg.cm
17	Bolt of Kick Starter	6	80-120kg.cm
18	Nut of Driven Pulley Assy	28	400-600kg.cm
19	Nut of Clutch Housing	10	400-600kg.cm
20	Bolt of Fuel Inlet	8	90-150kg.cm
21	Screw of Fuel Outlet	6	40-70kg.cm

2-7 Screw Torque

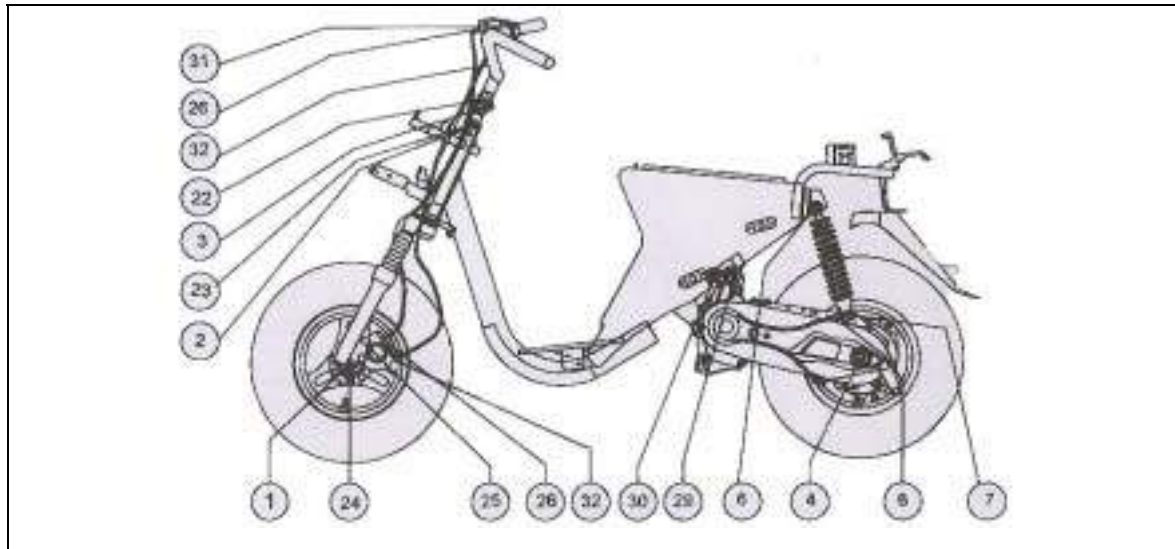

Screw Torque of Body for GI5/GI9//GE5/GE9/BH1/BH5

Item	Locking Location	Thread	pcs	Torque
1	Front Axle Nut	12	1	550-600kg.cm
2	Steering Stem Lock Nut	25.4	1	600-650kg.cm
3	Handle Bar Lock Screw	10	1	550-600kg.cm
4	Rear Axle Nut	16	1	600-900kg.cm
6	Rear Shock Absorber Upper Bolt	10	1	200-300kg.cm
7	Rear Shock Absorber Lower Bolt	10	1	200-300kg.cm
8	Rear Brake	6	1	60-90kg.cm
22	Handle- bar Screw	8	1	250kg.cm
23	Bearing Lock Nut	25.4	1	200kg.cm
24	Brake Disc Nut	10	3	180-280kg.cm
25	Caliper Bolt	8	2	210-250kg.cm
26	Brake Hose Bolt	10	2	250-320kg.cm
29	Engine Hanger Nut	12	1	550-600kg.cm
30	Frame Engine Nut	10	2	550-600kg.cm
31	Master Cylinder Bolt	6	2	200kg.cm
32	Speedometer Cable Nut		2	60kg.cm

General Torque

Thread	General Bolt kg.cm	Heavy Duty Bolt kg.cm
4	10-20	15-30
5	20-40	30-60
8	100-160	80-120
10	220-350	300-400
12	350-550	500-600

2-8 Troubleshooting

2-8-1 Troubleshooting for failure in starting the engine

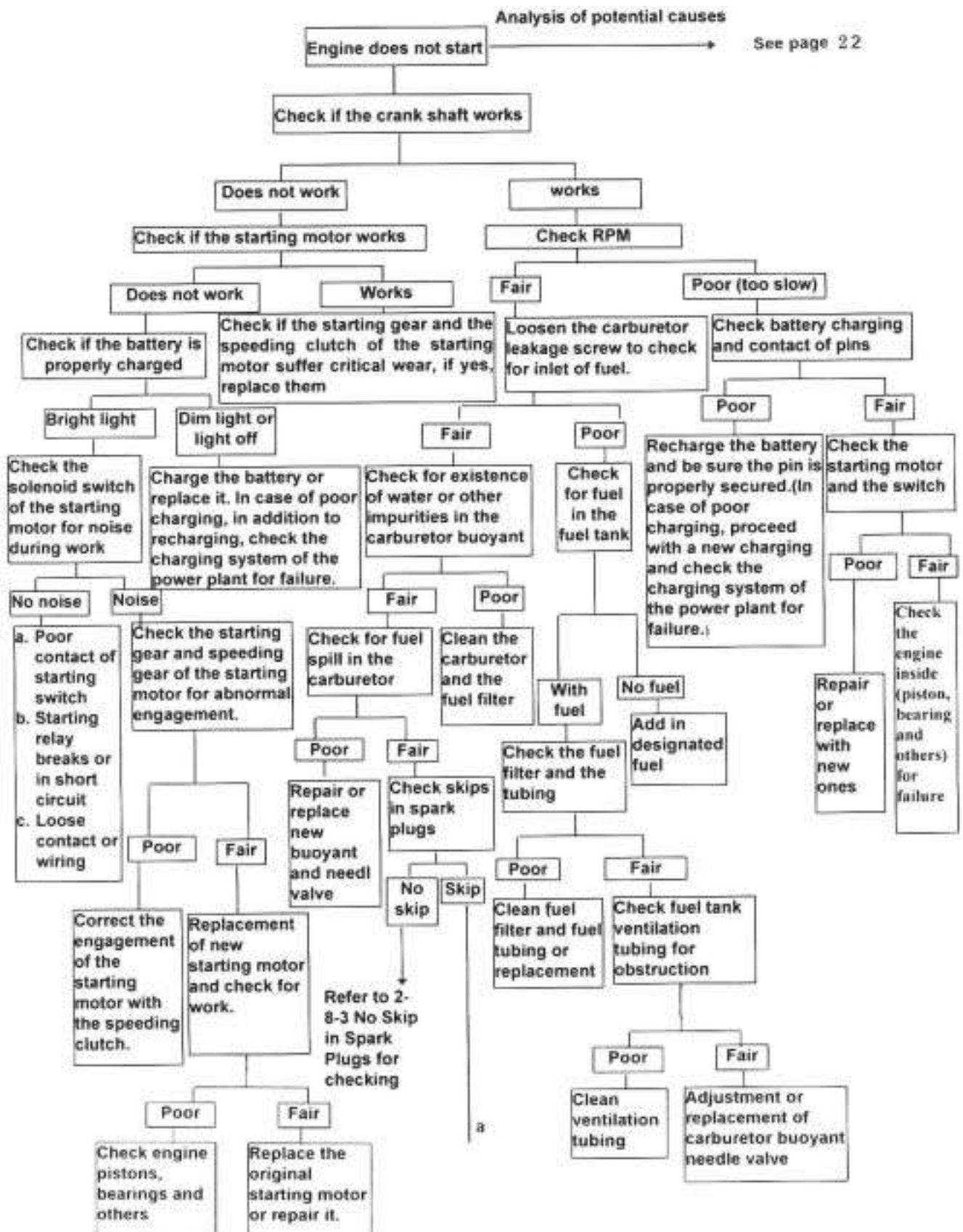

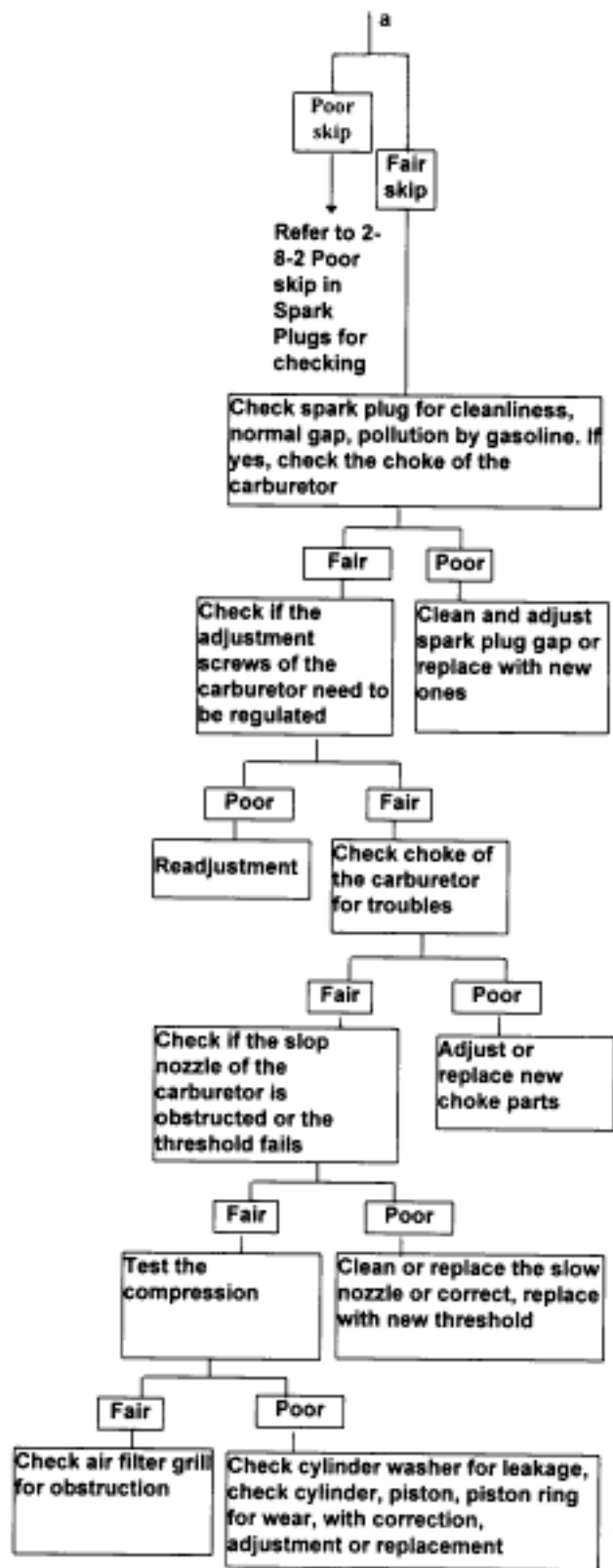

Check item :

No fuel

Dirty fuel filter

Obstructed ventilation tubing of the fuel tank

Poor carburetor buoyant needle valve

Carburetor buoyant with impurities

Poor carburetor buoyant

No skip in spark plugs

Poor skip in spark plugs

Dirty spark plugs

Incorrect spark plugs gap

Dirty and wet spark plugs

Loose adjustment screws in the carburetor

Carburetor choke

Obstructed carburetor slow nozzle

Ailing carburetor threshold

Obstructed air filter grill

Leakage in cylinder washer

Seriously damaged cylinder, piston

Dead battery

Poor contact of battery pin and conductors

Starting switch with poor or failure

Starting relay with broken wire or short circuit

Loose contact and wiring

Starting gear and speeding clutch gear seriously worn

Starting gear and speeding clutch gear in poor engagement

Poor starting motor

2-8-2 Troubleshooting for poor skip of spark plugs

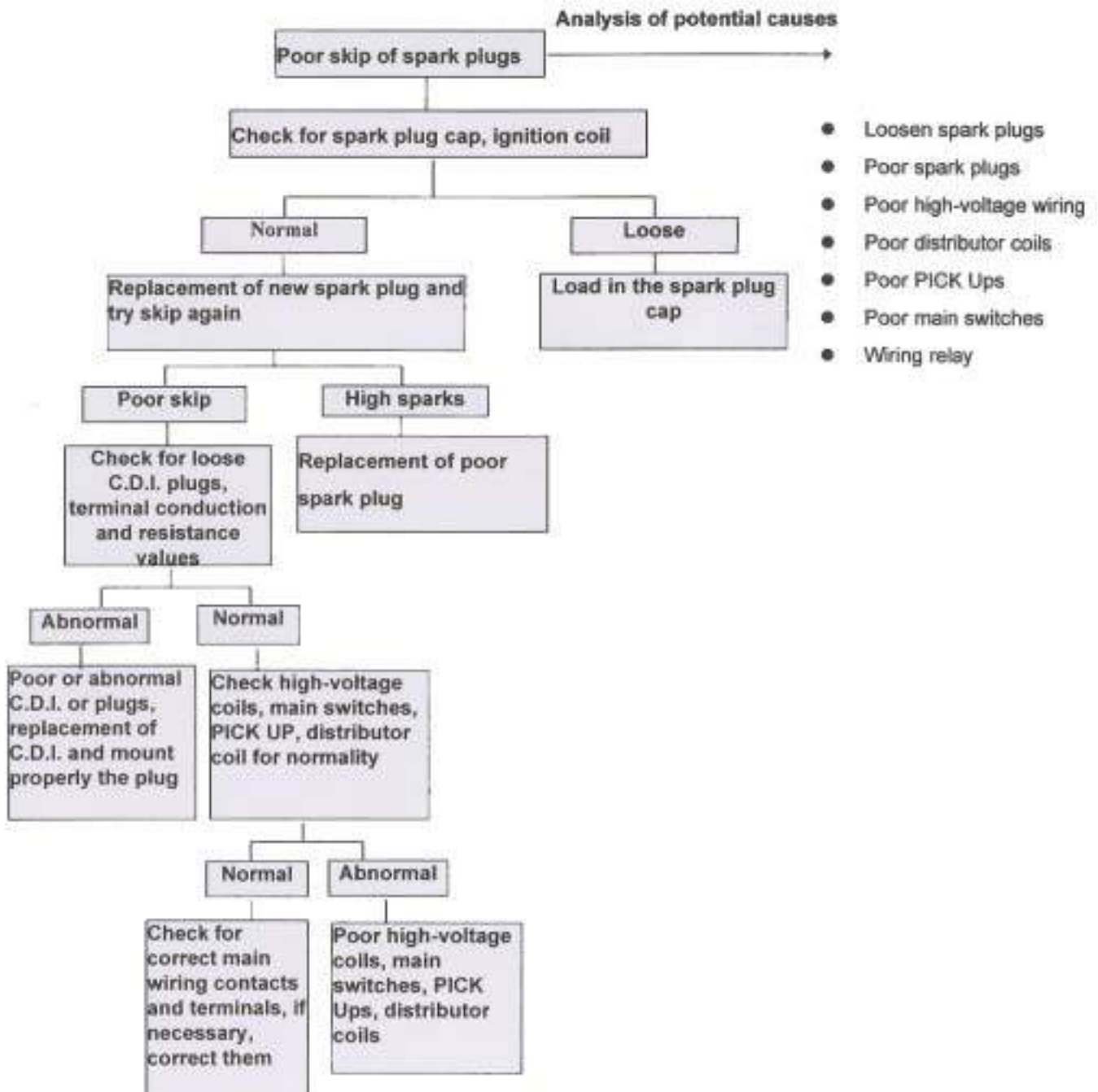

2-8-3 Troubleshooting for no-skip of spark plugs

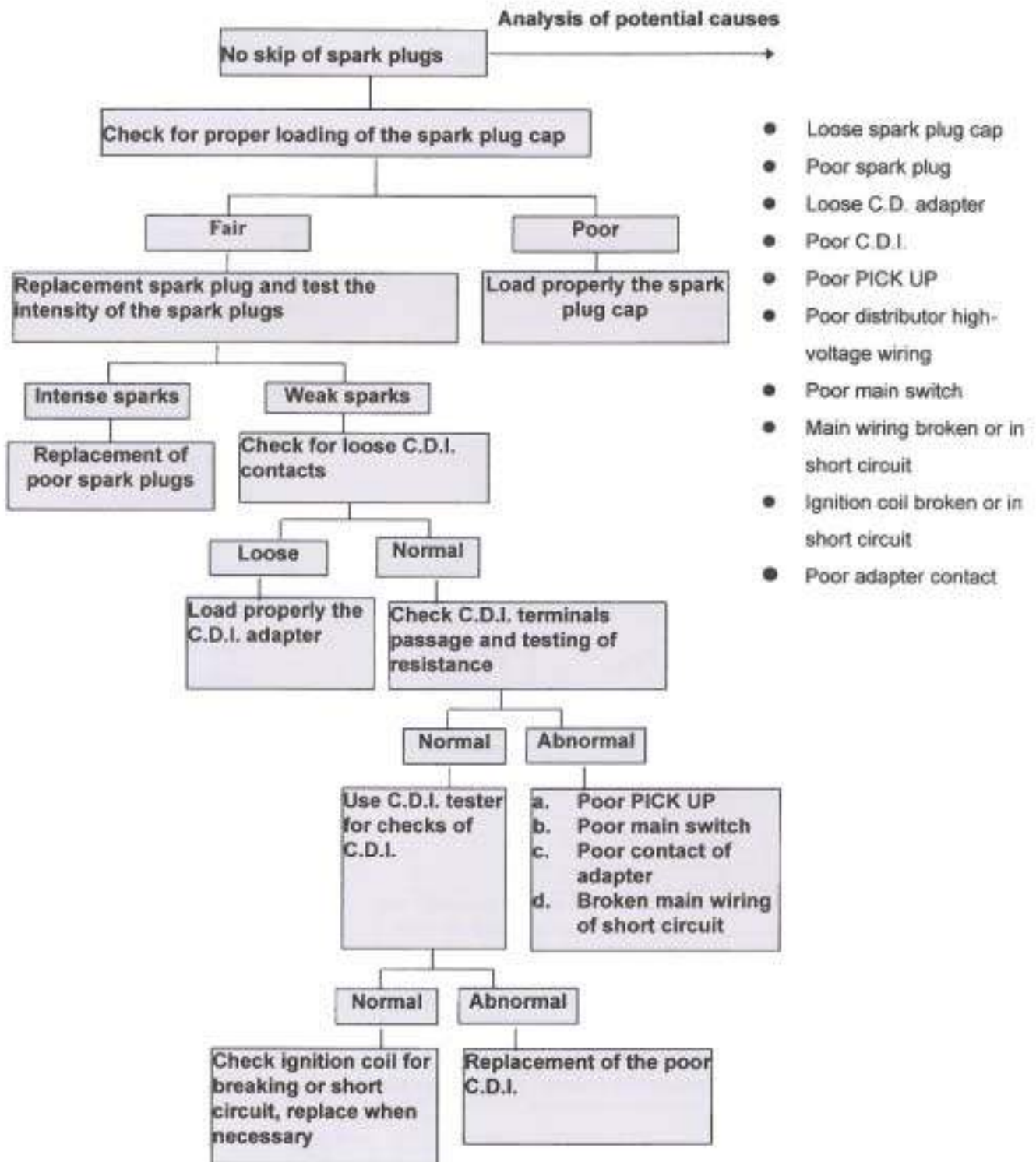

2-8-4 Troubleshooting for slow run (troubled engine)

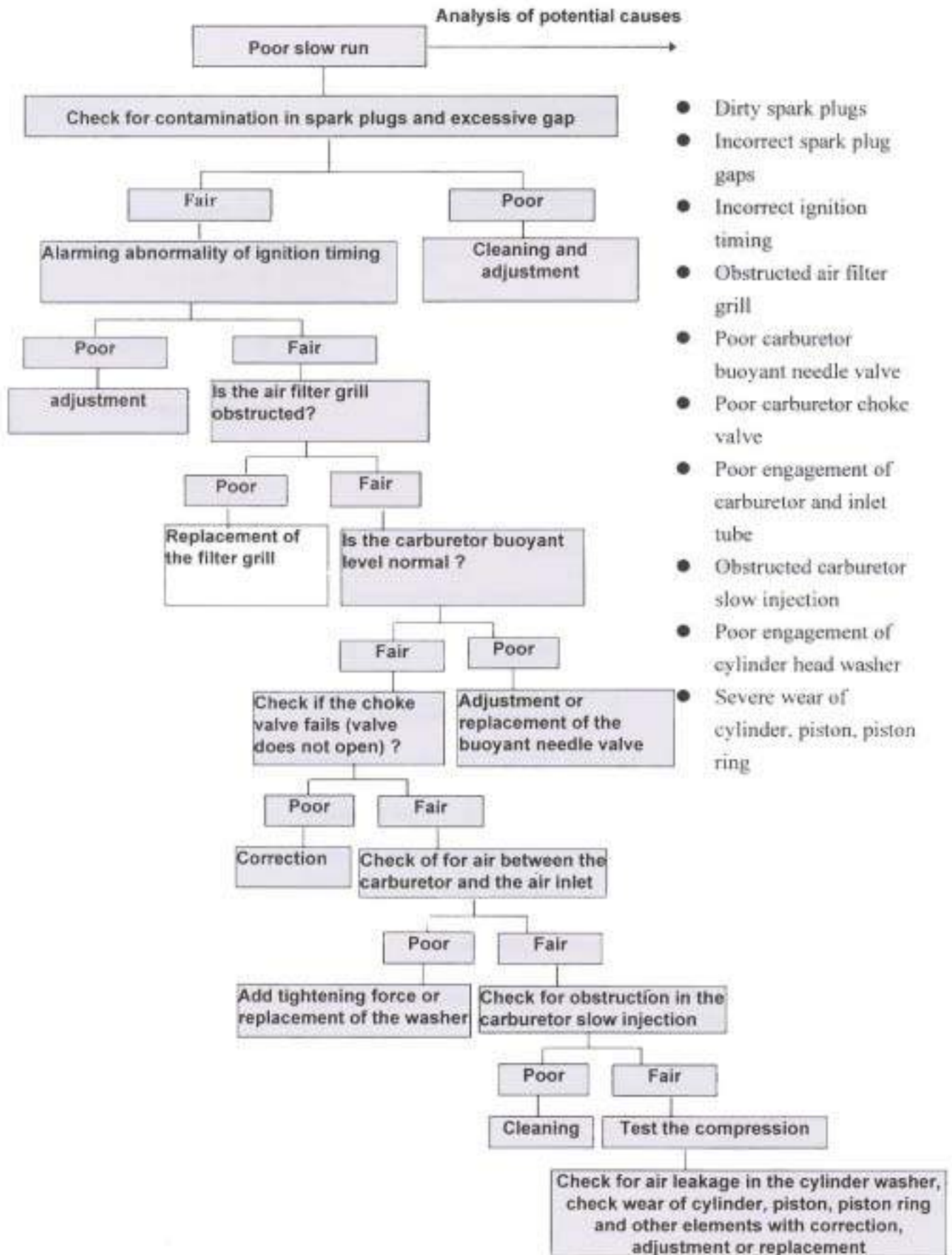

2-8-5 Poor acceleration and horse power

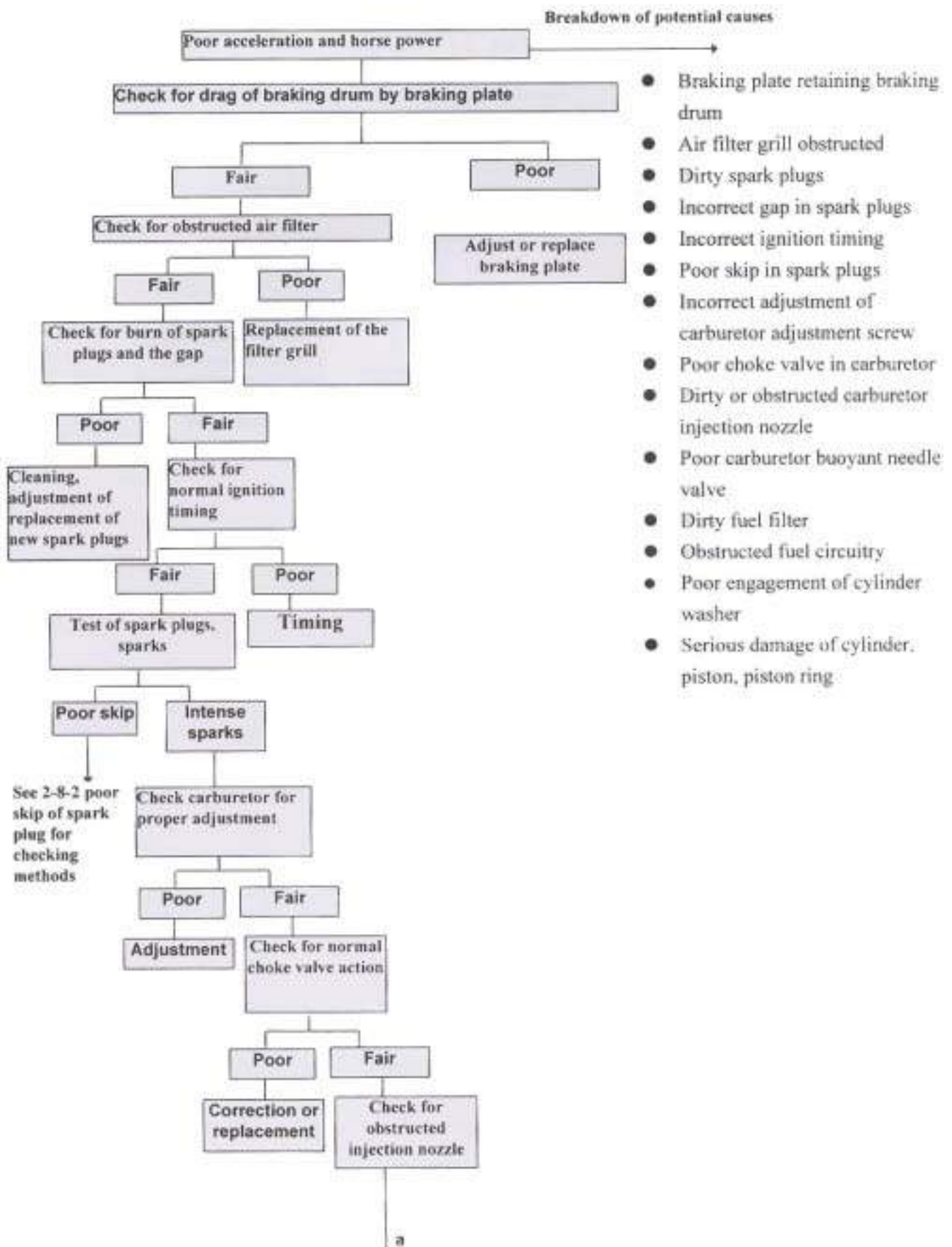

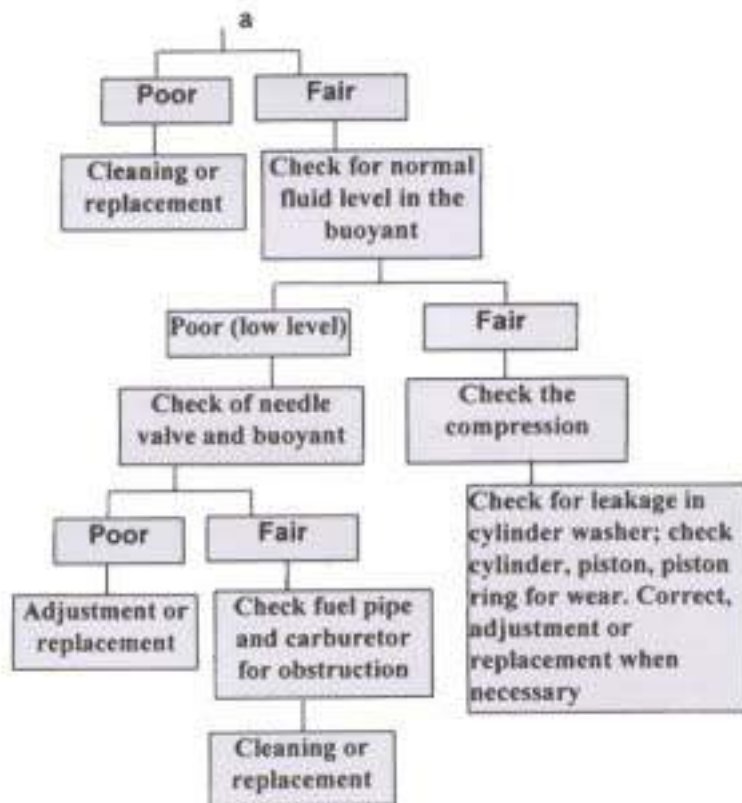

CHAPTER 3 DESCRIPTION OF COMPONENTS AND ASSEMBLY

3-1 ENGINE

3-1-1 Combustion & Air In-Take & Exhaust System

3-1-2 Carburetor

3-1-3 Lubrication & Cooling System

3-2 TRANSMISSION MECHANISM

3-2-1 Power Transmission

3-2-2 Continuous Variable Transmission

3-2-3 Reducing Gear

3-2-4 Kick Starter

3-3 ELECTRIC SYSTEM

3-3-1 Ignition & Charging Device

3.3-2 Lamps

3-4 BODY

3-4-1 Frame, Fuel and Oil System

3-4-2 Compartment and Seat

3-4-3 Front & Rear Suspension System

3-4-4 Brake System

3-1 ENGINE

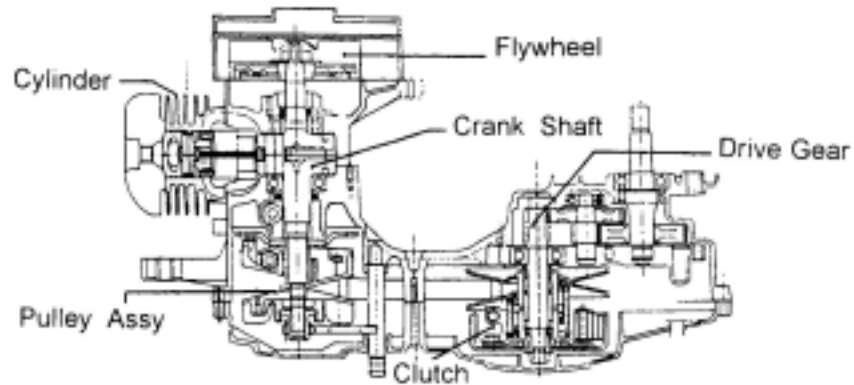

3-1-1 Combustion & Air Inlet-Outlet System

I. Combustion System

- A. Cylinder Head: made of aluminum alloy. the combustion chamber.
- B. Spark Plug: NGK BP6HS, BP7HS, BP7HS-10, BPR6HS, BPR7HS, differ with each Type.
- C. Cylinder: made of cast iron, with one exhaust port and five scavenging ports.
- D. Piston: made of high silicon aluminum alloy.
- E. Piston Ring: including first and second rings, and the expander ring installed in the inner side of 2nd ring. (FOR 50C.C.) Two Piston Rings (FOR 90C.C.)
- F. Con-Rod: with needle bearing on both big end and small end.
- G. Bearing: with a ball bearing on each left and right rand side.

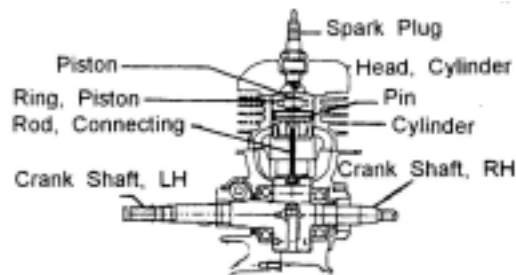

2. Air In-Take & Exhaust System

- A. Air Filter: with pre-filter and filter to eliminate dust and dirt.
- B. Carburetor: VM13 Auto-Choke type (or PHVA 10, PHVA I2, PHVA16 etc.)
- C. Reed Valve: with steel single reed and locked into the inner side of air in- take pipe.
- D. Crank Case: made of aluminum alloy.
- E. Muffler: with sound-absorbed fiber glass and expansion chamber.

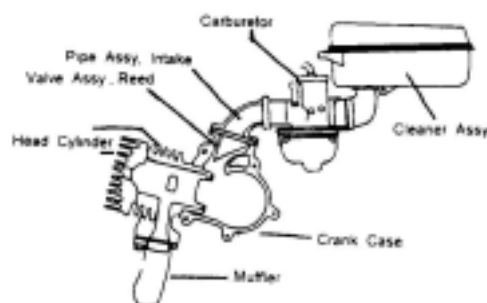

3-1-2 Carburetor

I. idle Jet :

When scooter idling, gasoline will pass through idle jet and mix with air and go into the crank case. When the throttle handle opens, the piston valve and needle jet are elevated to let gasoline pass through the main jet and mix with air and go into the crank case

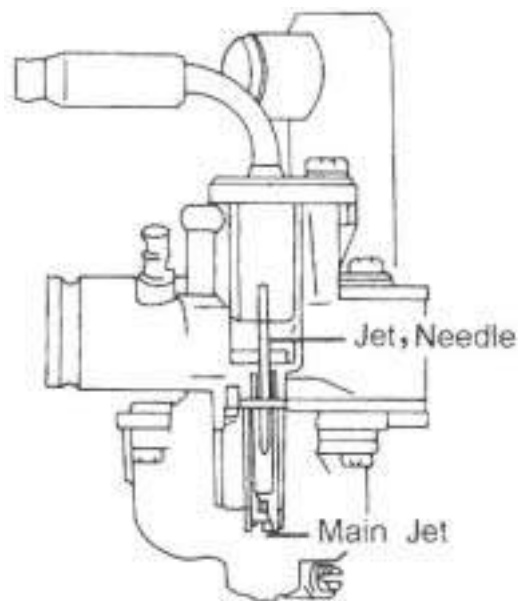

2 . Auto-Choke:

The body of Carburetor is equipped with PTC Heater to-start the Choke Plunger. Part of the electricity made by Fly-wheel Magneto is used on PTC Heater, which heats the Ceramic plate. The heat then expands the Thermo- Wax to start the Starter-Plunger to activate the Auto-Choke in warm condition. The path is in closed condition then.

In cold condition, the Thermo-Wax will contract according to the temperature, so the Choke-Plunger is in open condition.

3-1-3 Lubrication & Cooling System

1. Lubrication of Engine :

A. The Pump Gear is driven by the Screw Crank Shaft to rotate the Plunger valve of oil-Pump and send the lubricating oil into the Crank to completely mix with the carburetted air and then go into the Combustion Chamber.

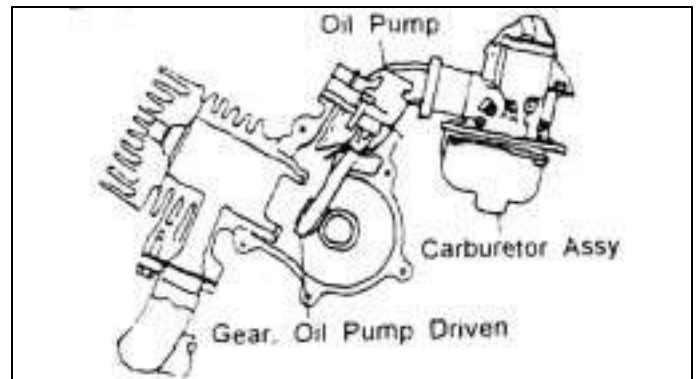

B. Oil-Pump: Double outlets type ,
The Injection Volume Increased by The
Revolutions of Crankshaft and The
Opening of Throttle.



C. Forced Air-Cooled Engine:

In order to achieve the stable cooling both when the vehicle is moving and parked, it is covered with air guide from the Cooling Fan to the Cylinder Head. The outside air is imported into the Cylinder-Head and Cylinder by the Cooling-Fan on the Flywheel Magneto to achieve the cooling effect.

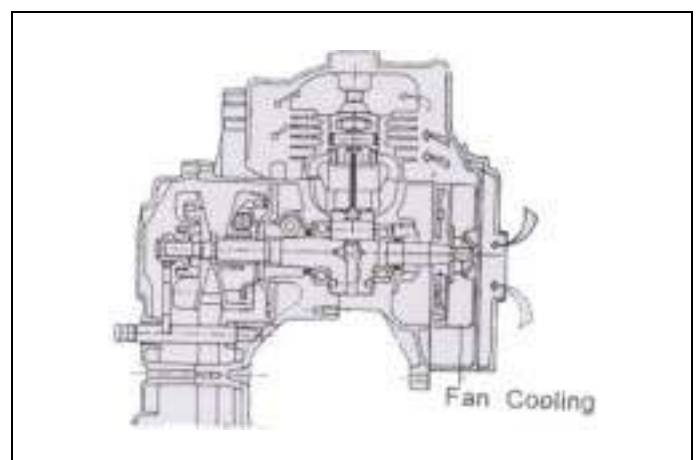

3-2 TRANSMISSION MECHANISM

3-2-1 Path of Power Transmission:

The torque of Crank-Shaft from Drive Face to Belt Driven Face Clutch Shoe Clutch Housing Drive Shaft, through Idle Gear in Mission Chamber Turning Speed reduced by Final-Gear and Power transmitted to Rear-Axle Shaft to move Rear Wheel.

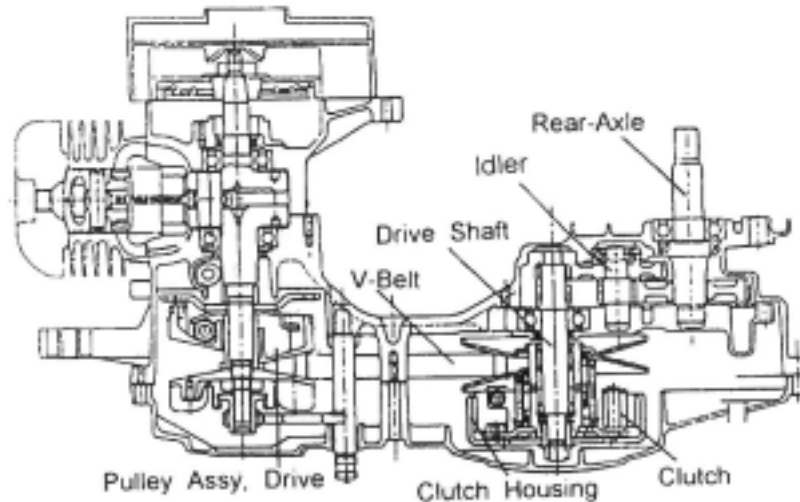

3-2-2 Belt Automatic Continuous Variable Transmission:

The Transmission is the combination of automatic centrifugal clutch and V-Belt continuous variable transmission, which makes the Pulley of both Drive Ends and Driven Ends move toward the shaft center to alter V-Belt contact pitch circle to change the transmission ratio automatically.

Due to the increasing revolution speed of Engine, the pitch circle on the Drive Pulley is enlarged by centrifugal force and pushed out of the Belt to lengthen the radius of pitch circle.

The Belt at Driven Pulley Face is forced to move to the center of shaft to decrease the radius of pitch circle, and pushed by the spring to transfer the power.

The transmission ratio is therefore altered by the alteration of pitch circle's radius.

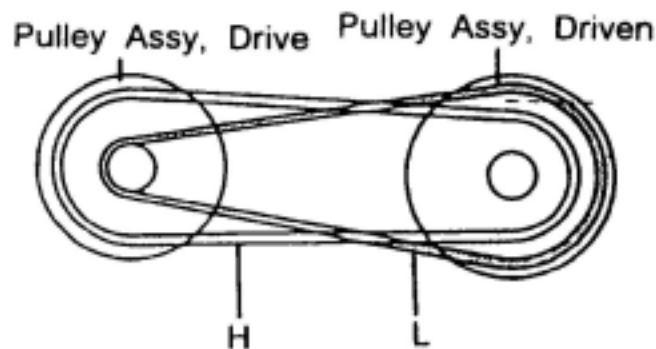

3-2-2 Continuous Variable Transmission

1 . V-Belt :

Made of rubber fiber, resistant to heat, pressure and abrasion. The inner side of the Belt is toothed.

2 . Drive Pulley :

- A. Due to the increasing revolution speed of Engine, the Roller in the Movable Drive Face is expanded by the centrifugal force to move the Movable Drive Face and squeeze and press V-Belt to enlarge its turning radius.
- B. Fan is installed on the exterior of Fixed Drive Face to moderate the rise of temperature in the Clutch-Cover.

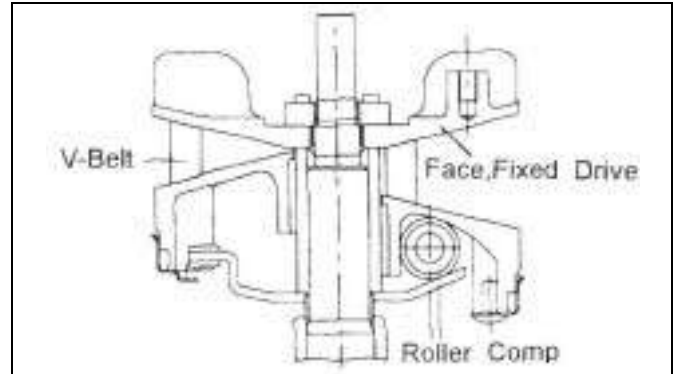

3 . Driven Pulley :

- A. Because the revolving radius of V-Belt at the Drive End is enlarged, the Face Comp Movable Drive is squeezed out by the V-Belt at the Driven End to shorten the revolving radius.
- B. There is a Torque Cam on the Movable Drive Face.
- C. Torque Cam is loaded from outside. When the outside load is higher than the engine's output, the Pulley of fixed shaft and Belt slip to make the Movable Drive Face move along the inner side of Cam and compensate to increase to high torque (toward to low speed) and make the engine maintain smooth running with original revolution.

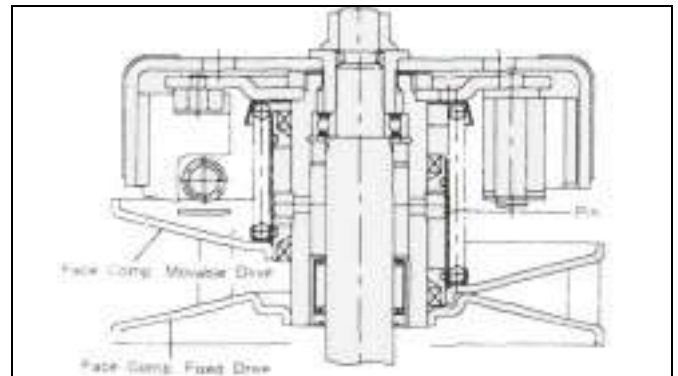

3-2-2 Continuous Variable Transmission

4. Running Curve:

- A. During general speeding, continuous variable transmission is achieved smoothly along with its speed.

- B. During quick speeding, because the torque cam begins to act, the quick transformation can be achieved in high speed.

- C. After the transmission, the scooter speed can also rise according to the ratio with the rise of revolving speed of Engine.

3-2-3 Reducing Gear

The power received by the Drive Shaft will be transmitted by the speed reduction of two sets of Gear to Rear Axle Shaft.

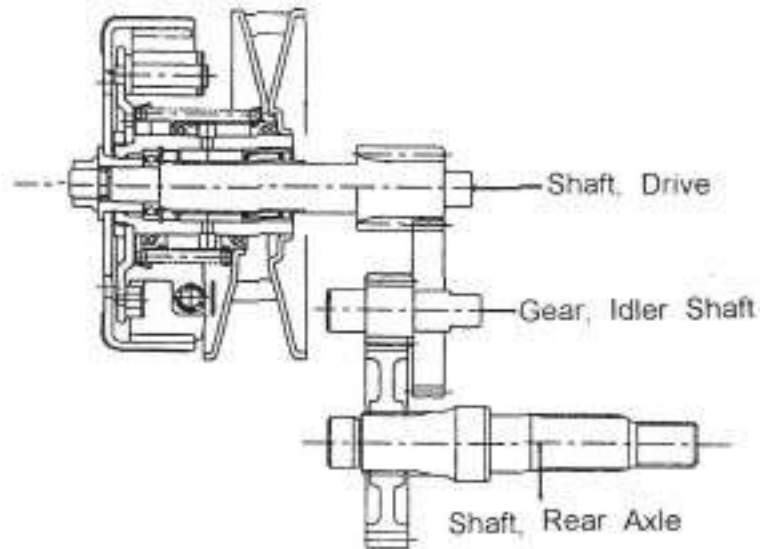

3-2-4 Starting Mechanism:

The starting mechanism includes

I. Electric Self-Starter :

- A. Starting Motor of BENDIX type. With Safety Starting Mechanism.
- B. The Starting Motor can act only when the Front-Brake or Rear-Brake is applied.
- C. Starting Motor is installed at the front bottom of Crank Case .
- D. Starting Motor Relay is installed in the inner side of the Front Leg-Shield.
- E. Starter Switch is installed on the Right-Hand Handle. Starter Motor revolves to activate Pinion Gear Assy. to fly out of the Pinion-Gear and connect with the Starter Gear.

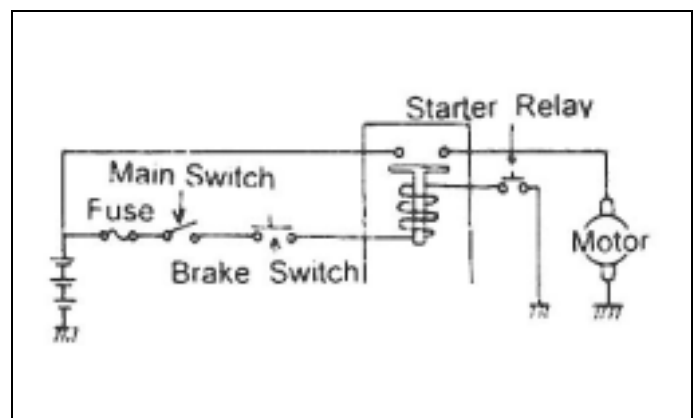
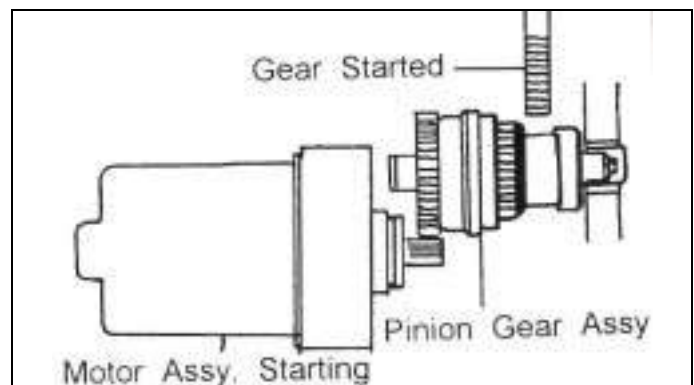

3-2-4 Starting Mechanism:

2 . Kick starter :

- A. To start the scooter by kicking, the center Stand has to be erected and the Brake-Lever has to be under brake condition.
- B. When the Kick-Starter Lever is kicked, the umbrella type gear of Starter Shaft will drive the right hand kick starter to revolve the crank shaft to start the engine.
- C. After the Engine is started, the Ratchet of the Left-kick Starter will stop the power transmission to the Kick-Starter Driven Gear.
- D. When the Kick-Starter Lever is released, the Kick Starter Gear will remove from Kick-Starter Driven Gear and go back to its original place.

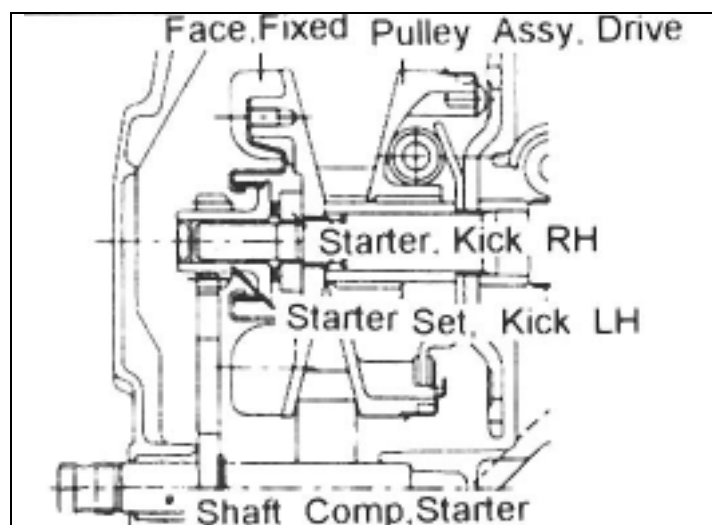

3-3 ELECTRIC SYSTEM

3-3-1 Ignition & Charging Device

1. Ignition Device:

CDI Unit of two ignitions per revolution is adopted.

The ignition Lead is $18^\circ \pm 3^\circ / 4,000\text{rpm}$ (OLD)

$15^\circ \pm 3^\circ / 4,000\text{rpm}$ (NEW)

2. Charging Device:

Power is given by flywheel magneto. The voltage is controlled by voltage regulator.

Power is charged to battery.

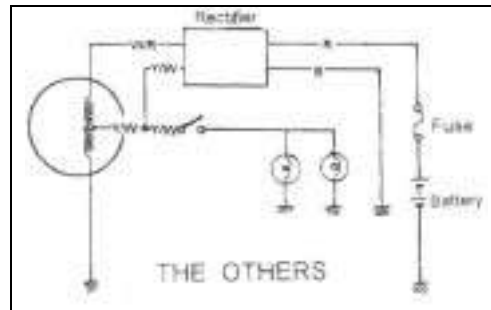
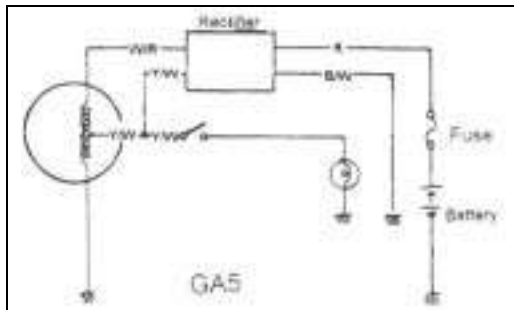

A. Flywheel Magneto:

Flywheel (rotor) includes four poles, crossed N poles and S poles. The stator consists of one high-tension ignition coil and three low-tension coils for charging and lighting to create change of magnetic field by rotating the flywheel to generate electricity.



3-3-1 IGNITION CHARGING DEVICE FOR THE IGNITION

B. Battery : The Battery have two types of Water-adding and Water-Adding Free.

1. Battery Caution:

1. The electrolyte contains sulphuric acid is poisonous. avoid to contact with eye, skin and clothes. Immediately wash with abundant water and call a doctor at once in case of contact with the eyes or skin. Immediately drink beaten eggs or vegetable oil, call a doctor at once in case of drink.
2. batteries release explosive gases, prohibit to closed to sparks, flames or cigarettes.
3. When charging or using the battery in a closed location, make sure that ventilation is good.
4. Keep off children hands.

2. Instruction for Filling Electrolyte (For Water-adding Free Battery)

1. Remove the Aluminum Seal on the filling hole of battery.
2. Remove the cover bar and battery sealing bolt.
3. Insert the filling hole of electrolyte container into the filling hole of battery. Try not to spillage it.
4. There are three pipes on each side. Tap the bottom of container lightly when the electrolyte bubbles. Pulling it out will be unnecessary.
5. Remove the container from the battery after all electrolyte is filled into battery.
6. Insert the fixing plug in the filling hole of battery and press the fixing plug until it is not higher than the top of cover.

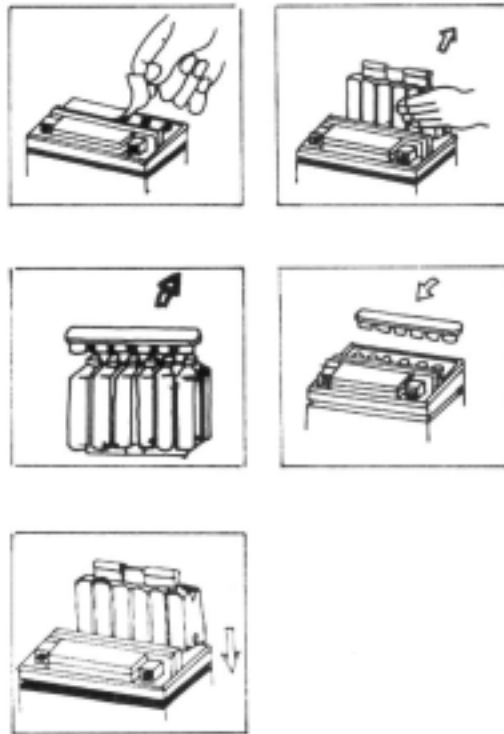

Note : The Battery is completely ready to use, thus do not remove the Aluminum Seal on the closed filling hole until it is to be used. Electrolyte, except those specified, is absolutely forbidden. While filling the electrolyte, only regulated volume of electrolyte can be adopted. The seal plug should not be removed after the electrolyte is added.

3. THE PROCEDURE OF USING NEW BATTERY (FOR WATER-ADDING BATTERY)

1. Use the open long plastics tube to instead of the L-Type closed rubber tube; adjacent to the "+" pole of the battery.
2. Cut off the tip of the electrolyte's bottle, and put on the open rubber tube. Take off the fixing plugs on the battery.
3. Pour the electrolyte into battery carefully to reach the upper level and the density must be 1.28/20
4. The battery must be stay to decrease the temperature of the electrolyte to under 35 . Then begin to charge.
5. Lay the battery for 30 minutes, if battery stay long time, it must recharge again also according to the table . (see item 5)

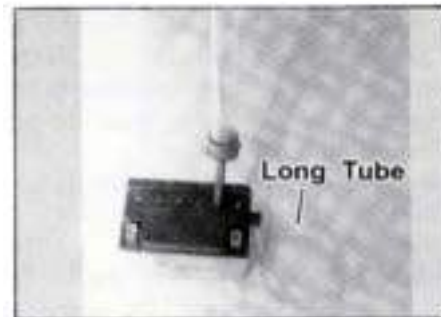
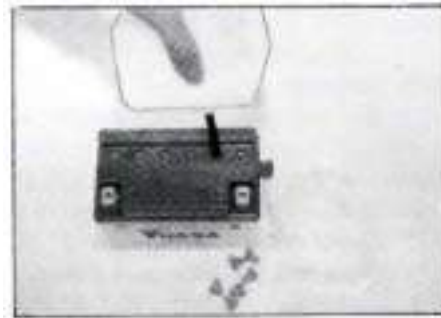

Time interval after made	Within 3 months	After			within 1 year	above 1 year
		3 months	6 months	10 months		
Charging time	Unnecessary to charge. Pour electrolyte into battery. Lay 30 minutes, then begin to use.	10 hours	20 hours	30 hours	40 hours	60 hours

6. Connect the black lead to the "-" pole of battery and red to "+" pole put the battery to the location and clamp the rubber band.
7. For the connected plastics long tube to the air vent hole of battery , the other end of the tube must be setted through into the square hole in the plastic leg shield rightly to discharge the erosive air or sulfuric acid to avoid eroding the body. The tube must be without plugging or straight bending to avoid exploding.

CAUTION:

It's important to use open long tube to instead of close short tube to assure normal output of gas to prohibite of exploding.

4. BATTERY MAINTENANCE: (FOR WATER-ADDING BATTERY)

1. Use the same key of main switch to turn right or left to open inner box lid, then disconnect the battery band and take out the battery, finally take off cable.
2. Checking electrolyte, add distilled water to refill and adjust to upper level; in case of adding distilled water frequently, checking the over-charging of the battery: No voltage indicated on the terminal or no action on rectifier, means short on the battery, the voltage will be higher than normal, and the life will shorten.
3. Inspect charged condition:
Add electrolyte to the upper level and check by battery hydrometer (as attached drawing). The density of charged battery must be 1.26~1.28 (above 20 °C), if the density below 1.2/20 °C, it means fully discharged and must be recharged; The battery must be checked electrolyte level, density and the voltage after charging.

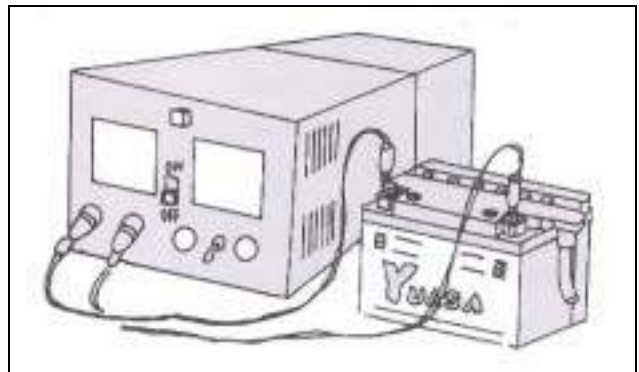

5. RECHARGING OF THE BATTERY

To Take off the fixing plugs of the battery before charging. Use 1/10 current intensity of the capacity to recharge the battery about 15-20 hours at normal condition; connect "+" pole of the battery to "+" pole of the charger, and "-" with "-".

CAUTION:

1. Keep the battery away from flames, sparks, and cigarettes.
2. If the temperature of the electrolyte is higher than 45 °C, it must be changed to half of the current intensity or stop to charge until it decreases to get under 35 °C.
3. After charging the battery, adjusting the electrolyte to upper level and recharge 1-2 hours again, then put into the fixing plugs, washing and protect with vaseline.
4. Disassemble the "-" pole terminal at first before taking out the battery from scooter, begin to assemble the "+" pole terminal reversely.
5. If it couldn't reach to 12V, after charging the battery for 15-20 hours, it's necessary to replace new battery.

6. REGULAR MAINTENANCE OF THE BATTERY

1. Keep the battery clean and dry.
2. Protect the terminals with vaseline.
3. It can reduce the time to 5-6 hours to charge battery at urgent case.
4. Don't use fuse which above standard, otherwise it'll cause broken of scooter or even firing
【10A(GA5),7A(THE OTHERS)】
5. It must be charged before using new battery (If necessary stated on table of ITEM 3) to keep the maximum performance, if don't charging adequately or the electrolyte under the low level, it may cause broken before normal life.
6. Tap or drinking water contain mineral will reduce the battery's life, it must be used distilled water. (For Water-Adding battery)
- 7 If scooter is stay a long time, it required charged periodically, otherwise it'll fully discharged by itself above three months.

3-4 BODY

3-4-1 Frame & Fuel and Oil System

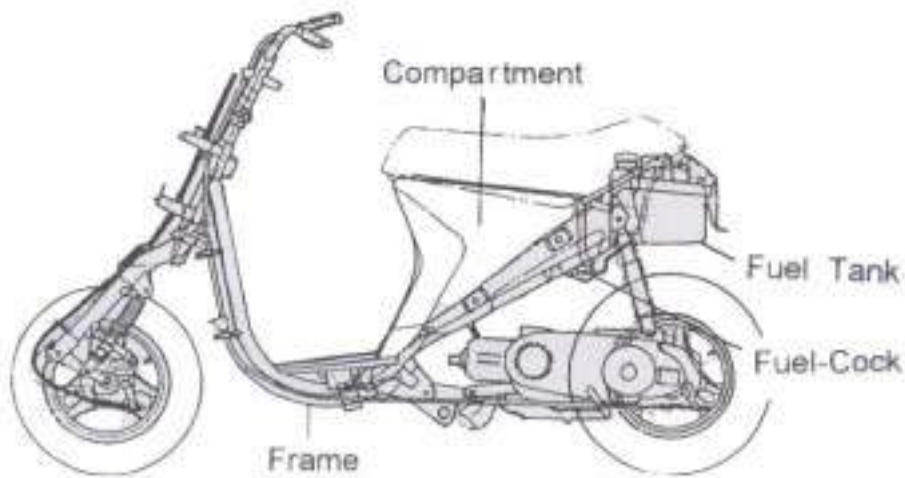

1 . Frame :

- A. steel pipe and steel sheet are adopted to compose reinforced frame.
- B. A compartment as Personal space for Helmet is set in the Frame center.



2 . Fuel Tank

- A. Fuel Tank is made of plastic or steel including electric Fuel-Level- guage.
- B. When the Fuel Gauge is in the E-Line, there is about 1L of preserved fuel.



3 . Oil-Tank :

Oil Tank is made of plastic, including electric Fuel-Level-guage, with the capacity of 0.8L.
When the red indicating lamp of Oil Level is lit, there is about 220 c.c. preserved oil.



4 . Fuel-Cock:

Automatic Cock of negative pressure model.

3-4-2 Compartment and Seat

1 . Compartment:

- A. Located in the center of scooter body, there is a Personal Space for helmet and other, etc.
- B. The maximum load capacity of compartment is 10kg.
- C. Please don't store precious or easy-to-break articles in the compartment without any protection.
- D. The Seat has to be locked. If the Seat is not locked during riding, it will affect the safety and even cause injury.
- E. Please pay attention not to let fuel or oil drop into the compartment.
- F. The cover of the compartment can be cleaned with vacuum cleaner.
It can also be washed and put back after dried.
(Please do not wash with volatile fluid, such as gasoline.)
- G. The seat is controlled by the seat lock on the side.
The seat is about 710mm (GF) and 800mm (GI) high from the ground.

2 . Helmet Holder:

There is a Helmet Holder at the position of Seat Hinge.
open the Seat to hook or unhook Helmet.

3-4.3 Front & Rear Suspension System

I. Front-Fork :

A. There are Two Types OF Suspension on Front Fork , one is Bottom Link Type Front Fork. The other is Internal Damper Type Front Fork.

a . Front Fork of Bottom Link type including an absorber with compression spring and hydraulic buffer on right hand and left hand side each.

b. Front Fork of Internal Damper Type Including Aluminum Tube with nternal Spring Hydraulic Buffer on RH and LH side each.

B. Brake Con-rod and Bracket of Brake Lining are equipped between Front Fork and Disc Brake. Resistant Torque occurs toward the revolving direction when acting brake. The Torque will become the force to push Front-Fork up by using connection Rod. Therefore, the sink of Front-Fork is stopped and decreases the change of sitting gesture while the brake is used.

2 . Rear-Suspension :

A. Swing-Arm Suspension Mechanism is composed of single telescopic absorber between the crank case and scooter body.

B. Rear Axle Movable by telescopic shock absorber.

3-4-4 Brake System

I . Front Brake: (Disc Brake)

Hydraulic disc brake includes disc brake disc, brake caliper, brake oil hose, and master cylinder with oil level manhole.

It is operated manually by pulling the front brake on the right hand handle-lever.

LINK TYPE
(DRUM BRAKE)



LINK TYPE
(DISC BRAKE)



INTERNAL
TYPE
(DISC BRAKE)



FOR
BH/BR/BK
TYPE

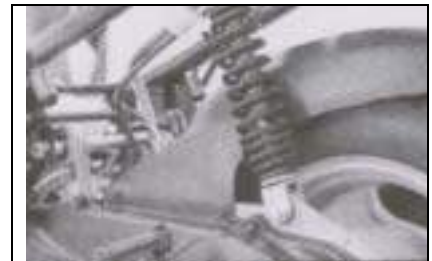

FOR THE
OTHERS



CHAPTER 4 . DISASSEMBLY REPAIRS

4-1 NOTICE FOR DISASSEMBLY REPAIRS

4-2 REMOVAL AND INSTALLATION OF ENGINE

4-2-1 Removal of Engine

4-2-2 Installation of Engine

4-3 DISASSEMBLY AND ASSEMBLY OF ENGINE

4-3-1 Disassembly of Engine

4-3-2 Inspection of Engine Parts

4-3-3 Assembly of Engine

4-4 REMOVAL AND ASSEMBLY OF CARBURETOR

4-4-1 Removal of Carburetor

4-4-2 Inspection of Carburetor

4-4-3 Assembly of Carburetor

4-5 REMOVAL AND INSPECTION OF ELECTRIC ITEMS

4-5-1 Removal and Inspection of Ignition and Charging System

4-5-2 Removal and Inspection of Starter Mechanism

4-5-3 Removal and Inspection of Fuel Meter and Level Meter

4-5-4 Removal and Inspection of Oil Indicator and Level Meter

4-6 REMOVAL AND INSPECTION OF BODY PARTS

4-6-1 Removal of Front Fork

4-6-2 Inspection of Front Fork

4-6-3 Removal and Inspection of Brake

4-6-4 Assembly of Front Brake and Front Wheel

4-6-5 Inspection of Steering

4-7 BUILT-IN BRAKING SYSTEM

4-1 NOTICE FOR DISASSEMBLY INSPECTION

1. In order to avoid mixing and loss of disassembled parts before reassembling, the disassembled parts have to be arranged according to their function during the process.
2. The damage to Cover and Frame should be avoided while disassembling and assembling.
3. Remove the negative (-) terminal of Battery before working.
4. While reassembling, make sure that all parts are normal.
5. Specified oil should be adopted on turning and sliding parts.
Specified grease should also be applied on specified positions.
6. Dust, dirt and unusual articles should be avoided while reassembling.
7. When important revolving and reciprocating parts, such as Cylinder Head, Cylinder, Piston, Piston-Ring, and Crank, have been replaced, the vehicle can not go for full speed running immediately. Preliminary running should be applied below 4000 rpm within 500km.
- 8 . While assembling, the main lip of oil seal should face inwards (oil chamber) and the antidust sub-lip should face outwards.
Apply an even layer of specified grease onto the lip before it is pressed to its location with balanced force by specified jigs.
- 9 . While pressing the bearing into the hole, apply balanced force to the outer ring of bearing by specified jigs.
While pressing the bearing into the main shaft, apply balanced force to the inner ring of bearing by specified jigs.

4-2-1 Removal of Engine

A. Remove Ignition Coil Lead(1)
Flywheel Magneto Lead(2)
Engine Earth Ground Lead(3)
Auto-Choke cable (4) .

B. Remove the Throttle Cable
on Carburetor Piston(5).

C. Remove Oil Hose(6).

D. Remove Negative Pressure Hose (7) and
Remove Fuel Hose(8).

E. Remove Rear Brake Cable(9).

F. Remove Engine Mounting Shaft (10) .

G. Remove Rear Shock Absorber(11)

H . Lift Body



4-2-2 Installation of Engine

- A. Lift the body and point the bottom end hole of crank case bracket to the two front holes of engine crank case.
Install Engine Mounting Shaft and lock.
- B. Install Ignition Coil, Flywheel Magneto , Engine Earth , and Auto-Choke Cable .
- C. Install Oil Hose. Release the bubble by releasing Bolt on the Oil Pump to let the oil flow .
Relock the Bolt until no bubble appears.
- D. Install Carburetor negative pressure hose (1), fuel hose(2).
Make sure to lock the circlip.
- E. Install Rear Shock Absorber(3) by passing through the absorber bolt from the left of scooter body.
- F. Install Rear Brake Cable (4) and adjust the gap of rear brake lever in 15~35mm.

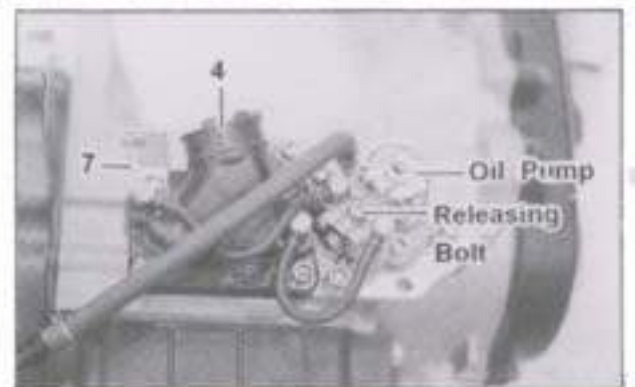
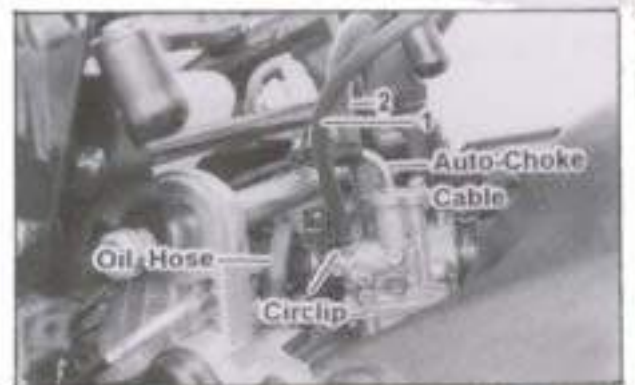

4-3-1 Disassembly Sequence of Engine

1. Remove the Muffler.
2. Remove the Kick Starter.
Remove the Clutch.
Remove the Spring of Kick Starter Rod.
Remove the Kick Starter Shaft Comp.
3. Remove the Spring Seat.
Remove the Washer.
Remove the Left Hand Starter.
Remove the Right Hand Starter.
Remove the Drive Face.
Remove the V-Belt.
Remove the Movable Drive Face Comp.
Remove the Spacer.
Detailed Disassembly:
Remove the Cover.
Remove the Movable Drive Plate.
Remove the Rotor Assembly.
Remove the Guide Block.
Remove the O-Ring.
4. Remove the Nut of Clutch Housing.
Remove the Clutch Housing.
Remove the Driven Belt Pulley.
Detailed Disassembly:
Remove Nut of Driven Pulley Assy.
Remove Clutch Assy.
Remove the Spring.
Remove the Spring Sheet.
Remove the Roller Pin.
Remove the Fixed Shaft Assy.
Remove the Needle Roller Bearing.
Remove the C Type Circlip.
Remove the Ball Bearing.
Remove the O-Ring.
Remove the Oil Seal.
5. Remove the Fan Cover.
Remove the Cooling Fan.
Remove the Fan Case.
Remove the Air Filter.
Remove the Nut of Flywheel Magneto.
Remove the Flywheel Magneto.
Remove the Coil Assy.
6. Remove the Starting Motor.
Remove the Cap of Starter Idler Gear.
Remove the Starting Gear.
Remove the Pinion Gear Assy.
7. Remove the In-take Pipe Assy.
Remove the Reed Valve.
8. Remove the Oil Pump Assy.
Remove the Oil Pump Driven Gear.

4-3-1 Disassembly Sequence of Engine

9. Remove the Ignition Coil.
Remove the Spark Plug.
Remove the Cylinder Cover.
Remove the Cylinder Head.
Remove the Cylinder.
10. Remove the Snap Ring of Piston Pin.
Remove the Piston Pin.
Remove the Piston.
Remove the Piston Ring.
Remove the Needle Bearing.
11. Drain the Gear oil.
Remove the Cover of Gear Box.
Remove the Drive Shaft.
Remove the Snap Ring of Rear Axle Gear.
Remove the Washer of Idle Shaft.
Remove the Rear Axle Gear.
Remove the Idling Shaft.
Remove the Washer.
Remove the Snap Ring.
Remove the RH and LH Bearings and Oil Seal of Main Shaft.
12. Remove the Nut of Rear Wheel.
Remove the Rear Wheel.
Remove the Lining of Rear Brake.
Remove the Rear Wheel Shaft.
Remove the Cam Con-Rod of Rear Brake.
Remove the Cam of Rear Brake.
Remove the oil seal, Bearing of Rear Shaft.
13. Remove the Spring of Center Stand.
Remove the Shaft of Center Stand.
Remove the Center Stand.
14. Remove the Right Hand Crank Case.
Remove the Crank Shaft Assy.
Remove the Oil Seal of Right Hand Crank Case.
Remove the Bearing of Right Hand Crank Case.
Remove the Bush Comp.
Remove the Oil Seal of Left Hand Crank Case.
Remove the Bearing of Left Hand Crank Case.

Remark: " " means that special tools are needed.

4-3-1 Disassembly of Engine:

(Muffler, Kick Starter Lever Assy, Drive Pulley Assy .)

1. Removal of Muffler

block (14).

2. Removal of Kick Starter Lever

Assy:

- A. Remove the hexagon bolt (15) of kick starter lever assy (16) and remove the kick starter lever assy.
- B. Remove the fixed screw of clutch cover.
- C. Remove the Spring (17) of kick starter shaft .
- D. Remove the kick starter shaft (18).
- E. Remove the bush (19) of kick starter shaft

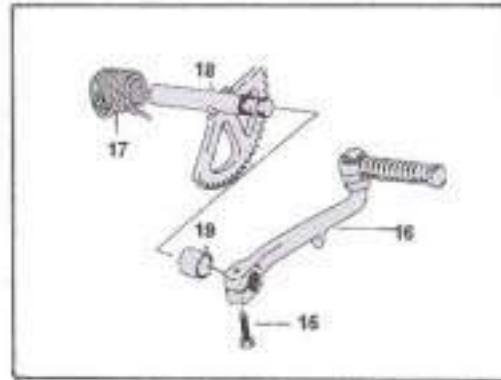

3. Removal of Drive Pulley:

- A. Remove screw (1).
- B. Remove spring seat (2).
- C. Remove spring (3).
- D. Remove washer (4).
- E. Remove the left hand starter assy (5).
- F. Remove the RH starter (6).

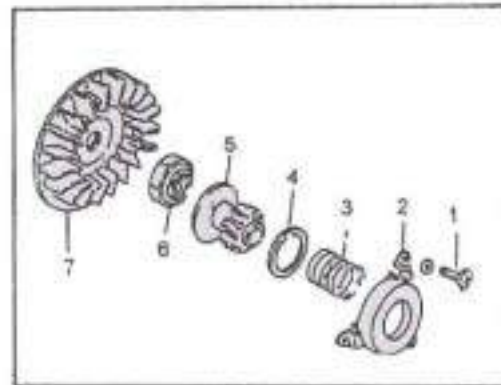

WARNING

Because it is LH thread inside the RH starter, it is necessary to use deep bush while removing (to avoid contact with the crank shaft), and remove the RH starter by using pneumatic wrench turns to right hand. If it turns to left hand, the wrong direction, it will damage the crank shaft easily.

Special Tool: GA5000051F36.

If manual wrench, instead of pneumatic wrench, is adopted, stop tool will be needed.

Special Tool: GA5000051F3.

- G. Remove Movable Drive Face (7).
- H. Remove V-Belt (8).
- I. Remove Drive Pulley Assy (9) and Spacer (10)
Press the Movable Drive Plate and Drive Pulley Face while removing the Drive Pulley Face Assy in order to avoid the roller to stand up.
- J. Disassembly of Driven Pulley Face Assy:
Remove screw (11), Movable Drive Plate (12), roller (13) and guide

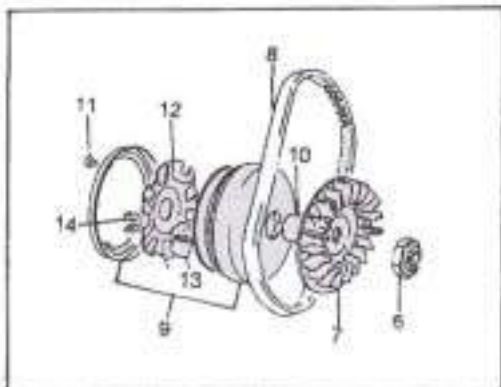

4-3-I Disassembly of Engine: (Removal of Driven Pulley Assy)

4. Removal of Driven Pulley Assy:

- A. Remove Nut of Clutch Housing with pneumatic wrench or stop tool as shown.

special Tool: GA5000051F04.

- B. Remove the Clutch Housing.
C. Remove the Driven Pulley Assy.
D. Apply Special tool to prohibit the rotation of Clutch Assy.

Warning

It is not allowed to release the nut quickly because the components will fly out and cause injury. Release lightly will be enough.

special Tool: GA5000051F04.

- E. Press tightly the both sides of Clutch, unscrew and remove the Nut.

Warning

Press tightly the Clutch Assy while unscrewing the Nut, so that the spring will not jump out. Release slowly after the nut is removed.

- F. Remove the Clutch Assy.
G. Remove the Spring.
H. Remove the Spring Sheet by screw driver or by hand.
I. Remove the Guide Pin.
J. Remove the Fixed Driven Face Assy.
K. Remove the Needle Bearing.
L. Remove the C-type Snap Ring.

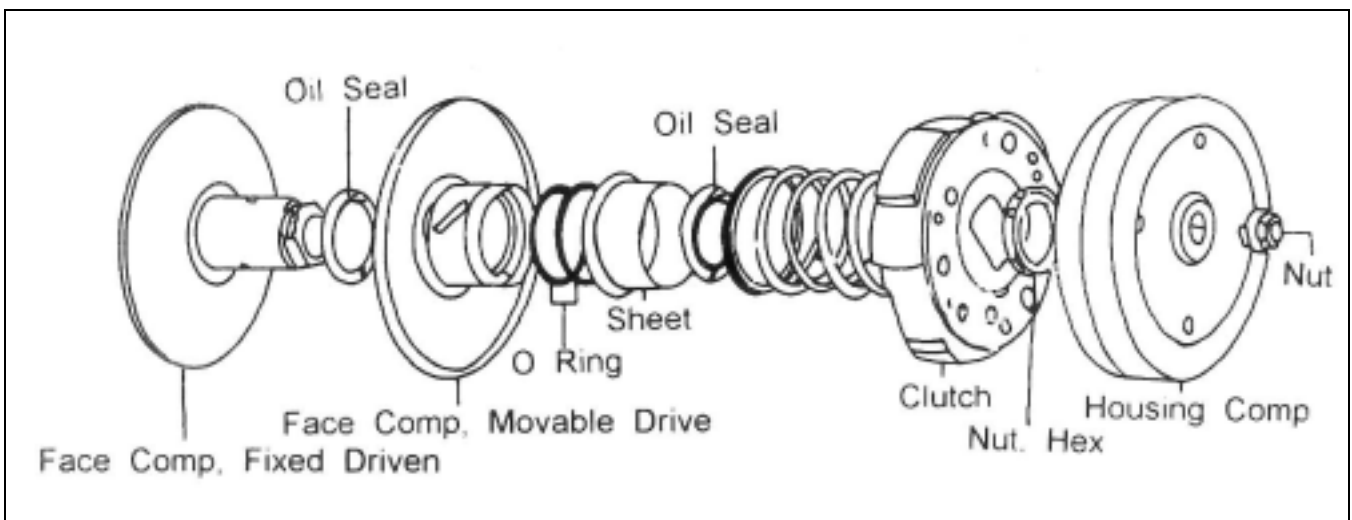
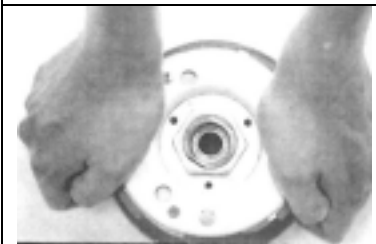
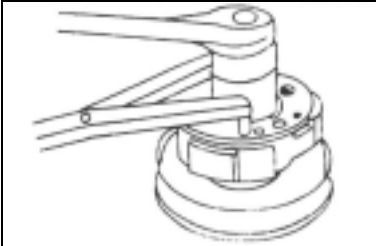
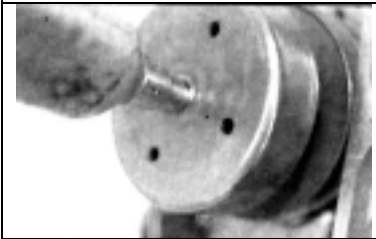
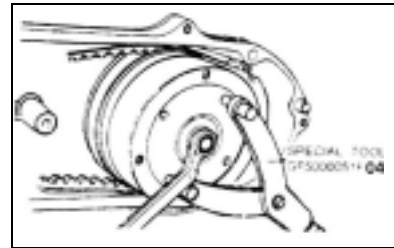

4-3-1 Disassembly of Engine: (Removal of Flywheel Magneto and Starter Motor)

5. Removal of Flywheel Magneto:

- A. Remove the Screw of Air Filter and remove the air filter.
- B. Remove the Screw of Fan-Cowling and remove Fan-Cowling.
- C. Remove the Screw of Cooling Fan and remove the Cooling-Fan and Fan Case.
- D. Tools should be adopted to prevent the rotation of Flywheel Magneto. Remove Flange Nut of Flywheel Housing.

Special Tools: GA5000051F04

- E. Apply tools to lock on the thread hole of Flywheel Housing, hook the end of Crank Shaft and remove the Flywheel Housing

Special Tool: GA5000051F22

- F. Remove Key.
- G. Disassemble Screw of Coil and remove the coil.

6. Removal of Starter Motor:

- A. Remove the Screw (1) of Starter Motor and remove the Starter Motor.
- B. Remove the Drive Gear
- C. Remove the Screw (2) of Idling Gear Cover.
- D. Remove the Idling Gear Cover (3) and Speed clutch (4).

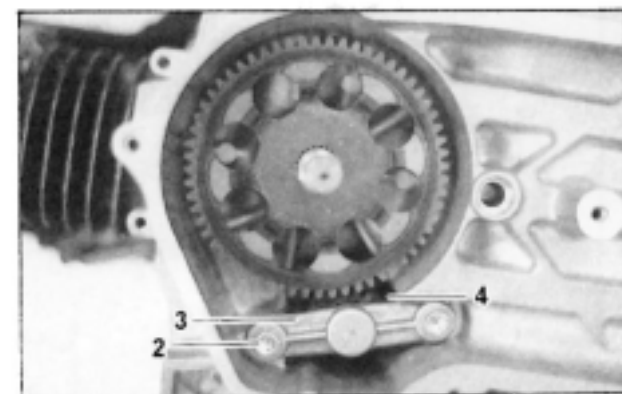
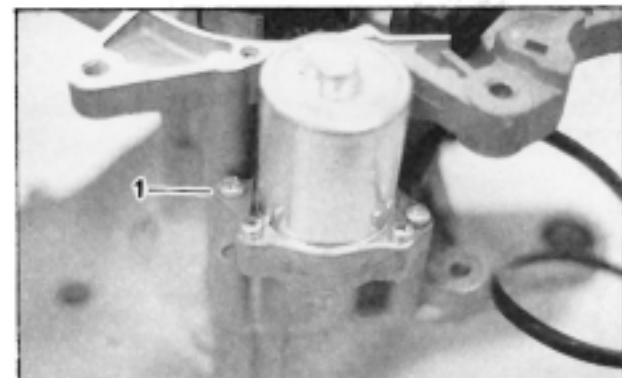

4-3-1 Disassembly of Engine: (Removal of In-Take Pipe, Oil-Pump and Cylinder)

7. Removal of In-take Pipe:

- A. Remove the Fixed Plate of Fender (1).
- B. Remove the In-take Pipe (2).
- C. Remove the Reed Valve (3).

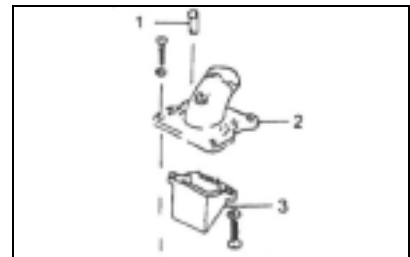

8. Removal of Oil-Pump:

- A. Remove Oil Pump (4).
- B. Remove Oil Pump Driven Gear (5).

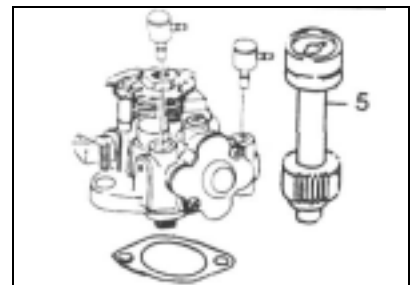

9. Cylinder

- A. Remove the Ignition Coil.
- B. Remove the Spark Plug.
- C. Remove Cylinder Cowling.
- D. Unscrew the Cylinder Screw by diagonal step.
- E. Remove Cylinder Head, Cylinder Gasket and Cylinder.

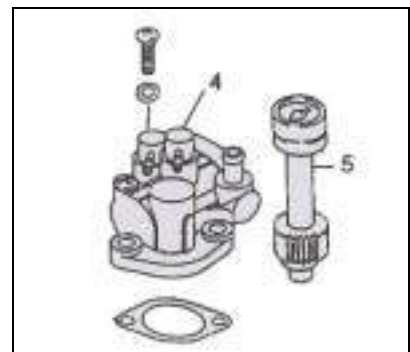

10. Piston

- A. Remove Piston Pin Cir-clip (6).
The used Circlip must be discarded and never to use again, otherwise it will be barred between piston and cylinder for looseness, and the engine is broken.
- B. Remove Piston Pin (7).
- C. Remove Piston (8)
- D. Remove Piston Ring (9).
Overexpanding is not allowed while removing Piston Ring, otherwise the Piston Ring will break or crack.
- E. Remove Piston Pin Bearing (10).

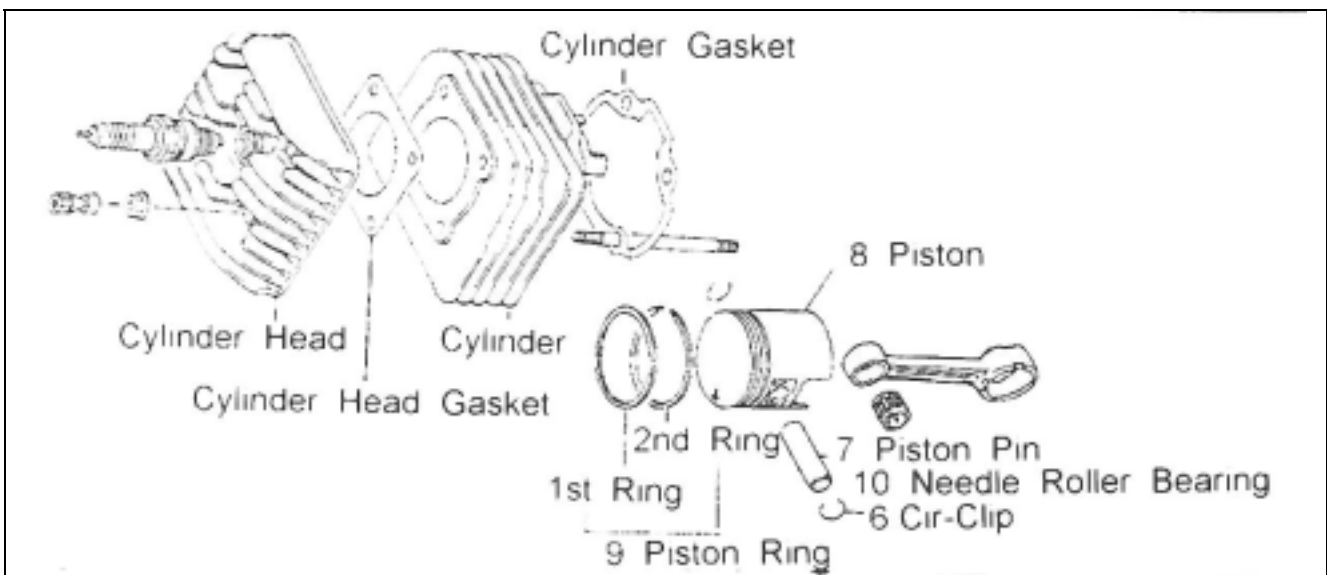

4-3-1 Disassembly of Engine: (Removal of Reducing Gear)

11. Removal of Reducing Gear:

- A. Drain the oil in the reducing gear box.
The Drain Screw of Engine has two designs, in the clutch cover or under the crank case.
- B. Unscrew the Fixed Screw lightly and evenly by diagonal step.
- C. Remove Gear Box Cover. Tap with plastic hammer if it can not be removed.
- D. Remove the Drive Shaft (1) from the Gear Box Cover.
- E. Remove the Cir-clip (2) of Rear Shaft.
- F. Remove the Left Hand Washer (3) of Idling Shaft.
- G. Remove the Gear (4) of Rear Shaft.
- H. Remove the Gear (5) of Idling Shaft.
- I. Remove the Right Hand Washer (6) of Idling Shaft .
- J. Hook the Right Hand Bearing (7) of Drive Shaft with special tool and remove the Bearing.
- special Tool: GA5000051F12.**
- K. Remove the Oil Seal (8) of Drive Shaft on the Gear Box Cover with screw driver.
- L. Remove the Left Hand Bearing (9) of Drive Shaft on the Gear Box Cover with special tool.
- special Tool: GA5000051F20.**

NEW

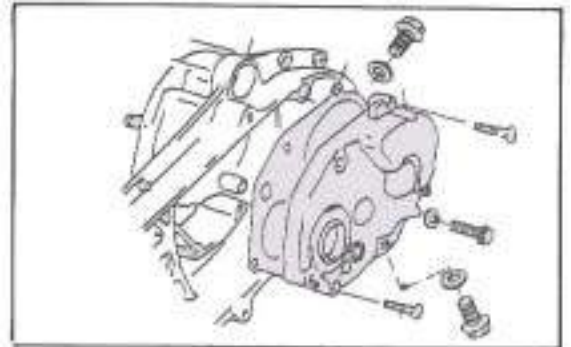

OLD

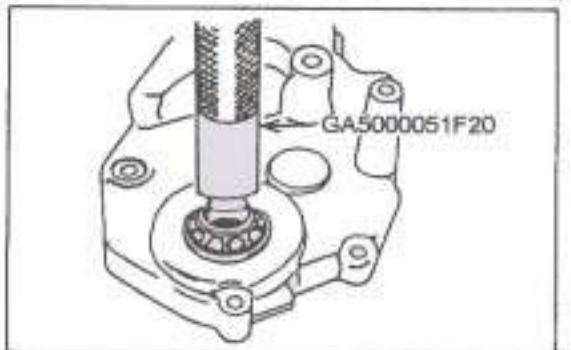
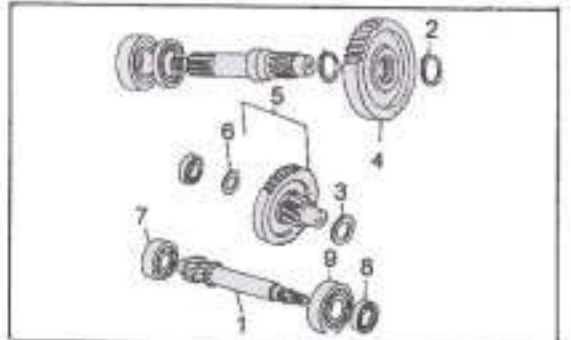
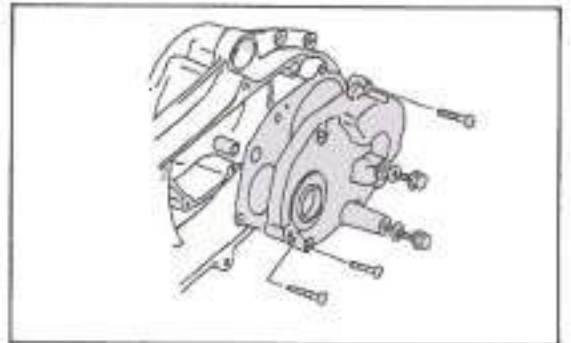

4-3-1 Disassembly of Engine: Removal of Rear Wheel

12. Removal of Rear Wheel:

- A. Remove the Fixed Nut (1) and washer of Rear Wheel and remove the wheel (2).
- B. Tap the Rear Wheel Shaft lightly from the Wheel End to the Gear Box to remove the Rear Wheel Shaft (3).
- C. Remove the Brake Lining (4).
- D. Remove the Spring (5).
- E. Remove the Cam Lever (6) of Rear Brake.
- F. Remove the Brake Cam (7).
- G. Remove the Screw (8) and Retainer (15) of Bearing.
- H. Remove the Bearing (9) of Rear Wheel Axle.
Special Tool: GA5000051F19.
- I. Remove the Oil Seal of Rear Wheel Axle with screw driver.

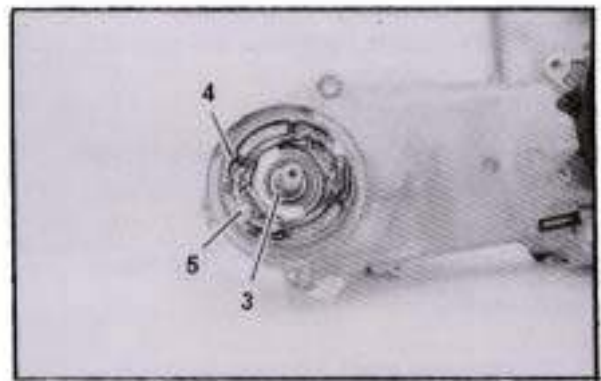

13. Removal of Center Stand:

- A. Remove Spring (10).
- B. Remove Cotter Pin (11) and Washer (12).
- C. Draw out Shaft of Center Stand (13).
- D. Remove Center Stand (14).

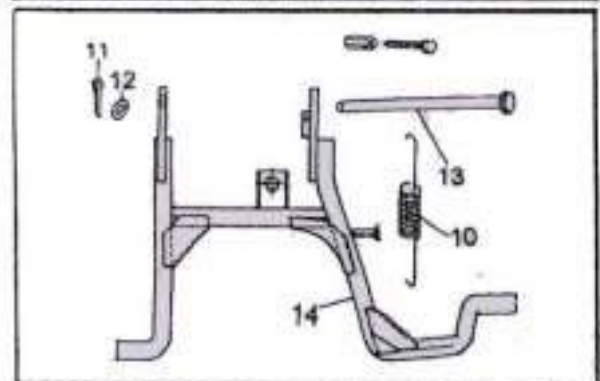
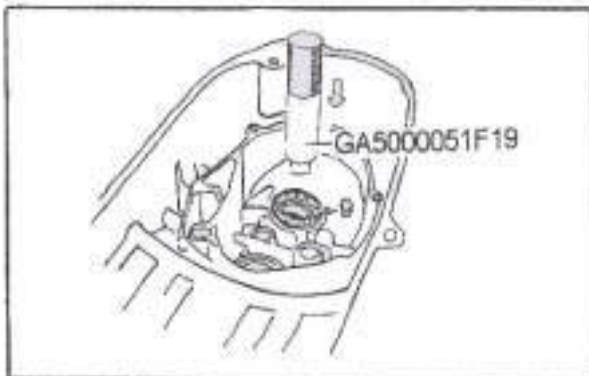
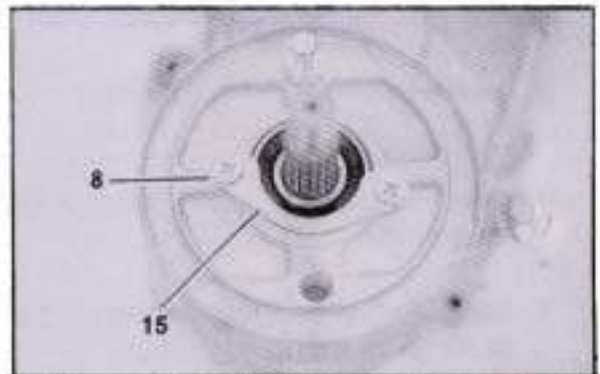

4-3-1 Disassembly of Engine: (Removal of Crank Case)

14. Removal of Crank Case :

A. Release Fixing Screw(1)
by diagonal step.

B. Use a special tool to lock Crank Case (2)
and Crank Shaft (3) to remove RH Crank
Case.

Special Tool: GA5000051F05

C. Use a special tool to lock LH Crank Case(4)
and Crank Shaft (3) to push out the
Crank Shaft.

Special Tool: GA5000051F05

D. Dig out the Oil Seal of RH Crank Shaft with
a screw driver.

E. Remove the bearing of RH Crank Shaft
with a special tool.

Special Tool: GA5000051F19.

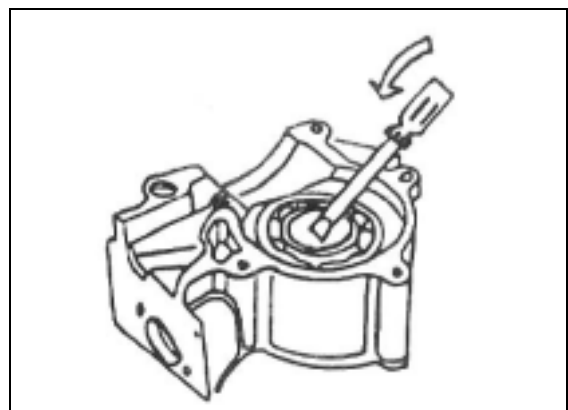
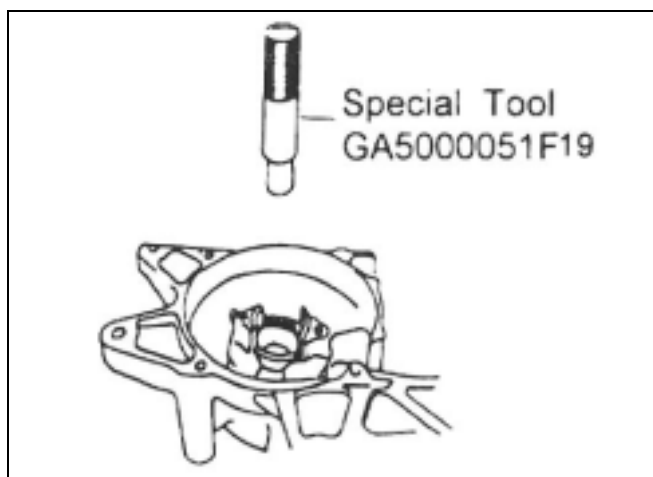
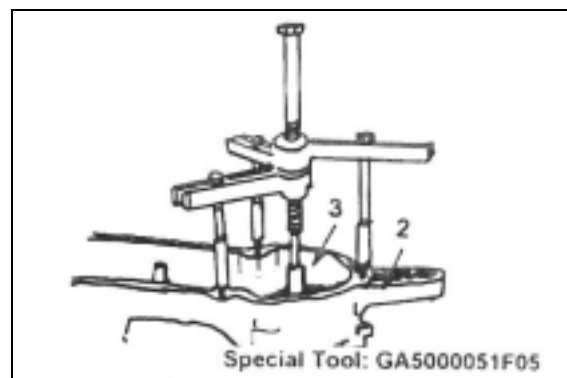
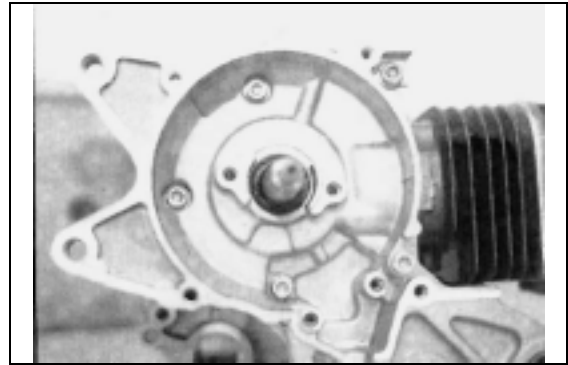

4-3-1 Disassembly of Engine: Removal of Crank Case

F. Pull the Oil Seal (1) of LH crank Shaft with a screw driver and remove the oil seal by tapping.

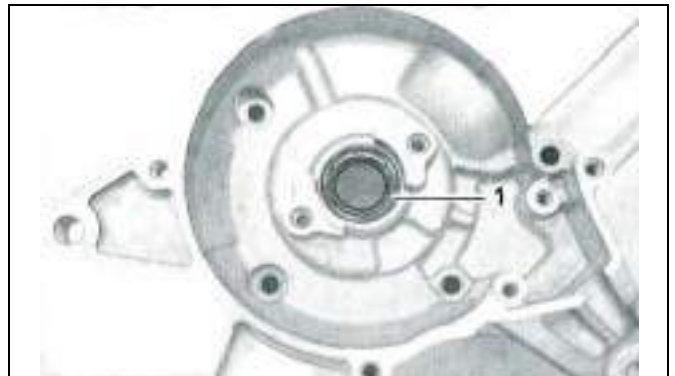

G. Remove the bearing (2) of LH crank shaft by tightening the nut of the special tool.

Special Tool: GA5000051F21

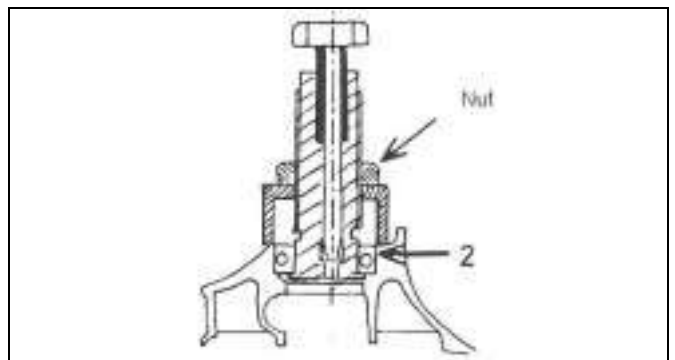

H. Put the crank case on the spacer shown. Push the outer ring of the bush with another spacer. And press the bush out with a vice.

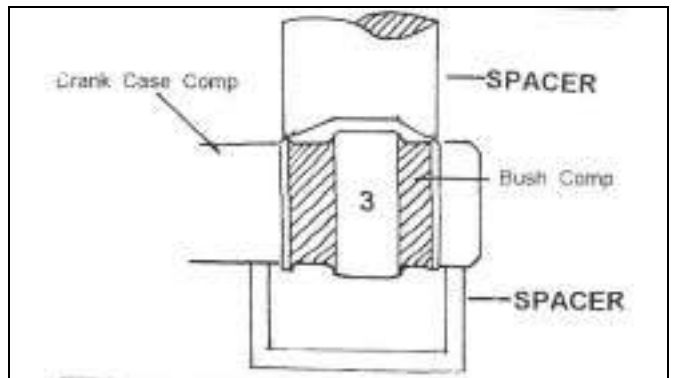

Reassembly : Assemble with the reverse sequence of disassembly.

4-3-2 Inspection of Engine Components

I. Measurement of Compression Pressure of Engine :

- A. start the engine to warm running up with a full-charged battery.
- B. Remove the spark plug and install the pressure gauge.
- C. Fully open the throttle lever and start the starter motor.
Read the indicator value on the pressure gauge.

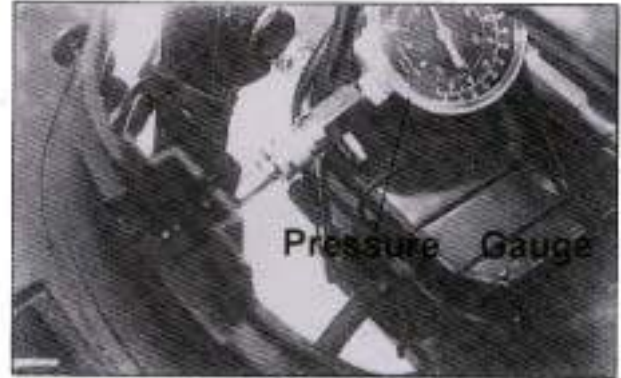

Compression Pressure :
Standard 6.8kg/cm²/500rpm

Limit 5.0gk/cm²



2. Turn the throttle stopping screw(1) and adjust to the revolution of 1800±100rpm
3. Turn the adjusting screw (2) of throttle cable and keep the clearance of steel cable in the throttle cable in 2~4mm (counted by outside diameter of throttle lever) .



4-3-2 Inspection of Engine Components

4. Inspection and Replacement of Reducing Gear oil:

A. Erect the Center Stand .

B. Remove the refilling bolt(3) on the LH crankcase.

Make sure if the gear oil reaches the bottom of refilling bolt.

C. Remove the refilling bolt(3) and drain bolt (4) to drain the gear oil.

D. Relock the drain screw (4).

Screw Torque: 40 ~ 70kg.cm

E. Refill 90cc of TGB gear oil from the oil inlet.

F. Tighten the oil inlet bolt.

Screw Torque: 90 ~150kg . cm

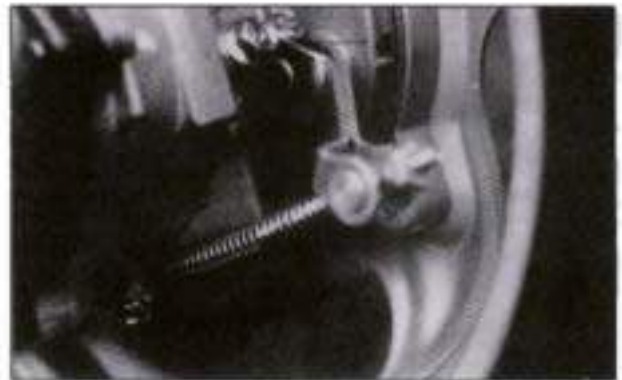

4-3-2 Inspection of Engine Components

5. Inspection of Cylinder:

- A. Check if any damage appears on the bore.
- B. Check if any damage or crack appear on surface.
- C. Excessive carbon deposit in the air outlet has to be cleaned.
- D. Replace if the cylinder bore exceeds **41.07mm**. (50C.C) **50.07 mm** (90 C.C)
- E. Repair will be needed if the flatness exceeds **0.1mm**.

6. Inspection of Cylinder Head:

- A. Inspect any crack or damage on surface.
- B. Excessive carbon deposit in the combustion chamber has to be cleaned.
- C. Repair will be needed if the flatness exceeds **0.1mm**.

7. Inspection of Piston Pin:

- A. Check for unusual damage, abrasion or color.
- B. Replaced when the exterior diameter is less than **9.98mm** (50C.C), **1.98mm** (90 C.C).

8. Inspection of Piston:

- A. Check for unusual damage, crack or abrasion.
- B. Measure the exterior diameter at **15m/m** (50C.C), **20m/m** (90C.C.) height above the piston bottom and the perpendicular to the pin hole.
Replaced if it is less than **40.89mm**. (50 C.C.) ,**49.89** (90 C.C.)
- C. Replaced when the piston pin hole exceeds **10.04mm** (50.C.C), **12.04 mm** (90 C.C.)

9. Inspection of Piston Ring:

- A. Check for unusual abrasion, damage or carbon deposit.
- B. Put the piston ring into the cylinder and measure the clearance of opening by thickness gauge. Replaced if it exceeds **0.8mm**.
- C. Put the piston ring into the piston, press tightly and measure the clearance between piston ring and the groove with thickness gauge. Replaced if it exceeds the limit of **0.02 0.07mm**.

10. Inspection of Crank Shaft:

- A. Check for unusual abrasion and damage from the appearance.
- B. Support the two bearings of crank shaft with V-shaped blocks and measure the deflection of two ends by indicator gauge. Replaced if it exceeds **0.08mm**.

4-3-2 Inspection of Engine Components

11. Inspection of Reed Valve:

- A. There should be no clearance between the reed and the reed valve seat.
- B. Check for any break from the appearance. Replaced if the flatness of contact surface exceeds **0.08mm**.

12. Inspection of V-Belt:

- A. There should be no oil stain, crack and unusual damage from the appearance.
- B. Replaced if the belt width is less than **15.0mm**.

13. Inspection of Clutch Housing:

- A. Inspect for any unusual damage and color change.
- B. Replaced if the inside diameter exceeds **110.40mm**.

14. Inspection of Clutch Spring:

- A. Inspect crack and damage from the appearance.
- B. Replaced when the free length at curved hook is above **25.5mm**.

15. Inspection of CVT Spring:

- Replaced if the free length of spring is less than **100mm**.

16. Inspection of Clutch Lining:

- A. Check for oil stain, crack and unusual damage from the appearance.
- B. Replaced if the thickness of lining is less than **2.0mm**.

17. Inspection and Cleaning of Air Cleaner:

- A. Remove the two slided hooks on Air Cleaner Cover.
- B. Remove Screw and Filter.
- C. Check for any damage and foreign material in the air cleaner.
Clean the inside of the air cleaner.
- D. Clean the Filter with cleaning oil or diesel fuel.
- E. Dry the Filter and soak in 10g of TGB Super Oil
No. GA50400002.

4-3-3 Assembly Sequence of Engine

1. Assemble the Bearing of LH Crankcase.
Assemble the Oil Seal of LH Crankcase.
Assemble the Bush.
Assemble the Bearing of RH Crankcase.
Assemble the Oil Seal of RH Crankcase.
Assemble the Crank Shaft.
Assemble the RH Crankcase.
2. Assemble the Center Stand.
Assemble the Shaft of Center Stand.
Assemble the Spring of Center Stand.
3. Assemble the Cam of Rear Brake.
Assemble the Cam Lever of Rear Brake.
Assemble the Oil Seal
Assemble the Bearing.
Assemble the Rear Wheel Axle.
Assemble the Lining of Rear Brake.
Assemble the Rear Wheel.
Assemble the Washer.
Assemble the Nut of Rear Wheel.
4. Assemble the RH Bearing of Rear Axle.
Assemble the Cir-clip of Rear Axle.
Assemble the Washer.
Assemble the Idling Shaft.
Assemble the Rear Axle Gear.
Assemble the Cir-clip of Rear Axle Gear.
Assemble the Oil Seal of Drive Shaft.
Assemble the LH Bearings of Drive Shaft.
Assemble the Drive Shaft.
Assemble the Cover of Gear Box.
Refill the Gear Oil.
5. Assemble the Needle Roller Bearing of Con-Rod.
Assemble the Piston Ring.
Assemble the Piston.
Assemble the Piston Pin.
Assemble the Cir-clip of Piston Pin.
6. Assemble the Cylinder.
Assemble the Cylinder Head.
Assemble the Cylinder Cowling.
Assemble the Spark Plug.
Assemble the Ignition Coil.
7. Assemble the Oil Pump Driven Gear.
Assemble the Oil Pump Assy.
8. Assemble the Reed Valve.
Assemble the In-take Pipe Assy.

4-3-3 Assembly Sequence of Engine

9. Assemble the Pinion Gear Assy.
Assemble the Starting Gear.
Assemble the Cap Set of Starter Idler Gear.
Assemble the Starting Motor.
10. Assemble the Coil Assy.
Assemble the Flywheel Magneto.
Tighten the Nut of Flywheel Magneto.
11. Assemble the Fan Case.
Assemble the Air Cleaner.
Assemble the Cooling Fan.
Assemble the Fan Cowling.
Assemble the Muffler.
12. Assemble the Oil Seal of Movable Driven Face Comp.
Assemble the O-Ring.
Assemble the Ball Bearing of Fixed Driven Face Comp.
Assemble the C Type Cir-clip.
Assemble the Needle Roller Bearing.
Assemble the Fixed Driven Face Comp.
Assemble the Roller Pin.
Assemble the Spring Sheet.
Assemble the Spring.
Assemble Clutch Assy.
Tighten Nut of Driven Pulley Assy.
Assemble the Driven Pulley Assy.
Assemble the Clutch Housing.
Assemble the Nut of Clutch Housing Comp.
13. Assemble the O-Ring of Movable Drive Face Comp.
Assemble the Guide Block.
Assemble the Roller Set.
Assemble the Movable Drive Plate.
Assemble the Cover
Assemble the Spacer.
Assemble the Movable Drive Face Comp.
Assemble the Kick RH Starter.
Assemble the Kick LH Starter.
Assemble the Washer.
Assemble the Spring Holder.
14. Assemble the Kick Starter Shaft Assy.
Assemble the Spring.
Assemble the Clutch Cover.
Assemble the Kick Starter Lever Assy.

Remark:" "means that special tools are needed.

4-3-3 Assembly of Engine:

1.Assembly of Crank Case

A. Assemble the front Bush (1) of crank case with a vice.

The knurled side of Bush should face inwards when installing the buffer into the LH and RH crank cases.

Extrude **1.5mm** to both sides when installing the Bush into the lug of crank case.

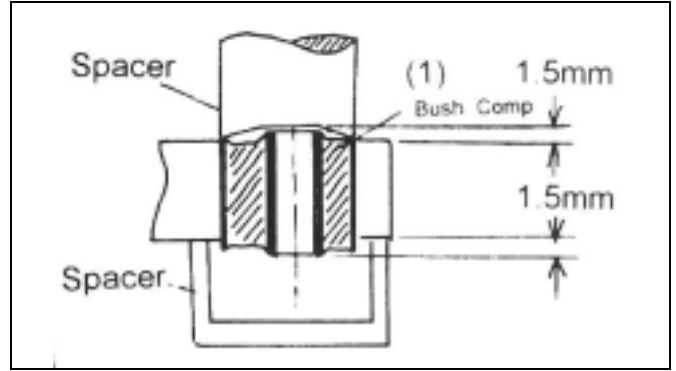

B. Assemble the Bush (2) of rear shock absorber of left crank case with sleeve and vice.

Extrude **3.0mm** to both sides when installing the bush into the rear lug of crank case.

The size of Spacer pressed into the Bush should be a little less the exterior diameter of outer ring of Bush. The Spacer must be pressed onto the outer ring, not the inner ring.

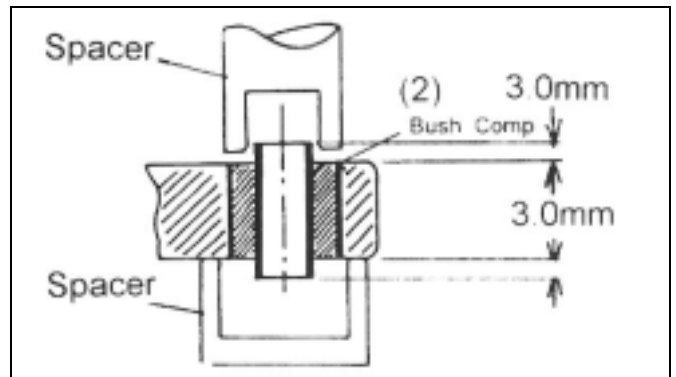

C. Apply a thin layer of grease GA50400005 onto the lip of oil seal of the right hand crank case and install the oil seal (3) with special tool.

Special Tool: GA5000051F30

Slanting of oil seal and damage to the lip when press fitted shall not be allowed.

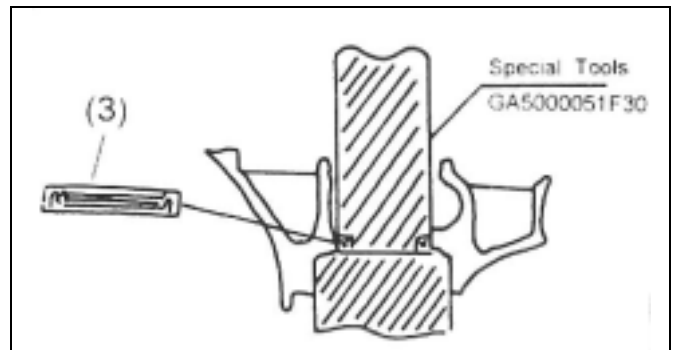

D. Add about 0.3cc of engine oil (JASO FC)

(GA50400002) into the bearing(4) of right hand crank shaft and press the bearing into the right hand crank case with special tool.

Special Tool: GA5000051F16

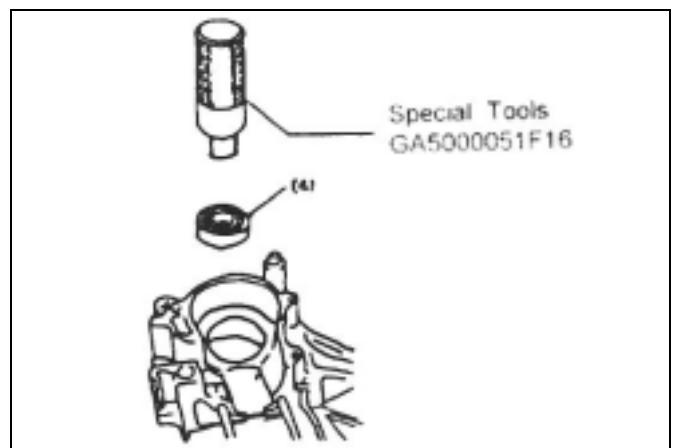

4-3-3 Assembly of Engine:

E. Apply a thin layer of grease GA50400005 onto the lip of oil seal of the left hand crank case and install the oil seal with special tool.

Special Tool: GA5000051F32

Slanting of oil seal and damage to the lip shall not be allowed.

F. Add about 0.3cc of engine oil (GA50400002) into the bearing(I) of left hand crank shaft and press the bearing into the left hand crank case with special tool.

Special Tool: GA5000051F15

G. Apply about 0.3cc of engine oil on the bigger end of Con-Rod of Crank Shaft, Draw the Crank Shaft(2) into the Right Hand Crankcase (3) with special tool.

Special Tool: GA5000051F08

Avoid damage to the Lip of Oil Seal while drawing in.

Knocking on the crank shaft is not allowed and dust and dirt into the crank chamber should be avoided.

H. Apply seal agent (GA50400001) evenly to the contact surface of RH and LH crank cases.

Do not apply too thick.

Avoid entering of seal agent into joints and the crank chamber.

I. Install knock-pin.

J. Assemble RH crank case (3) and LH crank case(4).

Avoid damage and overturning of the Lip of oil Seal.

K. Tighten the crank case screw.

Screw Torque: 50~80 kg-cm

Try to see if the operation of crank shaft is smooth.

L. Apply about 10cc of grease (GA50400005) onto the oil-pump driven gear's chamber of crank case.

M. Insert the oil-pump driven gear(5).

N. Press in the oil seal (6)of oil-pump driven gear with special tool.

Special Tool: GA5000051F31

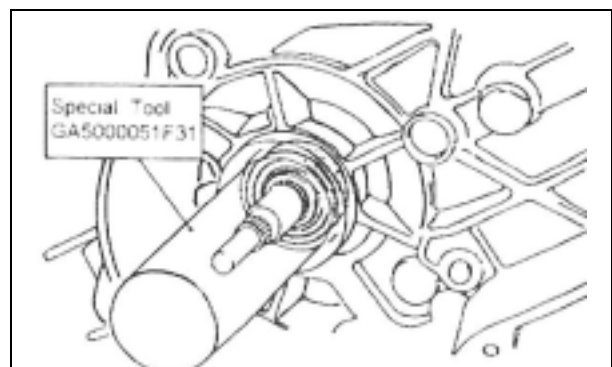
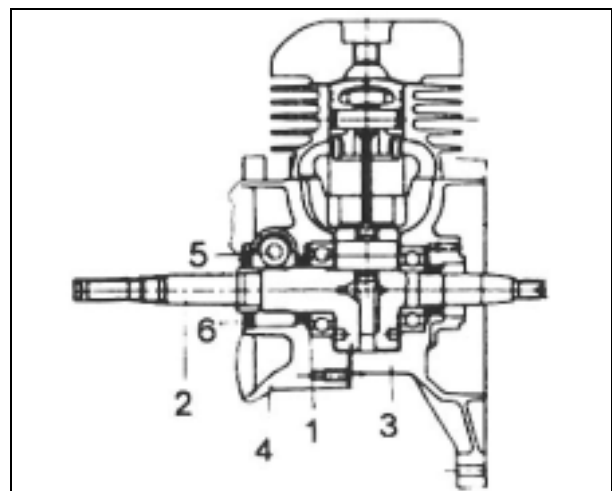
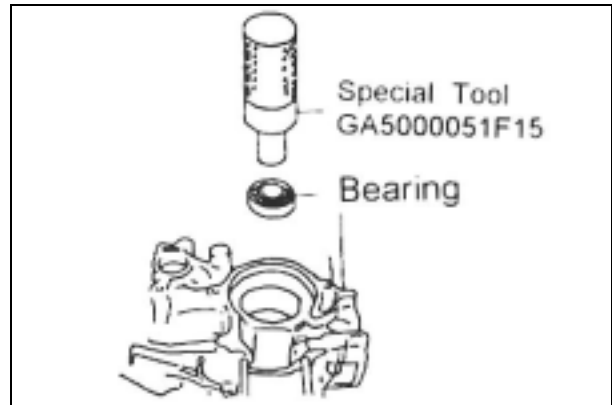

4-3-3 Assembly of Engine:

2. Assembly of Center Stand

- A. Install Center Stand (1).
- B. Insert the shaft (2) of center stand.
- C. Install washer (3) and cotter pin (4)
- D. Hook the spring of center stand to the bolt of crank case.

3. Assembly of Rear Wheel

- A. Apply a layer of grease (GA50400005) onto the lip of oil seal of Rear Axle and press into the left hand crank case with special tool.
Special Tool: GA5000051F33
- B. Punch in the right bearing of rear axle with special tool.
Special Tool: GA5000051F16.
- C. Install the bearing retainer (18) and lock the screw.
Screw Torque: 120-130 kg-cm
- D. Apply a little gear oil (GA50400004) to the rear axle and press into the reducing gear chamber of the crank case.
- E. Apply a little grease (GA50400005) to the shaft (1) of the Cam of rear brake and then install into the crank case.
- F. Tighten the cam bolt (2) and cam lever (3) of rear brake.
Screw Torque: 60 90 kg cm
- G. Apply a thin layer of grease (GA50400005) to the cam of rear brake.
- H. Hook the spring (4) and then inlay the rear brake lining (5).
- I. Install rear wheel (6).
- J. Tighten rear wheel nut (7) and washer (8)
Screw Torque: 600-900 kg.cm

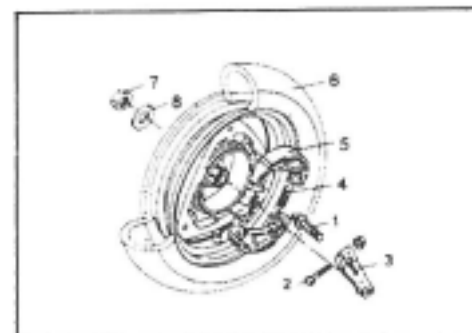
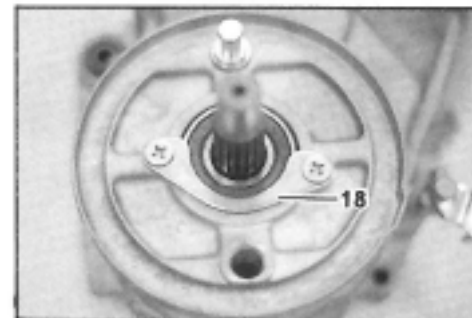
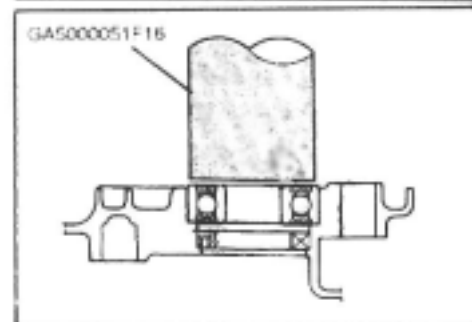
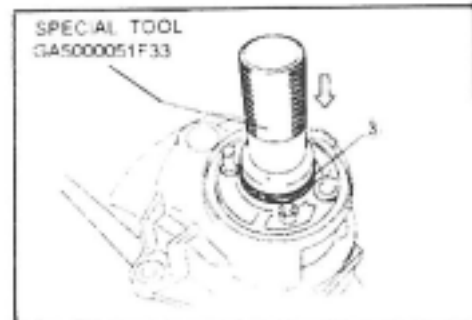
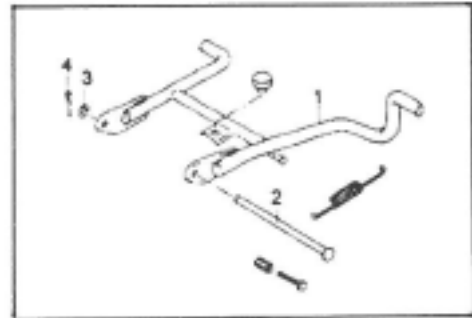

4-3-3 Assembly of Engine:

4.Assembly of Reducing Gear

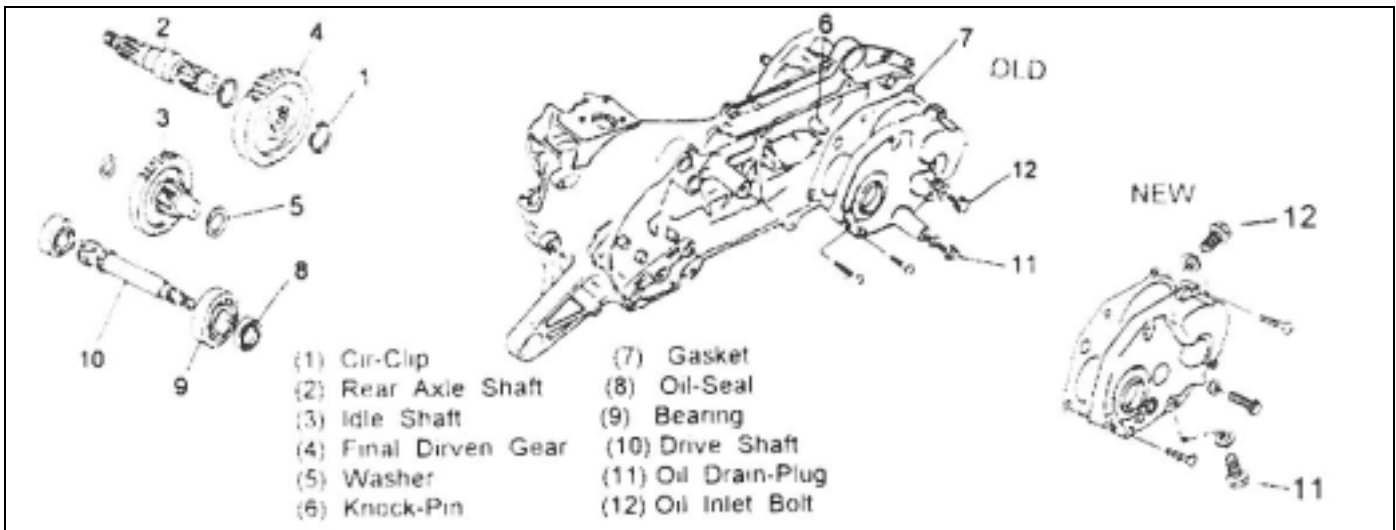

A. Apply a little gear oil (GA50400004) on the right hand bearing of rear axle, and then evenly press into the reducing gear chamber. with fixture.

Special Tool: GA5000051F18.

B . Mount cir-clip (1) on the rear axle(2).

C. Install idle shaft washer(5).

D. Apply a little gear oil (GA50400004) on the bearing contact surface of idle shaft.

E. Install the final driven gear(4). Install cir-clip of rear axle.

F. Install idle shaft washer(5). Install idle shaft (3)

G. Assemble knock-pin(6) .

H. Install the gasket(7) of gear box cover.

I. Apply grease (GA50400005) on the lip of oil seal(8) of drive shaft and then press into the gear box cover with special tool.

Avoid damage to the lip of oil seal. Install horizontally and slanting is not allowed.

Special Tool: GA5000051F30

J. Press in the LH bearing (9)of drive shaft with special tool.

Special Tool: GA5000051F17

K. Press the drive shaft(10) evenly into the gear box cover. .

L. Install the gear box cover and lock the bolt in sequence by diagonal step.

M. Lock the drain bolt(11) .

Screw Torque : 90 - 150 kg cm

The drain hole for engine is located on the gear box cover or outside the crank case, for we have two designs.

N. Fill 90cc of TGB gear oil (GA50400004)

Q. Tighten the refilling bolt(12).

Screw Torque : 90 kg cm

The refilling hole for engine is located on the gear box cover or outside the crank case,for we have two designs.

4-3-3 Assembly of Engine

5. Assembly of Piston

A. Apply TGB oil (GA50400002) on the needle roller bearing at the small end of con-rod.

B. Install the piston ring (3) on the piston (2). (FOR 50C.C.)

a. The 2nd ring (6) is engraved 2R mark which should face upwards while installing. Put the expansion ring (8) insert into the piston first, and then install the 2nd ring.

b. There is a cone surface on the 1st ring (7), place the engraved surface with R mark upwards while installing.

The opening of piston ring should point to the knock-pin(9)of piston while installing.

Do not put too much force while open to let the piston through, so that the piston ring will not be damaged.

For 90C.C. engine, there are two cone piston Rings without expansion ring.

C. Install the cir-clip (5) of piston pin into the cir-clip groove of piston. The cir-clip has to be actually installed into the groove, or it will cause cylinder jam during operation.

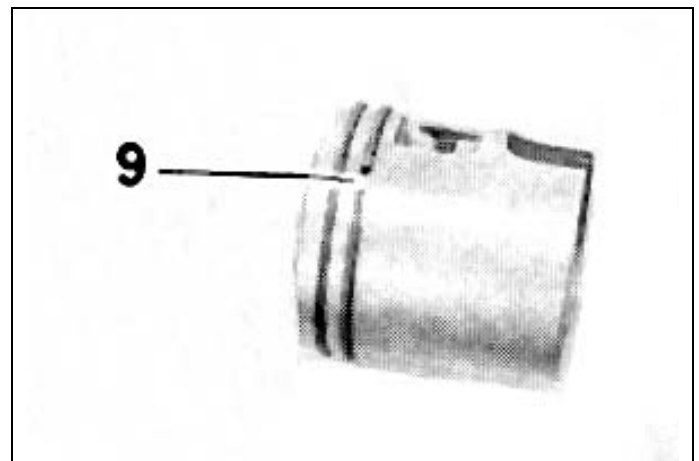
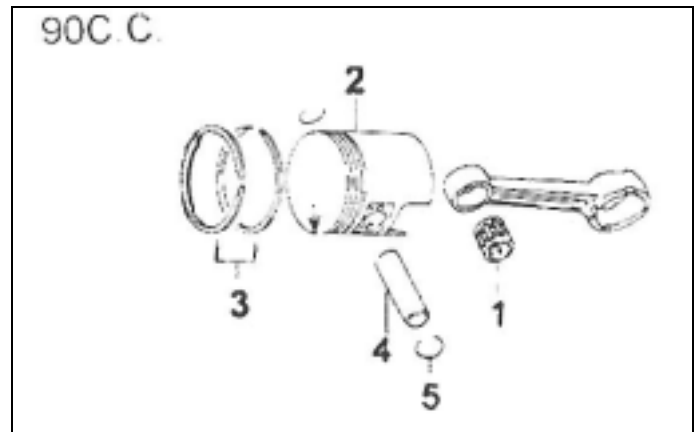
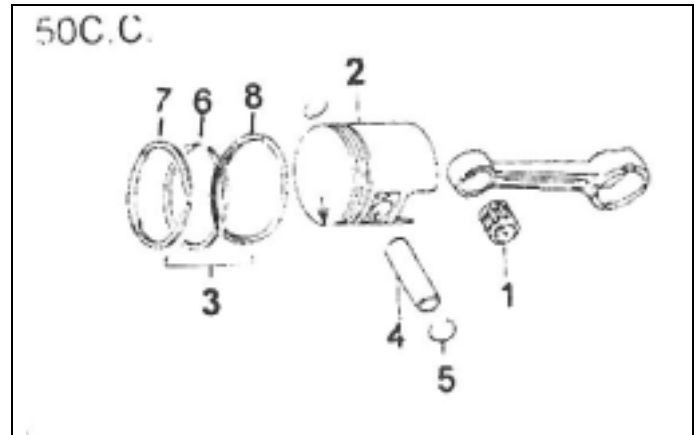

4-3-3 Assembly of Engine:

6. Assembly of Cylinder:

- A. Apply a little TGB oil. (GA50400002) to piston pin (3) and then insert into the piston hole.
- B. Install the cir-clip (4) of piston pin and make sure to rotate the opening of the circlip to be kept away from the concave area of the piston.

The cir-clip has to be actually installed to its position, or it will cause cylinder jam during operation.

- C. Apply more than 3cc of TGB oil (GA50400002) evenly on the inside of the cylinder and the outside of the piston.
- D. Install cylinder gasket (2).
- E. Install piston (1) into cylinder.

The arrow mark on the piston has to be install toward the exhaust port.

- F. Install cylinder head gasket .
- G. Install cylinder head (6).
- H. Screw the flanged nut (7) of cylinder head by diagonal step.
Screw Torque: 120 130 kg cm
- I. Install the cylinder cowling (9).
- J. Tighten the spark plug (8).

Screw Torque: 250 300 kg cm

- K. Point the extruded part of ignition coil to the groove of cylinder cowling and then tighten the screw.

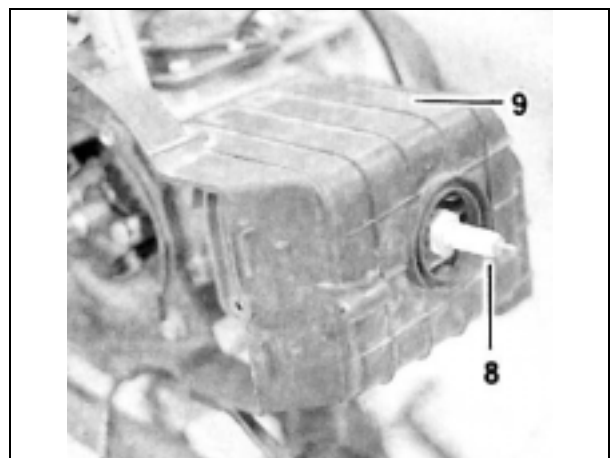
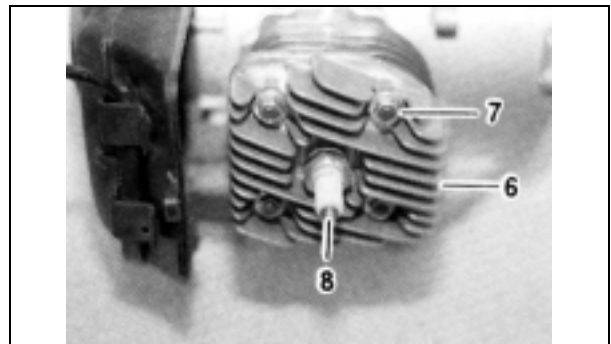
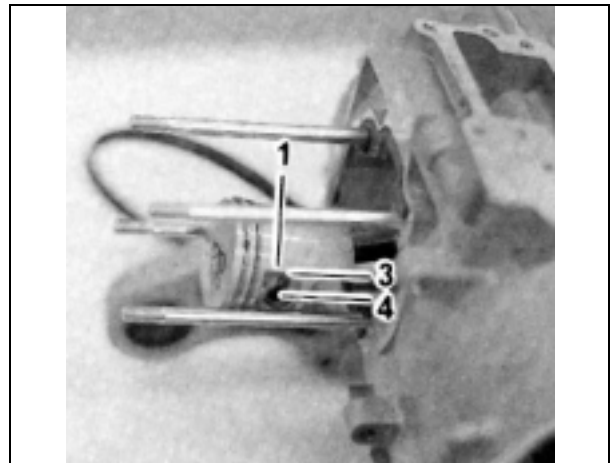
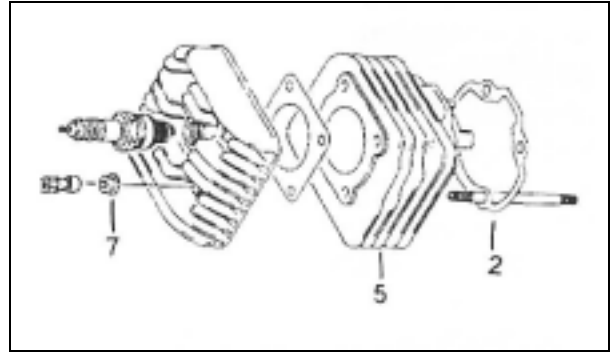

4-3-3 Assembly of Engine:

7. Assembly of Oil-Pump:

- A. Apply a layer of grease (GA50400005) on the sliding part and gear tooth of oil-pump driven gear (1) and then insert into the crank case.
- B. Install the oil-pump (2).

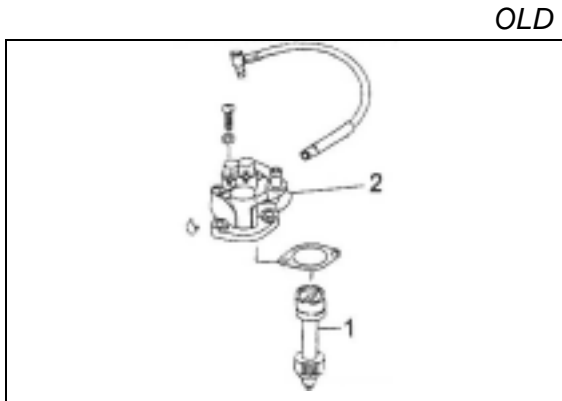

8. Assembly of Reed Valve:

- A. Install the reed valve (5) on the in-take pipe.
- B. Install the gasket (6) and the in-take pipe (4) into the crank case.
- C. Screw the fender bracket (7) on the in-take pipe.

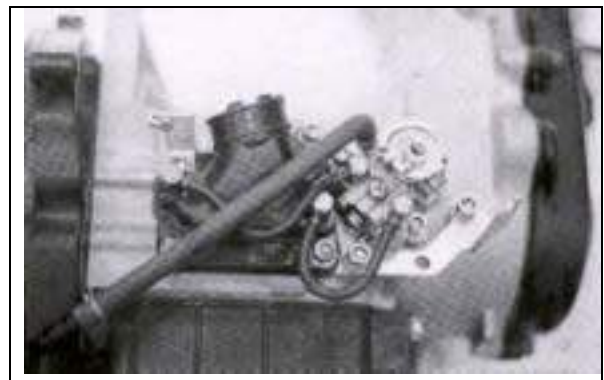
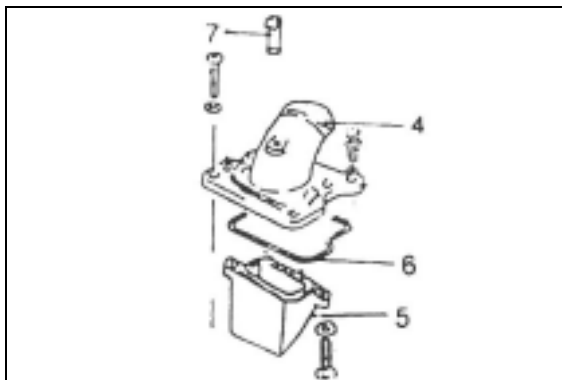

9. Assembly of Starter Motor:

- A. Apply a thin layer of grease (GA50400004) on the shaft of pinion gear assy and then install into the crank case.
- B. Install two knock-pins (9).
- C. Install starter idle gear cap (10) and screw (3)

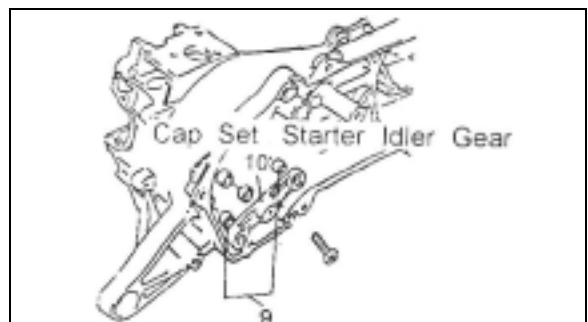
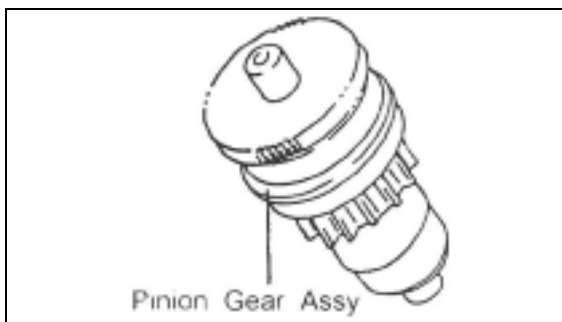

4-3-3 Assembly of Engine:

D. Install the starter gear(l) into the left hand crank shaft(2).

E. Install the starter motor and tight the bolt with cable clamp.

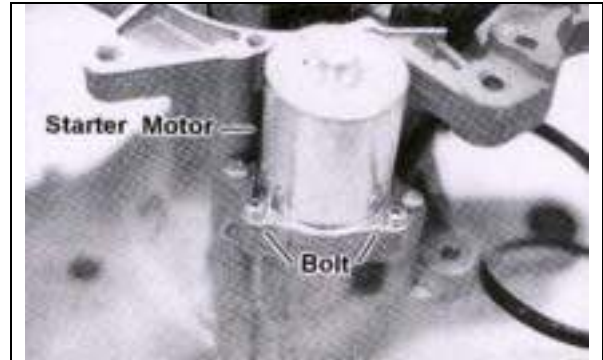
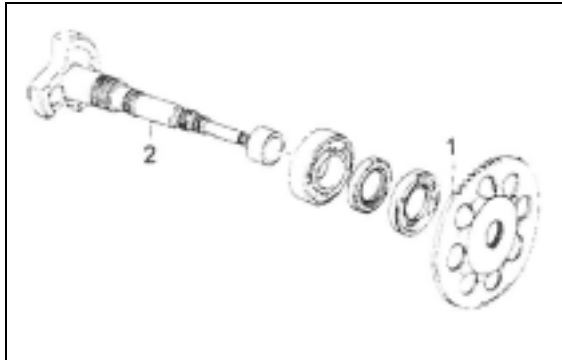

4-3-3 Assembly of Engine:

10. Assembly of Flywheel Magneto

A. Screw the coil.

B. Let the coil lead go through the opening of Crank Case.

C. Install pick-up (1)

D. Clean the taper of crank shaft and install the key .
Tap lightly to its position.

E. Install the flywheel magneto.
Avoid the drop of key and make sure to the position of the flywheel magneto.

F. Use tool to avoid the turning of flywheel magneto.

Special Tool: GA5000051F04

Screw Torque:350~450 kg.cm



OLD



NEW

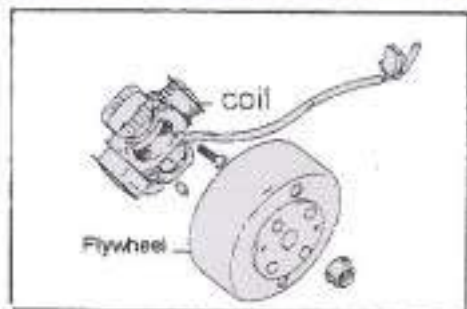

OLD

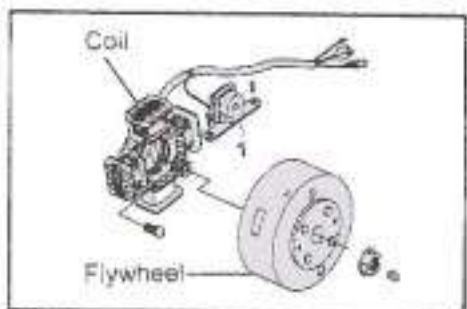

NEW



Special Tool GA5000051F04

4-3-3 Assembly of Engine:

11. Assembly of Cooling Fan:

- A. Install fan case(1) .
The lead has to go through the groove of right hand crank case and damage should be avoided.
- B. Install cooling fan(2).
- C. Install fan cowling(3) .
The starter motor and flywheel magneto lead (4) have to be installed into the lead groove, as shown.

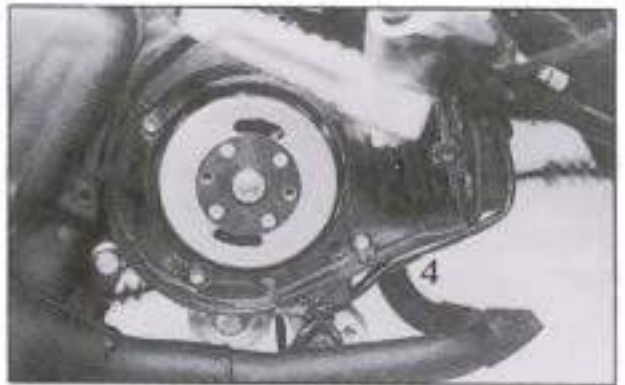
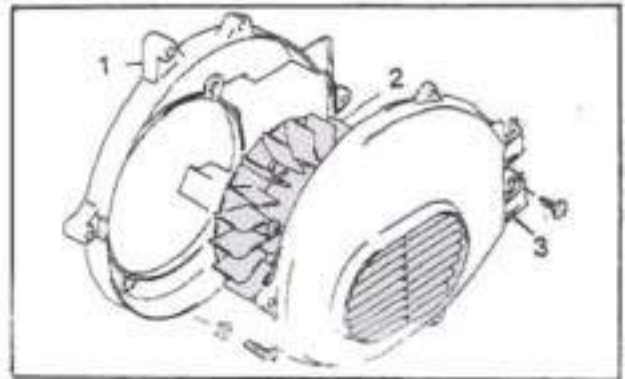

4-3-3 Assembly of Engine :

12. Assembly of Movable Driven Pulley Assy :

A. Install the ball bearing(1) into the fixed driven face comp(2).

The outer diameter of bearing press fitted with the hole of face comp.

Pay attention to press to the outer ring by special tool.

B. Install C-type cir-clip(3).

C. Install the needle roller bearing(4) .

D. Apply grease (GA50400003) on the lip of oil seal (5) and press in the movable driven face comp (6), one for top and bottom each.

E. Install the fixed driven face comp(2).into the movable driven face comp(6).

Avoid damage to the lip of oil seal.

F. Install three roller guide pins(7).

G. Install two O-rings (8) .

H. Apply about 5g of grease (GA50400005) to the groove of the Cam.

I. Apply a little grease (GA50400005) to the inside of spring sheet and manually push the spring sheet in lightly.

J. Install the spring .

K Press the clutch shoe assy with both hands, and then screwing the nut (9) with one hand still pressing the clutch shoe assy .

L .Use tool to tighten the nut of clutch shoe assy.

Screw Torque: 400~600 kg . cm

Special Tool: GA5000051F04

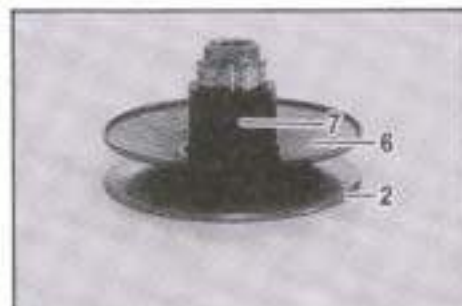
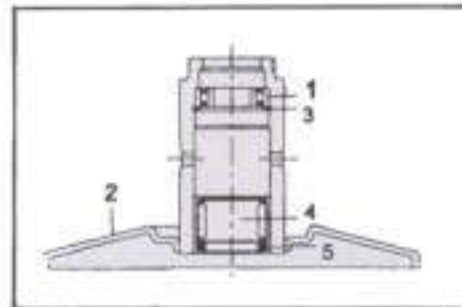

4-3-3 Assembly of Engine: (Assembly of Movable Driven Pulley Assy)

M. Move the movable driven face (1) of movable driven pulley assy towards the clutch (2) by hand. Install V-belt and then install to the drive shaft.

Wipe cleanly the grease on belt surface and the pulley surface.

N. Install the clutch housing(3).

Remove all grease inside the clutch housing and lining surface.

O. Screw the nut (4) of clutch housing with tool to stop turning or use pneumatic wrench.

screw Torque:400~600 kg . cm

special Tool: GA5000051F04

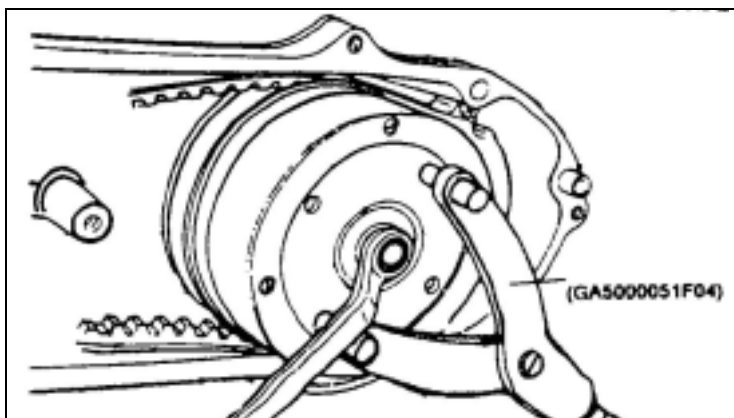
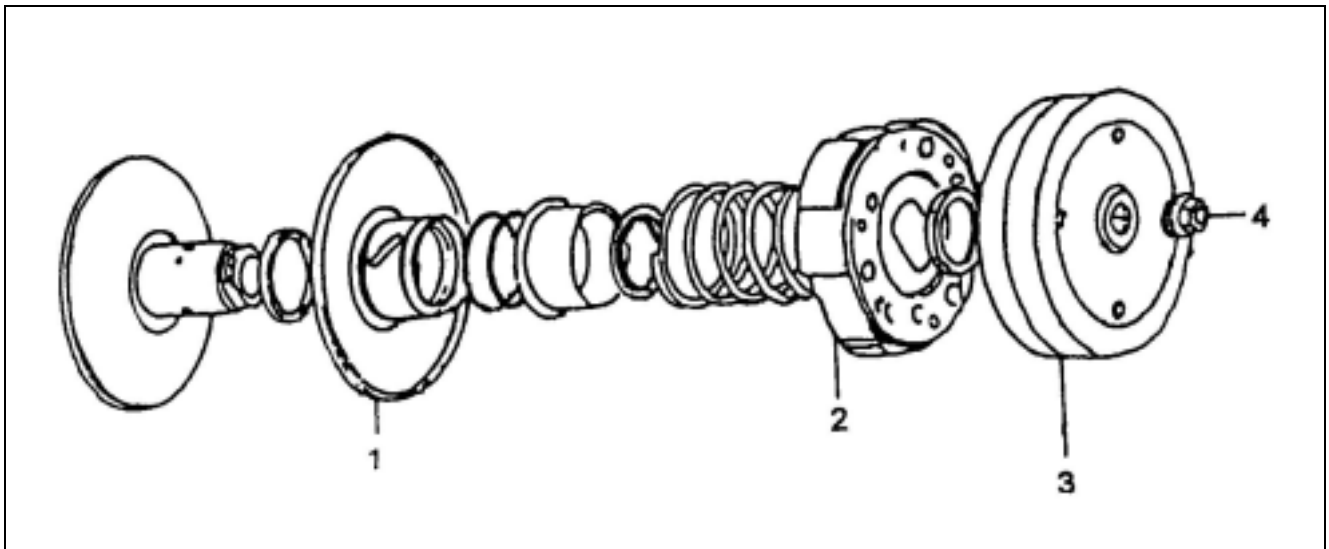

4-3-3 Assembly of Engine:

12. Assembly of Drive Pulley Assy

A. Apply about 3 ~ 4g of grease (GA50400008) to the roller groove of drive pulley and then install the roller assy into the groove.

B. Inlay the guide block (1) into the movable drive plate(2) and then install the movable drive plate(2) into the movable drive face comp(7) .

C. Install the O-ring (3) and the the cover (4).

D. Tighten the screw (5).
Press the movable drive plate all the time while installing, or the roller will turn to stand up and requiring re-adjustment .

E. Apply a thin layer of grease (GA50400008) to the hole of movable drive face comp and then inserted by the spacer (6).

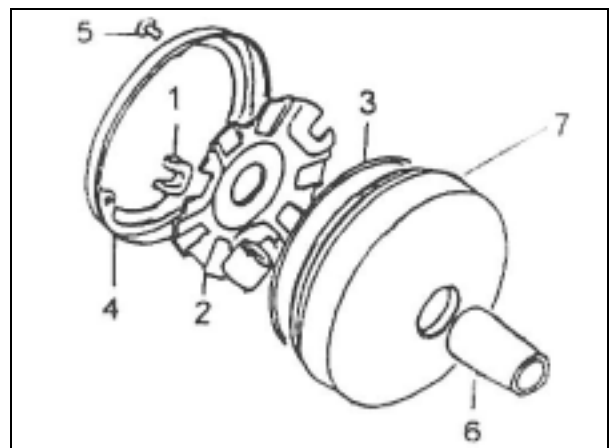
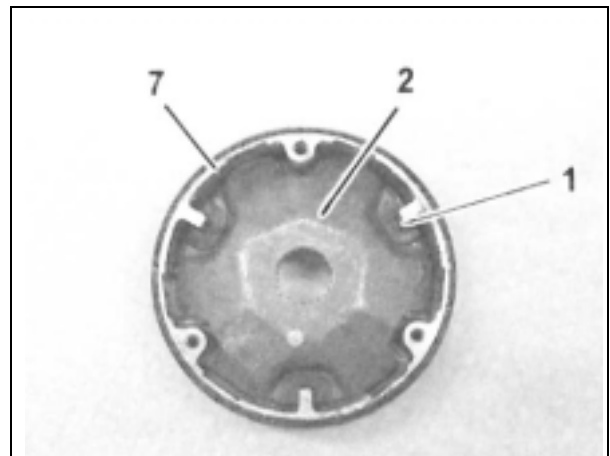

4-3-3 Assembly of Engine: (Assembly of Movable Driven Pulley Assy)

F. Clean the grease on the surface of drive pulley and then install into the left hand crank shaft.

Press the movable drive plate with fingers all the time while installing, or the roller will stand up.

G. Install the fixed drive face(1).

H. Tighten the right hand starter(2).

screw Torque:400~600 kg. cm

*** WARNING ***

Special deep socket sleeve should be adopted while screwing.

*** WARNING ***

This component is left hand threaded, thus turning counterclockwise to screw will be necessary when assemble. Use general sleeve or trying too hard to tighten will cause damage to the thread of left hand crank shaft which will cause to the replacement of crank shaft assy.

special Tool: GA5000051F36

I . Install the left hand starter (3) .

J . Install the washer(4) .

K. Install the spring (5).

L. Install the spring holder(6).

M. Tighten the screw(7).

N. Rotate the fixed drive face lightly to ensure a smooth joint for V-belt.

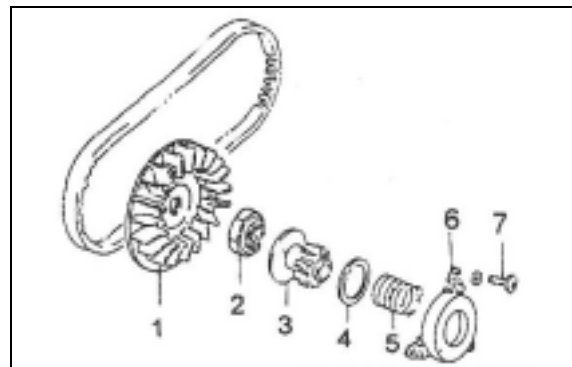

4.3.3 Assembly of Engine:

14. Assembly Kick starter Lever Assy.

- A. Apply a layer of grease(GA50400005) inside the bush(1) and then press into the clutch cover.
- B. Apply a thin layer of grease(GA50400005) to the kick starter shaft(2) and then install the spring (3).
- C. Hook the claw of spring to the hook (4) of clutch cover.
- D. Install two knock-pins.
- E. Install gasket and washer of clutch cover.

The gasket and washer are made into two sizes: **0.5mm** and **1.5mm** thick-Choose according to the original thickness.

- F. Install the clutch cover and screw the mounting screw by diagonal step.
- G. Install the kick starter lever (5) and screw the bolt .

screw Torque: 80~120 kg . cm

The kick starter lever and the horizontal line of clutch cover should form an angle of 15 degrees downward.

15. Assembly of Muffler

- A. Install the muffler (6),Put on the bolt (8) and nut first.
- B. Screw the bracket bolt (7)of Exhaust pipe.
screw Torque: 180~280 kg.cm
- C. Tighten the bolt (8) and nut of muffler.
screw Torque: 80~120 kg . cm

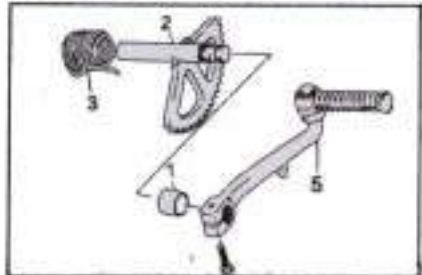
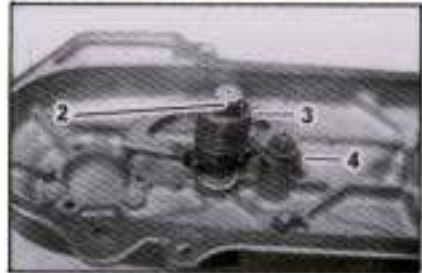
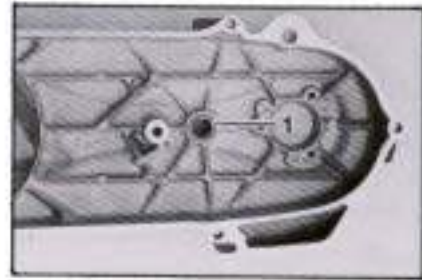

4-4 REMOVAL AND ASSEMBLY OF CARBURETOR :

Removal of Carburetor :

I. Removal of Carburetor :

- A. Remove the right hand side cover.
- B. Remove the air cleaner.
- C. Remove the fuel-hose (1).
- D. Remove the negative pressure hose (2).
- E. Remove the carburetor cap(3) and piston valve(4).
- F. Remove the auto-choke terminal (5) .
- H. Remove the carburetor.

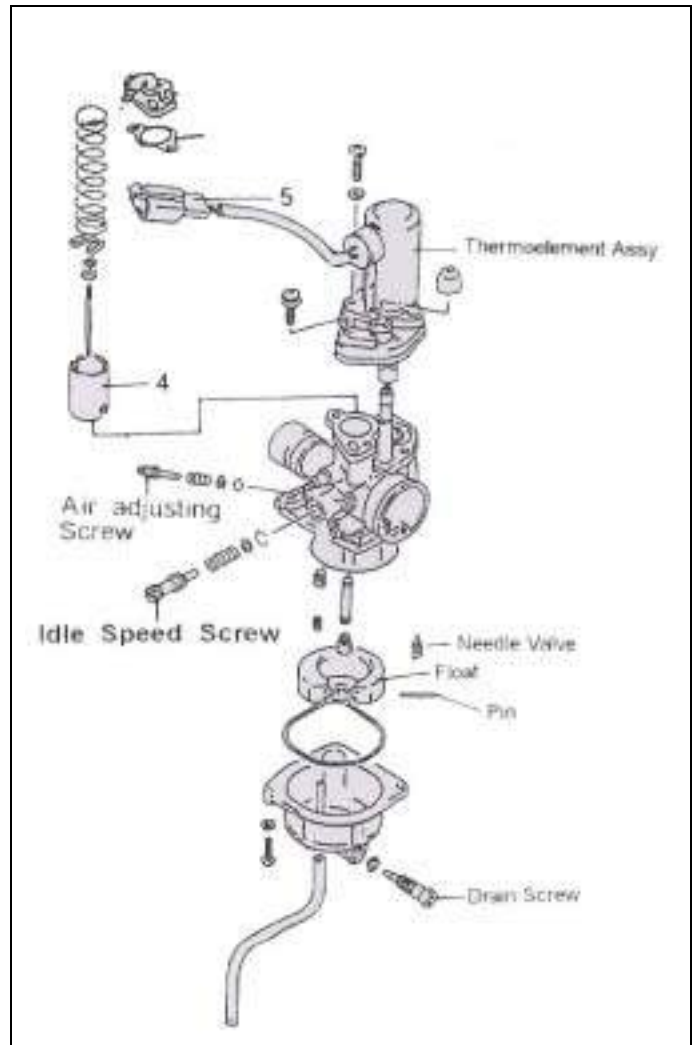

4-4 REMOVAL AND ASSEMBLY OF CARBURETOR: Inspection and Assembly of Carburetor

2. Inspection of Carburetor:

- A. Inspect and clean the jets and airway of the carburetor.
Cleaning by compressed air.
- B. Check if the float operates normally to its position.
- C. It is forbidden to use metal to remove dirt appearing on the surface, or it will cause damage to the surface. Blow the dirt off by compressed air.
Replace it if necessary .

D. Idle Setting With An Air-Adjusting Screw

Check that the throttle cable has about 1mm free play when the position valve (4) is fully closed. Always adjust the idle setting with the engine fully warm. Screw in the idle-speed screw (2) to obtain a slightly-higher idling speed than normal ; then adjust the air-adjusting screw (1) to obtain the most even running. Then unscrew the idle-speed screw again until you obtain the normal idling speed. Finally, to obtain the best engine running, it is worth rechecking by very carefully readjusting the air-adjusting screw.

3. Assembly of Carburetor :

- A. Install o-ring, washer and spring.
Screwing too hard shall not be allowed, or it will damage the seat.
- B. Install the idle speed screw (2) and spring .
- C. Install the auto-choke.
- D. Place the needle clip(3) at the 3rd groove of jet needle.
Put into the piston valve (4) with clamp (5), and press into their positions.
- E. Install the throttle cable and spring.
- F. Install the piston valve into the carburetor according to the position of groove and fix the cap.
- G. Install the carburetor into the engine.
- H. Connect the negative pressure hose and fuel-hose.
- I. Insert the terminal of auto- choke to the cable connector.

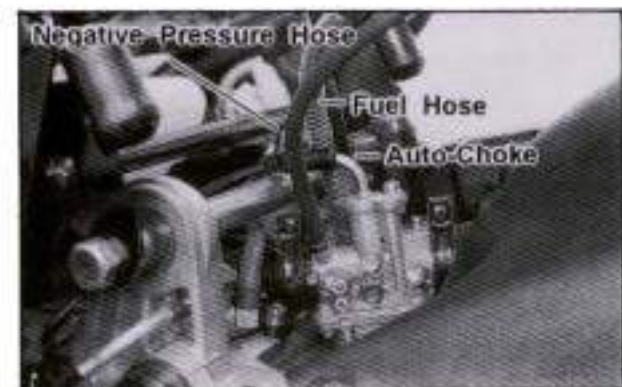
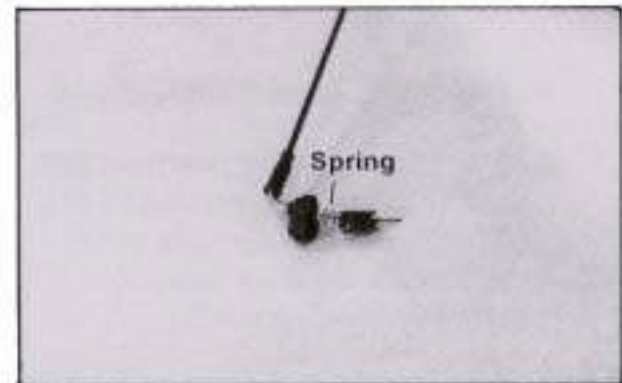
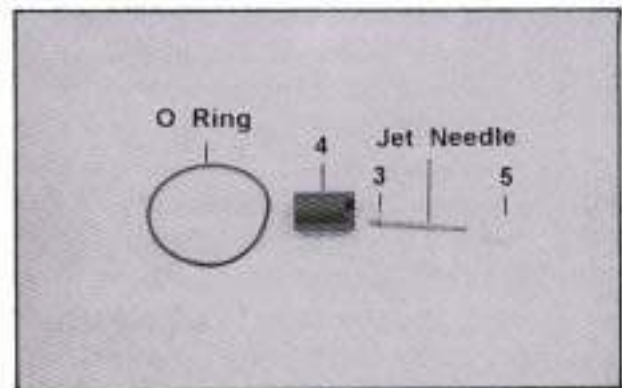
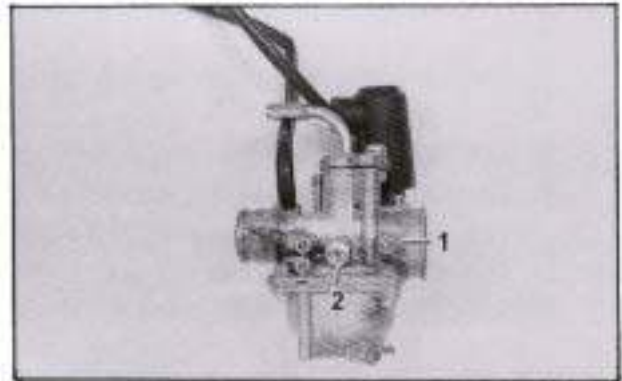

4-5 INSPECTION OF ELECTRIC ITEMS

Notice for Inspection and Arrangement of Electric Components:

- A. Use pocket tester for inspection and testing of electric parts.
- B. The battery for Testing should be of full charging.
- C. The setting of the position of Tester Range has to be performed accurately.
- D. **The value of electric testing will vary in accordance with the Tester and the temperature, thus it should be an estimate value only.**

4-5-I Removal and Inspection of Ignition and Charging System

1. Ignition and Charging Circuit:

A. Figure 1 Circuit Description:

With regard to the generation of the flywheel magneto :

- a. CDI and HTcoil (ignition coil) are adopted to control the ignition and angle for high voltage parts :
- b. Regulating rectifier is adopted to supply and control lamp and charging voltage for low voltage parts.

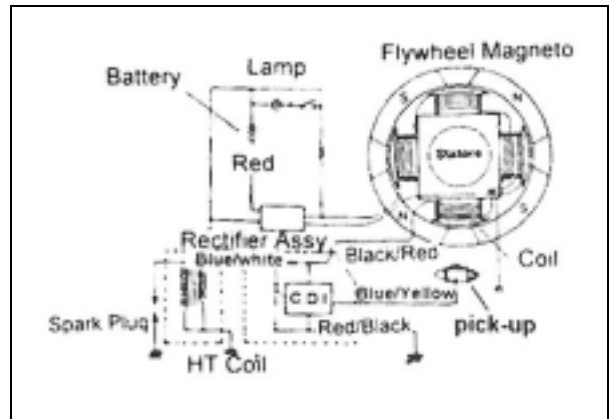

B. Inspection of Ignition Coil and

C.D.I. :

- a. C.D.I.(CAPACITOR DISCHARGE IGNITION) bullet type terminal(1) is for Flywheel Magneto's input, red/black Wire is for ground and white/blue Wire is for output at terminal(2).

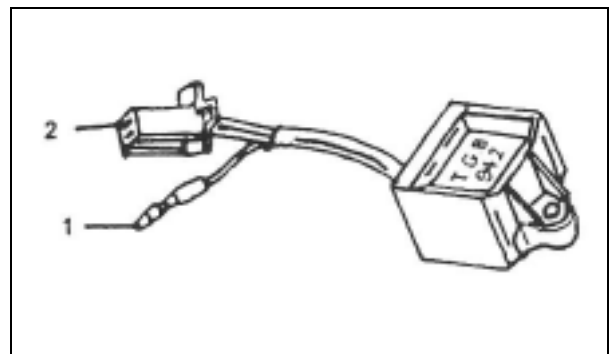

Ignition angle's standard is **15°/4000 RPM**

Ignition coil (Fig. 3) testing range **X 1 K**

Use electric tester to check resistance value (Fig.3), must fit to "**8K ± 10 %**"

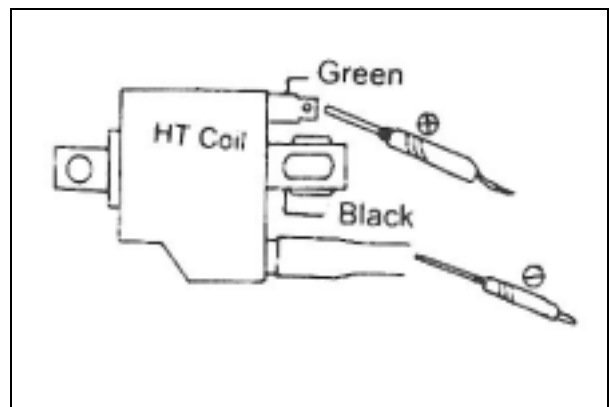

4-5-1 Removal and Inspection of Ignition and Charging System

C. Inspection of Rectifier

- a. Testing Range - X 1 K
- b. Terminals shall not connect with the rectifier surface.
- c. Check the electric resistance value between each wire.

Electric Resistance of Rectifier				
Red Black	White/ Red	Yellow/ White	Red	Black/ White
White/Red				
Yellow/White				5~100K
Red				
Black/White		5~100K		

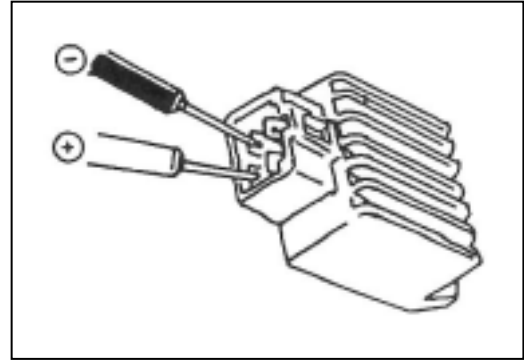

D. Inspection of Coil Assy.

- a. Test the electric resistance value between each wire.
- b. Testing Range - X I K

Electric Resistance of Coil Assy			
Tester Connect to Wire		Electric Resistance	
Red ⊗	Black		
Yellow/White	Ground	Lamp	0.76 ± 20 %
White/Red	Ground	Charge	0.97 ± 20 %
Black/Red	Ground	High Voltage	224 ± 20 %

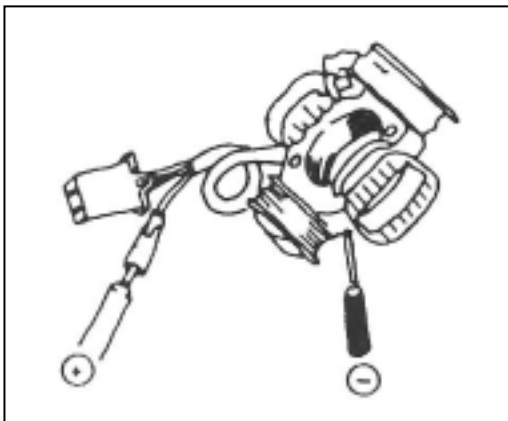

4-5-1 Removal and Inspection of Ignition and Charging System

E. Inspection of Charging Voltage

- Connect the volt meter to the " + " and " - " terminals of battery .
- Range: DC V
- Keep wheel away from the ground while testing.
- Testing Methods & Conditions:
 - *Run the engine to 5000rpm.
 - * Test the voltage value when the high beam of head lamp is on.
 - * Test the voltage value when the high beam of head lamp is off.
 - * Charging Voltage: 13 15V

FOR GA



FOR GF/GI



F. Inspection of Spark Plug

- Remove the spark plug cap (Figure 2)
- Remove the spark plug.
- Check for any dirt and damage of electrode with eyes.
- Clean with special tool or wire brush if it is dirty.
- Replace spark plug if complete recovery is impossible.

FOR BH
BR
GE



G. Inspection of Spark Plug

- The gap between electrode and ground electrode should be correctly adjusted and kept between 0.6 0.7mm(For 50C.C.)
0.9~1.0mm (For 90C.C.)
- Models of Applicable Spark Plug :

50C.C.

NGK	FUNCTION
LOW HEAT TYPE	BP7HS/BPR7HS
STANDARD TYPE	BP6HS/BPR6HS
HIGH HEAT TYPE	BP5HS/BPR5HS

90C.C.

STANDARD TYPE	BP7HS-10 BPR7HS-10
---------------	-----------------------

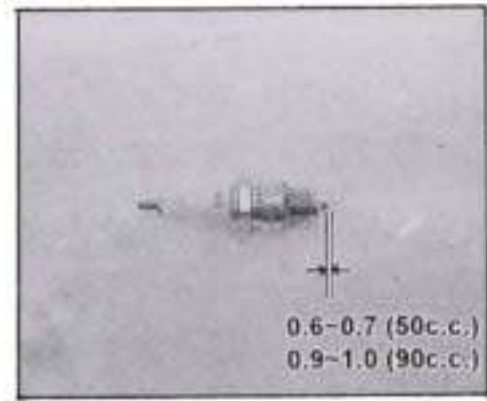

4-5-2 Removal and Inspection of Starter Mechanism

A. Circuit of Starter Mechanism:

a. Circuit Description:

Ignition Switch ON Brake Switch ON
Starter Relay Starter Switch ON
Starter Motor started.

B. Inspection of Starter Relay:

- Test the Ohmic value between each terminal of the coil. (see Figure 2)
- Set up the range as $\times 10\Omega$.
- The value of electric resistance of the starter relay must be 50 – 70 Ω , replace when value out of this range.

C. Connect the coil end with 12V

Power supply (as Figure 2), a beep sound means they are connected.

D. Inspection of Starter Motor:

- Inspect weariness and roughness of contact surface on carbon brush (1).
- Inspect the surface weariness and burning of the commutator (2).
- Measure the outside diameter of the Commutator (2).
- The commutator and the armature core (3) or shaft (4) should not be passed through between.
- Each segment and the commutator should be passed through.
- The standard length of carbon brush should be 5.5mm. Replace if it is under 3.0mm.
- The standard outside diameter of commutator should be 16mm. Replace if it is under 15.5mm.

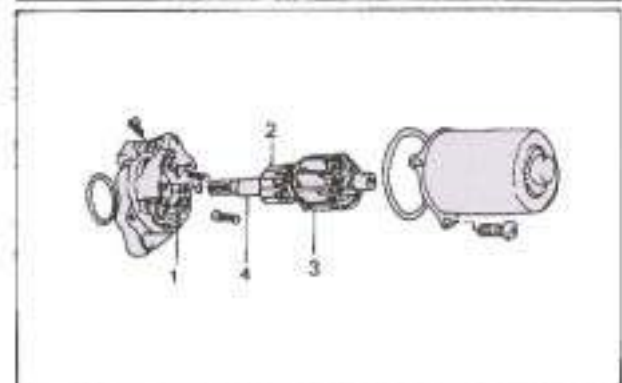
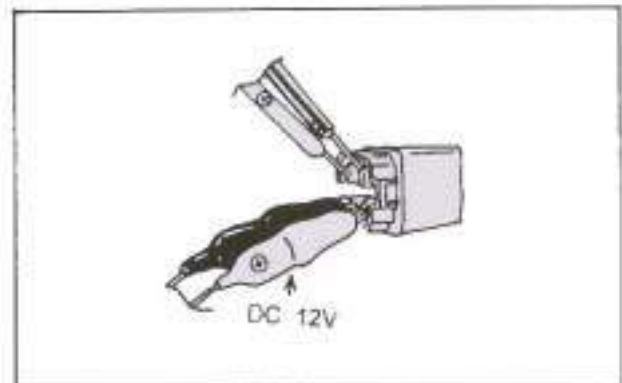
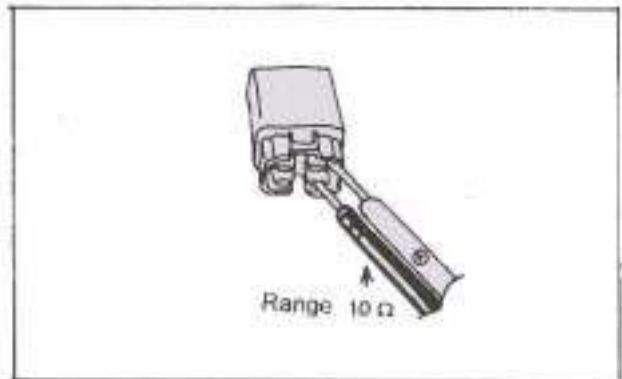
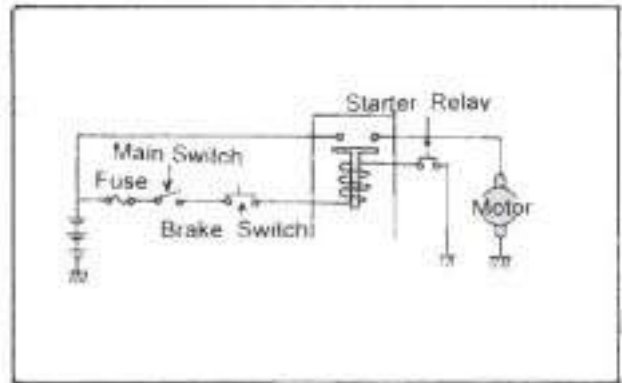

4-5-3 Removal and Inspection of Fuel Meter and Fuel Level Gage

A. Inspection of Fuel Meter :

To perform this Testing, lift the seat and remove the right hand frame cover, then disconnect the B/W and Y/B lead connector of the fuel gauge sending unit. Connect a jumper wire between B/W and Y/B wires coming from the main wiring harness. With the ignition switch turned ON, the fuel meter should indicate "F".

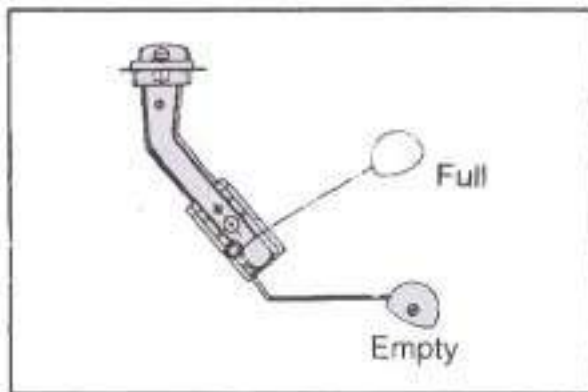

B. Inspection of Fuel Level Gage :

The relation between the position of the fuel gauge float and resistance is shown in the following table.

Float Position	Resistance
Float on Top(Full)	Approx 10
Float at Bottom (Empty)	Approx 90

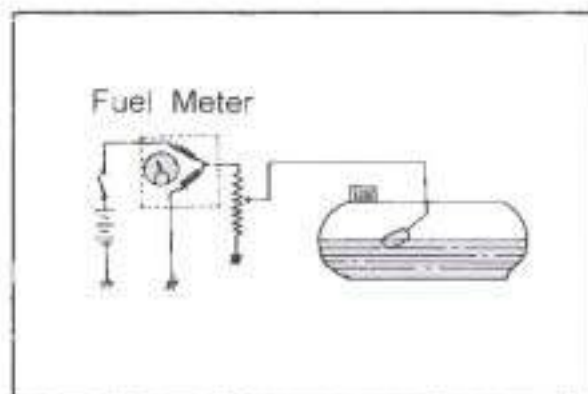
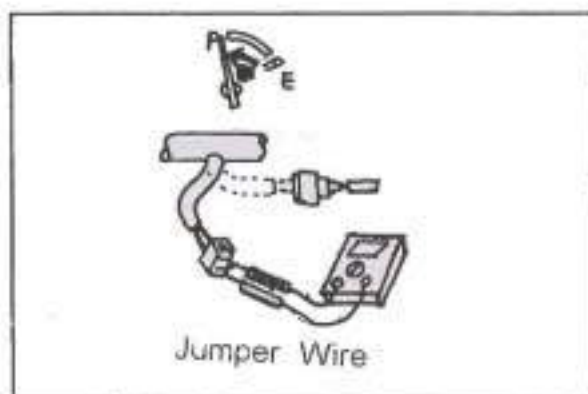

4-5-4 Removal and Inspection of Turn-Signal Indicator, Oil Warning Indicator and Level Gage

A. Circuit of Signal Light:

Ignition Switch ON Turn Signal
Relay ON Turn Signal Switch ON
Turn Signal Indicator ON .

B. Inspection of Oil Warning Lamp:

- When the ignition switch is at the position of " ." between "on" and "off", the oil warning indicator must be lit .
- When the "start" button is pressed, the oil warning indicator must be lit also.
- The indicator must be lit when the gray and brown wires are connected ; Disengage the connector of oil level gage (Figure), The indicator must be off.

C. Inspection of Oil Level Gage:

- When the float of the oil level gage lower down , it is with passing through.
- When the float of the oil level gage rises up , it is without passing through.

FOR GA5

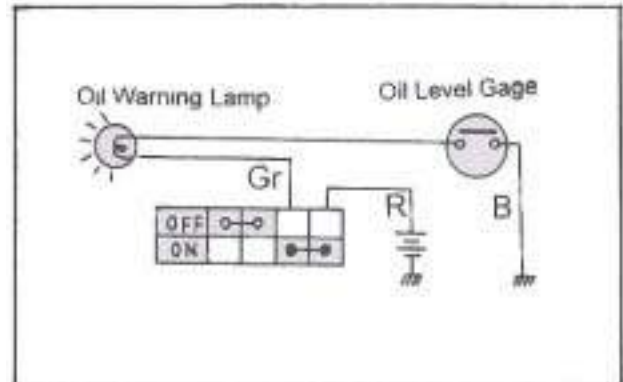

FOR THE OTHERS

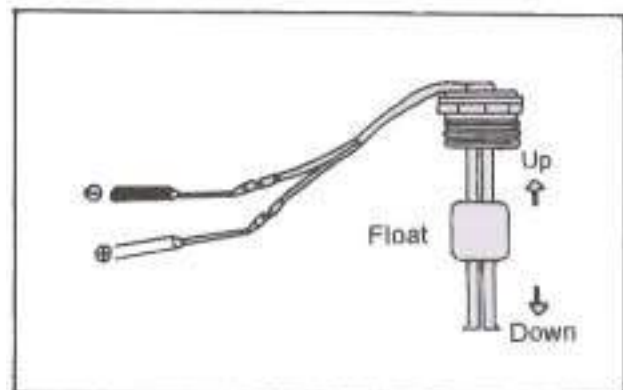
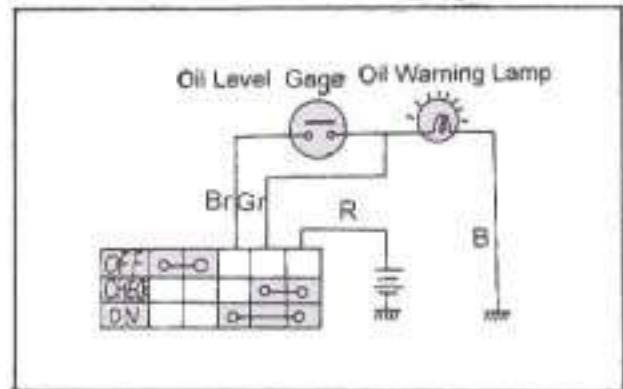

4-6 REMOVAL AND INSPECTION OF BODY PARTS

Removal and Inspection of Front Fork

4-6-1I. Removal of Front Fork

- A. Remove front-leg shield.
- B. Remove the front cover of handle.
- C. Remove the speedometer cable.
- D. Remove the brake hose(19).
- E. Remove the brake caliper(32).
- F. Remove the wheel.
- G. Remove the flange bolt (2) and hexagon socket screw(33) of handle.
- H. Release the bearing locknut(4) with a tool. Special Tool: GA5000070F01
- I. Remove the upper steering race (outer)(6).
- J. Remove the steel ball (7)of front fork mounting tube.
- K. Remove the front fork cover(34).
- L. Remove the front shock absorber(35).
- M. Remove the brake con-rod.
- N. Remove the bracket of brake lining.
- O. Remove the lower steering race(inner)(9) and upper steering race(inner)(8).
- P. Knock out the lower steering race(11) by a round bar with sharp angle.

4-6-2. Inspection of Front Fork:

- A. Check for any unusual wear of the sliding spacer.
- B. Check for any damage and wear to the oil seal of shield cover.
- C. Check for any unusual wear of front fork arms.
- D. Check for any unusual wear of brake con-rod bush.
- E. Check for any unusual wear of spacer.
- F. Check for any damage to the oil seal lip of cover and if the grease inside is dried up or lost.
- G. Check for any unusual wear of the spacer of brake lining bracket.
- H. Check for any unusual wear of the steering race.
- I. Check if the shock absorber spring is decayed or leaking oil and check for any unusual wear of between the upper and lower connecting seats.

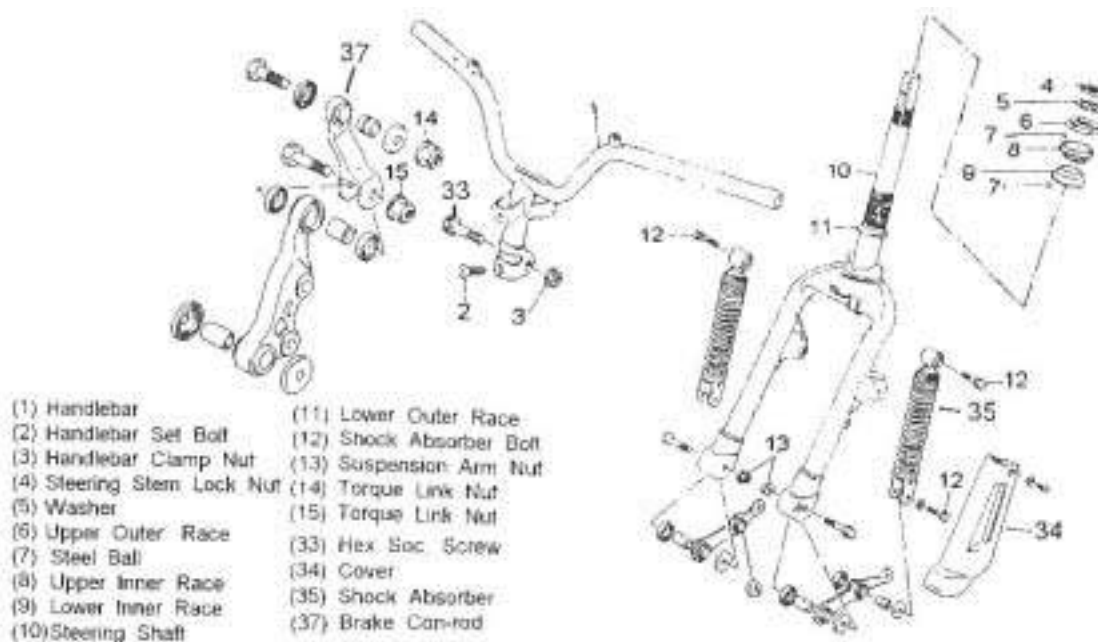

4-6 Disassembly and Inspection of Body Parts Disassembly of Brake

4-6-3 Removal and Inspection of Brake

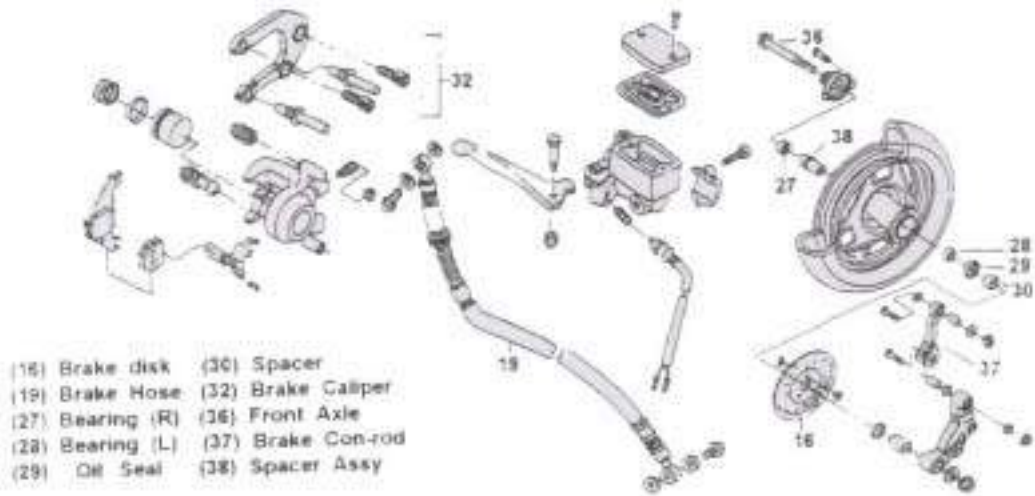

I. Disassembly of Front Brake:

- A. Remove the hose assy of brake(19), brake caliper(32), speedometer cable , front axle(36), brake con-rod(37), and brake disk(16).
- B. Remove the brake disk(16).
- C. Remove the spacer(30).
- D. Remove the oil seal(29).
- E. Remove the right hand bearing(27).
- F. Remove the left hand bearing(28).
- G. Remove the spacer assy(38).

2. Inspection of Brake Parts:(FOR Front and Rear Brake)

A. Inspection of Brake Drum:

- a. Testing the inner diameter of brake.
- b. Check for any unusual wear mark on the drum.

Inner Diameter of Brake Drum (mm)			
Standard	110	Limit	Replaced over 110.7

B. Inspection of Brake Lining :

- a. Measure the outside diameter perpendicular to the brake cam and anchor-pin on the brake lining.
 Confirm if the assembly of the brake lining is correct and if the brake cam completely returns to the original place.
- b. Check for any crack or damage on each part.
- c. Check for any grease stain on the lining.

Dimension of Brake Lining (mm)			
Standard	109.2	Limit	Replaced over 106



4-6-3 Removal and Inspection of Brake

C. Inspection of the Return Spring of Brake Lining:

- a. Testing the free length of the spring with a vernier caliper.
- b. Check for any wear and crack on the spring.

Free Length of the Return Spring of Brake Lining (mm)			
Standard	32.6-33.0	Limit	Exchanged over35.0

D. Inspection of the Brake Cam:

- a. Check for any rust or unusual wear on the brake cam.
- b. Make sure the brake cam runs smoothly.
- c. Make sure to apply sufficient grease to the brake cam and lining anchor-pin.

E. Inspection of Front Brake:

- a. Check the gap between the ends of front brake lever.

**Gap of Front Brake Lever
20 ~ 30 mm**

- b. Add brake oil.
- c. Check the brake lining.

F. Inspection of Rear Brake:

- a. Check the gap between the ends of rear brake lever.
- b. Move the adjusting nut of brake cable clockwise to proper gap.

**Gap of Rear Brake Lever
15~35 mm**

FOR REAR BRAKE

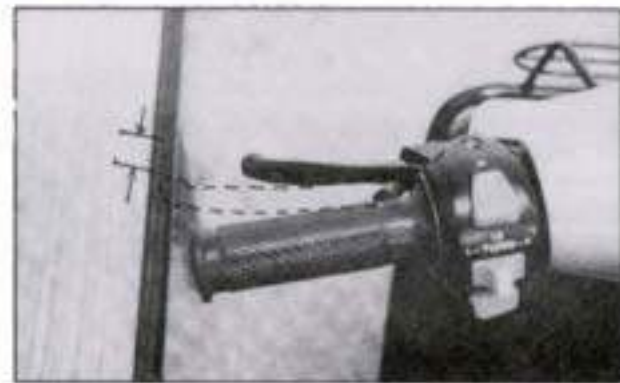
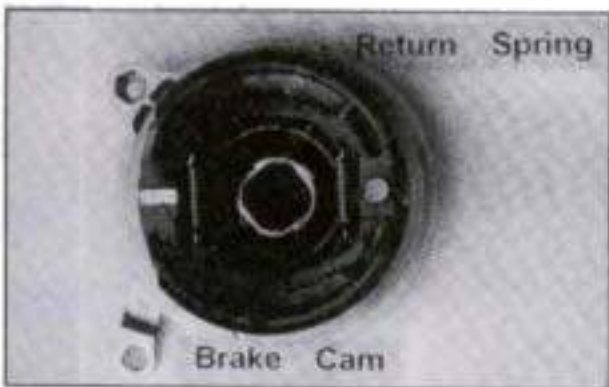
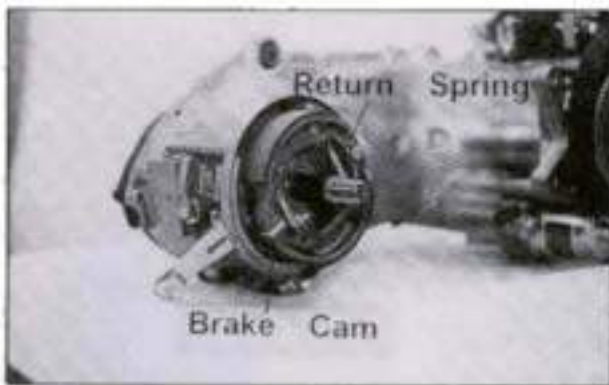

4-6 Disassembly and Inspection of Body Parts Assembly of Front Brake and Wheel

4-6-4 Assembly of Front Brake and Front Wheel:

- A. Tighten the disc brake (1).
- B. Install the gear assy of speedometer (2) on the right hand side.
- C. Install the wheel (3).
- D. Screw the front axle nut (4).
Screw Torque: 330 520 kg cm
- E. Tighten the front suspension arm (5).
Screw Torque: 180 300 kg cm
- F. Tighten the brake caliper (6).
- G. Tighten the cover of front fork (7).

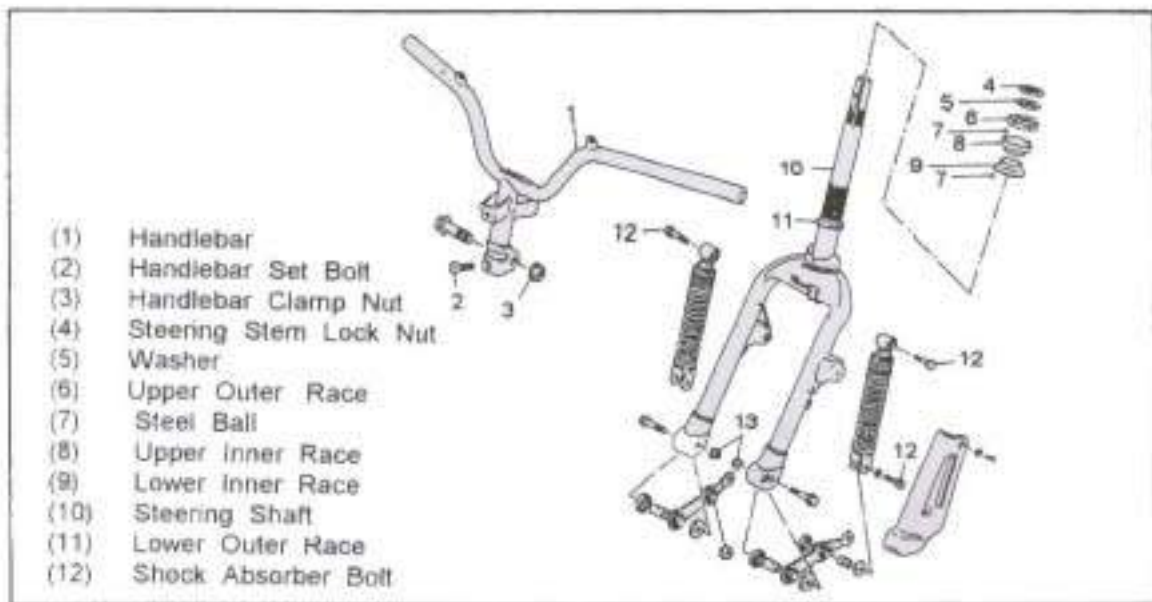

4-6 Disassembly and Inspection of Body Parts

4-6-5 Inspection of Steering Mechanism

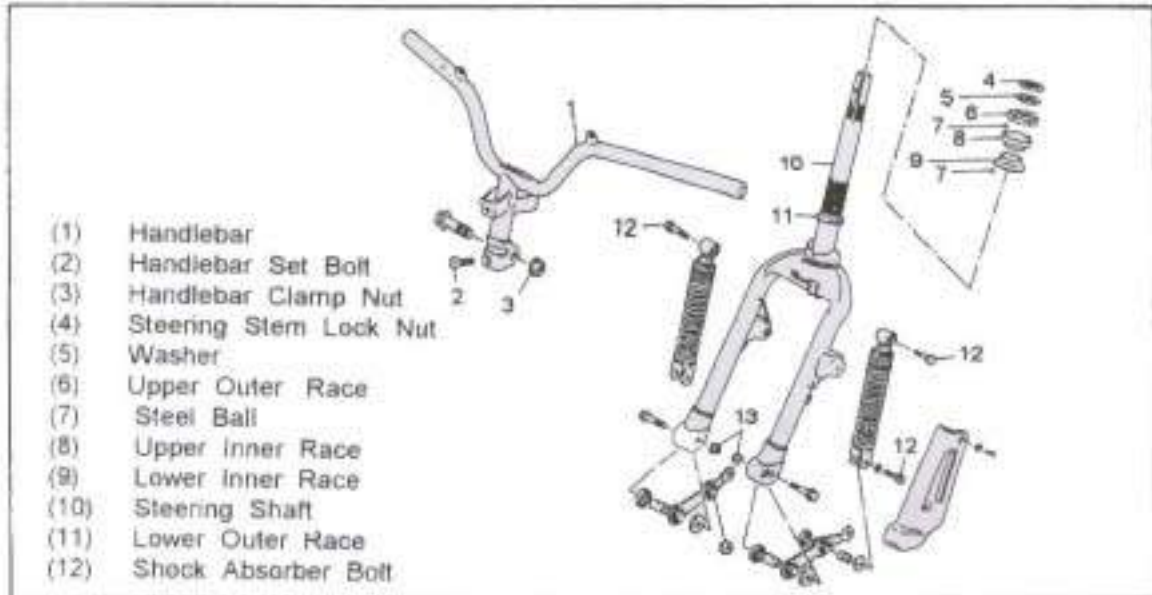

- A. Lift the front wheel to inspect.
- B. Grasp the front end of the front fork and move to and from to see if any part is loose.
- C. Turn the handle bar to left and right to see if it moves smoothly.
- D. If the handle bar is too heavy or loose, adjust the upper steering race (outer).
- E. Remove the front fender before making adjustment.
- F. Release the bearing locknut (4) of upper steering race (outer). Move the upper steering race (outer) to make adjustment.
- G. The bearing locknut should be loosened or screwed with universal vice.

Screw Torque: 600 1000 kg cm

If the upper steering race (outer) still does not move smoothly after the adjustment, it is possible that the race and steel ball are damaged or lack of grease. Disassemble to inspect.

4-7 GE5 Built-in braking system:

1. CONECTOR,FRONT BRAKE
2. MASTER CYLINDER
3. BUSH,RUBBER
4. RESERVOIR,OIL,BRAKE
5. CLIP
6. SCREW,SELFTAP
7. HOSE
8. HOSE,ASSY,FRONT BRAKE
9. CALIPER
10. CAP,GUARD
11. WASHER
12. PAD ASSY
13. DISC,BRAKE

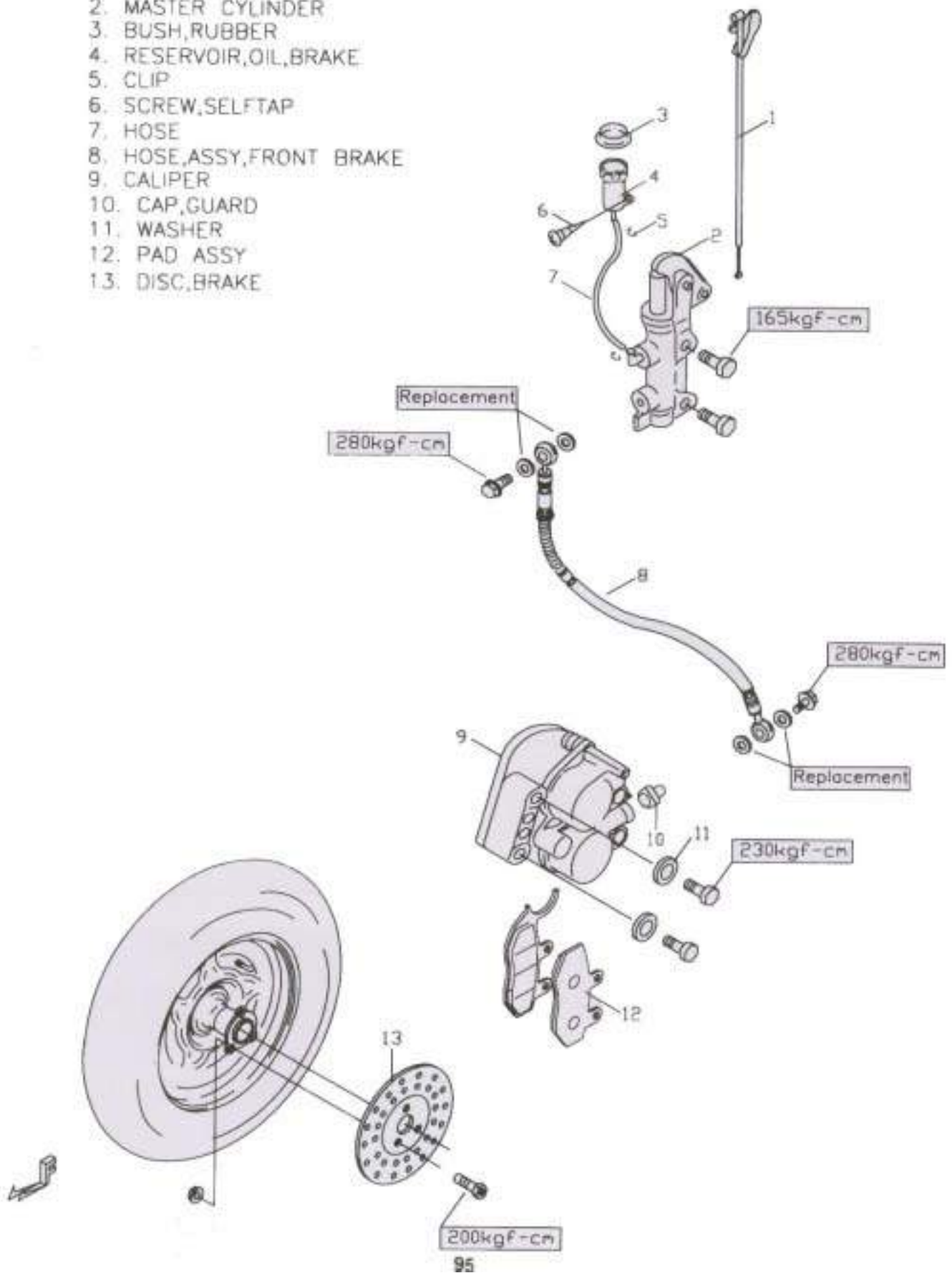

4-7 GE5 Built-in braking system:

A. Check of braking fluid level

Check: check the braking fluid level from the sight to be sure that the fluid level remains above “MIN”; if not, add in braking fluid immediately and check for leakage in the braking system.

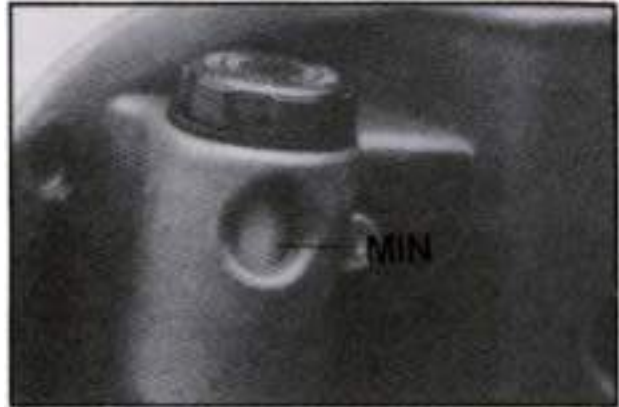

Adding of braking fluid:

- Stand the scooter at its main rest on a leveled floor.
- Turn open the fuel tank cap and add in designated braking fluid to the maximum.

Warning: 1) Add in designated braking fluid, a different fluid would cause hazardous chemical reaction, leading to failure in braking.
2) Keep water off the fluid cup or the boiling point would drop to produce air block, leading to failure in braking.
3) In case of spill of braking fluid to plastic parts, wipe it off with a rag for aestheticism.

B. Checking and adjustment of free braking gaps.

Note: front brake free gap of 10 ~ 20 mm

Adjustment of braking gap

<Remove>:

- Front windshield
- Turn lose the securing nuts, tighten the screws.

Remark : 1) Turn it clockwise to enlarge the gap.
2) Turn it counterclockwise to reduce the gap.
3) Keep the free gap at between 10 ~ 20 mm and tighten the nut.

