

Trigger

USER'S GUIDE



Dear User,

Congratulations on purchasing the Trigger Scootercar!

Please read this user manual carefully to familiarize yourself with safe and effective usage procedures.

We would like to inform you that our scootercar is produced under a strict quality control system. The Trigger must undergo all periodic maintenance and services. Besides, original spare parts must be used. In case of a structural or production defect, assistance is offered free of charge under valid warranty. The guarantee mentioned above is not valid under the following conditions:

- The designated lubricating oil is not used.
- Maintenance or repair is not carried out in the appropriate manner.
- Non-original parts are utilized and or modifications to the original design are carried out.
- The instructions in the owner's manual are not properly followed.
- Parts subject to normal wear such as the seats, spark plugs, light bulbs and cables... etc., are not covered by the guarantee.

This manual is a guide for the operation, inspection and basic maintenance of this scootercar. Please retain this manual for future reference. If you have any further questions please contact your Trigger dealer, who will be ready to help you at all times.

ATTENTION

We advise you to use a helmet and seatbelt (when installed) when riding the Trigger, even when it's not required by law.

CAUTION

Please be especially cautious when riding in the vicinity of tram rails or any metal surface because riding on top of them can make the vehicle skid. Always keep in mind that the rear wheel is located in the middle!

WARNING

Please use SAE JASO FC grade lubricant oil to refill the engine. Otherwise, the above mentioned guarantee is not valid.

Contents

1	Trigger Specifications	5
2	Identification Numbers	6
3	Trigger Part Overview	7
4	User's Guide	9
4.1	Main switch.....	9
4.2	Important Before Starting.....	10
4.3	Kick Start and Air Filter	11
4.3.1	Kick start.....	11
4.3.2	Air filter.....	11
4.4	Switches and Controls	12
4.4.1	Dashboard.....	12
4.4.2	Left Handle Bar Switch.....	13
4.4.3	Right Handle Bar Switch	13
4.5	Brake System Instructions.....	14
4.5.1	Inspection of Brake Fluid	15
4.6	Fuel Tank.....	16
4.7	Oil Tank.....	16
4.8	Tire.....	17
4.9	Charging the battery.....	17
4.10	Alarm and Radio Preparation.....	17
5	Maintenance & Inspection	18
5.1	Gear Oil Replacement.....	18
5.2	Brake Fluid Replacement	18
5.3	Inspection of Spark Plug.....	18
5.4	Light Bulb Replacement.....	19
5.4.1	Head Lights (12V 15W x 2)	19
5.4.2	Front Signal Lights (12V 10W)	20
5.4.3	Rear Lights	20
5.5	Battery and Fuse Replacement	21
5.6	Pre-operation Check.....	21
5.7	Summary of Instructions for Lubrication	22
5.8	Running in Your New Scootercar	22
6	Technical Instructions	23
6.1	Disassembling Front Body Part.....	23
6.2	Assembling Left Front Wheel.....	23
7	Reporting Safety Defects	24
8	Safe Riding Tips	25
8.1	Important Note	25



I Trigger Specifications

Table I: Specifications

Engine		GE5 50 c.c. TGB
Overall Length	mm	2350
Overall Height	mm	1240
Dry Weight	kg	170
Displacement	c.c.	49.3
Spark Plug		BPR6HS, BPR7HS, BP6HS 0,6~0,7 mm
Battery	V-AH	12V / 4AH – 7AH
Fuel		unleaded gasoline (octane 92 and up) or premium gasoline
Fuel Tank Capacity	Liter	5,3
Gear Oil		SAE 90#
Gear Oil Capacity	Liter	0.09
Brake System		front: disc, rear: drum
Light Bulbs	Head Lights	12V 15Wx2
	Rear Light	12V 5W
	Brake Light	12V 18 W
	Signal Lights	12V 10W
Tire and Wheel	Pressure	front: 2,1 kgf / cm ² , rear: 2,5 kgf / cm ²
	Dimensions	front: 120/70-12, rear: 12": 120/70 13": 120/60

2 Identification Numbers

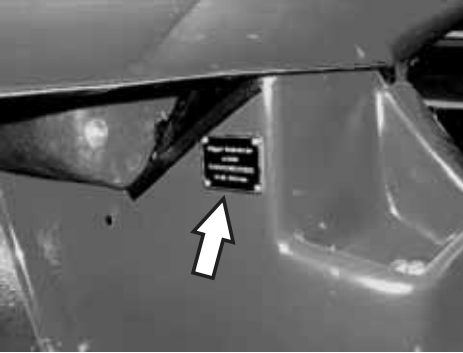

Figure 1

The frame number is located under the dashboard, as shown in the figure on the left.

This number is important when applying for an insurance policy.

The number is also engraved into the chassis, behind the right front wheel.



3 Trigger Part Overview

Figure 2

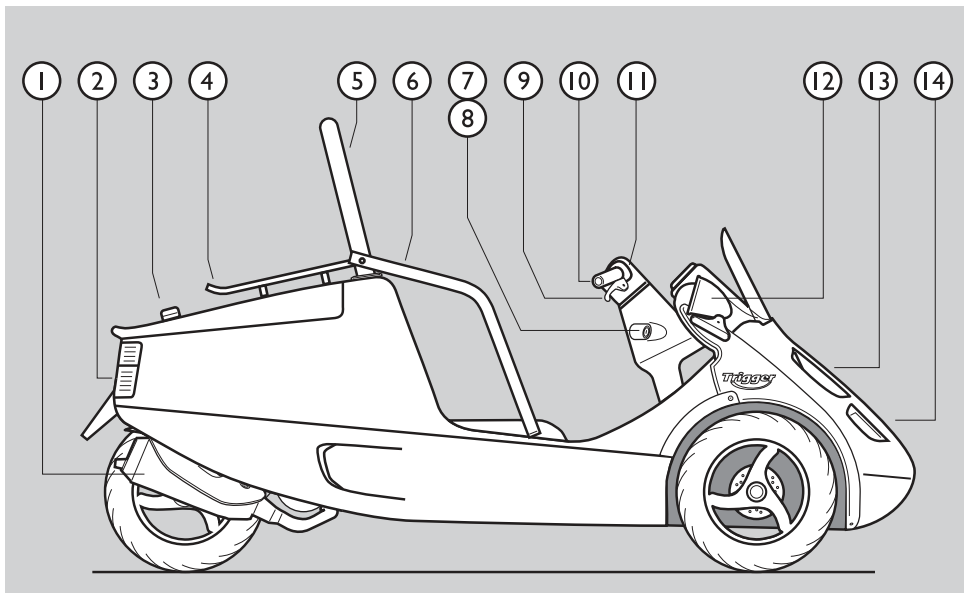
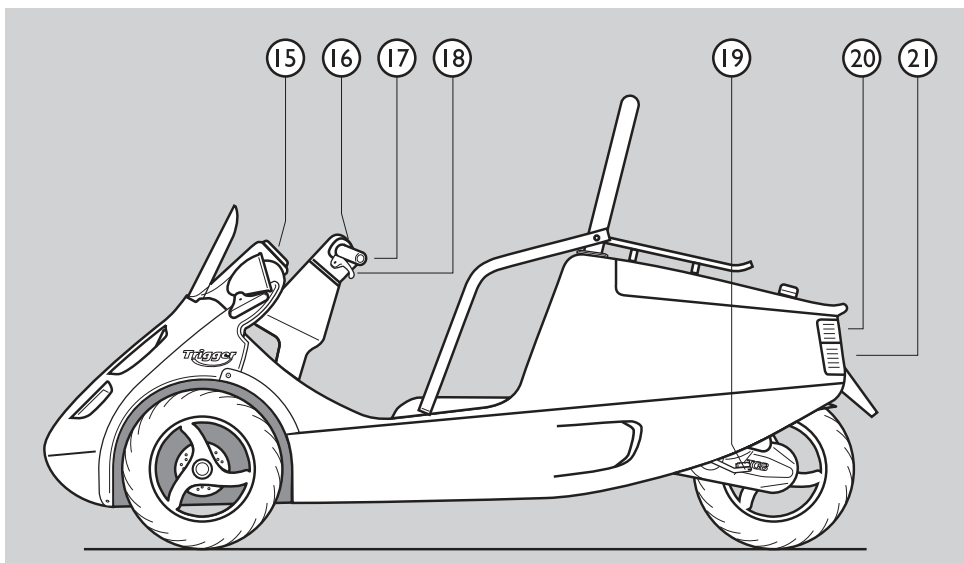

Figure 3



Trigger Part Overview *continued*

Table 2**Figure 2**

1. muffler
2. brake light
3. luggage compartment lock
4. luggage rack
5. roll bar
6. side support
7. main switch
8. steering lock
9. front brake lever
10. throttle grip
11. right handle bar switch

v

12. back mirror
13. headlight
14. front turn signal light

Figure 3

15. speedometer
16. left handle bar switch
17. left handle bar
18. rear brake lever
19. kick start
20. rear light
21. rear turn signal light



4 User's Guide

4.1 Main switch



Figure 4

The “*” position (between ON and OFF) is for checking the lubricant oil warning light. When the key is positioned at “*” the oil warning light should flash once. If it doesn't light, please contact your dealer for a replacement. Please refill the oil when it lights continuously.

Table 3: Main switch position

Position	Function	Can the key be taken out
ON	When riding and starting the engine.	no
*	Checking the lubricant oil warning light.	no
OFF	Shutting down the engine, no power to the electrical system.	yes
LOCK	Operating the steering lock: turn the handlebar to the far right side, then turn the key to the left.	yes

4.2 Important Before Starting

- Make sure the fuel tank is filled up.
- Check the oil level (as shown in paragraph 4.7).
- Make sure the key is in the “ON” position.
- Hold the brake lever and push the electric starter button or kick start. When starting after a long period of not using the vehicle, please use the kick start for 3 or 4 times or use the electric start button for 3 or 4 times. If the engine still won't start, wait a few minutes and follow the normal procedure.
- If the electric starter can't start the engine in one go, release the button for a few seconds and try again. Every attempt shouldn't last more than 5 seconds in order to avoid unnecessary battery consumption.
- The Trigger uses an automatic choke. This means that no throttle is necessary when starting the engine.
- If the Trigger keeps failing to start, take the scooter to the dealer for repair.
- To protect the engine, please avoid sudden acceleration or full speed riding.
- When you push the electric starter button and the oil warning light flashes, please take the vehicle to the dealer for detailed examination.



WARNING

Don't start the engine in a hermetically closed room. The exhaust fumes are toxic and cause people to lose conscience within a very short time. Therefore, it is necessary to start the engine in the open air.



4.3 Kick Start and Air Filter



Figure 5

air filter
kick start

4.3.1 Kick start

- When the electric starter does not work, please use the kick start instead.
- When the engine has started, relocate the kick start to the original position.

4.3.2 Air filter

The air filter must be cleaned or replaced by the dealer every 5.000 kilometers or six months.



CAUTION

When the air filter is incorrectly or incompletely assembled, dust will be sucked directly into the cylinder and causes abnormal abrasion of the engine.

4.4 Switches and Controls

4.4.1 Dashboard

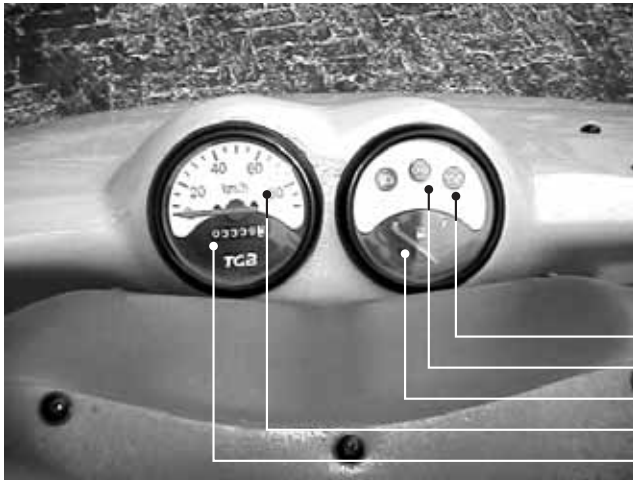

Figure 6

Figure 6

1. oil warning light (red)
Turn the main switch to the “*” position between “ON” and “OFF”. The oil warning light should flash once.
2. turn signal light (green)
When the turn signal is switched on, the light will flash and a beep will sound.
3. fuel level meter
4. speedometer
5. odometer



WARNING

Please use SAE JASO FC grade lubricant oil to refill the engine. Otherwise the guarantee is not valid.



4.4.2 Left Handle Bar Switch

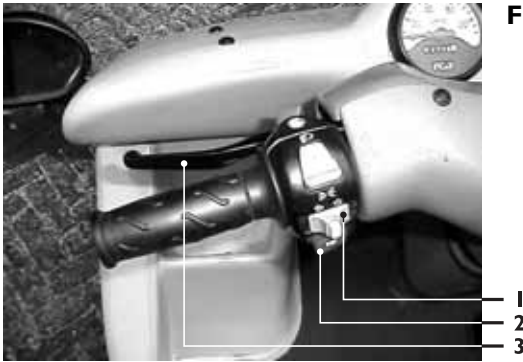

Figure 7

4.4.3 Right Handle Bar Switch



Figure 8

Figure 7

1. signal light switch \leftarrow / \rightarrow
2. horn 
- The horn will sound when pushed.
3. rear brake lever
- To start the engine, the rear brake lever must be operated.

Figure 8

1. front brake lever
2. throttle grip
- To increase throttle, turn towards you.
3. head light switch
4. electric start
- Switch the key to "ON", keep the brake lever pressed and then push the button. Do not push the electric start button when the engine is running. This can easily damage the starting mechanism.

4.5 Brake System Instructions

Figure 9

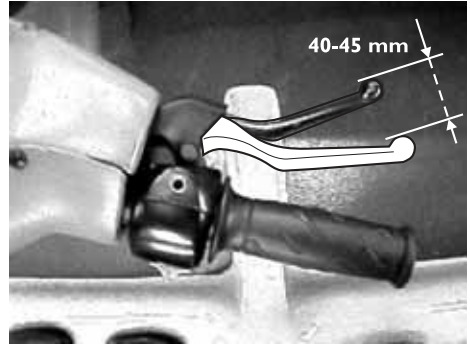
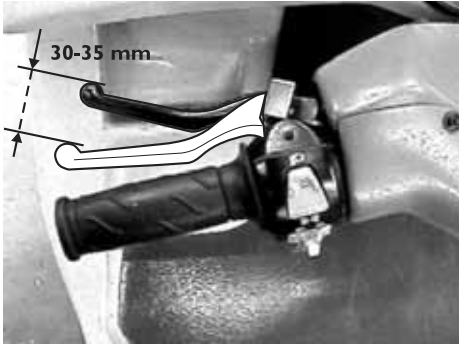

- Release the throttle before braking and apply the front and rear brakes simultaneously and gradually.
- To avoid skidding or losing control, try to avoid sudden braking.
- Braking can be extremely difficult when riding on metal surfaces, construction sites, manhole covers, tram rails and wet roads. Please slow down and pay special attention while braking under these conditions.
- When riding up- or downhill, it may be difficult to apply the brakes. Please reduce speed accordingly.



Figure 10

- Check the clearance of the front and rear lever as shown in figure 9. The left lever clearance (rear brake and parking brake) should be between 30 and 35 mm. The right hand lever (front brake) should be 40 and 45 mm. If the clearance of the right lever is incorrect, the front brake (disc) must be adjusted by an authorized dealer. The rear break (drum) can be adjusted (tightened) by turning the nut near the rear wheel clockwise. See figure 10.
-
- If pulling the break levers responds with little or no braking, it means that something is wrong with the system. Please take the vehicle to the dealer for detailed inspection immediately.





Figure 11

- To use the parking brake, push the small lever **2** down while pulling the left brake lever **1**.

4.5.1 Inspection of Brake Fluid

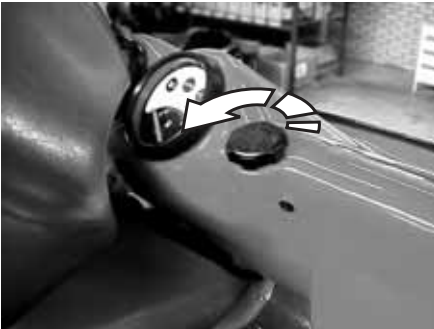
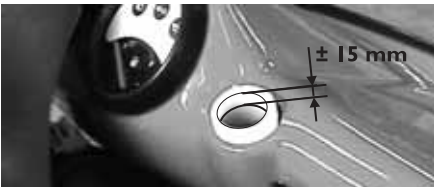

Figure 12

- Please check the brake fluid level regularly. It should be approximately 15 mm from the top (as shown in figure 12 on the left). Please refill immediately when the oil is below this level.
- Always use DOT #4 brake fluid.
- The brake may not function when the fluid level is below the normal level.
- If undesignated brake fluid is used, the brake may fail due to different chemical reactions resulting from other brand products.
- To avoid corrosion of the plastics parts, please clean spilled brake fluid with a dry cloth.



- When refilling the brake fluid, be careful not to allow water to get mixed with the fluid. Otherwise air bubbles may be formed which cause the brakes to malfunction.



ATTENTION

Please make sure the brake fluid is replaced by your dealer every two years.

4.6 Fuel Tank



Figure 13

- When the fuel indicator is on “E” position, you may have to refill the tank immediately.
- The fuel inlet is located next to the passenger seat.
- Always use premium or unleaded gasoline (euro 95).
- Don’t overflow the fuel tank.

⚠ WARNING
 Since gasoline is inflammable, please do not smoke or get in the vicinity of fire. Turn off the engine even when you pump gasoline in an airy space. If you inhale too much gas or swallow gasoline, seek medical attention immediately.

4.7 Oil Tank



Figure 14

- If the oil warning light (figure 6,1) in the dashboard is on when riding, it is a warning sign that the oil is about to run out. Refill the tank with JASO FC CLASS 2-stroke classified oil as soon as possible.
 - Don’t let the oil tank become empty or the engine will easily be damaged.
- Always use designated two stroke oil or the same classification as JASO FC CLASS 2-stroke oil

⚠ WARNING
 Application of the wrong oil can result in the engine operating at low efficiency, reduced horsepower or damage to the engine.



4.8 Tire

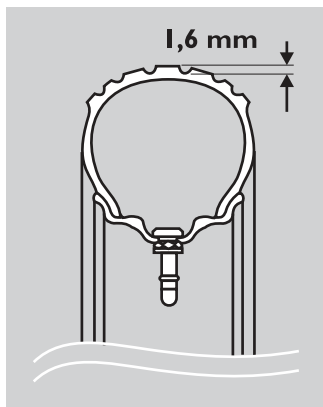

Figure 15: Partial cross-section of tire and rim

- Tire pressure affects riding performance, appropriate pressure will make riding smoother.
- When the groove depth is less than 1.6 mm, please change the tire as soon as possible, or riding will be slippery on wet or bumpy roads.
- Front tire pressure: 2,10 kg/cm²
- Rear tire pressure: 2,50 kg/cm²
- Since the scootercar is fitted with tubeless tires, please repair the tire surface directly when pierced by sharp thorns, nails etc.

4.9 Charging the battery

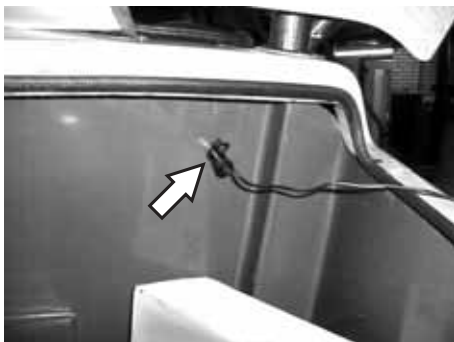

Figure 16

- The battery can be charged by means of a connector in the storage space of the Trigger.
- Use the charger (optional) that came with the scootercar or a model with equal power output (12V - 400 mAH).

4.10 Alarm and Radio Preparation

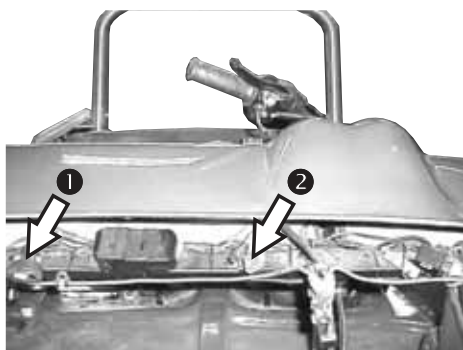

Figure 17

- Please note that the electrical system of the Trigger is prepared for alarm ① and radio ②. The connectors are located in the dashboard, as shown in figure 17.
- When the Trigger is fitted with a radio, we advise to use a battery with more capacity, 12V / 7AH instead of 4 AH.

5 Maintenance & Inspection

5.1 Gear Oil Replacement

- Change of gear oil should be carried out after the first 1000 km. After that, oil should be changed every 5.000km.
- Gear lubricant code SAE 85W-90.
- The gear lubricant inlet is located at the left hand side of the rear wheel on top of the crankcase.
- Change of the gear oil should be carried out by the dealer.

5.2 Brake Fluid Replacement

- Replacement of brake fluid should be carried out every two years.
- Always use DOT #4 brake fluid.
- The brake fluid inlet is located under the right handlebar (paragraph 4.5.1).
- Change of the brake fluid should be carried out by the dealer.

5.3 Inspection of Spark Plug

Figure 18

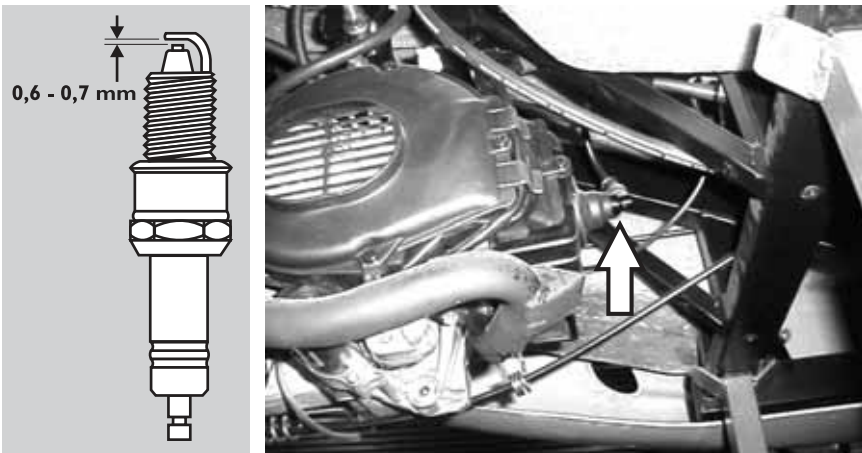

- Disconnect the H.T. cable from the spark plug cap and turn counterclockwise.
- When reassembling, make sure that the thread of the spark plug aligns with the one in the engine.
- Standard spark plug: NGK BPR6HS or BPR7HS.
- The spark plug must be periodically cleaned in order to keep a proper ignition.



- Before installing the spark plug, check the electrode gap with a gauge and modify if necessary to measure 0.6-0.7 mm (figure 16).
- When reinstalling the spark plug, clean the gasket surface and utilize a new gasket. Tighten the plug with a torque of 20N/M (2.0 kg/M).

5.4 Light Bulb Replacement

5.4.1 Head Lights (12V 15W x 2)

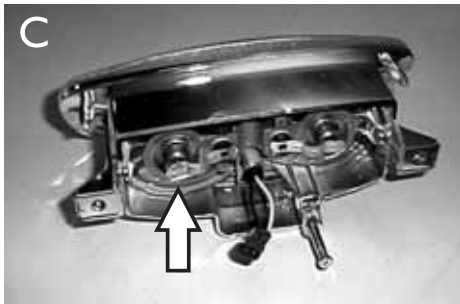
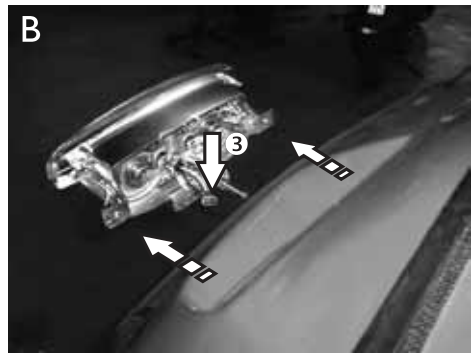
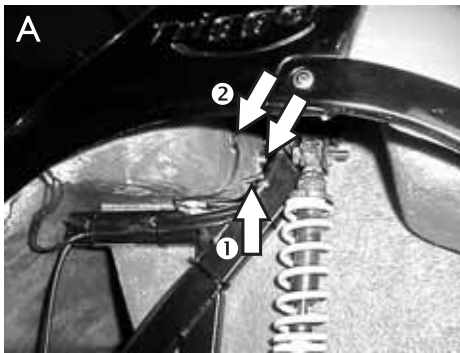

Figure 19

Disassembling the headlight.

- Unfasten both screws that hold the headlight ② (18A) from the inside of the body.
 - Disconnect the power plug ③ (18B).
 - Take the entire headlight out (18B).
 - To remove the bulb, turn the contact spring away from the rear of the bulb (18C).
- Only replace the outer bulb with a 12 Volt 15 Watt one (the inner bulbs are not used).
 - When reassembling the headlight, adjust the light beam by turning screw ① if necessary.

5.4.2 Front Signal Lights (12V 10W)



Figure 20

Disassembling the light bulb socket.

- Turn the bayonet catch counter clockwise from the inside of the body.
- Replace with a 12 Volt 10 Watt bulb.

5.4.3 Rear Lights

Figure 21

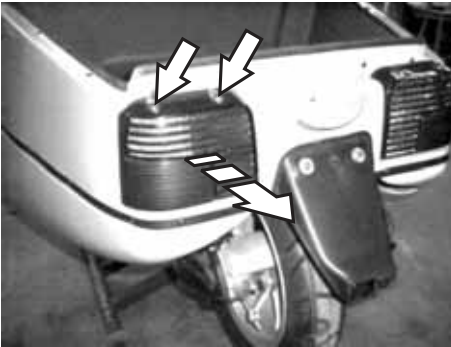

Disassembling the rear light reflector.

- Unfasten both screws at the top to take off the outer reflector.
- To remove a bulb turn it counter clockwise.
- ❶ rear light: 12 Volt 5 Watt bulb
- ❷ signal light: 12 Volt 10 Watt bulb
- ❸ brake light: 12 Volt 18 Watt bulb



5.5 Battery and Fuse Replacement

Figure 22

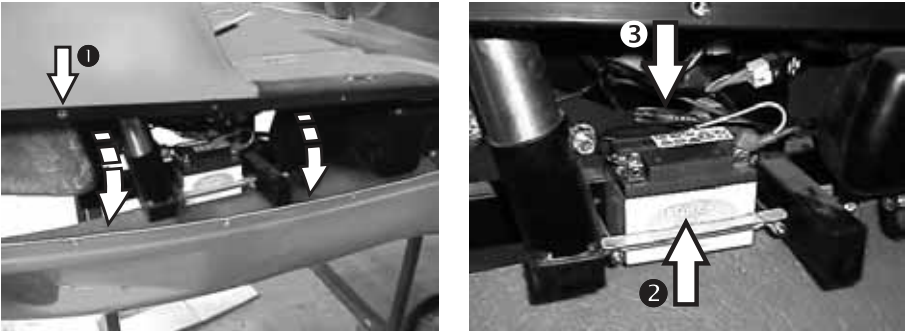

- Disassemble the right skirt by unfastening the parkers ❶.
- This part is hinged to the underside of the chassis.
- The battery ❷ is clamped to the chassis and can be replaced by unfastening both nuts.
- The 10A fuse ❸ is located in a separate container that can be unscrewed for replacement.

5.6 Pre-operation Check

Table 4: Before operating the scootercar, the following points must be checked:

inspection items	description
front brake	Check whether brakes function within normal parameters.
rear brake	
tires	Check whether tire pressure is sufficient. Check whether tires are damaged or cracked.
light	Check whether brake light functions normally. Check whether signal lights function normally. Check whether all the lights are clean.
back mirror	Check whether reflecting images are clear. Check whether glass is clean.

5.7 Summary of Instructions for Lubrication

Table 5: periodical lubrication instructions

item	1st time	2nd time etc.	lubricant
rear brake nut (Figure 10)		3.000 KM	Grease
speedometer gear box	3.000 KM	4.000 KM	Grease
bearing. (front and rear wheel)	6.000 KM	3.000 KM	Grease
bearing. (handle bar)		6.000 KM	Grease
brake and throttle cable		3.000 KM	Grease
gear box reduction	300 KM	5.000 KM	Oil

5.8 Running in Your New Scootercar

- Take good care of your new vehicle within the first 1.000 KM and operate it smoothly in order to maintain every part in proper condition. Try not to accelerate with full throttle.
- When a cylinder, piston, or crankshaft is replaced, please avoid full speed riding within the first 1.000 KM.
- Avoid full acceleration when the scootercar is not in optimal condition.



6 Technical Instructions

⚠ **DISCLAIMER**

The information on this page is for technical reference purposes only. The instructions / maintenance should only be carried out by your Trigger dealer. Trigger Technics is not responsible for any damage resulting from improper use.

6.1 Disassembling Front Body Part

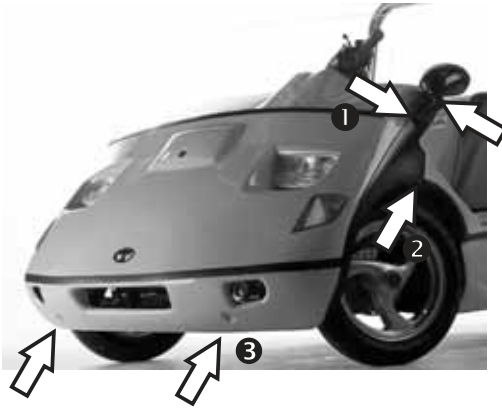

Figure 23

To disassemble the front body part (to reach the radio / alarm preparation):

- Remove the mirror from its socket. Then remove the socket itself. ①
- Remove parker to separate from mid-section. ②
- Unfasten two parkers at the bottom. ③

6.2 Assembling Left Front Wheel

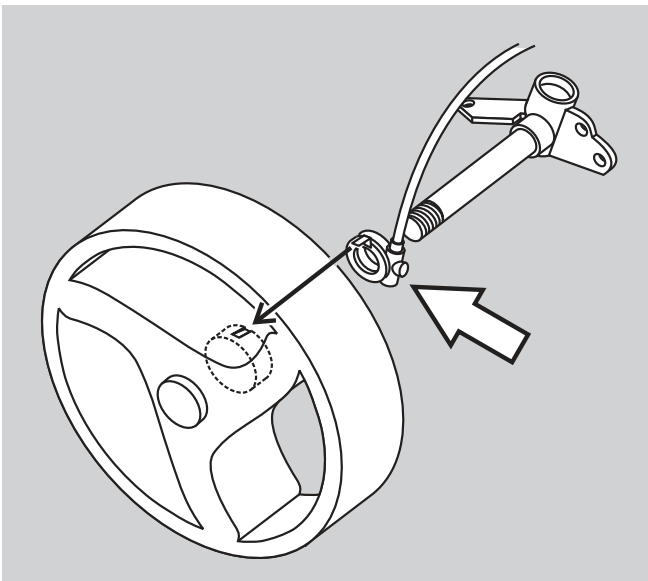

Figure 24

To assemble the left front wheel, make sure the speedometer sensor (⇔) fits together with the wheel rim as shown in figure 23 on the left.

7 Reporting Safety Defects

For United States customers only.

Trigger Technics BV
Oosterkerkstraat 18
2312 SN Leiden
The Netherlands

Reporting Safety Defects

If you believe that your vehicle has a defect which could cause a crash or could cause injury or death, you should immediately inform the National Highway Traffic Safety Administration (NHTSA) in addition to notifying *Trigger Technics BV*.

If NHTSA receives similar complaints, it may open an investigation, and if it finds that a safety defect exists in a group of vehicles, it may order a recall and remedy campaign. However, NHTSA cannot become involved in any individual problems between you, your dealer, or *Trigger Technics BV*.

To contact NHTSA you may either call the Auto Safety Hotline toll-free at 1-800-424-9393 (366-0123 in Washington, DC area) or write to:

NHTSA
U.S. DEPARTMENT of TRANSPORTATION
400 7th Street SW, (NSA-11)
Washington, DC 20590

You can also obtain other information about motor vehicle safety from the Hotline.



8 Safe Riding Tips

- When riding the Trigger, we advise you to use a helmet and seatbelt (when installed), even when it's not required by law.
- Always keep in mind that the Trigger is a three wheeled vehicle. If one of the front wheels lifts when making a sharp turn, the rear brake can be used to stabilize the vehicle.
- Braking may be difficult on wet roads, so please avoid sudden braking, or the scootercar may skid.
- Always slow down when approaching a turn.
- When passing by a car, be aware of doors opening unexpectedly. Always keep alert.
- Always ride carefully when passing tram rails or construction sites covered with metal surfaces.
- Immediately after washing, the brake lining may still be wet. Therefore inspect the brake effectiveness before riding.
- Always be aware of local safety regulations.



ATTENTION

After having operated the vehicle for a while, the exhaust becomes very hot. Please park the scootercar properly and maintain a safe distance from pedestrians and children to avoid contact with the muffler.

8.1 Important Note

Herewith we advise the user that whatever modification to the engine or to the parts with the purpose of increasing either the speed or the horsepower, is strictly prohibited by law.

Please always consult the professionals at the dealer's station about any modification to the engine or parts.

Before utilizing the scootercar, make sure you have a valid driver's license and the scootercar has been homologated by the local transportation authority.

Before going on the road inspect all critical parts (paragraph 5.6).

Furthermore, we would like to inform the user that any modification to the scootercar without authorization may affect the validity of your insurance policies or your license may be suspended. If the user has any questions with regard to a part or the scootercar as a whole, please consult our distributor or agent for more details.

We wish you many happy kilometers with the Trigger!