



TORROT

User manual KIDS

- Trial ONE (TT-T1022-E)
- Motocross ONE (TT-E1022-E)
- Supermotard ONE (TT-S1022-E)
- Trial TWO (TT-T1222-E)
- Motocross TWO (TT-E1222-E)
- Supermotard TWO (TT-S1222-E)





2021 TORROT ELECTRIC EUROPA, S.A.

C/ Unicef 17, Polígono Industrial Torremirón 17190 – Salt (Girona) – Spain

All rights reserved.

Total or partial reprinting and reproduction of any kind without written permission from the intellectual property owner is prohibited. TORROT ELECTRIC EUROPA, S.A. reserves the right, without prior notice and without being required to state the grounds, to change the technical content or performance of the products.

The models in the images may be shown with special equipment that the standard model does not have, or which belongs to a similar model.

The models in the images may not correspond to the original product.

PRESENTATION

Legal information

Before using the vehicle, read this user manual carefully and keep it for future reference. If you have any query or question, please contact your nearest official TORROT dealer at: www.torrot.com. You can also write to us at info@torrot.com, stating the serial number, your query and your contact details.

This manual contains important information about safety, operation and maintenance of the vehicle. The information and instructions are aimed at end users. This manual is not designed for professional use; if you are a professional, consult this vehicle's Workshop Manual.

Thank you to the consumer

By choosing one of the new TORROT KIDS, you have just joined the TORROT family and, as a user of a historic brand, you deserve the distinguished treatment we will offer you, both in the explanations we give you in this manual and in our post-sale relationship.

Our TORROT KIDS are fun electric motorcycles designed for young riders.

In this manual you will find the information you need for the correct use and maintenance of your KIDS motorcycles. It also contains information about the two-year warranty of your new electric motorcycle.

Congratulations, without a doubt you have made the right choice. With your skill at the motorcycle's handlebar, appropriate training and essential checks to ensure it is highly reliable, you can enjoy the most comfortable and gratifying initiation into the world of electric motorcycles.

Thanks for giving us your trust in us and welcome to TORROT.

1. IDENTIFICATION OF THE MOTORCYCLE	1
1.1. Identification plate	1
1.2. Bluetooth device	1
2. SAFETY INSTRUCTIONS.....	2
2.1. Safety notices and warnings	2
2.2. Use according to instructions.....	2
2.3. Before using the vehicle	2
2.4. Pictograms	3
2.5. Safety advice and warnings when using the motorcycle	4
2.6. Fire risk.....	5
2.7. Tampering warning.....	5
2.8. Work on the vehicle	5
2.9. Cleaning of the vehicle	6
3. SUPPLY, TRANSPORT AND STORAGE OF THE VEHICLE	7
3.1. Supply of the vehicle	7
3.2. Transportation of the vehicle.....	8
3.3. Storage of the vehicle	8
4. INTRODUCTION.....	10
4.1. Quality	10
4.2. Environment.....	10
4.3. Trial series ONE and TWO.....	10
4.4. Motocross series ONE and TWO.....	10
4.5. Supermotard series ONE and TWO	11
5. WARRANTY CONDITIONS	12
5.1. Two (2) years [three (3) years for Spain & Portugal] warranty for	12
5.2. Limited repair.....	12
5.3. Exclusions	12
5.4. Appendices.....	13
5.4.1. Online warranty registration	13
5.4.2. Transfer of the warranty (only MUVI)	13
5.4.3. The user's liability	13

6. LOCATION OF COMPONENTS	15
6.1. Trial.....	16
6.2. Motocross.....	17
6.3. Supermotard.....	18
6.4. Other components	19
7. TECHNICAL SPECIFICATIONS	20
7.1. ONE Trial	20
7.2. TWO Trial.....	21
7.3. ONE Motocross	22
7.4. TWO Motocross.....	23
7.5. ONE Supermotard	24
7.6. TWO Supermotard.....	25
8. USE AND MAINTENANCE	26
8.1. Chassis	26
8.2. Swingarm	26
8.2.1. Maintenance of the swingarm.....	27
8.3. Lithium-ion batteries or accumulators	27
8.3.1. Charging the battery.....	28
8.4. Motor.....	31
8.4.1. Maintenance of the motor.....	31
8.5. Brakes	31
8.5.1. Brake maintenance	32
8.6. Forks and steering	32
8.6.1. Maintenance of forks and steering	33
8.7. Rear shock absorber.....	33
8.7.1. Maintenance of the rear shock absorber	34
8.8. Transmission	34
8.8.1. Maintenance of the transmission	36
8.9. Rims and tires	36
8.9.1. Maintenance of the rims and tires	37
8.10. Side stand.....	37
8.11. Speed and power limiting device	38
8.11.1. Speed limiting adjustment protocol	38
8.12. Man overboard device.....	38

INDEX

8.13. Throttle and battery charge level indicator	39
9. MAINTENANCE SCHEDULE	40
10. TIGHTENING TORQUES	41
11. STARTING AND STOPPING THE VEHICLE	42
11.1. Inspection and care before each ride	42
11.2. Starting the vehicle	42
11.3. Stopping the vehicle	43
12. CONNECTION TO THE VEHICLE USING THE BLUETOOTH APP	44
12.1. How to begin	44
12.2. Configuration menu	46
12.3. Parental control menu	47
13. FAULT DIAGNOSIS.....	49
14. FINAL REFLECTIONS	50
14.1. FAQs	50
14.1.1. Does the motorcycle have a speed limiting device for new riders?	50
14.1.2. Is there a minimum age for using the KIDS?	50
14.1.3. Can you ride it on the road?	50
14.1.4. Do I need any kind of third-party civil liability insurance?.....	50
14.1.5. Is it waterproof?	50
14.1.6. Can the charger be left continuously connected to the battery?.....	51
14.1.7. Why is the autonomy reduced when it is very cold?	51
14.1.8. Does it have regenerative braking?	51

1. IDENTIFICATION OF THE MOTORCYCLE

1.1. Identification plate

The TORROT KIDS bears the serial number engraved on a label on the steering pipe, which identifies the motorcycle and must match the vehicle's documentation.



Next, record the serial number in the spaces provided for that purpose in the manual to make it easier to process your requests for replacement parts, or for reference if the motorcycle is lost.

- **VEHICLE'S SERIAL NUMBER:**



1.2. Bluetooth device

The TORROT KIDS has Bluetooth connectivity via a smartphone application. The section *Connect using the Bluetooth APP* explains the operation of this device and of the application.

To pair your smartphone with the vehicle, you need to know the Device ID of your Bluetooth device, as well as your PIN.

You can find this information on the key card next to the motorcycle keys.

This information can also be found on a sticker at the top of the Bluetooth device.

Next, note the Bluetooth module's identification code and pin in the spaces provided for that purpose in the manual, to keep this information should you lose the label.

- **DEVICE ID:**

- **PIN:**

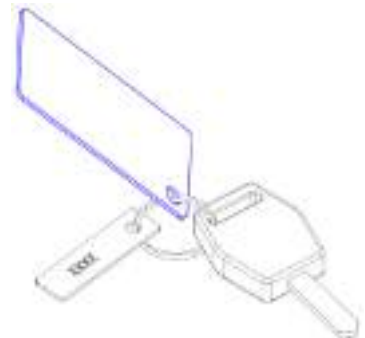



2. SAFETY INSTRUCTIONS

This section only gives general safety instructions about the vehicle. Read all the instructions in this manual to understand all the risks or dangers that may arise during or as a result of the use and maintenance of the vehicle.

Keep this manual in an accessible place for future queries. This manual is also part of the vehicle, so it should be provided along with the vehicle if it is being sold. You can also download this manual for free on our website: www.torrot.com.

2.1. Safety notices and warnings

All instructions, notices and warnings in this manual must be heeded.

The meaning of the notices and warnings are explained below:



This symbol explains all the rules and precautionary measures whose purpose is to prevent minor and serious physical harm and even the death of the user if the instructions are not followed properly.



This symbol gives the special warnings to prevent damage to the motorcycle. If they are not followed, the vehicle's warranty may be automatically terminated.

2.2. Use according to instructions

This vehicle was designed and built to withstand the conditions that are normally found in using it off-road, as long as the weight of the rider does not exceed 30 kg.

The vehicle is designed exclusively to transport one person.



Use the vehicle properly only on designated off-road areas, for the specific tasks for which it was designed. In the event of inappropriate use, personal, property and environmental damage may be caused.

In some countries specific regulations may be applied regarding age, speed limit, intended use or the areas provided for this type of vehicle. Please ensure you are properly informed and comply with the regulations in force where you intend to use this vehicle.

2.3. Before using the vehicle

Read this manual carefully to obtain important information about the safety, use and maintenance of the vehicle.



Never start the vehicle if it shows visible signs of fault or damage.

Before each use, carry out the inspection procedure described in the section *Inspection and care before each ride*.

2.4. Pictograms

The vehicle contains notice and warning pictograms. These pictograms should never be removed from the vehicle. If they fall off, are erased or are not perfectly visible, they must be replaced. Please contact your nearest official TORROT dealer to get the spare part (ref. BE95245TT-CNC-1).



All the pictograms must be heeded.



The meanings of these pictograms are explained below:



Read the user manual carefully



The vehicle takes only one occupant



The vehicle is not designed for road use



Always use a helmet and protective equipment



It is not suitable for children aged under 6 years



Children must only use the vehicle under adult supervision



Rider maximum weight 30 kg



2.5. Safety advice and warnings when using the motorcycle

This motorcycle must be used by children always under supervision of an adult, responsible of their safety and who has trained them in the properly use of the vehicle and is aware of the harm that may be suffered.

All children must be assessed as regards their skill in riding safely. All children who are allowed to ride must be appropriately supervised.

To prevent injuries, the riders must always wear appropriate protection for using the vehicle, such as: a helmet, boots and gloves, as well as trousers and a jacket with protections.

Before allowing a rider to ride the vehicle, the parents or legal guardians must assess whether they are ready to ride it. The training required to ride differ from person to person and, age and size are not the only factors to take into account (for example, physical skill, mental and emotional maturity, etc.).



Before allowing any rider to ride, the person responsible for supervising them must verify that the rider is capable of actuating and reaching any control and device necessary to ride the vehicle.

Before allowing any rider to ride this vehicle, ensure they understand the instructions and notices contained in this manual.

To prevent unauthorized use of the motorcycle, keep the key out of children's reach after each use of the motorcycle, or when you are not supervising them.

The motorcycle has a speed and power limiting device activated as standard. Ensure that your child is properly trained before deactivating this system.

For a rider to be able to use the motorcycle, they must be able to lift the motorcycle off the ground by themselves after falling off.

If it is their first motorcycle, we recommend they take a training course before using the vehicle.

Some components of the vehicle may get very hot during use. Do not touch any component until it has cooled off.



The components that can become hot while using the motorcycle are the following:

- Engine (not visible in the image)
- Front and rear brakes
- Forks
- Rear shock absorber
- Battery
- Charger (not visible in the picture / The charger may get hot while charging the battery)

2.6. Fire risk



As in any electric vehicle, the lithium-ion accumulators (batteries) entail a fire hazard.

If your vehicle catches fire or is involved in a fire, you must report to the fire brigade that there has been a fire in a lithium-ion accumulator vehicle.

If the lithium-ion accumulators (batteries) are in perfect condition, there is no special risk of fire with this vehicle. If the batteries show signs of deterioration, please contact your nearest official TORROT dealer.

2.7. Tampering warning



Any change, modification or tampering with the mechanical, electrical or electronic features of the vehicle are not allowed. If you do that, it cannot be guaranteed that it will operate safely, and the vehicle's warranty will be lost.

2.8. Work on the vehicle

Follow the instructions in this manual to do a properly maintenance to the vehicle.

Special knowledge and a capacity for technical understanding may be required to carry out certain maintenance or repair tasks. For the safety of the rider and the person responsible for the repair, please go to your nearest official TORROT dealer.

If, for a given repair, there are no instructions in this manual, or they are not clear enough, please contact your nearest official TORROT dealer.



For the driver's safety, only use approved TORROT spare parts and/or accessories. TORROT shall not be held liable for the damages arising from the use of other products.

You should not attempt to open any electric or electronic component of the motorcycle (battery, motor, controller, throttle, Bluetooth module, man overboard device or battery connector) under no circumstances.



Use the oils, lubricants and other service agents indicated in this manual.



Use the tightening torques indicated in this manual.

Before beginning work on the vehicle, ensure it is switched off. The vehicle is very silent, and if the throttle were actuated with the vehicle switched on, it would move uncontrollably.

There is a risk of electrical shock when working with electrically live components. Specific training, qualifications and tools are required to work with electrical systems.



Remove the battery and wait for 5 minutes before carrying out any maintenance or repair on the vehicle. Even without a battery, until 5 minutes have passed from the removal of the battery, there is a risk of shock if the vehicle is handled.

Some parts may get very hot while using the motorcycle. Do not carry out the maintenance work until they have cooled off.

2.9. Cleaning of the vehicle

Using soaps or chemical products to clean the vehicle may damage the surface of the plastics or the paint on the parts.



Do not clean the motorcycle with the battery in. Remove it as shown in the section *Charge the battery outside the vehicle* and wait at least 5 minutes before beginning to clean the vehicle.

Do not use water or any other conducting product to clean the battery.

Carefully remove the mud, earth, dust and other external elements that may get into the battery compartment during its use.



Never clean the braking systems with soap or generic chemical products. Only use products specifically for brakes.



After the cleaning, make sure to dry the brakes by braking carefully and in a controlled way.



Do not clean the motorcycle with pressurized water. A gentle jet of water would be enough to remove the dirt.

The motorcycle is under no circumstances prepared against submersion.

3. SUPPLY, TRANSPORT AND STORAGE OF THE VEHICLE

3.1. Supply of the vehicle

Check that the packaging and/or the vehicle has no damage.



Danger of asphyxia with the packaging material. Keep out of children's reach.

If you receive the motorcycle in a box, the package contain the following:

- 1x KIDS Motorcycle with battery
- 4x M6 Allen Screws (fitted on the bar mounts)
- 1x Battery charger
- 1x Battery spacer foam
- 1x "Welcome to TORROT KIDS" information leaflet

If you receive the vehicle in a box, you must fit the handlebar. Follow the steps described below:

1. Unscrew the 4 Allen screws (1) on the bar mounts.
2. Replace the plastic tube with the handlebar and gently tighten the 4 Allen screws.
3. Unscrew the ULS M6 screw (2) from the plastic number plate to properly guide the brake hoses and the cables. (*)
4. Adjust the handlebar to the angle at which the rider is comfortable and then firmly tighten the 4 Allen screws.
5. Fit the plastic number plate again. (*)

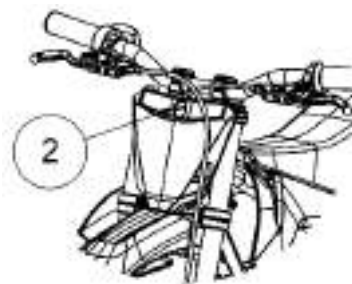
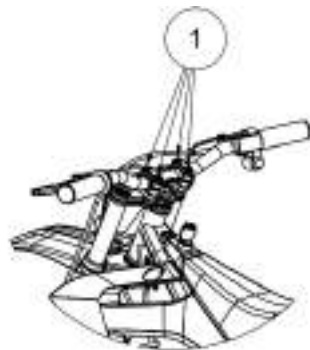

(*) Only Motocross and Supermotard models.



The handlebar fitting operation is a delicate operation that may entail safety problems with the vehicle's structure and steering. To do this, please contact your nearest official TORROT dealer.



Remember to fill out the serial number, key number and Bluetooth device information inside the boxes into the Identification of the motorcycle section.

The motorcycle's packaging includes a foam spacer for the battery. It is between the bottom of the battery and the battery compartment.

As standard, the vehicle is supplied with the battery disconnected and its state of charge below 30% of its maximum capacity. To connect it for the first time, and after each ride, the battery must be removed as explained in the Charge the battery outside the vehicle section and the foam spacer that is between the battery connector and the battery compartment should be removed.



3.2. Transportation of the vehicle

To transport the battery inside the motorcycle, the foam spacer must be between the battery connector and the battery compartment.

It is important to inspect that foam before each transport and, if it shows signs of wear and tear, it must be replaced. Please contact your nearest official TORROT dealer to get the spare part (ref. ACTT-11004).

To transport the battery, it must be charged to less than 30% of its full capacity. To check this value, connect the battery to the motorcycle and, upon switching it on, check that the battery charge level indicator shows 1 charge line.

The battery must be transported according to the rules and regulations in force in each country.

To transport the vehicle outside its box, the motorcycle must be secured with fastening straps or other suitable devices to prevent it from falling off during transit. Fix the fastening straps as it is shown in the following image:

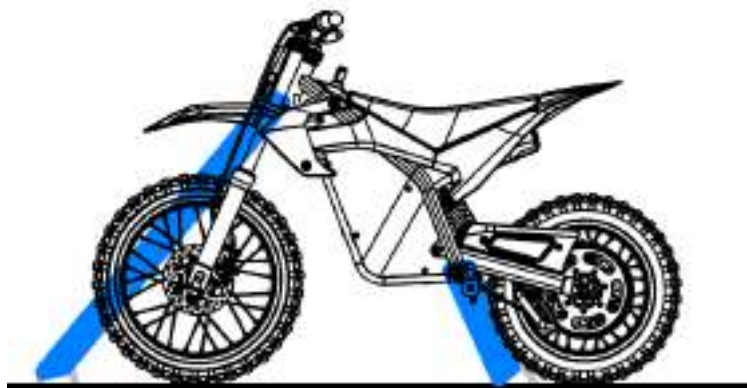

3.3. Storage of the vehicle

When you are going to store the motorcycle for a long time, you must:

- Remove the battery from the motorcycle as explained in the Charge the battery outside the vehicle section or insert the battery separator foam as explained in the Supply of the vehicle section.
- Thoroughly clean the motorcycle and wait for it to dry fully before storing it (follow the instructions in the Cleaning of the vehicle section).
- Lubricate the chain and all the moving parts.

- Put oil on the unpainted metal surfaces to prevent rust, prevent it from falling on the brakes and on rubber parts.
- Raise the motorcycle such that the two wheels do not touch the ground (if this is not possible, put cardboard under the wheels).
- Cover the motorcycle to protect it from dust and dirt.
- Inspect periodically the vehicle to ensure all its components are working properly and then re-cover it.



Inspect periodically the battery charge level. The charge level must be 40-60%. To check this charge value, connect the battery to the motorcycle and, upon switching it on, check that the battery charge level indicator shows 2 or 3 charge lines. If it is under that level, connect the charger until it reaches the stated level. If it is above that level, use the motorcycle until it reaches the stated level.

- If the battery will be stored for a long time, one to three complete discharge-charge cycles should be carried out every 3 months to preserve the battery's performance. After such cycle(s), if you want to store it, it must be kept in the storage conditions.

The conditions of the place where the vehicle is stored must be as follows:

- A dry, clean, well-ventilated place free of corrosive gas.
- The temperature must remain between 15 and 25°C.
- The humidity must be between 45 and 75%.
- It must not be exposed to direct sunlight.

To operate the vehicle after storage:

- Perform a general lubrication.
- Inspect the tire pressure and, if necessary, inflate them to the pressure indicated in this manual.
- Charge the battery to 100% and then connect it to the motorcycle.



4. INTRODUCTION

The KIDS series electric motorcycles for young riders allows for quick learning and progression in the two wheels world. There is nothing like these miniaturized Trial, Motocross and Supermotard motorcycles!

KIDS have been designed so that the child's first contact with the motorcycle is as real and authentic as possible in terms of architecture, ergonomics, and performance. Moreover, very high passive safety standards have been followed designing it, to make the experience 100% positive and safe.

Besides learning and having fun, KIDS motorcycles offer children solid pedagogic values, as well as improves their psychomotricity: responsibility, balance, concentration, etc. Furthermore, since they are electric motorcycles, they are environmentally friendly, silent, and simple to maintain.

If you detect a technical problem or you have any questions or queries about our products, please contact your nearest official TORROT dealer at www.torrot.com. You can also write to us at info@torrot.com, stating the VIN number, your query or the problem you have detected and your contact details.

4.1. Quality

Designed with care and passion by our technicians, for riders' first steps and initiation into the world of motorcycling, KIDS are authentic miniaturized motorcycles. With these motorcycles, children will learn, progress and have fun, becoming great riders.

4.2. Environment

To make the riding more efficient and sustainable, avoid accelerating and/or braking suddenly.

These series of vehicles have been designed according to strict environmental criteria.

KIDS use recyclable materials, which make the product more than 95% recyclable. Moreover, the vehicle has been designed to be easily disassembled to make it easier to be recycled.

The end of the product's life should be managed through an authorized processing center.

4.3. Trial series ONE and TWO

They are motorcycles with special studded tires for trial riding. This model offers to young riders an ideal architecture for their first steps, with a motorcycle that is almost the same as those that the great riders use. Borne of the most genuine experience and developed by professional riders, who love this discipline. This Trial motorcycle can later become a Motocross or Supermotard with the special kit, keep it in mind!

4.4. Motocross series ONE and TWO

They are motorcycles with off-road tires for motocross. This model offers to young riders unbeatable sensations thanks to its top speed and acceleration. Its robust chassis, almost indestructible plastics and its power performance make it a unique motorcycle. This Motocross motorcycle can become a Trial or Supermotard with the special kit, keep it in mind!

4.5. Supermotard series ONE and TWO

They are motorcycles with road tires for Supermotard. This model offers to young riders unbeatable sensations thanks to its top speed and acceleration. Its performance makes it a unique motorcycle. This Supermotard motorcycle can later become a Trial or Motocross with the special kit, keep it in mind!



5. WARRANTY CONDITIONS

TORROT ELECTRIC EUROPA S.A. guarantees to the owner that only the original components of each new TORROT ELECTRIC vehicle show no defects in materials, nor in labour during the following specified periods:

5.1. Two (2) years [three (3) years for Spain & Portugal] warranty for

- Any original component or part of a TORROT ELECTRIC vehicle (KIDS and MUVI).
- MUVI batteries are warranted for two (2) years [three (3) years for Spain & Portugal] or 40,000 km within this period, as long as the use and maintenance conditions set out in the manual are observed.
- The batteries in our KIDS vehicles, as long as the use and maintenance conditions set out in the manual are observed.

This warranty applies only to TORROT ELECTRIC vehicles bought new from an authorized TORROT ELECTRIC EUROPA S.A. dealer or directly from the manufacturer via online and which were assembled by that dealer or the manufacturer at the time of purchase. This warranty does not cover unauthorized parts or parts fitted by companies not explicitly authorized by TORROT ELECTRIC EUROPA S.A.

5.2. Limited repair

Unless decided otherwise, the only repair under the abovementioned warranty, or any implicit warranty, is limited to replacing defective parts for others of equal or greater value in the original vehicle, which is entirely at TORROT ELECTRIC's discretion. This warranty applies from the date of purchase and is applicable only to the original owner and is non-transferable, except for the MUVI electric scooter (see [warranty transfer](#) section).

Under no circumstances shall TORROT ELECTRIC be liable for direct, incidental or consequential damages, including, without limitation, damages for personal injuries, property damages or financial losses, be it on the basis of contract, warranty, negligence, product liability or any other theory.

5.3. Exclusions

The foregoing warranty, or any implicit warranty granted by TORROT ELECTRIC EUROPA S.A., does not cover:

- Normal wear and tear on parts such as tires, chains, drive sprockets, rear sprockets, brakes and hoses in situations where there are no assembly or material defects.
- Vehicles maintained or repaired by people who are not authorized by the manufacturer or who are unconnected to TORROT ELECTRIC.
- Modifications from the condition in which the vehicle was originally supplied.
- The use of TORROT ELECTRIC vehicles for abnormal, competition, and/or commercial activities or for purposes other than those for which they were designed.
- Damage caused by not following the owner manual instructions.
- Damage to the paint finish derived from participating in competitions and/or training for such activities or events or as the result of exposure or the use of TORROT ELECTRIC vehicles in extreme conditions or weather.
- Damage caused by external agents such as chemical products, salt, rust, discoloration or natural deterioration.

- Logistical and labour costs incurred in making the replacement or change.

Except where provided for in this warranty and subject to all the additional warranties, TORROT ELECTRIC and its employees and agents shall not be held liable for losses or damages, of any kind (including incidental and consequential losses or damages caused by negligence or omission) derived from or related to any TORROT ELECTRIC vehicle.

TORROT ELECTRIC EUROPA S.A. does not offer any other warranty, whether explicit or implicit. All implicit warranties, including the warranties of marketability and suitability for a particular purpose, are limited in duration to that of the explicit warranties set out above.

Any claim under this warranty must be filed through an authorized TORROT ELECTRIC dealer or directly online or by postal mail to TORROT ELECTRIC Europa S.A. The original purchase invoice which contains the date of purchase and VIN number is required before a warranty claim can be processed.

Warranty claims filed outside the country of purchase may be subject to additional fees and restrictions, and unless otherwise stated shall be covered solely and directly by the importer in the country or region outside Spain.

The term and details of the warranty may vary depending on the type of vehicle, battery and/or the country. This warranty grants specific legal rights; however, you may also have other rights that may vary by place. This warranty does not affect the rights established by the law.

5.4. Appendices

5.4.1. Online warranty registration

To validate and activate the warranty, the vehicle must be registered by the dealer or importer.

5.4.2. Transfer of the warranty (only MUVI)

The transfer of the warranty shall apply to the new user when they show they have concluded the change of ownership of the vehicle according to the laws in force in each country, binding the manufacturer in Spain and the importer in all other countries.

5.4.3. The user's liability

TORROT ELECTRIC EUROPA S.A. asks the user to meet certain requirements of good maintenance and use of its vehicles to be able to support a warranty claim properly. During the warranty term, your vehicle must only be serviced by TORROT ELECTRIC EUROPA, TORROT ELECTRIC importers or authorized official dealers. You are responsible for keeping your vehicle in good condition and to not subject it to greater stresses than those of ordinary use. During the validity period of the warranty, you must pass all the mandatory periodic technical inspections as indicated in the owner's manual in each TORROT ELECTRIC vehicle model. Otherwise, the warranty would be automatically invalidated.

The owner of the TORROT ELECTRIC vehicle accepts and understands that, in purchasing a TORROT ELECTRIC vehicle, the warranty does not cover repairs for damage caused by misuse, abuse, accident or neglect, nor does it cover units with the following characteristics:

- Specifications altered from those in its original configuration, as specified in the technical datasheet, manual or on the website www.torrot.com



- Vehicles used in competition, where that refers to time trials, competing with another vehicle or any other application involving abnormal stress.
- Vehicles lacking proper maintenance, cleaning or where the relevant mandatory periodic services detailed in the owner's manual according to each model have not been carried out.
- Vehicles where the distance counter (odometer), or any other electronic component (controller, electronics...) has been altered.
- Vehicles that are rented out.
- Observe the maximum load weight authorized for each vehicle, as stated in the owner's manual and in the technical characteristics in any offline and online TORROT ELECTRIC EUROPA S.A. product catalogue.
- Parts that wear out due to natural use, such as: batteries, brake calipers and pads, secondary transmissions, tires, upholstery, electric components, suspension elements, etc.
- Electrical/electronic circuit altered by modifying its original performance that are not the original or not explicitly authorized by TORROT ELECTRIC Europe S.A.
- Batteries in which an unauthorized or unofficial charger has been used, and batteries in which there has been overcharging or uncontrolled charging.

This warranty does not cover the cost of the mandatory periodic maintenance services, nor that of the routine services specified for each model in the owner's and maintenance manual.

For any problem that may arise in your vehicle, please write to info@torrot.com; state the VIN number, the problem detected, your name and a contact telephone number. Our technicians will quickly get in touch with you, and after a telephone pre-assessment, they will determine the procedure to follow as soon as possible.

6. LOCATION OF COMPONENTS

Below are the vehicles parts which this manual refers.

For all the pieces and spare parts for the vehicle, please contact your nearest official TORROT dealer.

No.	NAME	No.	NAME
1	Front wheel axle	30	Rear wheel rim
2	Front brake disc	31	Rear tire
3	Front brake caliper	32	Rear sprocket
4	Front rim	33	Rear wheel axle
5	Front tire	34	Front number plate
6	Fork outer tube	35	Handlebar
7	Fork inner tube	36	Speed and power limiting device
8	Front mudguard	37	Lateral plastic brackets*
9	Left side plastic*	38	Motor
10	Right side plastic*	39	Controller
11	Key switch	40	Swingarm axle
12	Chassis	41	Throttle
13	Right side guard	42	Front brake lever
14	Left side guard	43	Front brake lever regulator
15	Seat*	44	Front brake fluid reservoir
16	Battery	45	Start button
17	Rear mudguard	46	Battery charge level indicator
18	Left footpeg	47	Rear brake lever
19	Right footpeg	48	Rear brake lever regulator
20	Rear shock absorber	49	Rear brake fluid reservoir
21	Rear shock absorber guard	50	Man overboard device
22	Chain tensioner	51	Triple clamp
23	Chain	52	Steering axle
24	Chain guard	53	Steering bearings
25	Sprocket guard	54	Radial adjustment bushing
26	Swingarm	55	Fork dust seals
27	Side stand	56	Battery compartment
28	Rear brake disc	57	Battery compartment connector
29	Rear brake caliper	(*)	Only Motocross and Supermotard models



6.1. Trial

There may be slight differences between the images and series ONE and TWO.

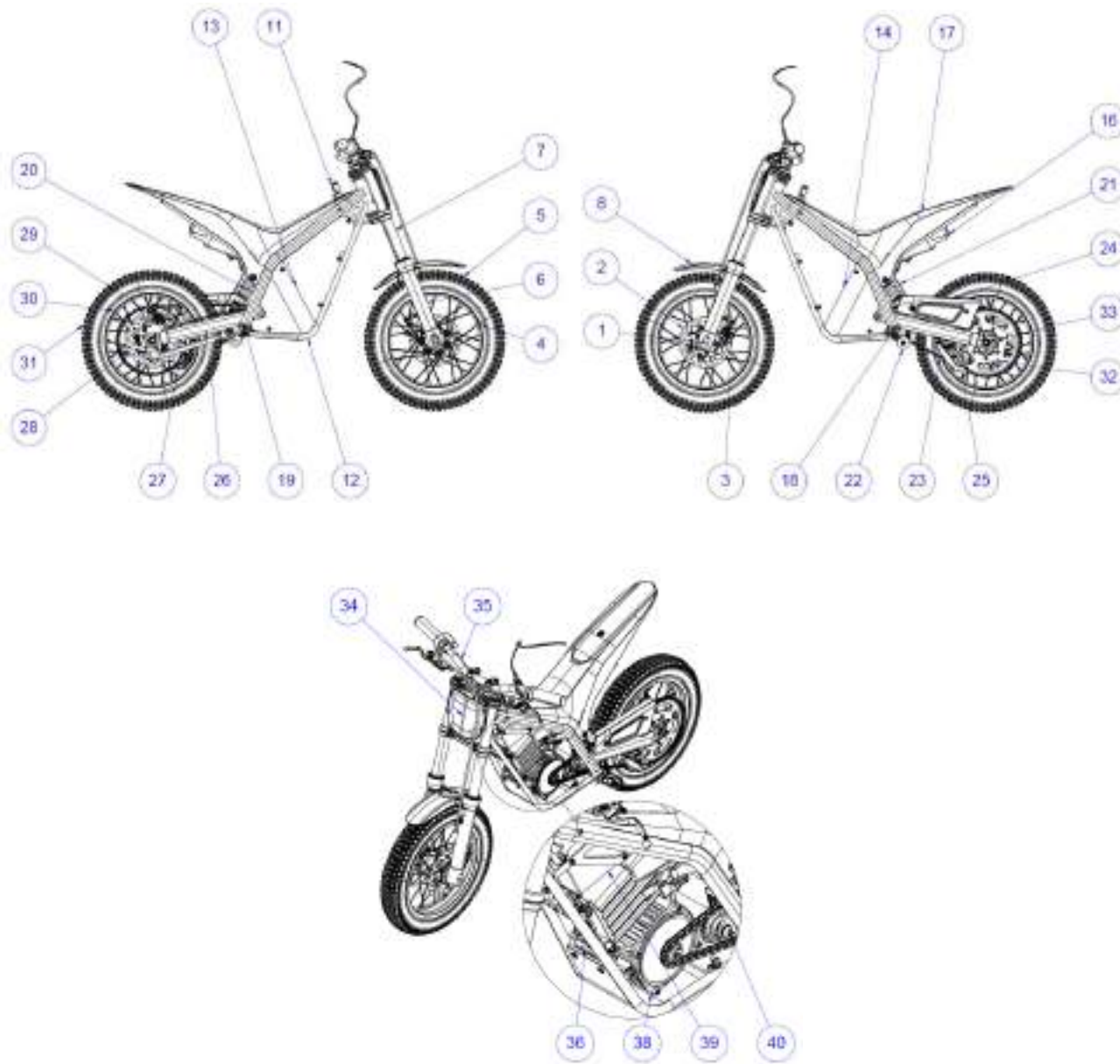

6.2. Motocross

There may be slight differences between the images and series ONE and TWO.

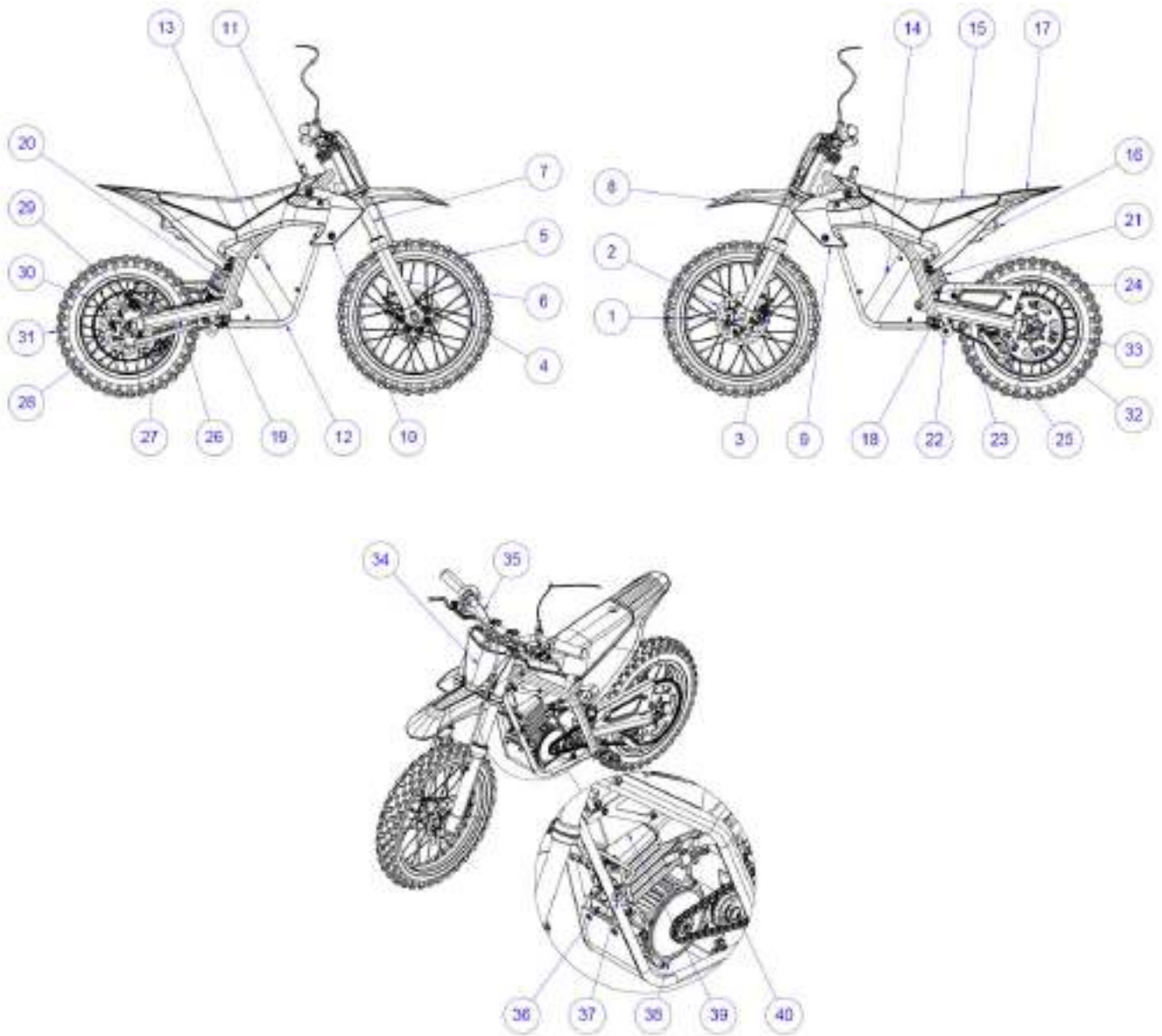



6.3. Supermotard

There may be slight differences between the images and series ONE and TWO.

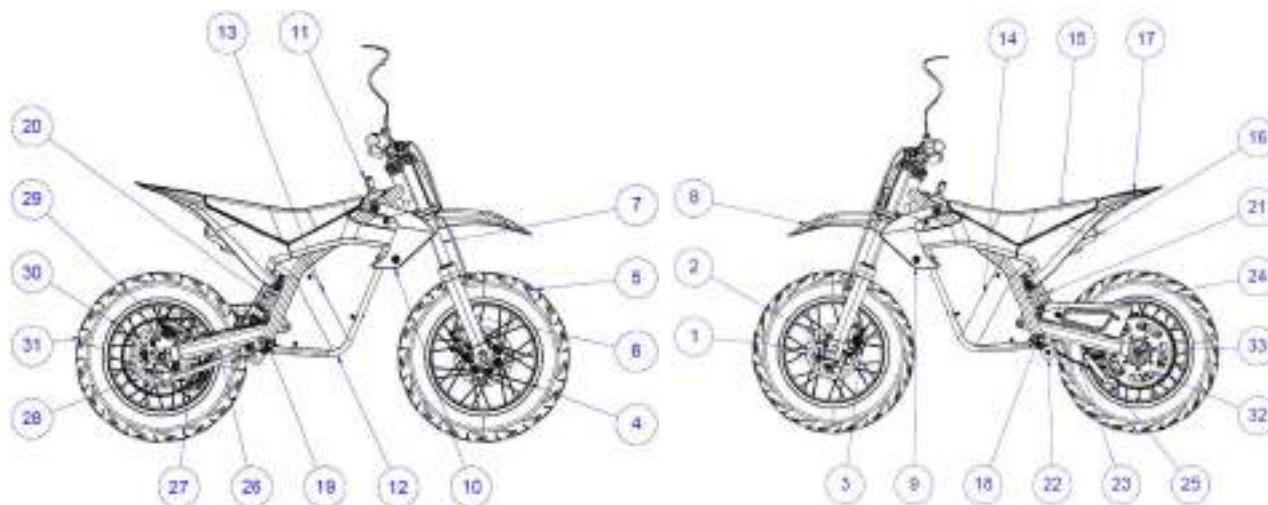

6.4. Other components

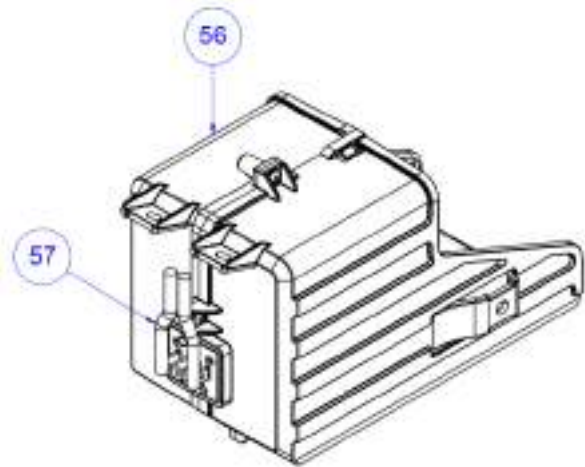
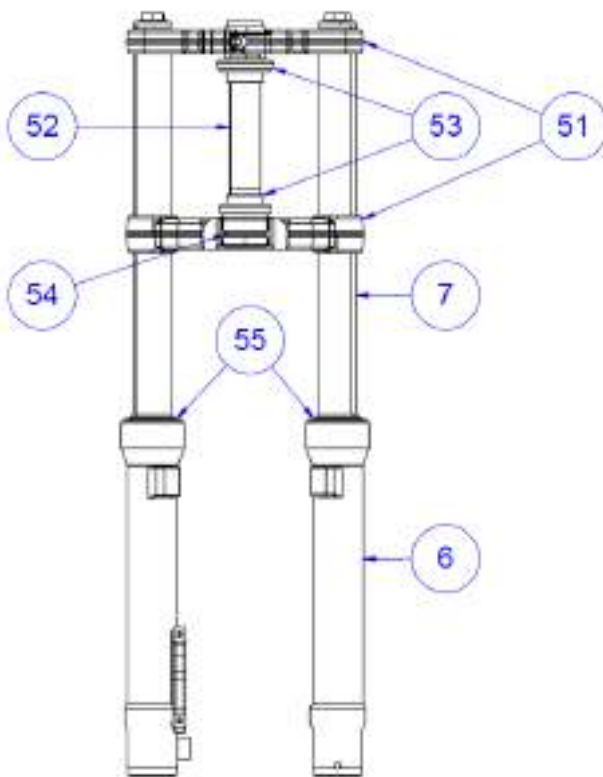
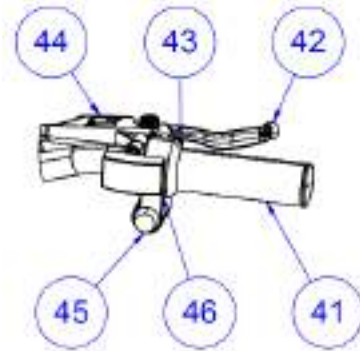
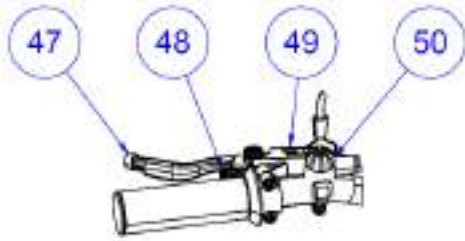



7. TECHNICAL SPECIFICATIONS

7.1. ONE Trial

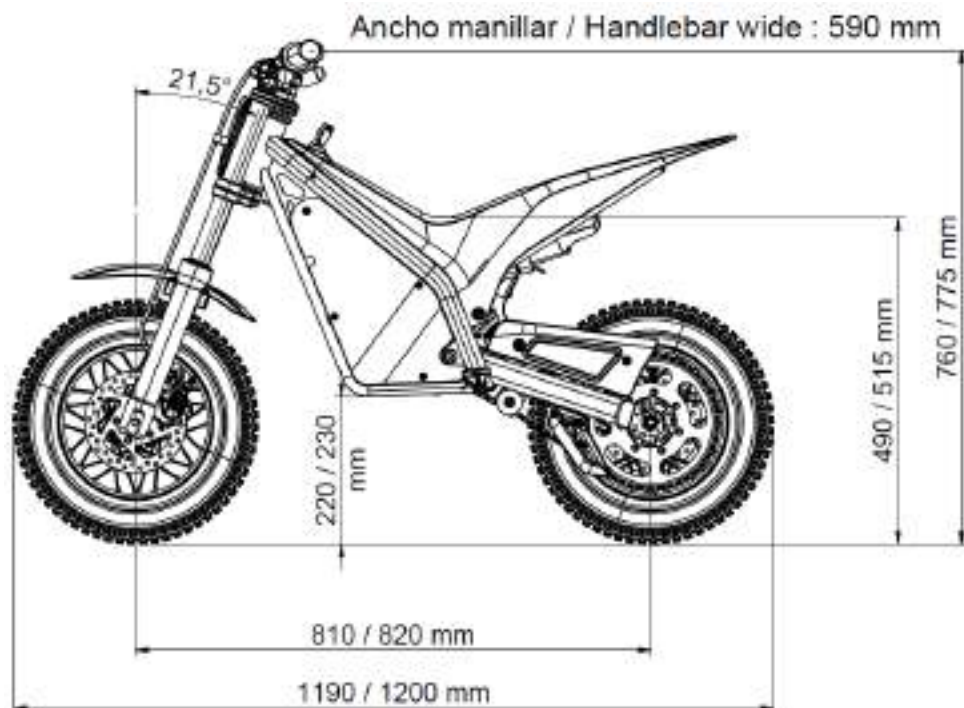

(*) Approximate dimensions. There may be differences between the vehicles and the dimensions contained in this manual.

Chassis	Tubular - Steel
Front suspension	Hydraulic fork 95mm travel
Rear suspension	Gas shock absorber with pre-load adjustment 85mm travel
Brakes	Front: 160 mm hydraulic Rear: 160 mm hydraulic
Battery	Swappable 46.8V / 6.6Ah / 309Wh / 13S 3P
Motor Controller	48V / programmable parameters using the APP: speed, power, throttle response and motor retention (regeneration)
Motor	Maximum power of 840W
Rims	Front: 10" x 1.60" Rear: 10" x 1.60"
Tires	Front: TORROT Trial 10" Rear: TORROT Trial 10"
Weight with battery	30Kg
Maximum rider weight	30Kg
Charger	54.6V / 2A (≈4 hours to fully charged)
Other functionalities	Bluetooth parental control and power management APP. Speed and power limiting device. Vehicle height adjustable to two positions.

7.2. TWO Trial

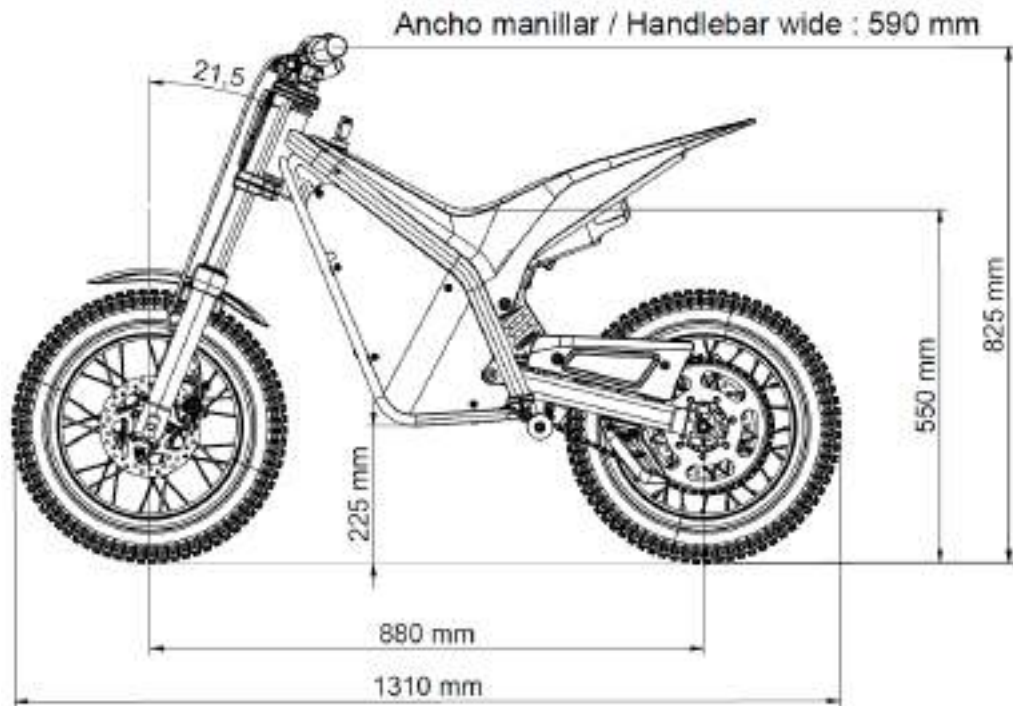

(*) Approximate dimensions. There may be differences between the vehicles and the dimensions contained in this manual.

Chassis	Tubular - Steel
Front suspension	Hydraulic fork 95mm travel
Rear suspension	Oil shock absorber with pre-load adjustment 125mm travel
Brakes	Front: 160 mm hydraulic Rear: 160 mm hydraulic
Battery	Swappable 46.8V / 8.8Ah / 412Wh / 13S 4P
Motor Controller	48V / programmable parameters using the APP: speed, power, throttle response and motor retention (regeneration)
Motor	Maximum power of 1500W
Rims	Front: 12" x 1.60" Rear: 12" x 1.60"
Tires	Front: TORROT Trial 12" Rear: TORROT Trial 12"
Weight with battery	33Kg
Maximum rider weight	30Kg
Charger	54.6V / 2A (≈5 hours to fully charged)
Other functionalities	Bluetooth parental control and power management APP. Speed and power limiting device.



7.3. ONE Motocross



(*) Approximate dimensions. There may be differences between the vehicles and the dimensions contained in this manual.

Chassis	Tubular - Steel
Front suspension	Hydraulic fork 95mm travel
Rear suspension	Gas shock absorber with pre-load adjustment 85mm travel
Brakes	Front: 160 mm hydraulic Rear: 160 mm hydraulic
Battery	Swappable 46.8V / 6.6Ah / 309Wh / 13S 3P
Motor Controller	48V / programmable parameters using the APP: speed, power, throttle response and motor retention (regeneration)
Motor	Maximum power of 840W
Wheels	Front: 10" x 1.60" Rear: 10" x 1.60"
Tires	Front: Michelin Starcross 10" 2.50 Rear: Michelin Starcross 10" 2.50
Weight with battery	31.5Kg
Maximum rider weight	30Kg
Charger	54.6V / 2A (≈4 hours to fully charged)
Other functionalities	Bluetooth parental control and power management APP. Speed and power limiting device. Vehicle height adjustable to two positions.

7.4. TWO Motocross

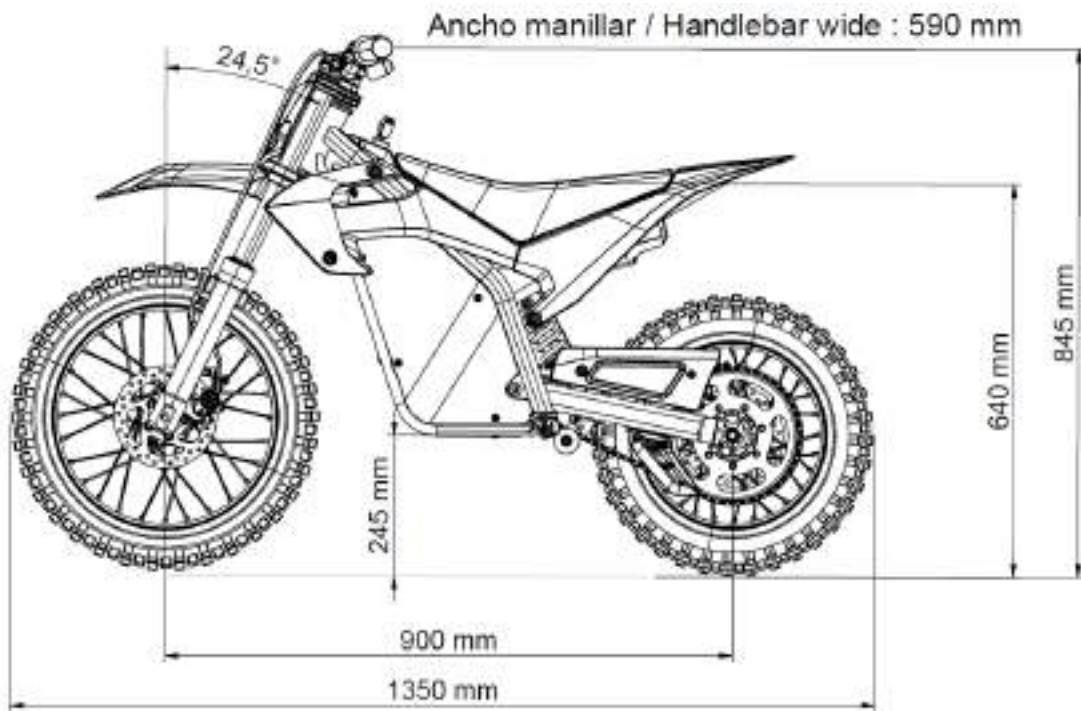

(*) Approximate dimensions. There may be differences between the vehicles and the dimensions contained in this manual.

Chassis	Tubular - Steel
Front suspension	Hydraulic fork 95mm travel
Rear suspension	Oil shock absorber with pre-load adjustment 125mm travel
Brakes	Front: 160 mm hydraulic Rear: 160 mm hydraulic
Battery	Swappable 46.8V / 8.8Ah / 412Wh / 13S 4P
Motor Controller	48V / programmable parameters using the APP: speed, power, throttle response and motor retention (regeneration)
Motor	Maximum power of 1500W
Wheels	Front: 14" x 1.60" Rear: 12" x 1.85"
Tires	Front: Michelin Starcross 60/100-14 Rear: Michelin Starcross 80/100-12
Weight with battery	35Kg
Maximum rider weight	30Kg
Charger	54.6V / 2A (≈ 5 hours to fully charged)
Other functionalities	Bluetooth parental control and power management APP. Speed and power limiting device.



7.5. ONE Supermotard

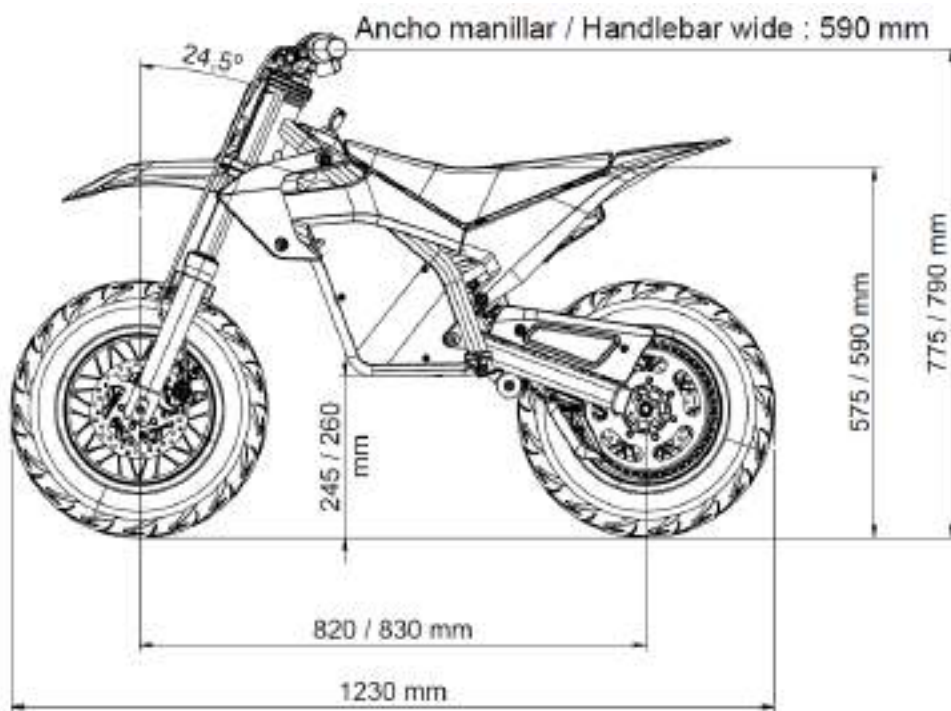

(*) Approximate dimensions. There may be differences between the vehicles and the dimensions contained in this manual.

Chassis	Tubular - Steel
Front suspension	Hydraulic fork 95mm travel
Rear suspension	Gas shock absorber with pre-load adjustment 85mm travel
Brakes	Front: 160 mm hydraulic Rear: 160 mm hydraulic
Battery	Swappable 46.8V / 6.6Ah / 309Wh / 13S 3P
Motor Controller	48V / programmable parameters using the APP: speed, power, throttle response and motor retention (regeneration)
Motor	Maximum power of 840W
Wheels	Front: 10" x 1.60" Rear: 10" x 1.60"
Tires	Front: Michelin Citygrip 90/90-10 Rear: Michelin Citygrip 90/90-10
Weight with battery	33Kg
Maximum rider weight	30Kg
Charger	54.6V / 2A (≈4 hours to fully charged)
Other functionalities	Bluetooth parental control and power management APP. Speed and power limiting device. Vehicle height adjustable to two positions.

7.6. TWO Supermotard

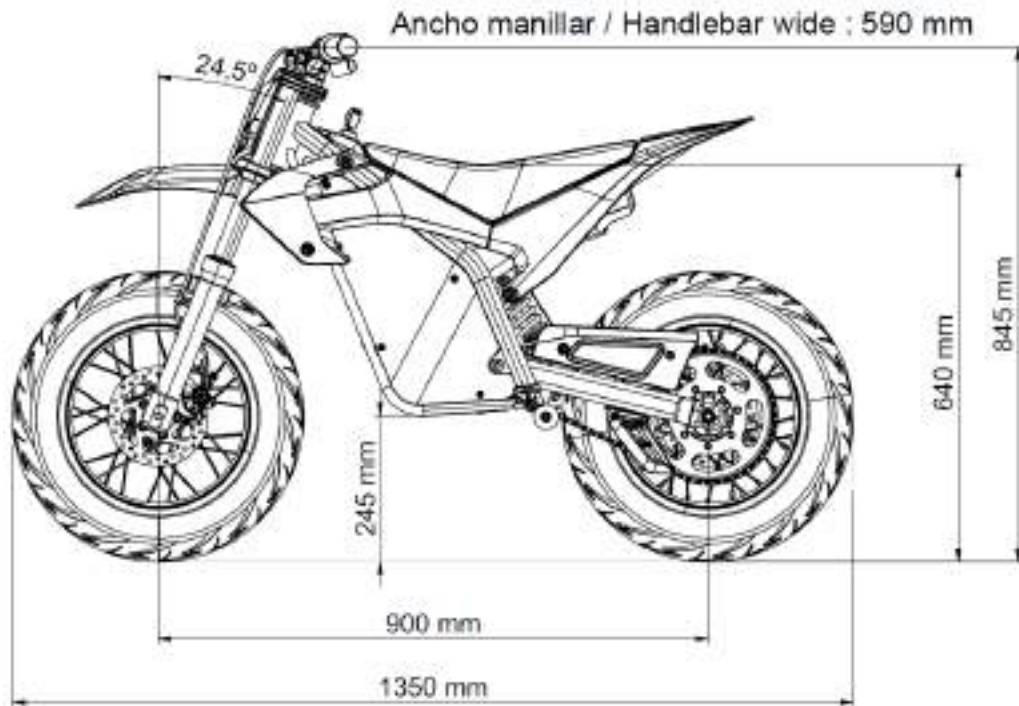

(*) Approximate dimensions. There may be differences between the vehicles and the dimensions contained in this manual.

Chassis	Tubular - Steel
Front suspension	Hydraulic fork 95mm travel
Rear suspension	Oil shock absorber with pre-load adjustment 125mm travel
Brakes	Front: 160 mm hydraulic Rear: 160 mm hydraulic
Battery	Swappable 46.8V / 8.8Ah / 412Wh / 13S 4P
Motor Controller	48V / programmable parameters using the APP: speed, power, throttle response and motor retention (regeneration)
Motor	Maximum power of 1500W
Wheels	Front: 12" x 1.85" Rear: 12" x 1.85"
Tires	Front: Michelin Citygrip 90/90-12 Rear: Michelin Citygrip 90/90-12
Weight with battery	37Kg
Maximum rider weight	30Kg
Charger	54.6V / 2A (≈ 5 hours to fully charged)
Other functionalities	Bluetooth parental control and power management APP. Speed and power limiting device.



8. USE AND MAINTENANCE

Do not force the vehicle abnormally during use.

Avoid unnecessary blows and vibrations on your vehicle.

Avoid accelerating the vehicle while braking.



It is prohibited for persons not explicitly authorized by the manufacturer to handle or repair any electric element external to the battery.

It is prohibited for persons not explicitly authorized by the manufacturer to handle or repair the battery.



Avoid direct contact between your vehicle's electric system and water, mud or similar materials. If water should accidentally get into any of the vehicle's electrical elements, disconnect it and wait for it to dry naturally before using it again.

The vehicle can be used at an ambient temperature of between -15 and 50°C. If it is used in environments with temperatures outside this range, some components of the vehicle may suffer irreparable damage.

8.1. Chassis

For the two KIDS series (ONE and TWO), there are two different chassis for better adaptation to the size of young riders according to their ages. Both chassis are robust, lightened steel structures, and they are powder coated to protect them from environmental conditions and to ensure a long lifetime.

The chassis does not require maintenance, although it must be inspected immediately after suffering an accident or fall to ensure there are no cracks or breakages and that it is not deformed.



If the chassis shows any kind of damage or signs of deterioration, it must be replaced.

8.2. Swingarm

Like the chassis, the swingarm is also powder coated.

In the case of series ONE model, the swingarm allows two different positions for the rear shock absorber. This allows you to adjust the clearance between the seat and the ground to admit a broader range of rider heights.

The swingarm must be inspected immediately after suffering an accident or fall to ensure there are no cracks or breakages and that it is not deformed.



The adjustment of the seat's height is a delicate operation that may entail safety problems for the structure of the vehicle. To modify the height of the seat, please contact your nearest official TORROT dealer.

8.2.1. Maintenance of the swingarm

Periodically inspect the bronze swingarm axle bushings.

Periodically inspect the clearance between the bronze bushings and the swingarm axle. To do this, lift the rear wheel. Try to move the swingarm up and down. No clearance should be appreciated.

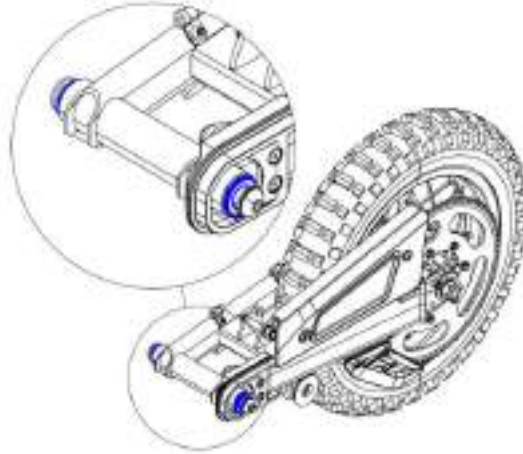

If the swingarm or its bushings show any kind of damage or signs of deterioration, they must be replaced.

This maintenance is a delicate operation that may involve safety problems in the structure of the vehicle. To do this, please contact your nearest official TORROT dealer.

8.3. Lithium-ion batteries or accumulators

KIDS ONE motorcycles have a lithium-ion battery with a rated voltage of 46.8V and a capacity of 6.6Ah (309Wh of energy) that powers the motor controller. In the KIDS TWO, the rated voltage of the battery is 46.8V and its capacity is 8.8Ah (412Wh of energy).

This type of battery does not have the so-called “memory effect”, so it can be charged even if it is not fully discharged without affecting its capacity.



Do not use KIDS battery for any purpose other than that for which it was explicitly designed. Moreover, the batteries are not interchangeable from one series to the other (ONE and TWO).

The battery consists of high energy density lithium-ion cells. It must never be handled under any circumstances.

It is prohibited for persons not explicitly authorized by TORROT to inspect, repair or replace the battery or any of its elements.

Avoid any direct blow to the battery during handling or transit.



If the battery or its connectors show any kind of damage or signs of deterioration, please contact your nearest official TORROT dealer.

If the battery compartment or its connectors show any kind of damage or signs of deterioration, they must be replaced. Please contact your nearest official TORROT dealer to get the spare part.



Do not leave the battery fully charged for long periods since it may deteriorate. Follow the instructions in the *Storage of the vehicle* section.

Never connect or disconnect the battery with the vehicle switched on. The start button and the key switch must be in the off position.

Before the first use, you must fully charge the battery.

It is recommended that the battery is fully charged before each use. To lengthen its lifetime, do not charge the battery partially, and always charge up to the maximum limit imposed by the charger.

Batteries suffer a small self-discharge, which is a natural feature of the battery. In the event of long periods of inactivity, connect the charger from time to time and perform charge-discharge cycles as indicated in the *Storage of the vehicle* section.

Your battery has internal protections that can act automatically in the event of abnormal operation. If the battery does not work properly, please contact your nearest official TORROT dealer.

8.3.1. Charging the battery



It is absolutely prohibited to use any kind of charger that was not supplied directly by the manufacturer or by an authorized dealer.

Never cover the charger or allow it to become wet.



During continuous use, the charger may become hot. Never touch the charger during or just after charging the battery.

Keep the battery and electric components away from children during the battery charging process.

Do not leave the battery permanently connected to the charger to prevent electric risks.

The battery must be charged in temperatures between +0°C and 40°C and with a humidity lower than 75%.



Never disconnect the charger connectors by pulling the cables: it must be held by the rigid part of the connectors.

Never connect the charger connectors using excessive force.

Components needed to charge the battery:

- Battery (A)
- Charger (B)
- Charger cable for connecting to the house mains (C)

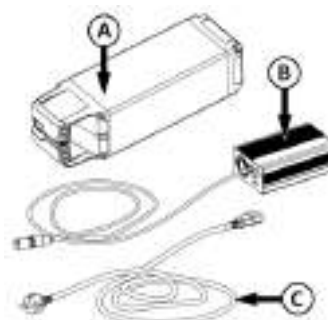

Charging of the battery outside the vehicle

One of the points that differentiates this vehicle from others is that its batteries are easy to remove and transport to charge them wherever you like. Moreover, this option allows you to have more than one battery so that you can change it when it is depleted. Thus, you will not have to wait to charge the battery to continue using the motorcycle.



Never remove the battery when the motorcycle is switched on.

Follow the following steps to extract and charge the battery:

1. Ensure that the motorcycle is switched off. See the section *Stopping the vehicle*.
2. Loosen the Velcro® strap that fastens the battery (1).
3. Pull the battery out from the rear of the motorcycle. Pay special attention when handling the battery, it is a component with a considerable weight, try to remove it carefully and avoid hitting it.
4. Remove the protective rubber cap from the battery connector (2).
5. Connect the charger cable with its three-pin connection to the battery (3).
6. Plug the cable (4) into the charger and then the other end into the 100-240V house mains (5). You will see that LED 2 on the charger turns red to indicate that the battery is charging.

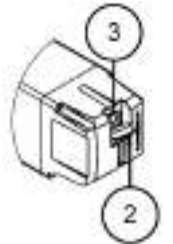

	LED 2	LED 1
Charger switched on	Green	Red
Battery charging	Red	Red
Battery fully charged	Green	Red

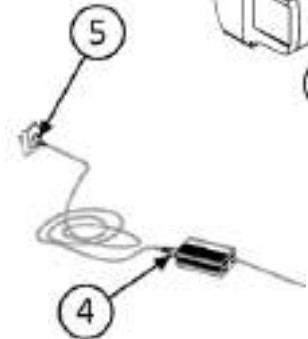

The LED 2 will turn green when the battery is fully charged. It will take about 4 hours to fully charge in the case of a series ONE battery, and 5.5 hours for a full charge in the case of a KIDS TWO series.

To lengthen the lifetime of your battery, do not charge it only halfway. Wait until the LED 2 is green!

After charging the battery, follow the following steps to install it in the vehicle:

1. Unplug the charger from the socket (5) and, only then, disconnect the battery charger (3), fit the battery connector's protective rubber cap (2).
2. Ensure that the motorcycle is switched off. See the section *Stopping the vehicle*.
3. Ensure that the battery compartment, its connector and the battery itself are completely dry.
4. Slide the battery inside through the rear of the motorcycle. Remember to insert the battery properly and in the correct direction. Pay special attention when handling the battery, it is a component with a considerable weight, try to insert it carefully and avoid hitting it.
5. Tighten the Velcro® strap to fasten the battery (1).



Remember always to cover the battery charging port with the protective rubber cap to prevent dirt from getting in.

Charging of the battery connected into the vehicle



For safety and to prevent the motorcycle from being able to be handled with the charger connected, we advise you to charge the battery once it has been removed from the vehicle. However, if you wish to charge it in the vehicle, you must put the key switch in the off position and remove the key from it. During the entire charging process, the motorcycle must remain switched off.

Follow the following steps to charge the battery:

1. Ensure that the motorcycle is switched off. See the section *Stopping the vehicle*. Moreover, the key must be removed from the key switch.
2. Loosen the Velcro strap holding the battery (1) and remove the protective rubber cap from the battery connector (2).
3. Connect the charger cable to the battery using the three-pin connector (3).



4. Plug the cable (4) into the charger and then the other end to the 100-240V 50-60Hz house mains (5). You will see that LED 2 on the charger turns red to indicate that the battery is charging.

	LED 2	LED 1
Charger switched on	Green	Red
Battery charging	Red	Red
Battery fully charged	Green	Red

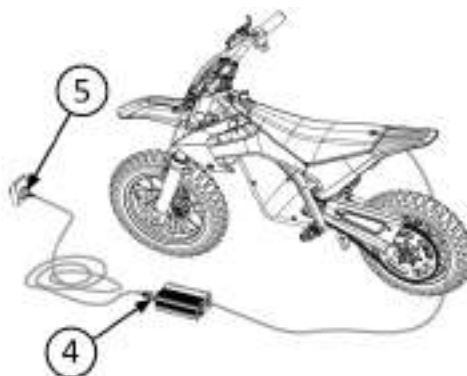

The LED 2 will turn green when the battery is fully charged. It will take about 4 hours to fully charge in the case of a battery of the KIDS ONE model, and 5.5 hours for a full charge in the case of a battery of the KIDS TWO model.

After charging the battery follow the steps shown below:

1. Unplug the charger from the socket (5) and, only then, disconnect the battery charger (3)
2. Refit the battery charging connector's protective rubber cap (2)
3. Do not forget to re-fasten the battery using the Velcro strap (1).

Your KIDS motorcycle will now be ready to ride again.



Remember to always cover the battery charging port with the protective rubber cap to prevent dirt from getting in.

8.4. Motor

KIDS motorcycles are equipped with a brushless AC motor which has a peak power of 1500W in the case of KIDS TWO, and 840W in the case of the KIDS ONE. Using the Bluetooth APP it is possible to limit the maximum power of the vehicle, as well as customize the throttle response.



Do not put your hand near the chain, sprocket, or any other moving part while the motor is turning. During continued use, the motor can become hot, reaching high temperatures. Do not touch the motor during or just after using the vehicle in any case.

8.4.1. Maintenance of the motor

Motors have considerably less maintenance than internal combustion engines.

Check periodically the bearings condition. To do this, raise the rear wheel off the ground. Rotate the rear wheel using the hand. No noise must be heard coming from the motor.



The replacement of the motor bearing is a delicate operation. To do this, please contact your nearest official TORROT dealer.

8.5. Brakes

KIDS motorcycles are equipped with a hydraulic brake disc system on both the front and rear wheels.



During continuous use, the brakes may become hot. Do not touch the brakes during or just after using the vehicle under any circumstances.

Before each use of the motorcycle, check that both the front and the rear brakes are actuated by activating the right (1) and left (2) brake lever respectively, while attempting to move the motorcycle.



If the brake discs or pads accidentally contaminates with oil, grease or any other uncontrolled chemical element, these parts must be replaced.



If any element of the braking system suffers a blow, it must be replaced.

The replacement of the braking system elements is a delicate operation that may involve safety problems in the vehicle's braking system. To do this, please contact your nearest official TORROT dealer.

If the brake lever is too close or too far to the rider, you can adjust it by turning the rear brake lever regulator in one direction (3 and 4) to bring the lever closer to or move it further from the handlebar.

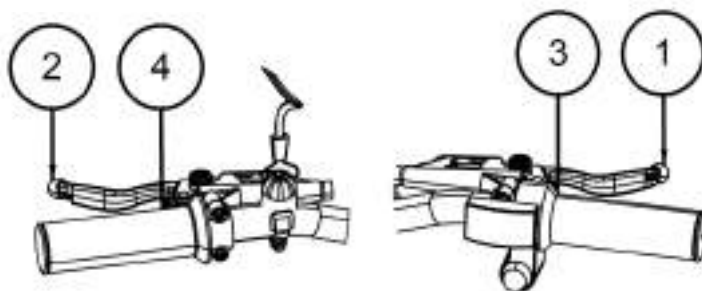

8.5.1. Brake maintenance

Periodically inspect the brake pads. If less than 2mm of usable pad remains, they must be replaced.

The brake discs must be cleaned periodically with products designed specifically for that purpose. Never use products such as soap, grease remover or other chemical products that are not specifically for that purpose.

If you detect that the brake lever has too much travel, the hydraulic brake circuit fluid must be bled and/or changed. This fluid must be replaced with a DOT 3 or DOT 4 from a sealed container. Under any circumstances replace it with another hydraulic fluid.



Periodically inspect the elements of the vehicle's braking systems. If the brake discs, calipers, hoses, pistons, levers and/or brackets show any damage or signs of deterioration, they must be replaced.

This maintenance is a delicate operation that may involve safety problems on the vehicle's braking system. To do this, please contact your nearest official TORROT dealer.

8.6. Forks and steering

The KIDS motorcycles' hydraulic forks are composed by the outer and the inner tubes. They are specifically designed for each model. Thanks to this, a different geometry is achieved for each format, hence the rider's sensations are unique.



During continuous use, the forks may become hot. Do not touch the forks during or just after using the vehicle under any circumstances.

8.6.1. Maintenance of forks and steering

To keep the forks in good condition, change the forks' oil after every 60 hours of vehicle use or if you detect that the shock absorption is not working properly. Use 100ml of SAE 10 oil to each fork leg to change the oil.

Check periodically that the handlebar rotates freely. To do it, raise the front wheel off the ground. Turn the handlebar from one side to the other. It should not be difficult to move it at any point along the steering travel.

Inspect periodically the clearance of the steering bearings. To do so, raise the front wheel off the ground and put the steering straight. Try to move the forks back and forth. No clearance should be appreciable.



Inspect periodically the elements of the vehicle's front suspension. If the forks, the triple clamps and/or the steering bearings show any kind of damage or deterioration signs, they must be replaced. This maintenance is a delicate operation that may involve safety problems on the structure and steering of the vehicle. To do this, please contact your nearest official TORROT dealer.

Before each use of the motorcycle, clean the suspension fork dust seals (1).



8.7. Rear shock absorber

The KIDS ONE motorcycles are equipped with a gas shock absorber, while the KIDS TWO motorcycles are equipped with an oil shock absorber. Both models are designed to give riders the best sensations.



During continuous use, the shock absorber may become hot. Never under any circumstances touch the shock absorber during or just after using the vehicle.

You can adjust the pre-load of the shock absorber (1) to adapt the rear suspension to the rider's weight and preferences. To do this, turn the nut (2) clockwise to compress the spring or anti-clockwise to decompress it. Compressing the shock absorber's spring increases the pre-load, making the suspension feeling harder.

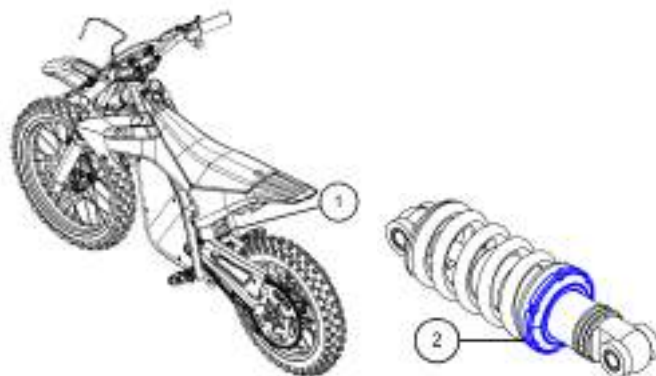

Please contact your nearest official TORROT dealer for different spring stiffness's:

- KIDS ONE: 550lb/in (ref. BE30010TT-CKJ-1) or 750lb/in (ref. BE30011TT-CKJ-1)
- KIDS TWO: 450lb/in (ref. BE30010TT-CKK-1) or 650lb/in (ref. BE30011TT-CKK-1)

8.7.1. Maintenance of the rear shock absorber



Inspect periodically the rear shock absorber and/or its spring. If the shock absorber or the spring show any kind of damage or signs of deterioration, they must be replaced.

This maintenance is a delicate operation that may involve safety problems in the structure of the vehicle. To do this, please contact your nearest official TORROT dealer.

8.8. Transmission

The lifetime of the chain depends on whether it is properly lubricated and adjusted. Poor maintenance may cause premature wear and tear and/or damage to the chain, rear sprocket and/or to the drive sprocket.

Chain's tension varies according to the weight of the rider and whether the rider is sitting or standing on the motorcycle. To check this properly, the habitual rider must be sitting on the motorcycle while chain's tension is checked.

Before each use of the motorcycle, check the clearance in the center of the lower section of the chain (1) as shown in the following image. The clearance must allow vertical movement with your hand of between 10 and 20 mm.

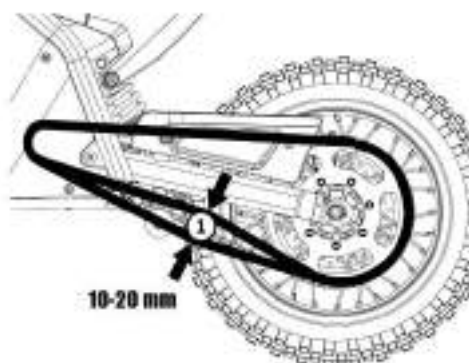

Rotate the rear wheel moving the tire with your hand, stopping at different positions to check the chain's clearance, always taking the measurements in the same place.



As you rotate the wheel, do not put your fingers near the chain, rear sprocket, drive sprocket or any other moving element.



8.8.1. Maintenance of the transmission

Clean and lubricate the chain periodically. Protect the braking system before applying the lubricant.

Inspect periodically the chain's clearance. If the chain's clearance is not within the recommended values, adjust its tension.



Periodically inspect the chain (1), the drive sprocket (2), the rear sprocket (3) and/or the chain slider (4). If the chain, the drive sprocket, the rear sprocket or the chain slider show any kind of damage or signs of deterioration, they must be replaced.

This maintenance is a delicate operation that may involve safety problems in the structure of the vehicle. To do this, please contact your nearest official TORROT dealer.

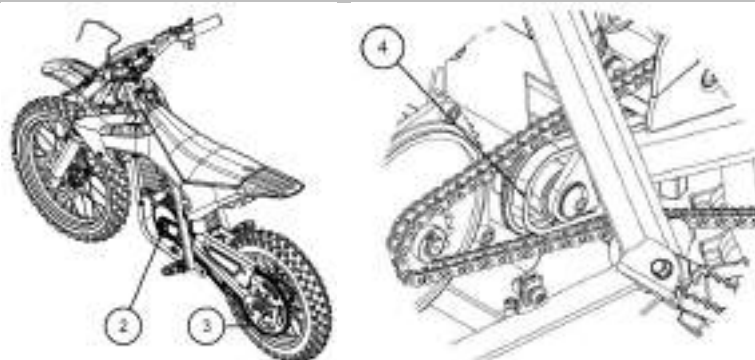

8.9. Rims and tires

Tires are the only elements in contact between the vehicle and the ground. In all riding conditions, safety depends on a relatively small area of contact with the ground, hence it is extremely important to maintain the pressure at the values recommended by the manufacturer and that the tires are kept in good condition.

Tires age even when they are not in use or when they are only used sporadically. Cracks in the tire or in the sidewalls, often accompanied by deformation of the tire, are an unequivocal sign of aging.

The spare rims and tires must be the same size and type as those specified by the vehicle's manufacturer. The tire type cannot be changed without the advice of the manufacturer of the tire or vehicle, and you must consider the effects of such change on the vehicle's safety and behavior.

Vehicle		Tire	Dimensions of the tire
ONE	Trial	Front tire	2.50-10 33J
		Rear tire	2.50-10 33J
	Motocross	Front tire	60/100 R10 33J
		Rear tire	60/100 R10 33J
	Supermotard	Front tire	90/90 R10 50J
		Rear tire	90/90 R10 50J
TWO	Trial	Front tire	2.50-12 38J
		Rear tire	2.50-12 38J
	Motocross	Front tire	60/100 R14 29M
		Rear tire	2.50-12 36J
	Supermotard	Front tire	90/90 R12 54P
		Rear tire	90/90 R12 54P

The recommended tire pressures are shown in the following table:

	Front tire	Rear tire
Trial	0.9	0.6-0.8
MX	1.0	1.2
SM	1.2	1.4

(*) All pressures in bars.



Used tires must not be installed if their prior history is not known.

If a tire is punctured, it is essential to stop as soon as possible. To prevent a possible fall, do not brake sharply.

A tire repair must only be done by a professional.

Check that the rims and tires are in good condition before each use of the motorcycle.

Check that the wheels are properly fastened before each use of the motorcycle.

8.9.1. Maintenance of the rims and tires



Periodically inspect the tire pressures. This operation must only be done when the tires are cold and never immediately after using them.

Periodically inspect the tension of the spokes to ensure their tension remains correct.

If the tires, rims, their spokes and/or their bearings show any kind of damage or signs of deterioration, they must be replaced.

This maintenance is a delicate operation that may involve safety problems in the structure of the vehicle. To do this, please contact your nearest official TORROT dealer.

8.10. Side stand

The motorcycle is equipped with a side stand to support the motorcycle when it is stopped.



Do not sit or rest on the motorcycle when it is resting on the side stand.



Do not start or move the motorcycle with the side stand unfolded.

Ensure that the side stand remains in its folded away position before switching on the motorcycle.

The side stand does not have a specific maintenance. If the side stand shows any kind of damage or signs of deterioration, it must be replaced.

Lubricate the side stands join after cleaning the vehicle.



8.11. Speed and power limiting device

This motorcycle is equipped with a speed and power limiting device that restricts the vehicle's maximum speed and power. Use this device until the rider is used to riding the motorcycle.



It is important for the safety of the rider that the speed and power limiting device is set according to him/her level of skill, experience and maturity.

You must also bear the requirements for safe use by an experienced rider in mind to adjust the speed and power limiting device. For example:

- The maximum speed that can be reached with a certain setting may vary considerably on different surfaces; the power requirements on soft ground will be greater than those required on hard ground.
- Reducing the performance unnecessarily may affect the ability to go up slopes or overcome obstacles, making it unstable.

8.11.1. Speed limiting adjustment protocol

To deactivate/activate the speed and power limiting device on the motorcycle, follow the next steps, always in the stated order:

1. The speed and power limiting device is at the front of the motorcycle. To access it, you must move away the protective plastic (1) to one side by the lower zone.
2. Once you have moved the protective plastic, you can access to the speed and power limiting device (2).

This device has two positions:

- "50%" (3) in this position, the device limits the vehicle's maximum speed to less than 16 km/h, and it limits the vehicle's power to half of that set using the smartphone application (see the section [Connect using the Bluetooth APP](#)).
- "100%" (4): in this position, both the vehicle's power and its maximum speed depend on the parameters set in the smartphone application (see the section [Connect using the Bluetooth APP](#)). Adjust the settings according to the rider's riding ability.

3. Once the speed and power limiting device has been adjusted to the desired position, insert again the protective plastic in the chassis slot.

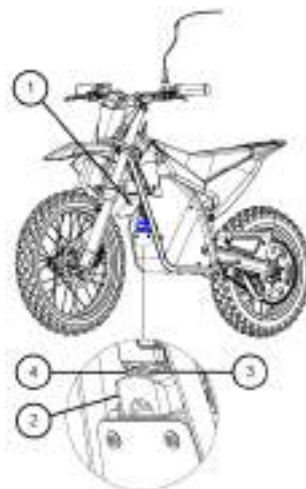

8.12. Man overboard device

The vehicle is equipped with a safety device called man overboard, which switches off the vehicle when it is disconnected.

The function of this device is to switch off the motorcycle in the event of falling off, thus preventing injury to the rider. Therefore, the device's strap must be securely attached to the rider's wrist, ensuring that it cannot be unintentionally removed from the rider's wrist and it does not squeeze the rider's wrist excessively.



Before using the vehicle, ensure the rider has the man overboard fitted properly.

8.13. Throttle and battery charge level indicator

The vehicle is equipped with a throttle which contains a battery charge level indicator.



Before each use, inspect the throttle to ensure it returns automatically. To do so, twist the throttle and then release it. The throttle must return quickly and automatically to its original position.

If the throttle shows any kind of damage, signs of deterioration and/or it does not return automatically, it must be replaced.

The battery charge level is indicated as in the following illustration:

This indicator shows the battery's voltage. Due to how this vehicle works, it is possible that with aggressive riding you will observe that the battery charge level varies. To see it more precisely, read it when the vehicle is stopped.

	100% LED: 54.6V - 48V
	75% LED: 48V - 46V
	50% LED: 46V - 44V
	25% LED: 44V - CUTOFF



9. MAINTENANCE SCHEDULE

Component	Check/Inspect	Adjust	Replace/Change	Clean	Grease/Lubricate
Chassis	Each ride	-	When it is damaged	-	-
Swingarm	Each ride	-	When it is damaged	-	-
Battery	Each month	-	When it is damaged	Each ride	-
Brakes	Each ride	As necessary	When it is damaged	Each ride	-
Forks	Each ride	-	-	Each ride	-
Steering	Each ride		When it is damaged	-	
Rear shock absorber	Each year	-	Every 2 years or when it is damaged	-	-
Transmission	Each ride	-	When it is damaged	Every 3 trips	Each time it is cleaned
Rims and tires	Each ride	-	When it is damaged	Every 3 trips	-
Side stand	Each ride	-	When it is damaged	Every 3 trips	Each time it is cleaned
Motor bearing	Each 100 hours	-	When it is damaged	-	-

10. TIGHTENING TORQUES

Below is a list of the vehicle's most important tightening torques:

TYPE	LOCATION	SIZE	TIGHTENING TORQUE (Nm)
NUT	Steering axle – Chassis	W1" 24G	30
SCREW	Brake Discs – Wheels	M6	12*
SCREW	Rear sprocket – Rear Wheel	M6	12*
SCREW-NUT	Motor – Chassis	M8	20
SCREW	Controller – Chassis	M4	5
SCREW	Swingarm – Chassis	M8	30**
SCREW	Bluetooth - Chassis	M4	5
SCREW	Handlebar – Bar mounts	M6	10
SCREW	Front brake caliper bracket – Fork	M6	10
SCREW	Front brake caliper	M6	10
SCREW-NUT	Top bracket shock absorber	M8	20
SCREW-NUT	Bottom bracket shock absorber	M8	20
SCREW	Bike stand	M8	20**
SCREW	Front wheel axle	M12	40
NUT	Rear wheel Axle	M12	40
SCREW	Brake levers – Handlebar	M5	8
SCREW	Throttle – Handlebar	M4	8
SCREW	Lateral Plastic Bracket – Chassis	M5	8
SCREW	Plastics – Chassis	M6	5
SCREW	Seat	M6	10
SCREW	Footpegs – Chassis	M6	10
SCREW	Triple clamp	M6	10
NUT	Fork bottom	M6	12

* Use low-strength threadlocker.

** Use medium-strength threadlocker.



Adhere to the tightening torques specified for the vehicle.



11. STARTING AND STOPPING THE VEHICLE

11.1. Inspection and care before each ride

Before initiating the start of the motorcycle, follow the next steps. Before doing so, ensure that the vehicle is fully switched off:

- With the motorcycle switched off, check that the throttle returns automatically (see the section Throttle and battery charge level indicator).
- Inspect the battery to ensure it has no dents, cracks, damage or leaks.
- Check that the battery charging connector protector is properly fitted.
- Ensure there is no water in the battery connectors, in the battery compartment or in its connector.
- Check that the front and rear braking system is working properly (see the section Brakes).
- Check that there is no element blocking the turning of the handlebar in both directions over its travel (see the section Forks and steering).
- Check the state of the rims and the tires (see the section Rims and tires).
- Inspect the vehicle's transmission (see the section Transmission).
- Clean the dust seals on the forks (see the section Forks and steering).

11.2. Starting the vehicle

To start the motorcycle, follow the steps below, always in the stated order:

1. Ensure the key switch (1) is in the off position (2), and that the start button (4) located at the right of the handlebar is also in the off position. Insert the battery into the battery compartment and fasten it with the Velcro® strap. See the section Charge the battery outside the vehicle.
2. Ensure that the man overboard device is connected to the vehicle and properly fitted on the rider's wrist.
3. Turn the key switch to the on position (3).
4. Put the start button on the throttle (4) to the on position. The button is in the on position when it is pressed, and in the off position when it is unpressed. You will hear a "Click" when you actuate it.
5. The battery charge level indicator will then light up (5).

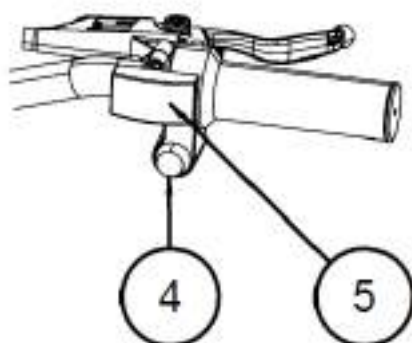
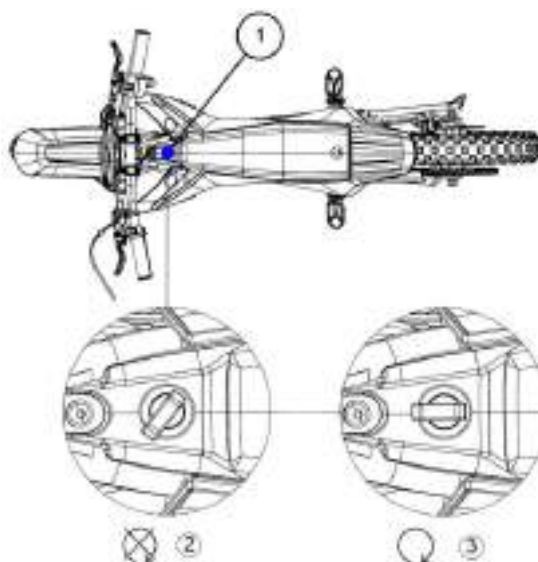



Your KIDS motorcycle will then be ready to be used.

Do not forget to fold away the side stand before starting the motorcycle.

To prevent injuries while riding, remove the key when the key switch is in the on position (3).

11.3. Stopping the vehicle

To stop the motorcycle, follow the next steps in the stated order:

1. Switch the throttles start button (1) to the off position. The on position corresponds to the pressed button, while the off position corresponds to the released button. You will then observe that the battery charge level indicator is switched off (2).

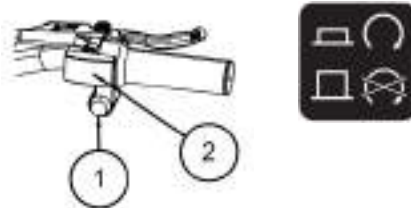

2. Go to the key switch located at the front of the motorcycle (3). Turn the key from the on position (4) to the off position (5); you will hear a “Click” when actuating it.

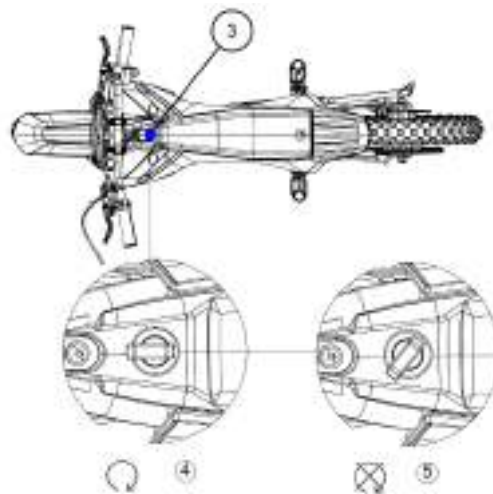

Do not forget to unfold the side stand to prevent the motorcycle from falling. Ensure that the side stand is resting on a flat and firm surface.



Never forget to carry out this maneuver. If this is not done, the motorcycle will continue to consume energy from the battery, which will cause it to self-discharge.

It is recommended to remove the battery so that the self-discharge is kept as low as possible.

Ensure that, when you are not using your KIDS, the start button (1) is always in off mode (out) and the battery is removed from the vehicle.

To prevent the theft of the vehicle, never leave it unattended and secure the vehicle against unauthorized access.

12. CONNECTION TO THE VEHICLE USING THE BLUETOOTH APP

Your KIDS motorcycle has a Bluetooth device that allows you to configure the motorcycle's behavior from your smartphone. It also allows the responsible person of the rider to switch the motorcycle off/on remotely, by accessing the parental control section.

This application, called TORROT KIDS, can be downloaded from Google Play or AppStore.

A label is provided along with the motorcycle's keys with a DEVICE ID and a PIN code to link the motorcycle connectivity device to the mobile using a Bluetooth connection.

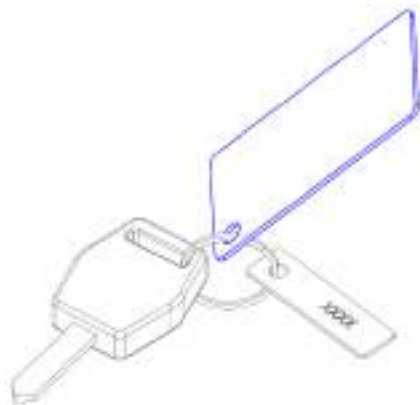

12.1. How to begin

1. The motorcycle must be switched on to connect it with the smartphone application.
2. Activate the Bluetooth and your smartphone's location.
3. Next, open the mobile application. If the mobile has never been paired previously with the motorcycle's Bluetooth device, the device scanning section will automatically open. Press "START SCAN" (1) to search for the name of the motorcycle's Bluetooth device (DEVICE ID).

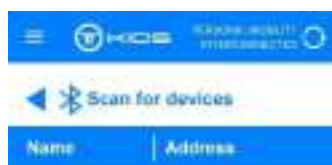

- Once found, select the device which you wish to pair with (2), and enter the device's PIN code (3).

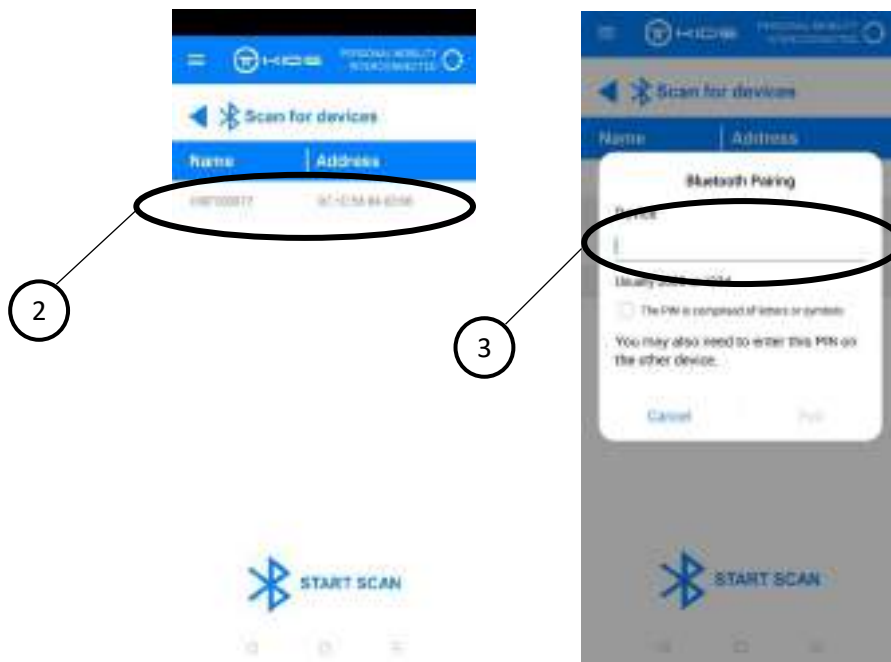

- If the mobile has already been paired previously with the Bluetooth device, this step will not be required given that the pairing will be done automatically, and you could act directly in the main menu. Once the smartphone has been paired with the motorcycle's Bluetooth device, the message "Device Connected!" (4) will appear at the bottom of the main menu.



- If, after a while, this message has not appeared, you must carry out the pairing on the "Scan for devices" menu.

- Once the mobile has been paired with the vehicle's Bluetooth device, the main menu of the TORROT KIDS application will appear. On this menu you can select what you want to do: whether to activate the Parental Control, configure the motorcycle's behavior, or scan the devices again.



12.2. Configuration menu

To be able to access to the 'Configuration' menu (5) and adjust the vehicle's performance, it is essential that the motor is stopped (not accelerating), keeping the motorcycle switched on.



After accepting, a screen will appear on which you can customize the four driving behavior parameters by sliding the following selectors:



- *Max Power: this parameter can be used to customize the motorcycle's maximum power: 20% is the minimum adjustable power. 100% is the maximum adjustable power.*
- *Max Speed: this parameter can be used to customize the motorcycle's maximum speed: 30% is the minimum adjustable speed. 100% is the maximum adjustable speed.*
- *Throttle Response: this parameter can be used to customize the speed of the throttle response: 5% represents the quickest adjustable throttle response. 25% represents the slowest adjustable throttle response.*
- *Regeneration: this parameter can be used to customize the vehicle's regenerative braking level (motor retention) upon releasing the throttle: 0% represents the minimum regenerative. 20% represents the maximum adjustable regenerative.*

Press "Confirm Parameters" (6) to upload the settings to the motorcycle.

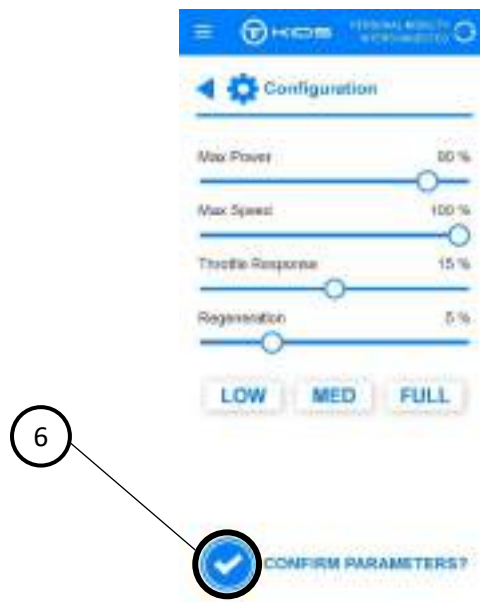

Once the new settings have been uploaded, the settings window will automatically open again. Check the values to ensure the settings have been saved correctly. If they are not the desired values, send the settings again.

12.3. Parental control menu

Parental control has two functionalities, on the one hand, it allows you to stop the motorcycle remotely and, on the other hand it stops the motorcycle if it goes beyond the range of the Bluetooth.

Press the "Parental Control" menu (7) to access to this functionality.



To activate parental control, you have to select the button that enables it (8).



Once activated, it shows the icon that the person responsible for the rider has to press to stop the vehicle remotely. When this icon is blue (9), the vehicle can accelerate, while when it is grey (10), the vehicle cannot accelerate.

If the vehicle loses its connection with the smartphone while parental control is enabled, the vehicle's power supply will automatically be cut off for the rider's safety. When the smartphone is again within the Bluetooth device's range, the connection will be restored automatically, and the rider will be able to continue riding the vehicle.



In the event of any connection errors with the vehicle, try another smartphone, since there may be incompatibilities between the application and some versions of certain operating systems.

13. FAULT DIAGNOSIS

Below is a list to diagnose faults. This is not an exhaustive list to diagnose faults, only some of the most common.

Below are the steps to follow if the vehicle is not working.

1. Ensure that the battery is fully charged.
2. Check that the battery's charge (1) and/or discharge (2) connector are not damaged.

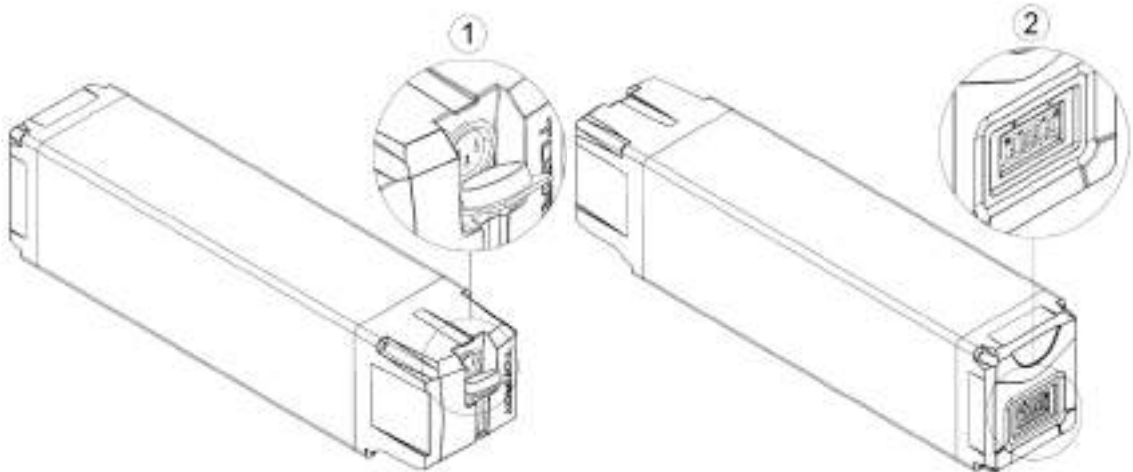

3. Check that the battery is properly connected in the vehicle.
4. Check that the key switch is in the on position.
5. Check that the man overboard is properly connected.
6. Check that the start button located on the throttle is in the on position.

If the vehicle is still not working, contact your nearest official TORROT dealer.



14. FINAL REFLECTIONS

Take the necessary time to inspect the motorcycle, perform periodic maintenance and check all the functions before setting off. Some parts of this manual give data and actions to take at an official TORROT dealer. Therefore, and to increase the motorcycle's lifetime, the periodic inspections of the motorcycle must only be carried out by specialists in the network of official TORROT dealers.

If you detect a technical problem or you have any questions or queries about our products, please contact your nearest official TORROT dealer at www.torrot.com.

You can also write to us at info@torrot.com, giving the frame number, the problem you have detected and your contact details.



If you perform poor maintenance on the motorcycle and ignore problems, no matter how small they are, you may cause serious physical harm or death.

14.1. FAQs

14.1.1. Does the motorcycle have a speed limiting device for new riders?

Yes, this motorcycle is equipped with a speed-limiting device to limit the vehicle's maximum speed. The *speed limiting device* section describes how to access to it to de-restrict/limit the motorcycle.

It is recommended to limit the speed of the motorcycle until the rider's handling of the motorcycle is excellent. The speed limiting setting must thereafter be in accordance with the rider's ability.

14.1.2. Is there a minimum age for using the KIDS?

KIDS are suitable for children aged between 6 and 11 years, although it will depend on the rider's size. Remember that it must always be used under adult supervision.

Moreover, before allowing any rider to ride the vehicle, the parents or legal guardians must assess whether they are ready to ride it. The training required to ride varies from one person to another and age and size are not the only factors (for example, physical skill, mental and emotional maturity, etc.).

14.1.3. Can you ride it on the road?

No. This motorcycle is not suitable for riding on public roads; it can only be used in enclosed areas.

14.1.4. Do I need any kind of third-party civil liability insurance?

No, insurance is not mandatory.

14.1.5. Is it waterproof?

Both the motor and the controller and electrical connections are properly protected for normal use in light to moderate rain. It is absolutely not suited for immersion or pressure cleaning.

14.1.6. Can the charger be left continuously connected to the battery?

Yes, the charger has a voltage detection system that cuts off the power supply as soon as the battery is fully charged. However, it is recommended to disconnect the charger from both the mains and from the battery once the charging has finished.

If you want to store the battery, follow the instructions in the section *Storage of the vehicle*.

14.1.7. Why is the autonomy reduced when it is very cold?

Under 0°C, the battery's performance gets worse, due to the chemical composition of this type of battery. This factor is not a problem, nor does it damage the battery, it only momentarily reduces the battery's capacity, reducing the motorcycle's range.

However, the battery must not be used under -15°C, since temperatures below this value will damage it.

14.1.8. Does it have regenerative braking?

Yes, it has regenerative braking. It occurs only upon releasing the throttle, and its effect (motor retention) can be adjusted through the smartphone application.



+34 972 406 115

info@torrot.com

C/ Unicef, 17 Pol. In. Torremirona. 17190 Salt (Girona) Spain

www.torrot.com

<https://www.motomanuals.net/>