

**Vespa®**

---

**WORKSHOP MANUAL**

---

**633416**

---



**Vespa LX 50**

---



# WORKSHOP MANUAL

## Vespa LX 50

The descriptions and illustrations given in this publication are not binding. While the basic specifications as described and illustrated in this booklet remain unchanged, PIAGGIO-GILERA reserves the right, at any time and without being required to update this publication beforehand, to make any changes to components, parts or accessories, which it considers necessary to improve the product or which are required for manufacturing or construction reasons.

Not all versions/models shown in this publication are available in all countries. The availability of single models should be checked at the official Piaggio sales network.

"© Copyright 2008 - PIAGGIO & C. S.p.A. Pontedera. All rights reserved. Reproduction of this publication in whole or in part is prohibited."

PIAGGIO & C. S.p.A. - After-Sales

V.le Rinaldo Piaggio, 23 - 56025 PONTEDERA (Pi)

---

---

# WORKSHOP MANUAL

## Vespa LX 50

This workshop manual has been drawn up by Piaggio & C. Spa to be used by the workshops of Piaggio-Gilera dealers. This manual is addressed to Piaggio service mechanics who are supposed to have a basic knowledge of mechanics principles and of vehicle fixing techniques and procedures. Any important changes made to the vehicles or to specific fixing operations will be promptly reported by updates to this manual. Nevertheless, no fixing work can be satisfactory if the necessary equipment and tools are unavailable. It is therefore advisable to read the sections of this manual relating to specific tools, along with the specific tool catalogue.

**N.B.** Provides key information to make the procedure easier to understand and carry out.

**CAUTION** Refers to specific procedures to carry out for preventing damages to the vehicle.

**WARNING** Refers to specific procedures to carry out to prevent injuries to the repairer.



**Personal safety** Failure to completely observe these instructions will result in serious risk of personal injury.



**Safeguarding the environment** Sections marked with this symbol indicate the correct use of the vehicle to prevent damaging the environment.



**Vehicle intactness** The incomplete or non-observance of these regulations leads to the risk of serious damage to the vehicle and sometimes even the invalidity of the guarantee.

---



## INDEX OF TOPICS

CHARACTERISTICS

CHAR

TOOLING

TOOL

MAINTENANCE

MAIN

TROUBLESHOOTING

TROUBL

ELECTRICAL SYSTEM

ELE SYS

ENGINE FROM VEHICLE

ENG VE

ENGINE

ENG

SUSPENSIONS

SUSP

BRAKING SYSTEM

BRAK SYS

CHASSIS

CHAS

PRE-DELIVERY

PRE DE

TIME

TIME

## INDEX OF TOPICS

CHARACTERISTICS

CHAR

---

## **Rules**

This section describes general safety rules for any maintenance operations performed on the vehicle.

---

### **Safety rules**

- If work can only be done on the vehicle with the engine running, make sure that the premises are well-ventilated, using special extractors if necessary; never let the engine run in an enclosed area. Exhaust fumes are toxic.
  - The battery electrolyte contains sulphuric acid. Protect your eyes, clothes and skin. Sulphuric acid is highly corrosive; in the event of contact with your eyes or skin, rinse thoroughly with abundant water and seek immediate medical attention.
  - The battery produces hydrogen, a gas that can be highly explosive. Do not smoke and avoid sparks or flames near the battery, especially when charging it.
  - Fuel is highly flammable and it can be explosive given some conditions. Do not smoke in the working area, and avoid naked flames or sparks.
  - Clean the brake pads in a well-ventilated area, directing the jet of compressed air in such a way that you do not breathe in the dust produced by the wear of the friction material. Even though the latter contains no asbestos, inhaling dust is harmful.
- 

### **Maintenance rules**

- Use original PIAGGIO spare parts and lubricants recommended by the Manufacturer. Non-original or non-conforming spare parts may damage the vehicle.
  - Use only the appropriate tools designed for this vehicle.
  - Always use new gaskets, sealing rings and split pins upon refitting.
  - After removal, clean the components using non-flammable or low flash-point solvents. Lubricate all the work surfaces, except tapered couplings, before refitting these parts.
  - After refitting, make sure that all the components have been installed correctly and work properly.
  - For removal, overhaul and refit operations use only tools with metric measures. Metric bolts, nuts and screws are not interchangeable with coupling members with English measurement. Using unsuitable coupling members and tools may damage the scooter.
  - When carrying out maintenance operations on the vehicle that involve the electrical system, make sure the electric connections have been made properly, particularly the ground and battery connections.
-

## Vehicle identification

### VEHICLE IDENTIFICATION

Specification	Desc./Quantity
Chassis prefix	ZAPC38101 ÷ 1001
Engine prefix	C381M ÷ 1001



## Dimensions and mass

### WEIGHT AND DIMENSIONS

Specification	Desc./Quantity
Dry weight	96±4 Kg
Maximum height	1140 mm
Wheelbase	1290 mm
Length	1755 mm
Width	740 mm



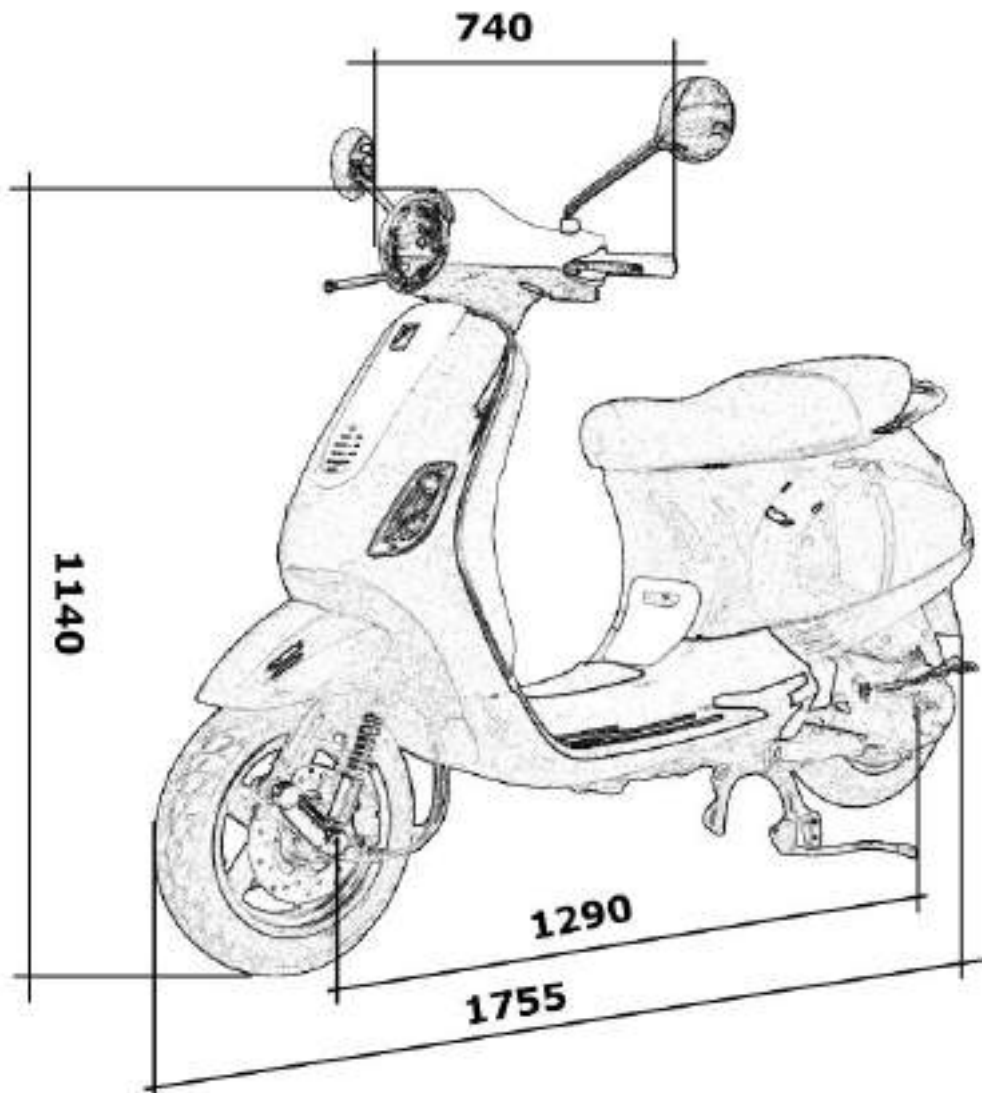

**Engine**

**ENGINE**

Specification	Desc./Quantity
Engine type	Two-stroke, single cylinder Piaggio Hi-PER2
Bore x stroke	40 X 39.3 mm
Cubic capacity	49.40 cc
Compression ratio	10,3 :1
Carburettor	DELL'ORTO PHVA 17.5
CO adjustment	3.5% ± 0.5
Engine idle speed	1800 to 2000 r.p.m.
Air filter	Sponge, soaked in a mixture (50% SELENIA Air Filter Oil and 50% unleaded petrol).
Starting system	electric starter/kick starter
Lubrication	With blend and variable oil variable according to the engine revolutions and the throttle valve opening by means of a pump controlled by the driving shaft with toothed belt.

Specification	Desc./Quantity
Fuel supply	Gravity feed, with unleaded petrol (with a minimum octane rating of 95) with carburettor.
Cooling system	forced coolant circulation system

## Transmission

### TRANSMISSION

Specification	Desc./Quantity
Transmission	With automatic expandable pulley variator, torque server, V-belt, automatic clutch, gear reduction unit.

## Capacities

### CAPACITY

Specification	Desc./Quantity
Rear hub oil	Quantity: approx. 85 cc
oil mixer tank	Plastic, capacity ~ 1.2 l
Fuel tank capacity	~ 8.5 l (2 l of which is reserve)

## Electrical system

### ELECTRICAL SYSTEM

Specification	Desc./Quantity
Type of ignition	Capacitive discharge type electronic ignition, with incorporated high voltage coil
Ignition advance (before TDC)	Fixed $17^{\circ} \pm 1$
Recommended spark plug	CHAMPION RN2C
Battery	12V-4Ah
Main fuse	7.5 A
Generator	In alternate current with three output sections

## Frame and suspensions

### CHASSIS AND SUSPENSIONS

Specification	Desc./Quantity
Type	Unitised body made of stamped plate
Front suspension	Single arm suspension with swinging arm articulated to the steering tube. Hydraulic double-acting shock absorber and coaxial spring
Front suspension stroke	70 mm
Trail (suspension rebounded/compressed)	71/68 mm
Rear suspension	Single hydraulic double-acting shock absorber, helical coaxial spring. Chassis to engine support with swinging arm.
Rear suspension travel:	83.5 mm

## Brakes

### BRAKES

Specification	Desc./Quantity
Front brake	Disc brake ( $\varnothing$ 200 mm) with hydraulic control (lever on the far right of the handlebar) and fixed calliper.
Rear brake	$\varnothing$ 110 mm drum brake

## Wheels and tyres

### WHEELS AND TYRES

Specification	Desc./Quantity
Front tyre size	110/70"-11"
Rear tyre size	120/70-10"
Front tyre pressure	1.6 bar
Rear tyre pressure:	2 bar
Light alloy rims (Front rim)	2.50" x 11"
Light alloy rims (rear rim)	3.00 x 10"

**N.B.**

**CHECK AND ADJUST TYRE PRESSURE WITH TYRES AT AMBIENT TEMPERATURE. ADJUST PRESSURE ACCORDING TO THE WEIGHT OF RIDER AND ACCESSORIES.**

## Secondary air

Follow these steps to clean the sponge filters of the secondary air system:

- 1) Remove the snap-on plastic cover (1) on the transmission cover using a small screwdriver as a lever on the retaining tongues in order to insert one of the three slots found on that cap.
- 2) Wash the polyurethane sponge with water and soap, dry all components with compressed air and refit to place. Refit the intake cap respecting the angle reference.
- 3) Undo the two fixing screws (2) on the aluminium cover of the secondary air housing in order to reach the polyurethane sponge inside that housing; clean as indicated in point 2) and refit all elements after checking the steel tab is not deformed and/or does not guarantee correct tightness at its fitting; replace if necessary.

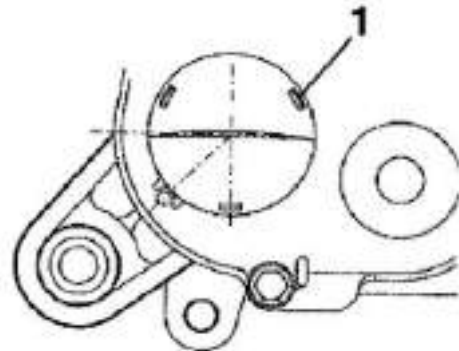

**N.B.**

**UPON REFITTING, MAKE SURE TO CORRECTLY FIT THE TAB IN ITS FITTING ON THE TWO PLASTIC AND ALUMINIUM COVERS.**

#### CAUTION

**WHILE CARRYING OUT OPERATION 3), ALWAYS CHECK THE TWO RUBBER COUPLINGS (3) ON ONE END OF THE SECONDARY AIR PIPE FOR CORRECT TIGHTNESS AND CONTINUITY; IF NECESSARY, REPLACE THEM AND USE NEW CLAMPS TO FIX THEM.**

## Carburettor

### 50cc Version

#### Dell'Orto

#### DELLORTO CARBURETTOR

Specification	Desc./Quantity
Type	PHVA 17.5 RD
Diffuser diameter	Ø 17.5
Regulation reference number	8423
Maximum nozzle:	53
Maximum air nozzle (on the body):	Ø 1.5
Tapered pin stamped code:	A22
Pin position (notches from above):	1
Diffuser:	209 HA
Minimum nozzle:	32
Minimum air nozzle (on the body):	Free
Initial minimum mix screw opening:	1 1/2
Starter jet	50
Starter air nozzle (on the body):	Ø 1.5
Stroke of starter pin:	11 mm
Gasoline inlet hole	Ø 1.5

## Tightening Torques

#### FRONT BRAKE

Name	Torque in Nm
Brake fluid pump-hose fitting	8 ÷ 12
Brake fluid pipe-calliper fitting	20 ÷ 25
Screw tightening calliper to support	20 ÷ 25
Brake disc screw	5 ÷ 6.5
Oil bleed valve (on the calliper)	10 ÷ 12
Handlebar pump	7 ÷ 10

#### FRONT SUSPENSION

Name	Torque in Nm
Shock absorber upper nut	20 ÷ 30
Front wheel axle nut	75 ÷ 90
Shock absorber upper bracket bolts	20 ÷ 25
Wheel rim screws	20 ÷ 25
Shock absorber lower bolts (°)	20 ÷ 27

#### STEERING ASSEMBLY

Name	Torque in Nm
Upper steering ring nut	35 ÷ 40
Steering lower ring nut	8 ÷ 10
Handlebar fixing screw	50 ÷ 55

#### ENGINE ASSEMBLY

Name	Torque in Nm
Clutch bell nut (**)	40 ÷ 44
Clutch lock ring nut	55 ÷ 60
Nut locking driving pulley on crankshaft (**)	40 ÷ 44 Nm
Start-up lever screw	12 ÷ 13
Flywheel nut (**)	40 ÷ 44

Name	Torque in Nm
Flywheel fan screws	3 ÷ 4
Half-crank case joint bolts	12 ÷ 13
Bolts holding exhaust pipe to the crankcase	22 ÷ 24
Screws holding the filter box to the crank case	4 ÷ 5
Head nuts	10 ÷ 11
Starter screws	12 ÷ 13
Ignition spark plug	25 ÷ 30
Hub oil drainage cap	3 ÷ 5
Oil hub level dipstick	Manual
Rear hub cap screws	12 ÷ 13
Transmission cover screws	12 ÷ 13
Inlet manifold screws	8 ÷ 9
Flywheel hood fixing screws	1 ÷ 2
Cylinder hood fixing screws	3.5 ÷ 5
Stator clamping screws	3 ÷ 4
Pick-Up clamping screw	4 ÷ 5
Mixer clamping screws	3 ÷ 4
Screw fixing brake lever to the journal on the engine	12 ÷ 13

### FRAME ASSEMBLY

Name	Torque in Nm
Swinging arm - engine pin*	33 ÷ 41
Swinging arm pin - frame	44 ÷ 52
Shock absorber - chassis nut (*)	20 to 25 Nm
Swinging arm - frame plate	33 ÷ 41
shock absorber - engine pin (*)	33 to 41 N.m
Rear wheel nut	137 ÷ 152
Side stand fixing screw	12 ÷ 20
Side stand bracket fixing screw	15 ÷ 20

## Overhaul data

## Assembly clearances

### Cylinder - piston assy.

#### COUPLING BETWEEN PISTON AND CYLINDER

Name	Initials	Cylinder	Piston	Play on fitting
Standard coupling	M	40.005 - 40.012	39.943 - 39.95	0.055 - 0.069
Standard coupling	N	40.012 - 40.019	39.95 - 39.957	0.055 - 0.069
Standard coupling	O	40.019 - 40.026	39.957 - 39.964	0.055 - 0.069
Standard coupling	P	40.026 - 40.033	39.964 - 39.971	0.055 - 0.069
coupling 1st oversize	M1	40.205 - 40.212	40.143 - 40.15	0.055 - 0.069
coupling 1st oversize	N1	40.212 - 40.219	40.15 - 40.157	0.055 - 0.069
coupling 1st oversize	O1	40.219 - 40.226	40.157 - 40.164	0.055 - 0.069
coupling 1st oversize	P1	40.226 - 40.233	40.164 - 40.171	0.055 - 0.069
Coupling 2nd oversize	M2	40.405 - 40.412	40.343 - 40.35	0.055 - 0.069
Coupling 2nd oversize	N2	40.412 - 40.419	40.35 - 40.357	0.055 - 0.069
Coupling 2nd oversize	O2	40.419 - 40.426	40.357 - 40.364	0.055 - 0.069
Coupling 2nd oversize	P2	40.426 - 40.433	40.364 - 40.371	0.055 - 0.069

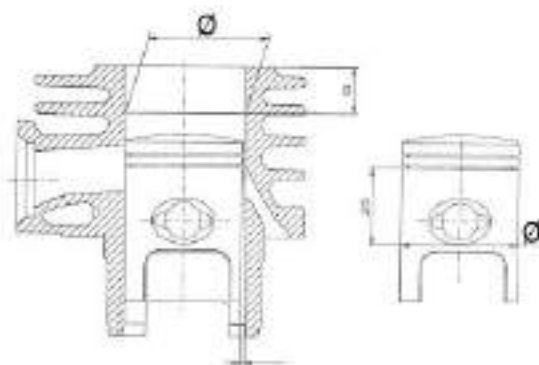

## Piston rings

### SEALING RING

Name	Description	Dimensions	Initials	Quantity
Compression ring		40	A	0.10 to 0.25
Compression ring 1st oversize		40.2	A	0.10 to 0.25
Compression ring 2nd Oversize		40.4	A	0.10 to 0.25

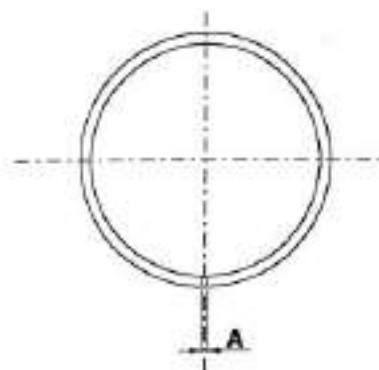

## Crankcase - crankshaft - connecting rod

### AXIAL CLEARANCE BETWEEN CRANKCASE, CRANKSHAFT AND CONNECTING ROD

Name	Description	Dimensions	Initials	Quantity
Connecting rod		11.750-0.05	A	clearance E = 0.25 to 0.50
shoulder washer		0.5 ± 0.03	G	clearance E = 0.25 to 0.50 - clearance F = 0.20 to 0.75
Half-shaft, transmission side		13.75+0.040	C	clearance E = 0.25 to 0.50 - clearance F = 0.20 to 0.75
Flywheel-side half-shaft		13.75+0.040	D	clearance E = 0.25 to 0.50 - clearance F = 0.20 to 0.75
Lining between the shoulders		40.64	H	clearance E = 0.25 to 0.50 - clearance F = 0.20 to 0.75
Cage		11.800-0.35	B	clearance F = 0.20 to 0.75

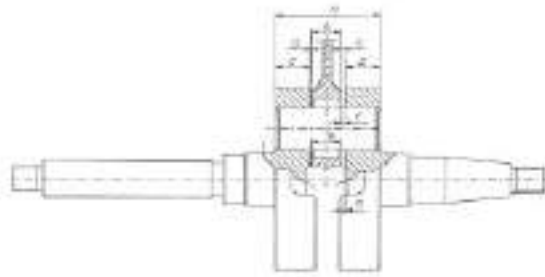

## Slot packing system

This type of engines foresees the use of one size of basic gaskets.

## Products

### RECOMMENDED PRODUCTS TABLE

Product	Description	Specifications
AGIP ROTRA 80W-90	Rear hub oil	SAE 80W/90 Oil that exceeds the requirements of API GL3 specifications
AGIP CITY HI TEC 4T	Oil to lubricate flexible transmissions (brake, throttle control and mixer, odometer)	Oil for 2-stroke engines: SAE 5W-40, API SL, ACEA A3, JASO MA
AGIP FILTER OIL	Oil for air filter sponge	Mineral oil with specific additives for increased adhesiveness
AGIP CITY TEC 2T	Mixer oil	synthetic oil for 2-stroke engines: JASO FC, ISO-L-EGD
AGIP BRAKE 4	Brake fluid	FMVSS DOT 4 Synthetic fluid
MONTBLANC MOLYBDENUM GREASE	Grease for driven pulley shaft adjusting ring and movable driven pulley housing	Grease with Molybdenum disulphide
AGIP GREASE PV2	Grease for the steering bearings, pin seats and swinging arm	White anhydrous-calcium based grease to protect roller bearings; temperature range between -20 C and +120 C; NLGI 2; ISO-L-XBCIB2.
AGIP GREASE SM 2	Grease for odometer transmission gear case	Lithium grease with NLGI 2 molybdenum disulphide; ISO-L-XBCHB2, DIN KF2K-20
AGIP GP 330	Grease for brake control levers, throttle, stand	White calcium complex soap-based spray grease with NLGI 2; ISO-L-XBCIB2

## INDEX OF TOPICS

TOOLING

TOOL



**ATTREZZATURA**

Stores code	Description	
001330Y	Tool for fitting steering seats	
001467Y006	Pliers to extract 20 mm bearings	
001467Y009	Driver for OD 42-mm bearings	
001467Y013	Pliers to extract ø 15-mm bearings	
001467Y014	Pliers to extract ø 15-mm bearings	
001467Y017	Bell for bearings, OD 39 mm	
002465Y	Pliers for circlips	

Stores code	Description	
006029Y	Punch for fitting fifth wheel seat on steering tube	
020004Y	Punch for removing fifth wheels from headstock	
020055Y	Wrench for steering tube ring nut	
020150Y	Air heater support	
020151Y	Air heater	
020162Y	Flywheel extractor	
020163Y	Crankcase splitting plate	

Stores code	Description	
020166Y	Pin lock fitting tool	 A photograph showing three components of a pin lock fitting tool: a small black cylindrical cap, a longer black cylindrical pin, and a black-handled screwdriver with a metal shaft.
020261Y	Starter spring fitting	 A photograph of a black metal T-shaped tool with a cylindrical base and a long handle, used for fitting starter springs.
020265Y	Bearing fitting base	 A photograph of a black rectangular metal base with a central opening, used for bearing fitting.
020325Y	Pliers for brake-shoe springs	 A photograph of a pair of silver-colored pliers with curved jaws, designed for working with brake shoe springs.
020329Y	Mity-Vac vacuum-operated pump	 A photograph of a white plastic vacuum-operated pump with various ports and a black hose attached.
020330Y	Stroboscopic light to check timing	 A photograph of a white handheld stroboscopic light with a black power cord and a black strap.

Stores code	Description
-------------	-------------

020331Y

Digital multimeter



020332Y

Digital rpm indicator



020333Y

Single battery charger

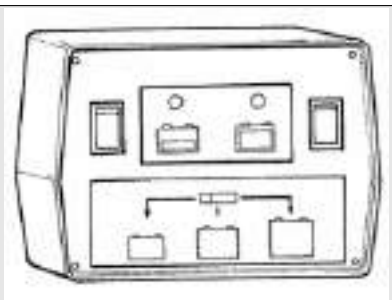

020334Y

Multiple battery charger



Stores code	Description	
020335Y	Magnetic support for dial gauge	
020350Y	Electrical system check instrument	
020359Y	42x47-mm Adaptor	
020376Y	Adaptor handle	
020412Y	15-mm guide	

Stores code	Description
-------------	-------------

020456Y

Ø 24 mm adaptor



020565Y

Flywheel lock calliper spanner



494929Y

Exhaust fumes analyser



001467Y029

Bell for bearings, O.D. 38 mm



020037Y

Punch



020036Y

Punch



Stores code	Description
-------------	-------------

020021Y

Front suspension service tool

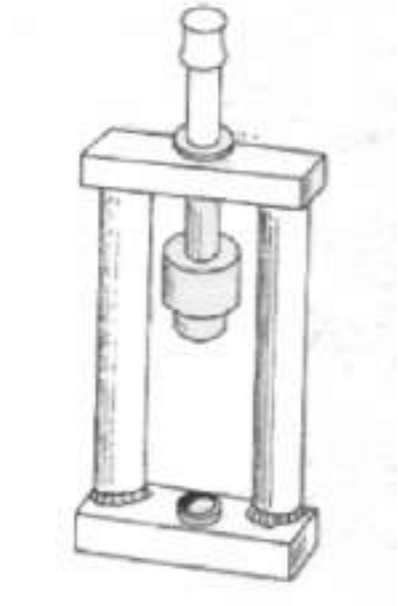

020038Y

Punch



020074Y

Support base for checking crankshaft alignment



004499Y001





Bearing extractor bell





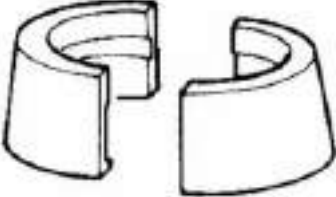

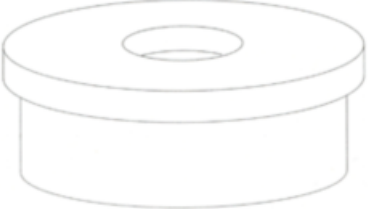
004499Y006



Bearing extractor ring



Stores code	Description	
004499Y002	Bearing extractor screw	
004499Y007	Half rings	
020171Y	Punch for driven pulley roller bearing	
020340Y	Flywheel and transmission oil seals fitting punch	
020360Y	52x55-mm Adaptor	
020358Y	37x40-mm Adaptor	
020362Y	12 mm guide	



Stores code	Description	
020363Y	20-mm guide	
020365Y	22 mm guide	
020439Y	17-mm guide	
020441Y	26 x 28 mm adaptor	
020452Y	Tube for removing and refitting the driven pulley shaft	

Stores code	Description	
020451Y	Starting ring gear lock	
020444Y	Tool for fitting/ removing the driven pulley clutch	

## INDEX OF TOPICS

**MAINTENANCE**

**MAIN**

## Maintenance chart

### EVERY 2 YEARS

#### Action

Brake fluid - change

### AFTER 1000 KM

50'

#### Action

Hub oil - change

Oil mixer/throttle linkage - adjustment

Odometer gear - greasing

Steering - adjustment

Brake control levers - greasing

Brake fluid level - check

Safety locks - check

Electrical system and battery - check

Tyre pressure and wear - check

Vehicle and brake test - road test

### AFTER 5000 KM, 25000 KM, 35000 KM AND 55000 KM

40'

#### Action

Hub oil level - check

Spark plug/electrode gap - replacement

Air filter - clean

Oil mixer/throttle linkage - adjustment

Brake control levers - greasing

Brake pads - check condition and wear

Brake fluid level - check

Electrical system and battery - check

Tyre pressure and wear - check

Vehicle and brake test - road test

### AFTER 10000 KM, 50000 KM

95'

#### Action

Hub oil - change

Spark plug/electrode gap - replacement

Air filter - clean

Idling speed (\*) - adjustment

Oil mixer/throttle linkage - adjustment

Variable speed rollers - replacement

Odometer gear - greasing

Driving belt - checking

Steering - adjustment

Brake control levers - greasing

Brake pads - check condition and wear

Brake fluid level - check

Transmission elements - lubrication

Safety locks - check

Suspensions - check

Electrical system and battery - check

Headlight - adjustment

Tyre pressure and wear - check

Vehicle and brake test - road test

(\*) See regulations in the «Adjusting the idle speed» section

### AFTER 15000 KM AND 45000 KM

65'

**Action**

Hub oil level - check
Spark plug/electrode gap - replacement
Air filter - cleaning
Oil mixer/throttle linkage - adjustment
Driving belt - replacement
Brake control levers - greasing
Brake pads - check condition and wear
Brake fluid level - check
Electrical system and battery - check
Tyre pressure and wear - check
SAS box (sponge) (**) - cleaning
Vehicle and brake test - road test

(\*\*) See regulations in the «Secondary air system» section

**AFTER 20000 KM AND 40000 KM**

110'

**Action**

Hub oil - change
Spark plug/electrode gap - replacement
Air filter - clean
Idling speed (*) - adjustment
Cylinder cooling system - check/cleaning
Oil mixer/throttle linkage - adjustment
Driving belt - checking
Variable speed rollers - replacement
Mixer belt - replacement
Odometer gear - greasing
Steering - adjustment
Brake control levers - greasing
Brake pads - check condition and wear
Brake fluid level - check
Transmission elements - lubrication
Safety locks - check
Suspensions - check
Electrical system and battery - check
Headlight - adjustment
Tyre pressure and wear - check
Vehicle and brake test - road test

(\*) See section «Adjusting the idle speed»

**AFTER 30000 KM**

130'

**Action**

Hub oil - change
Spark plug/electrode gap - replacement
Air filter - clean
Idling speed (*) - adjustment
Oil mixer/throttle linkage - adjustment
Driving belt - replacement
Variable speed rollers - replacement
Odometer gear - greasing
Steering - adjustment
Brake control levers - greasing
Brake pads - check condition and wear
Flexible brake tubes - replacement
Brake fluid level - check
Transmission elements - lubrication
Safety locks - check
Suspensions - check
Electrical system and battery - check
Headlight - adjustment
Tyre pressure and wear - check
SAS box (sponge) (**) - cleaning
Vehicle and brake test - road test

(\*) See regulations in the «Adjusting the idle speed» section

(\*\*) See regulations in the «Secondary air system» section

### AFTER 60000 KM

150'

#### Action

Hub oil - change
Spark plug/electrode gap - replacement
Air filter - clean
Idling speed (*) - adjustment
Cylinder cooling system - check/cleaning
Oil mixer/throttle linkage - adjustment
Driving belt - replacement
Variable speed rollers - replacement
Mixer belt - replacement
Odometer gear - greasing
Steering - adjustment
Brake control levers - greasing
Brake pads - check condition and wear
Flexible brake tubes - replacement
Brake fluid level - check
Transmission elements - lubrication
Safety locks - check
Suspensions - check
Electrical system and battery - check
Headlight - adjustment
Tyre pressure and wear - check
SAS box (sponge) (**) - cleaning
Vehicle and brake test - road test

(\*) See regulations in the «Adjusting the idle speed» section

(\*\*) See regulations in the «Secondary air system» section

## Carburettor

- Disassemble the carburettor in its parts, wash all of them with solvent, dry all body grooves with compressed air to ensure adequate cleaning.
- Check carefully that the parts are in good condition.
- The **throttle valve** should move freely in the chamber. Replace valve in case of wear due to excessive clearance.
- If there are wear marks in the chamber causing inadequate tightness or a free valve slide (even if it is new), replace the carburettor.
- It is advisable to replace the gaskets at every refit.

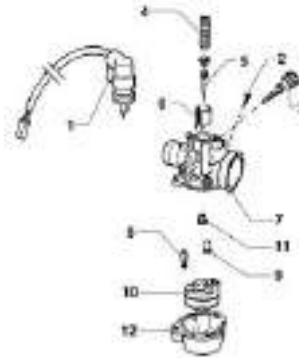

#### WARNING

**PETROL IS HIGHLY EXPLOSIVE ALWAYS REPLACE THE GASKETS TO AVOID PETROL LEAKS**

1. Automatic starter - 2. Idle air set screw - 3. Idle speed set screw - 4. Throttle valve spring - 5. Throttle valve tapered pin - 6. Throttle valve - 7. Carburettor body - 8. Pin - 9. Min. jet - 10. Float - 11. Max. jet - 12. Float chamber

## Checking the spark advance

-Check to be made at over 4000 rpm with stroboscopic gun. The advanced ignition measured must be  $17^\circ$  before the TDC.

- This value is correct when the reference mark on the flywheel hood is aligned with the reference mark on the cooling fan and the phase shifter on the stroboscopic gun is set on  $17^\circ$ .

**N.B.**

**IN CASE OF MALFUNCTION, CARRY OUT THE CHECKS PROVIDED FOR IN THE ELECTRICAL SYSTEM CHAPTER.**

**CAUTION**

**BEFORE CARRYING OUT THE ABOVE CHECKS, CHECK THE CORRECT KEYING OF THE FLYWHEEL ON THE CRANKSHAFT.**

### Specific tooling

**020330Y Stroboscopic light to check timing**



## Spark plug

Place the vehicle on its central stand

- Remove the central cover, indicated in the figure, by undoing the 2 fixing screws;
- Disconnect spark plug HV wire hood;
- Undo the spark plug using the socket wrench;
- Examine the condition of the spark plug, check that the insulating material is whole and measure the distance between the electrodes using a thickness gauge.
- Adjust the distance if necessary by bending the side electrode very carefully.

In the case of defects, replace the spark plug with one of the specified type;

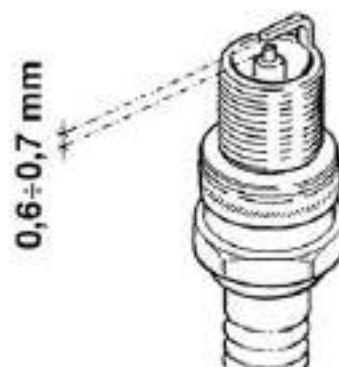

- Engage the spark plug with the due inclination and screw it right down by hand, then do it up with the wrench at the prescribed torque;
- Put the hood on the sparking plug as far as it will go;
- Refit the central flap.

**CAUTION**

THE SPARK PLUG MUST BE REMOVED WHEN THE MOTOR IS COLD. THE SPARK PLUG MUST BE REPLACED EVERY 5000 KM. USE OF STARTERS NOT CONFORMING OR SPARK PLUGS NOT THOSE DESCRIBED CAN SERIOUSLY DAMAGE THE ENGINE.

**Characteristic****Recommended spark plug**

CHAMPION RN2C

**Electric characteristic****Electrode gap**

0.6 to 0.7 mm.

**Locking torques (N\*m)**

Spark plug 25 - 30 Nm

---

**Hub oil**

---

**Check**

Do the following to check the correct level:

- 1) Stand the vehicle on the centre-stand on flat ground;
- 2) Remove the dipstick «A», and dry it with a clean cloth. Reinsert it, screwing it in all the way;
- 3) Remove the stick and check that the oil level is slightly over the second notch starting from the lower end;
- 4) Screw the dipstick back in, checking that it is locked in place.

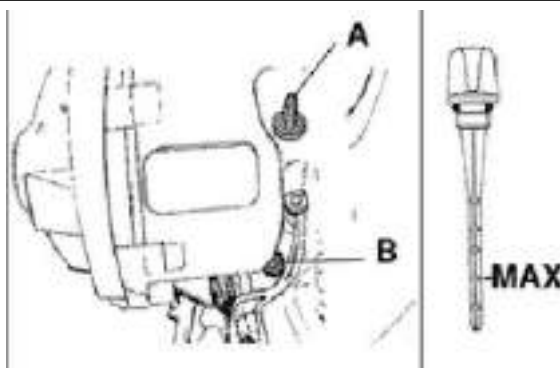
**Recommended products****AGIP ROTRA 80W-90 Rear hub oil**

SAE 80W/90 Oil that exceeds the requirements of API GL3 specifications



## Replacement

- Remove the oil cap «A».
- Unscrew the oil drainage cap "B" and drain out all the oil.
- Screw on the drainage plug and fill up the hub with oil (about 85 cc)

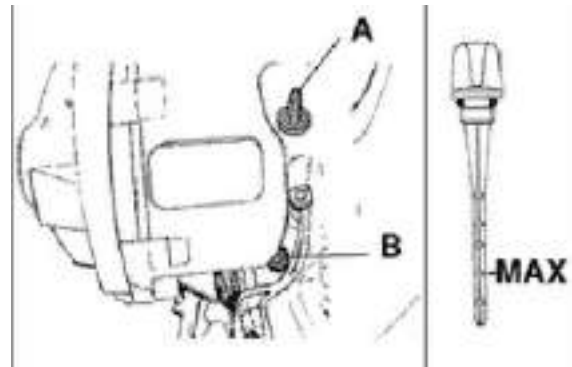

## Air filter

- Remove the cap of the purifier, unscrewing the six clamping screws and removing the filter.

### Cleaning:

- Wash with water and neutral soap.
- Dry with a clean cloth and short blasts of compressed air.
- Saturate with a 50% mixture of gasoline and oil.
- Drip dry the filter and then squeeze it between the hands without wringing.
- Let it dry and refit it again.

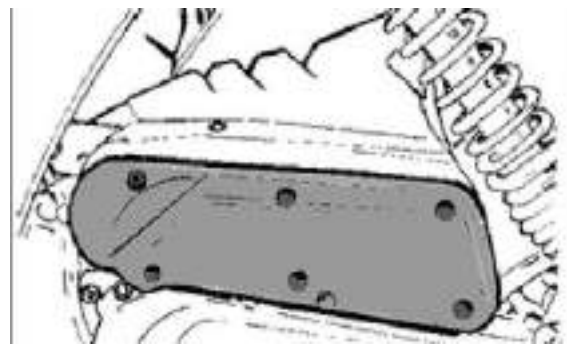

### CAUTION

**NEVER RUN THE ENGINE WITHOUT THE AIR FILTER, THIS WOULD RESULT IN AN EXCESSIVE WEAR OF THE PISTON AND CYLINDER.**

### Recommended products

#### AGIP FILTER OIL Oil for air filter sponge

Mineral oil with specific additives for increased adhesiveness

## Checking the ignition timing

- Adjust the control cables:

Mix cable: see procedure indicated in "Mixer timing".

Throttle cable: adjust the set screw on the carburettor in such a way that the sheath has no backlash.

Splitter control cable: adjust set screw on the throttle control to the handlebar in such a way that there is no backlash on the throttle control.

Adjust all transmissions in such a way that their sheathings show no sign of backlash.

### Mixer Timing

- Using the transmission set screw on the crankcase, with throttle control untwisted, adjust the reference mark on the rotating plate so that it is lined up with the reference mark on the mixer body, as shown in the figure.

While doing this, the engine must be fuelled with a 2 % oil mixture (0.5 litre minimum if the reservoir is empty).

#### CAUTION

IN CASE OF DISMANTLING OR RUNNING OUT OF OIL IN THE RESERVOIR BLEED THE MIXER AS FOLLOWS: REFILL THE OIL RESERVOIR WHEN THE MIXER IS FITTED TO THE VEHICLE AND THE ENGINE IS OFF, UNDO THE MIXER PIPE FROM THE CARBURETTOR AND LOOSEN THE BLEED SCREWS (SEE THE ARROW IN THE FIGURE) UNTIL THE OIL BEGINS TO FLOW OUT. TIGHTEN THE SCREWS, START UP THE ENGINE AND WAIT FOR OIL TO FLOW OUT OF THE TUBE. RECONNECT THE DELIVERY PIPE TO THE CARBURETTOR AND FIX IT IN PLACE WITH THE RELEVANT METAL CLIP.

### Recommended products

#### AGIP CITY TEC 2T Mixer oil

synthetic oil for 2-stroke engines: JASO FC, ISO-L-EGD

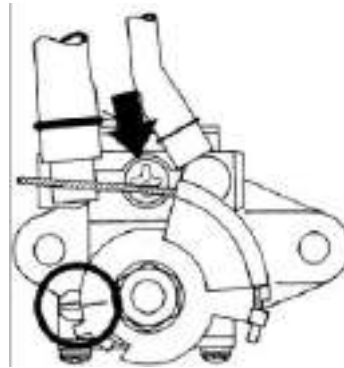

## Braking system

## Level check

Proceed as follows:

- Rest the vehicle on its centre stand with the handlebars perfectly horizontal;
- Check the level of liquid with the related warning light «A».

A certain lowering of the level is caused by wear on the pads.



## Top-up

Proceed as follows:

- Remove the tank cap by loosening the two screws, remove the gasket and top up using only the liquid specified without exceeding the maximum level.

### CAUTION

ONLY USE DOT 4-CLASSIFIED BRAKE FLUID.

### CAUTION



AVOID CONTACT OF THE BRAKE FLUID WITH YOUR EYES, SKIN, AND CLOTHING. IN CASE OF ACCIDENTAL CONTACT, WASH WITH WATER.

### CAUTION

BRAKING CIRCUIT FLUID IS HIGHLY CORROSIVE; MAKE SURE THAT IT DOES NOT COME INTO CONTACT WITH THE PAINTWORK.

### CAUTION

THE BRAKE FLUID IS HYGROSCOPIC, IN OTHER WORDS, IT ABSORBS MOISTURE FROM THE SURROUNDING AIR. IF THE CONTENT OF MOISTURE IN THE BRAKING FLUID EXCEEDS A CERTAIN VALUE, BRAKING WILL BE INEFFICIENT.

NEVER USE BRAKE LIQUID IN OPEN OR PARTIALLY USED CONTAINERS.

UNDER NORMAL CLIMATIC CONDITIONS, THE FLUID MUST BE CHANGED EVERY 20,000 KM OR ANYWAY EVERY TWO YEARS.

### N.B.

SEE THE BRAKING SYSTEM CHAPTER WITH REGARD TO THE CHANGING OF BRAKE FLUID AND THE BLEEDING OF AIR FROM THE CIRCUITS.

## Recommended products

**AGIP BRAKE 4 Brake fluid**

FMVSS DOT 4 Synthetic fluid

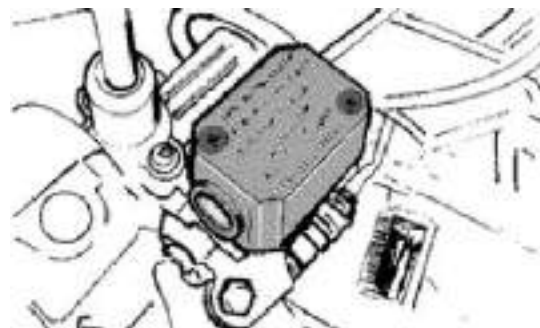

## Headlight adjustment

Proceed as follows:

1. Place the vehicle, in running order and with the tyres inflated to the prescribed pressure, on a flat surface 10-m away from a white screen situated in a shaded area, making sure that the longitudinal axis of the scooter is perpendicular to the screen;
2. Turn on the headlight and check that the borderline of the projected light beam on the screen is not higher than 9/10 or lower than 7/10 of the distance from the ground to the centre of vehicle headlamp;
3. If otherwise, adjust the right headlight with screw «A».

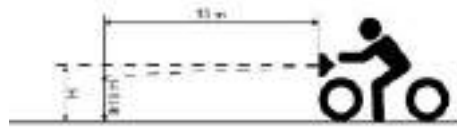

**N.B.**

THE ABOVE PROCEDURE COMPLIES WITH THE EUROPEAN STANDARDS REGARDING MAXIMUM AND MINIMUM HEIGHT OF LIGHT BEAMS. REFER TO THE STATUTORY REGULATIONS IN FORCE IN EVERY COUNTRY WHERE THE VEHICLE IS USED.

## CO check

- Remove the RHS fairing
- Remove the air-box cover and its aluminium manifold, by removing the clamp shown in the figure



Attach the exhaust gas collection tube to the secondary air rubber manifold. Such joint must be sealed in order to guarantee accurate CO readings.



- Start the engine, adjust the idle speed to  $1,700 \pm 100$  rpm and check the CO value is equal  $3.5 \pm 1\%$

- If the parameters found do not agree with the above figures, act upon the idle adjusting screw. Otherwise, check the automatic choke device

### Specific tooling

020320Y Exhaust gases analyser

020332Y Digital rpm indicator

---

## SAS filters inspection and cleaning

Remove the right side fairing by undoing the 2 screws marked «B» indicated in the figure.

Remove the two screws «A» from the aluminium SAS cover. Release the metal tube from the rubber housing on the cover without extracting the tube from the cover/sleeve. Remove the tab and plastic cover, extract the sponge and wash it in water and soap. Dry it with compressed air before refitting it, making sure to correctly fit the tab in the housing on the two plastic and aluminium covers. Every time you disassemble the filter, replace the O-ring seal located in the cover.

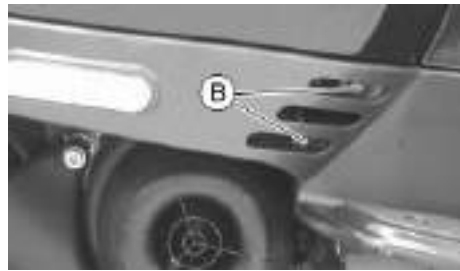

# INDEX OF TOPICS

TROUBLESHOOTING

TROUBL

This section makes it possible to find the solutions to use in troubleshooting.

For each breakdown, a list of the possible causes and respective interventions is given.

## Engine

### Poor performance

#### POOR PERFORMANCE

Possible Cause	Operation
Fuel nozzles or cock clogged or dirty	Dismantle, wash with solvent and dry with compressed air
Excess of encrustations in the combustion chamber	Remove the encrustations
Lack of compression wear of the piston rings or cylinder	Check the worn parts and replace them
Exhaust pipe clogged due to excessive encrustations	Replace the exhaust pipe and check the carburation and mixer timer
Air filter blocked or dirty	Clean according to the procedure
Starter inefficient (stays on)	Check the mechanical sliding, continuity of the circuit, the presence of power and electrical wiring
Clutch slipping	Check the centrifugal brake shoe assembly and /or clutch bell and replace if necessary
Defective mobile pulley sliding	Check the parts, change the faulty parts and lubricate the driven pulley using only Montblanc-Molibdenum Grease (dis. 498345) grease
Driving belt worn	Replace
Carburettor nozzles clogged	Dismantle, wash with solvent and dry with compressed air
Fuel filter on vacuum operated cock blocked	Clean the cock filter
Roller wear; Presence of oil; Dirt	Check the cap with filter is fitted to the transmission cover; clean the speed variator, replace the rollers if worn out

### Rear wheel spins at idle

#### REAR WHEEL

Possible Cause	Operation
Idling rpm too high	Check the idling speed and, if necessary, adjust the C.O.
Clutch fault	Check the spring/friction mass and the clutch bell
Air filter housing not sealed	Correctly refit the filter housing and replace it if it is damaged

### Starting difficulties

#### DIFFICULTY STARTING

Possible Cause	Operation
Carburettor nozzles clogged or dirty	Dismantle, wash with solvent and dry with compressed air
Faulty fuel cock	Check that, at ignition and with throttle untwisted, no petrol flows out the delivery pipe; otherwise, replace the vacuum-operated cock
Starter inefficient	Check: electric wiring, circuit continuity, mechanical sliding and power supply
Defective spark plug or with incorrect electrode gap	Check and if necessary replace the spark plug and the electrode gap
Battery flat	Check the state of the battery. If it shows signs of sulphation replace it and bring the new battery into service charging it for eight hours at a current of 1/10 of the capacity of the battery itself
- Engine flooded.	Start the vehicle keeping the throttle fully open alternately making the engine run for approx. five seconds and stopping for other five seconds. If however it does not start, remove the spark plug, the engine over with the throttle open being careful

Possible Cause	Operation
	to keep the cap in contact with the spark plug and the spark plug grounded but away from its hole. Refit a dry spark plug and start the vehicle.
Altered fuel characteristics	Drain off the fuel no longer up to standard; then, refill
Faulty spark plug	Remove the encrustation, restore the plug gap or replace being sure to use the types of spark plug recommended at all times. Bear in mind that many problems engines have, derive from the use of the wrong spark plug
Intake joint cracked or with a bad seal	Replace intake joint and check for correct sealing on the head
Purifier-carburettor fitting damaged	Replace

## Excessive oil consumption/Exhaust smoke

### EXCESSIVE OIL CONSUMPTION/SMOKEY EXHAUST

Possible Cause	Operation
Excess of encrustations in the combustion chamber	Remove the encrustations

## Engine tends to cut-off at full throttle

### ENGINE STOP FULL THROTTLE

Possible Cause	Operation
Maximum nozzle dirty - lean mixture	Wash the nozzle with solvent and dry with compressed air
Dirty carburettor	Wash the carburettor with solvent and dry with compressed air
Water in the carburettor	Empty the tank through the appropriate bleed nipple.
Air filter dirty	Clean or replace
Defective floating valve	Check the proper sliding of the float and the functioning of the valve
Tank breather hole obstructed	Restore the proper reservoir aeration

## Engine tends to cut-off at idle

### ENGINE STOP IDLING

Possible Cause	Operation
Minimum nozzle dirty	Wash the nozzle with solvent and dry with compressed air
Starter that stays open	Check: electric wiring, circuit continuity, mechanical sliding and power supply
Reed valve does not close	Check / replace the reed pack
Wrong idling adjustment	Correctly adjust the engine idling and check the level of the C.O.
Spark plug defective or faulty	Replace the spark plug with one with the specified degree and check the plug gap

## Excessive exhaust noise

### INCREASED NOISINESS

Possible Cause	Operation
Secondary metal air pipe deteriorated	Check there are no leaks on the hoses on the crankcase and the housing, check that there is a cap with filter and it is correctly fitted to the transmission cover
Good condition of the missing secondary air circuit components	Check the individual components and the piping, check the precision of the fitting. Replace the damaged components



## High fuel consumption

### HIGH FUEL CONSUMPTION

Possible Cause	Operation
Air filter blocked or dirty.	Clean according to the procedure
Starter inefficient	Check: electric wiring, circuit continuity, mechanical sliding and power supply

## SAS malfunctions

### SLACKENING OF THE RUBBER JOINT OF THE SECONDARY AIR PIPE ON THE MUFFLER

Possible Cause	Operation
Secondary air reed blocking	Replace
Secondary air filter clogging	Clean the filter and the housing
Blockage of the secondary air fitting on the muffler	Remove the encrustations from the joint being careful not to let the debris fall into the muffler

## Transmission and brakes

### Clutch grabbing or performing inadequately

#### CLUTCH BRAKES

Possible Cause	Operation
Slippage or irregular functioning	<p>Check that the masses open and return normally</p> <p>Check that there is no grease on the masses</p> <p>Check that the clutch masses' contact surface with the clutch bell is mainly in the middle with characteristics equivalent on the three masses</p> <p>Check that the clutch bell is not scored or worn abnormally</p> <p>Never operate the engine without the clutch bell</p> <p>Check the cap with filter is fitted to the transmission cover</p>

### Insufficient braking

#### BRAKING SYSTEM MALFUNCTION

Possible Cause	Operation
Poor braking	<p>The rear (drum type) brake is adjusted by regulating the special adjustment (on the wheel) bearing in mind that, with the control levers in the rest position, the wheels must turn freely.</p> <p>The braking action should begin when the brake levers are pressed by about a third.</p> <p>Check the brake pad wear.</p> <p>If it is not possible to remove any problems by simply adjusting the transmissions, check the brake pads and front brake disc, the brake shoes and the rear drum. If you encounter excessive wear or scoring, make the necessary replacements.</p>
Air bubbles inside the hydraulic braking system	Carefully bleed the hydraulic braking system, (there must be no flexible movement of the brake lever).
Fluid leakage in hydraulic braking system The brake fluid has lost its properties	Elastic fittings, piston seals or brake pump breakdown, replace Replace the front brake fluid and top up to the correct level in the pump
Defective sliding of the cables in their sheathes	Lubricate or substitute
Brake noise	Check the wear of the brake pads and/or shoes

## Brakes overheating

### BRAKES OVERHEATING

Possible Cause	Operation
Defective piston sliding	Check calliper and replace any damaged part.
Brake disc or drum deformed	Using a dial gauge, check the planarity of the disk with the wheel correctly fitted or the concentricity of the rear drum.

## Electrical system

### Battery

#### BATTERY

Possible Cause	Operation
Battery	The battery is the electrical device in the system that requires the most frequent inspections and thorough maintenance. If the vehicle is not used for some time (1 month or more) the battery needs to be recharged periodically. The battery runs down completely in the course of 5 ÷ 6 months. If the battery is fitted on a motorcycle, be careful not to invert the connections, keeping in mind that the black ground wire is connected to the negative terminal while the red wire is connected to the terminal marked+. Follow the instructions in the ELECTRICAL SYSTEM chapter for the recharging of the batteries.

## Steering and suspensions

### Heavy steering

#### STEERING HARDENING

Possible Cause	Operation
Torque not conforming	Check the tightening of the top and bottom ring nuts. If irregularities continue in turning the steering even after making the above adjustments, check the seats in which the ball bearings rotate: replace if they are recessed.

### Excessive steering play

#### EXCESSIVE STEERING CLEARANCE

Possible Cause	Operation
EXCESSIVE STEERING CLEARANCE	Check the tightening of the top and bottom ring nuts. If irregularities continue in turning the steering even after making the above adjustments, check the seats in which the ball bearings rotate: replace if they are recessed.

### Noisy suspension

#### NOISY SUSPENSION

Possible Cause	Operation
NOISY SUSPENSION	If the front suspension is noisy, check: the efficiency of the front shock absorbers; the condition of the ball bearings and relevant

**Possible Cause****Operation**

lock-nuts, the limit switch rubber buffers and the movement bushings.

---

**Suspension oil leakage****OIL LEAKAGE FROM SUSPENSION****Possible Cause****Operation**

Oil leakage from suspension

Service the pumping members and check the sleeves and sealing rings are in good conditions. Replace the damaged parts

---

## INDEX OF TOPICS

ELECTRICAL SYSTEM

ELE SYS

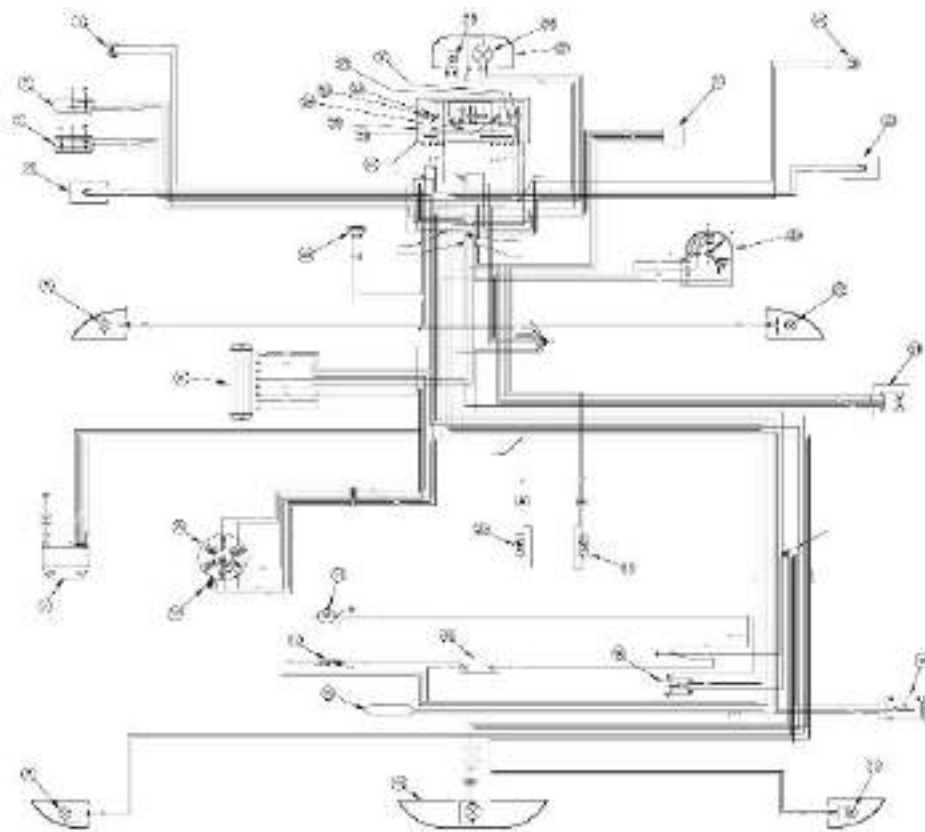

**ELECTRICAL COMPONENTS**

	Specification	Desc./Quantity
1	Rear brake stop button	
2	Light switch	
3	Turn indicator switch	
4	Horn button	
5	Front left turn indicator	
6	Voltage regulator	
7	Electronic ignition device	
8	rear left turn indicator	
9	Flywheel magneto	
10	Pick - up	
11	Starter motor	
12	7.5A	
13	Automatic choke diagnostic light	
14	Rear light assembly	
15	Battery	12V - 4Ah
16	Start-up remote control switch	
17	rear right turn indicator	
18	Fuel level sender	
19	Heater	
20	Automatic starter	
21	Oil level sender	
22	front right turn indicator	
23	Key switch	
24	Starter button	
25	Front brake stop button	
26	Heater control device	
27	Headlight assembly	
28	Headlight bulb	12V-35/35W
29	Front side light bulb	12V - 5W
30	Right turn indicator warning light	
31	Headlamp warning light	
32	Low fuel warning light	

	Specification	Desc./Quantity
33	Left turn indicator warning light	
34	Oil warning light	
35	Dashboard light bulbs	<b>Type:</b> Bayonet <b>Power:</b> 12V 1.2W <b>Quantity:</b> 3
36	High-beam lamp warning light	12V - 1.2W
37	INSTRUMENT PANEL	
38	Horn	

R = Red - B = White - Bl = Blue - N = Black - V = Green - Rs = Pink - Mr = Brown - Gr = Grey - Az = Sky  
Blue G = Yellow Vi = Purple A = Orange

### Conceptual diagrams

### Ignition

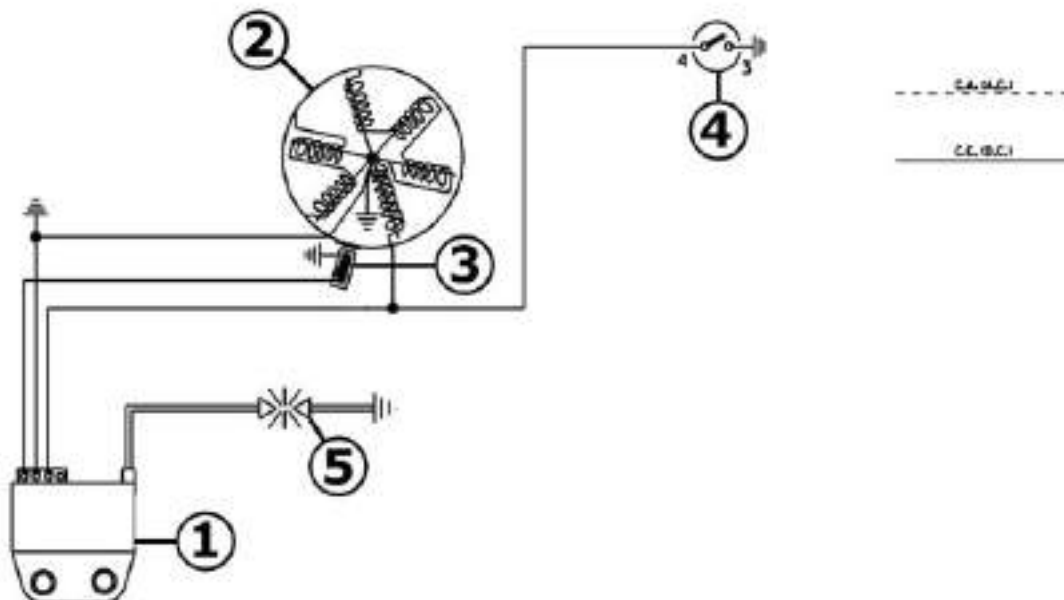

#### IGNITION

	Specification	Desc./Quantity
1	Electronic control unit	
2	Magneto flywheel	
3	Pick - up	
4	Key switch	
5	Spark plug	

Headlights and automatic starter section

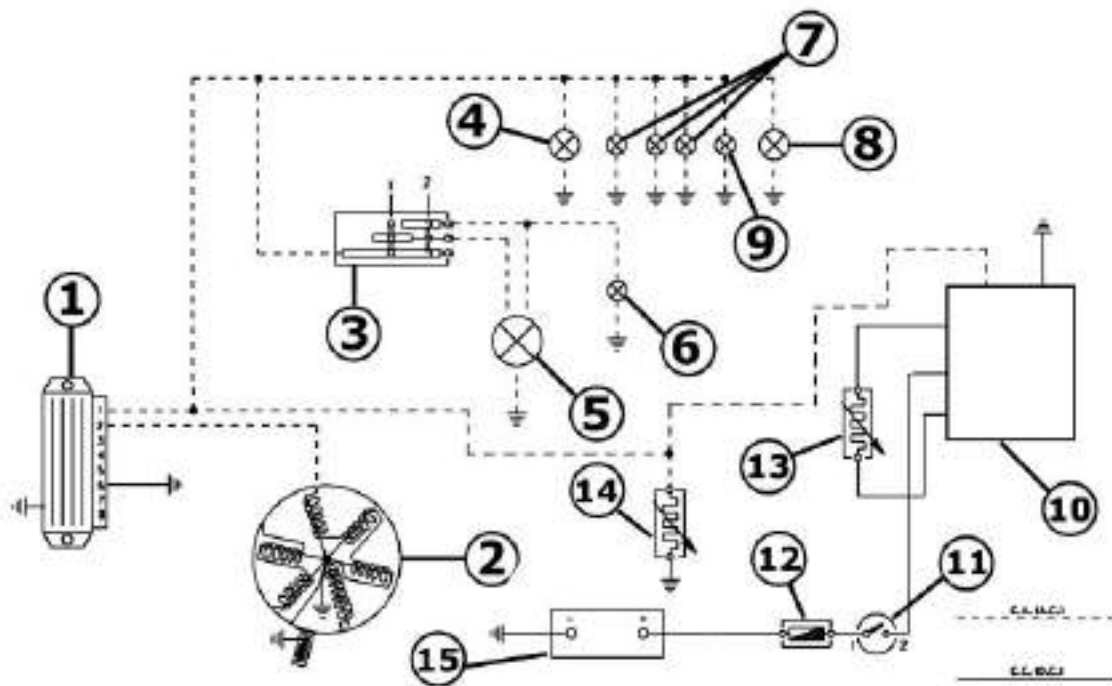

**LIGHTS**

	Specification	Desc./Quantity
1	Voltage regulator	
2	Magneto flywheel	
3	Light switch	
4	Rear light bulb	12V - 5W
5	Headlight bulb	12V-35/35W
6	High-beam warning light	12V - 1.2W
7	N°3 instrument lighting bulbs	12V - 1.2W
8	Taillight bulb	12V - 5W
9	Headlight warning light	12V - 1.2W
10	Heater control device	
11	Key switch contacts	
12	Fuse 7,5A	
13	Carburettor heater	
14	Automatic starter	
15	Battery	12V - 4Ah

**Battery recharge and starting**

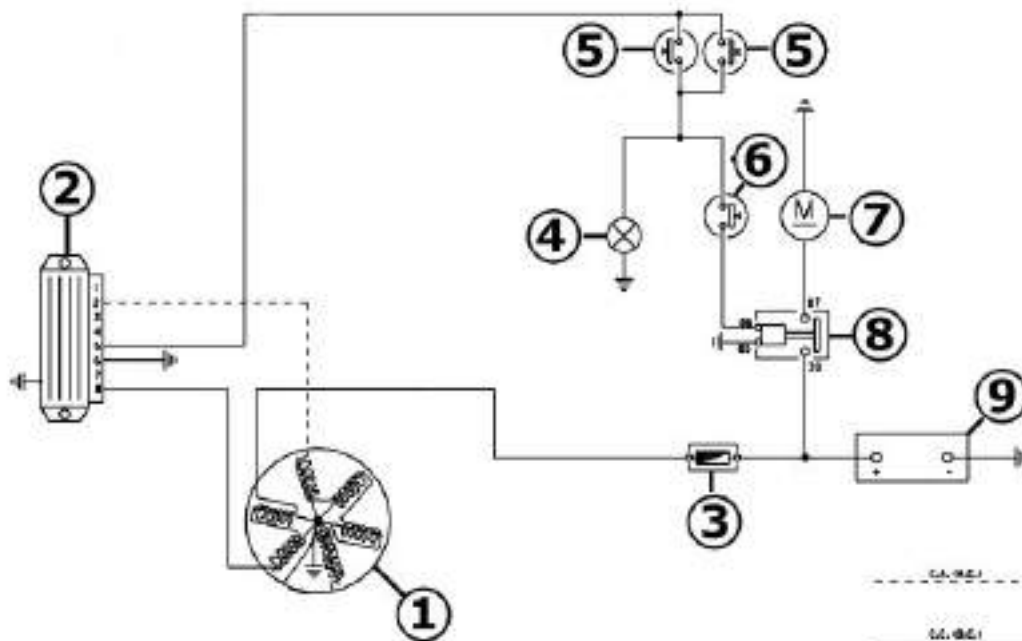

**BATTERY RECHARGE AND STARTING**

	Specification	Desc./Quantity
1	Magneto flywheel	
2	Voltage regulator	
3	Main fuse	7,5A
4	Brake light filament	12V - 21W
5	Front and rear brake light button	
6	Start up button	
7	Starter motor	
8	Remote starter switch	
9	Battery	12V - 4Ah



Level indicators and enable signals section

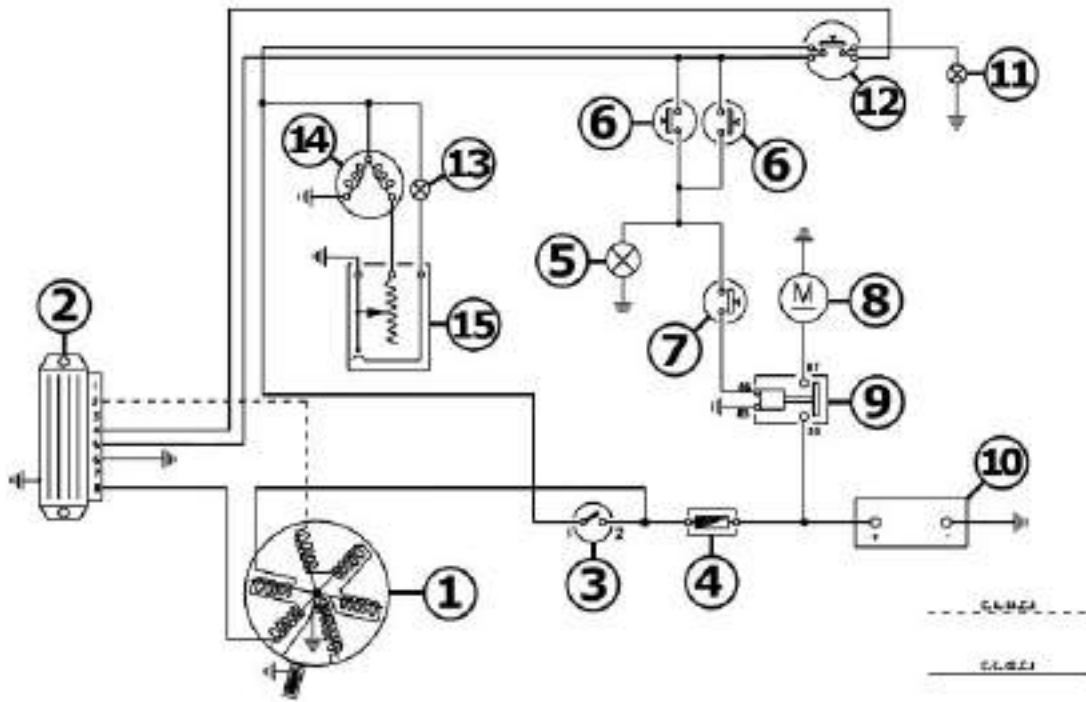

**START PERMISSIVE BUTTONS AND LEVEL INDICATORS**

	Specification	Desc./Quantity
1	Magneto flywheel	
2	Voltage regulator	
3	Key switch	
4	Main fuse	7,5A
5	Brake light filament	12V - 21W
6	Front and rear brake light button	
7	Start up button	
8	Starter motor	
9	Remote starter switch	
10	Battery	12V - 4Ah
11	Low oil warning light	12V - 1.2W
12	Oil level sender	
13	Low fuel warning light	12V - 1.2W
14	Fuel gauge	
15	Fuel level sender	

Turn signal lights

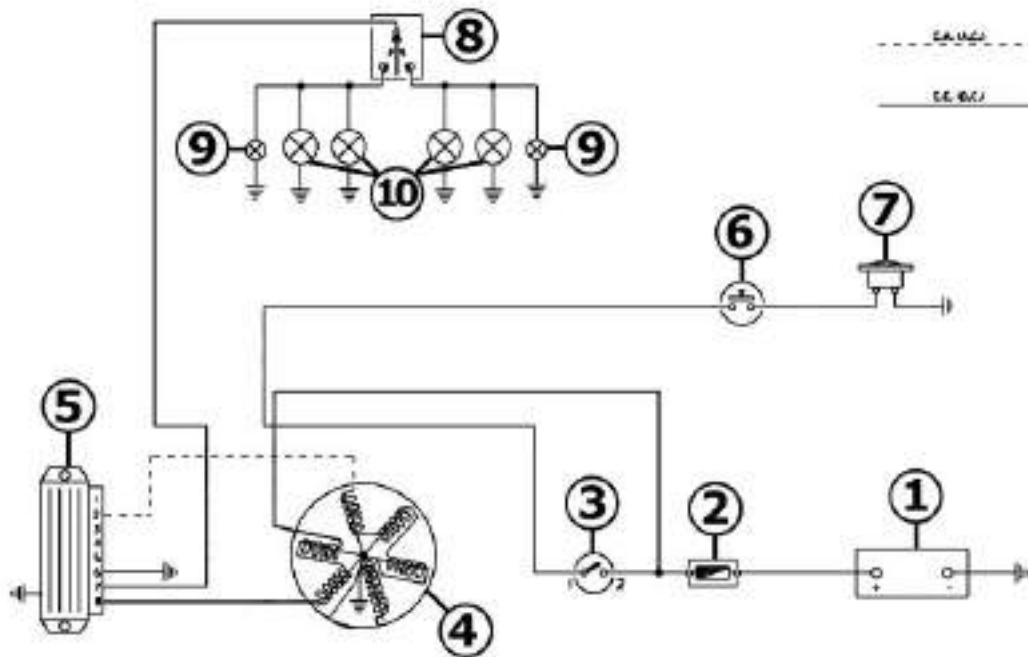

**TURN INDICATORS AND HORN**

	Specification	Desc./Quantity
1	Battery	12V - 4Ah
2	Main fuse	7,5A
3	Key switch	
4	Magneto flywheel	
5	Voltage regulator	
6	Horn button	
7	Horn	
8	Indicators switch	
9	Two (2) turn signal warning light bulbs	12V - 2W
10	4 Turn indicator bulbs	12V-10W

**Checks and inspections**

All the control operations of the system that entail disconnecting cables (to check connections and the devices making up the ignition circuit) must be done with the engine off: if this is not done, the controls might be irreparably damaged.

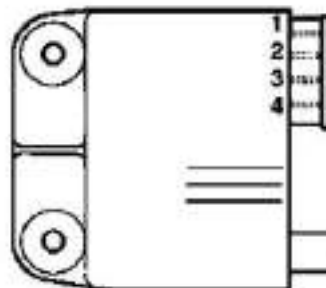

## Ignition circuit

1) Check the state of the spark plug (clean it with a metallic brush, remove all incrustations, blow it with compressed air, and replace it if necessary).

2) Without removing the stator, perform the checks described below:

After a visual inspection of the electrical connections, carry out the measurements on the charging coil and pick-up (see table), and check for continuity using the special tester, 020331Y.

If the continuity checks or the inspections on the coil and pick-up are incorrect, proceed by replacing the stator, otherwise replace the ECU.

Remember to detach the ECU wirings when the engine is not running.

### Specific tooling

020331Y Digital multimeter

**A**

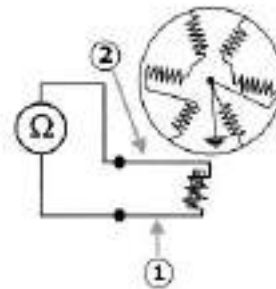

**B**

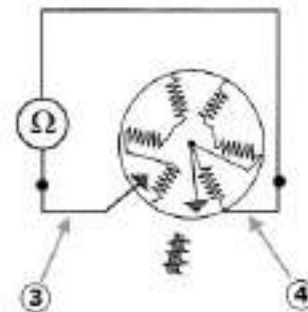

#### PICK - UP CHECK (FIGURE A)

	Specification	Desc./Quantity
1	Red cable (1) and White cable (2)	90 ÷ 140 Ohm

#### RECHARGING COIL CHECK (FIGURE B)

	Specification	Desc./Quantity
1	Red cable (3) and Green cable (4)	800 ÷ 1100 Ohm

#### CONTINUITY CHECK

	Specification	Desc./Quantity
1	White cable - Engine	Continuity
2	White cable - Frame	Continuity

## Voltage regulator check

### Voltage regulator

A fault in the voltage regulator can cause the following problems depending on the type of fault:

- 1) Blow out of the lighting system bulbs.
- 2) Failure of the lighting system.
- 3) Excessive battery charging (blowing of main fuse).
- 4) Battery recharging failure.
- 5) Failure of the turn indicators.

**A**

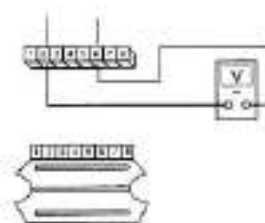

6) Failure of the oil and petrol check lamp.

### Operations

#### FAULT 1:

Make sure that at 5000 rpm with the lights on that the regulation voltage is between 13V and 14.5V.

Make sure that at 5000 rpm with the lights off the regulation voltage is  $\approx$  16V.

If the regulation voltage is greater than  $>16V$  replace the regulator.

#### FAULT 2:

a) Make sure the stator is supplying voltage correctly: disconnect the regulator connector and place tester 020331 y between the grey-blue wire (2) and the black wire (6) to measure the alternating voltage and make sure that the voltage supplied at 3000 rpm, is between 25 and 30V (FIG> A). If there are any anomalies, replace the stator.

b) If the tests do not reveal any anomalies, replace the regulator.

c) If replacement of the regulator does not restore correct operation, check the connections of the electrical system.

#### FAULT 3

After checking that there are no short circuits in the system towards earthing with the engine off and the regulator connector detached, replace the regulator because it is certainly inefficient, and replace the protection fuse.

Following the replacement, measure the current and the recharging voltage on the battery ends (FIG. B). The values detected must be  $1.5 \div 2 A$  and 13 V at 3000 rpm.

**B**

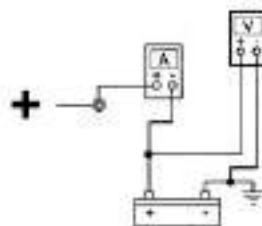

**FAULT 4**

a) By positioning tester 020331Y between the yellow wire terminal (8) on the regulator and the black wire (6) (FIG. D), check the generator output voltage is within 26 and 30 V at 3,000 rpm (this measurement must be carried out with the battery detached). In the event of anomalies, replace the stator; otherwise proceed to point b).

b) Yellow wire (1) attached to the regulator. Insert an ammeter between the stator's blue wire (2) and the battery, and check, using tester 020331Y, that the current output, at 3,000 rpm and with the battery kept between 12 and 13V, is approx. 1.5 - 2 A (FIG. C).

If the values thus obtained are lower than prescribed, proceed by replacing the regulator. Before carrying out inspections on the regulator and its electrical system, it is always advisable to check for continuity between the black wire and earth.

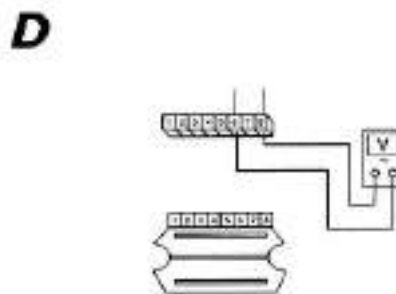
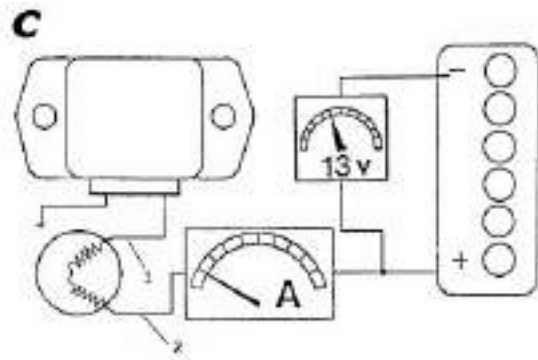
**FAULT 5**

(FIG. E) If the turn indicators do not work, proceed as follows:

- Remove the regulator connector, and insert the tester probes between the contact 5 (yellow-red) and the ground lead.
- Turn the key switch to ON and check that the battery is getting voltage. If no voltage is detected, check the wiring and the contacts on the key switch and on the battery.

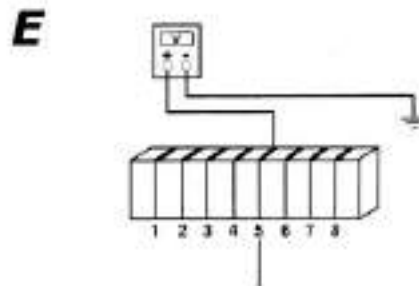

(FIG. F) Repeat the procedure now placing the tester probes between contacts 5 (yellow/ red) and 6 (black), and check the presence of the battery voltage with the key switch set to ON. If there is no voltage, check the regulator ground wiring.

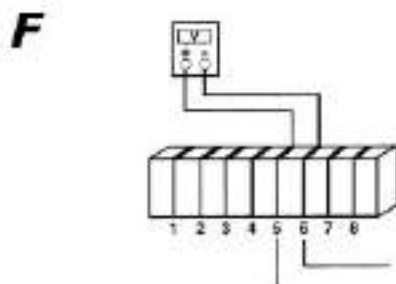

(FIG. G) If the above tests have positive results, jump the contacts 5 (yellow/red) and 7 (blue/black) on the connector, set the key switch to ON and shift the turn indicator switch to the right and left to see when the lights are steadily on (as they are powered directly from the battery). If even after this operation the turn indicators fail to turn on, check that the wiring is not damaged and the switch works properly. If these last two tests have a positive result, replace the regulator because it is certainly not functioning properly.

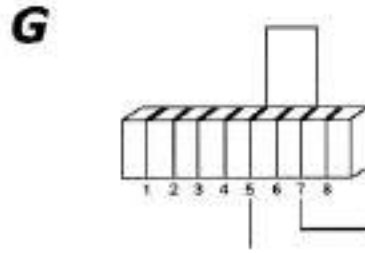

### FAULT 6

#### Oil reserve check warning light not working

(FIG H) - Disconnect the voltage regulator connector.

- Supply 12V to the terminal marked with number 5; with a digital tester check that the terminal number 4 has a similar output (12V) for about 5 seconds.
- If no voltage is detected for terminal number 4, replace the regulator.
- If there is voltage for terminal number 4, check both the installation and the bulb of the oil warning light.

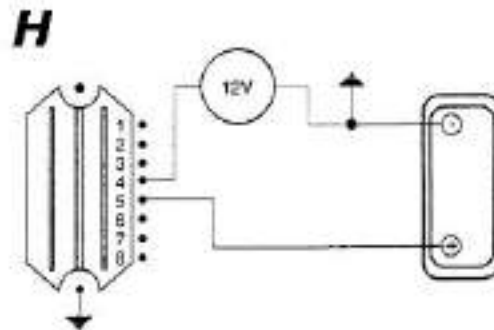

### Specific tooling

**020331Y Digital multimeter**

## Sealed battery

INSTRUCTIONS FOR REFRESHING THE STOCK CHARGE OF AN OPEN CIRCUIT

### 1) Voltage check

Before installing the battery on the vehicle, check the open circuit voltage with a normal tester.

- If the voltage exceeds 12.60 V, the battery may be installed without any renewal recharge.
- If voltage is below 12.60 V, a renewal recharge is required as explained in 2).

### 2) Constant voltage battery charge mode

- Constant voltage equal to 14.40÷14.70V
- Initial charge voltage equal to 0.3÷0.5 for nominal capacity
- Duration of the charge: 10 to 12 h recommended

Minimum 6 h

Maximum 24 h

### 3) Constant current battery charge mode

-Charge current equal to 1/10 of the nominal capacity of the battery

-Duration of the charge: 5 h

#### WARNING

**-WHEN THE BATTERY IS REALLY FLAT (WELL BELOW 12.6V) IT MIGHT BE THAT 5 HOURS OF RECHARGING ARE NOT ENOUGH TO ACHIEVE OPTIMAL PERFORMANCE. IN THESE CONDITIONS IT IS HOWEVER ESSENTIAL NOT TO EXCEED EIGHT HOURS OF CONTINUOUS RECHARGING SO AS NOT TO DAMAGE THE BATTERY ITSELF.**

## Dry-charge battery

#### WARNING

- Battery electrolyte is toxic and it may cause serious burns. It contains sulphuric acid. Avoid contact with eyes, skin and clothing. In case of contact with eyes or skin, flush abundantly with water for about 15 minutes and seek immediate medical attention.

In the event of accidental ingestion of the fluid, immediately drink large quantities of water or milk. Follow with milk of magnesia, beaten egg or vegetable oil. Seek immediate medical attention

Batteries produce explosive gases; keep clear of free flames, sparks or cigarettes; ventilate the area when recharging the battery indoors.

Always protect your eyes when working close to batteries.

**Keep out of the reach of children.**

The battery is an electrical device which requires careful monitoring and diligent maintenance. The maintenance rules are:

#### 1) Check the level of the electrolyte

The electrolyte level must be checked frequently and must reach the upper level. Only use distilled water, to restore this level.

If it is necessary to add water too frequently, check the vehicle's electrical system: the battery works overcharged and is subject to quick wear.

#### 2) Load status check

After restoring the electrolyte level, check its density using an appropriate densitometer (see the figure).

When the battery is charged, you should detect a density of 30 to 32 Bé corresponding to a specific weight of 1.26 to 1.28 at a temperature of no lower than 15° C.

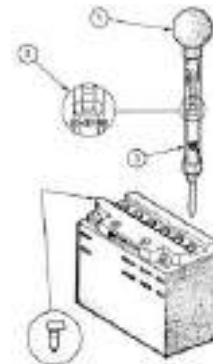

A density reading of less than 20° Bé indicates that the battery is completely flat and it must therefore be recharged.

After charging the battery, check each element electrolyte level and density. If the scooter is not used for a given time (1 month or more) it will be necessary to periodically recharge the battery.

The battery runs down completely in the course of three months.

If it is necessary to refit the battery in the vehicle, be careful not to reverse the connections, remembering that the earth wire (**black**) marked (-) must be connected to the - **negative** terminal while the other two **red** wires marked (+) must be connected to the terminal marked with the + **positive** sign.

Regular bench charging must be carried out with the specific battery charger, (single) or (multiple), setting the battery charger selector to the type of battery to be recharged. Connections to the power supply source must be implemented by connecting the corresponding poles (+ to+ and - to -).

#### 4) Cleaning the battery

The battery should always be kept clean, especially on its top side, and the terminals should be coated with Vaseline.

#### **WARNING**

- Before recharging the battery, remove the plugs of each cell. Keep the battery away from naked flames or sparks when charging.  
Remove the battery from the vehicle removing the negative clamp first.

#### **CAUTION**

**NEVER USE FUSES WITH A CAPACITY HIGHER THAN THAT RECOMMENDED.  
USING A FUSE OF UNSUITABLE RATING MAY SERIOUSLY DAMAGE THE VEHICLE OR EVEN CAUSE A FIRE.**

#### **CAUTION**

**DRINKING WATER CONTAINS MINERALS THAT CAN BE EXTREMELY HARMFUL TO THE BATTERY: USE DISTILLED WATER ONLY.**

#### **CAUTION**

**TO ENSURE MAXIMUM PERFORMANCE THE BATTERY MUST BE CHARGED BEFORE USE.  
INADEQUATE CHARGING OF THE BATTERY WITH A LOW ELECTROLYTE LEVEL BEFORE IT IS FIRST USED SHORTENS THE LIFE OF THE BATTERY.**



**Specific tooling****020333Y Single battery charger****020334Y Multiple battery charger**

---

- 1)- Remove the short closed tube and the caps, then pour sulphuric acid into the cells using the type specified for batteries, with a specific gravity of 1.26, corresponding to 30° Bé, at a minimum temperature of 15°C until the upper level is reached.
- 2) - Leave to rest for at least 2 hours; then, restore the level with sulphuric acid.
- 3)- Within the following 24 hours, recharge with the specific battery charger (single) or (multiple) at a density of about 1/10 of the battery nominal capacity and until the acid density is about 1.27, corresponding to 31° Bé, and these values are stabilised.
- 4) - Once the charge is over, level the acid (by adding **distilled water**). Close and clean carefully.
- 5)- Once the above operations have been performed, install the battery in the vehicle ensuring the connections between the wiring and the battery terminals are correct.

**WARNING**

**- ONCE THE BATTERY HAS BEEN INSTALLED IN THE VEHICLE IT IS NECESSARY TO REPLACE THE SHORT TUBE (WITH CLOSED END) NEAR THE + POSITIVE TERMINAL WITH THE CORRESPONDING LONG TUBE (WITH OPEN END), THAT YOU FIND FITTED TO THE VEHICLE, TO ENSURE THAT THE GASES THAT FORM CAN ESCAPE PROPERLY.**

**Specific tooling****020333Y Single battery charger****020334Y Multiple battery charger**

---

## INDEX OF TOPICS

ENGINE FROM VEHICLE

ENG VE

---

**Removal of the engine from the vehicle****Removing the engine from the frame**

---

- Disconnect the battery.
- Remove the muffler assembly.
- Remove the rear wheel.
- Remove the mechanical transmission of the rear brake.
- Disconnect the electric terminals.
- Remove the throttle grip and mixer transmissions.
- Disconnect the hoses (petrol-oil-vacuum-operated cock control).

**WARNING**

Be very careful when handling fuel.

**CAUTION**

When installing the battery, first attach the positive cable and then the negative cable.

**WARNING**

Wear safety goggles when using hitting tools.

---

## INDEX OF TOPICS

ENGINE

ENG

---

## Automatic transmission

---

### Transmission cover

- Loosen the 15 screws and remove the transmission cover with the aid of a mallet.

**N.B.**

**THE CRANKCASE IS SLIGHTLY BLOCKED BY THE TIGHT FIT BETWEEN THE SHAFT OF THE DRIVEN HALF-PULLEY AND THE BEARING HOUSED ON THE CRANKCASE.**

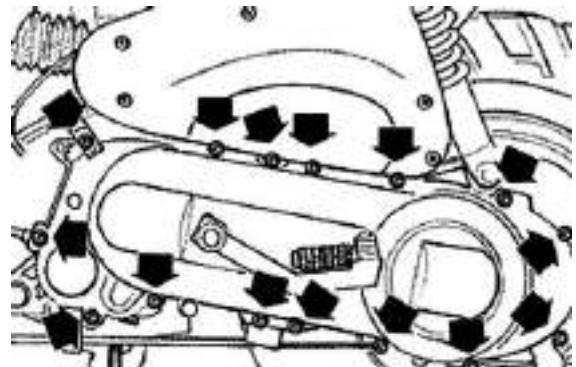



---

### Kickstart

- Remove the screws shown in the figure and remove the engine starting lever.
- For the assembly, work in reverse and tighten the screws to the prescribed torque..

#### Locking torques (N\*m)

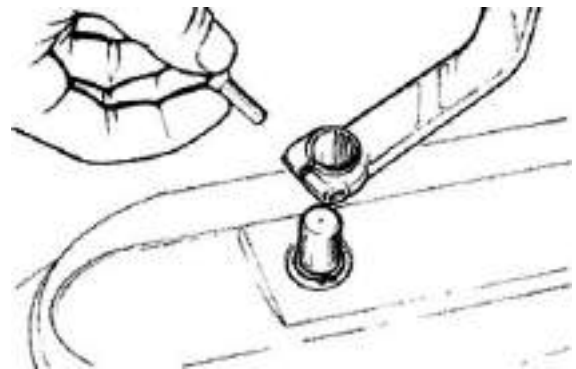
**Starter lever replacement 12 to 13 Nm**



- Upon refitting, apply the recommended grease to the bushing, to the spring and along the toothed sector.

- Use the special tool for the charging of the spring, as shown in the figure.

- Refit the seeger ring after checking that it is in good condition.



#### Specific tooling

**020261Y Starter spring fitting**

#### Recommended products

**AGIP GREASE MU3 Grease for odometer transmission gear case**

Soap-based lithium grease with NLGI 3; ISO-L-XBCHA3, DIN K3K-20

- 
- Remove the seeger ring located on the exterior of the crankshaft.
  - Dismantle the dog gear from its seat, slackening the tension that the toothed sector applies to it by means of the spring; to do this, it is necessary to rotate the toothed sector slightly (see the figure).

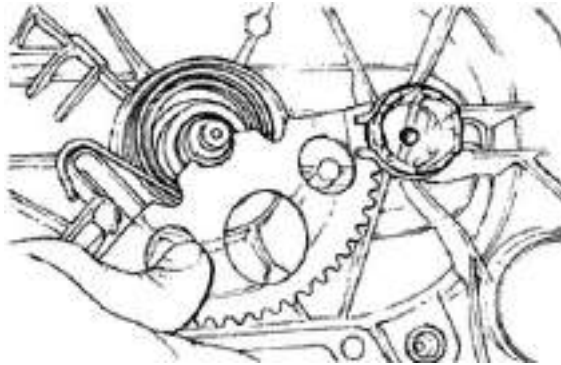
**CAUTION**

WHILE REMOVING THE TOOTHED SECTOR, BE VERY CAREFUL OF THE SPRING TENSION: IT COULD CONSTITUTE A HAZARD FOR THE OPERATOR.

---

## Removing the driven pulley shaft bearing

- Slightly heat the crankshaft from the inside side to avoid damaging the coated surface and use the driven pulley shaft or a pin of the same diameter to remove the bearing.

**N.B.**

IN CASE OF DIFFICULTY A STANDARD 8MM-INSIDE DIAMETER EXTRACTOR CAN BE USED.

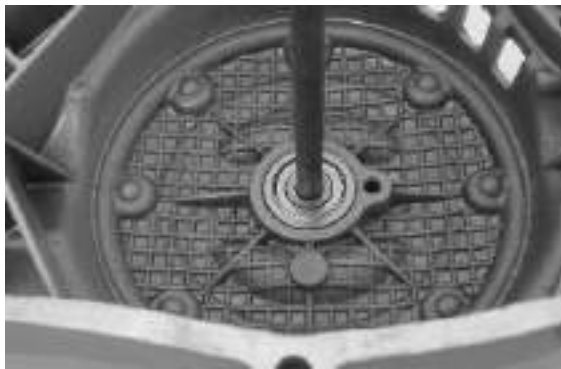

---

## Refitting the driven pulley shaft bearing

- Refit the bearing with the aid of a bushing with the same diameter as the external plate of the bearing after slightly heating the crankcase from the inside.

**N.B.**

WHEN REFITTING, ALWAYS REPLACE THE BEARING WITH A NEW ONE.

**CAUTION**

WHEN REMOVING/REFITTING THE BEARING, TAKE CARE NOT TO DAMAGE THE PAINTED SURFACE.

## Removing the driven pulley

- Lock the clutch bell housing with the specific tool.
- Remove the nut, the clutch bell housing and the whole of the driven pulley assembly.

**N.B.**

THE UNIT CAN ALSO BE REMOVED WITH THE DRIVING PULLEY MOUNTED.

### Specific tooling

020565Y Flywheel lock calliper spanner



## Inspecting the clutch drum

- Check that the clutch bell is not worn or damaged.
- Measure the inner diameter of the clutch bell.

### Characteristic

#### Clutch bell diameter/standard value

Ø 107+0.2 +0 mm

#### Clutch bell diameter/max. value allowed after use

Ø 107.5 mm

#### Eccentricity measured /max.

0.20 mm



## Removing the clutch

- Equip the tool with long pins screwed into position «A» from the outside, insert the entire driven pulley in the tool and put the central screw under stress.

**CAUTION**

THE TOOL WILL BE DEFORMED IF THE CENTRAL SCREW IS TIGHTENED UP TOO FAR.

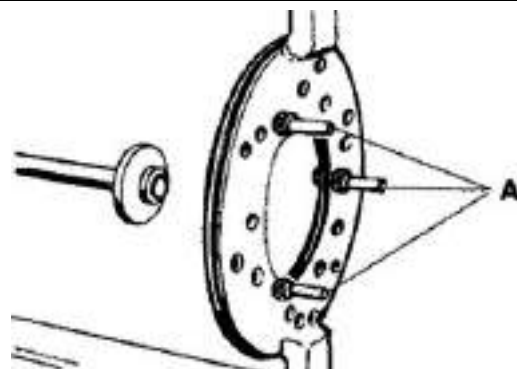

- Using a 34 mm socket wrench remove the clutch locking nut.
- Loosen the central screw thereby undoing the driven pulley unit
- Separate the components.

### Specific tooling

**020444Y Tool for fitting/ removing the driven pulley clutch**

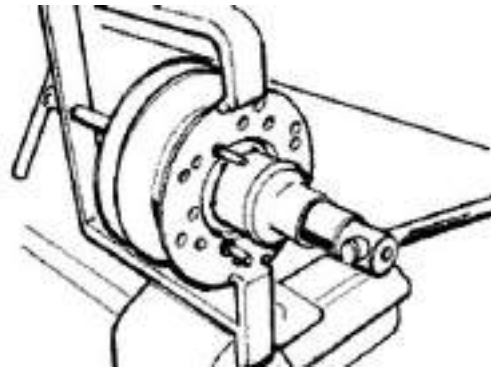

## Inspecting the clutch

- Check the thickness of the clutch mass friction material.
- The masses must not show traces of lubricants; otherwise, check the driven pulley unit seals.

### N.B.

**UPON RUNNING-IN, THE MASSES MUST EXHIBIT A CENTRAL FAYING SURFACE AND MUST NOT BE DIFFERENT FROM ONE ANOTHER. VARIOUS CONDITIONS CAN CAUSE THE CLUTCH TO TEAR.**

### CAUTION

**DO NOT OPEN THE MASSES USING TOOLS TO PREVENT A VARIATION IN THE RETURN SPRING LOAD.**

### Characteristic

#### Check minimum thickness

1 mm



## Pin retaining collar

- Remove the collar with the aid of 2 screwdrivers.





- Remove the three guide pins and the mobile half pulley.



## Removing the driven half-pulley bearing

- Remove the roller bearing with the special extractor inserted from the bottom of the fixed half-pulley.

### CAUTION

POSITION THE HOLDING EDGE OF THE EXTRACTION PLIERS BETWEEN THE END OF THE BEARING AND THE BUILT IN SEALING RING.

### Specific tooling

001467Y029 Bell for bearings, O.D. 38 mm



- Remove the ball bearing retention snap ring.
- Expel the ball bearing from the side of the clutch housing by means of the special tool.

### N.B.

PROPERLY SUPPORT THE HALF-PULLEY SO AS NOT TO DEFORM THE SLIDING SURFACE OF THE DRIVING BELT

### Specific tooling

020376Y Adaptor handle

020363Y 20-mm guide



## Inspecting the driven fixed half-pulley

- Check that there are no signs of wear on the work surface of the belt. If there are, replace the half-pulley..
- Make sure the bearings do not show signs of unusual wear.
- Measure the external diameter of the pulley bushing.

### Characteristic



**Stationary driven half-pulley/Standard diameter**

Ø 33.965 to 33.985 mm

**Stationary driven half-pulley / Minimum diameter admitted after use**

Ø 33.96 mm

**Inspecting the driven sliding half-pulley**

- Remove the 2 inner sealing rings and the two O-rings.
- Measure the inside diameter of the mobile half-pulley bushing.

**Characteristic****Mobile driven half-pulley/ Maximum diameter allowed**

Ø 34.08 mm



- Check the belt contact surfaces.
- Insert the new oil seal and O-rings on the mobile half-pulley.
- Fitting the half-pulley on the bushing.

**Recommended products****AGIP GREASE SM 2 Grease for the C-ring of the tone wheel**

Soap-based lithium grease containing NLGI 2 Molybdenum disulphide; ISO-L-XBCHB2, DIN KF2K-20



- Make sure the pins and collar are not worn, reassemble the pins and collar.
- Use a greaser with a curved spout to lubricate the driven pulley unit with around 6 g of grease. This operation must be done through one of the holes inside the bushing until grease comes out of the opposite hole. This procedure is necessary to prevent the presence of grease beyond the O-ring.

**Recommended products****AGIP GREASE SM 2 Grease for the C-ring of the tone wheel**

Soap-based lithium grease containing NLGI 2 Molybdenum disulphide; ISO-L-XBCHB2, DIN KF2K-20

## Refitting the driven half-pulley bearing

- Fit a new ball bearing with the specific tool.
- Fit the ball bearing retention snap ring.
- Fit the new roller bearing with the wording visible from the outside.

### CAUTION

PROPERLY SUPPORT THE HALF-PULLEY TO PREVENT DAMAGE TO THE THREADED END WHILE THE BEARINGS ARE BEING FITTED.

### Specific tooling

020376Y Adaptor handle

020456Y Ø 24 mm adaptor

020362Y 12 mm guide

020171Y Punch for Ø 17 mm roller case



## Inspecting the clutch spring

- Check that the contrast spring of the driven pulley does not show signs of deformation
- Measure the free length of the spring

### Characteristic

#### Standard length

118 mm

#### Minimum length allowed after use

XXXX



## Refitting the clutch

- Preassemble the driven pulley group with spring, sheath and clutch.
- Position the spring with the sheath
- Insert the components in the tool and preload the spring being careful not to damage the plastic sheath and the end of the threaded bar.



- Reassemble the nut securing the clutch and tighten to the prescribed torque.

**CAUTION**

SO AS NOT TO DAMAGE THE CLUTCH NUT USE A SOCKET WRENCH WITH SMALL CHAMFER.

**CAUTION**

POSITION THE NON-CHAMFERED SURFACES OF THE NUT IN CONTACT WITH THE CLUTCH

**Locking torques (N\*m)**

Nut locking clutch unit on pulley  $55 \div 60$  Nm

**Refitting the driven pulley**

- Refit the driven pulley assembly, the clutch bell and the nut, using the specific tool.

**Specific tooling**

020565Y Flywheel lock calliper spanner

**Locking torques (N\*m)**

Driven pulley shaft nut 40 to 44 Nm

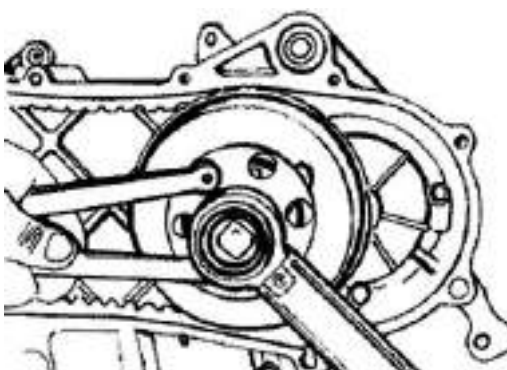
**Drive-belt**

- Make sure the driving belt is not damaged and does not have cracks in the toothed grooves.
- Check the width of the belt.

**Characteristic**

Transmission belt/Minimum width

17.5 mm

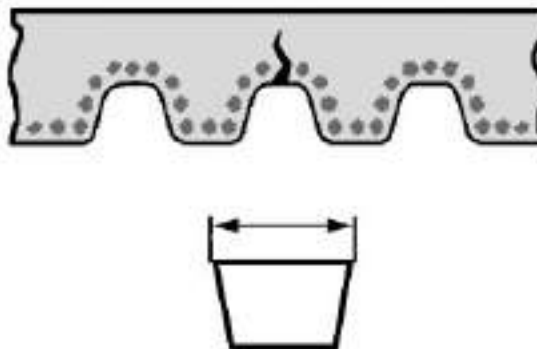

## Removing the driving pulley

- Lock the driving pulley using the appropriate tool.
- Remove the central nut with the related washer, then remove the drive and the plastic fan.
- Remove the stationary half-pulley.



- Remove the belt, washer and remove the mobile half-pulley with its bushing, being careful that the rollers and contrast plate fitted loosely on it do not come off.

### Specific tooling

**020451Y Starting ring gear lock**

## Mixer gears and belt

- Remove gear and belt.

#### CAUTION

PAY PARTICULAR ATTENTION TO NOT TOUCHING OR BENDING THE BELT BECAUSE THIS COULD BREAK SUDDENLY DURING OPERATION.

#### CAUTION

ON REFITTING, MAKE SURE THAT DIRT DOES NOT GET INTO THE INNER BUSHING OF THE MIXER CONTROL GEAR AND THAT IT DOES NOT EXERT ANY STRESS ON THE CRANKCASE PIN.

#### N.B.

REPLACE THE BELT EVERY 20000 KM.

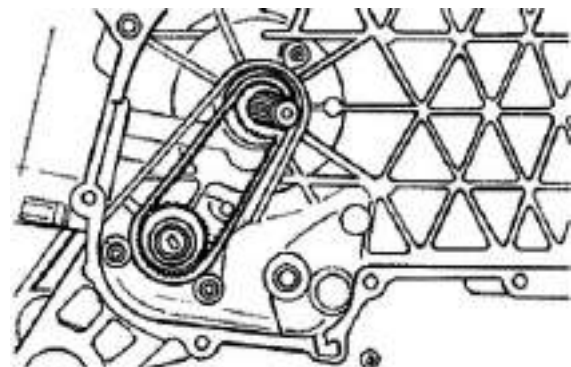

## Inspecting the rollers case

- 1) Check that the bushing and the sliding rings of the mobile pulley do not show signs of scoring or deformation.
- 2) Check the roller running tracks on the contact pulley; there must not be signs of wear and check the condition of the contact surface of the belt on the half-pulleys (mobile and stationary).
- 3) Check that the rollers do not show signs of marked facetting on the sliding surface and that the metallic insert does not come out of the plastic shell borders.

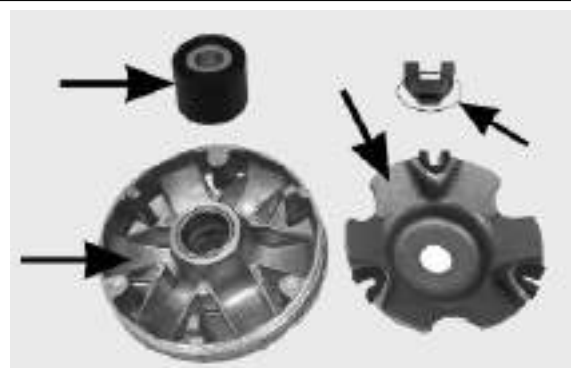

4) Check the integrity of the sliding blocks of the contact plate.

- Check that the internal bushing shown in the figure is not abnormally worn and measure inside diameter «A».

- Measure outside diameter «B» of the pulley sliding bushing shown in the figure.

**CAUTION**

DO NOT LUBRICATE OR CLEAN THE BUSHING.

**Characteristic**

**Driving pulley / Maximum diameter:**

20.12 mm

**Driving pulley/ Standard diameter:**

20.021 mm

**Driving pulley bushing/ Diameter maximum:**

XXX mm

**Driving pulley bushing/ Standard diameter:**

20 -0.020/-0.041mm

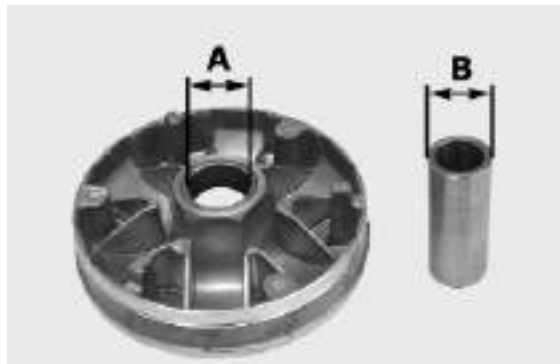

## Refitting the driving pulley

- Manually move the movable driven half-pulley away by pulling it towards the clutch unit and insert the belt observing the direction of rotation of the first fitting.

**N.B.**

IT IS GOOD PRACTICE ALWAYS TO FIT THE BELT SO THAT THE WORDS CAN BE READ IN CASE IT DOES NOT SHOW A FITTING SIDE.



- Refit the components of the assembly (roller container assembly with bushing, limiting washer, stationary half-pulley, cooling fan belt with drive, washer and nut).

- With the specific tool, tighten the lock nut to 20 Nm and then perform a final 90° locking in order to prevent the rotation of the driving pulley.

**N.B.**

REPLACE THE NUT WITH A NEW ONE AT EVERY REFIT

**CAUTION**

UPON FITTING THE DRIVING PULLEY UNIT IT IS OF UT-MOST IMPORTANCE THAT THE BELT IS FREE INSIDE IN



ORDER TO AVOID WRONG TIGHTENING AND CONSEQUENTLY DAMAGING THE CRANKSHAFT KNURLING.

## Specific tooling

020451Y Starting ring gear lock

## Locking torques (N\*m)

Crankshaft pulley nut 18 to 20 + 90° Nm

For 25 km/h engine type versions, the limit washer is 5.5 mm thick

---

## End gear

---

### Removing the hub cover

- Remove the transmission cover
- Remove the clutch assembly
- Discharge the rear hub oil.
- Remove the 5 screws indicated in the figure.
- Remove the hub cover with driven pulley shaft.

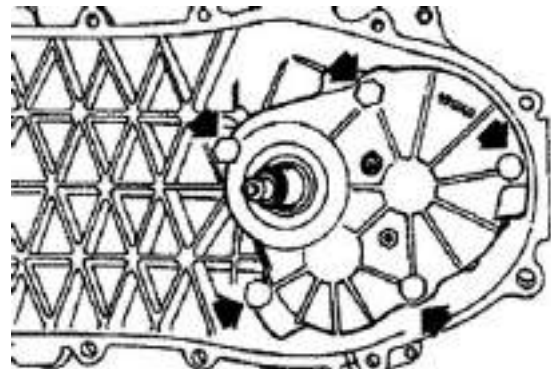

### See also

[Refitting the clutch](#)

---

### Removing the wheel axle

- Remove the intermediate gear and the complete gear wheel axle.
- When removing the intermediate gear pay attention to the various shim adjustments.

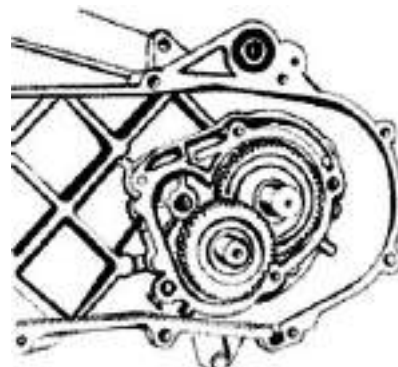

## Removing the wheel axle bearings

- Remove the oil seal and the Seeger ring.
- Remove the bearing by pushing from the outside towards the inside of the gear compartment, using the appropriate punch.

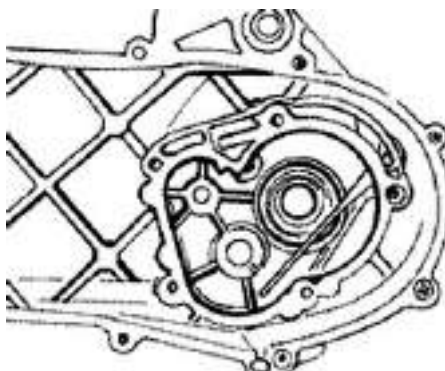

### Specific tooling

020363Y 20-mm guide

020376Y Adaptor handle

020358Y 37x40-mm Adaptor

## Removing the driven pulley shaft bearing

- Remove the Seeger ring inside the cover.
- Remove the oil seal from the outside.
- Remove the centring dowels and position the cover on a plane.
- Position the special tool on the internal track of the bearing and remove said bearing with the aid of a press.



### Specific tooling

020452Y Tube for removing and refitting the driven pulley shaft

- Position the special tube on the internal raceway of the bearing and from the shaft toothed side as indicated in the figure. Expel the driven pulley shaft with the aid of a press.



### Specific tooling

020452Y Tube for removing and refitting the driven pulley shaft



## Inspecting the hub shaft

- Check the three shafts for wear or distortion of the toothed surfaces, the bearing housings, and the oil seal housings.
- In case of anomalies, replace the damaged components.
- Check capacity ( A ) of the transmission gear (wear, deformations, etc.)
- Check the pulley shaft seating: Superficial wear ( B ) may indicate irregularities in the crankcase seatings or in the pulley shaft capacities

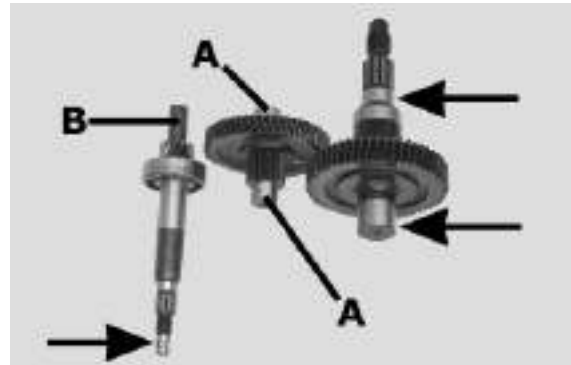

## Inspecting the hub cover

- Check that the fitting surface is not dented or distorted.
- If faults are found, replace the hub cover.

## Refitting the driven pulley shaft bearing

- Support the inner track of the bearing from the outside of the hub cover with the specific tool positioned under the press and insert the driven pulley axle.
- Refit the oil seal flush with the cover.

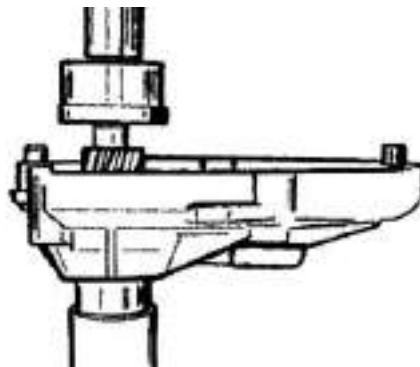

### Specific tooling

#### 020452Y Tube for removing and refitting the driven pulley shaft

- Heat the hub cover and insert the bearing with the specific punch.
- Fit the snap ring with the concave or radial part on the bearing side.

**N.B.**

**FIT THE BALL BEARING WITH THE SHIELD FACING THE OIL SEAL.**

### Specific tooling

**020151Y Air heater**

**020376Y Adaptor handle**

**020439Y 17-mm guide**

**020358Y 37x40-mm Adaptor**

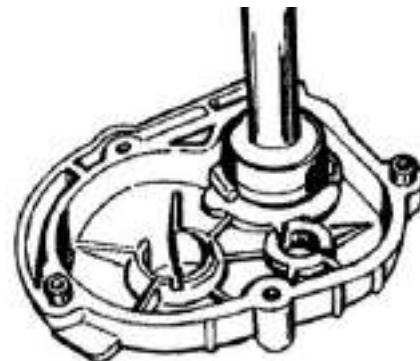

---

## Refitting the wheel axle bearing

- Heat the half crankcase on the transmission side using a thermal gun.
- After lubricating its outer strip, insert the bearing with the special adapter with the aid of a hammer.
- Refit the Seeger ring and the oil seal using the 42 x 47 mm adapter and the handle.

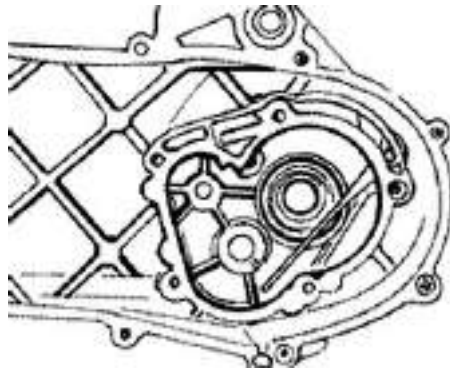

### Specific tooling

**020151Y Air heater**

**020376Y Adaptor handle**

**020363Y 20-mm guide**

**020359Y 42x47-mm Adaptor**

---

## Refitting the ub cover

- Refit the whole wheel axle.
- Refit the intermediate gear paying attention to the two shim washers.
- Apply LOCTITE 510 for surfaces to the hub covers and refit the same with driven pulley shaft.
- Refit the 5 screws and tighten them to the specified torque.

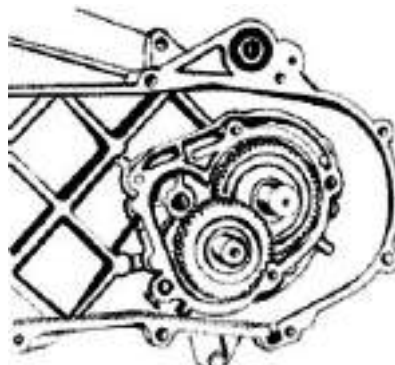

### N.B.

**CLEAN THE CONTACT SURFACES OF THE HUB COVER AND THE HALF CRANKCASE OF RESIDUE FROM PREVIOUS GASKETS BEFORE APPLYING A NEW ONE.**

### Locking torques (N\*m)

**Locking torque: 11 to 13 Nm**

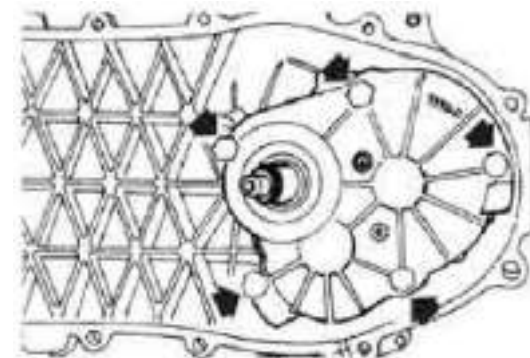

---

## Flywheel cover

---

---

**Cooling hood**

---

- Remove the four fixings shown in the figure.
- Remove the fan cover



- 
- Remove the oil piping retention band from the hood
  - Remove the 2 screws shown in the figure

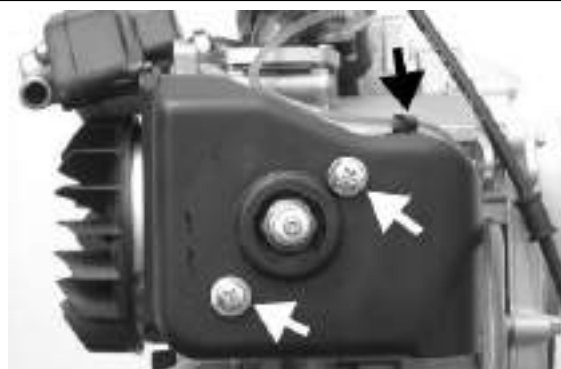

---

**Cooling fan**

---

- Remove the cooling fan by acting on the three fixings indicated in the figure.



---

## Removing the stator

- Remove the three stator fixings shown in the photo
- Remove the two pick-up fixings shown in the photo
- Remove the stator with the wiring

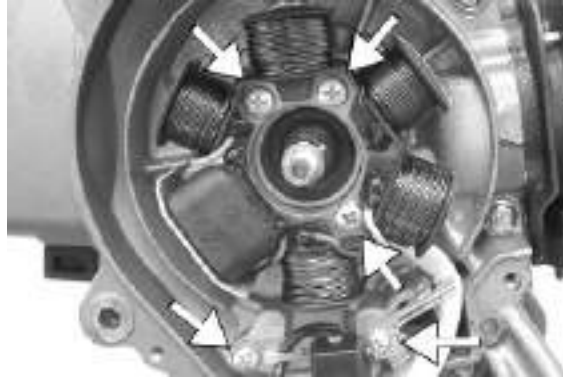

---

## Refitting the stator

- Refit the stator and flywheel carrying out the removal procedure in reverse, tightening the retainers to the specified torque.

**N.B.**

**THE PICK-UP CABLE MUST BE POSITIONED ADHERING TO THE FUSION TONGUE ON THE CRANKSHAFT IN SUCH A WAY AS TO AVOID BEING CRUSHED BY THE FAN COVER ASSEMBLY.**

**Locking torques (N\*m)**

**Pick-up screws 3 ÷ 4 Stator screws 3 ÷ 4**

---

## Flywheel and starting

---

### Removing the starter motor

Remove the two clamps shown in the figure



## Removing the flywheel magneto

- Lock the rotation of the flywheel using the calliper spanner.
- Remove the nut.

### CAUTION

THE USE OF A CALLIPER SPANNER OTHER THAN THE ONE SUPPLIED COULD DAMAGE THE STATOR COILS



- Extract the flywheel with the extractor.

### Specific tooling

020565Y Flywheel lock calliper spanner

020162Y Flywheel extractor



## Inspecting the flywheel components

- Check the condition of the flywheel and any distortions that might cause rubbing on the stator and on the Pick-Up.

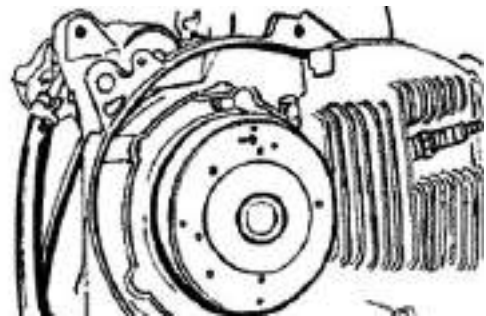

## Refitting the flywheel magneto

- Fit the flywheel being careful to insert the key properly.
- Lock the flywheel nut at the prescribed torque
- Check the Pick-Up air gap.
- The air gap may not be modified in the fitting of the Pick-Up.
- Other values derive from deformations visible on the Pick-Up support.



**N.B.**

A VARIATION OF THE AIR GAP DISTANCE CAN LEAD TO A VARIATION IN THE IGNITION ADVANCE SUCH AS TO CAUSE PINGING, KNOCKING ETC.

**Locking torques (N\*m)**

Flywheel nut 40 to 44 N.m

**Refitting the starter motor**

- Fit a new O-ring on the starter and lubricate it.
- Fit the starter on the crankcase, locking the two screws to the prescribed torque.

**N.B.**

REFIT THE REMAINING PARTS AS DESCRIBED IN THE CYLINDER HEAD, TIMING, LUBRICATION, FLYWHEEL AND TRANSMISSION CHAPTERS.

**Locking torques (N\*m)**

Starter screws 11 ÷ 13

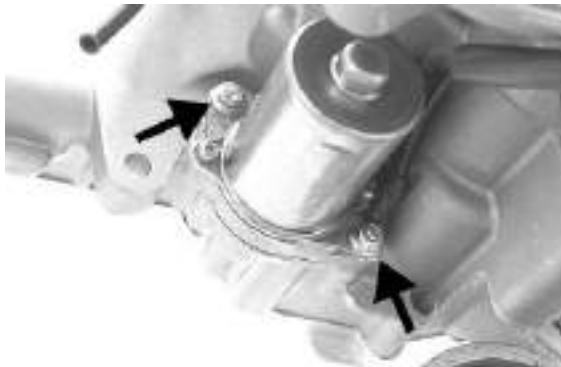
**Cylinder assy. and timing system****Removing the intake manifold**

Use an anti-tampering TORX spanner to remove the two clamping screws of the intake manifold

**Removing the cylinder head**

Remove the 4 screws shown in the figure



---

## Removing the cylinder - piston assy.

---

Remove the cylinder very carefully

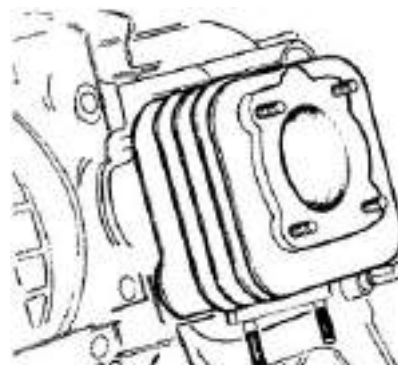

Remove the snap rings and remove the pin

**CAUTION**

AFTER EACH REMOVAL OPERATION REPLACE THE PIN RETENTION SNAP RINGS

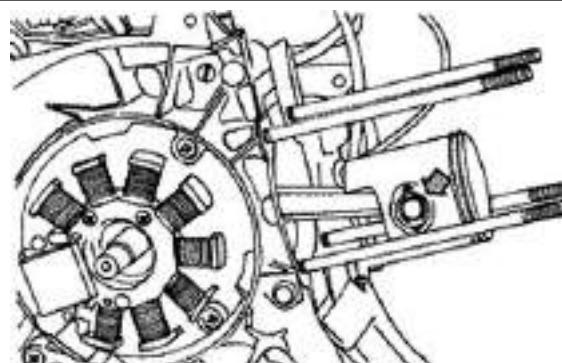

---

## Inspecting the small end

---

- Measure the internal diameter of the small end using an internal micrometer.

**N.B.**

IF THE DIAMETER OF THE ROD SMALL END EXCEEDS THE MAXIMUM DIAMETER ALLOWED, SHOWS SIGNS OF WEAR OR OVERHEATING REPLACE THE CRANKSHAFT AS DESCRIBED IN THE "CRANKCASE AND CRANKSHAFT" CHAPTER".

**Characteristic**

**Rod small end: standard diameter**

17 +0.011-0.001

**Rod small end: maximum allowable diameter**

17,060 mm



## Inspecting the wrist pin

- Check the wrist pin external diameter using a micrometer

### Characteristic

**Wrist pin: standard diameter**

12 +0.005 +0.001 mm



## Inspecting the piston

- Measure the bearings on the piston using a bore meter
- Calculate the piston-pin coupling clearance.

### Characteristic

**Wrist pin housing: standard diameter**

12 +0.007 +0.012

**Wrist pin housing: standard clearance**

0.002 ÷ 0.011 mm



- Measure the outer diameter of the piston, perpendicular to the pin axis.
  - Take the measurement in the position shown in the figure
- To classify the cylinder-piston fitting, check the appropriate table

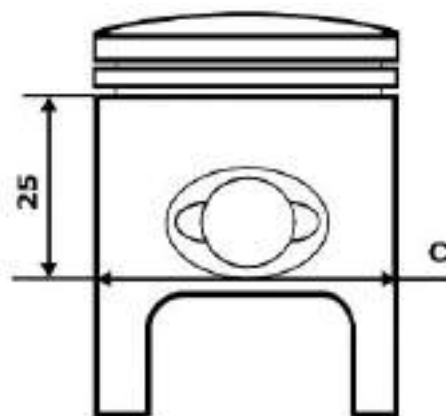

### See also

[Cylinder - piston assy.](#)



## Inspecting the cylinder

- Check that the cylinder does not show seizures. Otherwise, replace it or adjust it respecting the allowable increases

- Measure the internal diameter of the cylinder with a bore meter, according to the directions given in the figure

- Check that the fitting surface with the head is not dented or distorted.

To classify the cylinder-piston fitting, check the appropriate table

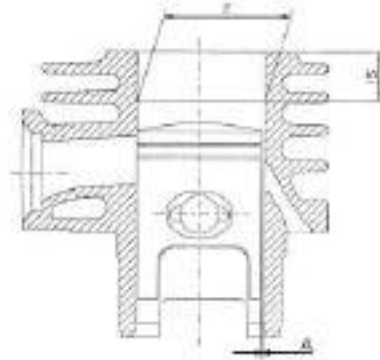

### See also

[Cylinder - piston assy.](#)

## Inspecting the piston rings

- Alternatively insert the two sealing rings in the cylinder

Using the piston, insert the seals perpendicularly to the cylinder axis.

- Measure the opening of the sealing rings using a thickness gauge as shown in the photograph

- If the values are higher than the values prescribed in the chart, substitute the rings



## Removing the piston

- Position the snap ring in detail 1 with the opening straddling the arrow printed on the tool.

-Push detail 2 into detail 1 until the stop and extract detail 2.

- Insert detail 3 into detail 1, position the assembly in the snap ring assembly area, and push detail 3 all the way in.

**N.B.**

**REFIT THE REMAINING PARTS FOLLOWING THE OPERATIONS IN REVERSE ORDER FROM THE REMOVAL OPERATIONS**

### Specific tooling

**020166Y Pin lock fitting tool**

**Locking torques (N\*m)**

**Locking head nuts: 10 to 11 N·m**

- Use new wrist pin snap rings.
- Use new cylinder base gasket.
- Before refitting carefully clean all the surfaces.
- Use oil to be mixed during the fitting of the piston and the cylinder.

**CAUTION**

POSITION THE ARROW PRINTED ON THE PISTON CROWN TOWARDS THE EXHAUST OPENING. THE WRIST PIN SNAP RINGS MUST BE POSITIONED ON THE PISTON WITH THE SPECIFIC TOOL

**Recommended products**

**AGIP CITY TEC 2T Oil**

Recommended oil

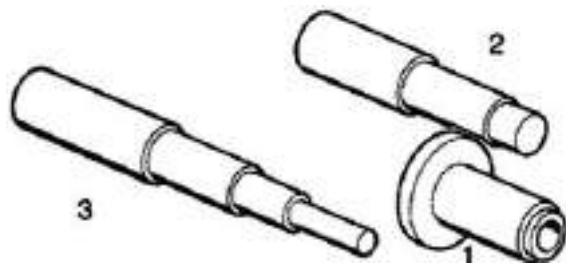

---

## Inspecting the timing system components

**CAUTION**

CHECK THE CORRECT REED UNIT SEAL; NO LIGHT MUST PASS BETWEEN THE SUPPORT AND LAMELLA.

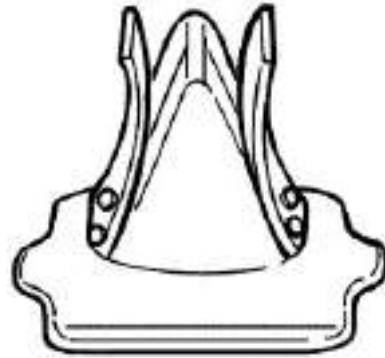

---

## Crankcase - crankshaft

---

### Splitting the crankcase halves

Remove the eight crankcase union fasteners.

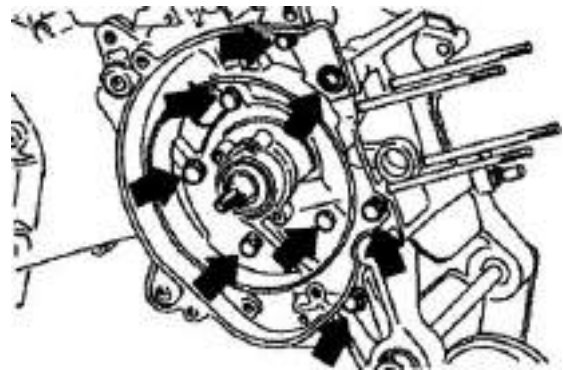

Install the special strip on the half crankcase on the flywheel side and separate the half crankcase on the flywheel side from the transmission side

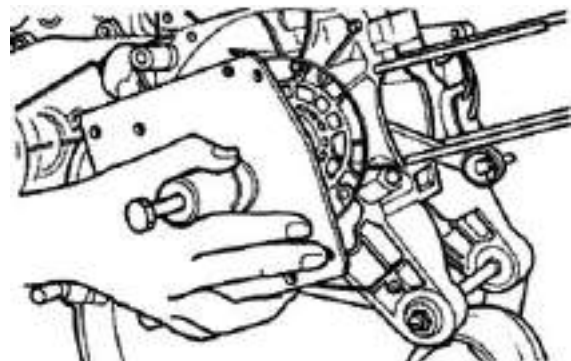
**Specific tooling**

**020163Y Crankcase splitting plate**

## Removing the crankshaft

- Install the specific tool on the half crankcase on the transmission side using four M6 screws of an adequate length.
- Remove the crankshaft from the transmission side half crankcase

### Specific tooling

**020163Y Crankcase splitting plate**

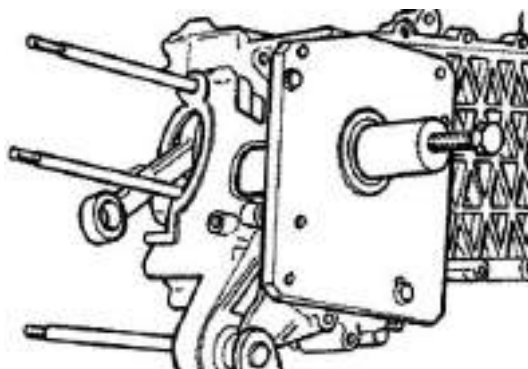

## Removing the crankshaft bearings

The bearings can stay on either the half crankcase or the crankshaft indifferently

- Using the special tool, remove any bearings that have been left on the crankshaft

### N.B.

The half rings must be inserted on the bearings with a few mallet blows.

### Specific tooling

**004499Y001 Bearing extractor bell**

**004499Y006 Bearing extractor ring**

**004499Y002 Bearing extractor screw**

**004499Y007 Half rings**

- Using the specific tool remove any bearings left on the half crankcase

### Specific tooling

**001467Y007 Driver for OD 54 mm bearing**

**001467Y006 Pliers to extract 20 mm bearings**

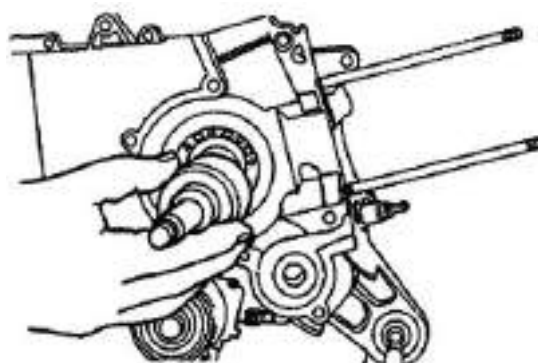

## Refitting the crankshaft bearings

Heat the bearings in an oil bath at around 150°C and fit them on the crankshaft, if necessary using a section of tube that acts on the bearing's inner track

### Specific tooling

020265Y Bearing fitting base



## Inspecting the crankshaft alignment

With the specific tool shown check that the eccentricity of the surfaces of diam. «A»-«B»-«C» are within 0.03 mm. (reading limit on the dial gauge); in addition, check the eccentricity of diam. «D», for which a maximum reading of 0.02 mm is permitted. In the case where eccentricity is not much above prescribed levels, **straighten** the shaft by acting on the counterweights with a shim or tighten them in a clamp (with an aluminium bushing) as required..

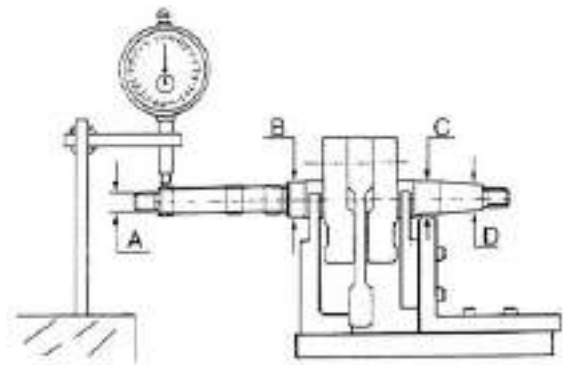

### Specific tooling

020335Y Magnetic support for dial gauge

020074Y Support base for checking crankshaft alignment

## Refitting the crankshaft

- Position the transmission side half crankcase on two wooden supports
- Using a thermal gun, heat the bearing seat to about 120°



- Firmly insert the crankshaft until the bearing reaches the end-of-stroke stop



- Let the temperature of the half crankcase settle at the temperature of the crankshaft.
- Again install the special crankcase separation plate **NOT** installing the crankshaft protection
- During the assembly phase keep the central thrust screw loose.
- Take the four clamping screws to the end of the stroke and loosen them again with the same angle (e.g. 90°)
- When the temperature has settled, preload the thrust screw of the tool manually until the ball bearing clearance is cancelled out.



### Specific tooling

**020163Y Crankcase splitting plate**

## Refitting the crankcase halves

- Prepare the coupling surface with LOCTITE 510 applying a thin layer of it after degreasing the surface using a suitable solvent (e.g. trichloroethylene)
- Heat the flywheel-side half crankcase with a thermal gun.

### Recommended products

**Loctite 510 Liquid sealant**

Gasket



- Keeping the half crankcase on the transmission side, insert the flywheel side half crankcase with a clean precise movement
- Insert at least three clamping screws and tighten up rapidly
- Insert the other 5 screws and tighten them to the specified torque.



### **Locking torques (N\*m)**

#### **crankcase coupling screws 11 - 13**

- Move the crankcase separation plate in a position back from the one indicated in the figure
  - Install the special magnetic support with dial gauge at the end of the crankshaft
  - Check the axial clearance of the crankcase
- If this is not within the maximum limit allowed, repeat the crankcase coupling procedure



### **Specific tooling**

#### **020335Y Magnetic support for dial gauge**

#### **Characteristic**

##### **Axial clearance with warm crankcase**

0.10 ÷ 0.12 mm

##### **Axial clearance with cold crankcase**

0.06 to 0.08 mm

##### **Limit value with cold crankcase**

0.02 ÷ 0.03 mm

---

## **Lubrication**

---

## **Crankshaft oil seals**

---

---

## Refitting

- Install a new flywheel-side oil seal only with the special tool's punch

The flywheel-side oil seal is recognised by its smaller diameter

**N.B.**

**THE USE OF THE SPECIFIC TOOL IS NOT COMPATIBLE WITH THE FITTED WRENCH**

### Specific tooling

**020340Y Flywheel and transmission oil seals fitting punch**



- Install a new transmission side oil seal using the special tool with adapter ring.

The transmission-side oil seal is recognised by the larger diameter

### Specific tooling

**020340Y Flywheel and transmission oil seals fitting punch**



---

## Oil pump

---

### Removal

- Remove the 2 screws shown in the figure





Remove the tube passage seal from the crankcase shown in the figure

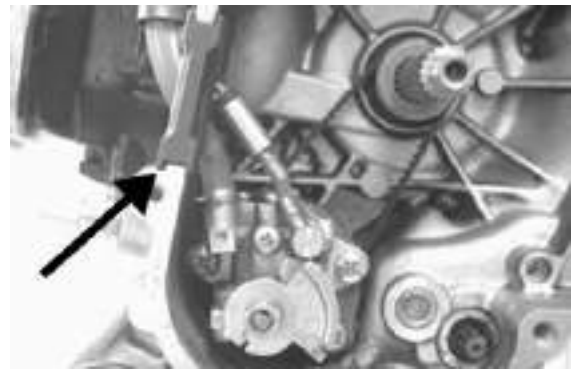

## Refitting

To refit, perform the steps in the reverse direction to disassembly

Remember to drain after refitting using the screw shown in the figure

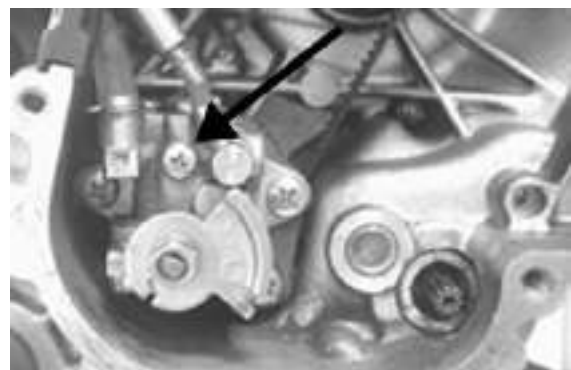

## Fuel supply

- Disconnect the fuel supply and the suction taking pipe from the carburettor.
- Check that there are no fuel leaks between the two tubes.
- Close the fuel outlet pipe.
- By means of the MITYVAC pump apply 0.1 bar of suction to the tap.
- Make sure that the suction is kept stable and that there are no fuel leaks.
- Reconnect the suction pipe to the manifold.
- Position the fuel pipe with the outlet at the point of the tap.
- Turn the engine by using the starter for five seconds with the carburettor at minimum.
- Take up the fuel by means of a graded burette.

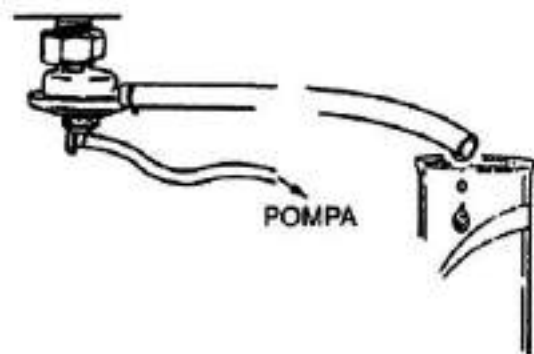

### N.B.

THE MEASUREMENT MAY BE FALSIFIED BY THE INCORRECT NUMBER OF REVS OR BY THE WRONG POSITION

OF THE TUBE. IN THIS CASE, THE TENDENCY IS TO OBTAIN A REDUCED FUEL FLOW RATE. THE SUCTION OUTLET ON THE MANIFOLD HAS A SECTION INTENTIONALLY REDUCED FOR THE PURPOSE OF ENHANCING THE SUCTION PULSATION AND THEREBY GUARANTEE A CONSTANT TAP FLOW RATE.

### Specific tooling

020329Y Mity-Vac vacuum-operated pump

### Characteristic

#### Minimum flow rate

20 cc

- Completely empty the fuel tank.
- Remove the petrol delivery pipe and the low-pressure pipe.
- Loosen the clip and remove the cock.
- Clean the tank and the filter of the cock with a specific solvent.
- Refit the cock making sure that there is an O-Ring.
- Turn the cock to the direction it had before it was removed and block the clip.

#### N.B.

THE FILTER CAN BE UNSCREWED FROM THE COCK TO FACILITATE CLEANING.

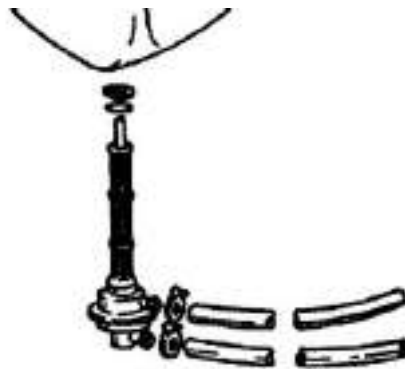

## INDEX OF TOPICS

**SUSPENSIONS**

**SUSP**

---

This section is devoted to operations that can be carried out on the suspension.

---

## Front

---

### Removing the front wheel

---

- Remove the five Allen screws that fix the wheel to the hub.

**N.B.**

**BEFORE REMOVING THE WHEEL HUB, REMOVE THE BRAKE CALLIPER.**

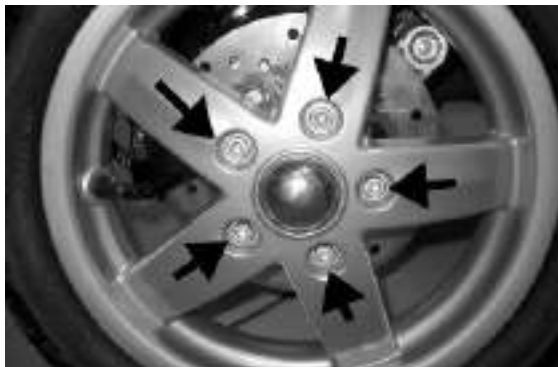

---

### Front wheel hub overhaul

---

- Remove the ball bearing check Seeger ring indicated in the picture



Extract the ball bearing using the specific tool

#### Specific tooling

001467Y014 Pliers to extract  $\varnothing$  15-mm bearings

001467Y017 Bell for bearings, OD 39 mm



- Remove the oil seal on the roller bearing side using a screwdriver.



- Remove the roller bearing using the specific tool

#### Specific tooling

**020376Y Adaptor handle**

**020456Y Ø 24 mm adaptor**

**020363Y 20-mm guide**



- Heat the roller bearing seat with a heat gun
- Use the specific tool to introduce and push the bearing until it stops, with the shielded side facing out
- Refit the ball bearing check Seeger ring

#### Specific tooling

**020151Y Air heater**

**020376Y Adaptor handle**

**020359Y 42x47-mm Adaptor**

**020412Y 15-mm guide**



- Use the specific tool to fit and push the roller casing until it stops
- Refit the oil seal on the roller bearing side
- Lubricate the area between the roller bearing and the ball bearing

#### Specific tooling

**020038Y Punch**

#### Recommended products

**AGIP GREASE MU3 Grease for odometer transmission gear case**



Soap-based lithium grease with NLGI 3; ISO-L-XBCHA3, DIN K3K-20

## Refitting the front wheel

- When refitting, tighten the 5 screws to the specified torque

### Locking torques (N\*m)

Nut tightening torque 20 to 25 N\*m



## Handlebar

### Removal

Remove the handlebar cover before carrying out this operation,.

- After removing the transmissions and disconnecting the electrical terminals, remove the terminal fixing the handlebar to the steering.
- Check all components and replace faulty parts.

#### N.B.

**IF THE HANDLEBAR IS BEING REMOVED TO REMOVE THE STEERING, TILT THE HANDLEBAR FORWARD TO AVOIDING DAMAGING THE TRANSMISSIONS.**

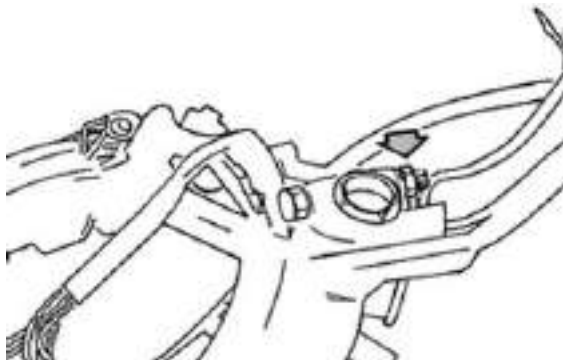

### Refitting

Carry out the removal operations but in the reverse order, observing the prescribed tightening torque.

### Locking torques (N\*m)

Handlebar fixing screw 50 ÷ 55



## Steering column

### Removal

After removing the upper seat, lean the vehicle on one side and extract the steering tube completely from the fork.

#### Specific tooling

**020055Y Wrench for steering tube ring nut**



### Overhaul

-The front suspension service operation is useful to replace the connecting parts between the steering tube and the swinging hub of the front wheel holder, provided that the steering tube and the wheel holder hub are in excellent conditions.

- Press and remove the wedging washer with the help of a pointed end.
- For the second washer, repeat the operation using the punch on the side opposite to the one shown in the figure.

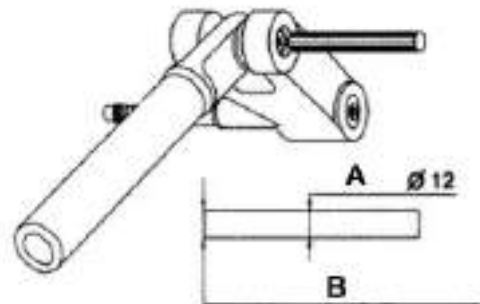

**A** = Ø12 Punch

**B** = Sharp-edged end

- Use the specific tool, fitted with part 1\*, and operate the handgrip until the pin and the Nadella are simultaneously ejected in the direction opposite the tool thrusting force.
- To eject the second Nadella, use the tool fitted with part 2\* instead of part 1, on the side opposite the one shown in the figure.

\* Supplied with the tool

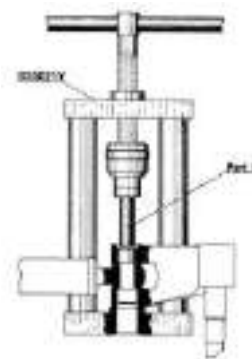

## Specific tooling

### 020021Y Front suspension service tool

- Use the tool fitted with part 20\* and part 21\* on its stem as shown in the figure.
- Push the two roller casings with the handgrip until their bottoms make contact with the pin end.

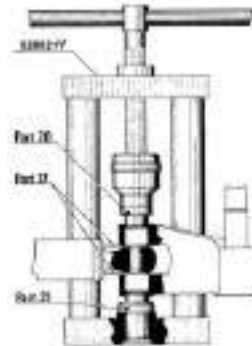

- Fit both dust guard rings «C» on the swinging hub as shown in the detail drawing «A».
- Connect the swinging hub to the steering tube with the guide pin, part 5\*.
- Use the specific tool fitted with part 3\* on its stem and with part 4 at the bottom of the tool.
- Insert the previously greased pin on the swinging hub and with the tool handgrip, move part 3 until it stops on the steering tube.
- After fitting the pin, insert the two spacers, part 17\*, slightly hitting with the mallet.

\* Supplied with the tool

## Specific tooling

### 020021Y Front suspension service tool

#### Recommended products

#### AGIP GREASE PV2 Grease for control levers on the engine

White anhydrous-calcium based grease to protect roller bearings; temperature range between -20 °C and +120 °C; NLGI 2; ISO-L-XBCIB2

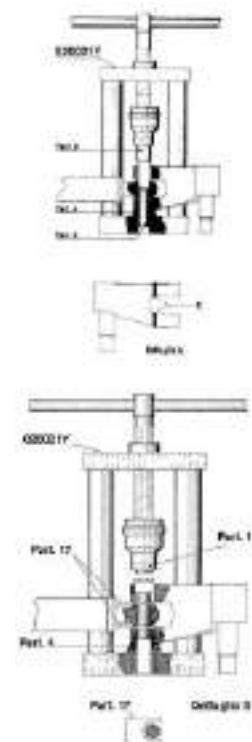



- Lubricate the sealing rings with mineral oil and half-fill the roller casings with grease.
- Insert the sealing ring on the pin and the roller bushing with wedging washers at the same time.
- Remove the specific tool, then the part 5 (guiding) partially ejected in the previous assembly stage; leave part 4\* always fitted.
- Replace part 3 with part 16\* on the stem.
- Push, from the handgrip, the wedging washer - roller casing - sealing ring unit, placing part 16 until it stops on the swinging hub
- Repeat the operation described above using the tool fitted with part 16 and part 22\* instead of part 4 on the stem, on the side opposite the one shown in the figure to refit the second wedging washer - roller casing - sealing ring unit.

\* Supplied with the tool

### Specific tooling

#### 020021Y Front suspension service tool

#### Recommended products

#### AGIP GREASE PV2 Grease for control levers on the engine

White anhydrous-calcium based grease to protect roller bearings; temperature range between -20 °C and +120 °C; NLGI 2; ISO-L-XBCIB2

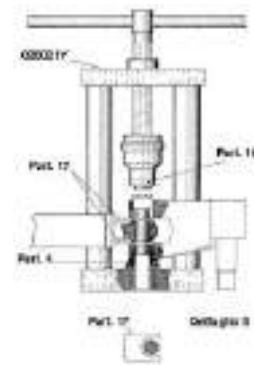

Use the tool fitted with parts 3 and 4, as indicated to fit the pin, and press operating the handgrip, until wedging the washers on the swinging hub.

- Remove the spacers, part 17, fill with grease the area between the steering tube and the swinging hub, and place the dust guard rings in that place.

\* Supplied with the tool

**N.B.**

**ASSEMBLE THE LOWER HOUSING ON THE STEERING TUBE WITH A TUBE SECTION OF AN ADEQUATE DIAMETER.**

### Specific tooling

#### 020021Y Front suspension service tool

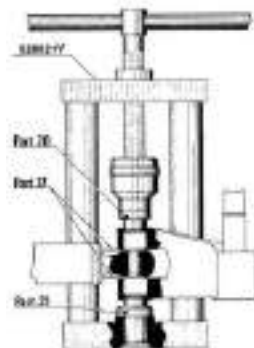

**001330Y Tool for fitting steering seats****Recommended products****AGIP GREASE PV2 Grease for control levers on the engine**

White anhydrous-calcium based grease to protect roller bearings; temperature range between -20 °C and +120 °C; NLGI 2; ISO-L-XBCIB2

---

**Refitting****CAUTION**

**USE NEW ROLLER CASINGS, PIN, SEALING RINGS AND DUST GUARDS FOR REFITTING.**

---

When fitting the fork, lubricate with the steering bearing tracks with the recommended grease. Tighten the lower ring nut "A" and the upper ring nut "B" to the specified torque

**Recommended products****AGIP GREASE PV2 Grease for the steering bearings, pin seats and swinging arm**

White anhydrous-calcium based grease to protect roller bearings; temperature range between -20 C and +120 C; NLGI 2; ISO-L-XBCIB2.

**Locking torques (N\*m)**

**Steering lower ring nut  $8 \div 10$  Upper steering ring nut  $35 \div 40$**

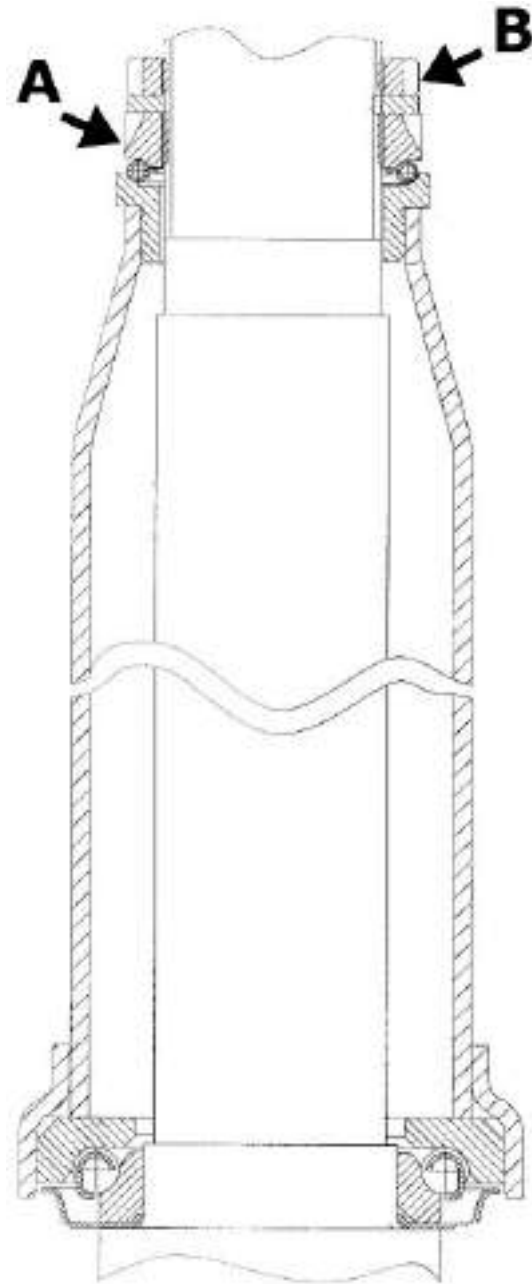
**Front shock absorber**

---

## Removal

- Remove the steering tube
- Remove the shock absorber lower clamps
- Remove the shock absorber upper clamps



---

## Refitting

To refit, carry out the removal operations in reverse order, observing the prescribed tightening torques.

### Locking torques (N\*m)

shock absorber lower clamp 20 - 27 shock absorber upper clamp 20 ÷ 30

---

## Shock-absorber - calliper bracket

---

### Removal

- Remove the front wheel hub with the brake disc
- Remove the front shock absorber lower clamps



- Remove the bracket locking Seeger ring
- Unscrew the bracket



- Before refitting the bracket in the wheel axle, place the O-ring as shown in the photograph so that it is correctly placed after fitting the bracket.
- Refit the washer and the Seeger ring.
- Refit the lower screws fixing the shock absorber to the bracket and tighten at the prescribed torque

**Locking torques (N\*m)**

**Lower shock absorber clamp** 20 ÷ 27

**Overhaul**

- The bracket for the shock absorber -calliper attachment has two roller bearings separated one from the other as shown in the photograph



- Remove the two roller bearings from the bracket with the specific tool operating on the shock absorber attachment side as shown in the photograph

**Specific tooling**

**020376Y Adaptor handle**

**020441Y 26 x 28 mm adaptor**

**020365Y 22 mm guide**

- Remove the oil seal on the wheel hub side with the screwdriver as shown in the photograph



- Suitably hold the brake calliper - shock absorber attachment bracket

- Fit a new oil seal and move it until it stops using the specific tool

### Specific tooling

**020376Y Adaptor handle**

**020360Y 52x55-mm Adaptor**



- Assemble a new roller bearing on the shock absorber side and move it until it stops using the specific tool

### Specific tooling

**020036Y Punch**



- Suitably hold the brake calliper - shock absorber attachment bracket

- Assemble a new roller bearing on the wheel hub side and move it until it stops using the specific tool

### Specific tooling

**020037Y Punch**



## Steering bearing

### Removal

- Use the specific tool both to remove the lower seat of the upper bearing and to remove the upper seat of the lower bearing fitted on the chassis.

**N.B.**

**TO REMOVE THE LOWER SEAT OF THE LOWER STEERING BEARING JUST USE A SCREW-DRIVER AS A LEVER BETWEEN THE SEATING AND THE SLEEVE.**

### Specific tooling

**020004Y Punch for removing fifth wheels from headstock**

---

- Remove the fifth wheel fitting and the dust guard on the steering tube as shown in figure, using the specific tool. Proceed giving a few taps with the mallet.

**Specific tooling**

**020004Y Punch for removing fifth wheels from headstock**



---

- Refit the fifth wheel fitting and the dust guard on the steering tube until they stop, using the specific tool.

**Specific tooling**

**006029Y Punch for fitting fifth wheel seat on steering tube**



---

## Rear

---

### Removing the rear wheel

- 
- Use a screwdriver as a lever between the drum and the cover.
  - Straighten the split pin and remove the cap.
  - Remove the wheel acting on the central fixing point.

**WARNING**

**-ALWAYS USE NEW SPLIT PINS FOR REFITTING.**

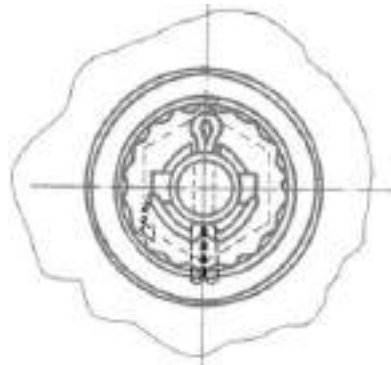

---

## Refitting the rear wheel

- Fit the wheel, tighten the nut to the prescribed torque.
- Refit the cap and the split pin folding it correctly as shown in the figure.

### Locking torques (N\*m)

Locking torque 137 ÷ 152 Nm

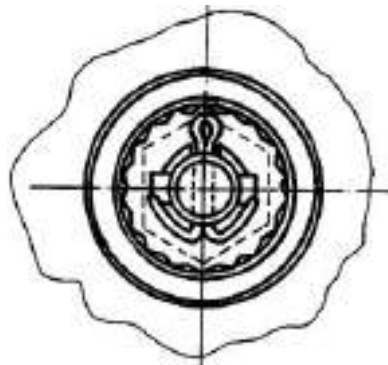

---

## Swing-arm



---

## Removal

Remove the swinging arm acting on the three clamps shown in the figure.







---

## Refitting

For refitting, respect the locking torques

**Locking torques (N\*m)**

**Part C 33 ÷ 41 Part B 44 ÷ 52 Part A 33 ÷ 41**

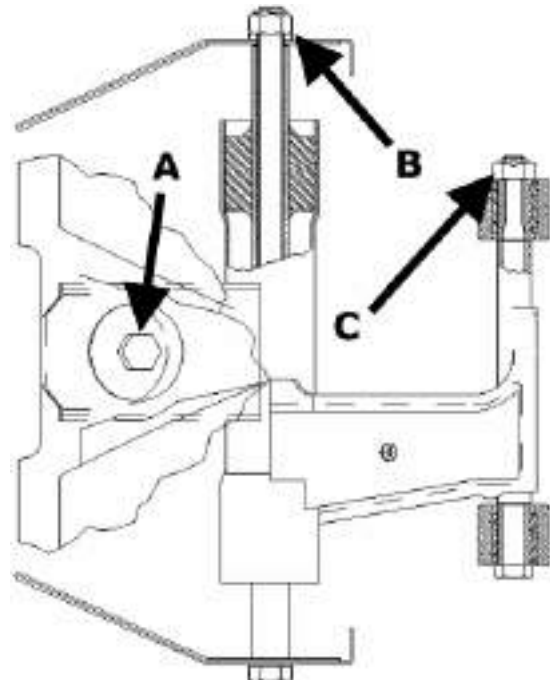

---

## Shock absorbers

---

## Removal

- To replace the shock absorber remove the battery access flap to reach and remove the shock absorber/ frame anchoring nut. Then remove the shock absorber/engine anchorage nut.
- When refitting, tighten the shock absorber/chassis anchoring nut and the shock absorber/engine pin to the prescribed torque.

### Locking torques (N\*m)

**Shock absorber/engine pin torque 33 to 41 N·m**

**Shock absorber/frame nut torque 20 to 25 Nm**

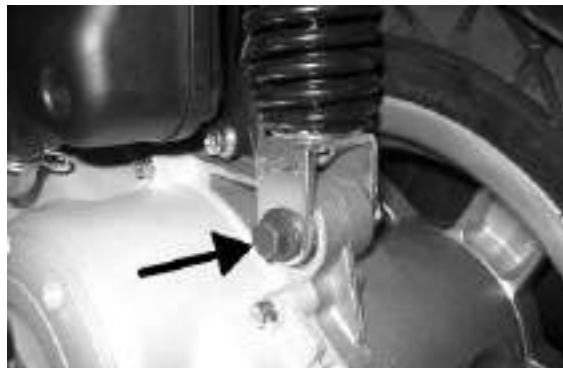

## INDEX OF TOPICS

**B**RAKING SYSTEM

**BRAK SYS**

1. Tank cover.
- 2 - Pump body.
- 3 - Brake lever.
- 4 - Pump plunger.
- 5- Oil delivery hose.
- 6 - Protection cap for air bleed screw.
- 7- Calliper.
- 8- Dust guard
- 9- Piston sealing ring.
- 10- Piston.
- 11 - Brake pad.
- 12 - Brake disc.

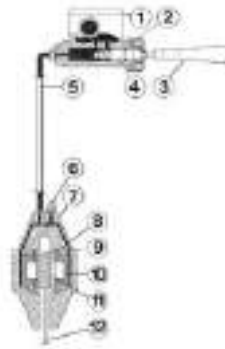

## Front brake calliper

### Removal

- Detach the oil brake hose from calliper, pouring the fluid inside a container.
- Remove the mountings indicated in the figure.
- When refitting, tighten the nuts to the prescribed torque.
- Bleed the system.



### Locking torques (N\*m)

**Calliper tightening screw** 20 ÷ 25 Nm **Brake fluid tube calliper** 20 ÷ 25

### Overhaul

- Remove the calliper assembling bolts and take out the internal bodies and components. If necessary, in order to make it easier to take out the plungers, inject (shorts blasts of) compressed air through the brake fluid pipe.
- Check that the cylinders of the internal and external body of the calliper do not show scratches or signs of erosion; otherwise, replace the entire calliper.

#### CAUTION

**ALL THE INTERNAL COMPONENTS MUST BE REPLACED EVERY TIME THE CALLIPER IS SERVICED.**

Fit to the calliper body:

- the sealing rings (1-2);
- the plungers (3);

- bed the O-Ring gasket (4) on a calliper body.
- Couple the internal body with the external one with assembling bolts. Refitting the pads and purging air (see previous sections).
- Place the calliper on the disc and lock it to the support by tightening the bolts.
- Lock the pipe joint to the calliper to the prescribed torque.

Upon fitting, the parts must be perfectly clean and **free of traces of oil, diesel fuel, grease, etc..** They should be washed thoroughly in denatured alcohol before proceeding.

**The sealing rings must be immersed in the operating liquid;** the use of the **PRF1** protection is tolerated.

#### CAUTION

**RUBBER PARTS SHOULD NEVER BE LEFT IN ALCOHOL FOR LONGER THAN 20 SECONDS. AFTER WASHING, THE PIECES MUST BE DRIED WITH A BLAST OF COMPRESSED AIR AND A CLEAN CLOTH.**

#### Locking torques (N\*m)

**Screw tightening calliper to the support 20 ÷ 25 Attachment to the calliper 25 ÷ 30 Nm**

- 1 DUST GUARDS
- 2 SEALING RINGS
- 3 PLUNGERS
- 4 O-RING GASKET

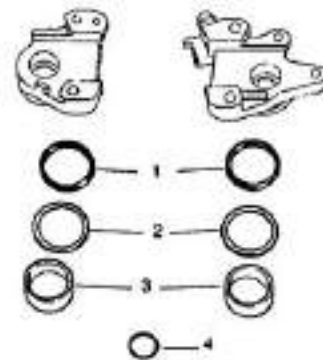

## Front brake disc

### Removal

- Should the brake disc be replaced, when refitting the hub, apply recommended product on the fixing bolts.

Tighten to the specified torque.

#### N.B.

**THE SURFACE OF THE DISC WITH THE STAMPED ARROW INDICATING THE DIRECTION OF ROTATION MUST FACE THE SHOCK ABSORBER.**

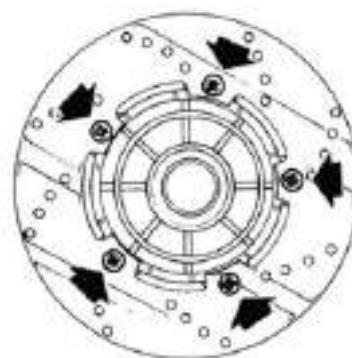

#### Recommended products

##### Loctite 242 product description

Apply LOCTITE medium type 242 threadlock

#### Locking torques (N\*m)

tightening torque  $5 \div 6.5$  Nm

## Disc Inspection

### Specific tooling

020335Y Magnetic support for dial gauge

### Characteristic

Max oscillation allowed

0.1 mm.

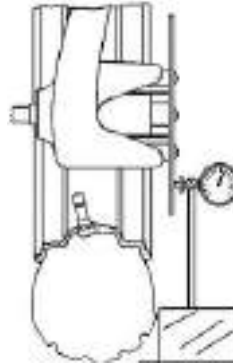

## Front brake pads

### Removal

- Pads must be replaced when the friction material thickness reaches the wear limit.

- To replace:

remove the protection cover, the bolt and the leaf spring. Slide off the pads and replace them once the plungers are down. Carry out these operations in reverse order to fit.



### CAUTION

**BEFORE USING THE BRAKE, OPERATE THE LEVER A FEW TIMES.**

### Front

-Once the bleed valve is closed, fill the system with brake liquid to the maximum level.

-Undo the bleed screw.

-Apply the tube of the special tool to the bleed screws.

When bleeding it is necessary to fill the oil tank in continuation while working with a MITYVAC pump on the bleed screws until no more air comes out of the system.

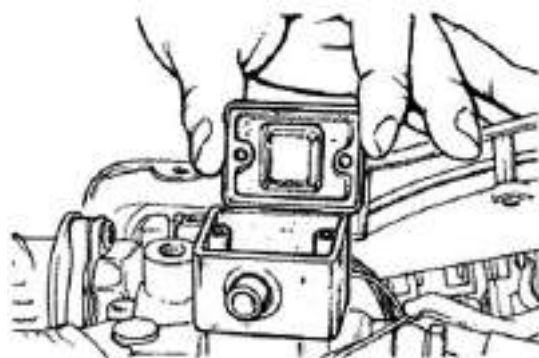

The operation is finished when just oil comes out of the bleed screws.

-Do up the bleed screw.

-When the operation is over, tighten up the oil bleed screw to the prescribed torque.

**N.B.**

IF AIR CONTINUES TO COME OUT DURING PURGING, EXAMINE ALL THE FITTINGS: IF SAID FITTINGS DO NOT SHOW SIGNS OF BEING FAULTY, LOOK FOR THE AIR INPUT AMONG THE VARIOUS SEALS ON THE PUMP AND CALLIPER PISTONS.

**CAUTION**

- DURING THE OPERATIONS, THE VEHICLE MUST BE ON THE STAND AND LEVEL.

**N.B.**

DURING PURGING FREQUENTLY CHECK THE LEVEL TO PREVENT AIR GETTING INTO THE SYSTEM THROUGH THE PUMP.

**WARNING**

- BRAKING CIRCUIT FLUID IS HYGROSCOPIC. IT ABSORBS HUMIDITY FROM THE SURROUNDING AIR. IF THE LEVEL OF HUMIDITY IN THE BRAKING FLUID EXCEEDS A GIVEN VALUE, BRAKING EFFICIENCY WILL BE REDUCED.

THEREFORE, ALWAYS USE FLUID FROM SEALED CONTAINERS.

UNDER NORMAL DRIVING AND CLIMATIC CONDITIONS YOU SHOULD CHANGE THIS LIQUID EVERY TWO YEARS. IF THE BRAKES ARE USED INTENSELY AND/OR IN HARSH CONDITIONS, CHANGE THE FLUID MORE FREQUENTLY.

**CAUTION**

WHEN CARRYING OUT THE OPERATION, BRAKE FLUID MAY LEAK FROM BETWEEN THE BLEED SCREW AND ITS SEAT ON THE CALLIPER.

CAREFULLY DRY THE CALLIPER AND DEGREASE THE DISC SHOULD THERE BE OIL ON IT.

### Specific tooling

020329Y Mity-Vac vacuum-operated pump

### Recommended products

AGIP BRAKE 4 Brake fluid

FMVSS DOT 4 Synthetic fluid

### Locking torques (N\*m)

Oil bleed screw 7 ÷ 10

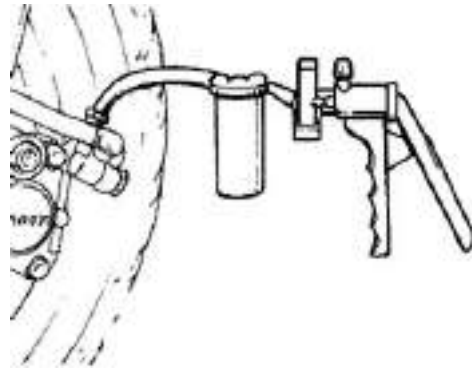

## Front brake pump

## Rear drum brake

---

Once the muffler and the wheel have been removed, follow these steps:

1. Remove the shoe spring using the specific spanner.
2. Remove the shoe with the aid of a lever.
3. Refit the new shoes giving a few taps with the mallet.
4. Attach the spring using the specific pliers.

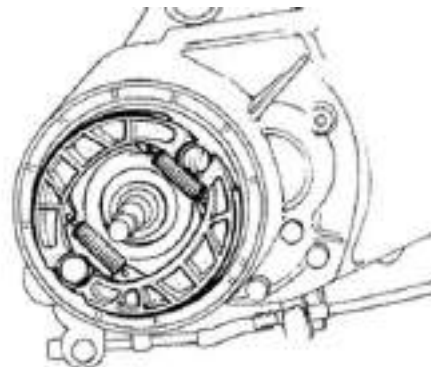

### Specific tooling

**020325Y Pliers for brake-shoe springs**

---



## INDEX OF TOPICS

CHASSIS

CHAS

---

## Rear handlebar cover

---

Undo the screws as shown in the figure and remove the handlebar rear section.



---

## Instrument panel

---

Operate the 4 screws shown in the figure to replace the instrument panel.

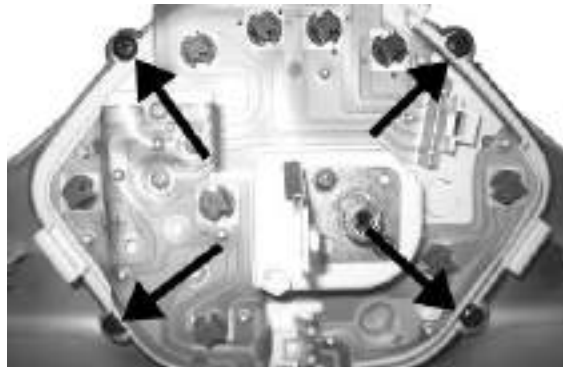

---

## Front handlebar cover

---

- Remove the 2 screws in the rear handlebar cover and the screw under the headlamp.
- Pull up and detach the front handlebar cover, disconnect the headlight assembly connections.





### Headlight assy.

After removing the front handlebar cover, operate the 4 screws shown in the figure and remove the headlight.



### Knee-guard

- Unscrew the 2 screws shown in the figure placed under the front grille.
- Remove the 3 screws shown in the figure, placed inside the glove-box; they can be reached after opening the glove-box door.

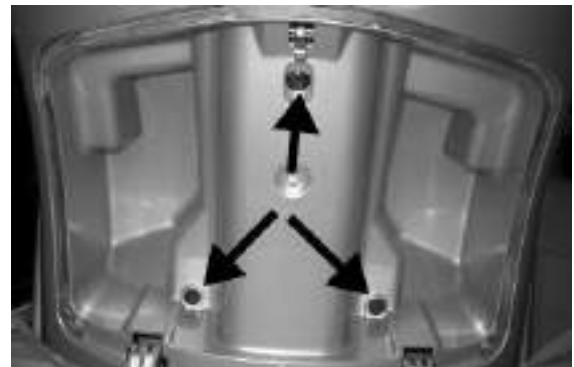
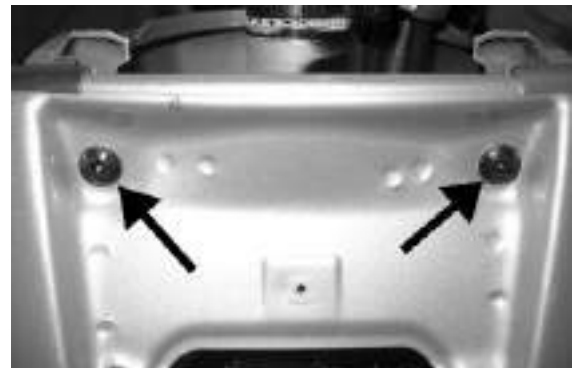

---

## Footrest

- Operate on the 3 screws shown in the figure once the glove-box and fairing have been removed.

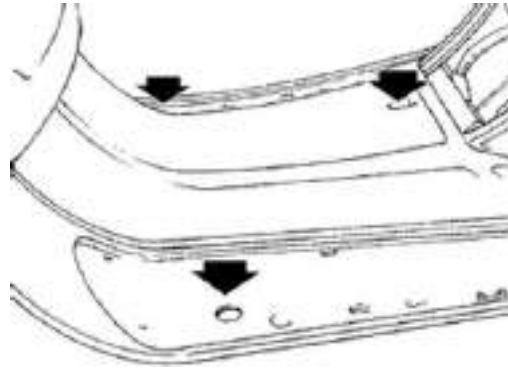

---

## Air filter

- Remove the helmet compartment.
- after removing the side fairing, remove the 2 screws fixing the filter box to the engine, indicated in the figure.
- Remove the two clamps indicated in the figure



---

## Front mudguard

- First remove the steering tube and uncouple the front brake pipes from the calliper in order to remove the front mudguard
- Remove the three mudguard-steering tube clamps indicated in the figure



---

## Front central cover

- Remove the "PIAGGIO" clip-on badge
- Unscrew the screw indicated in the figure
- Remove the grille



# INDEX OF TOPICS

**P**RE-DELIVERY

**P**RE DE

---

## **Aesthetic inspection**

**Appearance check:**

- Paintwork
- Fitting of plastics
- Scratches
- Dirt

---

## **Tightening torques inspection**

**Lock check**

- Safety locks
- clamping screws

**Safety locks**

---

Rear shock absorber upper fixing

---

Rear shock absorber lower fixing

---

Front wheel axle nut

---

Wheel hub nut

---

Frame - swinging arm bolt \*

---

Swinging arm bolt - Engine

---

Engine arm pin - Frame arm

---

Handlebar lock nut

---

Steering lower ring nut

---

Upper steering ring nut

---

## **Electrical system**

## Electrical system:

- Main switch
- Headlamps: high-beam lights, low-beam lights, tail and parking lights and their warning lights
- Adjusting the headlights according to the regulations currently in force
- Rear light, parking light, stop light
- Front and rear stop light switches
- Turn indicators and their warning lights
- Instrument panel lights
- Instrument panel: fuel gauge
- Instrument panel warning lights
- Horn
- Starter

**CAUTION**

**TO ENSURE MAXIMUM PERFORMANCE, THE BATTERY MUST BE CHARGED BEFORE USE. INADEQUATE CHARGING OF THE BATTERY WITH A LOW LEVEL OF ELECTROLYTE BEFORE IT IS FIRST USED SHORTENS THE LIFE OF THE BATTERY.**

**WARNING**

**BEFORE RECHARGING THE BATTERY, REMOVE THE CAPS OF EACH CELL. KEEP THE BATTERY AWAY FROM NAKED FLAMES OR SPARKS WHILE IT IS CHARGED. REMOVE THE BATTERY FROM THE SCOOTER, DISCONNECTING THE NEGATIVE TERMINAL FIRST.**

**CAUTION**

**WHEN INSTALLING THE BATTERY, ATTACH THE POSITIVE LEAD FIRST AND THEN THE NEGATIVE ONE.**

**WARNING**

**BATTERY ELECTROLYTE IS TOXIC AND IT MAY CAUSE SERIOUS BURNS. IT CONTAINS SULPHURIC ACID. AVOID CONTACT WITH YOUR EYES, SKIN AND CLOTHING.**

**IN CASE OF CONTACT WITH YOUR EYES OR SKIN, RINSE WITH ABUNDANT WATER FOR ABOUT 15 MINUTES AND SEEK IMMEDIATE MEDICAL ATTENTION.**

**IF IT ACCIDENTALLY SWALLOWED, IMMEDIATELY DRINK LARGE QUANTITIES OF WATER OR VEGETABLE OIL. SEEK IMMEDIATE MEDICAL ATTENTION.**

**BATTERIES PRODUCE EXPLOSIVE GASES; KEEP THEM AWAY FROM NAKED FLAMES, SPARKS AND CIGARETTES. IF THE BATTERY IS CHARGED IN A CLOSED PLACE, TAKE CARE TO ENSURE ADEQUATE VENTILATION. ALWAYS PROTECT YOUR EYES WHEN WORKING CLOSE TO BATTERIES.**

**KEEP OUT OF THE REACH OF CHILDREN**

**CAUTION**

**NEVER USE FUSES WITH A CAPACITY HIGHER THAN THAT RECOMMENDED. USING A FUSE OF UNSUITABLE RATING MAY SERIOUSLY DAMAGE THE VEHICLE OR EVEN CAUSE A FIRE.**

---

## Levels check

Level check:

- Hydraulic braking system fluid level.
- Rear hub oil level
- Engine coolant level.

---

## Road test

**Test ride**

- Cold start
- Instrument operations
- Response to the throttle control
- Stability on acceleration and braking
- Rear and front brake efficiency
- Rear and front suspension efficiency
- Abnormal noise

---

## Static test

Static control after the test ride:



- Starting when warm
- Starter operation
- Minimum hold (turning the handlebar)
- Uniform turning of the steering
- Possible leaks

**CAUTION**

**CHECK AND ADJUST TYRE PRESSURE WITH TYRES AT AMBIENT TEMPERATURE.**

**CAUTION**

**NEVER EXCEED THE RECOMMENDED INFLATION PRESSURES OR TYRES MAY BURST.**

---

## Functional inspection

Functional check up:

Braking system (hydraulic)

- Lever travel

Braking system (mechanical)

- Lever travel

Clutch

- Proper functioning check

Engine

- Throttle travel check

Others

- Check documentation
  - Check the frame and engine numbers
  - Tool kit
  - License plate fitting
  - Check locks
  - Check tyre pressures
  - Installation of mirrors and any accessories
-

# INDEX OF TOPICS

TIME

TIME

This section is devoted to the time necessary to carry out repairs.



The description and code for each operation is indicated.

## Engine

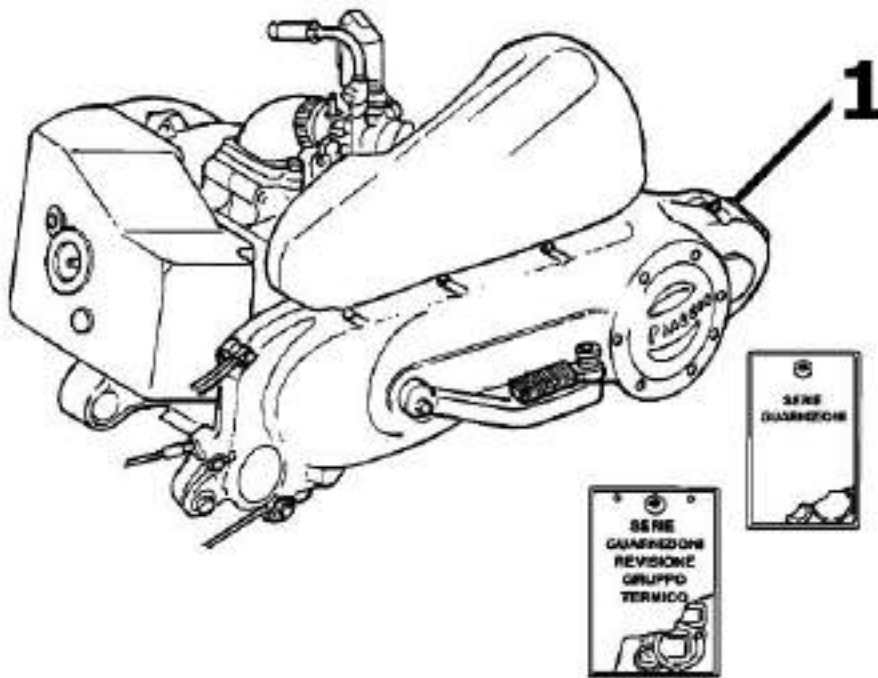

### ENGINE

	Code	Action	Duration
1	001001	engine from frame - removal and re-fitting	

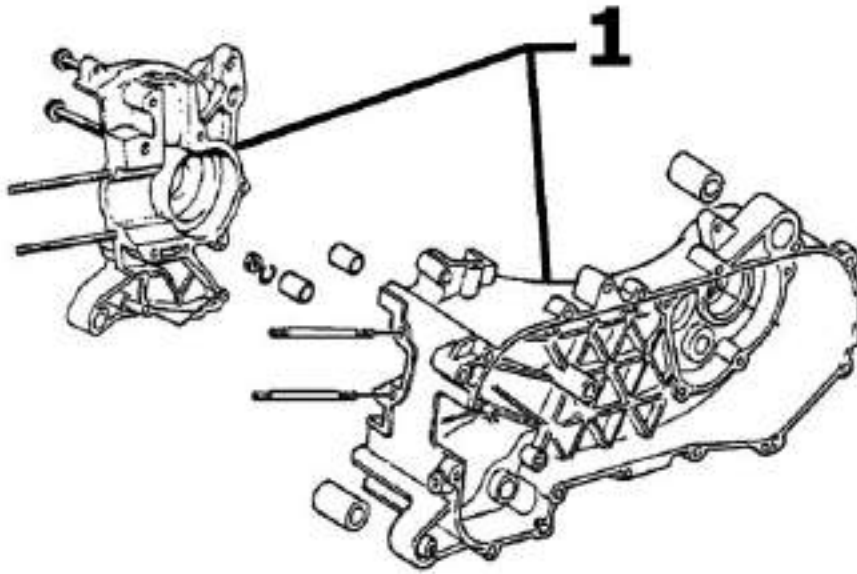
**Crankcase****CRANKCASE**

	<b>Code</b>	<b>Action</b>	<b>Duration</b>
1	001133	Engine crankcase - Replacement	

**Crankshaft**

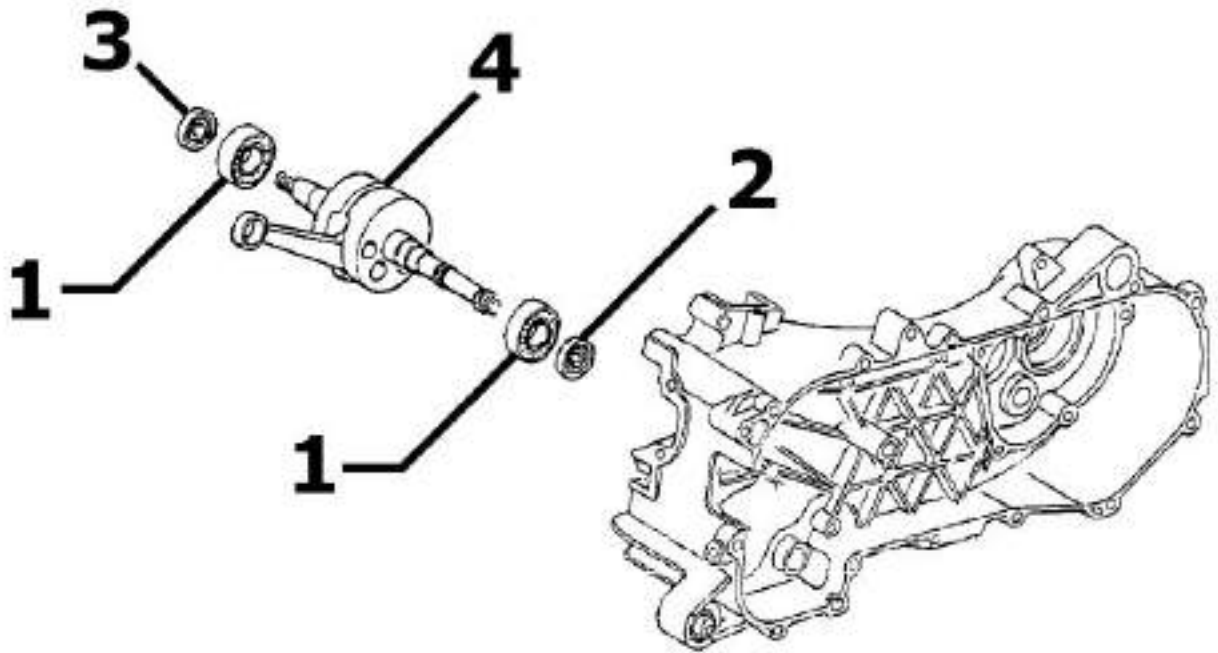

**CRANKSHAFT**

	<b>Code</b>	<b>Action</b>	<b>Duration</b>
1	001118	Main bearings - Replacement	
2	001100	Clutch-side oil seal - Replacement	
3	001099	Oil seal, flywheel side - Replacement	
4	001117	Crankshaft - Replacement	

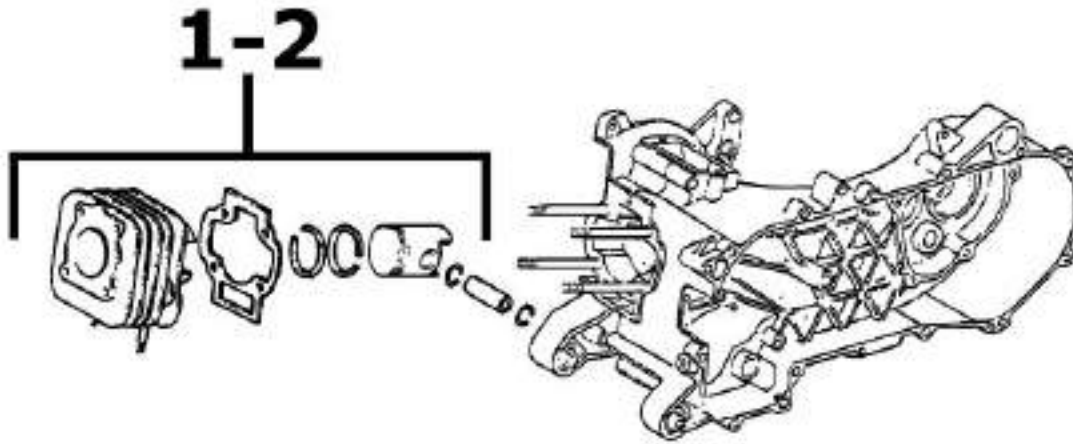
**Cylinder assy.****CYLINDER- PISTON**

	<b>Code</b>	<b>Action</b>	<b>Duration</b>
1	001002	Cylinder-Piston - Replacement	
2	001107	Cylinder / piston - Inspection / cleaning	

Cylinder head assy.

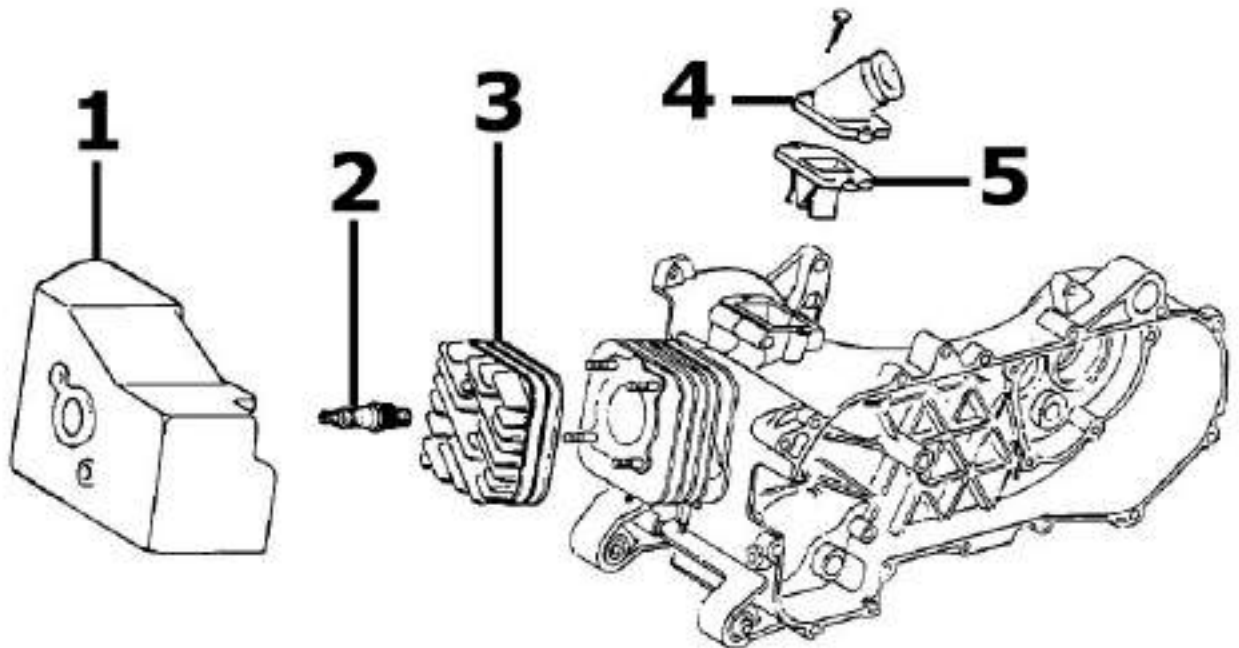

**HEAD**

	Code	Action	Duration
1	001097	Cooling hood - Replacement	
2	001093	Spark plug - Replacement	
3	001126	Head - Replacement	
4	001013	Intake manifold - Replacement	
5	001178	Disc pack - Replacement	

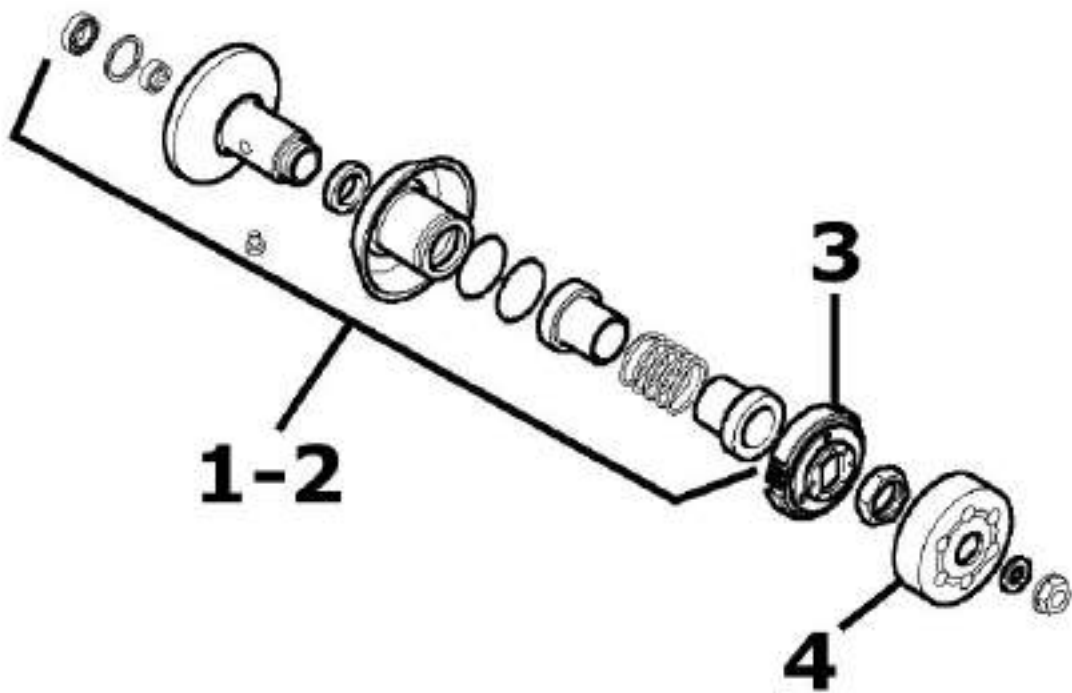
**Driven pulley****DRIVEN PULLEY - CLUTCH**

	<b>Code</b>	<b>Action</b>	<b>Duration</b>
1	001012	Driven pulley - overhaul	
2	001110	Driven pulley- Replacement	
3	001022	Clutch - Replacement	
4	001155	Clutch bell housing - Replacement	



Oil pump

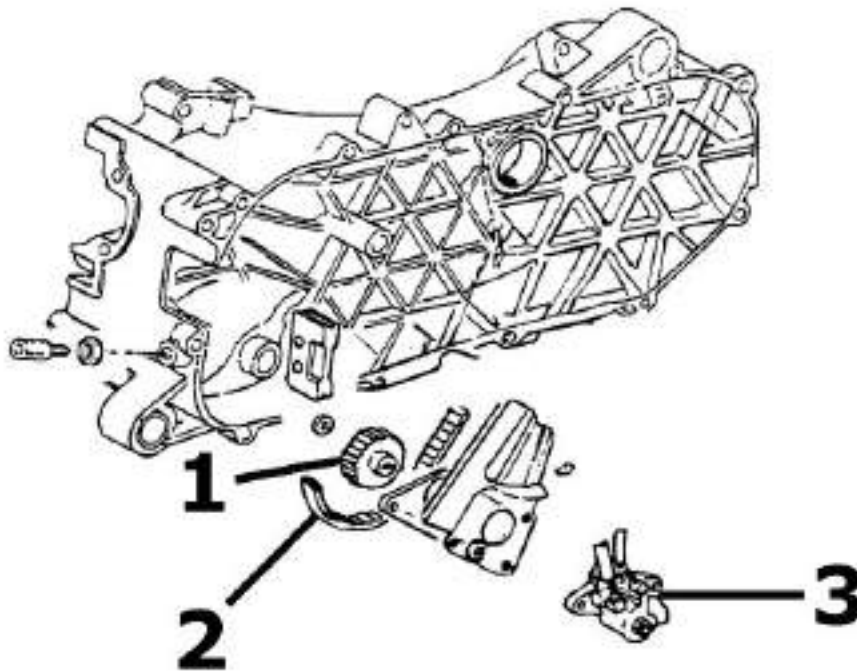

**OIL PUMP**

	<b>Code</b>	<b>Action</b>	<b>Duration</b>
1	001028	Mix movement gear socket - Replacement	
2	001019	Mixer belt - replacement	
3	001018	Mixer - Replacement	

## Final gear assy.

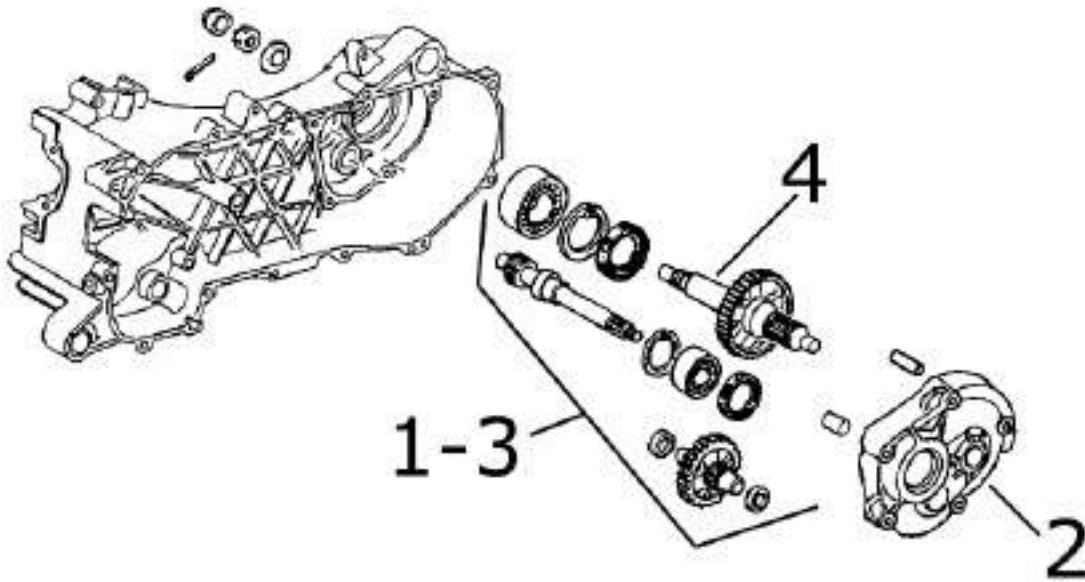

### FINAL REDUCTION GEAR

	Code	Action	Duration
1	001010	Geared reduction unit - Service	
2	001156	Gear reduction unit cover - Replacement	
3	003065	Gear box oil - Replacement	
4	004125	Rear wheel axle - Replacement	

Driving pulley

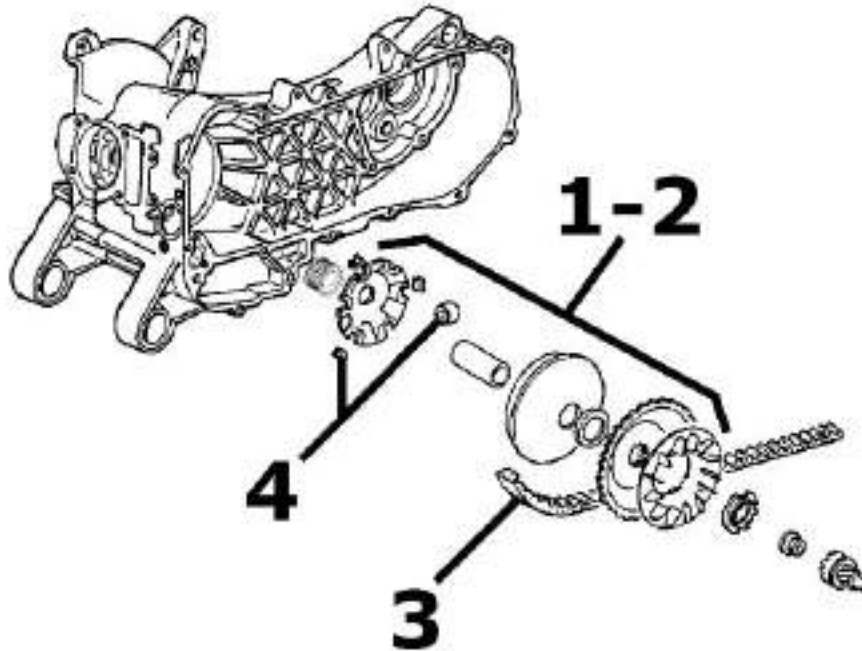

**DRIVING PULLEY**

	<b>Code</b>	<b>Action</b>	<b>Duration</b>
1	001066	Driving pulley - Removal and refitting	
2	001086	Driving half-pulley - replace	
3	001011	Driving belt - Replacement	
4	001177	Variator rollers / shoes - Replacement	

## Transmission cover

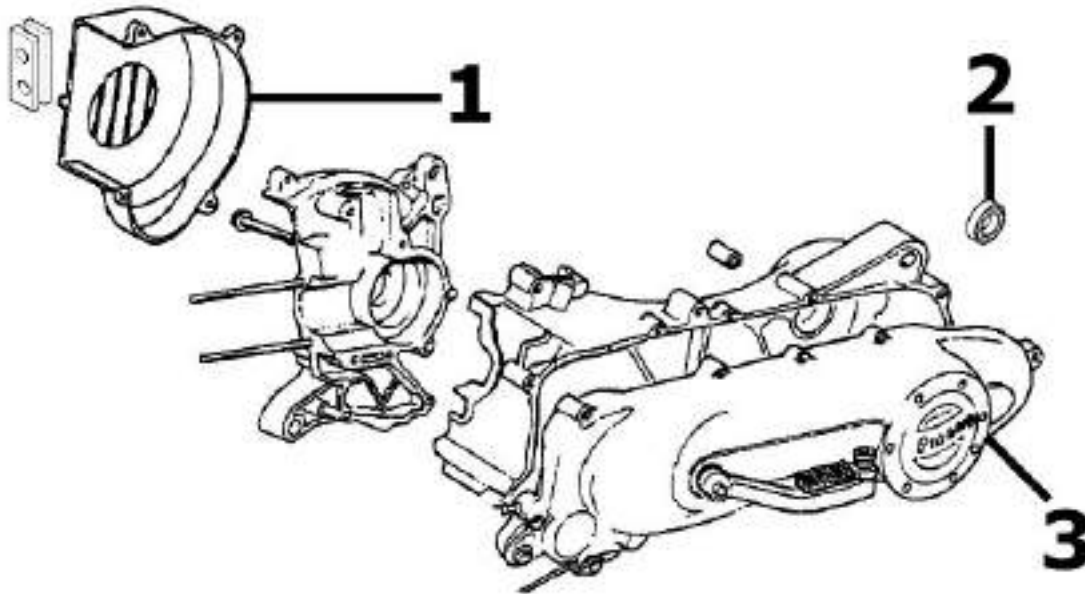
**TRANSMISSION COVER**

	<b>Code</b>	<b>Action</b>	<b>Duration</b>
1	001087	Flywheel cover - Replacement	
2	001135	Transmission cover bearing - Replacement	
3	001096	Transmission crankcase cover - Replacement	

**Starter motor**

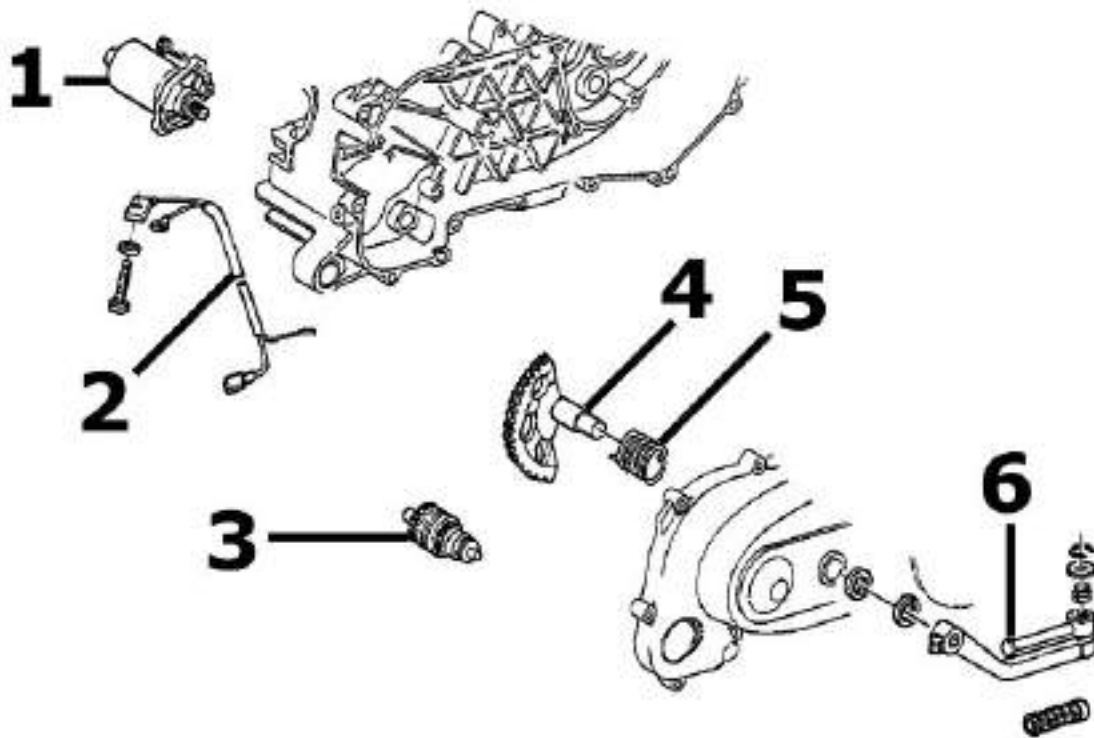

**ELECTRICAL START-UP**

	<b>Code</b>	<b>Action</b>	<b>Duration</b>
1	001020	Starter motor - Replacement	
2	005045	Starter motor cable harness - Replacement	
3	001017	Starter sprocket wheel - Replacement	
4	001021	Kick starter - Inspection	
5	008008	Starter spring pack - Replacement	
6	001084	Starter lever - Replacement	

## Flywheel magneto

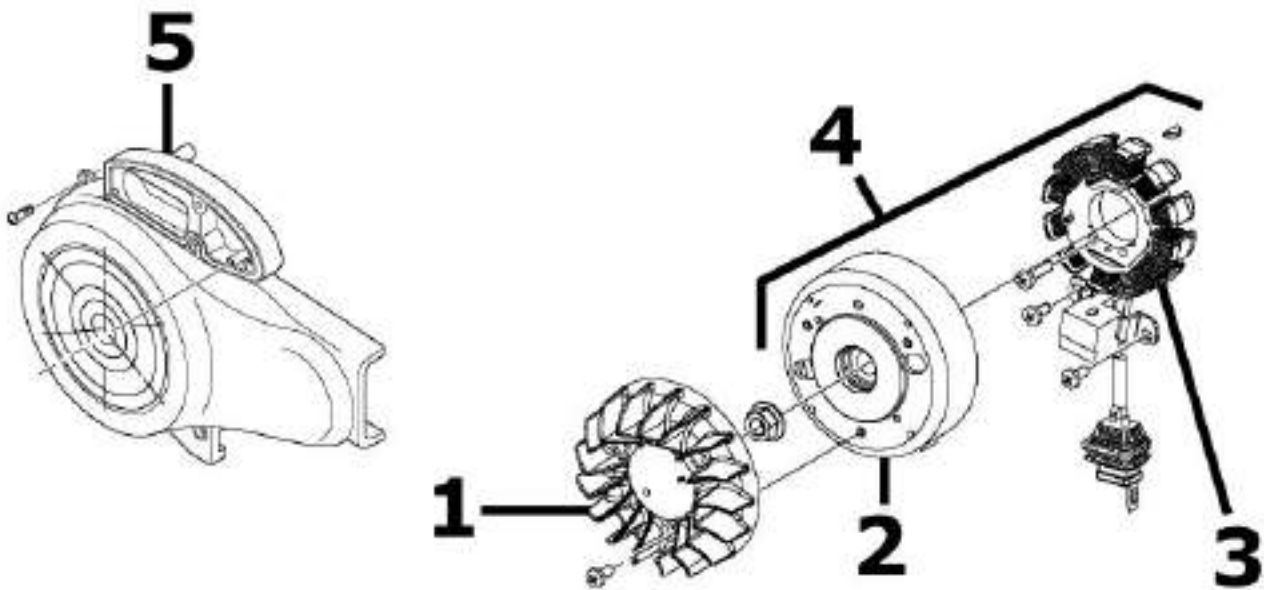

### MAGNETO FLYWHEEL

	Code	Action	Duration
1	001109	Cooling fan - Replacement	
2	001173	Rotor - Replacement	
3	001067	Stator - Fitting and Refitting	
4	001058	Flywheel - Replacement	
5	001087	Flywheel cover - Replacement	

**Carburettor**

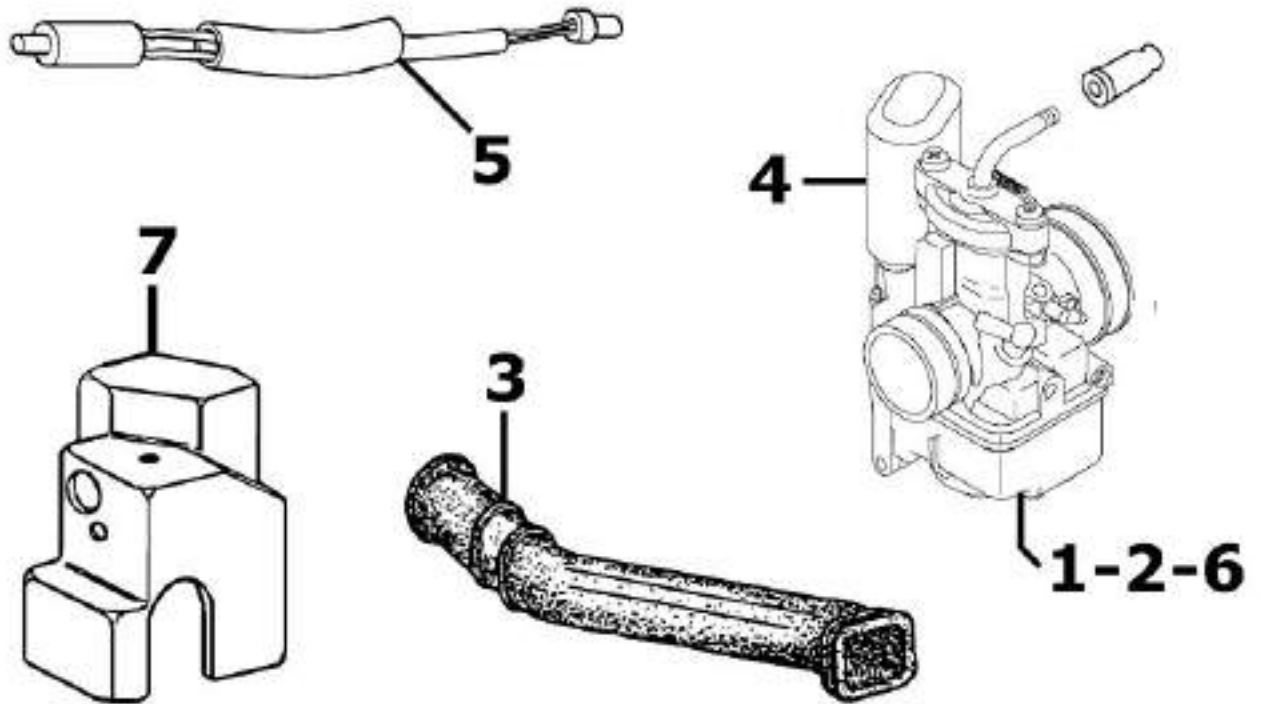

**CARBURETTOR**

	<b>Code</b>	<b>Action</b>	<b>Duration</b>
1	001008	Carburettor - Inspection	
2	001063	Carburettor - Replacement	
3	007020	Carburettor heating tubing - replacement	
4	001081	Automatic choke - Replacement	
5	001082	Carburettor heating resistor - Replacement	
6	003058	Carburettor - Adjustment	
7	004177	Heating hood - Replacement	

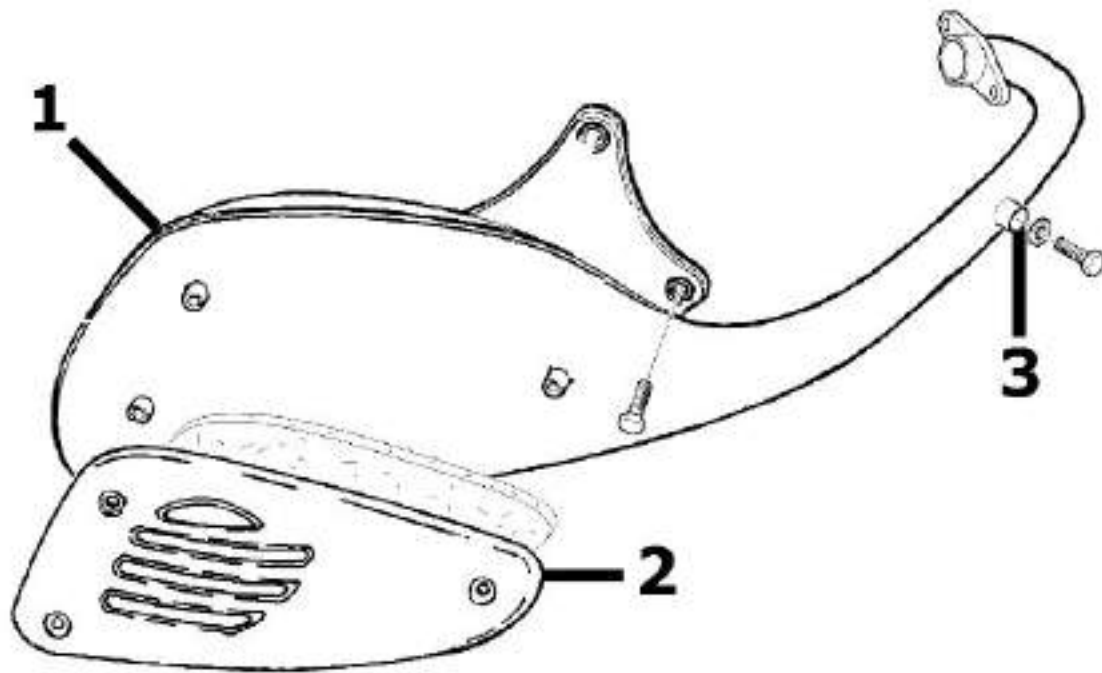
**Exhaust pipe****MUFFLER**

	<b>Code</b>	<b>Action</b>	<b>Duration</b>
1	001009	Muffler - Replacement	
2	001095	Muffler guard - Replacement	
3	001136	Exhaust emissions - Adjustment	



**Air cleaner**

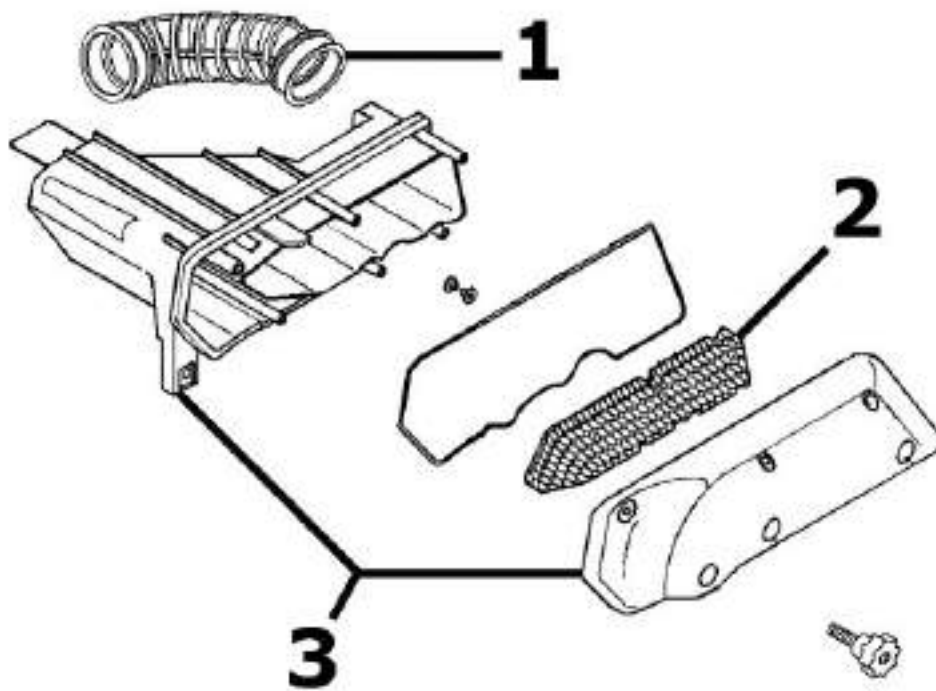

**AIR CLEANER**

	<b>Code</b>	<b>Action</b>	<b>Duration</b>
1	004122	Air cleaner carburettor fitting - Replacement	
2	001014	Air filter - Replacement / cleaning	
3	001015	Air filter box - Replacement	

## Frame

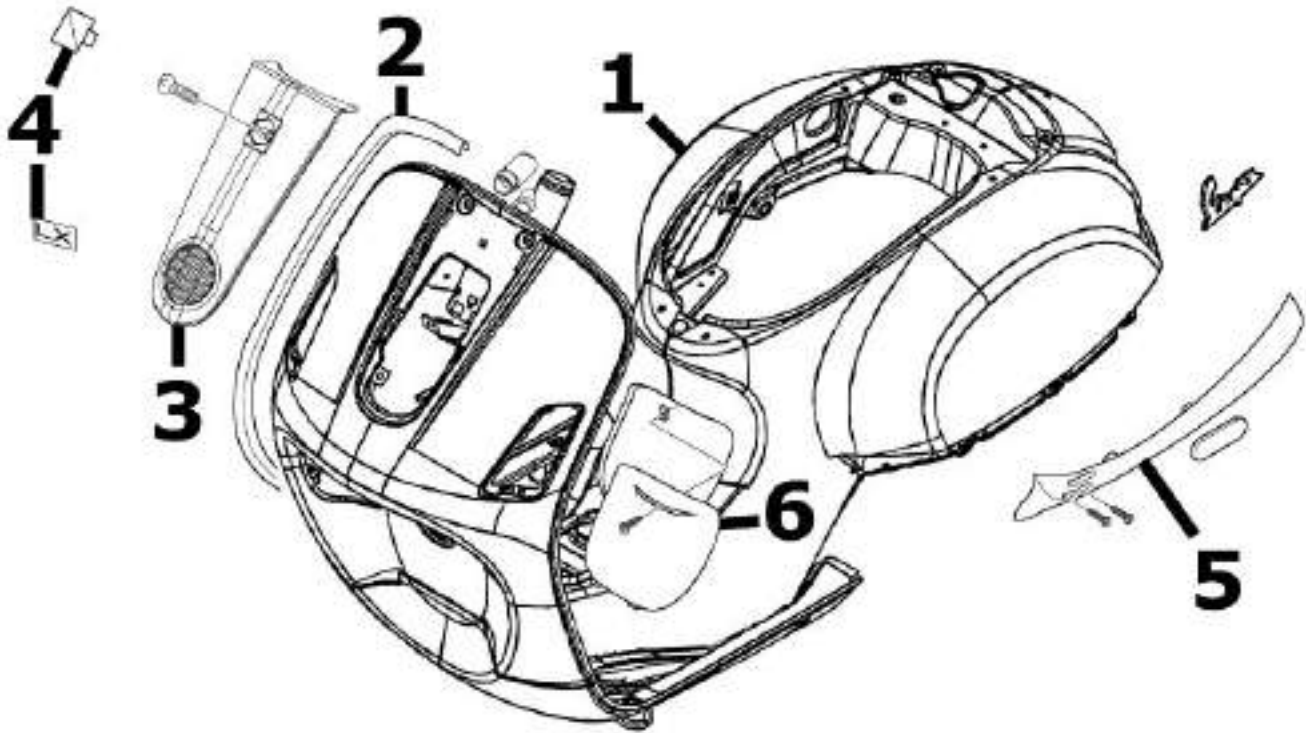
**FRAME**

	Code	Action	Duration
1	004001	Frame - Replacement	
2	004023	Shield rim - Replacement	
3	004149	Shield central cover - Replacement	
4	004159	Plates / Stickers - Replacement	
5	004012	Rear side panels - Replacement	
6	004059	Spark plug inspection flap - Replacement	

Centre-stand

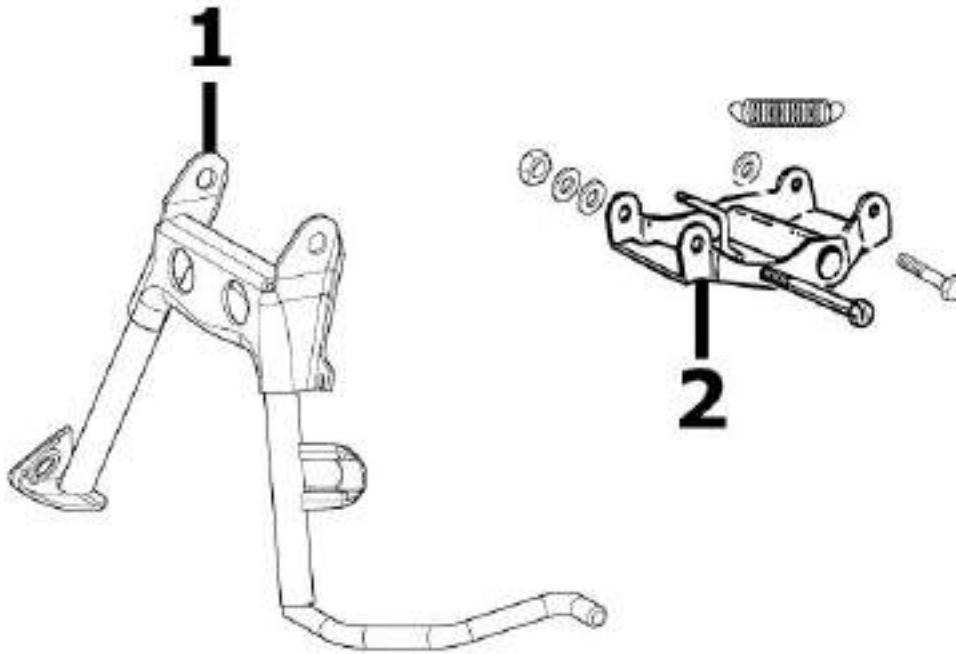

**STAND**

	<b>Code</b>	<b>Action</b>	<b>Duration</b>
1	004004	Stand - Replacement	
2	004171	Stand support plate - Replacement	

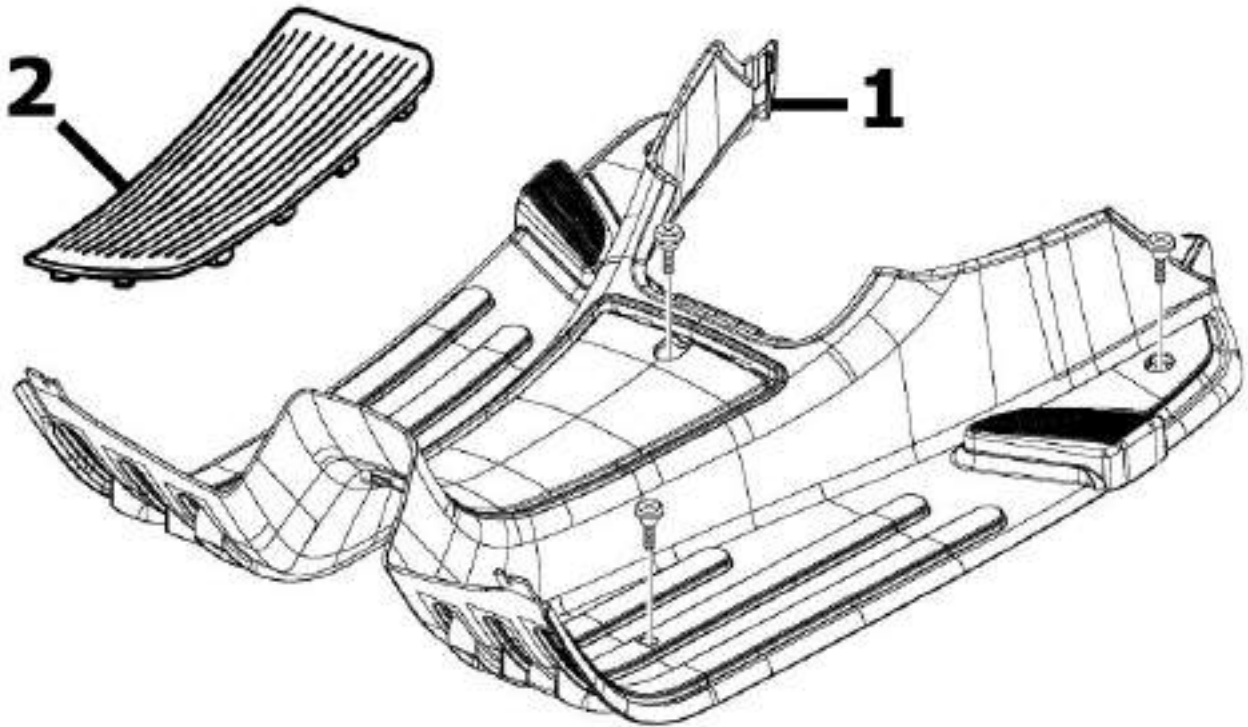
**Footrests****FOOTREST**

	<b>Code</b>	<b>Action</b>	<b>Duration</b>
1	004178	Footrest - Replacement	
2	004078	Front/rear footrest rubber - Replacement	

Rear cover

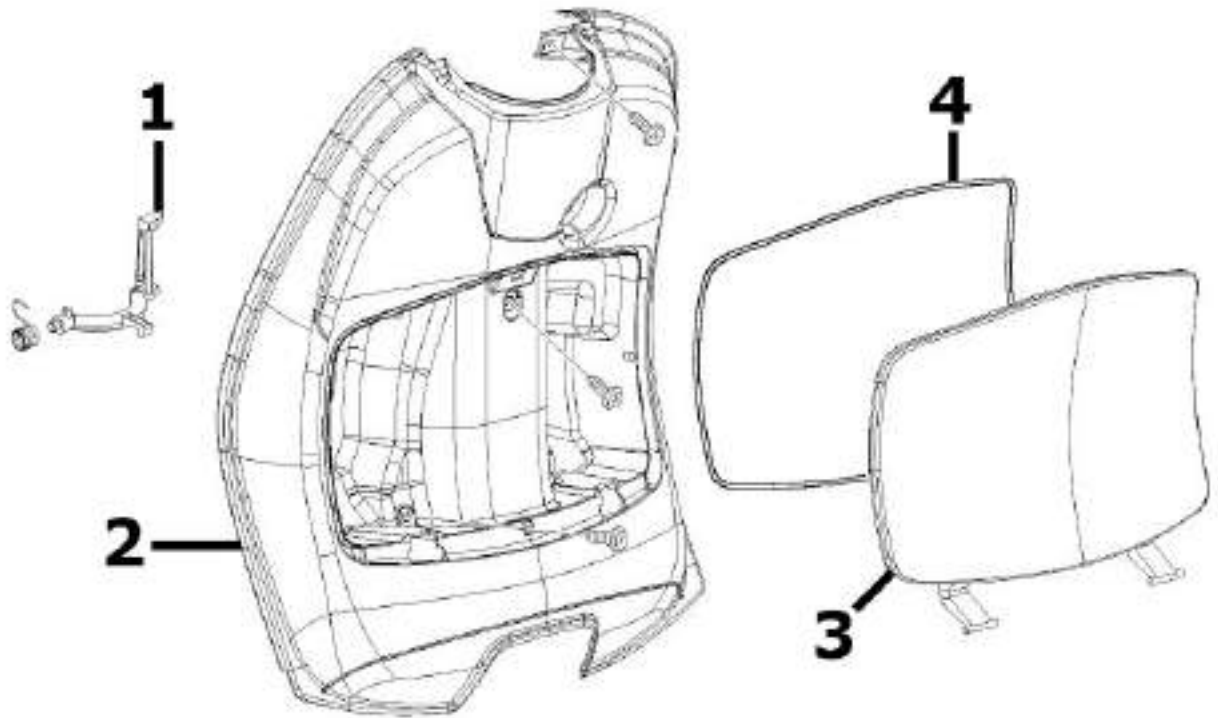

**SHIELD BACK PLATE**

	Code	Action	Duration
1	004174	Trunk levers - Replacement	
2	004065	Legshield, rear part - Removal and refitting	
3	004081	Glove box door - Replacement	
4	004082	Top box gasket - Replacement	

## Underseat compartment

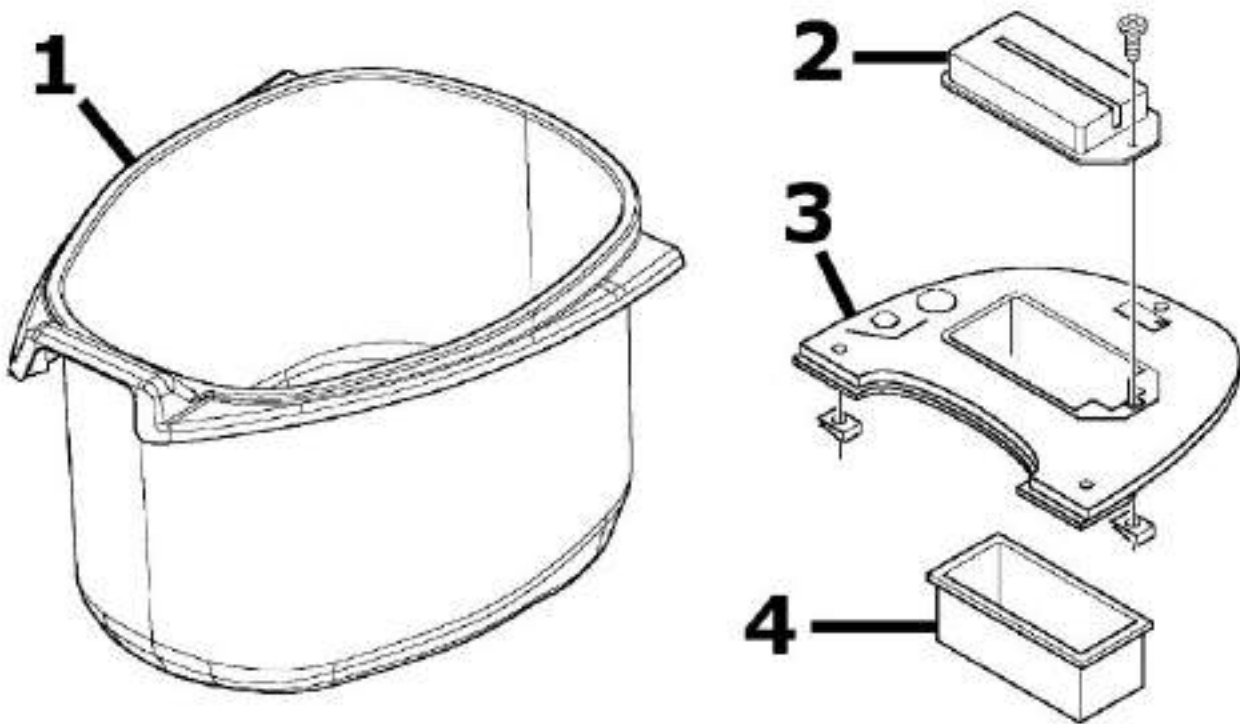

### HELMET COMPARTMENT

	Code	Action	Duration
1	004016	Helmet compartment - Replacement	
2	005046	Battery cover - change	
3	004011	Central frame cover - Replacement	
4	004071	Battery compartment - replacement	

Plate holder

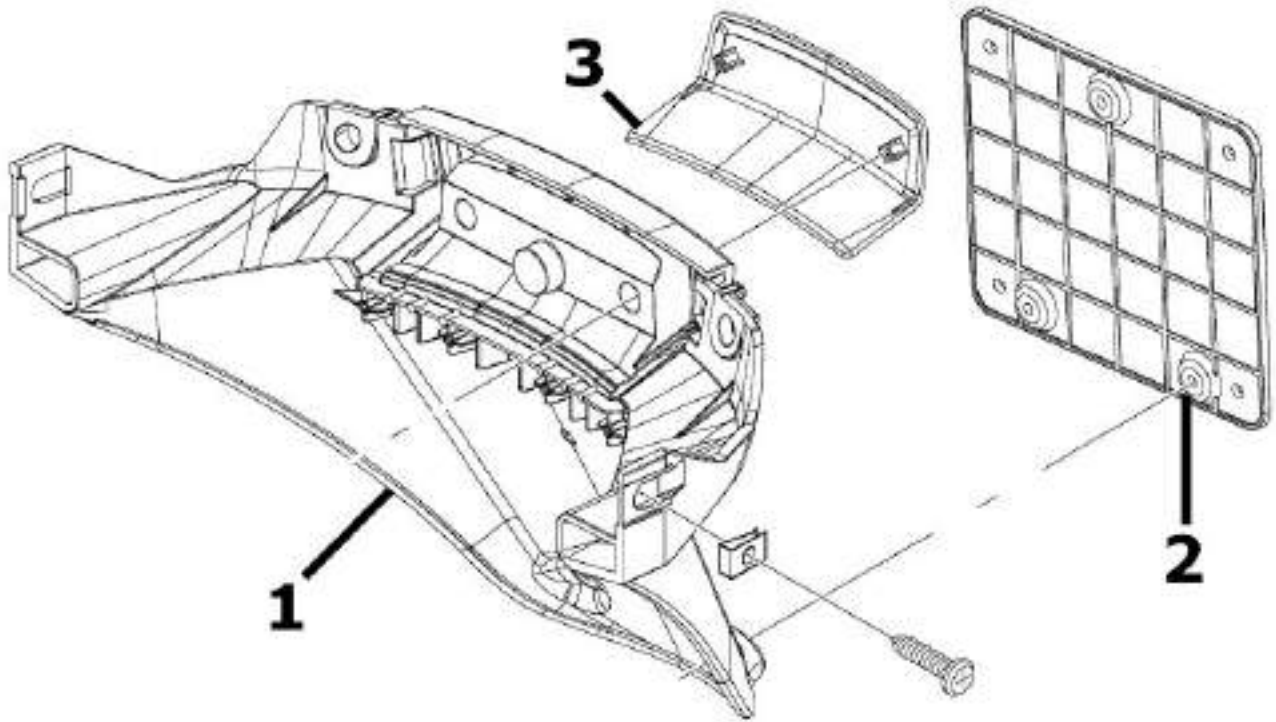

LICENSE PLATE HOLDER

	Code	Action	Duration
1	004136	License plate holder support - Replacement	
2	005048	Licence plate holder - Replacement	
3	005032	number plate light glass - Replacement	

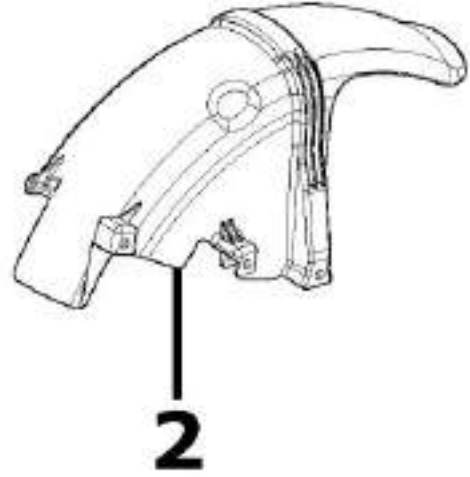
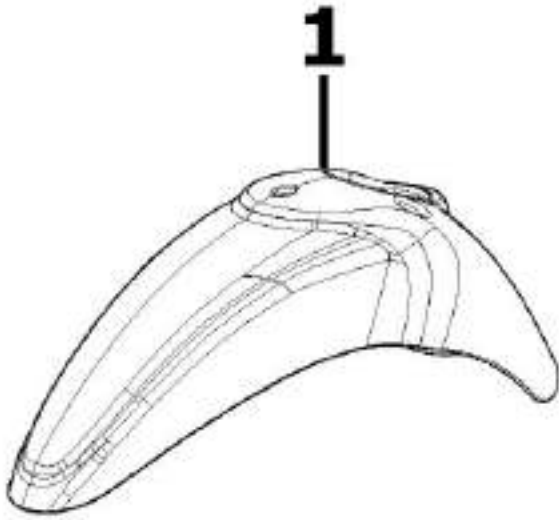
**Mudguard****MUDGUARDS**

	<b>Code</b>	<b>Action</b>	<b>Duration</b>
1	004002	Front mudguard - Replacement	
2	004009	Rear mudguard - Replacement	



Fuel tank

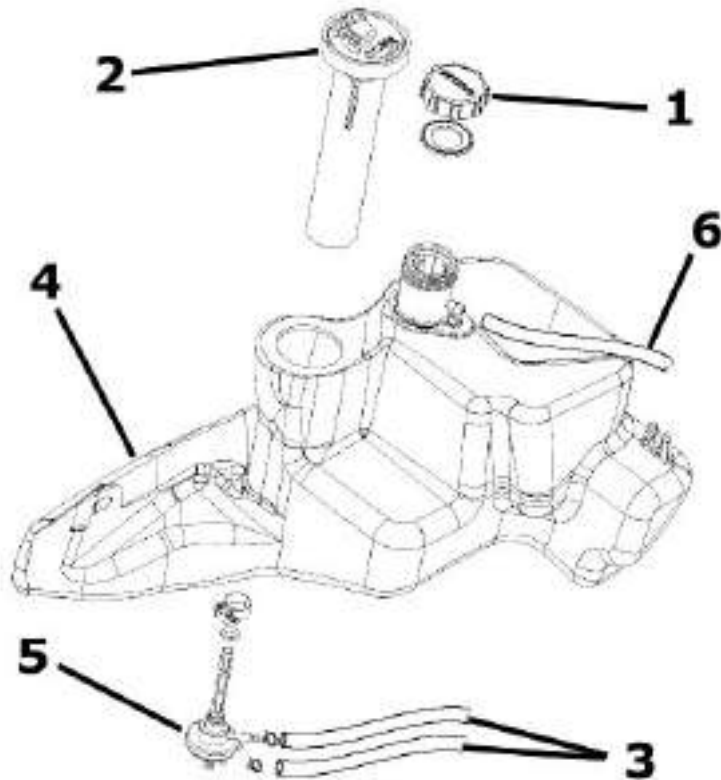

**FUEL TANK**

	Code	Action	Duration
1	004168	Fuel tank cap - Replacement	
2	005010	Tank float - Replacement	
3	004112	Cock-carburettor hose - Replacement	
4	004005	Fuel tank - Replacement	
5	004007	Fuel valve - Replacement	
6	004109	Fuel tank breather - change	

## Tank oil

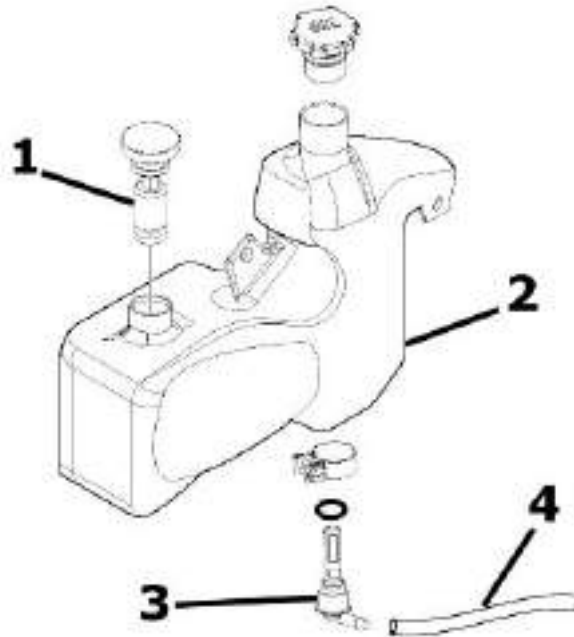

### OIL RESERVOIR

	Code	Action	Duration
1	005018	Oil reservoir float - Replacement	
2	004017	Oil reservoir - Replacement	
3	004095	Oil reservoir cock - Replacement	
4	004091	Oil reservoir hose - Replacement	

## Rear shock-absorber

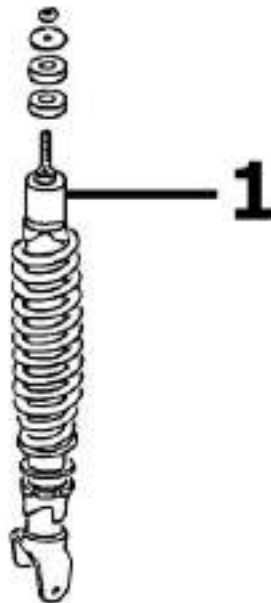

**REAR SHOCK ABSORBER**

	Code	Action	Duration
1	003007	Rear shock absorber - Removal and Refitting	

**Steering column bearings**

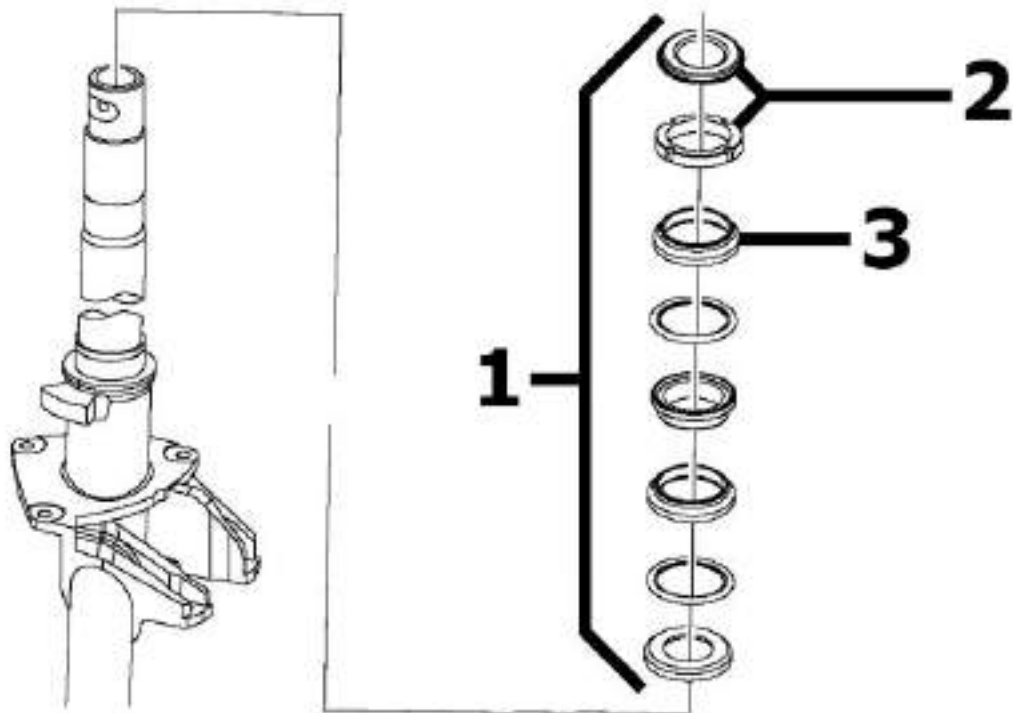

**STEERING FIFTH WHEELS**

	Code	Action	Duration
1	003002	Steering fifth wheels - Replacement	
2	003073	Steering clearance - Adjustment	
3	004119	Bearing / upper steering fifth wheel - Replacement	

## Handlebar covers

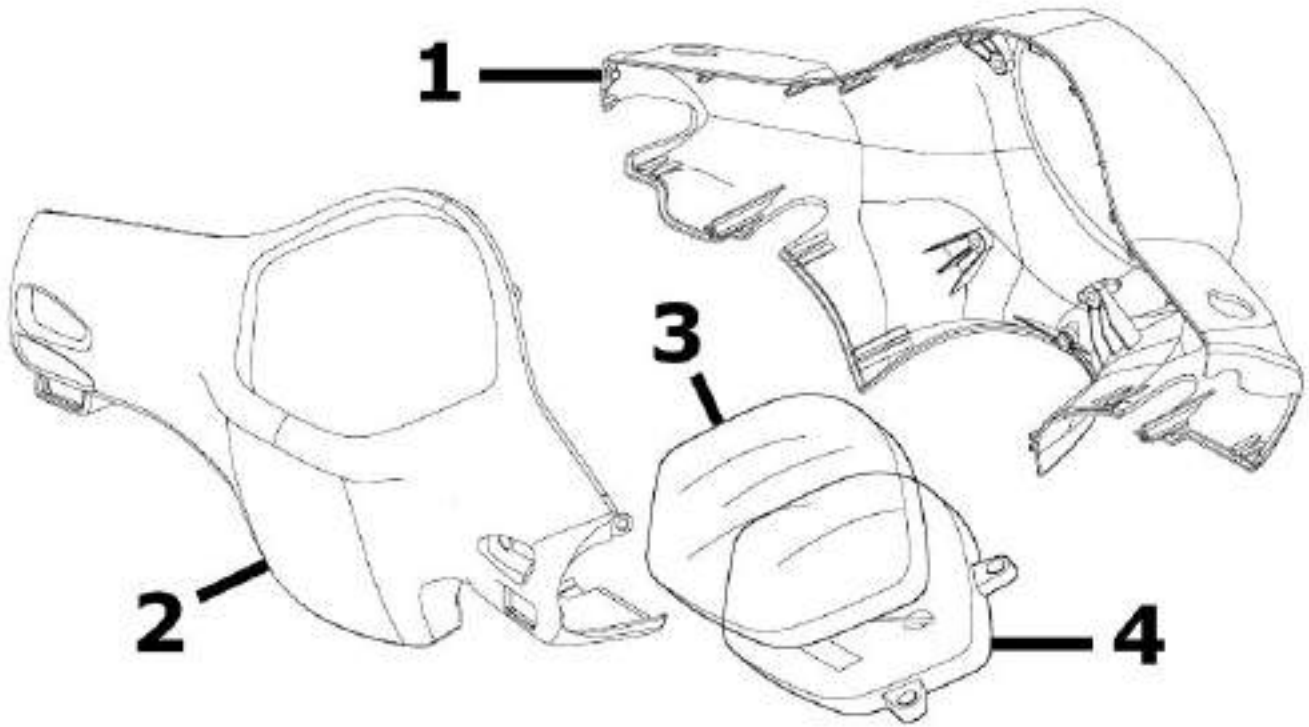

### TAVOLA COPRIMANUBRIO

	<b>Code</b>	<b>Action</b>	<b>Duration</b>
1	004018	Front handlebar covers - Replacement	
2	004019	Rear handlebar covers - Replacement	
3	005078	Odometer glass - Replacement	
4	005014	Instrument panel - Replacement	

Handlebar components

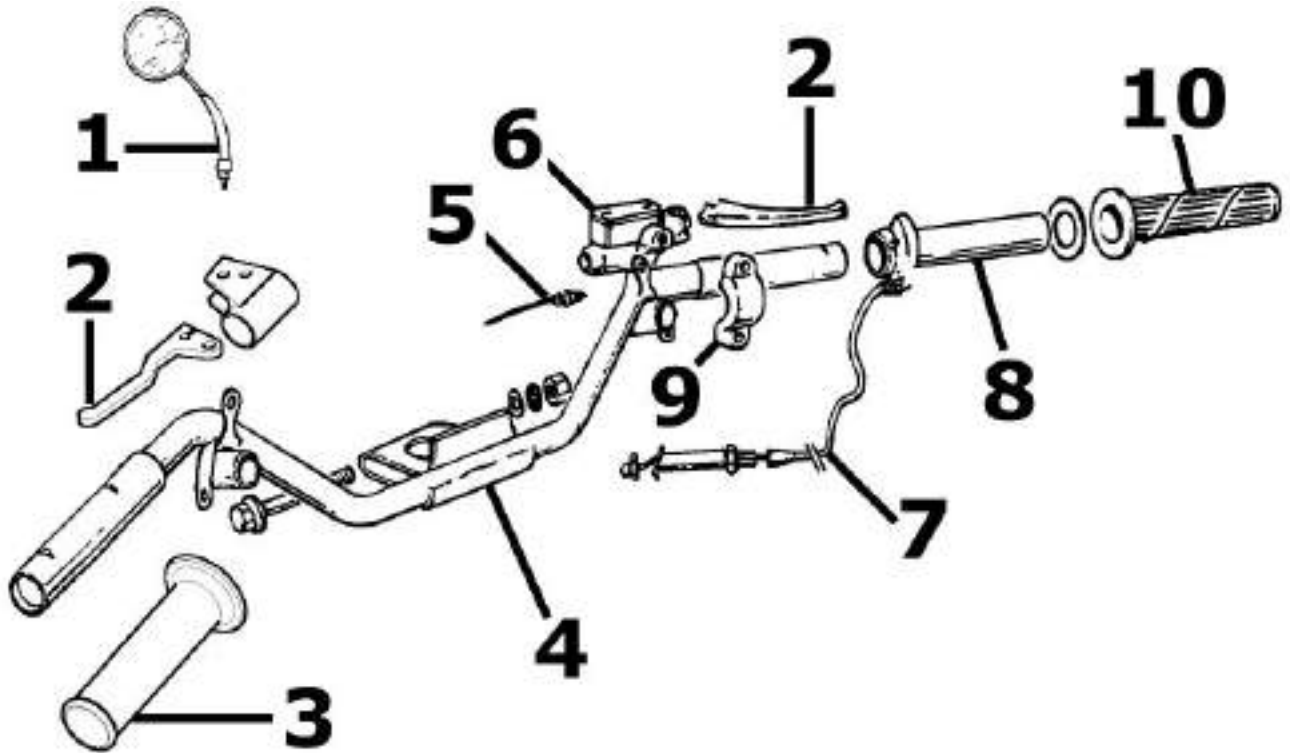

**HANDLEBAR COMPONENTS**

	Code	Action	Duration
1	004066	Driving mirror - Replacement	
2	002037	Brake or clutch lever - Replacement	
3	002071	Left hand grip - Replacement	
4	003001	Handlebar - Replacement	
5	005017	Stop switch - Replacement	
6	002024	Front brake pump - Removal and Re-fitting	
7	002054	Throttle or splitter transmission complete - Replacement	
8	002060	Complete throttle control - Replacement	
9	004162	Mirror support and/or brake pump fitting U-bolt - Replacement	
10	002059	Right hand grip - Replacement	

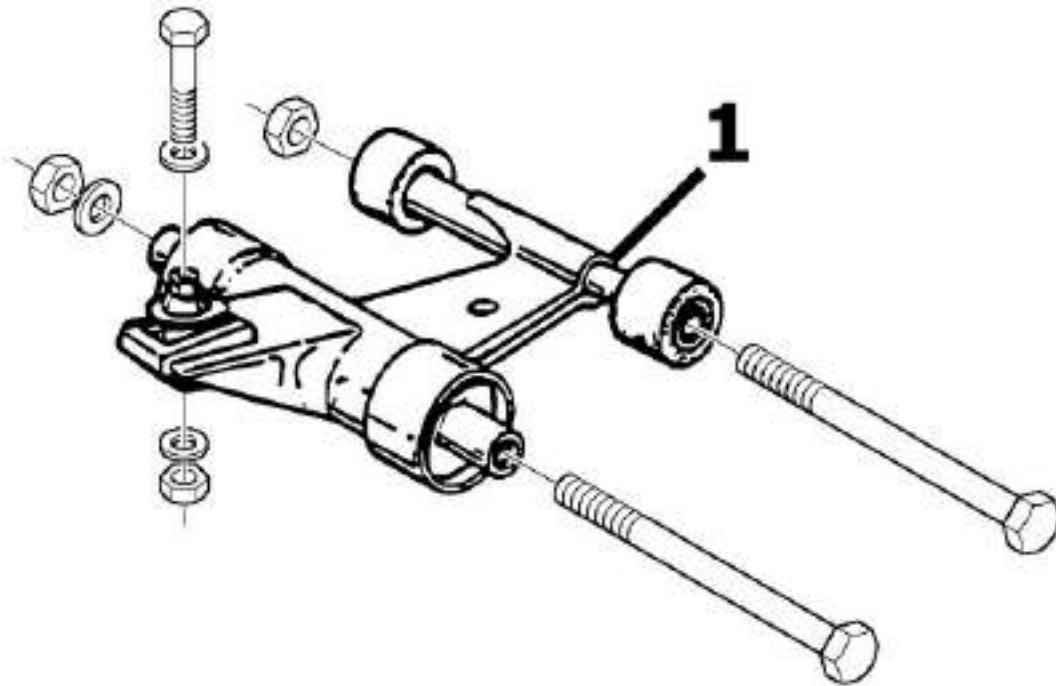
**Swing-arm****SWINGING ARM**

	<b>Code</b>	<b>Action</b>	<b>Duration</b>
1	001072	Engine-frame connection swinging arm - Replacement	

Seat

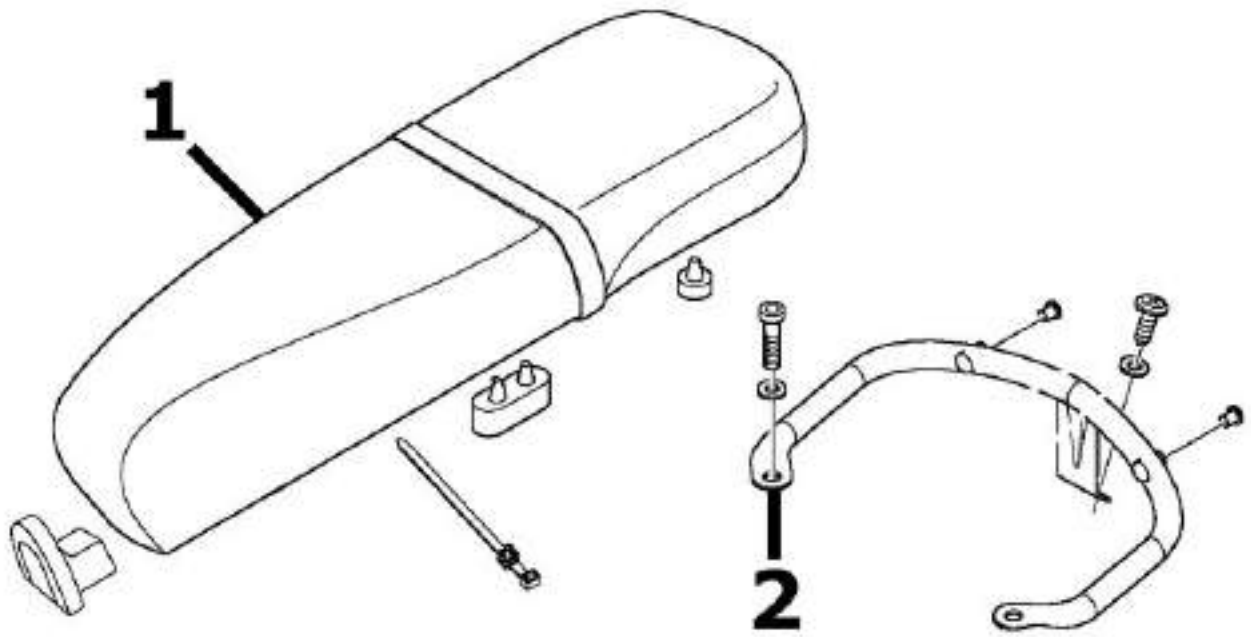

**SADDLE**

	Code	Action	Duration
1	004003	Saddle - Replacement	
2	004131	Luggage rack support - Replacement	

## Turn signal lights

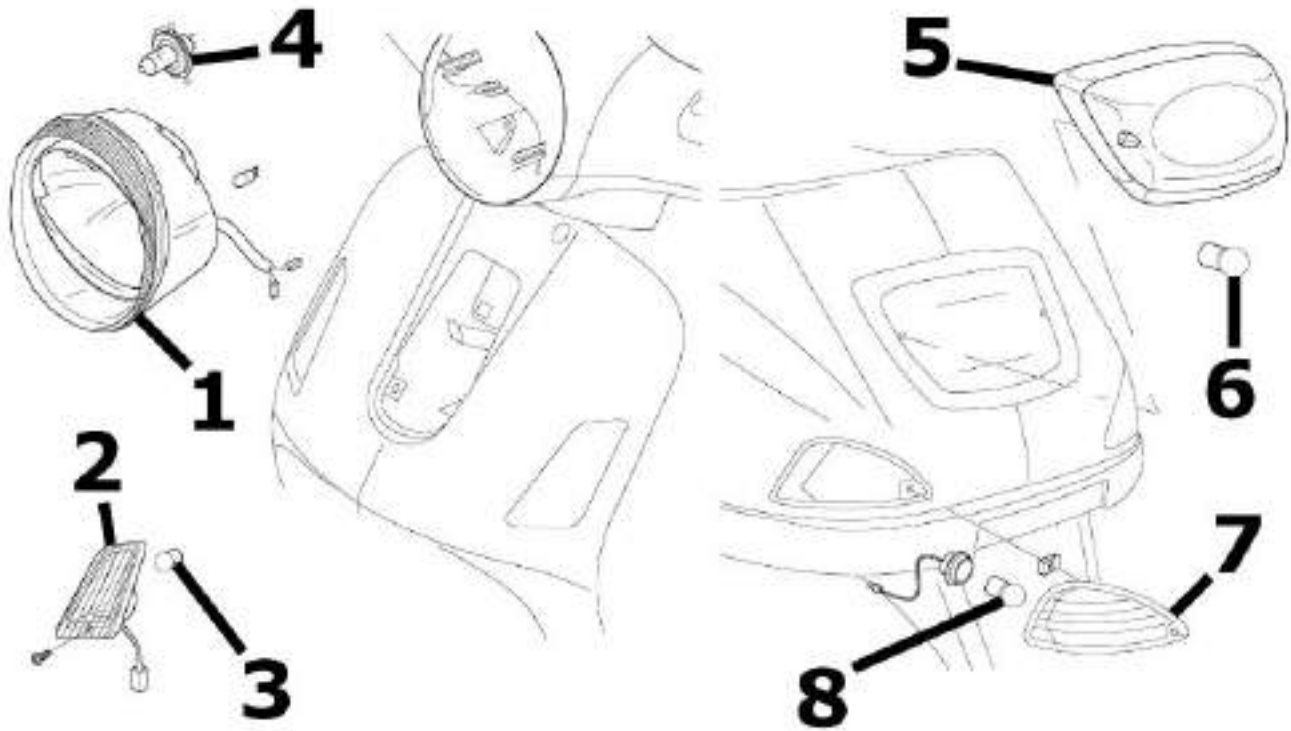
**TURN INDICATOR LIGHTS**

	<b>Code</b>	<b>Action</b>	<b>Duration</b>
1	005002	Front headlamp - change	
2	005012	Front turn indicator - Replacement	
3	005067	Front turn indicator bulb - Replacement	
4	005008	Headlight bulbs - Replacement	
5	005005	Taillight - change	
6	005066	Rear light bulbs - Replacement	
7	005022	Rear turning indicators - Replacement	
8	005068	Rear turning indicator bulb - Replacement	



Front wheel

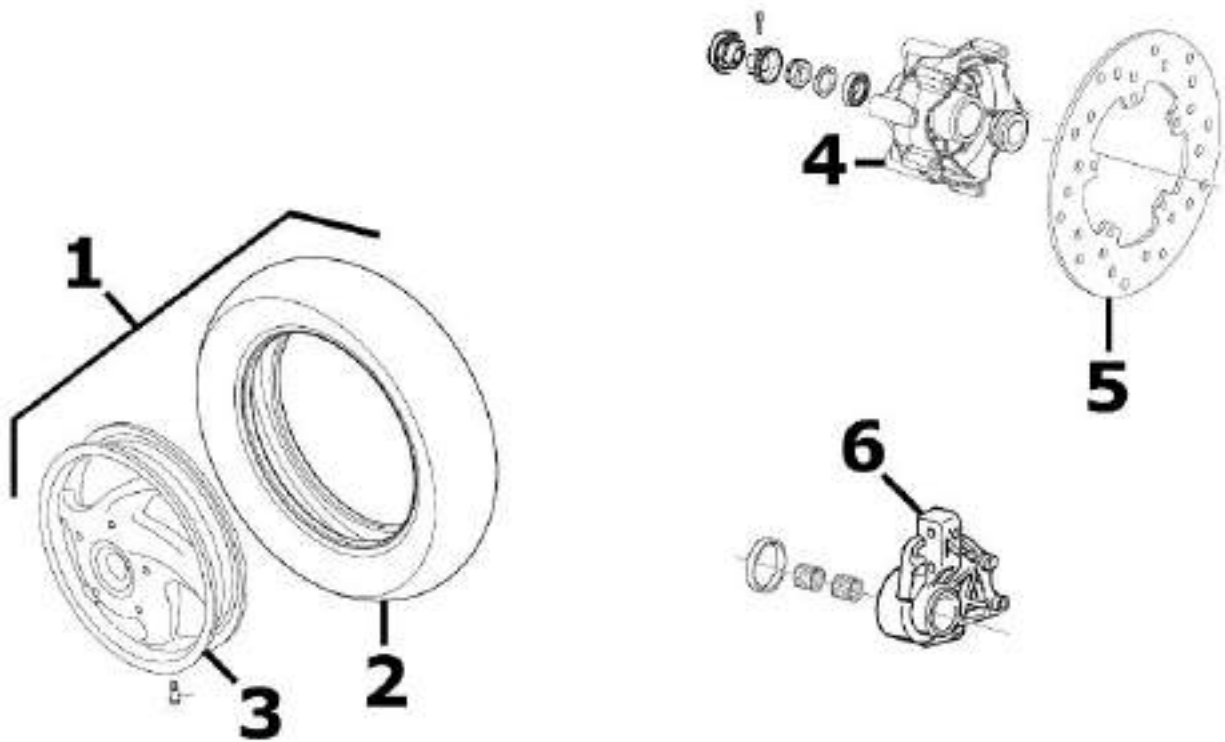

**FRONT WHEEL**

	Code	Action	Duration
1	004123	Front wheel - Replacement	
2	003047	Front tyre - Replacement	
3	003037	Front wheel rim - Replacement	
4	003033	Front wheel hub- Replacement	
5	002041	Front brake disc - Replacement	
6	003034	Front wheel hub bearing - Replacement	

Rear wheel

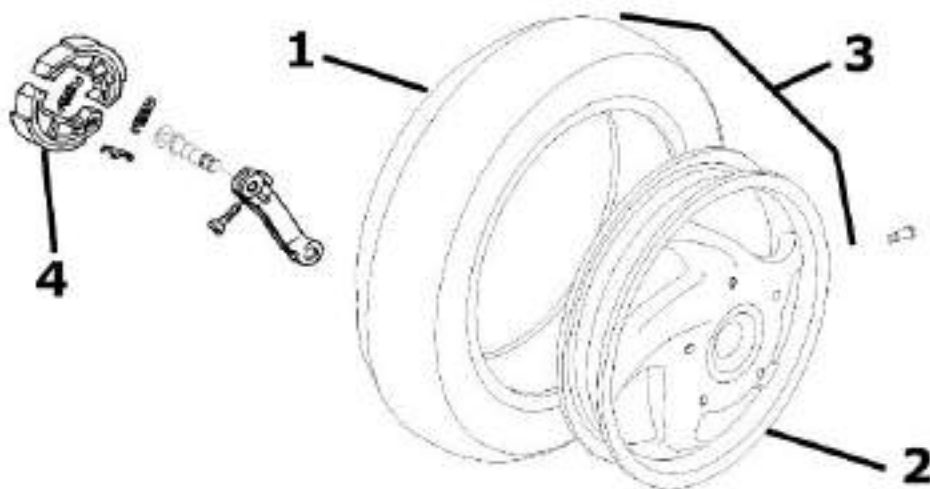

**REAR WHEEL**

	Code	Action	Duration
1	004126	Rear wheel tyre - Replacement	
2	001071	Rear wheel rim - Removal and Refitting	
3	001016	Rear wheel - Replacement	
4	002002	Rear brake pads/shoes - Repl.	

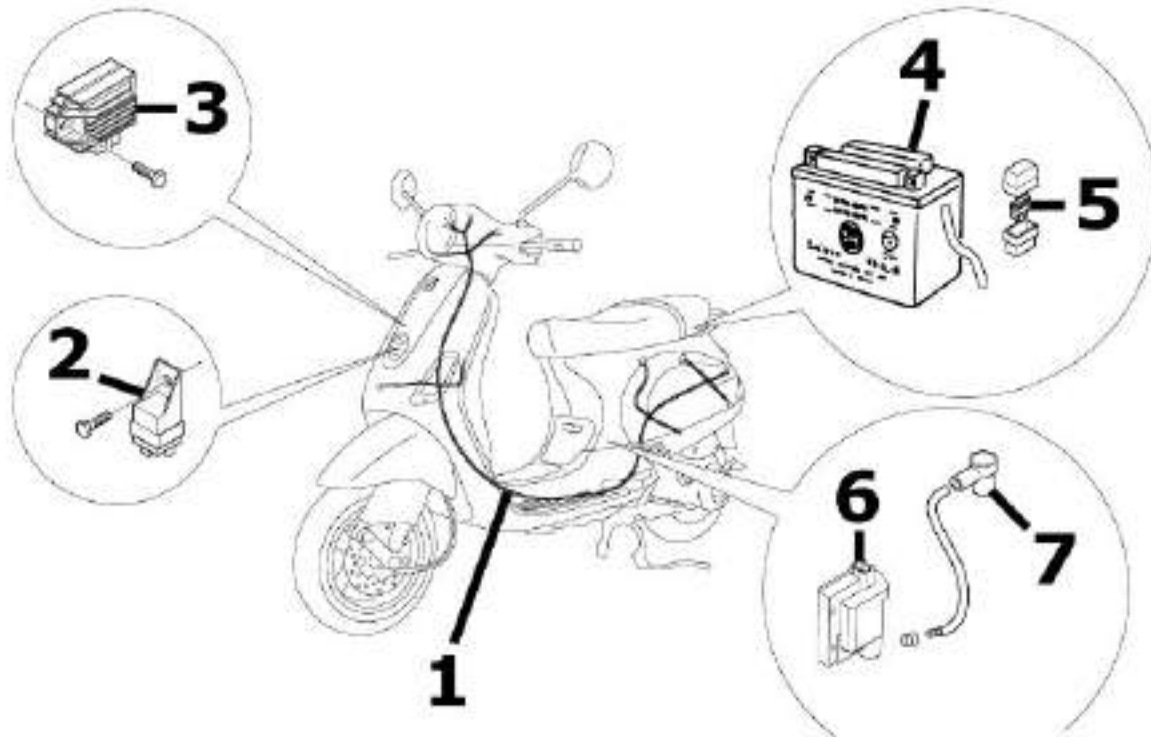
**Electric devices****ELECTRIC COMPONENTS**

	Code	Action	Duration
1	005001	Electrical system - Replacement	
2	005011	Start-up remote control switch - Replacement	
3	005009	Voltage regulator - Replacement	
4	005007	Battery - change	
5	005052	Fuse (1) - Replacement	
6	001023	Control unit - Replacement	
7	001094	Spark plug cap - Replacement	

Electronic controls

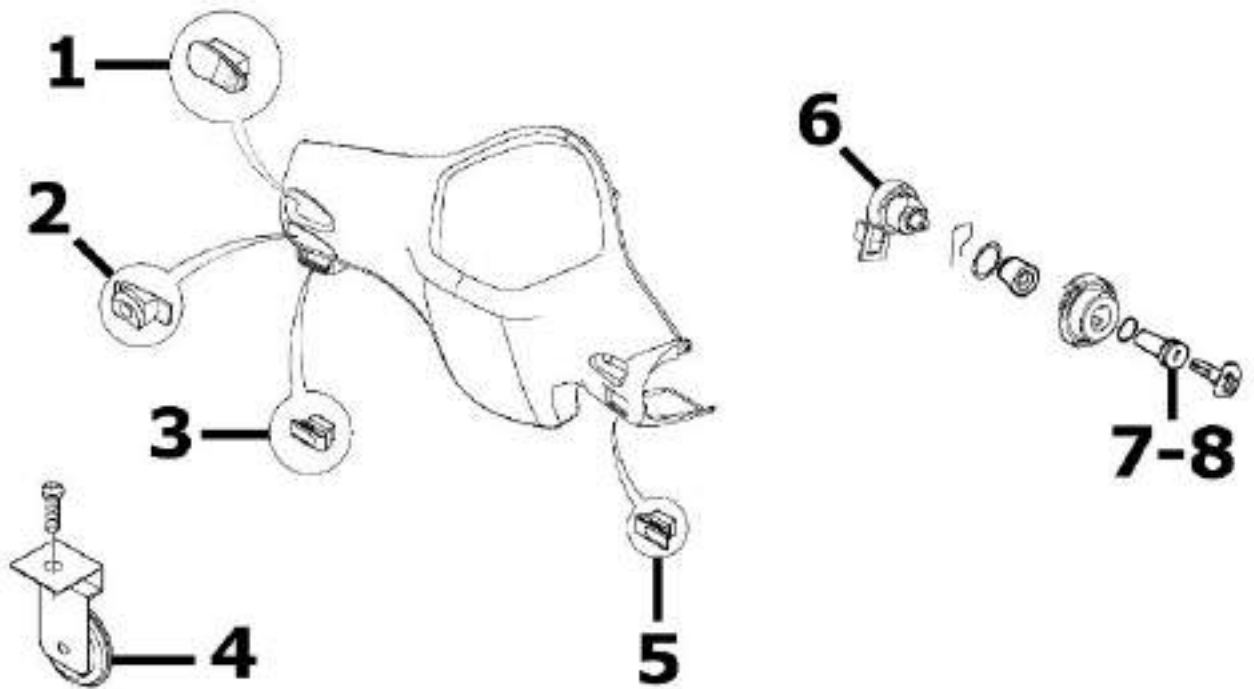

**ELECTRIC CONTROLS**

	<b>Code</b>	<b>Action</b>	<b>Duration</b>
1	005039	Lights switch - Replacement	
2	005006	Light or turning indicator switch - Replacement	
3	005040	Horn button - Replacement	
4	005003	Horn - Replacement	
5	005041	Starter button - Replacement	
6	005016	Key switch - Replacement	
7	004096	Lock series - Replacement	
8	004010	Anti-theft lock - Replacement	

## Transmissions

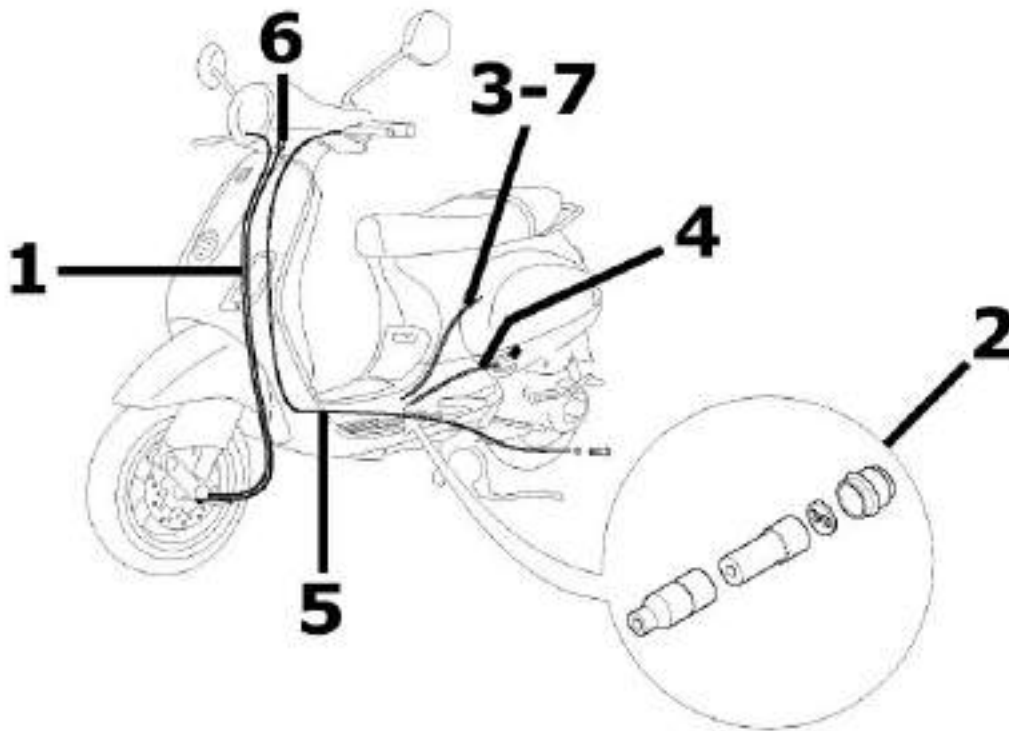

### TRANSMISSION

	Code	Action	Duration
1	002051	Odometer transmission assembly - Replacement	
2	002012	Splitter - Replacement	
3	002057	Carburettor / splitter transmission complete - Replacement	
4	002058	Mix / splitter transmission complete - Replacement	
5	002053	Rear brake transmission complete - Replacement	
6	002049	Odometer cable - Replacement	
7	003061	Accelerator transmission - adjust	

**Brake callipers**

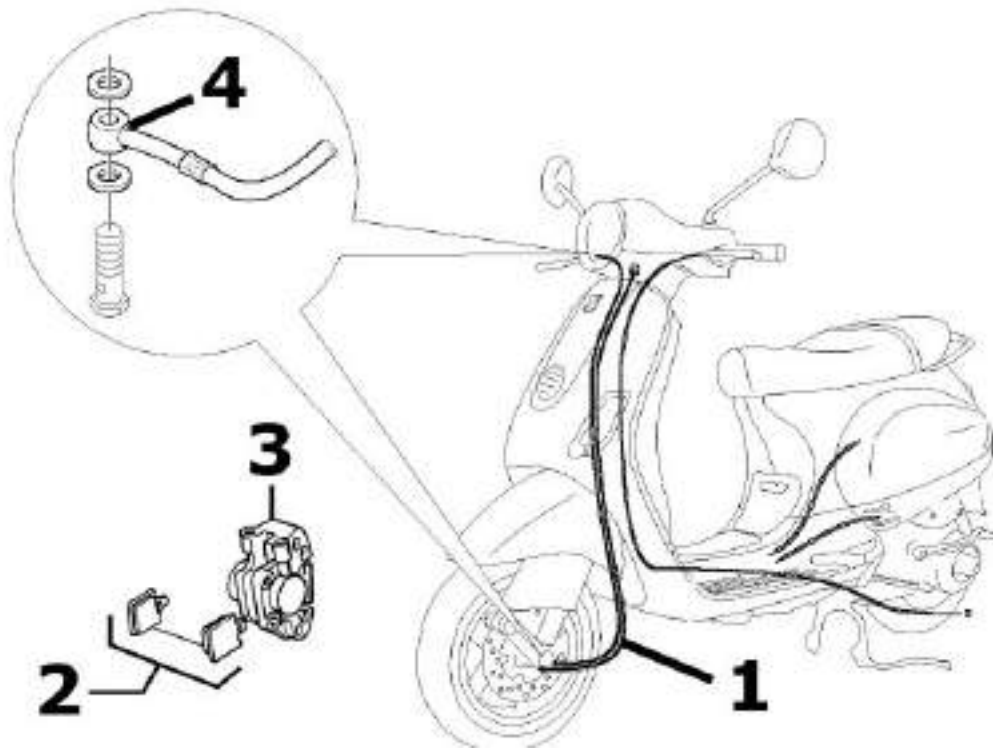

**CALLIPER**

	<b>Code</b>	<b>Action</b>	<b>Duration</b>
1	002021	Front brake hose - Remov. and Refitt.	
2	002007	Front brake shoes/pads - Remov. and Refitt	
3	002039	Front brake calliper - Removal and Refitting	
4	002047	Front brake fluid and air bleed system - Replacement	

## Front suspension

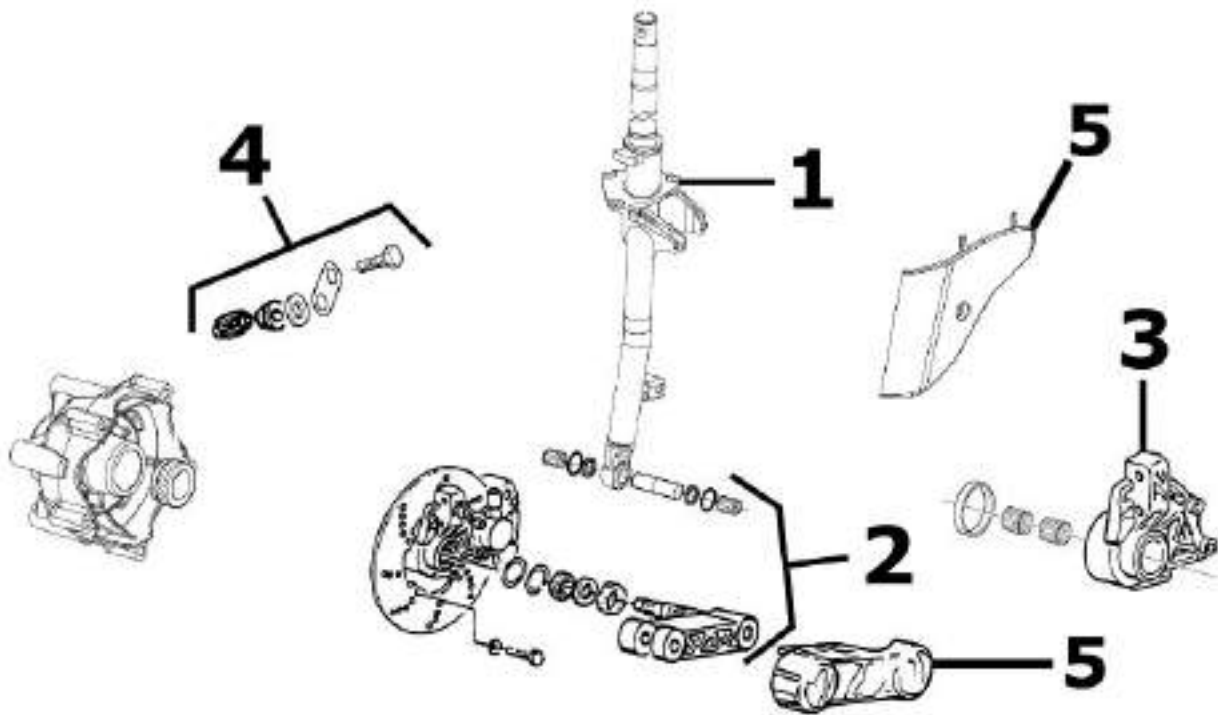

### FRONT SUSPENSION

	Code	Action	Duration
1	003045	Steering tube - Replacement	
2	003010	Front suspension - Service	
3	003035	Shock absorber support and brake calliper - Replacement	
4	001064	Odometer reel - Replacement	
5	003044	Shock absorber cover - Replacement	

## Secondary air box

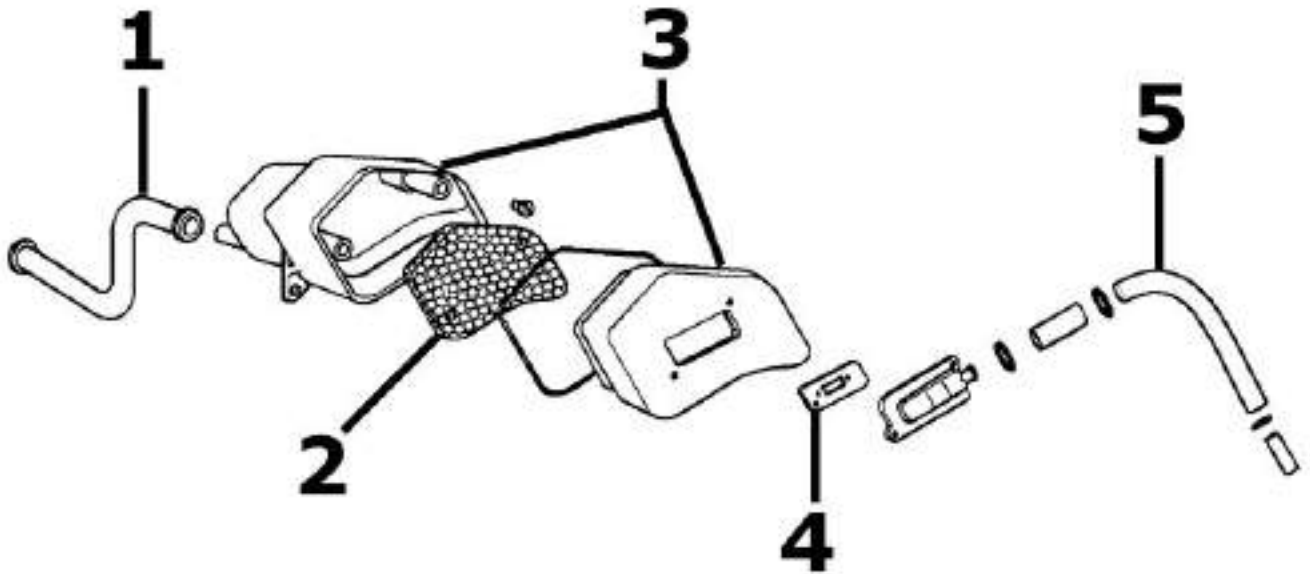

### SECONDARY AIR HOUSING

	Code	Action	Duration
1	001164	Crankcase secondary air connection - Replacement	
2	001161	Secondary air filter - Replacement / Cleaning	
3	001162	Secondary air housing - Replacement	
4	001163	Muffler secondary air connection - Replacement	
5	001165	Secondary air reed - Replacement	

## **A**

Air filter: 33, 116

## **B**

Battery: 42, 48, 54, 55

Brake: 108–112, 157

## **C**

Carburettor: 12, 30, 135

## **E**

Engine stop:

## **F**

Fuel: 41, 89, 145

## **H**

Headlight: 36, 115

Horn:

Hub oil: 32

## **I**

Identification: 8

Instrument panel: 114

## **M**

Maintenance: 7, 28

## **S**

Saddle:

Shock absorbers: 105

Spark plug: 31

Stand:

Start-up:

## **T**

Tank: 145, 146

Transmission: 10, 41, 61, 132

Turn indicators:

Tyres: 11