

Vespa®

MANUALE STAZIONE DI SERVIZIO



Vespa S 50 4T 4V (2008)



MANUALE STAZIONE DI SERVIZIO

Vespa S 50 4T 4V (2008)

The descriptions and illustrations given in this publication are not binding. While the basic specifications as described and illustrated in this manual remain unchanged, PIAGGIO-GILERA reserves the right, at any time and without being required to update this publication beforehand, to make any changes to components, parts or accessories, which it considers necessary to improve the product or which are required for manufacturing or construction reasons.

Not all versions/models shown in this publication are available in all countries. The availability of each model should be checked at the official Piaggio sales network.

"© Copyright 2008 - PIAGGIO & C. S.p.A. Pontedera. All rights reserved. Reproduction of this publication in whole or in part is prohibited."

PIAGGIO & C. S.p.A. - After-Sales

V.le Rinaldo Piaggio, 23 - 56025 PONTEDERA (Pi)

MANUALE STAZIONE DI SERVIZIO

Vespa S 50 4T 4V (2008)

Questo manuale per stazioni di servizio è stato realizzato da Piaggio & C. Spa per essere utilizzato dalle officine dei concessionari e sub-agenzie Piaggio-Gilera. Si presuppone che chi utilizza questa pubblicazione per la manutenzione e la riparazione dei veicoli Piaggio, abbia una conoscenza base dei principi della meccanica e dei procedimenti inerenti la tecnica della riparazione dei veicoli. Le variazioni importanti nelle caratteristiche dei veicoli o nelle specifiche operazioni di riparazione verranno comunicate attraverso aggiornamenti di questo manuale. Non si può comunque realizzare un lavoro completamente soddisfacente se non si dispone degli impianti e delle attrezzature necessarie, ed è per questo che vi invitiamo a consultare le pagine di questo manuale riguardanti l'attrezzatura specifica e il catalogo degli attrezzi specifici.

N.B. Provides key information to make the procedure easier to understand and carry out.

CAUTION Refers to specific procedures to carry out for preventing damages to the vehicle.

WARNING Refers to specific procedures to carry out to prevent injuries to the repairer.



Personal safety Failure to completely observe these instructions will result in serious risk of personal injury.



Safeguarding the environment Sections marked with this symbol indicate the correct use of the vehicle to prevent damaging the environment.



Vehicle intactness The incomplete or non-observance of these regulations leads to the risk of serious damage to the vehicle and sometimes even the invalidity of the guarantee.



INDEX OF TOPICS

CHARACTERISTICS

CHAR

TOOLING

TOOL

MAINTENANCE

MAIN

TROUBLESHOOTING

TROUBL

ELECTRICAL SYSTEM

ELE SYS

ENGINE FROM VEHICLE

ENG VE

ENGINE

ENG

SUSPENSIONS

SUSP

BRAKING SYSTEM

BRAK SYS

CHASSIS

CHAS

PRE-DELIVERY

PRE DE

TIME

TIME

INDEX OF TOPICS

CHARACTERISTICS

CHAR

Rules

Safety rules

- If work can only be done on the vehicle with the engine running, make sure that the premises are well ventilated, using special extractors if necessary; never let the engine run in an enclosed area. Exhaust fumes are toxic.
 - The battery electrolyte contains sulphuric acid. Protect your eyes, clothes and skin. Sulphuric acid is highly corrosive; in the event of contact with your eyes or skin, rinse thoroughly with abundant water and seek immediate medical attention.
 - The battery produces hydrogen, a gas that can be highly explosive. Do not smoke and avoid sparks or flames near the battery, especially when charging it.
 - Fuel is highly flammable and it can be explosive given some conditions. Do not smoke in the working area, and avoid naked flames or sparks.
 - Clean the brake pads in a well-ventilated area, directing the jet of compressed air in such a way that you do not breathe in the dust produced by the wear of the friction material. Even though the latter contains no asbestos, inhaling dust is harmful.
-

Maintenance rules

- Use original PIAGGIO spare parts and lubricants recommended by the Manufacturer. Non-original or non-conforming spares may damage the vehicle.
 - Use only the appropriate tools designed for this vehicle.
 - Always use new gaskets, sealing rings and split pins upon refitting.
 - After removal, clean the components using non-flammable or low flash-point solvents. Lubricate all the work surfaces, except tapered couplings, before refitting these parts.
 - After refitting, make sure that all the components have been installed correctly and work properly.
 - Use only equipment with metric sizes for removal, service and reassembly operations. Metric bolts, nuts and screws are not interchangeable with coupling members using English measurements. Using unsuitable coupling members and tools may damage the vehicle.
 - When carrying out maintenance operations on the vehicle that involve the electrical system, make sure the electrical connections have been made properly, particularly the ground and battery connections.
-

Vehicle identification

VEHICLE IDENTIFICATION

Specification	Desc./Quantity
Chassis prefix	ZAPC383000001001
Engine prefix	C383M

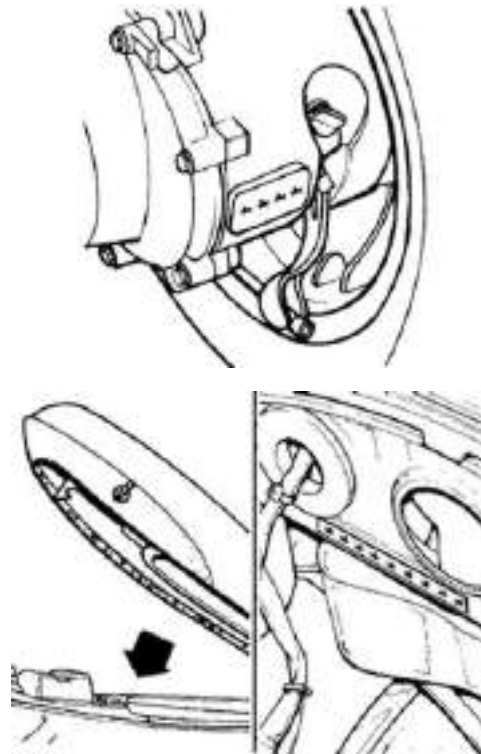

Dimensions and mass

WEIGHTS AND DIMENSIONS

Specification	Desc./Quantity
Width	740 mm
Length	1755 mm
Wheelbase	1290 mm
Maximum height	1140 mm
Kerb weight	110 ± 5 kg

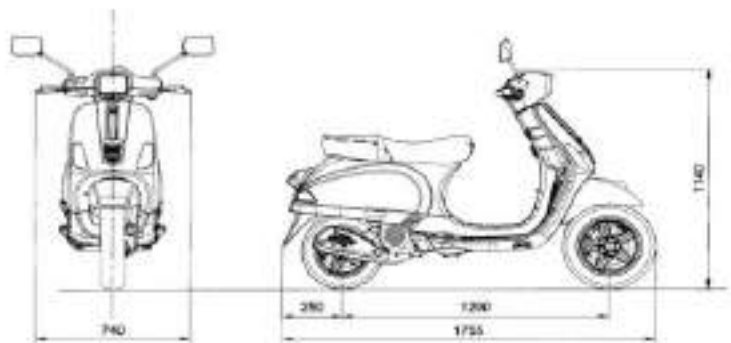

Engine

ENGINE

Specification	Desc./Quantity
Type	single-cylinder, four-stroke and four-valve, air-cooled engine

Specification	Desc./Quantity
Bore	39 mm
Stroke	41.8 mm
Engine capacity	49.93 cm ³
MAX Power	3.2 kW at 8250 rpm
MAX torque	3.8 Nm at 7750 rpm
Compression ratio	11.5 ÷ 12 : 1
Timing system	single overhead camshaft, chain-driven, on the left-hand side, three-arm rocking levers set up with threaded set screw
Engine idle speed	1900 ÷ 2000 rpm
Air filter	Sponge, soaked in a mixture (50% SELÉNIA Air Filter Oil and 50% unleaded petrol).
Starting system	electric starter/kick starter
Lubrication	engine lubrication with lobe pump (in the crankcase), chain-driven. Mesh pre-filter and centrifugal filter on the crankshaft
Fuel system	Gravity feed, with unleaded petrol (with a minimum octane rating of 95) with carburettor.
Valve clearance (cold engine)	intake 0.10 mm discharge 0.15 mm
Carburettor	depression type, KEIHIN NCV ø 20
Cooling	forced air circulation

OIL PUMP

Specification	Desc./Quantity
Type	Trochoidal
Distance between the rotors	Admissible limit clearance: 0.15 mm
Axial rotor clearance	Limit values admitted: 0.09 mm
Distance between the outer rotor and the pump body	Admissible limit clearance: 0.20 mm
Levelness	0.1 mm

OIL FILTER

Specification	Desc./Quantity
Type	mesh, plastic and centrifugal filter, before the oil pump and coaxially mounted onto the crankshaft keyed on the right crank

Transmission

TRANSMISSION

Specification	Desc./Quantity
Transmission	With automatic expandable pulley variator, torque server, V-belt, automatic clutch, gear reduction unit.

Capacities

CAPACITY

Specification	Desc./Quantity
Fuel tank (including a ~ 2 l reserve)	approx. 8.5 l
Rear hub	85 cm ³
Engine oil	~ 850 cc

Electrical system

When the advance check is carried out with a stroboscopic gun, add 10° flywheel keying to the table below.

MAPPA ATTIVAZIONE SAS (DUTY CYCLE%)
SAS setup map (duty cycle%)

N. 6 temperature values (°C)	N. 16 rpm values															
	500	3000	3500	4000	4600	5000	5500	5900	6500	7000	7400	8000	8400	9000	9500	10000
-20	0	10	30	0	0	0	0	0	0	0	0	0	0	0	0	0
0	0	20	20	0	0	0	0	0	0	0	0	0	0	0	0	0
+10	0	30	30	10	0	0	0	0	0	0	0	0	0	10	10	10
+35	0	47.5	47.5	27.5	0	0	0	0	0	0	0	0	12	22	22	22
+50	0	64	64	64	0	0	0	0	0	0	0	16	16	26	26	26
+57.5	0	60	60	60	20	0	0	0	0	0	20	25	25	35	35	35
+65	0	40	75	75	60	50	30	25	15	17.5	20.5	28	34	40	65	75
+135	0	40	75	75	60	50	30	25	15	17.5	20.5	28	34	40	65	75

ELECTRICAL COMPONENTS

	Specification	Desc./Quantity
1	Ignition advance	reference in table
2	Spark plug	NGK ER9EH-N
3	Battery	12V - 9Ah
4	Fuses	One 15A fuse - Two 7.5A fuses
5	Generator	single-phase alternating current

CHECKING REMOTE CONTROLS «A» OPERATING AS CIRCUIT BREAKERS

- 1) Check that, given regular conditions, there is no continuity between terminals 30 and 87.
- 2) Apply 12V voltage to power terminals 85 and 86 of the remote control.
- 3) With the remote control powered, check that there is continuity between terminals 30 and 87.
- 4) If these conditions are not fulfilled, the remote control is damaged and must be replaced.



TURN INDICATOR SWITCH

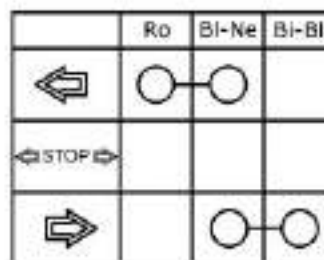

IGNITION KEY

	Ar	Rs-BI	BI	Ne
0 LOCK				
1 OFF				
2 ON				

LIGHT SWITCH

	Ma	GI-Ne	Vi

STARTER BUTTON

	BI-Ne	Ve-Ne

HORN BUTTON

	BI	Gr-Ne

STOP BUTTON

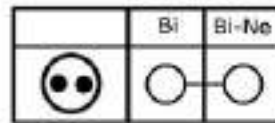

Resistance between green cable and ground connection: approx. 170 Ohm

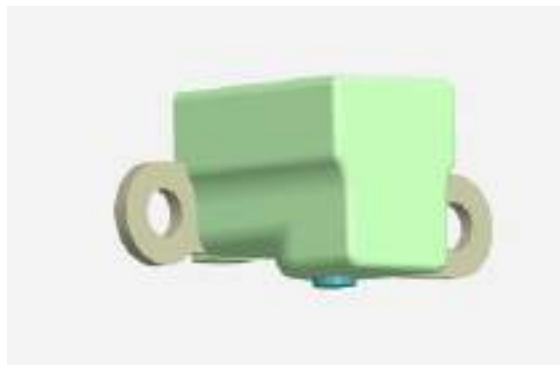

- Primary resistance: $0.5 \div 0.6$ Ohm
- Resistance between primary and ground connection: infinite
- Resistance between primary and HV output: $3 \div 3.6$ kOhm
- Shielded cap: 5000 Ohm



- Power: 120 W
- resistance between BLUE cable and GROUND CONNECTION: 1 Ohm

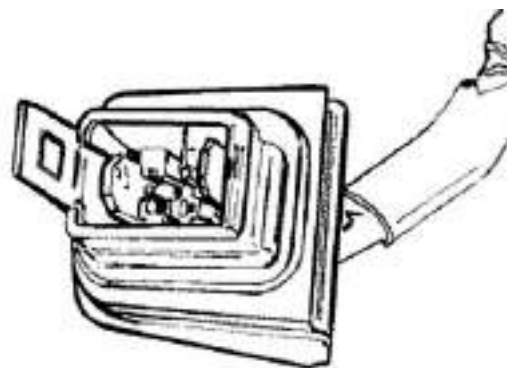

Frame and suspensions

CHASSIS AND SUSPENSION

Specification	Desc./Quantity
Type	Unitised body made of stamped plate

Specification	Desc./Quantity
Front suspension	Single arm suspension with swinging arm articulated to the steering tube. Hydraulic double-acting shock absorber and coaxial spring
Front suspension stroke	70 mm
Trail (suspension rebounded/compressed)	71/68 mm
Rear suspension	Single hydraulic double-acting shock absorber, helical coaxial spring. Chassis to engine support with swinging arm.
Rear suspension travel:	83.5 mm

Brakes

BRAKES

Specification	Desc./Quantity
Front	Disc brake, Ø 200 mm
Rear	Drum brake, Ø 110 mm

Wheels and tyres

WHEELS AND TYRES

Specification	Desc./Quantity
Front tyre size	110/70"-11"
Rear tyre size	120/70-10"
Front tyre pressure	1.6 bar
Rear tyre pressure:	2 bar
Light alloy rims (Front rim)	2.50" x 11"
Light alloy rims (rear rim)	3.00 x 10"

N.B.

CHECK AND ADJUST TYRE PRESSURE WITH TYRES AT AMBIENT TEMPERATURE. ADJUST PRESSURE ACCORDING TO THE WEIGHT OF RIDER AND ACCESSORIES.

Tightening Torques

STEERING ASSEMBLY

Name	Torque in Nm
Upper steering ring nut	30 to 40
Lower steering ring nut	8 to 10
Handlebar locking	50 to 55 Nm

FRAME ASSEMBLY

Name	Torque in Nm
Engine-swinging arm bolt	33 to 41
Frame-swinging arm bolt	44 to 52
Shock absorber - chassis nut	20 to 25
Shock absorber nut-engine	33 to 41
Rear wheel nut	104 to 126
Screws fixing the odometer reel plate	4 to 6

FRONT SUSPENSION

Name	Torque in Nm
Shock absorber upper nut	20 to 30
Front wheel axle nut	75 to 90
Shock absorber upper bracket bolts	20 to 25
Wheel rim screws	20 to 25
Shock absorber lower bolts (°)	20 to 27

(°) Lock these two bolts once the central upper nut of the shock absorber has been tightened.

N.B.

FOR SAFETY FASTENERS, SEE THE «PRE-DELIVERY» CHAPTER.

FRONT BRAKE

Name	Torque in Nm
Brake fluid pump-hose fitting	8 to 12
Brake fluid pipe-calliper fitting	20 to 25
Screw tightening calliper to support	20 to 25
Brake disc screw	5 to 6.5
Oil bleed valve (on the calliper)	10 to 12
Handlebar pump	7 to 10

ENGINE ASSEMBLY

Name	Torque in Nm
Ignition spark plug:	10 to 15 Nm
Floating head cover screws	6 - 7
Head-cylinder stud bolt nuts	6 to 7 + 90° + 90° *
Screws fixing head and cylinder to crankcase	8 to 10
Chain tensioner pad screw	5 to 7 Nm
Timing chain tensioner central screw	5 to 6
Camshaft pulley screw	12 to 14
Rocking lever axle and camshaft bearing screw	3 to 4 Nm
Rocking levers adjusting nuts:	7 to 9 Nm
Engine oil pre-filter cover:	25 to 28 Nm
Engine oil drainage cap	25 to 28
Flywheel nut	40 to 44 N.m
Stator screws	3 to 4
Pick-up screws	3 to 4
Oil pump bulkhead screw	4 to 5
Timing chain/oil pump compartment cover screws	4 to 5
Oil decantation labyrinth sheet screws	7 to 8
Oil pump crown screw	8 to 10
Screws fixing oil pump to the crankcase	5 to 6
Oil sump screws	8 to 10 Nm
Inlet manifold screw	7 - 9
Carburettor/manifold clamp screw	1.2 to 1.5
Screws fixing cables to starter motor	1.5 to 2.5
Starter screws	11 to 13
Transmission cover screws	11 to 13
Start-up lever screw	11 to 13
Crankcase cooling cover screw	2 to 2.5
Clutch assembly nut	55 to 60
Crankshaft pulley nut	18 to 20 + 90° Nm
Driven pulley shaft nut	40 to 44 Nm
Hub oil drainage screw	3 to 5 Nm
Rear hub cap screws	11 to 13
Crankcase half union screw	8 to 10

* When assembling the new stud bolts, nut tightening involves 3 turns of 90° each after the first locking at 6 to 7 Nm, consequently: 6 to 7 Nm + 90° + 90° + 90° at criss-crossed sequences.

Overhaul data**Assembly clearances**

Cylinder - piston assy.

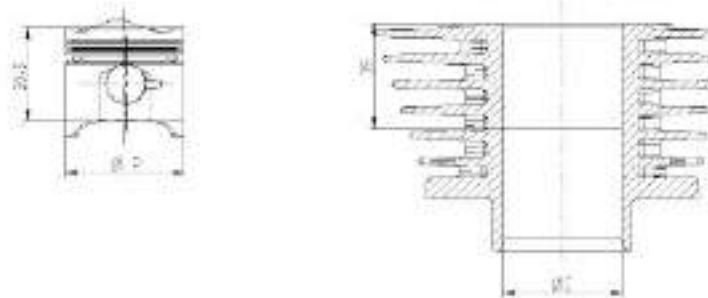

COUPLING BETWEEN PISTON AND CYLINDER

Name	Initials	Cylinder	Piston	Play on fitting
Cylinder	A	38.993 ÷ 39.000	38.954 ÷ 38.961	0.032 ÷ 0.046
Cylinder	B	39.000 ÷ 39.007	38.961 ÷ 38.968	0.032 ÷ 0.046
Piston	C	39.007 ÷ 39.014	38.968 ÷ 38.975	0.032 ÷ 0.046
Piston	D	39.014 ÷ 39.021	38.975 ÷ 38.982	0.032 ÷ 0.046
Cylinder 1st oversize	A1	39.193 to 39.200	39.154 to 39.161	0.032 to 0.046
Cylinder 1st oversize	B1	39.200 to 39.207	39.161 to 39.168	0.032 to 0.046
Piston 1st oversize	C1	39.207 to 39.214	39.168 to 39.175	0.032 to 0.046
Piston 1st oversize	D1	39.214 to 39.221	39.175 to 39.182	0.032 to 0.046
Cylinder 2nd oversize	A2	39.393 to 39.400	39.354 to 39.361	0.032 to 0.046
Cylinder 2nd oversize	B2	39.400 to 39.407	39.361 to 39.368	0.032 to 0.046
Piston 2nd oversize	C2	39.407 to 39.414	39.368 to 39.375	0.032 to 0.046
Piston 2nd oversize	D2	39.414 to 39.421	39.375 to 39.382	0.032 to 0.046
Cylinder 3rd oversize	A3	39.593 to 39.600	39.554 to 39.561	0.032 to 0.046
Cylinder 3rd oversize	B3	39.600 to 39.607	39.561 to 39.568	0.032 to 0.046
Piston 3rd oversize	C3	39.607 to 39.614	39.568 to 39.575	0.032 to 0.046
Piston 3rd oversize	D3	39.614 to 39.621	39.575 to 39.582	0.032 to 0.046

N.B.

THE PISTON MUST BE INSTALLED WITH THE ARROW FACING TOWARDS THE EXHAUST SIDE, THE PISTON RINGS MUST BE INSTALLED WITH THE WORD «TOP» OR THE STAMPED MARK FACING UPWARDS.

- Measure the outer diameter of the gudgeon pin.

Characteristic

Pin outside diameter

13 +0 -0.004 mm

Minimum admissible diameter gudgeon pin

12.990 mm

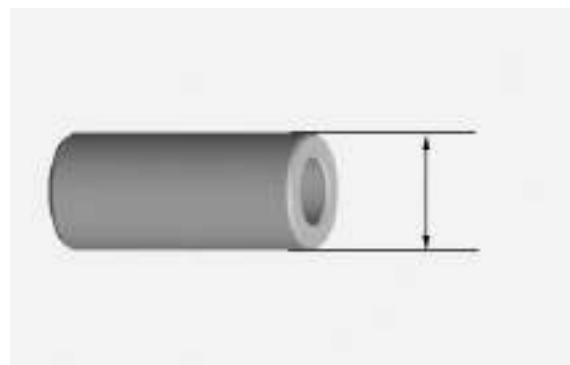

- Measure the diameter of the bearings on the piston.

Characteristic

Pin seat diameter

13 +0.005 + 0.010 mm

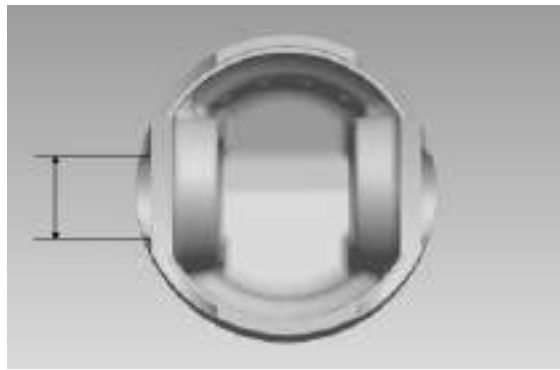

- Calculate the piston pin coupling clearance.

N.B.

THE PIN HOUSINGS HAVE 2 LUBRICATION CHANNELS. FOR THIS REASON, MEASUREMENT MUST BE MADE ACCORDING TO THE PISTON AXIS.

Characteristic

Standard clearance

0.005 to 0.014 mm

- Carefully clean the seal housings.
- Measure the coupling clearance between the sealing rings and the grooves using suitable sensors, as shown in the diagram.
- If the clearance is greater than that indicated in the table, replace the piston.

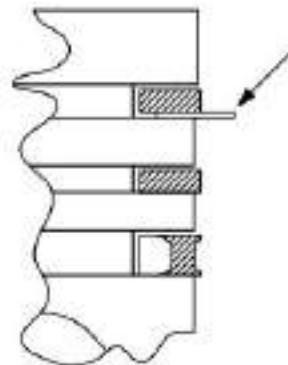

N.B.

MEASURE THE CLEARANCE BY INSERTING THE BLADE OF THE FEELER THICKNESS GAUGE FROM THE SECOND SEAL SIDE.

Fitting clearance

Top piston ring - standard coupling clearance

0.03 to 0.065 mm **Top piston ring - maximum clearance allowed after use** 0.07 mm

Middle piston ring - standard coupling clearance

0.02 to 0.055 mm **Middle piston ring - maximum clearance allowed after use** 0.06 mm

oil scraper ring - standard coupling clearance

0.04 to 0.16 mm **oil scraper ring - maximum clearance allowed after use**

0.17 mm

- Using a bore meter, measure the inner cylinder diameter at three different points according to the directions shown in the figure.
- Check that the coupling surface with the head is not worn or misshapen.

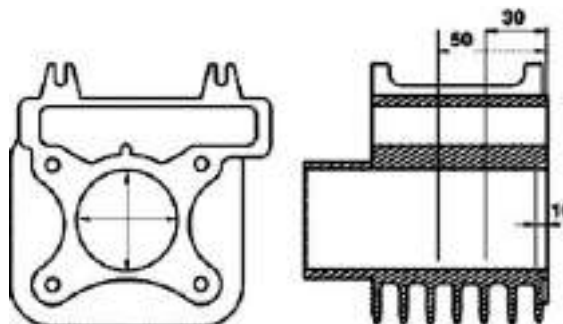

- Pistons and cylinders are classified into categories based on their diameter. The coupling is carried out in pairs (A-A, B-B, C-C, D-D).

Characteristic

Maximum allowable run-out:

0.05 mm



Piston rings

- Alternately insert the three sealing rings into the cylinder, in the area where it retains its original diameter. Using the piston, insert the rings perpendicularly to the cylinder axis.

- Measure the opening, see figure, of the sealing rings using a thickness gauge.

- If any measurements are greater than specified, replace the piston rings.

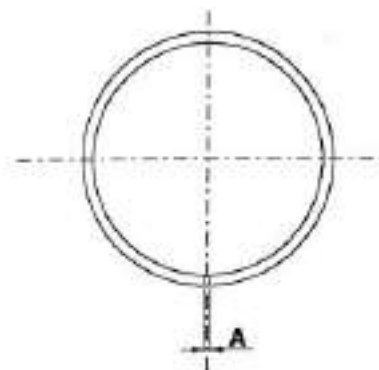

N.B.

BEFORE REPLACING ONLY THE PISTON RINGS, ENSURE THAT THE CLEARANCE BETWEEN THE PISTON RINGS AND THE PISTON RING GROOVES, AND BETWEEN THE PISTON AND THE CYLINDER, IS AS SPECIFIED. IN ANY CASE, NEW PISTON RINGS USED IN COMBINATION WITH A USED CYLINDER MAY HAVE DIFFERENT BEDDING CONDITIONS THAN THE STANDARD.

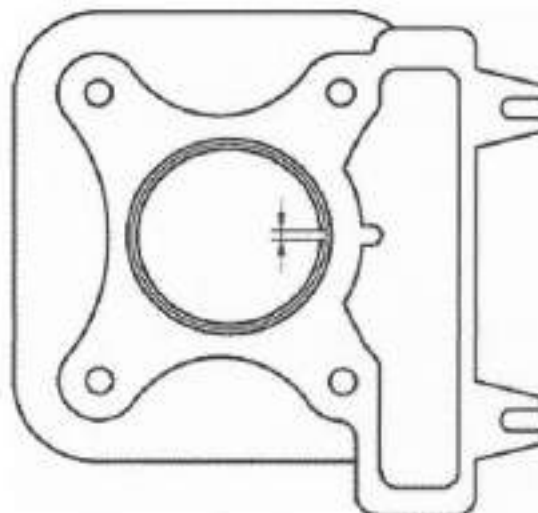

SEALING RINGS

Name	Description	Dimensions	Initials	Quantity
1st Compression ring		39 x 1	A	0.08 to 0.20

Name	Description	Dimensions	Initials	Quantity
2nd Compression ring		39 x 1	A	0.05 to 0.20
Oil scraper ring		39 x 2	A	0.20 to 0.70
1st Compression ring		39.2 x 1	A	0.08 to 0.20
1st Oversize				
2nd Compression ring		39.2 x 1	A	0.05 to 0.20
1st Oversize				
Oil scraper ring 1st		39.2 x 2	A	0.20 to 0.70
Oversize				
1st Compression ring		39.4 x 1	A	0.08 to 0.20
2nd Oversize				
2nd Compression ring		39.4 x 1	A	0.05 to 0.20
2nd Oversize				
Oil scraper ring 2nd		39.4 x 2	A	0.20 to 0.70
Oversize				
1st Compression ring		39.6 x 1	A	0.08 to 0.20
3rd Oversize				
2nd Compression ring		39.6 x 1	A	0.05 to 0.20
3rd Oversize				
Oil scraper ring 3rd		39.6 x 2	A	0.20 to 0.70
Oversize				

Crankcase - crankshaft - connecting rod

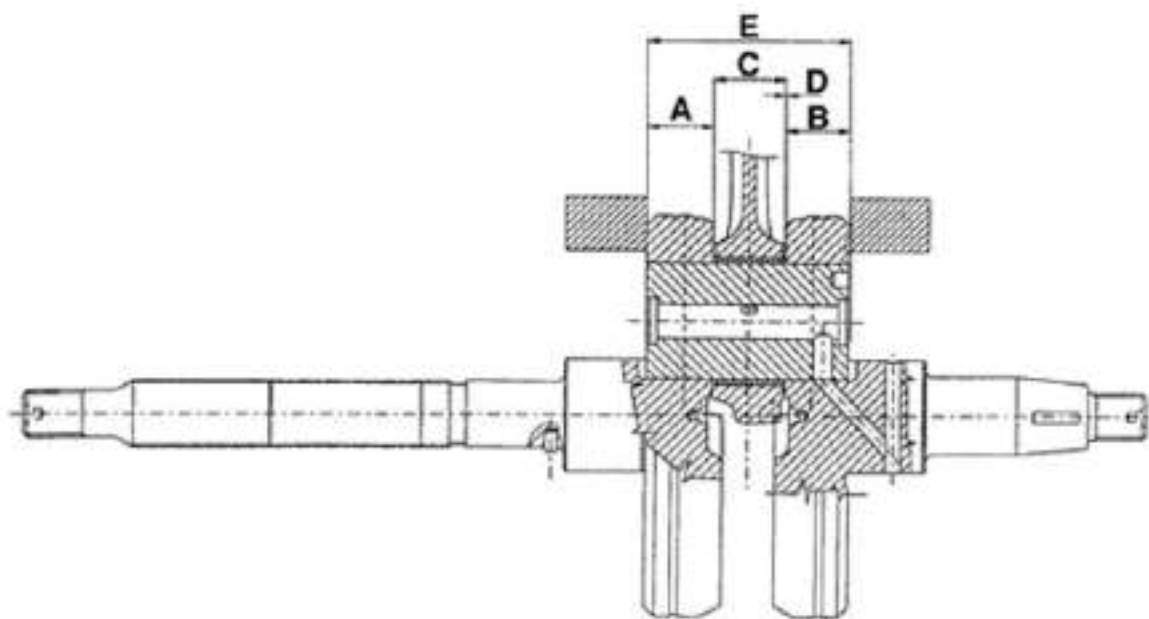

AXIAL CLEARANCE BETWEEN CRANKSHAFT AND CRANKCASE

Name	Description	Dimensions	Initials	Quantity
Transmissionside half-shaft		14 +0 -0.005	A	
Flywheel-side halfshaft		16 +0 -0.005	B	
Connecting rod		14.8 +0.05 -0	C	
Spacer tool		45.00 / Fits and clearances D = 0.15 to 0.30	E	

Characteristic

Clearance between crankshaft and connecting rod

A = 0.15 to 0.30 mm

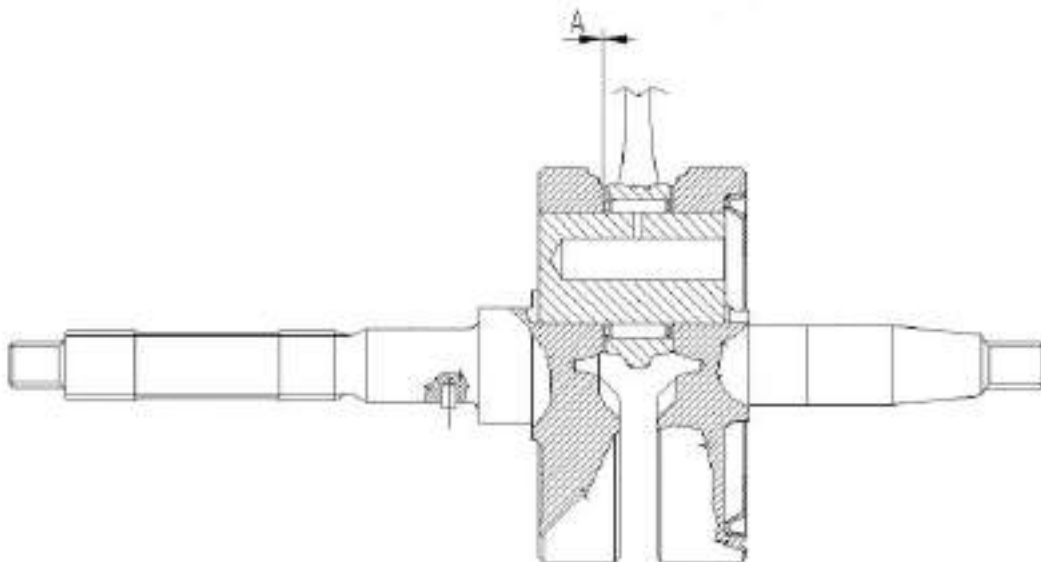

Measure the bearings along X and Y axes

Characteristic

Crankshaft bearing, transmission side

20 -0.012 -0.025 mm

Crankshaft bearing, flywheel side

17 +0.007 0 mm

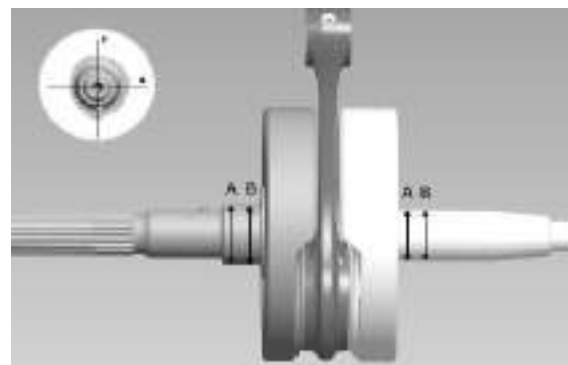

- Check that the driving shaft cone, the tab seat, the oil seal capacity, the toothed gear and the threaded tangs are in good working order.

- In case of failures, replace the crankshaft.

Specific tooling

020074Y Support base for checking crankshaft alignment

- Install the crankshaft on the support and measure the displacement at the 4 points shown in the figure.

N.B.

IF VALUES OTHER THAN THOSE ALLOWED ARE DETECTED, TRY STRAIGHTENING THE CRANKSHAFT BY INSERTING A WOODEN WEDGE BETWEEN THE HALF SHAFTS OR BY CLOSING THEM WITH A VICE AS NEEDED. IF EVEN AFTER THIS OPERATION THE VALUES ARE NOT THOSE ADMITTED, REPLACE THE CRANKSHAFT.

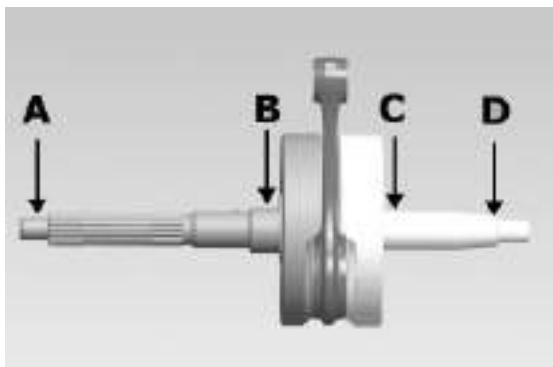
**Characteristic****Off-line maximum admitted - A**

0.15 mm

Off-line maximum admitted - B

0.02 mm

Off-line maximum admitted - C

0.02 mm

Off-line maximum admitted - D

0.10 mm

- Using a bore gauge, measure the connecting rod small end diameter.

N.B.

IF THE CONNECTING ROD SMALL END DIAMETER EXCEEDS THE STANDARD DIAMETER, EXHIBITS WEAR OR OVERHEATING, PROCEED TO REPLACE THE CRANKSHAFT AS DESCRIBED IN THE CRANKCASE AND CRANKSHAFT CHAPTER.

**Characteristic****Rod small end diameter**

13 +0.015 + 0.025 mm

Max. diameter admitted: check the small end

13.030 mm

Calculate the coupling clearance between pin and rod small end

Characteristic**Pin - connecting rod clearance**

0.015 - 0.029 mm

Cylinder Head

Before performing head service operations, thoroughly clean all coupling surfaces. Note the position of the springs and the valves so as not to change the original position during refitting

- Using a trued bar check that the cylinder head surface is not worn or distorted.
- Check that the camshaft and rocking lever pin bearings show no signs of wear.
- Check that the cylinder head cover surface, the intake manifold and the exhaust manifold are not worn.
- It is advisable to replace the head if any failure is found.

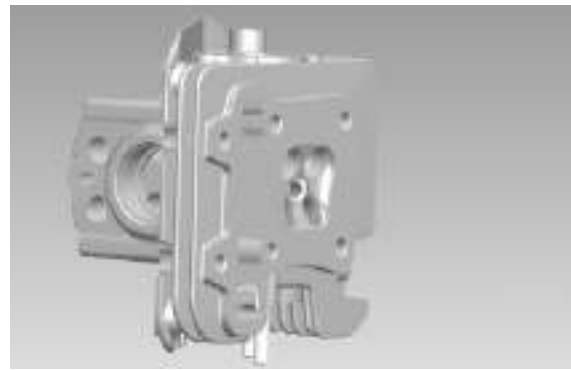

Characteristic

Maximum allowable run-out:

0.1 mm

- Insert the valves into the cylinder head.
- Alternatively check the intake and exhaust valves.
- The test is carried out by filling the manifold with petrol and checking that the head does not ooze through the valves when these are just pressed with the fingers.



Measure the camshaft bearing seats and rocking lever support pins with a bore meter

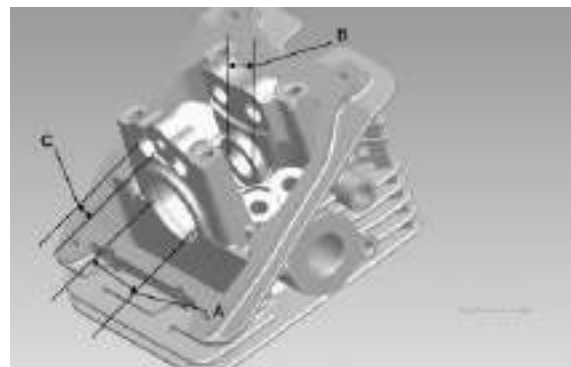

HEAD CHECK

Specification	Desc./Quantity
Standard diameter (mm) A	Ø 32.015 to 32.025 mm
Standard diameter (mm) B	Ø 16.0 to 16.018
Standard diameter (mm) C	Ø 11.0 to 11.018

Measure the unloaded spring length.

- Standard length: 31.3 mm
- Admissible limit after use: 29.3

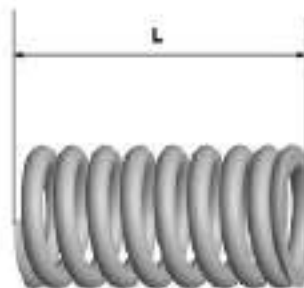

- Clean the valve seats of any carbon residues.
- Using the Prussian blue, check the width of the impression on the valve seat "V".

Characteristic

Standard value:

1 - 1.3 mm

Admissible limit:

1.6 mm

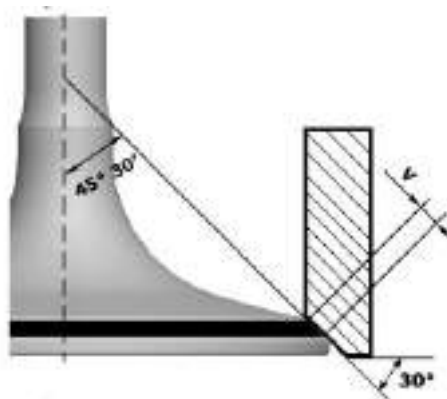

- If the impression width on the valve seat is larger than the prescribed limits, true the seats with a 45° mill and then grind.
- In case of excessive wear or damage, replace the head.

STANDARD VALVE LENGTH

Specification	Desc./Quantity
Inlet: standard length	74.9 mm
Outlet: standard length	74.35 mm



- Measure the diameter of the valve stems in the three positions indicated in the diagram.

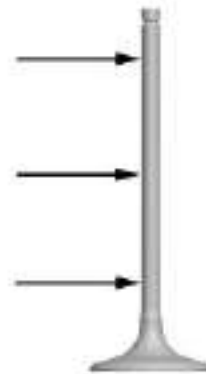

STANDARD DIAMETER

Specification	Desc./Quantity
Inlet	3.970 ÷ 3.985 mm
drainage	3.960 ÷ 3.975 mm

MINIMUM DIAMETER PERMITTED

Specification	Desc./Quantity
Inlet	3.958 mm
drainage	3.945 mm

- Calculate the clearance between valve and valve guide.

- Check the concentricity of the valve head by arranging a dial gauge at right angle relative to the valve head and rotate it on a "V" shaped abutment.

Characteristic
Admissible limit:
 0.03 mm

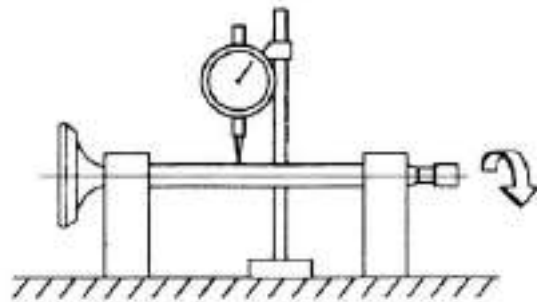

- Check the deviation of the valve stem by resting it on a «V» shaped abutment and measuring the extent of the deformation with a dial gauge.

Characteristic
Limit values admitted:
 0.1 mm

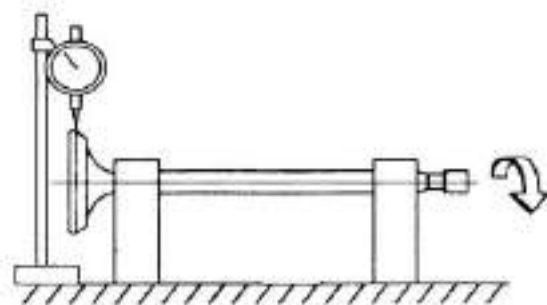

Measure the valve guides

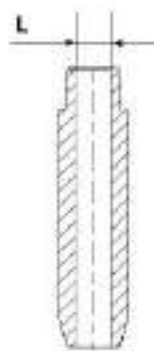

VALVE GUIDE DIAMETER

Specification	Desc./Quantity
Valve guide	Standard diameter: 4 + 0.012 mm
Valve guide	Maximum admissible diameter: 4 + 0.022 mm

- After measuring the valve guide diameter and the valve stem diameter, check clearance between guide and stem.



INTAKE

Specification	Desc./Quantity
Standard clearance	0.015 to 0.042 mm
Admissible limit	0.06 mm

EXHAUST

Specification	Desc./Quantity
Standard clearance	0.025 to 0.052 mm
Admissible limit	0.07 mm

- If no faults are found during the above checks, you can use the same valves. To obtain better sealing performance, grind the valve seats. Grind the valves gently with a fine-grained lapping compound. During the grinding, keep the cylinder head with the valve axes in a horizontal position. This will prevent the lapping compound residues from penetrating between the valve stem and the guide (see figure).

CAUTION

TO AVOID SCORING THE FAYING SURFACE, DO NOT KEEP ROTATING THE VALVE WHEN NO LAPPING COMPOUND IS LEFT. CAREFULLY WASH THE CYLINDER HEAD AND THE VALVES WITH A SUITABLE PRODUCT FOR THE TYPE OF LAPPING COMPOUND BEING USED.

CAUTION

DO NOT REVERSE THE FITTING POSITIONS OF THE VALVES (RIGHT - LEFT).

- Inspect the camshaft for signs of abnormal wear on the cams.

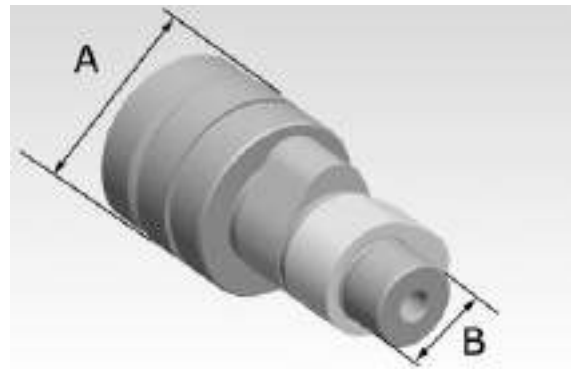

Characteristic

Standard diameter - Bearing A:

Ø 12 +0.002 +0.010

mm **Standard diameter - Bearing B:**

Ø 16-0.015 -0.023 mm

Minimum diameter allowed - Bearing A:

Ø 11.98 mm

Minimum diameter allowed - Bearing B:

Ø 15.96 mm

-Using a gauge, measure the cam height.

Check the axial clearance of the camshaft

- If any of the above dimensions are outside the specified limits, or there are signs of excessive wear, replace the defective components with new ones.

N.B.

A BALL BEARING IS FITTED ON BEARING «A»; CONSEQUENTLY, BEARING «B» IS THE MOST IMPORTANT AS IT WORKS DIRECTLY ON THE HEAD ALUMINIUM



Characteristic

Standard height - Inlet

24.397 mm

Standard height - Outlet

23.996 mm

Fitting clearance

Maximum admissible axial clearance: 0.5 mm

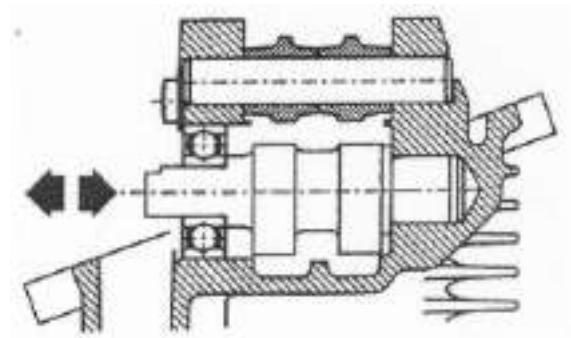

- Measure the outside diameter of the rocking lever pins
- Check the rocking lever pins do not show signs of wear or scoring.
- Measure the internal diameter of each rocking lever.
- Check that the pad in contact with the cam is not worn.

ROCKING LEVERS AND PIN DIAMETER:

Specification	Desc./Quantity
Rocking levers - Inside diameter	11.015 ÷ 11.035 mm
Rocking levers - Pins diameter	10.977 ÷ 10.985 mm



Slot packing system

Characteristic

Compression ratio

11.5 ÷ 12 : 1

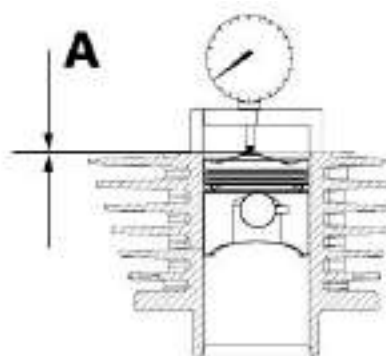

PISTON PROTRUSION CHECK

Name	Measure A	Thickness
shimming_1	1.7 ÷ 1.95	0.25
shimming_2	1.95 ÷ 2.2	0.35

Products

RECOMMENDED PRODUCTS TABLE

Product	Description	Specifications
AGIP ROTRA 80W-90	Rear hub oil	SAE 80W/90 Oil that exceeds the requirements of API GL3 specifications
AGIP CITY HI TEC 4T	Oil to lubricate flexible transmissions (brakes, throttle control and odometer)	Oil for 4-stroke engines
AGIP FILTER OIL	Oil for air filter sponge	Mineral oil with specific additives for increased adhesiveness
AGIP CITY HI TEC 4T	Engine oil	SAE 5W-40, API SL, ACEA A3, JASO MA Synthetic oil
AGIP GREASE MU3	Grease for odometer transmission gear case	Soap-based lithium grease with NLGI 3; ISO-L-XBCHA3, DIN K3K-20
AGIP BRAKE 4	Brake fluid	FMVSS DOT 4 Synthetic fluid
MONTBLANC MOLYBDENUM GREASE	Grease for driven pulley shaft adjusting ring and movable driven pulley housing	Grease with molybdenum disulphide
AGIP GREASE PV2	Grease for steering bearings, bolt seatings for swinging arms and faying surface of driven pulley spring (only pulley side)	Soap-based lithium and zinc oxide grease containing NLGI 2; ISO-L-XBCIB2
AGIP GP 330	Grease for brake lever, gas	White calcium complex soap-based spray grease with NLGI 2; ISO-L-XBCIB2

INDEX OF TOPICS







TOOLING





TOOL



TOOLS

Stores code	Description	
001467Y008	Pliers to extract 17 mm ø bearings	
001467Y029	Bell for bearings, O.D. 38 mm	
004499Y	Bearing extractor. Fitted with: 1 Bell, 2 Sleeve, 3 Screw, 6 Ring, 27 Half rings, 34 Half rings	
005095Y	Engine support	
008119Y009	Tube to assemble shafts and axles	
020004Y	Punch for removing steering bearings from headstock	

Stores code	Description	
020055Y	Wrench for steering tube ring nut	
020074Y	Tool to align crankshaft	
020150Y	Air heater mounting	
020151Y	Air heater	
020162Y	Flywheel extractor	
020171Y	Punch for driven pulley roller bearing	
020265Y	Bearing fitting base	

Stores code	Description	
020288Y	Fork to assemble piston on cylinder	
020291Y	Valve fitting/ removal tool	
020306Y	Punch for assembling valve seal rings	
020329Y	Mity-Vac vacuum-operated pump	
020330Y	Stroboscopic light to check timing	
020331Y	Digital multimeter	

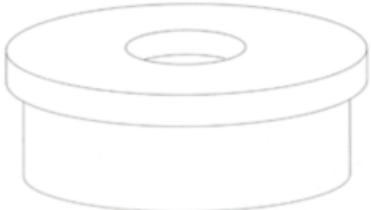
Stores code	Description	
020332Y	Digital rpm indicator	
020334Y	Multiple battery charger	
020335Y	Magnetic mounting for dial gauge	
020340Y	Flywheel and transmission oil seals fitting punch	
020358Y	37x40-mm Adaptor	
020359Y	42x47-mm Adaptor	

Stores code	Description	
020360Y	52x55-mm Adaptor	
020362Y	12 mm guide	
020363Y	20-mm guide	
020364Y	25-mm guide	
020376Y	Adaptor handle	
020431Y	Valve oil seal extractor	

Stores code	Description	
020432Y	Tool to fit the start-up sector spring	
020439Y	17-mm guide	
020444Y	Pin fitting/removal tool	
020448Y	Pin lock fitting tool	
020449Y	Piston position check support	
020450Y	Camshaft fitting/removal tool	
020451Y	Driving pulley lock wrench	
020452Y	Tube for removing and refitting the driven pulley shaft	

Stores code	Description
-------------	-------------

020456Y

Ø 24 mm adaptor



020565Y

Flywheel lock calliper spanner



020683Y

Valve pressing member



INDEX OF TOPICS

MAINTENANCE

MAIN

Maintenance chart

SCHEDULED MAINTENANCE TABLE

I: CHECK AND CLEAN, ADJUST, LUBRICATE OR REPLACE IF NECESSARY.

C: CLEAN, R: REPLACE, A: ADJUST, L: LUBRICATE

* Replace every 2 years

Km x 1000	1	3	6	9	12	15	18	21	24	27	30	33	36	39	42	45	48	51	54	57	60
Safety locks	I				I				I				I				I				I
Spark plug			R		R		R		R		R		R		R		R		R		R
Drive belt			I		R		I		R		I		R		I		R		I		R
Throttle control	A				A				A				A				A				A
Tyre condition and wear					I				I				I				I				I
Air filter					C				C				C				C				C
Oil filter (mesh)			C		C		C		C		C		C		C		C		C		C
Solenoid filter			C		C		C		C		C		C		C		C		C		C
Valve clearance	I				I				I				I				I				I
Electrical system and battery	I		I		I		I		I		I		I		I		I		I		I
Cylinder ventilation system									I								I				
Brake levers	L				L				L				L				L				L
Brake oil level (*)	I		I		I		I		I		I		I		I		I		I		I
Hub oil level	R		I		R		I		R		I		R		I		R		I		R
Engine oil	R	I	R	I	R	I	R	I	R	I	R	I	R	I	R	I	R	I	R	I	R
Brake Pads/Shoes	I		I		I		I		I		I		I		I		I		I		I
Tyre pressure	I		I		I		I		I		I		I		I		I		I		I
Headlight					A				A				A				A				A
Vehicle road test	I		I		I		I		I		I		I		I		I		I		I
Idle speed	A				A				A				A				A				A
Odometer gear					L				L				L				L				L
CVT rollers			I		R		I		R		I		R		I		R		I		R
Suspension					I				I				I				I				I
Steering	A				A				A				A				A				A
Transmission					L				L				L				L				L
Operation time	90'	10'	60'	10'	13 0'	10'	60'	10'	18 0'	10'	60'	10'	16 5'	10'	60'	10'	18 0'	10'	60'	10'	13 0'

Carburettor

The carburettor features a solenoid valve "A" that, via an ECU, manages an extra flow of air.

It is connected to the carburettor via flexible pipes as shown in the figure.

The valve is placed under the helmet compartment as shown in the picture.

Pipe "B" is coupled to a filter placed inside the body. The solenoid filter should be cleaned according to the kilometres travelled as instructed in the scheduled maintenance chart.



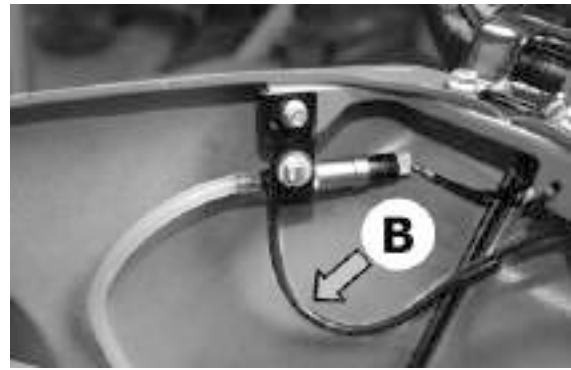

- Disassemble the carburettor in its parts, wash all of them with solvent, dry all body grooves with compressed air to ensure adequate cleaning.
- Check carefully that the parts are in good condition.
- The **throttle valve** should move freely in the chamber. Replace valve in case of wear due to excessive clearance.
- If there are wear marks in the chamber causing inadequate tightness or a free valve slide (even if it is new), replace the carburettor.
- It is advisable to replace the gaskets at every refit.

WARNING

PETROL IS HIGHLY EXPLOSIVE ALWAYS REPLACE THE GASKETS TO AVOID PETROL LEAKS

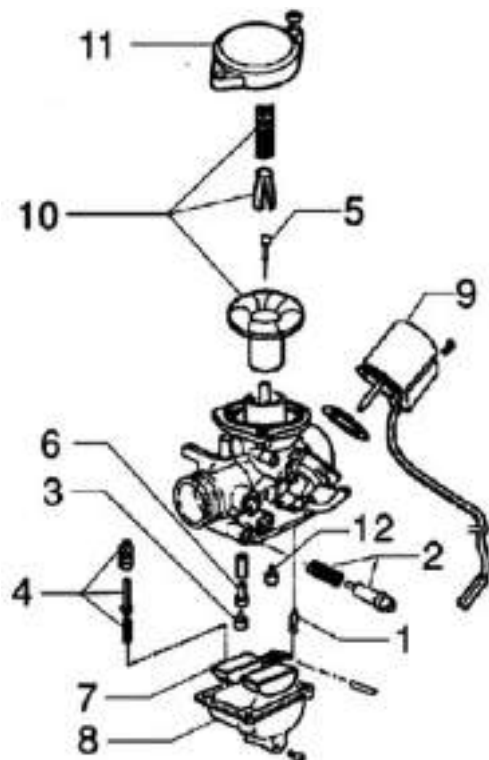

1. Needle valve - 2. Idle speed adjustment screw - 3. Max jet - 4. Accelerating pump - 5. Tapered pin - 6. Jet holder - 7. Float - 8. Chamber - 9. Starter device - 10. Vacuum valve - 11. Cover - 12. Minimum jet.

Checking the spark advance

The vehicle is fitted with a variable advance electronic device. There are two timing references on the flywheel cover in order to ensure a better precision when detecting the reference on the fan.

CAUTION

SHOULD THE FLASH INDICATIONS BE UNSTABLE AND THE RPM INDICATION DOES NOT CORRESPOND WITH THE TRUE ENGINE SPEED VARIATION (FOR EXAMPLE, VALUES SHOWN ARE HALVED), INSTALL A 10 to 15 K Ω RESISTIVE CABLE CONNECTED IN SERIES TO AN HV CABLE. IF THE IRREGULAR READING CONTINUES AFTER THIS OPERATION, CHECK THE COMPONENTS OF THE IGNITION SYSTEM.

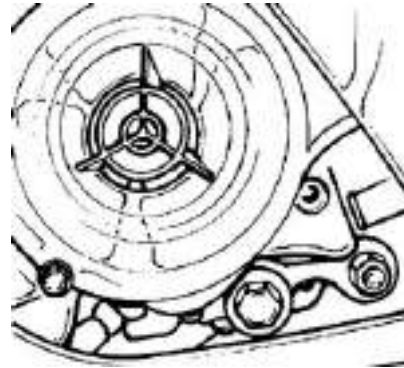

When the advance check is carried out with a stroboscopic gun, add 10° flywheel keying to the table below.

MAPPA ATTIVAZIONE SAS (DUTY CYCLE%)
SAS setup map (duty cycle%)

N. 6 temperature values (°C)	N. 16 rpm values															
	500	3000	3500	4000	4600	5000	5500	5900	6500	7000	7400	8000	8400	9000	9500	10000
-20	0	10	30	0	0	0	0	0	0	0	0	0	0	0	0	0
0	0	20	20	0	0	0	0	0	0	0	0	0	0	0	0	0
+10	0	30	30	10	0	0	0	0	0	0	0	0	0	10	10	10
+35	0	47.5	47.5	27.5	0	0	0	0	0	0	0	0	12	22	22	22
+50	0	64	64	64	0	0	0	0	0	0	0	16	16	26	26	26
+57.5	0	60	60	60	20	0	0	0	0	0	20	25	25	35	35	35
+65	0	40	75	75	60	50	30	25	15	17.5	20.5	28	34	40	65	75
+135	0	40	75	75	60	50	30	25	15	17.5	20.5	28	34	40	65	75

Spark plug

Disconnect and remove the spark plug tube.

- Examine it carefully and replace it if the insulator is chipped or cracked.
- Measure electrode gap with a thickness gauge and, if necessary, adjust the gap by carefully bending the outer electrode forward or away.
- Make sure the sealing washer is in good conditions.

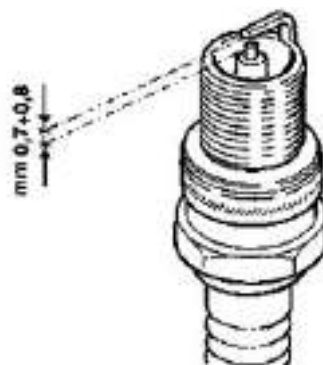

- Fit the spark plug, screw it manually and lock it to the prescribed torque with a spark plug spanner.

Electric characteristic

Spark plug

NGK ER9EH-6N

Distanza elettrodi:

0,6 mm

Locking torques (N*m)

Spark plug 8 ÷ 10

Hub oil

Check

Rest the vehicle on its centre stand on an even surface.

- Unscrew the oil dipstick "A", dry it with a clean cloth and reinsert it, **screwing it in thoroughly**.
- Pull out the dipstick and check that the oil level is above the "middle" notch (dipstick with 3 notches). For dipsticks with 2 notches, the oil level must remain in the lower half of the dipstick.
- Screw up the oil dipstick again and make sure it is locked properly into place.

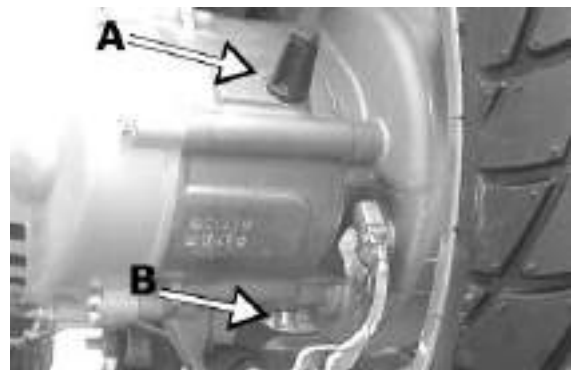

Recommended products

AGIP ROTRA 80W-90 rear hub oil

SAE 80W/90 Oil that exceeds the requirements of API GL3 specifications

Replacement

Remove the oil filler cap/dipstick "A".

- Unscrew the oil drainage plug "B" shown in the figure and drain out all the oil.
- Screw the drainage plug back and fill up the hub with the required oil (about 100 cm³)

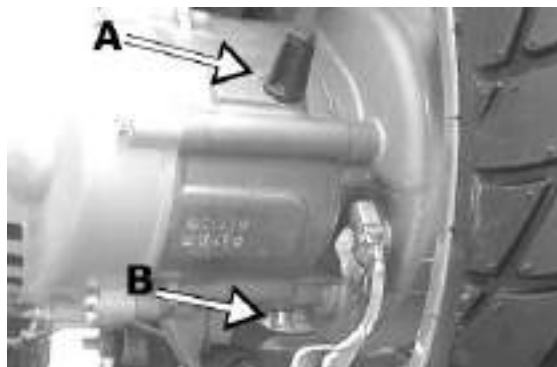

Air filter

Once the lower section of the left side cover has been removed, take out the air cleaner cap by unscrewing the 4 fixing screws and the 2 knobs (they can be reached by tipping the saddle and removing the helmet compartment); afterwards, remove the filtering element.

Cleaning:

- Wash with water and car shampoo;
- Dry with a clean cloth and short blasts of compressed air; do not wring;
- Immerse it in a mixture of 50% oil and 50 % petrol.
- Allow the filtering element to drip dry and then press it in your hands but without squeezing.

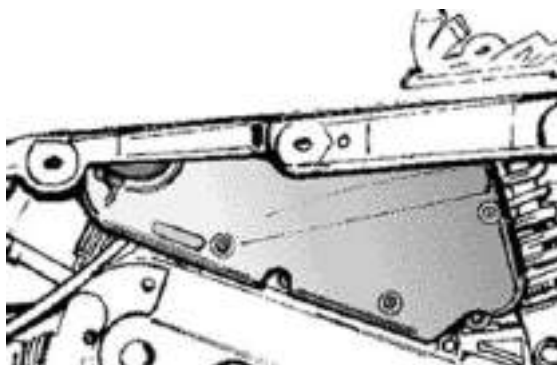

CAUTION

NEVER RUN THE ENGINE WITHOUT THE AIR FILTER, THIS WOULD RESULT IN AN EXCESSIVE WEAR OF THE PISTON AND CYLINDER.

Engine oil

Replacement

Loosen the oil filler plug.

- Unscrew the drainage plug from the mesh filter on the flywheel side, and let the oil drain off.
- Tighten the drainage plug and refill with ~ 600-650 cm³ of oil.



Check

Park the vehicle on a level surface and rest it on its stand (cold engine).

- Check that the oil level is between the MAX and MIN marks on the dipstick.
- The MAX level reference indicates ~ 850 cm³ in the engine.
- If the oil level is close to the MIN mark, top-up by adding oil but do not exceed the MAX level.

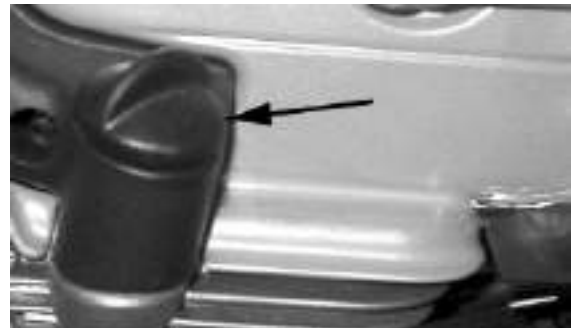

Recommended products

AGIP CITY HI TEC 4T Oil to lubricate flexible transmissions (brakes, throttle control and odometer)

Oil for 4-stroke engines



Engine oil filter

- Change oil when the engine is hot.
- Place a container under the oil sump and remove the oil drainage cap.
- After draining the oil, clean the mesh filter with a specific solvent and then blow it with compressed air.
- The filter can be reached after removing cap "A" (see figure).

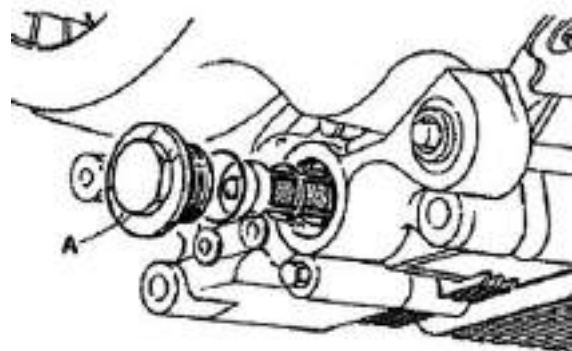

- After this operation, refit the filter and screw the oil cap at the prescribed torque using a new O-Ring
- Refill the engine with oil through the oil filling hole located in the oil sump.
- Engine oil capacity: ~ 850 cc.
- Lock the cap manually.

N.B.

Run the engine for a couple of minutes and check the oil level when the engine is cold. The level should always be below the MAX mark

N.B.

For the first top-up or when servicing, add 850 cm³ of engine oil; for any other case, add 650 cm³ and top-up, if required.

Recommended products**AGIP CITY HI TEC 4T Engine oil**

SAE 5W-40 Synthetic oil that exceed the requirements of API SL, ACEA A3, JASO MA specifications

Locking torques (N*m)

Engine oil pre-filter cover 25 to 28 Nm

Checking the ignition timing

- Turn the flywheel clockwise until its 2nd notch coincides with the Pick-up reference mark as shown in the figure.

Make sure that the reference point on the camshaft command crown is aligned with the reference point on the head as shown in the second figure.

If the reference is opposite the indicator on the head, turn the crankshaft once more as the piston must be at the TDC of the bursting phase.

N.B.

TIME THE TIMING SYSTEM UNIT IF IT IS NOT IN PHASE, AS DESCRIBED IN CHAPTER 6

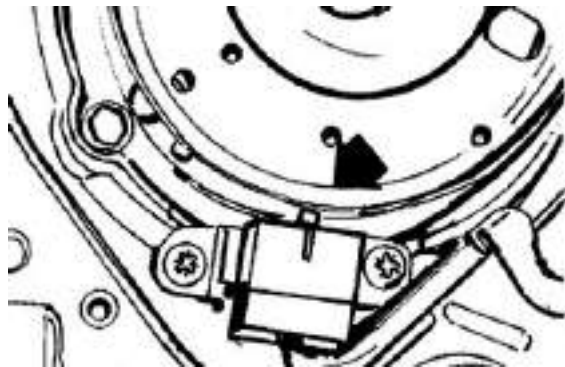

Checking the valve clearance

- Remove the spark plug access cover, undo the 4 fixing screws indicated in the figure and remove the tappet cover.
- To check valve clearance, centre the reference marks of the timing system point as described above.
- Use a thickness gauge to check valve clearance
- If the valve clearance values, inlet and outlet respectively, differ from those indicated below, replace the calibrated pads in order to restore the correct valve clearance.

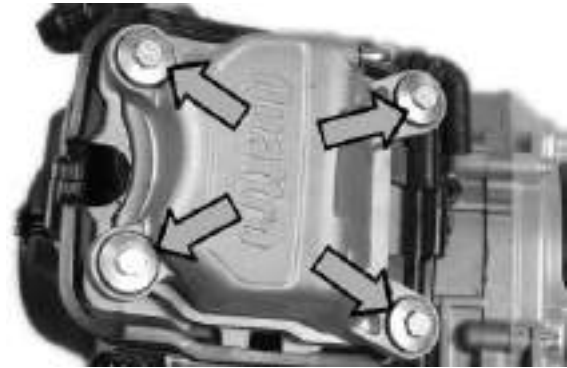

Characteristic

Inlet (with cold engine)

0.10 mm

Outlet (with cold engine)

0.15 mm

Headlight adjustment

Proceed as follows:

1. Place the vehicle in running order and with the tyres inflated to the prescribed pressure, on a flat surface 10 m away from a white screen situated in a shaded area, making sure that the longitudinal axis of the vehicle is perpendicular to the screen;
2. Turn on the headlight and check that the borderline of the projected light beam on the screen is no higher than 9/10 or lower than 7/10 of the distance from the ground to the centre of the vehicle's headlamp;
3. If otherwise, adjust the right headlight with screw «A».

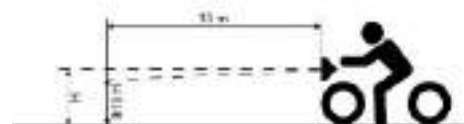

N.B.

THE ABOVE PROCEDURE COMPLIES WITH THE EUROPEAN STANDARDS REGARDING MAXIMUM AND MINIMUM HEIGHT OF LIGHT BEAMS. REFER TO THE STATUTORY REGULATIONS IN FORCE IN EVERY COUNTRY WHERE THE VEHICLE IS USED.

SAS filters inspection and cleaning

Undo the two screws «**A**» of the side fairing and remove the fairing. Undo the three screws «**B**» and remove the housing cover of the secondary air system. Detach the housing cover and remove the filtering element «**C**» made of sponge. Wash the sponge with water and neutral soap, then dry with a clean cloth and short blasts of compressed air. While cleaning the filter, check the condition of the reed valve «**D**», and fit it back in place on the housing.

Before closing the cover of the SAS housing, check the good condition of the sealing O-ring; replace it if damaged or deformed.

N.B.

The reed valve can be inserted in only one direction on the SAS housing



INDEX OF TOPICS

TROUBLESHOOTING

TROUBL

Engine

Poor performance

POOR PERFORMANCE

Possible Cause	Operation
Air filter obstructed or dirty.	Dismantle the sponge, wash with water and shampoo, then soak it in a mixture of 50% petrol and 50% Selenia Air Filter Oil, then allow to drip dry. Wring out water manually without squeezing and reassemble.
Carburettor nozzles clogged or dirty	Dismantle, wash with solvent and dry with compressed air
Dirty or faulty vacuum-operated cock	Check the filter on the cock, remove the petrol and wash the tank, if necessary. Replace the cock as a last resource.
Clutch slipping	Check the clutch system and/or the bell and replace if necessary
Inefficient automatic transmission	Check the rollers and the pulley movement, replace the damaged parts and lubricate the driven pulley moveable guide with Montblanc Molybdenum Grease
Lack of compression: parts, cylinder and valves worn	Replace the worn parts
Oil level exceeds maximum	Check for causes and fill to reach the correct level
Excess of scales in the combustion chamber	Descale the cylinder, the piston, the head and the valves
Incorrect timing or worn timing system elements	Time the system again or replace the worn parts (see 50 four stroke Engines manual)
Silencer obstructed	Replace
Fuel filter on vacuum operated cock blocked	Clean the cock filter
Wrong valve adjustment	Adjust the valve clearance properly
Valve seat distorted	Replace the head unit
Worn cylinder, Worn or broken piston rings	Replace the piston cylinder assembly or just the piston rings

Rear wheel spins at idle

REAR WHEEL

Possible Cause	Operation
Idling rpm too high	Check the idling speed and, if necessary, adjust the C.O.
Clutch fault	Check the spring/friction mass and the clutch housing
Air filter housing not sealed	Correctly refit the filter housing and replace it if it is damaged
Purifier-carburettor fitting damaged	Replace

Starting difficulties

START-UP PROBLEMS

Possible Cause	Operation
Defective spark plug or with incorrect electrode gap	Check and if necessary replace the spark plug and the electrode gap
Flat battery	Check the state of the battery. If it shows signs of sulphation replace it and bring the new battery into service charging it for eight hours at a current of 1/10 of the capacity of the battery itself
Engine flooded	Start the vehicle keeping the throttle fully open alternately making the engine run for approx. five seconds and stopping for other five seconds. If however it does not start, remove the spark plug, the engine over with the throttle open being careful to keep the cap in contact with the spark plug and the spark plug grounded but away from its hole. Refit a dry spark plug and start the vehicle.
Vacuum operated cock failure	Check that fuel is adequately supplied through the pipe by applying a vacuum to the vacuum pipe

Possible Cause	Operation
Failing automatic starter on the carburettor	Check the electrical wiring and mechanical movement, replace if necessary.
Wrong ignition advance	Check flywheel keying on the crankshaft, replace control unit if necessary
Incorrect valve sealing or valve adjustment	Inspect the head and/or restore the correct clearance
Rpm too low at start-up or engine and start-up system damaged	Check the starter motor and the system.
Altered fuel characteristics	Drain off the fuel no longer up to standard; then, refill
Carburettor nozzles clogged or dirty	Dismantle, wash with solvent and dry with compressed air

Engine tends to cut-off at full throttle

ENGINE STOP FULL THROTTLE

Possible Cause	Operation
Maximum jet clogged	Remove the carburettor, wash with solvent and dry with compressed air
Water or condensation in the carburettor chamber	Remove the chamber, wash with solvent and dry with compressed air or empty the tank through the appropriate bleed screw
Incorrect ignition advance	Use a stroboscopic light to check ignition advance and the flywheel correct keying
Air filter blocked or dirty.	Dismantle the sponge, wash with water and shampoo, then soak it in a mixture of 50% petrol and 50% of specific oil (Selenia Air Filter Oil), then hand dry without squeezing, allow to drip dry and then reassemble.
Incorrect float level	Restore the correct level in the chamber (the float must be parallel to the upper cover contact plane, that is the throttle valve membrane cover)
Fuel supply pipes choked or clogged	Restore the adequate fuel supply
Tank breather hole obstructed	Restore the proper reservoir aeration
Level in chamber too low	Restore the correct level in the chamber (the float must be parallel to the upper cover contact plane, that is the throttle valve membrane cover)

Engine tends to cut-off at idle

ENGINE STOP IDLING

Possible Cause	Operation
Air calibrated holes in carburettor blocked	Dismantle, wash with solvent and dry with compressed air
Defective floating valve	Check the proper sliding of the float and the functioning of the valve
Level in chamber too high	Restore the correct level in the chamber (the float must be parallel to the upper cover contact plane, that is the throttle valve membrane cover)
The starter remains on	Check that the small piston slides smoothly and check the automatic starter power supply; replace it if required
Air filter blocked or dirty.	Dismantle the sponge, wash with water and shampoo, then soak it in a mixture of 50% petrol and 50% of specific oil (Selenia Air Filter Oil), then hand dry without squeezing, allow to drip dry and then reassemble.
Wrong idling adjustment	Correctly adjust the engine idling and check the level of the C.O.
Spark plug defective or faulty	Replace the spark plug with one with the specified degree and check the plug gap
Pressure too low at the end of compression	Check the thermal group seals and replace worn components
Incorrect timing	Time the system and check the timing system components

High fuel consumption

EXCESSIVE FUEL CONSUMPTION

Possible Cause	Operation
Air filter blocked or dirty.	Dismantle the sponge, wash with water and shampoo, then soak it in a mixture of 50% petrol and 50% of specific oil (Selenia Air Filter Oil), then hand dry without squeezing, allow to drip dry and then reassemble.
The starter remains on	Check that the starter runs correctly and it is properly powered
Loose nozzles	Check the maximum and minimum nozzles are adequately fixed in their fittings
Incorrect float level	Check and restore the correct fuel level in the chamber

Transmission and brakes

Clutch grabbing or performing inadequately

IRREGULAR CLUTCH PERFORMANCE OR SLIPPAGE

Possible Cause	Operation
Faulty clutch	Check that there is no grease on the masses. Check that the clutch mass faying surface with the bell is mainly in the centre with equivalent characteristics on the three masses. Check that the clutch casing is not scored or worn in an anomalous way

Insufficient braking

INEFFICIENT BRAKING

Possible Cause	Operation
Worn brake pads or shoes	Replace the brake pads or shoes and check for brake disk or drum wear conditions.
Air bubbles inside the hydraulic braking system	Carefully bleed the hydraulic braking system, (there must be no flexible movement of the brake lever).
Brake disc or drum deformed	Use a dial gauge to check the levelness of the disk with the wheel correctly fitted and the concentricity of the rear drum; check the brake disc screws are locked
Fluid leakage in hydraulic braking system	Elastic fittings, piston seals or brake pump breakdown, replace
Excessive clearance in the rear brake control cable	Adjust backlash with the appropriate adjuster on the shoe control lever
The brake fluid has lost its properties	Replace the front brake fluid and top up to the correct level in the pump
Return spring broken	Replace spring.
Shoe control bolt not lubricated	Lubricate with Z2 grease.

Brakes overheating

BRAKE OVERHEAT

Possible Cause	Operation
Defective plunger sliding	Check calliper and replace any damaged part.
Brake disc or drum deformed	Use a dial gauge to check the levelness of the disk with the wheel correctly fitted and the concentricity of the rear drum; check the brake disc screws are locked

Electrical system

Battery

BATTERY

Possible Cause	Operation
The battery is the electrical device in the system that requires the most frequent inspections and thorough maintenance.	The battery is the electrical device in the system that requires the most frequent inspections and thorough maintenance. If the vehicle is not used for some time (1 month or more) the battery needs to be recharged periodically. The battery runs down completely in the course of 5 to 6 months. If the battery is fitted on a motorcycle, be careful not to invert the connections, keeping in mind that the black earth wire is connected to the negative terminal while the red wire is connected to the terminal marked +.

Turn signal lights malfunction

ELECTRICAL SYSTEM MALFUNCTION

Possible Cause	Operation
Turn indicators do not turn on	Check turn indicators device and/or wiring as described in the «Electrical system» chapter.

Steering and suspensions

Heavy steering

STEERING HARDENING

Possible Cause	Operation
Steering hardening	Check the tightening of the top and bottom ring nuts. If irregularities continue in turning the steering even after making the above adjustments, check the seats in which the ball bearings rotate: replace them if they are recessed or if the balls are flattened.

Excessive steering play

EXCESSIVE STEERING CLEARANCE

Possible Cause	Operation
Excessive steering clearance	Check the tightening of the top ring nut. If irregularities continue in turning the steering even after making the above adjustments, check the seats in which the ball bearings rotate: replace if they are recessed.

Noisy suspension

NOISY SUSPENSION

Possible Cause	Operation
NOISY SUSPENSION	If the front suspension is noisy, check: that the front shock absorber works properly and the ball bearings are good condition.

Possible Cause

Operation

In conclusion, check the tightening torque of the wheel hub, the brake calliper, the shock absorber disk in the attachment to the hub and the steering tube.
 Check that the swinging arm connecting the engine to the chassis and the rear shock absorber work properly

Suspension oil leakage

OIL LEAKAGE FROM SUSPENSION

Possible Cause

Operation

Oil leakage from suspension

Replace the damper.

INDEX OF TOPICS

ELECTRICAL SYSTEM

ELE SYS

-
1. Light remote control
 2. Light switch
 3. Town light bulb
 4. Instrument panel lighting bulbs
 5. Headlight warning light
 6. Filament for rear position light
 7. High-beam warning light
 8. Headlight bulb
 9. Automatic starter
 10. NTC temperature sensor
 11. Electronic ignition device
 12. Turn indicator switch
 13. Left turn indicator bulbs
 14. Turn indicator warning light
 15. Right turn indicator bulbs
 16. HV coil
 17. Key switch contacts
 18. Diagnostics socket
 19. Fuse
 20. PTC
 21. Horn button
 22. Horn
 23. Stop buttons
 24. Low fuel warning light
 25. Fuel gauge
 26. S.I.S. Valve
 27. Voltage regulator
 28. Fuel level transmitter
 29. Stop light filament
 30. Starter button
 31. Starter motor
 32. Starter remote control switch
 33. Fuse
 34. Battery
 35. Key switch contacts
 36. Fuse
 37. Magneto flywheel
 38. Pick-Up

Colours of the electrical cables:

B = White, **Bl** = Blue, **G** = Yellow, **Mr** = Brown, **N**
= Black, **Gr** = Grey,
Rs = Pink, **R** = Red, **Vi** = Purple, **V** = Green

Conceptual diagrams

Ignition

- 11. Electronic ignition device
 - 16. HV coil
 - 17. Key switch contacts
 - 19. Fuse
 - 33. Fuse
 - 34. Battery
 - 35. Key switch contacts
 - 38. Pick-Up
-

Headlights and automatic starter section

- 1. Light remote control
 - 2. Light switch
 - 3. Town light bulb
 - 4. Instrument panel lighting bulbs
 - 5. Headlight warning light
 - 6. Filament for rear position light
 - 7. High-beam warning light
 - 8. Headlight bulb
 - 9. Automatic starter
 - 11. Electronic ignition device
 - 20. PTC
 - 27. Voltage regulator
 - 33. Fuse
 - 34. Battery
 - 35. Key switch contacts
 - 36. Fuse
 - 37. Magneto flywheel
-

Battery recharge and starting

- 23. Stop buttons
 - 27. Voltage regulator
 - 29. Stop light filament
 - 30. Starter button
 - 31. Starter motor
 - 32. Starter remote control switch
 - 33. Fuse
 - 34. Battery
 - 35. Key switch contacts
 - 36. Fuse
 - 37. Magneto flywheel
-

Level indicators and enable signals section

- 10. NTC temperature sensor
 - 11. Electronic ignition device
 - 24. Low fuel warning light
 - 25. Fuel gauge
 - 26. S.I.S. Valve
 - 28. Fuel level transmitter
 - 33. Fuse
 - 34. Battery
 - 35. Key switch contacts
 - 36. Fuse
-

Turn signal lights

- 12. Turn indicator switch
 - 13. Left turn indicator bulbs
 - 14. Turn indicator warning light
 - 15. Right turn indicator bulbs
 - 21. Horn button
 - 22. Horn
 - 27. Voltage regulator
 - 33. Fuse
 - 34. Battery
 - 35. Key switch contacts
 - 36. Fuse
-

37.Magneto flywheel

Instruments and warning lights control board

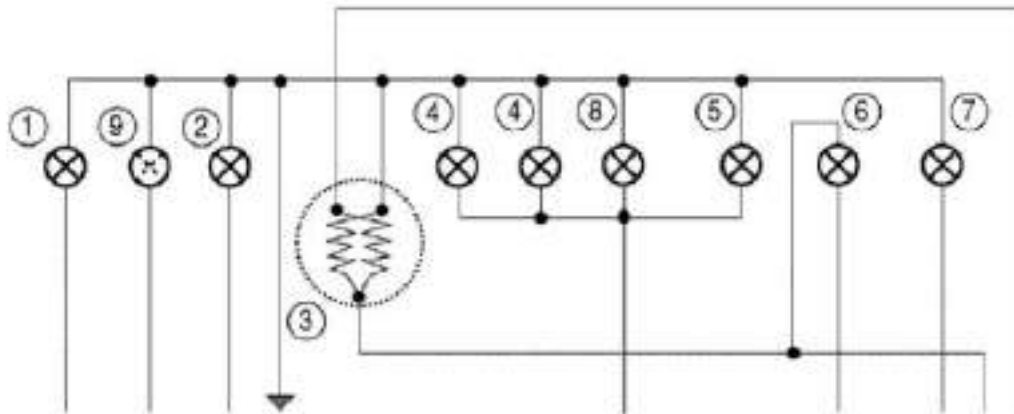

INSTRUMENT BOARD - WARNING LIGHTS AND INSTRUMENT PANEL

	Specification	Desc./Quantity
1	Left turn indicator warning light	12V - 2W
2	High-beam warning light	12V - 1.2W
3	Fuel gauge	
4	Instrument panel lighting bulbs	12V - 1.2W
5	Headlight warning light	12V 1.2W
6	Low fuel warning light	12V - 1.2W
7	Right turn indicator warning light	12V - 2W
8	Instrument panel lighting bulbs	12V - 2W
9	Pre-set warning light	

Checks and inspections

In case the cause of ignition failure or malfunction cannot be easily identified at sight, first of all replace the control unit by another one in operating conditions.

Remember that the engine must be off to disconnect and replace the control unit.

If after replacement the vehicle starts properly, the control unit is failing and must be replaced.

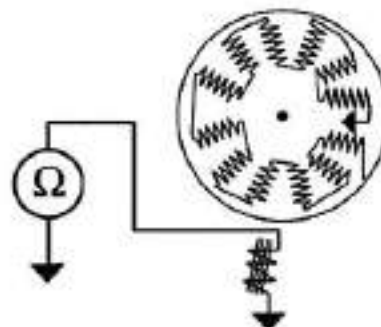

If the failure persists, check the generator and the stator components as follows:

After visually checking the electrical connections, use a specific tester to measurement the stator winding and the pickup (see table).

If any failure is found after checking the loading coil and the pick-up, **replace the stator and the damaged parts.**

Disconnect the connector on the flywheel cover and measure the resistance between either contact and the earthing.

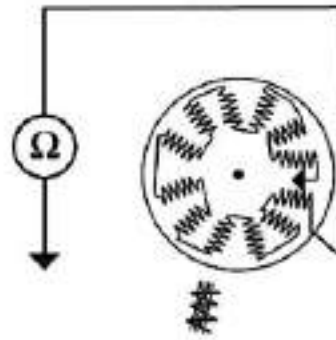

Specific tooling

020331Y Digital multimeter

PICK-UP CHECK

	Specification	Desc./Quantity
1	1) Brown cable and earth	~ 170 Ω

STATOR WINDING CHECK

	Specification	Desc./Quantity
1	1) Black cable and earth	~ 1 Ω

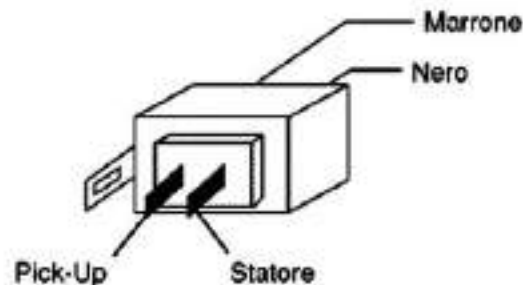

Ignition circuit

All the control operations of the system that require the disconnection of cables (checks of the connections and the devices making up the ignition circuit) must be done with the engine off: if this is not done, the controls might be irretrievably damaged.

No spark plug

Once the lack of power to the spark plug has been detected and the LED indicates it can be ignited, follow this procedure:

- Check the Pick-Up.

Disconnect the electronic starter connector and check continuity between terminal No. 3 (Green) and terminal No. 4 (Black).

The check includes the Pick-Up and its power line. If a break in the circuit is found, check again the flywheel and the engine earth connectors. If non-conforming values are measured, replace the Pick-Up; otherwise, repair the cable harness.

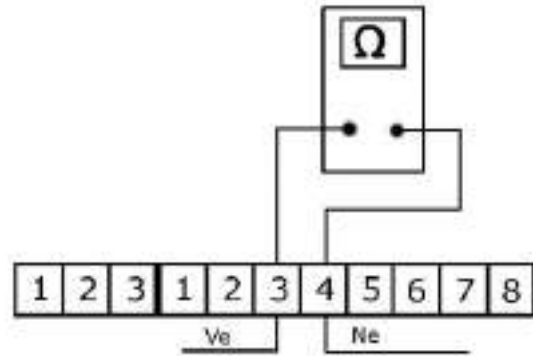

Electric characteristic

Pick - up resistance

approx. 170 Ohm

- HV primary coil check

Disconnect the electronic starter connector and check continuity between terminal No. 3 (purple) and terminal No. 1 (black) (see figure).

If non-conforming values are measured, check again the HV coil primary directly on the positive and negative terminals.

If the values are correct, repair the cable harness or reset the connections; otherwise, replace the HV coil

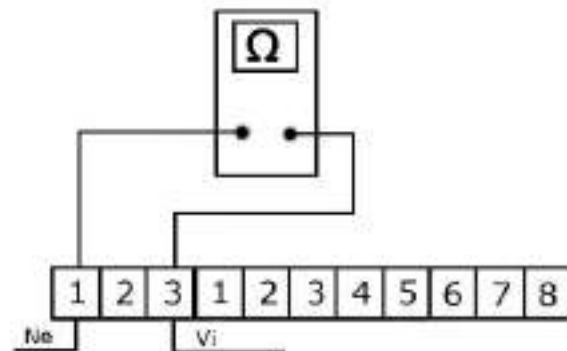

Electric characteristic

HV coil primary resistance

0.5 ÷ 0.6 Ohm

- HV coil secondary check

Disconnect the spark plug cap from the HV cable and measure the resistance between the HV cable terminal and the HV coil negative terminal (see figure).

If non-conforming values are measured, replace the HV coil. To carry out a more complete diagnosis, check the peak voltage with the multimeter adaptor.

Specific tooling

020409Y Multimeter adaptor - Peak voltage detection

Electric characteristic

HV coil secondary resistance

3000 ÷ 3600 Ohm

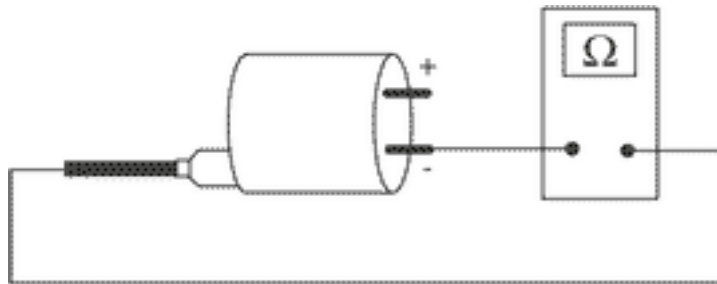
**- Pick-Up**

Disconnect the ECU connector and connect the positive terminal to connector No. 3 (green) and the negative terminal to connector No. 4 (black). Use the start-up system to run the engine and measure the voltage produced by the Pick-Up. Replace Pick-Up if non-conforming values are measured.

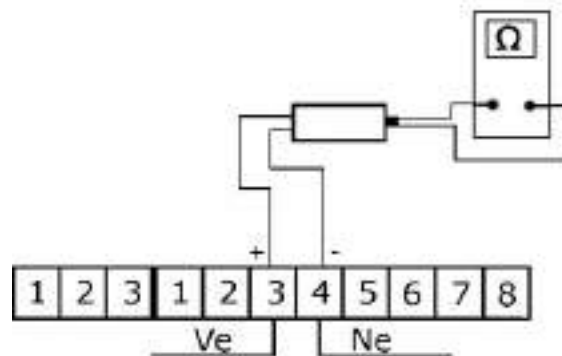
**N.B.**

THE MULTIMETER MUST BE SELECTED TO DETECT CONTINUOUS VOLTAGE.

Electric characteristic**Pick-Up voltage value**

Pick-Up voltage value: > 2 Volt

- H.V. coil

With the electronic starter and the HV coil connected to the system, measure the voltage of the coil primary during the start-up test with the voltage peak adaptor and by connecting the positive terminal to the ground lead and the negative terminal to the coil positive connector.

If non-conforming values are measured, replace the control unit.

THE POSITIVE TERMINAL OF THE HV COIL PRIMARY IS BLACK.

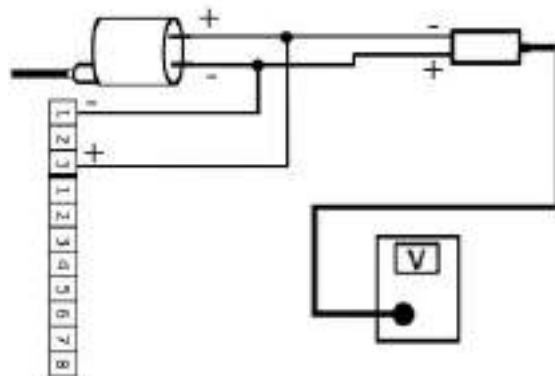
**Electric characteristic****High voltage coil voltage value**

High voltage coil voltage value: > 100 Volt

Stator check

- Using a tester, check the resistance between the brown-earth and black-earth terminal.

N.B.

VALUES ARE STATED AT AMBIENT TEMPERATURE. A CHECK WITH THE STATOR AT OPERATING TEMPERATURE LEADS TO VALUES HIGHER THAN THOSE STATED.

Electric characteristic

Stator : Brown-earth

~ 170 Ω (Pick-Up)

Stator : Black-earth

~ 1 Ω (Stator)

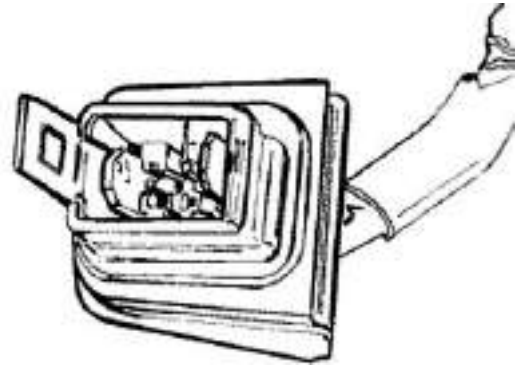

Voltage regulator check

A malfunction in the voltage regulator might cause the following problems depending on the type of fault:

- 1) Bulbs burned out (regulator in short circuit).
- 2) Malfunction of the lighting system and the electric starter (regulator interrupted).
- 3) Battery not recharging.
- 4) Turn indicators not working.

The regulator is earthed through the electrical system, so the regulator body does not earth the circuits inside the regulator.

There must be insulation between each regulator terminal and the regulator body (use the tester to check electric resistance).

2) LIGHTS AND STARTER NOT WORKING

Gain access to the voltage regulator by removing the plastic cover on the legshield; start the engine and keep running it at idle speed.

Connect the tester positive probe to terminal No.

1 (yellow cable) and the negative probe to terminal No. 2 (black cable); check if there is voltage.

If there is voltage, check that the light remote control and its excitation line, coming from the electronic starter (sky blue PIN 7 - purple PIN 3) work properly. Check the cable harness from the light switch to the remote control and whether the switch works properly .

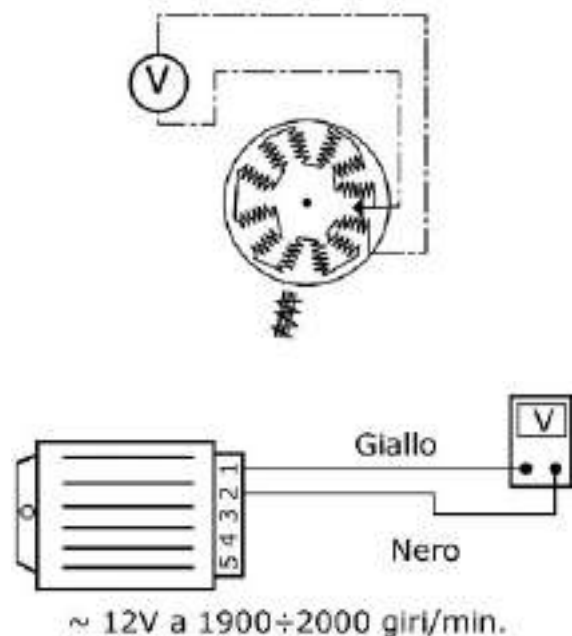

If no voltage is detected, try connecting the negative probe directly to earth; if voltage is detected with this operation, check the earth wiring of the regulator; otherwise, replace the regulator because it is failing.

As a last check, the voltage supplied by the stator can be measured:

- Disconnect the regulator connector and place a tester to detect alternating voltage between the Blue cable (4) and the ground connection (see figure).

- Voltage supplied at 2000 rpm must be about 25 ÷ 35V.

If no value is obtained even with this test, replace the regulator because it is obviously failing.

N.B.

TO MEASURE THE ABOVE VOLTAGE USE AN ANALOGUE TESTER THAT CAN MEASURE ALTERNATING VOLTAGES AND KEEP THE ENGINE AT IDLE TO HAVE AN ALTERNATING VOLTAGE OF A FREQUENCY AS CLOSE AS POSSIBLE TO 50HZ SO AS TO DETECT THE EFFICIENT VOLTAGE VALUE SUPPLIED BY THE REGULATOR (ABOUT 12V).

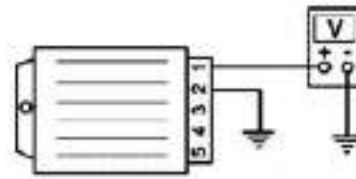

~ 12V a 1900÷2000 giri/min.

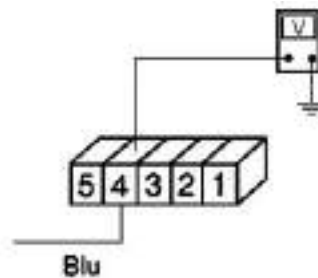

~ 25÷35V a 1900÷2000 giri/min.

Recharge system voltage check

3) BATTERY NOT RECHARGING

A failure in the direct current section of the voltage regulator may cause the following problems depending on the type of fault:

a) Protection fuse blows due to overvoltage (regulator in short circuit) and consequently the battery fails to recharge.

b) Battery fails to recharge (regulator interrupted).

Measures

a) Protection fuse blows (regulator in short circuit). Check that the cable harness going from the protection fuse to the key switch is not damaged, which may cause a short circuit to ground (thus preventing damaging the regulator).

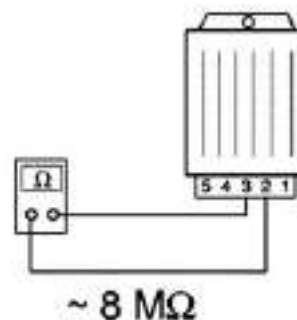

Afterwards measure the resistance between contact 3 (Orange) and contact 2 (Black) of the voltage regulator (with connector disconnected)

If the value measured is far from that indicated, replace the regulator because it is in short circuit.

b) Battery fails to recharge (regulator interrupted).

To check if there is any failure in the voltage regulator recharge section, first connect 2 testers to the battery (one to detect voltage and the other to detect current) as indicated in the second figure and follow the procedure below:

Start the engine (temporarily connect the red cable to the battery positive terminal in order to avoid damaging the device that measures current).

Check that there is a 13V voltage minimum (battery charged) and a recharge current of 1.5 ÷ 2A with the lighting system but the starter disabled. To disable the lighting system, remove the light remote control.

As the engine rpm increases, so do the current and the recharge voltage; with rpm over 4000 there must be a recharge current of about 4.5A; enabling both the lighting system and the starter, the stop light and if the horn is powered, current values \geq 5A and a voltage value of 14 ÷ 14.5V (regulator threshold voltage) can be found.

If values other than those above are detected, replace the regulator; contrariwise, check the cable harness and the connections.

Electric characteristic

Voltage regulator resistance

~ 8 M Ω

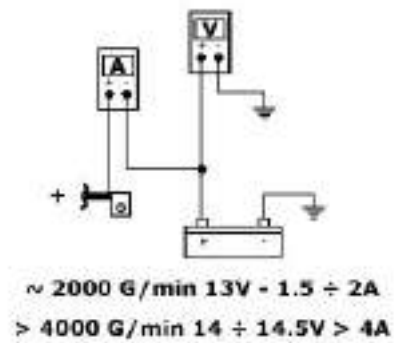

Turn signals system check

4) TURN INDICATORS NOT WORKING

If the turn indicators do not work, do the following:

- Remove the regulator connector and place the tester probes between the orange cable (3) and the black cable (2).
- Turn the key switch to ON and check that the battery is getting voltage. If no voltage is detected, repeat the test now between the orange cable and the ground lead. If there is no voltage even after this operation, check the cable harness and the contacts of the key switch and the battery. Conversely, if battery voltage is detected (black cable), check the regulator ground cable harness.
- If the above tests have positive results, jump contacts 5 (blue/black) and 3 (white) on the connector, set the key switch to ON and turn the turn indicator switch to the left and right to see when the lights are steadily on (as they are directly powered by the battery).

If even after this operation the turn indicators fail to turn on, check that the wiring is not damaged and the switch works properly. If these last two tests have a positive result, replace the regulator because it is certainly not functioning properly.

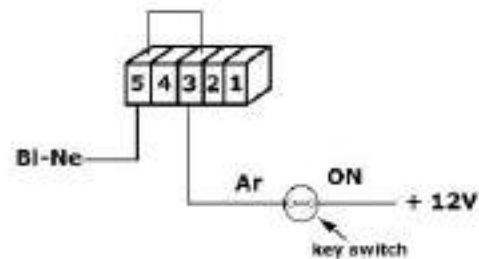
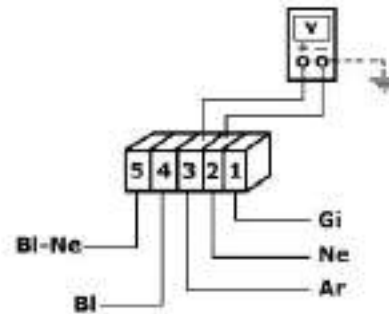

Specific tooling

020331Y Digital multimeter

Dry-charge battery

If available

WARNING

BATTERY ELECTROLYTE IS TOXIC AND IT MAY CAUSE SERIOUS BURNS. IT CONTAINS SULPHURIC ACID. AVOID CONTACT WITH YOUR EYES, SKIN AND CLOTHING. IF COMING INTO CONTACT WITH EYES OR SKIN, WASH ABUNDANTLY WITH WATER FOR APPROX. 15 MIN. AND SEEK IMMEDIATE MEDICAL ATTENTION.

IN THE EVENT OF ACCIDENTAL INGESTION OF THE LIQUID, IMMEDIATELY DRINK LARGE QUANTITIES OF WATER OR MILK, MAGNESIUM MILK, BATTERED EGG OR VEGETABLE OIL. SEEK IMMEDIATE MEDICAL ATTENTION.

BATTERIES PRODUCE EXPLOSIVE GASES; KEEP CLEAR OF NAKED FLAMES, SPARKS OR CIGARETTES; VENTILATE THE AREA WHEN RECHARGING INDOORS.

ALWAYS WEAR EYE PROTECTION WHEN WORKING IN THE PROXIMITY OF BATTERIES.

KEEP OUT OF THE REACH OF CHILDREN**Commissioning dry-charged batteries:**

- 1) - Remove the short closed tube and the plugs, then pour sulphuric acid into the cells using the type specified for batteries with a specific gravity of 1.26, corresponding to 30 Bé at a minimum temperature of 15°C. until the upper level is reached.
- 2) - Leave to rest for at least 2 hours; then, restore the level with sulphuric acid.
- 3) - Within the following 24 hours, recharge using the specific battery charger (single) or (multiple) at a density of about 1/10 of the battery nominal capacity until fully charged; check that the acid density is about 27, corresponding to 31 Be, and that these values are stabilised.
- 4) - Once the charge is over, level the acid (by adding **distilled water**). Close and clean carefully.
- 5) Once the above operations have been performed, install the battery on the vehicle ensuring that it is wired up properly.



- 1 Hold the vertical tube
- 2 Look at the level
- 3 The float must be freed

WARNING

- ONCE THE BATTERY HAS BEEN INSTALLED IN THE VEHICLE IT IS NECESSARY TO REPLACE THE SHORT TUBE (WITH CLOSED END) NEAR THE + POSITIVE TERMINAL WITH THE CORRESPONDING LONG TUBE (WITH OPEN END), THAT YOU FIND FITTED TO THE VEHICLE, TO ENSURE THAT THE GASES THAT FORM CAN ESCAPE PROPERLY.

Specific tooling

020333Y Single battery charger

020334Y Multiple battery charger

Battery maintenance

The battery is an electrical device which requires careful monitoring and careful maintenance. The maintenance rules are:

1) Check the level of the electrolyte

The electrolyte level must be checked frequently and must reach the upper level. Only use distilled water, to restore this level. If water topping is required too often, check the vehicle electrical system: the battery works overcharged and is subject to quick wear.

2) Load status check

After topping-up the electrolyte level, check its density using an appropriate densitometer (see figure). When the battery is charged, you should detect a density of 30 to 32 Bé corresponding to a specific weight of 1.26 to 1.28 at a temperature of no lower than 15° C.

A density reading of less than 20° Bé indicates that the battery is completely flat and it must therefore be recharged.

If the vehicle is not used for a given time (1 month or more) it will be necessary to periodically recharge the battery.

The battery runs down completely in the course of three months. If it is necessary to refit the battery in the vehicle, be careful not to reverse the connections, remembering that the ground wire (**black**) marked (-) must be connected to the **-negative** clamp while the other two **red** wires marked (+) must be connected to the clamp marked with the **+positive** sign.

3) Recharging the battery

Remove the battery from the vehicle disconnecting the negative terminal first.

Regular bench charging must be carried out with the specific battery charger, (single) or (multiple), setting the battery charger selector to the type of battery to be recharged. Connections to the power supply source must be implemented by connecting the corresponding poles (+ to+ and - to -).

4) Cleaning the battery

The battery should always be kept clean, especially on its top side, and the terminals should be coated with Vaseline.

CAUTION

NEVER USE FUSES WITH A CAPACITY HIGHER THAN THAT RECOMMENDED. THE USE OF A FUSE OF UNSUITABLE CAPACITY MAY RESULT IN SERIOUS DAMAGES TO THE WHOLE VEHICLE OR EVEN CAUSE A FIRE.

CAUTION

ORDINARY AND DRINKING WATER CONTAINS MINERAL SALTS THAT ARE HARMFUL FOR THE BATTERY. FOR THIS REASON, YOU MUST ONLY USE DISTILLED WATER.

CAUTION

TO ENSURE MAXIMUM PERFORMANCE THE BATTERY MUST BE CHARGED BEFORE USE. LACK OF PROPER CHARGING OF THE BATTERY BEFORE FIRST USE AT LOW ELECTROLYTE LEVEL, CAN LEAD TO PREMATURE BATTERY LIFE.

Specific tooling

020333Y Single battery charger

020334Y Multiple battery charger

Battery installation

If available

VRLA battery (valve-regulated lead-acid battery) Maintenance Free (MF)

WARNING

BATTERY ELECTROLYTE IS TOXIC AND IT MAY CAUSE SERIOUS BURNS. IT CONTAINS SULPHURIC ACID. AVOID CONTACT WITH YOUR EYES, SKIN AND CLOTHING. IF COMING INTO

**CONTACT WITH EYES OR SKIN, WASH ABUNDANTLY WITH WATER FOR APPROX. 15 MIN. AND SEEK IMMEDIATE MEDICAL ATTENTION.
IN THE EVENT OF ACCIDENTAL INGESTION OF THE LIQUID, IMMEDIATELY DRINK LARGE QUANTITIES OF WATER OR MILK, MAGNESIUM MILK, BATTERED EGG OR VEGETABLE OIL. SEEK IMMEDIATE MEDICAL ATTENTION.
BATTERIES PRODUCE EXPLOSIVE GASES; KEEP CLEAR OF NAKED FLAMES, SPARKS OR CIGARETTES; VENTILATE THE AREA WHEN RECHARGING INDOORS.
ALWAYS WEAR EYE PROTECTION WHEN WORKING IN THE PROXIMITY OF BATTERIES.
KEEP OUT OF THE REACH OF CHILDREN**

1) Battery preparation

Position the battery on a flat surface. Remove the adhesive sheet closing cells and proceed as quickly as possible to run the subsequent activation phases.



2) Electrolyte preparation.

Remove the container of the electrolyte from the pack. Remove and preserve cover strips from the container, in fact, the strip will later be used as a closing cover.

Note: Do not pierce the sealing of the container or the container itself because inside there is sulfuric acid.



3) Procedure for filling the battery with acid.

Position the electrolyte container upside down with the six areas sealed in line with the six battery filler holes. Push the container down with enough force to break the seals. The electrolyte should start to flow inside the battery.

Note: Do not tilt the container to prevent the flow of electrolyte from pausing or stopping.



4) Control the flow of electrolyte

Make sure air bubbles are rising from all six filling holes. Leave the container in this position for 20 minutes or more.

Note: If there are no air bubbles coming out of the filling holes, lightly tap the bottom of the container two or three times. Do not remove the container from the battery.

5) Take out the container.

Make sure all the electrolyte in the battery is drained. Gently tap the bottom of the container if electrolyte remains in the container. Now, gently pull the container out from the battery, only do this when the container is completely empty, and proceed immediately to the next point.

6) Battery closing.

Insert the airtight cover strips into the filling holes. Press horizontally with both hands and make sure that the strip is levelled with the top part of the battery.

Note: To do this, do not use sharp objects that could damage the closing strip, use gloves to protect your hands and do not bring your face close to the battery.

The filling process is now complete.

Do not remove the strip of caps under any circumstances, do not add water or electrolyte.

Place the battery down for 1 to 2 hours prior to the charging from the battery.

7) Recharging the new battery

With the above-mentioned procedure, the battery will have gained around 70% - 75% of its total electrical capacity. Before installing the battery on the vehicle, it must be fully charged and then must be recharged.

If the battery is to be installed on the vehicle prior to this pre-charged one, the battery will not be able to exceed 75% charge without jeopardising its useful life on vehicle.

The dry charge battery MF like the completely loaded YTX, must have a no-load voltage between 12.8 - 13.15 V Bring the battery to full charge, using the 020648Y battery charger:

- a - select the type of battery with the red switch on the left of the panel battery charger panel
- b - select NEW on the yellow timer
- c - connect the clamps of the battery charger to the battery poles (black clamp to negative pole (-) and red clamp to positive pole (+)).



d - Press the red button, as shown in figure.



e - Press the "MF" black button to activate the battery recharge **Maintenance Free** as shown in figure.



f - Check the ignition of the green LED indicated with a red arrow in figure.



g - The activation cycle of the new battery lasts for 30 minutes after the ignition of the recharge LED has taken place



h - Disconnect the clamps from the battery and check the voltage, if voltages are detected of less than 12.8 V, proceed with a new recharge of the battery starting from point c of the recharge procedure of **the new battery**, otherwise go to point i



i - The battery is now completely activated, disconnect the battery charger from the fuel supply grid, disconnect the clamps from the battery and proceed to fitting the battery on the vehicle.

Connectors

ELECTRONIC STARTER

SECTION "A"

1. HV COIL CONTROL
2. KEY SWITCH CONTACTS TO GROUND
3. HV COIL POSITIVE

SECTION "B"

1. KEY POSITIVE
2. STARTER POWER SUPPLY
3. PICK UP SIGNAL
4. GROUND
5. SOLENOID VALVE
6. NTC TEMPERATURE SENSOR
7. LIGHT REMOTE CONTROL
8. DIAGNOSIS SOCKET

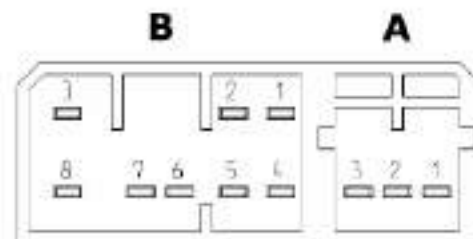

VOLTAGE REGULATOR

1. LIGHTING SYSTEM POWER SUPPLY (alternating)
2. GROUND
3. BATTERY POSITIVE
4. FROM FLYWHEEL (alternating)
5. TURN INDICATORS

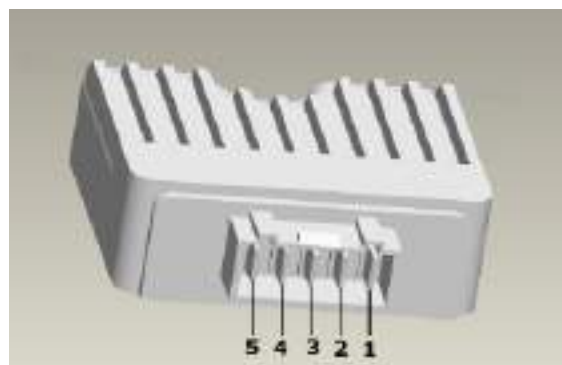

INDEX OF TOPICS

ENGINE FROM VEHICLE

ENG VE

Exhaust assy. Removal

- Remove the 2 fixing nuts from the manifold to the head



- Undo the 2 screws fixing the silencer to the housing; then remove the whole muffler paying attention to the interference between its supporting bracket and the cooling cover.

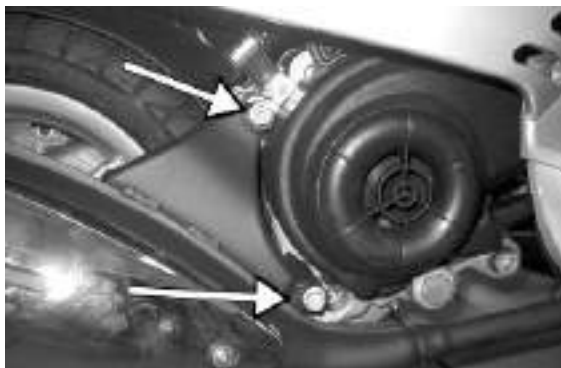

Removal of the engine from the vehicle

Removing the engine from the chassis

- Disconnect the battery.
- Remove the muffler assembly.
- Remove the rear wheel.
- Remove the rear brake mechanical transmission.
- Disconnect the electric terminals.
- Remove the throttle grip transmission.
- Disconnect the tubing (petrol-vacuum operated cock control).
- Disconnect the swinging arm on the engine side
- Disconnect the rear shock absorber lower clamping

WARNING

Handle fuel with care.

CAUTION

When installing the battery, first attach the positive cable and then the negative cable.

WARNING

Wear safety goggles when using hitting tools.

INDEX OF TOPICS

ENGINE

ENG

Automatic transmission

Transmission cover

- Remove the 12 fixing screws.
- Remove the oil filling cap and then slide out the cover.

If this operation is carried out directly on the vehicle, it is necessary to remove the transmission cooling coupling and the air filter housing retainers.

N.B.

USE A MALLET ON THE APPROPRIATE COUPLINGS TO REMOVE THE COVER.

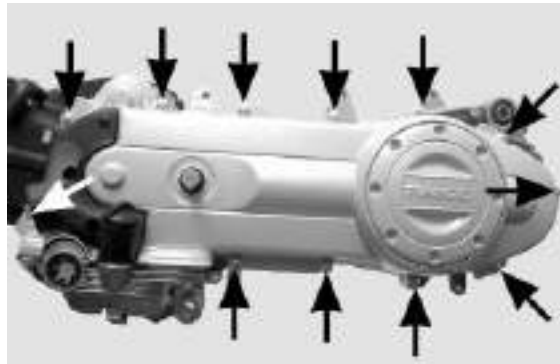

Kickstart

- To remove the start up pinion push the starter lever to facilitate extracting the pinion.
- Remove the kick-start screw and lever.
- Remove the Seeger ring and the washer indicated in the figure.
- Pull out the toothed sector.

WARNING

THE SECTOR KEEPS THE SPRING SET, BE CAREFUL SO AS NOT TO CAUSE ANY ACCIDENTS



Air duct

- To remove the intake throat on the transmission cover, just remove the three fixing screws indicated in the figure.

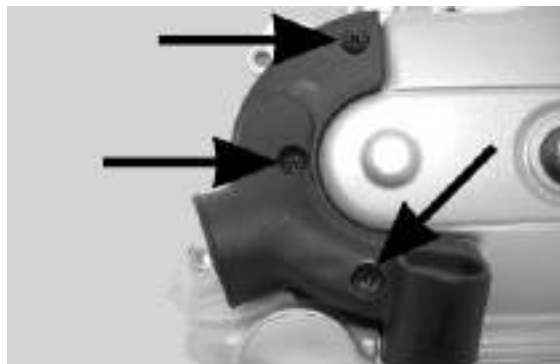

Removing the driven pulley shaft bearing

- Slightly heat the crankshaft from the inside side to avoid damaging the coated surface and use the driven pulley shaft or a pin of the same diameter to remove the bearing.

N.B.

IN CASE OF DIFFICULTY A STANDARD 8MM-INSIDE DIAMETER EXTRACTOR CAN BE USED.



Refitting the driven pulley shaft bearing

Refit the bearing with the aid of a bushing with the same diameter as the external plate of the bearing after slightly heating the crankcase from the inside.

N.B.

WHEN REFITTING, ALWAYS REPLACE THE BEARING WITH A NEW ONE.

CAUTION

WHEN REMOVING/REFITTING THE BEARING, TAKE CARE NOT TO DAMAGE THE COVER PAINTED SURFACE.

Removing the driven pulley

- Lock the clutch housing with the specific tool.
- Remove the nut, the clutch housing and the whole of the driven pulley assembly.

N.B.

THE UNIT CAN ALSO BE REMOVED WITH THE DRIVING PULLEY MOUNTED.

Specific tooling

020565Y Flywheel lock calliper spanner



Inspecting the clutch drum

- Check that the clutch housing is not worn or damaged.
- Measure the inner diameter of the clutch housing.

Characteristic

clutch housing diameter/standard value

Ø 107+0.2 +0 mm

clutch housing diameter/max. value allowed after use

Ø 107.5 mm

Eccentricity measured /max.

0.20 mm



Removing the clutch

- Equip the tool with long pins screwed into position «A» from the outside, insert the entire driven pulley in the tool and have the central screw make contact.

CAUTION

THE TOOL WILL BE DEFORMED IF THE CENTRAL SCREW IS TIGHTENED UP TOO FAR.



- Using a 34 mm socket wrench remove the clutch locking nut.
- Loosen the central screw by undoing spring of the driven pulley unit
- Separate the components.

Specific tooling

020444Y Tool for fitting/ removing the driven pulley clutch



Inspecting the clutch

- Check the thickness of the clutch mass friction material.
- The masses must not show traces of lubricants; otherwise, check the driven pulley unit seals.

N.B.

UPON RUNNING-IN, THE MASSES MUST EXHIBIT A CENTRAL FAYING SURFACE AND MUST NOT BE DIFFERENT FROM ONE ANOTHER. VARIOUS CONDITIONS CAN CAUSE THE CLUTCH TO TEAR.

CAUTION

DO NOT OPEN THE MASSES USING TOOLS TO PREVENT A VARIATION IN THE RETURN SPRING LOAD.



Characteristic

Check minimum thickness

1 mm

Pin retaining collar

- Remove the collar with the aid of 2 screwdrivers.



- Remove the three guide pins and the mobile half pulley.



Removing the driven half-pulley bearing

- Remove the roller bearing with the special extractor inserted from the bottom of the fixed half-pulley.

CAUTION

POSITION THE HOLDING EDGE OF THE EXTRACTION PLIERS BETWEEN THE END OF THE BEARING AND THE BUILT IN SEAL RING.

Specific tooling

001467Y029 Bell for bearings, O.D. 38 mm



- Remove the ball bearing retention snap ring.
- Expel the ball bearing from the side of the clutch housing by means of the special tool.

N.B.

PROPERLY SUPPORT THE HALF-PULLEY SO AS NOT TO DEFORM THE SLIDING SURFACE OF THE DRIVE BELT

Specific tooling

020376Y Adaptor handle

020363Y 20-mm guide



Inspecting the driven fixed half-pulley

- Check that there are no signs of wear on the work surface of the belt. If there are, replace the half-pulley..
- Make sure the bearings do not show signs of unusual wear.
- Measure the external diameter of the pulley bushing.



Characteristic

Stationary driven half-pulley/Standard diameter

Ø 33.965 to 33.985 mm

Stationary driven half-pulley / Minimum diameter admitted after use

Ø 33.96 mm

Inspecting the driven sliding half-pulley

- Remove the 2 inner sealing rings and the two O-rings.
- Measure the inside diameter of the mobile half-pulley bushing.

Characteristic

Mobile driven half-pulley/ Maximum diameter allowed

Ø 34.08 mm



- Check the belt contact surfaces.
- Insert the new oil seal and O-rings on the mobile half-pulley.
- Fitting the half-pulley on the bushing.

Recommended products

AGIP GREASE SM 2 Grease for the C-ring of the tone wheel

Soap-based lithium grease containing NLGI 2 Molybdenum disulphide; ISO-L-XBCHB2, DIN KF2K-20



- Make sure the pins and collar are not worn, reassemble the pins and collar.
- Use a greaser with a curved spout to lubricate the driven pulley unit with around 6 g of grease. This operation must be done through one of the holes inside the bushing until grease comes out of the opposite hole. This procedure is necessary to prevent the presence of grease beyond the O-ring.

Recommended products

AGIP GREASE SM 2 Grease for the C-ring of the tone wheel

Soap-based lithium grease containing NLGI 2 Molybdenum disulphide; ISO-L-XBCHB2, DIN KF2K-20

Refitting the driven half-pulley bearing

- Fit a new ball bearing with the specific tool.
- Fit the ball bearing retention snap ring.
- Fit the new roller bearing with the wording visible from the outside.

CAUTION

PROPERLY SUPPORT THE HALF-PULLEY TO PREVENT DAMAGE TO THE THREADED END WHILE THE BEARINGS ARE BEING FITTED.

Specific tooling

020376Y Adaptor handle



020456Y Ø 24 mm adaptor

020362Y 12 mm guide

020171Y Punch for Ø 17 mm roller bearing

Inspecting the clutch spring

- Check that the contrast spring of the driven pulley does not show signs of deformation
- Measure the free length of the spring

Characteristic

Standard length

118 mm

Minimum length allowed after use

XXXX



- Check the thickness of the clutch mass friction material.
- The masses must not show traces of lubricants; otherwise, check the driven pulley unit.

N.B.

UPON RUNNING-IN, THE MASSES MUST EXHIBIT A CENTRAL CONTACT SURFACE AND MUST NOT BE DIFFERENT FROM ONE ANOTHER. VARIOUS CONDITIONS CAN CAUSE THE CLUTCH TO TEAR.

CAUTION

DO NOT OPEN THE MASSES USING TOOLS SO AS TO PREVENT A VARIATION IN THE RETURN SPRING LOAD.



Characteristic

Minimum thickness permitted:

1 mm

Refitting the clutch

- Preassemble the driven pulley group with spring, sheath and clutch.
- Position the spring with the sheath
- Insert the components in the tool and preload the spring being careful not to damage the plastic sheath and the end of the threaded shank.



- Reassemble the nut securing the clutch and tighten to the prescribed torque.

CAUTION

SO AS NOT TO DAMAGE THE CLUTCH NUT USE A SOCKET WRENCH WITH SMALL CHAMFER.

CAUTION

POSITION THE NON-CHAMFERED SURFACES OF THE NUT IN CONTACT WITH THE CLUTCH

Locking torques (N*m)

Nut locking clutch unit on pulley 55 to 60 Nm



Refitting the driven pulley

- Refit the driven pulley assembly, the clutch bell and the nut, using the specific tool.

Specific tooling

020565Y Flywheel lock calliper spanner

Locking torques (N*m)

Driven pulley shaft nut 40 to 44 Nm



Drive-belt

- Make sure the drive belt is not damaged and does not have cracks in the toothed grooves.

- Check the width of the belt.

Characteristic

Transmission belt/Minimum width

17.5 mm

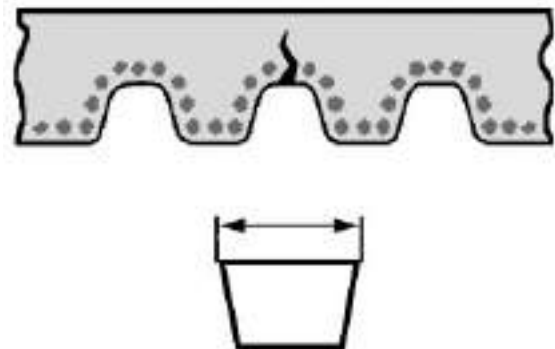

Removing the driving pulley

- Lock the driving pulley using the appropriate tool.
- Remove the central nut with the related washer, then remove the drive and the plastic fan.
- Remove the stationary half-pulley.



- Remove the belt, washer and remove the mobile half-pulley with its bushing, being careful that the rollers and contrast plate fitted loosely on it do not come off.

Specific tooling

020451Y Starting ring gear lock

Inspecting the rollers case

- 1) Check that the bushing and the sliding rings of the mobile pulley do not show signs of scoring or deformation.
- 2) Check the roller running tracks on the contact pulley; there must not be signs of wear and check the condition of the contact surface of the belt on the half-pulleys (mobile and stationary).
- 3) Check that the rollers do not show signs of marked facetting on the sliding surface and that the metallic insert does not come out of the plastic shell borders.
- 4) Check the integrity of the sliding shoes of the contact plate.

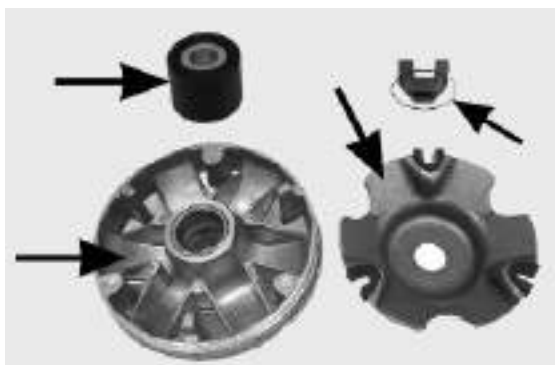

- Check that the internal bushing shown in the figure is not abnormally worn and measure inside diameter «A».
- Measure outside diameter «B» of the pulley sliding bushing shown in the figure.

CAUTION

DO NOT LUBRICATE OR CLEAN THE BUSHING.

Characteristic

Driving pulley / Maximum diameter:

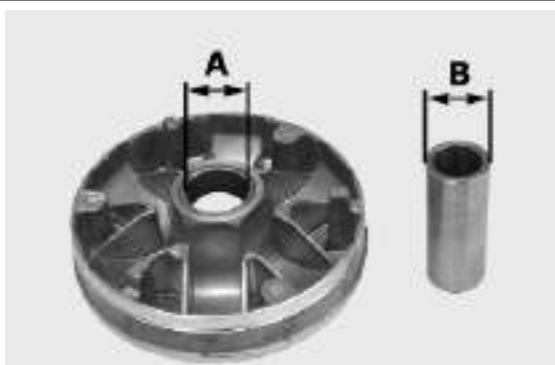

20.12 mm

Driving pulley/ Standard diameter:

20.021 mm

Driving pulley bushing/ Diameter maximum:

XXX mm

Driving pulley bushing/ Standard diameter:

20 -0.020/-0.041 mm

Refitting the driving pulley

- Manually move the movable driven half-pulley away by pulling it towards the clutch unit and insert the belt observing the direction of rotation of the first fitting.

N.B.

IT IS GOOD PRACTICE ALWAYS TO FIT THE BELT SO THAT THE WORDS CAN BE READ IN CASE IT DOES NOT SHOW A FITTING SIDE.



- Refit the components of the assembly (roller container assembly with bushing, limiting washer, stationary half-pulley, cooling fan belt with drive, washer and nut).

- With the specific tool, tighten the lock nut to 20 Nm and then perform a final 90° locking in order to prevent the rotation of the driving pulley.

N.B.

REPLACE THE NUT WITH A NEW ONE AT EVERY REFIT CAUTION

UPON FITTING THE DRIVING PULLEY UNIT IT IS OF UTMOST IMPORTANCE THAT THE BELT IS FREE INSIDE IN ORDER TO AVOID WRONG TIGHTENING AND CONSEQUENTLY DAMAGING THE CRANKSHAFT KNURLING.



Specific tooling

020451Y Starting ring gear lock

Locking torques (N*m)

Crankshaft pulley nut 18 to 20 + 90° Nm

Refitting the transmission cover

- Check the following for wear: toothed section, toothed section shaft, cover seat bushing, pinion shaft and its seating in the crankcase and the return spring.
- Remove the damaged components.
- Grease the spring.
- Remove the toothed sector and load the spring with an appropriate tool.
- Refit the washer, the Seeger and the Kick-start lever.

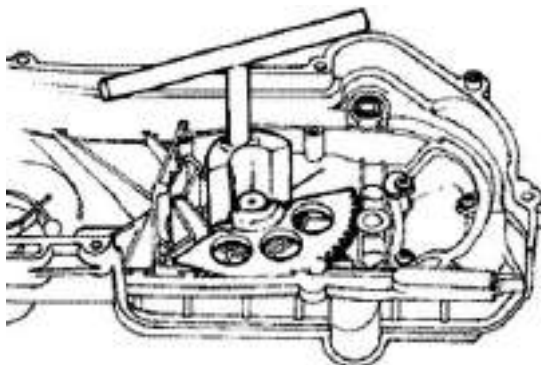

Recommended products

AGIP GREASE MU3 Grease for odometer transmission gear case

Soap-based lithium grease with NLGI 3; ISO-L-XBCHA3, DIN K3K-20

- Insert the pinion in its seating by pushing the starter lever.
- Fit the intake throat and tighten the 3 screws.

-Make sure the oil sump presents centring dowels and sealing gaskets.

- Replace the cover tightening the 12 screws to the prescribed torque.

-Refit the oil filling cap.

Locking torques (N*m)

Transmission cover screws 11 to 13 Nm

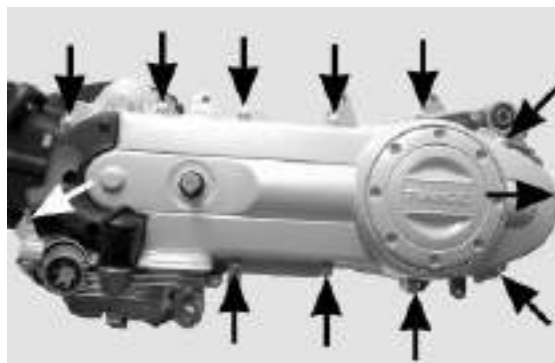

End gear

Removing the hub cover

- Remove the transmission cover
- Remove the clutch assembly
- Discharge the rear hub oil.
- Remove the 5 screws indicated in the figure.
- Remove the hub cover with driven pulley shaft.

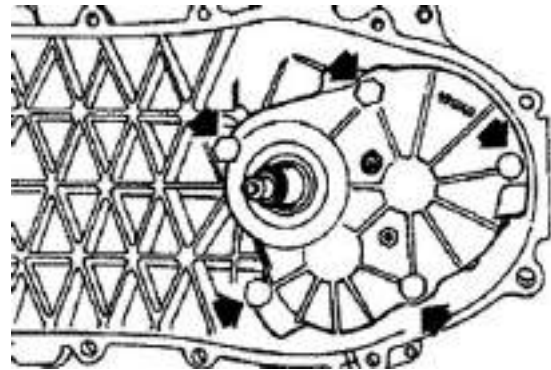

See also

[Refitting the clutch](#)

Removing the wheel axle

- Remove the intermediate gear and the complete gear wheel axle.
- When removing the intermediate gear pay attention to the various shim adjustments.

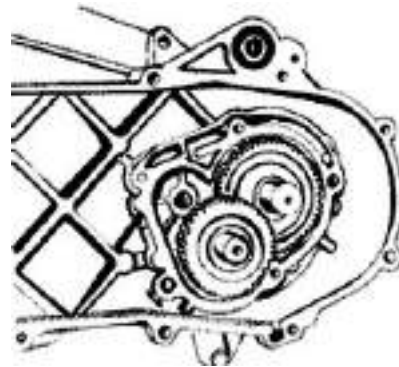

Removing the wheel axle bearings

- Remove the oil seal and the Seeger ring.
- Remove the bearing by pushing from the outside towards the inside of the gear compartment, using the appropriate punch.

Specific tooling

020363Y 20-mm guide

020376Y Adaptor handle

020358Y 37x40-mm Adaptor

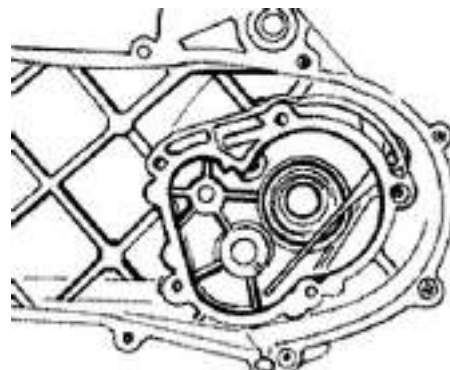

Removing the driven pulley shaft bearing

- Remove the Seeger ring inside the cover.
- Remove the oil seal from the outside.
- Remove the centring dowels and position the cover on a plane.
- Position the special tool on the internal track of the bearing and remove said bearing with the aid of a press.



Specific tooling

020452Y Tube for removing and refitting the driven pulley shaft

- Position the special tube on the internal raceway of the bearing and from the shaft toothed side as indicated in the figure. Expel the driven pulley shaft with the aid of a press.



Specific tooling

020452Y Tube for removing and refitting the driven pulley shaft

Inspecting the hub shaft

- Check the three shafts for wear or distortion of the toothed surfaces, the bearing housings, and the oil seal housings.
- If faults are found, replace the damaged components.
- Check capacity (A) of the transmission gear (wear, deformations, etc.)
- Check the pulley shaft seating: Superficial wear (B) may indicate irregularities in the crankcase seatings or in the pulley shaft capacities



Inspecting the hub cover

- Check that the fitting surface is not dented or distorted.
- If faults are found, replace the hub cover.

Refitting the driven pulley shaft bearing

- Support the inner track of the bearing from the outside of the hub cover with the specific tool positioned under the press and insert the driven pulley axle.
- Refit the oil seal flush with the cover.

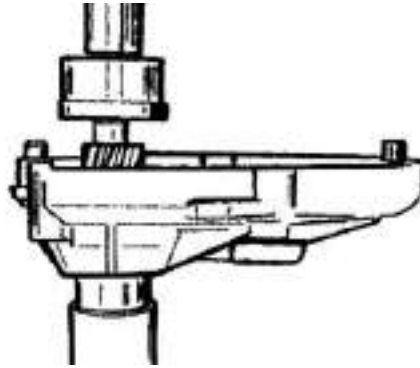

Specific tooling

020452Y Tube for removing and refitting the driven pulley shaft

- Heat the hub cover and insert the bearing with the specific punch.
- Fit the snap ring with the concave or radial part on the bearing side.

N.B.

FIT THE BALL BEARING WITH THE SHIELD FACING THE OIL SEAL.

Specific tooling

020151Y Air heater

020376Y Adaptor handle

020439Y 17-mm guide

020358Y 37x40-mm Adaptor

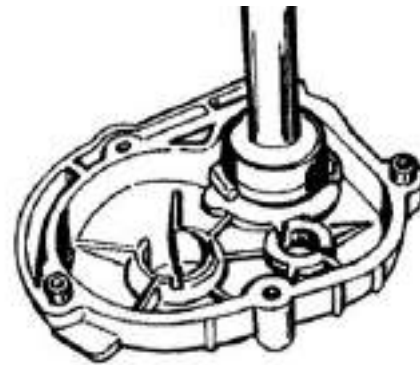

Refitting the wheel axle bearing

- Heat the half crankcase on the transmission side using a thermal gun.
- After lubricating its outer strip, insert the bearing with the special adapter with the aid of a hammer.
- Refit the Seeger ring and the oil seal using the 42 x 47 mm adapter and the handle.

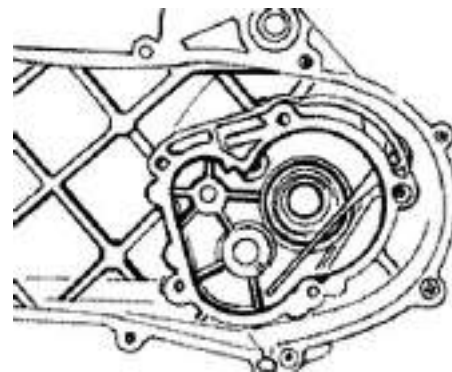

Specific tooling

020151Y Air heater

020376Y Adaptor handle

020363Y 20-mm guide

020359Y 42x47-mm Adaptor

Refitting the ub cover

- Refit the whole wheel axle.
- Refit the intermediate gear paying attention to the two shim washers.
- Apply LOCTITE 510 for surfaces to the hub covers and refit the same with driven pulley shaft.
- Refit the 5 screws and tighten them to the specified torque.

N.B.

CLEAN THE CONTACT SURFACES OF THE HUB COVER AND THE HALF CRANKCASE OF RESIDUE FROM PREVIOUS GASKETS BEFORE APPLYING A NEW ONE.

Locking torques (N*m)

Locking torque: 11 to 13 Nm

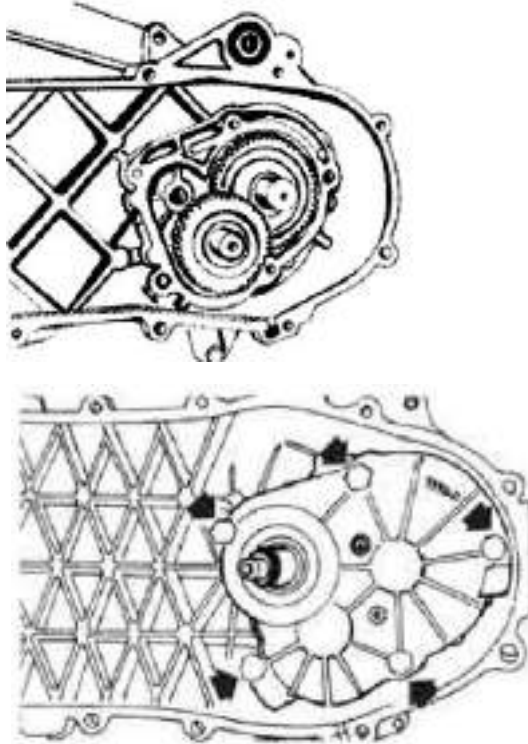

Flywheel cover

Cooling hood

- Remove the manifold and the carburettor undoing the 2 fixing screws on the head
- Remove the fastening clamp of the secondary air pipe and disconnect it
- Remove the 4 front coupling screws (1 of them is a knob) and the side fixing screw at the crankcase base.
- Remove the 4 side screws
- Extract the 3 covers - Remove the cover sealing gaskets on the head
- For refitting, repeat the removal steps but in reverse order

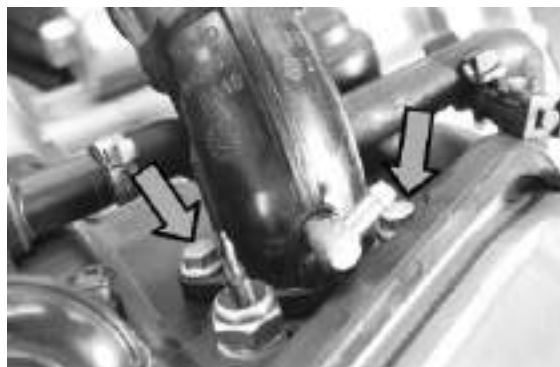

CAUTION

TAKE CARE TO CORRECTLY POSITION THE FLYWHEEL CONNECTOR.

N.B.

WHEN REFITTING THE COVER, TAKE CARE NOT TO DAMAGE THE STATOR WIRING.



Cooling fan

- Remove the cooling fan by undoing the 3 screws fixing it to the rotor
- When refitting the fan, pay attention that the screw holes in the fan and the rotor coincide, then tighten screws at the specified torque.



Removing the stator

- Remove the 2 Pick-Up screws and the 2 stator fixing screws indicated in the figure.
- Remove the stator and its wiring.

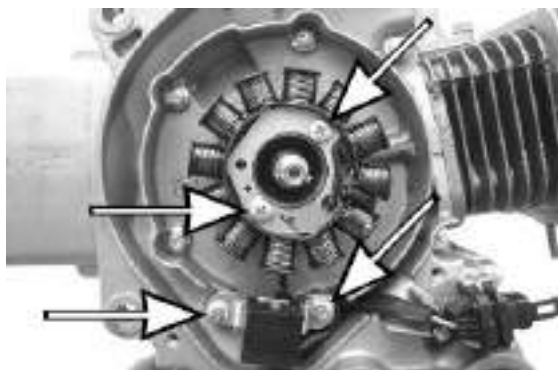

Refitting the stator

- Refit the stator and flywheel carrying out the removal procedure in reverse, tightening the retainers to the specified torque.

N.B.

THE PICK-UP CABLE MUST BE POSITIONED ADHERING TO THE FUSION TONGUE ON THE CRANKSHAFT IN SUCH A WAY AS TO AVOID BEING CRUSHED BY THE FAN COVER ASSEMBLY.

Locking torques (N*m)

Pick-up screws 3 to 4 Stator screws 3 to 4

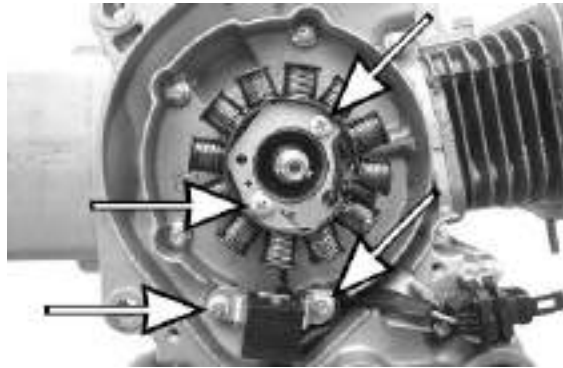

Flywheel and starting

Removing the starter motor

- Undo the screw on the power positive contact and disconnect the cable
- Undo the 2 screws fixing the starter motor to the crankcase and recover the power wiring.

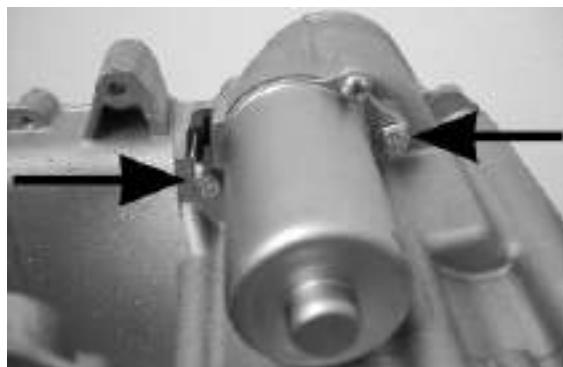

Removing the flywheel magneto

- Lock the rotation of the flywheel using the calliper spanner.
- Remove the nut.

CAUTION

THE USE OF A CALLIPER SPANNER OTHER THAN THE ONE SUPPLIED COULD DAMAGE THE STATOR COILS



-
- Extract the flywheel with the extractor.

Specific tooling

020565Y Flywheel lock calliper spanner

020162Y Flywheel extractor



Inspecting the flywheel components

- Check that the flywheel internal magnets are in good conditions.
- Check that the flywheel splines exhibit no loosening.
- Check there are no deformations that may cause rubbing on the stator and the Pick-Up.
- Check that the stator winding, its ferromagnetic support and the pick-up are in good conditions.



Starter gear rim

- Check the tothing is level and in good conditions



Intermediate gear

- Check that the keying tothing on the crown and the starter motor are in good conditions.
- Check that the Bendix opens and returns adequately.



Refitting the flywheel magneto

- Refit the stator and the pick-up being careful to pass the wiring through the appropriate crankcase couplings.
- Refit the flywheel to the crankshaft being careful to respect the keying, then lock rotation with the specific tool and tighten the nut to the prescribed torque.



N.B.

A VARIATION OF THE AIR GAP DISTANCE CAN LEAD TO A VARIATION IN THE IGNITION ADVANCE SUCH AS TO CAUSE PINGING, KNOCKING ETC.

Specific tooling

020565Y Flywheel lock calliper spanner

Locking torques (N*m)

Flywheel nut 52 to 58



Refitting the starter motor

- Install the starter motor in its seating in the crank-case.
- Tighten the screw on the head side but do not lock it, screw the second screw inserting the earth cable (black), then tighten the 2 screws at the prescribed torque.
- Tighten the locking screw of the positive cable (red) on the side contact.



N.B.

REFIT THE REMAINING PARTS AS DESCRIBED IN THE CYLINDER HEAD, TIMING, LUBRICATION, FLYWHEEL AND TRANSMISSION CHAPTERS.

Locking torques (N*m)

Starter screws 11 to 13

Cylinder assy. and timing system

Removing the rocker-arms cover

- Remove the cooling covers
- Remove the 4 retainers of the tappet cover
- Remove the cover and the O-ring
- Remove the 3 screws and then remove the Blow-by cover
- Clean the nozzle labyrinth and the membrane (replace it, if necessary), then remove the cover unit.



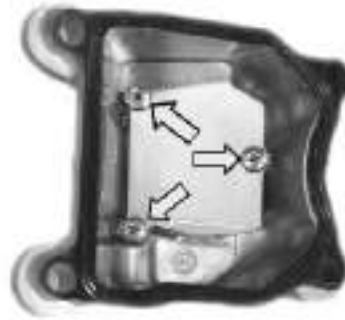

Removing the timing system drive

- Temporarily loosen the tensioner central screw and remove it together with the spring.
- Unscrew the 2 retainers indicated in the figure and remove the chain tightener support being careful to recover the sealing gasket.

N.B.

SHOULD THE GASKET NOT BE IN GOOD CONDITIONS, REPLACE IT AFTER CAREFULLY CLEANING THE FAYING SURFACE IN ORDER TO AVOID ENGINE OIL LEAKS

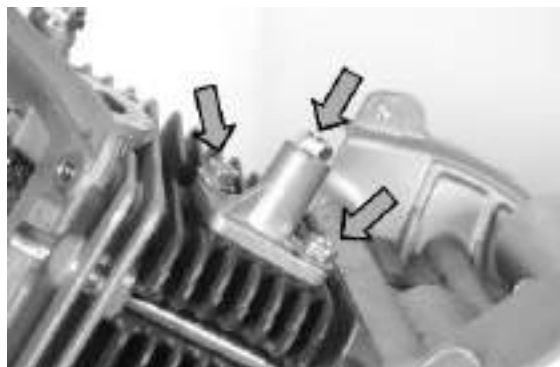

- Remove the driving pulley
- Remove the oil pump chain
- Remove the tappet cover
- Remove the central screw and the Belleville washer indicated in the figure and lock the camshaft crown with the specific tool.

N.B.

TO FACILITATE REMOVING THE HEAD COMPONENTS, SET THE CRANKSHAFT TO THE TIMING POINT (TDC OF THE COMPRESSION END).



Specific tooling

020565Y Flywheel lock calliper spanner

- Remove the camshaft control pulley and the washer below.
- Remove the pinion of the crankshaft timing control
- To remove the chain lower guiding pad, remove the head by pulling it upwards

N.B.

IT IS ADVISABLE TO MARK THE CHAIN IN ORDER TO ENSURE THAT THE DIRECTION OF ROTATION IS MAINTAINED.

See also

- [Removing the rocker-arms cover Removal](#)
- [Removing the driving pulley](#)

Removing the cam shaft

- Remove the limit screw of the rocking lever pins shown in the figure.
- Remove the Seeger ring retaining the camshaft bearing.
- Remove pins and rocking levers.
- Remove the calibrated pads

N.B.

MARK THE ASSEMBLY POSITION OF THE ROCKING LEVERS IN ORDER TO AVOID MISPLACING THE INTAKE AND DISCHARGE ENDS.



- Remove the entire camshaft with bearing using the specific tool shown in the figure.
- Take out the camshaft bearing with the aid of the specific tool, being careful to mount a screw on the camshaft in order to protect its thread.

N.B.

IF A BEARING SEPARATES FROM THE CAMSHAFT, IT IS ESSENTIAL TO FIT A NEW BEAR.



Specific tooling

020450Y Camshaft fitting/removal tool

004499Y Camshaft bearing extractor

004499Y001 Bearing extractor bell

004499Y002 Bearing extractor screw

004499Y006 Bearing extractor ring

004499Y027 Bearing extractor part

Removing the cylinder head

- Remove the cooling covers, the timing control, the camshaft and the rocking levers.
- Remove the spark plug.
- Remove the 2 side fixings shown in the figure.
- Loosen the 4 head-cylinder fastening nuts in two or three stages and in criss-cross fashion.
- Remove the head, the two alignment dowels and the gasket.

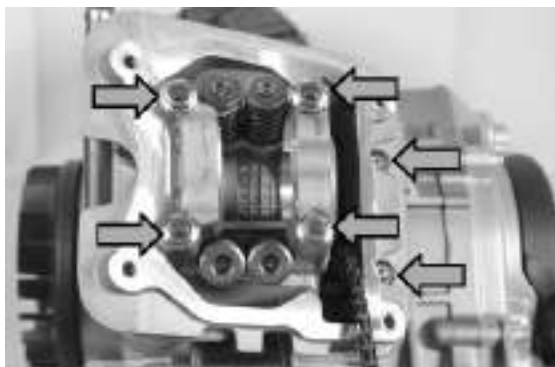
**N.B.**

IF NEEDED, THE HEAD MAY BE REMOVED WITH THE CAMSHAFT, PINS AND ROCKING LEVERS WITHOUT REMOVING THE DRIVING PULLEY UNIT. REMEMBER TO HOLD THE TIMING CHAIN WITH A PIECE OF METAL CABLE AND TO ADJUST THE CHAIN TIGHTENER UPON RE-FITTING.

Removing the valves

- Using the specific tool fitted with the part shown in the figure, remove cotters, caps and valve springs.



- Remove the oil seals with the appropriate tool.

Specific tooling

020431Y Valve oil seal extractor

020382Y Valve cotters equipped with part 012 removal tool



Removing the cylinder - piston assy.

- Remove the cylinder paying attention to the 2 cylinder centring dowels in the housing.

- Remove the cylinder base gasket.

To avoid damaging the piston, keep it fixed while removing the cylinder.



- Remove the two stop rings, the wrist pin and the piston.

- Remove the 3 piston rings from the piston.

N.B.

BE CAREFUL NOT TO DAMAGE THE PISTON RINGS DURING REMOVAL.



Inspecting the small end

- Measure the internal diameter of the connecting rod small end using an internal micrometer.

N.B.

IF THE DIAMETER OF THE CONNECTING ROD SMALL END EXCEEDS THE MAXIMUM DIAMETER ALLOWED, SHOWS SIGNS OF WEAR OR OVERHEATING REPLACE THE CRANKSHAFT AS DESCRIBED IN THE "CRANKCASE AND CRANKSHAFT" CHAPTER".

Characteristic

Max. diameter admitted: check the small end

13.030 mm

Standard diameter: check the small end

13 +0.025+0.015mm



Inspecting the wrist pin

- Measure the outer diameter of the gudgeon pin.

Characteristic

Standard diameter: gudgeon pin

13 -0 -0.004mm

Minimum admissible diameter gudgeon pin

12.990 mm

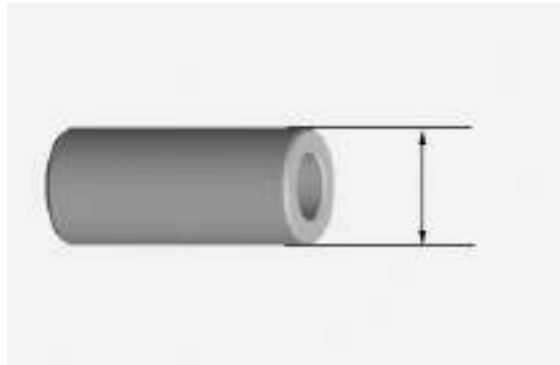

Inspecting the piston

- Measure the diameter of the bearings on the piston.

Characteristic

Pin seat diameter

13 +0.005 + 0.010 mm



- Carefully clean the seal housings.
- Measure the coupling clearance between the sealing rings and the grooves using suitable sensors, as shown in the diagram.
- If the clearance is greater than that indicated in the table, replace the piston.

N.B.

MEASURE THE CLEARANCE BY INSERTING THE BLADE OF THE FEELER THICKNESS GAUGE FROM THE SECOND SEAL SIDE.

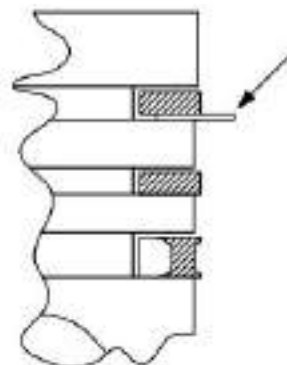

Fitting clearance

Top piston ring - standard coupling clearance 0.03 to 0.065 mm **Top piston ring - maximum clearance allowed after use** 0.07 mm **Middle piston ring - standard coupling clearance** 0.02 to 0.055 mm **Middle piston ring - maximum clearance allowed after use** 0.06 mm **oil scraper ring - standard coupling clearance** 0.04 to 0.16 mm **oil scraper ring - maximum clearance allowed after use** 0.17 mm

Inspecting the cylinder

- Using a bore meter, measure the inner cylinder diameter at three different points according to the directions shown in the figure.
- Check that the coupling surface with the head is not worn or misshapen.
- Pistons and cylinders are classified into categories based on their diameter. The coupling is carried out in pairs (A-A, B-B, C-C, D-D).

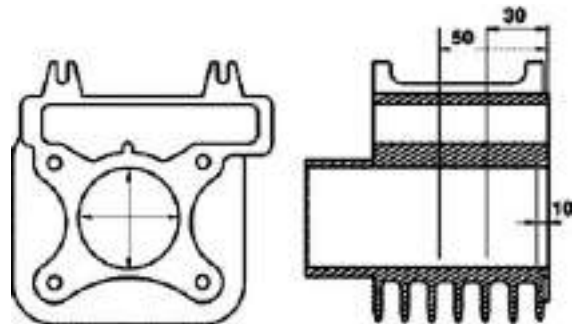

Characteristic

Maximum allowable run-out:

0.05 mm



Inspecting the piston rings

- Alternately insert the three sealing rings into the cylinder, in the area where it retains its original diameter. Using the piston, insert the rings perpendicularly to the cylinder axis.
- Measure the opening, see figure, of the sealing rings using a thickness gauge.
- If any measurements are greater than specified, replace the piston rings.

N.B.

BEFORE REPLACING ONLY THE PISTON RINGS, ENSURE THAT THE CLEARANCE BETWEEN THE PISTON RINGS AND THE PISTON RING GROOVES, AND BETWEEN THE PISTON AND THE CYLINDER, IS AS SPECIFIED. IN ANY CASE, NEW PISTON RINGS USED IN COMBINATION WITH A USED CYLINDER MAY HAVE DIFFERENT BEDDING CONDITIONS THAN THE STANDARD.

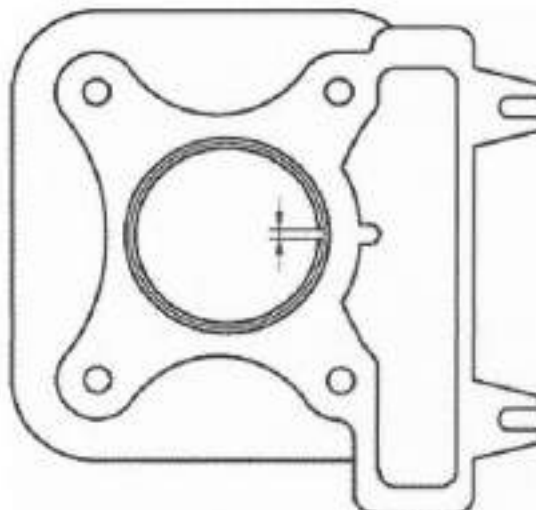

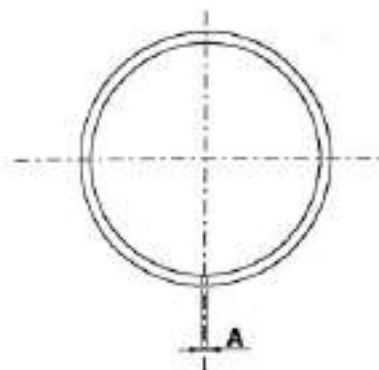

SEALING RINGS

Name	Description	Dimensions	Initials	Quantity
1st Compression ring		39 x 1	A	0.08 to 0.20
2nd Compression ring		39 x 1	A	0.05 to 0.20
Oil scraper ring		39 x 2	A	0.20 to 0.70
1st Compression ring 1st Oversize		39.2 x 1	A	0.08 to 0.20
2nd Compression ring 1st Oversize		39.2 x 1	A	0.05 to 0.20
Oil scraper ring 1st Oversize		39.2 x 2	A	0.20 to 0.70
1st Compression ring 2nd Oversize		39.4 x 1	A	0.08 to 0.20
2nd Compression ring 2nd Oversize		39.4 x 1	A	0.05 to 0.20
Oil scraper ring 2nd Oversize		39.4 x 2	A	0.20 to 0.70
1st Compression ring 3rd Oversize		39.6 x 1	A	0.08 to 0.20
2nd Compression ring 3rd Oversize		39.6 x 1	A	0.05 to 0.20
Oil scraper ring 3rd Oversize		39.6 x 2	A	0.20 to 0.70

Removing the piston

- Install piston and wrist pin onto the connecting rod, aligning the piston arrow the arrow facing towards the exhaust.
- Fit the pin retainer ring onto the appropriate tool.

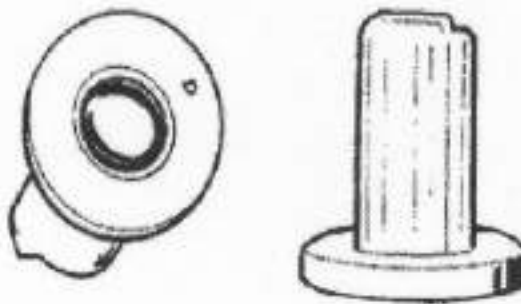

Specific tooling

020448Y Pin lock fitting tool

- With the opening in the position indicated on the tool, set the lock ring into position in the tool with the punch.
- Rest the tool on the piston paying attention that the 90° chamfered side faces upwards as indicated in the figure.
- Fit the gudgeon pin stop using the plug.

**CAUTION**

USING A HAMMER TO POSITION THE RINGS CAN DAMAGE THE LOCKING HOUSING.

Refitting the piston rings

- Fit the oil scraper ring starting from the spring, taking care that the spring ends do not superimpose. Fit the two piston rings so that their gaps and that of the oil scraper ring are never aligned.
- Fit the 2nd sealing ring with the identifying letter «T» facing towards the piston crown.
- Fit the 1st sealing ring with the reference letter «T» facing towards the piston crown.
- Misalign the lining openings at 120° as shown in the figure.
- Lubricate the components with engine oil.

**N.B.**

IN ORDER TO OBTAIN A GOOD BEDDING, THE 2 SEALING PISTON RINGS ARE MADE OF CONE SHAPED CONTACT SECTION TO THE CYLINDER. AS A RESULT IT IS IMPORTANT TO RESPECT THE FITTING INSTRUCTION TO ASSEMBLY THE RINGS WITH THE "T" MARK FACING UPWARDS.

Refitting the cylinder

- Insert the cylinder base gasket.
- Fit the cylinder as shown in the figure.
- The piston can be kept out of the housing plane using the appropriate tool.

N.B.

BEFORE FITTING THE CYLINDER, CAREFULLY BLOW OUT THE LUBRICATION DUCT AND OIL THE CYLINDER BARREL.

Specific tooling

020288Y Fork to assemble piston on cylinder



If the four cylinder stud bolts should be replaced in this kind of engine, it is necessary to tighten the head nuts strictly following the procedure below.

The procedure is different from that indicated in the vehicle manuals:

Head tightening nut (only to replace stud bolts) $6\div 7 \text{ N}\cdot\text{m} + 135^\circ + 90^\circ$

The 45° rotation reduction of the key is necessary to avoid stud bolt stretching.

Inspecting the cylinder head

- Using a trued bar check that the cylinder head surface is not worn or distorted.
- Check that the camshaft and rocking lever pin bearings show no signs of wear.
- Check that the cylinder head cover surface, the intake manifold and the exhaust manifold are not worn.
- It is advisable to replace the head if any failure is found.

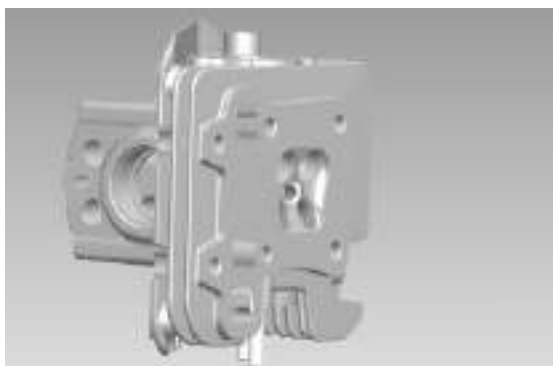
**Characteristic**

Maximum allowable run-out:

0.1 mm

Measure the camshaft bearing seats and rocking lever support pins with a bore meter

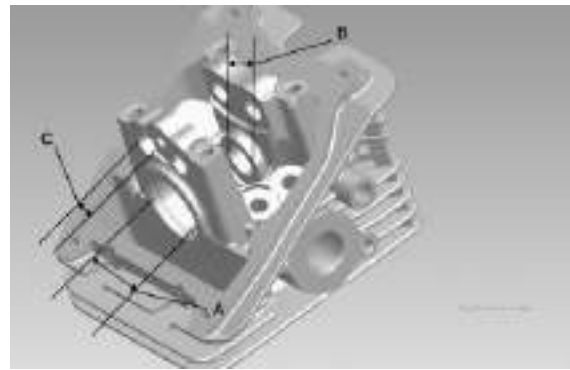

HEAD CHECK

Specification	Desc./Quantity
Standard diameter (mm) A	Ø 32.015 to 32.025 mm
Standard diameter (mm) B	Ø 16.0 to 16.018
Standard diameter (mm) C	Ø 11.0 to 11.018

Inspecting the timing system components

- Check that the guide slider and the tensioner slider are not worn out.
- Ensure that the camshaft drive pulley, the chain assembly and the sprocket wheel are not worn.
- If signs of wear are found, replace the parts. If the chain, pinion or pulley are worn, replace the whole assembly.

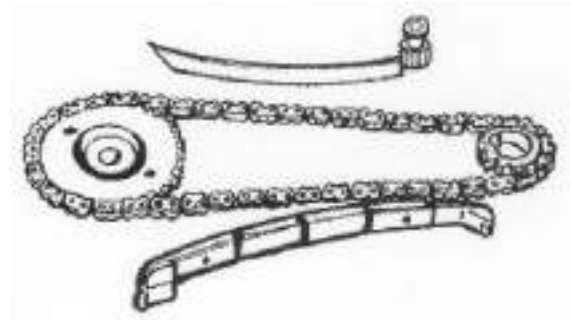

- Remove the central screw and the tensioner spring. Check that the one-way mechanism is not worn.
- Check the condition of the tensioner spring.
- If examples of wear are found, replace the whole unit.



Inspecting the valve sealings

- Clean the valve seats of any carbon residues.
- Using the Prussian blue, check the width of the impression on the valve seat "V".

Characteristic

Standard value:

1 - 1.3 mm

Admissible limit:

1.6 mm

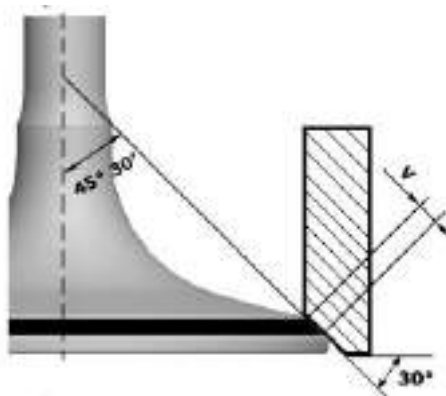

- If the impression width on the valve seat is larger than the prescribed limits, true the seats with a 45° mill and then grind.
- In case of excessive wear or damage, replace the head.

- Insert the valves into the cylinder head.
- Alternatively check the intake and exhaust valves.
- The test is carried out by filling the manifold with petrol and checking that the head does not ooze through the valves when these are just pressed with the fingers.



Inspecting the valves

STANDARD VALVE LENGTH

Specification	Desc./Quantity
Inlet: standard length	74.9 mm
Outlet: standard length	74.35 mm



- Measure the diameter of the valve stems in the three positions indicated in the diagram.

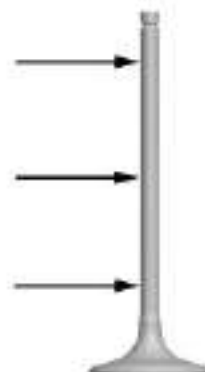

STANDARD DIAMETER

Specification	Desc./Quantity
Inlet	3.970 ÷ 3.985 mm
drainage	3.960 ÷ 3.975 mm

MINIMUM DIAMETER PERMITTED

Specification	Desc./Quantity
Inlet	3.958 mm
drainage	3.945 mm

- Calculate the clearance between valve and valve guide.

- Check the concentricity of the valve head by arranging a dial gauge at right angle relative to the valve head and rotate it on a "V" shaped abutment.

Characteristic

Admissible limit:

0.03 mm

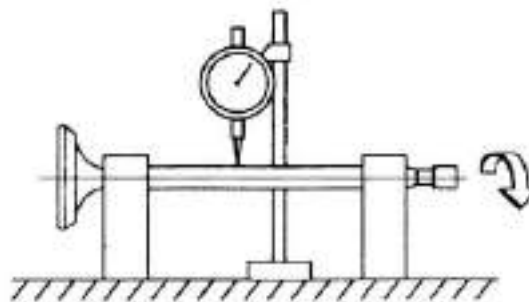

- Check the deviation of the valve stem by resting it on a «V» shaped abutment and measuring the extent of the deformation with a dial gauge.

Characteristic

Limit values admitted:

0.1 mm

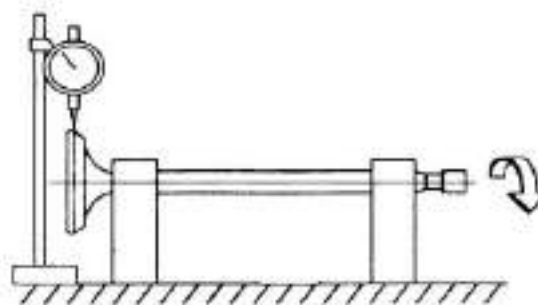

Inspecting the valve stem guide clearance

Measure the valve guides

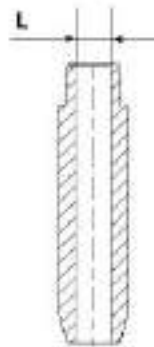

VALVE GUIDE DIAMETER

Specification	Desc./Quantity
Valve guide	Standard diameter: $4 + 0.012$ mm
Valve guide	Maximum admissible diameter: $4 + 0.022$ mm

- After measuring the valve guide diameter and the valve stem diameter, check clearance between guide and stem.



INTAKE

Specification	Desc./Quantity
Standard clearance	0.015 to 0.042 mm
Admissible limit	0.06 mm

EXHAUST

Specification	Desc./Quantity
Standard clearance	0.025 to 0.052 mm
Admissible limit	0.07 mm

Refitting the valves

- Lubricate the valve guides with graphite grease.
- Place the lower caps of the valve spring on the head.
- Use the punch to fit the 4 sealing rings one at a time.



- Fit the valves, the springs and the upper caps.
- Using the appropriate tool, compress the springs and insert the cotters in their seats.



Inspecting the cam shaft

- Inspect the camshaft for signs of abnormal wear on the cams.

Characteristic

Standard diameter - Bearing A:

$\text{Ø } 12 +0.002 +0.010$

mm Standard diameter - Bearing B:

$\text{Ø } 16-0.015 -0.023 \text{ mm}$

Minimum diameter allowed - Bearing A:

$\text{Ø } 11.98 \text{ mm}$

Minimum diameter allowed - Bearing B:

$\text{Ø } 15.96 \text{ mm}$

- Using a gauge, measure the cam height.

Check the axial clearance of the camshaft

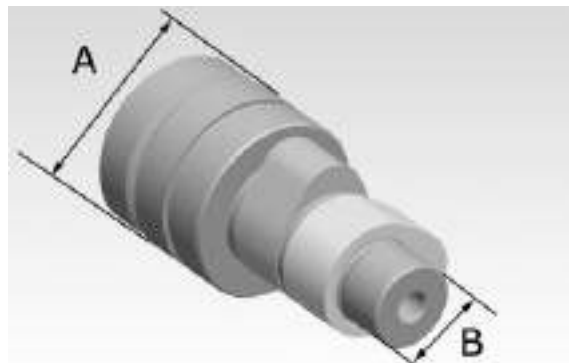

- If any of the above dimensions are outside the specified limits, or there are signs of excessive wear, replace the defective components with new ones.

N.B.

A BALL BEARING IS FITTED ON BEARING «A»; CONSEQUENTLY, BEARING «B» IS THE MOST IMPORTANT AS IT WORKS DIRECTLY ON THE HEAD ALUMINIUM

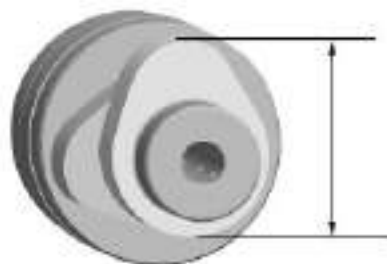

Characteristic

Standard height - Inlet

24.397 mm

Standard height - Outlet

23.996 mm

Fitting clearance

Maximum admissible axial clearance: 0.5 mm

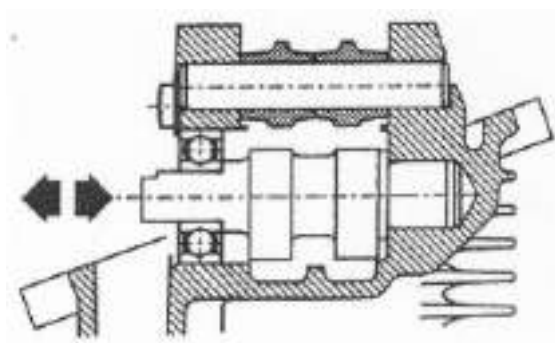

- Measure the outside diameter of the rocking lever pins
- Check the rocking lever pins do not show signs of wear or scoring.
- Measure the internal diameter of each rocking lever.
- Check that the pad in contact with the cam is not worn.

ROCKING LEVERS AND PIN DIAMETER:

Specification	Desc./Quantity
Rocking levers - Inside diameter	11.015 ÷ 11.035 mm
Rocking levers - Pins diameter	10.977 ÷ 10.985 mm



Refitting the head and timing system components

- Fix the head on a workbench.
- Screw the tool to fit the camshaft fully down on the bearing's inner track.
- Fit the camshaft fully into its seating together with the bearing with the aid of a mallet.
- Remove the tool.
- Fit the head gasket after cleaning the faying surface carefully.

- Insert the head in the cylinder stud bolts and tighten the 4 fixing nuts to the prescribed torque.

Specific tooling

020450Y Camshaft fitting/removal tool

- Fit pins, inlet rocking lever and discharge rocking lever.
- Lubricate the 2 rocking levers through the holes.

N.B.

IF A BEARING SEPARATES FROM THE CAMSHAFT, IT IS ESSENTIAL TO FIT A NEW BEARING.



- Screw up the limit screw of the rocking lever pins and tighten it to the prescribed torque.
- Reposition the Seeger ring retaining the camshaft

Locking torques (N*m)

Rocking lever shafts screw 3 ÷ 4

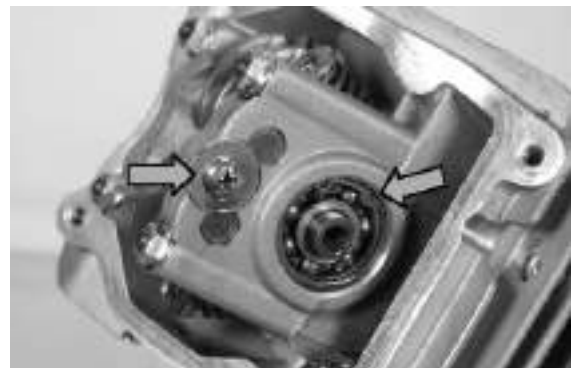

- Finish the head tightening following the procedure below: screw the four head nuts to an initial torque at two crossed passes. Afterwards tighten the nuts with 2 turns of 90° each to be done at two crossed passes.
- Finish the tightening of the head to the crankcase with the 2 side screws.

N.B.

SHOULD THE CRANKCASE OR THE CYLINDER STUD BOLTS BE REPLACED, IT IS NECESSARY TO CARRY OUT AN INITIAL TIGHTENING PLUS OTHER 3 TURNS OF 90° EACH AT 3 CROSSED PASSES

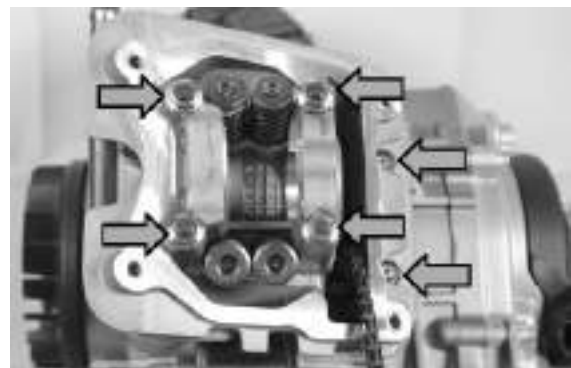

Locking torques (N*m)

Head-cylinder stud bolt nuts: 6 to 7 +135° +90° Nm first fitting, upon refitting tighten again at 6 to 7 90° +90° Nm Head cover screws 8 to 10 Nm

Refitting the timing chain

- Insert the timing chain pads in their corresponding seatings, the screw and the spacer as indicated in the figure.
- Tighten to the prescribed torque and check the tensioner pad moves adequately.
- Insert the timing pinion in driving shaft with the chamfered side facing the insertion (towards the main bearing).
- Loop the timing chain around the sprocket on the crankshaft.

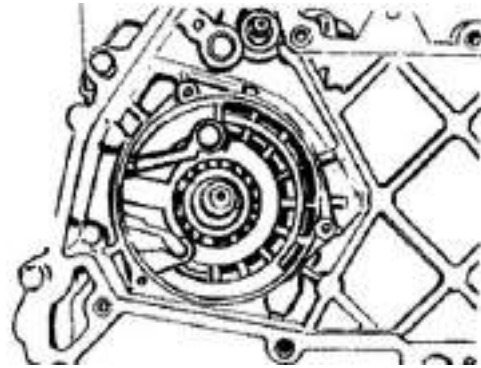

Locking torques (N*m)

Chain tensioner pad screw 5 to 7 Nm

- Refit the spacer on the cam shaft.
- Rotate the engine so that the piston is at top dead centre, using the reference marks on the flywheel and the crankcase.
- With this operation, insert the chain on the camshaft control pulley and make the reference notch coincide with the point on the head.
- Fit the pulley onto the camshaft.
- Fit the belleville washer so that the outer rim touches the pulley.
- Bring the screw closer but without reaching its final locking point.

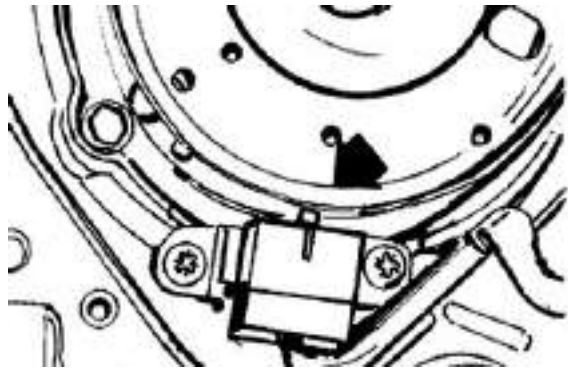

- Push the tensioner pad lightly so as to check the correct timing.
- Use the specific tool to lock the camshaft crown gear and tighten the screw.
- Adjust valve clearance.
- Replace the O-ring on the tappet cover.
- Fit the tappet cover and lock it with the 4 fixing screws indicated in the figure.



Specific tooling

020565Y Flywheel lock calliper spanner

Locking torques (N*m)

Camshaft pulley screw 12 to 14 Head cover screw 8 to 10 Nm

- Set the tensioner cursor in the rest position.
- Fit the chain tensioner on the cylinder, using a new gasket, and tight the two screws to the prescribed torque.
- Insert the spring with the central screw and tighten it to the prescribed torque.
- Fit the spark plug.

Electric characteristic

Distanza elettrodi:

0,6 mm

Spark plug

NGK ER9EH-6N

Locking torques (N*m)

Timing chain tensioner screw 8 to 10 Nm Timing chain tensioner central screw 5 to 6 Ignition spark plug 10 to 15 Nm

Refitting the rocker-arms cover

- Carry out the removal procedure but in reverse order and tighten the four fixing screws to the specified torque.

N.B.

FIT A NEW O-RING ON THE TAPPET COVER.



Refitting the intake manifold

- Fit the cover sealing gaskets on the head.
- Fit the 2 covers.
- Fit the inlet manifold and do up the 2 screws to the specified torque.
- Fit the carburettor on the inlet manifold and lock the clamp.
- Fit the secondary air pipe and fix it with the appropriate clamp.

N.B.

FIT THE CARBURETTOR THROUGH THE SUPPLEMENT ON THE MANIFOLD.



Locking torques (N*m)**Inlet manifold screw 7 to 9 Nm****Crankcase - crankshaft**

- First remove the following units:

Driving pulley Driven pulley

Final reduction greasing

Oil pump Flywheel with stator

Cylinder-piston-head unit

Starter motor with cables.

See also

[Removing the driving pulley](#)

[Removal](#)

[Removing the driven pulley](#)

[Removing the cylinder - piston assy.](#)

[Removing the starter motor](#)

[Removing the stator](#)

Splitting the crankcase halves

- Remove the ten crankshaft coupling screws.

-Separate the crankcase halves keeping the half casing driving shaft engaged on the transmission side.

- Remove the crankshaft.

CAUTION

IF YOU FAIL TO DO THIS, THE CRANKSHAFT MIGHT ACCIDENTALLY FALL.



- Remove the oil guard on the flywheel side.

CAUTION

THE CENTRIFUGAL OIL FILTER IS IN THE FLYWHEEL AXLE SHAFT. CONSEQUENTLY, DO NOT WASH WITH SOLVENTS OR BLOW COMPRESSED AIR SO THAT NO IMPURITIES LEAK OUT. A CENTRIFUGAL OIL FILTER'S LIFE IS THE SAME AS THE ENGINE'S AND IS MAINTENANCE FREE.

- Check the axial clearance on the connecting rod.

Fitting clearance

Standard connecting rod axial clearance 0.15 to 0.30 mm Max. connecting rod clearance 0.5 mm

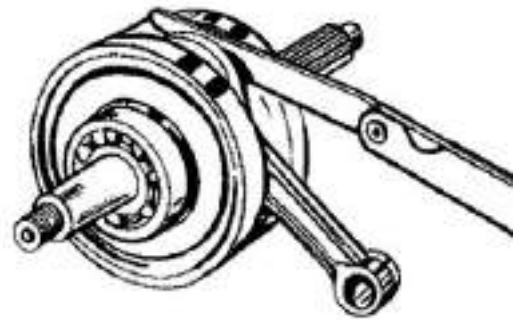

- Check the correct radial clearance of the connecting rod by holding the driving shaft with your hands and, with a dial gauge fitted to the rod small end, measuring the clearance, move the connecting rod vertically as shown in the figure.

Fitting clearance

Connecting rod radial - standard clearance 0.006 to 0.018 mm Connecting rod max. - radial clearance 0.25 mm

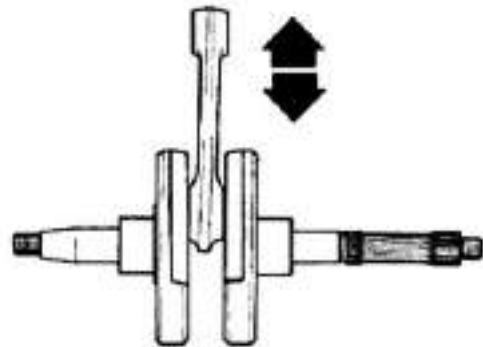

- Check that the half shaft surfaces are not scored and with the aid of a gauge check the driving shaft width as indicated in the figure.

Characteristic

Standard measure

45 mm

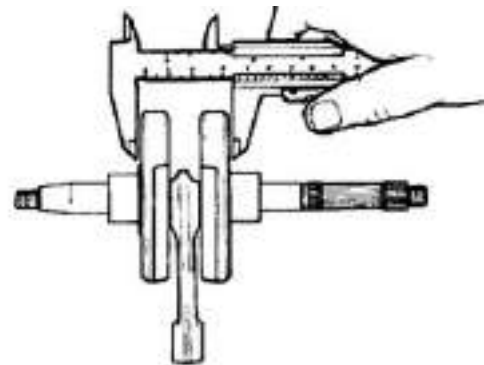

Removing the crankshaft bearings

- Remove the flywheel bearing fitted on the driving shaft using the specific tool.

Specific tooling

004499Y Camshaft bearing extractor

004499Y001 Bearing extractor bell

004499Y002 Bearing extractor screw

004499Y006 Bearing extractor ring

004499Y034 Bearing extractor part

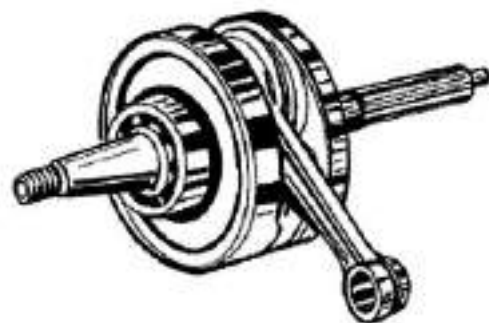

Refitting the crankshaft bearings

- Support the crankcase on a surface and place it with the driving shaft axle in a vertical position.
- Warm the crankcase at ~ 120° C with a thermal gun (and support).
- Fit the punch with guide and adaptor, place the bearing on the punch using grease (to keep it from falling).
- Insert the bearing in the crankcase; if needed, use a mallet but do so with extreme care so as not to damage the engine crankcase limit stop.

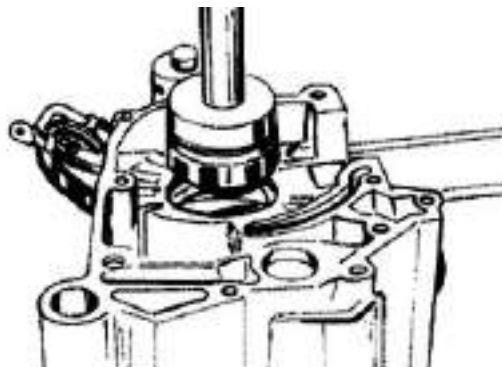

Specific tooling

020359Y 42x47-mm Adaptor

020364Y 25-mm guide

020376Y Adaptor handle

020360Y 52x55-mm Adaptor

-
- Heat a new main bearing in an oil bath at 120°.
 - Place the driving shaft on the support base and insert the bearing with the aid of an adequate piece of tube if necessary.

N.B.

USE A NEW BEARING WHEN REFITTING

WARNING

THE CENTRIFUGAL OIL FILTER IS IN THE FLYWHEEL AXLE SHAFT. DO NOT WASH WITH SOLVENTS OR BLOW COMPRESSED AIR SO THAT NO IMPURITIES LEAK OUT.

Specific tooling

020265Y Bearing fitting base

008119Y009 Tube to assemble shafts and axles



Inspecting the crankshaft alignment

- Install the crankshaft on the support and measure the displacement at the 4 points shown in the figure.

N.B.

IF VALUES OTHER THAN THOSE ALLOWED ARE DETECTED, TRY STRAIGHTENING THE CRANKSHAFT BY INSERTING A WOODEN WEDGE BETWEEN THE HALF SHAFTS OR BY CLOSING THEM WITH A VICE AS NEEDED. IF EVEN AFTER THIS OPERATION THE VALUES ARE NOT THOSE ADMITTED, REPLACE THE CRANKSHAFT.

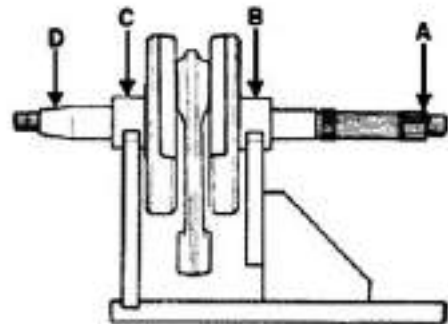

Characteristic

Off-line maximum admitted - A

0.15 mm

Off-line maximum admitted - B

0.02 mm

Off-line maximum admitted - C

0.02 mm

Off-line maximum admitted - D

0.10 mm

- Check that the driving shaft cone, the tab seat, the oil seal capacity, the toothed gear and the threaded tangs are in good working order.

- In case of failures, replace the crankshaft.

Specific tooling

020074Y Support base for checking crankshaft alignment

Refitting the crankcase halves

-Be careful to place the two centring dowels preferably on the flywheel side half casing.

-Insert the crankshaft on the half casing on the transmission side.

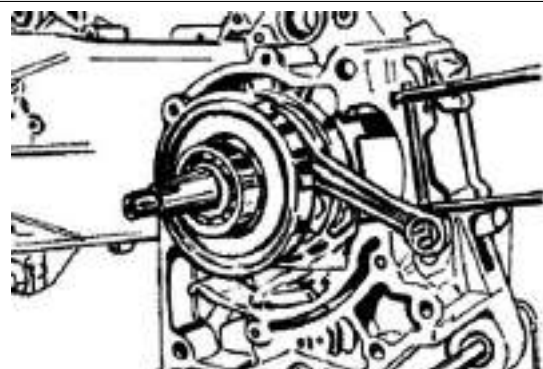

- Fit the gasket recommended for surfaces on the half casing on the transmission side after greasing the two faying surfaces carefully.
- Insert the flywheel half casing.
- Fit the 10 screws and tighten them to the prescribed torque.

**N.B.**

WHEN FITTING THE HALF CASING AND THE CRANK-SHAFT, TAKE CARE NOT TO DAMAGE THE SHAFT THREADED TANGS.

Recommended products

Loctite 510 Liquid sealant

Gasket

Locking torques (N*m)

Half casing joint bolts: 8 to 10 Nm

- Fit a new O-Ring on the mesh oil filter and on the filling cap; lubricate the rings.
- Insert the filter on the engine and lock the cap to the prescribed torque.

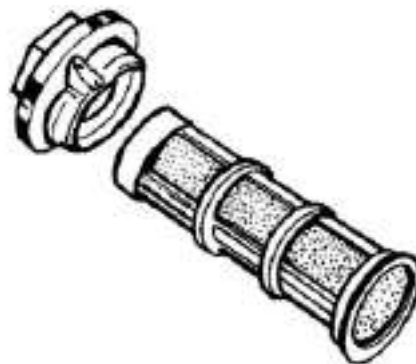
**Locking torques (N*m)**

Engine oil pre-filter cover: 25 to 28 Nm

Lubrication**Crankshaft oil seals****Removal**

- Extract the flywheel oil seal from the crankcase being careful not to damage or score the crankcase.

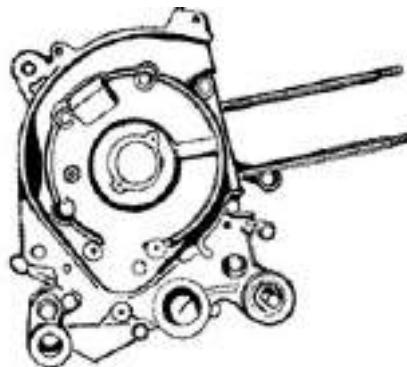

- Check that the chain contrast pad is not worn.
- Otherwise, replace the pad or fit it inverted to make it work on the other side.
- Any operation on the chain cover oil seal should be carried out placing the cover on the workbench on the covering plate side of the oil pump chain.
- Remove the oil seal with a tube section of 30 mm in diameter (\varnothing 32 mm Max).



Refitting

- Apply engine oil on the oil seal and its seating on the crankcase.
- From the outside and using the specific punch, place the oil seal fully down until it reaches the bottom of the seating in the crankcase.

N.B.

FAILURE TO USE THE SPECIFIC TOOL CAN RESULT IN AN INCORRECT DEPTH POSITION AND AS A CONSEQUENCE IN INADEQUATE OIL SEAL.

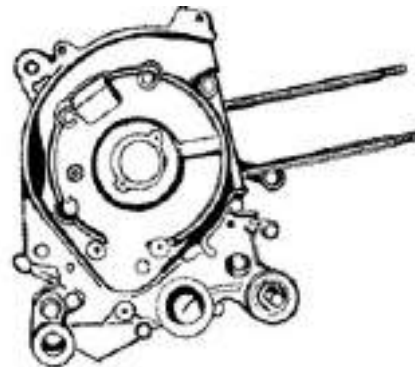

- Fit a new oil seal on the outer rim with the help of the specific tools below.
- Fit a new O-ring and lubricate it with grease.
- Install the cover on the engine crankcase, insert the three screws and place the cover in its position.
- Tighten the 3 screws to the prescribed torque.

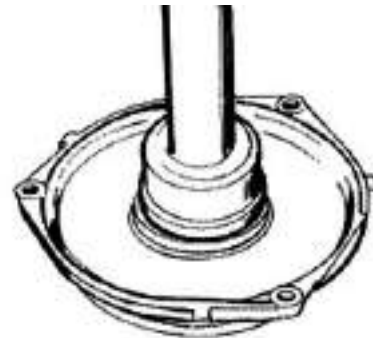

Specific tooling

020376Y Adaptor handle

020358Y 37x40-mm Adaptor

Locking torques (N*m)

Timing chain/oil pump compartment cover screws 4 to 5 Nm

Oil pump

Removal

- Remove the chain compartment cover undoing the 3 fixing screws indicated in the figure.
- Take out the cover using the appropriate fusion couplings on the cover with a pair of pliers

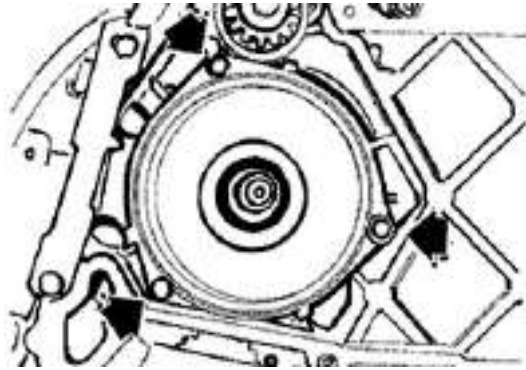

- Undo the 2 clamping screws in the figure and remove the cover over the pump control crown gear.
- Block the rotation of the oil pump control gear with a screwdriver inserted through one of its pump holes.

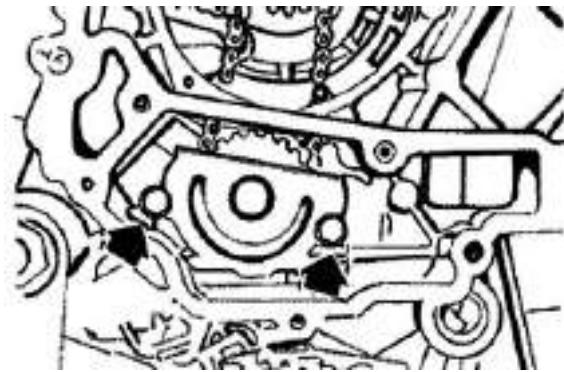

- Remove the central screw and the Belleville washer
- Remove the chain with the crown gear.
- Remove the crankshaft control pinion.
- Remove the oil pump by undoing the 2 screws indicated in the figure.
- Remove the oil pump seal.

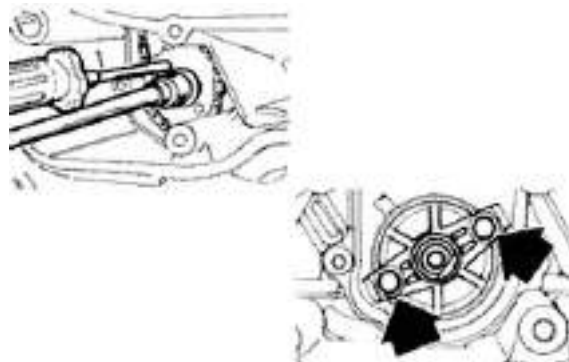

IT IS ADVISABLE TO MARK THE CHAIN IN ORDER TO ENSURE THAT THE INITIAL DIRECTION OF ROTATION IS MAINTAINED.

Inspection

- Remove the two screws and the oil pump cover.
- Remove the clip retaining the innermost rotor.
- Remove and wash the rotors thoroughly with a degreasing solvent and compressed air.
- Reassemble the rotors in the pump body, keeping the two reference marks visible. Replace the clip.



- Measure distance between rotors (inner rotor/ outer rotor) with a thickness gauge in the position shown in the picture.

Characteristic**Admissible maximum clearance 1**

0.15 mm

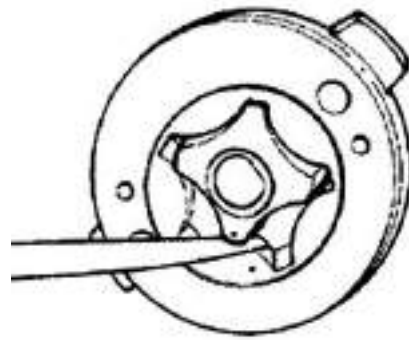

- Measure the distance between the outer rotor and the pump body (see figure).

Characteristic**Admissible maximum clearance 2**

0.20 mm

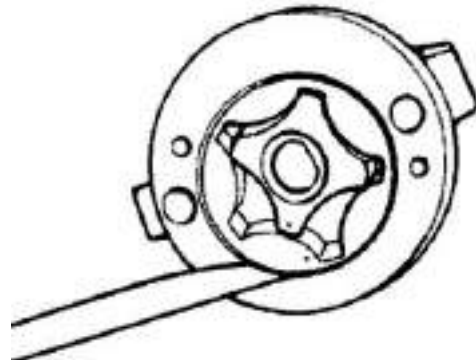

- Check the axial clearance of the rotors using a trued bar as reference as shown in the figure.

N.B.

MAKE SURE THE TRUED BAR IS POSITIONED PROPERLY ON THE TWO POINTS ON THE PUMP BODY.

Characteristic**Admissible maximum clearance 3**

0.09 mm

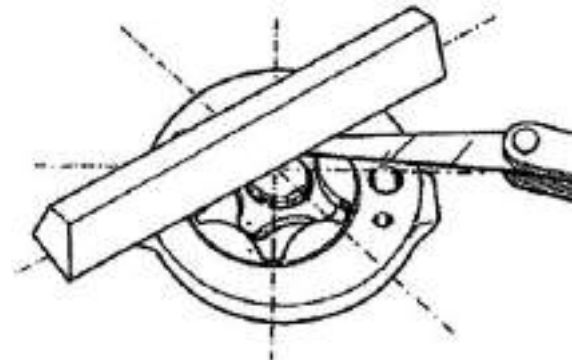
**Refitting**

- Check there are no signs of wear on the oil pump shaft or body.
- Check there are no signs of scoring or wear on the oil pump cover.
- If you detect non-conforming measurements or scoring, replace the faulty parts or the assembly.
- Fit the cover on the pump being careful to align the holes (2 on the cover and 2 on the pump body) fixing the oil pump on the crankcase.
- Fit the oil pump on the crankcase by tightening the two screws to the prescribed torque.



- Fit the pulley on the pump, the central screw to the specified torque and the belleville washer.
- Check that there is no seizing and/or friction during the pulley rotation.

N.B.

FIT THE CUP WASHER SO THAT ITS OUTER (CURVED) RIM TOUCHES THE PULLEY.

Locking torques (N*m)

Central screw 12 to 14 Nm Cover screws 0.7 to 0.9 Nm Oil pump screws 5 to 6

Removing the oil sump

- Remove the oil filling cap, the transmission cover, the complete driving pulley assembly with belt and pinion.
- Unscrew the oil drainage plug «A» shown in the figure and drain out all the oil from the sump.
- Remove the 6 screws indicated in the figure.

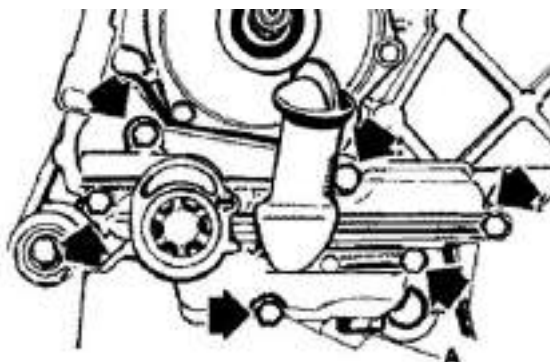
**Refitting the oil sump**

- Clean and grease the faying surfaces.
- Apply LOCTITE 510 on the sump surface and tighten the 6 fixing screws to the specified torque.
- Refit the driving pulley assembly, the belt, the pinion and the transmission cover.

WHEN TESTING THE LUBRICATION SYSTEM, REFER TO THE "CRANKCASE AND CRANKSHAFT" CHAPTER, REGARDING LUBRICATION OF THE CRANKSHAFT AND CONNECTING ROD

Locking torques (N*m)

Oil sump screws 8 to 10 Nm

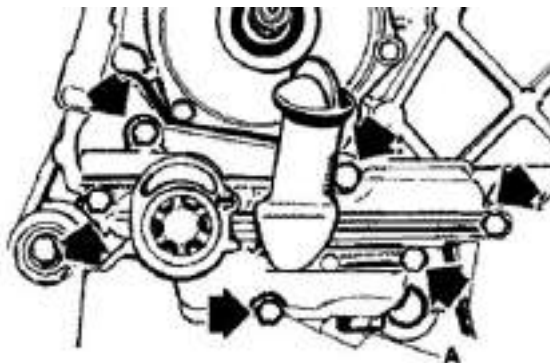

Fuel supply

- Disconnect the fuel supply and the suction taking pipe from the carburettor.
- Check that there are no fuel leaks between the two tubes.
- Close the fuel outlet pipe.
- By means of the MITYVAC pump apply 0.1 bar of suction to the tap.
- Make sure that the suction is kept stable and that and that there are no fuel leaks.
- Reconnect the vacuum pipe to the manifold.
- Position the fuel pipe with the outlet at the point of the tap.
- Turn the engine by using the starter motor for five seconds with the carburettor at minimum.
- Take up the fuel by means of a graded burette.

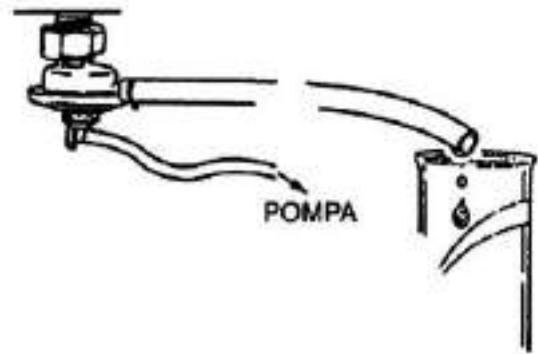

N.B.

THE MEASUREMENT MAY BE FALSIFIED BY THE INCORRECT NUMBER OF REVS OR BY THE WRONG POSITION OF THE TUBE. IN THIS CASE, THE TENDENCY IS TO OBTAIN A REDUCED FUEL FLOW RATE. THE SUCTION OUTLET ON THE MANIFOLD HAS A SECTION INTENTIONALLY REDUCED FOR THE PURPOSE OF ENHANCING THE SUCTION PULSATION AND THEREBY GUARANTEE A CONSTANT TAP FLOW RATE.

Specific tooling

020329Y Mity-Vac vacuum-operated pump

Characteristic

Minimum flow rate

20 cc

- Completely empty the fuel tank.
- Remove the petrol delivery pipe and the low-pressure pipe.
- Loosen the clip and remove the cock.
- Clean the tank and the filter of the cock with a specific solvent.
- Refit the cock making sure that there is an O-Ring.
- Turn the cock to the direction it had before it was removed and block the clip.

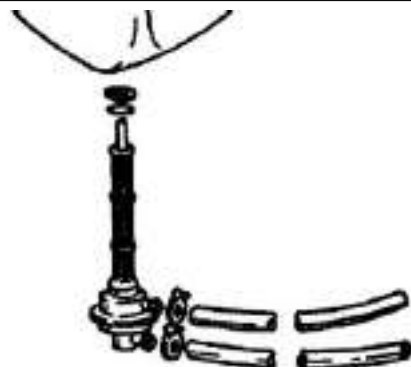

N.B.

THE FILTER CAN BE UNSCREWED FROM THE COCK TO FACILITATE CLEANING.

Removing the carburettor

- To detach the carburettor from the engine, remove the two clamps anchoring the carburettor to the inlet manifold and the air intake coupling to the filter.

- Remove the fuel supply pipe.
- Disconnect the starter connection.
- Detach the accelerator cable with the sheath that connects the plate and the support.
- Remove the carburettor.



- Remove the protection, the bracket and the starter undoing the screw shown in the figure.

CAUTION

THE CARBURETTOR FEATURES AN ANTI-VIBRATION RUBBER BUFFER FITTED ON THE LOWER SUPPLEMENT OF THE ACCELERATING PUMP BODY. UPON REFITTING THE CARBURETTOR ON THE ENGINE, MAKE SURE THIS BUFFER IS PRESENT SO THAT THE PETROL IN THE TANK DOES NOT EMULSIFY.

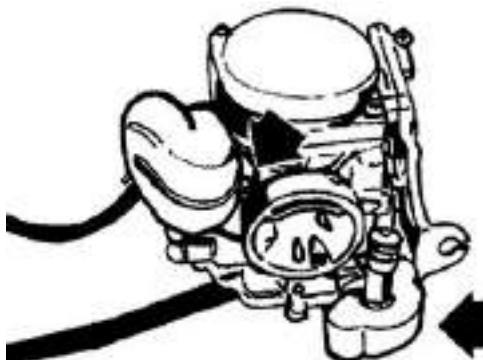

- Remove the 2 fixing screws indicated in the figure, the vacuum chamber cover and the spring.
- Remove the vacuum valve together with the diaphragm; the pin, the spring and its plastic guide.

WARNING

DURING THE REMOVAL OF THE COVER TAKE SPECIAL CARE NOT TO RELEASE THE SPRING ACCIDENTALLY.

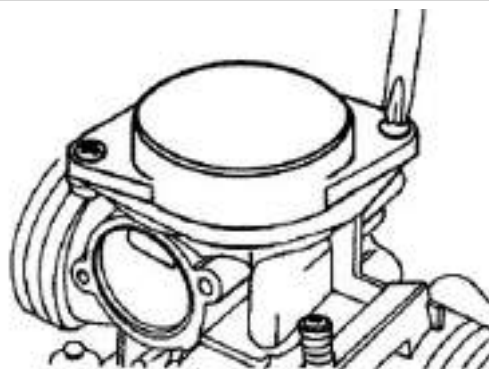

- Remove the 3 fixing screws and the chamber with the gasket.

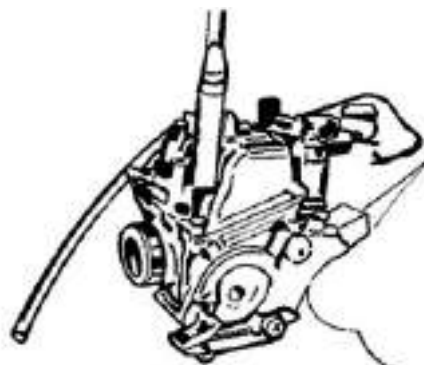

-
- Remove the chamber components following the procedure below.
 - Undo the 2 screws fixing the intake pump diaphragm cover.



-
- Remove the cover being careful with the spring below, then remove the spring, take out the rubber protection and the diaphragm together with the pipe O-Ring.



-
- Remove the accelerating pump jet together with the ball spring.

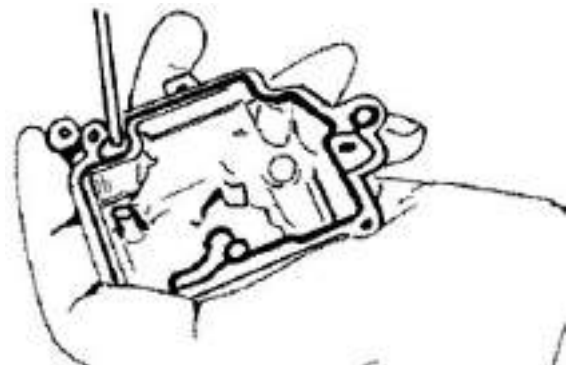

-
- Remove the screw indicated in the figure fixing the float pin.
 - Remove the float and the plunger.



- Remove the maximum nozzle.
- Remove diffuser.

-Remove the minimum nozzle.



- Remove the sprayer tilting the carburettor body.

N.B.

THIS OPERATION IS NECESSARY TO AVOID LOSING SPRAYER PARTS WHEN CLEANING THE CARBURETTOR BODY. IF THE SPRAYER IS FORCED IN ITS HOUSING DO NOT ATTEMPT TO REMOVE IT AS THIS WILL ONLY DAMAGE IT.

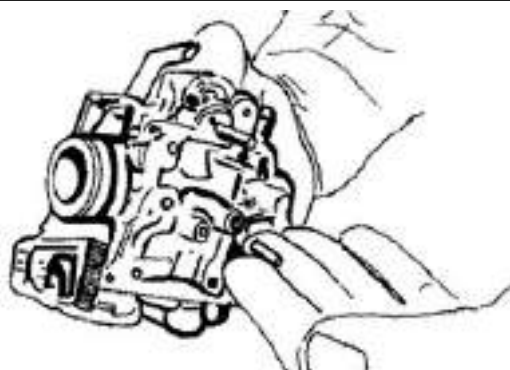

- Remove the idle flow screw with the O-ring and the spring.



CAUTION

DO NOT ATTEMPT REMOVING PARTS EMBEDDED IN THE CARBURETTOR BODY SUCH AS: FUEL SUPPLY PIPE, PIN SEATING, STARTER NOZZLE, THROTTLE VALVE CONTROL VALVE SHAFT. DO NOT REMOVE THROTTLE-SHAFT CONNECTION SCREWS. THE FIXING SCREWS ARE CAULKED AFTER THE ASSEMBLY AND THEIR REMOVAL DAMAGES THE SHAFT.

Refitting the carburettor

- Before refitting, wash the carburettor body accurately with a degreasing solvent and compressed air.
- Pay special attention to the fuel supply pipe and the plunger seat.

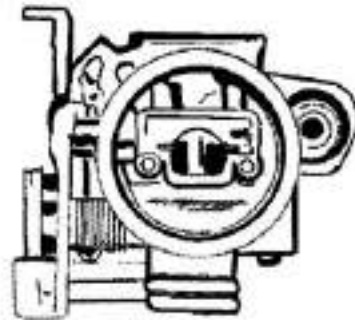

- For the minimum circuit, make sure the following points are properly cleaned: air gauging, exhaust section controlled by flow screw, progression holes near the throttle valve.

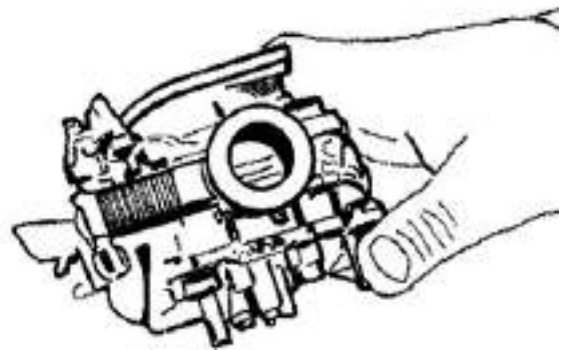

- For the starter circuit, blow the connection pipe properly with the jet. This is necessary because the nozzle support hides other inaccessible internal calibrations.

- Blow the intake nozzle properly.

The acceleration nozzle outlet is extremely small and is oriented to the throttle valve.

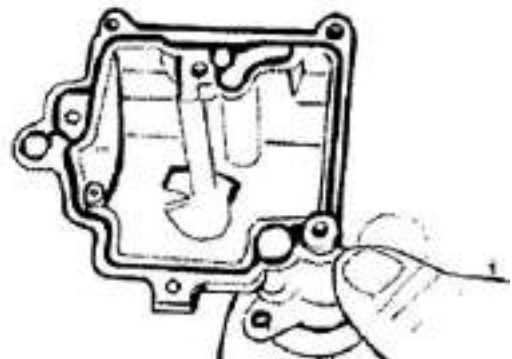

- Check that the carburettor body has the closing ball for the idle circuit pipe.
- Check that the coupling surfaces, the chamber and the diaphragm are not dented.
- Check that the depression valve housing pipe is not scratched.
- Check that the throttle valve and the shaft do not show abnormal wear.
- Check that the plunger seat does not show abnormal wear.
- Replace the carburettor in case of irregularities.

N.B.

TO AVOID DAMAGES, DO NOT INTRODUCE METAL OBJECTS IN THE ADJUSTED SECTIONS.

- Wash and blow the minimum nozzle properly and reassemble it.



- Accurately wash and blow the components of the maximum circuit, the sprayer, the diffuser and the nozzle.
- Introduce the sprayer in the carburettor body with the bigger cylindric part directed to the diffuser.
- Fit the diffuser.
- Assemble the maximum nozzle.



- Check that the tapered pin does not show signs of wear on the sealing surfaces of the shock absorber pin and the return clamp.
- Replace the rod if worn out.
- Check that the float is not worn on the pin housing or on the contact plate with the rod and that there are no fuel infiltrations.
- Replace it in case of failures.
- Fit the float together with the pin and rod in its position and lock it with its screw.

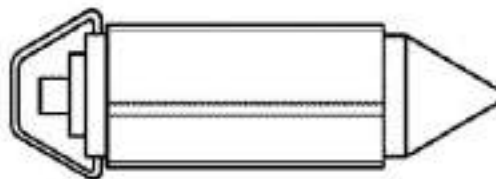

N.B.

INTRODUCE THE RETURN SPRING ON THE FLOAT PLATE ADEQUATELY

- Insert the ball in the corresponding accelerating pump.
- Fit the spring.
- Fit the accelerating pump nozzle.

WARNING

WHEN REFITTING, PAY SPECIAL ATTENTION TO THE COMPONENTS AS THEY ARE SMALL.

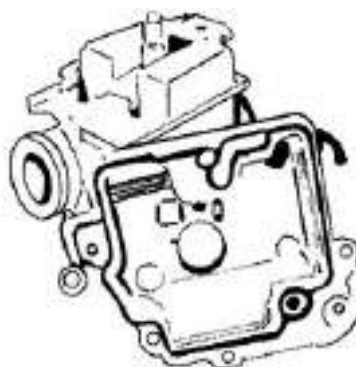

- Check the diaphragm is in good conditions and remove the remaining components of the accelerating pump following these steps:
- Insert the O-Ring in the pipe.
- Insert the diaphragm together with the pin and its spring.



N.B.

REPLACE THE DIAPHRAGM IF THERE ARE SIGNS OF UNDULATIONS, CRACKS OR HARDENING.

- Fit the accelerating pump diaphragm cover and tighten the 2 fixing screws making sure the spring below is correctly positioned.
- Fit the rubber bellows protecting the pin in the upper part of the accelerating pump.



Level check

- Tilt the carburettor so that the needle valve at the fuel supply is closed and the float weight does not affect it.
- Check that the diaphragm closing line and the float central line are parallel as shown in the figure.

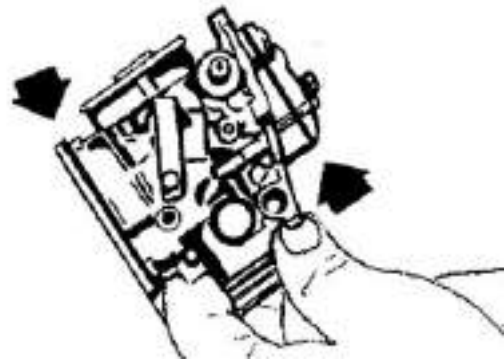

- Blow air in to the tank and then assembly it and its gasket on the carburettor body with the 3 fixing screws.

N.B.

-ALWAYS USE NEW RINGS AND GASKETS FOR REFITTING.

WARNING

THE SCREW IN THE TANK BOTTOM IS A BLEEDING ONE AND CONSEQUENTLY IT ONLY REQUIRES CLEANING.

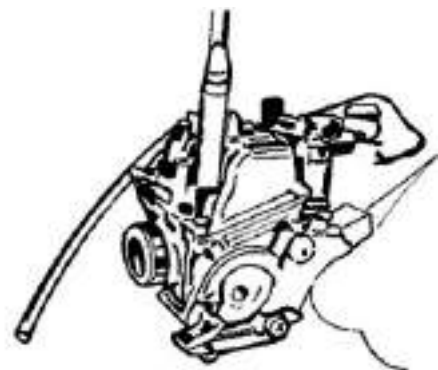

- Insert the diaphragm into the throttle valve.
- Insert the tapered pin together with the plastic support and the contrast spring into the throttle valve.

N.B.

PLACE THE SPRING PLASTIC SUPPORT WITH ITS TEETH FACING THE INNER SIDE OF THE MEMBRANE TO BE ABLE TO FIT THE LOWER END OF THE THROTTLE VALVE SPRING.

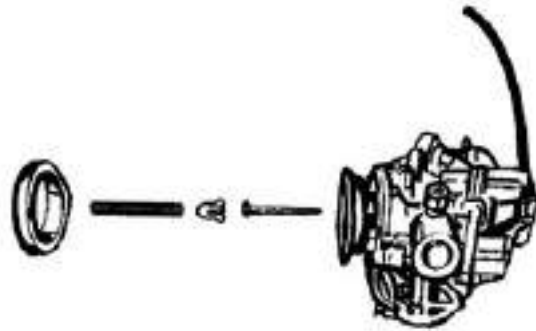

- Fit the vacuum chamber cover with the 2 fixing screws paying special attention to the spring.

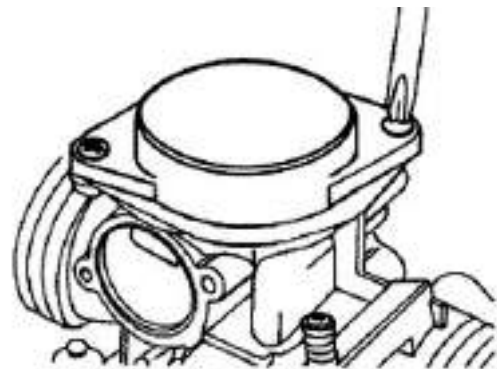

Inspecting the automatic choke device

- Check that the automatic starter piston is not deformed or rusty.
- Check that the piston slides freely in its seating.
- Check that the piston sealing O-Ring is not deformed.
- The starter must be more or less functional depending on the ambient temperature.
- Measure the protrusion of the piston as shown in the figure and check its corresponding value.
- Make sure that the starter is adjusted for the ambient temperature.

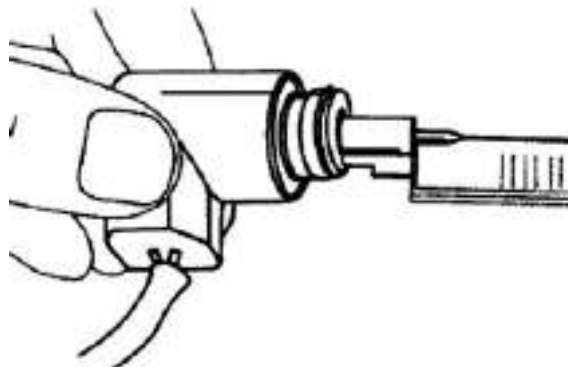
**Characteristic****Protrusion value**

11.5 mm

ambient temperature

24° C

- The starter should disconnect progressively by means of electric heating.
- Check the starter resistance when adjusted to the ambient temperature.



Characteristic ambient temperature

24° C

Electric characteristic Automatic starter resistance

20 Ω ± 5 %

- Use battery to power the automatic starter and check that piston protrudes as much as possible.
- The correct warm up time depends on the ambient temperature.
- If protrusion, resistance or timing values are different from the ones prescribed, replace the starter.

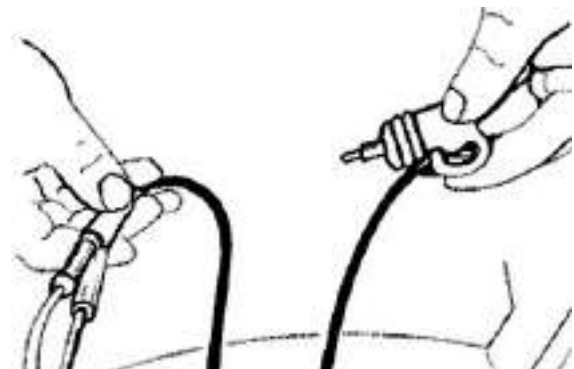

Characteristic Battery

12V-9Ah

max. protrusion

15 mm

max. time

15 min

- Fit the starter, the support bracket and the protection with the screw indicated in the figure.

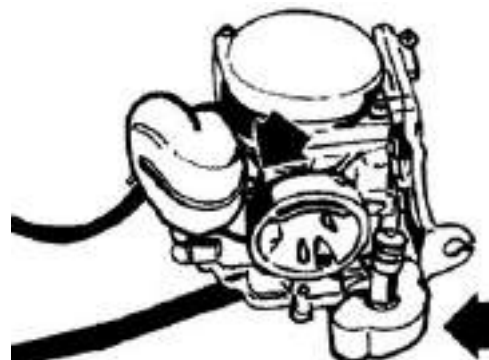

- Insert rubber pipes for chamber ventilation.
- Insert the O-Ring, the washer, the spring and the idle flow screw in their seatings.



- Refit the carburettor on the engine and connect again the accelerator cable with the sheath and the support plate and the electrical connection of the starter.
- Reconnect the fuel supply pipe and tighten the 2 clamping screw fixing the carburettor to the inlet manifold and the air inlet coupling to the filter.



Adjusting the idle

- The engine does not require frequent idle speed adjustments, but it is essential to strictly follow certain rules when adjusting the idle speed.
- Before adjusting the carburettor make sure to respect requirements on lubrication, valve clearance, and complying timing; spark plug should be in optimum conditions, air filter clean and sealed, and the exhaust system tight.

- Connect the tester thermometer to the sump, using a cover with oil expressly prepared for probes.
- Start the engine and before adjusting the idle speed, make sure that the oil temperature is between 70÷80 °C.

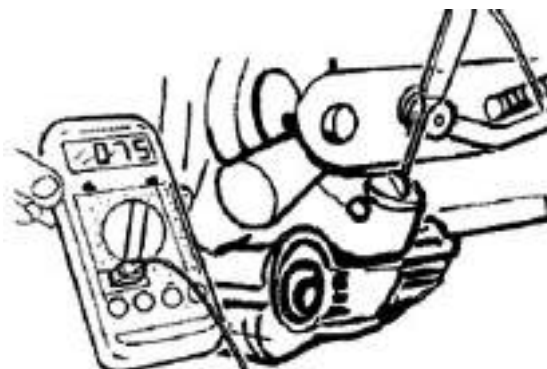

Specific tooling

020331Y Digital multimeter

- Using the rpm indicator in the analyser or a separate one, adjust the idle screw.

N.B.

THE WASTED SPARK IGNITION SYSTEM OFFERS REMARKABLE POWER. READINGS MAY NOT BE ACCURATE IF INADEQUATE RPM INDICATORS ARE USED.

Specific tooling

020332Y Digital rpm indicator

Characteristic

Idle speed

about 1900/2000 rpm

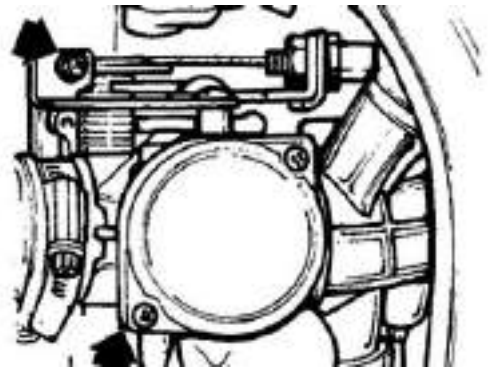

INDEX OF TOPICS

SSUSPENSIONS

SUSP

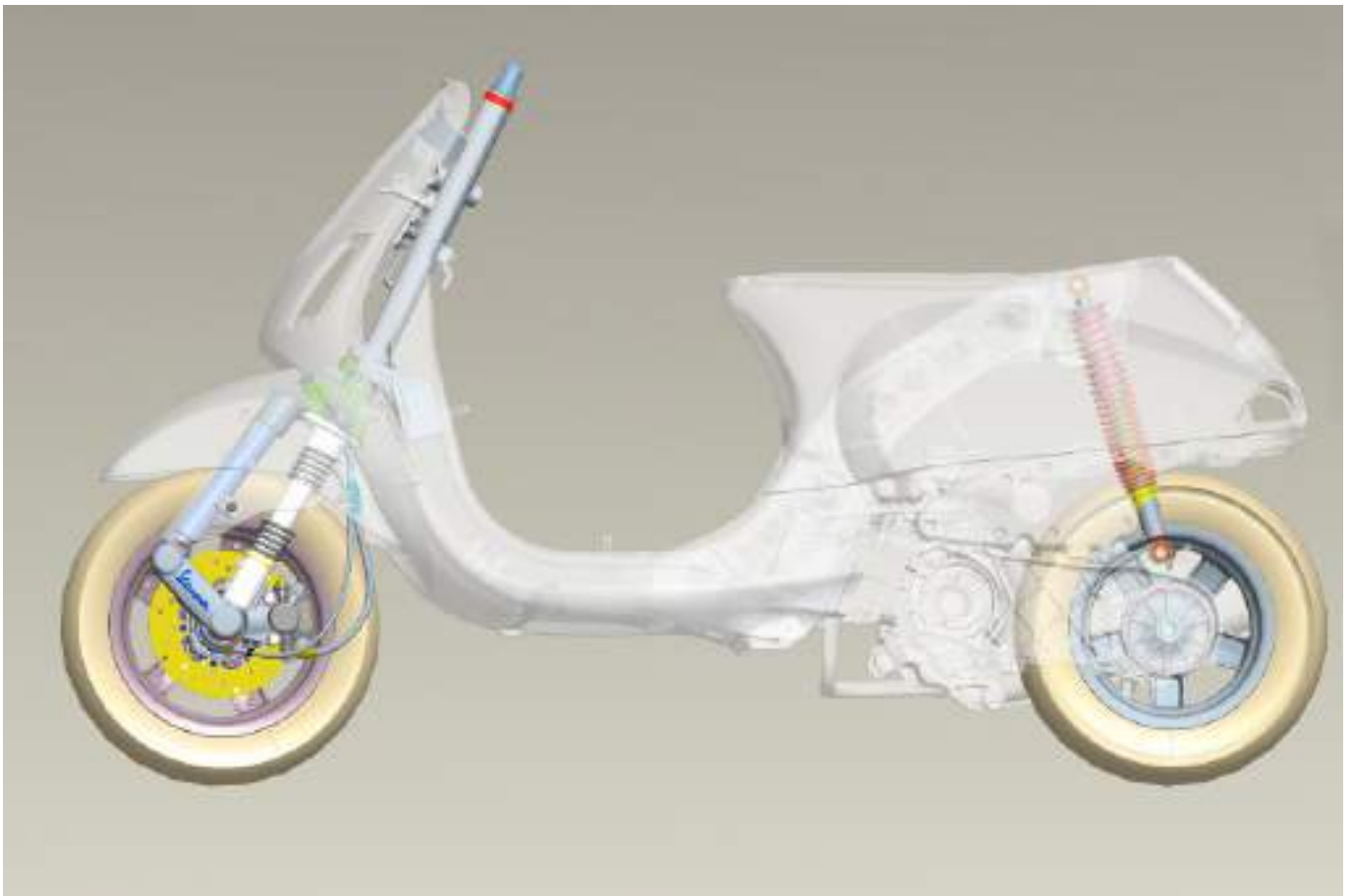

Front

Removing the front wheel

- Remove the five Allen screws that fix the wheel to the hub.

N.B.

BEFORE REMOVING THE WHEEL HUB, REMOVE THE BRAKE CALLIPER.

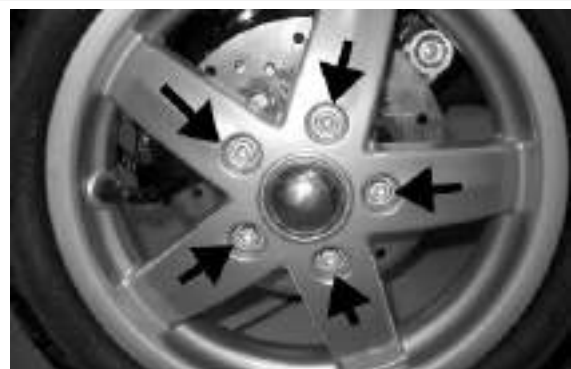

Front wheel hub overhaul

- Remove the ball bearing check Seeger ring indicated in the picture



Extract the ball bearing using the specific tool

Specific tooling

001467Y014 Calliper to extract \varnothing 15-mm bearings

001467Y017 Bell for bearings, OD 39 mm



- Remove the oil seal on the roller bearing side using a screwdriver.



- Remove the roller bearing using the specific tool

Specific tooling

020376Y Adaptor handle

020456Y \varnothing 24 mm adaptor

020363Y 20-mm guide



- Heat the roller bearing seat with a heat gun
- Use the specific tool to introduce and push the bearing until it stops, with the shielded side facing out
- Refit the ball bearing check Seeger ring

Specific tooling**020151Y Air heater****020376Y Adaptor handle****020359Y 42x47-mm Adaptor****020412Y 15-mm guide**

- Use the specific tool to fit and push the roller casing until it stops
- Refit the oil seal on the roller bearing side
- Lubricate the area between the roller bearing and the ball bearing

Specific tooling**020038Y Punch****Recommended products****AGIP GREASE MU3 Grease for odometer transmission gear case**

Soap-based lithium grease with NLGI 3; ISO-L-XBCHA3, DIN K3K-20

**Refitting the front wheel**

- When refitting, tighten the 5 screws to the specified torque

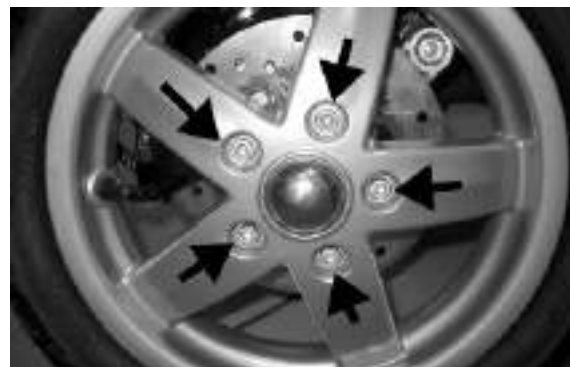
Locking torques (N*m)**Nut tightening torque 20 to 25 N•m****Handlebar**

Removal

Remove the handlebar cover before carrying out this operation,.

- After removing the transmissions and disconnecting the electrical terminals, remove the terminal fixing the handlebar to the steering.
- Check all components and replace faulty parts.

N.B.

IF THE HANDLEBAR IS BEING REMOVED TO REMOVE THE STEERING, TILT THE HANDLEBAR FORWARD TO AVOIDING DAMAGING THE TRANSMISSIONS.

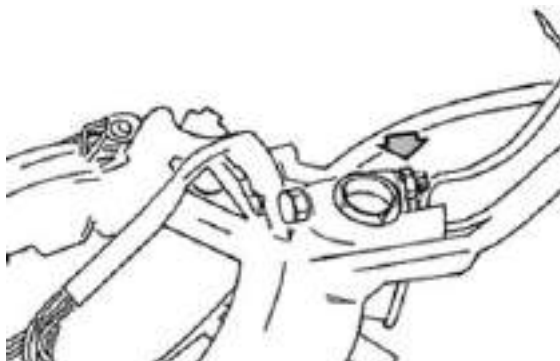

Refitting

Carry out the removal operations but in the reverse order, observing the prescribed tightening torque.

Locking torques (N*m)

Handlebar lock nut 45 to 50

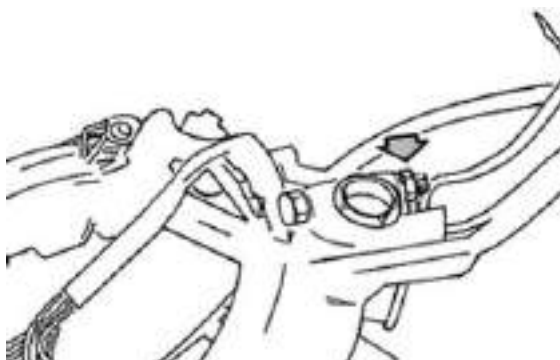

Steering column

Removal

After removing the upper seat, lean the vehicle on one side and extract the steering tube completely from the fork.

Specific tooling

020055Y Wrench for steering tube ring nut



Overhaul

-The front suspension service operation is useful to replace the connecting parts between the steering tube and the swinging hub of the front wheel holder, provided that the steering tube and the wheel holder hub are in excellent conditions.

- Press and remove the wedging washer with the help of a pointed end.
- For the second washer, repeat the operation using the punch on the side opposite to the one shown in the figure.

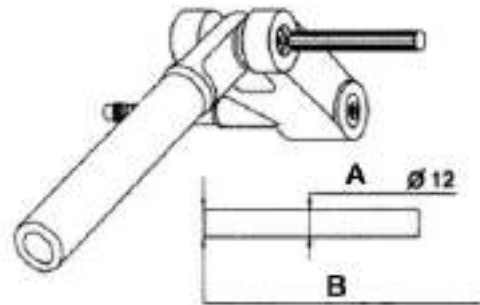

A = $\varnothing 12$ Punch

B = Sharp-edged end

- Use the specific tool, fitted with part 1*, and operate the handgrip until the pin and the Nadella are simultaneously ejected in the direction opposite the tool thrusting force.
- To eject the second Nadella, use the tool fitted with part 2* instead of part 1, on the side opposite the one shown in the figure.

* Supplied with the tool

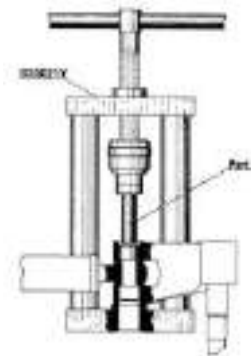

Specific tooling

020021Y Front suspension service tool

- Use the tool fitted with part 20* and part 21* on its stem as shown in the figure.
- Push the two roller casings with the handgrip until their bottoms make contact with the pin end.

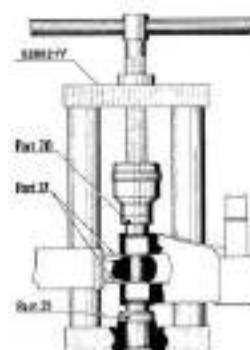

- Fit both dust guard rings «C» on the swinging hub as shown in the detail drawing «A».
- Connect the swinging hub to the steering tube with the guide pin, part 5*.
- Use the specific tool fitted with part 3* on its stem and with part 4 at the bottom of the tool.
- Insert the previously greased pin on the swinging hub and with the tool handgrip, move part 3 until it stops on the steering tube.
- After fitting the pin, insert the two spacers, part 17*, slightly hitting with the mallet.

* Supplied with the tool

Specific tooling

020021Y Front suspension service tool

Recommended products

AGIP GREASE PV2 Grease for control levers on the engine

White anhydrous-calcium based grease to protect roller bearings; temperature range between -20 °C and +120 °C; NLGI 2; ISO-L-XBCIB2

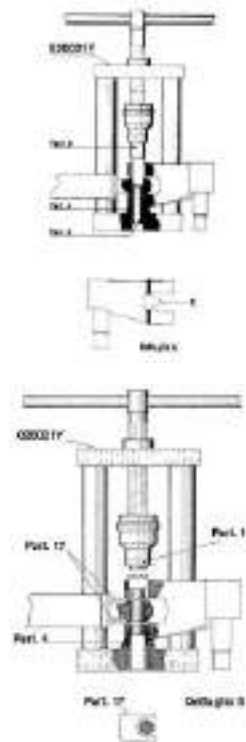

- Lubricate the sealing rings with mineral oil and half-fill the roller casings with grease.
- Insert the sealing ring on the pin and the roller bushing with wedging washers at the same time.
- Remove the specific tool, then the part 5 (guiding) partially ejected in the previous assembly stage; leave part 4* always fitted.
- Replace part 3 with part 16* on the stem.
- Push, from the handgrip, the wedging washer - roller casing - sealing ring unit, placing part 16 until it stops on the swinging hub
- Repeat the operation described above using the tool fitted with part 16 and part 22* instead of part 4 on the stem, on the side opposite the one shown in the figure to refit the second wedging washer - roller casing - sealing ring unit.

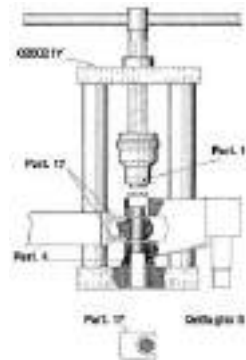

* Supplied with the tool

Specific tooling

020021Y Front suspension service tool

Recommended products

AGIP GREASE PV2 Grease for control levers on the engine

White anhydrous-calcium based grease to protect roller bearings; temperature range between -20 °C and +120 °C; NLGI 2; ISO-L-XBCIB2

Use the tool fitted with parts 3 and 4, as indicated to fit the pin, and press operating the handgrip, until wedging the washers on the swinging hub.

- Remove the spacers, part 17, fill with grease the area between the steering tube and the swinging hub, and place the dust guard rings in that place.

* Supplied with the tool

N.B.

ASSEMBLE THE LOWER HOUSING ON HE STEERING TUBE WITH A TUBE SECTION OF AN ADEQUATE DIAMETER.

Specific tooling

020021Y Front suspension service tool

001330Y Tool for fitting steering seats

Recommended products

AGIP GREASE PV2 Grease for control levers on the engine

White anhydrous-calcium based grease to protect roller bearings; temperature range between -20 °C and +120 °C; NLGI 2; ISO-L-XBCIB2

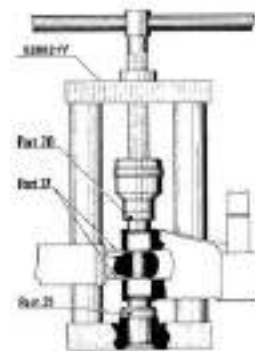

Refitting

When fitting the fork, lubricate with the steering bearing tracks with the recommended grease. Tighten the lower ring nut "A" and the upper ring nut "B" to the specified torque

Recommended products

AGIP GREASE PV2 Grease for steering bearings, pin seats and swinging arm

White anhydrous-calcium based grease to protect roller bearings; temperature range between -20 C and +120 C; with NLGI 2; ISO-L-XBCIB2.

Locking torques (N*m)

Lower steering ring nut 8 to 10 Upper steering ring nut 35 to 40

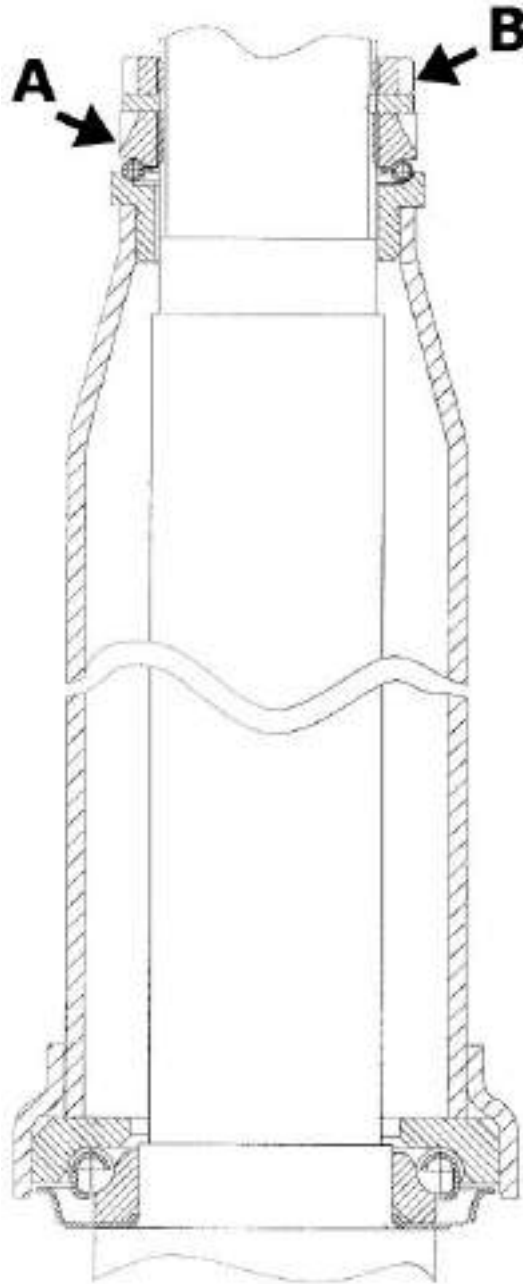

CAUTION

USE NEW ROLLER CASINGS, PIN, SEALING RINGS AND DUST GUARDS FOR REFITTING.

Front shock absorber

Removal

- Remove the steering tube
- Remove the shock absorber lower clamps
- Remove the shock absorber upper clamps



Refitting

To refit, carry out the removal operations in reverse order, observing the prescribed tightening torques.

Locking torques (N*m)

shock absorber lower clamping 20 - 27 shock absorber upper clamp 20 to 30

Shock-absorber - calliper bracket

Removal

- Remove the front wheel hub with the brake disc
- Remove the front shock absorber lower clamps



- Remove the bracket locking Seeger ring
- Unscrew the bracket



-
- Before refitting the bracket in the wheel axle, place the O-ring as shown in the photograph so that it is correctly placed after fitting the bracket.
 - Refit the washer and the Seeger ring.
 - Refit the lower screws fixing the shock absorber to the bracket and tighten at the prescribed torque

**Locking torques (N*m)****Shock absorber lower clamping 20 to 27**

Overhaul

- The bracket for the shock absorber -calliper attachment has two roller bearings separated one from the other as shown in the photograph



- Remove the two roller bearings from the bracket with the specific tool operating on the shock absorber attachment side as shown in the photograph

**Specific tooling****020376Y Adaptor handle****020441Y 26 x 28 mm adaptor****020365Y 22 mm guide**

- Remove the oil seal on the wheel hub side with the screwdriver as shown in the photograph



- Suitably hold the brake calliper - shock absorber attachment bracket
- Fit a new oil seal and move it until it stops using the specific tool

Specific tooling

020376Y Adaptor handle

020360Y 52x55-mm Adaptor



- Assemble a new roller bearing on the shock absorber side and move it until it stops using the specific tool

Specific tooling

020036Y Punch



- Suitably hold the brake calliper - shock absorber attachment bracket
- Assemble a new roller bearing on the wheel hub side and move it until it stops using the specific tool

Specific tooling

020037Y Punch



Refitting

- Refit the parts in reverse order of the removal operation.

CAUTION

BEFORE CARRYING OUT REFITTING OPERATIONS IN THE AREAS MARKED WITH AN ASTERISK, LUBRICATE THEM WITH THE RECOMMENDED PRODUCT

Specific tooling

020036Y Punch

020037Y Punch

Recommended products

AGIP GREASE PV2 Grease for control levers on the engine

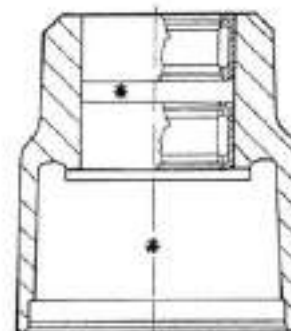

White anhydrous-calcium based grease to protect roller bearings; temperature range between -20 °C and +120 °C; NLGI 2; ISO-L-XBCIB2

Steering bearing

Removal

- Use the specific tool both to remove the lower seat of the upper bearing and to remove the upper seat of the lower bearing fitted on the chassis.

N.B.

TO REMOVE THE LOWER SEAT OF THE LOWER STEERING BEARING JUST USE A SCREW-DRIVER AS A LEVER BETWEEN THE SEATING AND THE SLEEVE.

Specific tooling

020004Y Punch for removing steering bearings from headstock

- Remove the fifth wheel fitting and the dust gaiter on the steering bearing as shown in figure, using the specific tool. Proceed giving a few taps with the mallet.



Specific tooling

020004Y Punch for removing steering bearings from headstock

- Refit the fifth wheel fitting and the dust gaiter on the steering bearing until they stop, using the specific tool.

Specific tooling

006029Y Punch for fitting fifth steering bearing on steering tube



Rear

Removing the rear wheel

- Straighten the cotter pin and remove the cap.
 - Remove the wheel acting on the central fixing point.
-

Refitting the rear wheel

- Fit the wheel, tighten the nut to the prescribed torque.
- Refit the cap and the cotter pin folding it correctly as shown in the figure.

Locking torques (N*m)

Locking torque 137 to 152 Nm

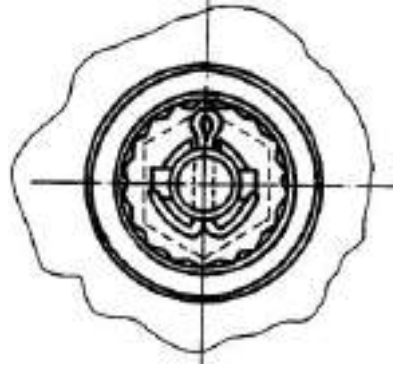

Swing-arm



Removal

Remove the swinging arm acting on the three clamps shown in the figure.





Refitting

For rifting, respect the locking torques

Locking torques (N*m)

Part C 33 to 41 Part B 44 to 52 Part A 33 to 41

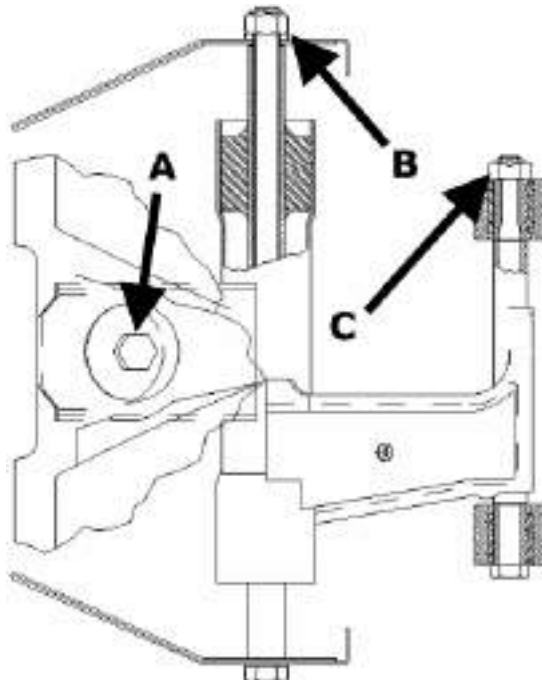

Shock absorbers

Removal

- To replace the shock absorber remove the battery access flap to reach and remove the shock absorber/ frame anchoring nut. Then remove the shock absorber/engine anchorage nut.

- When refitting, tighten the shock absorber/chassis anchoring nut and the shock absorber/engine pin to the prescribed torque.

Locking torques (N*m)

Shock absorber/engine pin torque 33 to 41 N-m

Shock absorber/chassis nut torque 20 to 25 Nm

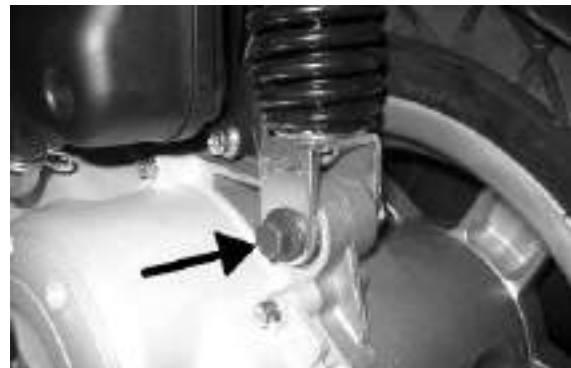

INDEX OF TOPICS

BRAKING SYSTEM

BRAK SYS

1. Tank cover.
- 2 - Pump body.
- 3 - Brake lever.
- 4 - Pump plunger.
- 5- Oil delivery hose.
- 6 - Protection cap for air bleed screw.
- 7- Calliper.
- 8- Dust guard
- 9- Piston sealing ring.
- 10- Piston.
- 11 - Brake pad.
- 12 - Brake disc.

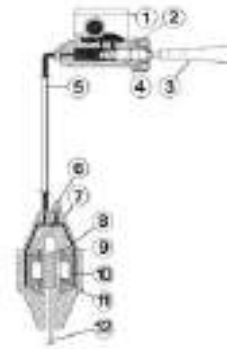

Front brake calliper

Removal

- Detach the oil brake hose from calliper, pouring the fluid inside a container.
- Remove the mountings indicated in the figure.
- When refitting, tighten the nuts to the prescribed torque.
- Bleed the system.



Locking torques (N*m)

Calliper tightening screw 20 ÷ 25 Nm **Brake fluid tube calliper** 20 ÷ 25

Overhaul

- Remove the calliper assembling bolts and take out the internal bodies and components. If necessary, in order to make it easier to take out the plungers, inject (shorts blasts of) compressed air through the brake fluid pipe.
- Check that the cylinders of the internal and external body of the calliper do not show scratches or signs of erosion; otherwise, replace the entire calliper.

CAUTION

ALL THE INTERNAL COMPONENTS MUST BE REPLACED EVERY TIME THE CALLIPER IS SERVICED.

Fit to the calliper body:

- the sealing rings (1-2);
- the plungers (3);

- bed the O-Ring gasket (4) on a calliper body.
- Couple the internal body with the external one with assembling bolts. Refitting the pads and purging air (see previous sections).
- Place the calliper on the disc and lock it to the support by tightening the bolts.
- Lock the pipe joint to the calliper to the prescribed torque.

Upon fitting, the parts must be perfectly clean and **free of traces of oil, diesel fuel, grease**, etc.. They should be washed thoroughly in denatured alcohol before proceeding.

The sealing rings must be immersed in the operating liquid; the use of the PRF1 protection is tolerated.

CAUTION

RUBBER PARTS SHOULD NEVER BE LEFT IN ALCOHOL FOR LONGER THAN 20 SECONDS. AFTER WASHING, THE PIECES MUST BE DRIED WITH A BLAST OF COMPRESSED AIR AND A CLEAN CLOTH.

Locking torques (N*m)

Screw tightening calliper to support 20 to 25 Attachment to the calliper 25 ÷ 30 Nm

- 1 DUST GUARDS
- 2 SEALING RINGS
- 3 PLUNGERS
- 4 O-RING GASKET

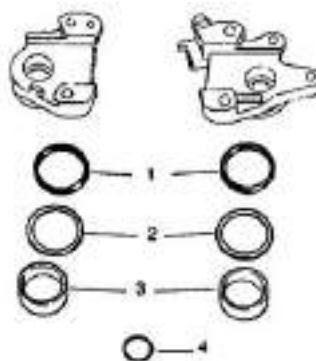

Front brake disc

Removal

- Should the brake disc be replaced, when refitting the hub, apply recommended product on the fixing bolts.

Tighten to the specified torque.

N.B.

THE SURFACE OF THE DISC WITH THE STAMPED ARROW INDICATING THE DIRECTION OF ROTATION MUST FACE THE SHOCK ABSORBER.

Recommended products

Loctite 242 product description

Apply LOCTITE medium type 242 threadlock

Locking torques (N*m)

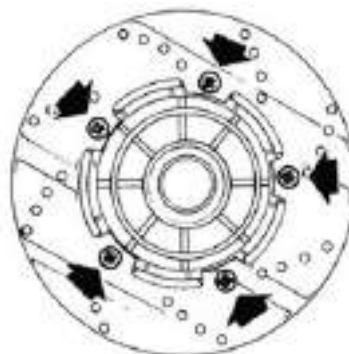

tightening torque 5 to 6.5 Nm

Disc Inspection

Specific tooling

020335Y Magnetic mounting for dial gauge

Characteristic

Max oscillation allowed

0.1 mm.

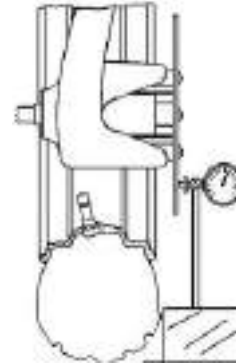

Front brake pads

Removal

- Pads must be replaced when the friction material thickness reaches the wear limit.

- To replace:

remove the protection cover, the bolt and the leaf spring. Slide off the pads and replace them once the plungers are down. Carry out these operations in reverse order to fit.



CAUTION

BEFORE USING THE BRAKE, OPERATE THE LEVER A FEW TIMES.

Front

-Once the bleed valve is closed, fill the system with brake liquid to the maximum level.

-Undo the bleed screw.

-Apply the tube of the special tool to the bleed screws.

When bleeding it is necessary to fill the oil tank in continuation while working with a MITYVAC pump on the bleed screws until no more air comes out of the system.

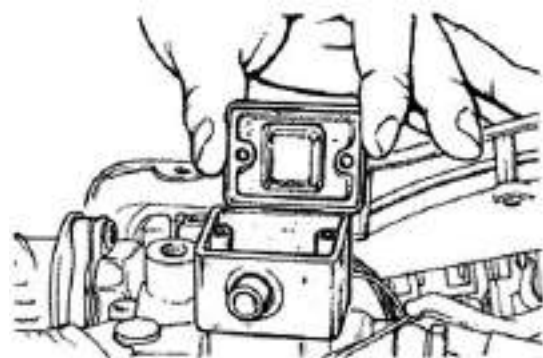

The operation is finished when just oil comes out of the bleed screws.

-Do up the bleed screw.

-When the operation is over, tighten up the oil bleed screw to the prescribed torque.

N.B.

IF AIR CONTINUES TO COME OUT DURING PURGING, EXAMINE ALL THE FITTINGS: IF SAID FITTINGS DO NOT SHOW SIGNS OF BEING FAULTY, LOOK FOR THE AIR INPUT AMONG THE VARIOUS SEALS ON THE PUMP AND CALLIPER PISTONS.

CAUTION

- DURING THE OPERATIONS, THE VEHICLE MUST BE ON THE STAND AND LEVEL.

N.B.

DURING PURGING FREQUENTLY CHECK THE LEVEL TO PREVENT AIR GETTING INTO THE SYSTEM THROUGH THE PUMP.

WARNING

- BRAKING CIRCUIT FLUID IS HYGROSCOPIC. IT ABSORBS HUMIDITY FROM THE SURROUNDING AIR. IF THE LEVEL OF HUMIDITY IN THE BRAKING FLUID EXCEEDS A GIVEN VALUE, BRAKING EFFICIENCY WILL BE REDUCED.

THEREFORE, ALWAYS USE FLUID FROM SEALED CONTAINERS.

UNDER NORMAL DRIVING AND CLIMATIC CONDITIONS YOU SHOULD CHANGE THIS LIQUID EVERY TWO YEARS. IF THE BRAKES ARE USED INTENSELY AND/OR IN HARSH CONDITIONS, CHANGE THE FLUID MORE FREQUENTLY.

CAUTION

WHEN CARRYING OUT THE OPERATION, BRAKE FLUID MAY LEAK FROM BETWEEN THE BLEED SCREW AND ITS SEAT ON THE CALLIPER.

CAREFULLY DRY THE CALLIPER AND DEGREASE THE DISC SHOULD THERE BE OIL ON IT.

Specific tooling

020329Y Mity-Vac vacuum-operated pump

Recommended products

AGIP BRAKE 4 Brake fluid

FMVSS DOT 4 Synthetic fluid

Locking torques (N*m)

Oil bleed screw 7 to 10

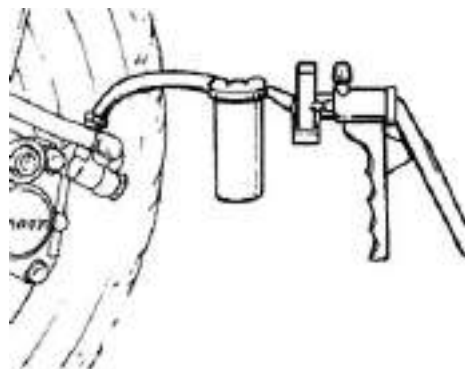

Front brake pump

Removal

- Bleed the circuit and drain the brake fluid through the bleeding screw located on the calliper and actuate the brake lever until no more fluid flows out.
- Remove the oil pump from the handlebar; remove the brake lever and then remove the wheel cylinder.

- 1 - Tank cap screw.
- 2. Tank cover.
- 3. Diaphragm.
- 4. Bellows.
- 5. Sealing ring.
- 6. Piston.
- 7. Gasket.
- 8 - Spring

CAUTION

- THE PRESENCE OF BRAKE FLUID ON THE DISC OR BRAKE PADS REDUCES THE BRAKING EFFICIENCY. IN THIS CASE, REPLACE THE PADS AND CLEAN THE DISC WITH A HIGH-QUALITY SOLVENT. CONTACT WITH BRAKE FLUID WILL DAMAGE PAINTED SURFACES.
RUBBER PARTS SHOULD NEVER BE LEFT IN ALCOHOL FOR LONGER THAN 20 SECONDS.
AFTER WASHING, THE PIECES MUST BE DRIED WITH A BLAST OF COMPRESSED AIR AND A CLEAN CLOTH.
THE SEALING RINGS MUST BE IMMERSSED IN THE OPERATING LIQUID.

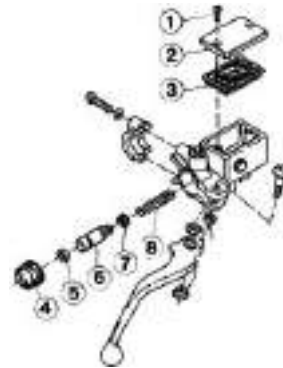

Refitting

Before fitting, the parts must be perfectly clean and free of traces of oil, diesel fuel, grease, etc.. They should be washed thoroughly in denatured alcohol before proceeding.

- Reinstall the individual parts in the reverse order to the removal, paying attention to the correct positioning of the rubber parts in order to ensure leak tightness.

- 1 - Tank cap screw.
- 2. Tank cover.
- 3. Diaphragm.
- 4. Bellows.

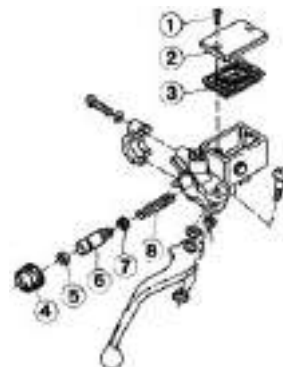

5. Sealing ring.
6. Piston.
7. Gasket.
8. Spring.

Rear drum brake

Once the silencer and the wheel have been removed, follow these steps:

1. Remove the shoe spring using the specific spanner.
2. Remove the shoe with the aid of a lever.
3. Refit the new shoes giving a few taps with the mallet.
4. Attach the spring using the specific pliers.

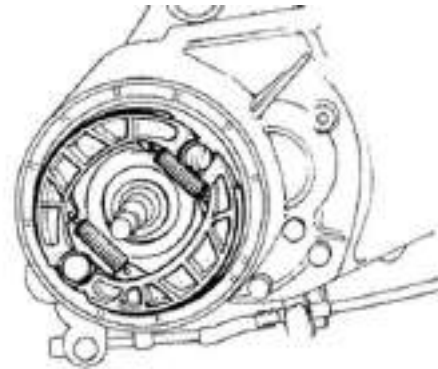

Specific tooling

020325Y Pliers for brake-shoe springs

INDEX OF TOPICS

CHASSIS

CHAS

Seat

-
- Lift the saddle and remove the helmet compartment «A».



-
- Undo the two screws indicated.



Rear handlebar cover

-
- Remove the front handlebar cover.
 - Undo the three screws indicated in figure fixing it to the handlebar, the odometer transmission and the electrical connectors.

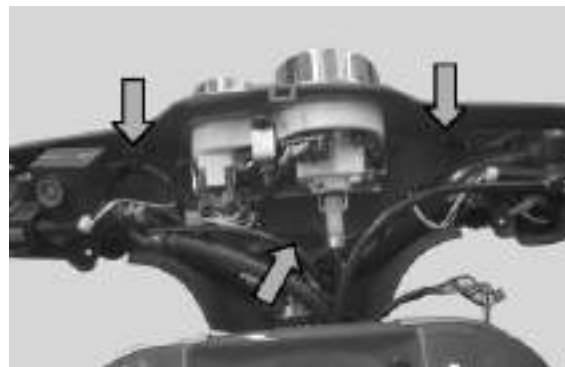

Instrument panel

- Remove the rear handlebar cover.
- Undo the three screws indicated fixing the rear handlebar cover.



Front handlebar cover

Proceed as follows:

- Remove the rear-view mirrors.
- Undo the two screws «A».



- Undo the screw «B» and remove the front handlebar cover.



- Disconnect the electrical terminals and remove the turn indicator bulb.



Headlight assy.

- Remove the front handlebar cover.
- Undo the four screws indicated fixing the front handlebar cover.



Knee-guard

- Undo the five screws indicated.



- Remove the rubber strip from both sides and undo the indicated screw.

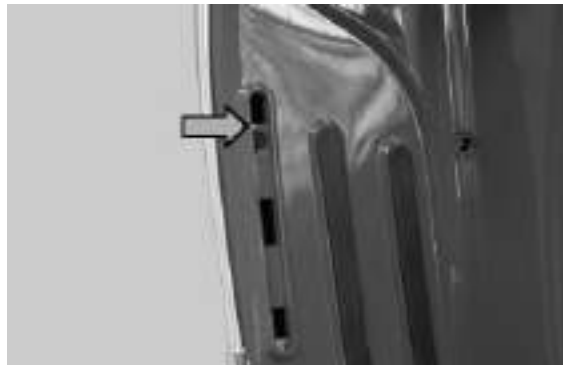

- Remove the leg shield back plate bringing it to the rear part of the vehicle.



Taillight assy.

- Undo the two fixing screws and remove the rear light unit.



- Undo the screw indicated and disconnect the connector.



Footrest

- Remove the leg shield back plate.
 - Remove the side fairings.
 - Remove the central tunnel inspection door.
- From both sides, unscrew:
- The fixing screw at the back.

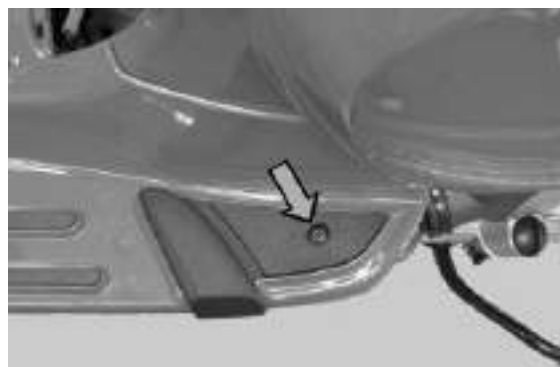

- The fixing screw on the central part.

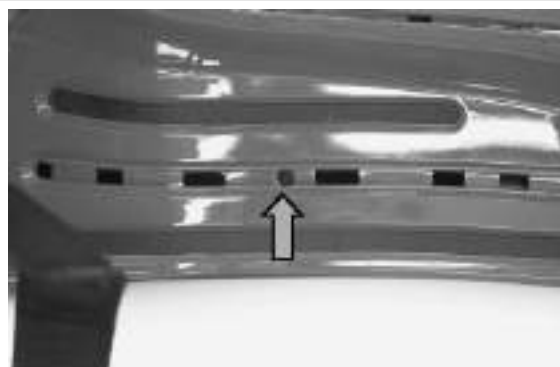

-
- The fixing screw at the front.

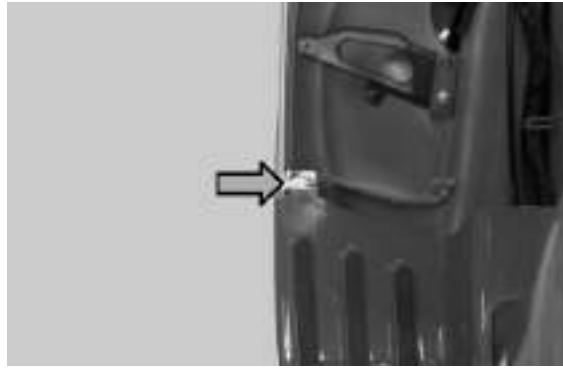

-
- Remove the footrest.



Side fairings

-
- Undo the screw «A» and the smaller screw «B».

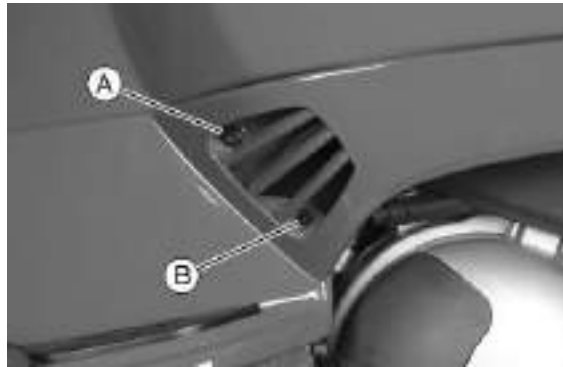

-
- Detach the seats on the fairing.



License plate holder

- Remove the side fairings.
- Working on both sides, undo the two screws indicated.

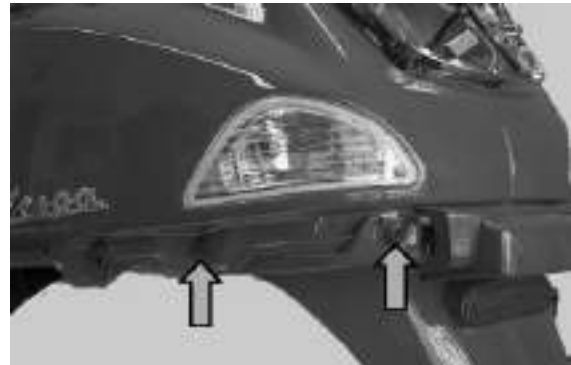

-
- Remove the license plate light.

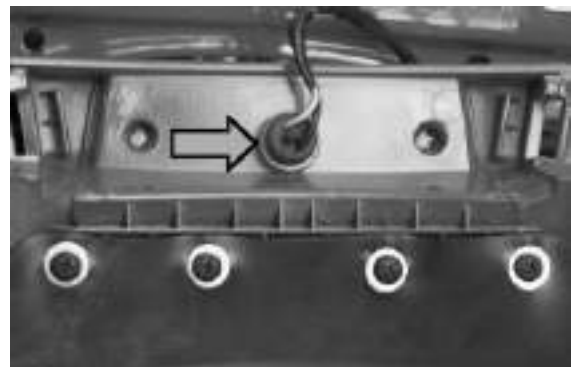

Air filter

- Remove the helmet compartment.
- Remove the side fairings.
- Undo the two indicated clamps to the crankcase.



-
- Undo the two clamps indicated.

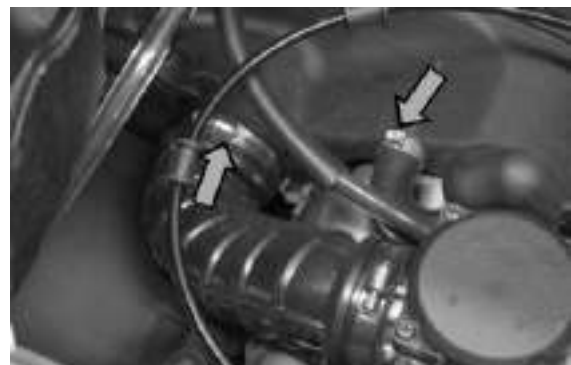

Fuel tank

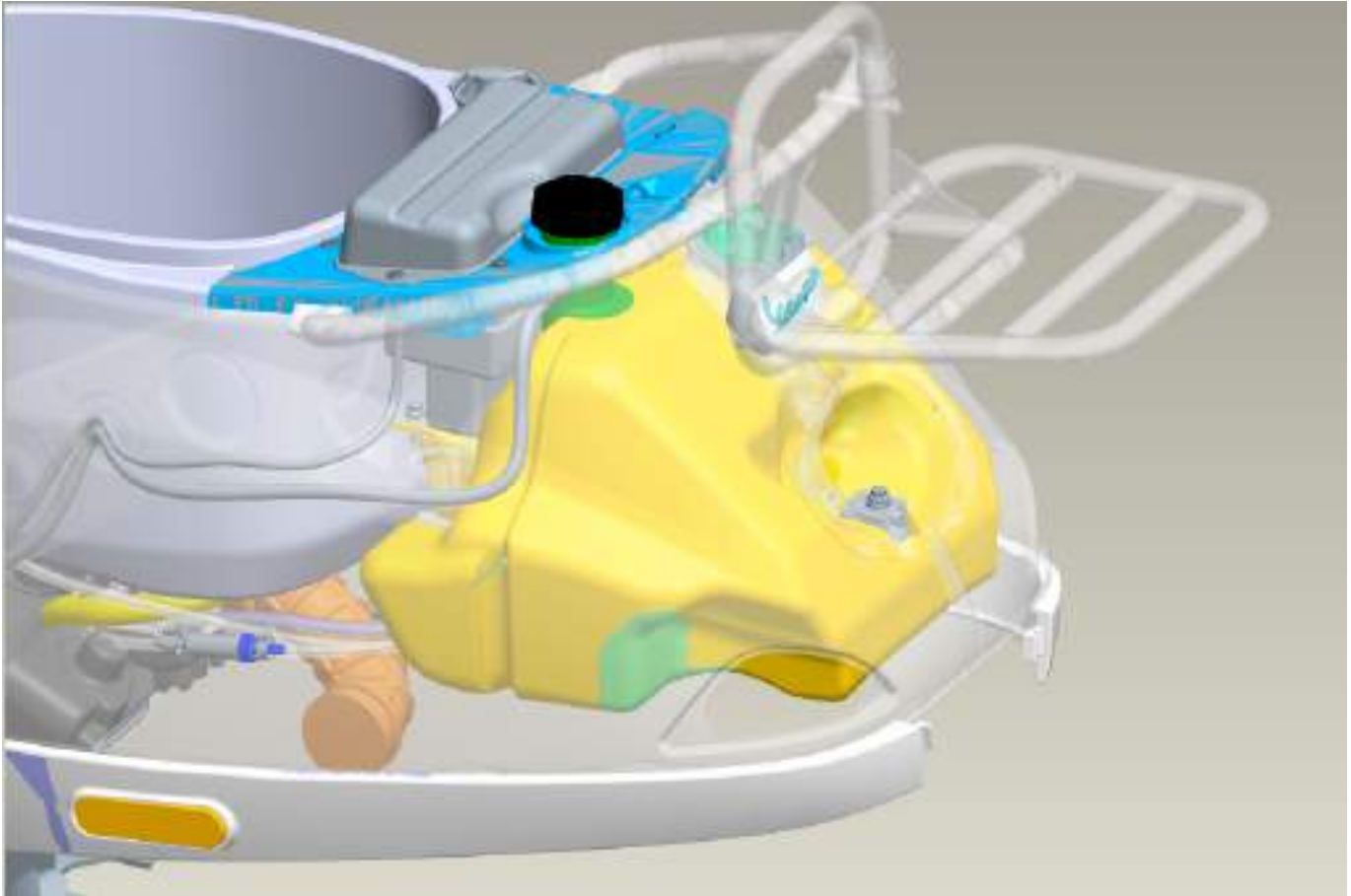

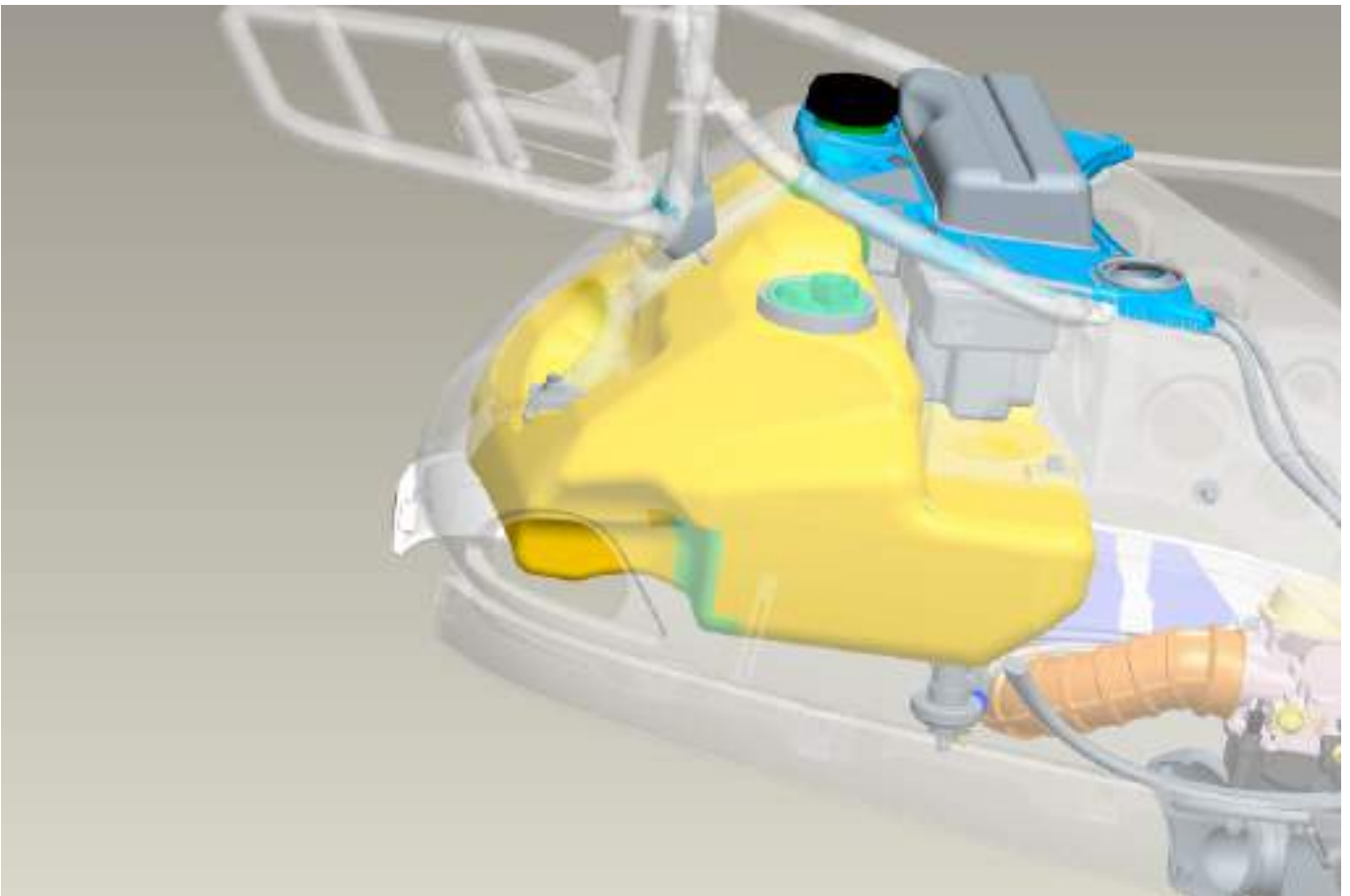

- Adequately support the rear part of the vehicle.
- Remove the wheel and the rear mudguard.
- Remove the battery compartment.
- Disconnect the fuel exhaust pipe.
- Undo the two fixing screws to the chassis and collect the fuel pipe supporting plate.

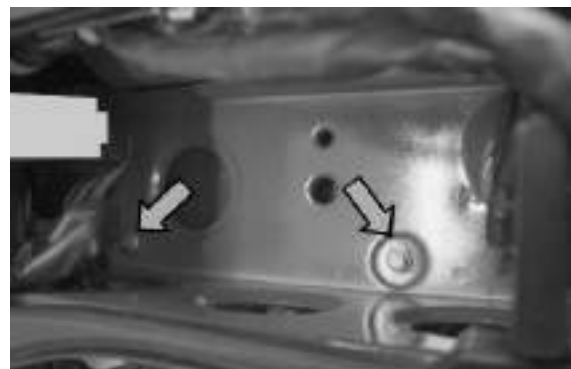

-
- Remove the turn indicators.
 - Remove the rear light unit and undo the indicated screw.



-
- Unscrew the closing cap.
 - Lower the fuel tank and disconnect the bleed pipes and the level indicator connector.



-
- Remove the tank.



Front mudguard

- First remove the steering tube and uncouple the front brake pipes from the calliper in order to remove the front mudguard
- Remove the three mudguard-steering tube clamps indicated in the figure



Front central cover

- Remove the "Piaggio" clip-on badge.



- Undo the two screws indicated.

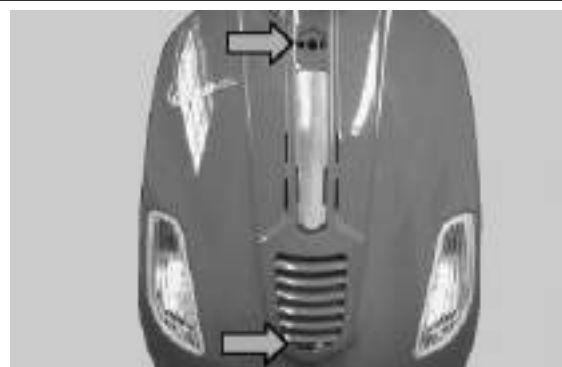

- Remove the front central cover, sliding it upwards.

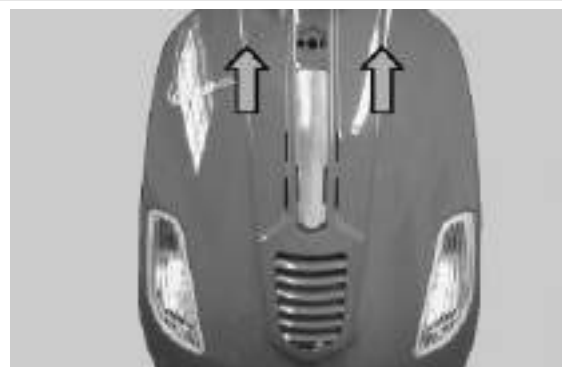

INDEX OF TOPICS

PRE-DELIVERY

PRE DE

Aesthetic inspection

- Paintwork
- Fitting plastics parts
- Damage
- Dirt

Tightening torques inspection

Lock check

- All tightening torques
- External screw of covers

SAFETY FASTENERS

Name	Torque in Nm
Handlebar locking	40 to 50
Lower steering ring nut	8 to 10
Upper steering ring nut	30 to 40
Front wheel axle nut	75 to 90
Rear wheel nut	137 to 152
Rear shock absorber nut-engine	33 to 41 N·m
Shock absorber - chassis nut	20 to 25
Engine-swinging arm bolt	33 to 41
Frame-swinging arm bolt	44 to 52

Electrical system

- Check voltage at pre-delivery; it should be 12.6V minimum; otherwise, recharge the battery following the specifications indicated on the battery itself.

Check the following devices:

- Key switch
- Low beam light, high beam light, light warning lights, position light
- Headlight adjustment
- Rear light
- Stop light (front and rear brake, if required)
- Turn indicators and relevant warning lights
- Speedometer and instrument panel lighting
- Horn
- Starter button

CAUTION

IN ORDER TO ENSURE MAXIMUM PERFORMANCE CHARGE THE BATTERY BEFORE USE ONLY IF VOLTAGE DROPS BELOW 12.7 V. FAILURE TO CHARGE THE BATTERY ADEQUATELY BEFORE IT IS FIRST USED SHORTENS BATTERY LIFE.

WHEN INSTALLING THE BATTERY, ATTACH THE POSITIVE LEAD FIRST AND THEN THE NEGATIVE LEAD.

NEVER USE FUSES WITH A CAPACITY HIGHER THAN THE RECOMMENDED CAPACITY. USING A FUSE OF UNSUITABLE RATING MAY SERIOUSLY DAMAGE THE VEHICLE OR EVEN CAUSE A FIRE.

WARNING

KEEP THE BATTERY AWAY FROM NAKED FLAMES OR SPARKS WHILE IT IS CHARGED. REMOVE THE BATTERY FROM THE VEHICLE, DISCONNECTING THE NEGATIVE TERMINAL FIRST.

ALWAYS WEAR EYE PROTECTION WHEN WORKING IN THE PROXIMITY OF BATTERIES. KEEP OUT OF THE REACH OF CHILDREN. BATTERY ELECTROLYTE IS TOXIC AND IT MAY CAUSE SERIOUS BURNS. IT CONTAINS SULPHURIC ACID. AVOID CONTACT WITH YOUR EYES, SKIN AND CLOTHING. NEVER TRY TO FORCE OR DAMAGE THE OUTER CASING. IN CASE OF CONTACT WITH EYES OR SKIN, RINSE WITH ABUNDANT WATER FOR ABOUT 15 MINUTES AND SEEK MEDICAL ATTENTION AT ONCE.

IF IT ACCIDENTALLY SWALLOWED, IMMEDIATELY DRINK LARGE QUANTITIES OF WATER OR VEGETABLE OIL. SEEK IMMEDIATE MEDICAL ATTENTION.

Levels check

- Brake oil level
 - Hub oil level
 - Engine oil level
-

Road test

- Cold start.
 - Speedometer activation check.
 - Throttle control operation.
 - Riding stability.
 - Front and rear brake efficiency.
 - Front and rear wheel shock absorber efficiency.
 - Abnormal noise.
 - Hot engine restart.
 - Fluid leak (after test drive).
-

Functional inspection

- Brake lever travel.
- Throttle control adjustment and free travel.
- Uniform turning of the steering.

Others

- Tyre pressure
- Correct operation of all locks
- Mirrors and accessories fitting
- Tools supplied, user's manual, warranty certificate and customer services documents

CAUTION

CHECK AND ADJUST TYRE PRESSURE WITH TYRES AT AMBIENT TEMPERATURE.

CAUTION

NEVER EXCEED THE RECOMMENDED INFLATION PRESSURES OR TYRES MAY BURST.

WARNING

HANDLE FUEL WITH CARE.

INDEX OF TOPICS

TIME

TIME

Engine

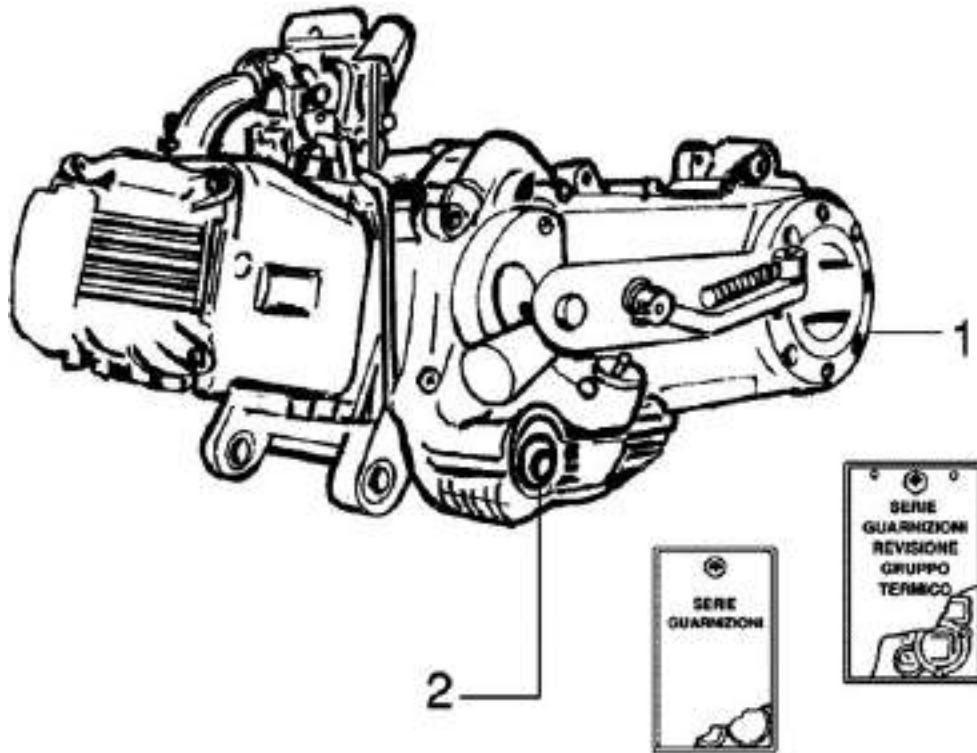

ENGINE

	Code	Action	Duration
1	001001	Engine from chassis - Removal and refit.	
2	003064	Engine oil - change	

Crankcase

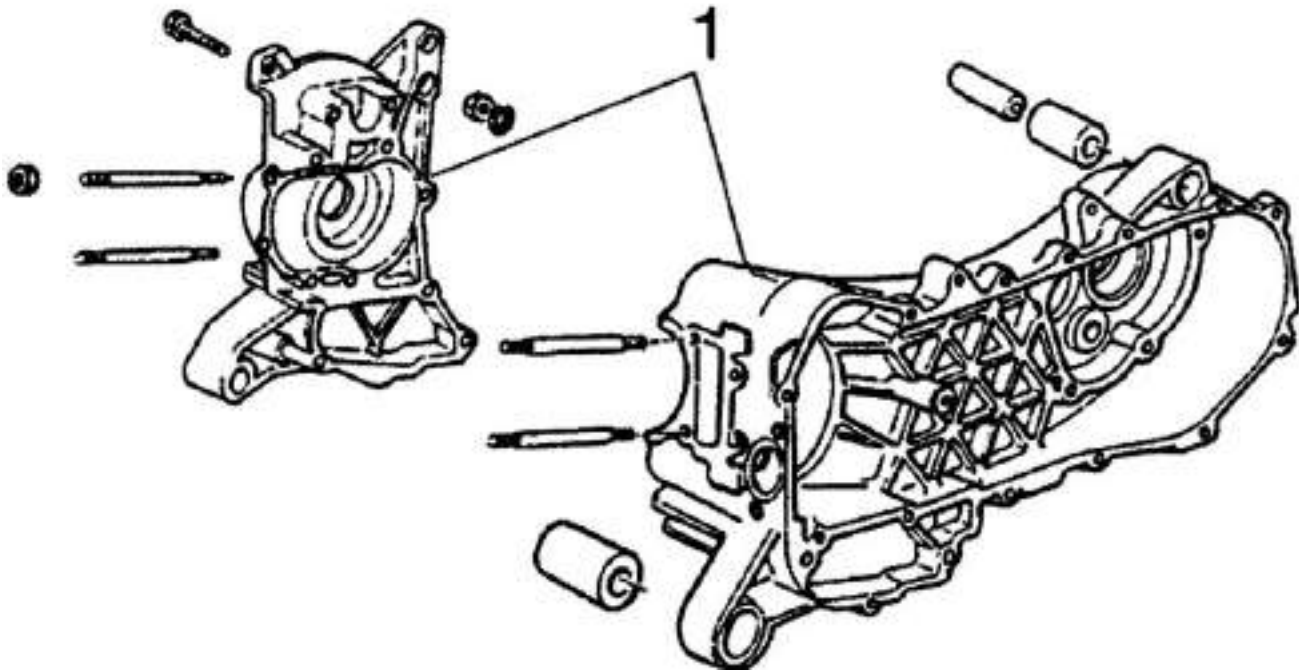

CRANKCASE

	Code	Action	Duration
1	001133	Engine crankcase - Replacement	

Crankshaft

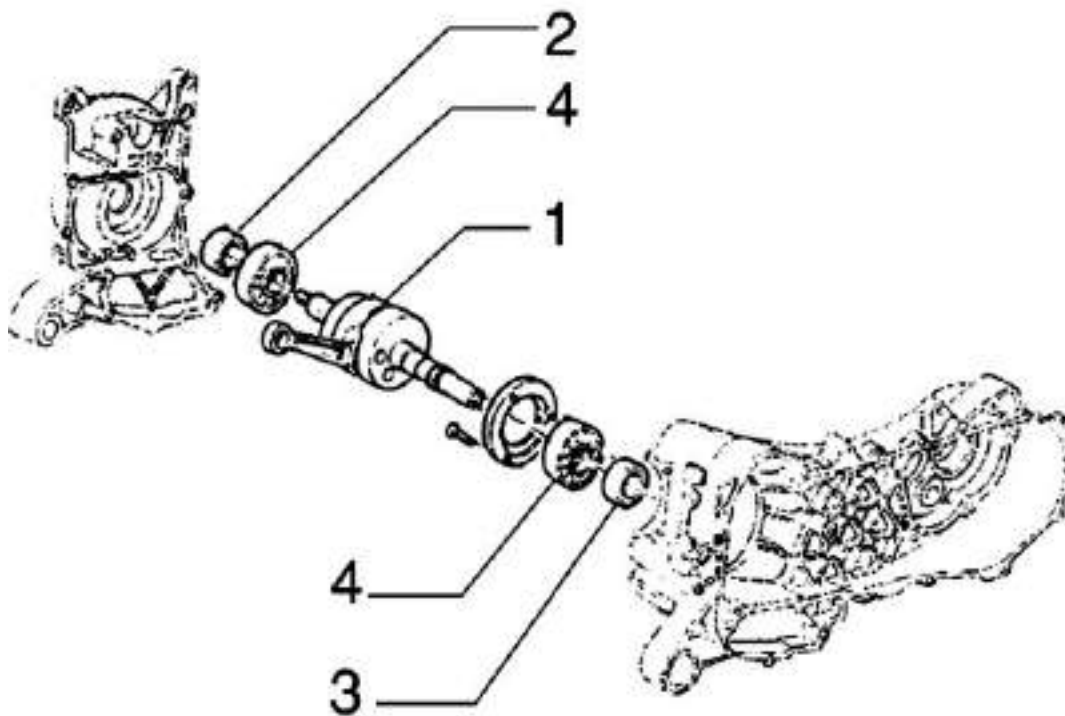

CRANKSHAFT

	Code	Action	Duration
1	001117	Crankshaft - Replacement	
2	001099	Flywheel-side oil seal - Replacement	
3	001100	Clutch-side oil seal - Replacement	
4	001118	Main bearings - Replacement	

Cylinder assy.

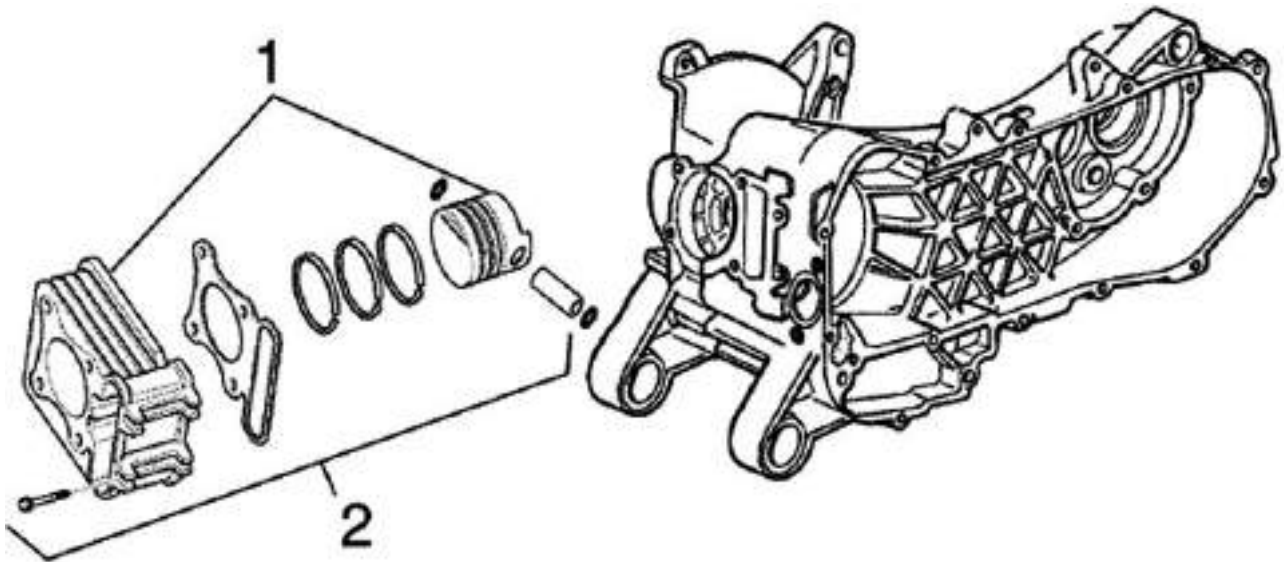

CYLINDER - PISTON

	Code	Action	Duration
1	001002	Cylinder Piston - Replacement	
2	001107	Cylinder Piston - Inspection /Cleaning	

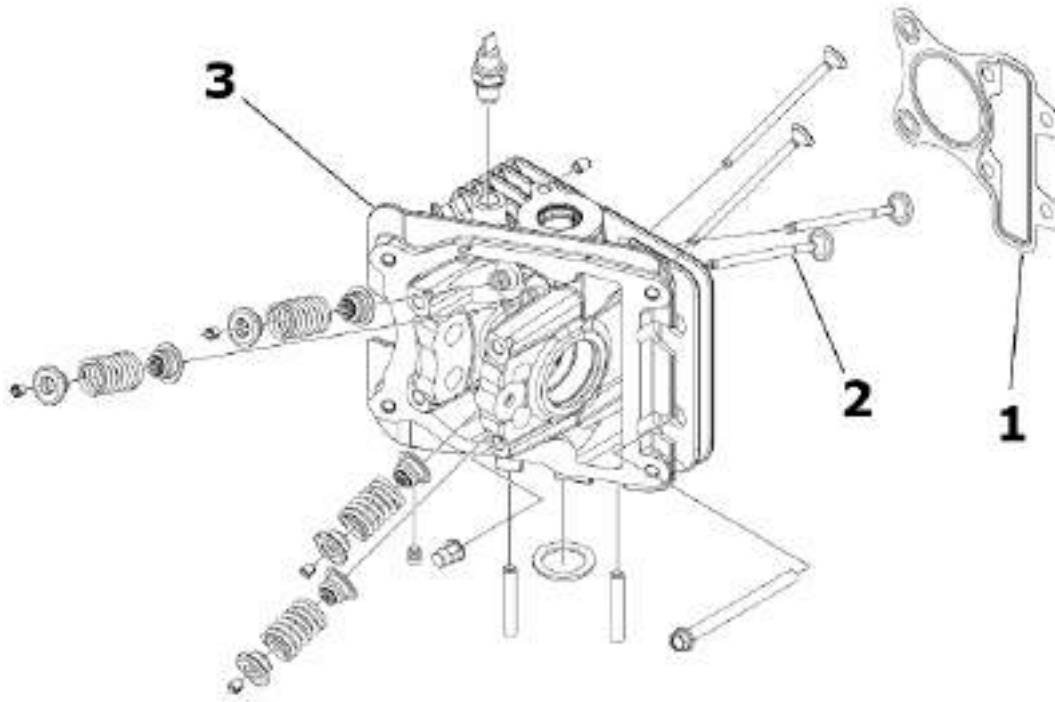
Cylinder head assy.**HEAD**

	Code	Action	Duration
1	001056	Head gasket - change	
2	001045	Valves - Replacement	
3	001126	Head - Replacement	

Rocker arms support assy.

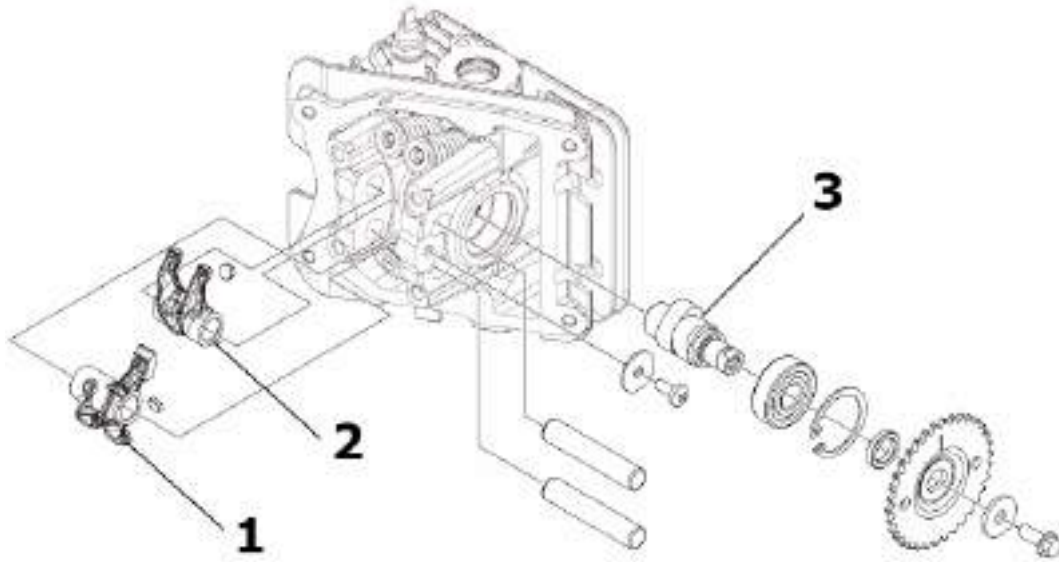

CAMSHAFT SUPPORT

	Code	Action	Duration
1	001049	Valve clearance - Adjustment	
2	001148	Valve rocking levers - Replacement	
3	001044	Camshaft - Replacement	

Cylinder head cover

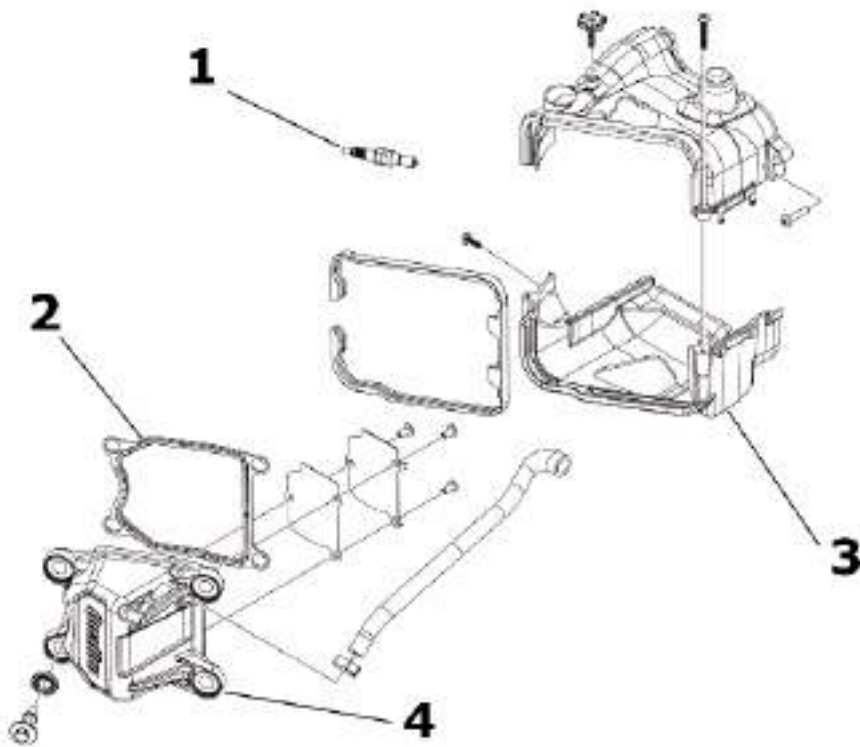
**HEAD COVER**

	Code	Action	Duration
1	001093	Spark plug - Replacement	
2	001088	Head cover gasket - Replacement	
3	001097	Cooling hood - Replacement	
4	001089	Head cover - Replacement	

Driven pulley

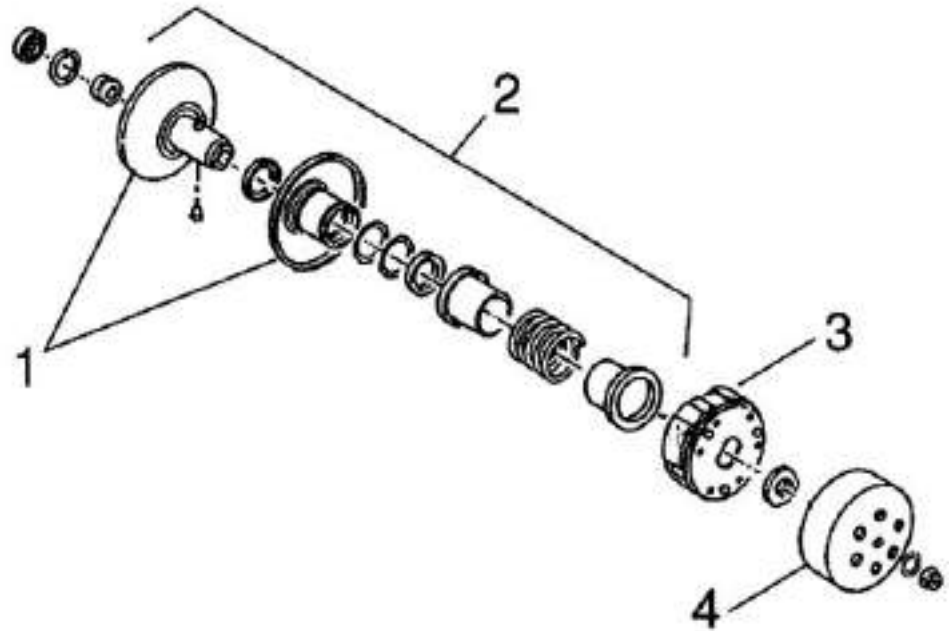

DRIVEN PULLEY - CLUTCH

	Code	Action	Duration
1	001110	Driven pulley- Replacement	
2	001012	Driven pulley - overhaul	
3	001022	Clutch - Replacement	
4	001155	clutch housing - Replacement	

Oil pump

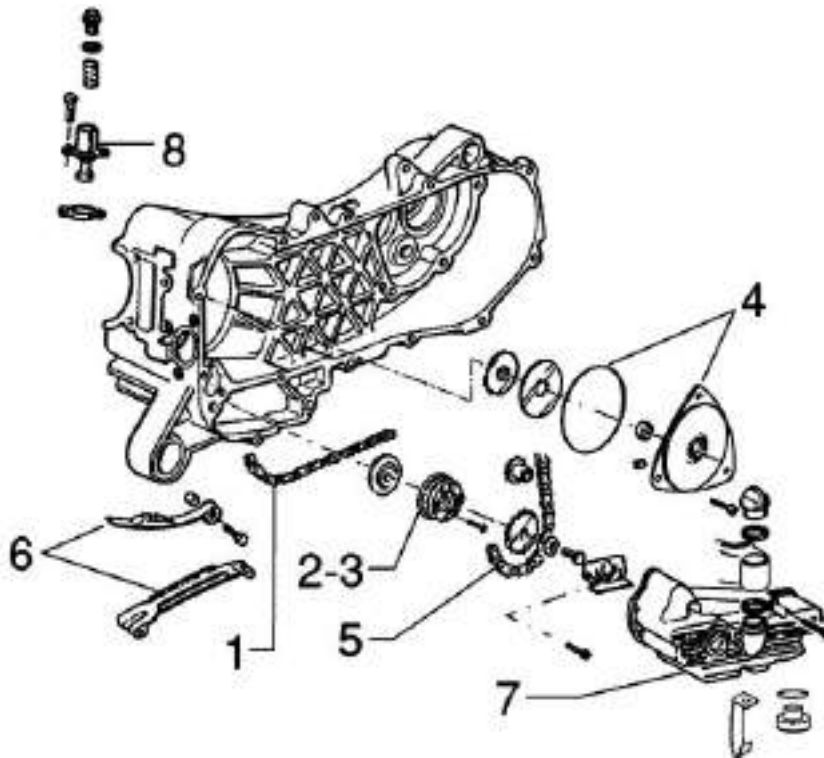

OIL PUMP

	Code	Action	Duration
1	001051	Belt/Timing chain - Change	
2	001112	Oil pump - change	
3	001042	Oil pump - overhaul	
4	001121	Chain cover oil seal - Replacement	
5	001122	Oil pump chain - Replacement	
6	001125	Chain guide pads - Replacement	
7	001130	Oil sump - change	
8	001129	Chain tensioner - Service and Replacement	

Final gear assy.

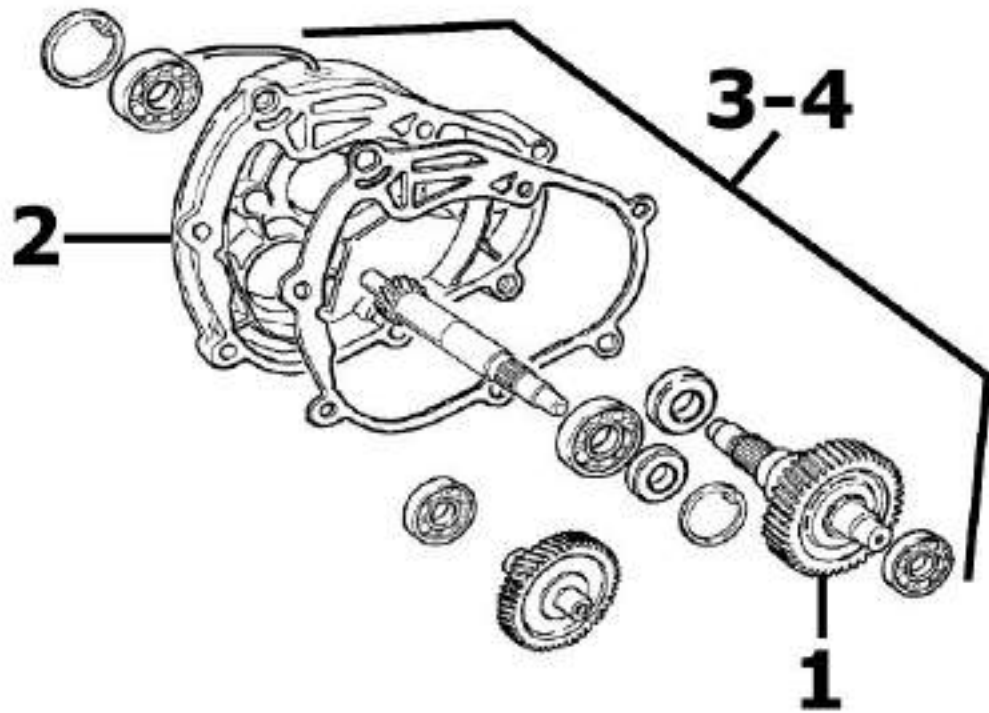

FINAL REDUCTION GEAR

	Code	Action	Duration
1	004125	Rear wheel axle - Replacement	
2	001156	Gear reduction unit cover - Replacement	
3	003065	Gear box oil - Replacement	
4	001010	Geared reduction unit - Service	

Driving pulley

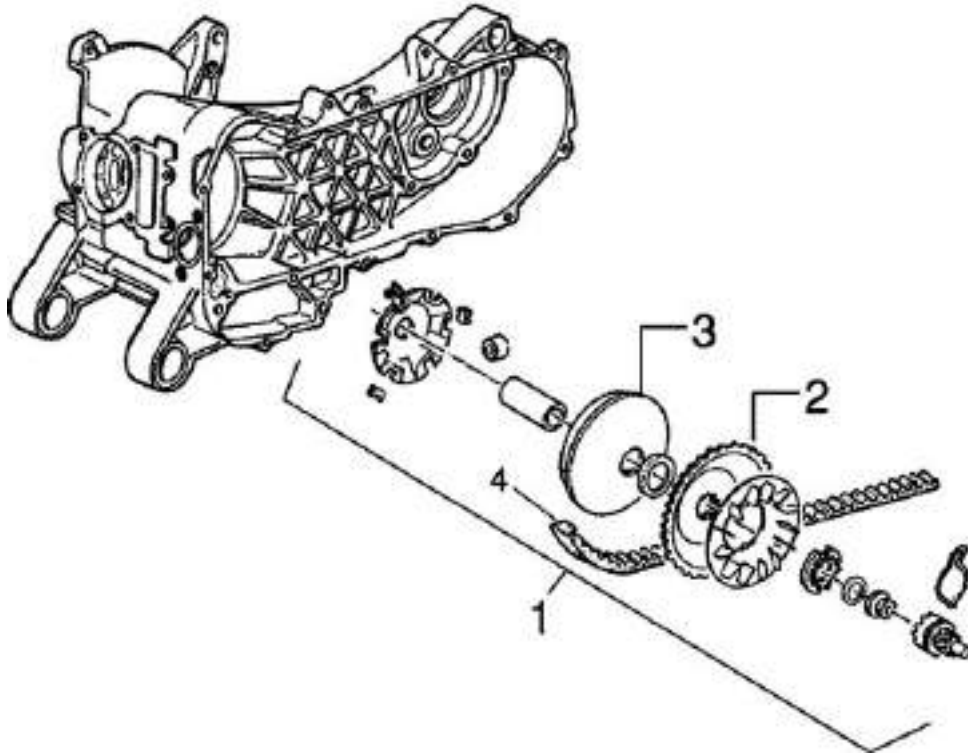

DRIVING PULLEY

	Code	Action	Duration
1	001177	CVT rollers / sliders - Replacement	
2	001086	Driving half-pulley - Replacement	
3	001066	Driving pulley - Removal and refitting	
4	001011	Drive belt - Replacement	

Transmission cover

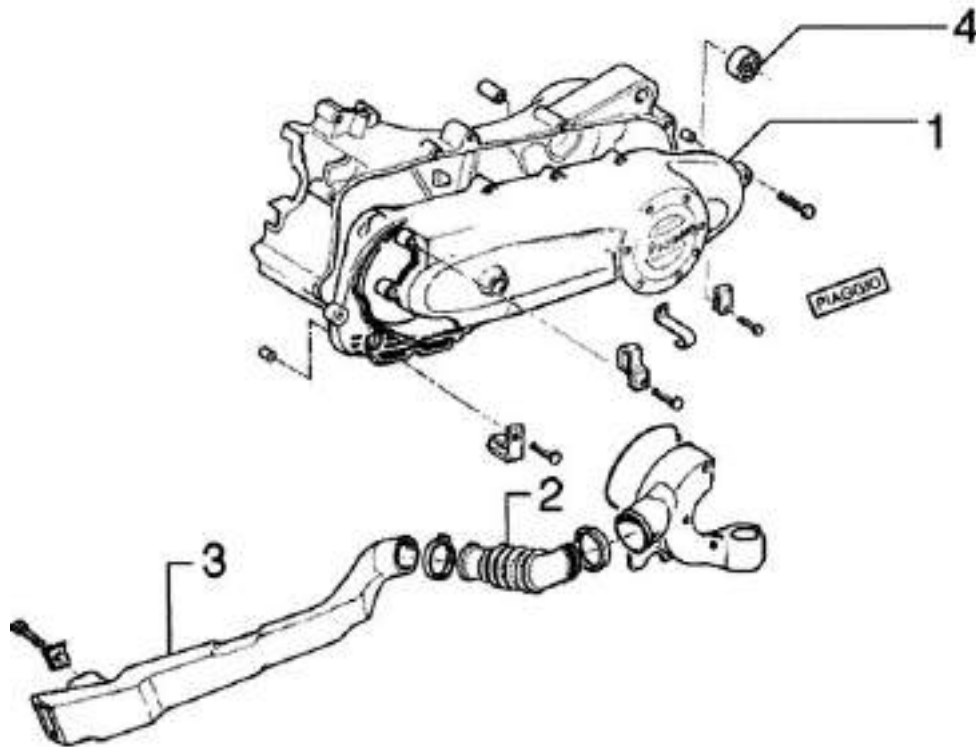

TRANSMISSION COVER

	Code	Action	Duration
1	001096	Transmission crankcase cover - Replacement	
2	001132	Transmission air intake pipe - Replacement	
3	001131	Transmission air intake - Replacement	
4	001135	Transmission cover bearing - Replacement	

Starter motor

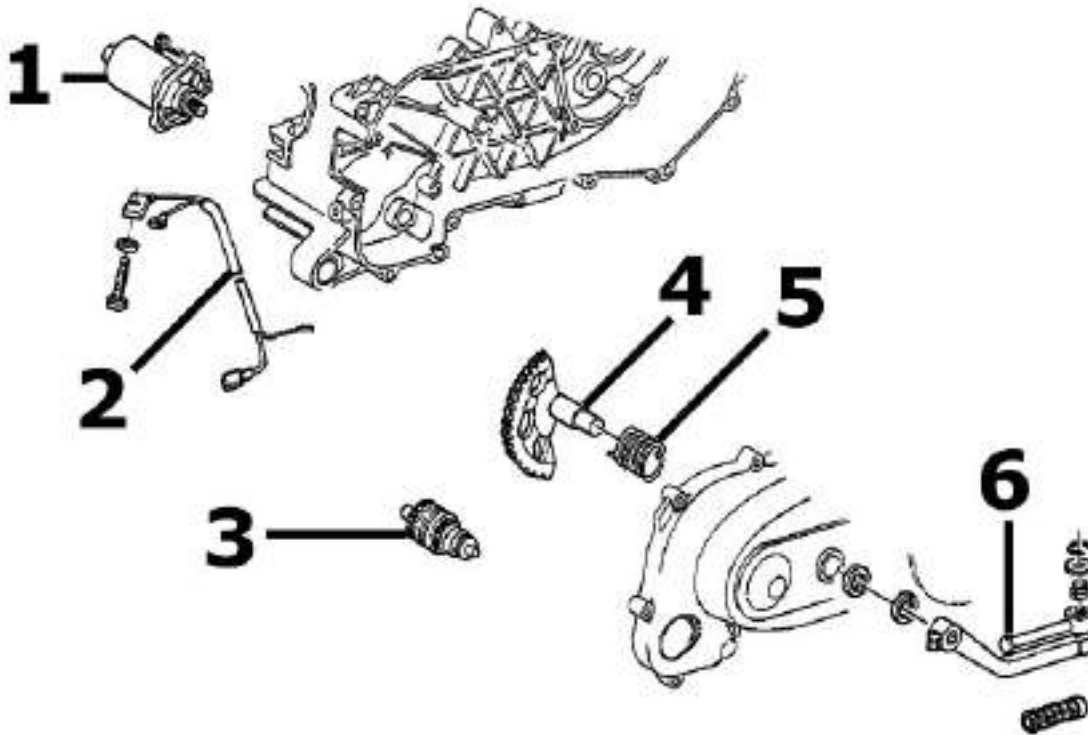

ELECTRIC STARTER

	Code	Action	Duration
1	001020	Starter motor - Replacement	
2	005045	Starter motor cable assembly - Replacement	
3	001017	Start-up pinion - Replacement	
4	001021	Kick starter - Inspection	
5	008008	Starter spring pack - Replacement	
6	001084	Starter lever - Replacement	

Flywheel magneto

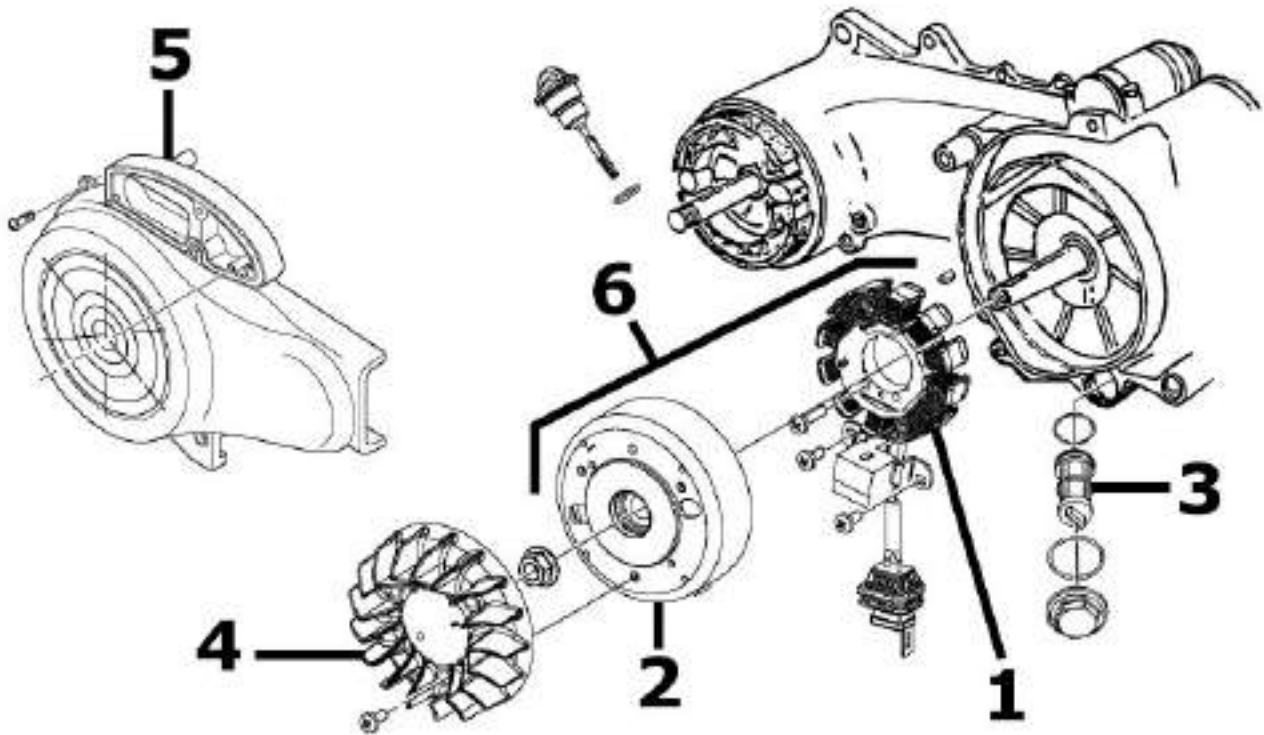

MAGNETO FLYWHEEL

	Code	Action	Duration
1	001067	Stator - Fitting and Refitting	
2	001173	Rotor - Replacement	
3	001102	Net oil filter - change / Cleaning	
4	001109	Cooling fan - Replacement	
5	001087	Flywheel cover - Replacement	
6	001058	Flywheel - Replacement	

Carburettor

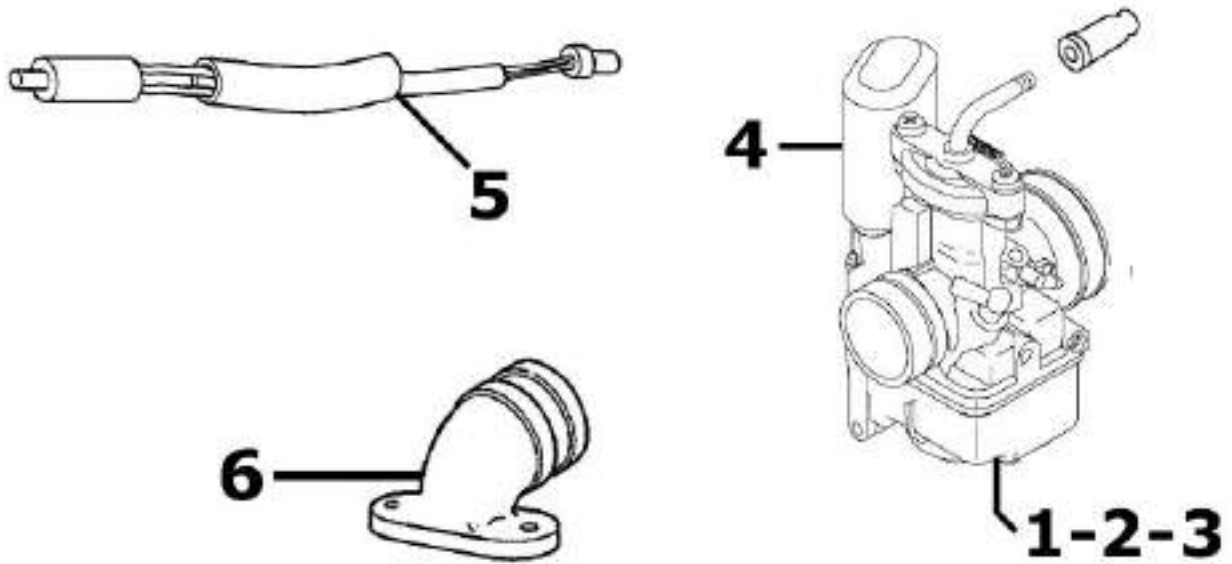

CARBURETTOR

	Code	Action	Duration
1	001063	Carburettor - Replacement	
2	001008	Carburettor - Inspection	
3	003058	Carburettor - Adjustment	
4	001081	Automatic choke - Replacement	
5	001082	Carburettor heating resistor - Replacement	
6	001013	Intake manifold - change	

Exhaust pipe

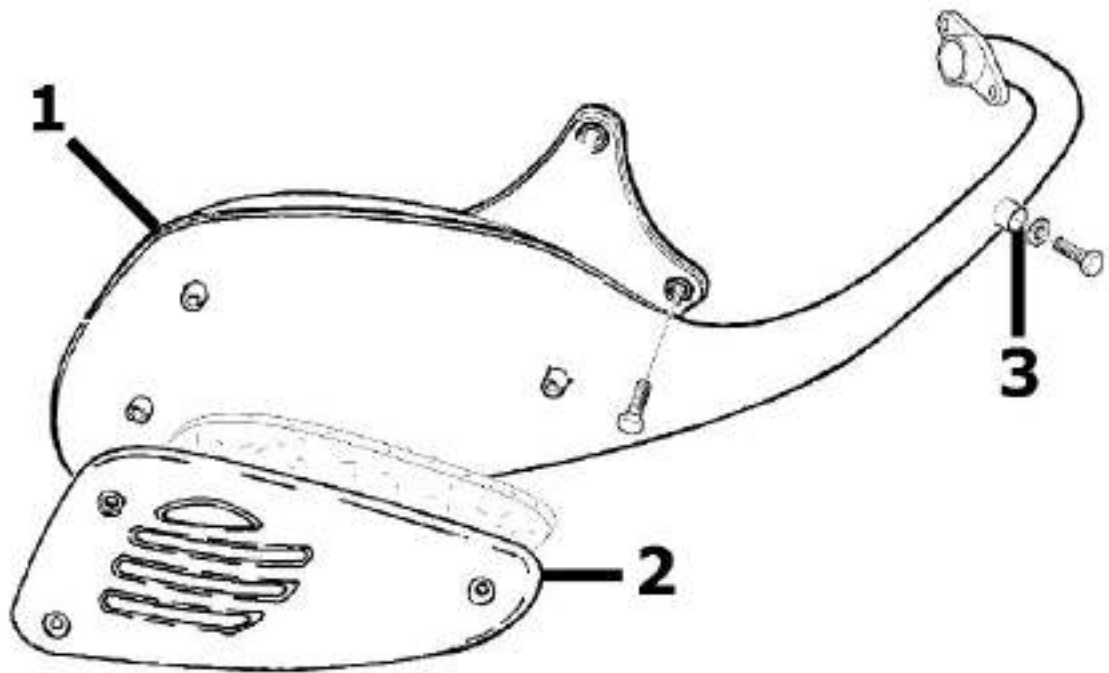

SILENCER

	Code	Action	Duration
1	001009	Silencer - Replacement	
2	001095	Silencer heatshield - Replacement	
3	001136	Exhaust emissions - Adjustment	

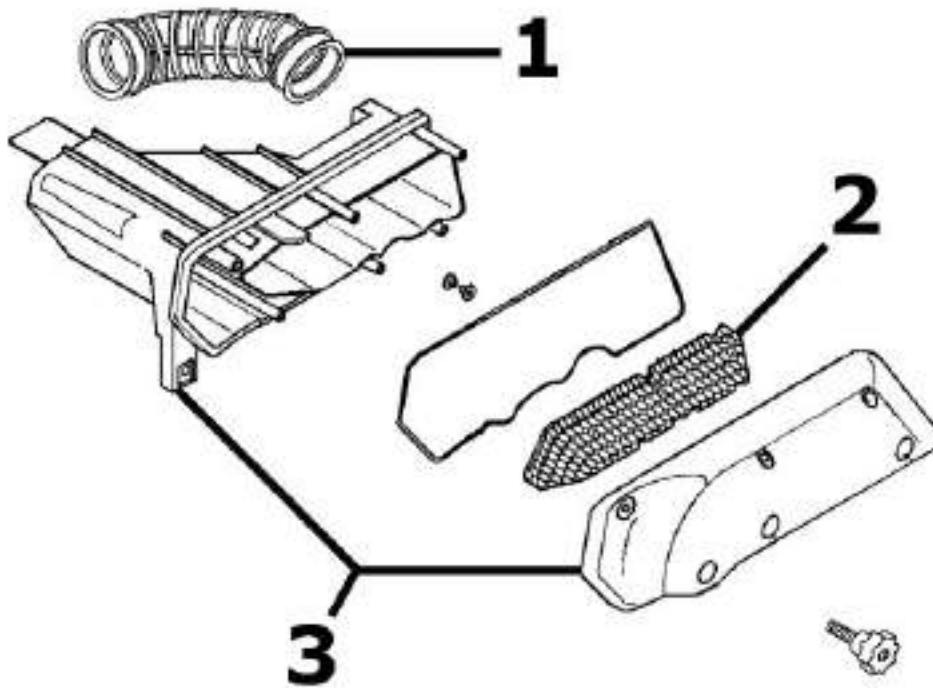
Air cleaner**AIR CLEANER**

	Code	Action	Duration
1	004122	Air cleaner carburettor fitting - Replacement	
2	001014	Air filter - Replacement / cleaning	
3	001015	Air filter box - Replacement	

Frame

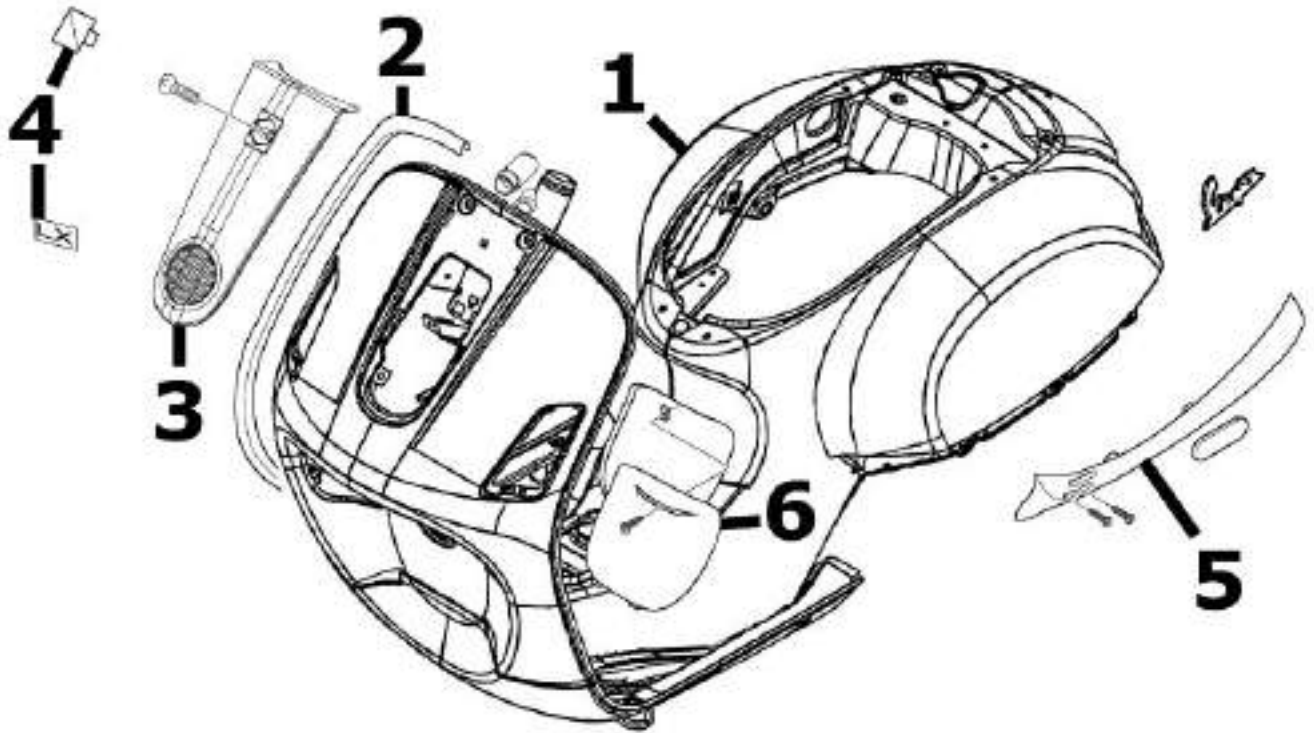

CHASSIS

	Code	Action	Duration
1	004001	Chassis - Replacement	
2	004023	Shield rim - Replacement	
3	004149	Shield central cover - Replacement	
4	004159	Plates / Stickers - Replacement	
5	004012	Rear side panels - Replacement	
6	004059	Spark plug inspection flap - Replacement	

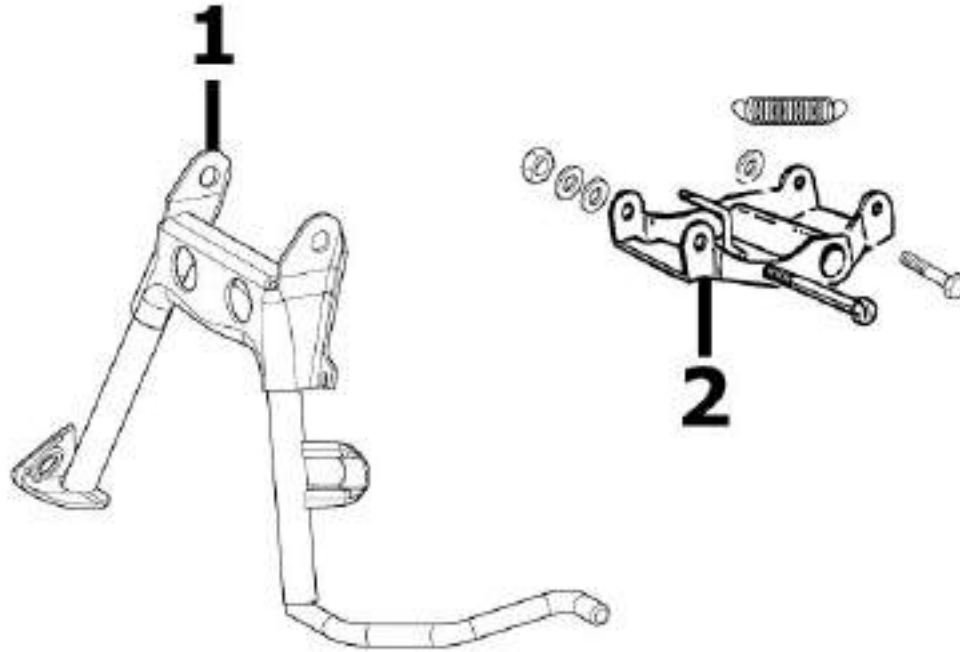
Centre-stand**STAND**

	Code	Action	Duration
1	004004	Stand - Replacement	
2	004171	Stand support plate - Replacement	

Footrests

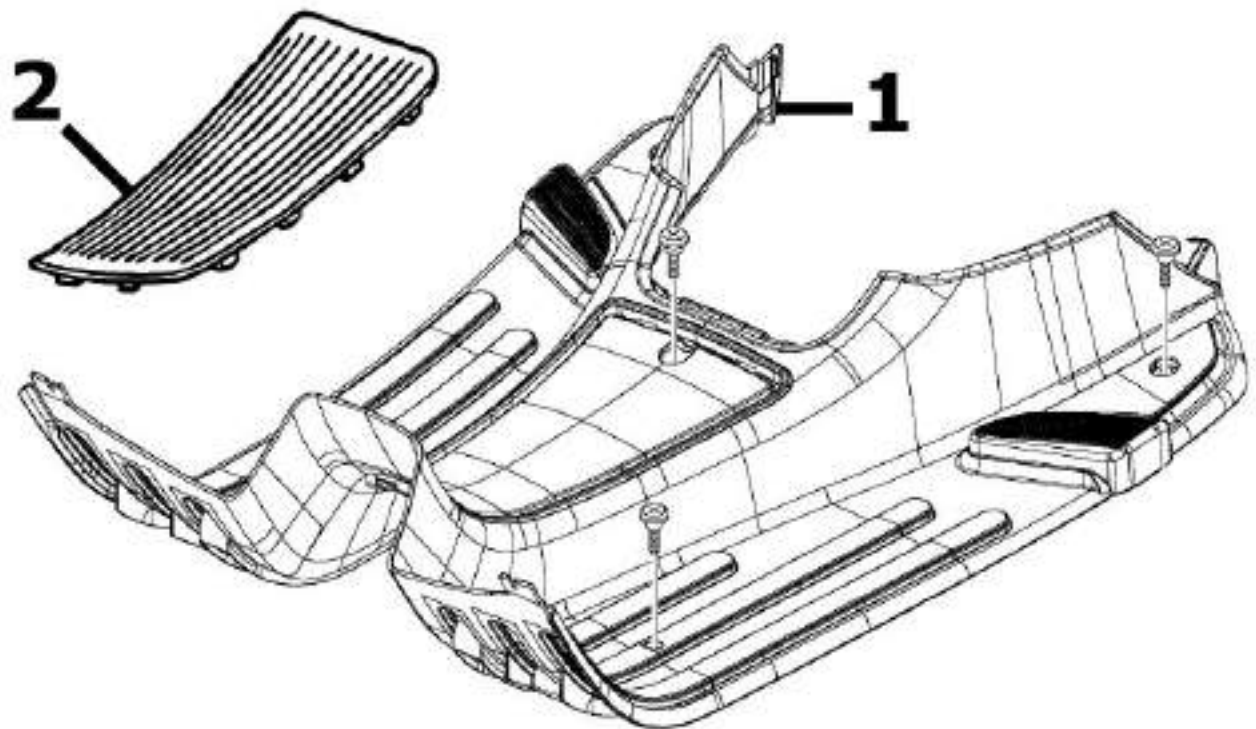

FOOTREST

	Code	Action	Duration
1	004178	Footrest - Replacement	
2	004078	Front/rear footrest rubber - Replacement	

Rear cover

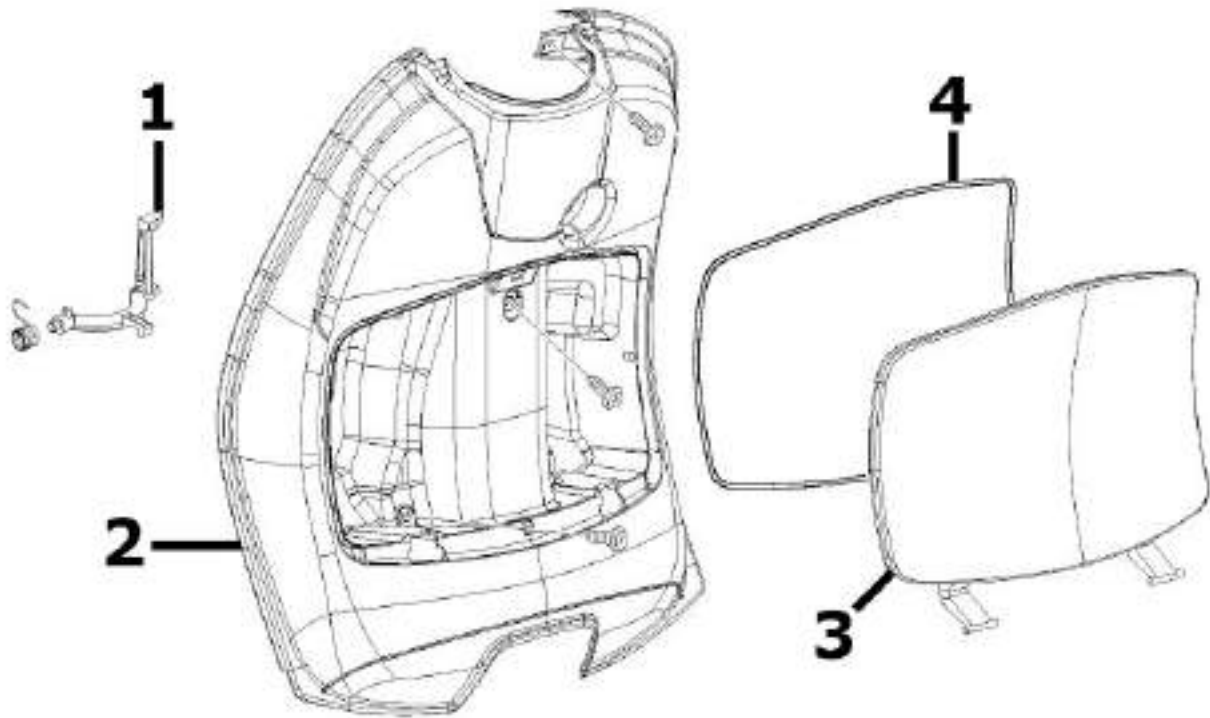
**LEG SHIELD BACK PLATE**

	Code	Action	Duration
1	004174	Trunk levers - Replacement	
2	004065	Legshield, rear part - Removal and refitting	
3	004081	Top box lid - Replacement	
4	004082	Case gasket - Replacement	

Underseat compartment

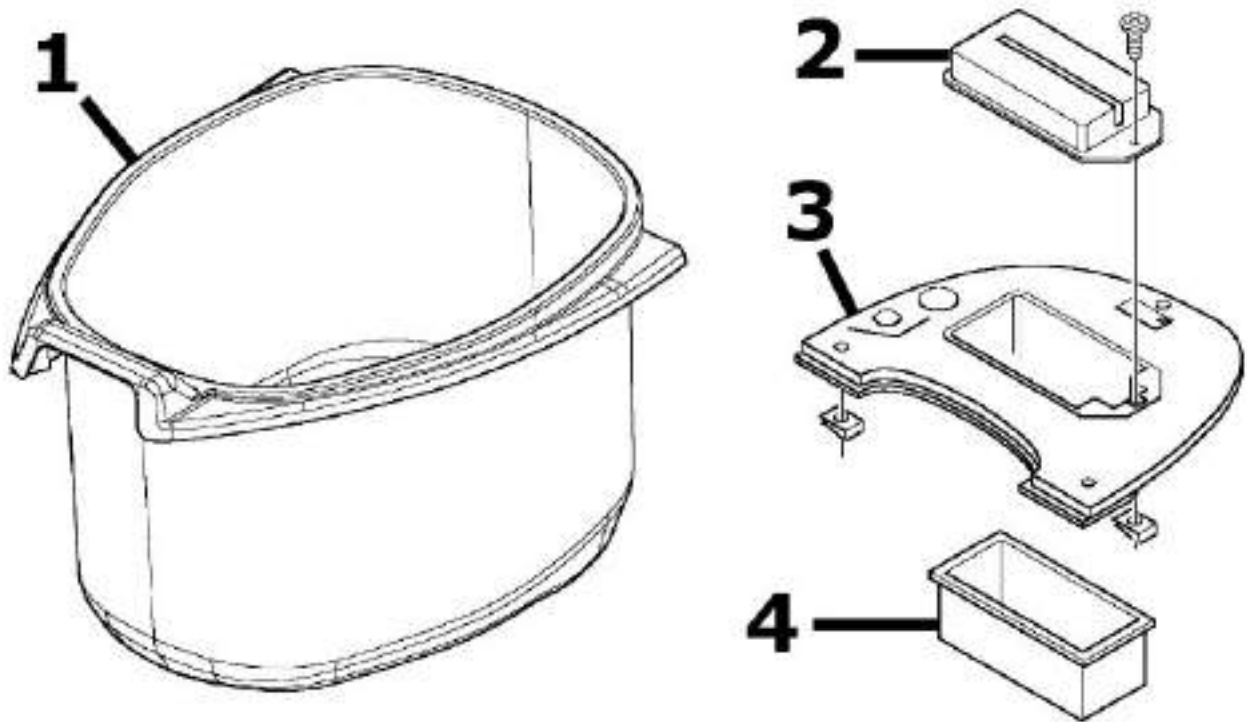

HELMET COMPARTMENT

	Code	Action	Duration
1	004016	Helmet compartment - Replacement	
2	005046	Battery cover - change	
3	004011	Central chassis cover - Replacement	
4	004071	Battery compartment - replacement	

Plate holder

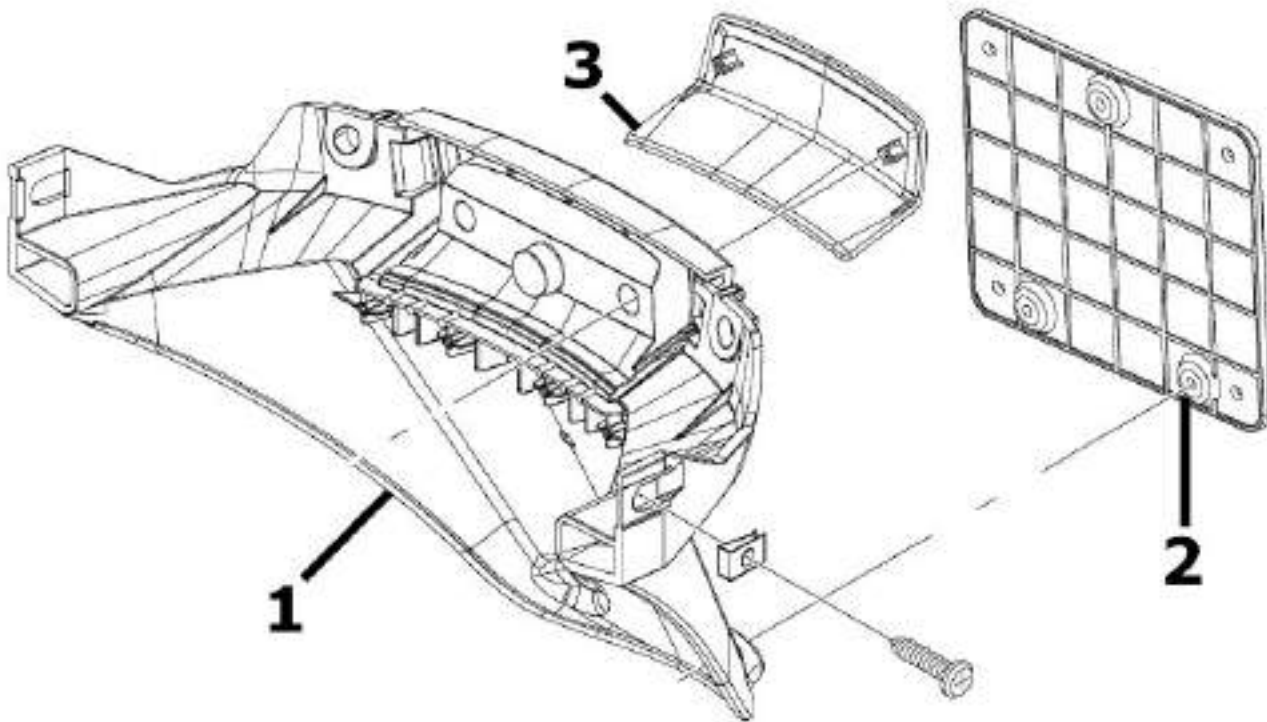

LICENSE PLATE HOLDER

	Code	Action	Duration
1	004136	License plate holder mounting - Replacement	
2	005048	number plate holder - Replacement	
3	005032	number plate light glass - Replacement	

Mudguard

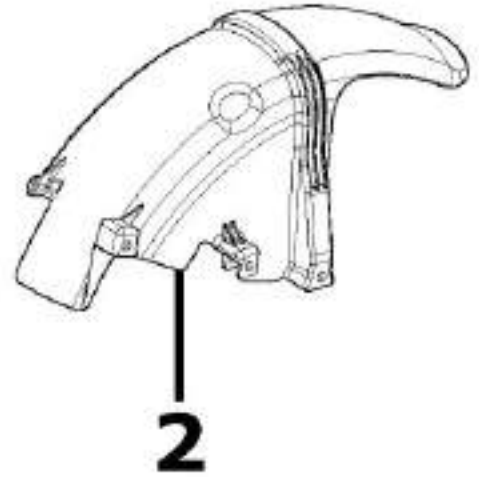
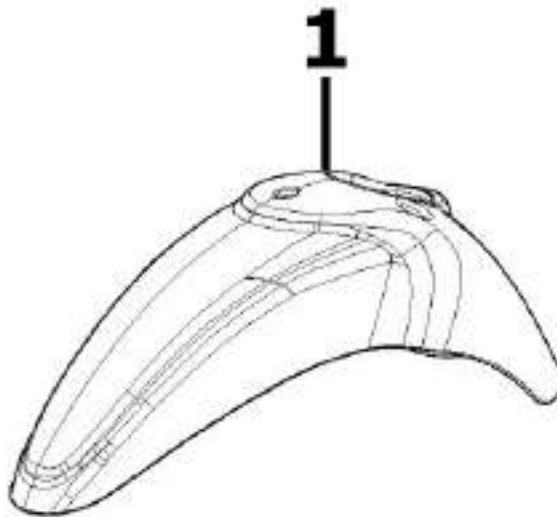

MUDGUARDS

	Code	Action	Duration
1	004002	Front mudguard - change	
2	004009	Rear mudguard - Replacement	

Fuel tank

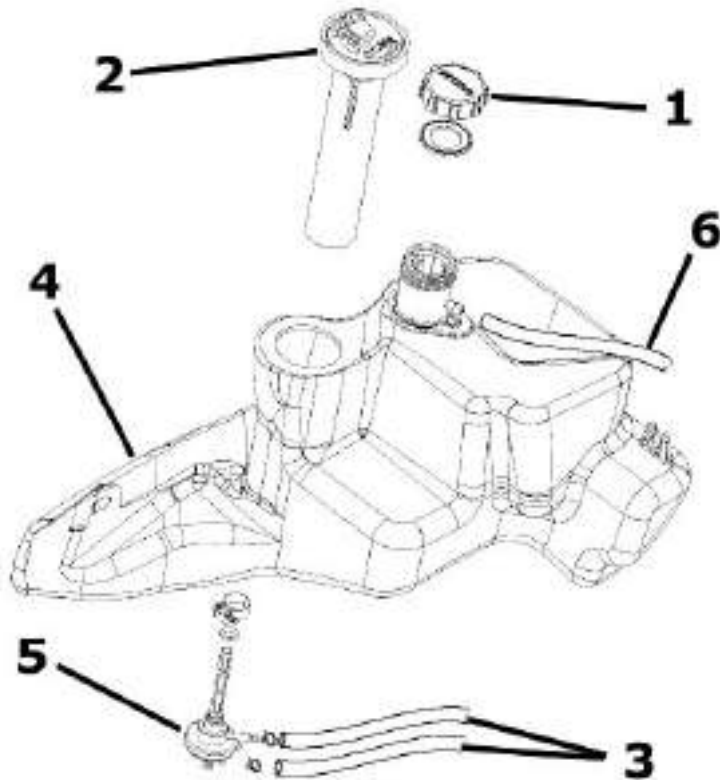
**FUEL TANK**

	Code	Action	Duration
1	004168	Fuel tank cap - Replacement	
2	005010	Tank float - Replacement	
3	004112	Cock-carburettor hose - Replacement	
4	004005	Fuel tank - Replacement	
5	004007	Fuel valve - Replacement	
6	004109	Fuel tank breather - change	

Rear shock-absorber

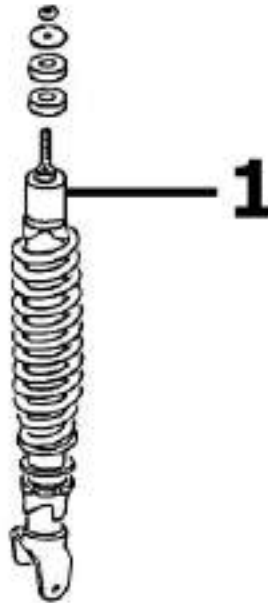

REAR SHOCK ABSORBER

	Code	Action	Duration
1	003007	Rear shock absorber - Removal and Refitting	

Steering column bearings

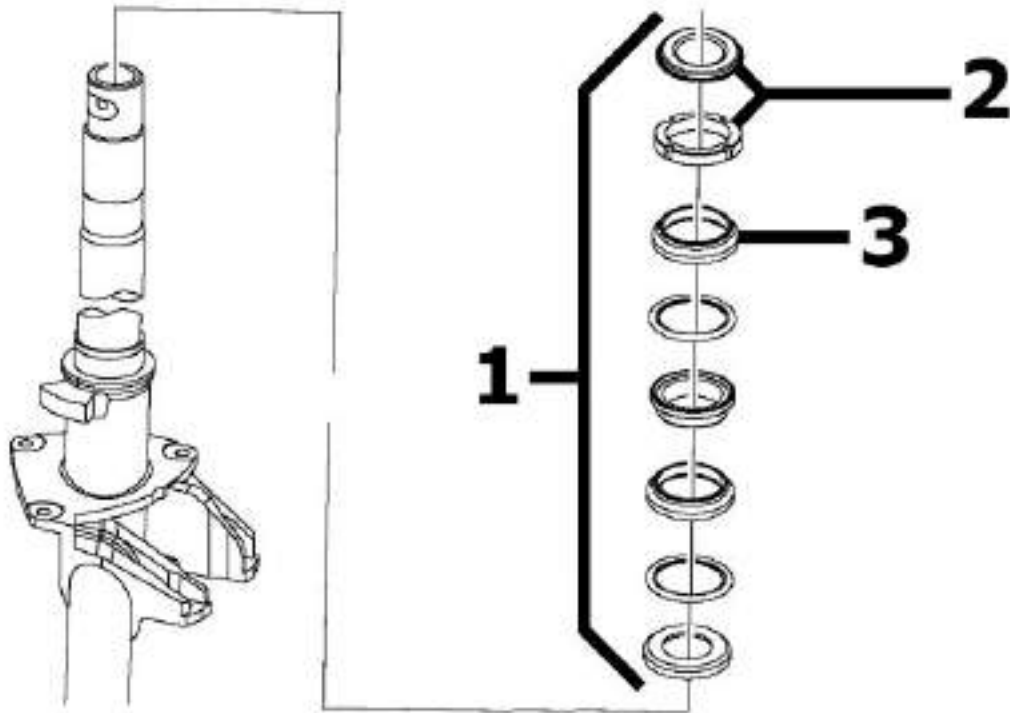

STEERING BEARING

	Code	Action	Duration
1	003002	Steering bearing - Replacement	
2	003073	Steering clearance - Adjustment	
3	004119	Steering Bearing / upper steering bearing - Replacement	

Handlebar covers

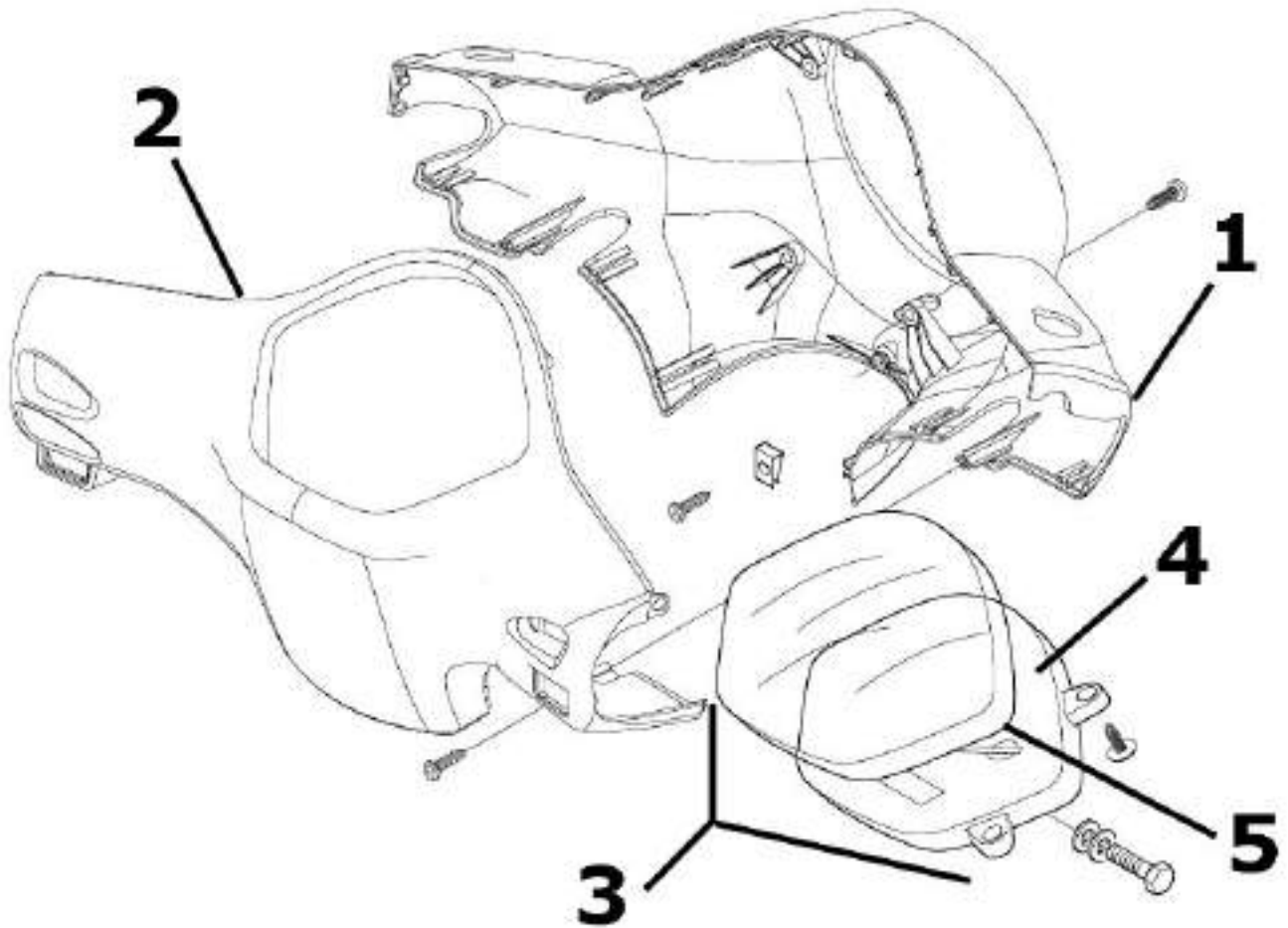

ODOMETER - HANDLEBAR COVERS

	Code	Action	Duration
1	004018	Handlebar front section - Replacement	
2	004019	Handlebar rear section - Replacement	
3	005014	Odometer - Replacement	
4	005038	Instrument panel warning light bulbs - Replacement	
5	005078	Odometer glass - Replacement	

Handlebar components

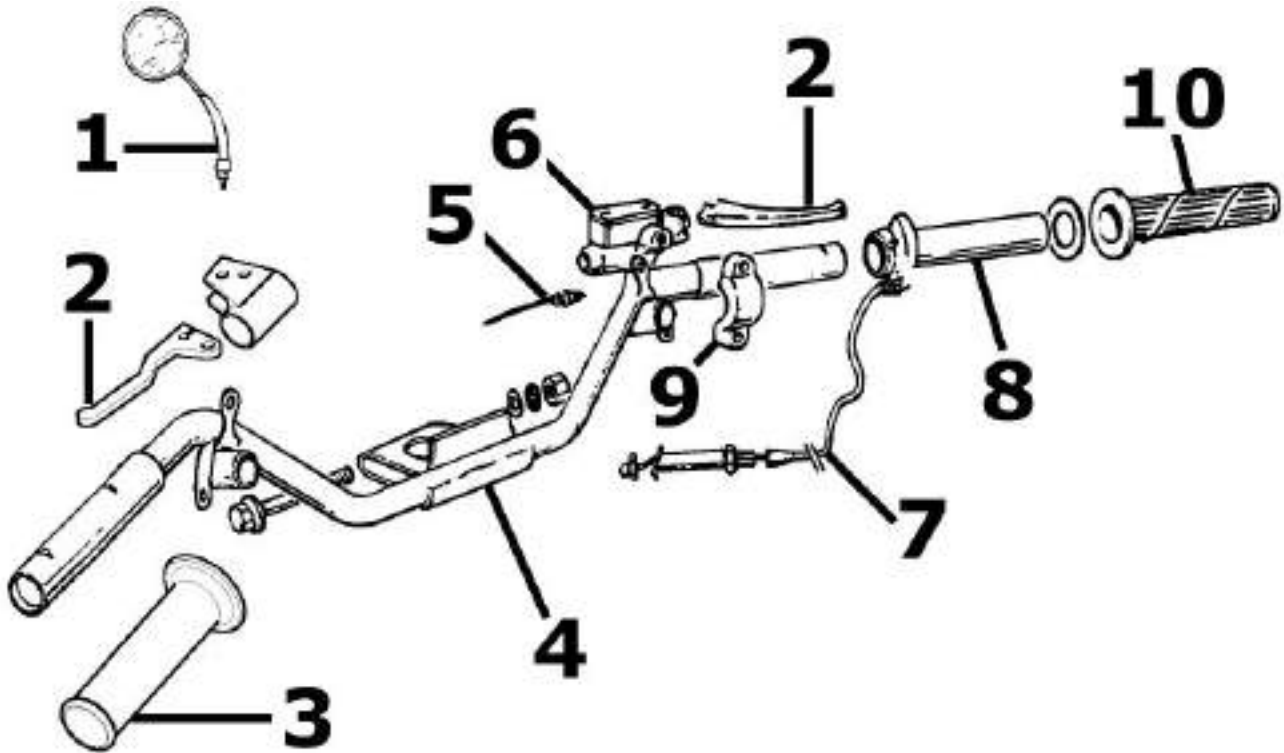

HANDLEBAR COMPONENTS

	Code	Action	Duration
1	004066	Driving mirror - Replacement	
2	002037	Brake or clutch lever - Replacement	
3	002071	Left hand grip - Replacement	
4	003001	Handlebar - Replacement	
5	005017	Stop switch - Replacement	
6	002024	Front brake pump - Removal and Re-fitting	
7	002063	Throttle control transmission - Replacement	
8	002060	Complete throttle control - Replacement	
9	004162	Mirror mounting and/or brake pump fitting U-bolt - Replacement	
10	002059	Right hand grip - Replacement	

Swing-arm

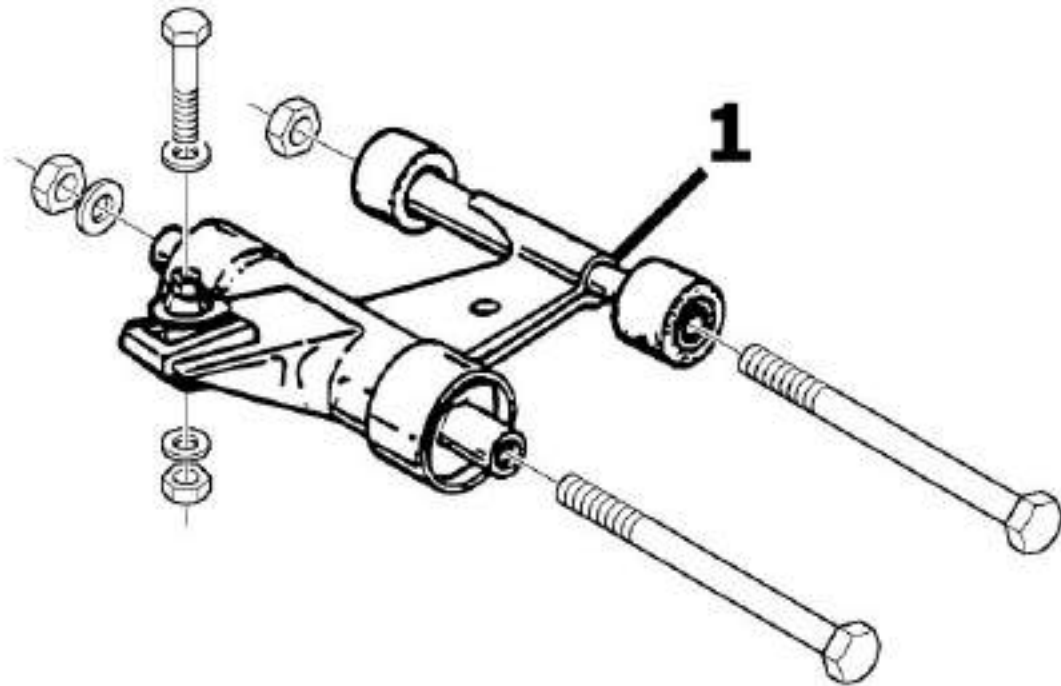

SWINGING ARM

	Code	Action	Duration
1	001072	Engine-chassis connection swinging arm - Replacement	

Seat

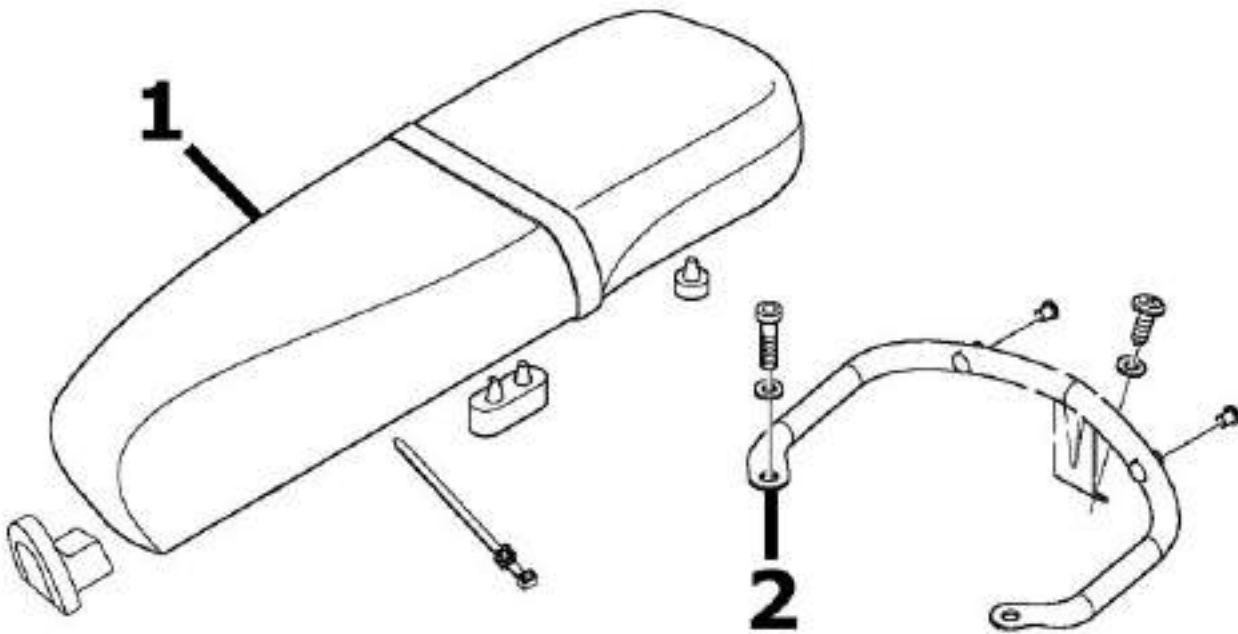
**SADDLE**

	Code	Action	Duration
1	004003	Saddle - Replacement	
2	004131	Luggage rack mounting - Replacement	

Turn signal lights

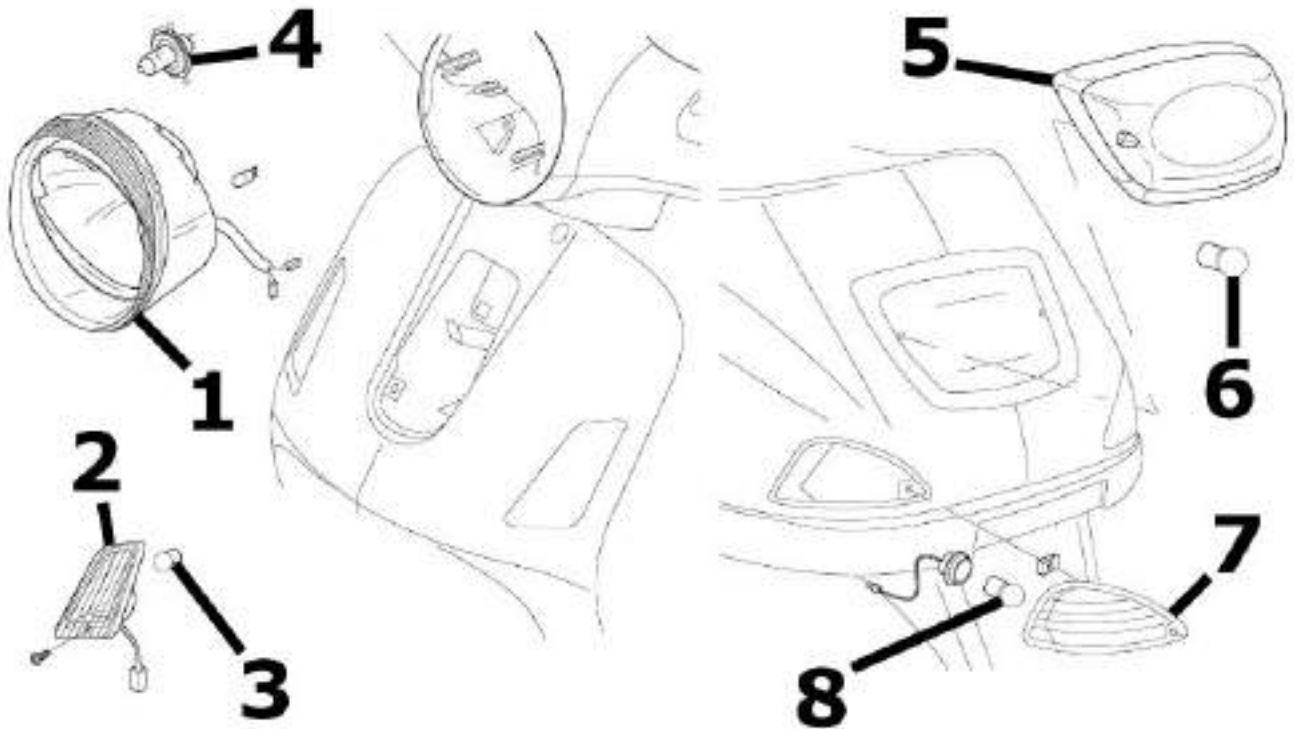

INDICATOR LIGHTS

	Code	Action	Duration
1	005002	Front headlamp - Replacement	
2	005012	Front turn indicator - Replacement	
3	005067	Front turn indicator bulb - Replacement	
4	005008	Headlight bulbs - Replacement	
5	005005	Taillight - change	
6	005066	Rear light bulbs - Replacement	
7	005022	Rear turning indicators - Replacement	
8	005068	Rear turning indicator bulb - Replacement	

Front wheel

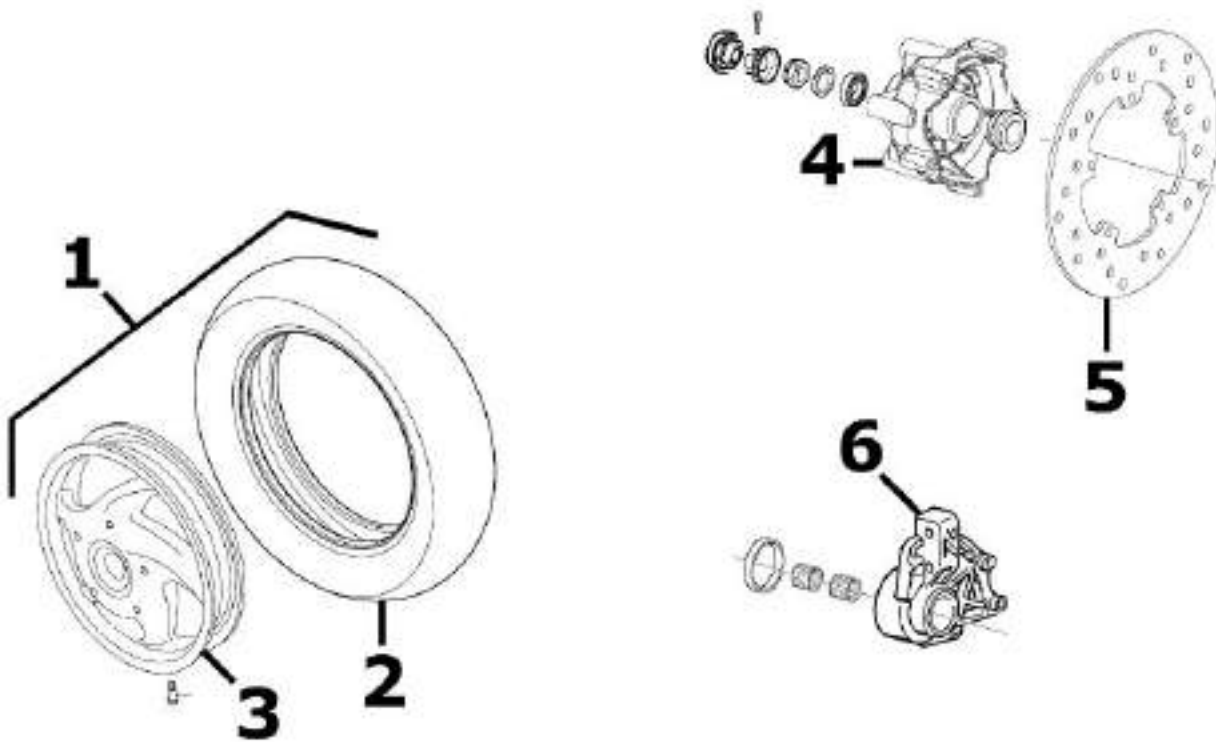

FRONT WHEEL

	Code	Action	Duration
1	004123	Front wheel - Replacement	
2	003047	Front tyre - Replacement	
3	003037	Front wheel rim - Replacement	
4	003033	Front wheel hub- Replacement	
5	002041	Front brake disc - Replacement	
6	003034	Front wheel hub bearing - Replacement	

Rear wheel

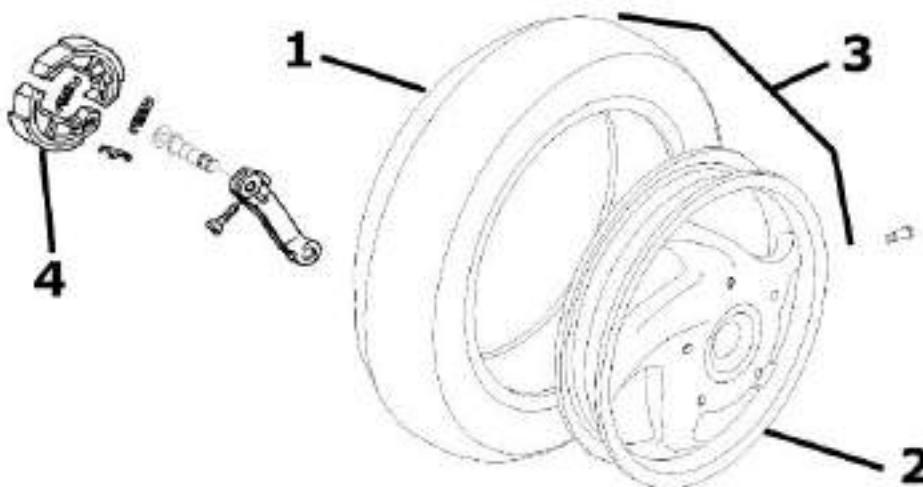

REAR WHEEL

	Code	Action	Duration
1	004126	Rear wheel tyre - Replacement	
2	001071	Rear wheel rim - Removal and Refitting	
3	001016	Rear wheel - Replacement	
4	002002	Rear brake pads/shoes - Repl.	

Electric devices

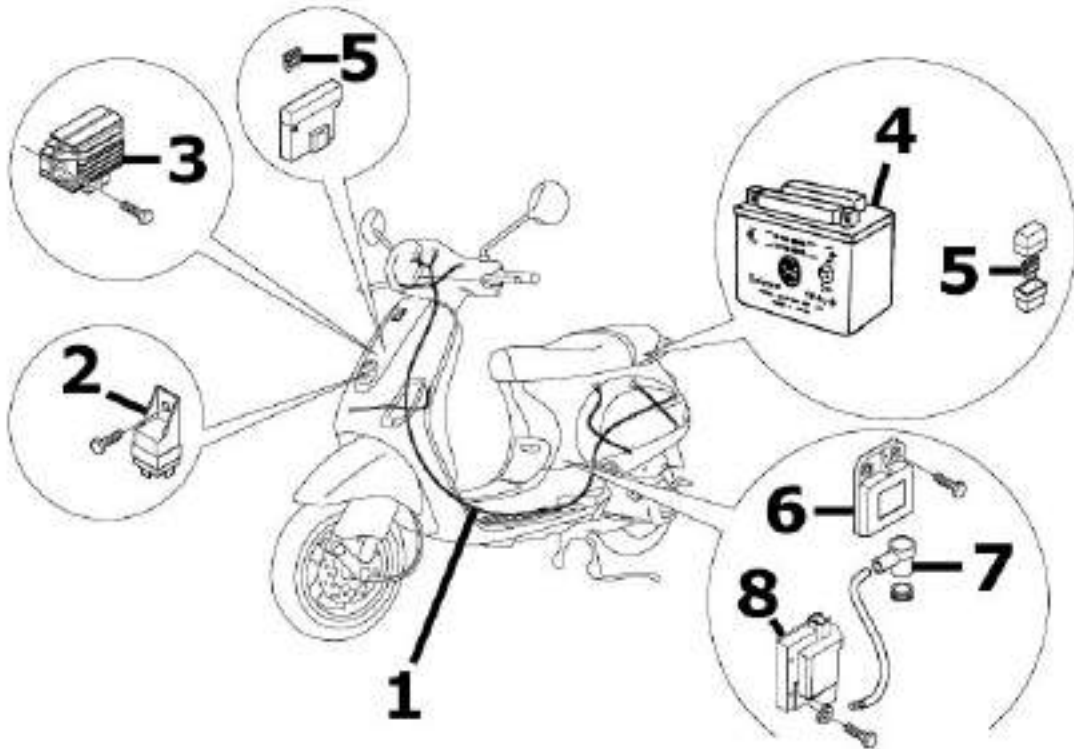

ELECTRICAL COMPONENTS

	Code	Action	Duration
1	005001	Electrical system - Replacement	
2	005011	Starter relay - Replacement	
3	005009	Voltage regulator - Replacement	
4	005007	Battery - change	
5	005052	Fuse (1) - Replacement	
6	001023	Control unit - Replacement	
7	001094	Spark plug cap - Replacement	
8	001069	HV coil - Replacement	

Electronic controls

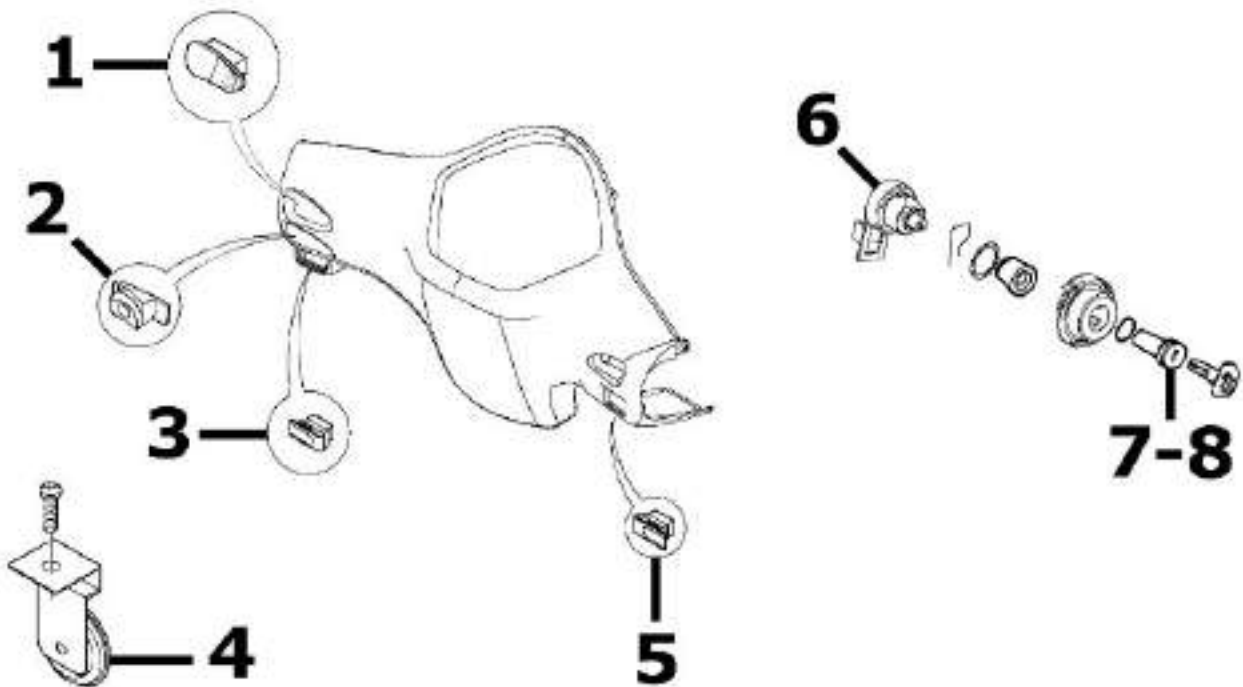

ELECTRIC CONTROLS

	Code	Action	Duration
1	005039	Lights switch - Replacement	
2	005006	Light or turning indicator switch - Replacement	
3	005040	Horn button - Replacement	
4	005003	Horn - Replacement	
5	005041	Starter button - Replacement	
6	005016	Key switch - Replacement	
7	004096	Lock series - Replacement	
8	004010	Anti-theft lock - Replacement	

Transmissions

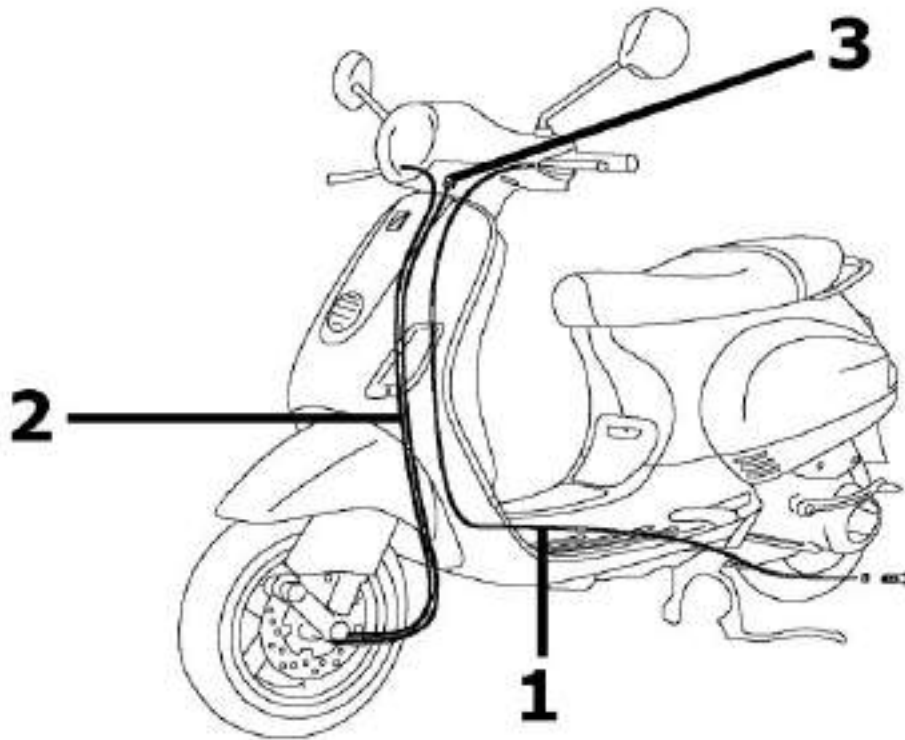

TRANSMISSION

	Code	Action	Duration
1	002053	Rear brake transmission complete - Replacement	
2	002051	Odometer transmission assembly - Replacement	
3	002049	Odometer cable - Replacement	

Front suspension

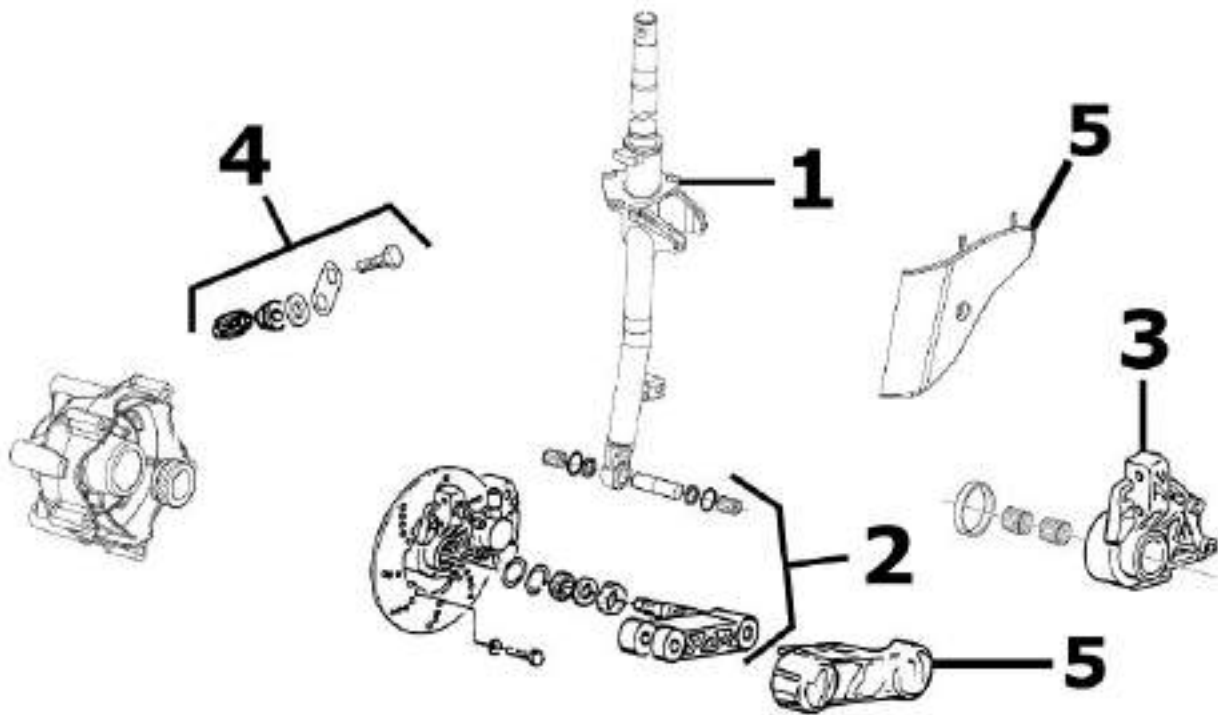

FRONT SUSPENSION

	Code	Action	Duration
1	003045	Steering tube/Fork tube - Replacement	
2	003010	Front suspension - Service	
3	003035	Shock absorber mounting and brake calliper - Replacement	
4	001064	Odometer sprocket - Replacement	
5	003044	Shock absorber cover - Replacement	

Braking system

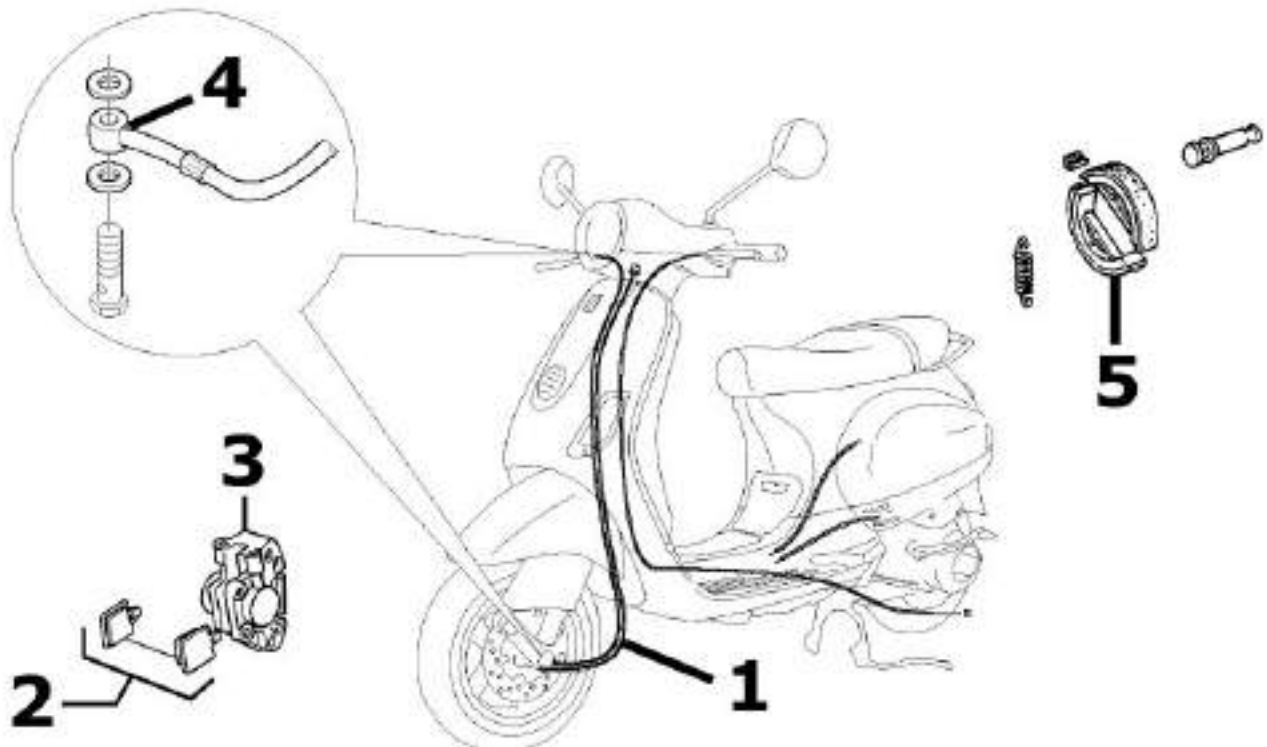

BRAKING SYSTEM

	Code	Action	Duration
1	002021	Front brake hose - Remov. and Refitt.	
2	002007	Front brake shoes/pads - Remov. and Refitt	
3	002039	Front brake calliper - Removal and Refitting	
4	002047	Front brake fluid and air bleed system - Replacement	
5	002002	Shoes - Rear brake pads - Replacement	

Secondary air box

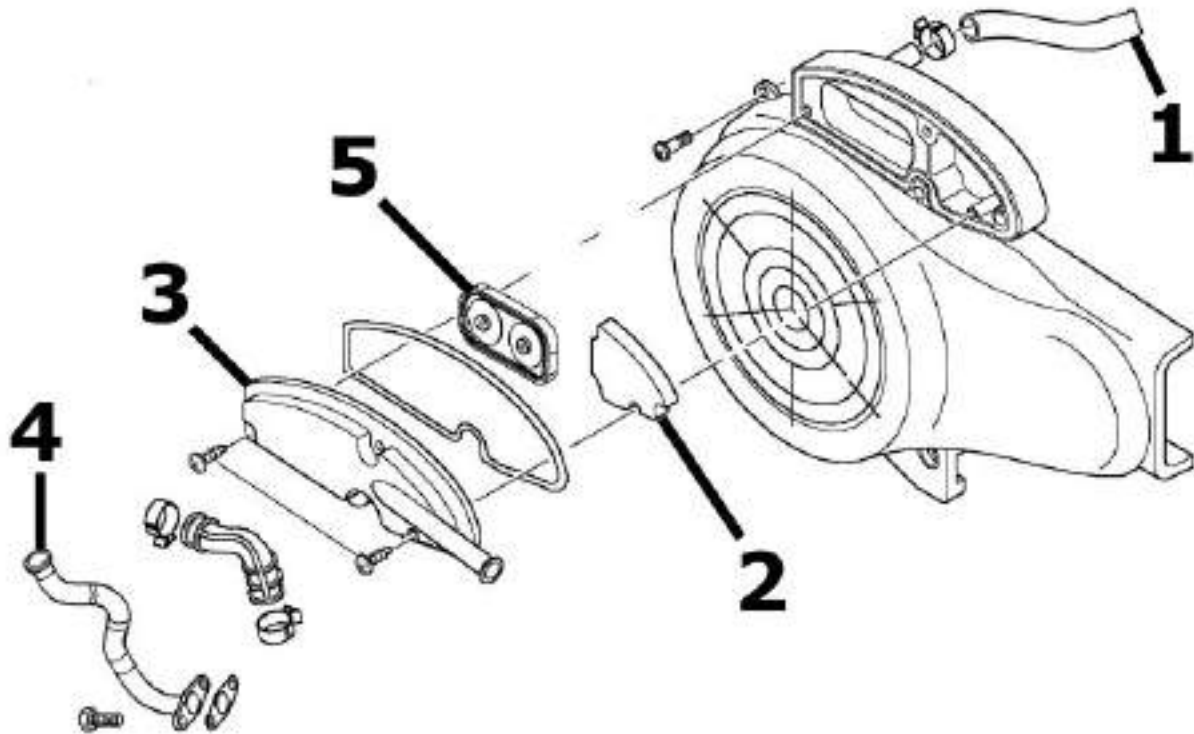

SECONDARY AIR HOUSING

	Code	Action	Duration
1	001164	Crankcase secondary air connection - Replacement	
2	001161	Secondary air filter - Replacement / Cleaning	
3	001162	Secondary air housing - Replacement	
4	001163	Silencer secondary air connection - Replacement	
5	001165	Secondary air reed - Replacement	

A

Air filter: 40, 159

B

Battery: 49, 54, 62, 64

Brake: 147–150, 152

C

Carburettor: 36, 120, 123, 182

Checks: 55

E

Electric: 201

Engine oil: 40

Engine stop:

F

Fuel: 48, 119, 160, 192

H

Headlight: 43, 156

Hub oil: 39

I

Identification: 8

Instrument panel: 155

M

Maintenance: 7, 36

O

Odometer:

Oil filter: 41

R

Recommended products:

S

Saddle:

Shock absorbers: 144

Spark plug: 38, 57

Stand:

Start-up:

Suspension: 49, 50, 204

T

Tank: 160, 192

Transmission: 9, 48, 72, 82, 179

Tyres: 13

V

Vehicle: 8, 70