

TABLE OF CONTENTS

SPECIFICATIONS.....	1
GENERAL INFORMATION.....	2
INSPECTION/ADJUSTMENT.....	3
LUBRICATION SYSTEM.....	4
ENGINE REMOVAL/INSTALLATION.....	5
CYLINDER HEAD.....	6
CYLINDER/PISTON.....	7
A.C. GENERATOR.....	8
DRIVE PULLEY.....	9
FINAL REDUCTION.....	10
CRANKCASE/CRANKSHAFT.....	11
FUEL SYSTEM.....	12
FRAME COVERS.....	13
STEERING HANDLEBAR/FRONT WHEEL/FRONT BRAKE/ FRONT SHOCK ABSORBER/FRONT FORK.....	14
REAR WHEEL/REAR BRAKE/REAR SHOCK ABSORBER.....	15
ELECTRICAL EQUIPMENT.....	16
INSTRUMENT/SWITCHES/LIGHTS.....	17

SPECIFICATIONS

Name & Model		LIKE 200i
Overall length (mm)		1923
Overall width (mm)		685
Overall height (mm)		1110
Wheel base (mm)		1315
Engine type		Air cooled 4-stroke
Fuel Used		95# nonleaded gasoline
Displacement (cc)		163 cc
Net weight (kg)		120
Tires	Front wheel	120/70-12
	Rear wheel	130/70-12
Ground clearance (mm)		120
Braking distance (m) (Initial speed Km/h)		4.4m (30km/h)
Min. turning radius (mm)		1900
Starting system		Starting motor
Fuel		Gasoline
Cylinder arrangement		Single cylinder, flat
Combustion chamber type		Semi-sphere
Bore x stroke (mm)		60x57.8
Compression ratio		9.5
Compression pressure (kg/cm ² rpm)		15kg/cm ² ±2
Max. output		11.5/7500 ps/rpm
Idle (rpm)		1800±100
Engine oil capacity (liter)		0.9
Fuel capacity (liter)		6

Air cleaner type & No.		Paper element,Wet
Ignition system		ECU
Ignition timing		3°~17° BTDC
Spark Plug		NGK- CR7HSA
Spark plug gap (mm)		0.6~0.7
Battery capacity		12V-9AH
Power to transmission gear		Power-transmission gear-clutch
Clutch type		Dry multi-disc clutch
Transmission gear operation type		Automatic centrifugal type
Reduction gear	Type	Two-stage reduction
	1st reduction ratio	3.1~0.9
	2nd reduction ratio	12.69
Transmission gear type		Non-stage
Tire pressure (kg/cm ²)	Front wheel	1.75 kg/cm ²
	Rear wheel	2.25 kg/cm ²
Turning angle		Right & left 45°
Brake system type	Front wheel	Disk
	Rear wheel	Disk
Suspension type	Front wheel	Telescope
	Rear wheel	Unit swing
Frame type		Pipe under bone

GENERAL INFORMATION

ENGINE SERIAL NUMBER/IDENTIFICATION 2- 1

SERVICE PRECAUTIONS 2- 2

TORQUE VALUES 2- 10

SPECIAL TOOLS 2- 12

LUBRICATION POINTS 2- 12

WIRING DIAGRAM..... 2- 14

CABLE & HARNESS ROUTING..... 2- 15

TROUBLESHOOTING..... 2-19

ENGINE SERIAL NUMBER/IDENTIFICATION



Location of Engine Serial Number

SERVICE PRECAUTIONS

- Make sure to install new gaskets, O-rings, circlips, cotter pins, etc. when reassembling.

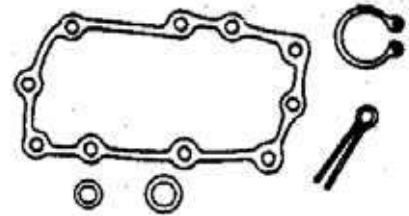

- When tightening bolts or nuts, begin with larger-diameter to smaller ones at several times, and tighten to the specified torque diagonally.

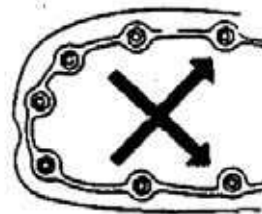

- Use genuine parts and lubricants.

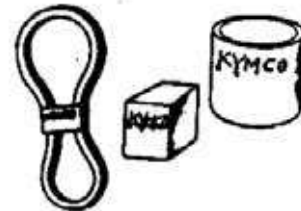

- When servicing the motorcycle, be sure to use special tools for removal and installation.



- After disassembly, clean removed parts. Lubricate sliding surfaces with engine oil before reassembly.



- Apply or add designated greases and lubricants to the specified lubrication points.

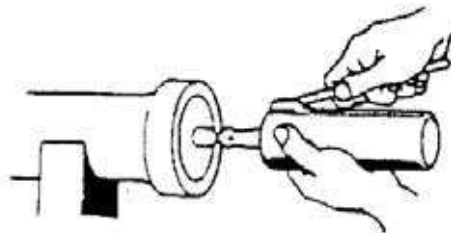

- After reassembly, check all parts for proper tightening and operation.

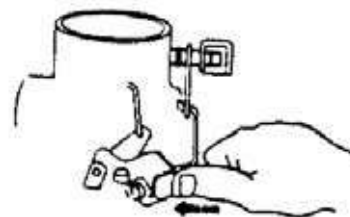

- When two persons work together, pay attention to the mutual working safety.

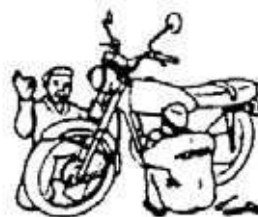

- Disconnect the battery negative (-) terminal before operation.
- When using a spanner or other tools, make sure not to damage the motorcycle surface.

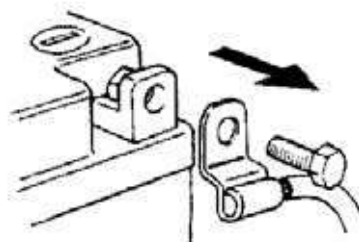

- After operation, check all connecting points, fasteners, and lines for proper connection and installation.
- When connecting the battery, the positive (+) terminal must be connected first.
- After connection, apply grease to the battery terminals.
- Terminal caps shall be installed securely.

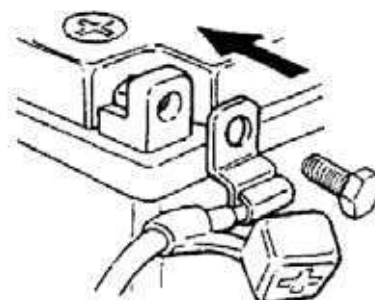

2. GENERAL INFORMATION

LIKE 200i

- If the fuse is burned out, find the cause and repair it. Replace it with a new one according to the specified capacity.

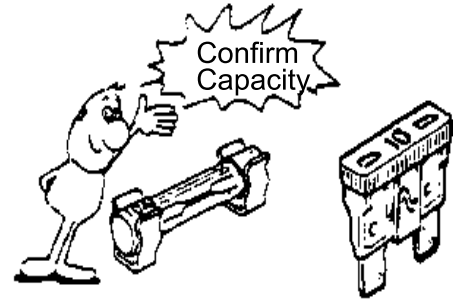

- After operation, terminal caps shall be installed securely.



- When taking out the connector, the lock on the connector shall be released before operation.

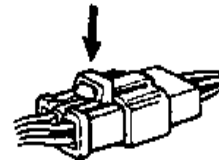

- Hold the connector body when connecting or disconnecting it.
- Do not pull the connector wire.

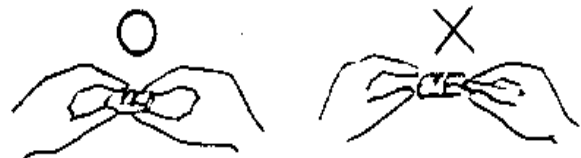

- Check if any connector terminal is bending, protruding or loose.

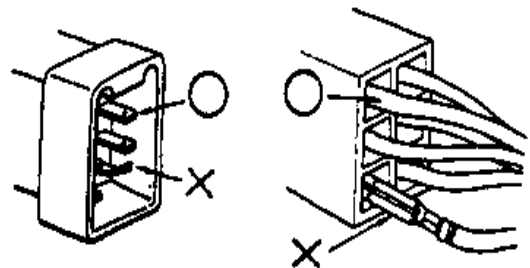

2. GENERAL INFORMATION

LIKE 200i

- The connector shall be inserted completely.
- If the double connector has a lock, lock it at the correct position.
- Check if there is any loose wire.

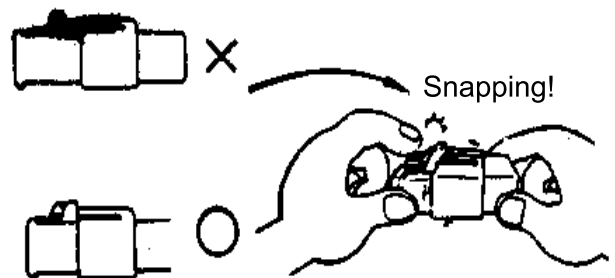

- Before connecting a terminal, check for damaged terminal cover or loose negative terminal.

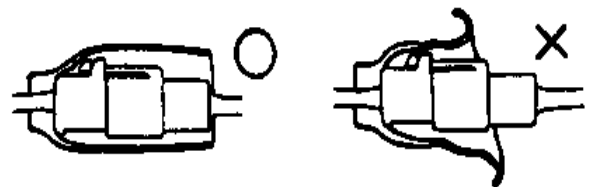

- Check the double connector cover for proper coverage and installation.

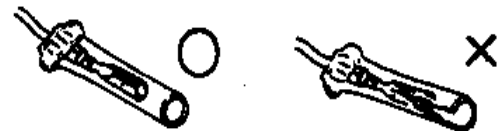

- Insert the terminal completely.
- Check the terminal cover for proper coverage.
- Do not make the terminal cover opening face up.



- Secure wire harnesses to the frame with their respective wire bands at the designated locations. Tighten the bands so that only the insulated surfaces contact the wire harnesses.

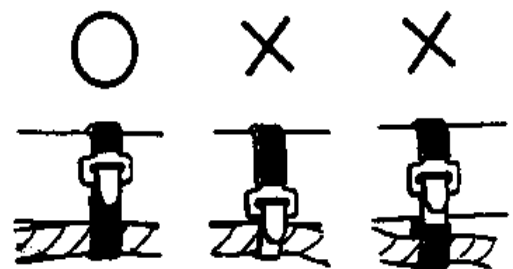

- After clamping, check each wire to make sure it is secure.

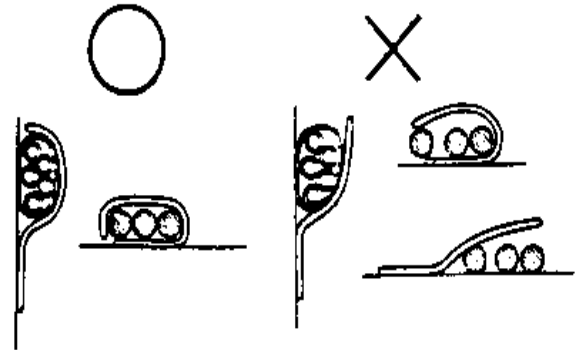

- Do not squeeze wires against the weld or its clamp.

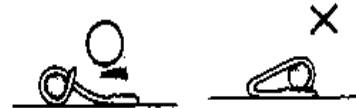

- After clamping, check each harness to make sure that it is not interfering with any moving or sliding parts.

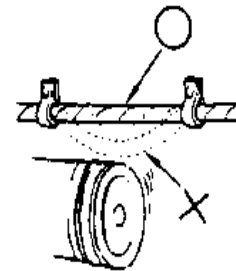

- When fixing the wire harnesses, do not make it contact the parts which will generate high heat.

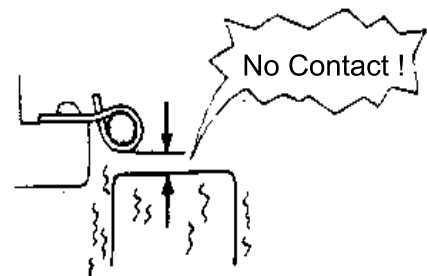

- Route wire harnesses to avoid sharp edges or corners. Avoid the projected ends of bolts and screws.
- Route wire harnesses passing through the side of bolts and screws. Avoid the projected ends of bolts and screws.



- Route harnesses so they are neither pulled tight nor have excessive slack.

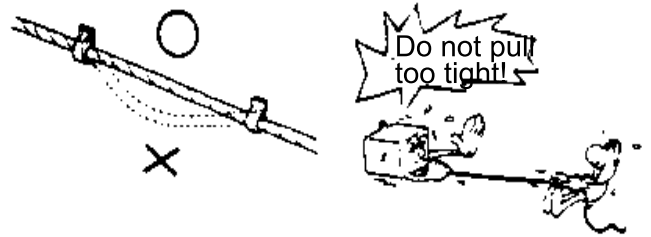

- Protect wires and harnesses with electrical tape or tube if they contact a sharp edge or corner.

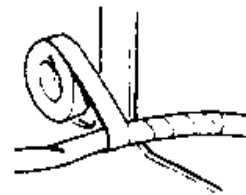

- When rubber protecting cover is used to protect the wire harnesses, it shall be installed securely.

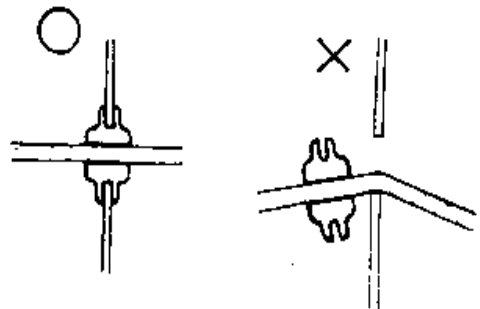

- Do not break the sheath of wire.
- If a wire or harness is with a broken sheath, repair by wrapping it with protective tape or replace it.

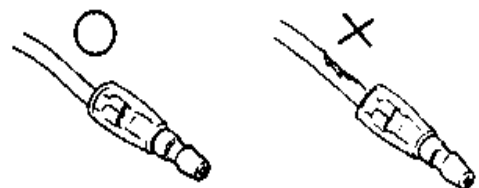

- When installing other parts, do not press or squeeze the wires.

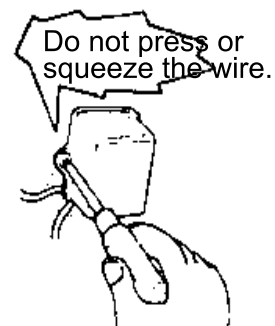

- After routing, check that the wire harnesses are not twisted or kinked.

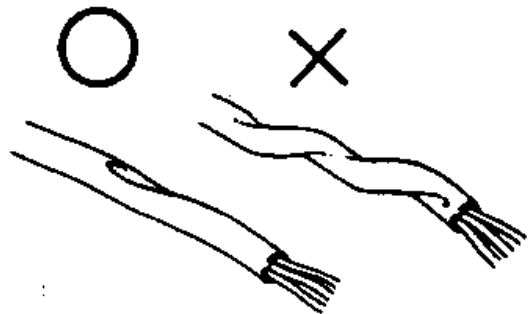

- Wire harnesses routed along with handlebar should not be pulled tight, have excessive slack or interfere with adjacent or surrounding parts in all steering positions.



- When a testing device is used, make sure to understand the operating methods thoroughly and operate according to the operating instructions.

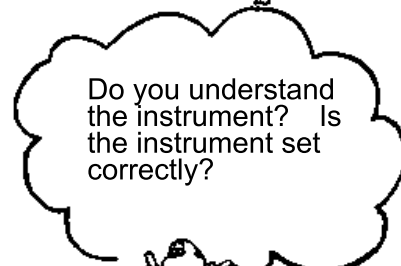

- Be careful not to drop any parts.



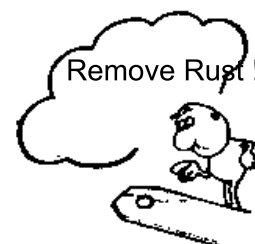

- When rust is found on a terminal, remove the rust with sand paper or equivalent before connecting.





■ Symbols:

The following symbols represent the servicing methods and cautions included in this service manual.

 : Apply engine oil to the specified points. (Use designated engine oil for lubrication.)
Engine Oil

 : Apply grease for lubrication.
Grease

 : Use special tool.
Special

 : Caution

 : Warning

2. GENERAL INFORMATION

LIKE 200i

TORQUE VALUES ENGINE

Item	Thread dia. (mm)	Torque (N-m)	Remark	Drawing No.
Bolt A STUD 8*218	M8 * 1.25	8.9	Stud Side	90031-KBE-9000
Bolt B STUD 8*210	M8 * 1.25	8.9	Stud Side	90032-KBE-9000
Tappet Adjust Hole Cap	M30 *1.5	14.7		12361-GY6-9010
L Cover	M6 * 1.0	11.8		96001-06032-08
Cover, L cover	M6 * 1.0	11.8		95701-06016-02
Cylinder Head	STUD M6 * 1.0	8.9	Inlet Pipe Area	92900-06050-0B
Cylinder Head	STUD M8 * 1.25	8.9	Ex Pipe Area	90033-GY6-9000
Cylinder Head	STUD M6 * 1.0	8.9	A/I Pipe Area	90033-GY6-9410
Cam Shaft Holder	N.F. M8 * 1.25	24.5	Apply Oil	94050-08000
Breather Separator Plate	Tapping Screw 4mm	3.2		93903-34120
Tappet Adjust Nut	M5 * 0.5	8.9	Apply Oil	90206-001-0010
Cam Chain Tensioner Pivot	Special Bolt M8 * 1.25	9.8		14531-KHE7-9000
Tensioner Lifter	SHF M6 * 1.0	11.8		90001-GH8-6610
Tensioner Lifter	M6 * 1.0	4.2		90005-KEC8-9000
Oil Pump	Screw Pan M3 * 0.5	2.0		93500-03010-1A
A/I Pipe	CAP Nut M6 * 1.0	11.8		90304-438-0010
Mission Case	M8 * 1.25	19.7		95701-08030-08
L Case Check/Drain Bolt	M8 * 1.25	9.8		95701-08012-08
L Case Drain Bolt	M12 * 1.5	24.5		9052A-GY6-9500
Drive Face	M14 * 1.25	93.1	Apply Oil	90201-KR8-7520-M1
Clutch Outer	N.F. M12 * 1.25	54		90201-KHE7-9000
Drive Plate Comp	M28 * 1.0	54		90202-187-0010
Oneway Clutch	Bolt Socket M8 * 1.25	19.7	Apply Thread Lock	96600-08015-10
ACG Flywheel	N.F. M14 * 1.25	58.8		90201-KR8-7520-M1
Spark plug	M12 * 1.25	17.2		98069-57911-01
Water Pump Impeller	M7 * 1.0	11.8	LH Screw	19215-KHE7-9000
ACG Stator	M5 * 0.8	8.8		92101-05032-OH
Other	SH Bolt	9.8		

2. GENERAL INFORMATION

LIKE 200i

TORQUE VALUES FRAME

Item	Thread dia. (mm)	Torque (N-m)	Remark	Drawing No.
STEERING				
- Handle Post	M10 * 1.25	45	U Nut	90106-GEN5-9000
- Bridge Bolt	M8 * 1.25	27		95801-08040-08
- Stem Lock	BCI	70		50306-1F96-0010
- Race Nut (Head)	BCI	20		53220-LBA2-E000
WHEEL				
- FR Axle Nut	M14 * 1.5	65	U Nut	90305-GHE8-0040
- RR Axle Nut	M16 * 1.5	120	U Nut	90305-KFW6-9120-M1
SUSPENSION				
- RR Cushion Up	M10 * 1.25	40		95801-10035-00
- RR Cushion Lower	M10 * 1.25	40		95801-10035-00
BRAKE				
- FR Caliper	M8 * 1.25	27		90131-GLW0-9110
- Brake Fluid Bolt	M10 * 1.25	35		90145-MS9-6120-M1
- M/C Holder	M6 * 1.0	12		96001-06022-06
- M/C Cap Screw	M4 * 0.7	1.16		96001-04012-1A
- Caliper Bleeder	M8 * 1.25	5.5		43352-5H68-0040
- Disk Bolt	M8 * 1.25	35		90105-KCR3-0010
ENG Hanger				
- Frame Side	M12 * 1.25	50	Flange Bolt	90106-KHE7-E000
- ENG Side	M10 * 1.25	50	U Nut	90304-GHE8-0040
MUFFLER				
- EXH. Pipe	M8 * 1.25	20		90033-GFY6-9000
- Muffler Bracket / RR Fork	M10 * 1.25	35	Flange Bolt	95801-10050-00
RR Fork / ENG Case	M8 * 1.25	32		95801-08055-00
OTHER				
- Ignition Coil	M6 * 1.0	3		94050-06080
- O2 Sensor	M12 * 1.25	25		
- RR Carrier	M8 * 1.25	12		90106-KKC4-9000

2. GENERAL INFORMATION

LIKE 200i

SPECIAL TOOLS

Tool Name	Tool No.	Remarks	Ref. Page
Clutch spring compressor	E034	Clutch disassembly	
Bearing puller 10,12,15,18mm	E037	Bearing removal	
Valve spring compressor	E040	Valve removal	
Oil seal & bearing installer	E014	Oil seal & bearing install	
Tappet adjuster	E036	Tappet adjustment	
Flywheel puller	E003	A.C. generator flywheel removal	
Universal holder	E017	Holding clutch for removal	
Flywheel holder	E021	A.C. generator flywheel holding	
Lock nut socket wrench	F002	Steering stem removal or install	

LUBRICATION POINTS ENGINE

Lubrication Points	Lubricant
Valve stem	<ul style="list-style-type: none"> • Engine Oil (SAE15W-40) • API: SE, SF or SG
Camshaft	
Valve rocker arm	
Camshaft drive chain	
Cylinder lock bolt / nut	
Piston / Piston Ring	
Piston Pin	
Cylinder inside	
Connecting Rod / Piston Pin Hole	
Connecting Rod big end	
Crankshaft	
One-way clutch	
Oil pump drive chain	
Starter Reduction Gear	
Countershaft Gear	
Final Gear	
Starter Idle Gear	
Starter Spindle	
A.C. Generator Connector	Adhesive
Transmission Case Breather Tube	

FRAME

Apply clean engine oil or grease to cables and movable parts not specified. This will avoid abnormal noise and rise the durability of the motorcycle.

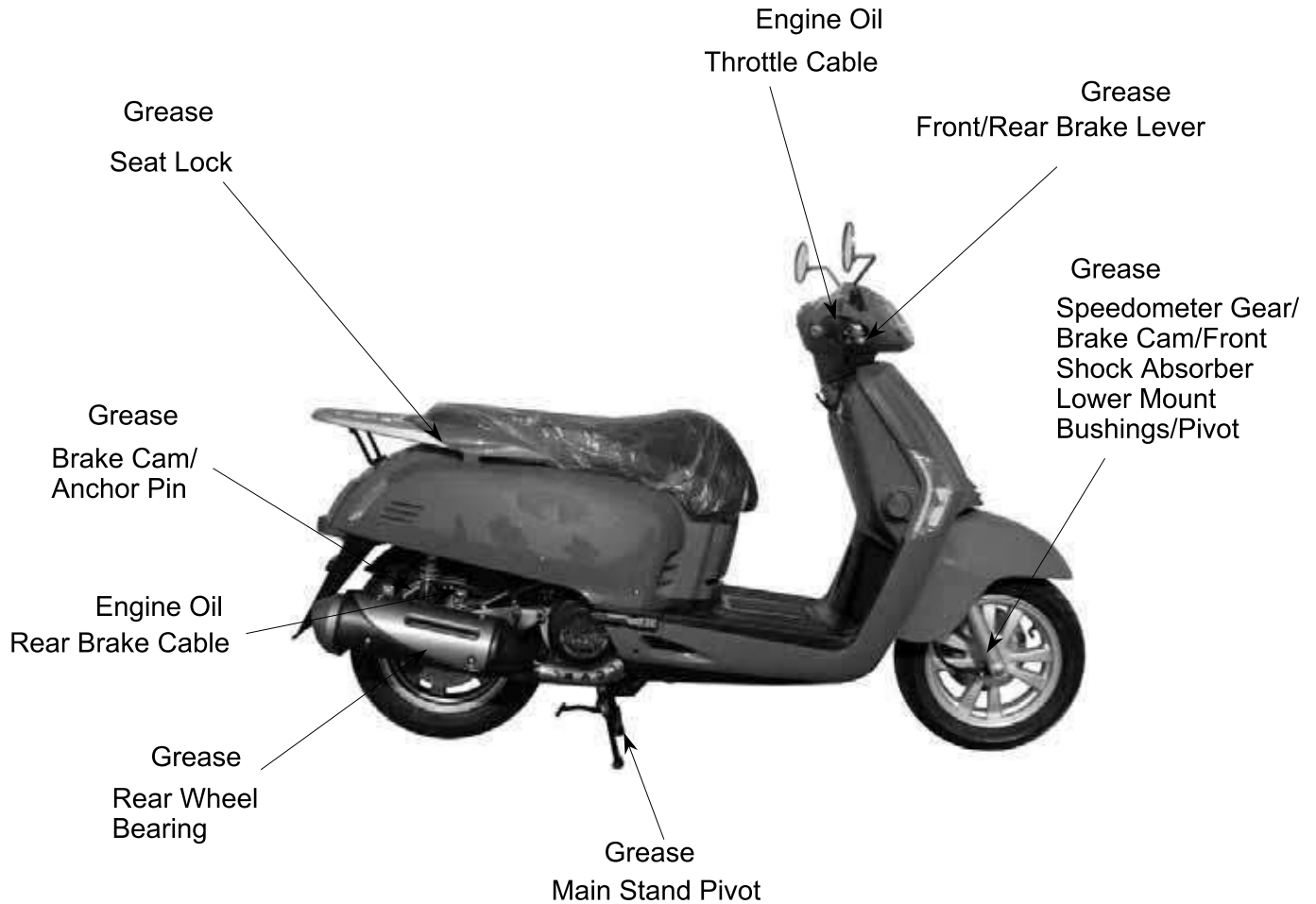

CABLE & HARNESS ROUTING

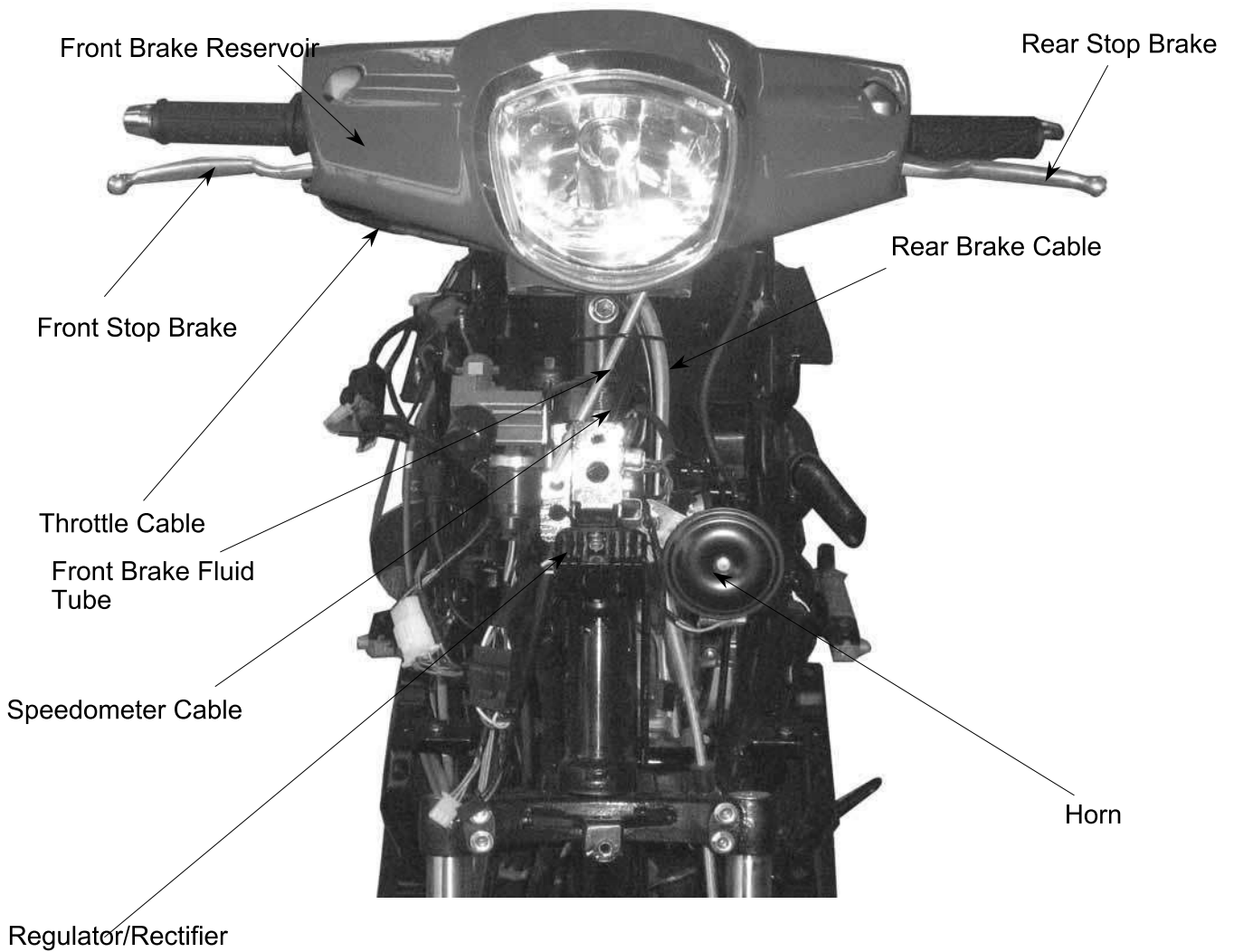

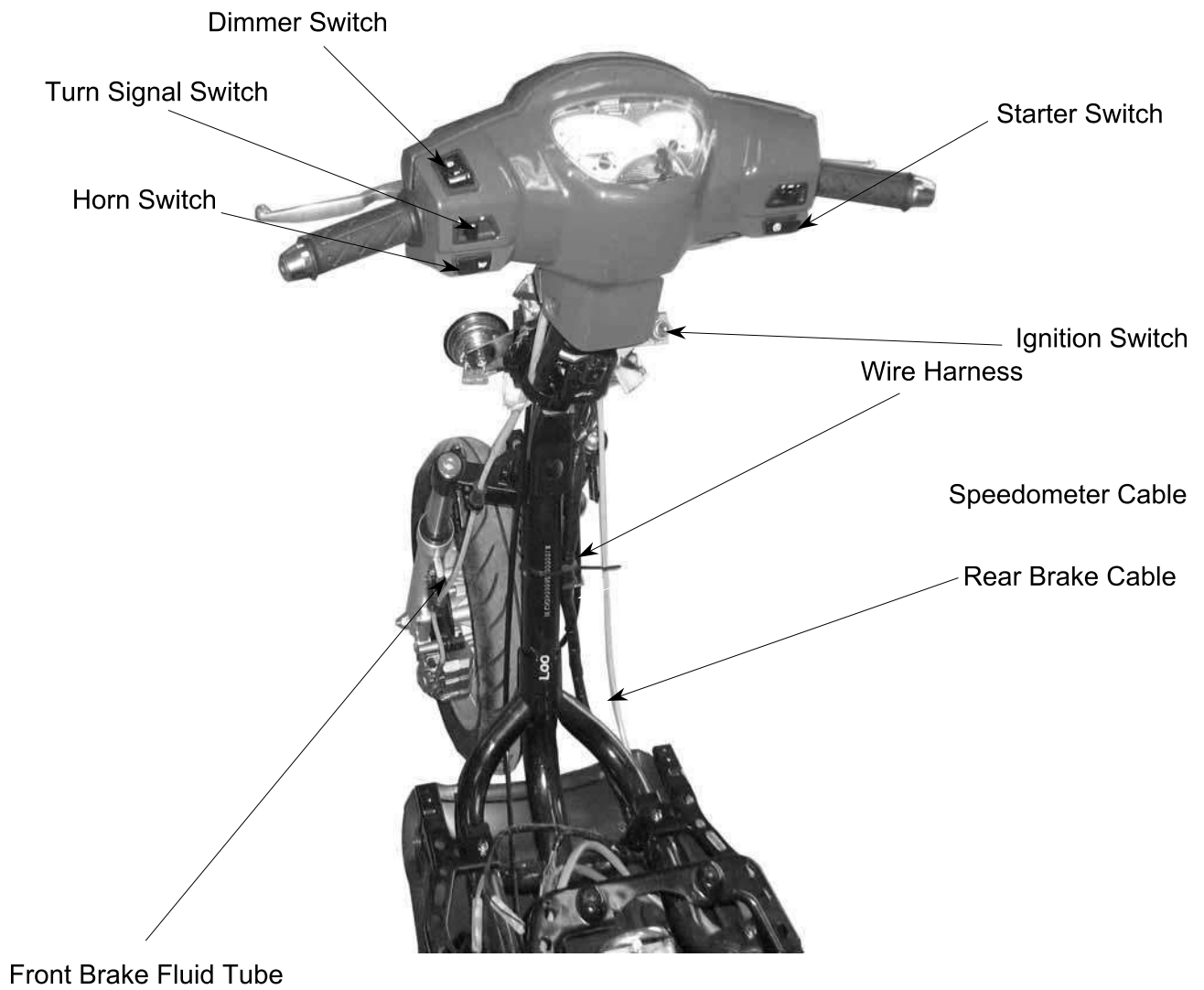

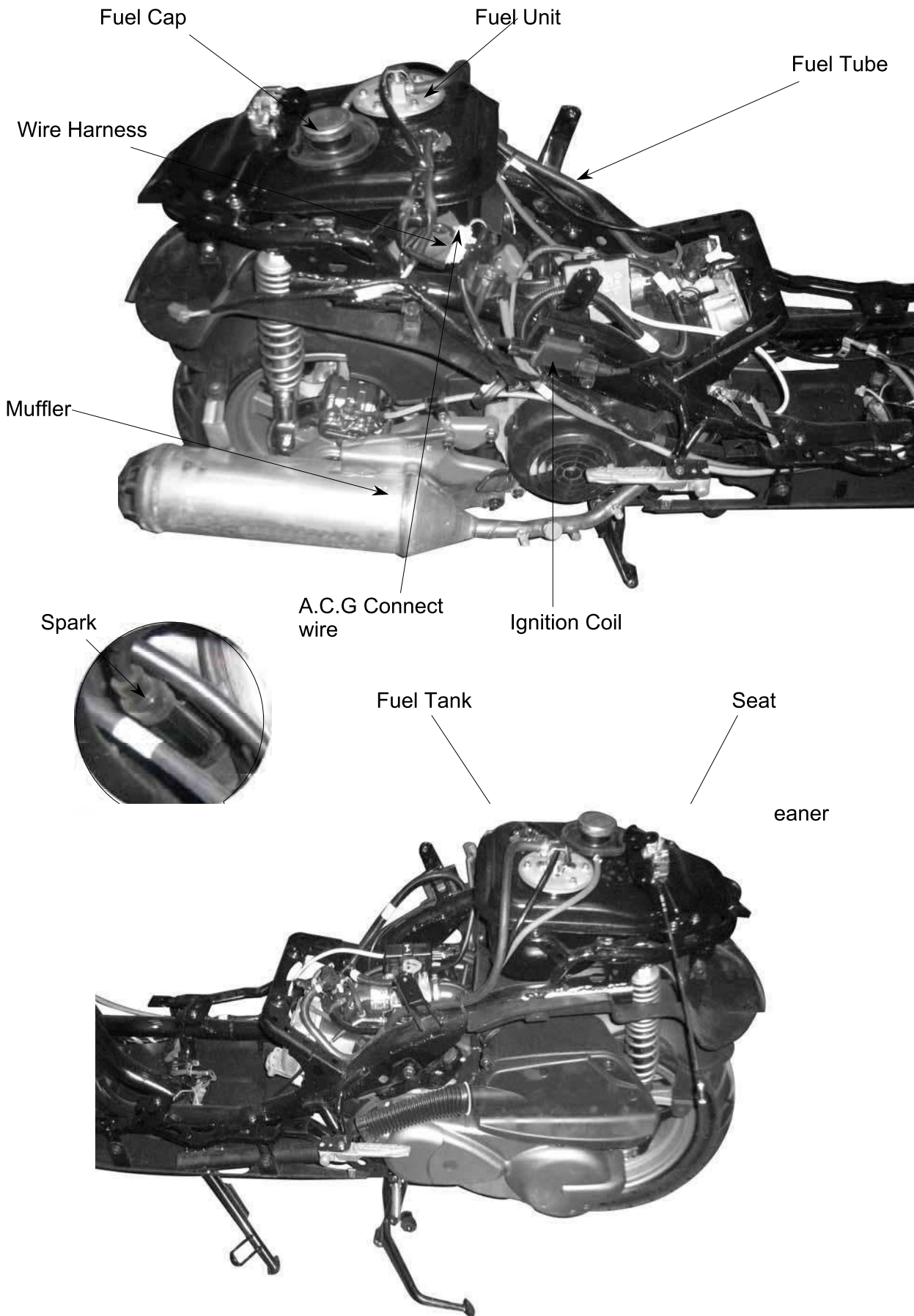

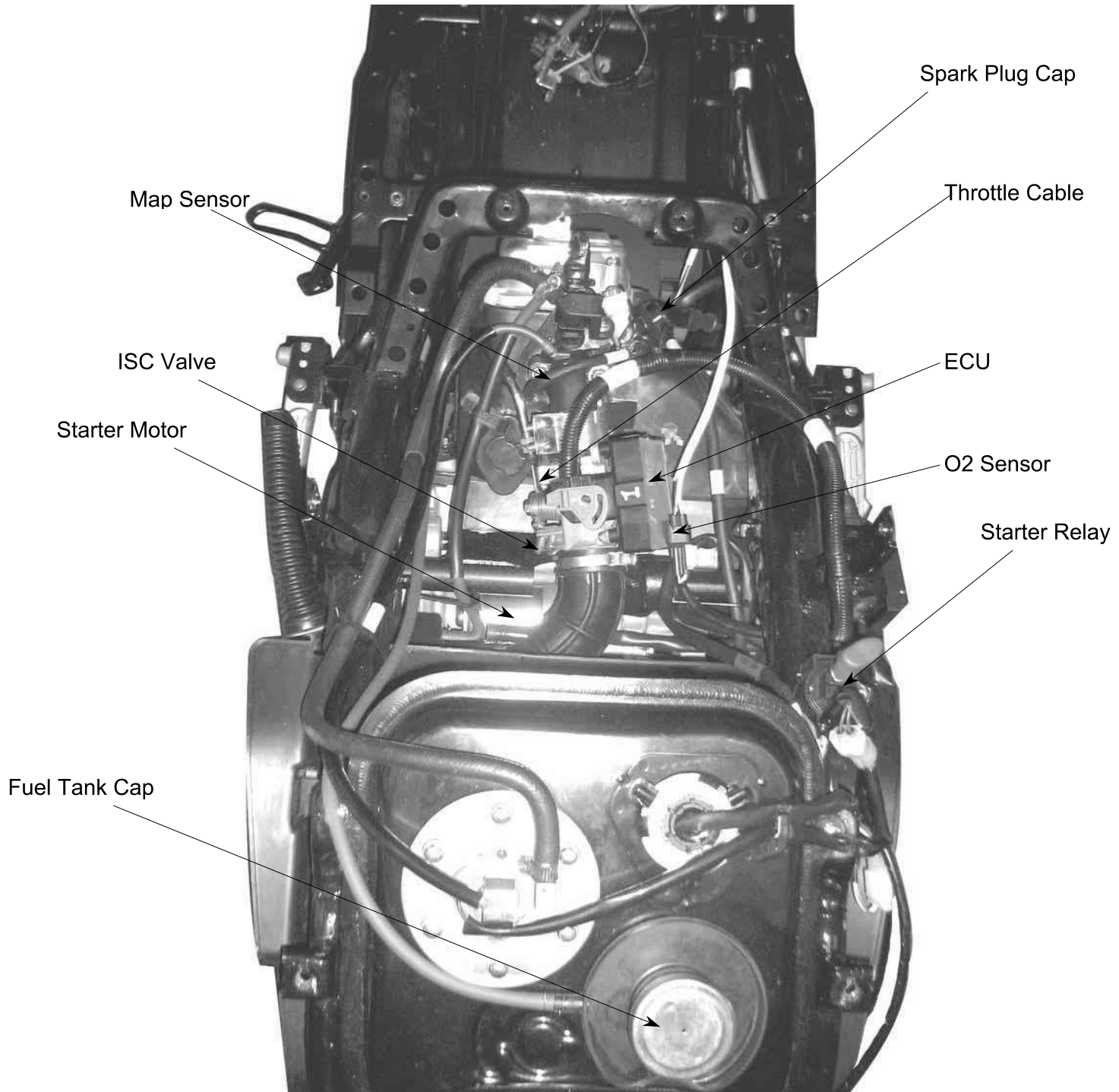

TROUBLESHOOTING

ENGINE WILL NOT START OR IS HARD TO START

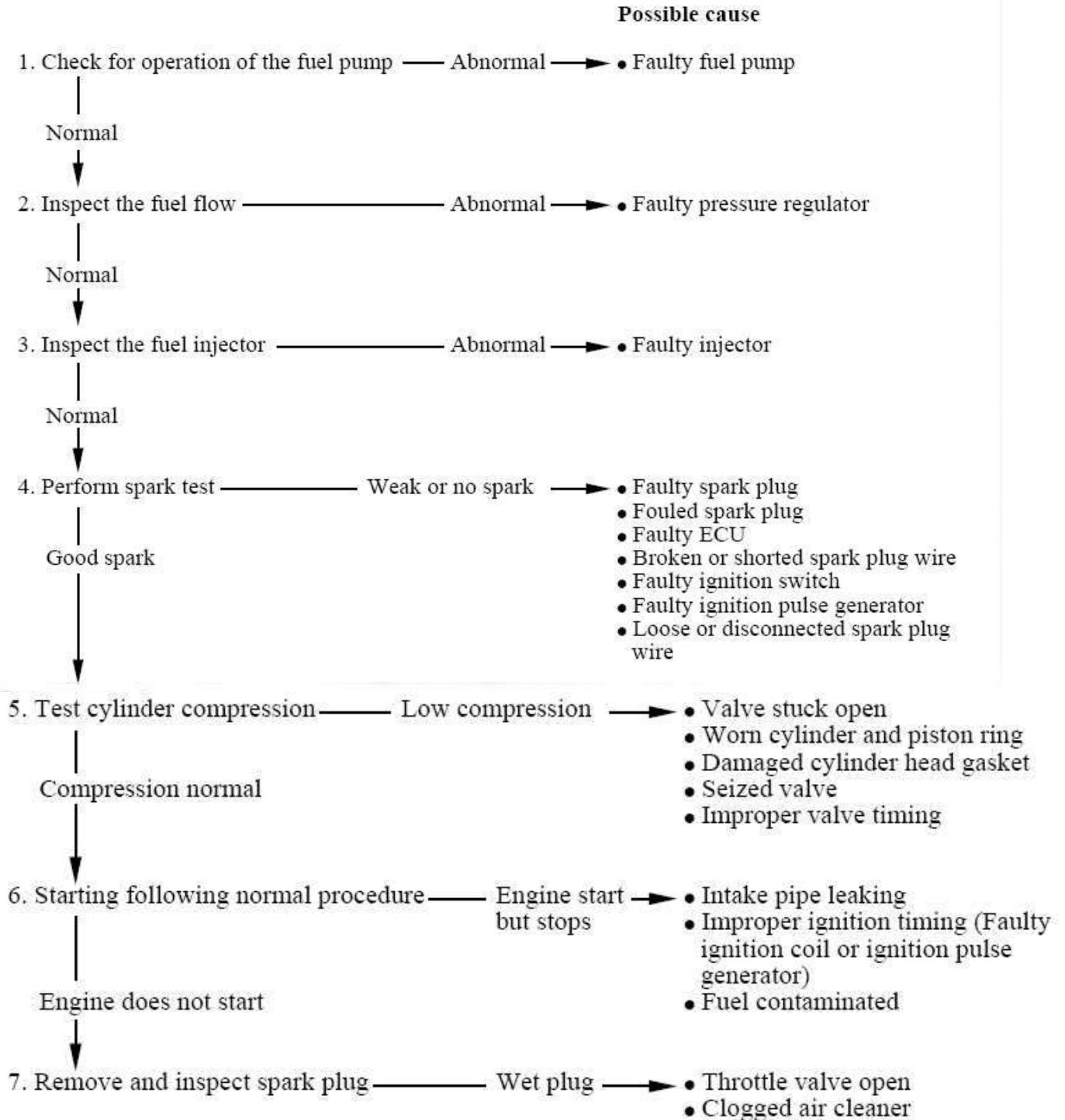

ENGINE LACKS POWER

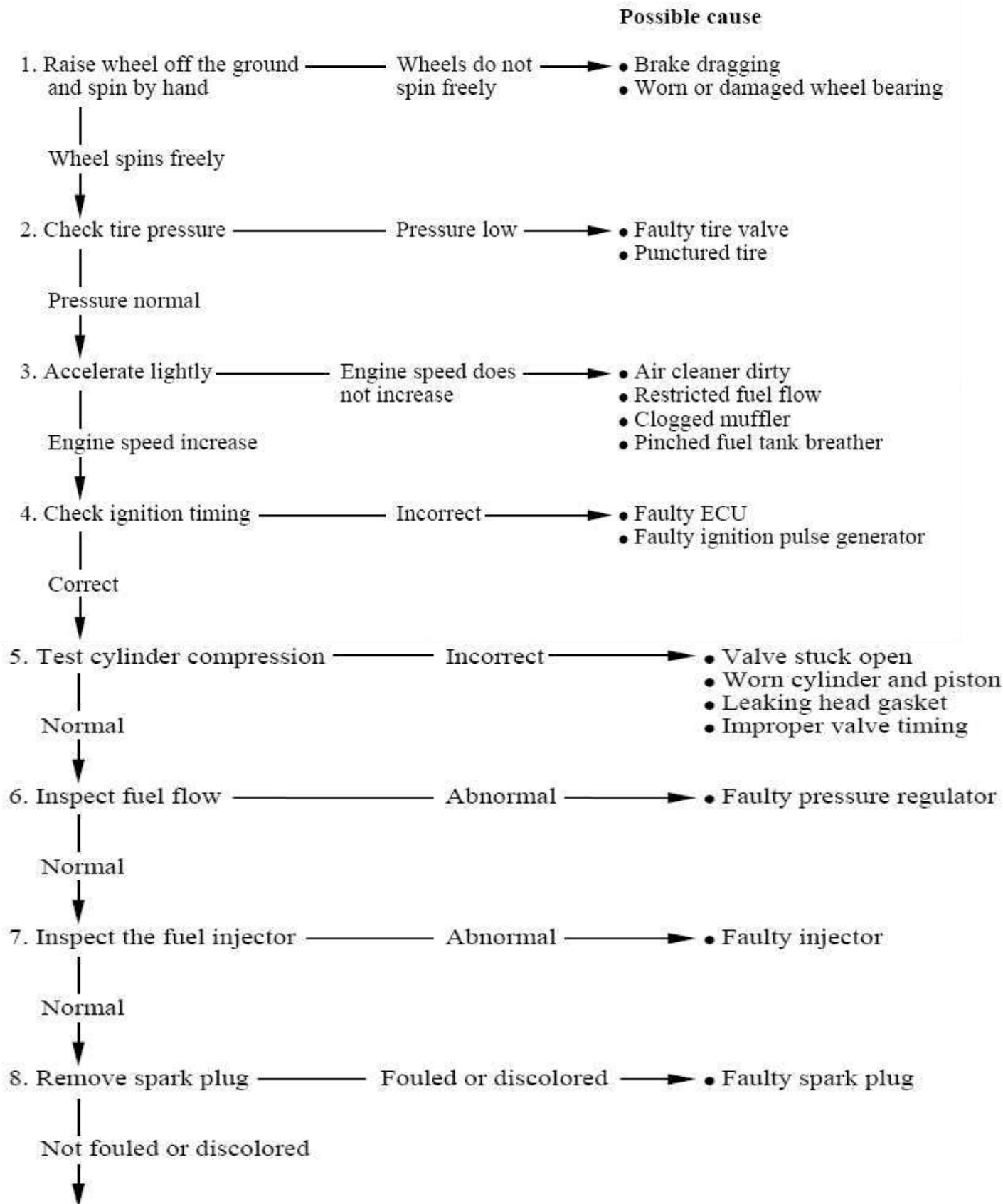

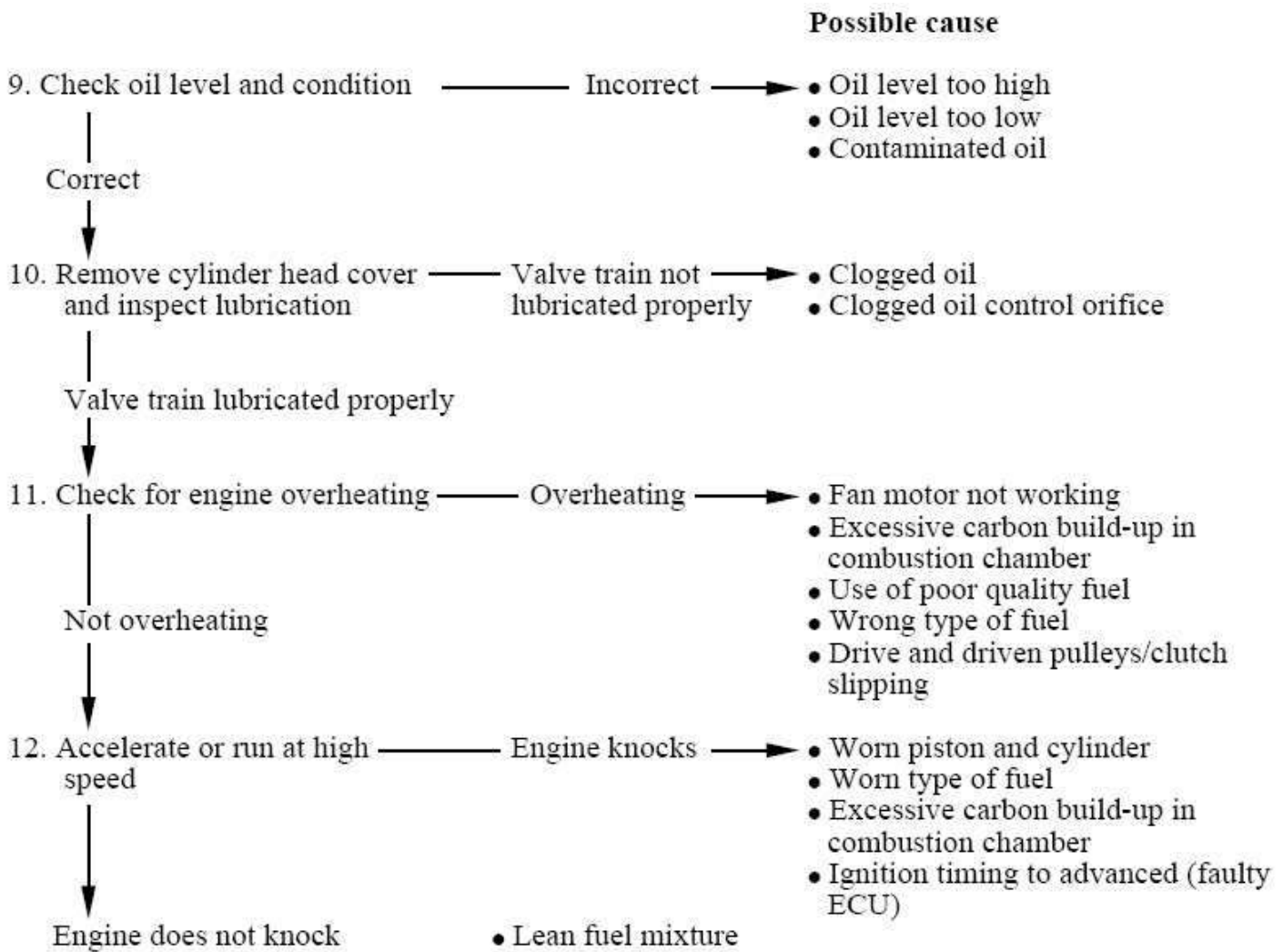

POOR PERFORMANCE AT LOW AND IDLE SPEED

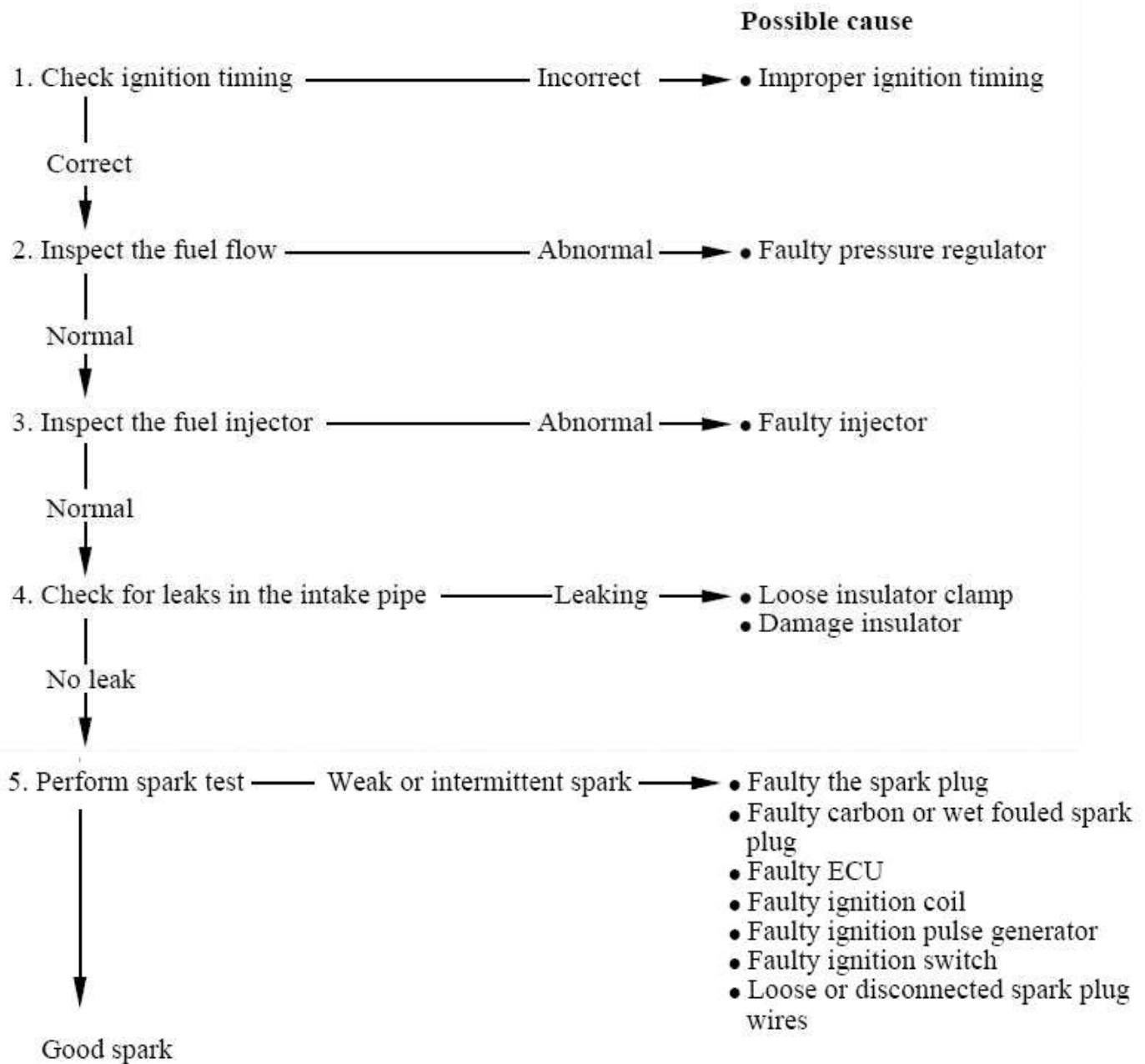

POOR PERFORMANCE AT HIGH SPEED

Possible cause

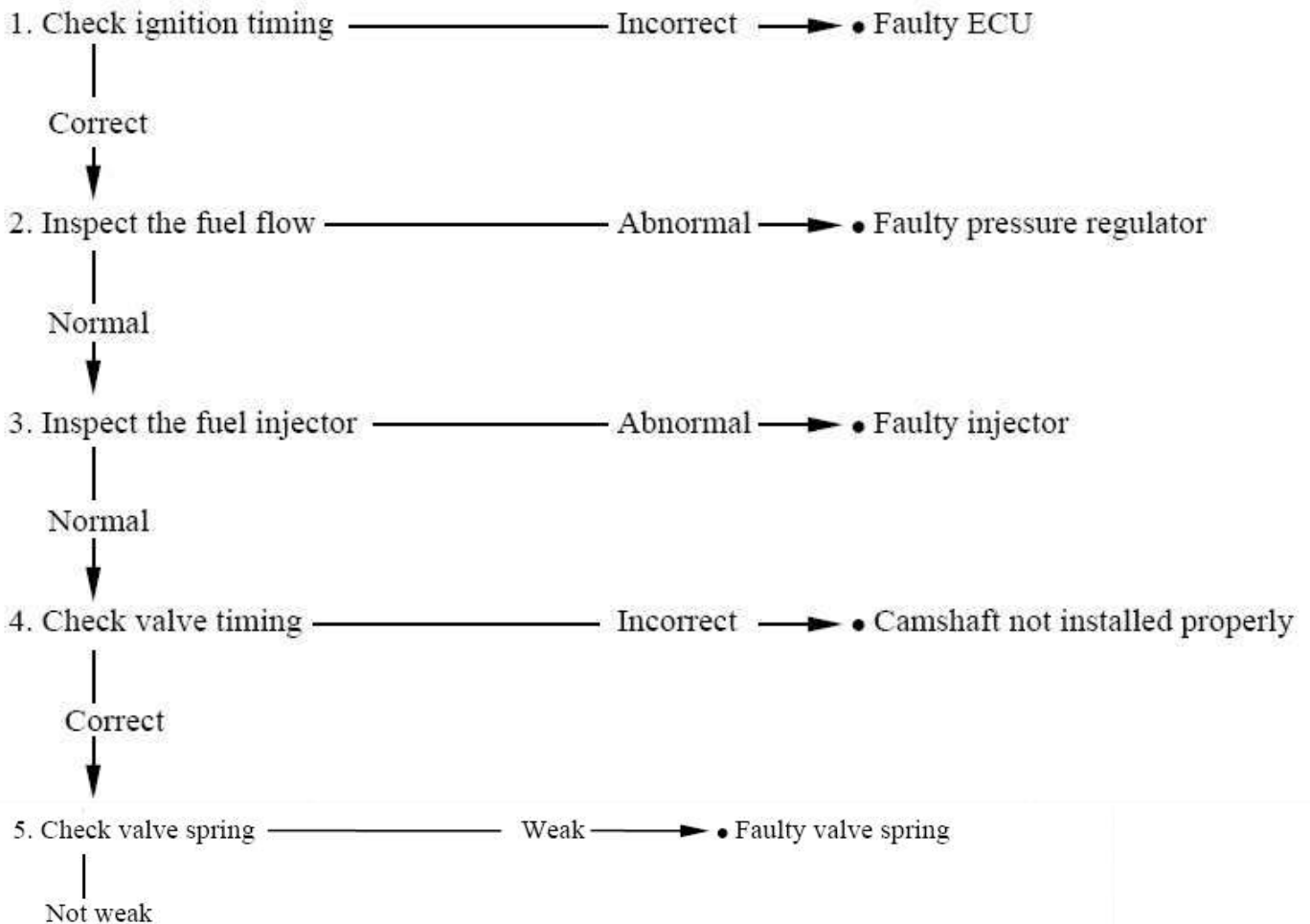

POOR HANDLING

Possible cause

1. If steering is heavy →
 - Steering stem adjusting nut too tight
 - Damaged steering head bearings
2. If either wheel is wobbling →
 - Excessive wheel bearing play
 - Bent rim
 - Improper installed wheel hub
 - Swing arm pivot bearing excessively worn
 - Bent frame
3. If the motorcycle pulled to one side →
 - Faulty the shock absorber
 - Front and rear wheel not aligned
 - Bent fork
 - Bent swing arm
 - Bent axle

INSPECTION/ADJUSTMENT

SERVICE INFORMATION	3- 1
MAINTENANCE SCHEDULE	3- 2
BRAKE SYSTEM	3- 3
MOVING DEVICE	3- 5
DAMPING DEVICE	3- 6
POWER DRIVE SYSTEM.....	3- 6
ELECTRICAL EQUIPMENT.....	3- 7
FUEL SYSTEM	3-10
OTHERS	3-11

3. INSPECTION/ADJUSTMENT

LIKE 200i

SERVICE INFORMATION

GENERAL

WARNING

- Before running the engine, make sure that the working area is well ventilated. Never run the engine in a closed area. The exhaust contains poisonous carbon monoxide gas, which may cause death to people.
- Gasoline is extremely flammable and is explosive under some conditions. The working area must be well ventilated and do not smoke or allow flames or sparks near the working area or fuel storage area.

SPECIFICATIONS

ENGINE

Throttle grip free play : 2~6mm
Spark plug : NGK: CR7HSA
Spark plug gap : 0.6 mm ~ 0.7 mm
Valve clearance : IN: 0.1mm EX: 0.1mm
Idle speed : 1700±100 rpm

Engine oil capacity:

At disassembly : 1.1 Liter
At change : 0.9 Liter

Cylinder compression : 15±2 kg/cm²

Ignition timing : ECU

Coolant type : air-Cooled

Gear oil capacity :

At disassembly : 0.20 Liter
At change : 0.18 Liter

TIRE

	1 Rider	2 Riders
Front	1.75 kg/cm ²	1.75 kg/cm ²
Rear	2.0 kg/cm ²	2.25 kg/cm ²

TIRE SPECIFICATION:

Front : 120/70-12
Rear : 130/70-12

TORQUE VALUES

Front axle nut : 65 N-m
Rear axle nut : 120 N-m

3. INSPECTION/ADJUSTMENT

LIKE 200i

MAINTENANCE SCHEDULE

In order to have a safe riding, maintain good performance, prolong the scooter service life and reduce pollution, make sure to perform the periodic inspection and maintenance.

I: Inspect and clean, lubricate, refill, repair or replace if necessary.

A: Adjust C: Clean R: Replace T: Tighten D: Inspect with Diagnosis Instrument

Item	4Stroke	Regular service mileage (KM)								Daily Inspection
		300	1000	3000	5000	7000	9000	11000	13000	
Engine Oil	○	R	R	R	R	R	R	R	R	
Engine Oil Strainer	○	C		C		C		C		
Gear Oil	○	R		R		R		R		
Spark Plug	○	Clean at every 2000KM and replace at every 5000KM								
Valve Clearance	○	A		A		A		A		
Drive Belt	○					I				
Bolts & Nuts	○	T			T			T		
Air Cleaner	○		I	R	I	R	I	R	I	
Tire Pressure	○		I	I	I	I	I	I		
Fuel Filter Screen	○					R				
Break System	○		I	I	I	I	I	I	I	I
Throttle Body	○		D			D			D	
Fuel Nozzle	○		D			D			D	
Idle Air Bypass Valve	○		D			D			D	
Engine Temperature Sensor	○		D			D			D	
Temperature-MAP Sensor	○		D			D			D	
TILT Sensor	○		D			D			D	

The above items are applicable to different models. Perform suitable items for each model.
 When exceeding the listed mileages, perform maintenance according to the listed intervals.
 The air cleaner requires more frequent cleaning or replacing when ridden in unusually dusty areas.

BRAKE SYSTEM

Inspect the brake fluid level.
Recommend brake fluid: DOT4

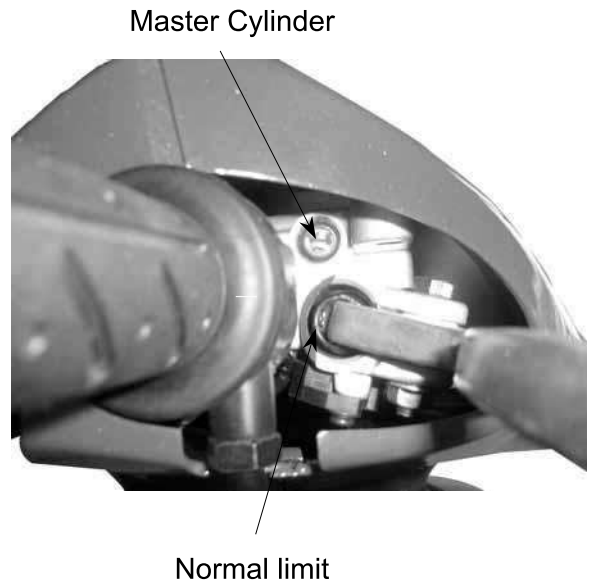

BRAKE LEVER

Measure the front and rear brake lever free plays.

Free Play: Rear: 10~20mm

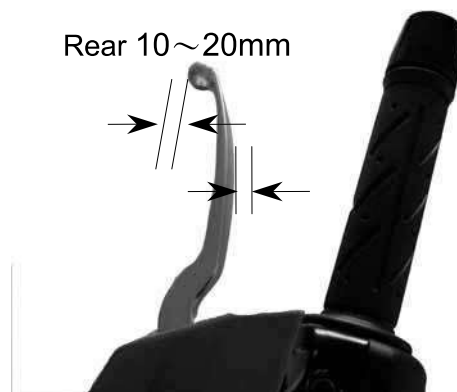

BRAKE DISK/LINING

《 Brake Disk Surface and Brake Pad Wear 》

Check the brake disk surface for scratch. Check if the brake pad wear is within the specified service limit.

《 Brake Disk Run-out Inspection 》

Stand the motorcycle wheels off the ground and check if the brake disk run-out is within the specified service limit.



Brake Disk

BRAKE FLUID LEVEL INSPECTION

《 Brake Master Cylinder Fluid Level Inspection 》

Turn the steering handlebar upright and check if the front brake fluid level is within the specified limits through the front brake master cylinder check hole.

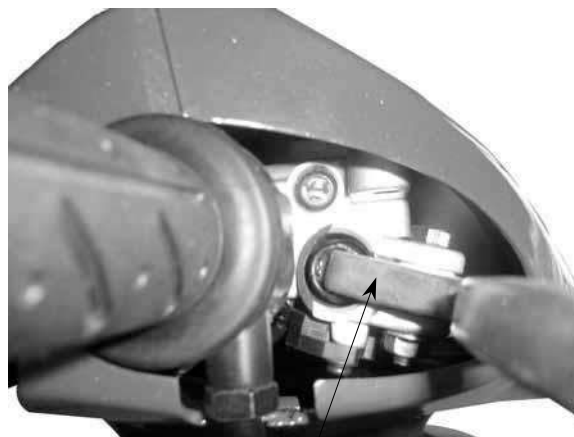

Brake Master Cylinder

MOVING DEVICE

TIRES

《Tire Pressure》

Check the tire pressure.

* Tire pressure should be checked when tires are cold.

Tire Pressure (one rider)

Front: 1.75 kg/cm²

Rear: 2.25 kg/cm²

Tire Size

Front	120/70 – 12
Rear	130/70 – 12

《Axle Nut/Axle Shaft Looseness》

Check the front and rear axle nuts for looseness.

If the axle nuts are loose, tighten them to the specified torques.

Torques:

Front: 5.0~7.0kg-m

Rear: 11.0~13.0kg-m

《Wheel Rim/Spoke Plate Damage》

Check the wheel rim and spoke plate for wear or damage and measure the rim runout.



Front Wheel



Axle Nut

Rear Wheel



Axle Nut

DAMPING DEVICE

SHOCK ABSORBERS

《Oil Leak/Damage》

Fully apply the front brake and check the action of the front shock absorber by compressing it several times.

Check the entire shock absorber assembly for looseness or damage.

Check the action of the rear shock absorber by compressing it several times.

Check the entire shock absorber assembly for looseness or damage.



POWER DRIVE SYSTEM

TRANSMISSION CASE

Check the rear wheel transmission case surrounding area for oil leaks.

Stop the engine and remove the oil check bolt.

* Place the motorcycle on its main stand on level ground.

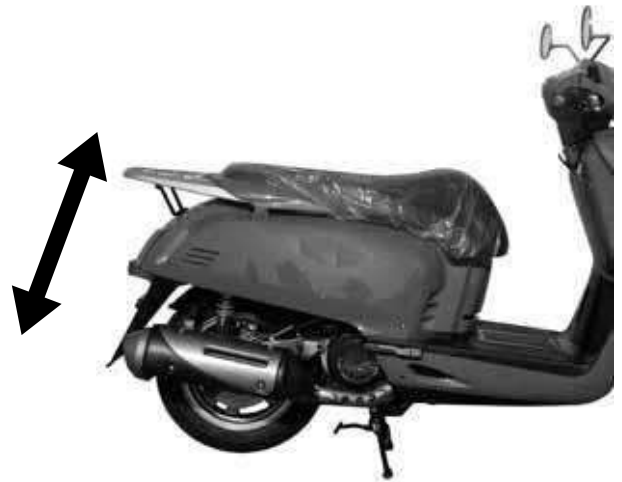

The gear oil level shall be at the oil check bolt hole. If the oil level is low, add the specified oil to the proper level.

Specified Gear Oil: SAE 90#

Install and tighten the oil check bolt.

Torque: 1.0~1.5kg-m

Start the engine and check for oil leaks.



Oil Check Bolt

ELECTRICAL EQUIPMENT

IGNITION APPARATUS

《 Spark Plug 》

Remove the frame center cover.
 Remove the spark plug cap and spark plug.
 Check the spark plug for wear, fouling and carbon deposits.
 Remove the fouling and carbon deposits with a spark plug cleaner or wire brush.

Specified Spark Plug

NGK
SF10JA
CR7HSA

Spark Plug Gap: 0.6~0.7mm

《 Ignition Apparatus 》

* The CDI ignition timing is not adjustable. If the timing is incorrect, check the CDI unit, ignition coil and A.C. generator and replace any faulty parts.

Remove the right side rail. (⇒12-4)
 Remove the A.C. generator fan cover. (⇒7-3)
 Remove the three bolts attaching the fan cover and then remove the fan cover.
 Warm up the engine and check the ignition timing with a timing light.

When the engine is running at the specified rpm, the ignition timing is correct if the "F" mark on the flywheel aligns with the index mark on the crankcase within $\pm 1.5^\circ$.

Ignition Timing:

$13.5^\circ \pm 1^\circ$ BTDC/2000rpm

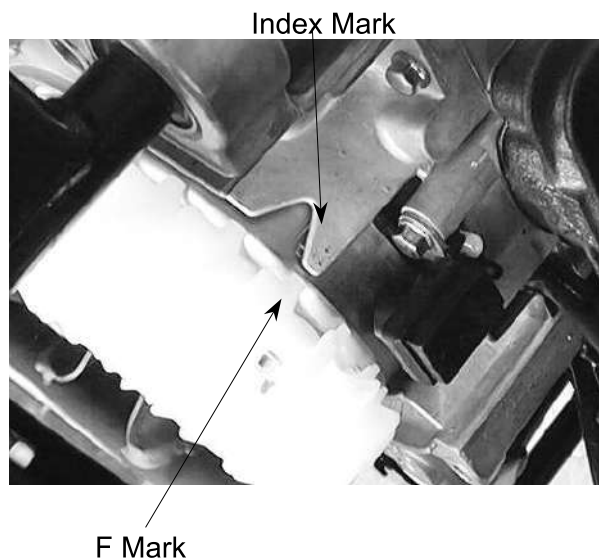
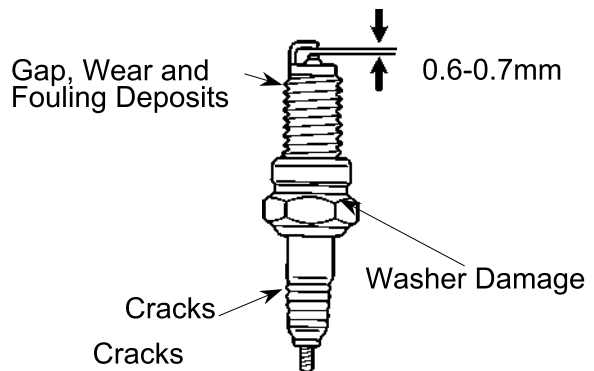

《 Air Cleaner 》

Remove the air cleaner cover by removing the seven bolts cleaner cover screws.

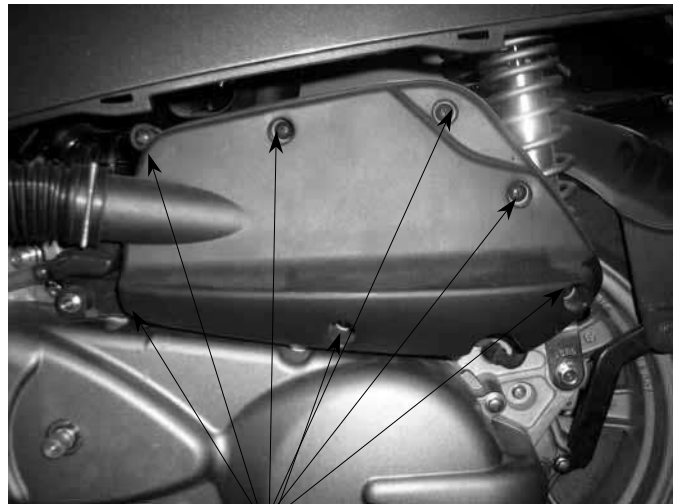

Screws

Remove the air cleaner element.



Air Cleaner

Wash the air cleaner element in detergent oil, squeeze out and allow to dry.

* Never use gasoline or organic vaporable oil with acid or alkali for washing.

After washing, soak the element in clean engine oil SAE 10W-30# and squeeze out excess oil. Reinstall the element.

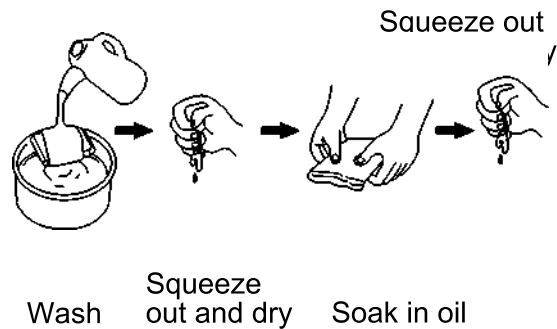

《Cylinder Compression》

* Warm up the engine before compression test.

Remove the spark plug and insert a compression gauge. Open the throttle valve fully and push the starter button for 7~8 seconds to test the compression.

Compression:
15kg/cm²

If the compression is low, check for the following:

- Leaking cylinder head gasket
- Worn piston/cylinder

If the compression is high, it indicates that carbon deposits have accumulated on the combustion chamber and the piston head.



FUEL SYSTEM

《Throttle Grip Free Play》

Measure the throttle grip free play.

Free Play: 2~6mm

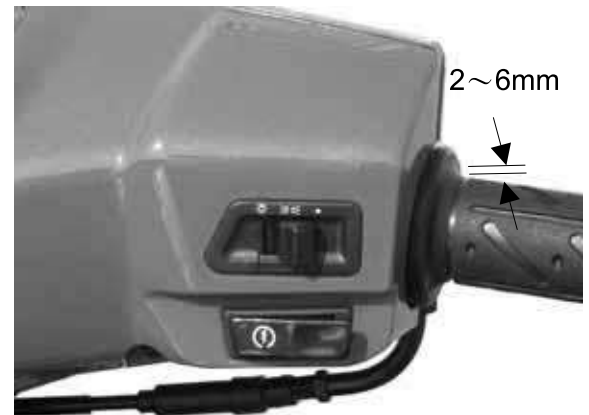

Lock Nut

If the throttle grip free play does not fall within the specified range, adjust by loosening the lock nut and turning the adjusting nut.



Adjusting Nut

Adjusting Nut



Major adjustment of the throttle grip free play is made with the adjusting nut at the throttle body side. Adjust by loosening the lock nut and turning the adjusting nut.

OTHERS

LIGHTS

《Headlight》

Front upper cover remove. (12⇒5)

Adjust the headlight beam by loosening the headlight adjusting bolt and moving the adjusting bolt forward and backward to a proper position. Tighten the adjusting bolt.



Headlight

LUBRICATION SYSTEM

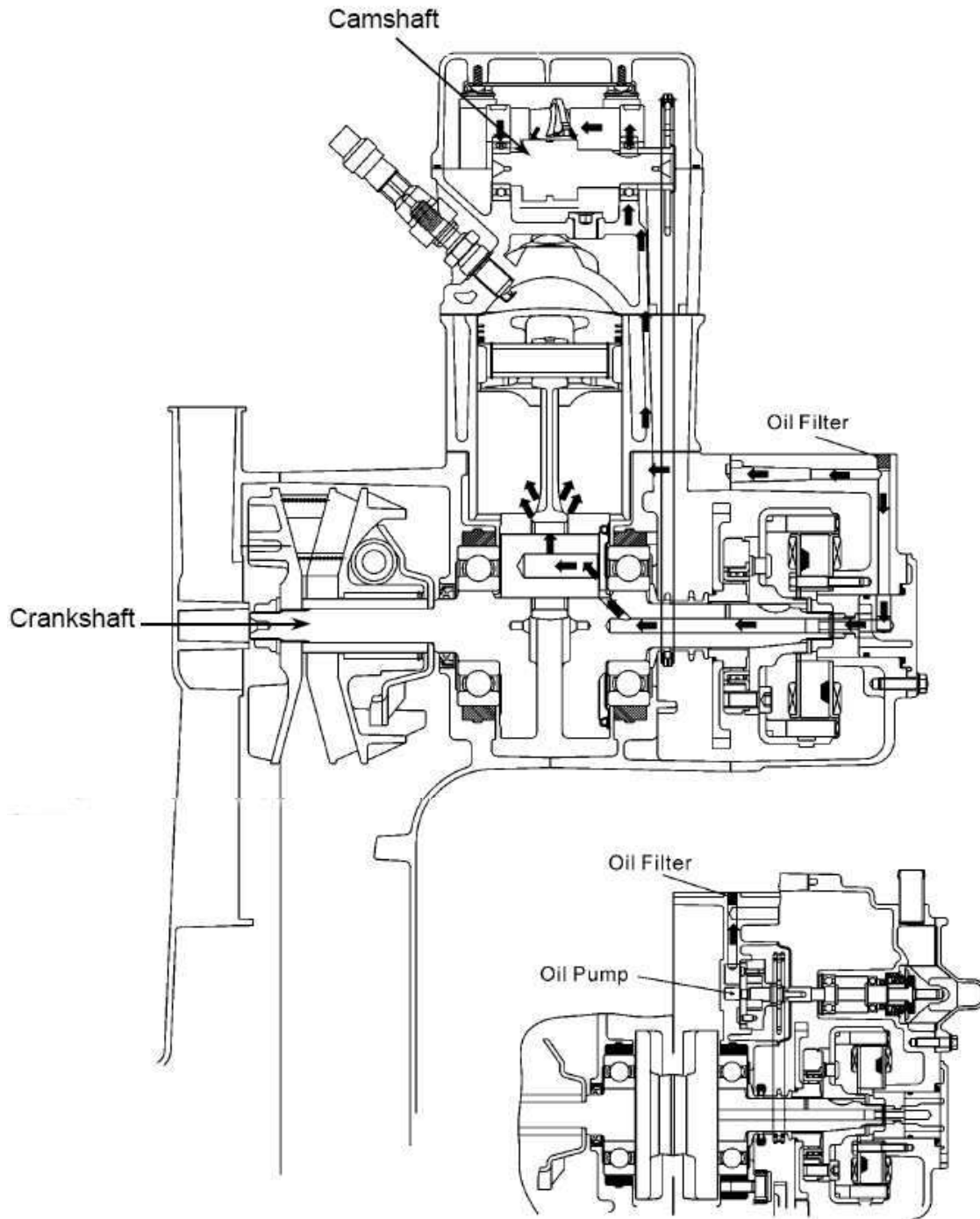

SERVICE INFORMATION

GENERAL INSTRUCTIONS

- The maintenance of lubrication system can be performed with the engine installed on the frame.
- Drain the coolant before starting any operations.
- Carefully when removing and installing the oil pump not to allow dust and foreign matters to enter the engine and oil line.
- Do not attempt to disassemble the oil pump. The oil pump must be replaced as a set when it reaches its service limit.
- After the oil pump is installed, check each part for oil leaks.

SPECIFICATIONS

OIL PUMP

	Standard (mm)	Service Limit (mm)
Inner rotor-to-outer rotor clearance	0.15	0.20
Outer rotor-to-pump body clearance	0.15~0.20	0.25
Rotor end-to-pump body clearance	0.04~0.09	0.12

ENGINE OIL

Engine Oil Capacity	At disassembly: 1.1 liter	At change: 0.9 liter
Recommended Oil	SAE10W40# API: SJ	

TROUBLESHOOTING

Oil level too low

- Natural oil consumption
- Oil leaks
- Worn piston rings
- Worn valve guide
- Worn valve guide seal

Poor lubrication pressure

- Oil level too low
- Clogged oil filter or oil passage
- Faulty oil pump

Oil contamination

- Oil not changed often enough
- Faulty cylinder head gasket
- Loose cylinder head bolts

ENGINE OIL OIL LEVEL

* _____

- Place the motorcycle upright on level ground for engine oil level check.
- Run the engine for 2~3 minutes and check the oil level after the engine is stopped for 2~3 minutes.

Remove the oil dipstick and check the oil level with the oil dipstick.
If the level is near the lower level, fill to the upper level with the specified engine oil.

OIL CHANGE

* _____

The engine oil will drain more easily while the engine is warm.

Remove the oil filter screen cap located on the bottom of the engine to drain the engine oil thoroughly.

After the oil has been completely drained, check the filter screen O-ring for damage and replace if necessary. Install the oil filter screen, spring and filter screen cap.

Torque: 1.5kg-m

Fill with the specified SAE10W40#, API: SG/CD engine oil to the proper level.

Oil Capacity: At disassembly : 1.1 liter
At change : 0.9 liter

Check for oil leaks and then start the engine and let it idle for few minutes. Recheck the oil level.

OIL PUMP REMOVAL

Drain the coolant.

Remove the right crankcase cover. (⇒10-3)

Remove the A.C. generator starter driven gear. (⇒10-3)

Remove the attaching bolts and oil separator cover.



Oil Dipstick

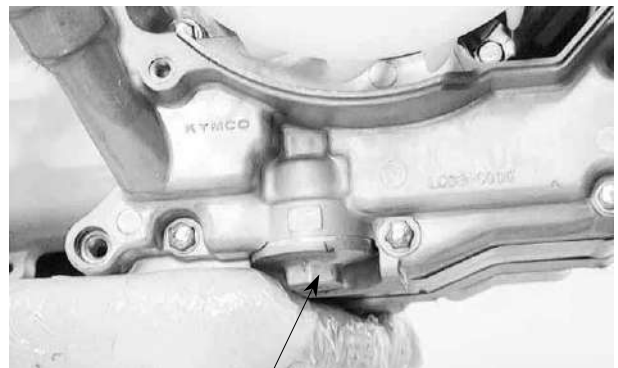

Oil Filter Screen Cap



Bolts



Oil Separator Cover

4. LUBRICATION SYSTEM

LIKE 200i

Spread the clip off and remove the oil pump driven gear, then remove the oil pump drive chain.

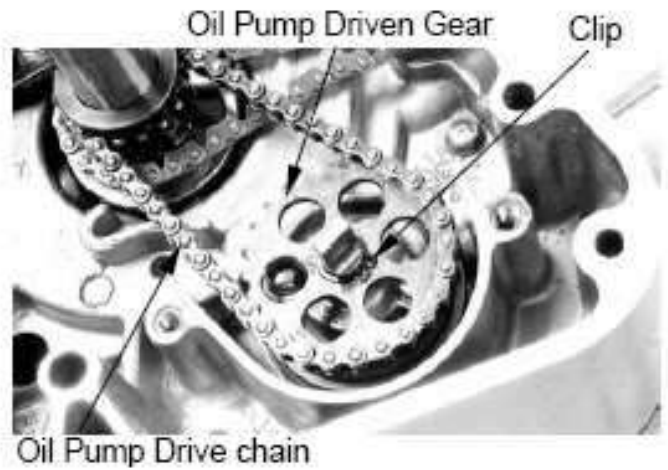

Remove the two oil pump bolts to remove the oil pump.

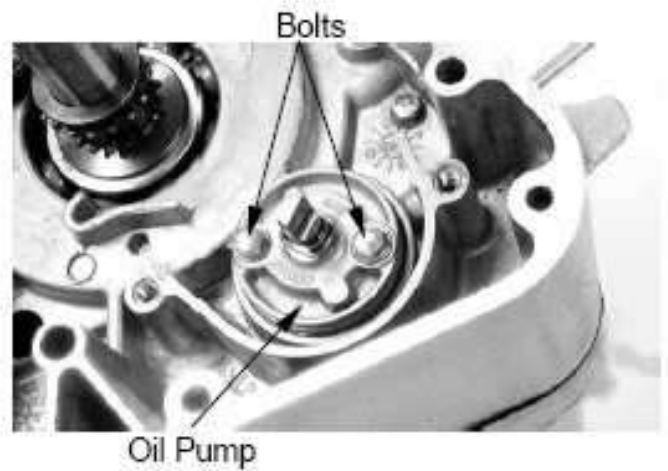

OIL PUMP DISASSEMBLY

Remove the screws and disassemble the oil pump as shown.



OIL PUMP INSPECTION

Measure the pump body-to-outer rotor clearance.

Service Limit: 0.25 mm replace if over

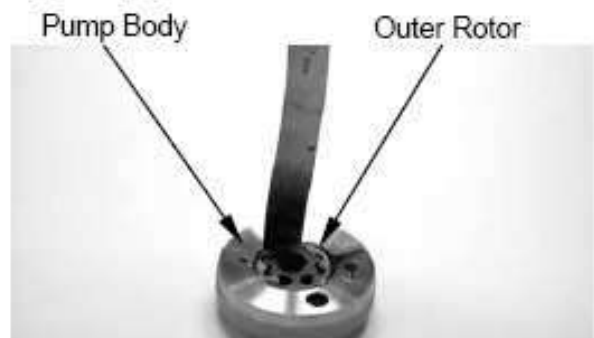

Measure the inner rotor-to-outer rotor clearance.

Service Limit: 0.20 mm replace if over

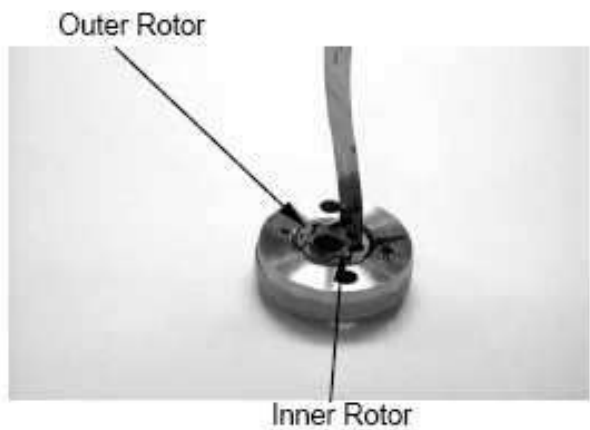

Measure the rotor end-to-pump body clearance.

Service Limit: 0.12 mm replace if over

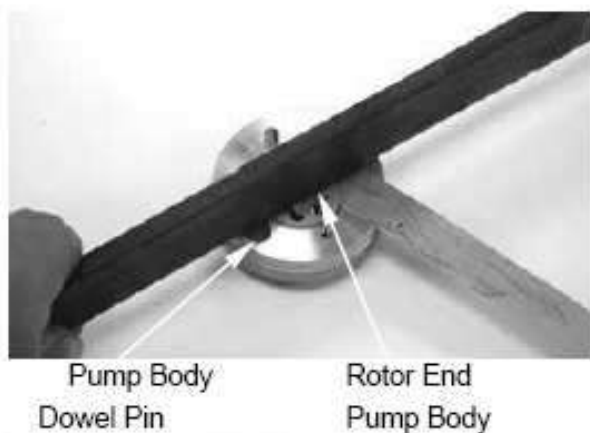

OIL PUMP ASSEMBLY

Install the outer rotor, inner rotor and pump shaft into the pump body.

* Insert the pump shaft by aligning the flat on the shaft with the flat in the inner rotor. Install the dowel pin.

There is one mark on the surface of the inner rotor and outer rotor.

The mark is upside.

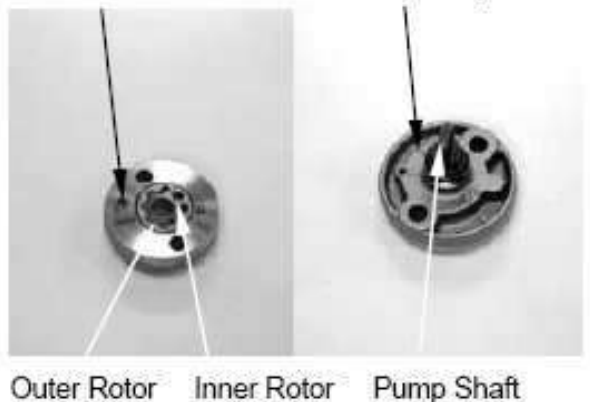

Install the pump cover by aligning the hole in the cover with the dowel pin.
Tighten the screw to secure the pump cover.
Make sure that the pump shaft rotates freely without binding.

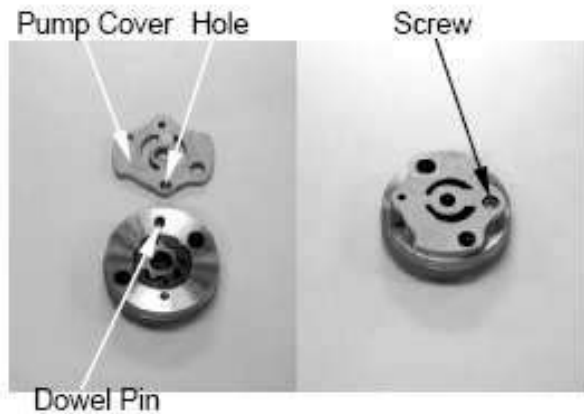

OIL PUMP INSTALLATION

Install the oil pump and oil separator and tighten the two bolts.
Make sure that the pump shaft rotates freely.
The arrow of oil pump is upside.

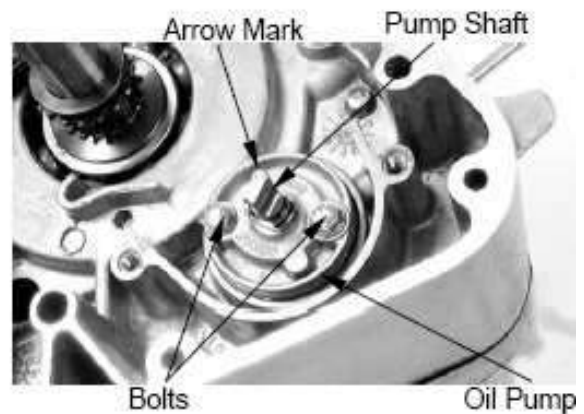

Install the pump drive chain and driven gear, then set the clip securely on the pump shaft.



Install the oil separator cover properly.

* Fit the tab of the separator cover into the slit in the separator.

Install the A.C. generator starter driven gear.
(≈10-8)

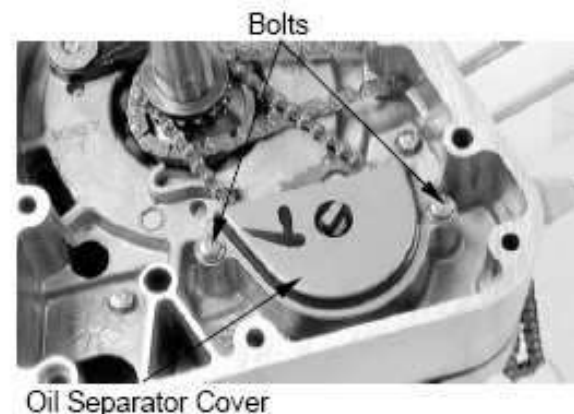

ENGINE REMOVAL/INSTALLATION

SERVICE INFORMATION 5-2
ENGINE REMOVAL 5-3
ENGINE INSTALLATION 5-6

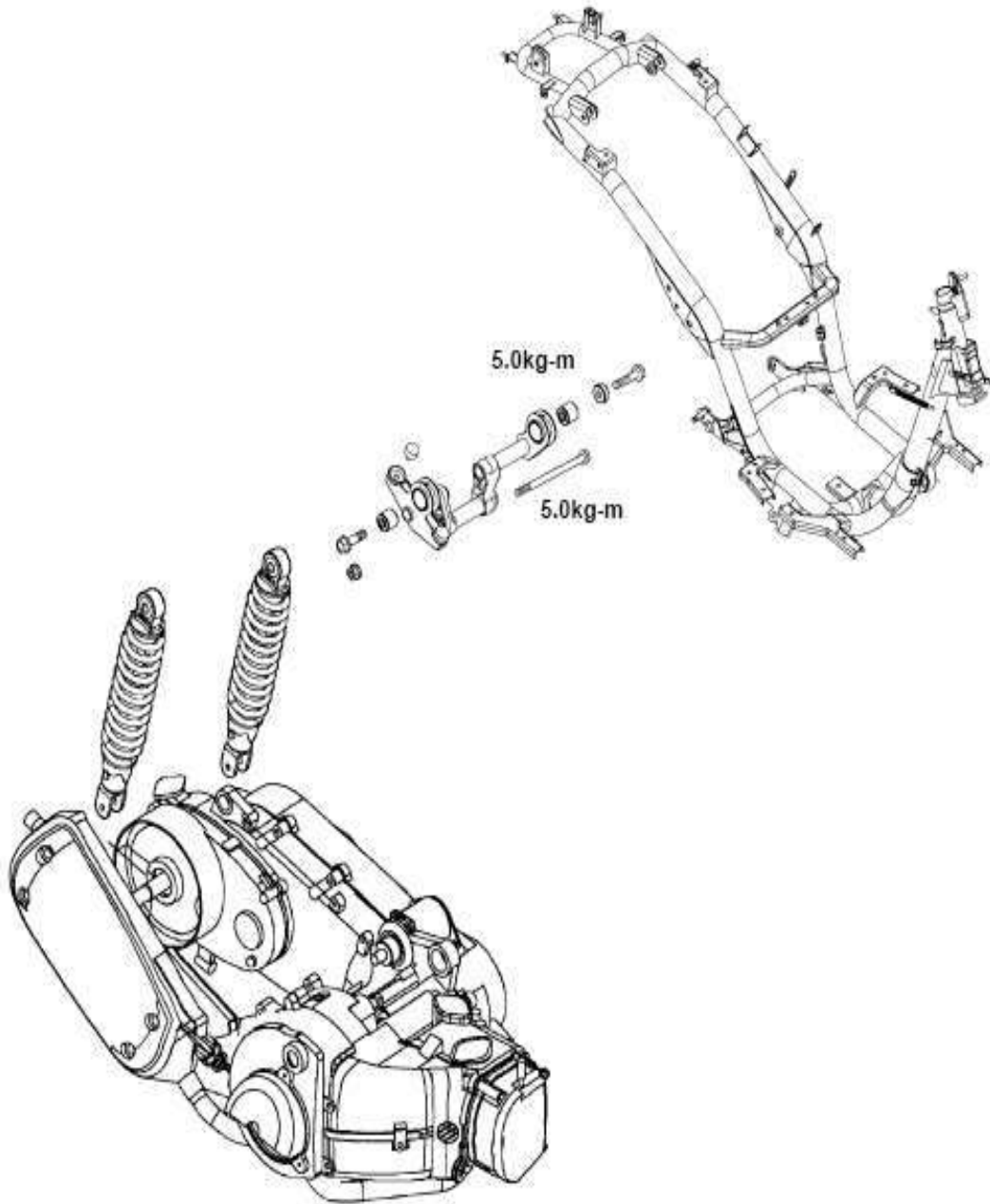

SERVICE INFORMATION

GENERAL INSTRUCTIONS

- A jack or other adjustable support is required to support and maneuver the engine. Be careful not to damage the motorcycle body, cables and wires during engine removal.
- Use towels to protect the motorcycle body during engine removal.
- Drain the coolant before removing the engine.
- After the engine is installed, fill the cooling system with coolant and be sure to bleed air. Start the engine to check for coolant leaks.
- Before removing the engine, the rear brake caliper must be removed first. Be careful not to bend or twist the brake fluid tube.

SPECIFICATIONS

Engine oil capacity: 1.1 Liter

TORQUE VALUES

Rear shock absorber upper mount bolt	40 N-m
Rear shock absorber lower mount bolt	40 N-m
Rear axle nut	120 N-m
Engine hanger bolt (frame side)	50 N-m
Engine hanger bolt (ENG. side)	50 N-m
Rear caliper holder bolt	27 N-m
Exhaust muffler pipe nut	20 N-m
Exhaust muffler bracket bolt (attached to RR Fork)	35 N-m
Rear fork bolt (attached to ENG case)	32 N-m

ENGINE REMOVAL

Disconnect the battery negative cable.
Remove the frame body cover. (⇒12)
Disconnect the engine negative cable.
Disconnect the spark plug high tension wire.
Disconnect the auto bystarter wire connector.
Disconnect the A.C.G. wire connector.

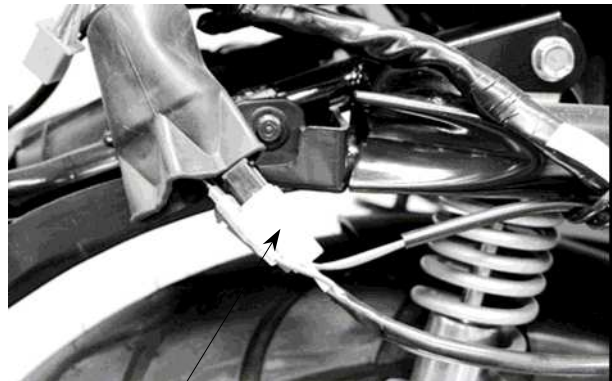

A.C.G. Wire Connector

Disconnect the starter motor cable from the starter relay.
Remove the spark plug cap.



Starter Relay

Remove the bolt and disconnect the fuel tube at the fuel injector.
Disconnect the vacuum tube.
Disconnect the engine temperature sensor connector.
Loosen the air ventilation hose band screw.

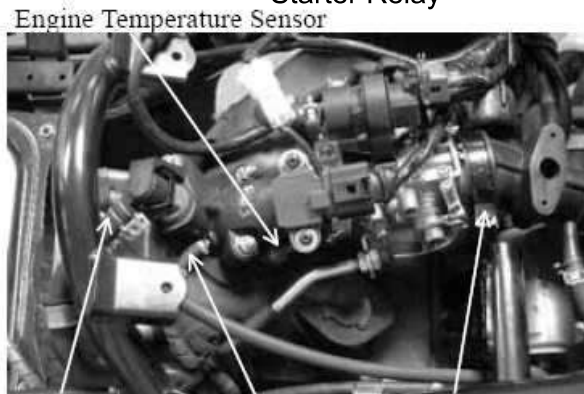

Fuel Tube Vacuum Tube Band Screw

Loosen the intake manifold band (air cleaner tube and inlet pipe).
Disconnect the radiator air ventilated tube and thermosensor wire coupler from thermostat.



Radiator air ventilated tube Thermosensor

5. ENGINE REMOVAL/INSTALLATION

LIKE 200i

Disconnect the engine oil pressure switch wire.

Loosen the water hose bands to disconnect water hoses from the water ducts.

Disconnect the secondary air tube from the secondary air inlet tube.

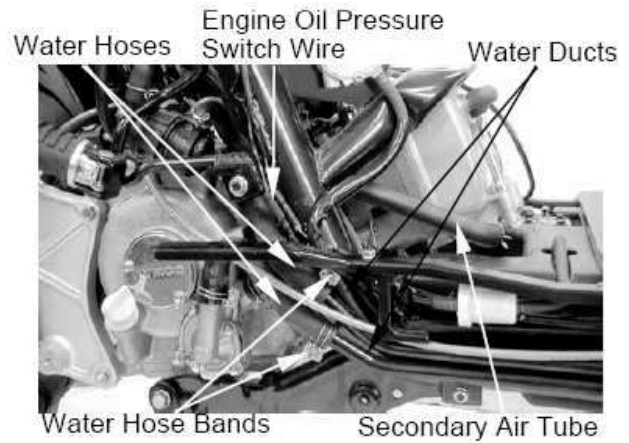

Disconnect the breather hose (air cleaner) from cylinder head cover.

Disconnect the spark plug cap from cylinder head.

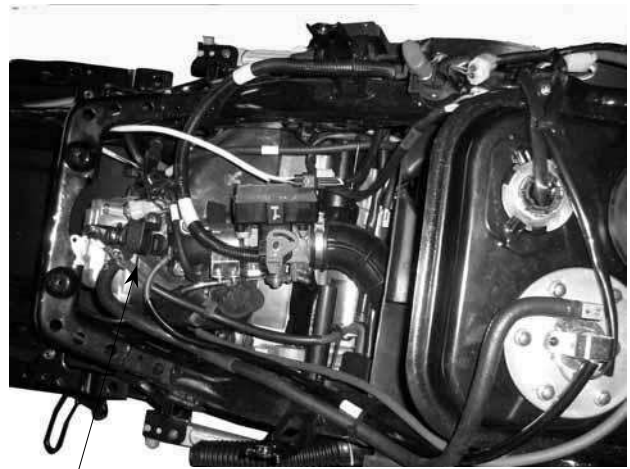

Remove the screws attaching the rear fender C.

Remove two bolts on the air cleaner.



Remove the battery connection wire.



Wire

Remove the rear shock absorbers mounting bolts.



Rear Shock Absorber Bolts

Bolts

Remove the engine mounting bolt and pull out the engine with the engine hanger bracket backward.



ENGINE HANGER BRACKET REMOVAL

Remove the ignition coil from the engine hanger.

Remove the engine hanger bracket bolt and nut.

Remove the engine.

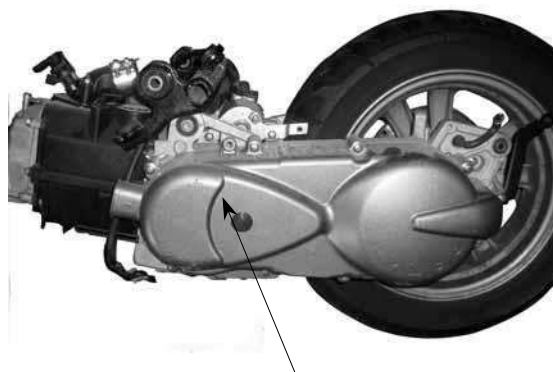

Engine

Remove the engine hanger bracket.
Inspect the engine hanger bushings and stopper rubbers for wear or damage.



ENGINE HANGER BRACKET INSTALLATION

Install the engine hanger bracket to the engine.

Install and tighten the engine hanger bracket bolts.

ENGINE INSTALLATION

Install the engine and tighten the engine mounting bolts.

Torque: 5.0kg-m

Tighten the rear shock absorbers mounting bolts.

Torque: Up side 4.0kg-m

Down side 2.5kg-m

Install the removed parts in the reverse order of removal.

Engine Hanger Bracket Bolt Bushings

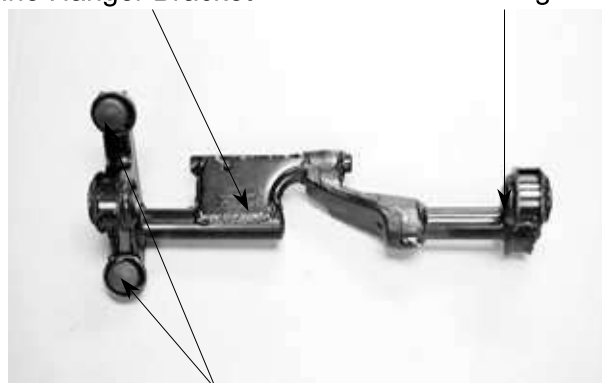

Stopper Rubbers

Tire pressure should be checked when tires are cold.

After installation, inspect and adjust the following:

- Throttle grip free play (⇒3-3)
- Rear brake adjustment (⇒3-8)



CYLINDER HEAD/VALVES

SCHEMATIC DRAWING.....	6-1
SERVICE INFORMATION.....	6-2
TROUBLESHOOTING	6-3
CYLINDER HEAD COVER REMOVAL	6-4
CAMSHAFT REMOVAL.....	6-4
CYLINDER HEAD REMOVAL.....	6-6
CYLINDER HEAD DISASSEMBLY	6-7
CYLINDER HEAD ASSEMBLY	6-8
CYLINDER HEAD INSTALLATION.....	6-9
CAMSHAFT INSTALLATION.....	6-10
CYLINDER HEAD COVER INSTALLATION	6-11

SERVICE INFORMATION

GENERAL INSTRUCTIONS

- The cylinder head can be serviced with the engine installed in the frame. Coolant in the radiator and water hoses must be drained.
- When assembling, apply molybdenum disulfide grease or engine oil to the valve guide movable parts and valve arm sliding surfaces for initial lubrication.
- The valve rocker arms are lubricated by engine oil through the engine oil passages. Clean and unplug the oil passages before assembling the cylinder head.
- After disassembly, clean the removed parts and dry them with compressed air before inspection.
- After removal, mark and arrange the removed parts in order. When assembling, install them in the reverse order of removal.

SPECIFICATIONS		Standard (mm)	Service Limit (mm)
Item			
Valve clearance (cold)	IN	0.10	—
	EX	0.10	—
Cylinder head compression pressure		15 kg/cm ²	—
Camshaft cam height	IN	34.2987	34.14
	EX	34.1721	34.02
Valve rocker arm I.D.	IN	10.00 ~ 10.015	10.10
	EX	10.00 ~ 10.015	10.10
Valve rocker arm shaft O.D.	IN	9.972 ~ 9.987	9.9
	EX	9.972 ~ 9.987	9.9
Valve seat width	IN	1.2	1.8
	EX	1.2	1.8
Valve stem O.D.	IN	4.990 ~ 4.975	4.925
	EX	4.970 ~ 4.955	4.915
Valve guide I.D.	IN	5.00 ~ 5.012	5.03
	EX	5.00 ~ 5.012	5.03
Valve stem-to-guide clearance	IN	0.010 ~ 0.037	0.08
	EX	0.030 ~ 0.057	0.10

TORQUE VALUES

Cam Shaft Holder	24.5N·m	Apply engine oil to threads
Cylinder head cover bolt	8.9 N·m	

SPECIAL TOOL

Valve spring compressor	E063
-------------------------	------

TROUBLESHOOTING

- The poor cylinder head operation can be diagnosed by a compression test or by tracing engine top-end noises.

Poor performance at idle speed

- Compression too low

Compression too low

- Incorrect valve clearance adjustment
- Burned or bent valves
- Incorrect valve timing
- Broken valve spring
- Poor valve and seat contact
- Leaking cylinder head gasket
- Warped or cracked cylinder head
- Poorly installed spark plug

Compression too high

- Excessive carbon build-up in combustion chamber

White smoke from exhaust muffler

- Worn valve stem or valve guide
- Damaged valve stem oil seal

Abnormal noise

- Incorrect valve clearance adjustment
- Sticking valve or broken valve spring
- Damaged or worn camshaft
- Worn cam chain tensioner
- Worn camshaft and rocker arm

6. CYLINDER HEAD/VALVES

LIKE 200i

CYLINDER HEAD COVER REMOVAL

Remove the met-in box, carrier.
Remove the body cover, center cover and rear fender A.
Disconnect the secondary air inlet tube connector and breather hose (air cleaner).

Remove the cylinder head cover four bolts and two nuts attaching the secondary air inlet duct.
Remove the cylinder head cover.

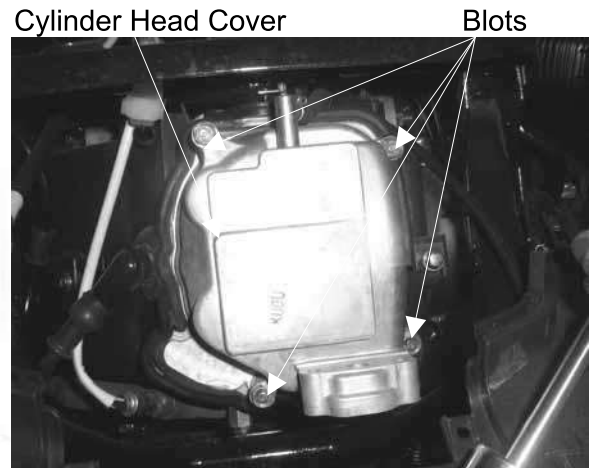

CAMSHAFT REMOVAL

Turn the A.C. generator flywheel so that the "T" mark on the flywheel aligns with the index mark on the right crankcase cover.
Hold the round hole on the camshaft gear facing up and the location is the top dead center on the compression stroke.
Remove the cam chain tensioner cap bolt.

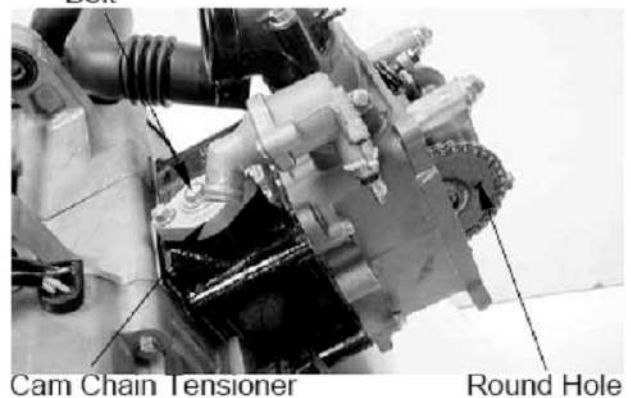

Turn the cam chain tensioner screw clockwise to tighten it.
Remove two bolts attaching the tensioner.

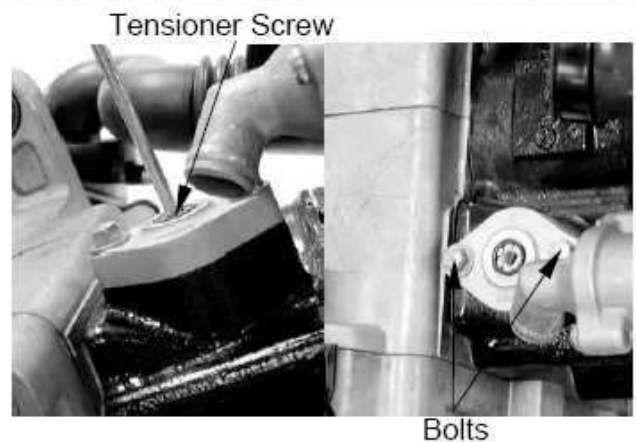

Remove two bolts between the cylinder head and cylinder.
Remove the four cap nuts and washers on the camshaft holder.

- * • Diagonally loosen the cylinder head cap nuts in 2 or 3 times.

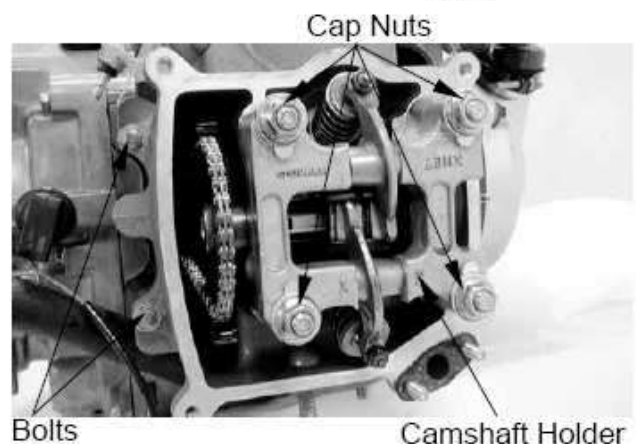

Remove the camshaft holder.



Remove the dowel pins.
Remove the camshaft gear from the cam chain to remove the camshaft.

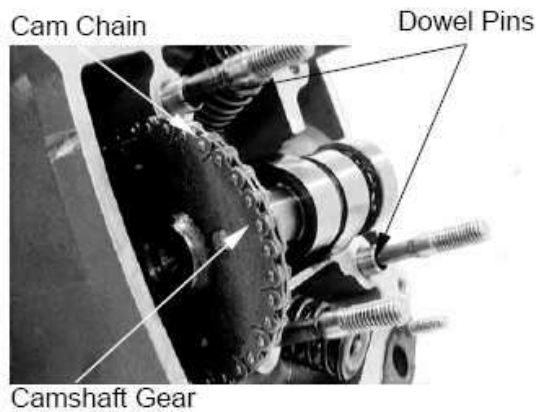

CAMSHAFT INSPECTION

Check each cam lobe for wear or damage.
Measure the cam lobe height.

Service Limits:

IN: 34.14 mm replace if below

EX: 34.02 mm replace if below



Check each camshaft bearing for play or damage. Replace the camshaft assembly with a new one if the bearings are noisy or have excessive play.

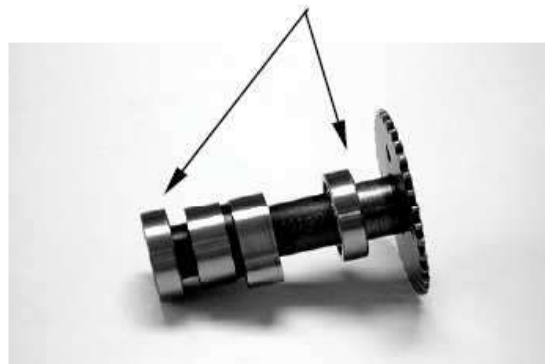

6. CYLINDER HEAD/VALVES

LIKE 200i

CAMSHAFT HOLDER DISASSEMBLY

Remove the valve rocker arms.

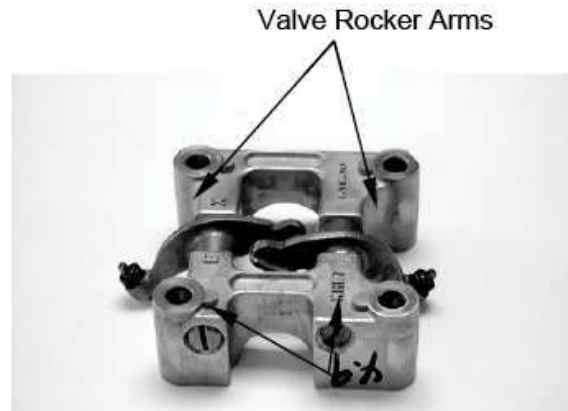

CAMSHAFT HOLDER INSPECTION

Inspect the camshaft holder, valve rocker arms and rocker arm shafts for wear or damage.

* If the surface of valve rocker arm is worn, check each cam lobe for wear or damage.



Measure the I.D. of each valve rocker arm.

Service Limits: IN: 10.10mm replace if over
EX: 10.10mm replace if over

Measure each rocker arm shaft O.D.

Service Limits: IN: 9.90mm replace if below
EX: 9.90mm replace if below



CYLINDER HEAD REMOVAL

Drain the coolant from the radiator and water hose, then remove the thermostat water hose.

Remove the camshaft. (⇒6-4)

Remove the and intake manifold.

Remove the bolt attaching the thermostat housing and the thermostat housing.

Remove the cylinder head.

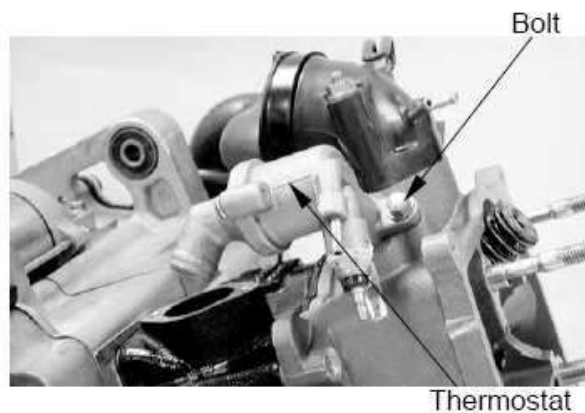

6. CYLINDER HEAD/VALVES

LIKE 200i

Remove the dowel pins and cylinder head gasket.

Remove the cam chain guide.

Remove all gasket material from the cylinder head mating surface.

- * Be careful not to drop any gasket material into the engine.

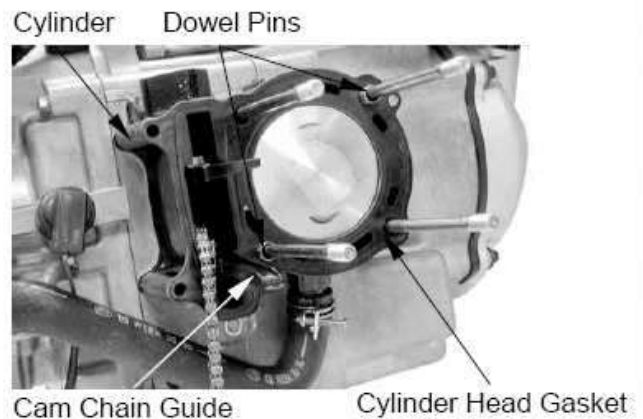

CYLINDER HEAD DISASSEMBLY

Remove the valve spring cotters, retainers, springs, spring seats and valve stem seals using a valve spring compressor.

- * Be sure to compress the valve springs with a valve spring compressor.
- * Mark all disassembled parts to ensure correct reassembly.

Special

Valve spring compressor E063

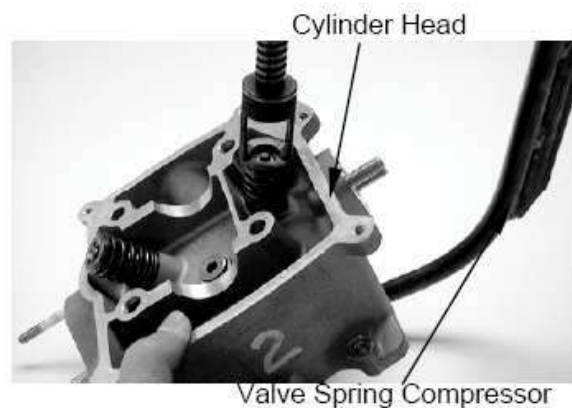

Remove carbon deposits from the exhaust port and combustion chamber.

- * Be careful not to damage the cylinder head mating surface.

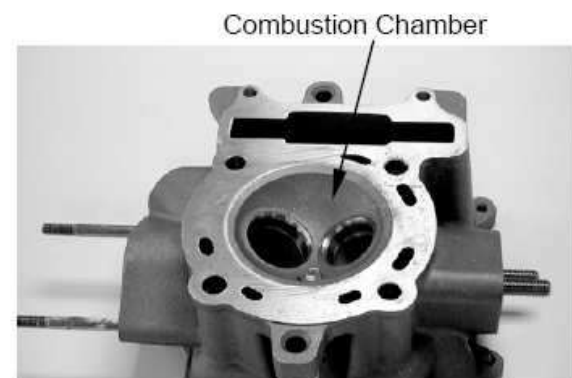

INSPECTION

CYLINDER HEAD

Check the spark plug hole and valve areas for cracks.

Check the cylinder head for flat surface with a straight edge and feeler gauge.

Service Limit: 0.05 mm repair or replace if over

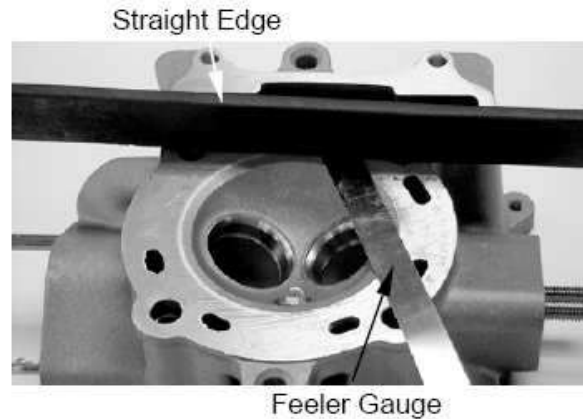

VALVE SPRING FREE LENGTH

Measure the free length of the inner and outer valve springs.

Service Limits:

Inner (IN, EX): 29.5 mm replace if below

Outer (IN, EX): 39.5 mm replace if below



VALVE /VALVE GUIDE

Inspect each valve for bending, burning, scratches or abnormal stem wear.

Check valve movement in the guide.

Measure each valve stem O.D.

Service Limits:

IN: 4.925 mm replace if below

EX: 4.915 mm replace if below



CYLINDER HEAD ASSEMBLY

Install the valve spring seats and stem seals.

Lubricate each valve stem with engine oil and insert the valves into the valve guides.

Be sure to install new valve stem seals.

Special

Valve spring compressor E063

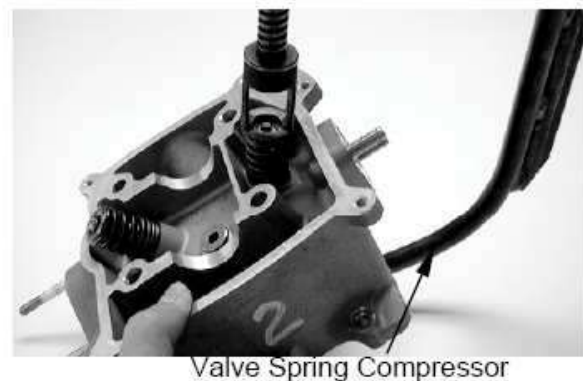

Tap the valve stems gently with a plastic hammer to firmly seat the cotters.

* Be careful not to damage the valves.

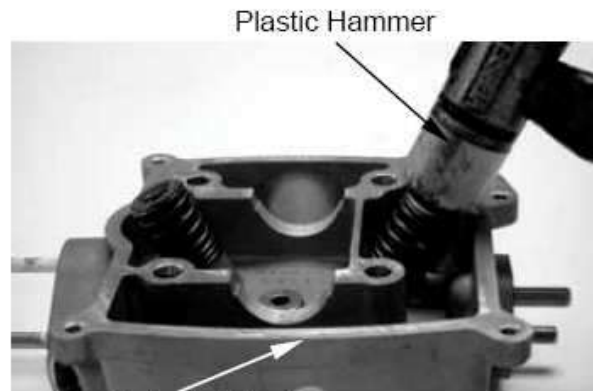

Plastic Hammer
Cylinder Head

CYLINDER HEAD INSTALLATION

Install the cam chain guide.
Install the dowel pins and a new cylinder head gasket.

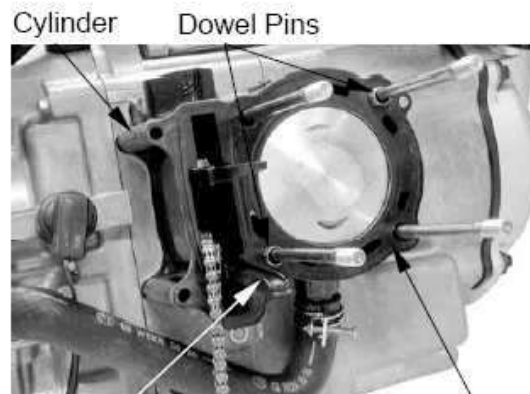

Cylinder Dowel Pins
Cam Chain Guide Cylinder Head Gasket

Install the cylinder head and take out the cam chain

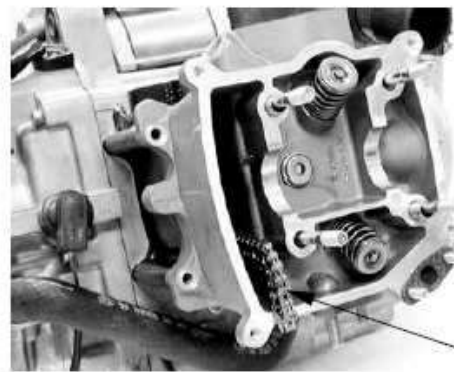

Cam Chain

Assemble the camshaft holder.
First install the intake and exhaust valve rocker arms; then install the rocker arm shafts.

- * • Install the exhaust valve rocker arm shaft on the "EX" side of the camshaft holder and the exhaust rocker arm shaft is shorter.
- Clean the intake valve rocker arm shaft off any grease before installation.
- Align the cutout on the exhaust valve rocker arm shaft with the bolt of the camshaft holder.



Valve Rocker Arms
Camshaft Holder

CAMSHAFT INSTALLATION

Turn the A.C. generator flywheel so that the "T" mark on the flywheel aligns with the index mark on the right crankcase cover.

Keep the round hole on the camshaft gear facing up and align the punch marks on the camshaft gear with the cylinder head surface (Position the intake and exhaust cam lobes down.) and install the cam chain over the camshaft gear.

Install the dowel pins.

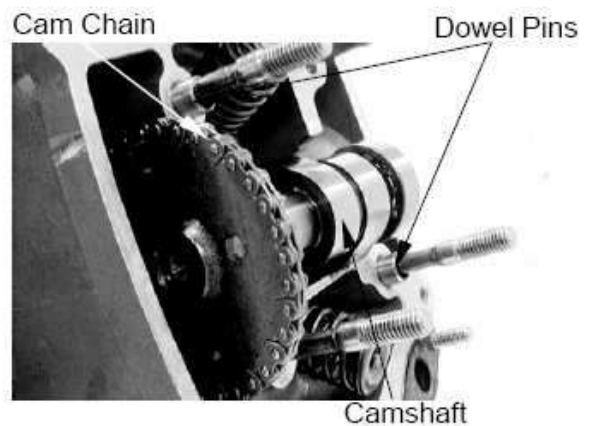
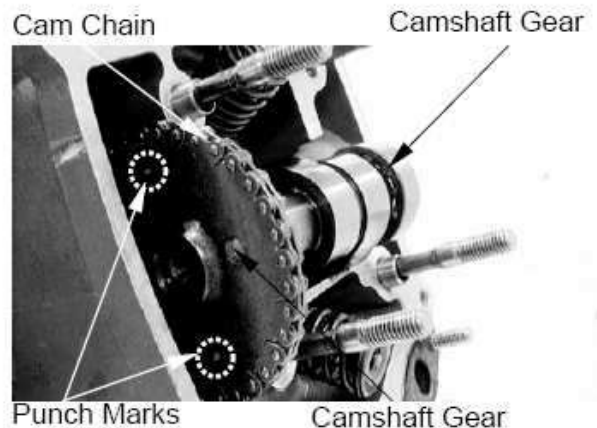

Install the camshaft holder, washers and nuts on the camshaft holder.

Tighten the four cylinder head nuts and the two bolts between the cylinder head and cylinder.

Torque:

Cylinder head cap nut: 24.5N-m

Cylinder & cylinder head bolt: 9.8 N-m

- *
- Apply engine oil to the threads of the cylinder head cap nuts.
 - Diagonally tighten the cylinder head cap nuts in 2~3 times.
 - First tighten the cylinder head cap nuts and then tighten the bolts between the cylinder and cylinder head to avoid cracks.

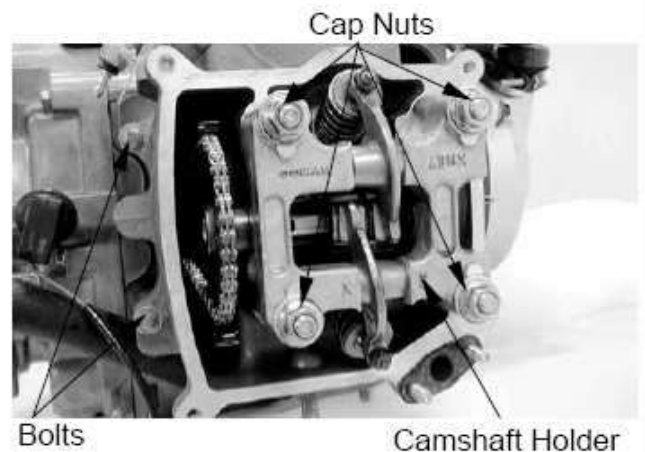

6. CYLINDER HEAD/VALVES

LIKE 200i

Turn the cam chain tension screw counter-clockwise to release it.

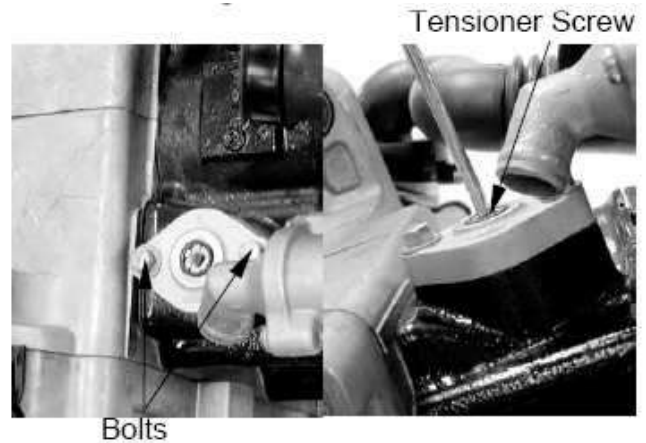

Apply engine oil to a new O-ring and install it. Tighten the cam chain tension cap screw.

* Be sure to install the gasket into the groove properly.



CYLINDER HEAD COVER INSTALLATION

Adjust the valve clearance.
Install a new cylinder head cover O-ring and install the cylinder head cover.

* Be sure to install the O-ring into the groove properly.

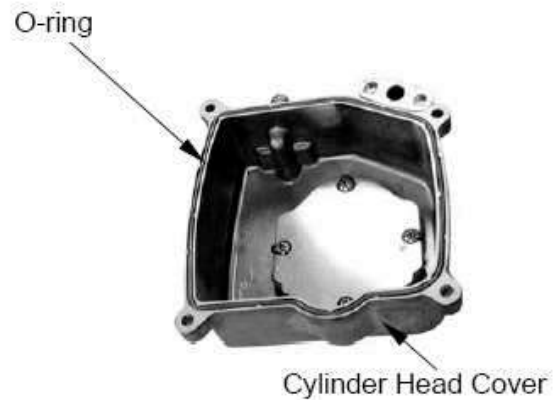

Install and tighten the cylinder head cover bolts and nuts.

Torque: 8.9 N-m

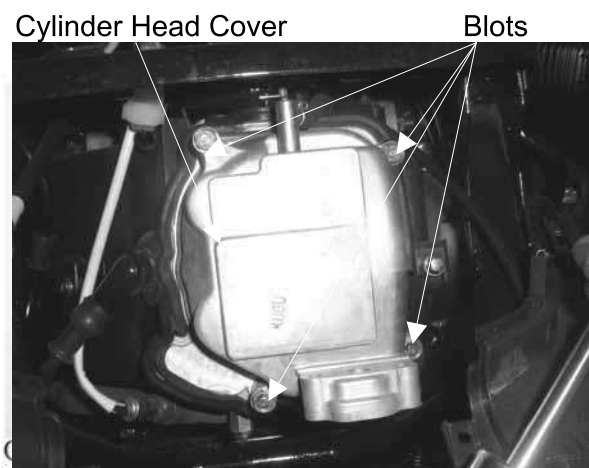



CYLINDER/PISTON



SCHEMATIC DRAWING-----	7-1
SERVICE INFORMATION-----	7-2
TROUBLESHOOTING -----	7-2
CYLINDER REMOVAL-----	7-3
PISTON REMOVAL-----	7-3
PISTON INSTALLATION -----	7-7
CYLINDER INSTALLATION -----	7-7

SCHEMATIC DRAWING

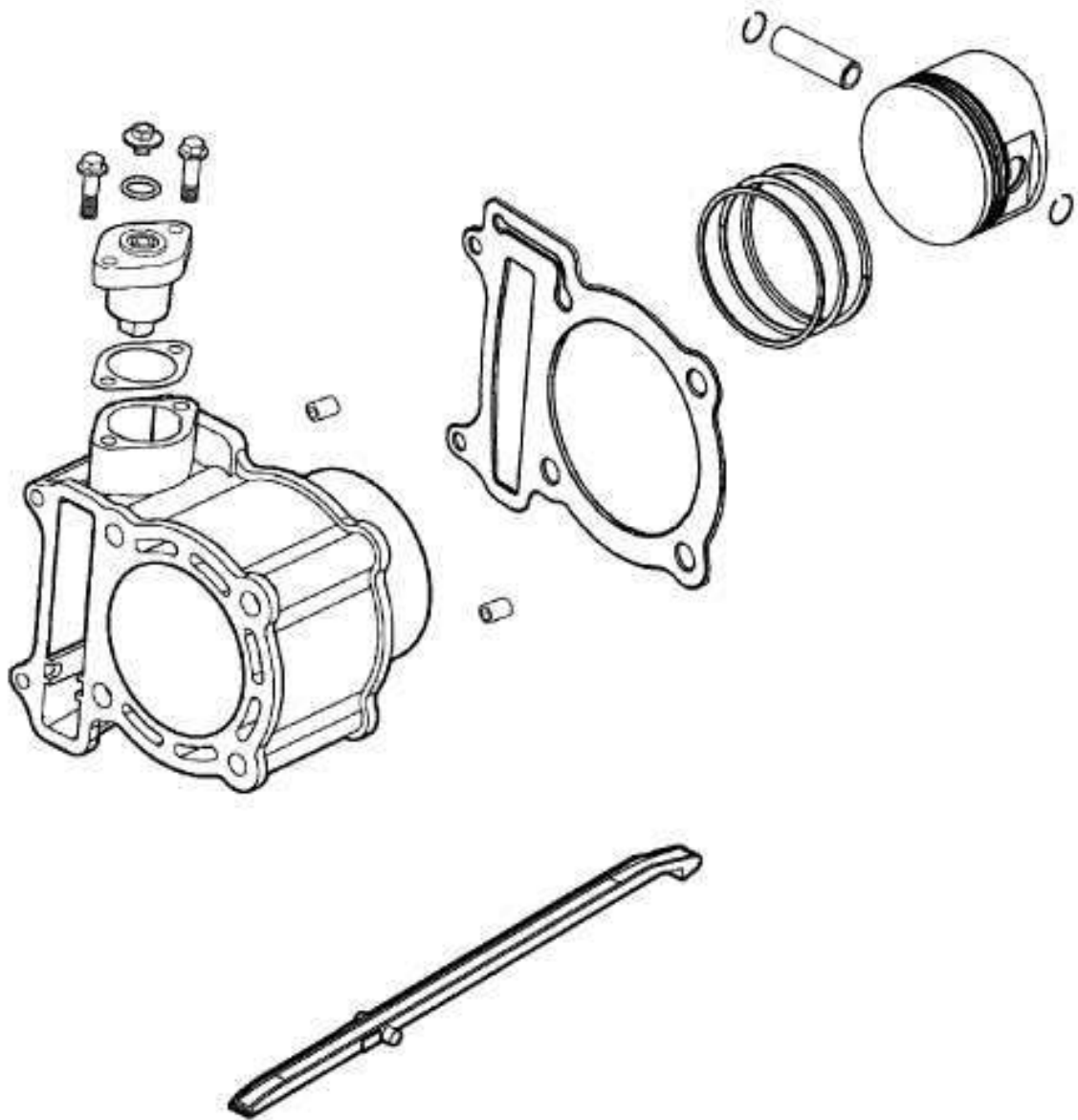

SERVICE INFORMATION

GENERAL INSTRUCTIONS

- The cylinder and piston can be serviced with the engine installed in the frame.
- When installing the cylinder, use a new cylinder gasket and make sure that the dowel pins are correctly installed.
- After disassembly, clean the removed parts and dry them with compressed air before inspection.

SPECIFICATIONS

Item		Standard (mm)	Service Limit (mm)
Cylinder	I.D.	72.705~72.715	72.80
	Flat surface	0.01	0.05
	Cylindricity	0.01	0.05
	True roundness	0.01	0.05
Piston, piston ring	Ring-to-groove clearance	top	0.02
		Second	0.015~0.050
	Ring end gap	top	0.1~0.25
		Second	0.15~0.30
		Oil side rail	0.25~0.7
	Piston O.D.	72.67~72.69	72.6
	Piston O.D. measuring position	9mm from bottom of skirt	9mm from bottom of skirt
	Piston-to-cylinder clearance	0.010~0.040	0.1
Piston pin hole I.D.	17.002~17.008	17.04	
Piston pin O.D		16.994~17.000	16.96
Piston-to-piston pin clearance		0.002~0.014	0.02
Connecting rod small end I.D. bore		17.016~17.034	17.06

TROUBLESHOOTING

- When hard starting or poor performance at low speed occurs, check the crankcase breather for white smoke. If white smoke is found, it means that the piston rings are worn, stuck or broken.

Compression too low or uneven compression

- Worn or damaged cylinder and piston rings
- Worn, stuck or broken piston rings

Compression too high

- Excessive carbon build-up in combustion chamber or on piston head

Excessive smoke from exhaust muffler

- Worn or damaged piston rings
- Worn or damaged cylinder and piston

Abnormal noisy piston

- Worn cylinder, piston and piston rings
- Worn piston pin hole and piston pin
- Incorrectly installed piston

7. CYLINDER/PISTON

LIKE 200i

CYLINDER REMOVAL

Remove the cylinder head.
Remove the dowel pins and cylinder head gasket.
Remove the water hose from the cylinder.

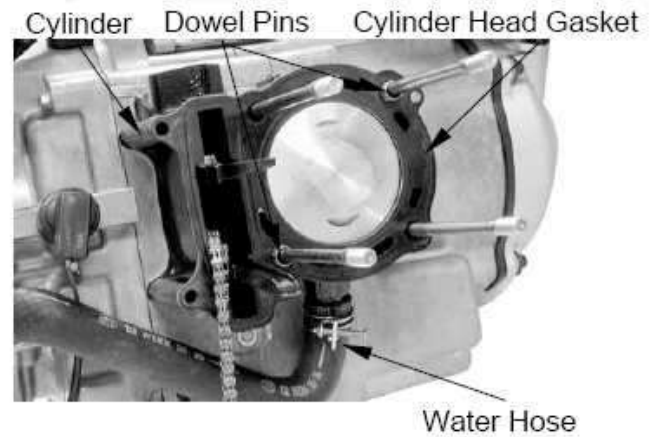

Remove the cam chain guide.
Remove the cylinder.

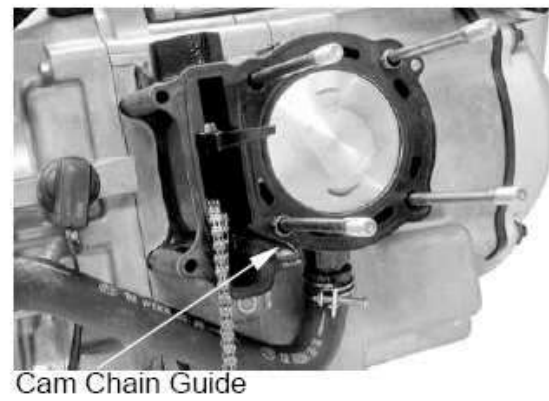

Remove the cylinder gasket and dowel pins.
Clean any gasket material from the cylinder surface.

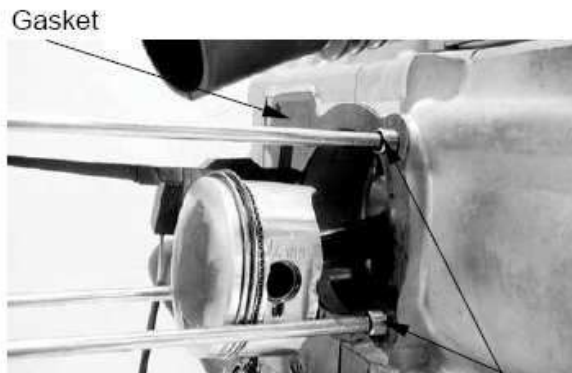

PISTON REMOVAL

Remove the piston pin clip.
Press the piston pin out of the piston.

* Place a clean towel in the crankcase to keep the piston pin clip from falling into the crankcase.

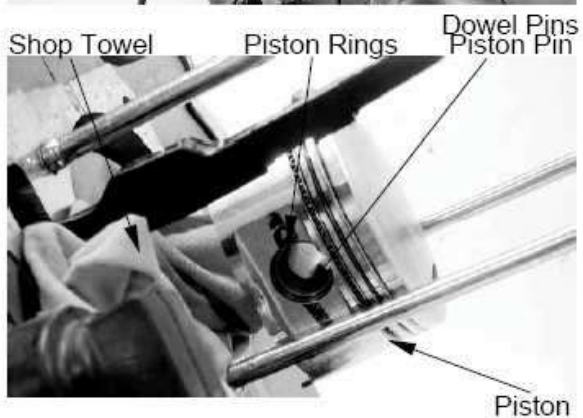

7. CYLINDER/PISTON

LIKE 200i

Inspect the piston, piston pin and piston rings.

Remove the piston rings.

- * Take care not to damage or break the piston rings during removal.

Clean carbon deposits from the piston ring grooves.



Install the piston rings onto the piston and measure the piston ring-to-groove clearance.

Service Limits:

Top: 0.09 mm replace if over

2nd: 0.09 mm replace if over



Remove the piston rings and insert each piston ring into the cylinder bottom.

- * Use the piston head to push each piston ring into the cylinder.

Measure the piston ring end gap.

Service Limit: 0.5mm replace if over



Measure the hole I.D. of piston pin

Service Limit: 17.04 mm replace if over



Measure the piston pin O.D.

Service Limit: 16.96 mm replace if below



Measure the piston O.D.

- * • Take measurement at 9mm from the bottom and 90° to the piston pin hole.

Service Limit: 72.60mm replace if below

Measure the piston-to-piston pin clearance.

Service Limit: 0.02mm replace if over



CYLINDER INSPECTION

Inspect the cylinder bore for wear or damage. Measure the cylinder I.D. at three levels of top, middle and bottom at 90° to the piston pin (in both X and Y directions).

Service Limit:
72.80 mm repair or replace if over

Measure the cylinder-to-piston clearance.

Service Limit:
0.1 mm repair or replace if over



The true roundness is the difference between the values measured in X and Y directions. The cylindricity (difference between the values measured at the three levels) is subject to the maximum value calculated.

Service Limits:
True Roundness:
0.09mm repair or replace if over
Cylindricity: 0.09 mm repair or replace if over

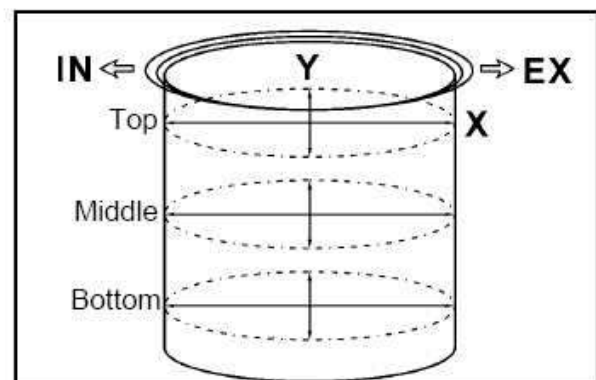

7. CYLINDER/PISTON

LIKE 200i

Inspect the top of the cylinder for flat surface.

Service Limit: 0.05 mm repair or replace if over

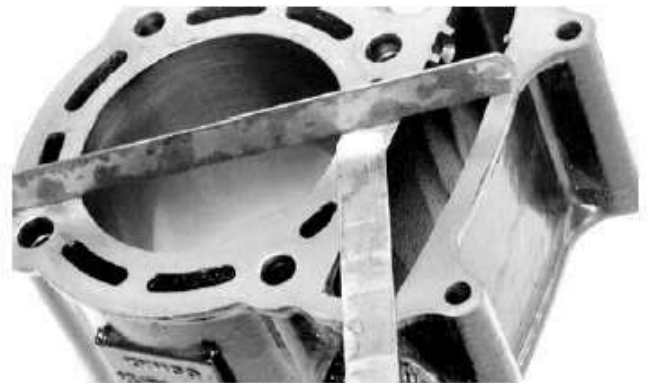

Measure the connecting rod small end I.D.

Service Limit: 17.06 mm replace if over

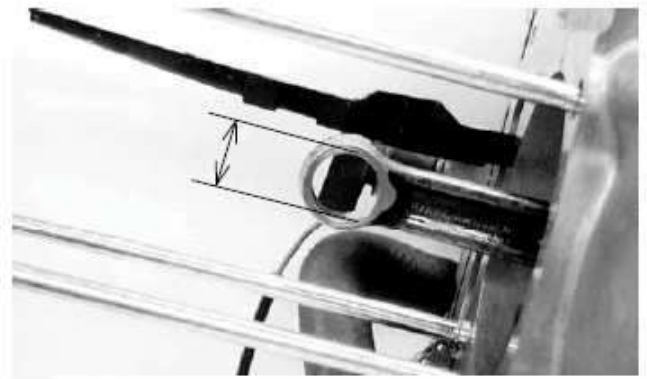

PISTON RING INSTALLATION

Install the piston rings onto the piston.
Apply engine oil to each piston ring.

- *
- Be careful not to damage the piston and piston rings during assembly.
 - All rings should be installed with the markings facing up.
 - After installing the rings, they should rotate freely without sticking.
 - Stagger the ring end gaps as the figure shown.

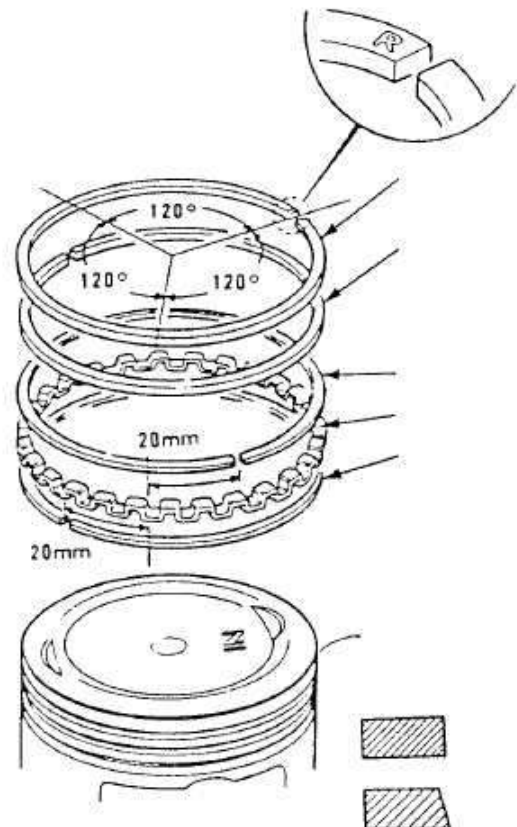

PISTON INSTALLATION

Remove any gasket material from the crankcase surface.

- * Be careful not to drop foreign matters into the crankcase.



Install the piston, piston pin and a new piston pin clip.

- * Position the piston "IN" mark on the intake valve side.
- * Place a clean towel in the crankcase to keep the piston pin clip from falling into the crankcase.

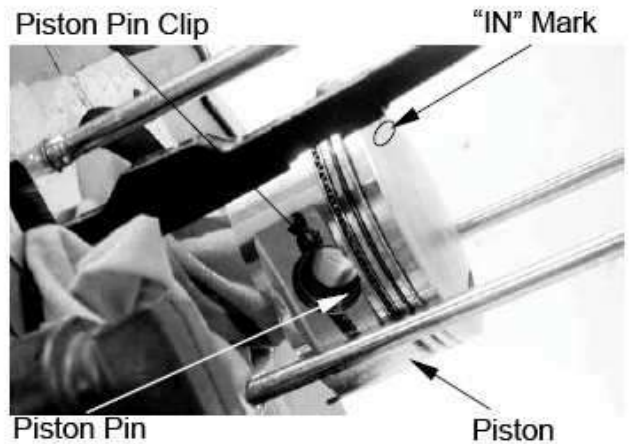

CYLINDER INSTALLATION

Install the dowel pins and a new cylinder gasket on the crankcase.

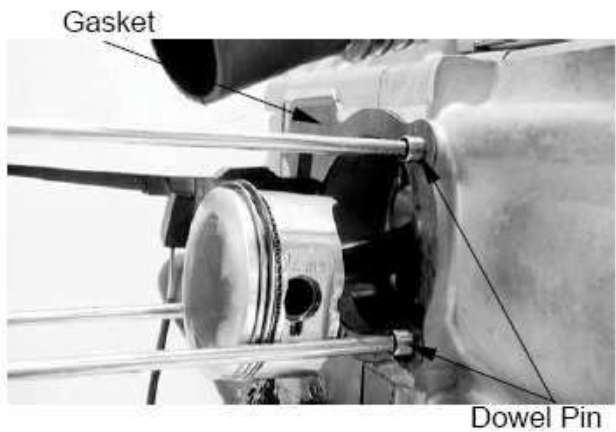

Coat the cylinder bore, piston and piston rings with clean engine oil. Carefully lower the cylinder over the piston by compressing the piston rings.

- * Be careful not to damage or break the piston rings.
- * The piston ring end gaps should not be parallel with or at 90° to the piston pin.

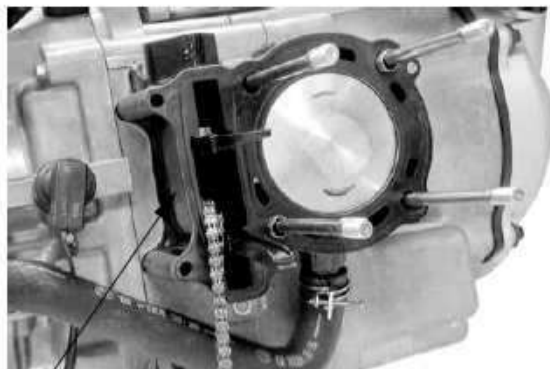

7. CYLINDER/PISTON

LIKE 200i

Install the cam chain guide.

- * Insert the tab on the cam chain guide into the cylinder groove.



Cam Chain Guide

Install the cylinder head gasket and dowel pins.
Connect the water hose to the cylinder.

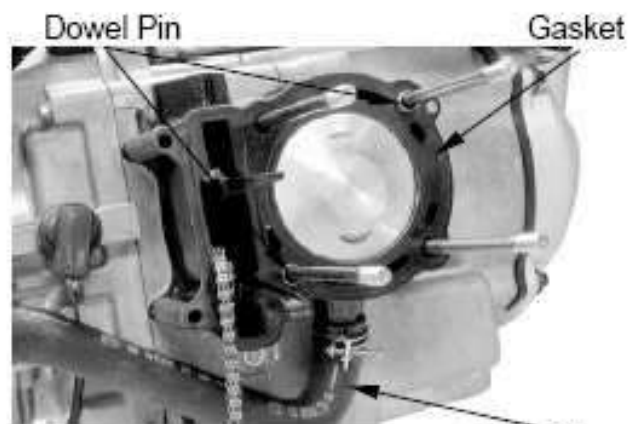

Dowel Pin

Gasket

Water Hose

Install the cylinder head.
Tighten the cylinder base bolt.

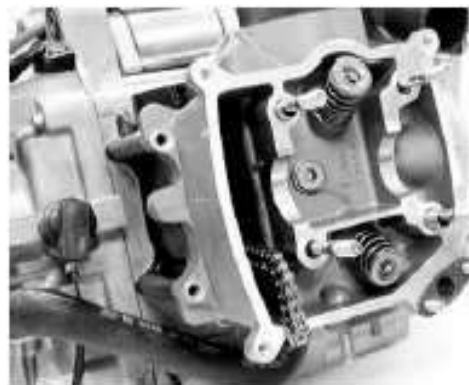

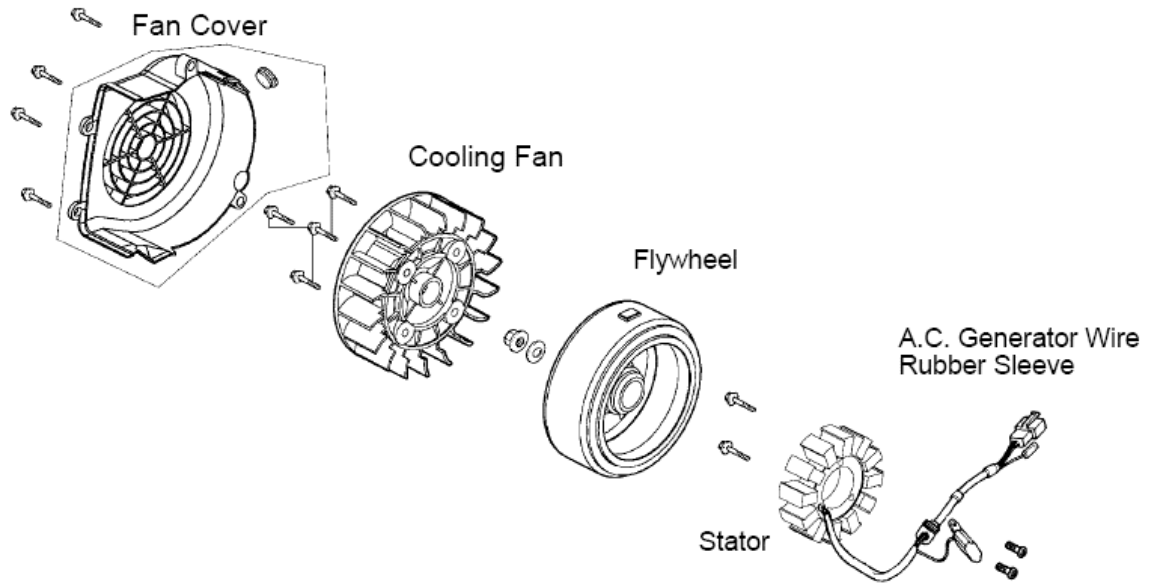

SERVICE INFORMATION

GENERAL INSTRUCTIONS

- A.C. generator maintenance and inspection can be made with the engine installed.
- Refer to Section 15 for A.C. generator inspection.

TORQUE VALUE

Flywheel nut : 3.5~4.0kgf-m (35~40 N-m)

SPECIAL TOOLS

Flywheel puller	A120E00002
Universal holder	A120E00017

A.C. GENERATOR

REMOVAL

Remove the rear right side cover.
Remove the four bolts attaching the cooling fan cover to remove the fan cover.
Remove the cooling fan by removing the cooling fan attaching four bolts.

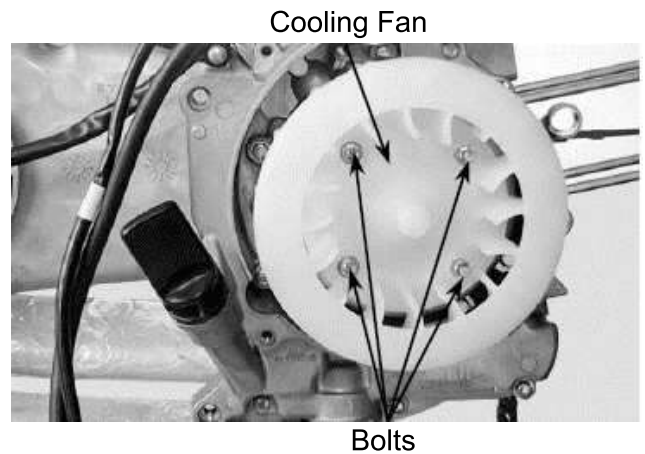

Hold the flywheel with the universal holder.
Remove the flywheel nut.

SPECIAL TOOLS

Universal holder A120E00017

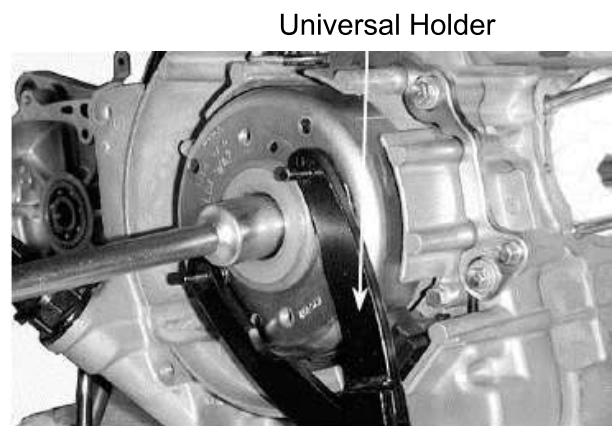

Remove the A.C. generator flywheel using the flywheel puller.
Remove the woodruff key.

SPECIAL TOOLS

Flywheel Puller A120E00002

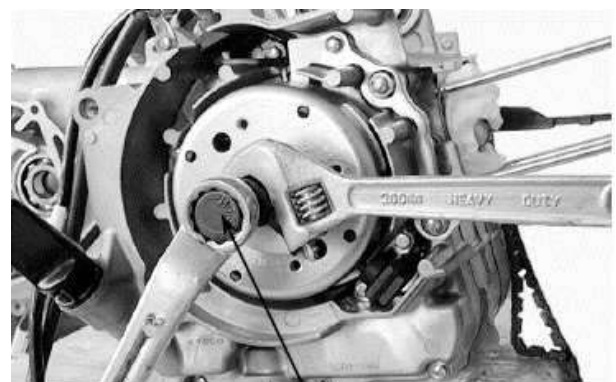

Remove the A.C. generator wire connector.

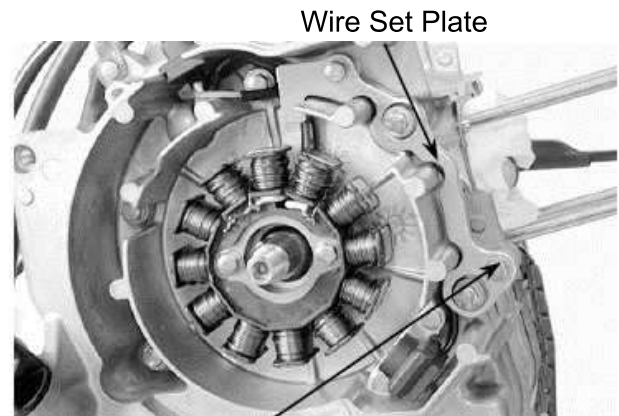

Wire Set Plate

Remove the A.C. generator wire set plate.
Remove the pulser coil bolts.
Remove the A.C. generator wire rubber sleeve and Crankshaft Position Sensor from the right crankcase.
Remove the two bolts and A.C. generator stator.

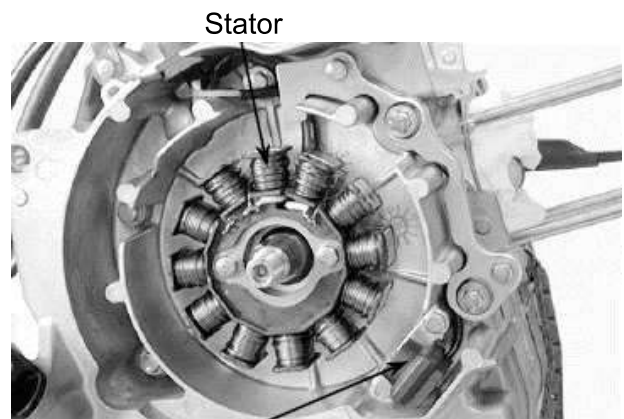

Stator

Bolts

INSTALLATION

Install the A.C. generator stator and Crankshaft Position Sensor onto the right crankcase.
Tighten the stator and CPS bolts.

Torques: CPS 0.5kg-m
 Stator 0.9kg-m

Install the A.C. generator wire rubber sleeve and A.C. generator wire set plate.

Connect the A.C. generator wire connector.
Clean the taper hole in the flywheel off any burrs and dirt.
Install the woodruff key in the crankshaft keyway.



CPS Set Plate

8. A.C. GENERATOR

LIKE 200i

Install the flywheel onto the crankshaft with the flywheel hole aligned with the crankshaft woodruff key.

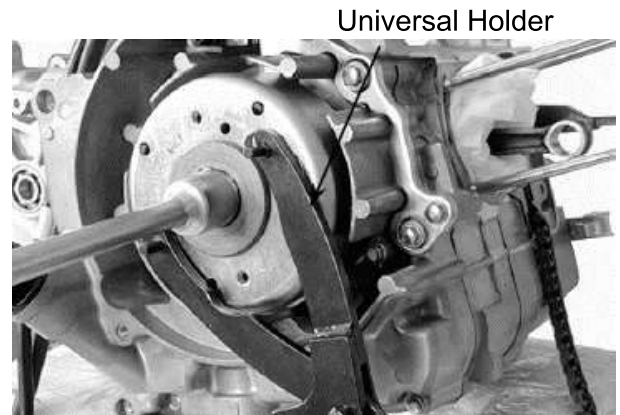

Install the cooling fan.

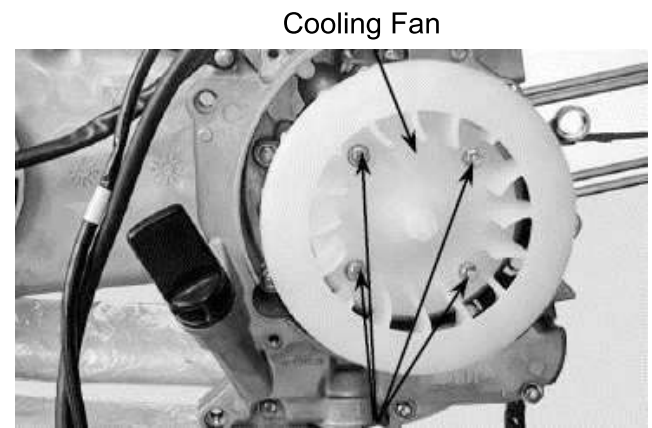

Bolts

Install the fan cover.
Install the rear right side cover.

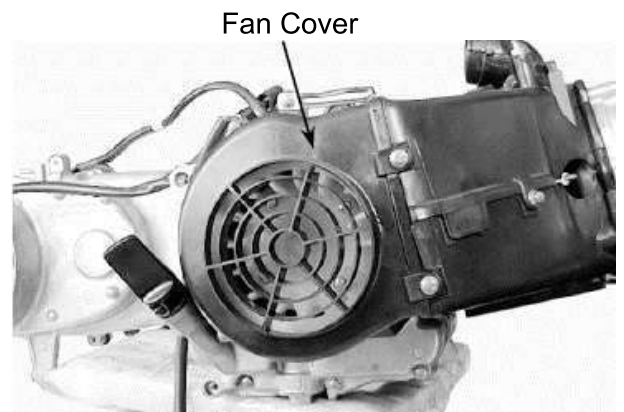

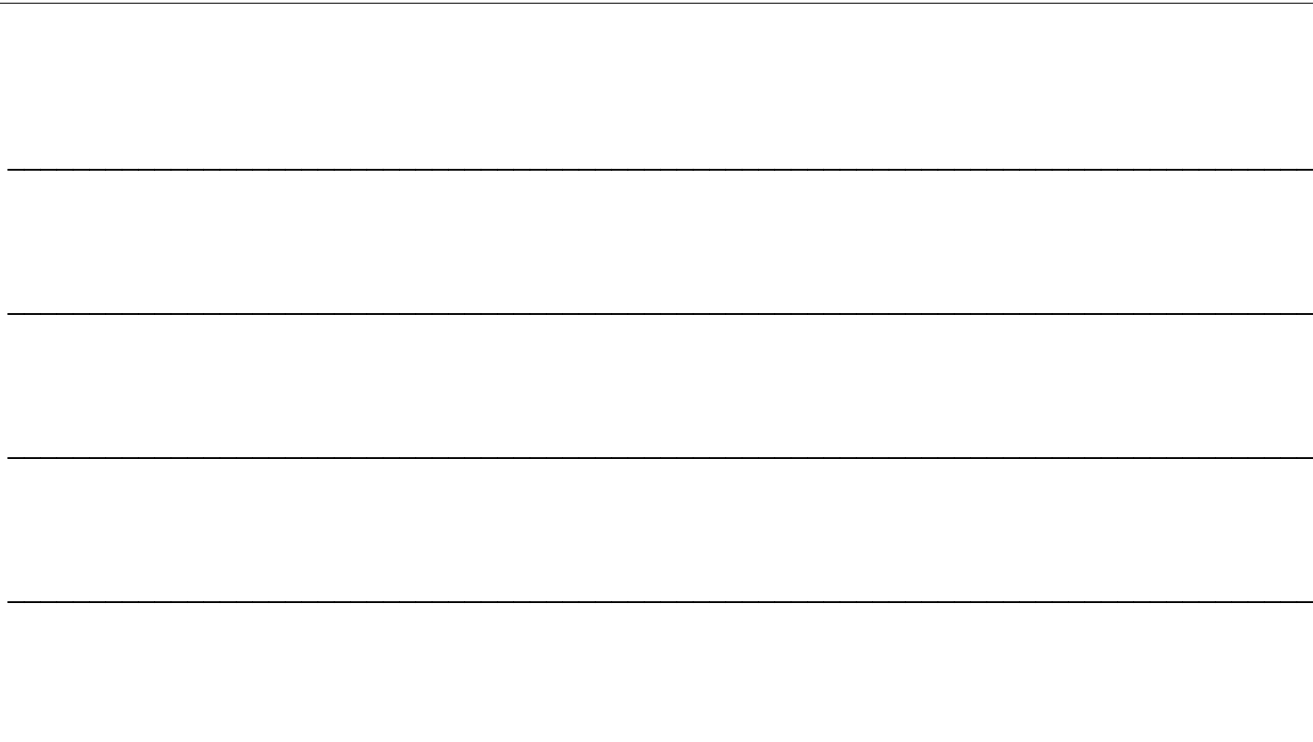

DRIVE AND DRIVEN PULLEYS/V-BELT

SCHEMATIC DRAWING-----	9- 1
SERVICE INFORMATION-----	9- 2
TROUBLESHOOTING -----	9- 2
LEFT CRANKCASE COVER -----	9- 3
DRIVE PULLEY -----	9- 4
CLUTCH OUTER/DRIVEN PULLEY/V-BELT -----	9- 4

SCHEMATIC DRAWING

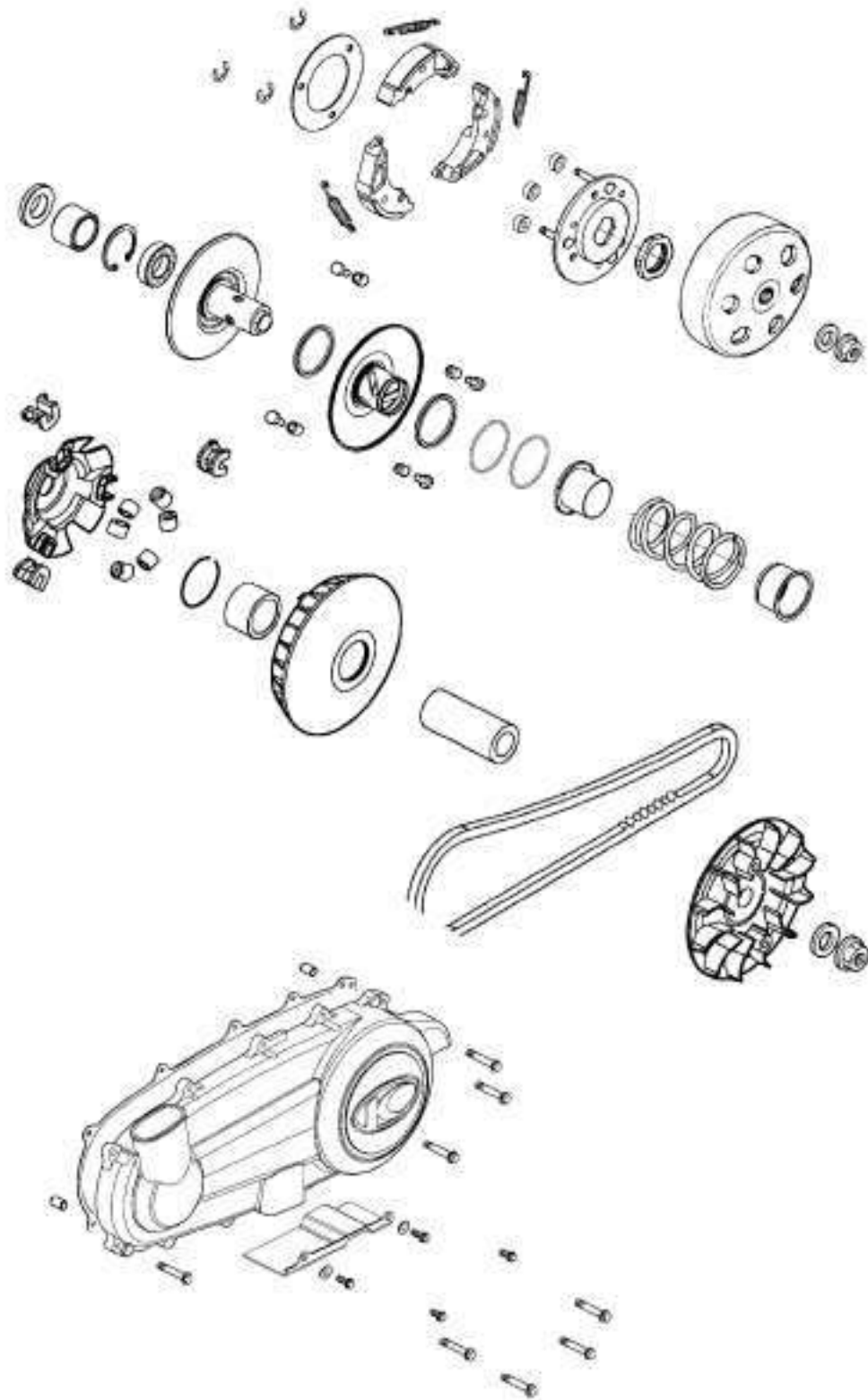

SERVICE INFORMATION

GENERAL INSTRUCTIONS

- The drive pulley, clutch and driven pulley can be serviced with the engine installed.
- Avoid getting grease and oil on the drive belt and pulley faces. Remove any oil or grease from them to minimize the slipping of drive belt and drive pulley.

SPECIFICATIONS

Item	Standard (mm)	Service Limit (mm)
Movable driven face bushing I.D.	40.000 ~ 40.025	40.06
Driven face collar O.D.	39.965 ~ 39.955	39.85
Clutch lining thickness	3.963 ~ 4.037	2.0
Clutch outer I.D.	153.0 ~ 153.2	153.5
Weight roller O.D	22.92 ~ 23.08	22.0
Drive pulley collar O.D.	26.960 ~ 26.974	26.90

TORQUE VALUES

- Drive face nut 93.1 N-m
- Clutch outer nut 54 N-m
- Clutch drive plate nut 54 N-m

SPECIAL TOOLS

- Universal holder E017
- Clutch spring compressor E034

TROUBLESHOOTING

Engine starts but motorcycle won't move

- Worn drive belt
- Broken ramp plate
- Worn or damaged clutch lining
- Broken driven face spring

Lack of power

- Worn drive belt
- Weak driven face spring
- Worn weight roller
- Faulty driven face

Engine stalls or motorcycle creeps

- Broken clutch weight spring

LEFT CRANKCASE COVER REMOVAL

Remove the met-in box and carrier.
Remove the body cover, center cover and rear fender A together.
Disconnect the belt air tube from the frame.

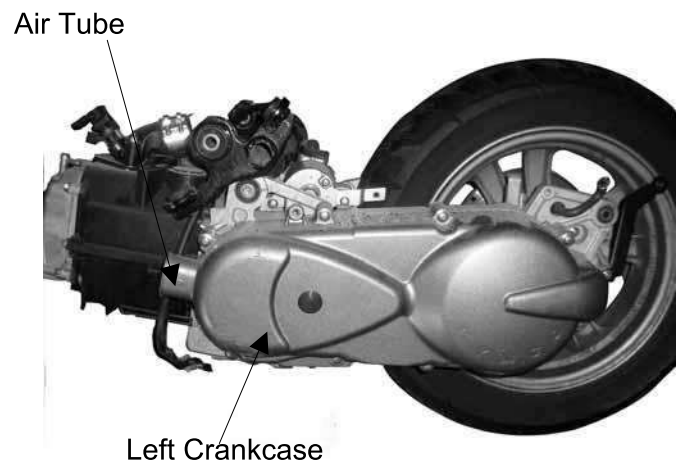

Remove the left crankcase cover bolts and left crankcase covers.
Remove the seal rubber and dowel pins.

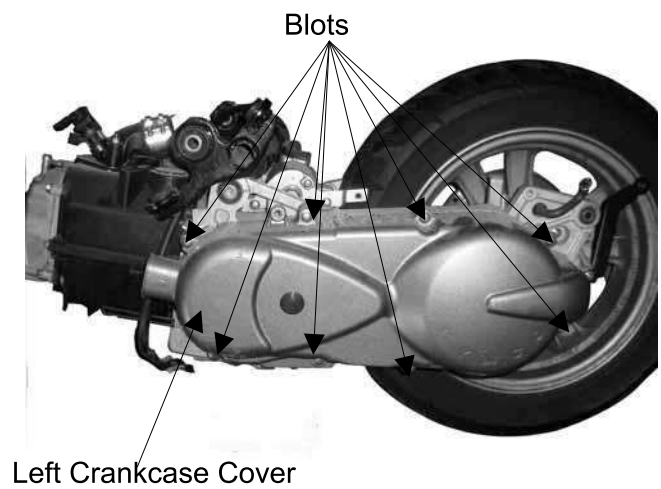

INSTALLATION

Install the dowel pins and the seal rubber.

Install the left crankcase cover.
Install and tighten the left crankcase cover bolts.

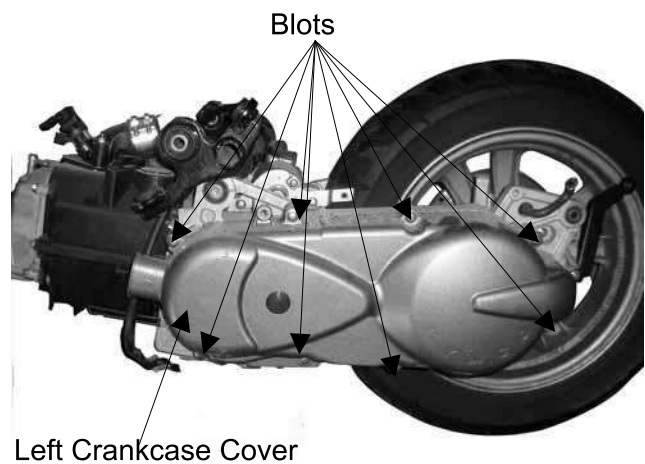

Connect the drive belt air tube to frame.

Air Tube

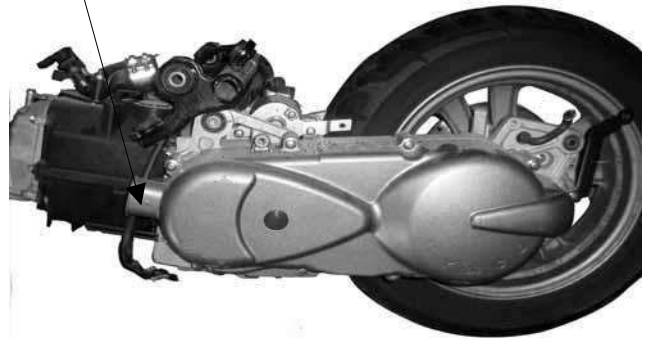

DRIVE PULLEY

DRIVE PULLEY FACE REMOVAL

Remove the left crankcase cover. (⇒8-3)
 Hold the drive pulley using a universal holder and remove the drive face nut and washer.
 Remove the drive pulley face.

Special

Universal HolderE017

Drive Pulley Face

Universal Holder



CLUTCH OUTER/DRIVEN PULLEY/V-BELT REMOVAL

Remove the left crankcase cover. (⇒8-3)
 Remove the drive pulley face. (⇒8-4)
 Hold the clutch outer with the universal holder and remove the clutch outer nut and washer.

Special

Universal HolderE017

Remove the clutch outer, driven pulley and belt together.

Remove the drive belt from the movable drive face.

Movable Drive Face



Drive Belt

INSPECTION

Check the drive belt for cracks, separation or abnormal or excessive wear.

Replace a new belt at every 10,000km.

* •Use specified genuine parts for replacement.

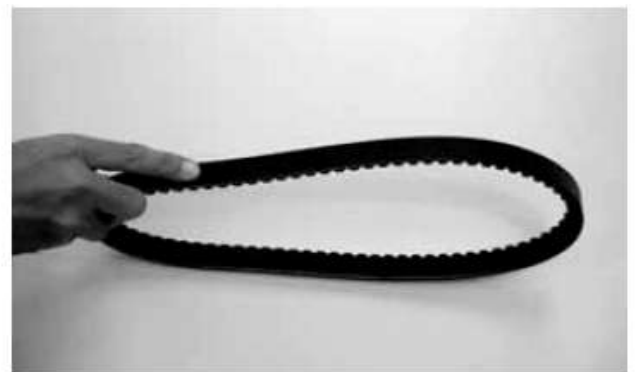

MOVABLE DRIVE FACE ASSEMBLY

Remove the pulley face, clutch outer, driven pulley and belt. (⇒8-4)
Remove the movable drive face assembly.
Remove the drive pulley collar.

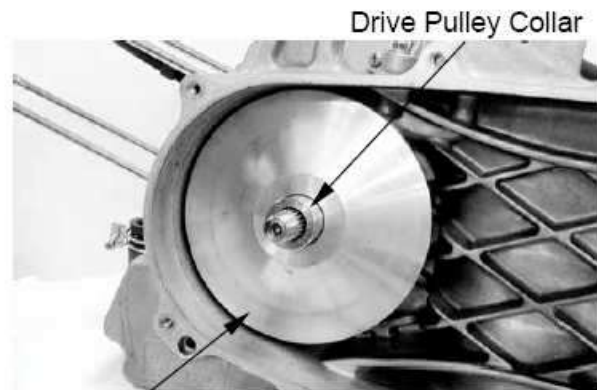

Movable Drive Face Assembly

DISASSEMBLY

Remove the ramp plate.

Ramp Plate



Remove the weight rollers.

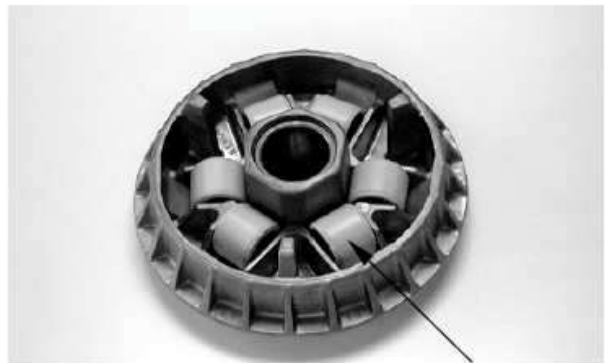

Weight Roller

INSPECTION

Check each weight roller for wear or damage.
Measure each weight roller O.D.

Service Limit: 22.00 mm replace if below

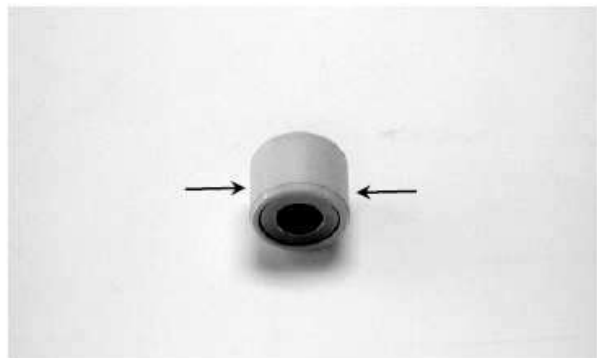

Measure the movable drive face bushing assembly I.D.

Service Limit: 27.13 mm replace if over



Check the drive pulley collar for wear or damage.
Measure the O.D. of the drive pulley collar sliding surface.

Service Limit: 26.90mm replace if below



ASSEMBLY

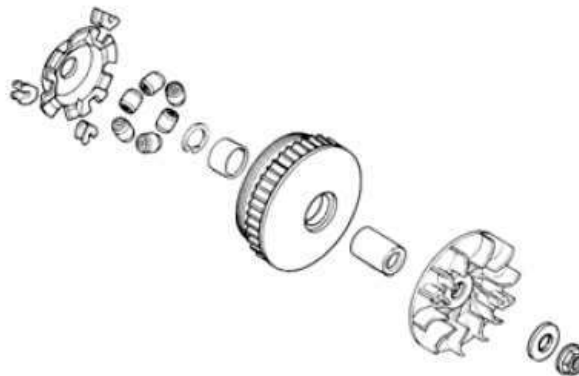

Install the weight rollers into the movable drive face.

- * The direction of all weight rolls is same. The color side is towards to clockwise.



Weight Roller

Install the ramp plate.



Insert the drive pulley collar into the movable drive face.

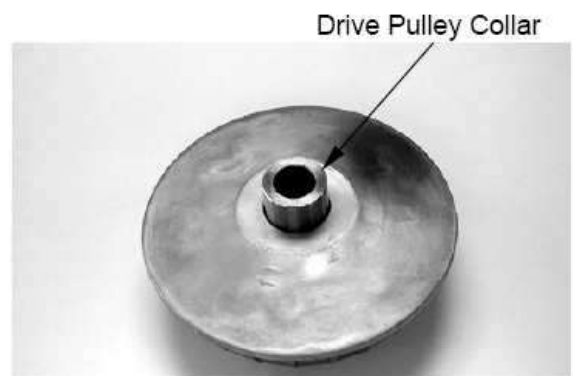

INSPECTION

Inspect the clutch outer for wear or damage.
Measure the clutch outer I.D.

Service Limit: 153.5 mm replace if over



Check the clutch shoes for wear or damage.
 Measure the clutch lining thickness.
Service Limit: 2.0 mm replace if below

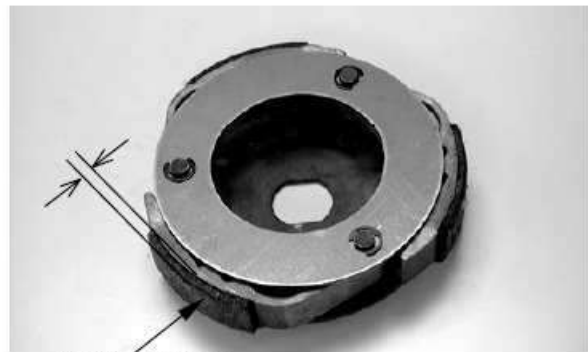

Clutch Lining

**CLUTCH/DRIVEN PULLEY
 DISASSEMBLY**



Clutch/Driven Pulley

Hold the clutch/driven pulley assembly with the clutch spring compressor.

- * Be sure to use a clutch spring compressor to avoid spring damage.

Special

Clutch Spring Compressor E034
 Set the tool in a vise and remove the clutch drive plate nut.
 Lock Nut Wrench, 39mm



Loosen the clutch spring compressor and disassemble the clutch/driven pulley assembly.
 Remove the seal collar.

Pull out the guide roller pins and guide rollers. Remove the movable driven face from the driven face.

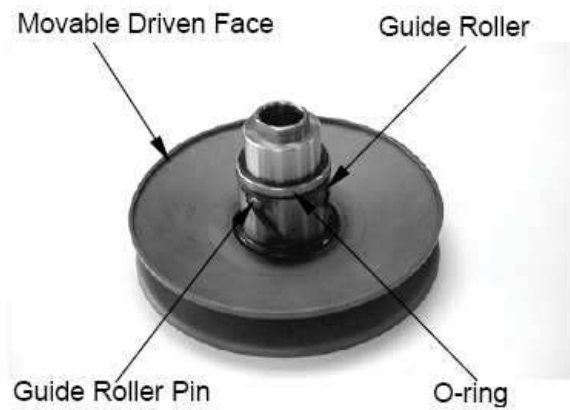

Remove the oil seal from the movable driven face.

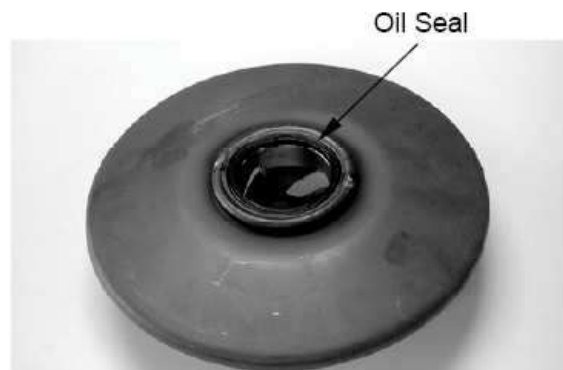

INSPECTION

Measure the driven face spring free length.
Service Limit: 130.5 mm replace if below

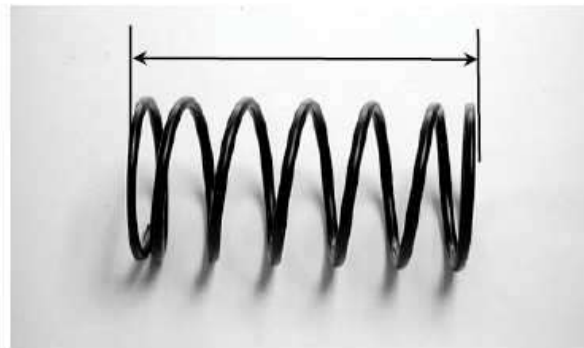

Check the driven face assembly for wear or damage.
 Measure the driven face O.D.
Service Limit: 39.85 mm replace if below



Check the movable driven face for wear or damage.
 Measure the movable driven face I.D.
Service Limit: 40.06mm replace if over

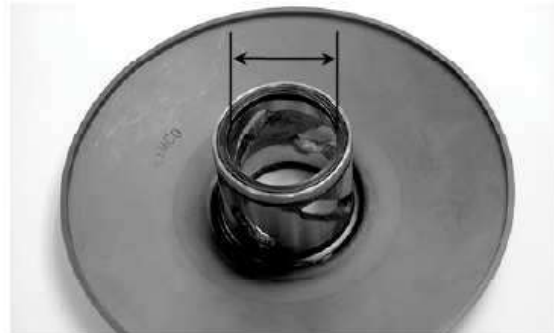

DRIVEN PULLEY FACE BEARING REPLACEMENT

Check the bearings for play and replace them if they have excessive play.
 Drive the inner needle bearing out of the driven pulley face.

- * Discard the removed bearing and replace with a new one.

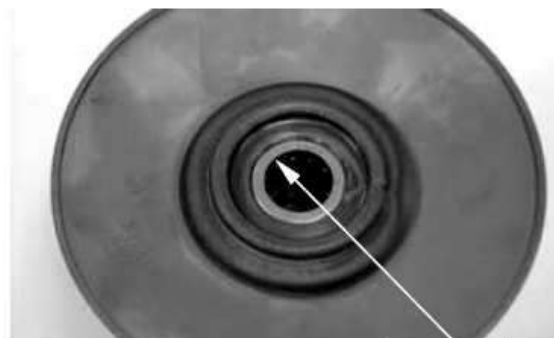

Inner Bearing

Remove the snap ring and drive the outer bearing out of the driven face.

- * Discard the removed bearing and replace with a new one.

Apply grease to the outer bearing.
 Drive a new outer bearing into the driven face with the sealed end facing up.

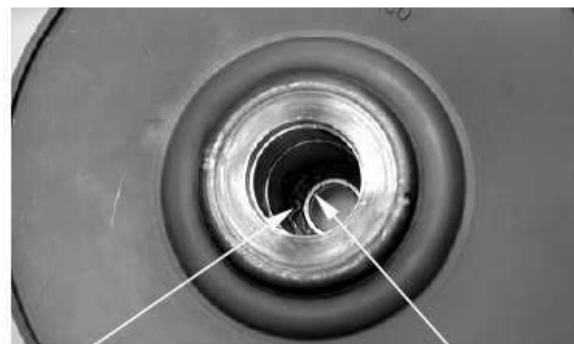

Snap Ring

Outer Bearing

Seat the snap ring in its groove.
 Apply grease to the driven face bore areas.

- * Pack all bearing cavities with 9~9.5g grease.

Press a new needle bearing into the driven face.

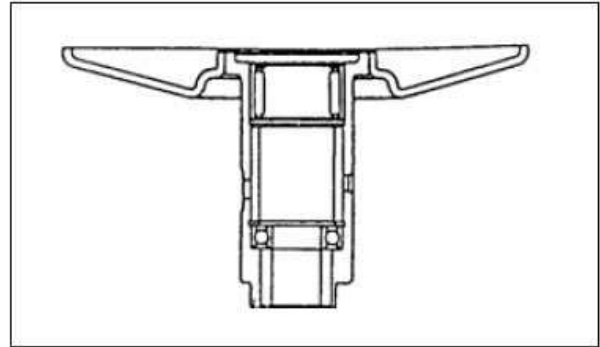

CLUTCH DISASSEMBLY

Remove the clips and retainer plate to disassemble the clutch.

* • Keep grease off the clutch linings.

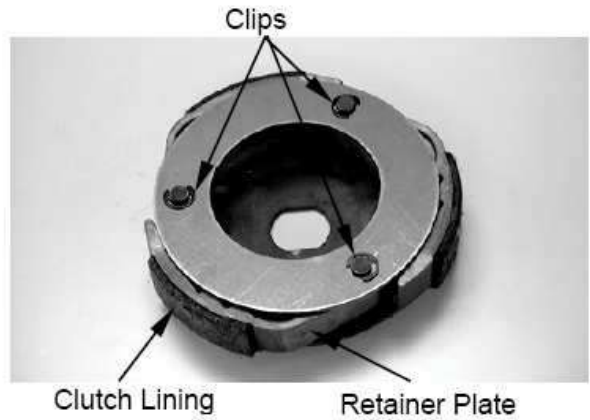

CLUTCH ASSEMBLY

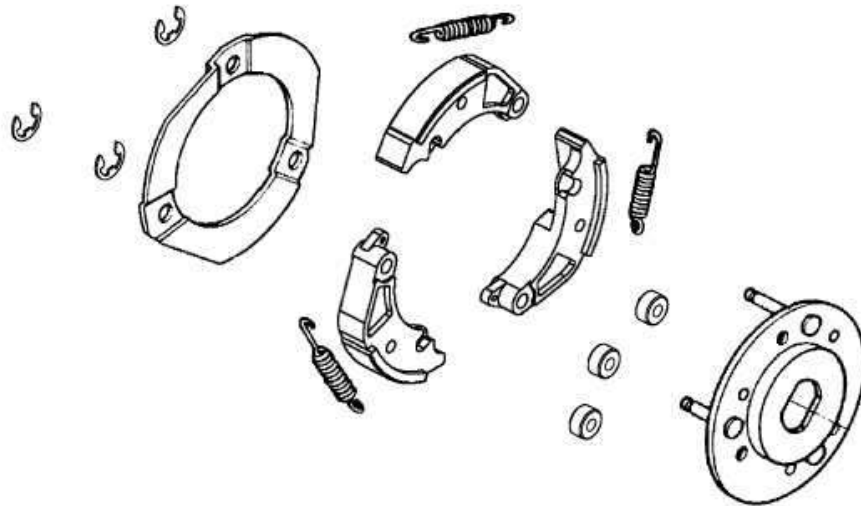

Install the damper rubbers on the drive plate pins.
 Install the clutch weights/shoes and clutch springs onto the drive plate.
 Install the retainer plate and secure with the clips.

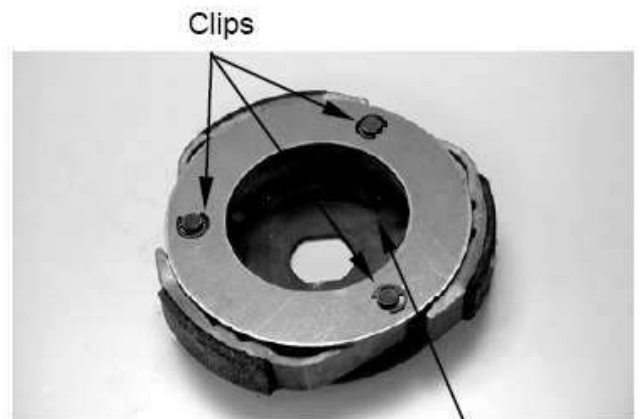

Clips
 Drive Plate
 Movable Driven Face

CLUTCH / DRIVEN PULLEY ASSEMBLY

Clean the pulley faces and remove any grease from them.
 Apply grease to the O-rings and install them onto the moveable driven face.

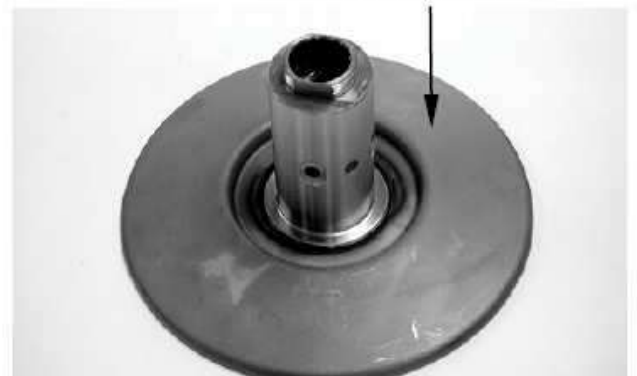

Install the movable driven face onto the driven face.
 Apply grease to the guide rollers and guide roller pins and then install them into the holes of the driven face.

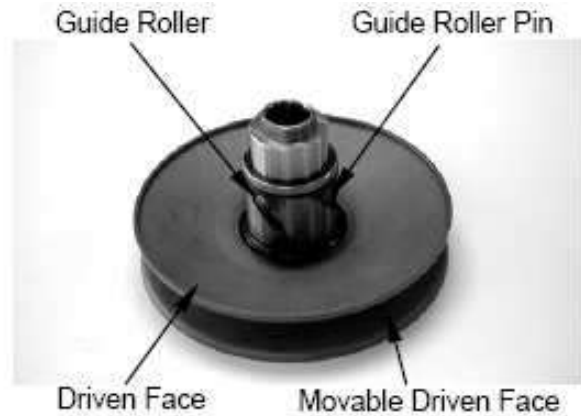

Install the seal collar.
 Remove any excessive grease.

- * Be sure to clean the driven face off any grease.



Set the driven pulley assembly, driven face spring and clutch assembly onto the clutch spring compressor.

- * Align the flat surface of the driven face with the flat on the clutch drive plate.

Clutch Spring Compressor

Compress the tool and install the drive plate nut.
 Set the tool in a vise and tighten the drive plate nut to the specified torque.
Torque: 54 N-m

- * Be sure to use a clutch spring compressor to avoid spring damage.



Special

Clutch Spring CompressorE034

INSTALLATION

Install the movable drive face assembly and drive pulley collar onto the crankshaft.



Movable Drive Face Assembly

Put the drive belt on the driven pulley.
Put the drive belt on the drive pulley collar.
Install the clutch/driven pulley and clutch outer onto the drive shaft.

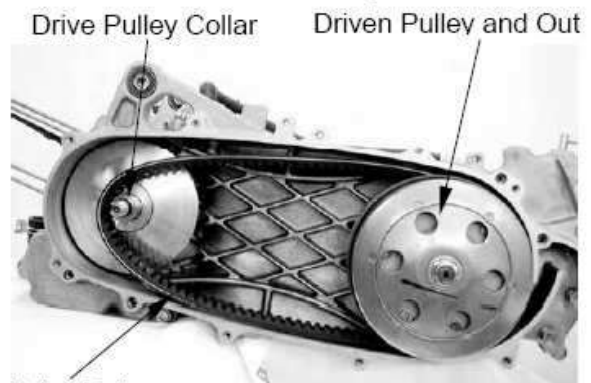

Drive Belt

- * • Keep grease off the drive shaft.

Install washer and the clutch outer nut.
Hold the clutch outer with the universal holder to tighten clutch outer nut.
Torque: 54 N-m

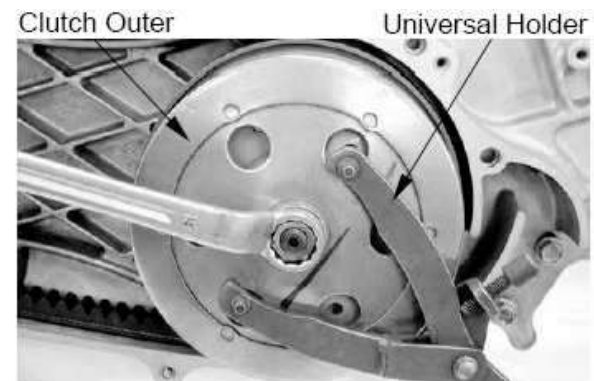

Special
Universal HolderE017

Install the drive pulley face, washer and drive face nut.
Hold the drive pulley with the universal holder and tighten the drive face nut.
Torque: 93.1 N-m

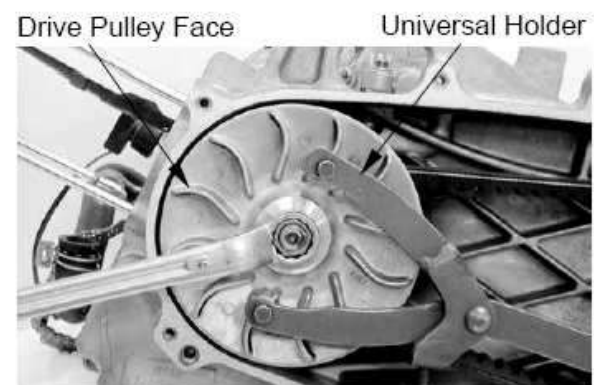

Special
Universal HolderE017

- * • Do not get oil or grease on the drive belt or drive pulley faces.

Install the left crankcase cover.

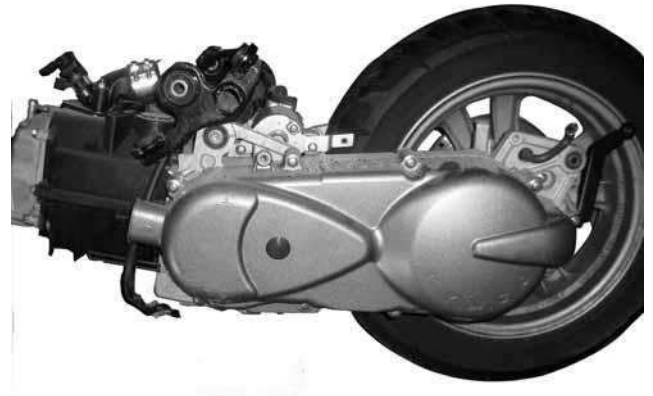

FINAL REDUCTION

SERVICE INFORMATION	10-2
TROUBLESHOOTING.....	10-2
FINAL REDUCTION DISASSEMBLY	10-3
FINAL REDUCTION INSPECTION	10-3
FINAL REDUCTION ASSEMBLY	10-5

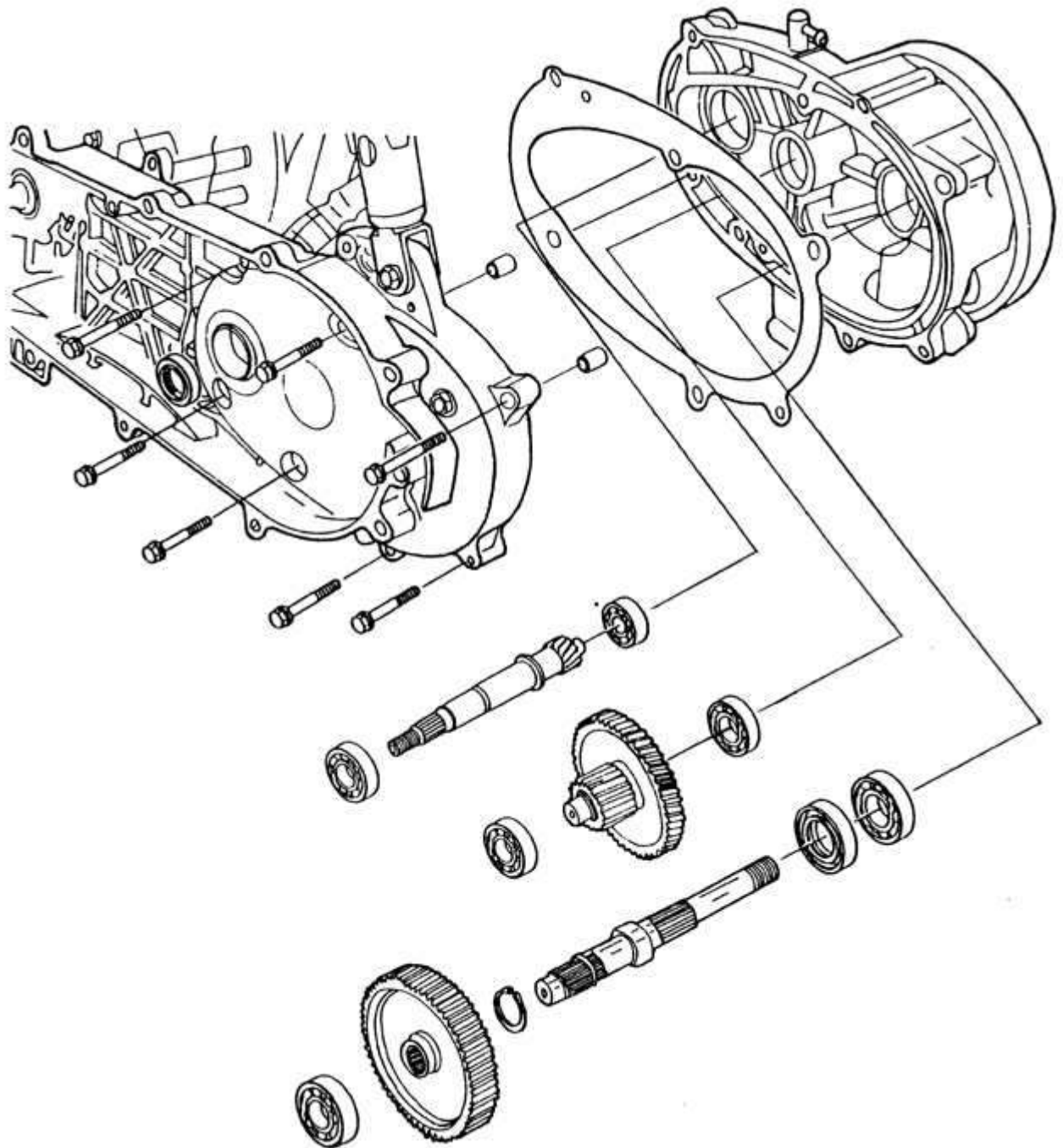

SERVICE INFORMATION GENERAL INSTRUCTIONS

- When replacing the drive shaft, use a special tool to hold the bearing inner race for this operation.

SPECIFICATIONS

Specified Oil: GEAR OIL SAE 90#

Oil Capacity: At change : 0.181 liter

At disassembly : 0.21 liter

TORQUE VALUES

Transmission case cover bolt 1.2kg-m

SPECIAL TOOLS

Driver handle A

Outer driver, 32x35mm

Outer driver, 37x40mm

Outer driver, 42x47mm

Pilot, 15mm

Pilot, 17mm

Pilot, 20mm

Crankcase assembly tool

Assembly shaft

Assembly collar

TROUBLESHOOTING

Engine starts but motorcycle won't move

- Damaged transmission
- Seized or burnt transmission

Oil leaks

- Oil level too high
- Worn or damaged oil seal

10. FINAL REDUCTION

LIKE 200i

FINAL REDUCTION DISASSEMBLY

- Remove the exhaust muffler.
- Remove the rear wheel.
- Remove the rear brake cable.
- Remove the left crankcase cover.
- Remove the clutch/driven pulley.
- Drain the transmission gear oil into a clean container.
- Remove the transmission case cover attaching bolts.
- Remove the transmission case cover.
- Remove the gasket and dowel pins.

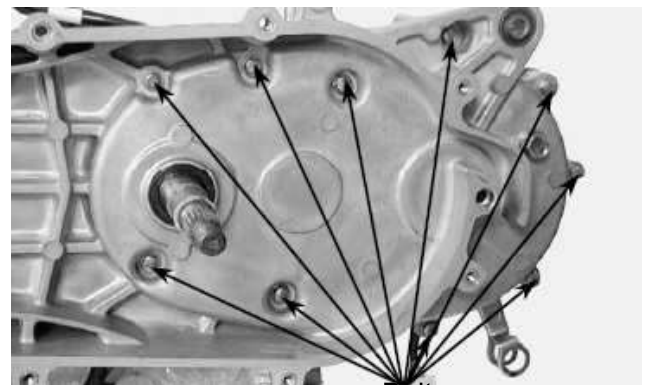

Bolts

Remove the final gear and countershaft.

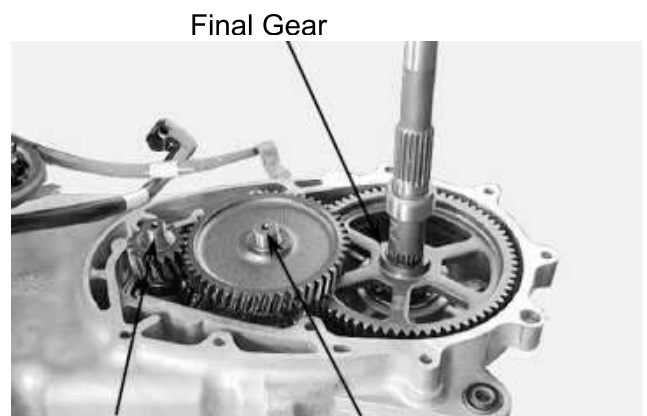

Final Gear

Drive Shaft

Countershaft

FINAL REDUCTION INSPECTION

Inspect the countershaft and gear for wear or damage.



Countershaft

Inspect the final gear and final shaft for wear, damage or seizure.



Check the left crankcase bearings for excessive play and inspect the oil seal for wear or damage.

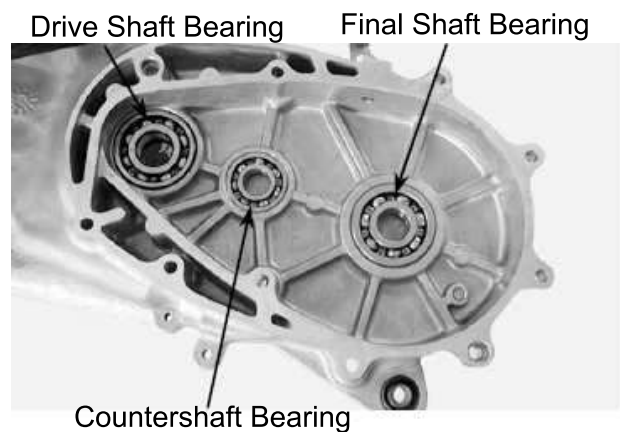

Check the transmission case cover bearings for excessive play and inspect the final shaft bearing oil seal for wear or damage.

* Do not remove the transmission case cover except for necessary part replacement. When replacing the drive shaft, also replace the bearing and oil seal.

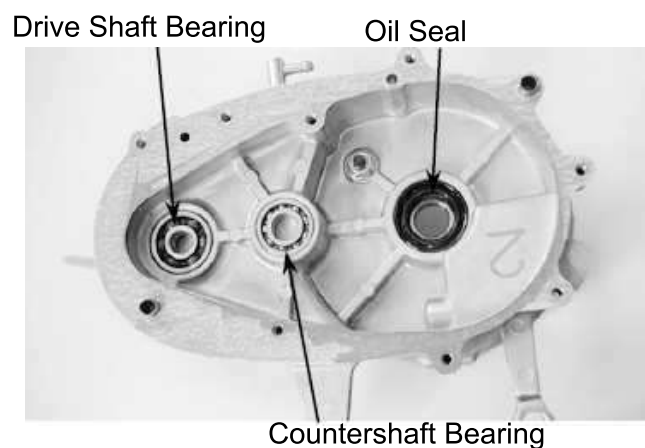

BEARING REPLACEMENT (TRANSMISSION CASE COVER)

Remove the transmission case cover bearings using a bearing remover.
Remove the final shaft oil seal.

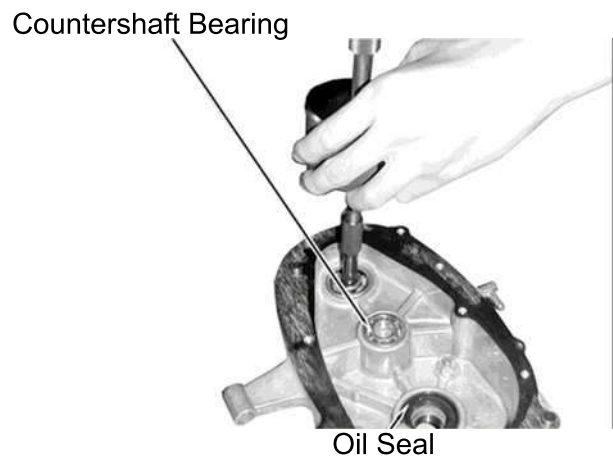

Drive new bearings into the transmission case cover.



BEARING REPLACEMENT (LEFT CRANKCASE)

Remove the drive shaft.
Remove the drive shaft oil seal.
Remove the left crankcase bearings using a bearing remover.

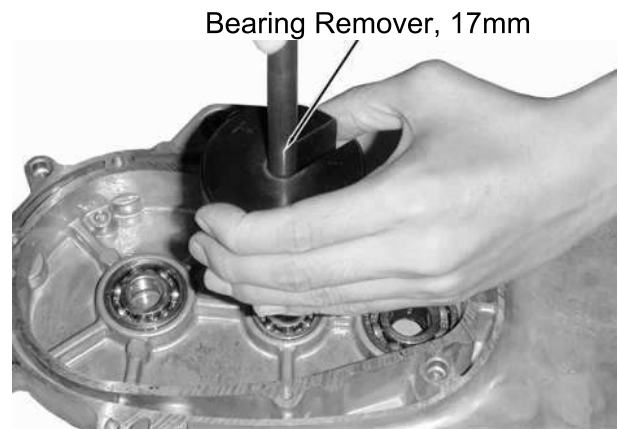

Drive new bearings into the left crankcase.

Install a new drive shaft oil seal.

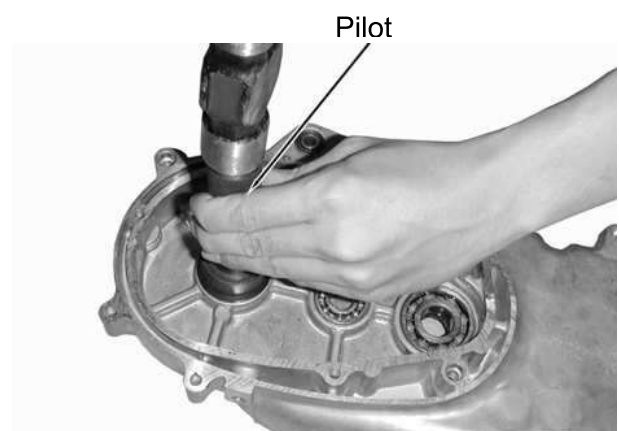

FINAL REDUCTION ASSEMBLY

Install the drive shaft into the left crankcase.
Inspect the drive shaft and gear for wear or damage.

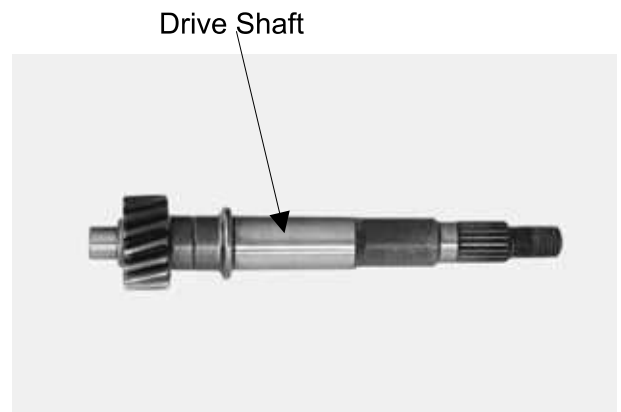

Install the final gear and final shaft into the left crankcase.
Install the countershaft and gear into the left crankcase.
Install the washer onto the countershaft.
Install the dowel pins and a new gasket.

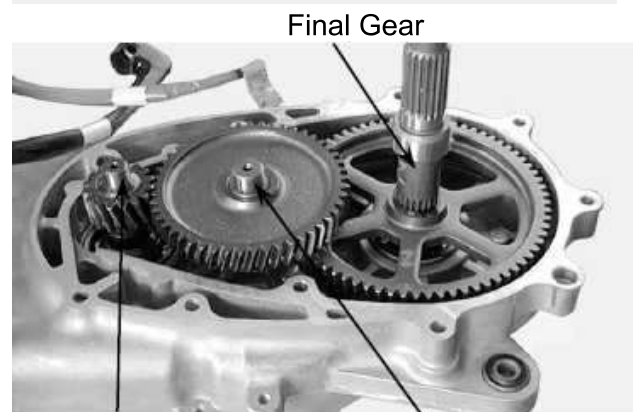

Drive Shaft

Countershaft

10. FINAL REDUCTION

LIKE 200i

Install the transmission case cover.

Transmission Case Cover

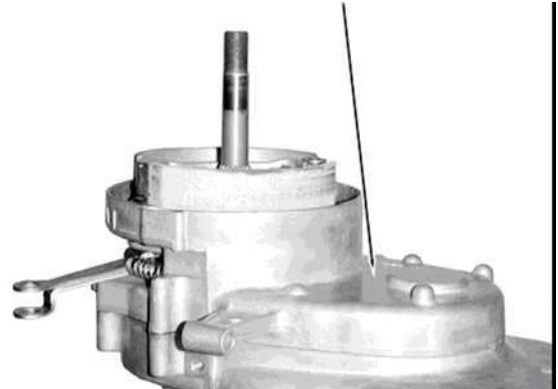

Install and tighten the transmission case cover bolts.
Install the clutch/driven pulley.
Install the rear wheel.
Install the rear brake cable.

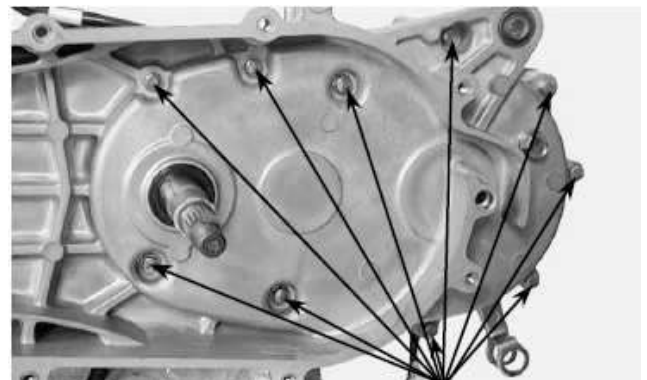

Bolts

After installation, fill the transmission case with the specified oil.

*

- Place the motorcycle on its main stand on level ground.
- Check the oil sealing washer for wear or damage.

Oil Check Bolt Hole/Oil Filler



Drain Bolt

Specified Gear Oil:
KYMCO SIGMA GEAR OIL SAE 90#

Oil Capacity:
At disassembly : 0.21 liter
At change : 0.181 liter

Install and tighten the oil check bolt.

Torque: 1.0~1.5kg-m

Start the engine and check for oil leaks.
Check the oil level from the oil check bolt hole and add the specified oil to the proper level if the oil level is low.

CRANKCASE/CRANKSHAFT

SERVICE INFORMATION	11-2
TROUBLESHOOTING.....	11-2
CRANKCASE SEPARATION	11-3
CRANKSHAFT INSPECTION	11-4
CRANKCASE ASSEMBLY	11-4

Torque: 0.8~1.2kg-m

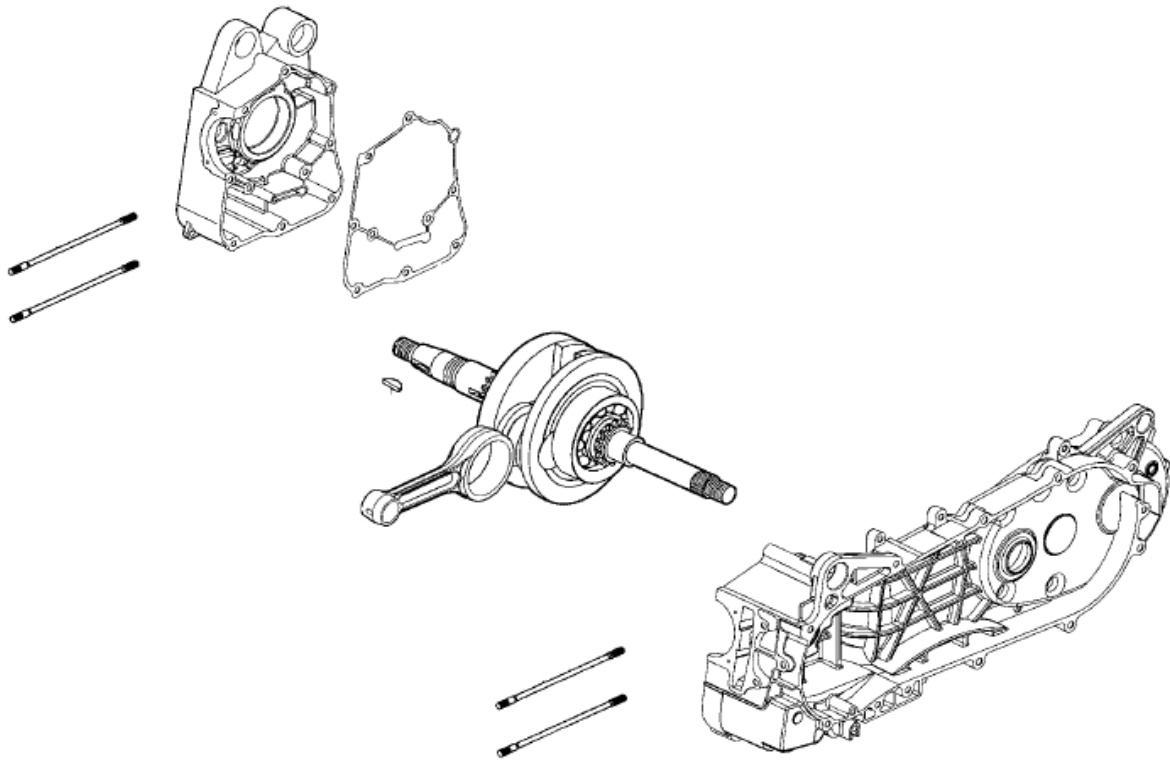

SERVICE INFORMATION

GENERAL INSTRUCTIONS

- This section covers crankcase separation to service the crankshaft.
- The following parts must be removed before separating the crankcase.

Engine (⇒Section 5)	Driven pulley (⇒Section 9)
Carburetor (⇒Section 11)	A.C. generator (⇒Section 7)
Oil pump (⇒Section 4)	Cylinder head/cylinder (⇒Section 6)
Reed valve (⇒Section 11)	
- When the left crankcase must be replaced, remove the following part in addition to the above.
 - Final reduction removal
- Special tools must be used for crankshaft and crankcase assembly. When separating the crankcase, the bearing will remain in the crankcase and it should be removed. When, assembling, drive a new bearing into the crankcase and install a new oil seal.

SPECIFICATIONS

Item	LIKE 200i	
	Standard (mm)	Service Limit (mm)
Connecting rod big end side clearance	—	0.60
Connecting rod big end radial clearance	—	0.04
Crankshaft runout	—	0.10

SPECIAL TOOLS

Crankcase puller	Bearing outer driver handle A
Universal bearing puller	Bearing outer driver, 42x47mm
Crankcase assembly collar	Bearing driver pilot, 20mm
Crankcase assembly tool	Bearing outer driver, 37x40mm
	Bearing driver pilot, 17mm

TROUBLESHOOTING

Abnormal engine noise

- Excessive crank journal bearing play
- Excessive crankpin bearing play
- Excessive transmission bearing play

11. CRANKCASE/CRANKSHAFT

LIKE 200i

CRANKCASE SEPARATION

Remove the crankcase attaching two bolts.
Separate the left and right crankcase halves.

* Do not damage the crankcase gasket surface.



Crankcase Bolts

Dowel Pins

Remove the gasket and dowel pins.



Gasket

Remove the crankshaft from the left crankcase.



Clean off all gasket material from the crankcase mating surfaces.

* Avoid damaging the crankcase mating surfaces.



11. CRANKCASE/CRANKSHAFT

LIKE 200i

Remove the oil seal from the right crankcase.
Check the oil seal lip for wear or deterioration.

The installation sequence is the reverse of removal.



CRANKSHAFT INSPECTION

Measure the connecting rod big end side clearance.

Service Limit: 0.55mm replace if over

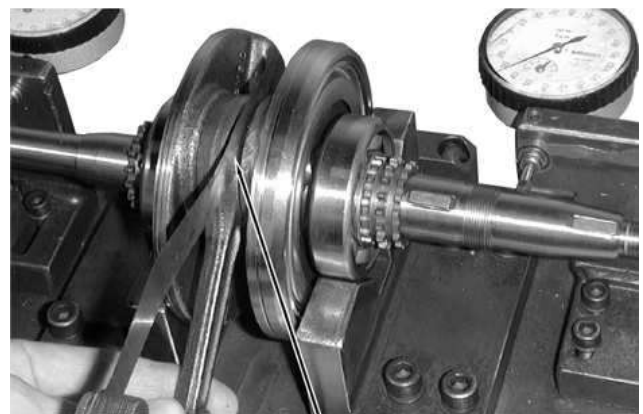

Connecting Rod Big End

Turn the crankshaft bearings and check for excessive play.

If they do not turn smoothly, quietly or if they fit loosely in the crankshaft, replace the crankshaft as a set.

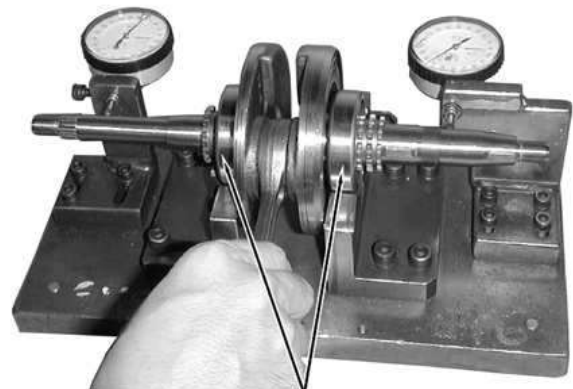

Crankshaft Bearings

CRANKCASE ASSEMBLY

Install the crankshaft into the left crankcase.



11. CRANKCASE/CRANKSHAFT

LIKE 200i

Install the dowel pins and a new gasket onto the left crankcase.

* Place the right crankcase over the crankshaft and onto the left crankcase.



Gasket

Tighten the crankcase attaching two bolts.

Torque: 0.9kg-m

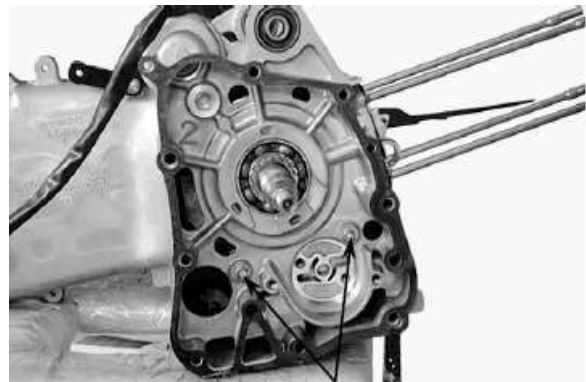

Crankcase Bolts

FUEL SYSTEM (Auto Control Fuel Injection System)

M3A DIAGRAM.....	12- 2
PARTS LOCATION	12- 3
SERVICE INFORMATION	12- 4
TROUBLESHOOTING.....	12- 5
CHECK ENGINE LAMP (CELP)	12- 6
FAILURE CODES	12- 6
FAILURE CODE LIST	12- 8
ECU MODULE	12-10
ECU PINS.....	12-14
TPI/ABV INITIALATION	12-15
FUEL PUMP/T-MAP	12-17
TPS/ETS.....	12-18
FUEL INJECTOR.....	12-19
FUEL INJECTOR CLEANING METHOD	12-21
O2 SENSOR.....	12-22
FUEL CUT-OFF RELAY	12-23
DIAGNOSTIC RECORD	12-25

M3A DIAGRAM

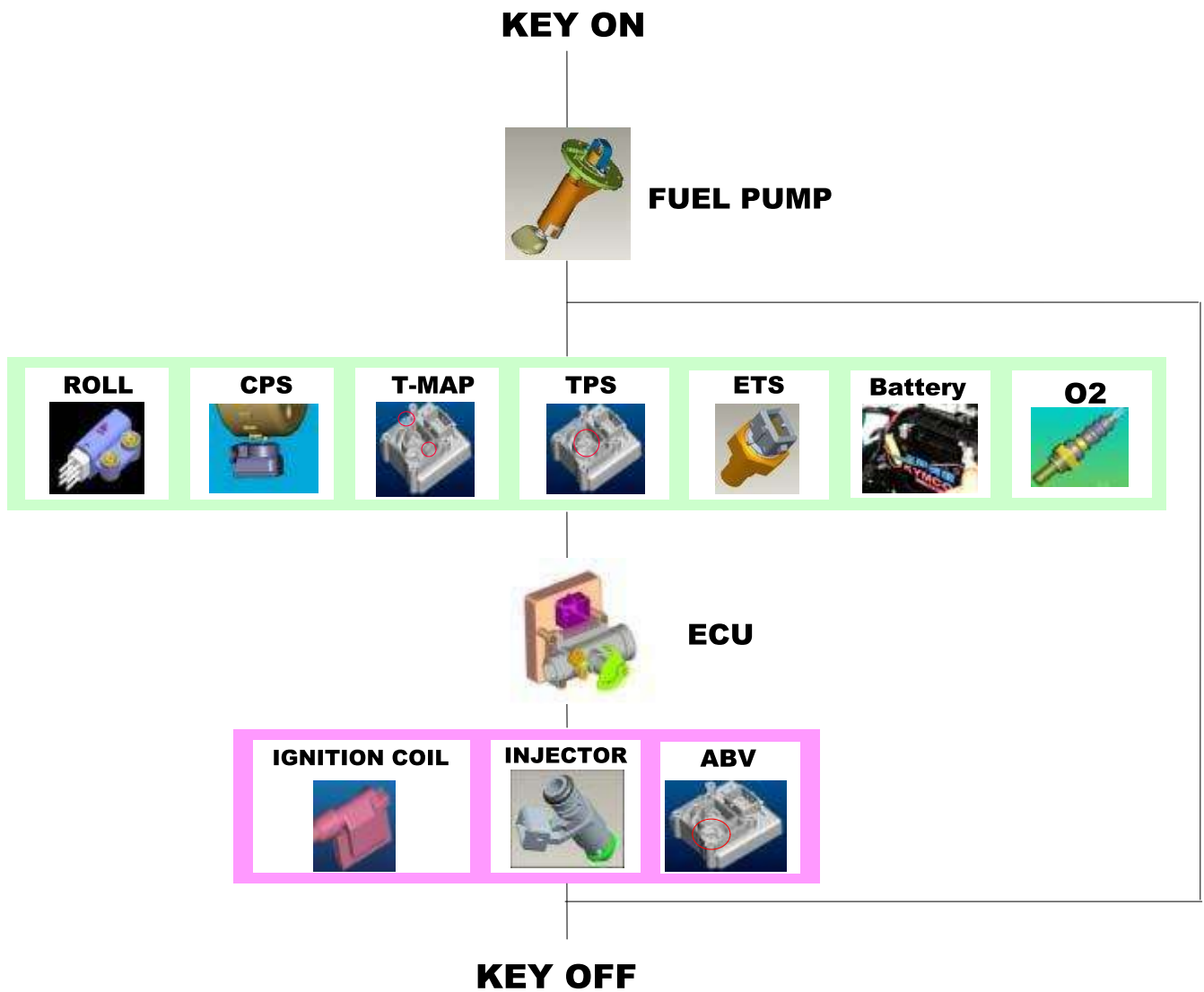

PARTS LOCATION

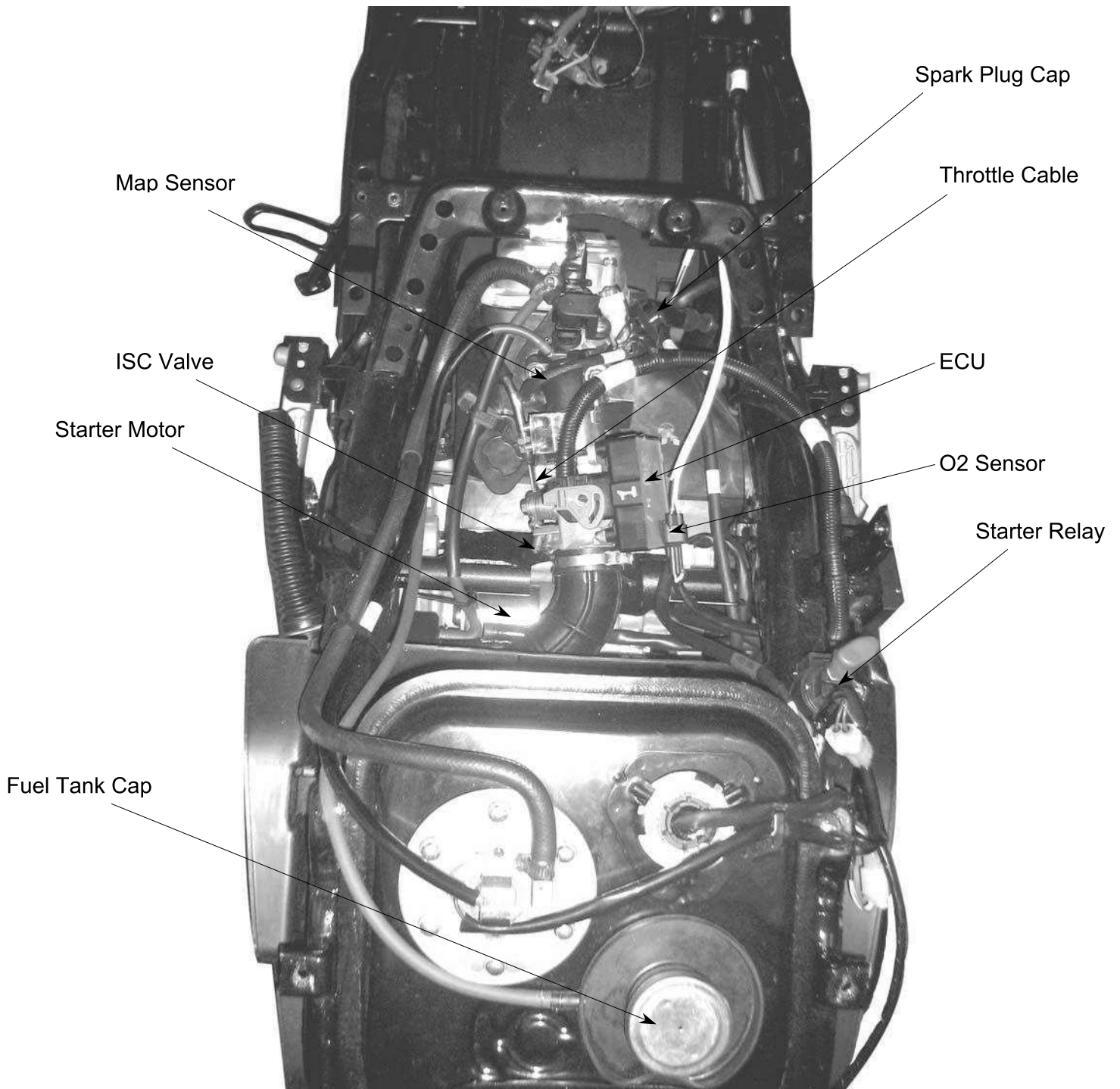

SERVICE INFORMATION

GENERAL INSTRUCTIONS

* Gasoline is very dangerous. When working with gasoline, keep sparks and flames away from the working area.
Gasoline is extremely flammable and is explosive under certain conditions. Be sure to work in a well-ventilated area.

- Disconnect the cables of the battery when the engine is running, which could lead to ECU damage.
- Connect the harness positive (+) cable to the battery negative (-) terminal or connect the harness negative (-) to the battery positive (+) terminal, which could lead to ECU damage.
- Always keep fuel over 750cc in fuel tank to prevent the fuel pump from damage.

SPECIFICATIONS

Item		Standard	
Charging voltage of battery		> 12V	
Voltage from the ECU to sensor		5±0.1V	
Fuel injector resistance (20°C/68°F)		10.6Ω ~ 15.9Ω	
Engine temperature sensor resistance		2.5kΩ~2.7kΩ (25°C)	
Throttle position sensor voltage		Idle (0°) = 0.23±0.05V Throttle fully (>90°) = >3.27V	
Fuel unit resistance		F: 7Ω±3Ω E: 95Ω±5Ω	
Crank position sensor resistance		96Ω~144Ω (20°C/68°F)	
Inductive ignition coil resistance		0.55~0.75Ω (for primary coil)	
Idle		1800±100 rpm	
Roll sensor voltage		Normal: 0.4~1.44V Fall down(Over 65°): 3.7~4.4V	
O2 sensor	Heater resistance	6.7Ω~9.5Ω (white & white)	
	Volt.	Air/Fuel<14.7 (Rich)	> 0.80V
		Air/Fuel>14.7 (Lean)	< 0.18V

TROUBLESHOOTING

Engine won't start

- Battery voltage too low
- Fuel level too low
- Pinched or clogged fuel hose
- Faulty fuel pump operating system
- Clogged fuel filter (fuel pump)
- Clogged fuel injector
- Faulty spark plug or wrong type
- Cut by ECU due to angle detect sensor or incorrect function

Engine stall, hard to start, rough idling

- Intake air leak
- Fuel contaminated/deteriorated
- Pinched or clogged fuel hose
- Idle speed misadjusted

Backfiring or misfiring during acceleration

- Ignition system malfunction

Poor performance (drive ability) and poor fuel economy

- Pinched or clogged fuel hose
- Faulty fuel injector

CHECK ENGINE LAMP (CELP)

When turning on the switch, the lamp will be lighted for two seconds then off. Let user to know the lamp is available and connect to ECU.

If the CELP starts to blink or keep lighting, it means something wrong with this vehicle, you had better to do the further check to find out the failure code to know which part get trouble

There are three kinds of priority grade, let user to know what kind of trouble was happened.

Priority grade 1:

CELP blinks continuously. This is the most emergent situation like engine over heat. User should slowdown the riding and go to dealer for checking immediately.

Priority grade 2:



CELP lights all the time. It means components gets trouble or circuit something wrong. Do the further check to find out the failure code to know which part get trouble.

Priority grade 3:

CELP just blinks once suddenly and then disappear. It sometimes just warning like the RPM was too high in a short term.



Check Engine Lamp (CELP)

PRIORITY	LAMP ACTION
1	ON  OFF
2	ON  OFF
3	ON  OFF

How To Show Failure Code

You can read the failure code by as below,

Turn switch on. The CELP will be lighted for 2 seconds then off. The CELP starts to blink to show the failure codes. The number of failure code from 1 to 25.

If vehicle got more than one failure code, the CELP will be shown from lower number failure code and then show the other higher number one after four seconds. All the failure codes would be shown repeatedly.

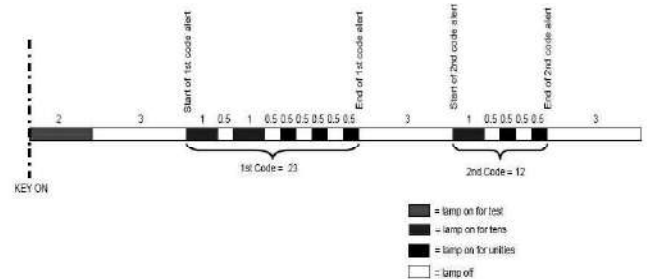

How To Reset Failure Code

After repairing the trouble, you should clear the failure code or it will still exist in the ECU memory. When you maintain for this vehicle next time, it will show again and you get confuse.

Turn switch on. The CELP will be lighted for two seconds then off.

The CELP begins to blink to show the failure codes.

The self-diagnosis memory data will be erased when all the failure codes has showed for four cycles.

FAILURE CODE LIST

Blinks	Failure Codes	Fault Description	Priority	Fault Management
1	P0217	Engine Overheating	1	1.Stop immediately and check CELP code. 2.Check engine thermo sensor wiring and connections. 3.Check engine lubrication and cooling systems. 4.Check engine ignition and fuel systems. 5.Extended periods of riding can cause engine overheating
2	P0335	Crank Position Sensor (CPS) Fault	2	1.Check Crank Position Sensor(CPS) wiring and connections. 2.Check CPS tp flywheel gap (0.6mm-1.2mm). 3.Check crankshaft runout. 4.Use ohm meter to check circuit resistance (100-130 ohms with engine cool).
3	P1120	Throttle Position Sensor (TPS) Fault	2	1.Use KYMCO AFI Diagnostic Tool to reset code. Ensure TPS is within specs. (With throttle plate closed-0.68 volts +/- 0.03 volts). 2.Check TPS wiring and connections. 3.Ensure that TPS value to be 0% when throttle plate is closed.
4	P1121	Throttle Position Sensor (TPS) output is abnormal	2	1.Check TPS wiring and connections. 2.Use KYMCO AFI Diagnostic Tool to measure voltage (below 0.5 volts). 3.Ensure that TPS screw has not been adjusted unnormally, TPS should be 0% when throttle plate is closed.
5	P1122	Throttle Position Sensor Velocity Fault	2	1.Check TPS wiring and connections. 2.Use KYMCO AFI Diagnostic Tool to measure voltage (below 0.5 volts). 3.Ensure that TPS screw is adjusted to 0% when throttle plate is closed. 4. Replace TPS sensor
6	P0560	Battery Voltage abnormal	1	1.Using volt meter, check battery voltage (12-15 volts). 2.Using volt meter, check stator output (13.5-14.5 volts). 3.Check black, blue, and red wires on ECU for shorts. 4.Check battery condition.
7	P0110	Inlet Air Thermosensor (IAT) Fault	2	1-Check IAT wiring and connections. 2-Using Ohm meter, check IAT resistance (2554-568.9 ohms within 20~60 degree centigrade).
8	P0410	Idle Air Bypass Valve (IABV) Fault	2	1.Check IABV wiring and connections. 2.Using Ohm meter, check IABV resistance (24.7-27.3 ohms). Note-IABV is powered by the battery
9	P0505	Idle Air Bypass Control Range Fault	2	1-Check idle bypass valve opening is within specs. (brand new: above 35 degree used: <180 degree) 2.Check throttle body for carbon deposits. 3.Check Idle Throttle Valve for sticking and check adjustment of screw. 4. Check intake for air leaks 5. Replace the IABV 6. Note-IABV is powered by the battery
10	P0251	Fuel Injector Fault	2	1.Use ohm meter to measure resistance (13.78-15.23 ohms). 2.Check injector wiring and connections. 3.Check battery wiring and connections. Note-Fuel Injector is powered by battery
11	P0350	Ignition Coil Fault	2	1.Verify ignition is within specs (0.57-0.66 ohms) 2.Check wiring and connections. 3.Check condition of battery wiring and connections.

12. FUEL SYSTEM

LIKE 200i

Blinks	Failure Codes	Fault Description	Priority	Fault Management
12	P0230	Fuel Pump Relay Fault	2	1. Check wiring and connections. 2. Listen for relay clicking when ignition is switched on.
13	P0219	Engine Over Speed Condition Fault	2	1. Engine exceeded 10,500 rpm redline. 2. Check belt. 3. Check spark plug. Use resistor plug "R".
14	P1560	Sensor Power Supply Fault	2	1. Use volt meter to check ECU pin 18 (5 volts DC) or use diagnostic tool (5 volts +/- 0.1 volts). 2. Check voltage difference between pin 16 and pin 18 (5 volts DC). 3. Cylinder head Temperature Sensor, Intake Air Temperature Sensor, and TPS use the same power supply. If getting more than three faults, ECU could be faulty.
15	P0700	Engine RPM/CVT Fault	2	1. If engine exceeds 3250 rpm at idle, ECU will lower engine idle speed or shut engine down. 2. When start the engine, Do NOT use throttle 3. Check throttle cables and throttle body for sticking and binding. 4. Check throttle idle voltage (0.68 volts +/- 0.03 volts). 5. Check CVT belt.
16	P0115	Cylinder Head Thermosensor Fault	2	1. Use voltmeter to check resistance (cold 2445.2-5458.3 ohms). 2. Check wiring and connections for ECU pin 9.
18	P0650	Check Engine Light Fault	3	1. Check bulb (1.7w 12 volt DC). 2. Check ECU wiring and connections pin 4.
21	P0105	Atmosphere Pressure Sensor Fault	2	1. Check sensor voltage (5 volts +/- 0.1 volt). 2. Check ECU wiring and connections pin 8. 3. Use Diagnostic Tool to check pressure (101.3 +/- 3 KPA).
22	P1110	Bank Angle Detector Sensor Fault	2	1. Use KYMCO AFI Diagnostic Tool Check sensor voltage (3.5~4.7 volts). 2. Check ECU wiring and connections pin 11. 3. If still getting fault, replace sensor.
23	P0136	O2 Sensor Fault	1	1. Check sensor resistance (Standard: 6.7~9.5Ω @20°C ~30 °C). 2. Check ECU wiring and connections pin 10. 3. If still getting fault, replace sensor.
24	P0141	O2 Heater Sensor Fault	2	1. Check ECU wiring and connections pin 14. 2. If still getting fault, replace sensor.
25	P0171	Close loop Fault	1	1. Check wiring and connections pins 10 and 14. 2. If still getting fault, the injector probably injected more fuel or inlet air adnormal. Check if the injector is cloged, if the valve timing is correct or valve leaking, if the piston and ring piston is damaged....and so on.

SYNERJECT M3A ECU MODULE

Function and structure

ECU module is designed to be used with DC 8~16V battery as its power resource, which combines ECU, TPS, ABV and T-MAP as a module, equips totally 32 functional pins. A microchip inside records a program to communicate and deal with all information. This module includes an interface loop to detect and handle the condition of engine, and has the driven loops for fuel injector, fuel pump and inductive ignition coil.

Disassembly of ECU module

Except technician who has been qualified by KYMCO, disassembling this module will be forbidden

1. Do not remove the ECU module before switching off.
2. Removing luggage box and fixed bolts of battery ⊕ ⊖ terminals (remove ⊖ terminal first, then ⊕ terminal).
3. To push the stopper and release the pulling rod of ECU module coupler. Rotate the rod while you hearing a click, remove the coupler.
4. To release screw, connecting pipe's bolt, inlet manifold and ECU module separately.
5. Releasing the fixed nut of the throttle cable and remove the cable.
6. To remove ECU module.
7. Removing four fixed screws to separate throttle body from ECU module.

Assembly would reverse the steps of disassembly.

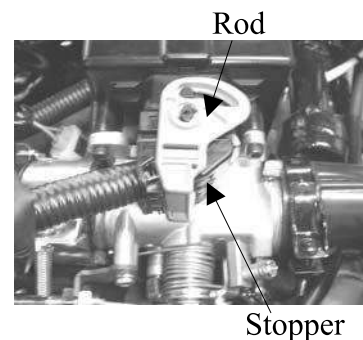
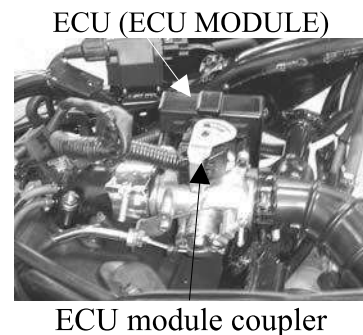
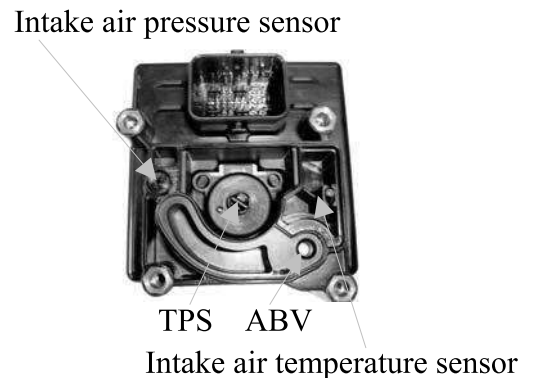

ECU module is a precision electronic component, noticing items as following:

1. Don't put it in water.
2. Don't remove battery while the ignition switch is on or could burn the circuit of ECU.

ECU Module Replacement

When switch is on and battery is connected, don't remove ECU module, connect additional wire or cut any wire.

1. Make sure to replace the ECU module after the ignition switch is turned off.
2. To identify if new ECU with certain version, check with sticker on ECU or with diagnostic tool.
3. To aim the axle of throttle at knob of TPS then assemble the ECU module and install to vehicle.
4. After assembling ECU module, to confirm if operating throttle smoothly and throttle back in position precisely when release acceleration.
5. Proceeding TPS initial and adaptation setting after replacing the ECU module would be necessary.
6. Connecting diagnostic tool to the diagnostic connector, to check if throttle position and output voltage from TPS are out of the range.

Item	Specification
TPS voltage	Idle (0°)=0.23±0.05V Throttle fully(>90°) = over3.27V

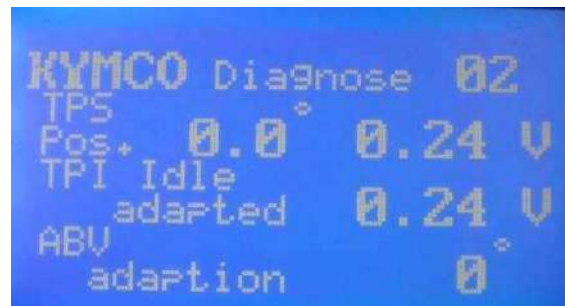

7. To run the engine till reaching the working temperature and check with diagnostic tool and refer to the related diagnostic report, to confirm all figures are fitted in standard. (Especially notice if there is any abnormal leaking symptom or unstable situation at idle speed)

ECU MOUDLE

REMOVAL

- To dismantle the throttle cable.
- To disconnect the coupler from ECU module.
- To release the bolts of clamp of intake manifold
- To remove the vacuum pipe.
- To remove the ECU module.

* First, push the stopper of coupler to release the rod, then pull back the rod to a lower fixed position after hearing click and then remove the coupler.

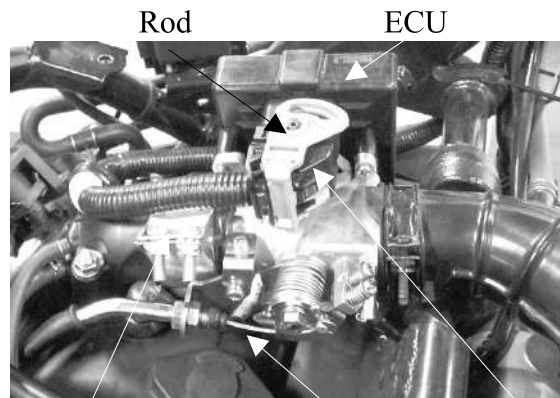

Clamp of manifold Throttle cable Stopper

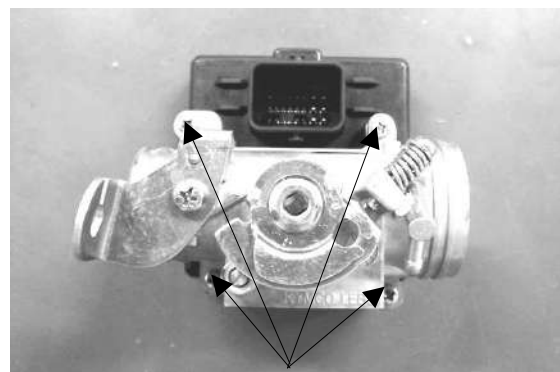

Fixed screws

- To push the stopper and release the pulling rod.
- To ensure the rod back to the lowest fixed position, while you hearing a click, you have succeeded in removing the ECU module

* ECU module and coupler are extremely expensive components just like which used in mobiles, so you need to remove and install the component carefully, prevent from increasing the maintenance cost by damaging components.



Pulling rod

Stopper

INSTALLATION

To confirm if the pulling rod of coupler is in a lower fixed position before installation or would fail to install the ECU module.

To install the coupler to ECU module (notice its direction).

To press the top of coupler with the finger and rotate the pulling rod by thumb at the same time, in the meantime, bumps of ECU seat should be engaged with the track of rod.

When the rod has been rotated to the top position, the stopper will fix the rod prevent from loosen, while you hearing a click, you have succeeded in installation.

Step 1



Step 2



Step 3



Step 4



Step 5



Step 6



ECU PIN FUNCTION

Pin	Color	Name	Funcion	Pin	Color	Name	Funcion
A1				E1			
A2				E2			
A3	P/G	CAN-HIGH	Idle speed control (ISC) B (+)	E3	P/R	DIG-2	TPLAPC RESET
A4	P	CAN-LOW	Idle speed control (ISC) A (+)	E4			
B1	G/W	CRK-NEG	Crank pulse sensor ground	F1			
B2	L/Y	CRK-POS	Crank pulse sensor	F2			
B3		NC2		F3	L/R	CELP	Multi indicator lamp
B4	L	K-LINE	Diagnostic tool	F4	R	VBD	Battery
C1	V/R	V-SENS	Sensor power output (+5V)	G1	W/R	INJ	Injection
C2	G/L	ECT	Engine temperature sensor	G2	L/B	FUEL-PUMP	Fuel pump relay
C3				G3			
C4				G4	B/L	VBK	ECU Power (Key Switch)
D1	V/G	SGND	Sensor ground	H1	W	HEGO-HEAT	HEGO HT sensor (O2 HT sensor)
D2	B	HEGO-SENS	HEGO sensor (O2 sensor)	H2			
D3	B/W	TSW	Tilt switch	H3	B/Y	IGN	Ignition power
D4				H4	G	PGND	Power ground

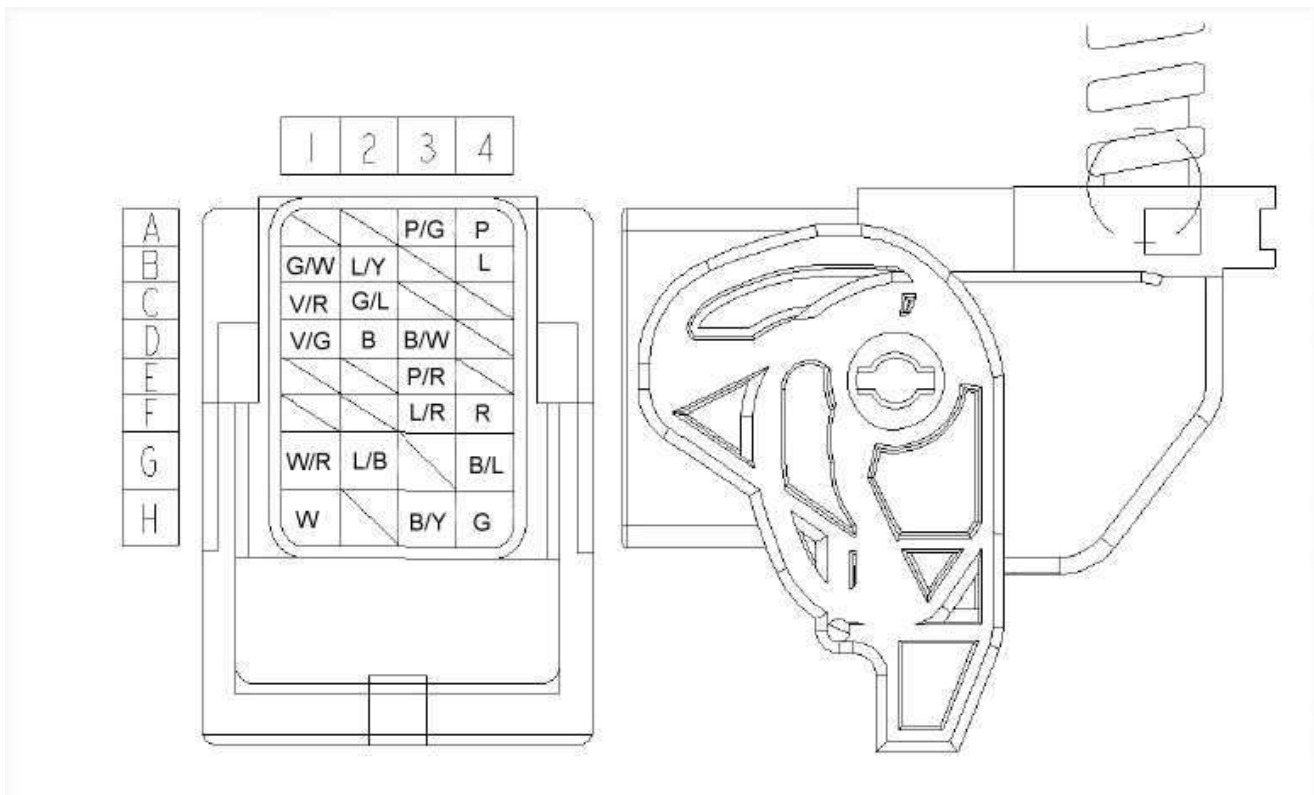

TPI / ABV INITIALIZATION

Switch off the vehicle and then switch on. (To ensure the engine is not running).

There is an initial terminal (pink wire) which is located beside the diagnostic cable. To ground the initial terminal to battery \ominus terminal or frame ground by an additional wire that will succeed in initialing TPI and ABV value which recorded in ECU.



After grounding the initial terminal, remove it back to original position and don't keep connecting this terminal.

After replacing the throttle body or engine overhauled, the efficiency of air intake would be changed, have to do the TPI/ABV initialization process.

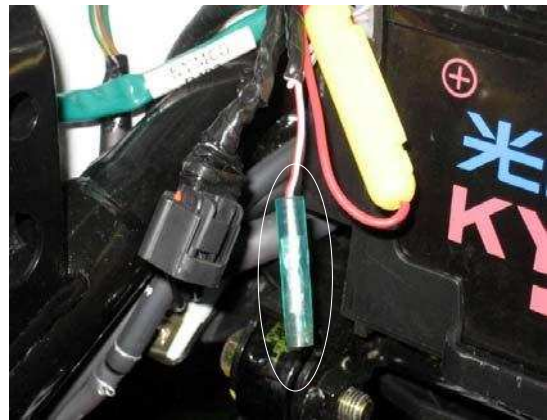

ECU ADAPT THE NEW THOTTLE POSITION VOLTAGE

Switch on and off at least three times, then ECU will adapt the new throttle position setting, each action should be stayed for more than four seconds or ECU could fail to record the new position.

INSPECTION OR RE-ADJUSTMENT OF THE OUTPUT VOLTAGE OF THROTTLE

1. Full open the throttle and then full close it at least five times and record the voltage figure when vehicle in the idle speed, checking if voltage is out of the range $0.23 \pm 0.05V$, and the variations in those five values should be $\leq 0.03 V$.
2. Accelerating a bit , that means opening the throttle around 10° and then full close the throttle at least five times, then record the voltage when in idle speed, to check if voltage is out of the range $0.23 \pm 0.05V$, and the variations in those five values should be $\leq 0.03 V$.
3. If the results of both actions above are fitted in a standard specification, it means you have finished the setting. But if either of both results above is out of the range, you need to loosen four screws a bit and reseal evenly then repeat action 1 and action 2 to recheck voltage till they are fitted in standard then tighten screws in specific torque evenly.

FUEL PUMP

Connect the voltmeter (+) probe to the red/black wire and the voltmeter (-) probe to the green wire to measure the voltage from the ECU input to fuel pump unit.

Standard : 8~16 V (Battery volt)

To measure the resistance of the fuel pump to see if it is short circuit or not.

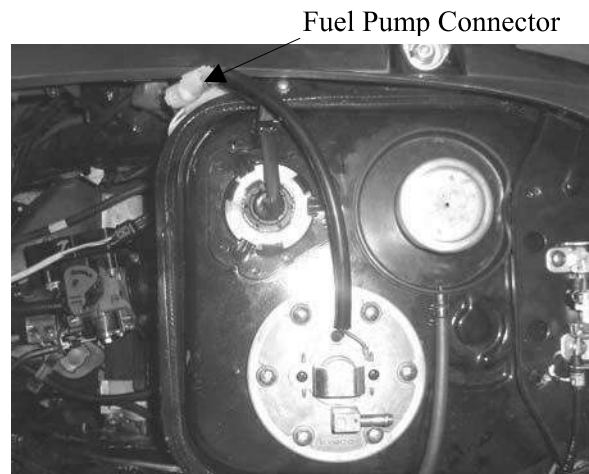

T-MAP (Manifold Air Temperature Pressure) Sensor

Connect with the Fi diagnostic tool.

Enter the Data Analyze item to check if the manifold pressure data is malfunction.

(Turn on the ignition switch but engine is not starting)

If the figure was incorrect, it means T-map sensor is problem.

Standard : 101.3 ±3 kpa



The ambient pressure drop about 12Kpa at the altitude every raised.

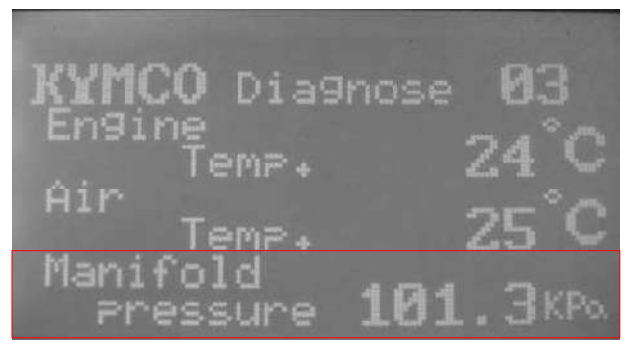
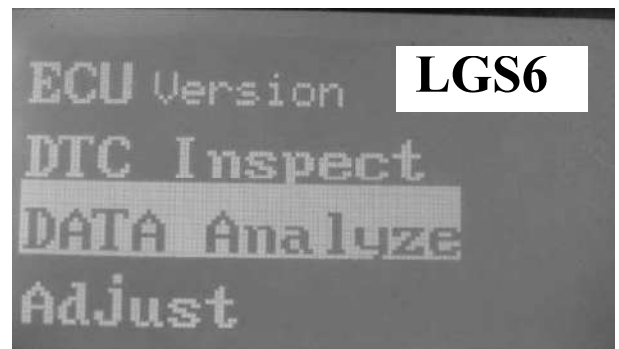

TPS (Throttle Position Sensor)

Connect with the Fi diagnostic tool.
 Choose the Data Analyze
 Check if the TPS position data is malfunction.
 (Key switch ON but engine is not started)
 If data was incorrect when the idle and throttle fully opened, TPS is possible to be problem.

Standard:

Item	Specification
TPS volt	Idle (0°)=0.23±0.05V Throttle fully(>90°) = over 3.27V

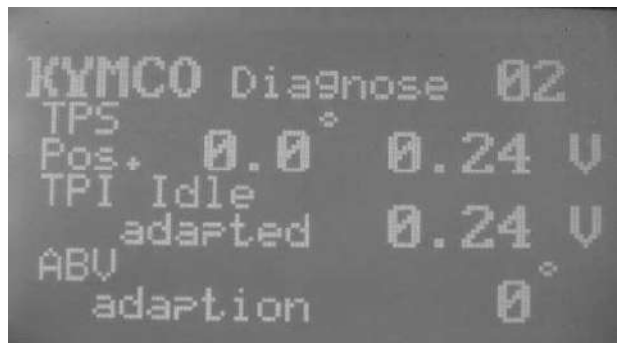
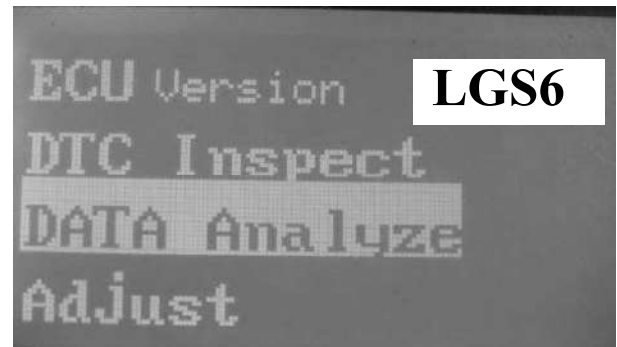

Connector



Engine Temperature Sensor

ENGINE TEMPERATURE SENSOR

REMOVAL

Remove the throttle body
 Dismantle the intake manifold
 Disconnect the connector of engine temperature sensor
 Remove the engine temperature sensor

INSPECTION

The ignition is turned off
 Disconnect the connector between engine temperature sensor and harness wires
 The ignition is turned on
 Measure the input voltage from ECU to engine temperature sensor, voltmeter ⊕ probe to G/L wire and voltmeter ⊖ probe to V/G wire

Standard: 5±0.25V



Measure the resistance for the engine temperature sensor's wires

Standard: 8.24~14.4K Ω

Torque: 0.6~0.9 kgf-m (4.32~6.48 lb-ft)

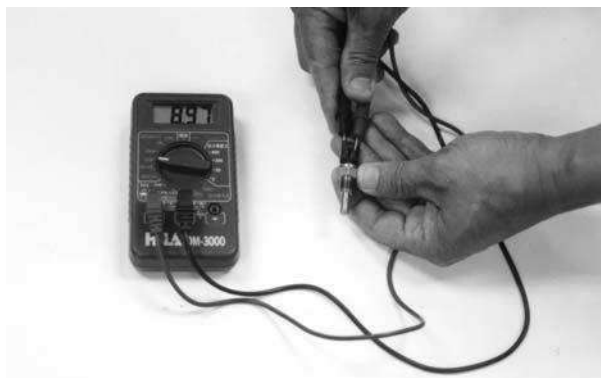

FUEL INJECTOR

INSPECTION

Measure the resistance of the Injector.

Standard (20°C/68°F): 10.6~15.9 Ω



Replace a new O-ring and lubricate with engine oil before installation.
The cleaner must be used for fuel injector special only.



INSTALLATION

Apply oil onto a new O-ring.

Install the fuel injector into the fuel pipe, being careful not to damage the two O-ring.

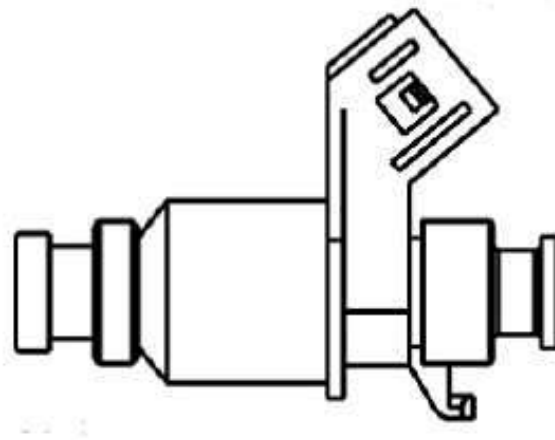

Make sure the tab on the fuel injector onto the groove of the fuel pipe.

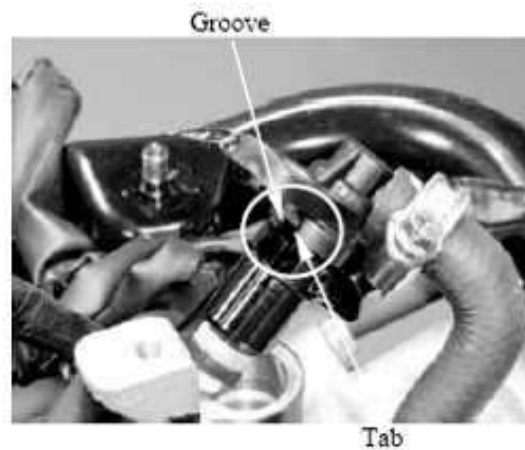

Install the fuel pipe unit onto the intake manifold by aligning the dowel pin, being careful not to damage the O-ring.

Install and tighten the fuel pipe mounting bolt.

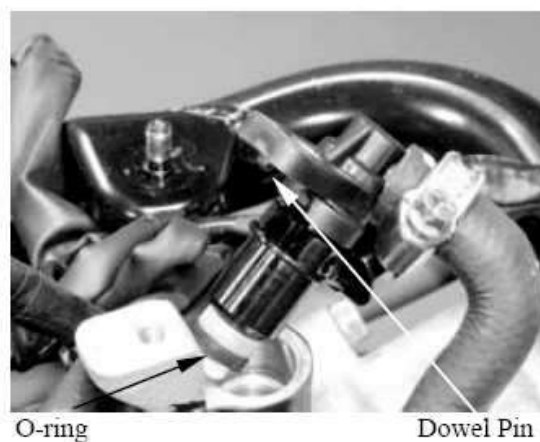

FI Fuel Injector Cleaning Method

1. Condition: Fuel Injector can't spray fuel or spray with limited quantity
2. Cause: Fuel Injector blocked by carbon deposit
3. Method
 - 1) Clean Fuel Injector with Ultrasound Cleaner with House Made Device
 - 2) The level of detergent solution in the ultrasound tank shall not exceed the height of wiring receptacle of fuel injector
 - 3) Inject detergent at the inlet port of fuel injector and clean for 30 minutes, then it can be assembled to car to start
 - 4) The method of making House Made Device

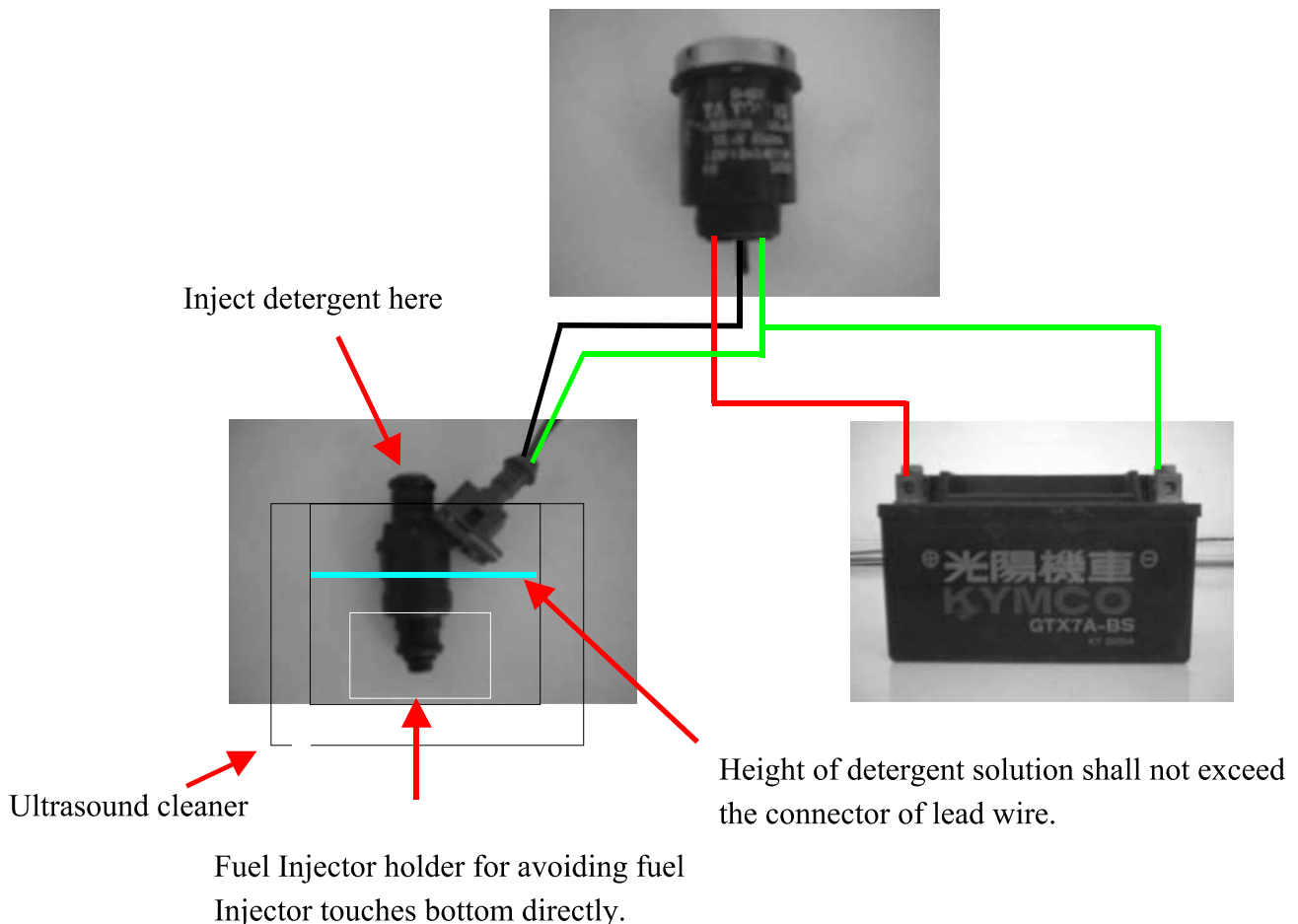

O2 SENSOR

Measure the resistance of the O2 sensor heater.
(2 white wire pin)

Standard (20°C/68°F): 6.7 ~9.5Ω



Connect the PDA or KYMCO Fi diagnostic tool.
Into the Data Analyze item .

Check Page 05

(Key switch ON then start engine until O2
heater activation is ON)

If data was incorrect.

It is possible O2 sensor is not normal



FUEL CUT-OFF RELAY

INSPECTION

Remove the fuel cut-off relay.
Connect the ohmmeter to the fuel cut-off relay connector terminals.

Connection: Blue/Black - Red/Black

Connect 12 V battery with the fuel cut-off relay connector.

Connection: Blue/Black – Black /Blue

There should be continuity only when 12 V battery connected.

If there is not continuity when the 12 V battery is connected, replace a fuel cut-off relay.

REMOVAL

Disconnect the fuel cut-off relay connector and remove it from frame.

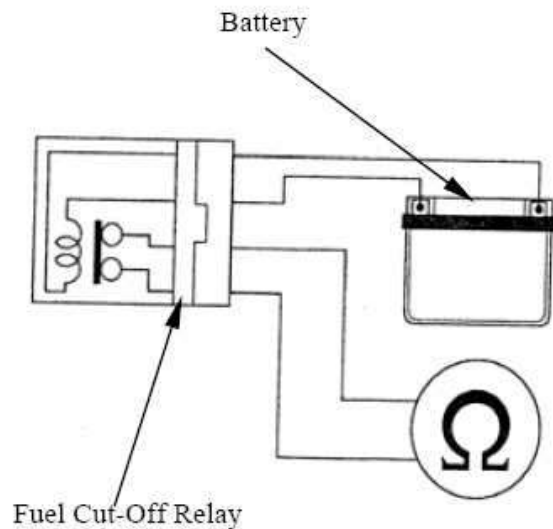

ROLL SENSOR (FUEL CUT-OFF RELAY)

The engine should be stopped running when the vehicle inclines over 65° for safety. When you place the vehicle back to normal situation, you have to key-off and key-on the switch, then it can be restarted.

Standard:

Normal: 0.4~1.4V

Over 65°: 3.7~4.4 V

Fuel Cut-off Relay

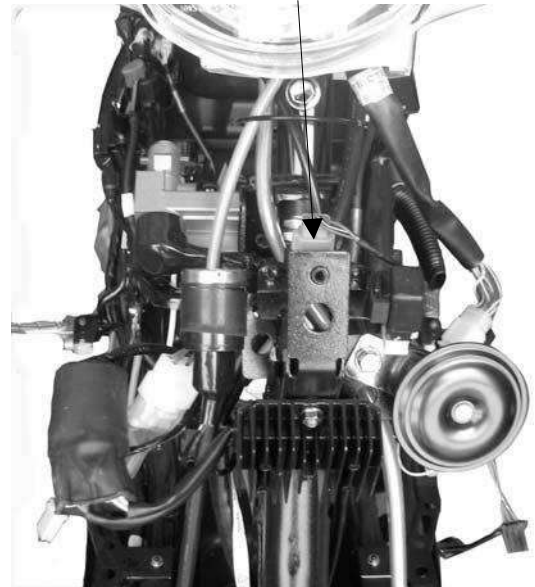

* Forbidding adjust TP screw. The best engine working condition had already been adjusted by KYMCO, if any change, maybe cause to engine problem.

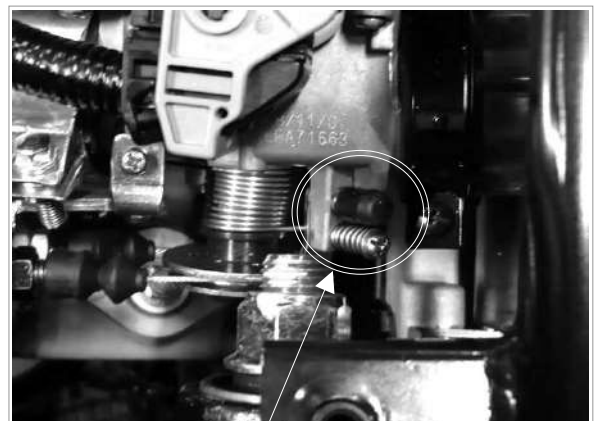

TP screw

Diagnostic Report

LIKE 200i

	Item	Reference	Data	Memo
ECU Version	ECU No	LGS6		
	Hardware Ver	116-004-G		
	Software Ver	QK0700		
	Calibration Ver	04LGS6QKAF		
	Model Name			
DTC	Active			
	Occurred			
	History			
Engine Stop	Air Temp.(°C)	environ.temp ± 2 °C		
	Engine Temp.(Coiling)	environ.temp ± 2 °C		
	Atom. Pressure(Kpa)	101.3 ± 2 kPa		
	Throttle Position(%)	00 / >900		Throttle closed / Throttle open fully
	TPI Idle Mean (V)	0.23V±0.05		Throttle closed
	TPI Wot Mean (V)	>3.27		Throttle open fully
	Battery Volt (V)	>12 V		
	Roll Sensor volt (V)	0.4~1.44V (stand)		3.7~4.4V (fall down)
(Warm up) Before Repair	EngineSpeed IDLE(rpm)	1800±100 rpm		Warm up >120°C
	MAPSample (kPa)	40 ~ 50 kpa		
	Injection duration (ms)	2.1 ~ 3.1 ms		
	Ign. Advance (°)	3 ⁰ ~ 17 ⁰ BTDC		
	O2 Sensor Voltage(V)	0 ~ 1V		
	O2 Sensor Heater	ON		
	O2 Modification %	± 20%		
	IDLE CO(%)	0.4 ~ 1.2%		
	ABVAngDurMech (°)	< 140°		Warm up >120°C
(Warm up) After Repair	EngineSpeed IDLE(rpm)	1800±100 rpm		
	MAPSample (kPa)	40 ~ 50 kpa		
	Injection duration (ms)	2.1 ~ 3.1 ms		
	Ign. Advance (°)	3 ⁰ ~ 17 ⁰ BTDC		
	O2 Sensor Voltage(V)	0 ~ 1V		
	O2 Sensor Heater	ON		
	O2 Modification %	± 20%		
	IDLE CO(%)	0.4 ~ 1.2%		
	ABVAngDurMech (°)	< 140°		Warm up >120°C

13. FRAME COVERS

LIKE 200i

ASSEMBLY DRAWING

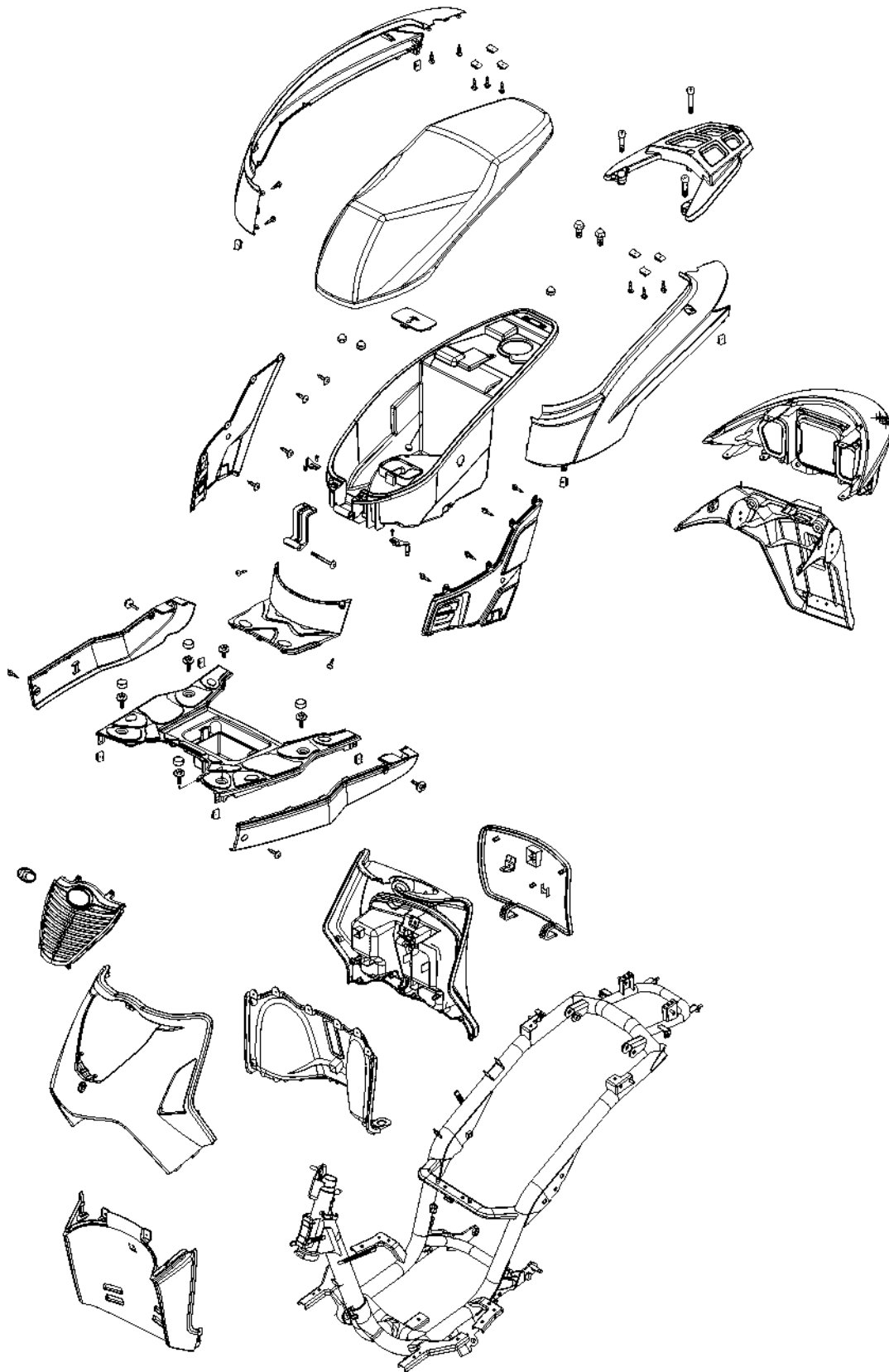

SERVICE INFORMATION

- When removing frame covers, use care not to pull them by force because the cover joint claws may be damaged.

Items Related for Removal

- Handlebar front cover ——— Headlight wire
- Front cover ———
- Handlebar rear cover ——— Speedometer cable and instrument light wire connectors, etc.
- Frame body cover ——— Met-in box, rear carrier, rear fender.
- Floor board ——— frame body cover.
- Front tool box ——— Front cover, battery, floor board .

12. FRAME COVERS

LIKE 200i

FRAME COVERS REMOVAL

REAR CARRIER

Remove the met-in box.
First remove the seven nuts attaching the met-in box.
Remove the met-in box.

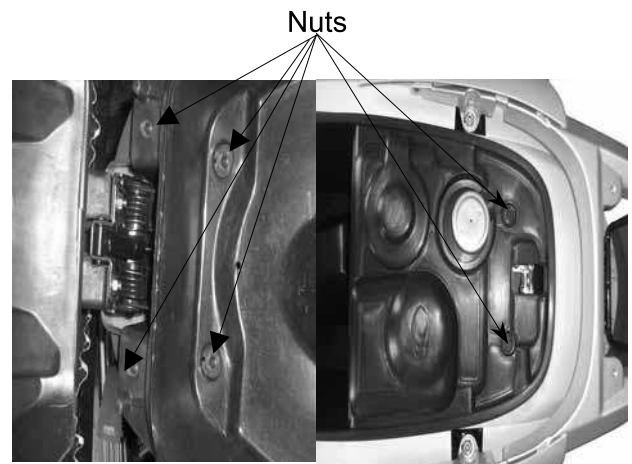

Remove the two bolts and two nuts attaching the rear carrier.
Remove the rear carrier.

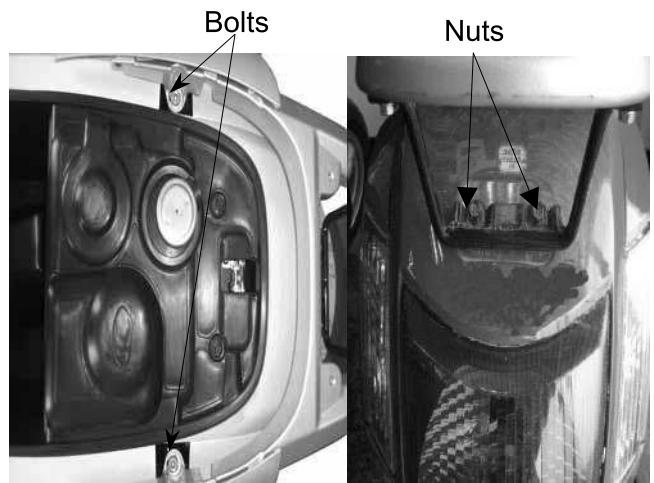

FRAME BODY COVER REMOVAL

Remove the two nuts attaching the rear protective cover.
Remove the rear protective cover



13. FRAME COVERS

LIKE 200i

Remove the two screws on the bottom of the center cover.
Remove the center cover.
Remove the body cover.

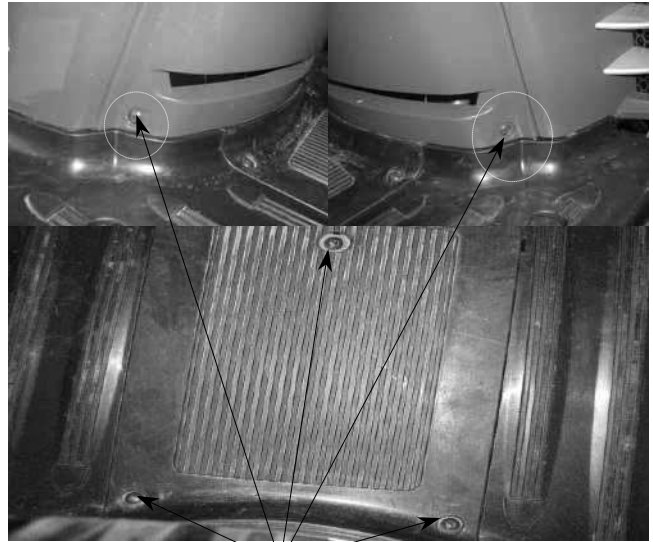

Screws
Screws

FLOOR-FOOT REMOVAL

Remove the screws attaching the right and left side covers.
Remove the right and left side covers by pulling them outward.



Side Cover
Battery Wire

Disconnect the battery wire.
Remove the battery.



Battery

12. FRAME COVERS

LIKE 200i

Remove the floor mat.
Remove the center cover. (⇒13-3)
Remove the screws and bolts attaching the front right and left side covers.
Remove the five bolts attaching the floor-foot.
Remove the floor-foot.
The installation sequence is the reverse of removal.

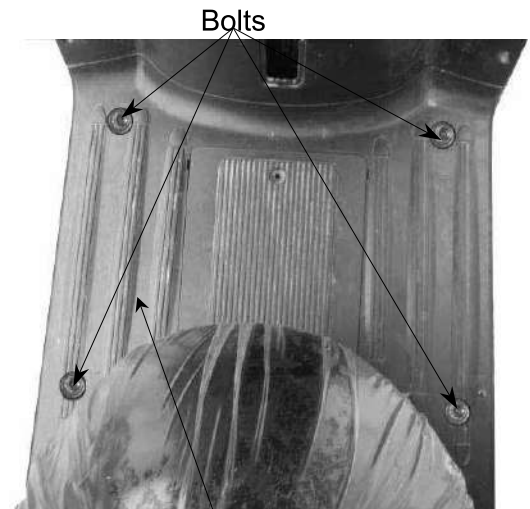

Floor-Foot
Screws

LEG SHIELD LOW REMOVAL

Remove the met-in box.
Remove the body cover.
Remove the floor-foot.
Remove the front upper cover.
Remove the four screws attaching the leg shield low.
Disconnect the leg shield low with the cowl under cover.
The installation sequence is the reverse of removal.



FRONT UPPER COVER REMOVAL

Remove the eight screws on the back of the front upper cover.
Remove the bolt on the front of the front upper cover.
Disconnect the signal light wire connector.
Remove the front upper cover.
The installation sequence is the reverse of removal.

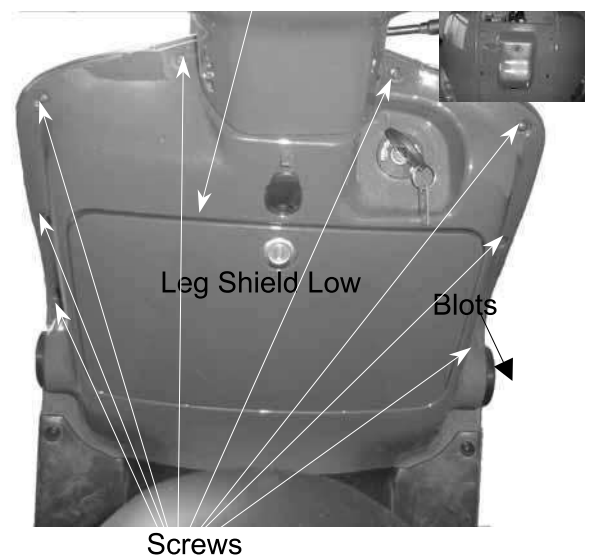

HANDLEBAR COVER REMOVAL

First remove the windshield.
Remove the two screws and two bolts
attaching the handlebar rear cover.
Remove the handlebar rear cover.
The installation sequence is the reverse of
removal.

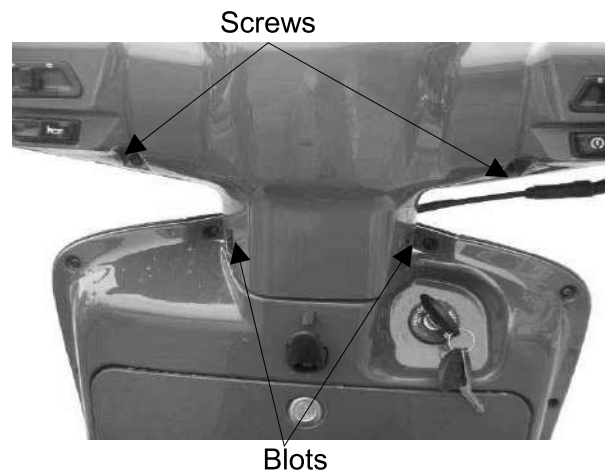

Remove the two screws attaching the
handlebar cover
Remove the handlebar cover.
The installation sequence is the reverse of
removal.

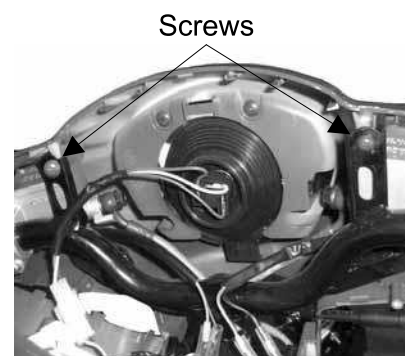

BOTTOM COVER REMOVAL

Remove the four bolts attaching the bottom
cover.
Remove the bottom cover.



EXHAUST MUFFLER REMOVAL

Remove two lock nuts from joint in the
exhaust muffler.
Remove the exhaust muffler two lock bolts to
remove the exhaust muffler.
Remove the exhaust muffler joint packing
collar.
The installation sequence is the reverse of
removal.

Torque:

Exhaust muffler joint lock nut: 2.2kg-m
Exhaust muffler lock bolt: 3.3kg-m

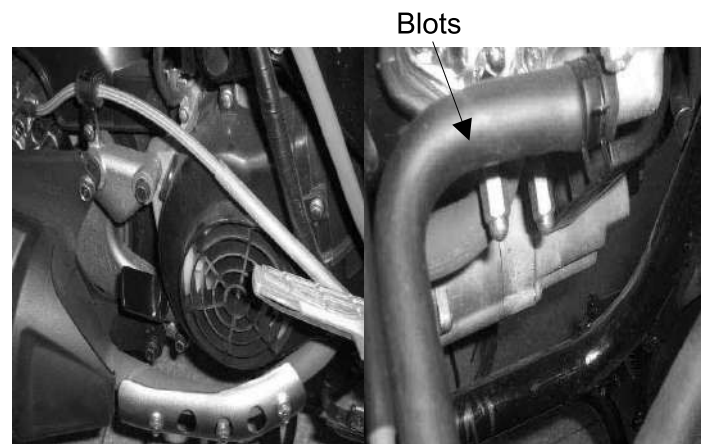

FRONT WHEEL/FRONT BRAKE/FRONT SUSPENSION

SERVICE INFORMATION	14-2
TROUBLESHOOTING.....	14-3
FRONT WHEEL.....	14-4
HYDRAULIC BRAKE DRAWING.....	14-7
HYDRAULIC BRAKE	14-8
FRONT SHOCK ABSORBER	14-13
STEERING HANDLEBAR	14-14
STEERING STEM.....	14-15

**14. STEERING HANDLEBAR/FRONT WHEEL/FRONT BRAKE/FRONT SHOCK
ABSORBER/FRONT FORK** **LIKE 200i**

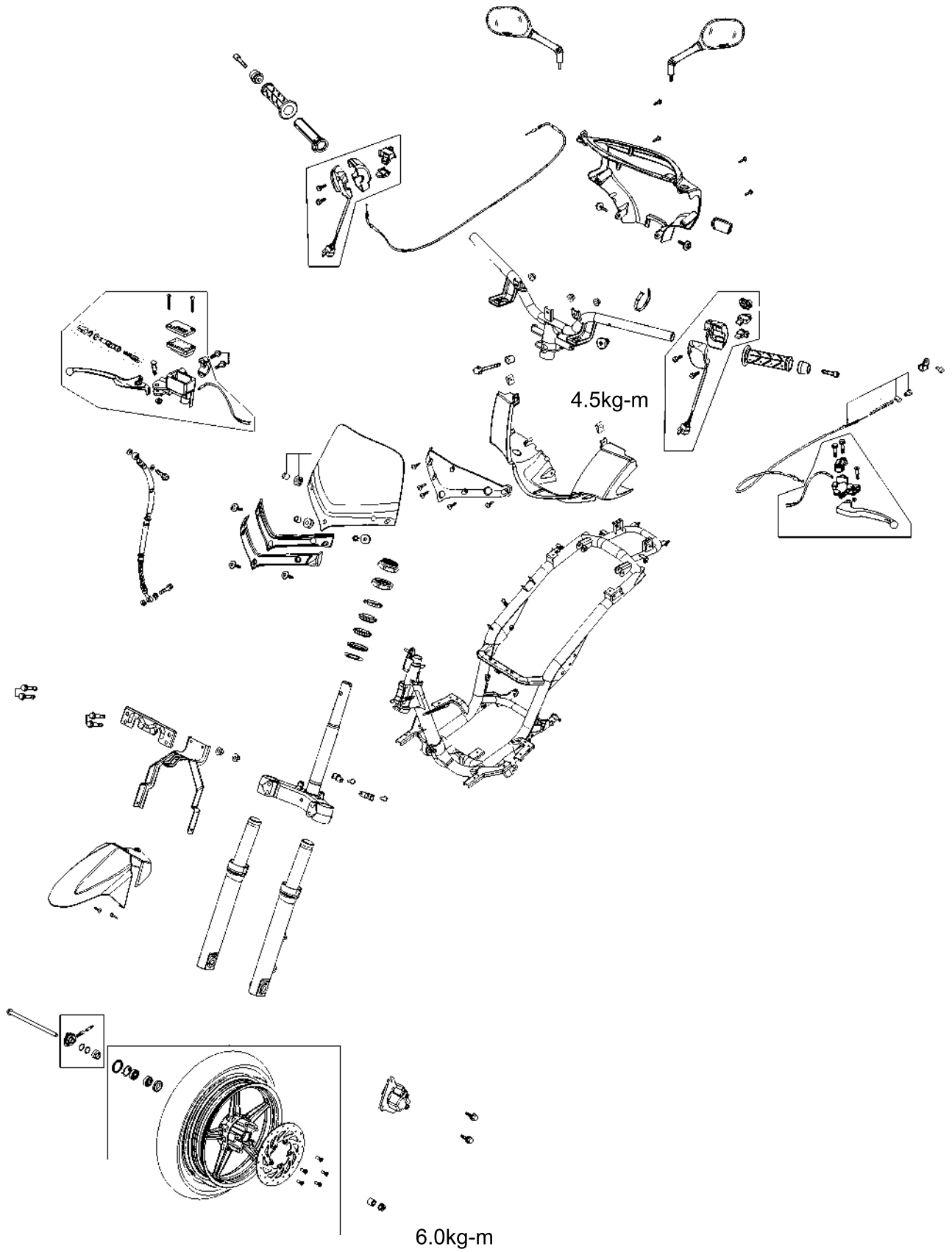

14. STEERING HANDLEBAR/FRONT WHEEL/FRONT BRAKE/FRONT SHOCK ABSORBER/FRONT FORK LIKE 200i

SERVICE INFORMATION

GENERAL INSTRUCTIONS

- Remove the motorcycle front wheel off the ground and be careful to prevent the motorcycle from falling down.
- During servicing, keep oil or grease off the brake drum and brake linings.
- Contaminated brake disk or brake pads reduce stopping power. Clean the contaminated brake disk with high-performance brake degreaser and replace the brake pads.
- Do not use brake fluid for cleaning.
- Bleed air from the brake system if the brake system is removed or the brake is soft.
- Do not allow any foreign matters to enter the brake system when filling it with brake fluid.
- Brake fluid will damage painted surfaces and plastic parts. When servicing the brake system, use shop towels to cover and protect rubber, plastic parts and coated surfaces. Wipe off any spilled brake fluid with a clean shop towel.
- Inspect the brake system before riding.

SPECIFICATIONS

Item		Standard (mm)	Service Limit (mm)
Axle shaft runout		—	0.2
Front wheel rim runout	Radial	—	2.0
	Axial	—	2.0
Front brake lining thickness		5.5	2.75
Front shock absorber spring free length		260	252
Brake disk thickness		3.2~3.5	3.0
Brake disk runout		—	0.25
Brake master cylinder I.D.		12.700~12.743	12.75
Brake master cylinder piston O.D.		12.657~12.684	12.64
Brake caliper piston O.D.		33.910~33.934	33.901
Brake caliper cylinder I.D.		33.90~33.990	34.01

TORQUE VALUES

Steering stem bolt	4.0~5.0kg-m	Brake caliper bleed valve	0.6kg-m
Steering stem lock nut	7.0~8.0kg-m	Brake fluid tube bolt	3.0~4.0kg-m
Steering top cone race	0.5~1.3kg-m	Brake pad pin bolt	1.5~2.0kg-m
Front shock absorber bolt	2.0~2.5kg-m	Brake caliper bolt	2.9~3.5kg-m
Front axle nut	5.0~7.0kg-m	Brake master cylinder bolt	1.0~1.4kg-m

SPECIAL TOOLS

Lock nut wrench

Outer driver, 28x30mm

Ball race remover

Pliers (close)

Bearing remover head, 10mm

Driver handle A

Pilot, 10mm

Outer driver, 37x40mm

Bearing remover

TROUBLESHOOTING

Hard steering (heavy)

- Excessively tightened steering stem top cone race
- Broken steering balls
- Insufficient tire pressure

Steers to one side or does not track straight

- Uneven front shock absorbers
- Bent front fork
- Bent front axle or uneven tire

Poor brake performance

- Incorrectly adjusted brake
- Worn brake linings
- Contaminated brake lining surface
- Worn brake shoes at cam contacting area
- Worn brake drum
- Poorly connected brake arm

Poor brake performance (Disk Brake)

- Air in brake system
- Deteriorated brake fluid
- Contaminated brake pads and brake disk
- Worn brake pads
- Worn brake master cylinder piston oil seal
- Clogged brake fluid line
- Deformed brake disk
- Unevenly worn brake caliper

Front wheel wobbling

- Bent rim
- Excessive wheel bearing play
- Bent spoke plate
- Faulty tire
- Improperly tightened axle nut

Soft front shock absorber

- Weak shock springs
- Insufficient damper oil

Front shock absorber noise

- Slider bending
- Loose fork fasteners
- Lack of lubrication

14. STEERING HANDLEBAR/FRONT WHEEL/FRONT BRAKE/FRONT SHOCK ABSORBER/FRONT FORK LIKE 200i

FRONT WHEEL

REMOVAL

Remove the motorcycle front wheel off the ground.
Disconnect the speedometer cable.



Speedometer Cable

Remove the front axle nut and pull out the axle.
Remove the front wheel.
Remove the front brake panel.



Axle Shaft

INSPECTION

AXLE RUNOUT

Set the axle in V blocks and measure the runout using a dial gauge.
The actual runout is 1/2 of the total indicator reading.

Service Limit: 0.2mm replace if over

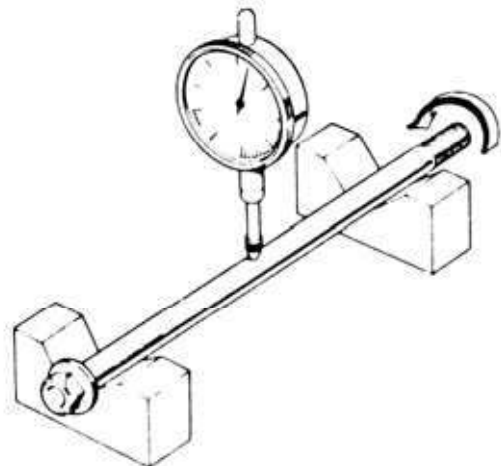

WHEEL RIM

Check the wheel rim run-out.

Service Limits:

Radial: 2.0mm replace if over

Axial: 2.0mm replace if over

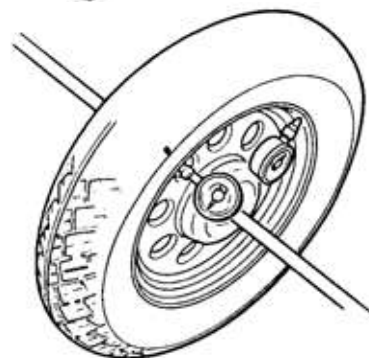

14. STEERING HANDLEBAR/FRONT WHEEL/FRONT BRAKE/FRONT SHOCK ABSORBER/FRONT FORK

LIKE 200i

FRONT WHEEL BEARING

Remove the side collar and dust seal.



Dust Seal

Turn the inner race of each bearing with your finger to see if they turn smoothly and quietly. Also check if the outer race fits tightly in the hub. Replace the bearings if the races do not turn smoothly, quietly, or if they fit loosely in the hub.



Wheel Bearing

BEARING REPLACEMENT

Remove the front wheel bearings and distance collar.

Special

Bearing Remover

Bearing Remover Head, 12mm

Pack all bearing cavities with grease.
Drive in the left bearing.
Install the distance collar.
Drive in the right bearing.

- * Do not allow the bearings to tilt while driving them in.
- * Drive in the bearing squarely with the sealed end facing out.

Special

Driver handle A



Bearing Remover



Driver Handle A

14. STEERING HANDLEBAR/FRONT WHEEL/FRONT BRAKE/FRONT SHOCK ABSORBER/FRONT FORK

LIKE 200i

Apply grease to a new dust seal lip and install the dust seal.
Install the side collar.



INSTALLATION

Apply grease to the brake panel dust seal lip.
Apply grease to the speedometer gear engaging and sliding parts.
Install the brake panel by aligning the speedometer retaining pawls with the hub cutouts.

* If not aligned, the retaining pawl will be deformed when the axle nut is tightened.
After installing the axle, turn the wheel to make sure that the speedometer drive shaft rotates freely.

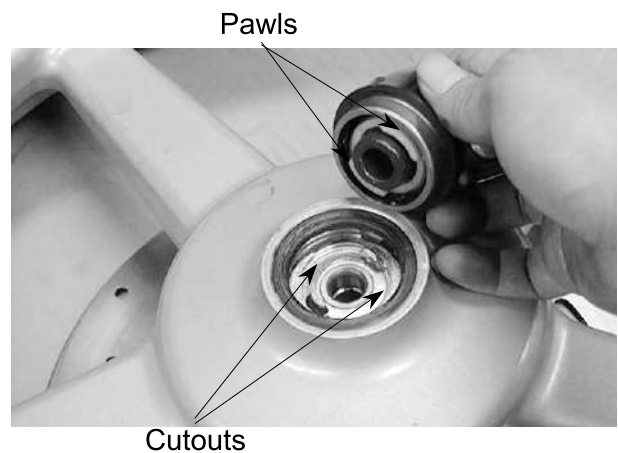

Apply a thin coat of grease to the axle shaft.
Install the front wheel by aligning the brake panel groove with the front fork tab.
Insert the axle shaft.
Install and tighten the axle nut.

Torque: 5.0~7.0kg-m

Install the front brake cable and rotate the front tire to check the speedometer if performed.

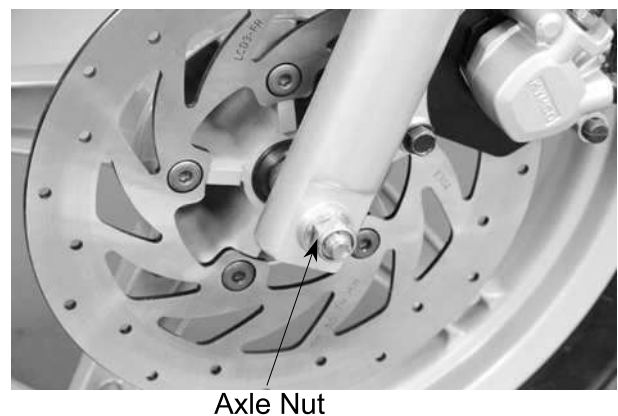

Connect the speedometer cable.

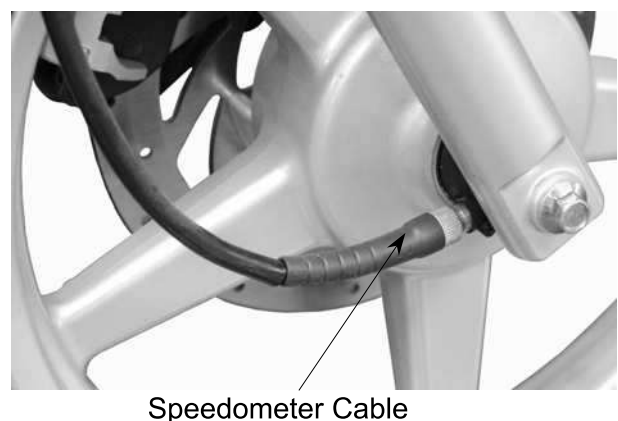

**14. STEERING HANDLEBAR/FRONT WHEEL/FRONT BRAKE/FRONT SHOCK
ABSORBER/FRONT FORK** **LIKE 200i**

HYDRAULIC BRAKE DRAWING

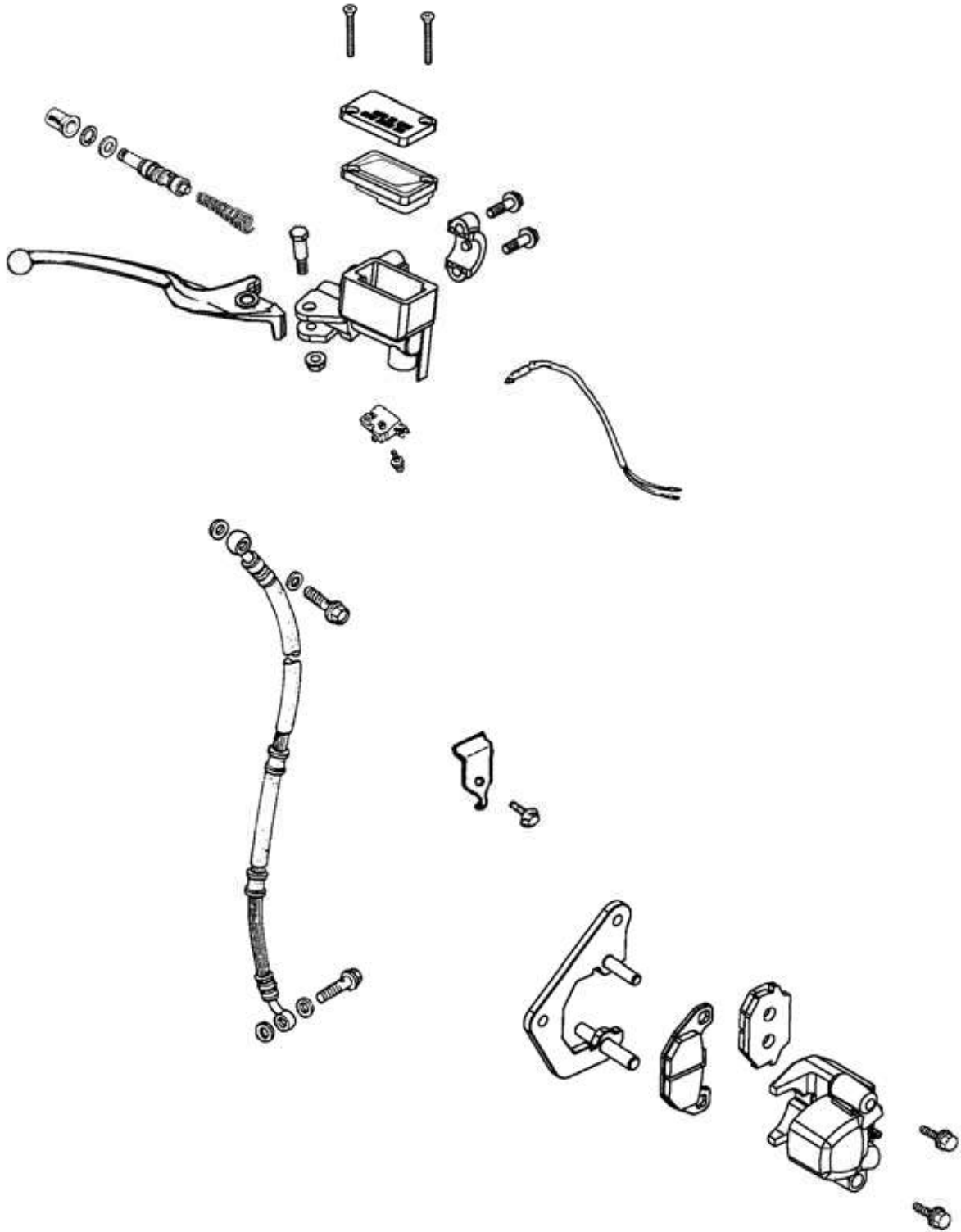

14. STEERING HANDLEBAR/FRONT WHEEL/FRONT BRAKE/FRONT SHOCK ABSORBER/FRONT FORK

LIKE 200i

HYDRAULIC BRAKE (FRONT BRAKE)

BRAKE FLUID REPLACEMENT/AIR BLEEDING

Check the brake fluid level on level ground.

- * When operating the brake lever, the brake reservoir cap must be tightened securely to avoid splash of brake fluid.
- When servicing the brake system, use shop towels to cover plastic parts and coated surfaces to avoid damage caused by splash of brake fluid.



BRAKE FLUID BLEEDING

In order to avoid spilling brake fluid, connect a transparent hose to the bleed valve.



Warning

Spilled brake fluid on brake pads or brake disk reduces stopping power. Clean the brake pads and brake disk with a high-performance brake

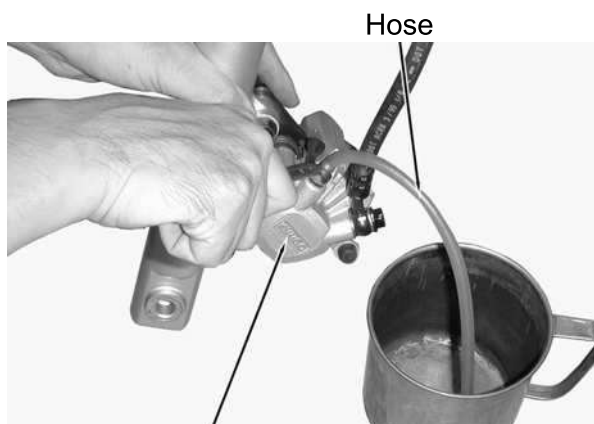

Front Brake Caliper Reservoir

Fully apply the brake lever and then loosen the brake caliper bleed valve to drain the brake fluid until there is no air bubbles in the brake fluid. Then, tighten the bleed valve. Repeat these steps until the brake system is free of air.

BRAKE FLUID REFILLING

Add DOT-3 brake fluid to the brake reservoir.

- * When bleeding, be careful not to allow air in the brake reservoir flowing into the brake system.
- Never use dirty or unspecified brake fluid or mix different brake fluids because it will damage the brake system.



Make sure to bleed air from the brake system.

BRAKE PAD/DISK REPLACEMENT



The brake pads must be replaced as a set to ensure the balance of the brake

Remove the two bolts attaching the brake caliper.
Remove the brake caliper.
Compress the brake caliper seat, and press down the fixed-reed to take out the brake pads.

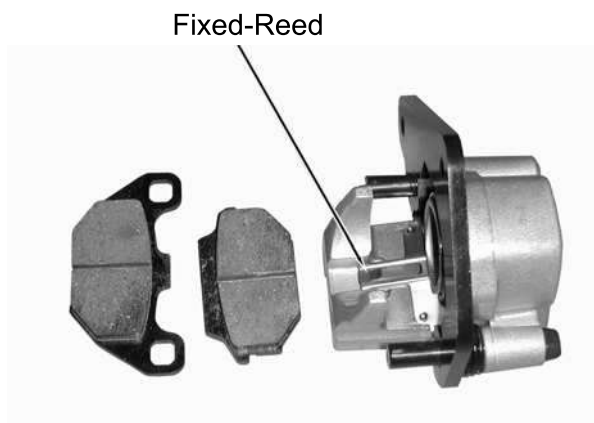

14. STEERING HANDLEBAR/FRONT WHEEL/FRONT BRAKE/FRONT SHOCK ABSORBER/FRONT FORK

LIKE 200i

Install the brake pads in the reverse order of removal.

Tighten the brake pad pin bolt.

Torque: 1.5~2.0kg-m

* Keep grease or oil off the brake pads to avoid brake failure.

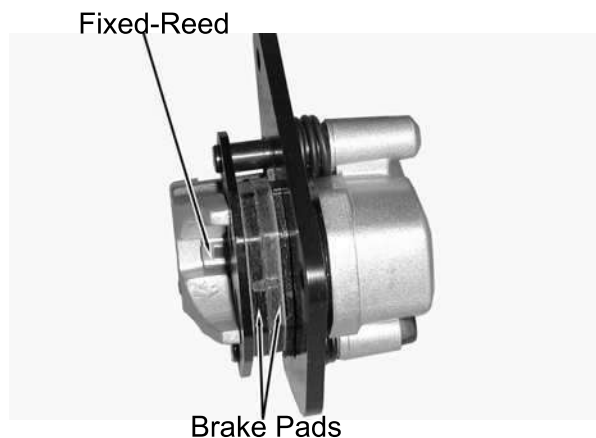

BRAKE DISK

Measure the brake disk thickness.

Service Limit: 3.0mm

Measure the brake disk runout.

Service Limit: 0.3mm



BRAKE MASTER CYLINDER

REMOVAL

First drain the brake fluid from the hydraulic brake system.

- *
 - When servicing the brake system, use shop towels to cover rubber and plastic parts and coated surfaces to avoid being contaminated by brake fluid.
 - When removing the brake fluid tube bolt, be sure to plug the tube end to avoid brake fluid leakage.

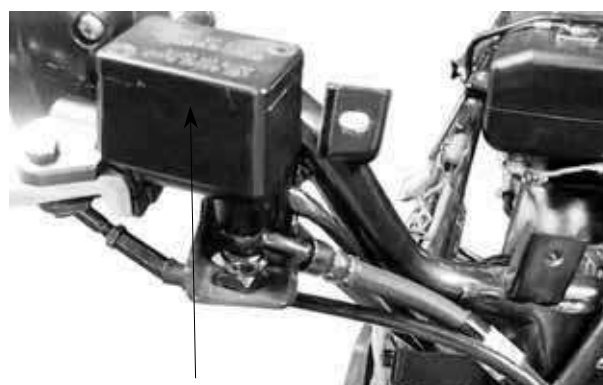

DISASSEMBLY

Remove the piston rubber cover and snap ring from the brake master cylinder.

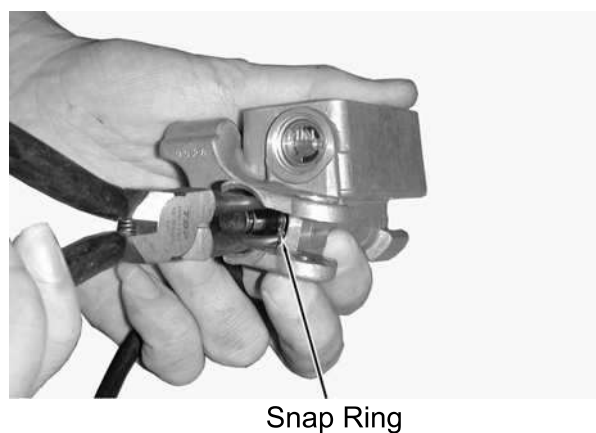

14. STEERING HANDLEBAR/FRONT WHEEL/FRONT BRAKE/FRONT SHOCK ABSORBER/FRONT FORK LIKE 200i

Remove the main piston and spring from the brake master cylinder.
Clean the inside of the master cylinder and brake reservoir with brake fluid.

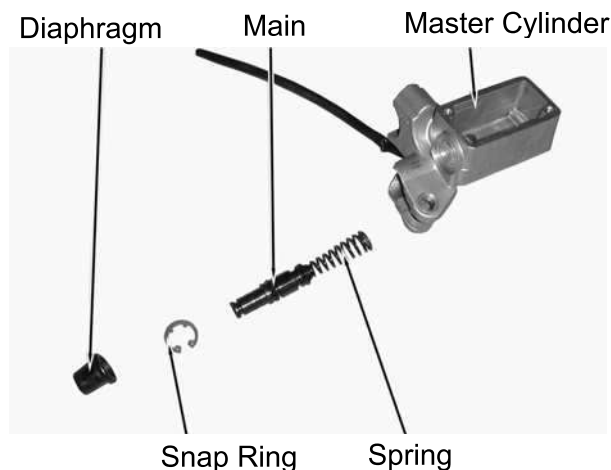

INSPECTION

Measure the brake master cylinder I.D.
Inspect the master cylinder for scratches or cracks.

Service Limit: 12.75mm



Measure the brake master cylinder piston O.D.

Service Limit: 12.75mm

Before assembly, inspect the 1st and 2nd rubber cups for wear or damage.

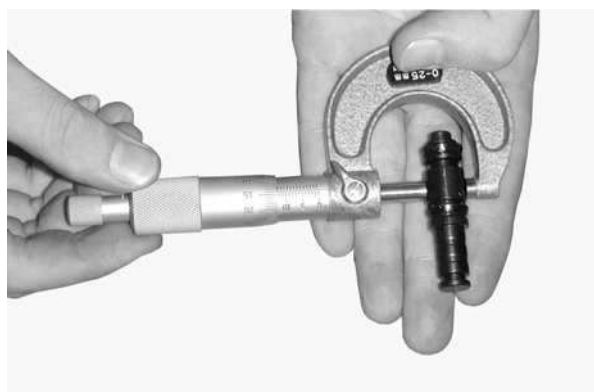

ASSEMBLY

Before assembly, apply brake fluid to all removed parts.

Install the spring together with the 1st rubber cup.

*

- During assembly, the main piston and spring must be installed as a unit without exchange.
- When assembling the piston, soak the cups in brake fluid for a while.
- Install the cups with the cup lips facing the correct direction.

Install the main piston, spring and snap ring.
Install the diaphragm.
Install the brake lever.

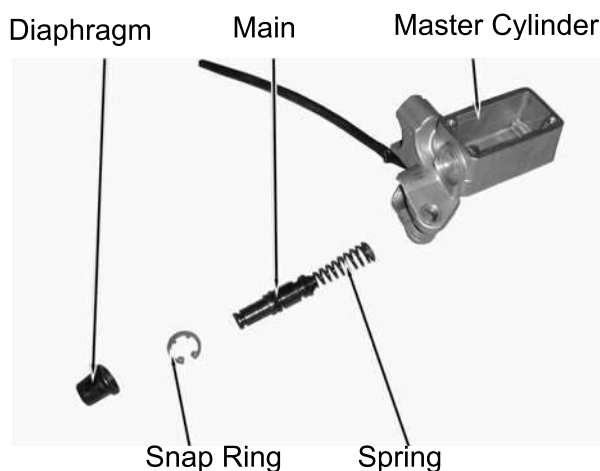

14. STEERING HANDLEBAR/Front Wheel/Front Brake/Front Shock Absorber/Front Fork

LIKE 200i

Place the brake master cylinder on the handlebar and install the holder with the “up” mark facing up. Also align the punch mark with the holder joint seam.

First tighten the upper bolt and then tighten the lower bolt.

Torque: 1.0~1.4kg-m

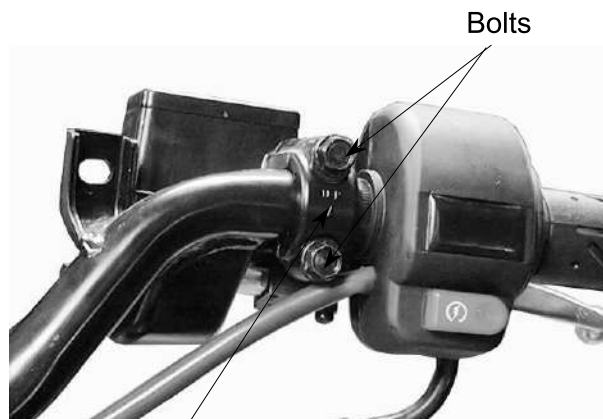

“Up” Mark

Install the brake fluid tube with the attaching bolt and two sealing washers. Install the handlebar covers. Connect the front and rear stop switch wire connectors.

Fill the brake reservoir with recommended brake fluid to the upper limit and bleed air according to the method stated in page 12-8.



Fluid Tube Bolt

BRAKE CALIPER (FRONT)

REMOVAL

Remove the brake caliper and brake pad springs.

Place a clean container under the brake caliper and disconnect the brake fluid pipe from the caliper.

* Do not spill brake fluid on any coated surfaces.

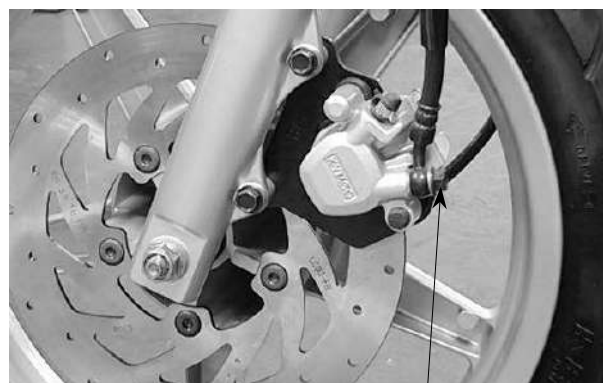

Bolt

DISASSEMBLY

Remove the brake caliper seat from the brake caliper.

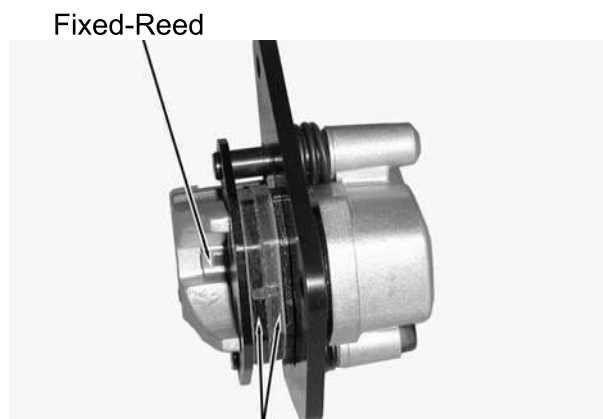

Brake Pads

14. STEERING HANDLEBAR/FRONT WHEEL/FRONT BRAKE/FRONT SHOCK ABSORBER/FRONT FORK LIKE 200i

Remove the pistons from the brake caliper.
If necessary, use compressed air to squeeze out the pistons through the brake fluid inlet opening and place a shop towel under the caliper to avoid contamination caused by the removed pistons.
Check each piston cylinder for scratches or wear and replace if necessary.

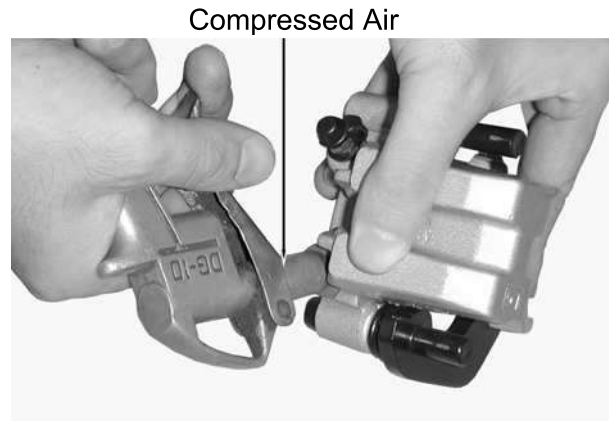

Push the piston oil seals outward to remove them.
Clean each oil seal groove with brake fluid.

* Be careful not to damage the piston surface.



Check each piston for scratches or wear.
Measure each piston O.D. with a micrometer gauge.

Service Limit: 33.90mm



Check each caliper cylinder for scratches or wear and measure the cylinder bore.

Service Limit: 33.45mm



14. STEERING HANDLEBAR/FRONT WHEEL/FRONT BRAKE/FRONT SHOCK ABSORBER/FRONT FORK

LIKE 200i

ASSEMBLY

Clean all removed parts.
Apply silicon grease to the pistons and oil seals. Lubricate the brake caliper cylinder inside wall with brake fluid.
Install the brake caliper piston with grooved side facing out.

* Install the piston with its outer end protruding 3~5mm beyond the brake caliper cylinder.



Wipe off excessive brake fluid with a clean shop towel. Apply silicon grease to the brake caliper seat pin and caliper inside. Install the brake caliper seat.

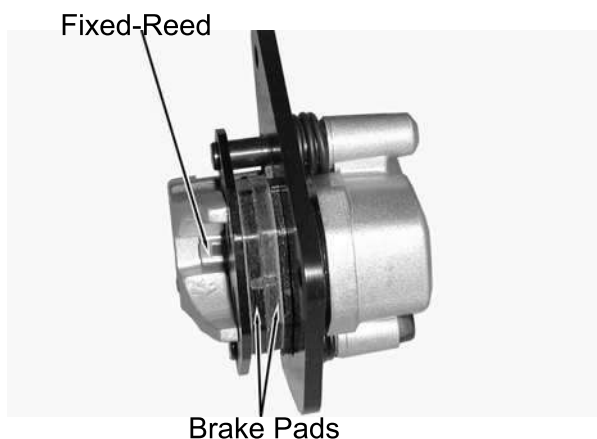

INSTALLATION

Install the brake caliper and tighten the two bolts.

Torque: 2.9~3.5kg-m

Connect the brake fluid tube to the brake caliper and tighten the fluid tube bolt.

Torque: 3.0~4.0kg-m

Fill the brake reservoir with recommended brake fluid and bleed air from the brake system.

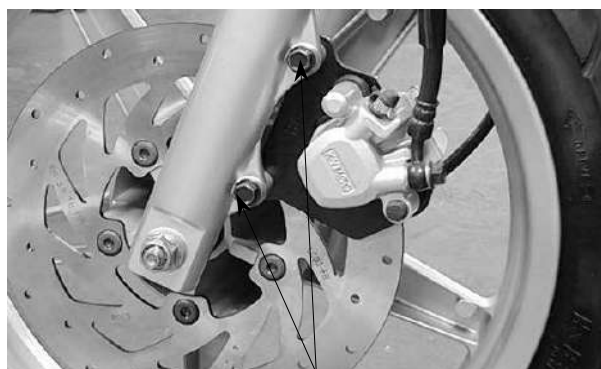

FRONT SHOCK ABSORBER

REMOVAL

Remove the front cover. (⇒12)
Remove the front wheel.
Remove the front shock absorber upper mount bolts.
Loosen the lower mount bolts to remove the front shock absorbers.

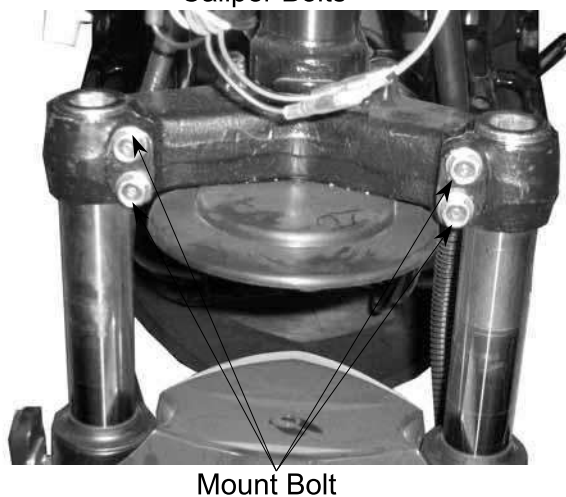

14. STEERING HANDLEBAR/Front WHEEL/Front BRAKE/Front SHOCK ABSORBER/Front FORK

LIKE 200i

INSPECTION

Inspect the following items and replace if necessary.

- Front shock absorber tube bending or damage.
- Weak front shock absorber spring.
- Damper and damper rod bending.
- Oil seal damage or wear.

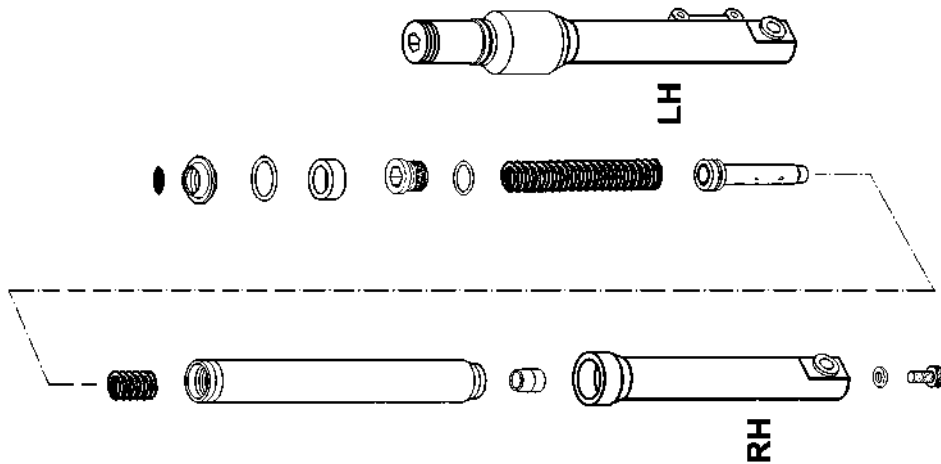

INSTALLATION

Install the front shock absorbers onto the steering stem.
Install and tighten the front shock absorber upper mount bolts.
Tighten the lower mount bolts.

* Align the upper mount bolt hole with the groove on the front fork.
Front shock absorbers are installed at the same altitude.

Install the front wheel.

STEERING HANDLEBAR

REMOVAL

Remove the handlebar covers. (⇒ 12)
Remove the rear brake lever holder bolt to remove the holder.
Remove the front brake master cylinder holder bolts to remove the brake master cylinder.

Mount Boot

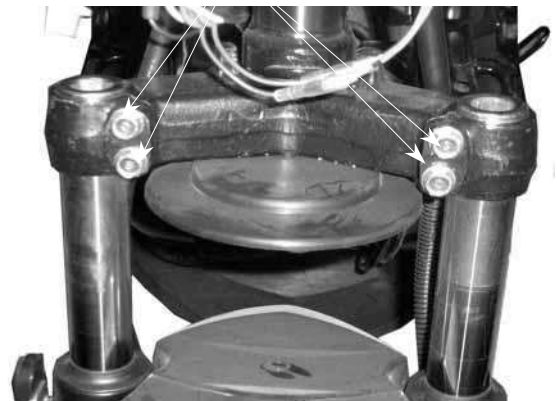

Brake Master Cylinder



Blots

14. STEERING HANDLEBAR/Front WHEEL/Front BRAKE/Front SHOCK ABSORBER/Front FORK LIKE 200i

Remove the throttle seat screw.

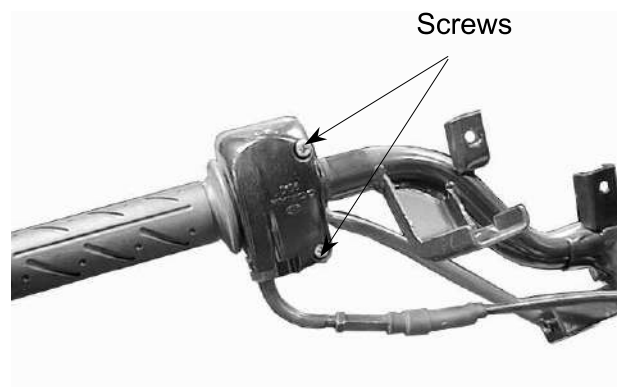

Remove the throttle seat from the handlebar and disconnect the throttle cable from the throttle pipe.
Remove the throttle pipe from the handlebar.

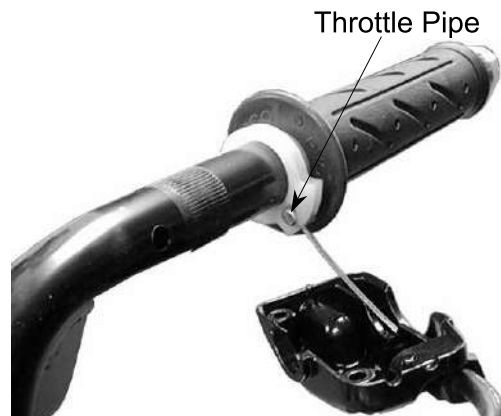

Remove the steering stem lock bolt, collar, nut and the handlebar.



STEERING STEM

REMOVAL

Remove the steering stem lock nut.

Special

Steering Stem Lock Nut Wrench

Lock Nut wrench

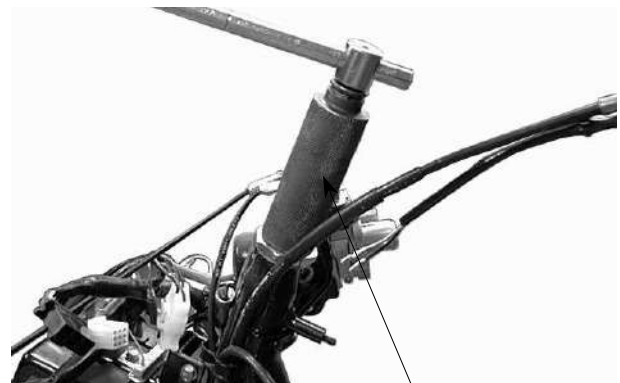

Steering Stem Lock Nut Wrench

14. STEERING HANDLEBAR/FRONT WHEEL/FRONT BRAKE/FRONT SHOCK ABSORBER/FRONT FORK

LIKE 200i

Remove the top cone race.

*

- Be careful not to lose the steel balls (20 on top race and 15 on bottom race).
- Clean the openings of frame covers with clean shop towels.

Remove the front fork.

Top Cone Race



BOTTOM CONE RACE REPLACEMENT

Remove the bottom cone race using a chisel.

*

- Be careful not to damage the steering stem and front fork.

Drive a new bottom cone race into place with a proper driver.



Bottom Cone Race
Ball Race Remover

BALL RACE REPLACEMENT

Drive out the top and bottom ball races.



Drive new top and bottom ball races into the steering head using the outer driver.

Special

Outer Driver

Outer Driver

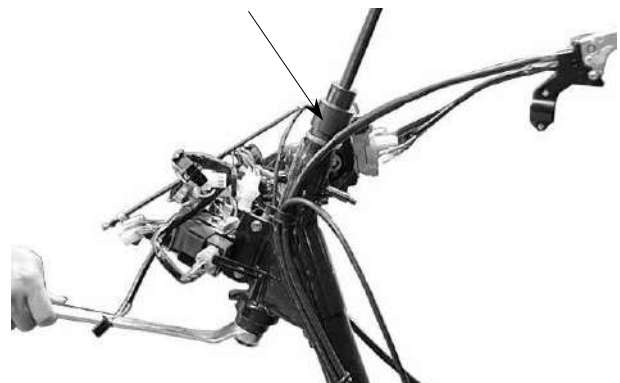

14. STEERING HANDLEBAR/FRONT WHEEL/FRONT BRAKE/FRONT SHOCK ABSORBER/FRONT FORK

LIKE 200i

INSTALLATION

Install the top and bottom steel balls.
Apply grease to the top and bottom ball races and install 20 steel balls on the top ball race and 15 steel balls on the bottom ball race.



Apply grease to the ball races and install the front fork.
Apply grease to the top cone race and install it.
Tighten the top cone race and then turn the steering stem right and left several times to make steel balls contact each other closely.



* Check that the steering stem rotates freely without vertical play.

Top Cone Race
Top Cone Race Lock Nut Wrench

Install the steering stem lock nut and tighten it while holding the top cone race.
Torque: 7.0~8.0kg-m
Install the front wheel. (⇒12)



Steering Stem Lock Nut Wrench

HANDLEBAR INSTALLATION

Install the handlebar onto the steering stem tube and then install and tighten the bolt.
Torque: 4.5kg-m
Install the front wheel. (⇒12)
Install the brake levers. (⇒12)
Install the handlebar covers.



Nut

15. REAR WHEEL/REAR BRAKE/REAR SHOCK ABSORBER

LIKE 200i

REAR WHEEL/REAR BRAKE/REAR SHOCK ABSORBER

SERVICE INFORMATION.....	15-2
TROUBLESHOOTING.....	15-2
REAR BRAKE.....	15-3
REAR WHEEL.....	15-7
REAR SHOCK ABSORBER.....	15-8

15. REAR WHEEL/REAR BRAKE/REAR SHOCK ABSORBER

LIKE 200i

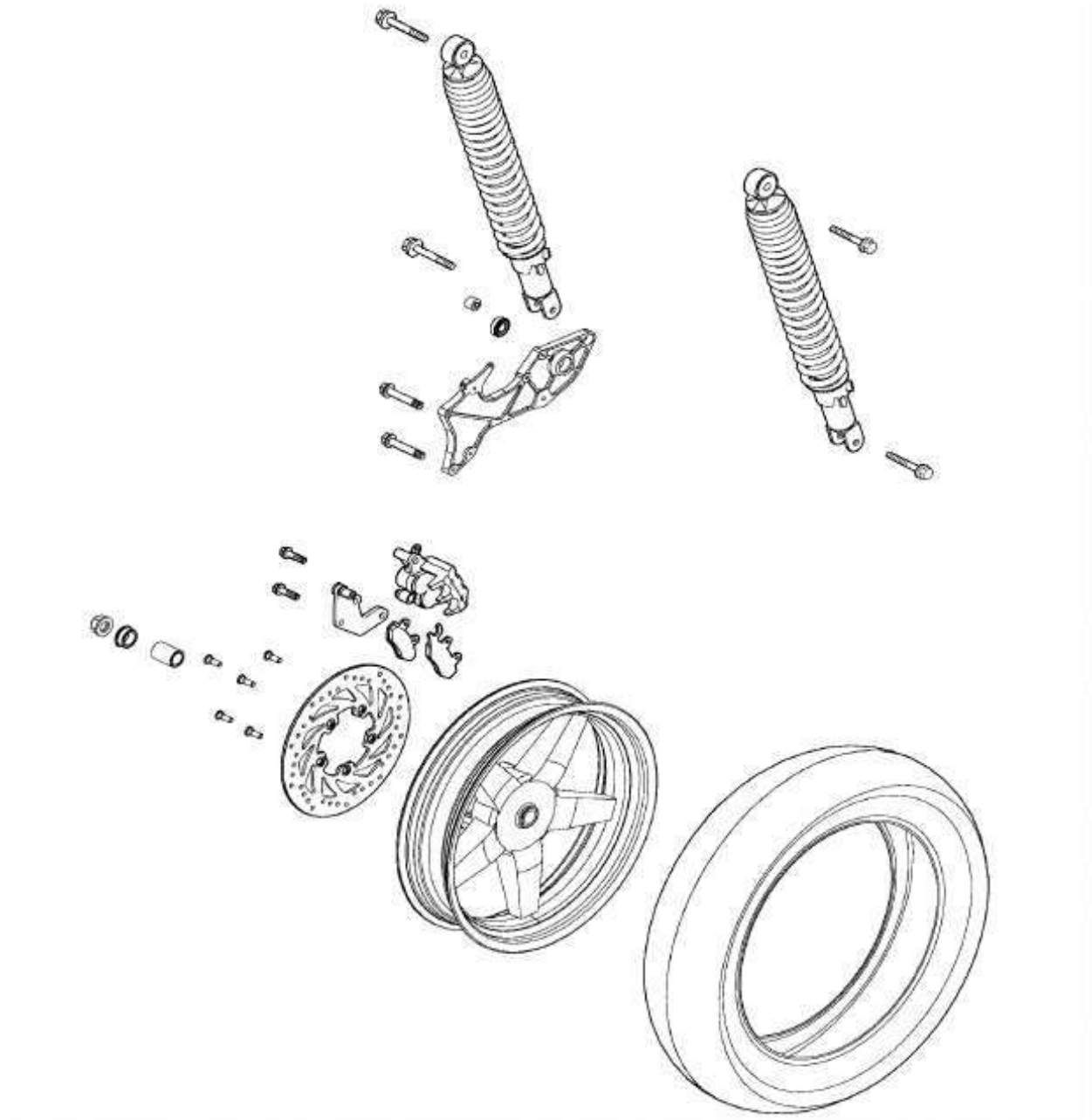

15. REAR WHEEL/REAR BRAKE/REAR SHOCK ABSORBER

LIKE 200i

SERVICE INFORMATION

GENERAL INSTRUCTIONS

- When performing the services stated in this section, the engine and exhaust muffler must be cold to avoid scalding.
- During servicing, keep oil or grease off the brake pads and brake disk.

SPECIFICATIONS

Item	Standard (mm)	Service Limit (mm)
Rear wheel rim runout	—	2.0
Rear brake disk thickness	4.0	3.0
Rear brake disk runout	—	0.30
Rear brake master cylinder I.D.	27.00	27.05
Rear brake master cylinder piston O.D.	26.95	26.90

TORQUE VALUES

Exhaust muffler lock bolt	35 N-m
Exhaust muffler pipe nut	20 N-m
Rear axle nut	120 N-m
Rear shock absorber lower mount bolt	40N-m
Rear shock absorber upper mount bolt	40N-m
Rear brake caliper holder bolt	27 N-m

TROUBLESHOOTING

Rear wheel wobbling

- Bent rim
- Faulty tire
- Axle not tightened properly

Soft rear shock absorber

- Weak shock absorber spring
- Damper oil leaks

Rear wheel noise

- Worn rear wheel axle bearings
- Worn rear fork bearings
- Deformed rear fork

Poor brake performance

- Air in brake system
- Deteriorated brake fluid
- Contaminated brake pad surface
- Worn brake pads
- Clogged brake fluid line
- Deformed brake disk
- Unequal worn brake caliper

15. REAR WHEEL/REAR BRAKE/REAR SHOCK ABSORBER

LIKE 200i

REAR BRAKE

REAR BRAKE CALIPER REMOVAL

First remove the exhaust muffler.
Remove the rear brake fluid tube bolt and disconnect the brake fluid tube.
Remove two bolts attaching the rear brake caliper.
Remove the rear brake caliper.

- When removing the brake fluid tube, use shop towels to cover plastic parts and coated surfaces to avoid damage.

INSPECTION

Inspect the brake pads and brake disk.

Measure the brake disk thickness.

Service Limit: 3.0 mm replace if below

Visually check the brake pad thickness and it should not exceed the wear indicator mark.

DISASSEMBLY

Remove two brake pads dowel pins and three bolts from the brake caliper.

Remove the brake pads.

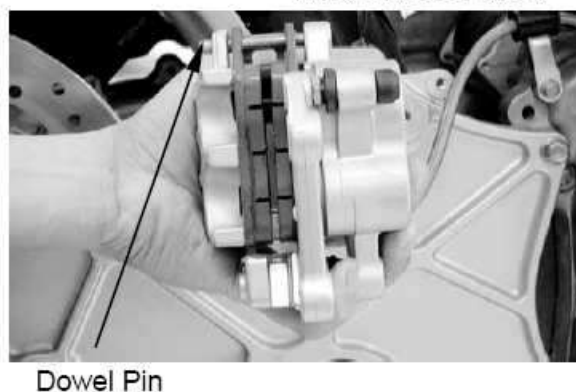
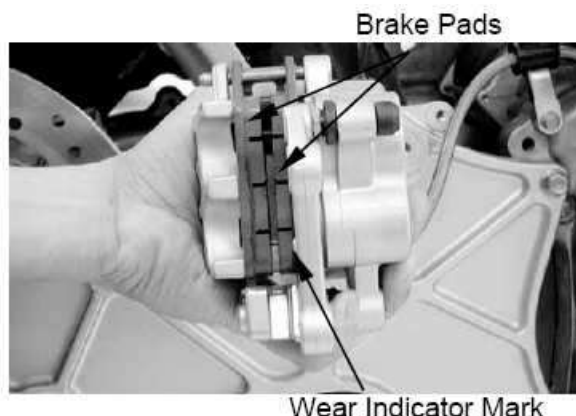
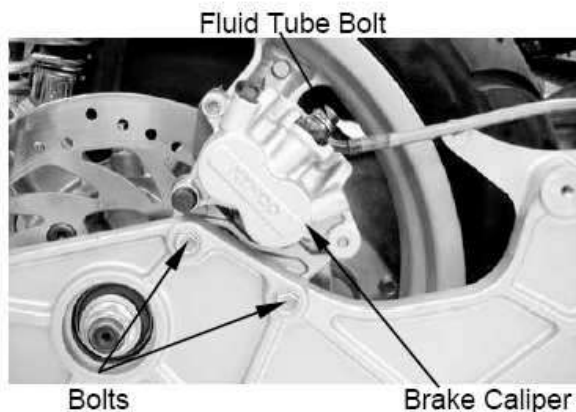

15. REAR WHEEL/REAR BRAKE/REAR SHOCK ABSORBER

LIKE 200i

Remove the piston from the brake caliper. If necessary, use compressed air to squeeze out the piston through the brake fluid inlet opening and place a towel under the caliper to avoid contamination caused by the removed piston.

Check the piston cylinder for scratches or wear and replace if necessary.

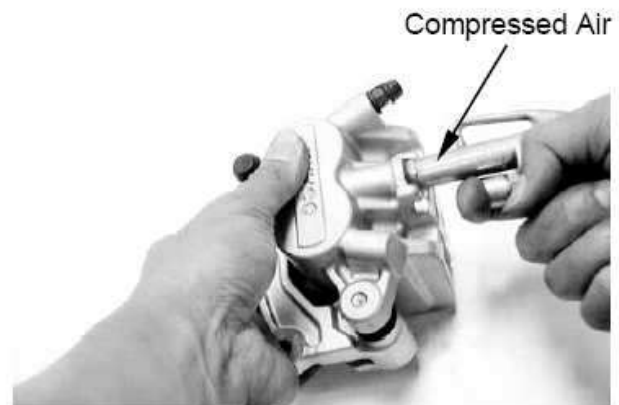

Push the piston oil seal outward to remove it. Clean the oil seal groove with brake fluid.

* Be careful not to damage the piston surface.



Check the piston for scratches or wear.

Measure the piston O.D. with a micrometer gauge.

Service Limit: 26.90 mm



Check the caliper cylinder for scratches or wear and measure the cylinder bore.

Service Limit: 27.05 mm



15. REAR WHEEL/REAR BRAKE/REAR SHOCK ABSORBER

LIKE 200i

ASSEMBLY

Clean all removed parts.

Apply silicon grease to the piston and oil seal.
Lubricate the brake caliper cylinder inside wall with brake fluid.

Install the brake caliper piston with grooved side facing out.

* Install the piston with its outer end protruding 3~5mm beyond the brake caliper.

Install the two spring plates onto the groove of the caliper.

* Make sure the spring plate next to the brake pad dowel pin orientation.

Install two brake pads and brake pad dowel pin.

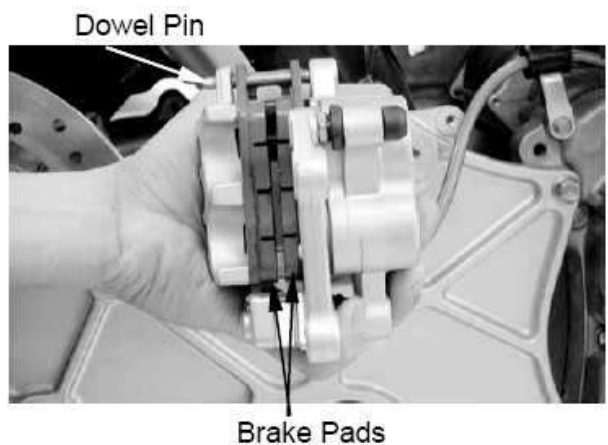
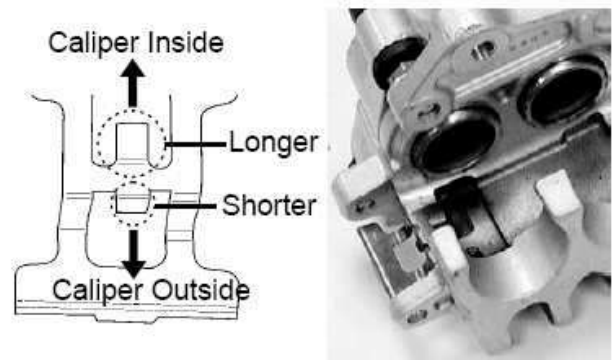
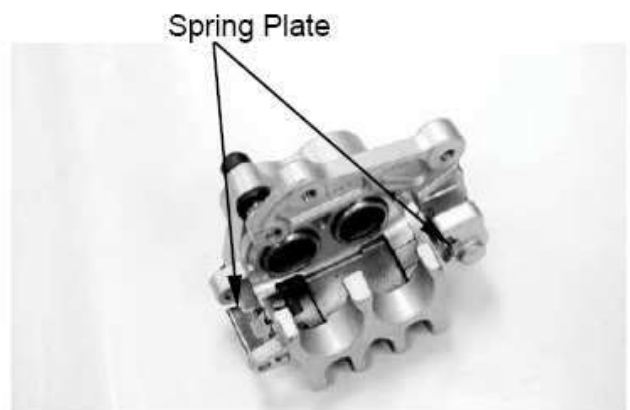

15. REAR WHEEL/REAR BRAKE/REAR SHOCK ABSORBER

LIKE 200i

INSTALLATION

Install the brake caliper to the rear fork and tighten the two bolts.

Torque: 27 N-m

Connect the brake fluid tube to the brake caliper and install fluid tube bolt, copper washers and tighten the fluid tube bolt.

Fill the brake reservoir with the specified brake fluid and bleed air from the brake system.

* When installing the brake fluid tube, be sure to install the two copper sealing washers.

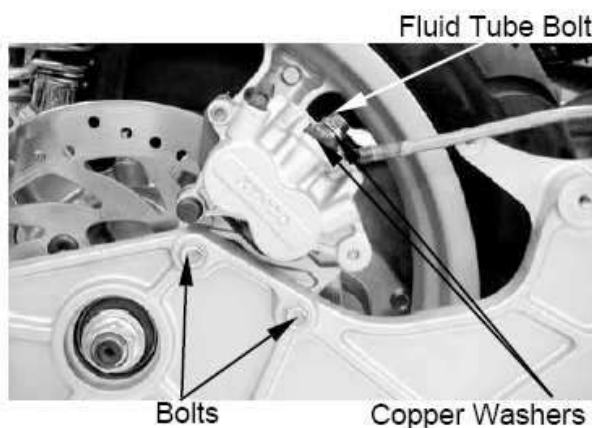

REAR FORK

REMOVAL

Remove the exhaust muffler.
Remove the rear brake caliper.

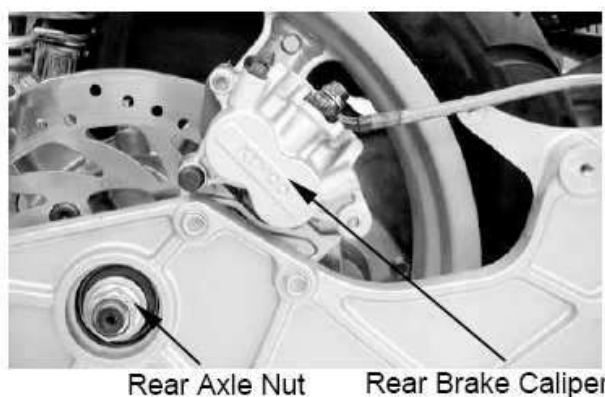

Remove the right rear shock absorber lower mount bolt.
Remove the rear axle nut and remove the collar.
Remove the rear fork.

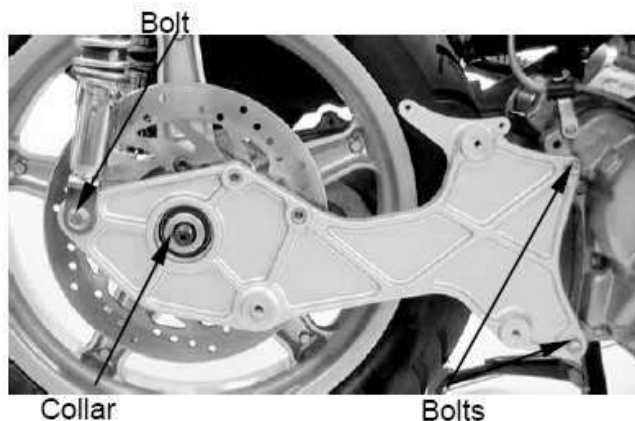

The installation sequence is the reverse of removal.

Turn the inner race of each bearing with your finger to see if they turn smoothly and quietly. Also check if the outer race fits tightly in the hub.

Replace the bearings if the races do not turn smoothly, quietly, or if they fit loosely in the hub.



15. REAR WHEEL/REAR BRAKE/REAR SHOCK ABSORBER

LIKE 200i

REAR WHEEL

REMOVAL

- Remove the exhaust muffler.
- Remove the rear brake caliper.
- Remove the rear fork.
- Remove the rear axle collar.
- Remove the rear wheel.



Rear Brake Disk

Rear Axle Collar

INSPECTION

Measure the rear wheel rim runout.

Service Limits:

- Radial: 2.0mm replace if over
- Axial: 2.0mm replace if over

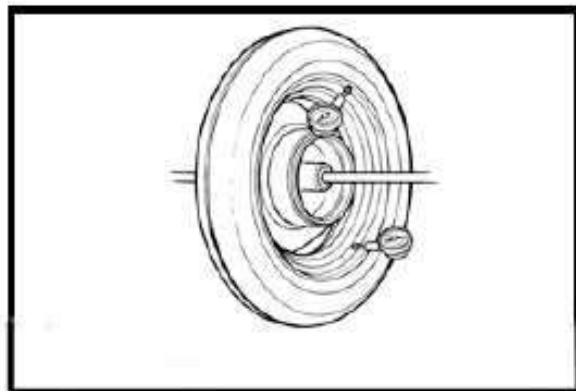

INSTALLATION

The installation sequence is the reverse of removal.

Torque:

- Rear shock absorber lower mount bolt: 35~45N-m
- Rear axle nut: 120 N-m

15. REAR WHEEL/REAR BRAKE/REAR SHOCK ABSORBER

LIKE 200i

REAR SHOCK ABSORBER

REMOVAL

Remove the front cover.
Remove the met-in box.
Remove the air cleaner case.
Remove the rear shock absorber upper and lower mount bolts to remove the rear shock absorber.

Upper Mount Bolt



Lower Mount Bolt

INSTALLATION

Install the rear shock absorber.
Install the rear shock absorber upper mount bolt and then install the lower mount bolt.

Torque:

Upper Mount Bolt: 3.5~4.5kg-m

Lower Mount Bolt: 2.4~3.0kg-m

Install the frame body cover.

Rear Shock Absorber



ELECTRICAL EQUIPMENT

SERVICE INFORMATION.....	16- 1
TROUBLESHOOTING.....	16- 2
CHARGING SYSTEM.....	16- 3
BATTERY	16- 4
IGNITION SYSTEM	16- 7
STARTING SYSTEM.....	16- 11

SERVICE INFORMATION

GENERAL INSTRUCTIONS

CHARGING SYSTEM

- The battery can be charged and discharged repeatedly. If a discharged battery is not used for a long time, its service life will be shortened. Generally, the capacity of a battery will decrease after it is used for 2~3 years. A capacity-decreased battery will resume its voltage after it is recharged but its voltage decreases suddenly and then increases when a load is added.
- When a battery is overcharged, some symptoms can be found. If there is a short circuit inside the

battery, no voltage is produced on the battery terminals. If the rectifier won't operate, the voltage will become too high and shorten the battery service life.

- If a battery is not used for a long time, it will discharge by itself and should be recharged every 3

months.

- A new battery filled with electrolyte will generate voltage within a certain time and it should be recharged when the capacity is insufficient. Recharging a new battery will prolong its service life.
- Inspect the charging system according to the sequence specified in the Troubleshooting.
- Do not disconnect and soon reconnect the power of any electrical equipment because the electronic parts in the regulator/rectifier will be damaged. Turn off the ignition switch before operation.
- It is not necessary to check the MF battery electrolyte or fill with distilled water.
- Check the load of the whole charging system.
- Do not quick charge the battery. Quick charging should only be done in an emergency.
- Remove the battery from the motorcycle for charging.
- When replacing the battery, do not use a traditional battery.
- When charging, check the voltage with an electric tester.

IGNITION SYSTEM

- Some electrical components may be damaged if terminals or connectors are connected or disconnected while the ignition switch is "ON" and current is present.
- When servicing the ignition system, always follow the steps in the troubleshooting on page 18-2.
- The ignition timing cannot be adjusted since the ignition control module is already adjusted in factory.
- The ignition control module or ECU maybe damaged if dropped or the connector is disconnected

when the key is ON, the excessive voltage may damage the ignition control module or ECU. Always turn off the ignition switch before servicing.

- A faulty ignition system is often related to poor connections. Check those connections before proceeding.
- Make sure the battery is adequately charged. Using the starter motor with weak battery results in

a slower engine cranking speed as well as no spark at the spark plug.

- Use a spark plug of the correct heat range. Using spark plug with an incorrect heat range can damage the engine.

STARTING SYSTEM

- The removal of starter motor can be accomplished with the engine installed.
- For the starter clutch removal, refer to page 10-3.
- After the starter clutch is installed, be sure to add the engine oil and coolant and then bleed air from the cooling system.

TROUBLESHOOTING

CHARGING SYSTEM

No power

- Dead battery
- Disconnected battery cable
- Fuse burned out
- Faulty ignition switch ignition system

Low power

- Weak battery
- Loose battery connection connector
- Charging system failure
- Faulty regulator/rectifier

Intermittent power

- Loose battery cable connection
- Loose charging system connection
- Loose connection or short circuit in

Charging system failure

- Loose, broken or shorted wire or
- Faulty regulator/rectifier
- Faulty A.C. generator

IGNITION SYSTEM

No peak voltage

- Short circuit in engine stop switch or ignition switch wire.
- Faulty engine stop switch or ignition switch.
- Loose or poorly connected ignition control module connectors.
- Open circuit or poor connection in ground wire of the ignition control module.
- Faulty crank position sensor.
- Faulty ignition control module.

Peak voltage is normal, but no spark jumps at the plug

- Faulty spark plug or leaking ignition coil secondary current.
- Faulty ignition coil.

STARTING SYSTEM

Starter motor won't turn

- Fuse burned out
- Weak battery
- Faulty ignition switch
- Faulty starter clutch or gear
- Faulty front or rear stop switch
- Faulty starter relay
- Poorly connected, broken or shorted wire
- Faulty starter motor
- Starter motor rotates reversely
- Weak battery

Lack of power

- Weak battery
- Loosed wire or connection
- Foreign matter stuck in starter motor

Starter motor rotates but engine does not start

- Faulty starter pinion

CHARGING SYSTEM

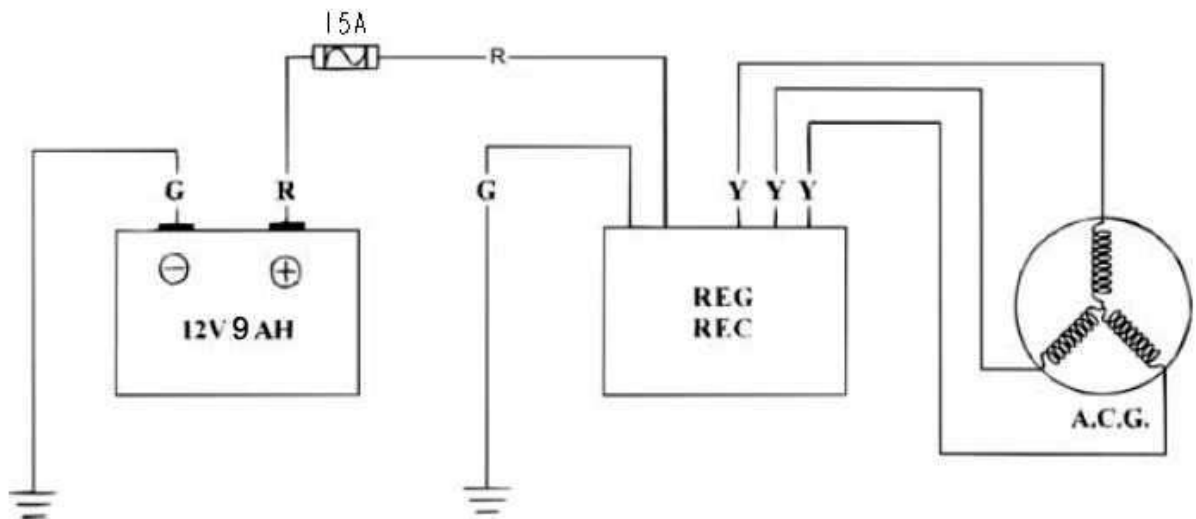
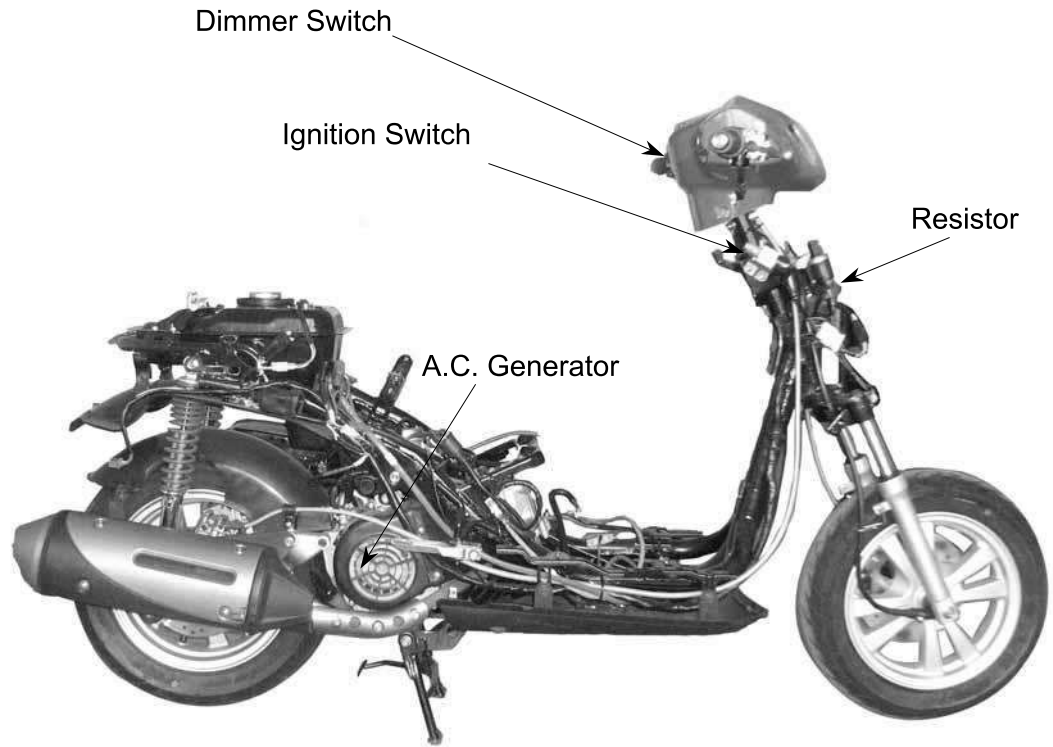

BATTERY REMOVAL

Remove the battery cover.
Disconnect the battery cables .

- * First disconnect the battery negative (-) cable and then the positive (+) cable.

Remove the battery.
The installation sequence is the reverse of removal.

BATTERY CHARGING (OPEN CIRCUIT VOLTAGE) INSPECTION

Remove the battery cover and disconnect the battery cables.
Measure the voltage between the battery terminals.
Fully charged : 13.0V~13.2V
Undercharged : 12.3V max.

- * Battery charging inspection must be performed with an electric tester.

CHARGING METHOD

Connect the charger positive (+) cable to the battery positive (+) cable.
Connect the charger negative (-) cable to the battery negative (-) cable.

- *
 - Keep flames and sparks away from a charging battery.
 - Turn power ON/OFF at the charger, not at the battery terminals to prevent sparks near the battery.
 - Charge the battery according to the current specified on the battery surface.

Charging current: Standard: 0.4A
Quick : 4A
Charging time : Standard: 5 hours
Quick : 0.5 HOUR
After charging: Open circuit voltage: 12.8V min.

- *
 - Quick charging should only be done in an emergency.
 - During quick charging, the battery temperature should not exceed 45°C .
 - Measure the voltage 30 minutes after the battery is charged.



Battery Cover

PERFORMANCE TEST

Warm up the engine.
Remove the floor mat and front tool box cover.

* Use a fully charged battery to check the charging system output.

Stop the engine and open the fuse box. Disconnect the wire lead from the fuse terminal. Connect an ammeter between the wire lead and fuse terminal as shown. Connect the battery positive (+) terminal to the voltmeter positive (+) probe and battery negative (-) terminal to the voltmeter negative (-) probe.

Start the engine, gradually increase engine speed to test the output:

Position \ RPM	Day	Night
2500	1.3A min.	1.0A min.
6000	2.0A min.	2.0A min.

Charging Limit Voltage: $14.5 \pm 0.5V/8000rpm$
If the limit voltage is not within the specified range, check the regulator/ rectifier.

A.C. GENERATOR INSPECTION

* This test can be made without removing the stator from the engine. Disconnect the yellow wire from the auto-bystarter.

Remove the met-in box.
Disconnect the A.C. generator connector.
Check the continuity between the yellow wires and ground.
There should be continuity between the yellow wires and no continuity between each yellow wire and ground.

Resistance:

Yellow ~ Yellow	1 ~ 2.5Ω
-----------------	----------

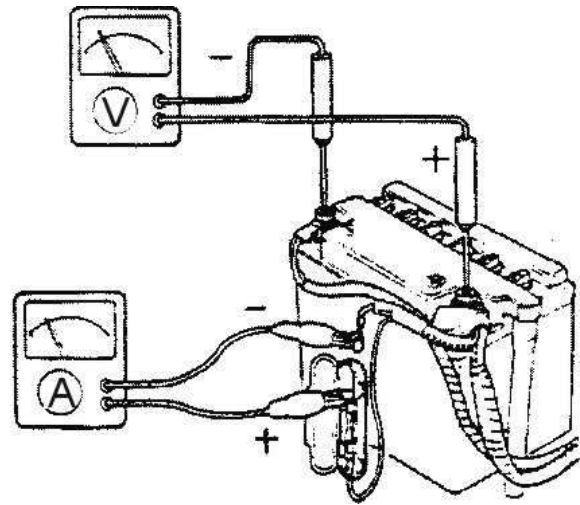

A.C. Generator Connector



A.C. GENERATOR REMOVAL

- A.C. generator removal
- A.C. generator installation

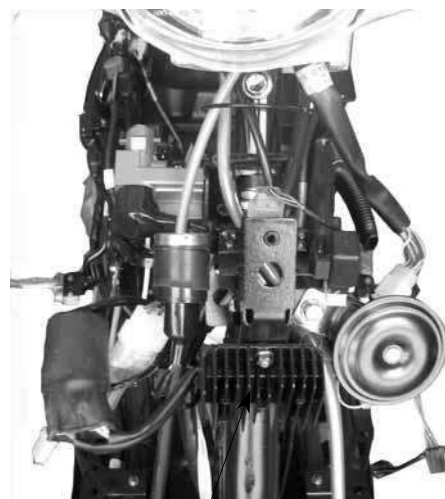
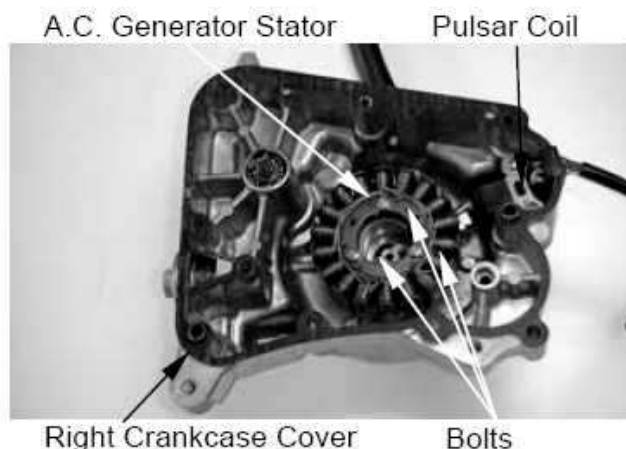

Regulator/Rectifier

REGULATOR/RECTIFIER

INSPECTION

Remove the met-in box.
 Remove the regulator/rectifier wire coupler.
 Check the continuity between the wire terminals.

Normal Direction: Continuity

	(+) Probe	(-) Probe
I	Yellow	Green
II	Red	Yellow

Reverse Direction: No Continuity

	(+) Probe	(-) Probe
I	Green	Yellow
II	Yellow	Red

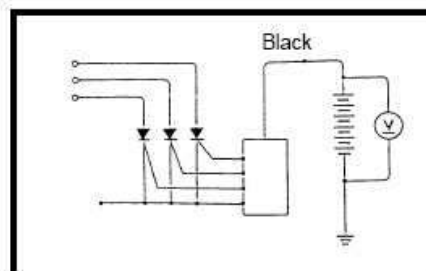
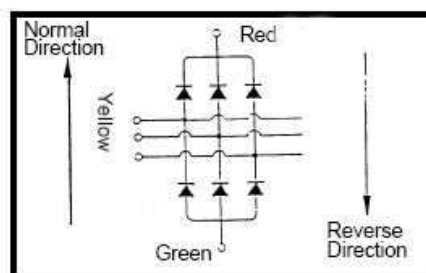

VOLTAGE REGULATION TEST

Connect a voltmeter across the battery terminals.
 Start the engine and gradually increase the engine speed to 5000 rpm.
 The battery terminal voltage should be within 14.0~15.0V.

IGNITION SYSTEM

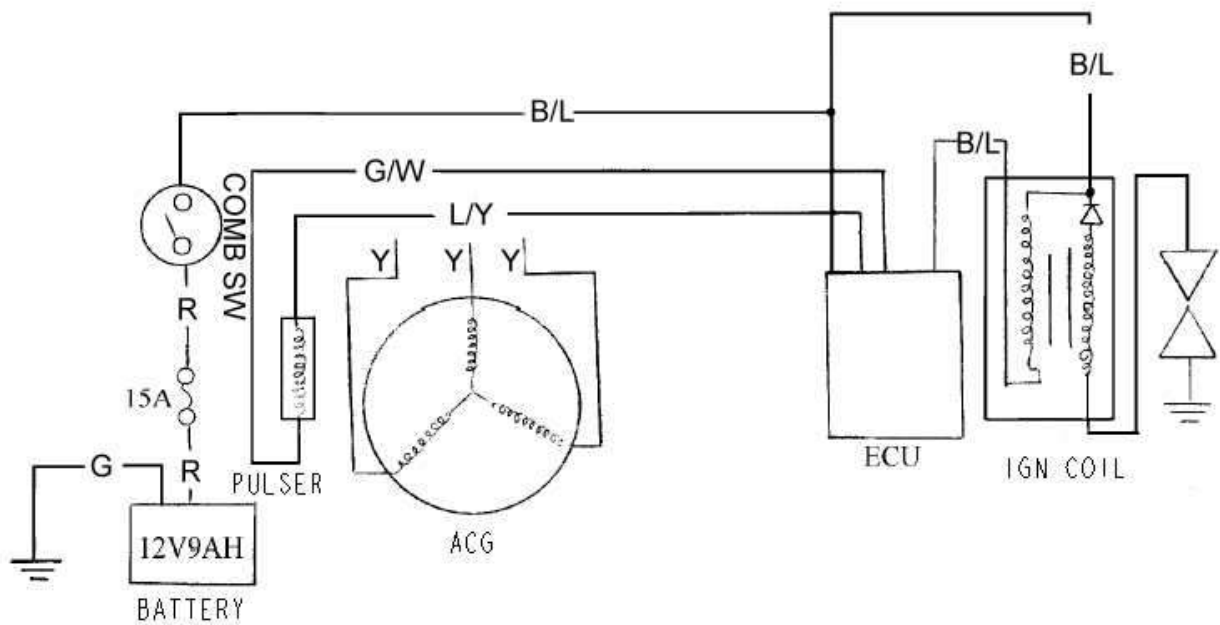
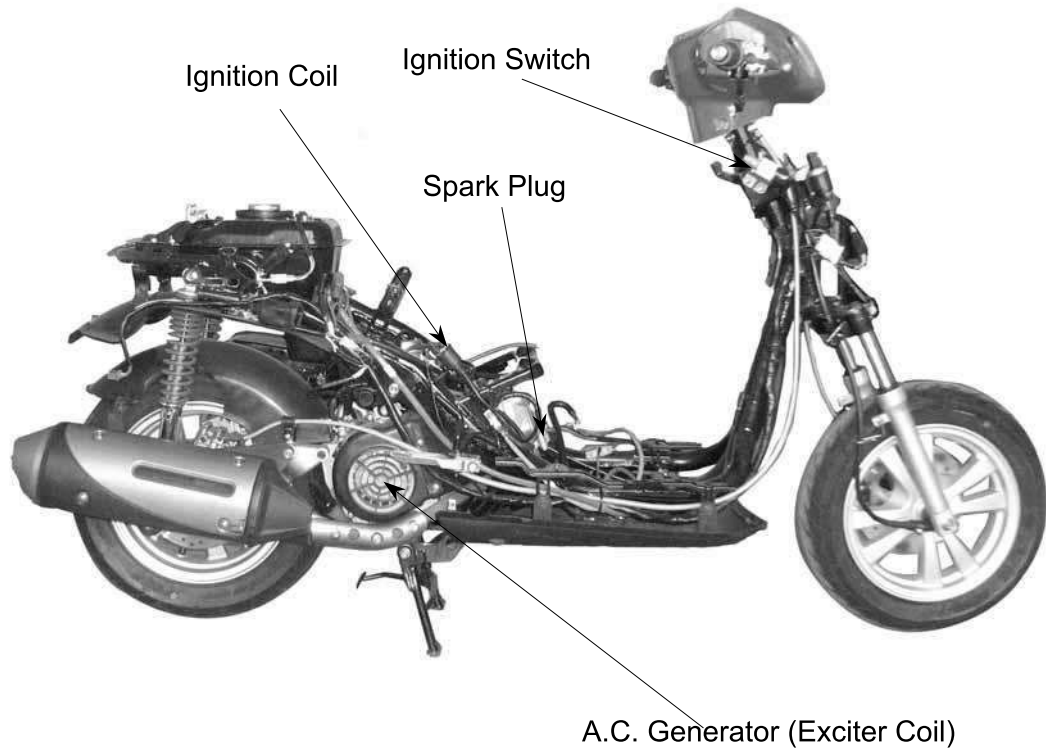

IGNITION COIL INSPECTION

Remove the seat and met-in box.
Remove the ignition coil.

IGNITION COIL CONTINUITY TEST

Inspect the continuity of the ignition coil, primary coil and secondary coil.

* This is a general test. Accurate ignition coil test must be performed with an ignition unit tester.

Measure the ignition coil resistances

0.55~0.85 Ω /20°C

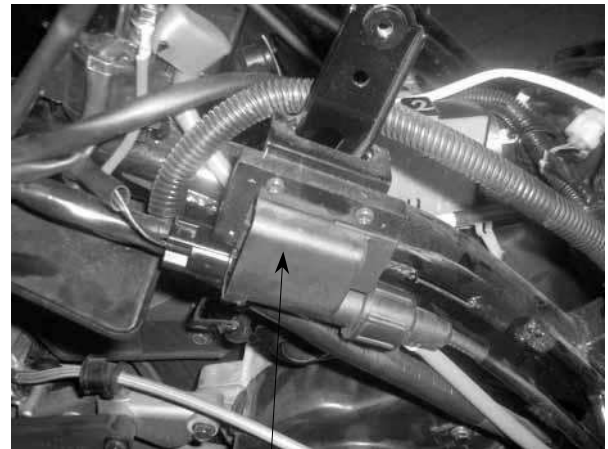

Ignition Coil



CRANK POSITION SENSOR INSPECTION

* This test is performed with the stator installed in the engine.

Remove the seat and met-in box.

Disconnect the Crank Position Sensor Wire Coupler.

Measure the resistance between the blue/yellow and green/white wire terminals.

Blue/Yellow ~ Green/White	115Ω±15Ω
---------------------------	----------



TILT SWITCH INSPECTION

Support the scooter level surface.

Put the side stand up and engine stop switch is at "RUN".

Turn the ignition switch to "OFF".

Remove the screws, washers and tilt switch.

* Do not disconnect the tilt switch connector during inspection. The capacity of battery must be fully charged.

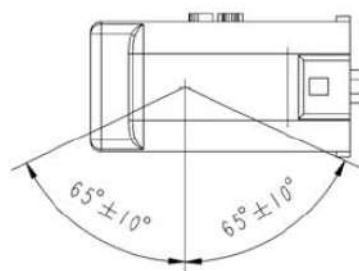
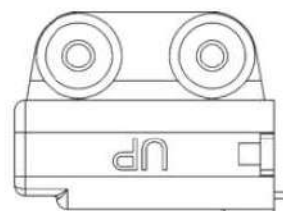

Place the tilt switch vertical as shown at the ignition switch "ON". Measure the voltage as below.

Terminal	Standard
V/R (+) – B/W (-)	5 V (ECU voltage)
V/G (+) – B/W (-)	0.4 ~ 1.4 V less

Incline the tilt switch 65±10 degrees to the left or right at the ignition switch "ON". Measure the voltage as below.

Terminal	Standard
V/R (+) – B/W (-)	5 V (ECU voltage)
V/G (+) – B/W (-)	3.7 ~ 4.4 V

If repeat this test, first turn the ignition switch to "OFF", then turn the ignition switch to "ON".

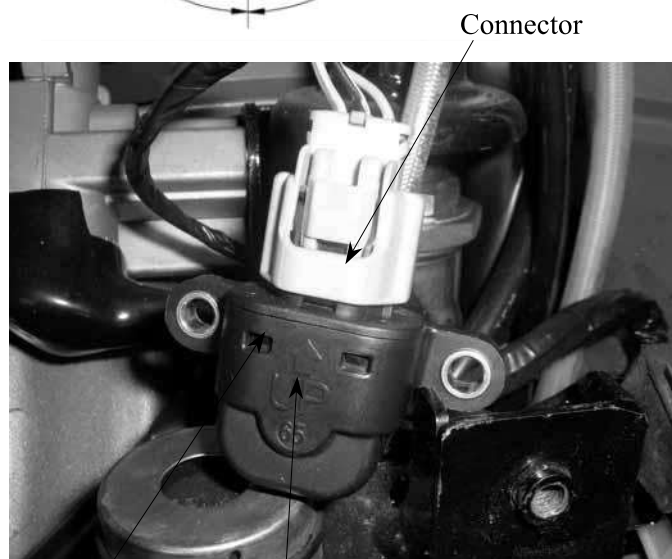

Tilt Switch "UP" Mark

REMOVAL/INSTALLATION

Disconnect the connector and remove two screws, then remove tilt switch.

Installation is in the reverse order of removal.

* Install the tilt switch with its "up" mark facing up.

Tighten the mounting screws securely.



Screws

STARTING SYSTEM

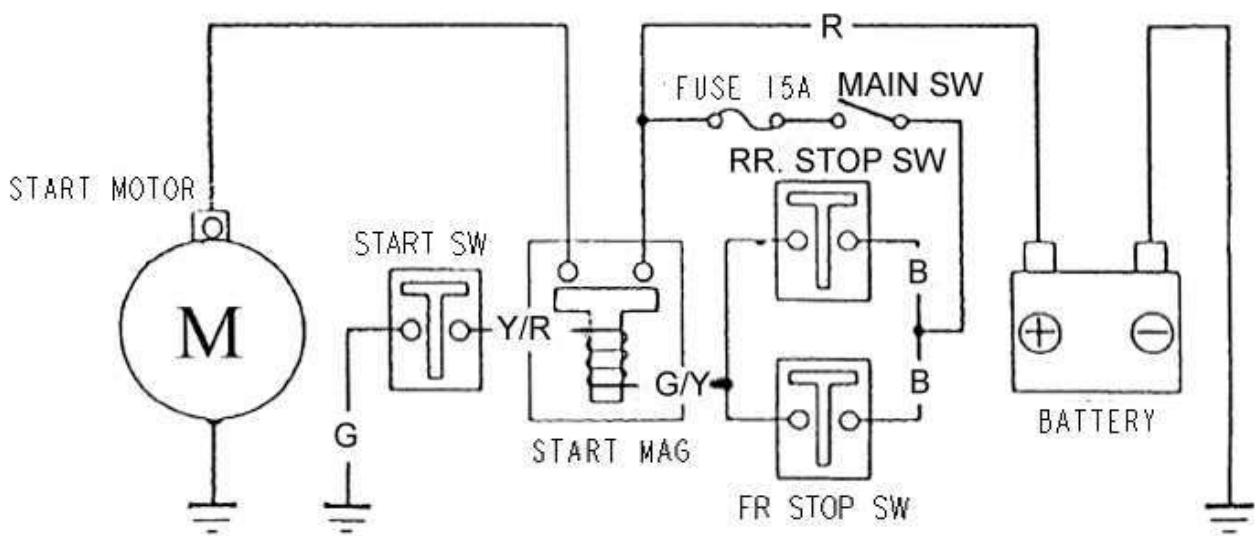
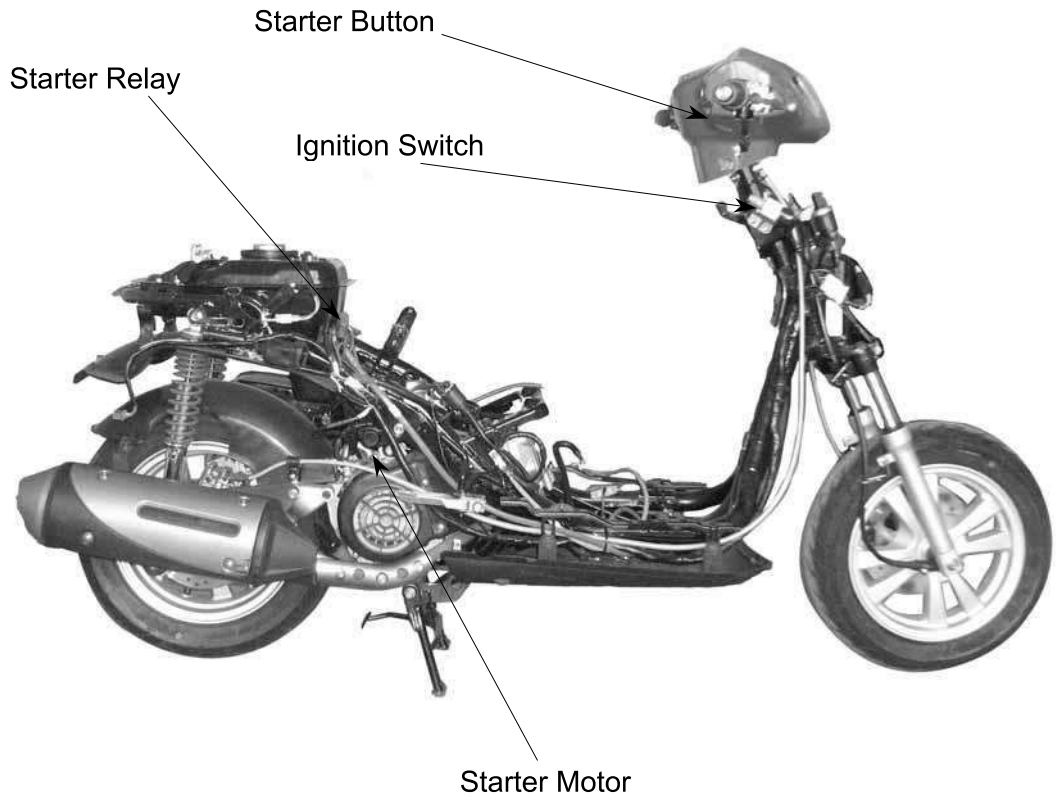

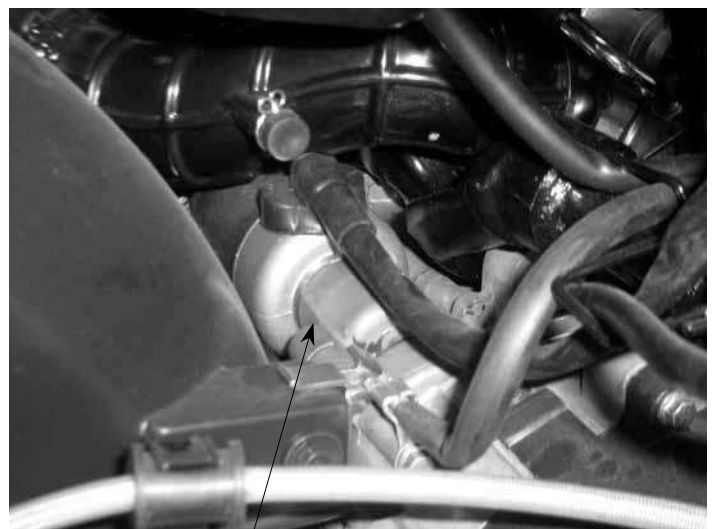
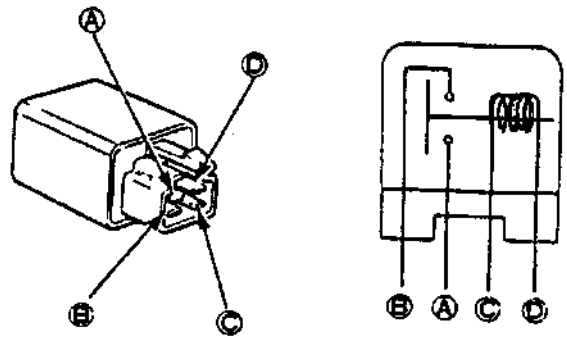

r

DISASSEMBLY

Remove two starter motor case screws, front cover, rear cover, motor case and other parts.

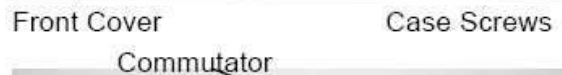

INSPECTION

Inspect the removed parts for wear, damage or discoloration. Replace if necessary. Clean the commutator if there is metal powder between the segments.



Check for continuity between pairs of the commutator segments and there should be continuity.

Also, make a continuity check between individual commutator segments and the armature shaft. There should be no continuity.

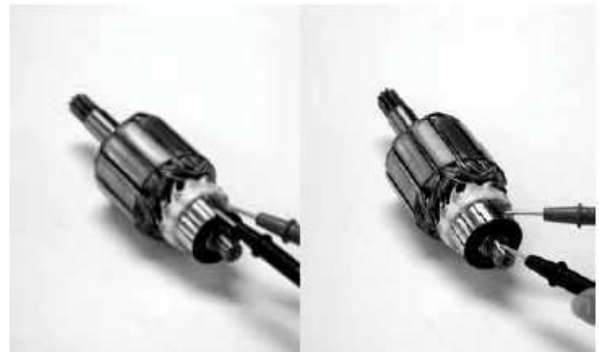

STARTER MOTOR CASE CONTINUITY CHECK

Check to confirm that there is no continuity between the starter motor wire terminal and the motor front cover.

Also check for the continuity between the wire terminal and each brush. Replace if necessary.



Wire Terminal

Measure the length of the brushes.

Service Limit: 8.5 mm replace if below



Check for continuity between the brushes. If there is continuity, replace with new ones.



Check if the needle bearing in the front cover turns freely and has no excessive play. Replace a new one if any abnormal. Check the dust seal for wear or damage.

Bushing



Dust Seal

ASSEMBLY

Apply grease to the dust seal in the front cover.

Install the brushes onto the brush holders.

Apply a thin coat of grease to the two ends of the armature shaft.

Insert the commutator into the front cover.



Motor Case

Install a new O-ring to the front cover.
Install the starter motor case, aligning the tab on the motor case with the groove on the front cover.
Tighten the starter motor case screws.



O-ring Motor Case
Starter Motor Cable

INSTALLATION

Connect the starter motor cable.
Check the O-ring for wear or damage and replace if necessary.
Apply grease to the O-ring and install it to the starter motor.
Tighten the two mounting bolts.



O-ring

INSTRUMENT/SWITCHES/LIGHTS

SERVICE INFORMATION	17-1
TROUBLESHOOTING.....	17-1
FUEL UNIT	17-2
SWITCHES.....	17-4
STOP SWITCH INSPECTION/HORN	17-6
FRONT TURN SIGNAL LIGHT REPLACEMENT	17-7
INSTRUMENT/HEADLIGHT.....	17-8

SERVICE INFORMATION

GENERAL INSTRUCTIONS

- Wires should be connected to other wires of the same color. Couplers must be connected to other couplers of the same color.
- All plastic plugs have locking tabs that must be released before disconnecting, and must be aligned when reconnecting.
- After installation of each switch, a continuity check must be performed.

TROUBLESHOOTING

Lights do not come on when ignition switch is "ON"

- Burned bulb
- Faulty switch
- Broken or shorted wire
- Fuse burned out
- Weak battery
- Poorly connected wire
- Faulty winker

Light dims

- Faulty ignition coil
- Wire or switch resistance too high
- Faulty regulator/rectifier

Headlight does not change when dimmer switch is turn to Hi or Lo

- Faulty or burned bulb
- Faulty dimmer switch

Motor oil indicator light does not come on (when motor oil is insufficient)

- Fuse burned out
- Dead battery
- Faulty ignition switch
- Faulty instrument
- Faulty oil meter

Motor oil indicator light winks

- Loose wire connection
- Broken wire
- Faulty oil meter

Fuel gauge pointer does not register correctly

- Disconnected wire or connector
- Broken wire
- Faulty float
- Faulty fuel unit
- Faulty instrument

Fuel gauge pointer fluctuates or swings

- Loose wire connection
- Faulty fuel unit
- Faulty instrument

FUEL UNIT

* No Smoking!

REMOVAL

Remove the seat.
Remove the body cover.
Disconnect the fuel unit wire connectors.

* Do not damage the fuel unit wire.

Remove the fuel unit.

* Be careful not to bend or damage the fuel unit float arm.

INSPECTION

Remove the fuel unit.
Measure the resistance between the fuel unit wire terminals with the float at upper and lower positions.

RESISTANCES Unit: Ω

Wire Terminals	Upper	Lower
G~Y/W	20~40	560~580

Fuel Unit Wire

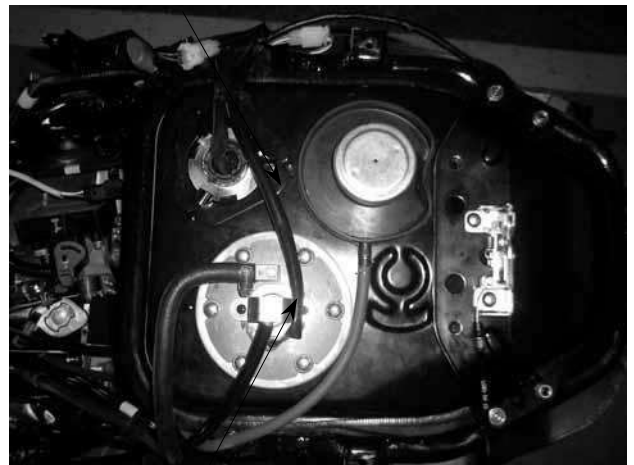

Fuel Unit



FUEL GAUGE INSPECTION

Connect the fuel unit wire connectors and turn the ignition switch "ON".

* Before performing the following test, operate the turn signals to determine that the battery circuit is normal.

Check the fuel gauge needle for correct indication by moving the fuel unit float up and down.

Float Position	Needle Position
Upper	"F" (Full)
Lower	"E" (Empty)

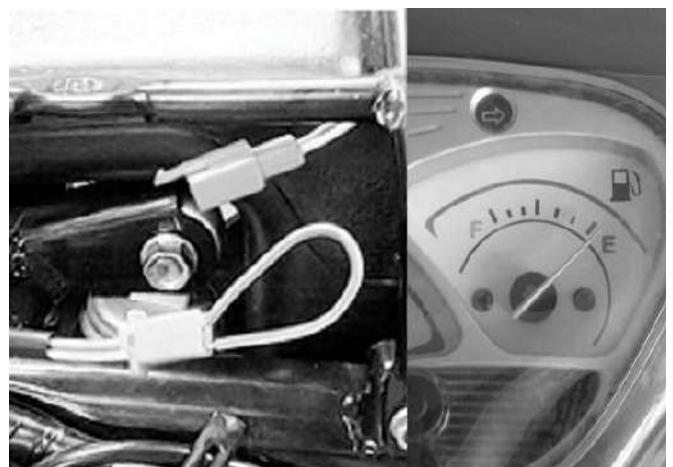

Wire Connector

INSTALLATION

The installation sequence is the reverse of removal.

- *
 - Install the fuel unit at the connect position.

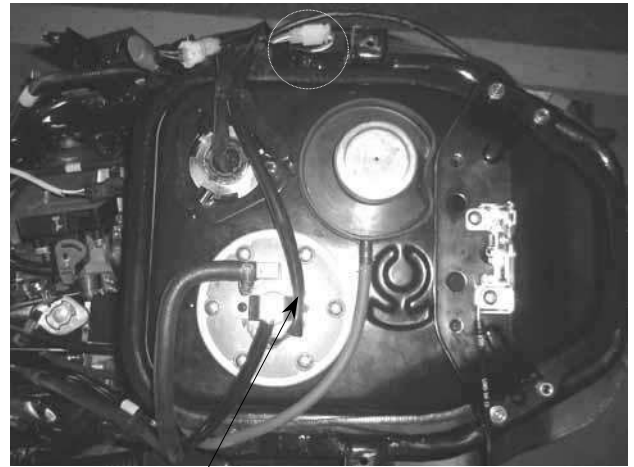

Fuel Unit

SWITCHES

IGNITION SWITCH INSPECTION

Remove the front cover. (⇒12)
 Disconnect the ignition switch wire couplers and check for continuity between the wire terminals.

Color	Red	Black/White	Green	Black
Symbol	BAT1	IG	E	BAT2
LOCK		○ — ○	○	
OFF		○ — ○	○	
ON	○			○



IGNITION SWITCH REPLACEMENT

Remove the front cover. (⇒12)
 Disconnect the ignition switch wire couplers.

Remove the two mounting bolts and remove the ignition switch.
 The installation sequence is the reverse of removal.

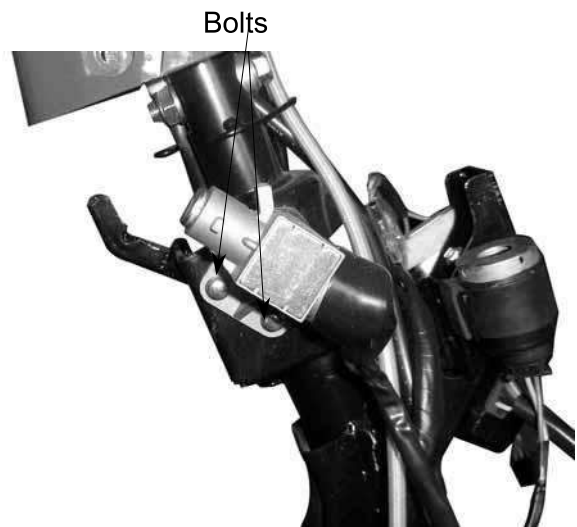

DIMMER SWITCH INSPECTION

Check for continuity between wire terminals.

Color	W/L	L	We	Y
Symbol	HL	HI	LO	BAT
HI	○	○		
LO	○		○	
PASSING		○		○



TURN SIGNAL SWITCH INSPECTION

Check for continuity between the wire terminals.

Color	SB	O	GR
Symbol	R	L	WR
R	○		○
L		○	○



STARTER SWITCH INSPECTION

Check for continuity between wire terminals.

Push the starter button when measuring.

Color	Y/R	G
Symbol	ST	E
FREE		
PUSH	⊖	○



Starter Switch

HORN SWITCH INSPECTION

Check for continuity between wire terminals.

Push the horn button when measuring.

Color	Light Green	Brown / Blue
Symbol	HO	BAT
FREE		
PUSH	○	○



Horn Switch

Stop Switch Wire

STOP SWITCH INSPECTION

Remove the handlebar front cover.
 Disconnect the front and rear stop switch wire couplers.
 Check for continuity between the wire terminals when the front/rear brake lever is applied.



HORN INSPECTION

Remove the frame front cover.
Disconnect the horn wire couplers. The horn is normal if it sounds when a 12V battery is connected across the horn wire terminals.



FRONT TURN SIGNAL LIGHT REPLACEMENT

Remove three screws attaching the turn signal light set and remove the light set.

* Replace with new set of the same specifications.

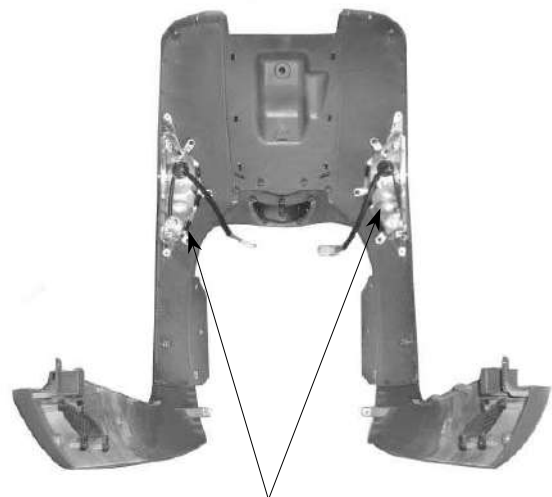

Turn Signal Light Set

TAILLIGHT/STOPLIGHT/REAR TURN SIGNAL LIGHT BULB REPLACEMENT

Taillight Base Removal:
Remove the rear protective cover.
Remove the seat.
Remove the body cover.
Remove the taillight base.
The installation sequence is the reverse of remove.



Taillight Base

INSTRUMENTS

BULB REPLACEMENT

Remove the handlebar rear cover.
 Remove the bulb socket and replace the bulb.
 The installation sequence is the reverse of removal.

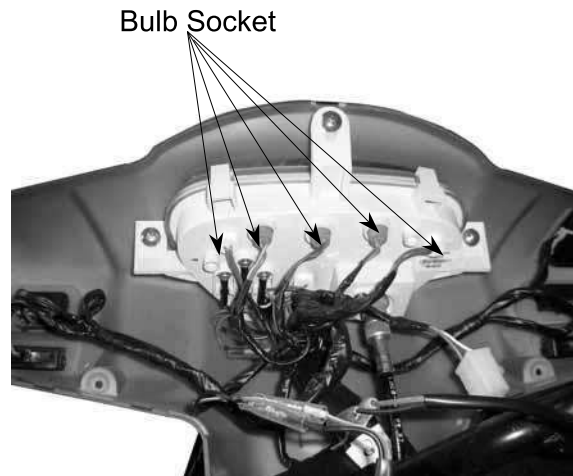

INSTRUMENTS REPLACEMENT

Remove the handlebar rear cover.
 Disconnect the right and left handlebar switches wire couplers.
 Disconnect the speedometer cable.
 Remove the instrument bulb sockets.
 Disconnect the two fuel gauge wires.
 Remove the instrument wire clamp screw.
 Remove the three screws attaching the instruments to the handlebar rear cover.
 Remove the instruments.

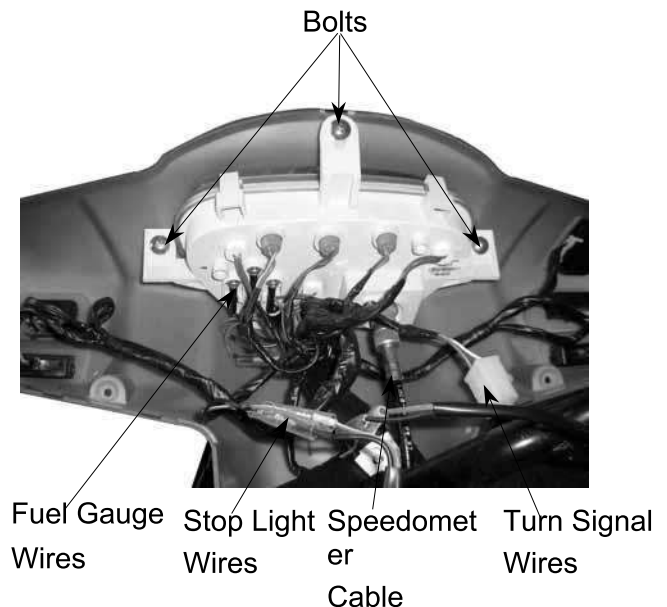

HEADLIGHT

REMOVAL/BULB REPLACEMENT

Remove the handlebar rear cover.
 Remove the bulb sockets and bulbs.

- *
- The model adopts krypton gas bulb. When installing, do not directly touch the bulb glass with fingers.
 - Use bulbs of the same specifications for replacement.

The installation sequence is the reverse of removal.

