

1. Quick Reference

This chapter provides a quick reference source of technical specifications and information for KYMCO XCITING S 400 model.

Component Location	1-2
Special Tools	1-5
Specifications	1-6
Torque Specifications	1-12
Troubleshooting	1-15
VIN and Engine Number Location	1-20

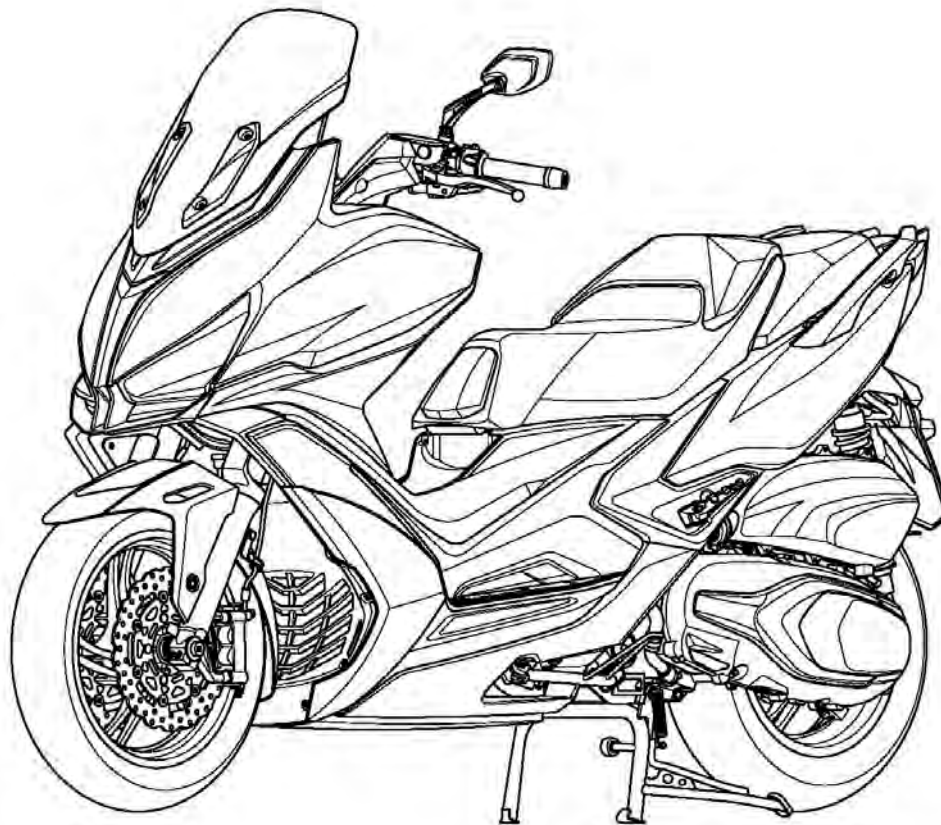

Component Location

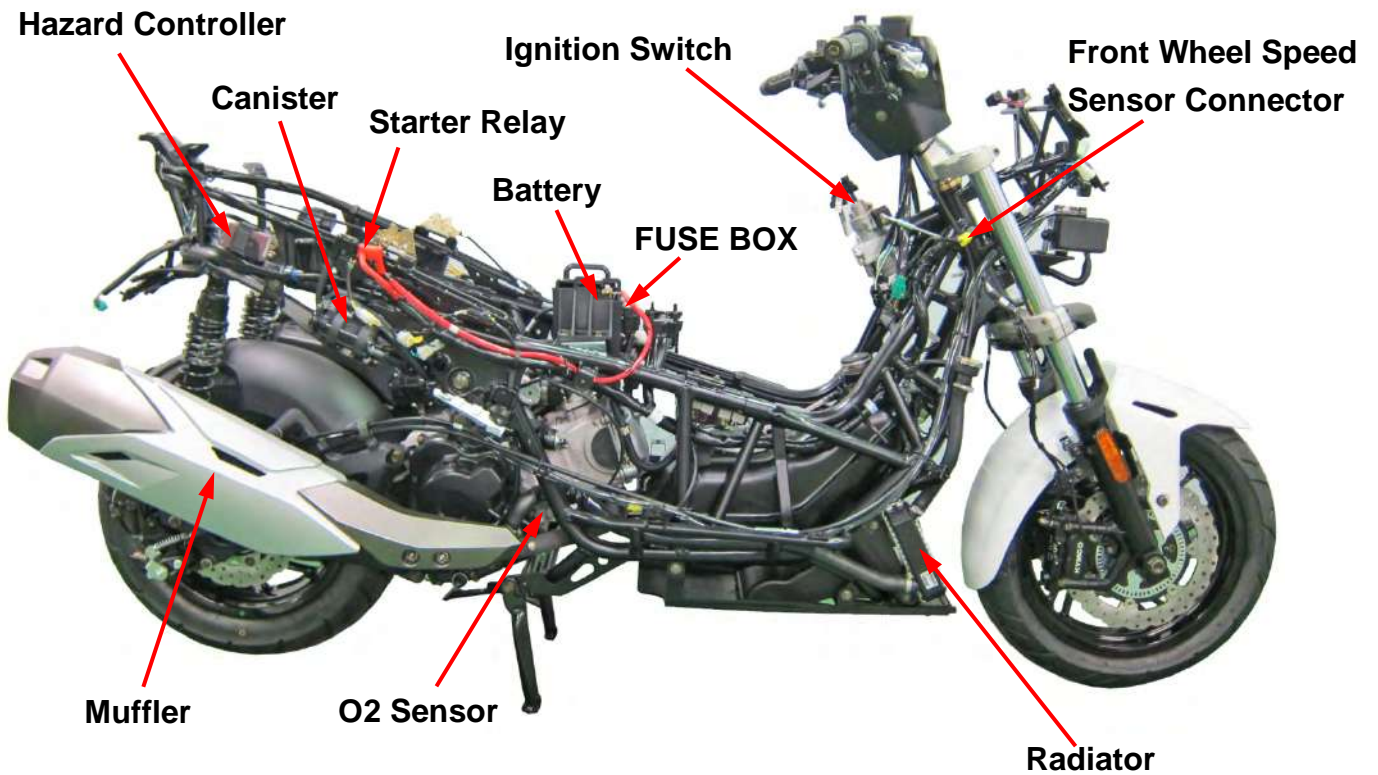
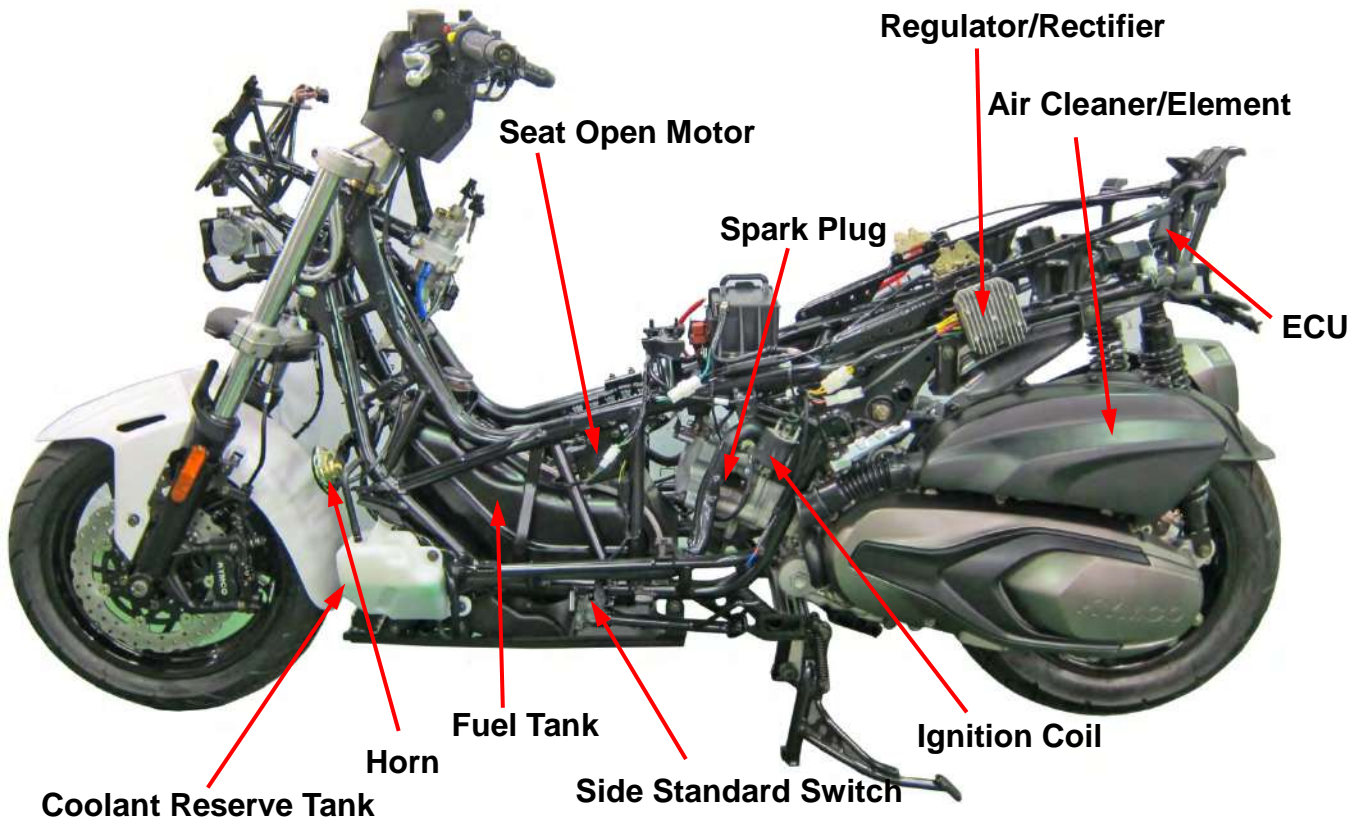

Component Location

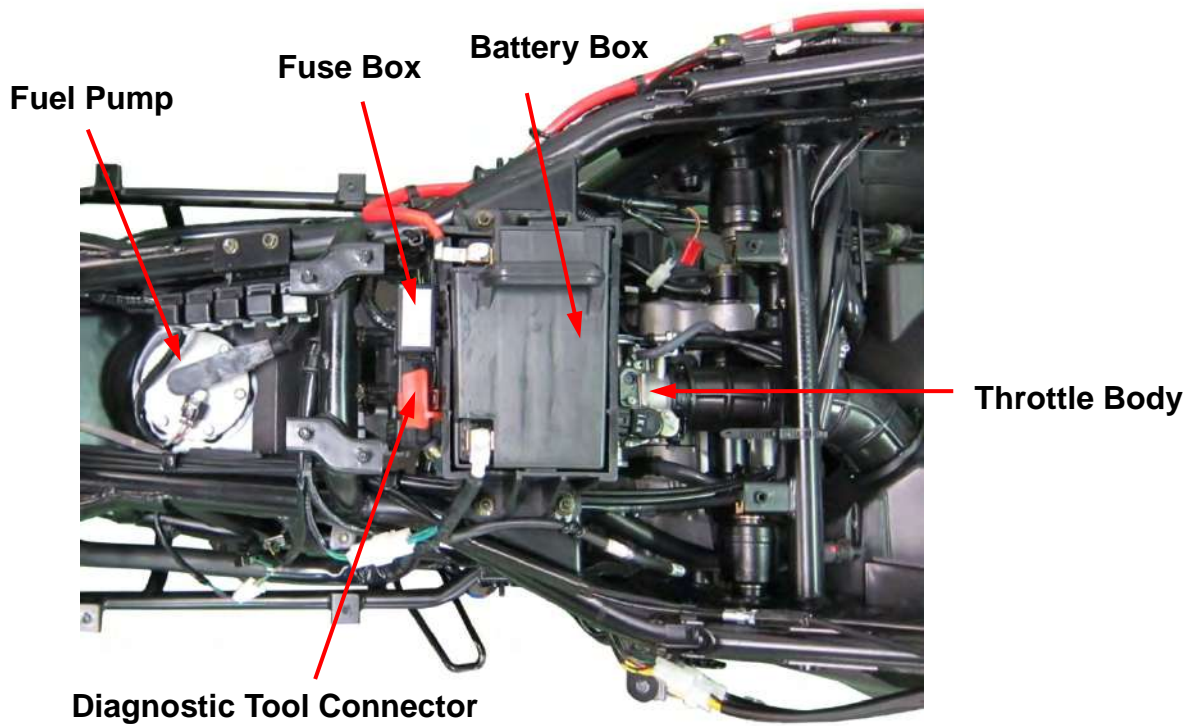
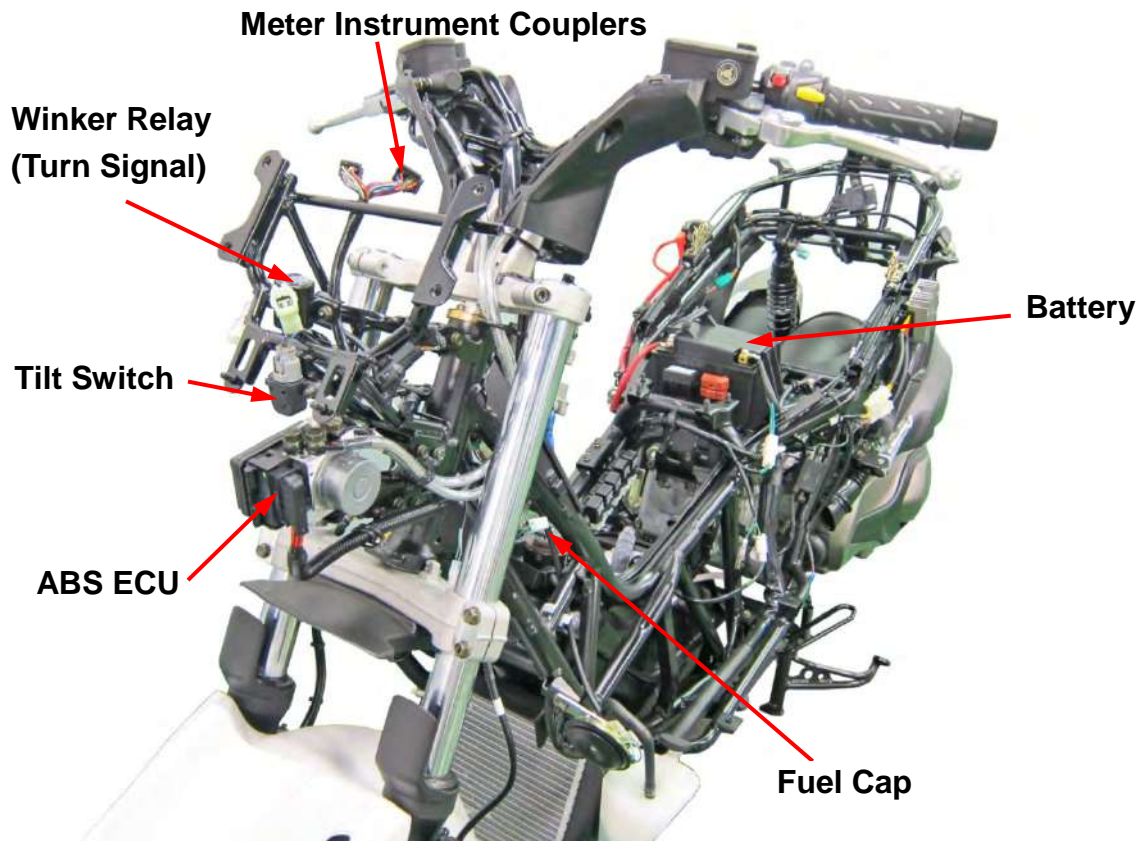

Component Location

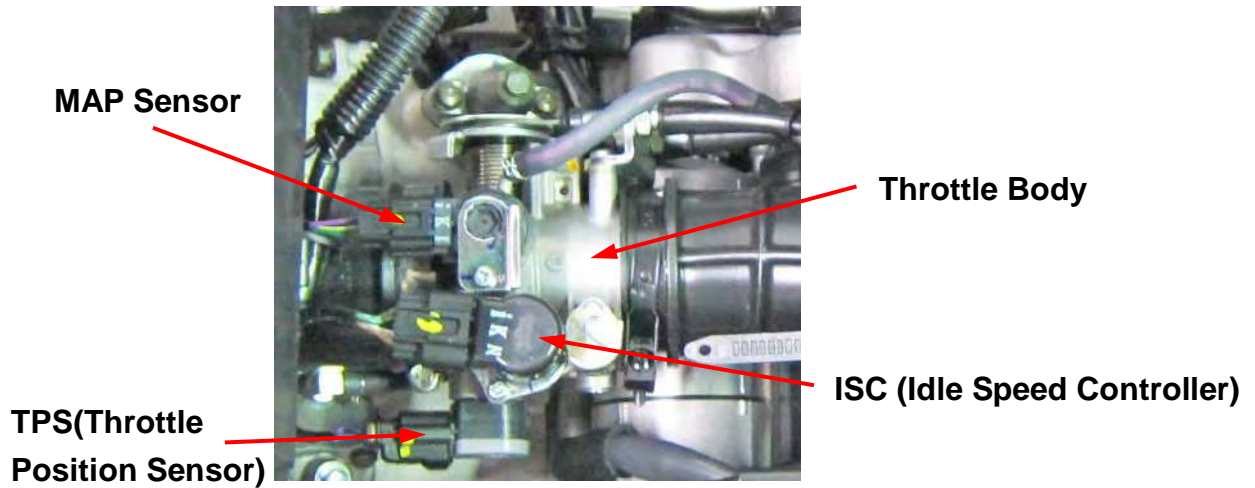

Seat Open Motor Relay/ Starter Relay/ Fuel Pump Relay/ ECU Relay/ Fan Relay
(The location refer to the wiring diagram wire color)

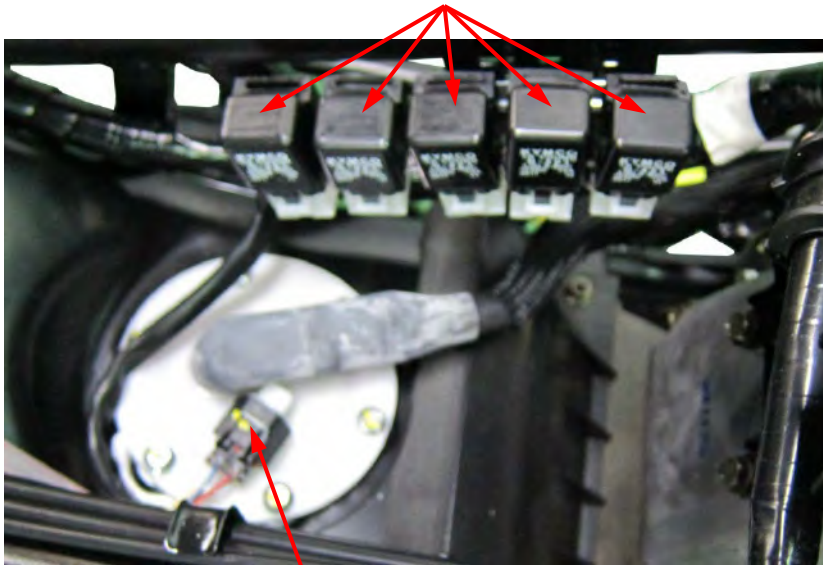

Fuel Pump

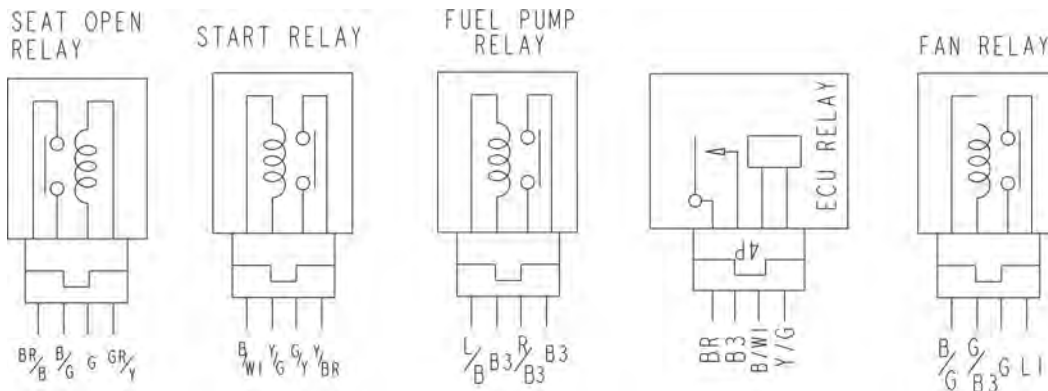

Special Tools

ITEM	TOOL NO	DESCRIPTION
Puller (M28x1) TAPPET ADJUSTER	A120E00036	Adjusting valve clearance
OIL SEAL & BEARING DRIVER	A120E00014	General Driver Set
UNIVERSAL HOLDER	A120E00021	Holding clutch pulley and flywheel
#41 NUT AND FITTING TOOL	A120E00028	Clutch disassembly
THREAD PROTECTOR	A120E00029	Crankshaft thread protector
CYLINDER COMPRESSION GAUGE	A120E00039	Engine cylinder compression measure
FUEL PRESSURE GAUGE	A120E00048	Fuel pump output pressure measure
VALVE COTTER INSTALLER	A120E00051	Valve cotter installation
CLUTCH SPRING COMPRESSOR	A120E00053	Clutch disassembly
BEARING PULLER	A120E00093	General Puller Set
VALVE CLEAN TOOL SET	A120E00096	Valve & Valve seat cleaning
FLYWHEEL PULLER	A120E00097	Flywheel removal
STEERING STEM LOCK NUT WRENCH (32mm)	A120F00002	Steering stem removal & installation
LOWER/UPPER OUTER RACE SEPARATOR	A120F00009	Lower/Upper outer race removal
LOWER/UPPER RACE REMOVER & INSTALLER	A120F00019	Lower/Upper outer race installation
STEERING STEM TOP THREAD WRENCH (46.5mm)	A120F00029	Steering stem removal & installation
PLIERS FUEL PIPE	A120F00031	Fuel pump output pressure measure & Injector cleaning
ELECTRIC REPAIR KIT	A120F00032	Troubleshooting electric system
RADIATOR PRESSURE GAUGE	A120F00035	Radiator pressure measure
USB LINKER	3620A-LGJ9-E00	Diagnostic tool software upgraded
POWER WIRES	32143-LGJ9-E00	Diagnostic tool power connection
INJECTOR CLEANER	32143-LEA7-9000	Injector cleaning

General Information

Name & Model No.		ADG5		
Motorcycle Name & Type		XCITING S 400		
Overall length (mm)		2190		
Overall width (mm)		800		
Overall height (mm)		1345		
Wheel base (mm)		1565		
Engine type		4 stroke SOHC		
Displacement (cc)		400		
Fuel recommended		95 # nonleaded gasoline		
Dry weight (kg)	Front wheel	82		
	Rear wheel	113		
	Total	195		
Max. weight capacity (kg)	Front wheel	127		
	Rear wheel	251		
	Total	378		
Tires	Front wheel	120/70-15		
	Rear wheel	150/70-14		
Ground clearance (mm)		120		
Performance	Braking distance (m)	12.3m/50km/hr		
	Min. turning radius	2500mm		
Engine	Starting system		Starting motor	
	Type		Gasoline, 4-stroke	
	Cylinder arrangement		SINGLE CYLINDER	
	Combustion chamber type		Semi-sphere	
	Valve arrangement		O.H.C. 4V Chain drive	
	Bore x stroke (mm)		84 x 72.1	
	Compression ratio		10.8:1	
	Compression pressure		15 (kg/cm ²), 213 (psi)	
	Max. Horsepower		35 / 7500 PS/rpm	
	Max. Torque		36 / 6000 N-m/rpm	
	Valve timing	Intake	Open	0° BTDC
			Close	35° ABDC
		Exhaust	Open	45° BBDC
			Close	0° ATDC
	Valve clearance (cold) (mm)	Intake	0.10	
		Exhaust	0.10	
	Idle speed (rpm)		1400 ± 100	
	Lubrication System	Lubrication type		Forced pressure & Wet
		Oil pump type		Inner/outer rotor type
		Oil filter type		Full-flow filtration
Oil capacity		1.5 liter		
Cooling Type		Liquid cooling		

Fuel System	Air cleaner type & No		Paper element, wet		
	Fuel capacity		12.5 liter		
	Injection	Brand		Keihin	
		Type		Throttle body	
		Venturi dia.(mm)		40.5	
Fuel pump pressure		3.0 Bar			
Electrical Equipment	Ignition System	Type		ECU	
		Spark plug	Spec	CR7E (NGK)	
			Gap	0.7~0.8mm	
	Battery Capacity		12V10AH		
Power Drive System	Clutch Type		Dry multi-clutch		
	Transmission Gear	Type		CVT	
		Operation		Automatic centrifugal type	
	Reduction Gear	Type		Two-stage reduction	
		Reduction ratio	1st	2.4~0.8	
2nd			6.967		
Moving Device	Tire type		Tubeless		
	Wheel material		Aluminum		
	Tire pressure	Front	2.0 (28.4)		
		Rear	2.25 (32)		
	Handle turning angle(L/R)	Left	40°		
Right		40°			
Brake system type		Front	Dual Disc brake		
		Rear	Single Disc brake		
Damping Device	Suspension type		Front	Telescope	
			Rear	Unit swing with 5-steps preload adjustment	
	Shock absorber stroke		Front	110 mm	
			Rear	107 mm	
Frame type		STEELL PIPE			
ENGINE					
Throttle grip free play		2 ~ 6 mm			
Spark plug		NGK: CR7E			
Spark plug gap		0.7~0.8 mm			
Valve clearance		IN: 0.10 mm	EX: 0.10 mm		
Idle speed		1400 ± 100 rpm			
Cylinder compression		15 ka/cm2	213 psi		
Ignition timing		ECU			
Coolant type		Coolant type			
Engine oil capacity					
At disassembly		1.5 Liter			
At change		1.3 Liter			
Gear oil type:		SAE 90			
Gear oil capacity					
At disassembly		0.23 Liter			
At change		0.21 Liter			

Cooling System

Radiator cap relief	0.9±0.15 kg/cm ² (12.8±2.1 psi)	
Thermostat temperature	Begins to open	71 °C
	Full-open	80 °C
	Valve lift	3.5 - 4.5 mm
Coolant capacity	Total 1700cc	Radiator: 1450 cc Reserve tank: 250 cc

COOLANT MIXTURE (WITH ANTI-RUST AND ANTI-FREEZING EFFECTS)			
Freezing Point	Mixing Rate	KYMCO SIGMA Coolant Concentrate	Distilled Water
-9°C	20%	340cc	1360cc
-15°C	30%	510cc	1190cc
-25°C	40%	680cc	1020cc
-37°C	50%	850cc	850cc
-44.5°C	55%	935cc	765cc

COOLANT GRAVITY CHART						
Temp. C°						
Coolant	0	5	10	15	20	25
5%	1.009	1.009	1.008	1.008	1.007	1.006
10%	1.018	1.107	1.017	1.016	1.015	1.014
15%	1.028	1.027	1.026	1.025	1.024	1.022
20%	1.036	1.035	1.034	1.033	1.031	1.029
25%	1.045	1.044	1.044	1.042	1.040	1.038
30%	1.053	1.051	1.051	1.049	1.047	1.045
35%	1.063	1.065	1.060	1.058	1.056	1.054
40%	1.072	1.070	1.068	1.066	1.064	1.062
45%	1.080	1.078	1.076	1.074	1.072	1.069
50%	1.086	1.084	1.082	1.080	1.077	1.074
55%	1.095	1.093	1.091	1.088	1.085	1.082
60%	1.100	1.098	1.095	1.092	1.089	1.086

Temp. C°					
Coolant	30	35	40	45	50
5%	1.005	1.003	1.001	0.009	0.99
10%	0.013	1.011	1.009	1.007	1.005
15%	1.020	1.018	1.016	1.014	1.012
20%	1.027	1.025	1.023	1.021	1.019
25%	1.036	1.034	1.031	1.028	1.025
30%	1.043	1.041	1.038	1.035	1.032
35%	1.052	1.049	1.046	1.043	1.040
40%	1.059	1.056	1.053	1.050	1.047
45%	1.056	1.063	1.062	1.057	1.054
50%	1.071	1.068	1.065	1.062	1.059
55%	1.079	1.076	1.073	1.070	1.067
60%	1.083	1.080	1.077	1.074	1.071

Fuel Injection System

ITEM	SPECIFICATIONS	
Throttle body identification number	ADG5	
Idle speed	1400 ± 100 rpm	
Throttle grip free play	2 - 6 mm (1/16 - 1/4 in)	
Fuel injector resistance (at 20°C/68°F)	9.9 – 13.5 Ω approx.	
Fuel pump resistance(at 20°C/68°F)	1.9±0.3Ω	
Fuel pump standard pressure (at 40L/Hr)	294±6 kPa (3 Bar)	
Water temperature sensor resistance	2.076 KΩ ± 10% (25°C)	
Intake pressure sensor (MAP) pressure(at 1 -4.2V)	34 – 40 kpa	
Inductive ignition coil	Primary: 3.57 -4.83Ω Secondary: 0.42~14.49KΩ	
Throttle position sensor (TPS) resistance (at 20°C/68°F)	3500Ω- 6500Ω	
Crank position sensor voltage (at 200rpm)	100Ω- 130Ω	
O2 heater sensor resistance (at 20C/68°F)	6.7 - 9.5Ω (engine warming condition)	
Tilt switch voltage	Standard	0.4 - 1.4 V
	Over 65° (fall down)	3.7 - 4.4 V

Axle/Brakes/Wheels

Item	Standard mm (in)	Service Limitmm (in)
Axle shaft run out	–	0.2 (0.008)
Brake disk thickness (front)	3.8-4.2(0.15-0.17)	3 (0.12)
Brake disk thickness (rear)	4.8-5.2(0.19-0.20)	4 (0.16)
Brake disk run out	–	0.03 (0.012)
Brake master cylinder I.D	12.7 - 12.74(0.508 -0.5096)	–
Brake master cylinder piston O.D.	12.65 - 12.68(0.506 -0.5072)	–
Front brake caliper cylinder I.D	25.4(1.0)	–
Brake lining thickness	5.4(0.21)	–

Item	Standard (mm)
Wheel rim run out service limit	max 5
Rear brake disk thickness	5.0
Rear brake disk run out	max 0.4
Rear brake caliper piston O.D.	25.33 - 25.36
Rear brake caliper cylinder I.D.	25.40 - 25.45

Torque Engine Specifications

NO	ITEM	THREAD SIZE AND TYPE	TORQUE		PR VALUES N·m	REMARKS	THREAD DWG. NO.	IND. DWG
			N·m	kgf·m				
1	BOLT, A STUD 10x180	M10x1.25	9.8~13.7	1.0~1.4	11.8	APPLY OIL	90032-LEA7-E000	—
2	NUT, STUD BOLT	M10.X1.25	33.3~37.2	3.4~3.8	35.3	APPLY OIL	94050-10060	—
3	BOLT, SET PLATE	M6X1.0	9.8~13.7	1.0~1.4	11.8		90001-GAE1-9210	—
4	THERMOSTART	M6X1.0	9.8~13.7	1.0~1.4	11.8		96001-06028-08 96001-06022-08	—
5	BOLT, SEALING	M12x1.0	9.8~19.6	1.0~2.0	14.7		12205-KHE8-3010 12205-LEA7-E000	—
6	L COVER	M6x1.0	9.8~13.7	1.0~1.4	11.8		96001-06030-08	—
7	COVER, L COVER	M6x1.0	9.8~13.7	1.0~1.4	11.8		96001-06020	—
8	CYLINDER HEAD	STUD M6x1.0	6.9~10.8	0.7~1.1	8.9	INLET PIPE AREA	92900-06040-0B	—
		STUD M8x1.25	6.9~10.8	0.7~1.1	8.9	EX PIPE AREA	90033-GY6-9000	—
9	BOLT, CAM SPROCKET	M6x1.0	6.9~10.8	1.0~1.4	8.9		90001-GFY6-9010	○
10	TAPPET ADJ NUT	M5x0.5	6.9~10.8	0.7~1.1	8.9	APPLY OIL	90206-001-0010	—
11	CAM CHAIN TENSIONER PIVOT	SPECIAL BOLT M8x1.25	7.8~11.8	0.8~1.2	9.8		14531-KHE7-9000	○
12	TENSIONER LIFTER	M6x1.0	9.8~13.7	1.0~1.4	11.8		90001-GBHB-6610	—
13	TENSIONER LIFTER	M6x1.0	3.4~4.9	0.35~0.5	4.2		90005-KAW1-9010	—
14	OIL PUMP	M6x1.0	7.8~11.8	0.8~1.2	9.8		96001-06028-08	○
15	MISSION CASE	M8x1.25	17.7~21.6	1.8~2.2	19.7		95701-08035-08 95701-08040-08	—
16	L CASE CHECK /DRAIN BOLT	M8x1.25	7.8~11.8	0.8~1.2	9.8		95701-08012-08	—
17	L CASE DRAIN BOLT	M12x1.5	19.6~29.4	2.0~3.0	24.5		9052A-LEB1-9000	—
18	DRIVE FACE	M18x1.0	77.5~85.3	7.9~8.7	81.4	APPLY OIL	94050-LKF5-E000	—
19	CLUTCH OUTER	M14x1.0	55.9~61.8	5.7~6.3	58.9	APPLY OIL	90201-LKF5-E000	—
20	DRIVE PLATE COMP	M36x1.5	84.4~93.2	8.6~9.5	88.8		90202-LDB5-E000	○
21	ONEWAY CLUTCH	BOLT SOCKET M6x1.0	7.8~11.8	0.8~1.2	9.8	APPLY THREAD LOCK	96600-06015-10	—
22	ACG FLYWHEEL	N.F. M14x1.25	53.9~63.7	5.5~6.5	58.8		90201-KR8-7520-M1	—
23	SPARK PLUG	M10x1.0	9.8~13.7	1.0~1.4	11.8		98059-57916-00	—
24	ACG STATOR	M5x0.8	7.8~9.8	0.8~1.0	8.8		92000-LEA6-9000	—
25	OTHERS	SH BOLT	7.8~11.8	0.8~1.2	9.8		—	—
26	CONN. ROD	SH BOLT	40.2~44.1	4.1~4.5	42.2	APPLY OIL 5W-50 2.5~4.3	13212-LKF5-E000	○
27	SW ASSY, OIL PRESSURE	PT 1/8	20.3~29.3	2.1~3.0	24.8	APPLY SEAL	35500-KED9-9000	○

Torque Frame Specifications

No.	ITEM	THREAD SIZE AND TYPE	TORQUE		Kgf-m	REMARK	THREAD DWG NO.	Imp t
			Kgf-m	N-m				
1	STEERING							
	HANDLE NUT	M8x1.25	3.0~4.0	30~40	3.5	U NUT	90304-LEA1-9000	A
	STEM NUT(TOP BRID.)	M22x1.5	6.0~6.5	60~65	6.2	—	90304-KKE5-E000	A
	TOP BRIDGE BOLT	M8x1.25	2.0~2.6	20~26	2.3	—	96600-08025-06	A
	BOT BRIDGE BOLT	M8x1.25	2.4~3.0	24~30	2.7	FLANGE BOLT	95801-08040-08	A
	STEM LOCK	BC1	5.0~6.0	50~60	5.5	—	50306-1F96-0010	A
	RACE NUT(HEAD)	BC1	0.8~1.2	8~12	1.0	—	53220-LBA2-E000	B
2	WHEEL							
	FR. AXLE BOLT	M14x1.5	1.5~2.5	15~25	2.0	—	50604-KED9-9500	A
	RR. AXLE NUT	M16x1.5	13~15	130~150	14	U NUT	90305-KKAK-9000	A
3	SUSPENSION							
	FR FORK BOLT	M8x1.25	2.0~2.6	20~26	2.3	—	96600-08035-06	A
	RR. CUSH. UP	M10x1.25	3.5~4.5	35~45	4.0	—	90304-GLW0-9020-MI	A
	RR. CUSH. LWR	M10x1.25	3.5~4.5	35~45	4.0	—	95801-10040-06	A
4	BRAKE							
	FR CALIPER	M10x1.25	3.0~4.0	30~40	3.5	—	90122-LKF5-E000	A
	RR CALIPER	M10x1.25	3.0~4.0	30~40	3.5	—	90122-LEA7-E000	A
	BRK OIL BOLT	M10x1.25	3.0~4.0	30~40	3.5	—	90145-MS9-6120-MI	A
	M/C HOLDER	M6x1.0	1.0~1.4	10~14	1.2	—	96001-06028-06	C
	M/C CAP SCREW	M4x0.7	0.12~0.2	1.2~2.0	0.16	—	93600-04012-1G	B
	C/P BLEEDER	M8x1.25	0.4~0.7	4.0~7.0	0.55	—	4335A-LBA2-E100	B
	DISK BOLT	M8x1.25	3.2~3.8	32~38	3.5	—	90105-KCR3-0010	A
5	ENG HANGER							
	FRAME SIDE	M14x1.5	6.0~7.0	60~70	6.5	U NUT	90106-LEA7-E000	A
	ENG SIDE	M14x1.5	6.0~7.0	60~70	6.5	U NUT	90305-LBD4-9000	A
6	MUFFLER							
	EXH. PIPE	M8x1.25	1.8~2.2	18~22	2.0	—	90033-GFY6-9000	B
	MUFF. BRKT/RR FORK	M10x1.25	3.5~4.5	35~45	4.0	FLANGE BOLT	95801-10060-06	A
7	RR FORK/ENG CASE	M10x1.25	3.0~4.0	30~40	3.5	—	95801-10060-06	A
	RR FORK/RR FORK A	M8x1.25	2.4~3.0	24~30	2.7	—	90131-KEBE-9000	B
8	SPDMT SENSOR CABLE	M6x1.0	1.0~1.4	10~14	1.2	—	96001-06012-06	C
	IGN COIL	M6x1.0	1.0~1.4	10~14	1.2	—	94050-06080	B
	O2 SENSOR	M12x1.25	2.0~3.0	20~30	2.5	—	—	B
	MAIN STAND	M10x1.25	3.0~4.0	30~40	3.5	U NUT	90304-LEA1-9000	A
	RR CARRIER	M8x1.25	2.0~2.8	20~28	2.4	—	90106-KKC4-9000	C

General Torque Specifications

Item	Torque	
	kgf-m	lb-ft
5 mmbolt, nut	0.45-0.6	3.25 - 4.34
6 mmbolt, nut	0.8-1.2	5.79 - 8.68
8 mmbolt, nut	1.8-2.5	13.02 - 18.08
10 mmbolt, nut	3.0-4.0	21.70 - 28.93
12 mmbolt, nut	5.0-6.0	36.17 - 43.40
5 mm screw	0.45-0.6	3.25 - 4.34
6 mmscrew, SH bolt	0.7-1.1	5.06 - 7.96
6 mm flange bolt, nut	1.0-1.4	7.23 - 10.13
8 mm flange bolt, nut	2.4-3.0	17.36 - 21.70
10 mm flange bolt, nut	3.0-4.5	21.70 - 32.55

Troubleshooting

Vehicle can not be started

Preliminary 6 Step Inspection

1. Is the battery fully charged (12 V or higher). See the Battery topic for more information.
2. Key-On and listen for any action with Fuel Pump / Fuel Pump Relay (It will turn off automatically in 5-10 seconds)
3. Key-On to check for any failure lamp light up on dashboard. See theSelf-Diagnosis topic for more information.
4. Is the Idle screw of Throttle Valve being changed or loose?
5. Has the vehicle under regular service? Is the gas station a good one?
6. Is the spark plug the correct model of specified by the vehicle builder? See the Spark Plug topic for more information.

General Troubleshooting

ENGINE WILL NOT START OR IS HARD TO START

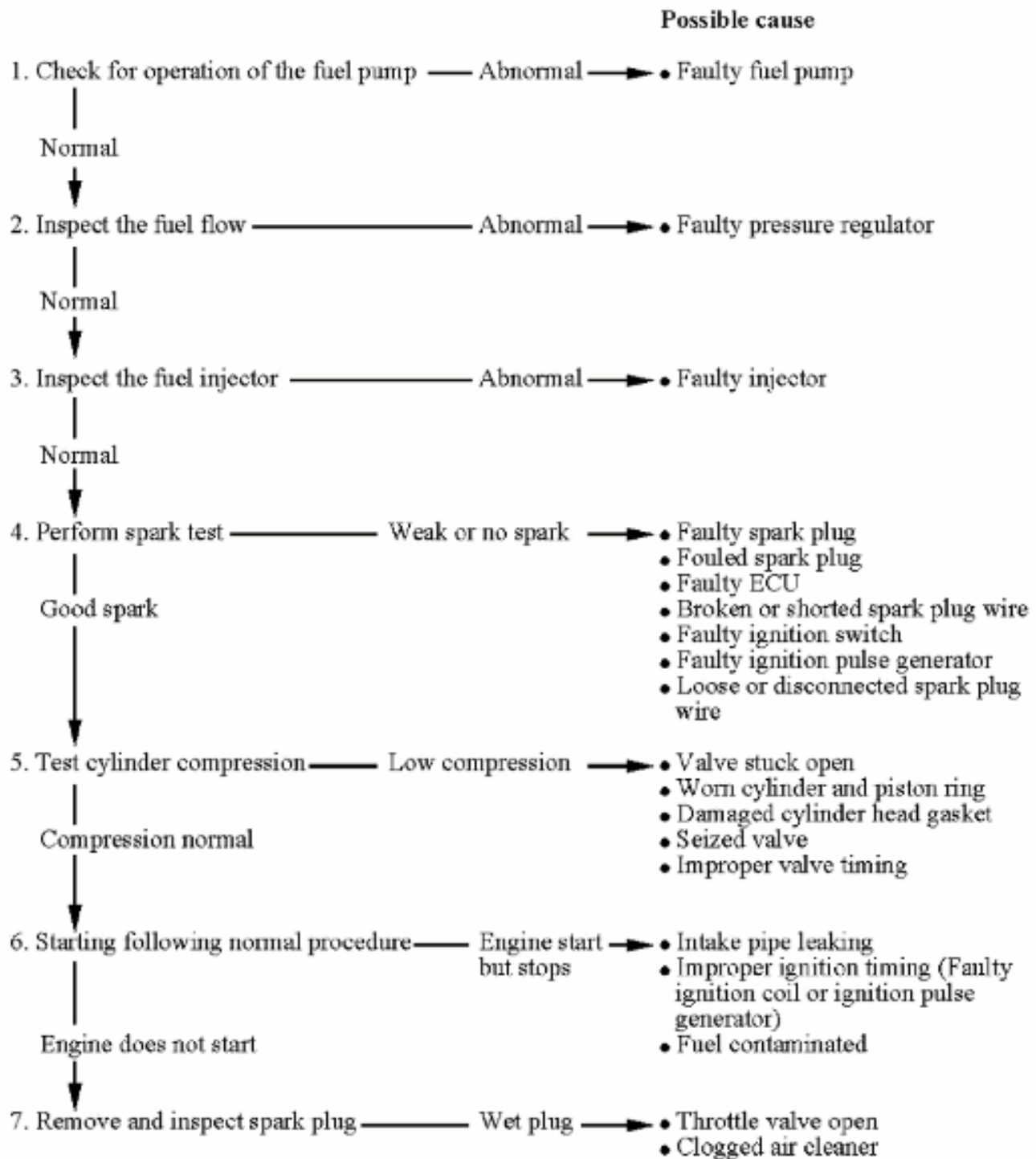

ENGINE LACKS POWER

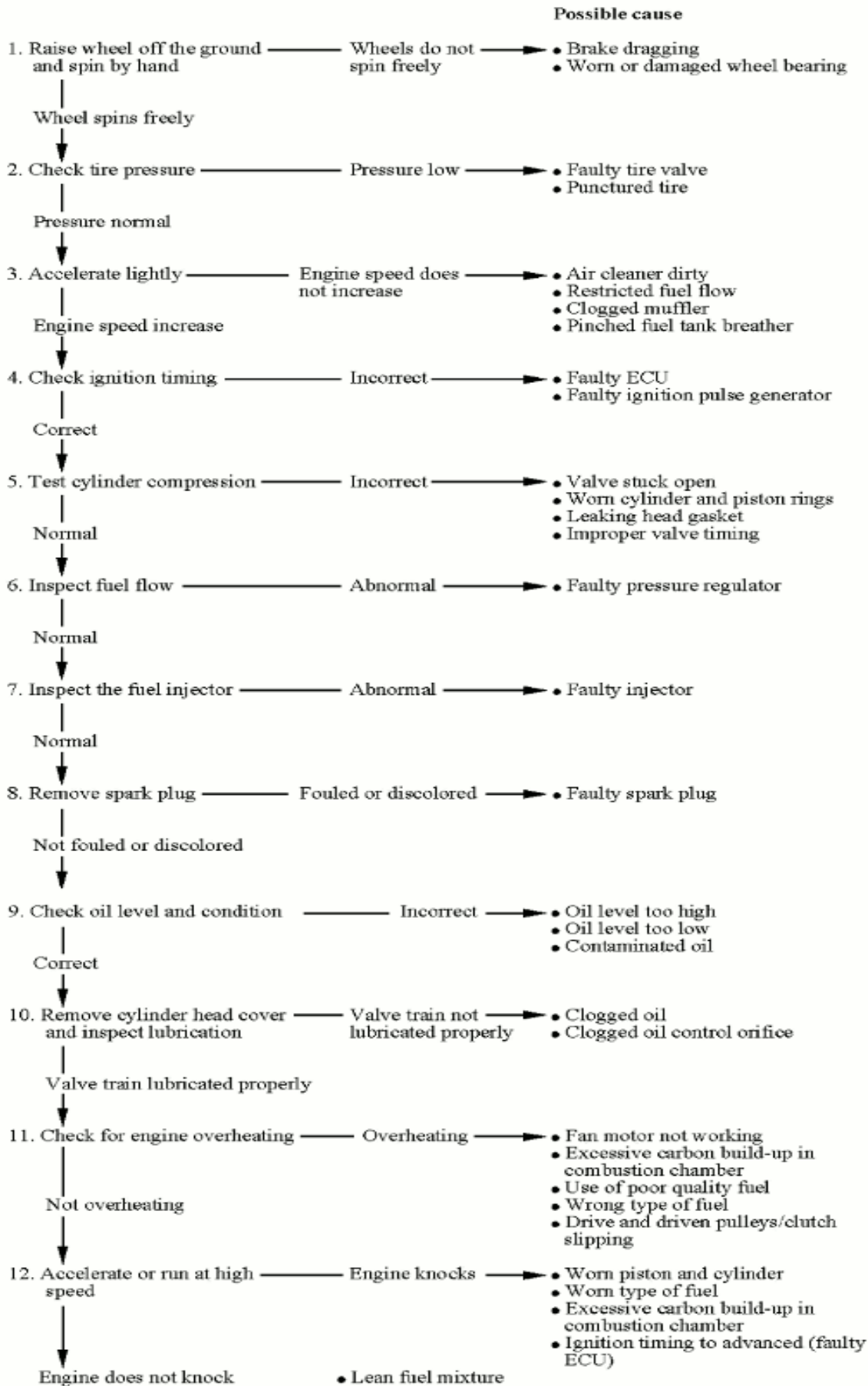

POOR PERFORMANCE AT LOW AND IDLE SPEED

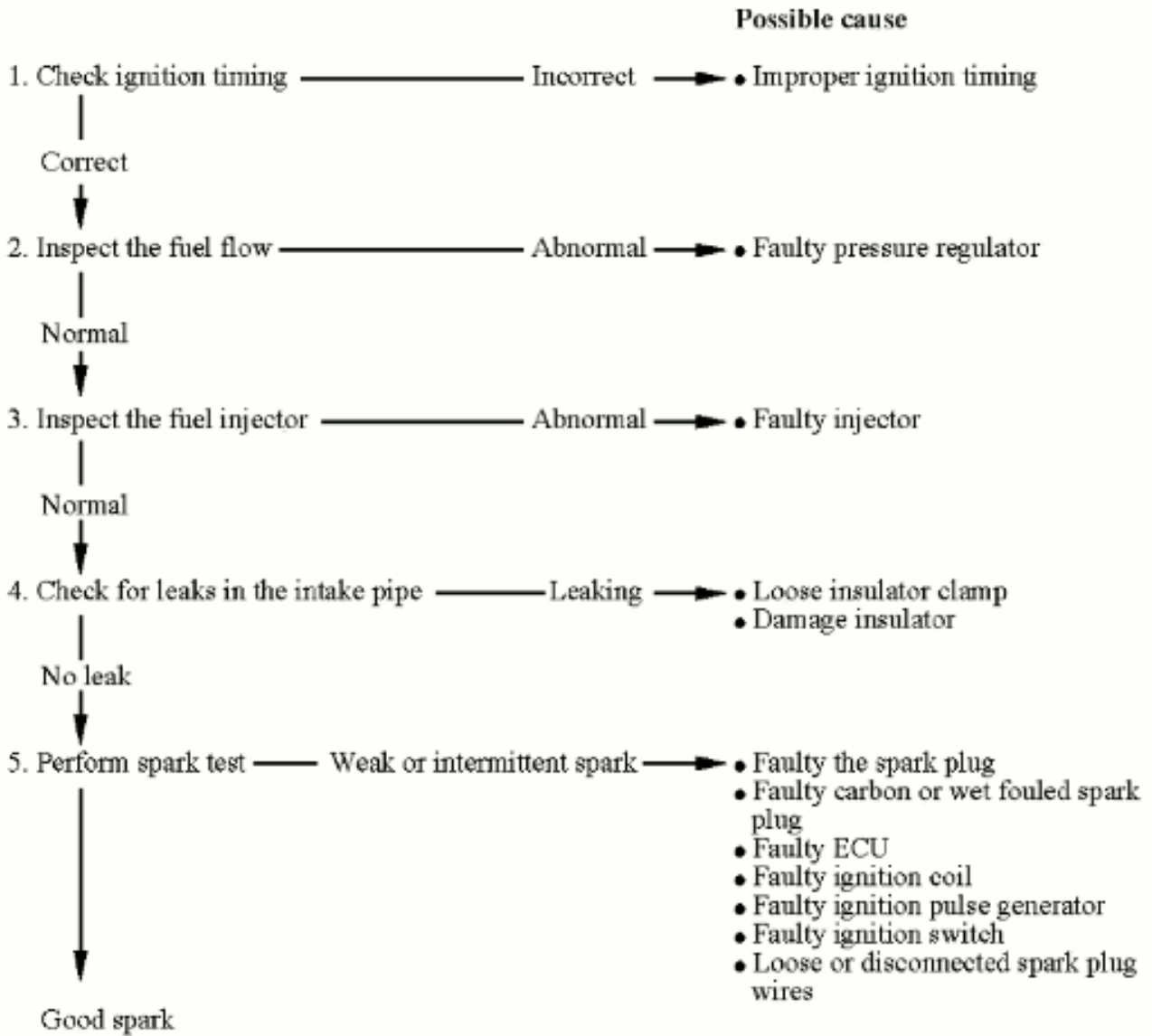

POOR PERFORMANCE AT HIGH SPEED

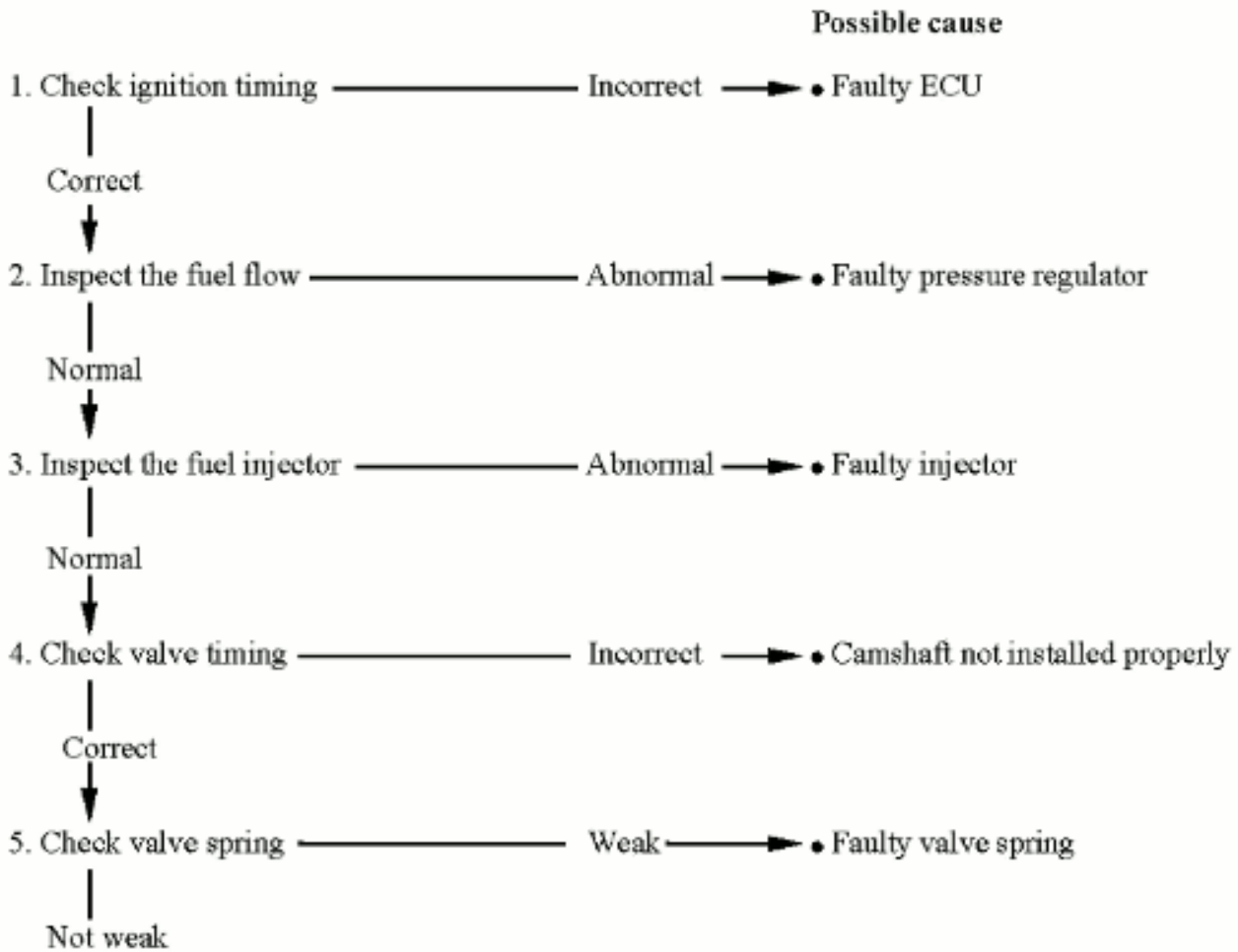

POOR HANDLING

	Possible cause
1. If steering is heavy	<ul style="list-style-type: none"> • Steering stem adjusting nut too tight • Damaged steering head bearings
2. If either wheel is wobbling	<ul style="list-style-type: none"> • Excessive wheel bearing play • Bent rim • Improper installed wheel hub • Swing arm pivot bearing excessively worn • Bent frame
3. If the motorcycle pulled to one side	<ul style="list-style-type: none"> • Faulty the shock absorber • Front and rear wheel not aligned • Bent fork • Bent swing arm • Bent axle

VIN and Engine Number Location

Owner Information

ID Number Record Field

Please note down the Engine Number and Vehicle Frame Number in the relevant fields below, to facilitate ordering spare parts from a KYMCO dealer, or for reference in the event of a lost of vehicle.

ID Number Record Field:

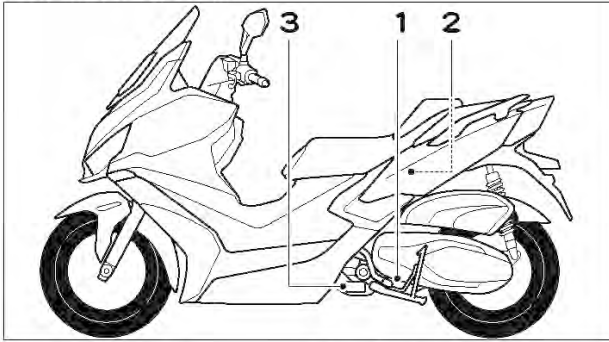

1: Engine Number engrave
3: Aluminum Nameplate

2: Frame Number engrave

Engine Number:

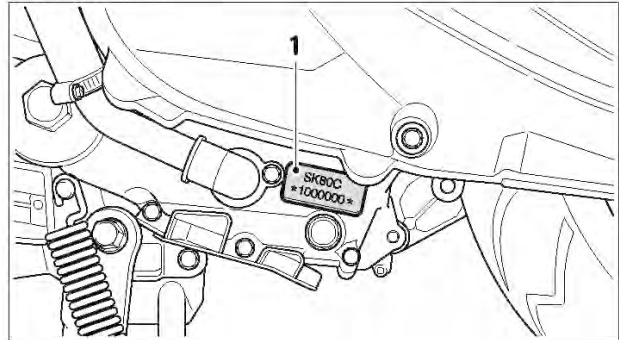

1: Engine Number engrave

The Engine Number is engraved on the crank case as shown in the figure.

Frame Number:

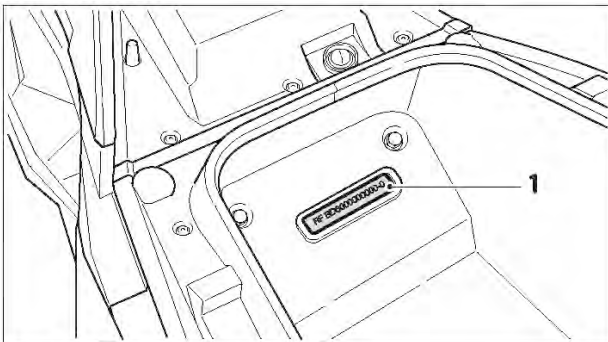

1: Frame Number engrave

The Frame Number is engraved on the chassis as shown in the figure. The Frame Number can be seen from lower-right upwards.

Aluminum Nameplate

The Aluminum Nameplate can be seen behind the Rear Cushion.

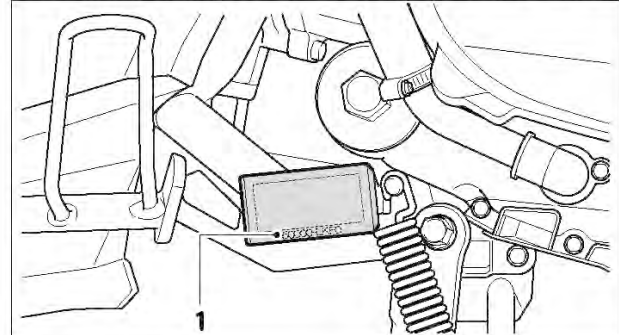

1: Aluminum Nameplate

2.Periodic Maintenance

This chapter covers the periodic maintenance for the KYMCO XCITING S 400.

Maintenance Schedule	2-2
Air Filter Servicing	2-4
Brake Fluid	2-5
Brake Inspection	2-9
Coolant	2-15
Engine Oil	2-19
General Lubrication	2-23
Side Stand	2-24
Spark Plug	2-25
Engine Compression Test	2-27
Steering Inspection	2-28
Throttle Free Play	2-29
Parking Brake	2-30
Tires	2-31
Valve Clearance Adjustment	2-32

WARNING:

- Before running the engine, make sure that the working area is well ventilated. Never run the engine in a closed area. The exhaust contains poisonous carbon monoxide gas, which may cause death to people.
- Gasoline is extremely flammable and is explosive under some conditions. The working area must be well ventilated and do not smoke or allow flames or sparks near the working area or fuel storage area.

Maintenance Schedule

Perform the pre-ride inspection at each scheduled maintenance period. This interval should be judged by odometer reading or months, whichever comes first.

Maintenance schedule

I: Inspection; clean, lubricate, replenish, remedy or replace as required. A: Adjustment. C: Cleaning. R: Replace. T: Tightening. M: Maintenance. D: Diagnosis

The maintenance schedule specifies the maintenance required to keep your XCITING S 400 scooter in peak operating condition. Maintenance work should be performed in accordance with KYMCO standards and specifications by properly trained and equipped technicians. Your KYMCO dealer meets all of these requirements.

* Should be serviced by your KYMCO dealer, unless you have the proper tools, service data and are technically qualified.

** In the interest of safety, we recommend these items be serviced only by your KYMCO dealer. KYMCO recommends that your KYMCO dealer road test your scooter after each periodic maintenance service is completed.

Maintenance schedule notes:

1. At higher odometer readings, repeat at the frequency interval established here.
2. Service more frequently if the scooter is ridden in unusually wet or dusty areas.
3. Service more frequently when riding in rain or at full throttle.
4. Inspect every 12,000 mi (20,000 km) after replacement.
5. Replace every 1 year, or every 6,000 mi (10,000 km), whichever comes first. Replacement requires mechanical skill.
6. Replace every 2 years, or at the indicated odometer interval, whichever comes first. Replacement requires mechanical skill.
7. Replace every 2 years. Replacement requires mechanical skill.

FREQUENCY ITEM		WHICEVER COMES FIRST ↓	ODOMETER READING									
			→	1	5	10	15	20	25	30	35	40
			X 1000km	0.6	3	6	9	12	15	18	22	24
Note		Month	1	6	12	18	24	30	36	42	46	
*	AIR CLEANER	Note2		R	R	R	R	R	R	R	R	
*	V-BELT CASE AIR FILTER ELEMENT			C	C	C	C	C	C	C	C	
	SPARK PLUGS			I	R	I	R	I	R	I	R	
*	THROTTLE OPERATION			I	I	I	I	I	I	I	I	
*	VALVE CLEARANCE			I	A	I	A	I	A	I	A	
*	FUEL LINE				I		I		I		I	
	CRANKCASE BREATHER	Note3		C	C	C	C	C	C	C	C	
*	ENGINE OIL			R	R	R	R	R	R	R	R	
*	ENGINE OIL SCREEN			C	R	C	R	C	R	C	R	
*	ENGINE OIL FILTER			R	R	R	R	R	R	R	R	
*	ENGINE IDLE SPEED				D		D		D		D	
*	TRANSMISSION FLUID	Note5		R		R		R		R		
*	DRIVE BELT	Note4		I	I	I	R	I	I	I	R	

FREQUENCY ITEM		WHICEVER COMES FIRST ↓	ODOMETER READING									
			→	1	5	10	15	20	25	30	35	40
			X 1000km	0.6	3	6	9	12	15	18	22	24
Note		Month	1	6	12	18	24	30	36	42	46	
**	CLUTCH SHOE WEAR				I		I		I		I	
	BRAKE FLUID	Note7		I	R	I	R	I	R	I	R	
	BRAKE PAD WEAR			I	I	I	I	I	I	I	I	
	BRAKE SYSTEM			I	I	I	I	I	I	I	I	
*	BRAKE LIGHT SWITCH			I	I	I	I	I	I	I	I	
**	STEERING BEARINGS			I	I	I	I	I	I	I	I	
*	HEADLIGHT AIM			I	I	I	I	I	I	I	I	
*	NUTS , BOLTS , FASTENERS			I	I	I	I	I	I	I	I	
**	WHEELS / TIRES			I	I	I	I	I	I	I	I	
**	COOLANT	Note6		I	R	I	R	I	R	I	R	
**	INJECTOR			D	C	D	C	D	C	D	C	

Air Filter Servicing

Replace Air Filter as specified in Regular Maintenance Schedule. Check and replace Air Filter Cartridge more frequently if vehicle is often used in dusty environments or damp areas.

Replace Air Filter Cartridge

1. Remove outer casing of vehicle.
2. Remove Air Filter Cover.
3. Loosen Air Filter Cover Fixing Screw and take out the element.

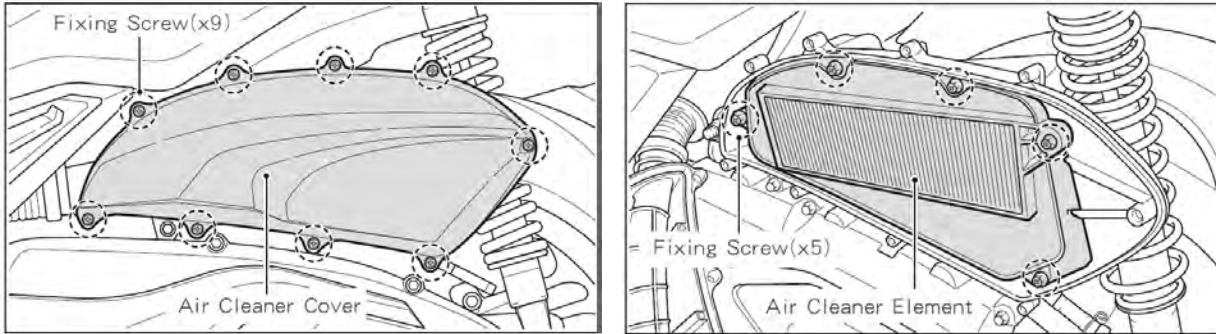

Precautions on replacing Filter Element:

1. Make sure the Air Filter element is positioned correctly in the casing.
2. Do not start engine when Air Filter is not installed, or dirty air may enter the engine and cause abnormal wear.
3. Do not wet the Air Filter element when cleaning the vehicle, or engine start may become difficult.
4. Install Air Filter Cover and tighten Fixing Screw.
5. Re-install outer casing of vehicle.

Brake Fluid

The KYMCO XCITING S 400 uses DOT 4 brake fluid that should be inspected after 3,000 mi (5,000 km) of use. It should be flushed and bled every 12 months, 6,000 mi (10,000 km), whenever the brakes feel spongy, or if the brake system has been taken apart and rebuilt. Always use fresh brake fluid from a tightly sealed container.

SAFETY FIRST: Protective gloves and eyewear are recommended at this point.

Checking Front Brake Fluid

1. Straighten the Handlebar, check brake fluid in the Right Reservoir. Keep the level between the Upper Mark and Lower Mark.
2. If level lowers near the Lower Mark, check the brake lining for a worn condition.
3. If the brake lining is not worn exceeding a specified limit, most likely there is a leakage of brake fluid; go to a dealer for repair.

Viewing Window of Front Brake Fluid

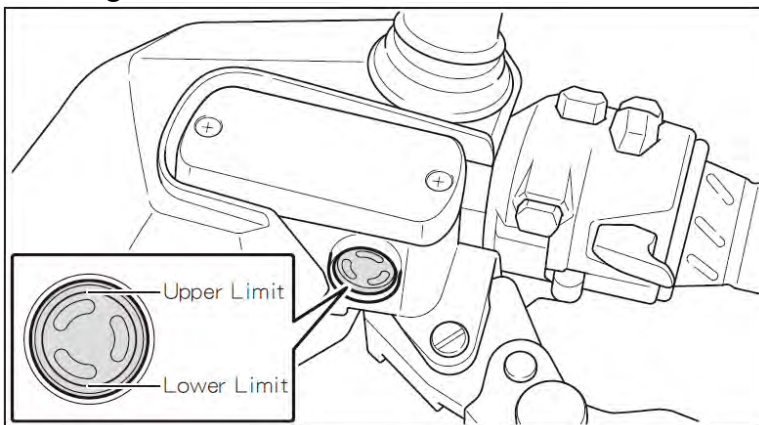

Warning: Brake fluid is very caustic and can damage paint, chrome and plastic. Wipe up any spills immediately.

Replenishing Brake Fluid

1. Straighten the Handlebar, remove 2 fixing screws of Reservoir and remove Reservoir Cover.
2. Replenish Reservoir with recommended DOT-4 Brake Fluid to the Upper Scale. Replace Reservoir Cover and tighten 2 fixing screws.
3. Replace Brake Fluid every 10000km or 1 year.

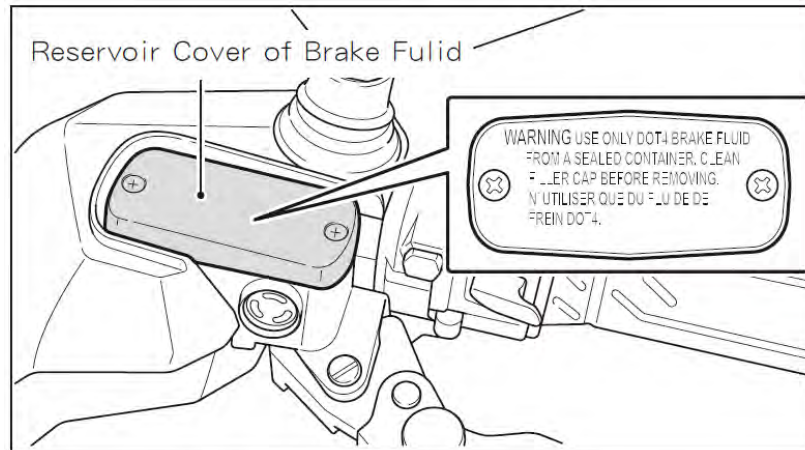

WARNING

- ◆ Mixed use of Brake Fluids of different brand and different specifications may result in braking fault and danger.
- ◆ When replenishing braking fluid, cover coated parts with a cloth to prevent damaging them.

Draining

The brake bleeding process is the same for the front and rear brakes. Remove the two master cylinder cover screws with a #2 Phillips head screwdriver. Remove the master cylinder cover, plastic piece and rubber accordion diaphragm. Pour out any remaining brake fluid.

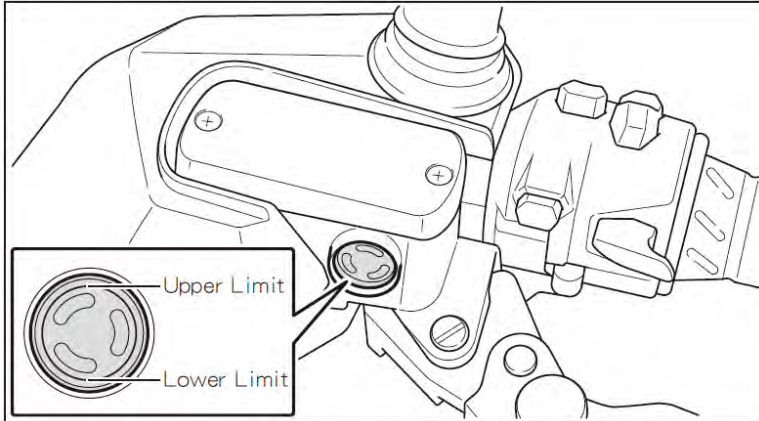

Clean and inspect the rubber diaphragm for tears or other damage. Replace as necessary.



Pull off the rubber cap over the bleeder valve and crack open the bleeder valve on the brake caliper using an 8 mm wrench. This valve is usually very tight so use a box end wrench or a 6 point socket and ratchet to prevent rounding off the head. Snug the bleeder valve back down.

Open the valve and remove the old brake fluid with a Mighty -Vac or a similar device.

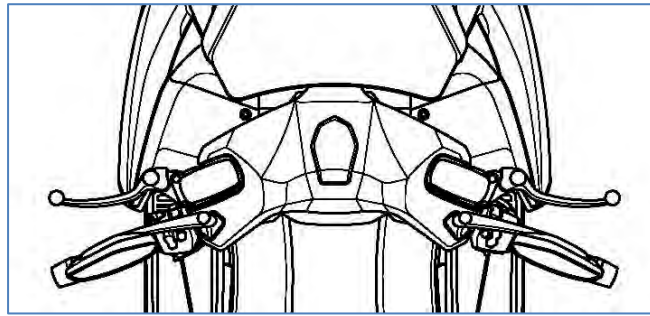

Pump the brake lever several times and hold the lever in. While holding the lever in, crack open the bleeder valve. The front brake lever will travel all the way to the grip and brake fluid and/or air will come out of the bleeder valve into the 6 mm hose. Tighten the bleeder valve before releasing the front brake lever. Pump the lever several times again and repeat the process.

Be certain to check the master cylinder reservoir occasionally to make sure the reservoir doesn't run dry. Add more brake fluid as necessary. Continue this process until clean brake fluid comes out of the bleeder valve and there are no air bubbles. The brake lever should feel firm.

Tighten the bleeder valve to specification and push its rubber cover over the nipple.

Make sure the reservoir has the proper amount of fluid.

Place the rubber diaphragm, plastic piece and cover over the reservoir.

Thread in the reservoir cover screws and tighten them securely with a #2 Phillips screwdriver.

Check the function of the brakes before operating the machine.

Brake Inspection

Brake Lever Adjuster

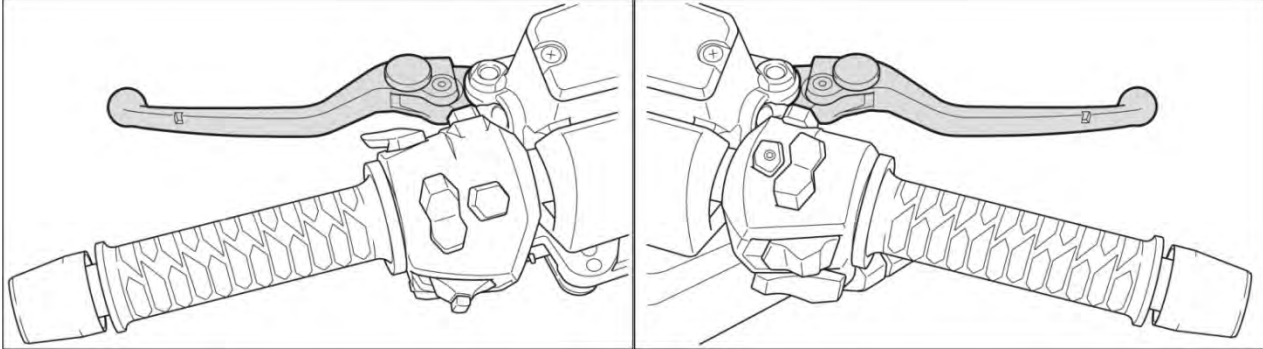

There is adjuster on each brake lever. Each adjuster has four positions so that the released lever position can be adjusted to suit the rider's hands. To adjust the distance of the lever from the handlebar grip, push the lever forward and turn the adjuster knob to align the number with the arrow mark on the lever holder.

Check and Adjust Brakes

1. Adjust brake lever clearance using adjustment knob (totally 4 adjustment positions).
2. Push the brake lever forward when adjusting the knob (default setting is 2).
3. After adjustment, pull the Brake Lever (1) with hand until reaching a position where fingers feel comfortable; check if the clearance at the front end of Brake Lever is within the specified dimension.

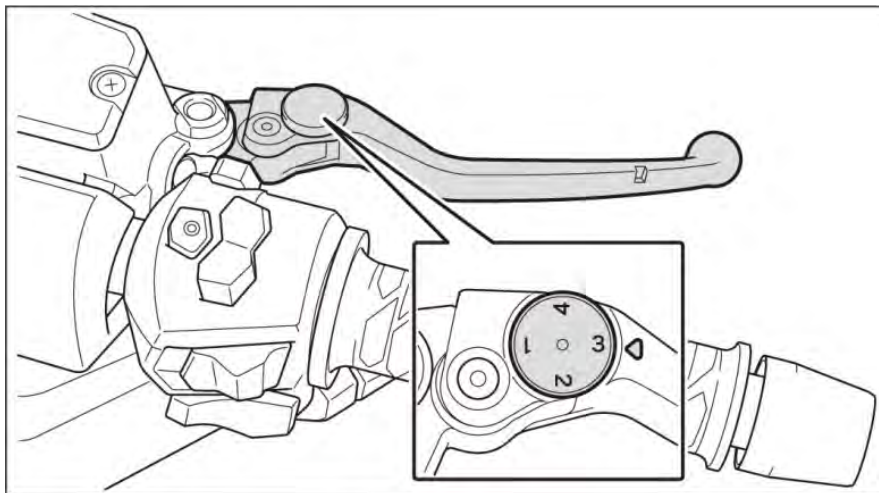

Brake Pad

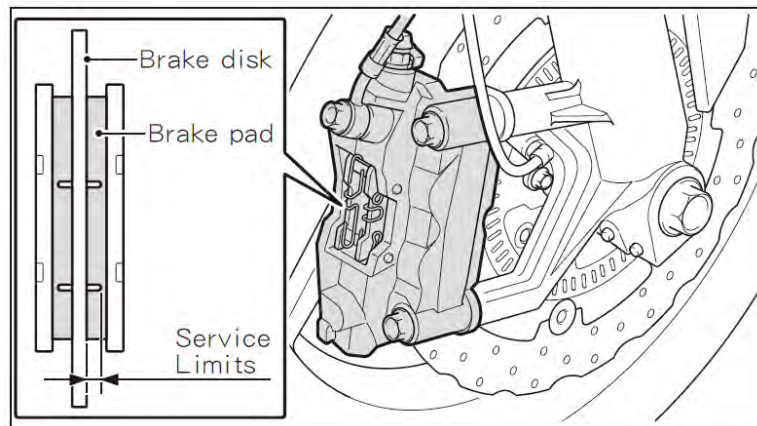

- ◆ Is braking effective?
- ◆ Verify braking effect of front and rear brakes in low speed.

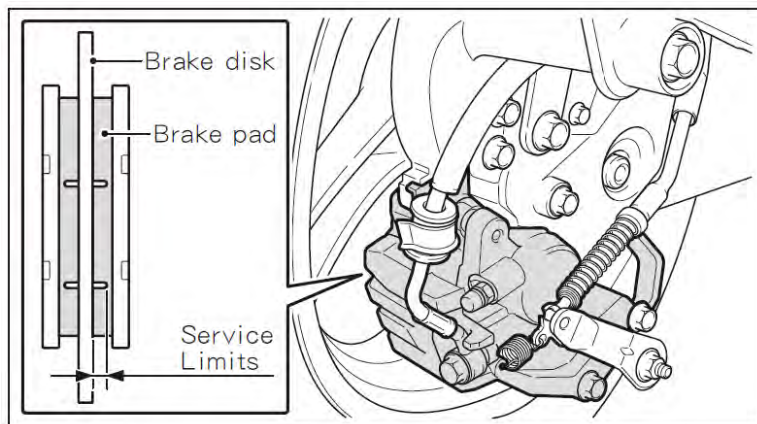

Caliper

SAFETY FIRST: Protective gloves and eyewear are recommended at this point.

Removal

Brake Pads



Push the caliper body inward to push in the pistons.
This will allow room to change the brake pads.



Remove the two caliper mounting bolts with a 12 mm socket.
Discard the brake caliper mounting bolts.



Remove the front brake caliper.
The brake calipers are each mounted to the front fork with two bolts.



Remove the brake pads with a 6mm Allen.



Free the brake pads from the pad retainer.
Remove the brake pads.



Remove the brake pad Clips with a splcier.



Replace the pads if the brake wear exceeds the wear indicator lines or if the wear is uneven. Always replace brake pads as a set.

Caliper



Place a suitable container under the banjo bolt to catch any remaining brake fluid. Remove the banjo bolt that holds the brake hose to the caliper using a 12 mm socket. Discard the two sealing washers.



The brake calipers are each mounted to the front fork with two bolts.



Remove the two caliper mounting bolts with a 12 mm socket. Discard the brake caliper mounting bolts.



Remove the brake caliper from the fork leg.
When installation:

Apply a light coat of waterproof grease to the brake pad pin. Push the pads against the pad spring and insert the brake pad pin.

It may be necessary to spread the pads and force the pistons back into the caliper in order to allow room for the brake disc to fit between the new pads.

Install the front caliper. Guide the brake disc between the pads. Line up the caliper bracket mounts with the fork.

Install the two caliper bracket mounting bolts. Tighten the mounting bolts to specification.

Coolant

For the sake of safety, check level of cooling water before riding the vehicle. Replace the cooling liquid as specified in Regular Maintenance Schedule.

Check Level of Cooling Water

1. Park the vehicle on level ground and brace it up with Main Stand.
2. Figure to be inserted

NOTICE

- ◆ Temperature in the engine may cause false reading of Cooling Water level. Check water level after the engine cools down.
 - ◆ Inclined vehicle may cause false reading of Cooling Water level.
3. Check level of Cooling Water via viewing window on the water preserving tank. Make sure the level is between “F” and “L” marks.

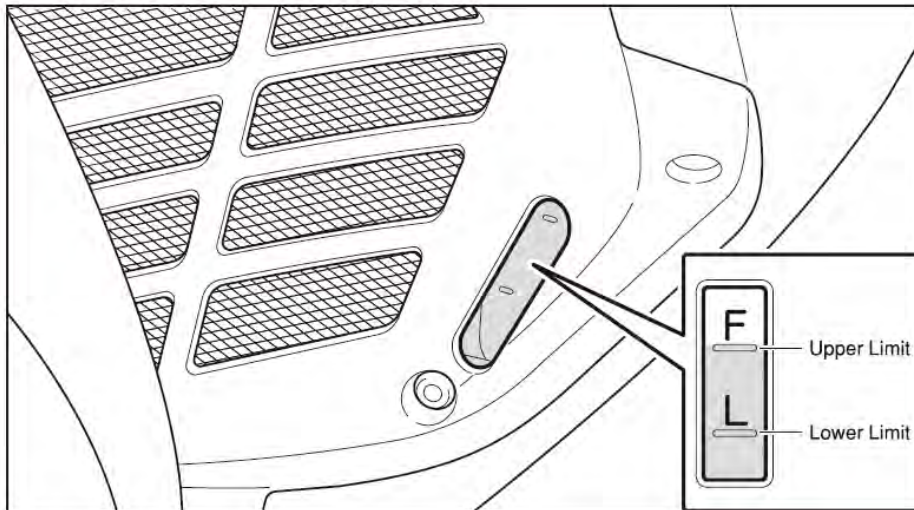

NOTICE

- ◆ Before riding the vehicle, check the water tank and piping or any leakage.
- ◆ Check the ground where the vehicle is parked for any leakage mark.
- ◆ Before riding the vehicle, check the fin and front protection screen of water tank for any foreign object. Foreign objects may reduce the cooling function or even cause vehicle or engine damage in worse conditions.

Replenish Cooling Water (Fill the Reserve Water Tank)

1. Stand the vehicle upright on level ground.
2. Open Reserve Water Tank (remove screw 1 and cover 2), replenish water to Upper Limit.

If level of cooling water gets excessively low, something must be wrong. Go to a KYMCO Dealer for check and repair.

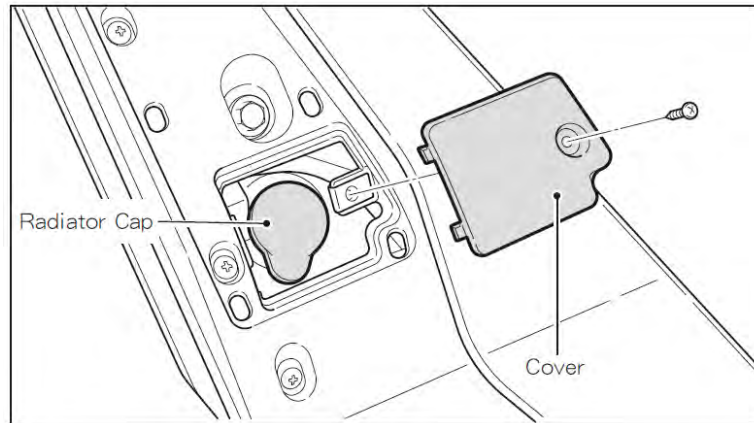

NOTICE

- ◆ Water temperature is very high after riding, do not open the cap of water tank.
- ◆ Use soft water for mixing cooling liquid.
- ◆ Using poor quality cooling water may shorten the service life of water tank. Please be careful.
- ◆ Replace cooling water in the tank every 10000km.
- ◆ Add proper amount of water tank additives to ensure performance of the cooling system.

In case of fault of vehicle:

Go to a KYMCO dealer for check and repair if any fault occurs when riding the vehicle. Use only original parts for replacement.

Check following items if engine does not start or engine stops when riding the vehicle:

- ◆ Whether gasoline is sufficient.
- ◆ Whether Dashboard Fuel Indicator approaches E. Replenish with 95 unleaded gasoline or better.
- ◆ Whether proper method is used for starting the engine.
- ◆ Others, whether any part is faulty.

Filling

When the coolant has finished draining return the drain bolt to the water pump with a new sealing washer. Tighten the drain bolt securely with an socket.

Fill the cooling system with a mix of distilled water and KYMCO SIGMA Coolant Concentrate. Continue filling until the coolant reaches the bottom of the filler neck as shown.



- Use coolant of specified mixing rate. (The mixing rate of KYMCO coolant/distilled water is 50%.)
- Do not mix coolant concentrate of different brands.
- Do not drink the coolant, which is poisonous.
- The freezing point of coolant mixture shall be 5 °C lower than the freezing point of the riding area.

Add coolant to the reserve tank until it reaches the upper level mark.

Gently rock the vehicle side-to-side to release any air bubbles trapped in the cooling system.

Place the vehicle on its center stand and start the engine. Let it run for several minutes. This will purge any air out of the cooling system. Check for coolant leaks



When the air bubbles stop coming up turn off the engine and recheck the coolant level, add coolant if necessary. Check the reserve tank and add coolant if needed. Wet the seal of the radiator cap and install.

Engine Oil

SAFETY FIRST: Protective gloves and eyewear are recommended at this point.

Caution: Hot engine oil can burn. Avoid letting used motor oil contact exposed skin.

TROUBLESHOOTING

Oil level too low

1. Natural oil consumption
2. Oil leaks
3. Worn or poorly installed piston rings
4. Worn valve guide or seal

Poor lubrication pressure

1. Oil level too low
2. Clogged filter or oil passages
3. No use the specified oil

Oil Level Inspection

Check the engine oil level each day before operating the scooter.

Place the motorcycle upright on level ground for engine oil level check. Run the engine for 2 ~ 3 minutes and check the oil level after the engine is stopped for 2 ~ 3 minutes.

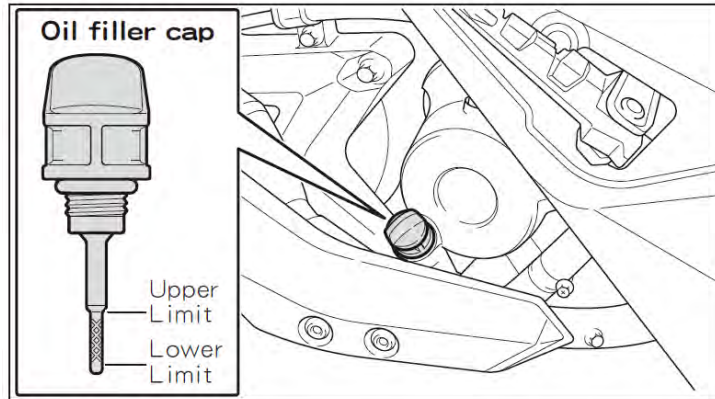

The oil filler cap/dipstick is located on the left side of the engine.

Remove the oil filler cap/dipstick and wipe off the oil. Inspect the O-ring and replace it as needed. Insert the dipstick in without threading it in. Remove the dipstick and check the oil level.

The level must be maintained between the upper and lower level marks on the oil filler cap/dipstick.

If the oil level is at or below the lower mark add more of the same type and brand of oil to the engine through the oil filler hole. If the oil level is too high remove the drain plug and the excess oil.

Oil Change Period

First oil change when running 1000km; afterwards every 5000km.

In order to maintain optimal engine performance, check oil level every 1000km. Replenish to standard level in case of shortage.

Oil Capacity:

Dismantle: 1.5L (full capacity)

Change oil: 1.3L

NOTICE

If vehicle is used rarely and 5000km is not reached after using for 6 months, it is suggested that oil shall still be changed since it may deteriorate along with time and cause damage to the engine.

Applicable Temperature of Engine Oil

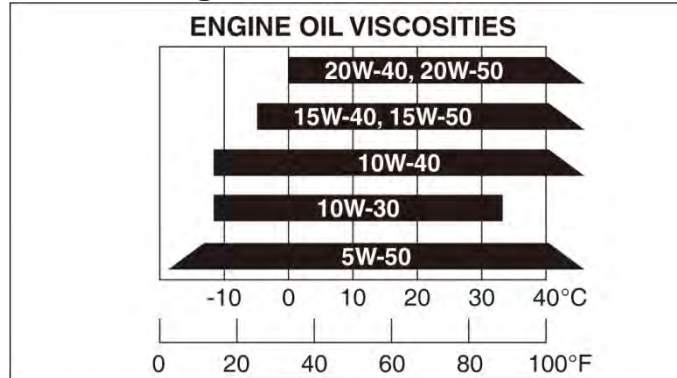

NOTICE

◆ To avoid using poor quality oil, please go to a KYMCO dealer for oil change.

Oil Change Method

1. Remove Oil Scale. Remove Drain Cock. Drain all the oil. Warming up the engine before changing oil facilitates oil draining.

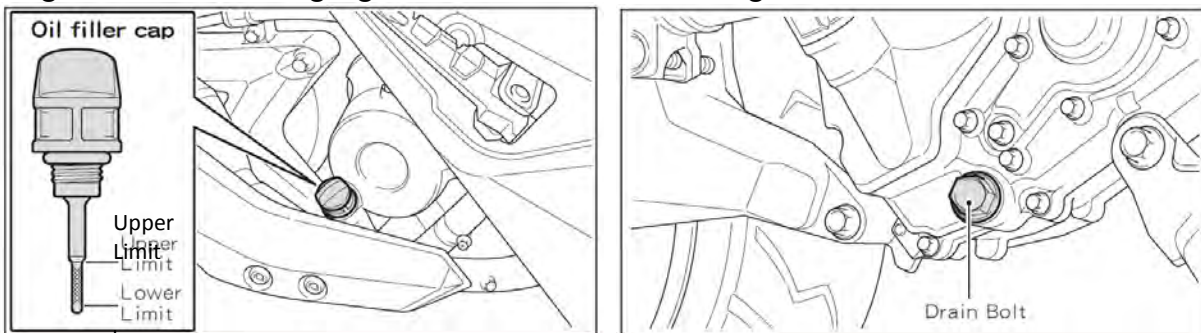

3. Fill in new oil. Filling capacity is 1.5L.

Oil Capacity:

Dismantle: 1.5L (full capacity)

Change oil: 1.3L

⚠ NOTICE

- ◆ **It is recommended to use KYMCO original 4-stroke engine oil.**
- ◆ **The following conditions may expedite oil deterioration, an early oil change is advised.**
 - Riding on pebbled roads often.**
 - Riding short distances often.**
 - Idling often.**
 - Riding in the cold area.**
- ◆ **When replenishing oil, make sure the oil level is not exceeding the Upper Limit mark.**
- ◆ **Do not mix-use oils of different brand, class or low quality ones; they may cause engine faults.**
- ◆ **Change oil while the engine is still hot; be careful not to burn your skin.**

Precautions on Oil Change

- ◆ **Excessive and insufficient oil amount can both affect engine performance.**
 - Excessive Oil**—Increased friction resistance of moving parts in the engine, which lowers output power and increases engine temperature, leading to early deterioration of engine oil.
 - Insufficient Oil**—Reduced oil supply to moving parts in the engine, therefore results in worn parts, parts ablation, etc.
- ◆ **Do not mix-use oils of different brand, class or low quality ones; they may cause engine faults.**
- ◆ **Kymco Emissary Engine Oil contains additives (e.g., spirits, etc.) during the manufacturing process.**
- ◆ **Arbitrarily mixing additives bought from the market may deteriorate the oil, affect lubricating properties and shorten the service life of engine.**

General Lubrication

SAFETY FIRST: Protective gloves and eyewear are recommended at this point.

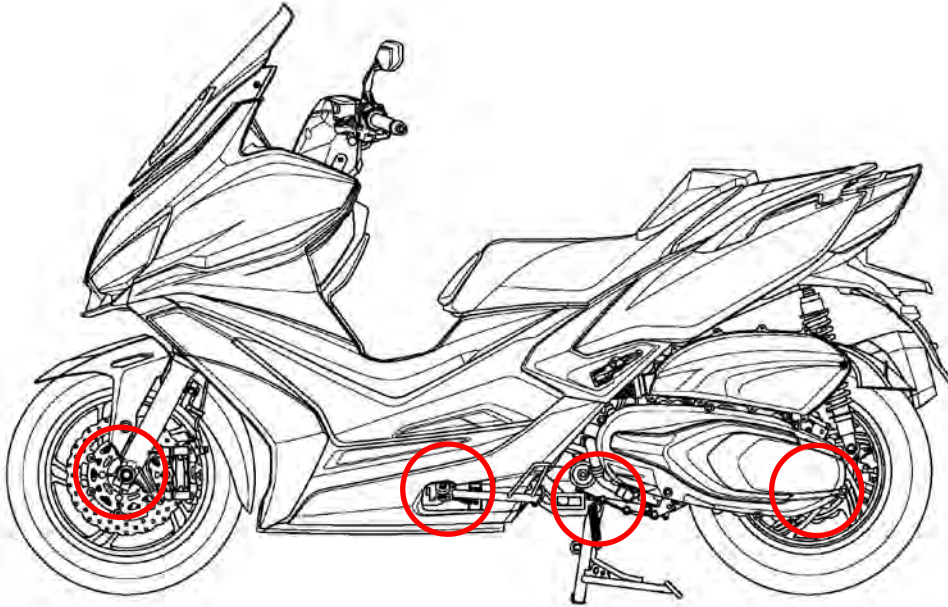

The frame lubrication points are listed below. Use general purpose grease. Apply clean engine oil or grease to cables and movable parts not specified. This will avoid abnormal noise and increase the durability of the motorcycle.

- Front Wheel Axle
- Side Stand Pivot
- Center Stand Pivot
- Rear Wheel axle

Side Stand

Interlock Function Check

Your scooter's side stand is not only necessary when you park, but it contains an important safety feature. This feature cuts-off the ignition if you try to ride the scooter when the side stand is down. Perform the following side stand inspection.

Place the vehicle on the center stand.

Unplug the three-pin side stand switch connector.

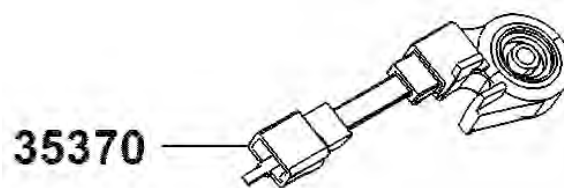
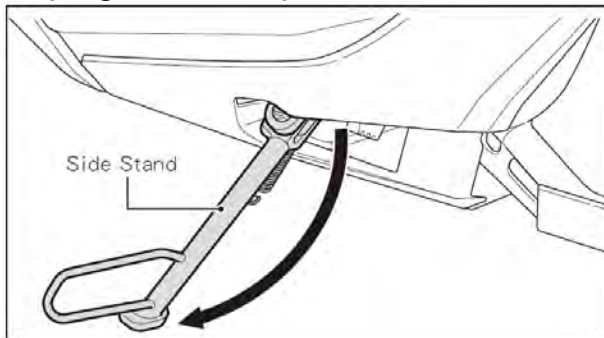

Use a digital multimeter to check for continuity.

With the side stand retracted there should be continuity between the yellow/green wire and the green wire terminals.

With the side stand extended there should be continuity between the yellow/black wire and the green wire terminals.

Spark Plug

remove the spark plug wire off of the spark plug.

Remove the connectors of the ignition coil.

Remove the two ignition coil mounting bolts and remove the ignition coil.

Clean off the area surrounding the spark plug with compressed air or a shop towel to make sure debris doesn't get into the combustion chamber when the spark plug is removed.

NOTE: Always wear safety glasses when using compressed air and never point it directly at yourself or anyone else.

Remove the spark plug with a spark plug with a 5/8 in socket.

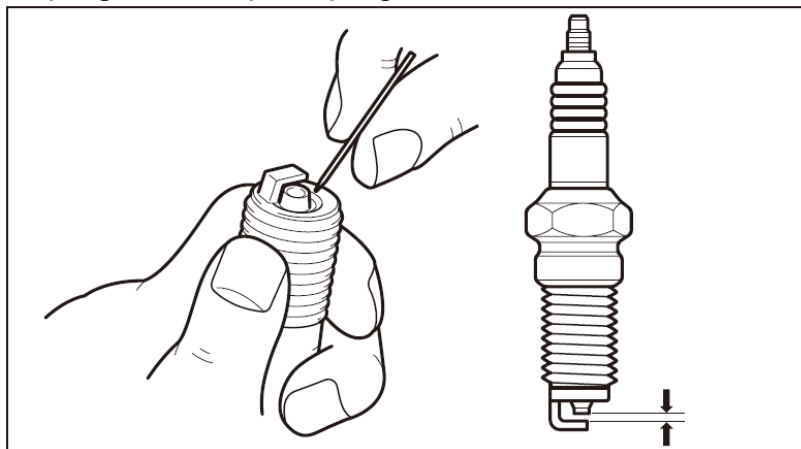

Spark plug	NGK CR7E
------------	----------

Check the spark plug to see if it is the correct type and gapped properly. If the spark plug is black and fouled, replace it.



If the spark plug center electrode or side electrode are corroded or damaged, or if the insulator is cracked, replace the plug.

Measure the gap with a wire-type thickness gauge. If the gap is incorrect, replace the spark plug.

Always check the gap of the spark plug before installation. Inspect the color of the porcelain nose of the spark plug. The color of the spark plug can indicate how the mixture is burning. A white colored plug shows a lean mixture, where a dark plug shows a rich mixture. Do not hesitate to replace a spark plug. Always replace a spark plug if any part of it is damaged.

Spark plug gap	0.7 - 0.8 mm
----------------	--------------

Do not over tighten the spark plug. The cylinder head is made out of soft metal, and it can be easily damaged.

Item	Torque
Spark plug	8 - 12 N-m (0.8 – 1.2 kgf-m)

Engine Compression Test

SAFETY FIRST: Protective gloves and eyewear are recommended at this point.

Remove the under cowl set. See the external topic for more information.

Before testing the compression make sure the cylinder head bolts are tightened securely and the valve clearance is specification.

See the Cylinder Head and Valve Clearance topics for more information.

Remove the spark plug. See the Spark Plug topic for more information.



Thread a compression tester into the spark plug hole hand tight. Hold the throttle all the way open. Crank the engine with the starter motor until the needle on the gauge stops rising. Do not crank the engine more than a few seconds.

Cylinder compression	15 kg/cm ²
----------------------	-----------------------

Low compression is an indication of excessive engine wear, possibly worn rings or poorly sealing valves, or maybe a tight valve with not enough valve clearance. High compression is possibly an indication of excessive carbon buildup on the piston or performance modifications.

Steering Inspection

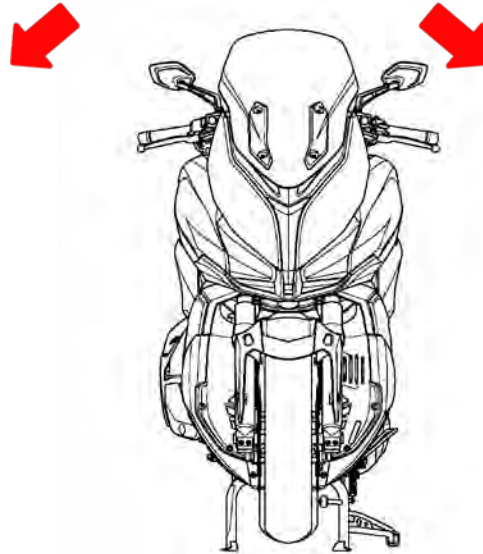

Raise the front wheel off the ground and check that the steering handlebar rotates freely. If the handlebar moves unevenly, binds, or has vertical movement, adjust the steering head bearing. See the Steering Stem Removal topic for more information.

Front Suspension Inspection

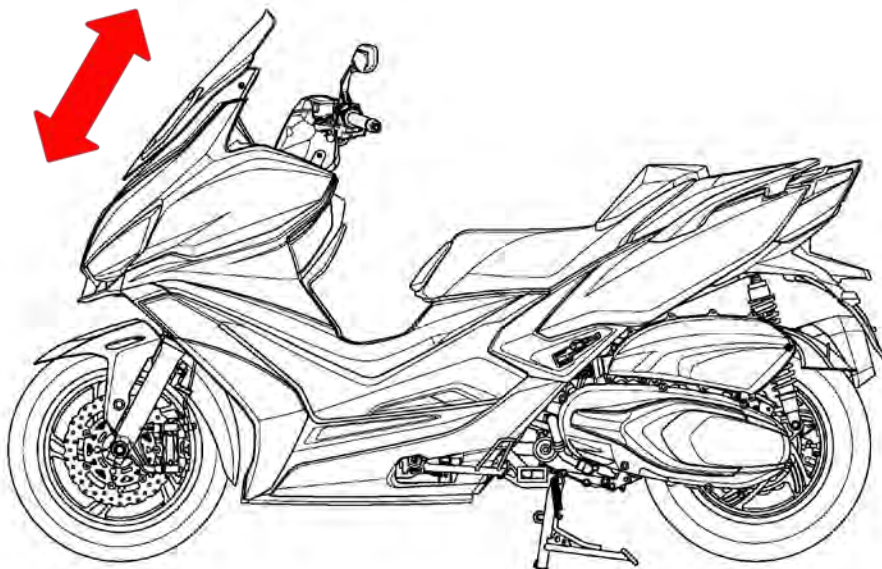

Check the action of the front shock absorbers by compressing them several times. Check the entire shock absorber assembly for oil leaks, looseness or damage.

Throttle Free Play Inspection

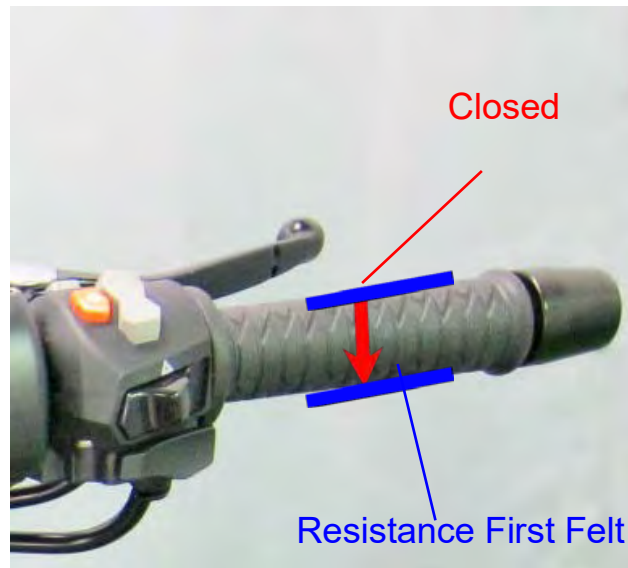

Check the throttle cable free play by gently rotating the throttle grip back until resistance is felt.

Throttle grip free play	2 ~ 6 mm
-------------------------	----------

Make sure the throttle moves smoothly and returns on its own. Start the engine and let it warm up. Turn the handlebars from side to side, if the engine rpm changes either the free play is too small or the throttle cables are not routed properly. Check and correct the cause.

Adjustments of the throttle free play can be made with the cable adjusters below the grip throttle.

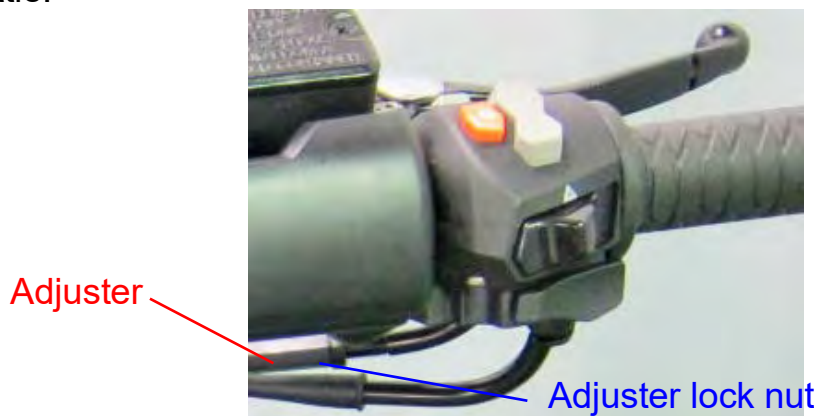

Loosen the throttle cable adjuster lock nut and turn the adjuster to achieve the specified free play.

When the free play has been moved into specification hold the adjuster in place and tighten the locknut securely.

Parking Brake Adjustment

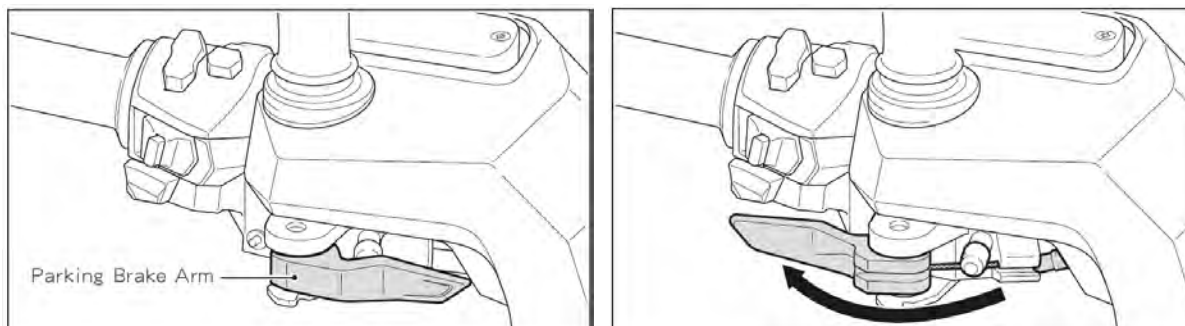

Release the fixed nut, and rotate the adjust nut to adjust the parking brake.



Note: Do not use the rear brake lock lever while driving.

Tires

Check grip between tire and ground and a normal tire pressure.

In case of a gripping anomaly, check tire pressure for normal reading using a pressure gauge.

Pressure measurements of cool tire:

With 1 rider

Front Wheel 2.0 kgf/cm² Rear Wheel 2.25 kgf/cm²

With 2 persons

Front Wheel 2.0 kgf/cm² Rear Wheel 2.25 kgf/cm²

Measure pattern depth at center of tread pattern. Measurements shall be taken at several points due to uneven wear.

Replace the tire if any of the measurements is lower than the service limit. Make sure the wheel is properly balanced when a new tire is replaced.

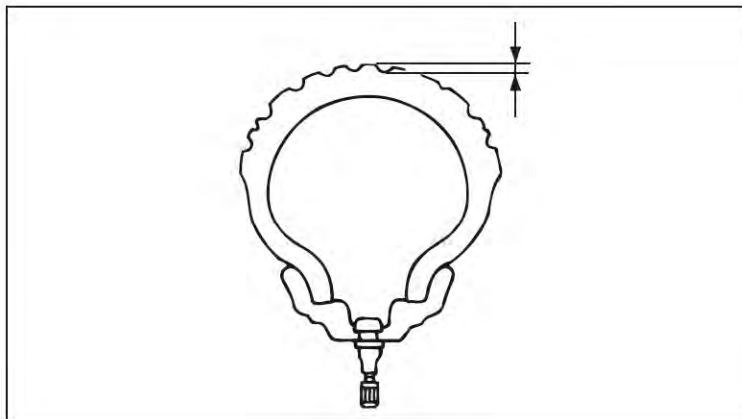

Service Limits:

Front Wheel 1.6 mm

Rear Wheel 2.0 mm

Check Tread Pattern for Wear

Check tires before each riding. In case of finding a transverse line (minimum pattern depth), nail or glass chip on the tire, or crack line on the side wall of tire, go to Kymco dealer for replacing with new one. Excessive wear of tire tread pattern will result in widened tread which is more prone to be punctured.

Tire Dimensions:

Front Tire Dimensions: 120/70-R15

Rear Tire Dimensions: 150/70-R14

Valve Clearance

The valve clearance specification is only relevant if the engine is cold.

Inspection

Remove the timing inspection cap from the left side of the engine. And rotate the crankshaft from the right side of the engine.

When installation, inspect the O-ring on the cap and replace it as needed.



Rotate the crankshaft to TDC mark.
And align the TDC mark at camshaft sprocket.



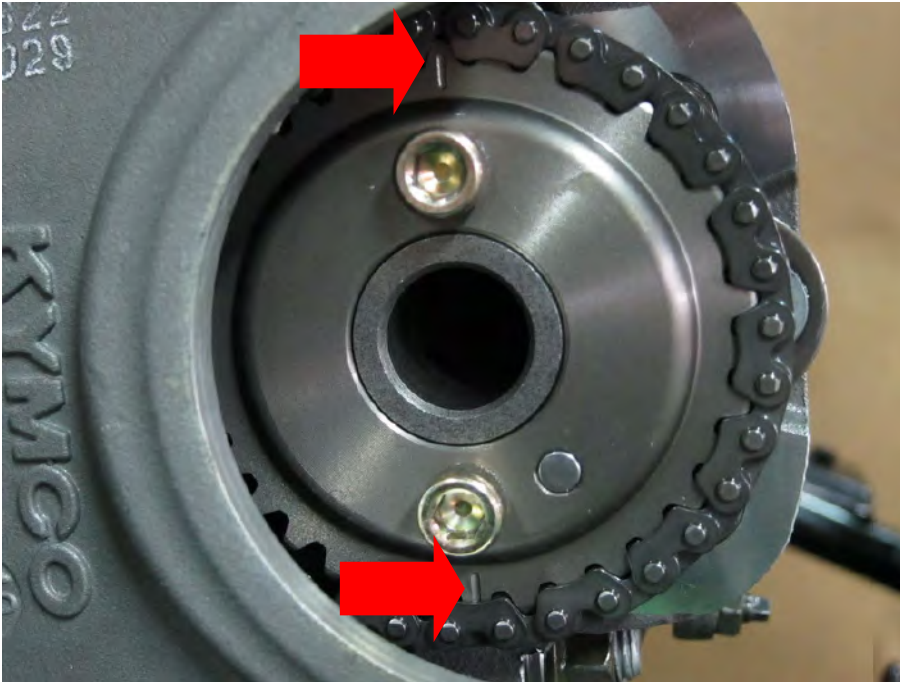

For correct engine timing the marks on the camshaft sprocket must be even with the cylinder head mating surface at the same time the "T" mark is lined up with the with the index notch in the timing inspection hole. Also the camshaft sprocket mounting boss should be visible above the cylinder head surface.

If this is not the case, rotate the crankshaft 360° clockwise until the "T" mark is once again aligned with the notch on the case cover.



Measure the valve clearance with a thickness feeler gauge. Insert the feeler gauge between the tappet adjusting screw and the valve stem. The clearance is correct when there is a light drag on the feeler gauge. The clearance is the same for the exhaust and intake valves. If the clearance is out of spec, move on to the adjustment section.

Valve clearance	IN: 0.10 mm	EX: 0.10 mm
------------------------	--------------------	--------------------

Adjustment



Use a tappet adjuster tool to adjust the valves.

SPECIAL TOOLS		
ITEM	TOOL NO.	DESCRIPTION
TAPPET ADJUSTER	A120E000012	Tappet adjustment

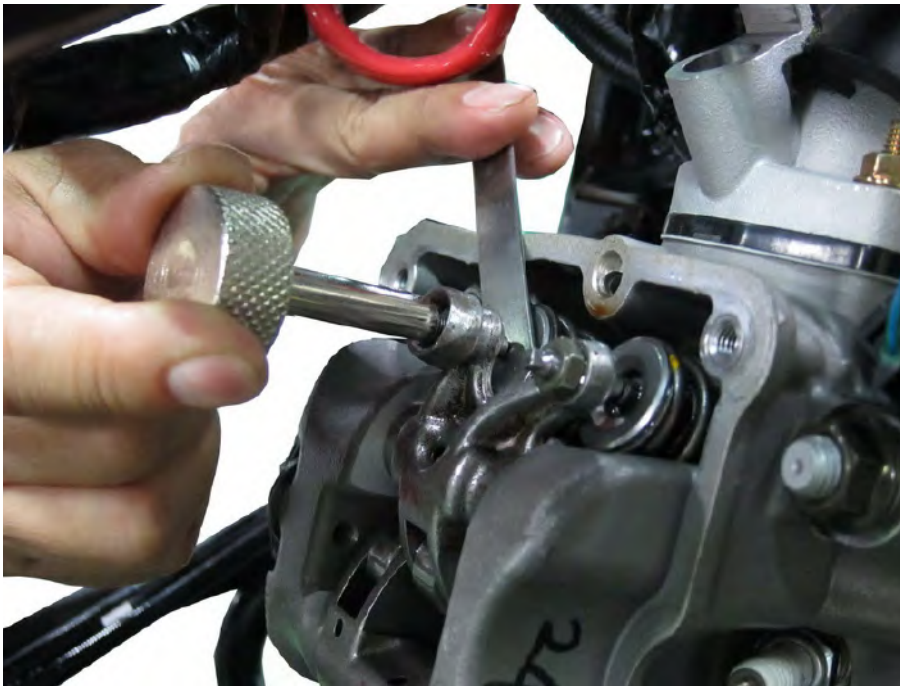

Place a 9 mm box end wrench over the locknut, and loosen the locknut. If the valve clearance is tight back out the valve tappet adjusting screws with the tappet adjustment tool. If the clearance is to loose turn in the adjusting screw until there is a light drag on the feeler gauge. Hold the adjusting screw locknut in place with the wrench to make sure it doesn't interfere with the adjustment.

Lubricate the tappet adjusting screw threads with fresh engine oil. Hold the adjuster in place and tighten the locknut. Always recheck the clearance after tightening the locknut. Also, recheck after turning the engine over a full 360°.

Item	Qty	Thread size (mm)	Torque		Remarks
			kgf-m	lb-ft	
Valve adjusting lock nut	4	5	0.7-1.1	5.06-7.96	Apply oil to thread



Make sure the O-rings on the timing plugs are in good condition. Replace it as needed. Install the timing inspection to the right side of the engine. Tighten the caps securely but not overly with a large flat blade screwdriver.

3.External Components

This chapter covers the location and servicing of the external components for the KYMCO XCITING S 400 model.

General Instructions.....	3-2
Windscreen Cover/Windscreen/ Front Meter Cover.....	3-4
Leg Shield Lid / Front Cover Set	3-5
Back Mirror/ Mats Of Floor/ Side Cover Set.....	3-6
Under Cowl / Under Cover/ Panel Floor	3-7
Center Cover Set/ Side Board Set/Meter Cover Set	3-8
Leg Shield Assy	3-9
Up And Low Handle Cover	3-9
Front Inner Fender/ Front Fender Assy.	3-11
Seat	3-12
Battery Cover/ Back Carriers/ Rear Seat	3-13
Luggage Box/ Rear Center Cover	3-14
Body Cover Set	3-15
Heat Shield	3-16
Exhaust System	3-17
Muffler	3-18
Exhaust Pipe	3-19
O2 Sensor	3-20
Side Stand	3-21
Center Stand	3-22

General Instructions

- When removing frame covers, use care not to pull them by force because the cover joint claws may be damaged.
- Make sure to route cables and harnesses according to the Cable & Harness Routing.

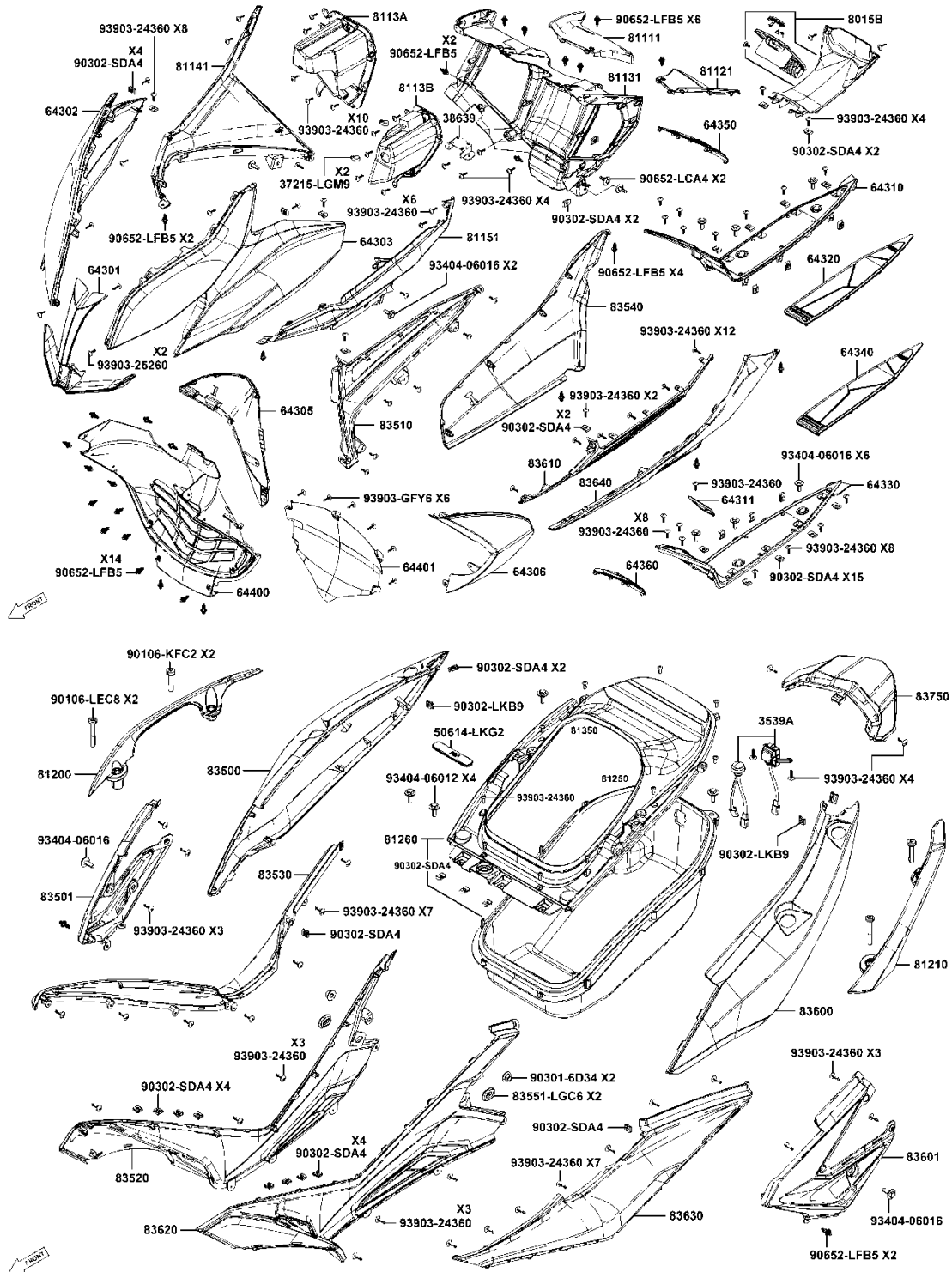

Dismantled and assembly order

Follow the dismantled order as below illustration.

Assembly is reverse of dismantled order.

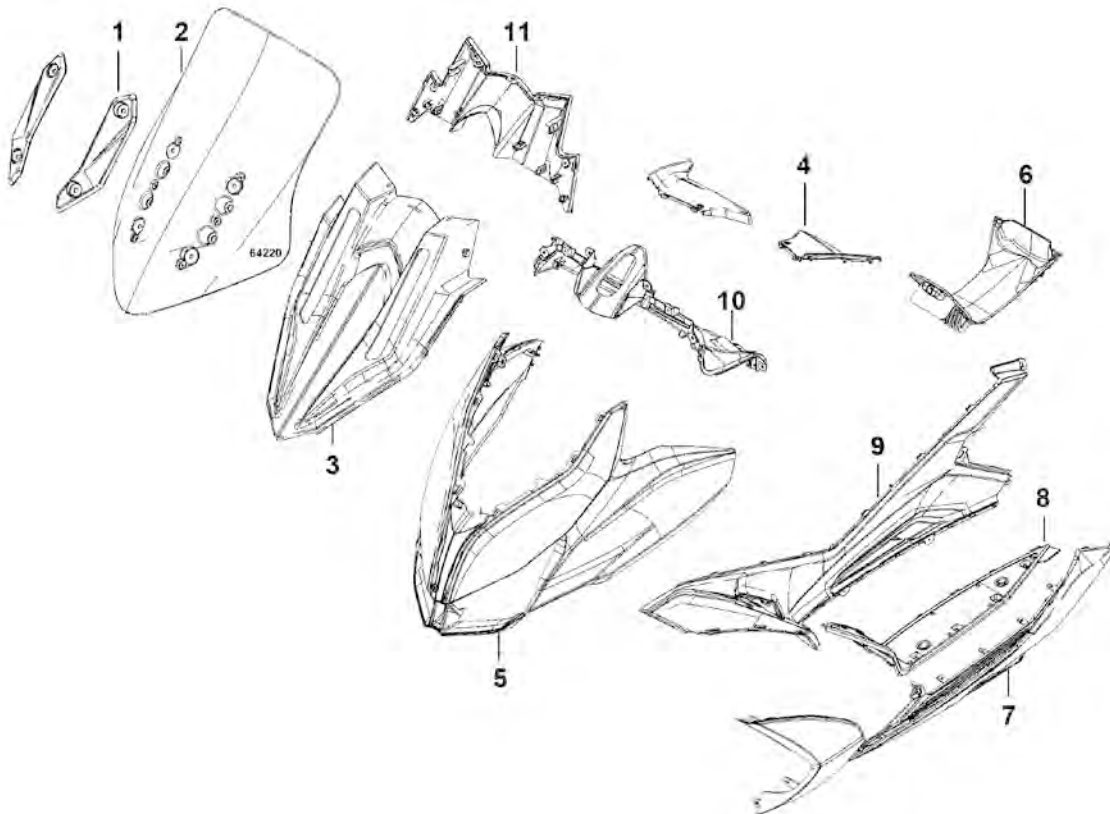

Note:

- When removing frame covers, use care not to pull them by force because the cover joint claws may be damaged.
- Make sure to route cables and harnesses according to the Cable & Harness Routing.

Windscreen Cover Removal

Remove four fasteners and remove the windscreen covers.

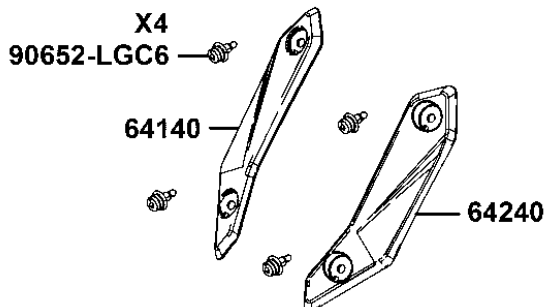
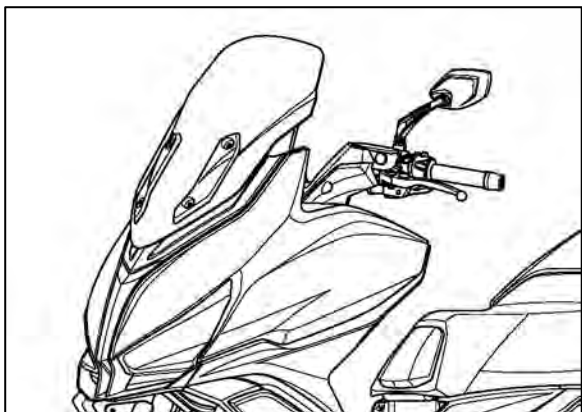

Windscreen Removal

Remove four bolts and remove the windscreen.

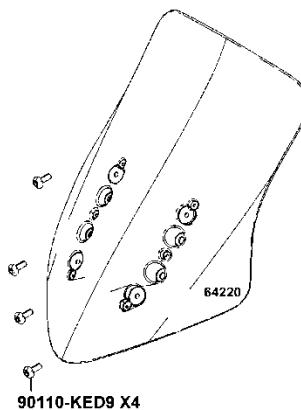
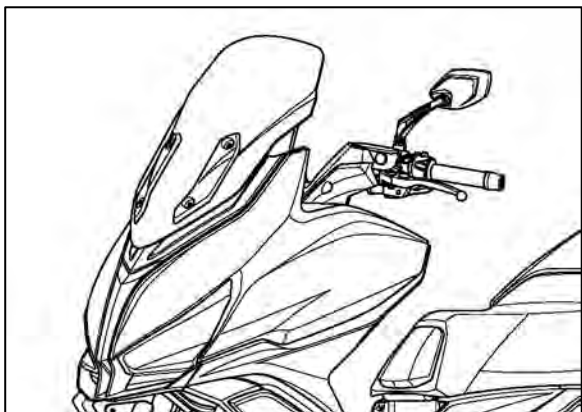

Front Meter Cover Removal

Remove screws and remove the front meter cover.

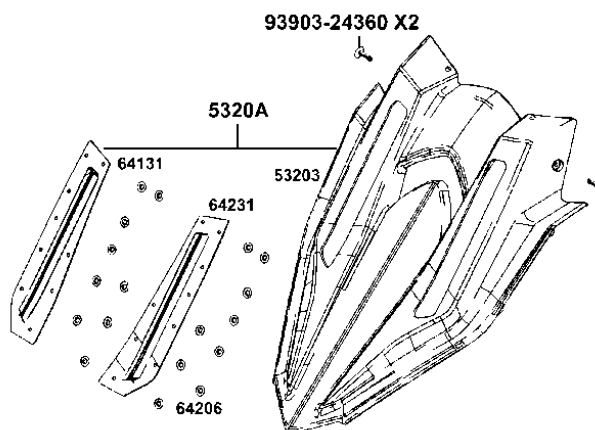

Leg Shield Lid Removal

Remove two fasteners and remove the right and left leg shield lids.

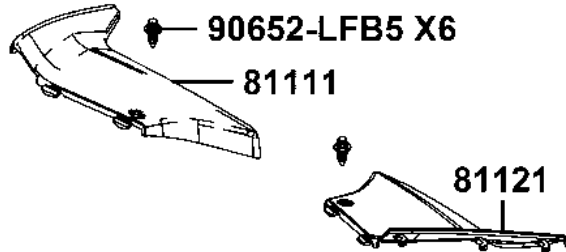

Front Cover Set Removal

Remove nuts, screws and coupler, remove the front cover set.

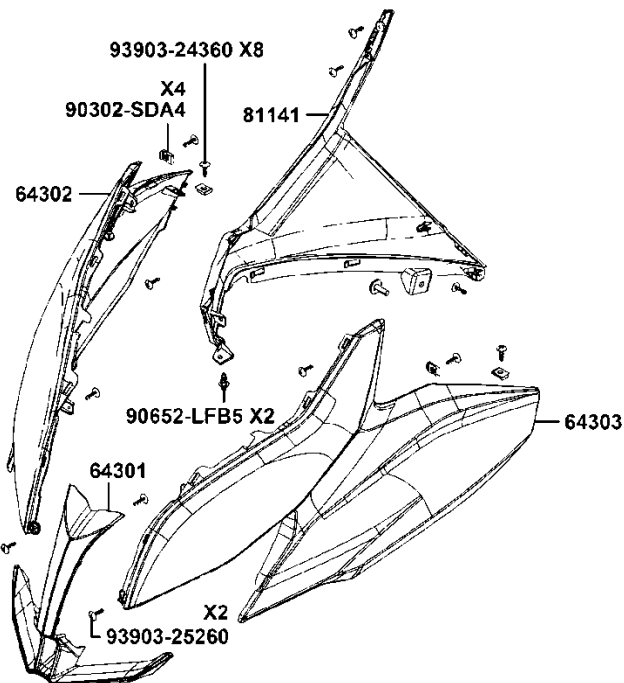

Back Mirror Removal

Remove four bolts and remove the back mirrors.

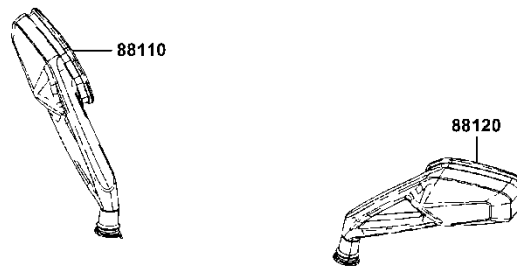
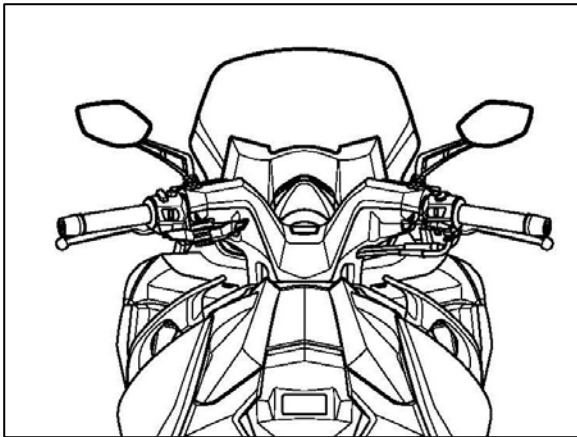

Mats Of Floor Removal

Remove four mats of floor.

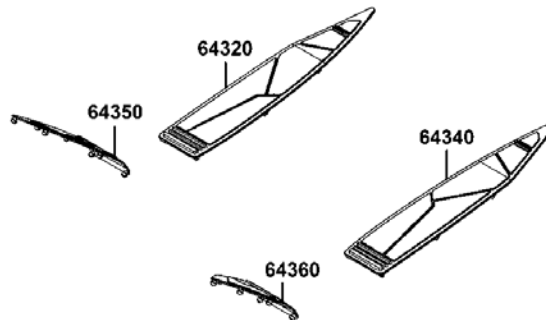

Side Cover Set Removal

Remove screws, fasteners and remove the left and right side cover sets.

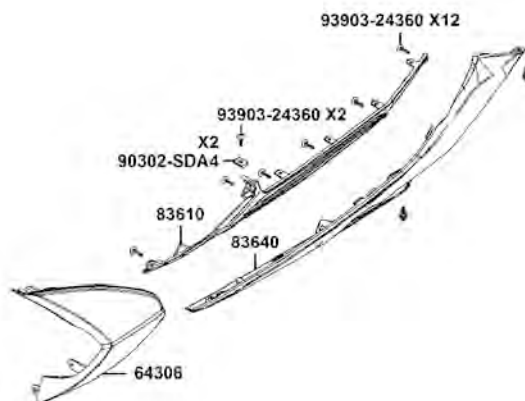

Under Cowl Removal

Remove 4 screws, 6 small fasteners and remove the left and right side skirts set.

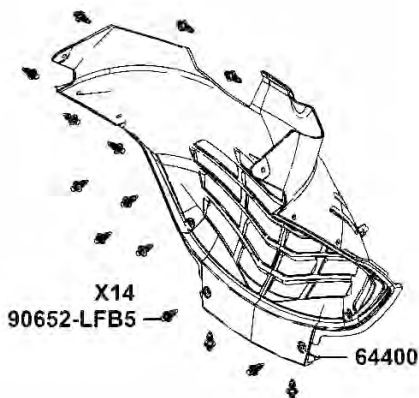

Under Cover Removal

Remove the 4 bolts and remove the under cover.

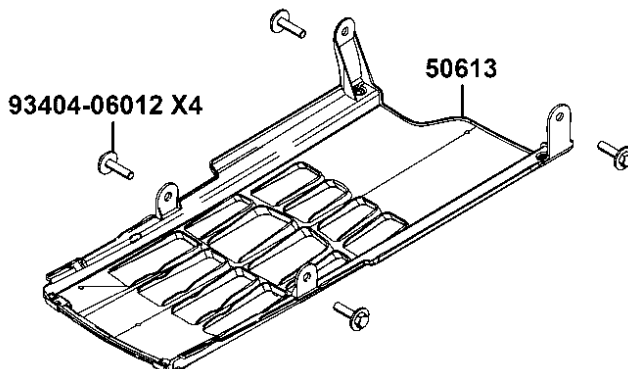

Panel Floor Removal

Remove screws, bolts, remove the right and left panel floor.

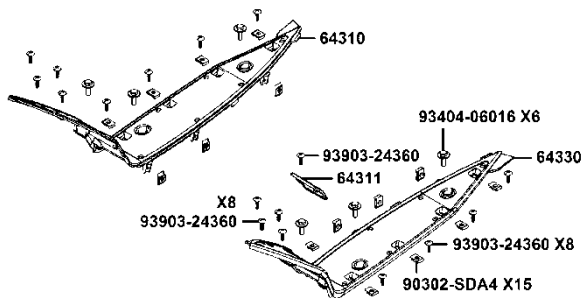

Center Cover Set Removal

Open the fuel cap lid and remove screws and remove the center cover set.

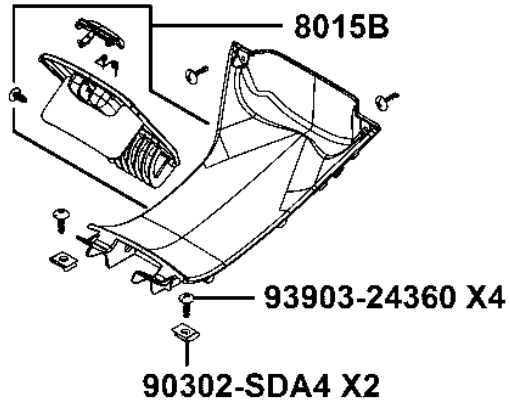

Side Board Set Removal

Remove fasteners, screws and couplers and remove the right and left side boards.

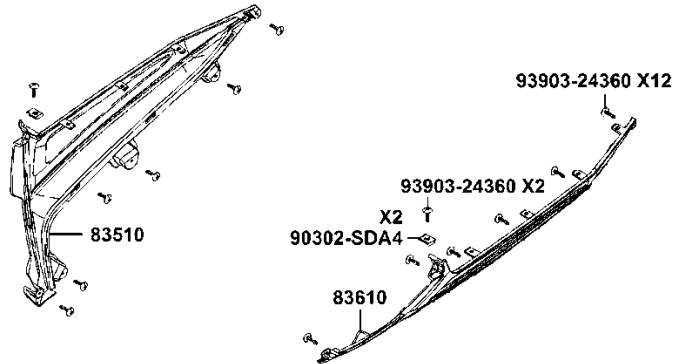

Meter Cover Set Removal

Remove couplers. Remove fasteners, screws, bolts and remove the meter cover.

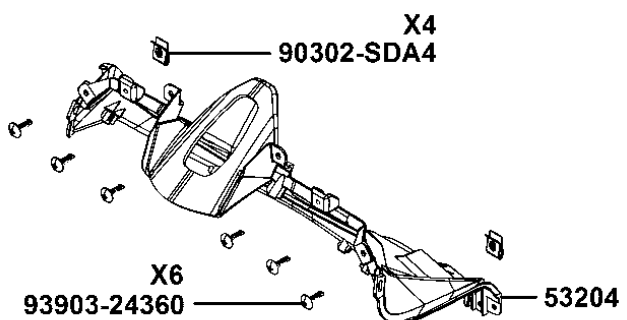

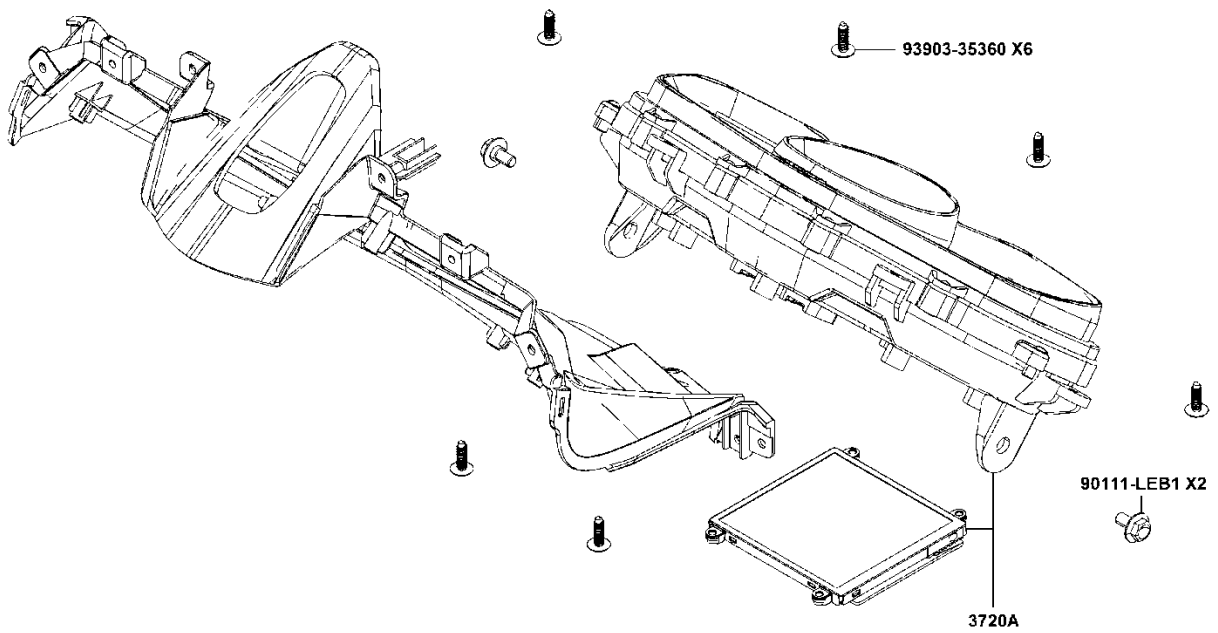

Leg Shield Assy. Removal

Remove the screw, rotate and remove the main switch plate.

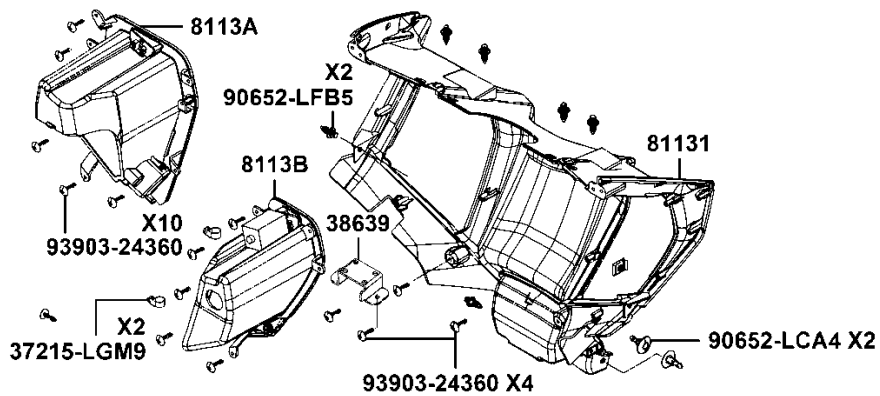

Up And Low Handle Cover Removal

Remove the top handle cover.

Remove the bolts, screws and remove the up handle cover.



Remove the bolts, screws.

Remove throttle and parking brake cables and remove the low handle cover.

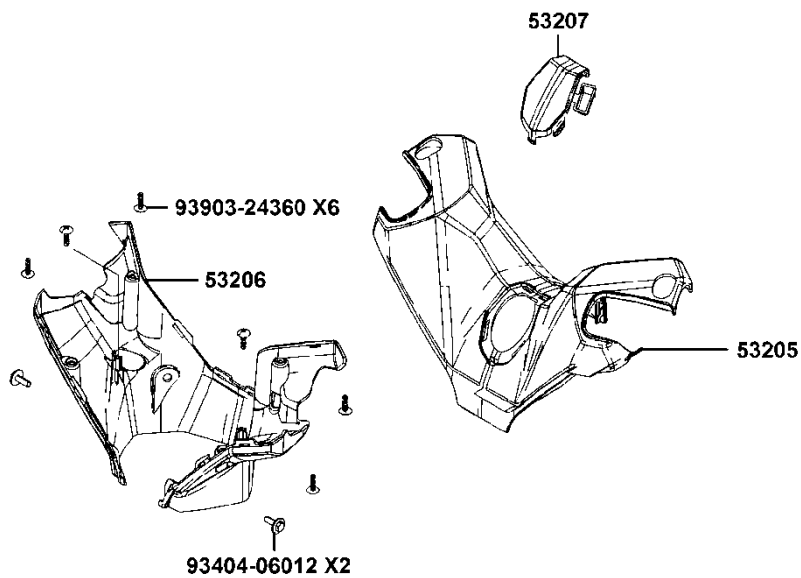

Front Inner Fender Removal

Remove screws and remove the front inner fender.

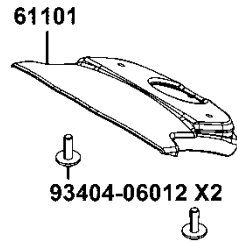

Front Fender Assy. Removal

Remove the bolts, plates and reflectors.
Remove the front fender assembly.

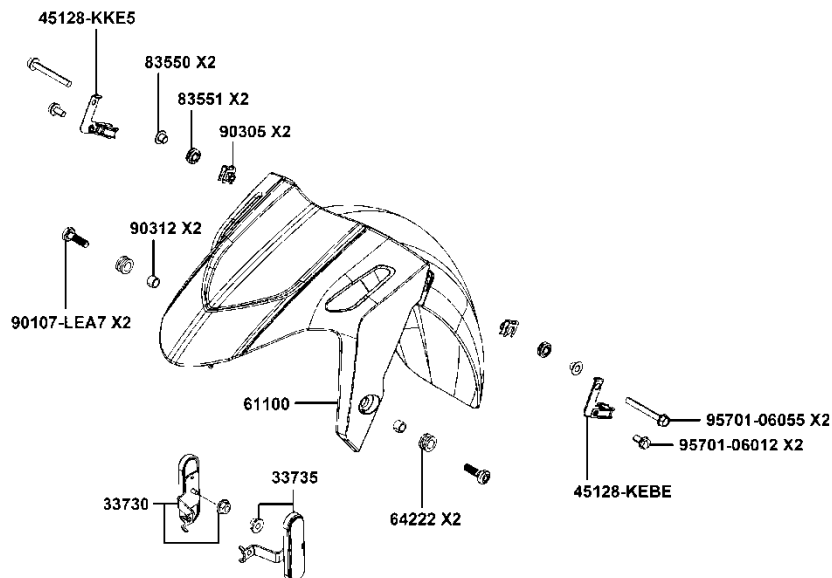

Seat Removal

Turn the ignition switch counter clockwise to open the seat.

Lift up the seat and remove 2 nuts and remove the seat.

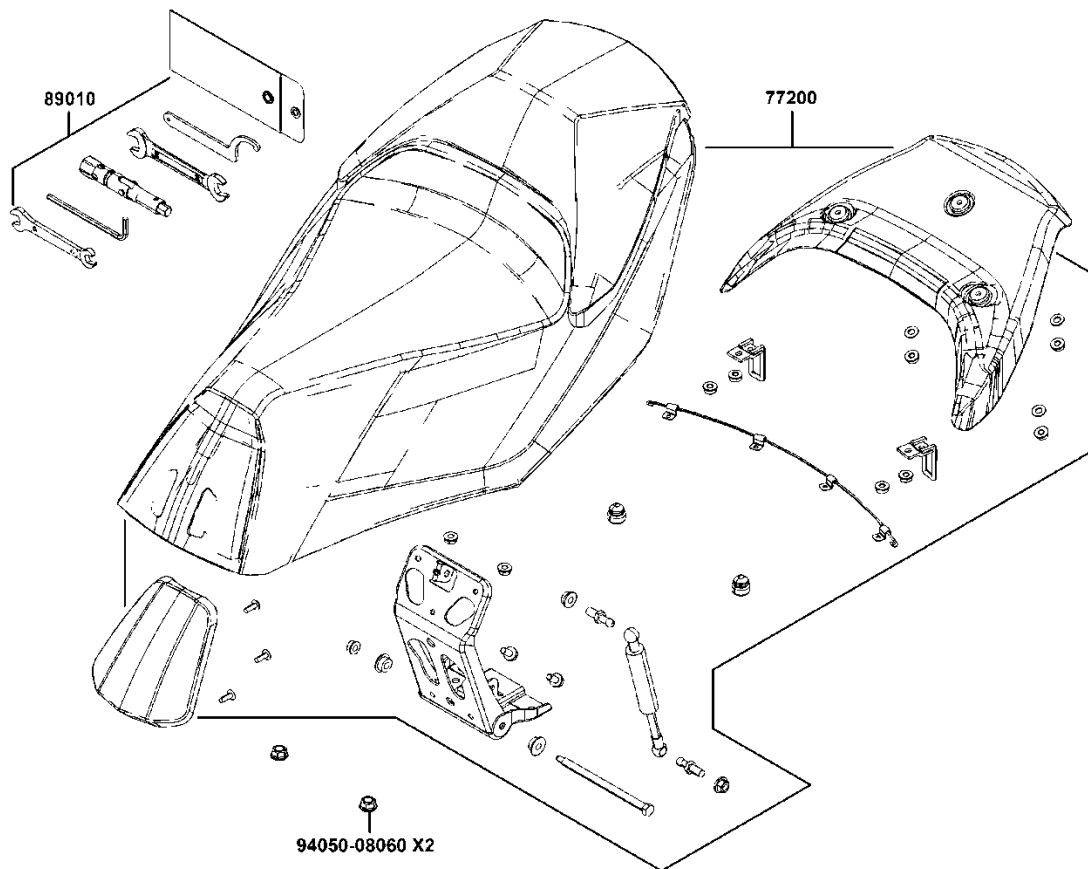
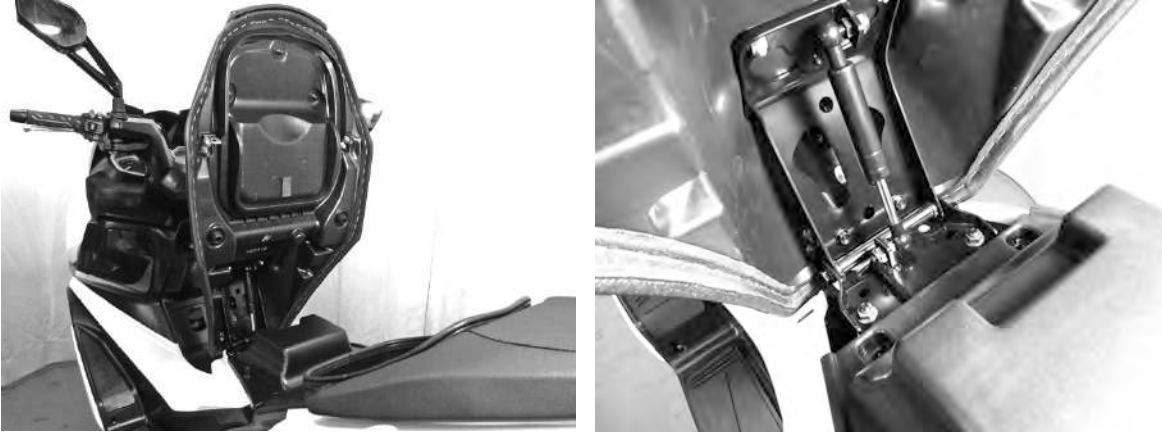

Battery Cover Removal

Remove screws, nuts, remove the battery cover.

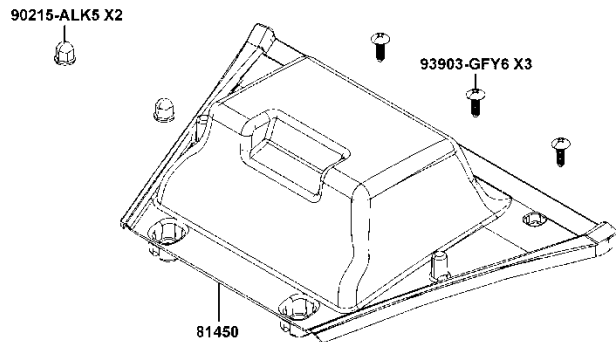

Back Carriers Removal

Remove 4 bolts and remove the right and left back carriers.

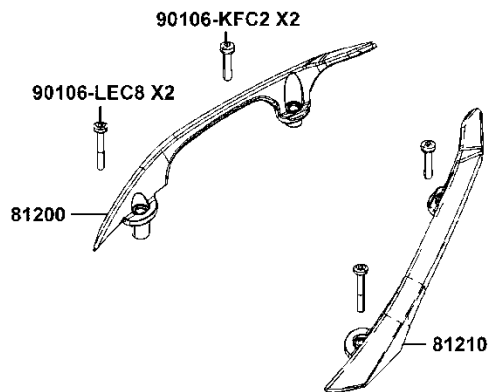
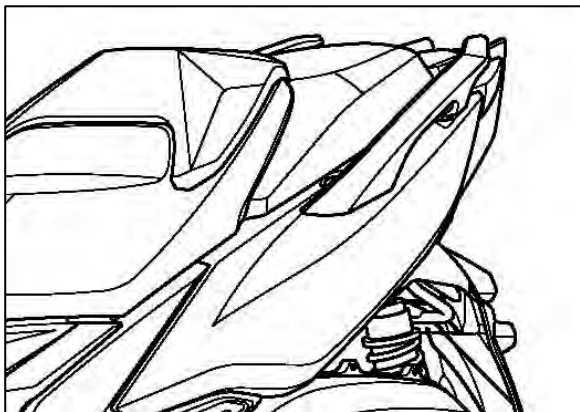

Rear Seat Removal

Remove 4 bolts and remove the right and left rear seat.

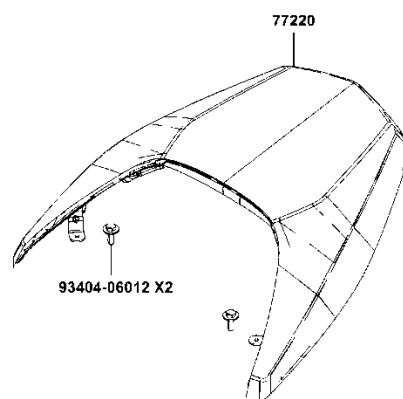

Luggage Box Removal

Remove screws, bolts and couplers then remove the luggage box.

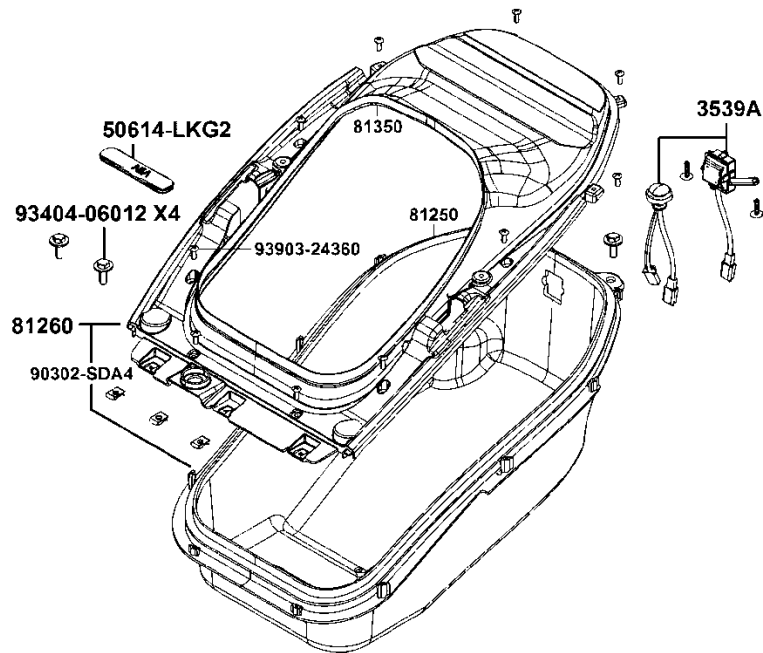
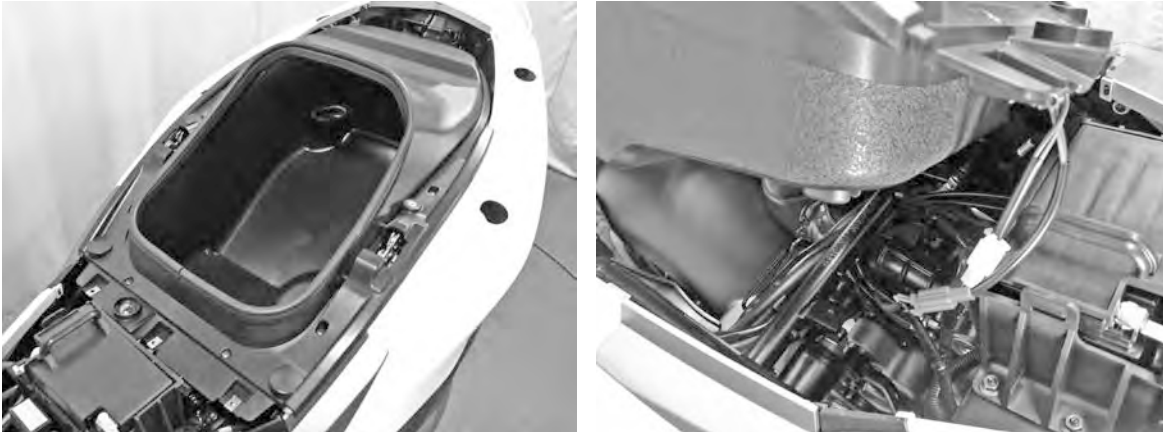

Rear Center Cover Removal

Remove fasteners and remove the rear center cover.

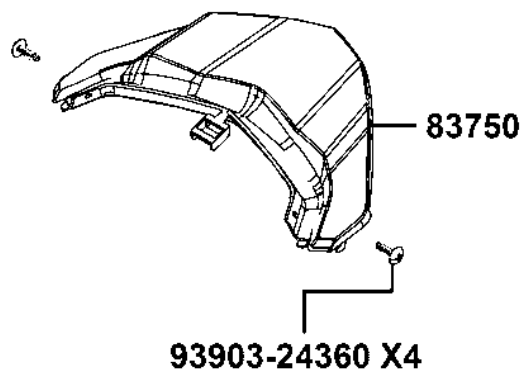

Body Cover Set Removal

Remove fasteners, bolts, screws, coupler and remove the body cover set.

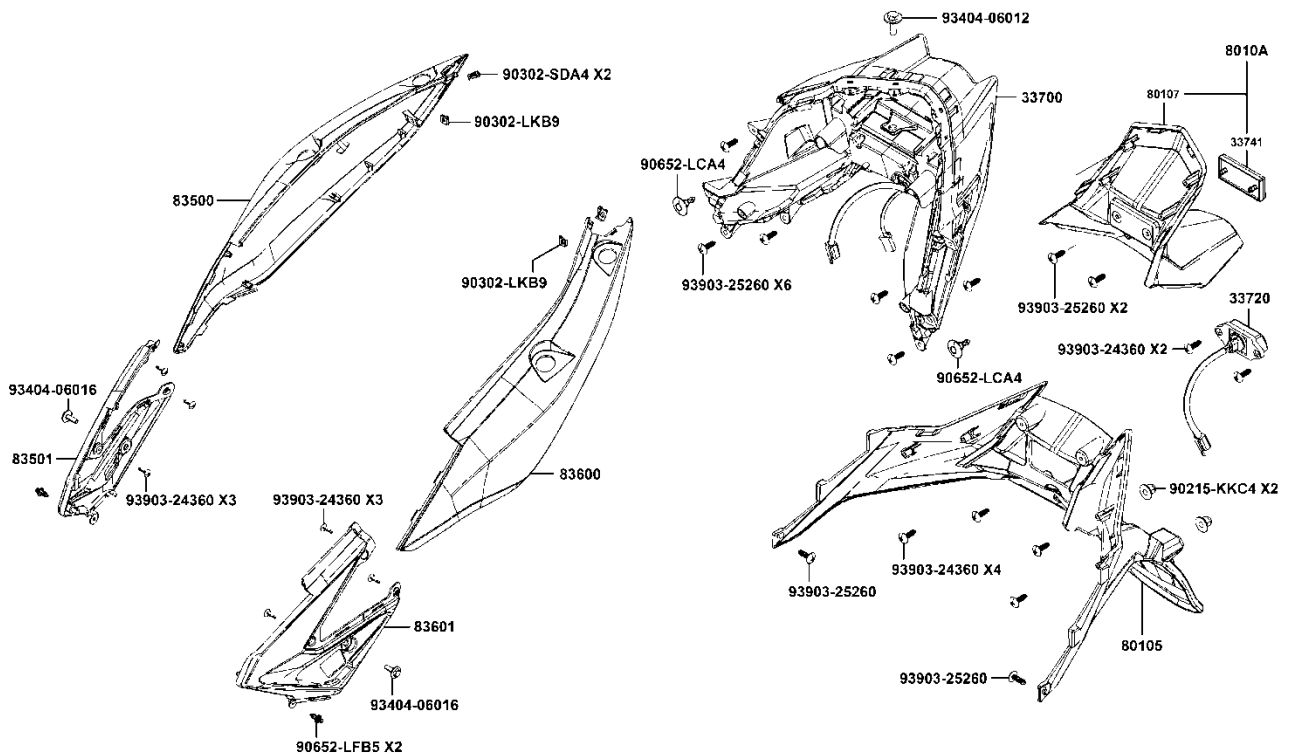

Heat Shield Removal

Remove bolts and remove the heat shields.



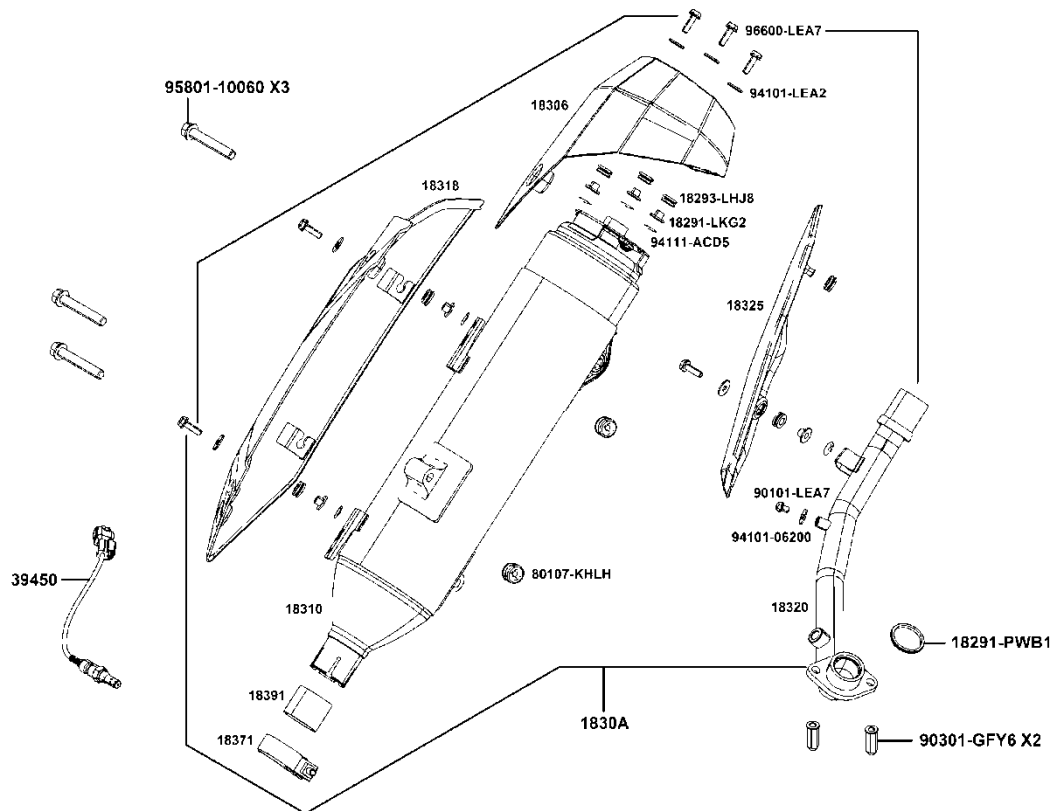

Exhaust System

SAFETY FIRST: Protective gloves and eyewear are recommended at this point.

Troubleshooting

Noisy exhaust muffler

- Damaged exhaust muffler
- Exhaust muffler joint air leaks

Lack of power

- Caved exhaust muffler
- Clogged exhaust muffler
- Exhaust muffler air leaks

Muffler Removal

Remove bolts of the muffler.

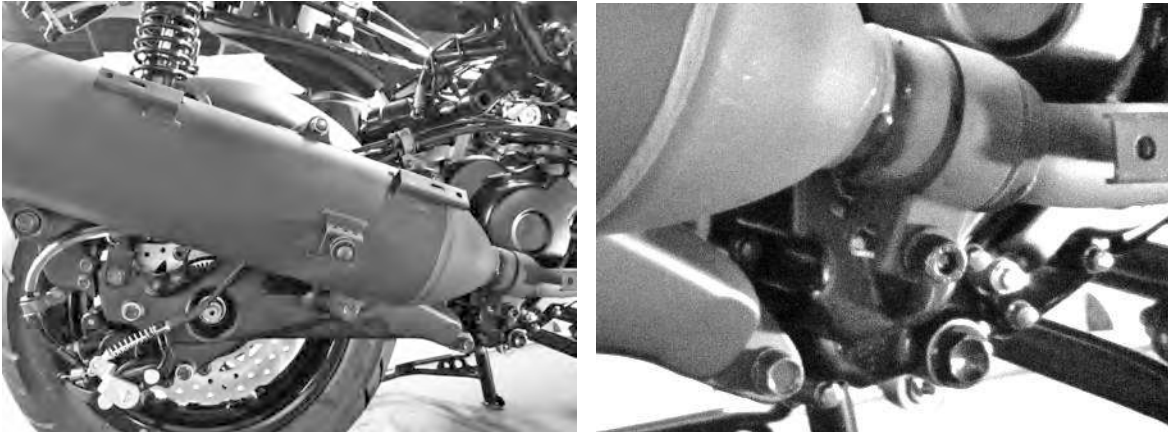

Remove the muffler.

Replace the new exhaust pipe gasket(18391) when installation.

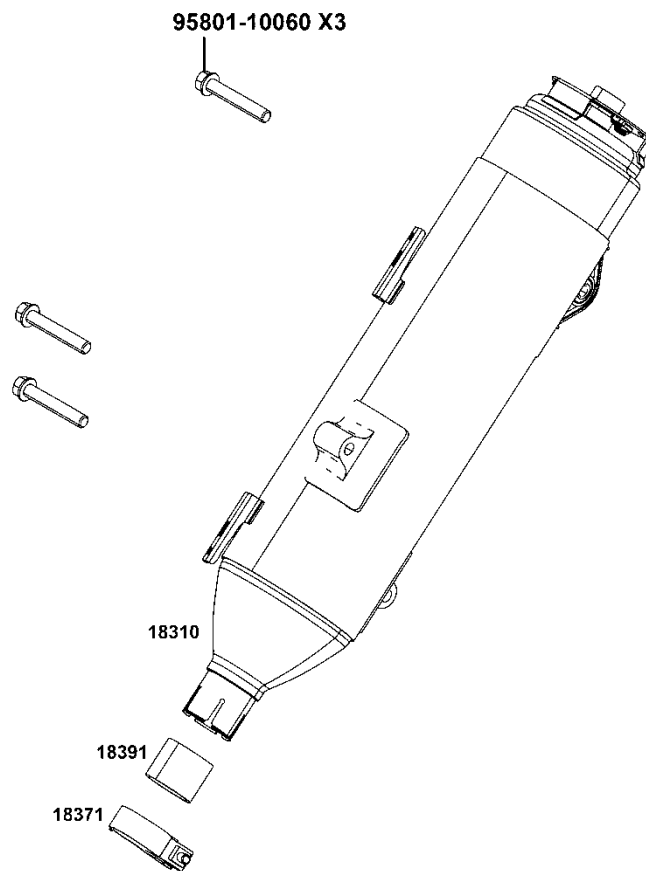

Exhaust Pipe Removal

Unplug the O² sensor connector.
Remove nuts of the exhaust pipe.



Remove the exhaust pipe.
Replace the new exhaust pipe gasket(18291) when installation.

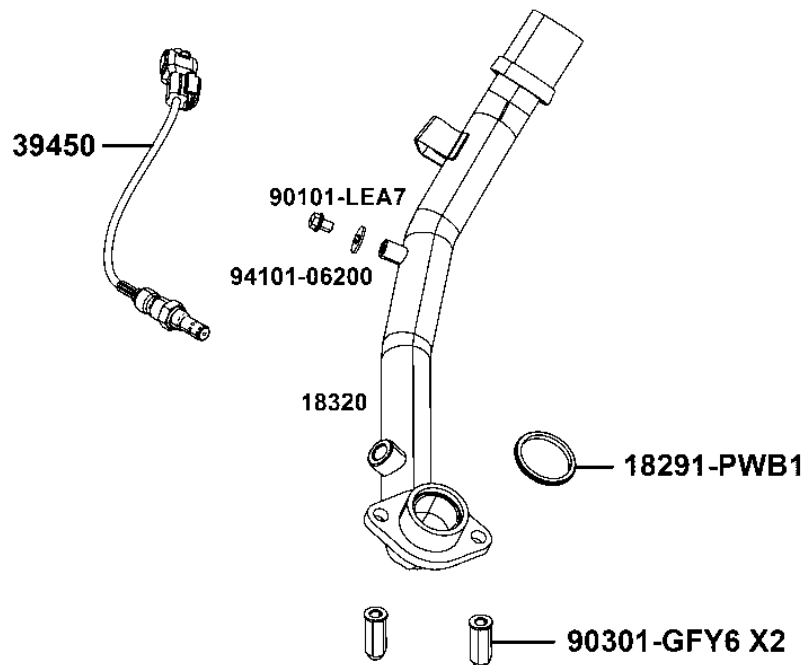

O₂ Sensor Removal

Remove the O₂ sensor with a 17 mm wrench. Use care not to pinch the wires.

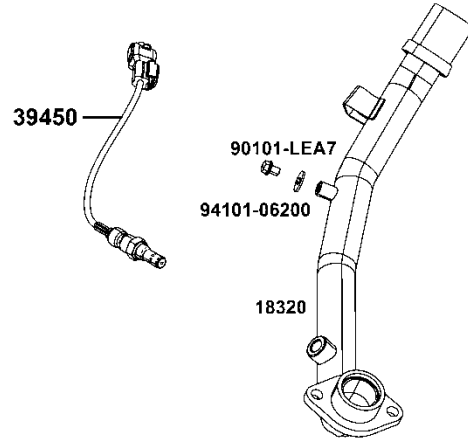

Installation torque: 2~3 kgf-m (20~30 N-m)

Apply anti-seize compound to the threads of the O₂ sensor. Install the O₂ sensor and tighten it to specification with a 17 mm wrench. Use care not to pinch the wires.

The O₂ sensor issues signal to ECU when the temperature is over 350°C while the engine is running.

Test the O₂ sensor at room temperature.

Use a digital multimeter set to ohms of resistance to inspect the O₂ sensor.

Measure the resistance between the white wire terminals of the O₂ sensor connector. Replace the O₂ sensor if the reading is out of specification.

ITEM	SPECIFICATIONS
O ₂ heater sensor resistance (at 20°C/68°F)	12 - 18 Ω (engine warming condition)

Side Stand Removal

Unplug the three-pin side stand switch connector.

Remove the spring, side stand bolt, switch, and side stand.

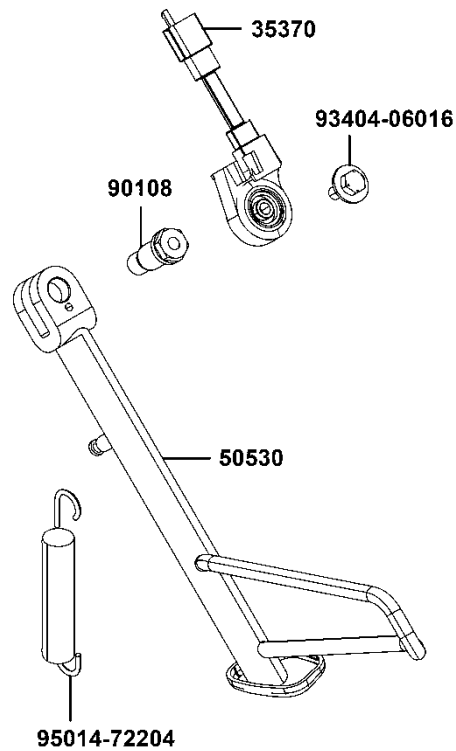

Center Stand Removal

Lift up the vehicle by a jack carefully.

Remove the center stand spring with a spring puller.

Remove the nuts and bolts. Remove the center stand.

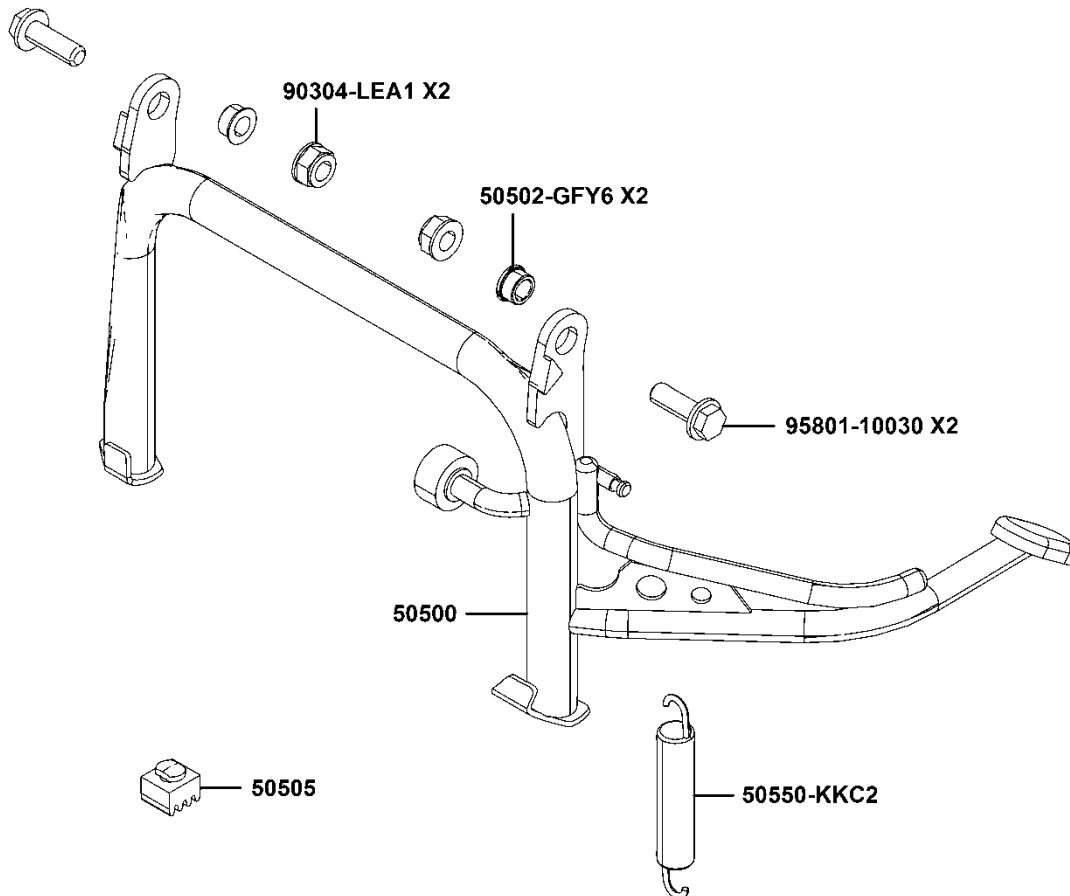

Engine

This chapter covers the location and servicing of the engine components for the KYMCO Xciting 400i and Xciting S 400.

- Engine Removal4-4~4-12
- Cylinder Head Cover4-13~4-17
- Camshaft.....4-18~4-32
- Valves4-33~4-44
- Cylinder and Piston4-45~4-61
- Generator4-62~4-82
- Oil Pump4-83~4-89
- Crankcase4-90~4-102
- Camshaft.....4-103~4-106
- Engine Installation.....4-107~4-115

GENERAL INSTRUCTIONS

Lubrication System

The maintenance of lubrication system can be performed with the engine installed in the frame. Use care when removing and installing the oil pump not to allow dust and foreign matters to enter the engine and oil line.

Do not attempt to disassemble the oil pump. The oil pump must be replaced as a set when it reaches its service limit.

After the oil pump is installed, check each part for oil leaks.

TROUBLESHOOTING

Oil level too low

1. Natural oil consumption
2. Oil leaks
3. Worn or poorly installed piston rings
4. Worn valve guide or seal

4. Engine

Poor lubrication pressure

1. Oil level too low
2. Clogged filter or oil passages
3. No use the specified oil

Cylinder Head, Camshaft, and Valves

- The cylinder head can be serviced with the engine installed in the frame. Coolant in the radiator and water hoses must be drained.
- When assembling, apply molybdenum disulfide grease or engine oil to the valve guide movable parts and valve arm sliding surfaces for initial lubrication.
- The valve rocker arms are lubricated by engine oil through the engine oil passages. Clean and unclog the oil passages before assembling the cylinder head.
- After disassembly, clean the removed parts and dry them with compressed air before inspection.
- After removal, mark and arrange the removed parts in order. When assembling, install them in the reverse order of removal.

TROUBLESHOOTING

- The poor cylinder head operation can be diagnosed by a compression test or by tracing engine top-end noises.

Poor performance at idle speed

- Compression too low

Compression too low

- Incorrect valve clearance adjustment
- Burned or bent valves
- Incorrect valve timing
- Broken valve spring
- Poor valve and seat contact
- Leaking cylinder head gasket
- Warped or cracked cylinder head
- Poorly installed spark plug

4. Engine

Compression too high

- Excessive carbon build-up in combustion chamber

Abnormal noise

- Incorrect valve clearance adjustment
- Sticking valve or broken valve spring
- Damaged or worn camshaft
- Worn cam chain tensioner
- Worn camshaft and rocker arm

White smoke from exhaust muffler

- Worn valve stem or valve guide
- Damaged valve stem oil seal

Cylinder and Piston

- The cylinder and piston cannot be serviced with the engine installed in the frame.
- After disassembly, clean the removed parts and dry them with compressed air before inspection.
- If replacing the piston or cylinder, they must be changed as a pair.

TROUBLESHOOTING

Compression too low or uneven compression

- Worn, stuck or broken piston rings
- Worn or damaged cylinder and piston

Compression too high

- Excessive carbon build-up in combustion chamber or on piston head.

Excessive smoke from exhaust muffler

- Worn or damaged piston rings
- Worn or damaged cylinder and piston

Abnormal noisy piston

- Worn cylinder, piston and piston rings
- Worn piston pin hole and piston pin

Engine Removal

SAFETY FIRST: Protective gloves and eyewear are recommended at this point.

- A floor jack or other adjustable support is required to support and maneuver the engine. Be careful not to damage the scooter body, cables and wires during engine removal.
- Use shop towels to protect the scooter body during engine removal.

Place the scooter on the center stand.

Remove the following external components:

- . Seat
- . Luggage Box
- . Center Cover
- . Front Cover
- . Front Lower Cover
- . Foot Skirt
- . Rear Carrier
- . Body Cover
- . Under Cover

3. Engine > Engine Removal



The regulator/rectifier is located on the right side of the vehicle.



Disconnect the generator 3-pin connector.



Disconnect the crank position sensor wire coupler.



Remove the bolts.
And remove the oil catcher.(Xciting S 400)

3. Engine > Engine Removal



Unplug the water temperature sensor.



Pull back the rubber starter motor lead cover.

3. Engine > Engine Removal



Remove the starter motor lead nut with a 10 mm wrench. Free the cable lead from the starter motor. Thread the nut back on to keep track of it.



Loosen the fuel hose stay bolt with an 8 mm socket. Free the fuel hose stay from the cylinder head cover.

3. Engine > Engine Removal



Loosen the water pump hose clamp with a #2 Phillips screwdriver. Slide up the clamp and free the coolant hose from the water pump. Allow any remaining coolant to drain into a suitable container.



Loosen the thermostat hose clamp with a #2 Phillips screwdriver. Slide up the clamp and free the coolant hose from the thermostat. Allow any remaining coolant to drain into a suitable container.



Squeeze the air bleed hose clamp with needle nose pliers and slide back the clamp. Free the air bleed hose from the thermostat.

3. Engine > Engine Removal



Disconnect the main engine ground wire. Free the engine ground from the left side of the engine.



Unplug the oil pressure switch wire at the bullet connector. The oil pressure switch is located below the cylinder.



Free the wiring harness from its guide above the intake pipe.

3. Engine > Engine Removal



Support the engine with a suitable jack or stand.

Remove the rear shock absorbers.



Loosen the engine mounting bracket damper nut with a 14 mm socket.
Remove the nut and washer.



Hold the engine mounting bolts with a 14 mm wrench and loosen the nuts with a 19 mm socket.

3. Engine > Engine Removal



Remove the engine mounting nuts and bolts from both sides.



Loosen the engine mounting bracket damper bolt and nut with a 17 mm wrench for the nut and a 14 mm socket for the bolt.



Remove the engine mounting bracket damper bolt and nut.

3. Engine > Engine Removal



Remove the engine mounting bracket.



Remove the engine mounting bracket damper assembly.

Carefully move the engine back and separate it from the chassis.

3. Engine > Cylinder Head Cover

Cylinder Head Cover

SAFETY FIRST: Protective gloves and eyewear are recommended at this point.

Removal



Squeeze the breather hose clamp with needle nose pliers and slide it back. Remove the breather hose from the cylinder head cover.

3. Engine > Cylinder Head Cover



Free the fuel hose stay from the cylinder head cover.



Loosen the four cylinder head cover bolts with a 10 mm socket.
Remove the cylinder head cover bolts with washers and grommets.
Note the gold colored and longer bolts are on the right side.

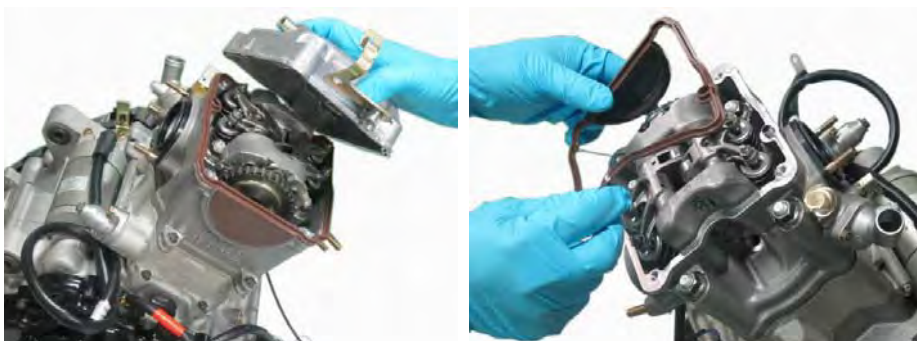

Remove the cylinder head cover and gasket.
Discard the gasket and replace it with a new item on installation.

3. Engine > Cylinder Head Cover

Installation



Fit the cylinder head cover gasket onto the cylinder head. Make sure the projection fits into the groove in front of the camshaft sprocket correctly.



Install the cylinder head cover over the gasket. Make sure the ridge on the gasket fits into the groove on the cylinder head cover correctly. Align the bolt holes and dowel pin.

3. Engine > Cylinder Head Cover

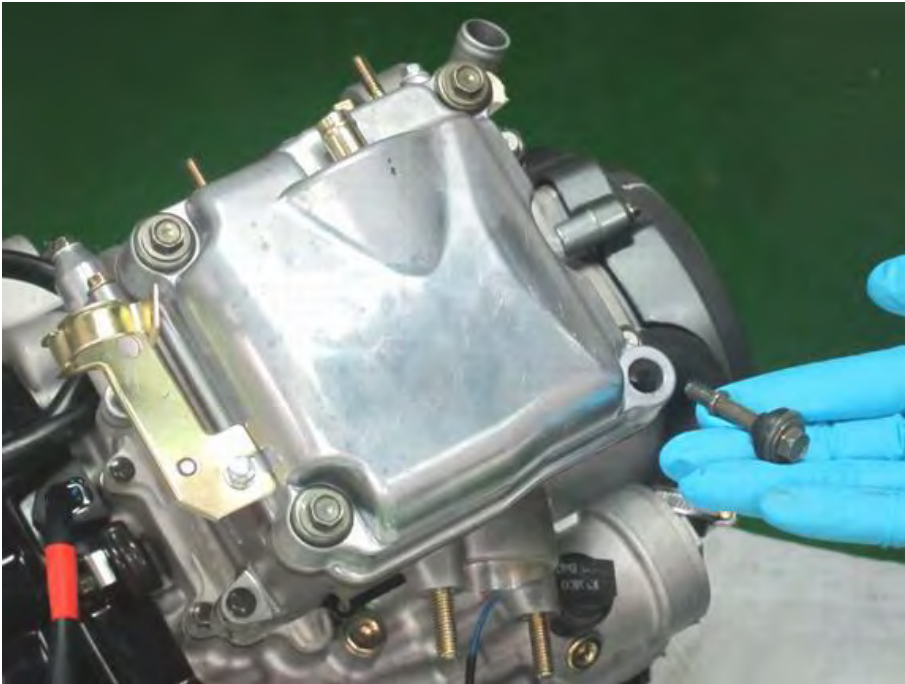

Coat the cylinder head cover bolt seals in fresh engine oil. Insert the cylinder head cover bolts with grommet seals and washers. Note the gold colored and longer bolts go on the right side.

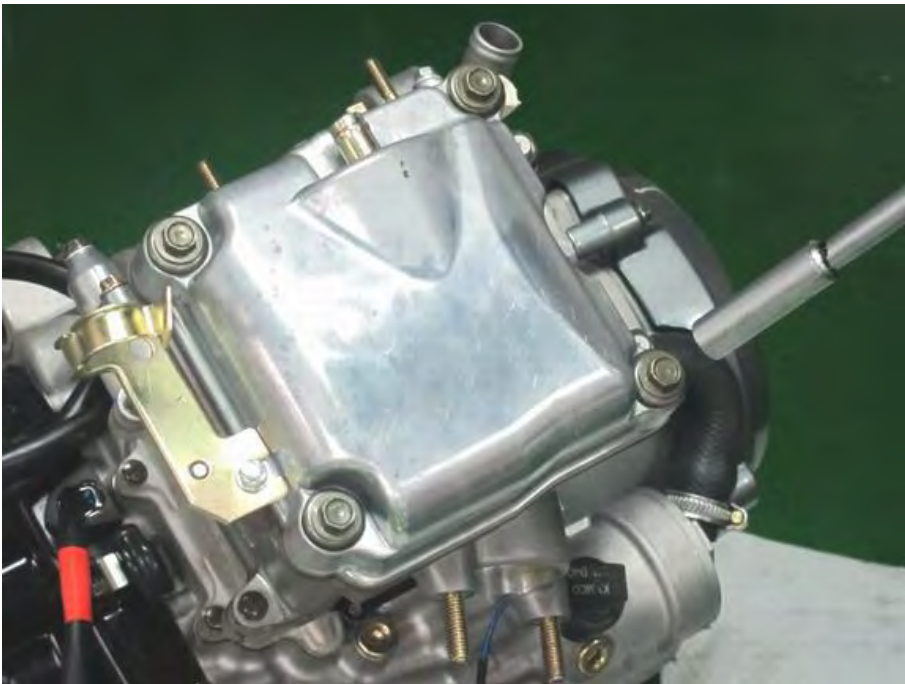

Tighten the cylinder head cover bolts securely in two steps and in a crisscross pattern with an 10 mm socket.

3. Engine > Cylinder Head Cover



Fit the fuel stay into place. Tighten the stay bolt securely with an 8 mm socket.



Install the breather hose to the cylinder head cover. Secure the hose with the clamp.



3. Engine > Camshaft

Camshaft

SAFETY FIRST: Protective gloves and eyewear are recommended at this point.

Removal



The crankshaft must be rotate (clockwise) until the piston is at top dead center (TDC) on the compression stroke.



Turn crankshaft clockwise until the "T" mark aligns with the index notch in the timing inspection hole.

3. Engine > Camshaft

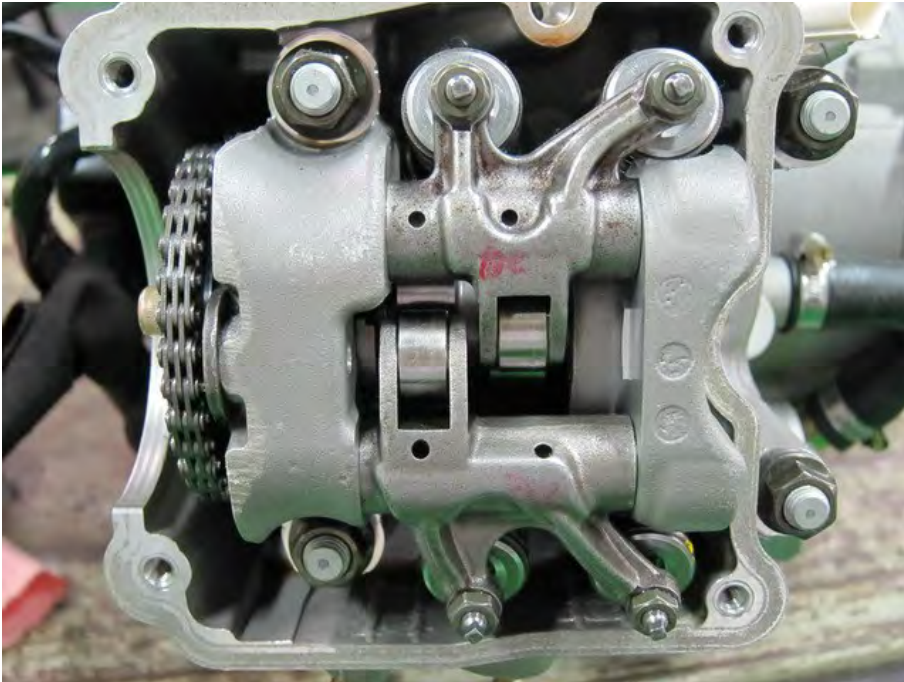

The piston should now be at TDC on the compression stroke. You can make sure that it is on the compression stroke by checking that there is some slack in the rocker arms. If the rocker arms are rigid, rotate the crankshaft 360° clockwise until the "T" mark is once again aligned with the notch on the case cover.



The cam chain tensioner is located on the back of the cylinder.

3. Engine > Camshaft



Remove the cam chain tensioner cap bolt with a 8 mm socket.



Loosen the cam chain tensioner mounting bolts evenly with an 8 mm socket.



Lift the cam chain tensioner out of the cylinder.
Remove the cam chain tensioner gasket.



Use a 5 mm Allen wrench to remove the camshaft sprocket bolts.



Remove the camshaft sprocket as shown. Support the chain so it does not fall into the cylinder head.

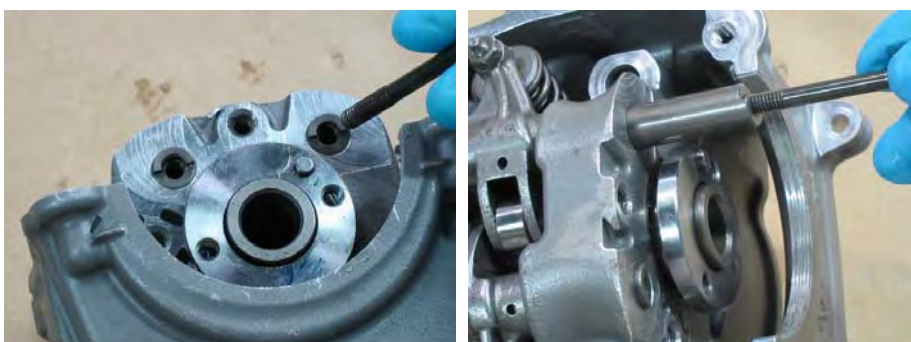

Thread a bolt into the rocker arm shafts and pull the shafts out.



Lift out the rocker arms as the shafts are removed.



Remove the camshaft from the cylinder head.

Inspection



Inspect the camshaft cam heights for the intake and exhaust lobes.

Inspect the camshaft bearings for excessive play or roughness. Replace the entire camshaft assembly if the bearings are rough or have excessive play.



Inspect the rocker arm shaft outer diameter for the intake and exhaust valves.

Item	Standard (mm)
Valve rocker arm shaft O.D.	9.972 - 9.987



Inspect the rocker arm bearings for excessive play or roughness.

Replace the entire rocker arm assembly if the bearings are rough or have excessive play.



Inspect the camshaft bearing journals for scoring or scratches.



Inspect the camshaft sprocket for worn teeth or other signs of wear or damage.

3. Engine > Camshaft

Camshaft Installation

Clear out the cylinder head oil passages with compressed air. Make sure all cylinder head oil passages are free of clogs.

NOTE: Always wear safety glasses when using compressed air and never point it directly at yourself or anyone else.



Position the piston at top dead center as above. The "T" mark should be aligned with the index notch in the timing inspection hole. Support the cam chain if the crank must be turned to position the piston correctly.

Lubricate the camshaft lobes and bearings with fresh engine oil.



Insert the camshaft into the camshaft holders with the lobes facing down.



Lubricate the inside diameter of the rocker arms and the roller with fresh engine oil. Position the rocker arms to accept the rocker arm shafts.

3. Engine > Camshaft

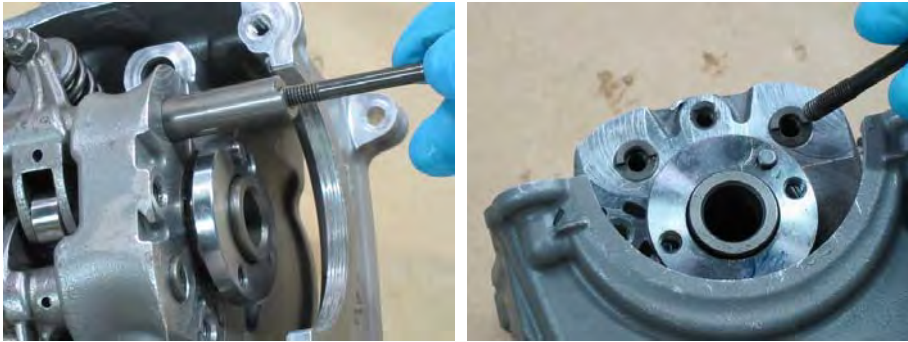

Wipe the rocker arm shafts clean. Insert the rocker arm shafts through the camshaft holders and rocker arms. Install the rocker arm shafts so that the end sits as shown.



Install the camshaft set plate so it fits into the groove on the camshaft and between the projections on the rocker arm shafts.

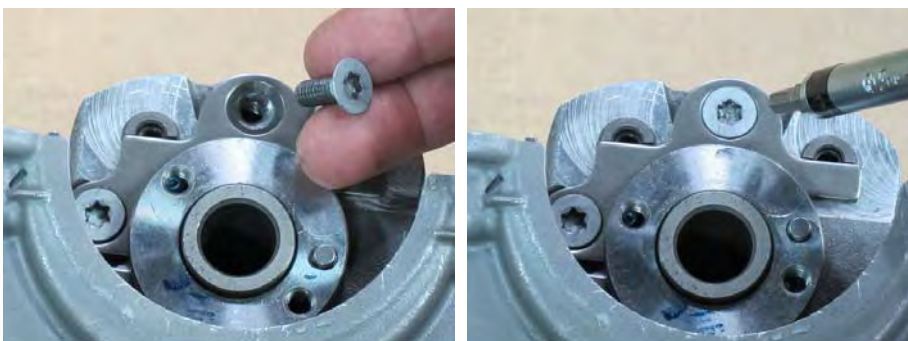

Apply a small amount of blue Loctite (non-permanent) to the threads of the set plate bolt. Thread in the bolt and tighten it to specification with a 5 mm Allen socket.

3. Engine > Camshaft

Item	Qty	Thread size (mm)	Torque	
			kgf-m	lb-ft
Camshaft set plate bolt	2	5	1.2	2.0



Install the camshaft sprocket onto the camshaft so the camshaft sprocket boss fits into the appropriate hole on the camshaft sprocket.

Make sure the camshaft sprocket boss is facing up so it is visible above the edge of the cylinder head as shown. Align the horizontal marks on the camshaft sprocket with the top edge of the cylinder head as shown. Fit the cam-chain over the camshaft sprocket.

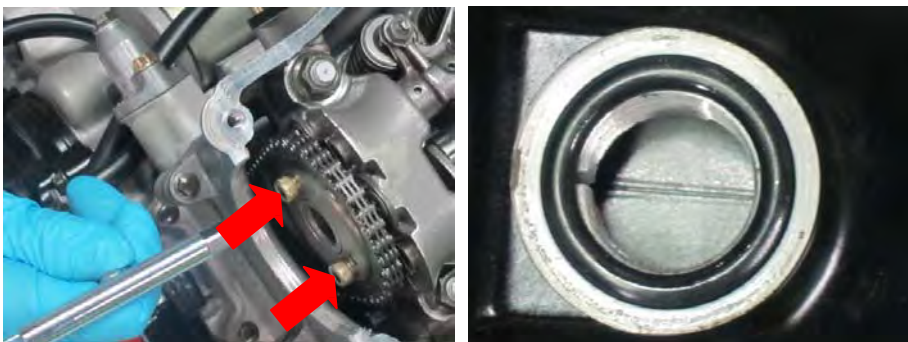

For correct engine timing the marks on the camshaft sprocket must be even with the cylinder head mating surface at the same time the "T" mark is lined up with the with the index notch in the timing inspection hole. The camshaft lobes should be facing down and their should be slack in the rocker arms.

3. Engine > Camshaft



Apply a small amount of blue Loctite (non-permanent) to the threads of the camshaft sprocket bolts. Thread in the camshaft sprocket bolts and tighten to specification using a 5 mm Allen socket.

Item	Qty	Thread size (mm)	Torque	
			kgf-m	lb-ft
Cam sprocket bolt	2	6	1.0-1.4	7.23-10.13



Install the cam-chain tensioner with a new gasket. Insert the mounting bolts and tighten them evenly to specification with an 8 mm socket. Remove the screwdriver and release the cam-chain tensioner rod.

Item	Qty	Thread size (mm)	Torque	
			kgf-m	lb-ft
Cam chain tensioner bolt	2	6	1.0-1.4	7.23-10.13



Rotate the crankshaft 360° clockwise and check the engine timing one more time.

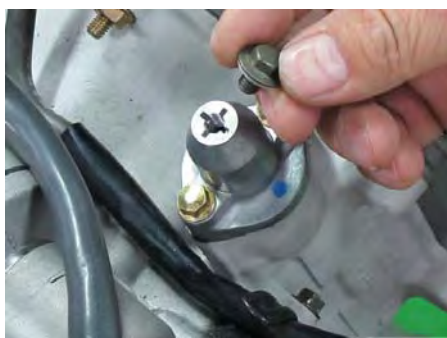

Make sure the cam chain tensioner cap bolt washer is in good condition. Install the washer and cam chain tensioner cap bolt. Tighten the bolt to securely with a 10 mm socket. Check the valve clearance.

3. Engine > Camshaft



Make sure the O-ring on the timing plugs are in good condition. Replace it as needed. Install the timing inspection cap to the right side of the engine. Tighten the cap securely but not overly with a large flat blade screwdriver.

3. Engine > Valves

Valves

SAFETY FIRST: Protective gloves and eyewear are recommended at this point.

Removal

IMPORTANT: Record the position of all parts so they can be returned to their proper place during reassembly.



Push down the valve springs with a valve spring compressor.

Special Tool- Valve Spring Compressor: A120E00063

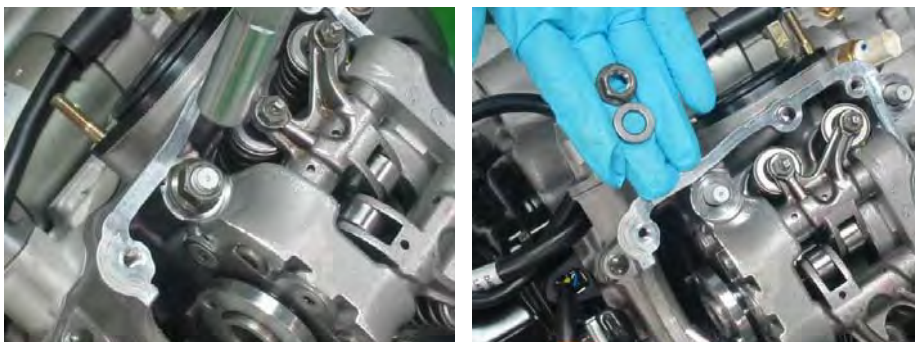

Remove the two nuts and washers on the top with a 14mm socket.

3. Engine > Valves

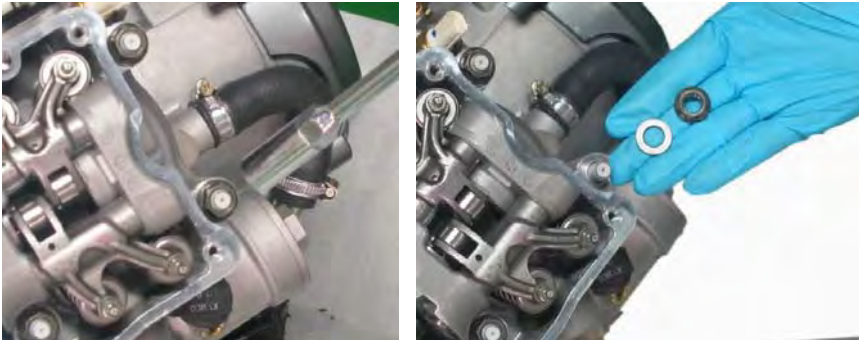

Remove the two nuts and washers on the left side with a 14mm socket.



Remove the two bolts on the right side with a 8mm socket.



Remove the nut on the inlet pipe side with a 10mm socket.

3. Engine > Valves



Remove the nut on the exhaust pipe side with a 10mm socket.

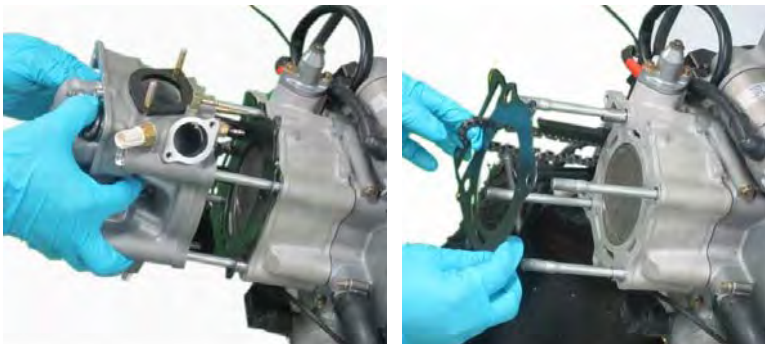

Remove the cylinder head assy and gasket.



Remove the split keepers. There are two per valve.

3. Engine > Valves



Remove the spring retainer.



Remove the valve springs.

3. Engine > Valves



Push the valve stem down and remove the valve from the combustion chamber side of the cylinder head. Rotate the valve as it is removed.



Remove the valve seal from the valve guide. The valve seals should be replaced if they are removed or you are going to install new valves.

3. Engine > Valves



Remove the spring seat.

Inspection



Inspect the valve springs for fatigue and damage. Replace the valve springs as needed or if the valve is also to be replaced.

3. Engine > Valves



Inspect the valves for damage and burning. Measure the valve stem diameter in several places where the valve makes contact with the guide. If the measurement is below specification replace the valve.

Item		Standard (mm)
Valvestem O.D.	IN	4.75-4.99
	EX	4.55-4.97

3. Engine > Valves



Inspect the valve seat and the valve seat width. The valve seat should be centered on the valve face. If the seat is pitted, worn out, or fits poorly on the valve face the valve seat must be resurfaced.

Item		Standard (mm)
Valve seat width	IN	1.7±0.1
	EX	1.7±0.1



Measure the inside diameter of the valve guides. Replace the guides if the measurement is out of specification. Calculate the valve stem-to-guide clearance. Replace the guide and valve if the clearance is out of specification

3. Engine > Valves

Item		Standard (mm)
Valve guide I.D	IN	5.00-5.012
	EX	9.990-10.015
Valve stem-to-guide clearance	IN	0.010-0.037
	EX	0.030-0.057

Installation

Clean the cylinder head components thoroughly with a high flash-point solvent and compressed air. Return the components to their original locations.

NOTE: Always wear safety glasses when using compressed air and never point it directly at yourself or anyone else.



Install the spring seat.



Coat the new valve seal in fresh engine oil and install it onto the valve guide.

3. Engine > Valves



Coat the valve stem in fresh engine oil and insert the valve into the valve guide and through the seal. Turn the valve slowly as it is inserted. If you are installing a new valve you must ream the valve guide first. Make sure the valve will move smoothly in the valve guide without wobble.

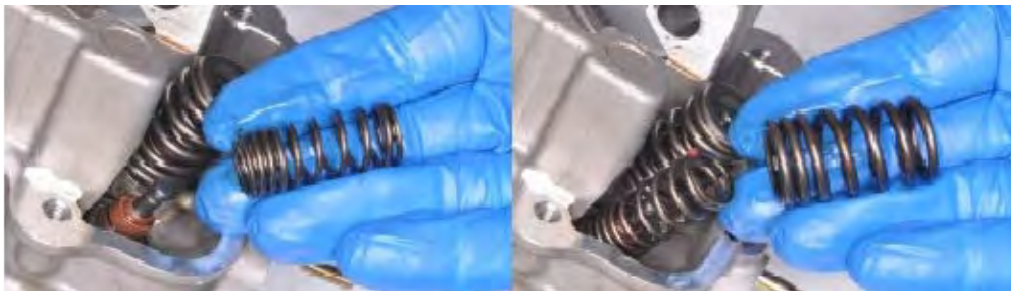

Install the valve springs. The tightly coiled end of the springs should sit against the spring seat.

3. Engine > Valves



Place the spring retainer on top of the spring.



Push down the valve springs with a valve spring compressor to allow enough room to install the split keepers. The valve cotter installer tool can also be used to install the split keepers.

Special Tool- Valve Spring Compressor: A120E00063

3. Engine > Valves



Apply grease to the inside of the split keepers. Apply a dab of grease to the end of a flat blade screwdriver. Set the keeper in the grease on the screwdriver and insert it onto the valve stem. Repeat this with the other keeper.

After the valves have been reassemble place a clean shop towel under the cylinder head in the combustion chamber area and gently tap each valve stem with a plastic rod and rubber mallet to make sure the valves are seated properly.

3. Engine > Cylinders and Pistons

Cylinders and Pistons

SAFETY FIRST: Protective gloves and eyewear are recommended at this point.

Cylinder Block Removal



Slide out the lower cam chain guide. Inspect the guide for excessive wear and damage. Replace the guide as needed.

Remove two towel pins



Remove the two cylinder bolts on the right side of the engine.

3. Engine > Cylinders and Pistons



Slide the cylinder off of the studs and piston. Guide the cam chain through its opening and do not allow it to fall into the crankcase. Remove the cylinder.



Remove the base gasket.

3. Engine > Cylinders and Pistons



Remove the two cylinder dowel pins from the left studs.
Place a clean shop towel under and around the base of the piston to prevent any parts or debris falling into the crankcase.



Remove the piston pin clips with a pick or needle nose pliers. Discard the piston pin clips.

3. Engine > Cylinders and Pistons

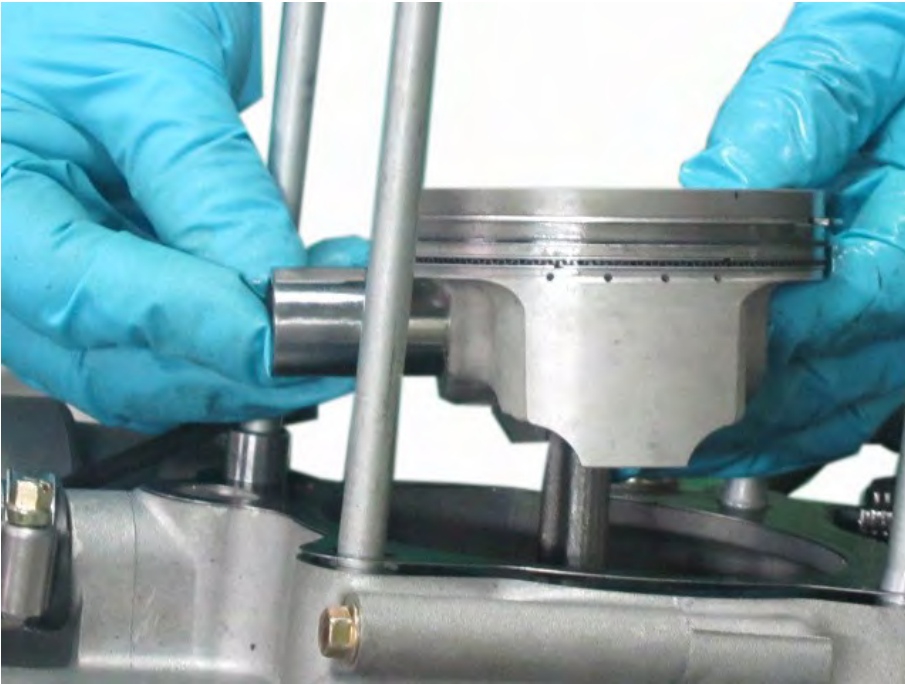

Remove the piston pin and the piston.

Clean off the cylinder mating surface, but take care to keep debris from falling into the crankcase.



Spread the piston rings and lift them off opposite the gap. Spread the rings the minimum amount during removal. The rings can be easily damaged.

3. Engine > Cylinders and Pistons

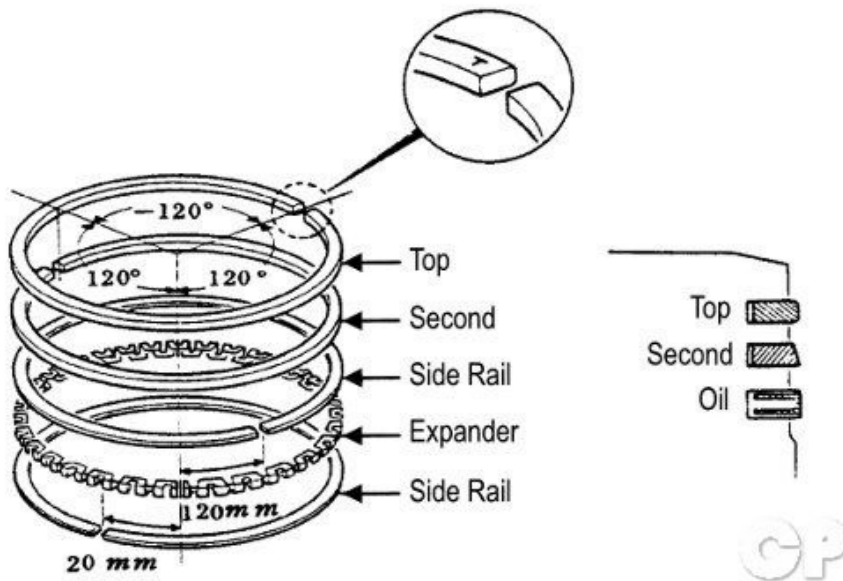

The two upper rings are each a single piece of metal. The oil ring consists of an expander ring and two side rails.



Clean the carbon build up off of the piston with a stiff bristled plastic brush or rag. Never use a wire brush to clean a piston.

3. Engine > Cylinders and Pistons

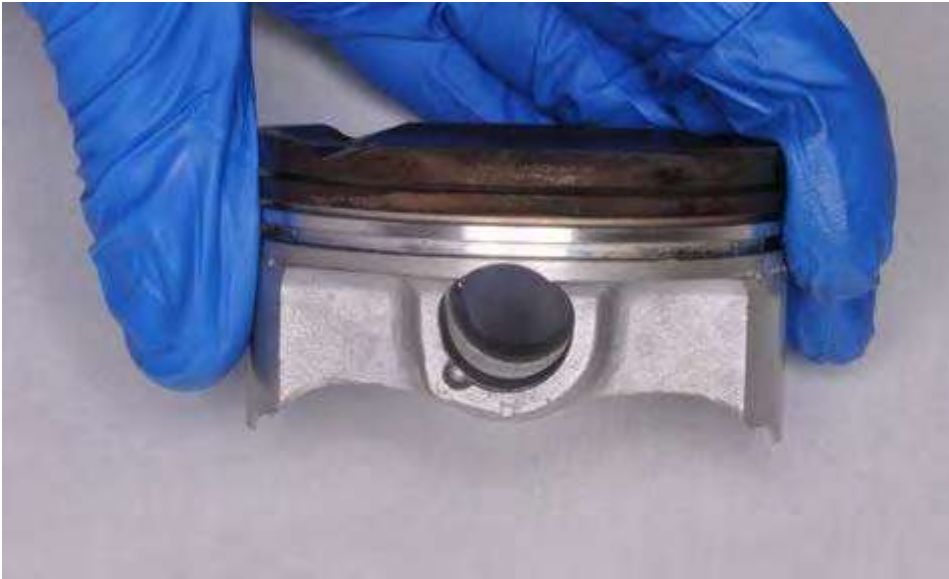

Also clean out the ring grooves. You can use an old ring to scrape out any carbon build up in the grooves.

Inspection

The cylinder and piston must be replaced as a set. There are two sets of cylinder and piston combinations. Make sure to have a No.1 cylinder with an "A" piston or a No.2 cylinder with a "B" piston.

Mark	Piston O.D. (mm)	Mark	Cylinder I.D. (mm)
A	83.99 – 83.98	A	84.00 – 84.01
B	84 – 84.01	B	84.01 – 84.02

3. Engine > Cylinders and Pistons

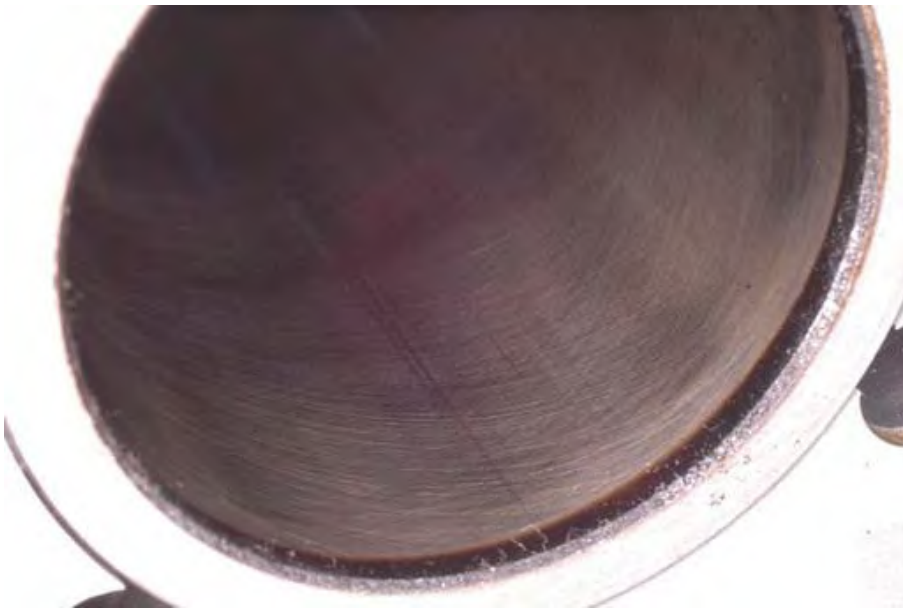

Inspect the cylinder bore for damage and abnormal wear



Measure the cylinder diameter as described below with a telescoping gauge.

3. Engine > Cylinders and Pistons

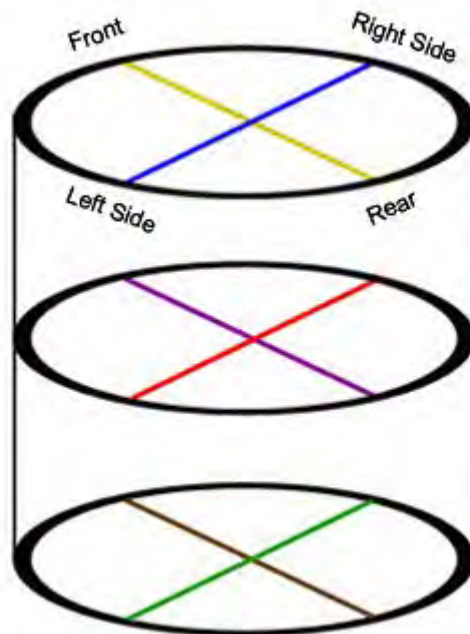

Inspect the cylinder front to back and side to side at three different height levels with a dial bore gauge.

No.	Mark	Cylinder I.D. (mm)
1	A	84.00 – 84.01
2	B	84.01 – 84.02

Calculate the cylinder taper. The taper is the maximum difference between either yellow and brown or blue and green.

Item		Limit (mm)
Cylinder	Taper	0.05

Calculate the cylinder out of round. The out of round is greatest out of yellow, purple, or brown minus the smallest of blue, red, or green.

Item		Limit (mm)
Cylinder	Out of round	0.05



Measure the outside diameter of the piston at 9 mm up from the bottom of the skirt at a 90° angle to the piston pin. Measure the piston with vernier calipers or a micrometer. Check the piston for wear, damage, and extreme discoloration.

Subtract the diameter of the piston from the maximum front to rear diameter measurement of the cylinder to calculate the piston-to-cylinder clearance. Replace the piston and cylinder as needed to achieve a correct piston-to-cylinder clearance.

Item	Standard (mm)
Piston-to-cylinder clearance	0.010 - 0.030



Measure the piston pin diameter with a micrometer. Measure the piston pin bore diameter with vernier calipers or a small bore gauge. Measuring at three different points for each. Replace the parts if any of the specifications are not met.

Item	Standard (mm)
Piston pin hole I.D.	20.002 - 20.008
Piston pin O.D.	19.994 - 20.000
Piston-to-piston pin clearance	0.002 - 0.014

3. Engine > Cylinders and Pistons



Measure the inside diameter of the small end of the connecting rod with vernier calipers.

Item	Standard (mm)
Connecting rod small end I.D. Bore	20



Measure the ring groove width and the ring-to-groove clearance with feeler gauges.

Item		Standard mm
Piston ring-to-groove clearance	1st	0.015 - 0.055
	2nd	0.015 - 0.055

3. Engine > Cylinders and Pistons



Insert the top ring into the cylinder. Push the top ring in the cylinder about an inch. Use the piston to push in the ring to keep it square with the cylinder.



Measure the ring gap with a feeler gauge. Repeat this procedure with second ring and the oil side rails.

Item		Standard mm
Ring end gap	Top	0.10-0.25
	Second	0.10-0.25
	Oil side rail	0.2-0.7

3. Engine > Cylinders and Pistons



Check the oil jet for clogs.

Assembly



Clean the piston ring grooves and apply fresh engine oil to the piston rings. Spread the rings the minimum amount possible to install them. Do not try and force them on the piston.

3. Engine > Cylinders and Pistons

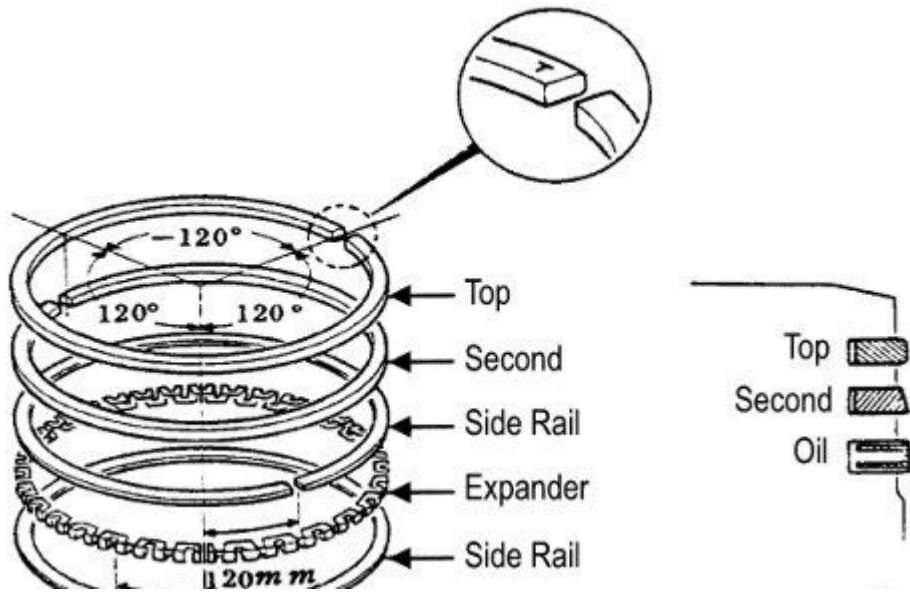

Install the top and second rings with their markings facing up. Install the rings to the piston as shown above so that no ring end gaps line up with the piston pin or perpendicular to the piston pin. The rings should turn easily on the piston without sticking or roughness.

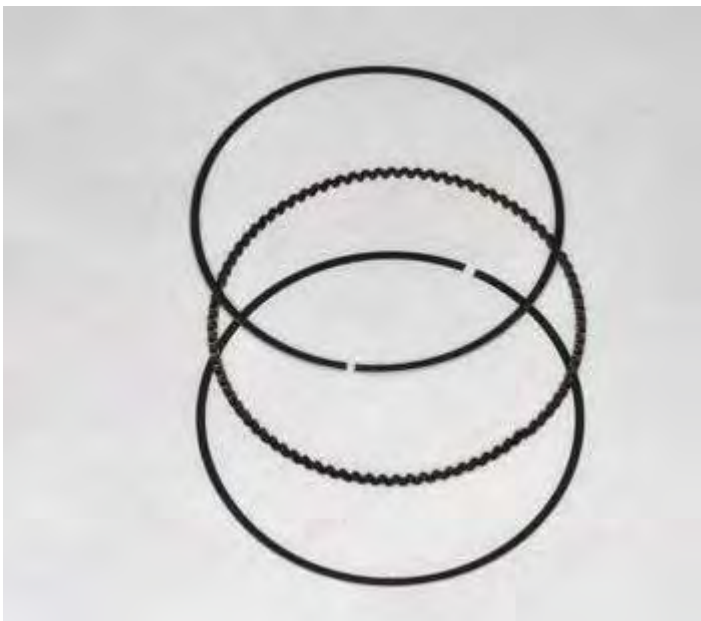

Install the oil expander ring so that the ends are not overlapping. Install the steel rails above and below the oil ring.

Lubricate the piston pin and the small end of the connecting rod with fresh engine oil.

3. Engine > Cylinders and Pistons



The "IN" mark should face the intake side (rear) of the engine.

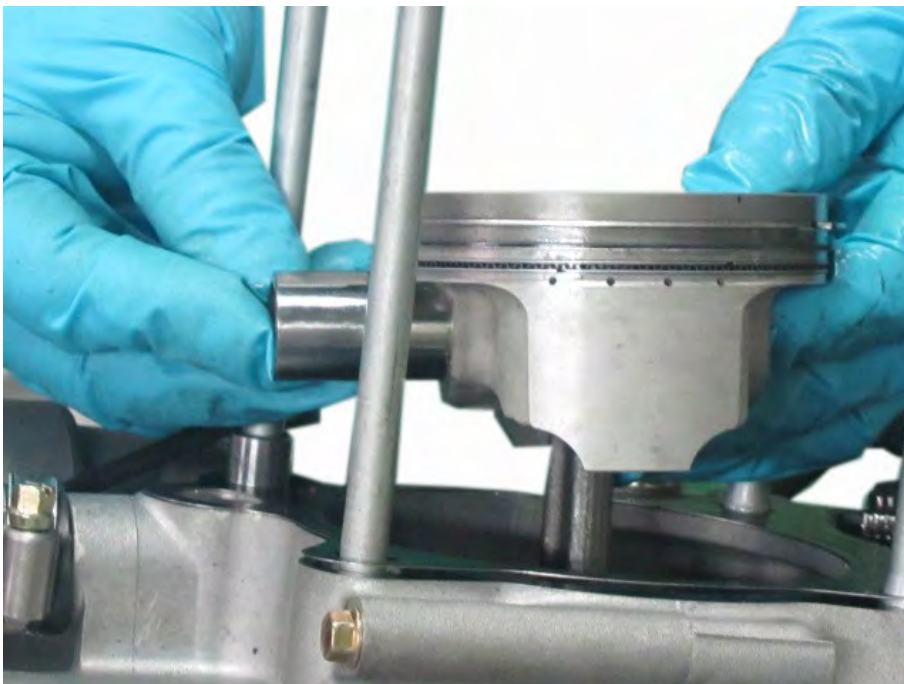

Place the piston over the connecting rod. Insert the piston pin into the piston and rod.

3. Engine > Cylinders and Pistons



Install new piston pin clips securely into their grooves. Turn the gap in the clips away from the access gap.



Make sure the cylinder head mating surface is clean. Install the two dowel pins as shown.

3. Engine > Cylinders and Pistons



Install the new base gasket onto the crankcase.



Coat the inside of the cylinder, piston rings, and piston in fresh engine oil. Lower the cylinder over the studs and guide the piston into the cylinder while you are compressing the rings with your fingers. Be careful to not damage the rings during this step. Bring the cam chain and guide through the opening.

3. Engine > Cylinders and Pistons



Thread in the two cylinder bolts on the right side of the engine.



Insert the lower cam chain guide and make sure it is seated correctly.

A.C. Generator and Starter clutch

SAFETY FIRST: Protective gloves and eyewear are recommended at this point.

Removal

Generator Cover

Remove the following components -

- # Seat
- # Luggage Box
- # Center Cover
- # Rear Carrier
- # Body Cover
- # Front Cover
- # Front Lower Cover
- # Foot Skirt



Disconnect the generator 3-pin connector.



Disconnect the crank position sensor wire coupler.

3. Engine > Generator



Loosen the water pump hose clamp with a #2 Phillips screwdriver. Slide up the clamp and free the coolant hose from the water pump. Allow any remaining coolant to drain into a suitable container.



Loosen the right crankcase coolant hose clamp with a 8mm socket. Slide up the clamp and free the coolant hose from the right crankcase cover. Allow any remaining coolant to drain into a suitable container.



3. Engine > Generator



Remove the 12 generator cover bolts with an 8 mm socket.
Note the upper bolt holds a wire stay.



Remove the generator cover.



Remove the generator cover gasket.



Remove the two dowel pins.



Remove the oil release valve. Inspect the O-ring and replace it as needed.

Stator and Pulsar Coil/Crank Position Sensor



Free the rubber wire grommet from the right crankcase cover.

3. Engine > Generator



XCITING 400i



XCITING S 400

Remove the three stator mounting bolts and the two crank position sensor bolts with an 8 mm socket. Remove the stator and the crank position sensor together.

Flywheel



To remove the fly wheel two special tools are needed.

ITEM	TOOL NO.
UNIVERSAL HOLDER	A120E00021



ITEM	TOOL NO.
FLYWHEEL PULLER	A120E00097



Hold the flywheel with the universal holder and loosen the nut with a 19 mm socket.

3. Engine > Generator



Remove the flywheel nut and washer.



Apply a protect stay to the threads of the crankshaft before using it. Hold the tool with a large wrench and turn in the bolt until the pressure separates the flywheel from the crankshaft.



Remove the flywheel from the crankshaft.



Slide the starter driven gear off of the crankshaft.



Remove the woodruff key from the crankshaft.

Starter Clutch



Remove the starter idle gear and shaft from the crankcase.

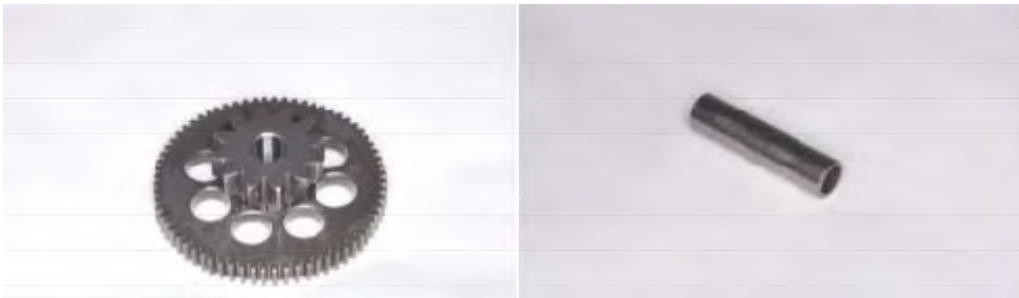

Inspect the starter idle gear and shaft for wear and damage. Replace the idle gear and shaft as needed.



Inspect the starter driven gear for wear and damage. Measure the inside and outside diameter of the starter driven gear and replace it as needed.

Item	Standard (mm)
Starter drive gear I.D.	25.026 – 25.045
Starter clutch boss O.D.	45.660 – 45.673

3. Engine > Generator



Fit the boss of the starter driven gear into the starter clutch. The starter clutch should only allow the driven gear to turn in one direction. If the starter clutch allows turning both ways or will not let the driven gear rotate smoothly in one direction the starter clutch must be replaced.



Remove the three starter clutch mounting bolts with a 6 mm Allen socket.

Installation

Starter Clutch



Fit the starter clutch to the back of the flywheel. Apply blue Loctite to the threads of the three starter clutch mounting bolts. Insert the three starter clutch mounting bolts.

3. Engine > Generator



Tighten the starter clutch mounting bolts to specification with a 6 mm Allen socket.

Item	Qty	Thread size (mm)	Torque	
			kgf-m	lb-ft
Oneway clutch bolt	3	8	0.8 -1.2	5.76 – 8.64



Lubricate the starter idle gear shaft with fresh engine oil. Install the starter idle gear and shaft into the crankcase.

Flywheel



Install the woodruff key into its slot on the end of the crankshaft.



Lubricate the inside of the starter driven gear with fresh engine oil. Slide the starter driven gear onto the flywheel as shown.

Clean off the tapered end of the crankshaft where the flywheel will ride and make sure the inside of the flywheel is oil free where it will contact the crankshaft.



Line up the groove in the flywheel with the key and fit the flywheel onto the crankshaft. Guide the starter driven gear into the starter clutch on the back of the flywheel.



Install the washer and flywheel nut.



Hold the flywheel with the universal holder and torque the flywheel nut to specification with a 19 mm socket.

Item	Qty	Thread size (mm)	Torque	
			kgf-m	lb-ft
ACG flywheel nut	1	14	5.5-6.5	39.78-47.01

ITEM	TOOL NO.
UNIVERSAL HOLDER	A120E00097

3. Engine > Generator

Stator and Crank Position Sensor

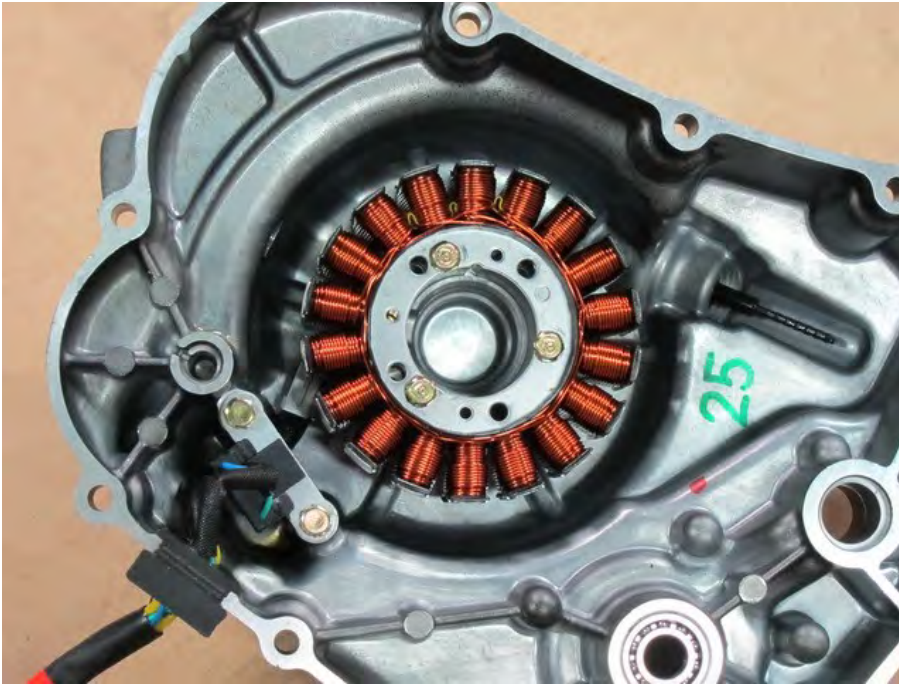

Fit the stator and the crankshaft position sensor into the generator cover together as shown. Insert the two crank position sensor mounting bolts and the three stator mounting bolts. Tighten the bolts securely with an 8 mm socket.



Coat the rubber grommet in silicone sealant where it contacts the generator cover. Fit the rubber wire grommet into its cutout in the crankcase cover.

Generator Cover



Make sure the generator cover mating surface is clean.
Install the two dowel pins and a new generator cover gasket.



Install a new gasket.

3. Engine > Generator



Make sure the oil release valve is in place and in good condition.



Fit the generator cover into place. Make sure the water pump shaft engages correctly with the oil pump shaft.

3. Engine > Generator



Insert the 12 generator cover bolts. Note the upper bolt holds a wire stay. Tighten the bolts securely in a with an 8 mm socket.



Fit the coolant hose to the right crankcase cover pipe. Secure the hose with the clamp and tighten the coolant hose clamp securely with a #2 Phillips screwdriver.

3. Engine > Generator



Connect the coolant hose to the water pump. Move the clamp into place and tighten it securely with a #2 Phillips screwdriver.



Plug in the regulator/rectifier 3-pin connector.



Plug in the crank position sensor wire coupler on the right side of the frame.

Oil Pump

SAFETY FIRST: Protective gloves and eyewear are recommended at this point.

GENERAL INSTRUCTIONS

The maintenance of lubrication system can be performed with the engine installed in the frame. Use care when removing and installing the oil pump not to allow dust and foreign matters to enter the engine and oil line.

Do not attempt to disassemble the oil pump. The oil pump must be replaced as a set when it reaches its service limit.

After the oil pump is installed, check each part for oil leaks.

TROUBLESHOOTING

Oil level too low

1. Natural oil consumption
2. Oil leaks
3. Worn or poorly installed piston rings
4. Worn valve guide or seal

Poor lubrication pressure

1. Oil level too low
2. Clogged filter or oil passages
3. Not using the specified oil

3. Engine>Oil Pump

Oil Pump Removal



The oil pump is driven by a chain off of the crankshaft.



Loosen the two oil pump cover bolts with an 8 mm socket.

3. Engine>Oil Pump



Remove the two oil pump cover bolts and the oil pump cover.

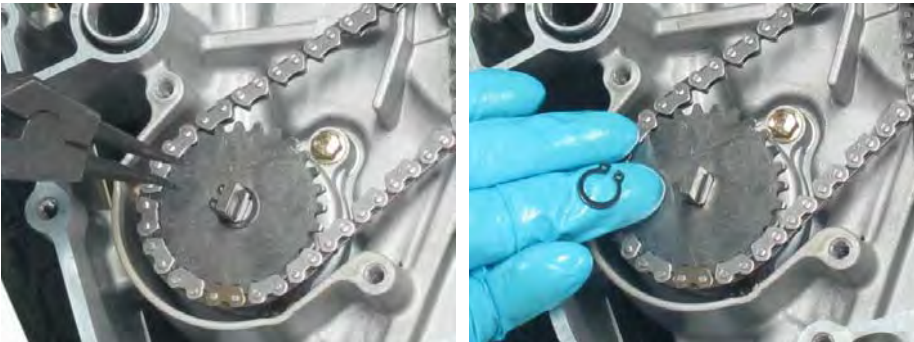

Remove the snap ring on the oil pump shaft with snap ring pliers.



Remove the oil pump drive chain and driven sprocket.

3. Engine>Oil Pump



Inspect the oil pump drive chain and sprocket for signs of wear and damage. Replace the parts as needed.



Remove the three oil pump screws with an 8mm socket.



Remove the oil pump.

3. Engine>Oil Pump



Turn the oil pump shaft by hand and make sure it turns smoothly. If the oil pump shaft will not rotate smoothly the oil pump should be replaced with a new unit.

Oil Pump Installation



Fit the oil pump into place so that the arrow is pointing up.

3. Engine>Oil Pump



Insert the three oil pump mounting screws and tighten them securely with an 8mm socket.



Fit the oil pump driven sprocket into the drive chain. Install the gear onto the oil pump shaft and fit the chain onto its teeth on the crankshaft.



Install a new snap ring into its groove with snap ring pliers.

3. Engine>Oil Pump



Install the oil pump cover and its two mounting bolts.



Tighten the two oil pump cover bolts securely with an 8 mm socket.

Crankcase

SAFETY FIRST: Protective gloves and eyewear are recommended at this point.

Splitting



Remove the upper cam chain guide bolt with an 8 mm Allen.



Remove the upper cam chain guide.

3. Engine > Crankcase



Inspect the cam chain guides for damage and excessive wear. Replace the guides as needed.



Remove the cam chain from the crankshaft and crankcase. Inspect the cam chain for wear and damage. Replace the cam chain as needed.

3. Engine > Crankcase



Remove the six bolts mounting the left crankcase cover protector.

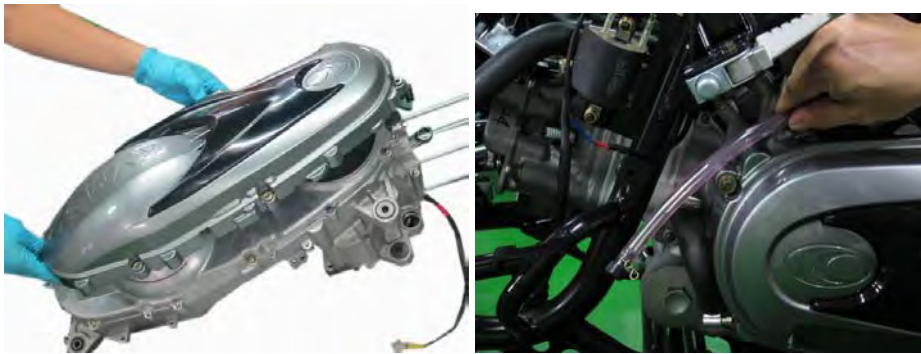

XCITING 400i

XCITING S 400

Remove the left crankcase cover protector.



3. Engine > Crankcase

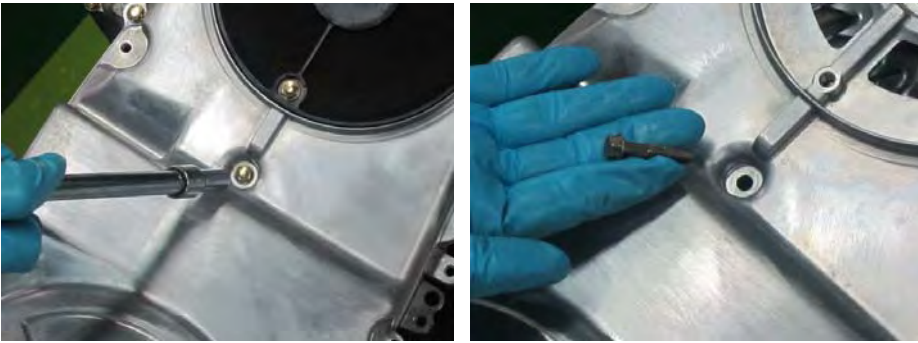

Remove the nine bolts mounting the left crankcase cover.

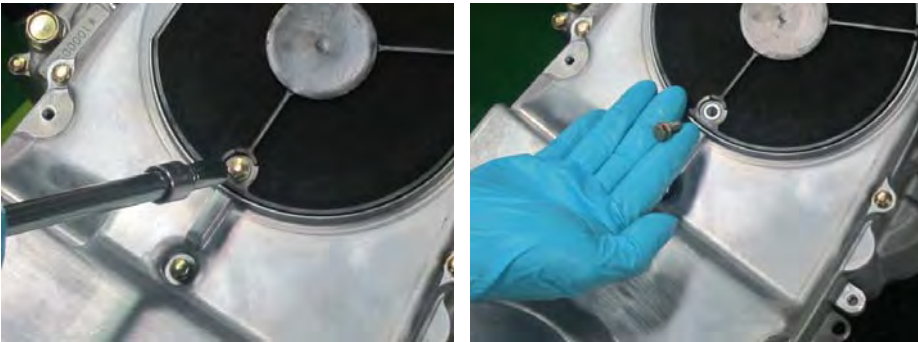

Remove the two bolts mounting the element duct left crankcase cover.

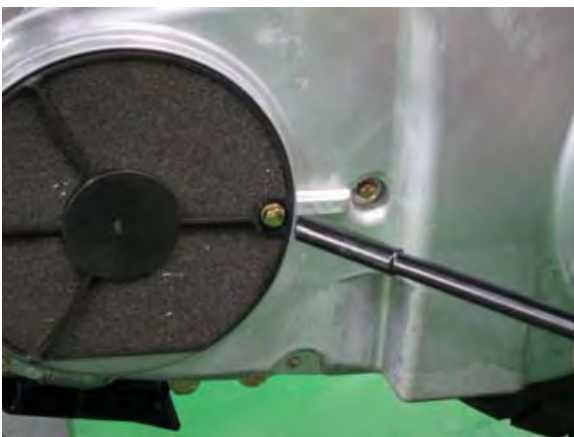

XCITING 400i



XCITING S 400

Remove the element duct.

3. Engine > Crankcase



Remove the #M14 nut mounting the clutch outer.



Remove the #M18 nut mounting the drive face.



Remove the left crankcase cover.



XCITING 400i



XCITING S 400

3. Engine > Crankcase



There are 12 crankcase bolts.



Loosen the 12 crankcase bolts in a crisscross pattern with an 8 mm socket. Remove the crankcase bolts from the left side of the engine.



Remove the plate with the bottom two crankcase bolts.

3. Engine > Crankcase



Set the crankcases on the right side.



Separate the halves of the crankcase. If needed gently tap the reinforced areas of the right crankcase half with a rubber mallet. Lift the right crankcase off of the left.

3. Engine > Crankcase



Remove the two dowel pins from the crankcase. Inspect the O-ring and replace it as needed.

3. Engine > Crankcase



Replace the left crankshaft seal if the crankcases are separated.



Remove the seal with a seal pick.

3. Engine > Crankcase



Drive the new seal into the left crankcase from the outside with a suitable driver. The driver should have the same outside diameter as the seal. Lubricate the new crankshaft seal lips with fresh engine oil.

Assembly

Thoroughly clean the crankcase mating surface.



Apply sealant uniformly to the crankcase mating surface as indicated. Do not allow sealant to enter oil passages or get in bearings.

3. Engine > Crankcase



Set the right case half down on top of the left. Install the engine mount spacer.



Insert the 12 crankcase bolts.
The plate goes on with the bottom two bolts.

3. Engine > Crankcase



Tighten the bolts securely and evenly in a crisscross pattern with an 8mm socket.



Install the cam chain around the timing sprocket teeth on the crankshaft.

3. Engine > Crankcase



Fit the upper cam chain guide into place.

Insert the upper cam chain guide mounting bolt and tighten it to specification with an 8 mm Allen socket.

Item	Qty	Thread Size(mm)	Torque	
			kgf-m	lb-ft
Cam chain tensioner pivot	1	8	0.8-1.2	5.79-8.68

Crankshaft

SAFETY FIRST: Protective gloves and eyewear are recommended at this point.

Removal



Lift the crankshaft out of the left crankcase half.

3. Engine > Crankshaft

Crankshaft Inspection

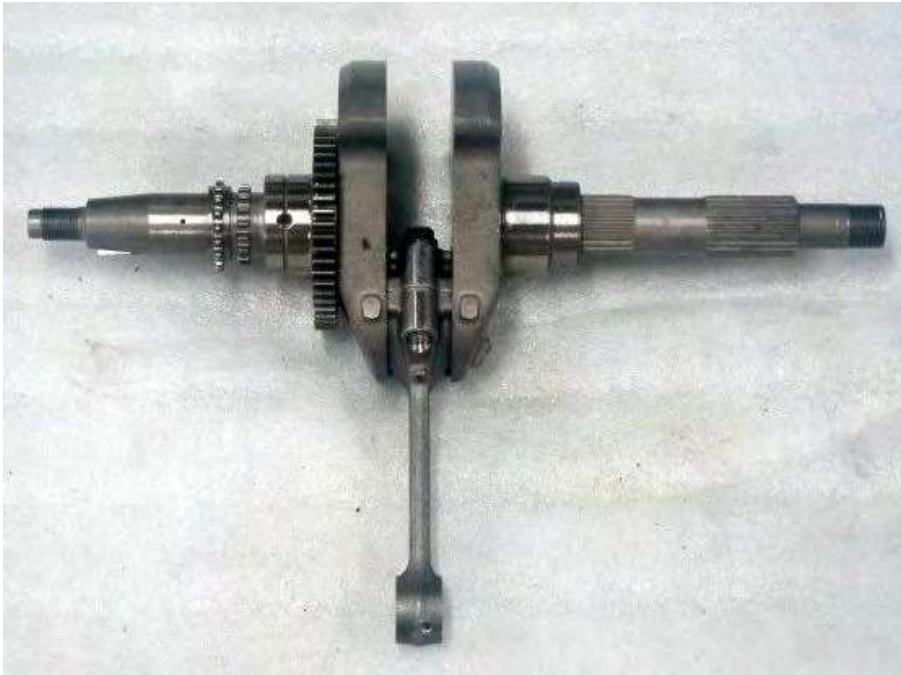

Check the side clearance of the big end of the connecting rod with a feeler gauge.

	Item	Standard (mm)	Service Limit (mm)
Crankshaft	Connecting rod big end side clearance	0.15-0.35	0.6

3. Engine > Crankshaft

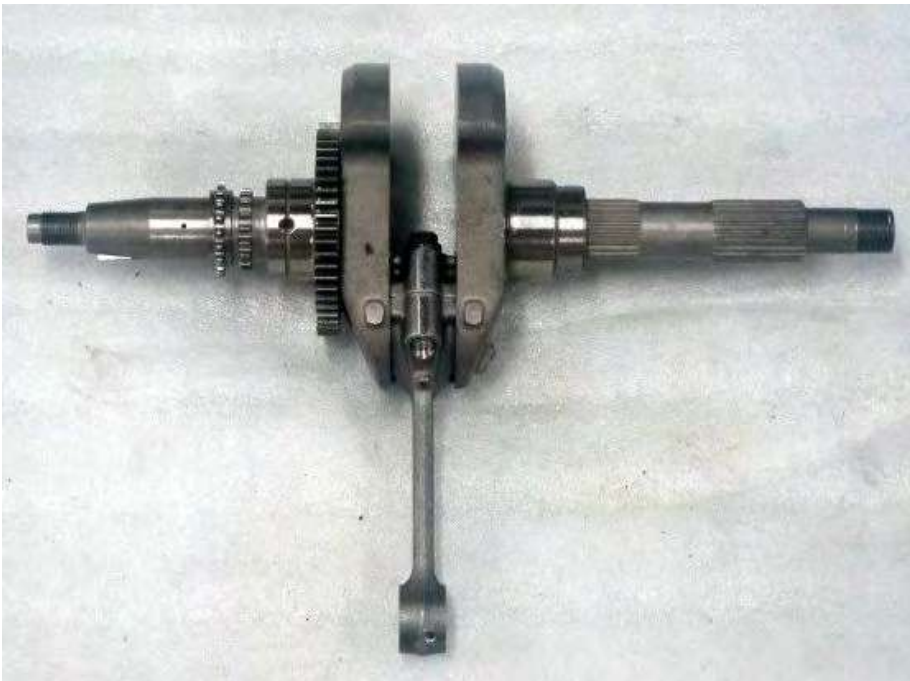

Grip the small end of the connecting rod and try and push the rod down towards the crank weights. If there is definite play between the connecting rod and crank the crankshaft should be replaced.

Crankshaft Bearings



Inspect the crankshaft bearings for signs of damage and wear. Replace the bearings if they show any kind of imperfection.

3. Engine > Crankshaft

Note the bearing color code and crankcase code.

The crank weights are also marked with a size code.

When the crankshaft and or crankcases must be replaced also replace both crank bearings according to the chart below.

Crankshaft \ Bearing	Crankcase	
	Crankcase mark	
Crankshaft mark	A	B
A	BLACK	GREEN
B	GREEN	RED

Installation

Lubricate the connecting rod big end and crankshaft shaft bearings with fresh engine oil.



Fit the crankshaft into the left crankcase bearing. Take care to avoid damaging the new oil seal.

Engine Installation

SAFETY FIRST: Protective gloves and eyewear are recommended at this point.



Set the chassis on its center stand. Use a jack to support the engine. Guide the engine into the back of the frame.



3. Engine > Engine Installation



Fit the engine mounting bracket and damper assembly into place.



Install the two engine mounting bracket to frame mounting bolts and nuts. Insert the bolts from the outside of the frame.

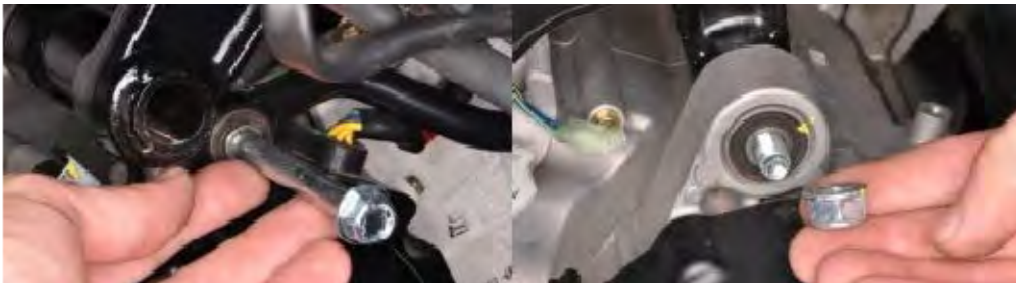

Insert the engine mounting bracket and damper bolt from the right side. Thread on the nut.



Install the engine mounting bracket damper washer and nut.



Hold the engine mounting bolts with a 14 mm wrench and torque the nuts to specification with a 19 mm socket.

Item	Qty	Thread size (mm)	Torque		Remarks
			kgf-m	lb-ft	
Engine hanger: Frame side	2	14	6.0-7.0	43.40-50.63	U-nut

3. Engine > Engine Installation



Tighten the engine mounting bracket damper bolt and nut with a 17 mm wrench for the nut and a 14 mm socket for the bolt.

Item	Qty	Thread size(mm)	Torque		Remarks
			kgf-m	lb-ft	
Engine hanger: Engine side	1	10	4.5-5.5	32.55-39.78	U-nut



Tighten the damper nut securely with a 14 mm socket.

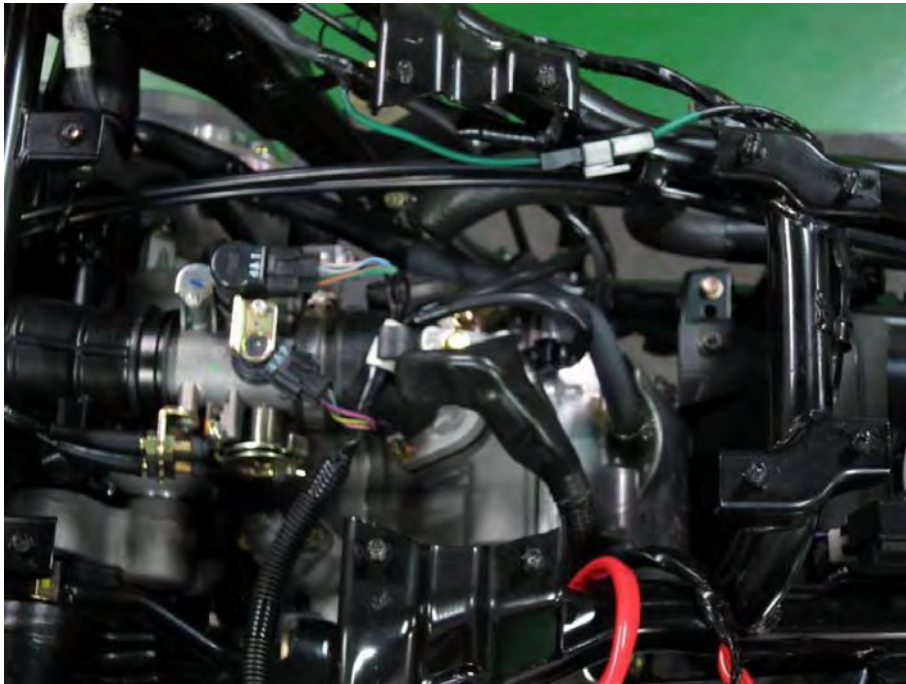

Route the wiring harness through its guide above the intake pipe.



Plug in the oil pressure switch bullet connector.



Route the starter motor lead to the starter motor and secure it in the stay on the right crankcase cover.



Fit the starter motor cable lead onto the terminal and thread on the nut. Tighten the starter motor lead nut securely with a 10 mm wrench.



Fit the rubber starter motor lead cover into place.

3. Engine > Engine Installation



Install the main engine ground to the right side of the engine. Tighten the main engine ground bolt securely with an 8 mm socket.



Install air bleed hose and secure it with the clamp.



Connect the coolant hose to the thermostat. Move the clamp into place and tighten it securely with a #2 Phillips screwdriver.

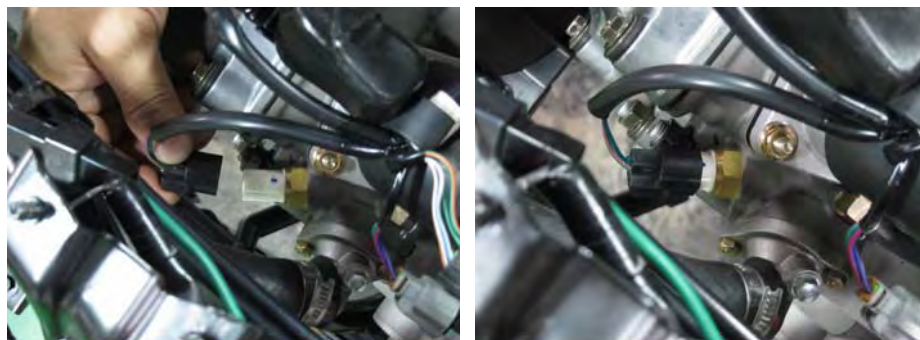

Plug in the water temperature sensor connector.

3. Quick Reference > Specifications



Connect the coolant hose to the water pump. Move the clamp into place and tighten it securely with a #2 Phillips screwdriver.



Fit the fuel stay into place. Tighten the stay bolt securely with an 8 mm socket.

5. Cooling System

This chapter covers the location and servicing of the cooling system components for the KYMCO XCITING S 400 model.

General Instructions	5-1
Troubleshooting	5-2
Coolant	5-3
Radiator	5-11
Water Temperature Sensor (WTS)	5-16

GENERAL INSTRUCTIONS

- The water pump must be serviced after removing the engine. Other cooling system service can be done with the engine installed in the frame.
- The engine must be cool before servicing the cooling system. When the coolant temperature is over 100°C, never remove the radiator cap to release the pressure because the boiling coolant may cause danger.
- Avoid spilling coolant on painted surfaces because the coolant will corrode the painted surfaces. Wash off any spilled coolant with fresh water as soon as possible.
- After servicing the system, check for leaks with a cooling system tester.

TROUBLESHOOTING

Engine temperature too high

- Faulty temperature gauge or sensor
- Faulty radiator cap
- Faulty thermostat
- Insufficient coolant
- Passages blocked in hoses or water jacket
- Clogged radiator fins
- Passages blocked in radiator
- Faulty water pump

Temperature gauge shows the wrong temperature

- Faulty temperature gauge or sensor
- Faulty thermostat

Coolant leaks

- Faulty pump mechanical (water) seal
- Deteriorated O-rings
- Damaged or deteriorated water hoses

Coolant

For the sake of safety, check level of cooling water before riding the vehicle. Replace the cooling liquid as specified in Regular Maintenance Schedule.

Check Level of Cooling Water

1. Park the vehicle on level ground and brace it up with Main Stand.
2. Figure to be inserted

NOTICE

- ◆ Temperature in the engine may cause false reading of Cooling Water level. Check water level after the engine cools down.
- ◆ Inclined vehicle may cause false reading of Cooling Water level.

3. Check level of Cooling Water via viewing window on the water preserving tank. Make sure the level is between “F” and “L” marks.

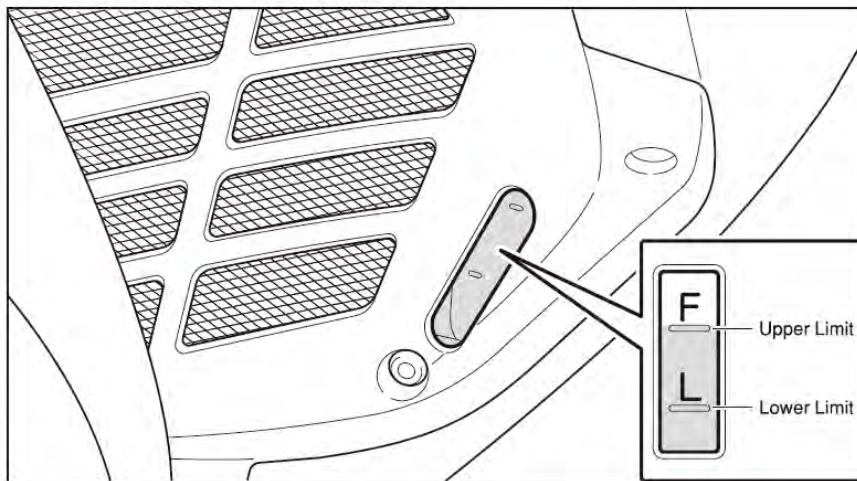

NOTICE

- ◆ Before riding the vehicle, check the water tank and piping or any leakage.
- ◆ Check the ground where the vehicle is parked for any leakage mark.
- ◆ Before riding the vehicle, check the fin and front protection screen of water tank for any foreign object. Foreign objects may reduce the cooling function or even cause vehicle or engine damage in worse conditions.

Replenish Cooling Water (Fill the Reserve Water Tank)

1. Stand the vehicle upright on level ground.
2. Open Reserve Water Tank (remove screw 1 and cover 2), replenish water to Upper Limit.

If level of cooling water gets excessively low, something must be wrong. Go to a KYMCO Dealer for check and repair.

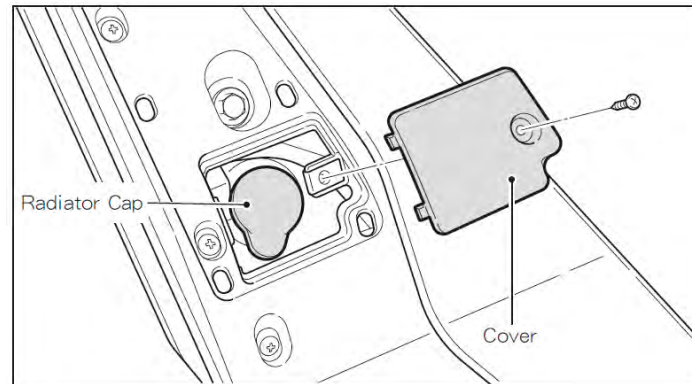

NOTICE

- ◆ Water temperature is very high after riding, do not open the cap of water tank.
- ◆ Use soft water for mixing cooling liquid.
- ◆ Using poor quality cooling water may shorten the service life of water tank. Please be careful.
- ◆ Replace cooling water in the tank every 10000km.
- ◆ Add proper amount of water tank additives to ensure performance of the cooling system.

In case of fault of vehicle:

Go to a KYMCO dealer for check and repair if any fault occurs when riding the vehicle. Use only original parts for replacement.

Check following items if engine does not start or engine stops when riding the vehicle:

- ◆ Whether gasoline is sufficient.
- ◆ Whether Dashboard Fuel Indicator approaches E. Replenish with 95 unleaded gasoline or better.
- ◆ Whether proper method is used for starting the engine.
- ◆ Others, whether any part is faulty.

Filling

When the coolant has finished draining return the drain bolt to the water pump with a new sealing washer. Tighten the drain bolt securely with a socket.

Fill the cooling system with a mix of distilled water and KYMCO SIGMA Coolant Concentrate. Continue filling until the coolant reaches the bottom of the filler neck as shown.



- Use coolant of specified mixing rate. (The mixing rate of KYMCO coolant/distilled water is 50%.)
- Do not mix coolant concentrate of different brands.
- Do not drink the coolant, which is poisonous.
- The freezing point of coolant mixture shall be 5 °C lower than the freezing point of the riding area.

Add coolant to the reserve tank until it reaches the upper level mark.

Gently rock the vehicle side-to-side to release any air bubbles trapped in the cooling system.

Place the vehicle on its center stand and start the engine. Let it run for several minutes. This will purge any air out of the cooling system. Check for coolant leaks



When the air bubbles stop coming up turn off the engine and recheck the coolant level, add coolant if necessary. Check the reserve tank and add coolant if needed. Wet the seal of the radiator cap and install.

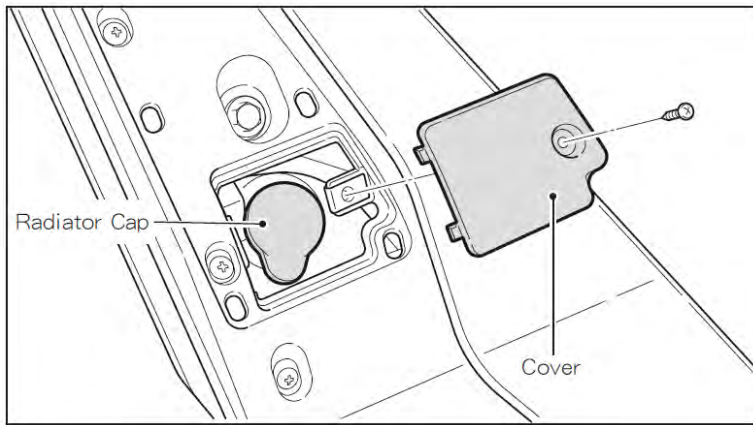

Open the coolant reserve tank lid. Siphon the coolant out of the reserve tank with an appropriate suction device. If a suction device is unavailable remove the reserve tank and pour it out. See the Radiator topic for more information.

When the coolant has finished draining, return the drain bolt to the water pump with a new sealing washer.



Tighten the drain bolt securely with an 8 mm socket.

Filling

Coolant capacity	
Radiator	1450cc
Reserve tank	250cc
Total capacity	1700cc

- Use coolant of specified mixing rate. (The mixing rate of 860cc coolant concentrate + 859cc distilled water is 50%.)
- Do not mix coolant concentrate of different brands.
- Do not drink the coolant, which is poisonous.

COOLANT MIXTURE (WITH ANTI-RUST AND ANTI-FREEZING EFFECTS)			
Freezing Point	Mixing Rate	Coolant Concentrate	Distilled Water
-9°C	20%	340 cc	1360 cc
-15°C	30%	510 cc	1190 cc
-25°C	40%	680 cc	1020 cc
-37°C	50%	850 cc	850 cc
-44.5°C	55%	935 cc	765 cc

- The freezing point of coolant mixture shall be 5°C lower than the freezing point of the riding area.

Fill the cooling system with a mix of distilled water and Coolant Concentrate. Continue filling until the coolant until it reaches the bottom of the filler neck as shown.

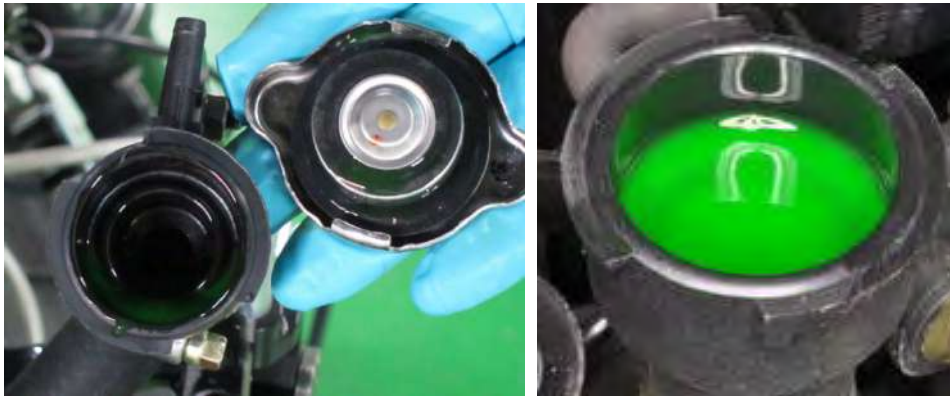

Add coolant to the reserve tank until it reaches the upper level mark.

Gently rock the vehicle side-to-side to release any air bubbles trapped in the cooling system.

Place the vehicle on its center stand and start the engine. Let it run for several minutes. This will purge any air out of the cooling system. Check for coolant leaks

When the air bubbles stop coming up turn off the engine and recheck the coolant level, add coolant if necessary. Check the reserve tank and add coolant if needed.

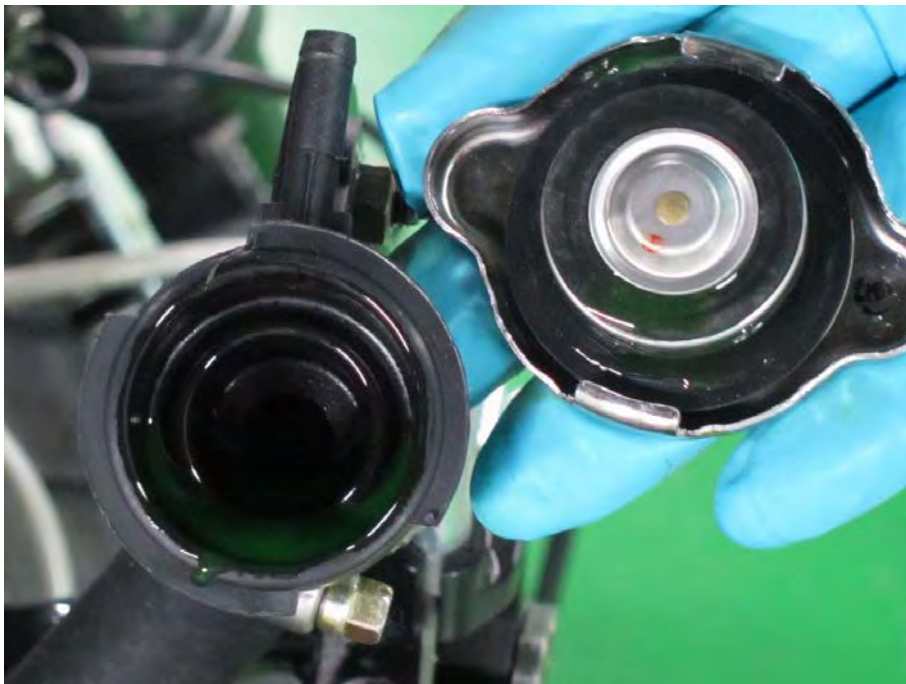

Wet the seal of the radiator cap and install.

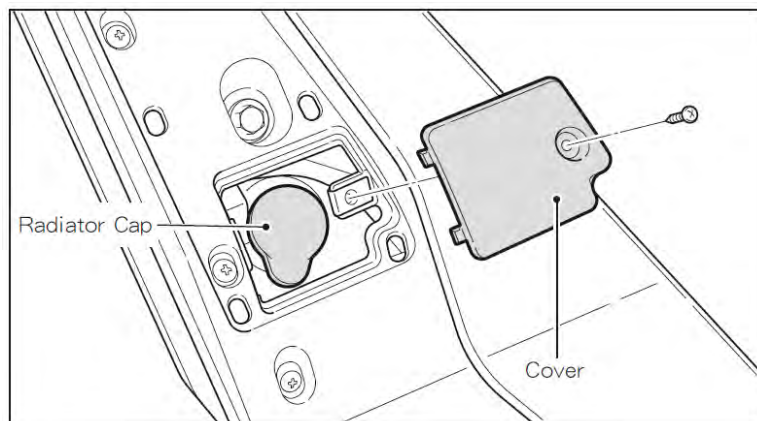

Radiator

SAFETY FIRST: Protective gloves and eyewear are recommended at this point.

Warning: Allow the engine sufficient time to cool before handling or working on the cooling system components.

Pressure Testing

Remove the radiator coolant panel screws with a #2 Phillips screwdriver.

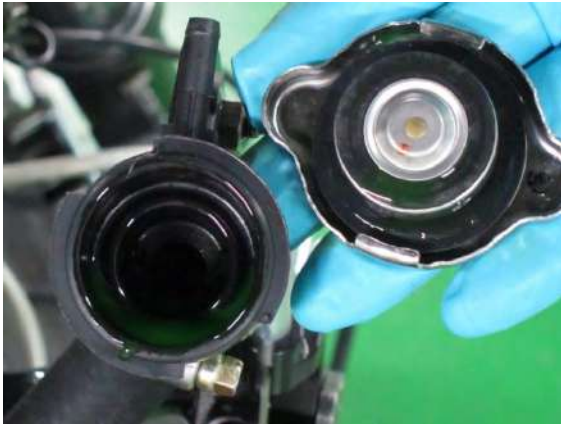

Remove the panel to access the radiator cap.

Remove the radiator cap in two stages. Allow any built up pressure to vent and then open the cap all the way and remove it.

When checking the cooling system for leaks you will need a pressure tester. Remove the radiator cap, wet the tester seal, and install the end of the pressure tester onto the filler neck. Pump the tester up until the gauge reads 0.84 kg/cm² or 12 psi. The cooling system should hold this pressure for at least 6 seconds. If it does not you will need to inspect the entire system for leaks. Do not pressurize the cooling system more than 1.05 kg/cm² or 14.9 psi.

CAUTION: Never remove the radiator cap when the engine is hot.

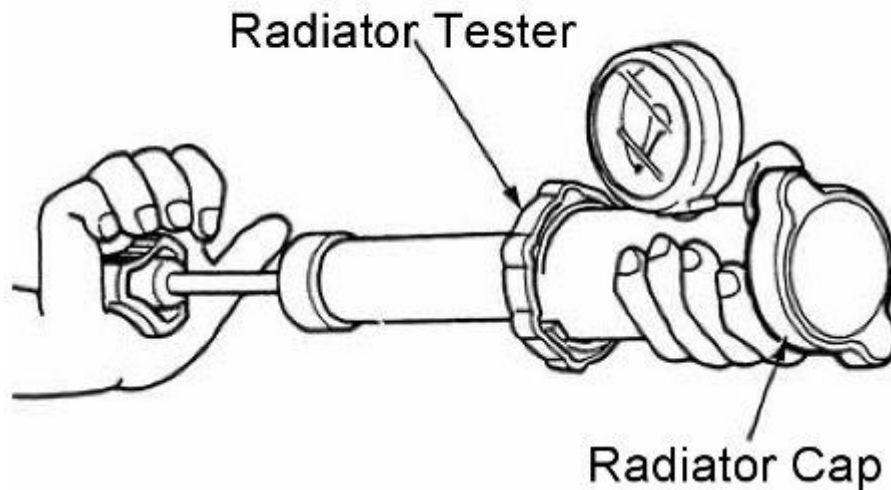

Wet the seal on the radiator cap and install it to the pressure tester.
Replace the cap if it does not relieve the pressure as specified.

Radiator cap relief pressure	$0.9 \pm 0.15 \text{ kg/cm}^2$ ($12.8 \pm 2.1 \text{ psi}$)
------------------------------	---

Removal



Unplug the cooling fan motor connector.

There are two coolant hoses that connect to the radiator. The top left hose runs to the filler neck and cap. The top right hose runs to the thermostat on the cylinder head. The bottom left hose runs to the water pump.



Loosen the coolant hose clamps with a #2 Phillips screwdriver.

Remove the hose from the radiator.

Remove the two radiator bottom mounting bolts with a 10 mm socket.

Inspection

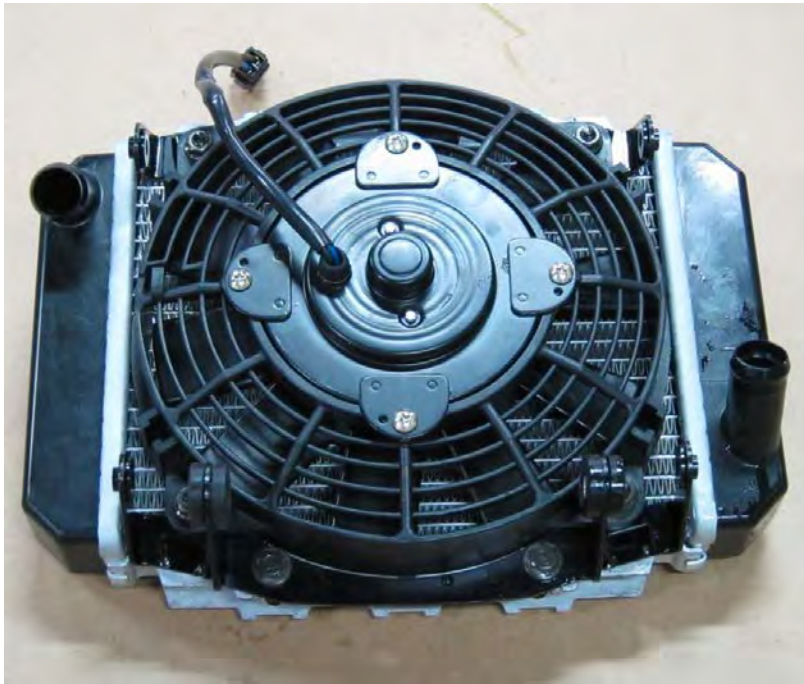

Inspect the radiator fins for damage and clogging. To remove the fan be taken out the four mounting bolts with a 10 mm socket.

Clean out the fins with low pressure compressed air and water.

NOTE: Always wear safety glasses when using compressed air and never point it directly at yourself or anyone else.



Check the radiator for any bent or damaged fins. Use a small flat blade screwdriver to straighten them out, but be careful not to puncture the radiator.

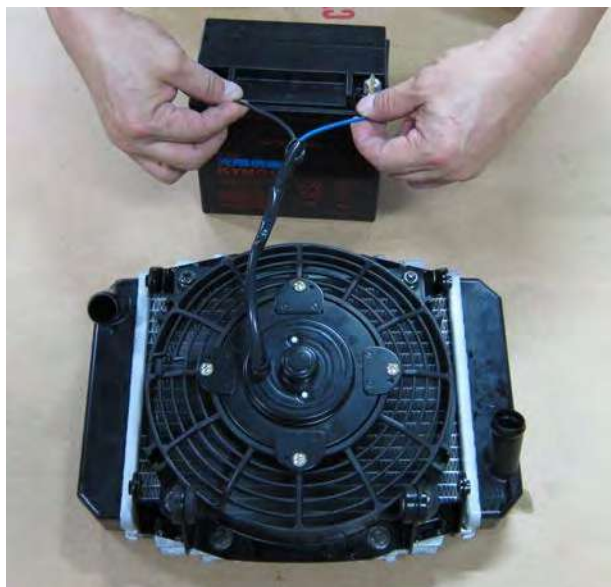

Jump a 12 volt battery to the fan connector and make sure the radiator fan operates.

Water Temperature Sensor and Thermostat

SAFETY FIRST: Protective gloves and eyewear are recommended at this point.

Removal

Water Temperature Sensor (WTS)

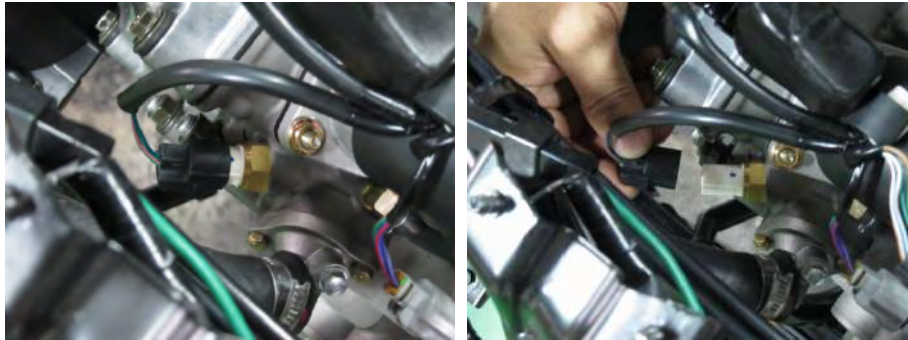

Unplug the water temperature sensor.



Use a 17 mm wrench to remove the water temperature sensor.

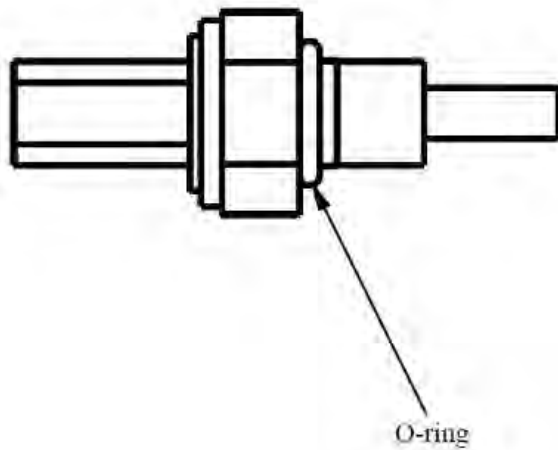

Discard the WTS O-ring and replace it with a new item.

Thermostat

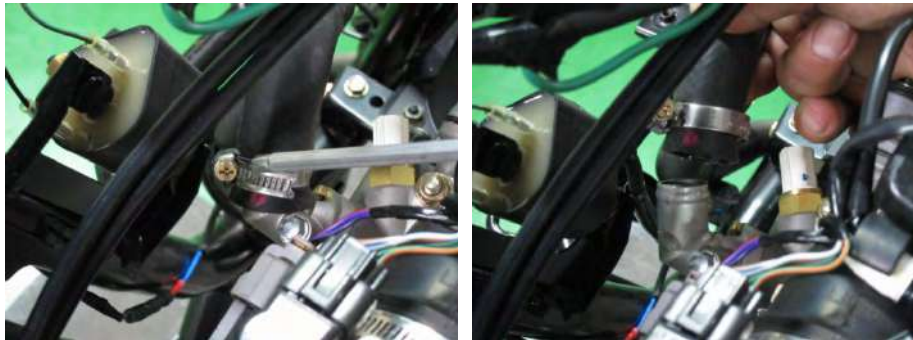

Loosen the thermostat hose clamp with a #2 Phillips screwdriver.
Slide up the clamp and free the coolant hose from the thermostat.



Squeeze the air bleed hose clamp with needle nose pliers and slide back the clamp. Free the air bleed hose from the thermostat.



Remove the two thermostat mounting bolts with an 8mm socket.



Lift off the thermostat cover.



Lift out the thermostat. Remove the thermostat O-ring and discard it.

Inspection

Water Temperature Sensor

Inspect the WTS in a similar manner as the thermosensor. Measure the resistance between the WTS terminals and compare this to the specifications.

WTS resistance	At -20 °C/-4 °F	18.8 kΩ
	At 40 °C/104 °F	1.136 kΩ
	At 100 °C/212 °F	0.1553 kΩ

Thermostat

The thermostat should be closed at room temperature.

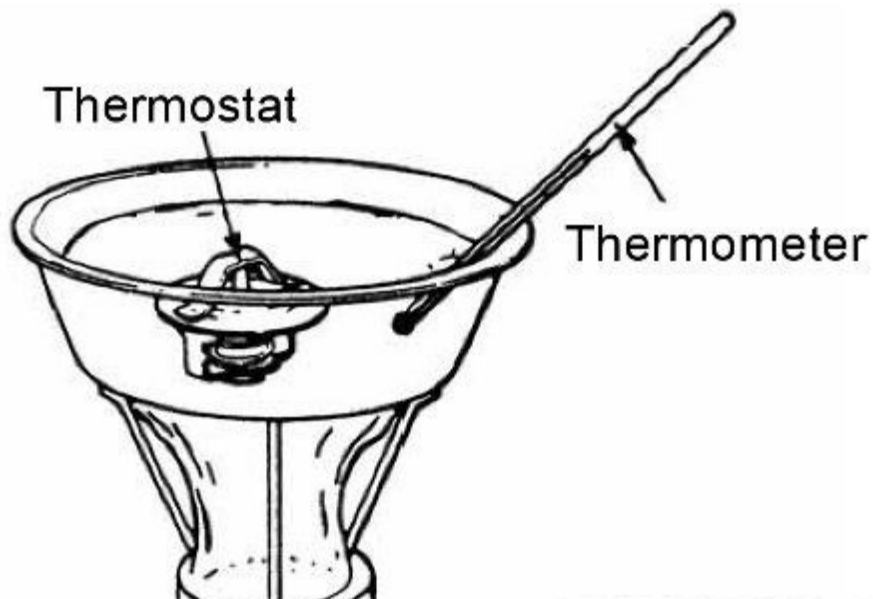

Suspend the thermostat and a thermometer in a pot of water with string. Make sure the thermostat and the thermometer are not touching the pot. Bring the temperature up to the specification slowly and check the operation of the thermostat.

The valve should begin to open around 71° C (160° F). The valve should lift 3.5 - 4.5 mm (0.14 - 0.18 in) at 80° C (176° F).

After the thermostat has been open for around 5 min. allow the thermostat to cool. The thermostat should close at 70° C (158° F).

Replace the thermostat with a new unit if it fails to function properly.

6.Fuel Injection System

This chapter covers the location and servicing of the fuel system components for the KYMCO XCITING S 400 model.

GENERAL INSTRUCTIONS	6-2
TROUBLESHOOTING	6-3
COMPONENT LOCATION	6-4
ECU	6-7
IGNITION COIL	6-9
SPARK PLUG	6-12
CRANK POSITION SENSOR	6-14
O2 SENSOR	6-15
RELAYS	6-16
FUEL TANK	6-17
THROTTLE BODY	6-27
FUEL INJECTOR	6-31
THROTTLE BODY DISASSEMBLY	6-36
TILT SWITCH	6-37
SELF-DIAGNOSIS	6-39
DIAGNOSTIC TOOL	6-40
FAILURE CODE	6-46
DIAGNOSTIC REPORT	6-50

GENERAL INSTRUCTIONS

- Scooter services can be done with the engine installed in the frame.
- Be sure to relieve the fuel pressure before fuel pump or fuel hose removal.
- Bending or twisting the control cables will affect operation and could cause the cables to stick or bind, resulting in loss of vehicle control.
- Work in a fully ventilated area. Smoking or allowing flames or sparks in the work area or where gasoline is stored can cause a fire or explosion.
- Do not apply the Carburetor Cleaners to the inside of the throttle body, which is coated with molybdenum.
- Do not snap the throttle valve from fully open to fully close after the throttle cable has been removed; it may cause incorrect idle speed.
- Do not loosen or tighten the painted bolts and screws of the throttle body. Loosening or tightening them can cause throttle and idle valve synchronization failure.
- Seal the cylinder head intake ports with tape or a clean towel to prevent dirt and debris from entering the intake ports after the throttle body has been removed.
- Do not damage the throttle body. It may cause incorrect throttle and idle valve synchronization.
- Do not take the fuel pump on the ground downward.

- Always replace the packing when the fuel pump is removed.

- The electronic fuel injection system is equipped with the self-diagnostic system. If the Check Engine Lamp “CELP” illuminate while riding, follow the self-diagnostic procedures to solve the problem.

- A faulty AFI problem is often related to poorly connected or corroded connectors. Check those connections before proceeding.

- When disassembling the fuel injection parts, note the location of the O-rings. Replace them with new ones upon reassembly.

- Do not disconnect the battery negative (-) or positive (+) cable while engine is running, it may cause ECU damage.

- **Do not disconnect or connect the ECU connector during the ignition switch “ON”; it may cause the ECU damage.**

TROUBLESHOOTING

Engine fail to start

- Intake manifold air leak
- Fuel contaminated/deteriorated
- Pinched or clogged fuel hose
- Faulty fuel pump
- Clogged fuel filter, throttle body
- Sticking fuel injector needle
- Faulty fuel pump operating system
- Carbon deposit stayed on the fuel injector
- Spark plug dirty
- Fuel pressure incorrect

Backfiring or misfiring during acceleration

- Ignition system malfunction

Engine stall, hard to start, rough idling

- Intake air leak
- Fuel contaminated/deteriorated
- Pinched or clogged fuel hose
- Idle speed fail to adjust
- Fail to perform TPS/ISC reset

Poor performance (drive ability) and poor fuel economy

- Pinched or clogged fuel hose
- Faulty injector

Component Location

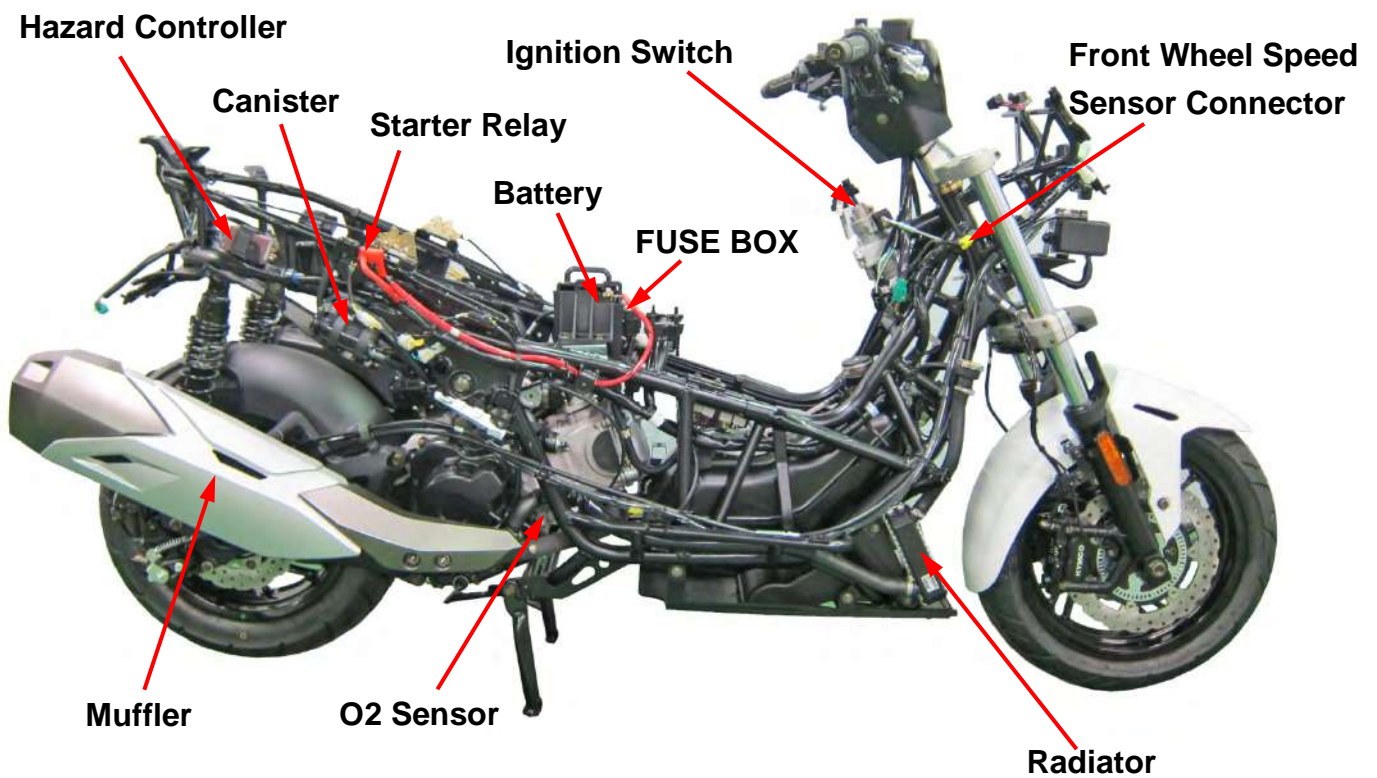
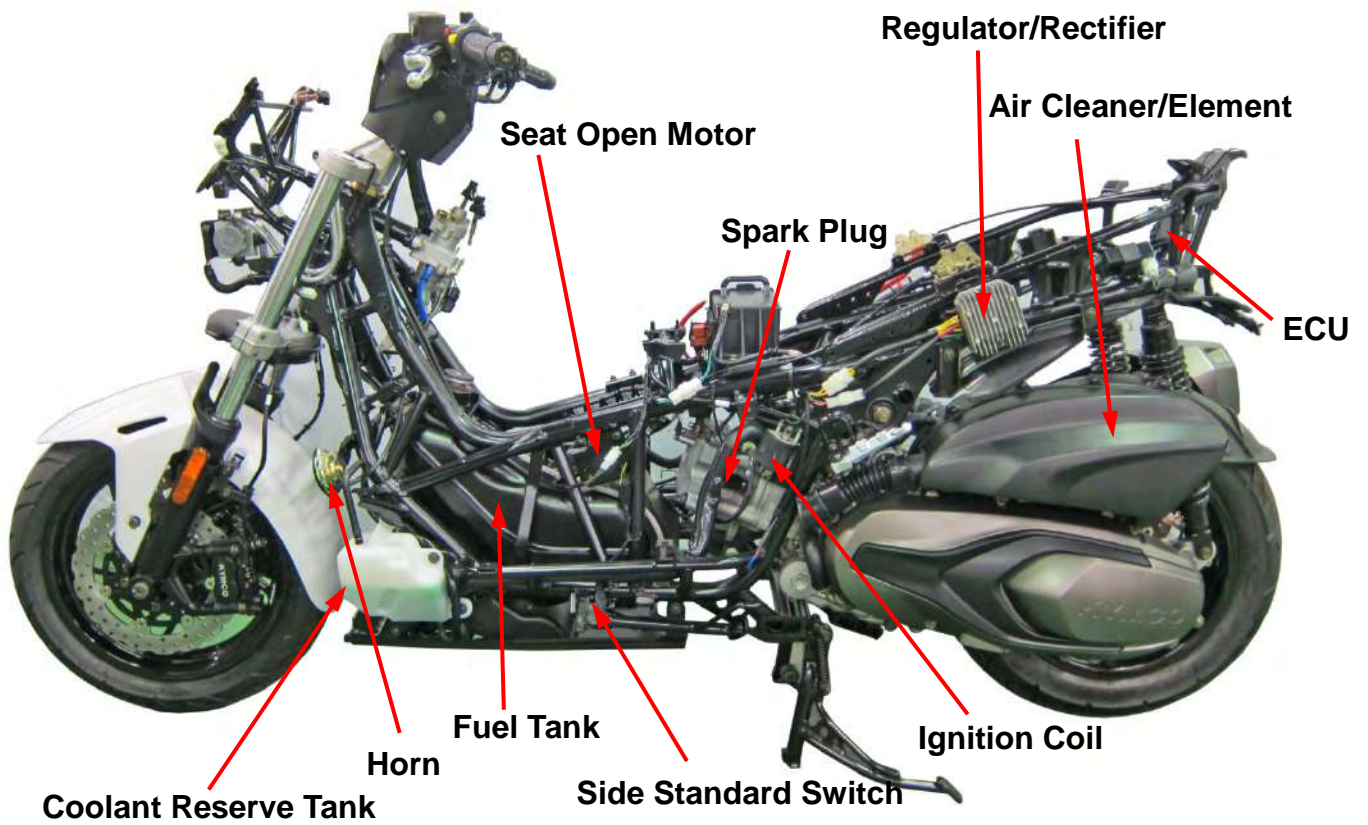

Component Location

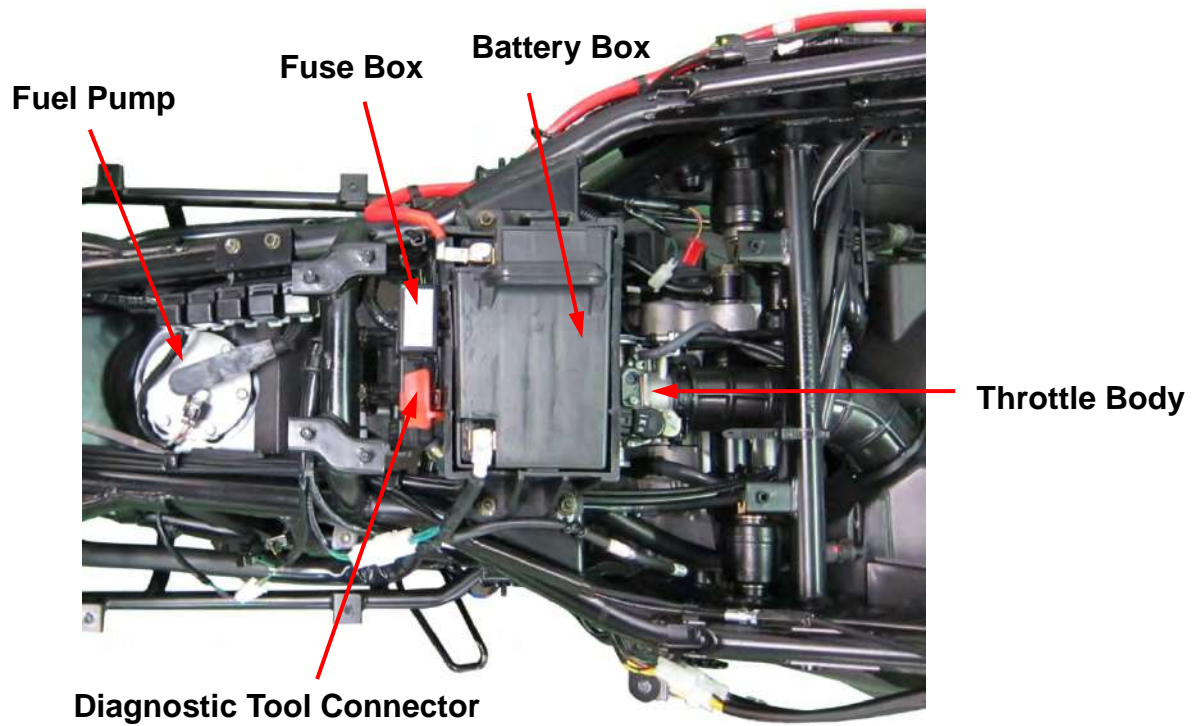
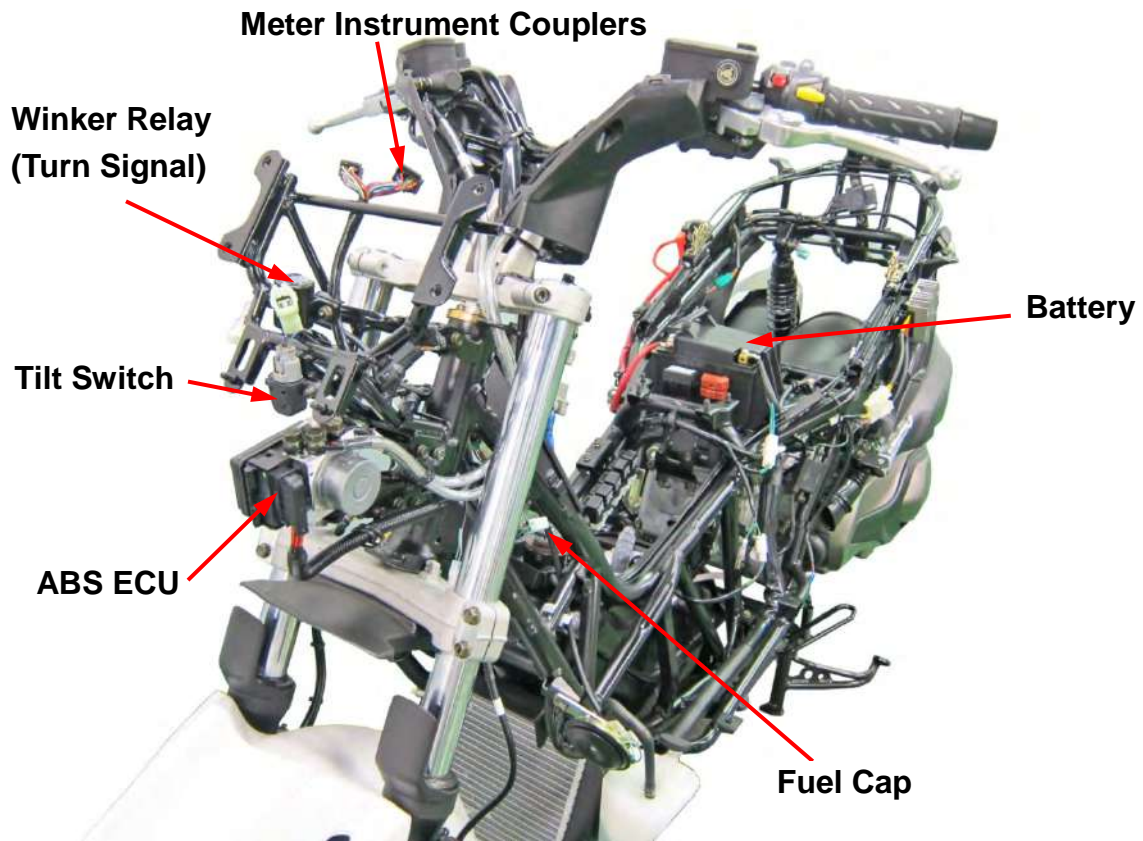

Component Location

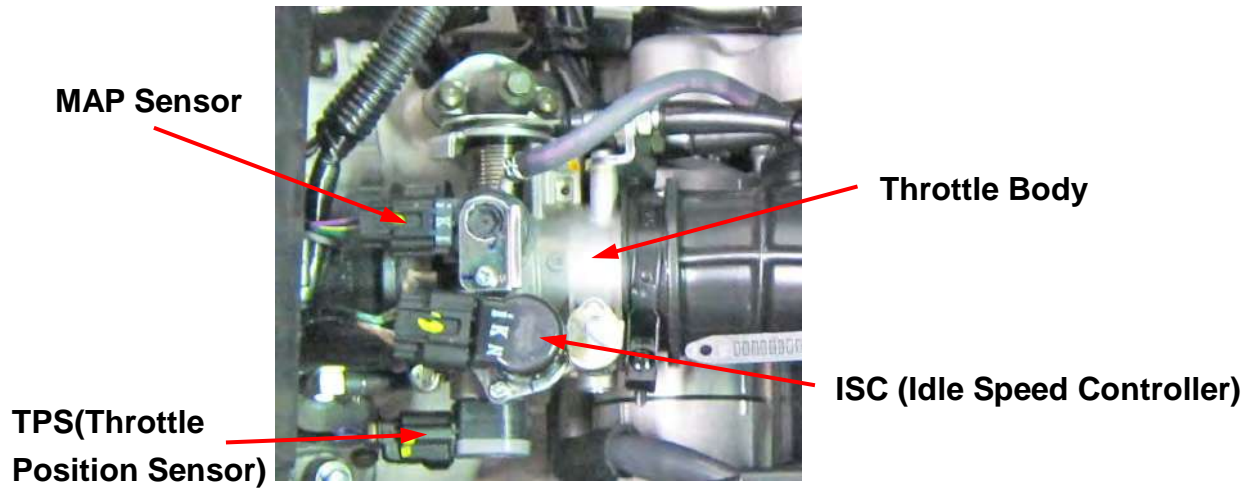

Seat Open Motor Relay/ Starter Relay/ Fuel Pump Relay/ ECU Relay/ Fan Relay
(The location refer to the wiring diagram wire color)

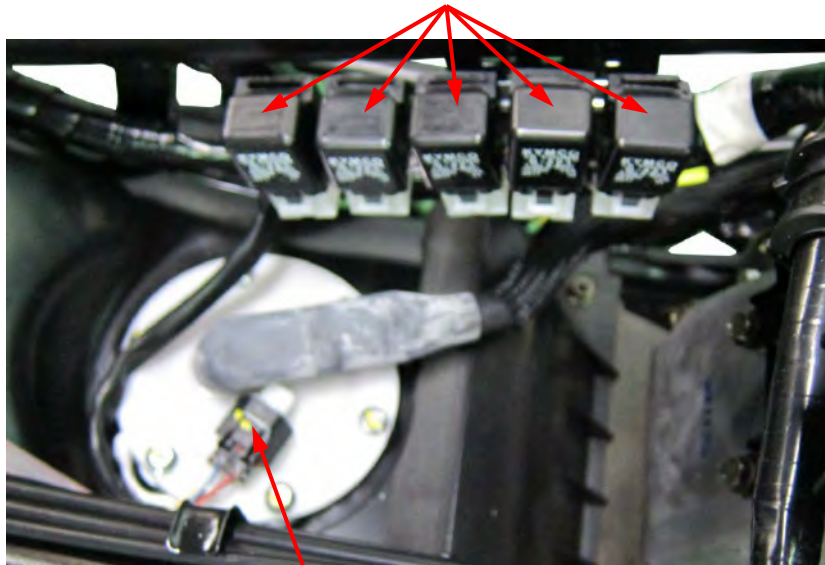

Fuel Pump

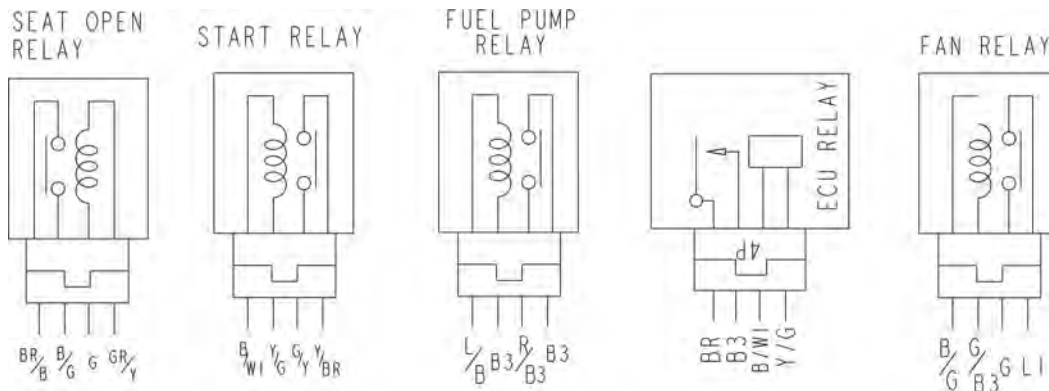

ECU

Note: The ECU could be damaged if dropped or the connector is disconnected when the key is on. The excessive voltage may damage the ECU. Always turn off the ignition switch before servicing.

Press the tab and disconnect the ECU coupler.



Remove the two nuts to remove the ECU.

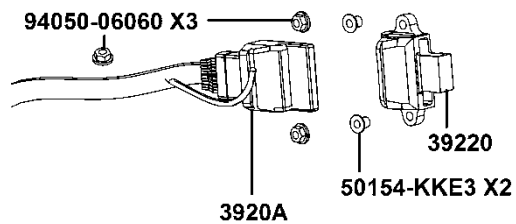
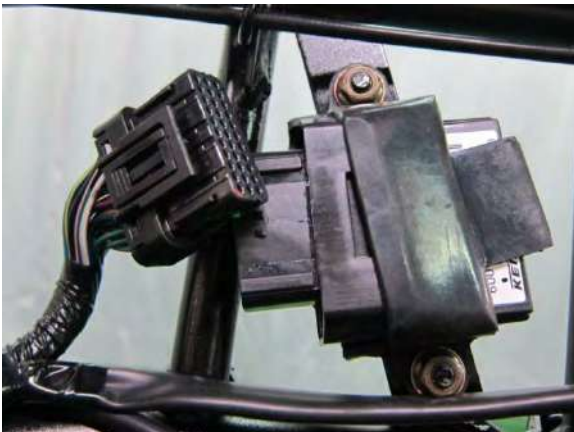

Inspection

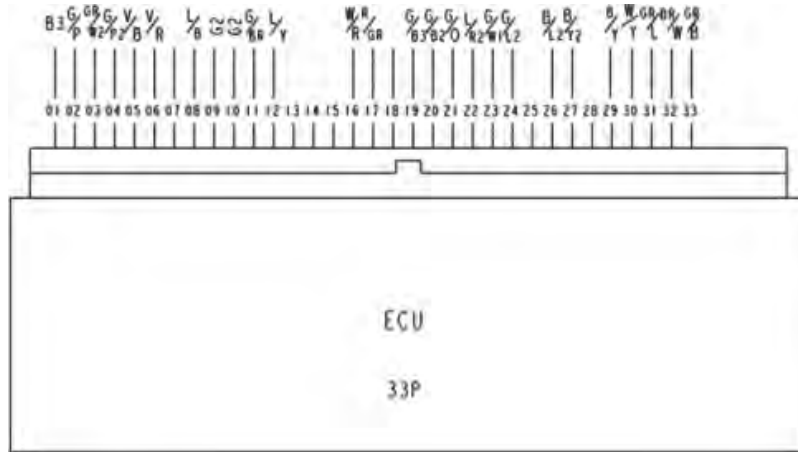

Check for continuity between pin 9 and 10 of the ECU side connector.

There should be continuity at all times.

Check for continuity between each pins 2,4 and 23 of the ECU side connector.

There should be continuity at all times.

PIN NO.	NAME	FUNCTION	PIN NO.	NAME	FUNCTION
01	IGP	IGNITION POWER	19	FAN	FAN RELAY
02	LGI	LOGIC GROUND 1	20	ISCBP	IDEL SPEED CONTROL B
03	HEGO	HEGO SENSOR	21	ISCAP	IDEL SPEED CONTROL A
04	SG	SENSOR GROUND	22	MIL	MULTI INDICATOR LAMP
05	TH	THROTTLE POSITION SENSOR	23	CRK-M	CRANK PULSE SENSOR GND
06	VCC	SENSOR POWER OUTPUT(+5V)	24	TW	WATER TEMP. SENSOR
07	-	-	25	-	-
08	FLPR	FUEL PUMP RELAY	26	ROLL	ROLL SENSOR
09	PG1	POWER GROUND 1	27	PM	MANIFOLD PRESSURE SENSOR
10	PG2	POWER GROUND 2	28	SOL	-
11	IG	IGNITION COIL	29	NE	METER
12	CRK-P	CRANK PULSE SENSOR	30	K-LINE	DIAGNOSTIC TOOL
13	-	-	31	ISCBN	IDEL SPEED CONTROL / B
14	TA	AIR TEMP. SENSOR	32	ISCAN	IDLE SPEED CONTROL / A
15	TEST	-	33	HEGO HT	HEGO SENSOR HTATER
16	INJ	INJECTION			
17	VSP	VEHICLE SPEED SENSOR			
18	-	-			

Ignition System

The ignition timing is set at the factory and is not adjustable. Perform the following checks. Before performing any tests make sure the electrical connections are not loose or corroded.

Ignition Coil

Remove the connectors.

Remove the two ignition coil mounting bolts and remove the ignition coil.

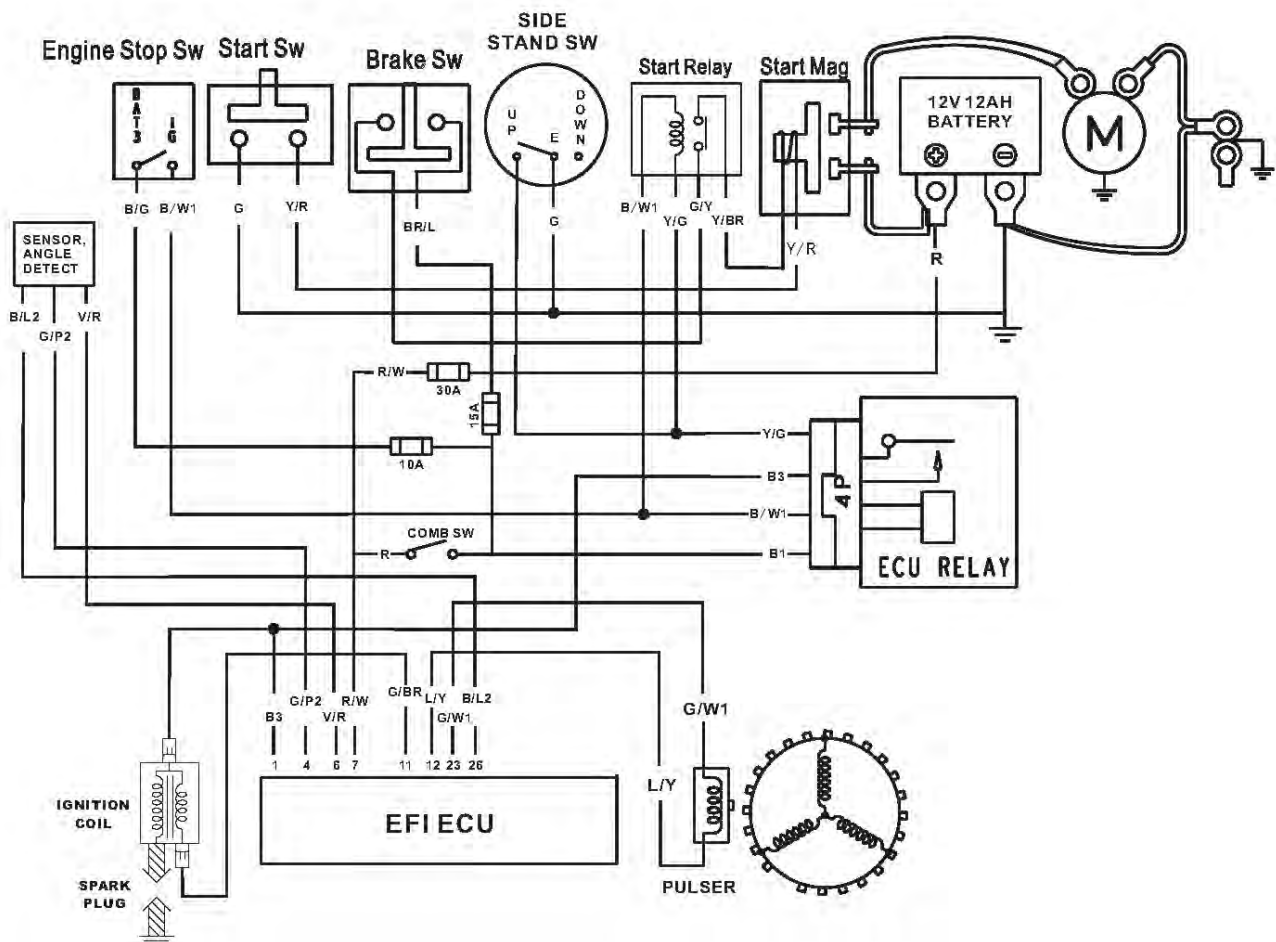

Ignition Coil Resistance

Primary

Set the multimeter to read ohms of resistance (Ω).

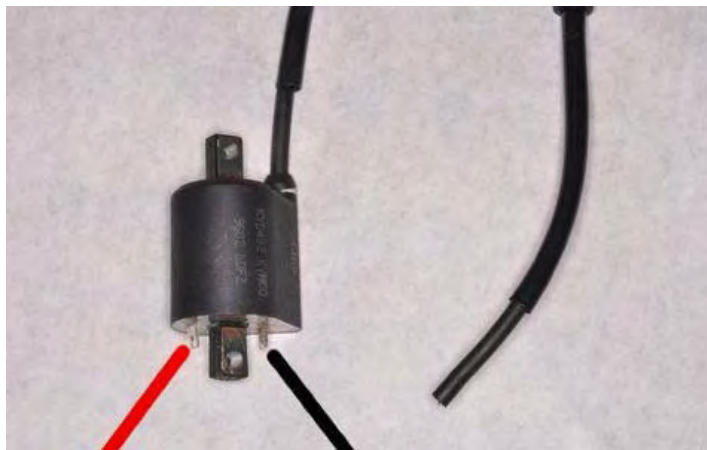

Touch the positive and negative meter leads to the ignition coil terminals as shown. Measure the resistance.

Ignition Coil Primary Resistance	3.57 - 4.83 Ω
----------------------------------	----------------------

Secondary With Plug Cap

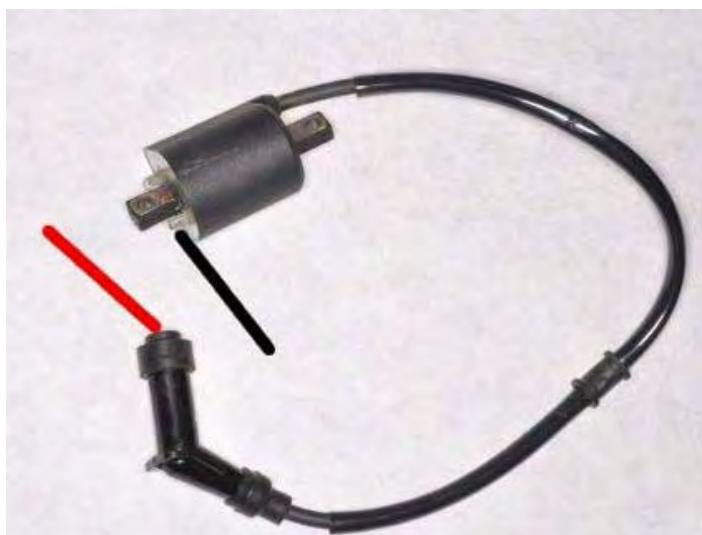

Check the secondary resistance between the ignition coil terminal and the spark plug cap. Touch the negative meter lead to the terminal and the positive meter lead to the spark plug cap as shown.

Secondary Resistance With Plug Cap	15 - 19 Ω
------------------------------------	------------------

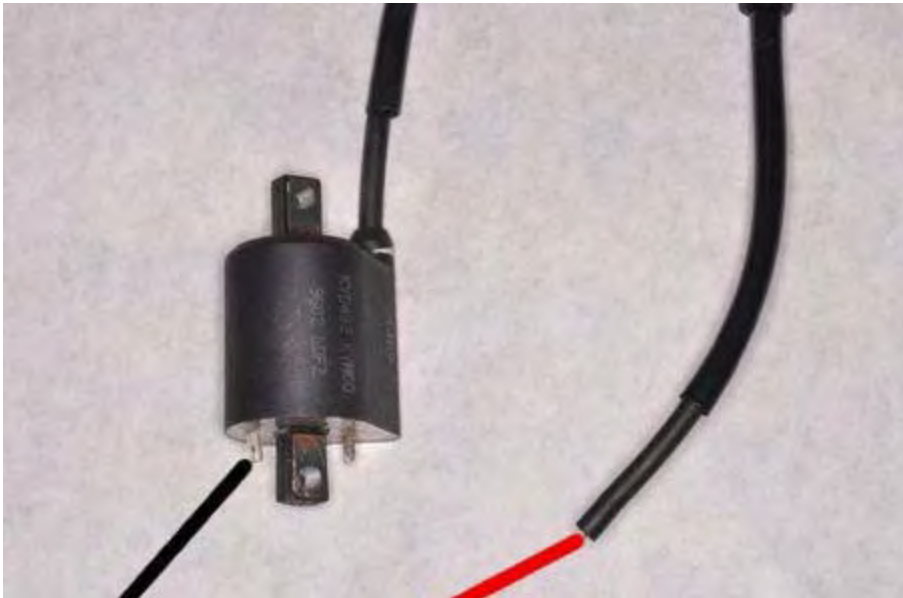
Secondary Without Plug Cap

Check the secondary resistance between the ignition coil terminal and the spark plug wire without the cap. Touch the negative meter lead to the terminal and the positive meter lead to the spark plug wire as shown.

Secondary Resistance Without Plug Cap	10 - 14 Ω
---------------------------------------	------------------

Spark Plug

Turn the ignition switch to ON, lift the side stand, hold in one of the brake levers, and push the engine start button. The plug should spark.

Caution: Do not touch the spark plug or spark plug wire while cranking or running the engine as this can result in a severe shock.

Remove the spark plug with a spark plug with a 5/8 in socket.



Spark plug	NGKCR7E
------------	---------

Check the spark plug to see if it is the correct type and gapped properly. If the spark plug is black and fouled, replace it.

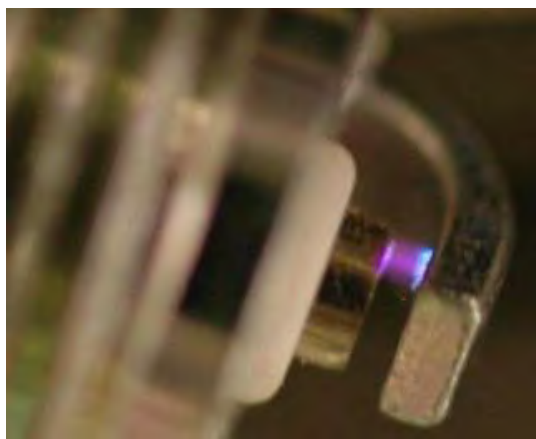

If the spark plug center electrode or side electrode are corroded or damaged, or if the insulator is cracked, replace the plug.

Measure the gap with a wire-type thickness gauge.
If the gap is incorrect, replace the spark plug.

Always check the gap of the spark plug before installation. Inspect the color of the porcelain nose of the spark plug. The color of the spark plug can indicate how the mixture is burning. A white colored plug shows a lean mixture, where a dark plug shows a rich mixture. Do not hesitate to replace a spark plug. Always replace a spark plug if any part of it is damaged.

Spark plug gap	0.7~0.8 mm
----------------	------------

Do not over tighten the spark plug. The cylinder head is made out of soft metal, and it can be easily damaged.

Item	Torque
Spark plug	0.8~1.2 kgf-m

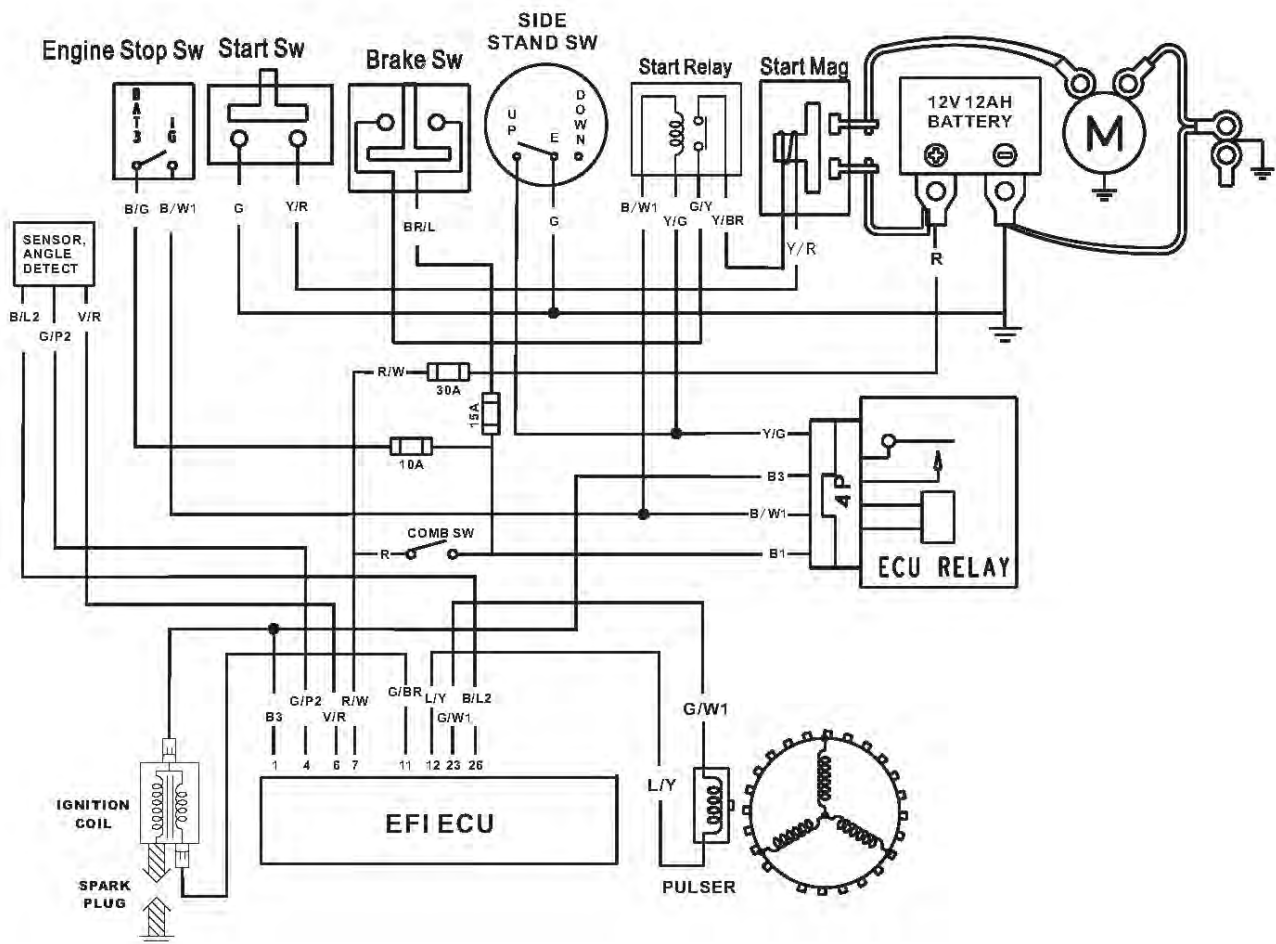

AC Generator Inspection

Crank Position Sensor Inspection

Note: This test is performed with the stator installed in the engine.
 Disconnect the crank position sensor wire coupler. Measure the resistance between L/Y and G/GR wire terminals.



Resistance	
L/Y – G/GR	115 Ω ± 15 Ω

CHARGING SYSTEM

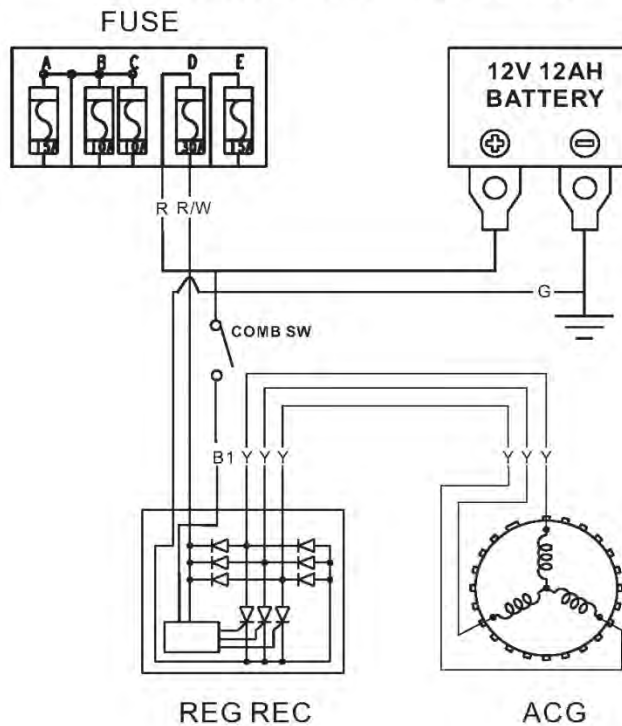

O₂ Sensor Removal

Remove the O₂ sensor with a 17 mm wrench. Use care not to pinch the wires.

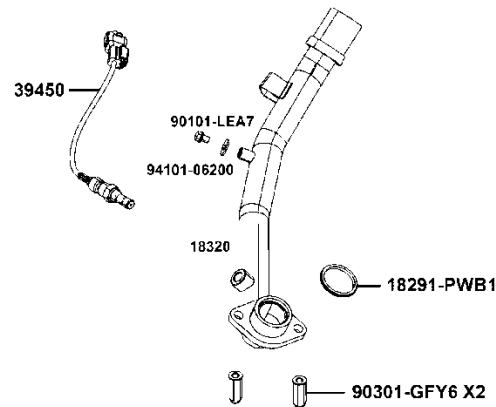

Installation torque: 2~3 kgf-m (20~30 N-m)

Apply anti-seize compound to the threads of the O₂ sensor. Install the O₂ sensor and tighten it to specification with a 17 mm wrench. Use care not to pinch the wires.

The O₂ sensor issues signal to ECU when the temperature is over 350°C while the engine is running.

Test the O₂ sensor at room temperature.

Use a digital multimeter set to ohms of resistance to inspect the O₂ sensor.

Measure the resistance between the white wire terminals of the O₂ sensor connector. Replace the O₂ sensor if the reading is out of specification.

ITEM	SPECIFICATIONS
O ₂ heater sensor resistance (at 20°C/68°F)	12 - 18 Ω (engine warming condition)

Relays

Seat Open Motor Relay/ Starter Relay/ Fuel Pump Relay/ ECU Relay/ Fan Relay
(The location refer to the wiring diagram wire color)

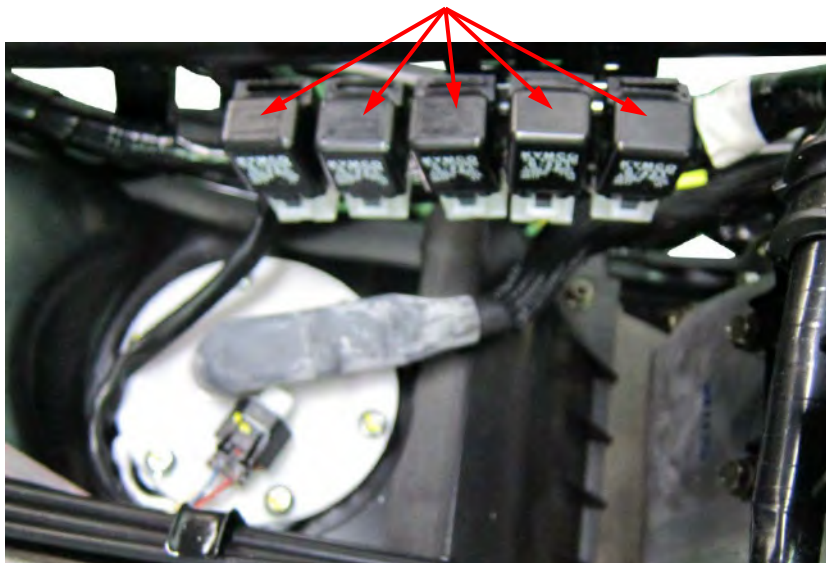

Relays Inspection

Use a digital multimeter to inspect the relay.

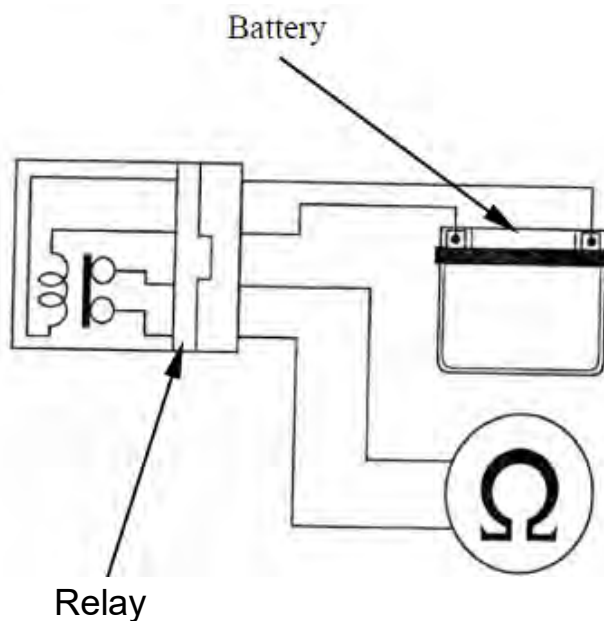

Connect 12 V battery with the fuel cut-off relay connector.

There should be continuity only when 12 V battery connected.

If there is not continuity when the 12 V battery is connected, replace the relay.

Fuel Tank

SAFETY FIRST: Protective gloves and eyewear are recommended at this point.

Warning: Gas is extremely flammable! Do not work around an open flame or a source of sparks.

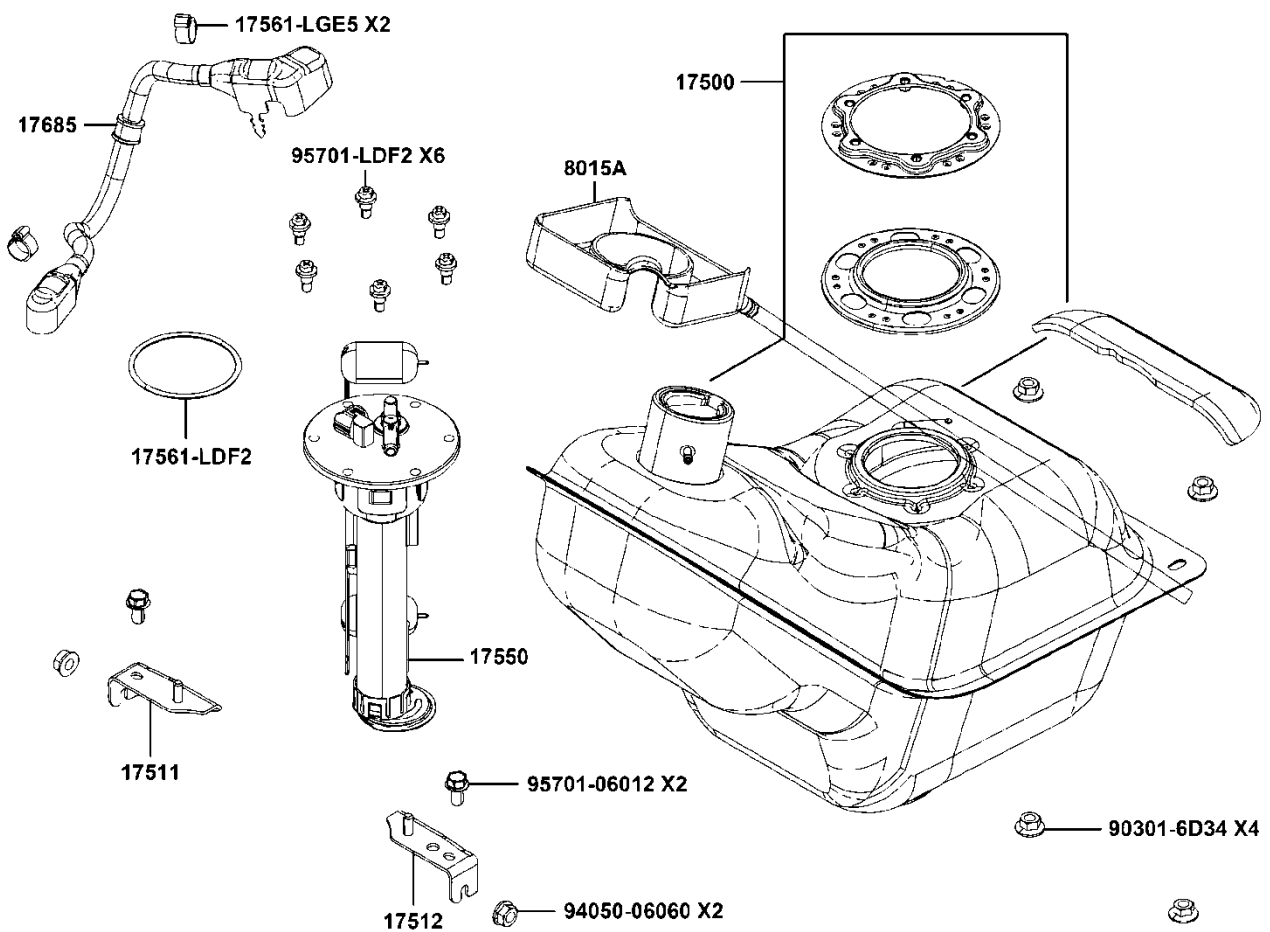

Fuel Tank Removal

In order to drain the fuel from the fuel pipe and release the fuel pressure unplug the fuel pump connector. Start the engine and let it run until it dies of fuel starvation. Turn the ignition switch off.

Disconnect the coupler.

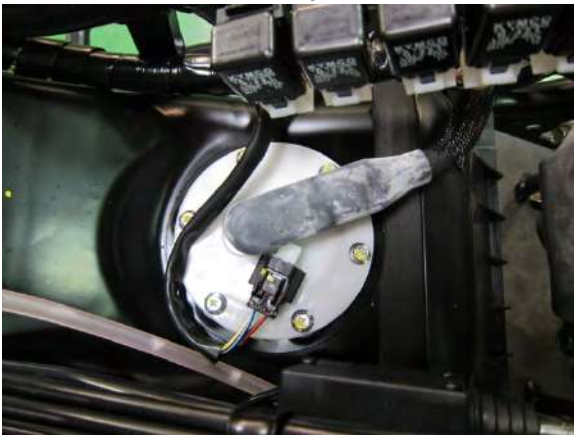

Clamp the fuel hose for safety.
And loosen the fuel hose clamp.

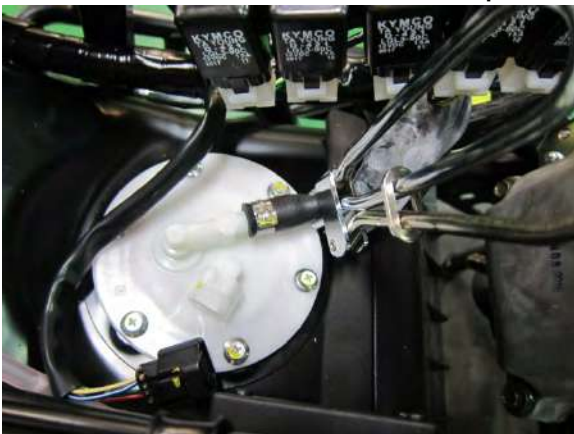

To separate the fuel hose from the fuel pump pipe.



Clean up any remaining fuel immediately.



Note: When slide back the fuel hose carefully not to damage the fuel pump pipe, and replace the clamp with a new one when installation.



Remove the fuel pump mounting bolts. And remove the fuel pump assembly.

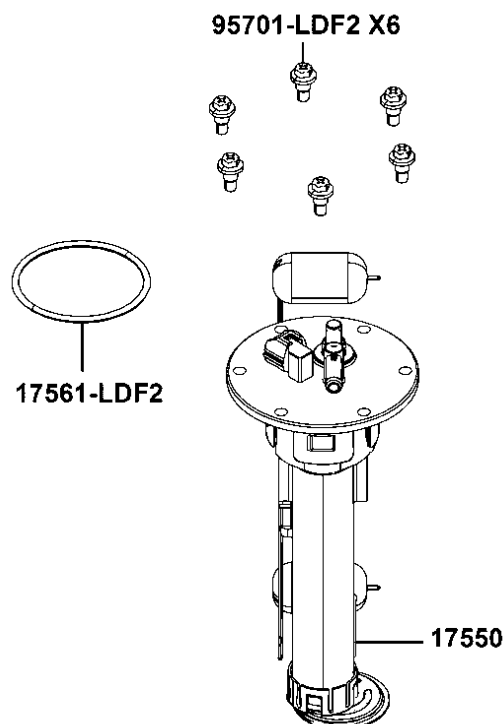

Remove the radiator.

Remove the fuel tank mounting nuts and remove the fuel tank from the frame.

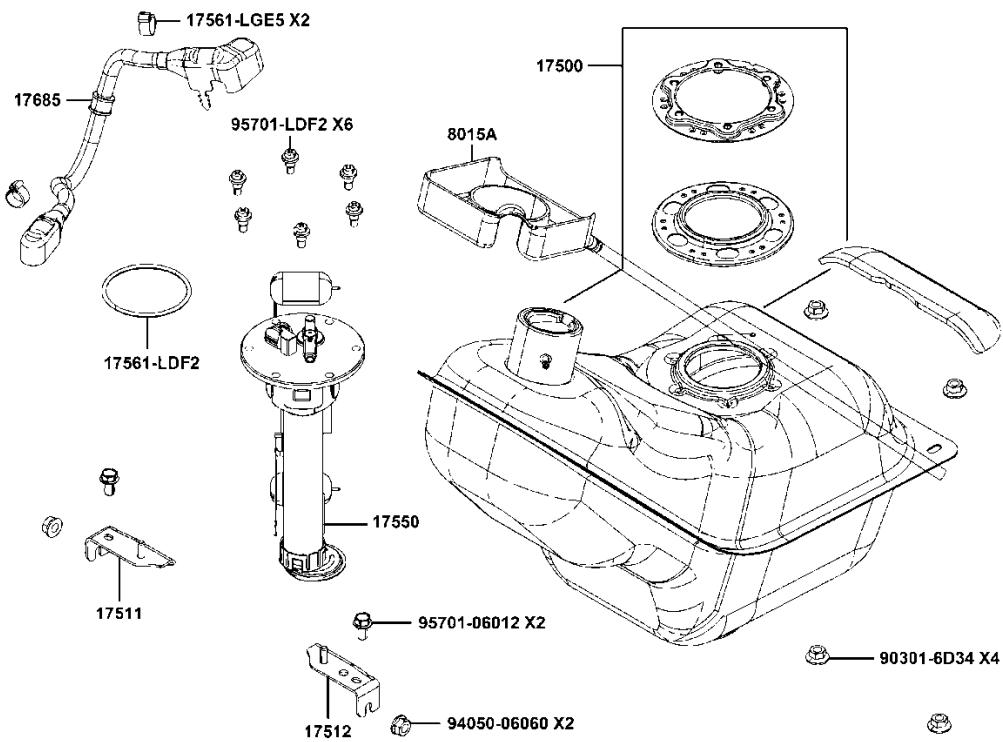

Fuel Pump

SAFETY FIRST: Protective gloves and eyewear are recommended at this point.

Warning: Gas is extremely flammable! Do not work around an open flame or a source of sparks.

Input Voltage Inspection

Turn the ignition switch off.

Place the scooter on its main stand and put the side stand up.

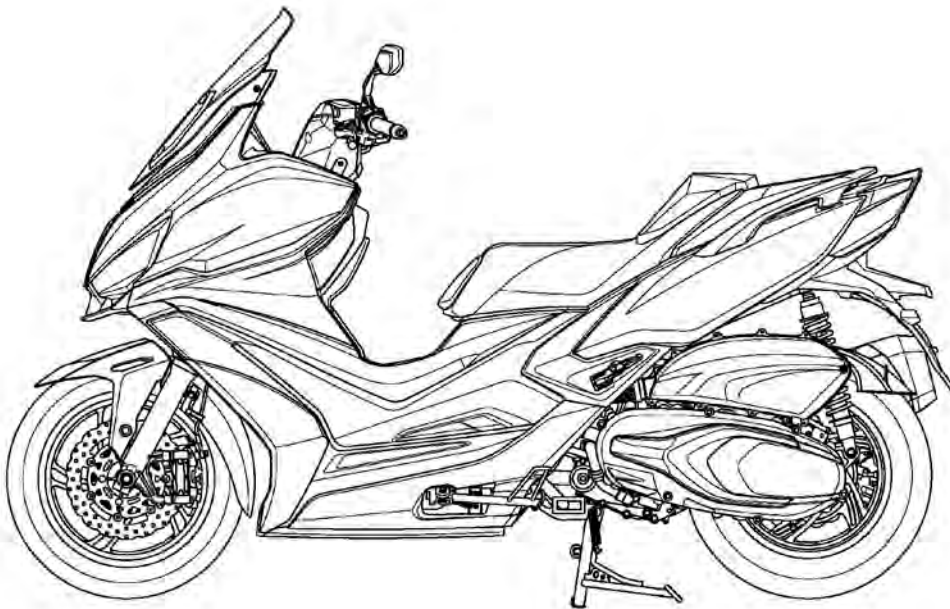

Place the scooter on its main stand and put the side stand up.

Set the engine stop switch to the “RUN” position.

Unplug the fuel pump connector.

Set the multi meter to read battery voltage.

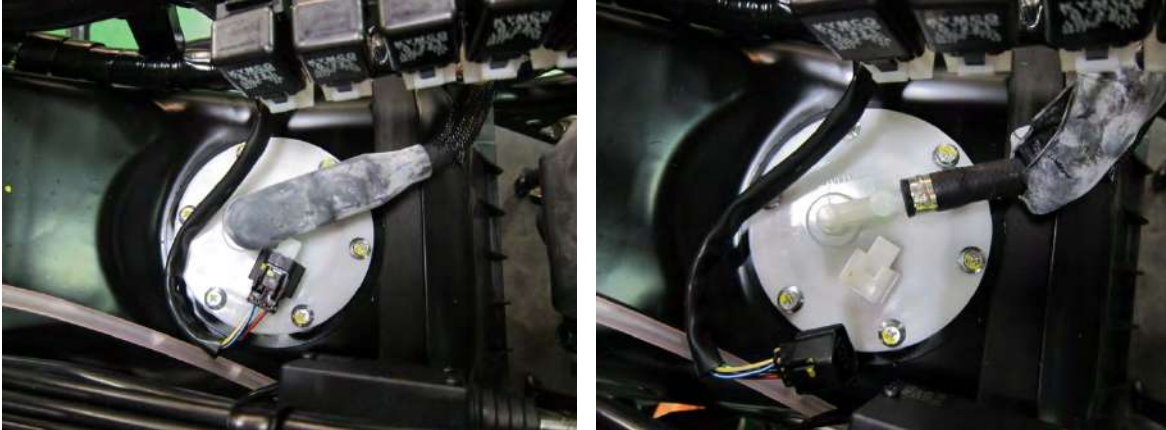

Touch the multi meter leads to the harness side of the fuel pump connector, with the positive lead touching the red/black wire terminal and the negative lead touching the green wire terminal.

Turn the ignition switch on. The battery voltage should show for a few seconds. Replace the fuel pump if it is not functioning and the input voltage is correct.

If the battery voltage is not present check the following:

- Fuse
- Fuel cut-off relay
- ECU

Fuel Pump

Lift the fuel pump out of the tank.

Discard the fuel pump O-ring, and when installation, replace the O-ring with new item and apply a small amount of fresh engine oil to the new O-ring.



Fuel Level Gauge Inspection



Using a digital multi meter set to ohms of resistance (Ω), measure the resistance between the fuel pump/level gauge connector terminals (green and yellow/white) with the float raised to the positions indicted below.

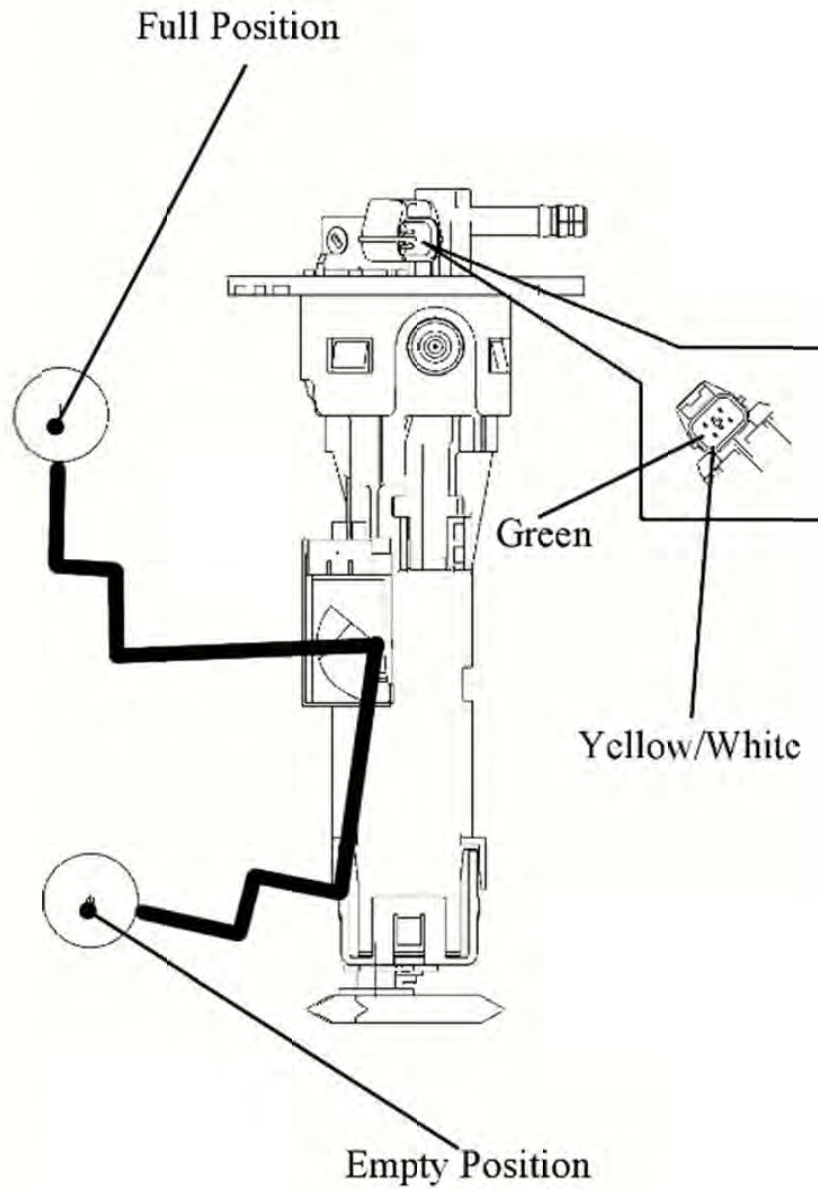

Fuel Level Float Position	Resistance
Full	$1100\Omega \pm 33\Omega$
Empty	$100\Omega \pm 3\Omega$

Replace the fuel level float unit with a new part if the resistance is out of specification.

Fuel Pump Output Pressure

Turn the key to the OFF position.
Use a fuel hose clamp as shown.



To separate the fuel hose from the fuel pump pipe.



Clean up any remaining fuel immediately. Disconnect the fuel hose from the fuel injector. Connect the fuel pressure gauge. Remove the fuel hose clamp. Turn the key to the ON position. Check the fuel pressure.

To separate the fuel hose from the fuel pump pipe.



If the fuel output pressure is less than 3.0 bar, may fail to start the engine or in trouble in case of riding.

Turn the key to the OFF position and use the fuel hose clamp to block the fuel hose. Return the fuel line to the injector.

To inspect the fuel pump relay see the Relays topic.



Throttle Body Removal

SAFETY FIRST: Protective gloves and eyewear are recommended at this point.

Inspection

Throttle Body /MAP/ISC/TPS

- Turn off the ignition switch during removal/installation.
- Check and confirm if the voltage is over 12V with a voltmeter after replacement.
- Check and confirm if the other connectors are installed correctly after replacement.
- Do not damage the throttle body, it may cause the throttle and idle valve to fail synchronization.
- The throttle body is preset in KYMCO factory, do not disassemble it incorrectly.
- Do not loosen or tighten the painted bolts and screws for the throttle body. Loosening or tightening them can cause the throttle and idle valve synchronization to fail.
- TPS and ISC have to be reset after the throttle body MAP, TPS, ISC or ECU has been reinstalled.

MAP Inspection

Support the scooter on a level surface.

Put the side stand up and engine stop switch is at "RUN". Turn the ignition switch to "ON" position.



Measure if the ECU voltage outputs to the MAP between the following terminals of the MAP connector.

Terminal	Normal
Violet/Red (+) – Green/Pink (-)	5 V

TPS Inspection

Support the scooter on a level surface.

Put the side stand up and engine stop switch is at “RUN”. Turn the ignition switch to “ON”.

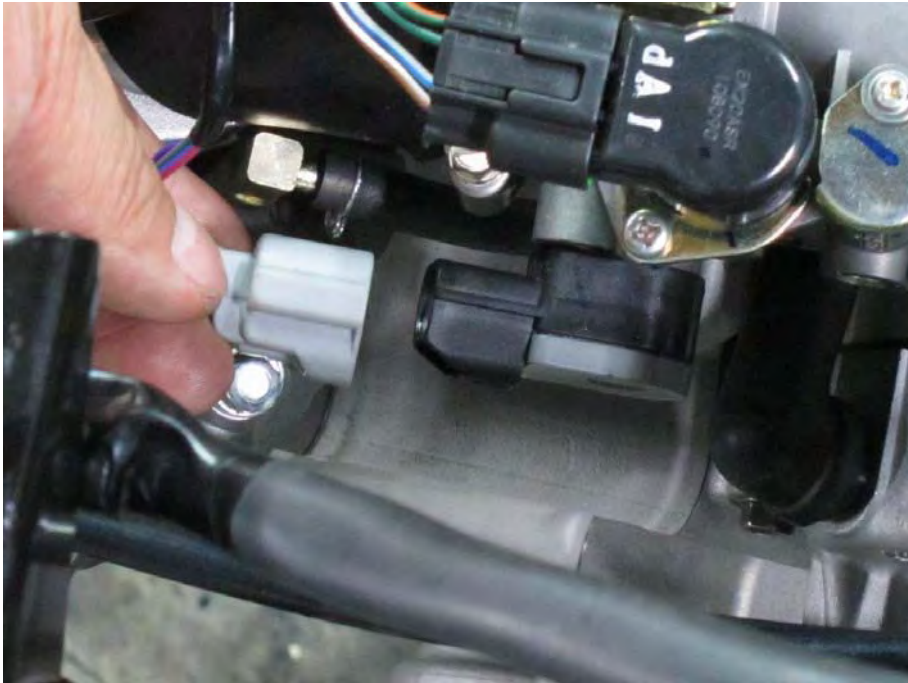

Measure if the ECU voltage outputs to TPS between the following terminals of the TPS connector.

Terminal	Normal
Violet/Red (+) – Green/Pink (-)	5 V
Throttle Position Sensor (TPS)	3500 - 6500 Ω

Removal

Throttle Cables

Free the throttle cables from the throttle drum.



Fuel Injector Removal

SAFETY FIRST: Protective gloves and eyewear are recommended at this point.

Warning: Gas is extremely flammable! Do not work around an open flame or a source of sparks.

In order to release fuel pressure from the fuel pipe when removing the fuel injector, unplug the fuel pump connector. Start the engine and let it run until it dies of fuel starvation. Turn the ignition switch off.

Clamp the fuel hose for safety. And loosen the fuel hose clamp.

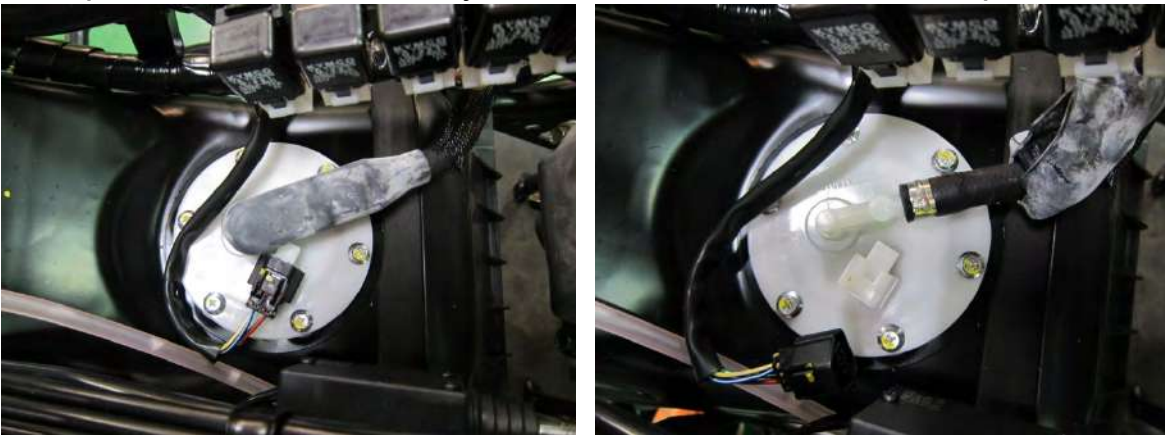

Inspect the fuel hose for signs of deterioration or damaged. Replace the fuel hose as needed.



Slide back the clamp and free the injector fuel pipe from the fuel hose. Inspect the fuel hose for signs of deterioration or damaged. Replace the fuel hose as needed.



Remove the fuel injector mounting bolt with a 10 mm socket. Unplug the fuel injector connector.



Lift the fuel injector out of the intake pipe.



Slide back the clamp and free the injector fuel pipe from the fuel hose.

Inspection

A digital multi meter is needed to test the fuel injector.

Measure the resistance between the fuel injector terminals.

ITEM	SPECIFICATIONS
Fuel injector resistance (at 20°C/68°F)	9.9 – 13.5 Ω



Check for signs of clogging.

Set the multi meter to read ohms of resistance (Ω).

When installation:



Apply a light coat of fresh engine oil to a new fuel injector O-ring.



Fit the fuel injector pipe onto the top of the injector. The tab on the injector must fit into the pipe.



Loosen the air box hose clamp screw at the throttle body with a #2 Phillips.



Loosen the intake hose clamp screw at the throttle body with a flat blade screwdriver.



Remove the sensor couplers, remove the throttle out of the air box and intake boots, then remove the throttle body.

Throttle Body

Disassembly



The throttle position sensor (TPS) and idle air bypass valve (ISC) have to be reset when the throttle body MAP, TPS, ISC or ECU have been reinstalled.

MAP Sensor



Tilt Switch

Remove the front cover. See the external topic for more information.

Support the scooter level surface.

Put the side stand up and engine stop switch on “RUN”. Turn the ignition switch to “OFF”.

Note: Do not disconnect the tilt switch connector during inspection. The capacity of battery must be fully charged.

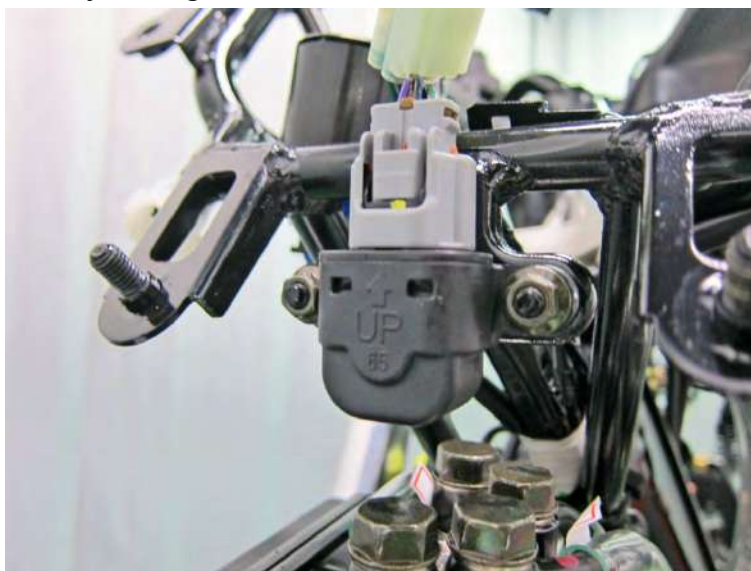

Place the tilt switch vertical as shown and the ignition switch “ON”. Measure the voltage as below.

Terminal	Standard
Violet/Red (+) ~ Green/Pink (-)	5 V (ECU voltage)
Black/Blue (+) ~ Green/Pink (-)	0.4 - 1.4 V less



Incline the tilt switch 65 ± 10 degrees to the left or right at the ignition switch “ON”. Measure the voltage as below.

Terminal	Standard
Violet/Red (+) ~ Green/Pink (-)	5 V (ECU voltage)
Black/Blue (+) ~ Green/Pink (-)	3.7 - 4.4 V

Note: Repeat this test, first turn the ignition switch to “OFF”, then turn the ignition switch to “ON”.



Disconnect the connector to remove the tilt switch.

Note: Install the tilt switch with its “up” mark facing up and tighten the two screws securely.

Self-Diagnosis

Note: No matter when the CELP illuminated while riding condition, should find out the cause of the problem as soon as possible.

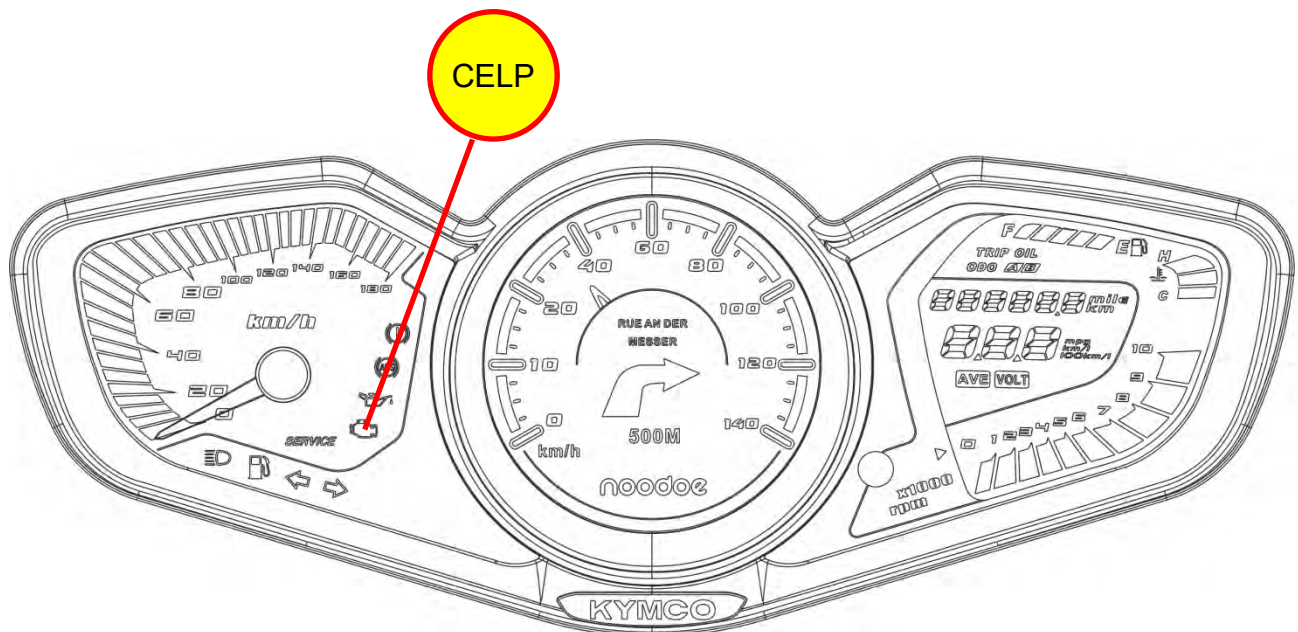

If the ECM connectors, or battery leads are disconnected the stored malfunction codes will be lost.

Fuel Injection Diagnostic Tool

OPERATION INSTRUCTIONS



Diagnostic tool Part Number: 3620A-LEB2-E00

This tool has been developed by KYMCO and for KYMCO vehicles only.

The tool software can be updated for new models with a computer via the USB cable.

Please refer to the specifications when serving this vehicle.

This tool does not have an internal battery. The power for the tool is provided by the vehicle when connected. The vehicle should have a fully charged battery when using the diagnostic tool.

The diagnostic tool is located under the seat.
Remove the protective rubber cover.



Use the Sub cord, OBD diagnostics connector (part number:36205-LGC6-E00) to connect between vehicle and diagnostic tool.



Plug in the tool to the ECU connector and turn on the ignition switch to send power to the tool.

Place the scooter on its main stand and put the side stand up prior to using the diagnostic tool.



□ The functions of the diagnostic tool include ECU version, model name, data analysis and reset.

ECU version: includes model name, ECU number, identifications number and software version.

Failure codes: DTC reading, DTC clearing, and troubleshooting.

Data analysis: For ECU's software inspection.

Reset: For the setting function adjustment.

ECU Version



The four functions will display when the tool is powered on. The model name will show ADG5 for the XCITING S 400.



Pressing the enter button on the ECU version will show model name, ECU number, identifications number and software version.

Press the down button (right) to return to the first page.

DTC (Diagnostic Trouble Code) INSPECTION PROCEDURE

Press the down button (right) to move the item selector down to the DTC Inspect item.



Pressing the enter button on the DTC Inspect item will bring up the options shown above.



Press the down button to select the load DTC option. Press the enter button on the Load DTC item to display the DTC options.



Move the selector to the Current option and press enter to display current DTC.



The diagnostic tool will display all current DTC.

Fuel Injection System Failure Code

NO.	Pcode
A1	P0030 O2 sensor heater malfunction
A2	P0031 O2 sensor heater Voltage Low
A3	P0032 Lambda sensor heater Voltage High
A4	P0105 MAP sensor malfunction
A5	P0107 MAP sensor Voltage Low
A6	P0108 MAP sensor Voltage High
A7	P0110 Intake air temperature sensor malfunction or Voltage High
A8	P0111 Intake air temperature circuit malfunction
A9	P0112 Intake air temperature sensor Voltage Low
D6	P0113 Intake air temperature sensor Voltage High
AA	P0114 Intake air temperature intermittent failure
AB	P0115 Engine Temperature Sensor malfunction or Voltage High
AC	P0117 Engine Temperature Sensor Voltage Low
AD	P0118 Engine Temperature Sensor Voltage High
AE	P0119 Engine Temperature intermittent failure
AF	P0120 Throttle Position Sensor malfunction or Voltage Low
B0	P0121 Throttle position sensor adaptation is out of range
B1	P0122 Throttle Position Sensor Voltage Low
B2	P0123 Throttle Position Sensor Voltage High
B3	P0124 Difference between the two last TPS acquisitions is out of range
B4	P0130 O2 sensor signal malfunction
B5	P0131 O2 sensor signal Voltage Low
B6	P0132 O2 sensor signal Voltage High
B7	P0200 Injection malfunction
B8	P0217 Engine over temperature condition
B9	P0219 CVT overspeed detected
BA	P0230 Fuel pump malfunction
BB	P0231 Fuel pump Voltage Low
BC	P0232 Fuel pump Voltage High
BD	P0260 Injection valve malfunction
BE	P0261 Injection valve Voltage Low
BF	P0262 Injection valve Voltage High
C0	P0335 Crankshaft sensor malfunction
C1	P0350 Ignition malfunction or Voltage Low
C2	P0351 Ignition Voltage High
C3	P0480 Fan Relay/Circuit malfunction
C4	P0505 ISAV idle speed actuator valve malfunction
C5	P0508 ISAV idle speed actuator valve Voltage Low
C6	P0509 ISAV idle speed actuator valve Voltage High

C7	P0562 Battery voltage VBK too Low
C8	P0563 Battery voltage VBK too High
C9	P0650 MIL Voltage High
CA	P0700 Engine overspeed detected
CB	P1110 Roll sensor Voltage High
CC	P1111 Roll sensor malfunction or Voltage Low
CD	P1410 AISV system break down
CE	P1630 Roll sensor circuit malfunction
CF	P2187 Lambda control too High
D0	P2188 Lambda control too Low
D1	B0099 Roll sensor Voltage High
D2	P263B MIL Voltage High
D3	P263A MIL Voltage Low
D4	P2300 Ignition malfunction or Voltage Low
D5	P2301 Ignition malfunction or Voltage High
D7	P0171 System over lean or over rich (Too Lean)
D8	P0172 System over lean or over rich (Too Rich)
D9	P0501 Vehicle Speed Sensor malfunction
DA	P0201 Injection valve malfunction
DB	P0412 Secondary air injection system malfunction
DC	P0603 ECU memory error
DD	P1205 MAP sensor malfunction
DE	P0500 Vehicle Speed Sensor malfunction
DF	P0511 ISC stepper motor malfunction
E0	P1505 ISC system malfunction
E1	P1521 VACS Valve circuit malfunction
F0	C0064 Roll sensor malfunction
F1	P0484 Fan Relay/Circuit Voltage High
F2	P0485 Fan Relay/Circuit Voltage Low
F3	P0560 Battery voltage VBK malfunction
F4	P0561 Battery voltage VBK malfunction
BE	P0264 Injection valve Voltage Low
BF	P0265 Injection valve Voltage High
D4	P2303 Ignition malfunction or Voltage Low
D5	P2304 Ignition malfunction or Voltage High
F5	P0642 Sensor Power Voltage Low
F6	P0643 Sensor Power Voltage High
F7	P0615 Starter Relay malfunction
F8	P0616 Starter Relay Voltage Low
F9	P0617 Starter Relay Voltage High

DTC Clear Procedure



Press the down button (right) to move the item selector down to the DTC Inspect item.



Pressing the enter button on the DTC Inspect item will bring up the options shown above.



Move the selector down to the Clear DTC option and press enter.



The diagnostic tool will show when the DTC in memory are cleared. Also, the DTC indicator light between the center and right buttons will be off.

 KYMCO Diagnostic Report				ADG5	
SF :		Customer :		Eng. No:	
Production Date :		Service Date :		Mileage :	
Reason of repair: <input type="checkbox"/> maintenance <input type="checkbox"/> breakdown					
Item		Date	Reference	Memo	
ECU Version	ECU No		39200-LKF5-E000		
	Hardware Ver		---		
	Software Ver				
	Calibration Ver		ADG5-BA		
	Model Name		KYMCO-ADG5		
DTC	Active				
	Occurred				
	History				
(Cool Engine) EngineStop	DTC Number				
	Throttle Position(%)		< 1.00%	Full Throttle: >93%	
	Throttle Position Voltage (V)		0.60±0.1 V	Full Throttle Voltage: >3.78V	
	Engine Temp.(°C)		Environ.temp ± 1.6 °C		
	Atom. Pressure(Kpa)		101.3 ± 3 kPa	When the height goes up at an elevation of 1000 meters, the atmosphere pressure goes down 12kpa.	
	Battery Voltage(V)		>12 V		
	O2 Sensor Voltage(V)		5±0.1 V		
	Roll Sensor State		ON(stand)		
	Spark plug Type		CR7E		
	CO Set		0	Original Setting: 0	
(Hot Engine) BeforeRepair	Engine speed (rpm)		1420 ± 100 rpm	Following data Engine Temp. > 80°C	
	Intake Pressure(Kpa)		32.0~40.0 kpa		
	Engine Temp.(°C)		°C		
	Fuel Inject Interval(ms)		2.25~3.25 ms		
	Ignition Timing (°)		8 ~ 12 BTDC		
	Battery Voltage(V)		>12 V		
	O2 Sensor Voltage(V)		0.05~0.90 V		
	Engine speed target (rpm)		1420 rpm		
	ISC Step (step)		90± 15		
	IDLE CO(%)		0.3~1.5%	Before muffler	
	CO Set		0	Suggestion Value:-5~5	
	(Hot Engine) AfterRepair	Engine speed (rpm)		1420 ± 100 rpm	Following data Engine Temp. > 80°C
Intake Pressure(Kpa)			32.0~40.0 kpa		
Engine Temp.(°C)			°C		
Fuel Inject Interval(ms)			2.25~3.25 ms		
Ignition Timing (°)			8 ~ 12 BTDC		
Battery Voltage(V)			>12 V		
O2 Sensor Voltage(V)			0.05~0.90 V		
Engine speed target (rpm)			1420 rpm		
ISC Step (step)			90± 15		
IDLE CO(%)			0.3~1.5%	Before muffler	
CO Set			0	Suggestion Value:-5~5	

CVT Continuously Variable Transmission

This chapter covers the location and servicing of the CVT components for the KYMCO XCITING 400i/XCITING S 400.

- Belt Case 7-2~7-11
- CVT Removal 7-12~7-28
- CVT Installation 7-29

GENERAL INSTRUCTIONS

- The drive pulley, clutch and driven pulley can be serviced with the engine installed.
- Avoid getting grease and oil on the drive belt and pulley faces. Remove any oil or grease from them to minimize the slipping of drive belt and drive pulley.

TROUBLESHOOTING

Engine starts but motorcycle won't move

- Worn drive belt
- Broken ramp plate
- Worn or damaged clutch lining
- Broken driven face spring

Engine stalls or motorcycle creeps

- Broken clutch weight spring

Lack of power

- Worn drive belt
- Weak driven face spring
- Worn weight roller
- Faulty driven face

Belt Case

SAFETY FIRST: Protective gloves and eyewear are recommended at this point.

Removal

Remove the following components -

- Seat
- Luggage Box
- Center Cover
- Rear Carrier
- Body Cover
- Front Cover
- Front Lower Cover
- Foot Skirt



Disconnect the drain hose from the air cleaner.



Remove 2 the air cleaner bolts with an 8 mm socket.



Remove 6 the belt case plastic cover bolts with an 8 mm socket.



XCITING 400i

Remove the belt case protector.



XCITING S 400



XCITING 400i



XCITING S 400



Remove 11 the belt case cover bolts with an 8 mm socket.



XCITING 400i



XCITING S 400

Remove 2 the air filter bolts with an 8 mm socket.

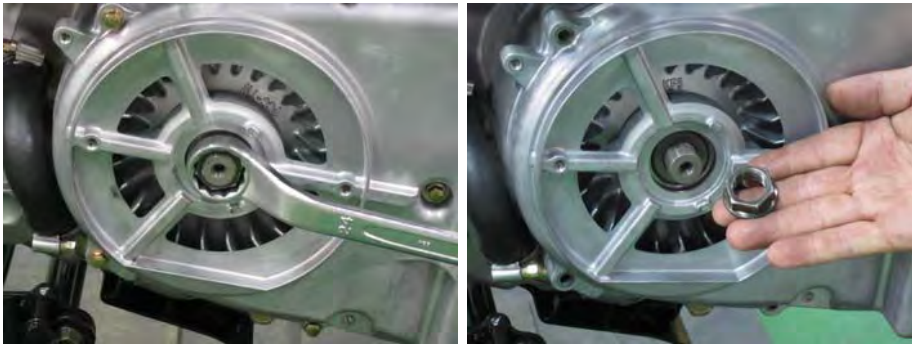

Remove the drive pulley nut with a 24mm socket.

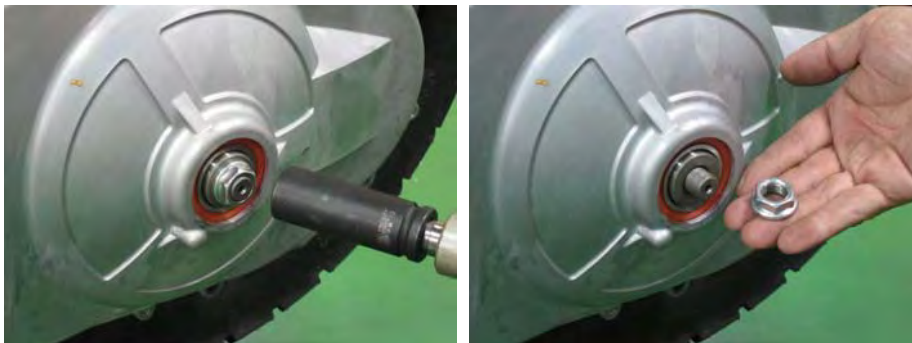

Remove the driven pulley nut with a 24mm socket.



XCITING 400i



XCITING S 400

Remove the belt case cover and gasket.



Remove the two dowel pins.

Inspection

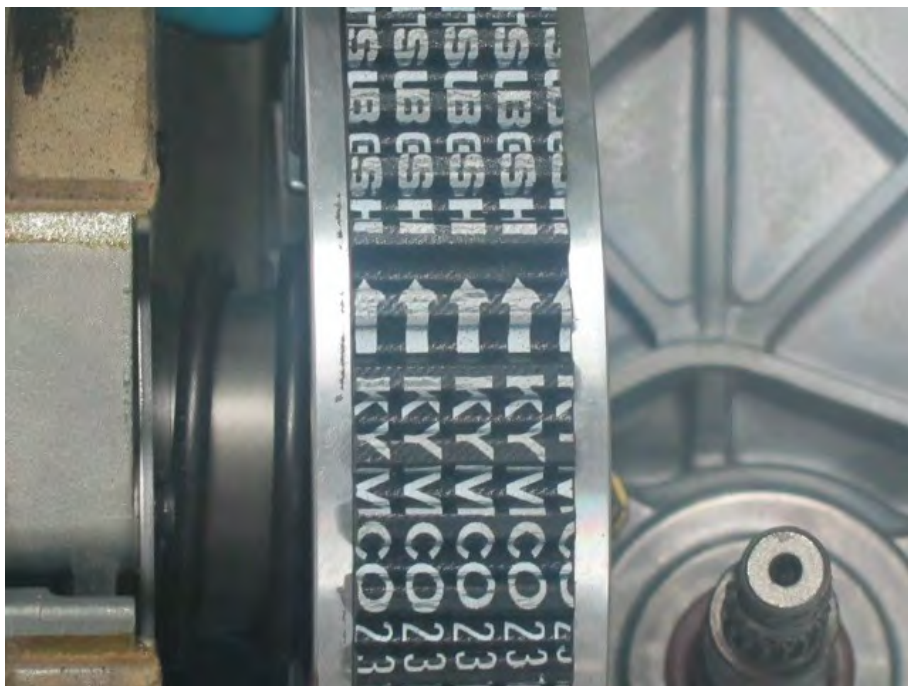

Inspect the drive belt for cracks or excessive wear.



Inspect the belt case bearing by turning it with a finger.
Replace the bearing if it is rough or noisy.

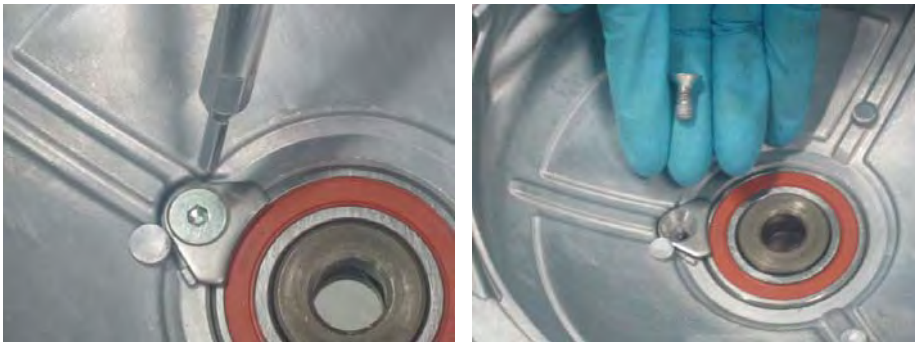

Remove the bearing fixed plate with a 5 mm Allen.



Remove two bearing collar.



Remove the bearing with a suitable bearing puller.

Tool number: A12E00093



Drive in a new bearing with a suitable bearing driver that has the same outside diameter as the bearing.

Tool number: A12E00014



Install two bearing collar.

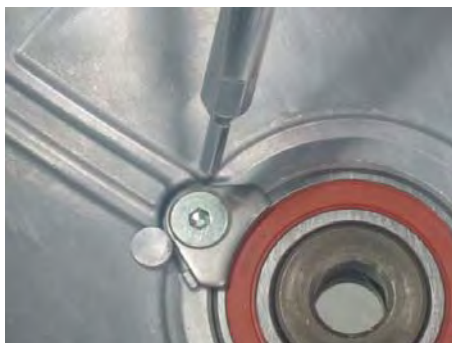

Install the bearing fixed plate with a 5 mm Allen

Installation



Install the two dowel pins into the belt case.



Install a new gasket with the belt case cover.



Install the driven pulley nut with a 24mm socket.



Install the drive pulley nut with a 24mm socket.

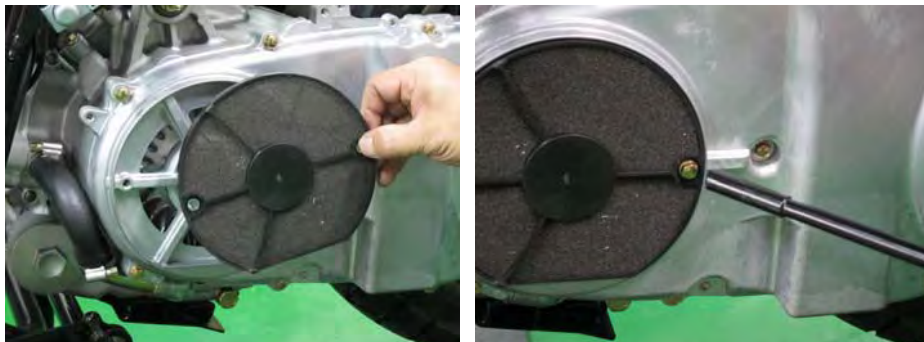

Install 2 the air filter bolts with an 8 mm socket.



Install the belt case cover bolts and tighten them securely with an 8 mm socket.



Install the belt case plastic cover.



Insert the plastic cover bolts and tighten them securely with an 8 mm socket.



Install 2 the air cleaner bolts with an 8 mm socket.



Fit the drain hose to the plastic belt case cover as shown.

CVT Removal

SAFETY FIRST: Protective gloves and eyewear are recommended at this point.

Remove the belt case. See the Belt Case topic for more information.

Pulleys and Belt



Remove the left face of the drive pulley.



Remove the outer clutch.

7. CVT Transmission > CVT Removal



XCITING 400i



XCITING S 400

Slide the driven pulley off of the shaft.



Remove the belt from the driven pulley.



Inspect the drive belt for cracks or excessive wear.

7. CVT Transmission > CVT Removal

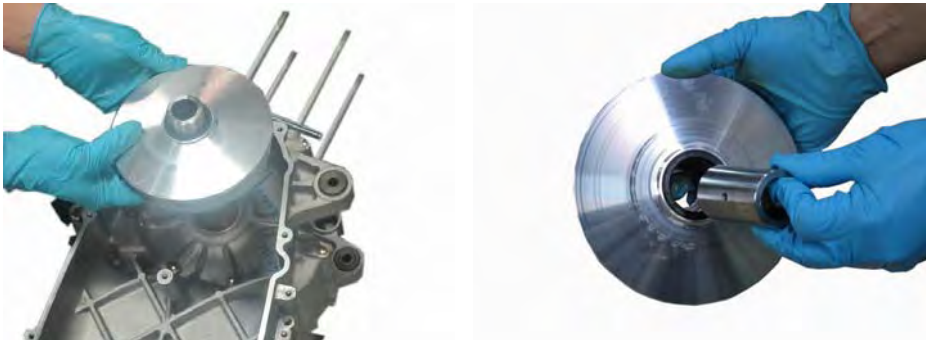

Remove the right (movable) face of the drive pulley from the crankshaft. Slide the bushing out of the movable drive face.

Drive Pulley Disassembly



Inspect the faces of the drive pulley. Clean away any grease from the faces. Inspect the oil seal of the drive pulley for broken or excessive wear.



XCITING 400i



XCITING S 400

Lift the ramp plate out of the back of the left drive pulley face.

7. CVT Transmission > CVT Removal



XCITING 400i



XCITING S 400

There are 6 weight rollers in the back of the right face of the drive pulley.



Remove the rollers and check them for excessive or uneven wear.
Measure the weight of the rollers.
Replace the weight rollers as needed.

Weight roller (Drive Pulley)

XCITING 400i: 17 ± 0.3 g

XCITING S 400: 11 ± 0.3 g

7. CVT Transmission > CVT Removal



Inspect the movable drive face and bushing for wear and damage. Replace the parts as needed.

Clutch Disassembly

Lift the clutch outer off of the centrifugal clutch.



Inspect the inside of the clutch outer for excessive wear and damage. Measure the inside diameter of the clutch outer and replace the part as needed.

7. CVT Transmission > CVT Removal



XCITING 400i

XCITING S 400

Inspect the clutch shoe lining thickness.
Replace the shoes if the wear is below the service limit.

Item	Standard (mm)	Service Limit (mm)
Clutch lining thickness	4.0	2.0

To disassemble the clutch and driven pulley set the clutch fitting tool to onto the clutch.

ITEM	TOOL NO.	DESCRIPTION
#46 NUT AND FITTING TOOL	A120E00098	CLUTCH DISASSEMBLY
SPRING COMPRESSOR	A120E00053	CLUTCHSPRING COMPRESSOR



Fit the clutch and fitting tool into the clutch spring compressor tool.

7. CVT Transmission > CVT Removal



Use the clutch spring compressor tool to compress the spring in the driven pulley assembly.

Loosen the clutch drive plate nut with the special socket that comes with the fitting tool.



Remove the clutch drive plate nut.

7. CVT Transmission > CVT Removal



Inspect the left side bearing by turning it with a finger. If the bearing is rough turning or noisy it should be replaced.

Remove the clutch spring compressor tool. Lift off the centrifugal clutch.



7. CVT Transmission > CVT Removal



Remove the collars and spring.



Measure the free length of the clutch spring. Replace the spring if the measurement fails to meet the service limit.

7. CVT Transmission > CVT Removal



Remove the three circlips from the clutch pivot pins with a small flat blade screwdriver.



Lift off the plate.

7. CVT Transmission > CVT Removal



Slide the clutch shoes off of the pivots on the drive plate.



Inspect the clutch shoe bumpers and replace them as needed.

Driven Pulley Disassembly

Remove the clutch as shown above.



Remove the four guide rollers with guide roller pins.



Separate the left and right faces of the driven pulley.

7. CVT Transmission > CVT Removal



Inspect the faces of the driven pulley. Clean away any grease from the faces where the belt rides.



Remove the seals from the left face of the driven pulley.

7. CVT Transmission > CVT Removal



Drive in the new seals with a suitable driver with the same outside diameter as the seal.



Remove the O-rings on the left face.

Clean the left face and roller pins with a high flash point solvent and compressed air.

NOTE: Always wear safety glasses when using compressed air and never point it directly at yourself or anyone else.

Bearing Replacement



Inspect the bearings in the right face of the driven pulley.



Remove the needle bearing with a suitable puller.



Remove the collar, snap ring, and bearing from the right face of the driven pulley.

Clean the right face with a high flash point solvent and compressed air.

NOTE: Always wear safety glasses when using compressed air and never point it directly at yourself or anyone else.



Drive in the new bearing so the sealed side face out towards the clutch. Install the snap ring into the groove. Install the collar and drive in the new needle bearing so that its markings face out. Drive in the bearings with a suitable driver with the same outside diameter as the bearing.



Lubricate the bearings in the right face of the driven pulley with grease

CVT Installation

SAFETY FIRST: Protective gloves and eyewear are recommended at this point.

Driven Pulley



Lubricate the bearings in the right face of the driven pulley with grease.



Drive in the new seals with a suitable driver with the same outside diameter as the seal.

Final Drive

This chapter covers the location and servicing of the final drive components for the KYMCO XCITING 400i / XCITING S 400.

- Final Reduction 8-2
- Final Drive Oil..... 8-3~8-8

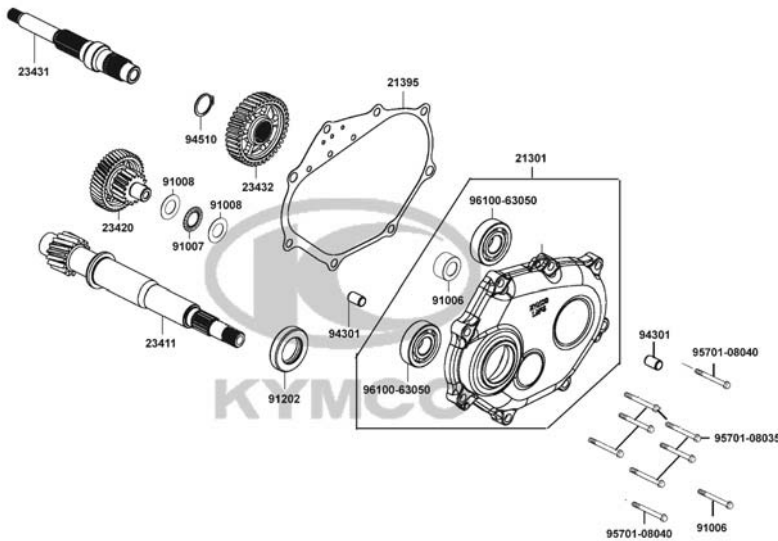

GENERAL INSTRUCTIONS

- The servicing operations of this section can be made with the engine installed.
- When replacing the drive shaft, use a special tool to hold the bearing inner race for this operation.

TROUBLESHOOTING

Engine starts but motorcycle won't move

- Damaged transmission
- Seized or burnt transmission

Abnormal noise

- Worn, seized or chipped gears
- Worn bearing

Oil leaks

- Oil level too high
- Worn or damaged oil seal

8. Final Drive

Final Reduction

SAFETY FIRST: Protective gloves and eyewear are recommended at this point.

Disassembly

Note: Do not remove the transmission case cover except for necessary part replacement. If the drive shaft is replaced, make sure to also replace the bearing and oil seal.



There are 8 transmission case cover bolts



8. Final Drive

Final Drive Oil

SAFETY FIRST: Protective gloves and eyewear are recommended at this point.

Place the scooter on level ground and up on its center stand.

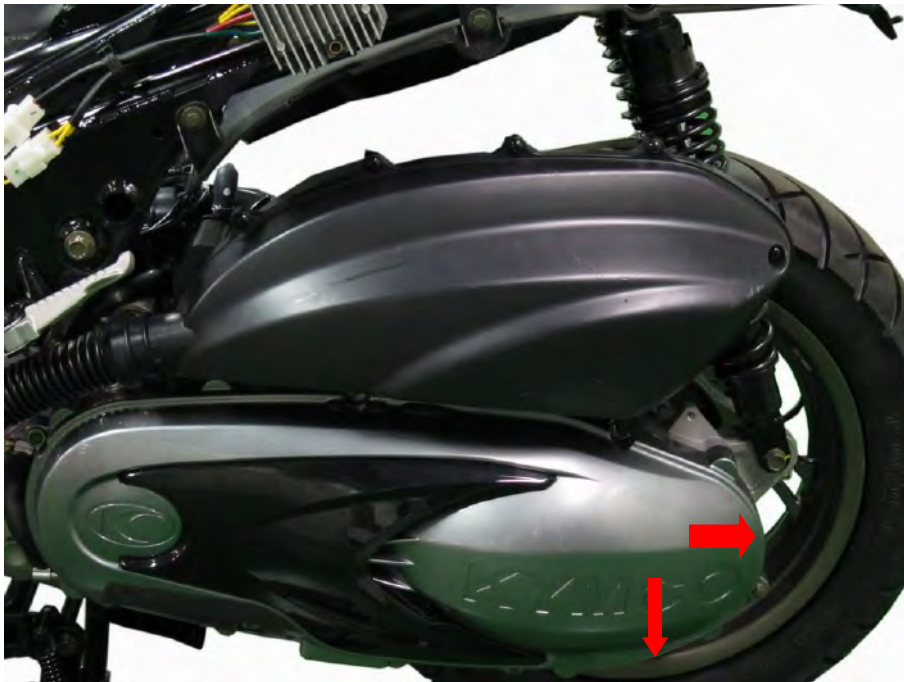

The oil drain bolt and oil filler bolt are located on the transmission.



XCITING S 400

Gear oil type:	SAE 90
Gear oil capacity:	
At disassembly	0.23 Liter
At change	0.20 Liter

8. Final Drive
Inspection

Place the vehicle on its center stand on level ground.



Remove the transmission oil level check bolt with a 12 mm socket. The oil level is correct when oil flows from the bolt hole. Install the oil level check bolt and tighten it to specification with a 12 mm socket.

Item	Qty	Thread size (mm)	Torqu	
			kgf-m	lb-ft
Final Drive oil check bolt	1	8	0.8 - 1.2	5.79 - 8.68

If the level is too high allow the oil to flow out of the check hole until the level is even with the bolt hole.

If the level is low add more of the same type and brand of oil as shown below. Inspect for leaks.

Draining

Place the vehicle on its center stand on level ground. Place a suitable oil drain pan under the transmission oil drain plug.



Place a suitable container under the drain plug to capture the final drive oil. Loosen the oil drain plug with a 12 mm socket. Remove the drain plug and slowly rotate the rear wheel to drain the transmission oil.



Inspect the drain plug and washer.

8. Final Drive

Install the oil drain plug and washer with a 12 mm socket.
Tighten to specification.

Item	Qty	Thread size (mm)	Torqu	
			kgf-m	lb-ft
Final Drive oil check bolt	1	8	0.8 - 1.2	5.79 - 8.68

8. Final Drive
Filling



Fill the final drive oil with a syringe until oil begins to flow from the level check bolt hole.

Gear oil type:	SAE 90
Gear oil capacity:	
At disassembly	0.23 Liter
At change	0.20 Liter

8. Final Drive

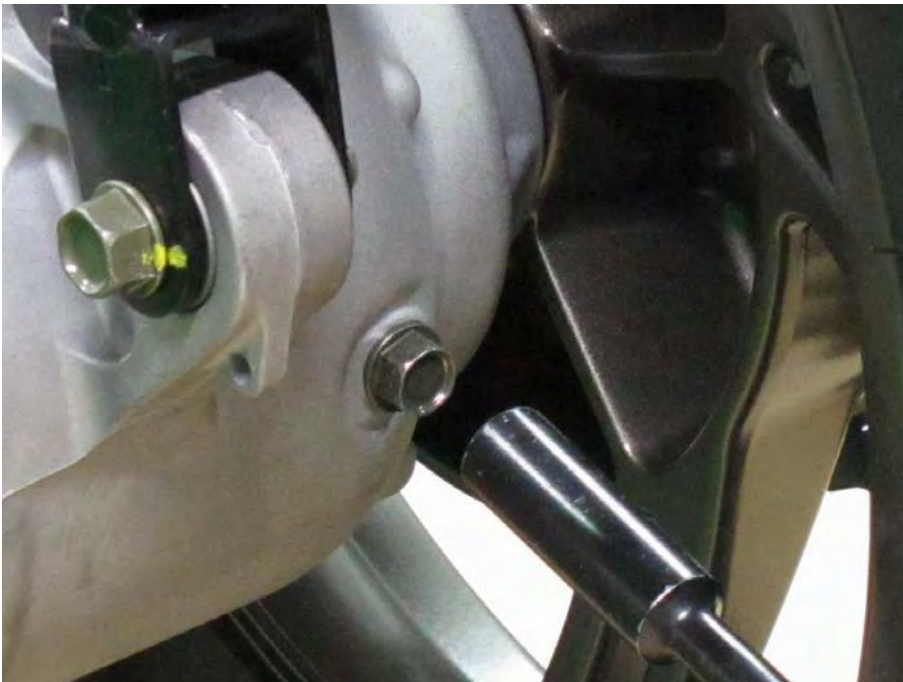

Thread in the final drive oil level check bolt.



Install the oil check plug and torque it to specification with a 12 mm socket.

Item	Qty	Thread size (mm)	Torque	
			kgf-m	lb-ft
Final drive oil check bolt	1	8	0.8 - 1.2	5.79 - 8.68

9. Electrical Systems

This chapter covers the location and servicing of the electrical systems for the KYMCO XCITING S 400 model.

General Instructions	9-1
Troubleshooting	9-3
Component Location	9-8
Fuses	9-11
ECU	9-12
Ignition System	9-14
Spark Plug	9-17
Charging System	9-20
Battery	9-22
Starting System	9-24
Relays	9-26
Switches	9-27
Luggage Box Light	9-28
Tilt Switch	9-30
Handlebar Switch	9-32
Side Stand Switch	9-34
Horn	9-35
Meter Instrument	9-36
USB Power Socket	9-37

GENERAL INSTRUCTIONS

- The battery can be charged and discharged repeatedly. If a discharged battery is not used for a long time, its service life will be shortened. Generally, the capacity of a battery will decrease after it is used for 2~3 years. A capacity-decreased battery will resume its voltage after it is recharged but its voltage decreases suddenly and then increases when a load is added.

- When a battery is overcharged, some symptoms can be found. If there is a short circuit inside the battery, no voltage is produced on the battery terminals. If the rectifier won't operate, the voltage will become too high and shorten the battery service life.
- If a battery is not used for a long time, it will discharge by itself and should be recharged every 3 months.
- A new battery filled with electrolyte will generate voltage within a certain time and it should be recharged when the capacity is insufficient. Recharging a new battery will prolong its service life.
- Inspect the charging system according to the sequence specified in the Troubleshooting.
- Do not disconnect and soon reconnect the power of any electrical equipment because the electronic parts in the regulator/rectifier will be damaged. Turn off the ignition switch before operation.
- It is not necessary to check the MF battery electrolyte or fill with distilled water.
- Check the load of the whole charging system.
- Do not quick charge the battery. Quick charging should only be done in an emergency.
- Remove the battery from the motorcycle for charging.
- When replacing the battery, do not use a traditional battery.
- When charging, check the voltage with an electric tester.

TROUBLESHOOTING

No power

- Dead battery
- Disconnected battery cable
- Fuse burned out
- Faulty ignition switch

Intermittent power

- Loose battery cable connection
- Loose charging system connection
- Loose connection or short circuit in the ignition system

Low power

- Weak battery
- Loose battery connection
- Charging system failure
- Faulty regulator/rectifier

Charging system failure

- Loose, broken or shorted wire or connector
- Faulty regulator/rectifier
- Faulty A.C. generator

Ignition System

GENERAL INSTRUCTIONS

- Some electrical components may be damaged if terminals or connectors are connected or disconnected while the ignition switch is “ON” and current is present.
- When servicing the ignition system, always follow the steps in the troubleshooting on page above.
- The ignition timing cannot be adjusted since the ignition control module is already adjusted in factory.
- The ignition control module or ECU maybe damaged if dropped or the connector is disconnected when the key is "ON", the excessive voltage may damage the ignition control module or ECU. Always turn off the ignition switch before servicing.
- A faulty ignition system is often related to poor connections. Check those connections before proceeding.
- Make sure the battery is adequately charged. Using the starter motor with weak battery results in a slower engine cranking speed as well as no spark at the spark plug.
- Use a spark plug of the correct heat range. Using spark plug with an incorrect heat range can damage the engine.

TROUBLESHOOTING

No peak voltage

- Short circuit in engine stop switch or ignition switch wire.
- Faulty engine stop switch or ignition switch.
- Loose or poorly connected ignition control module connectors.
- Open circuit or poor connection in ground wire of the ignition control module.
- Faulty crank position sensor.
- Faulty ignition control module.

Peak voltage is normal, but no spark jumps at the plug

- Faulty spark plug or leaking ignition coil secondary current.
- Faulty ignition coil.

Starting System

GENERAL INSTRUCTIONS

- The removal of starter motor can be accomplished with the engine installed.
- After the starter clutch is installed, be sure to add the engine oil and coolant and then bleed air from the cooling system.

TROUBLESHOOTING

Starter motor will not turn

- Fuse burned out
- Weak battery
- Faulty ignition switch
- Faulty starter clutch or gear
- Faulty front or rear stop switch
- Faulty starter relay
- Poorly connected, broken or shorted wire
- Faulty starter motor

Lack of power

- Weak battery
- Loosed wire or connection
- Foreign matter stuck in starter motor

Starter motor rotates but engine does not start

- Faulty starter pinion
- Starter motor rotates in reverse
- Weak battery

Lights, Switches, AND Fuel Pump

GENERAL INSTRUCTIONS

- Note the following when replacing the halogen headlight bulb
 1. Wear clean gloves while replacing the bulb. Do not put finger prints on the headlight bulb, as they may create hot spots on the bulb and cause it to fail.
 2. If you touch the bulb with your bare hands, clean it with a cloth moistened with alcohol to prevent its early failure.
 3. Be sure to install the dust cover after replacing the bulb.

- Check the battery condition before performing any inspection that requires proper battery voltage.
- A continuity test can be made with the switches installed on the scooter.
- Route the wires and cables properly after servicing each component.

TROUBLESHOOTING

Lights do not come on when ignition switch is “ON”

- Burned bulb
- Faulty switch
- Poorly connected, broken or shorted wire

Temperature gauge does not register correctly

- Faulty temperature gauge
- Faulty thermosensor
- Broken or shorted wire between the temperature gauge and thermosensor

Fuel gauge does not work or shows wrong figures

- Faulty fuel gauge
- Faulty fuel unit
- Poorly connected wire between fuel gauge and fuel unit
- Fuse burned out

Component Location

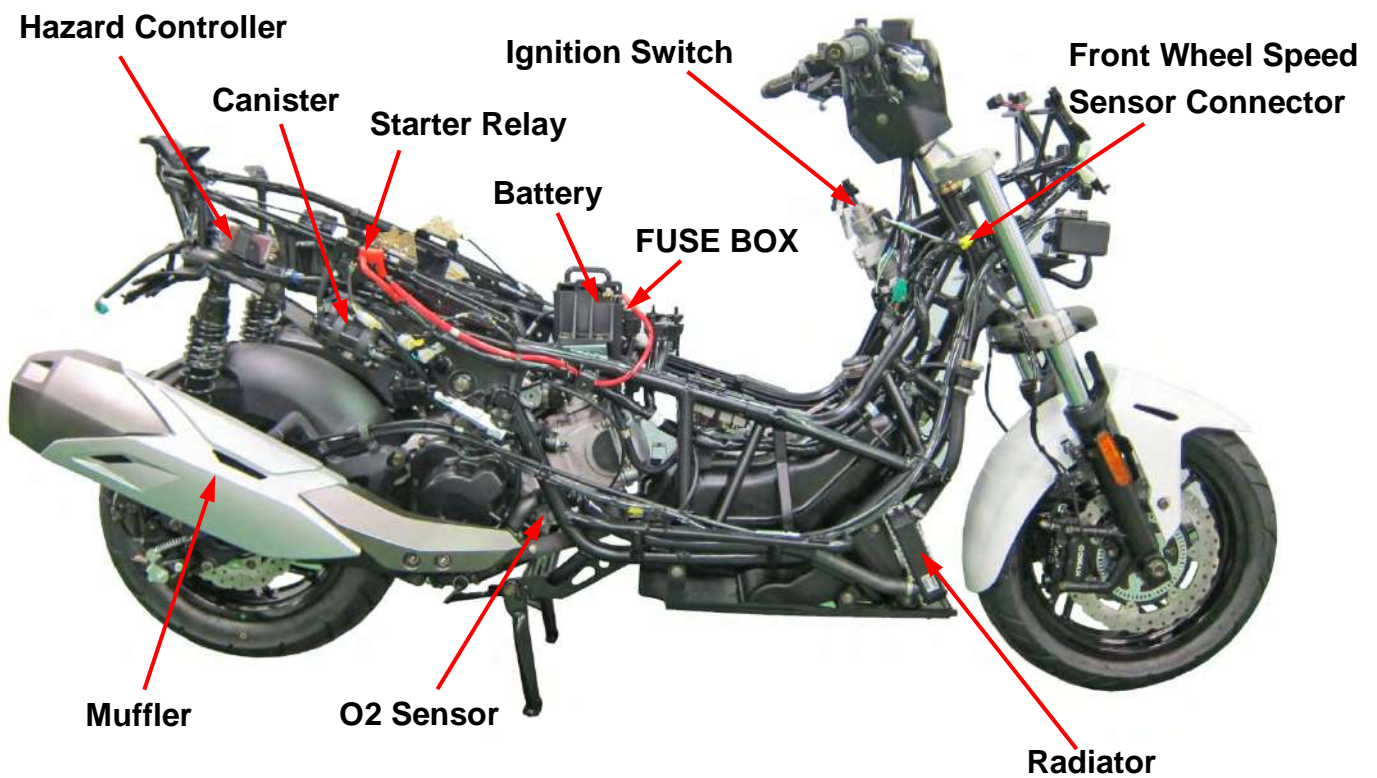
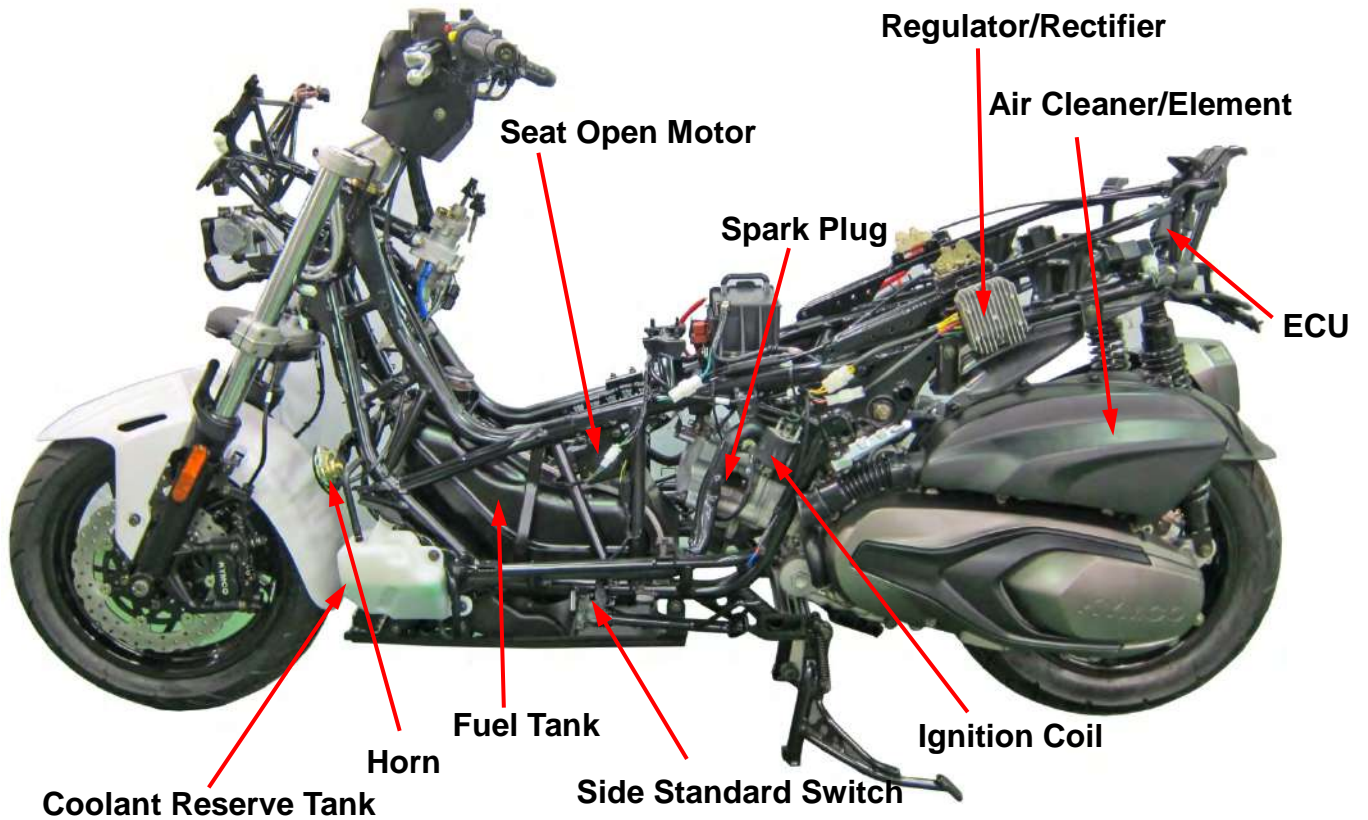

Component Location

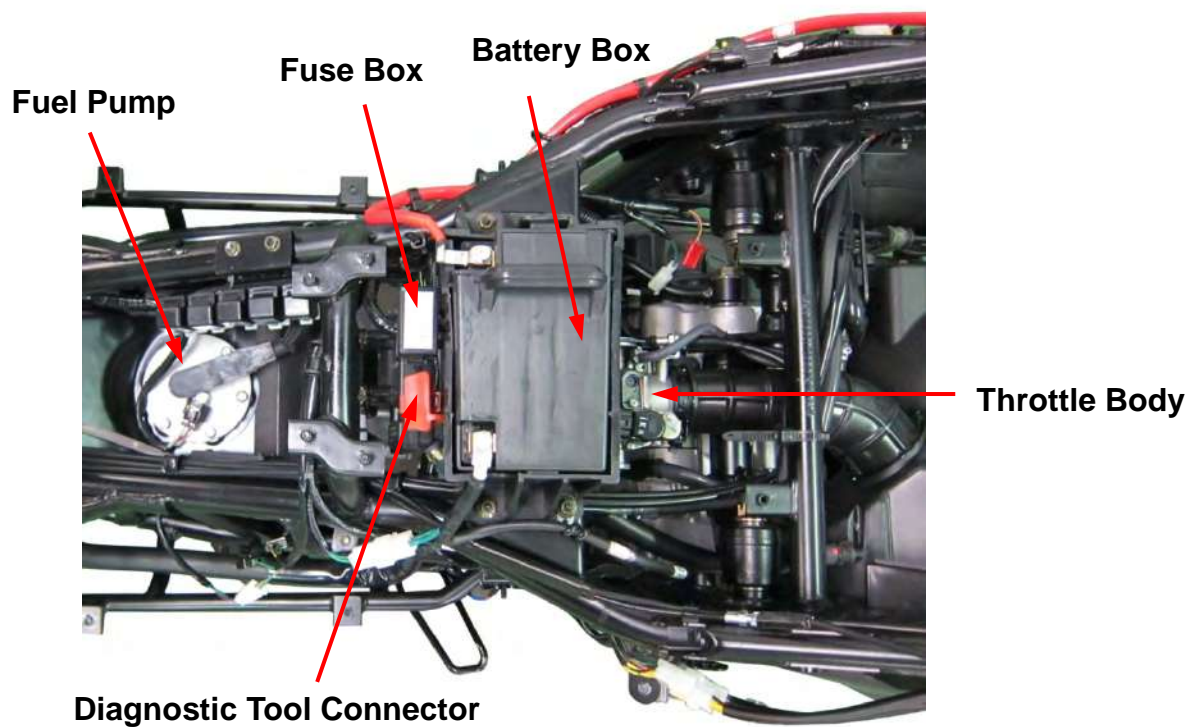
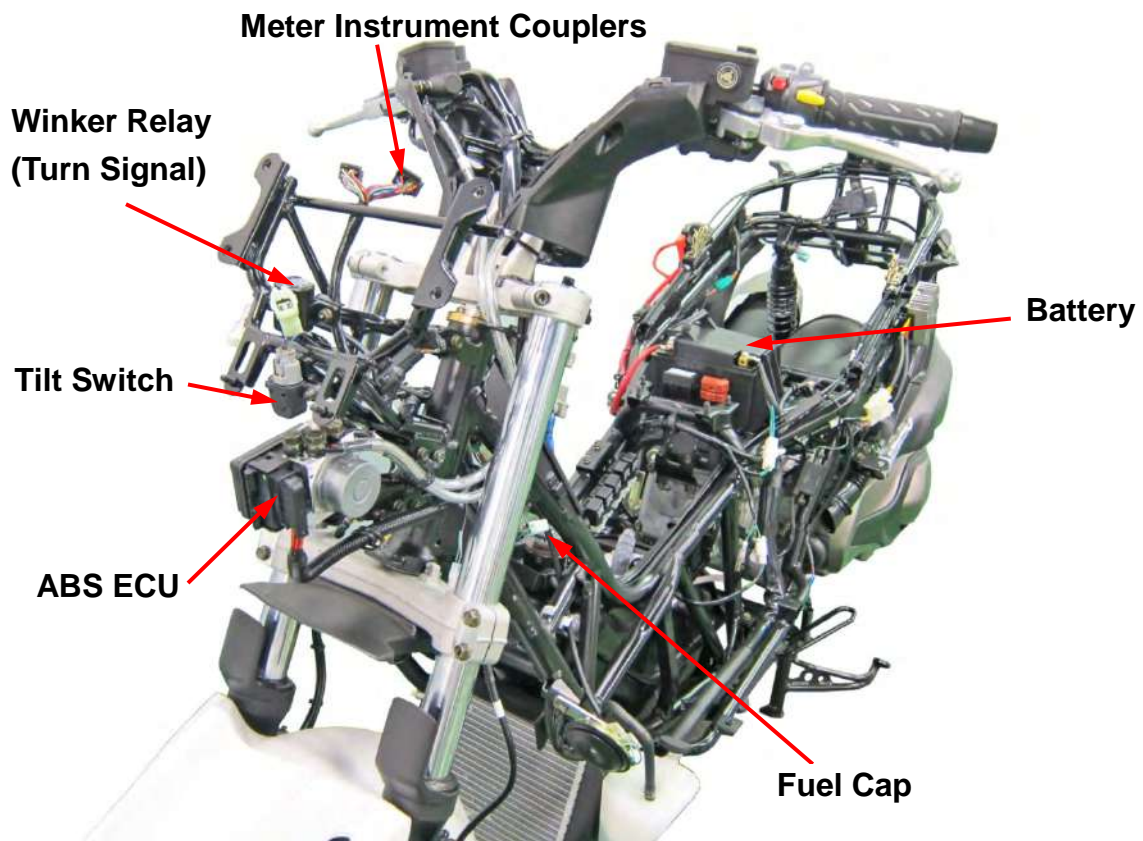

Component Location

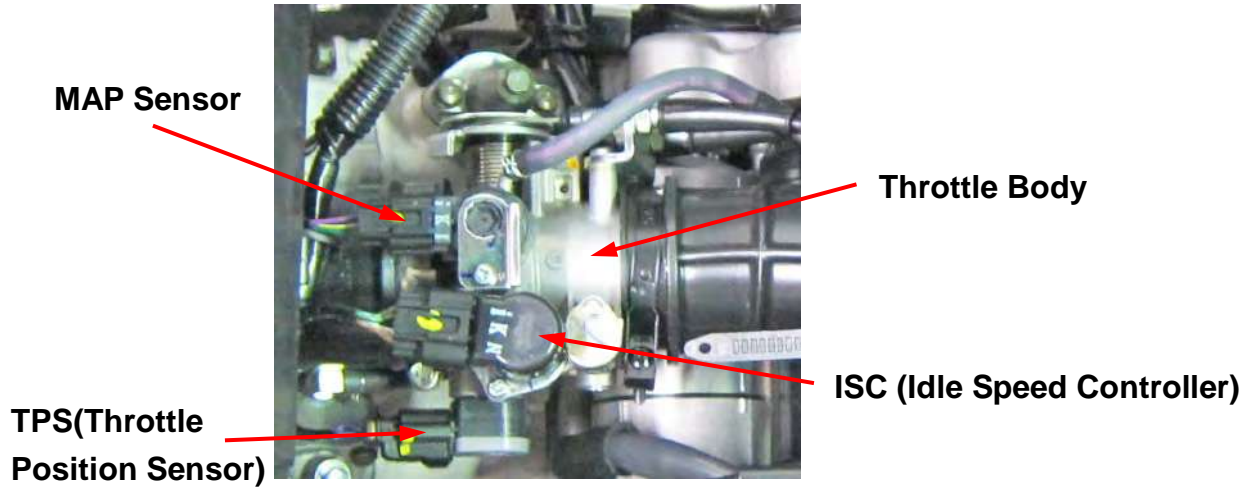

Seat Open Motor Relay/ Starter Relay/ Fuel Pump Relay/ ECU Relay/ Fan Relay
(The location refer to the wiring diagram wire color)

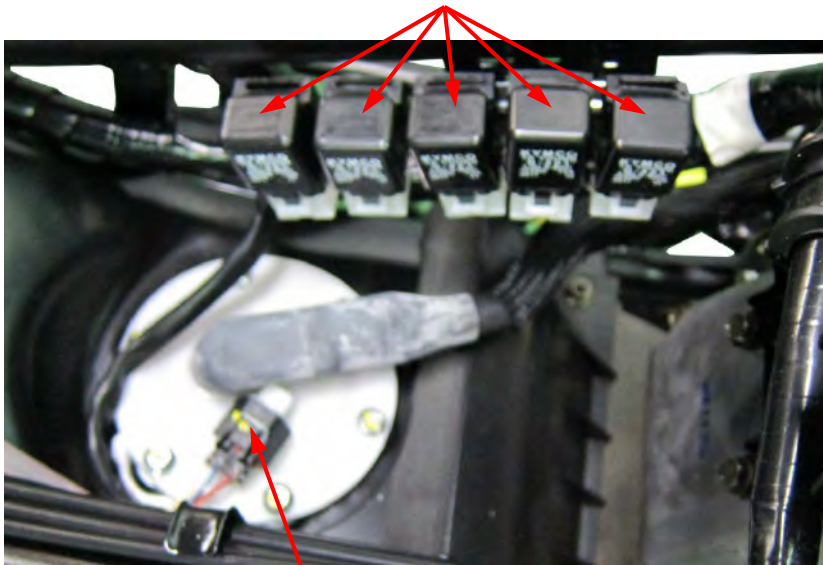

Fuel Pump

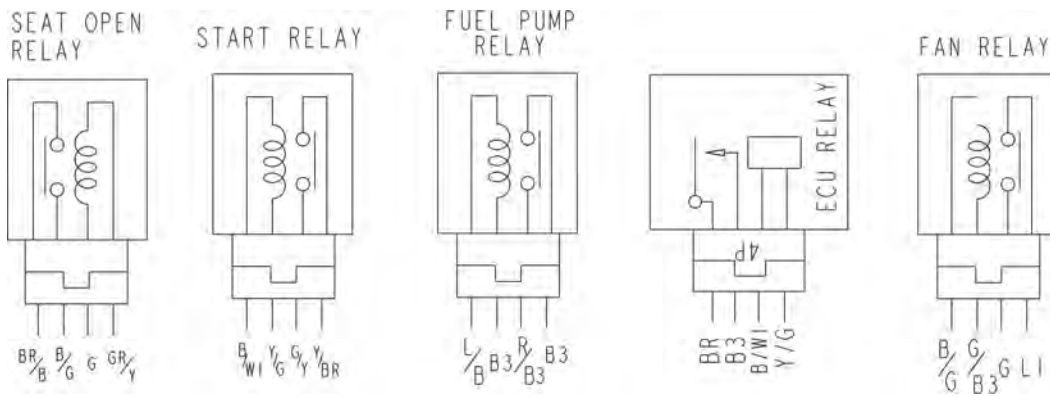

Fuses

Fuse Box

The fuse box is located on top of the battery. Open the covers to access the fuses.



FUSE ASS'Y

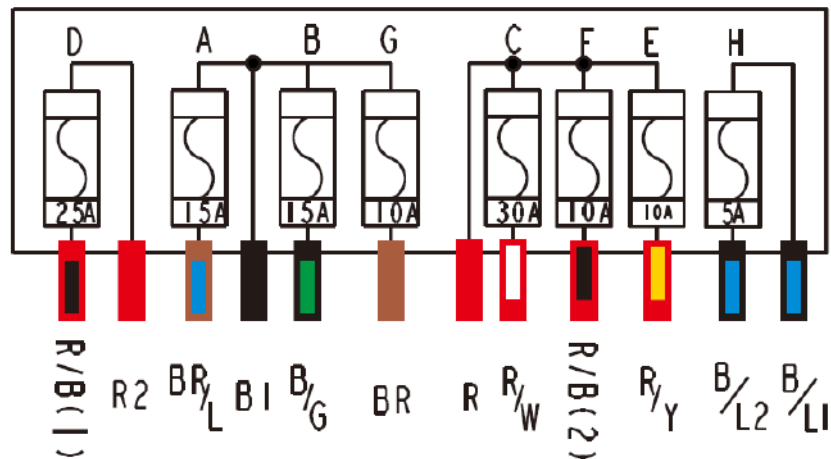

- FUSE A: 15A (Winker, FR/RR Stop Horn, Meter, Starter, Position, Phone)
- FUSE B: 15A (Ignition, IGN Coil, Fuel Pump, Angle Detector Sensor, Fan Motor)
- FUSE C: 30A (Charging)
- FUSE D: 25A (ABS Motor)
- FUSE E: 15A (Head Light, Clock)
- FUSE F: 10A (ABS ECU)
- FUSE G: 10A (ECU Relay, Fuel Injector)
- FUSE H: 5A (Hazard, Magnet Valve Controller)

ECU

Remove the luggage box, body cover and external covers. See the external topic for more information.

Note: The ECU could be damaged if dropped or the connector is disconnected when the key is on. The excessive voltage may damage the ECU. Always turn off the ignition switch before servicing.

Press the tab to disconnect the ECU harness.



Remove the nuts and bracket to remove the ECU.



Inspection

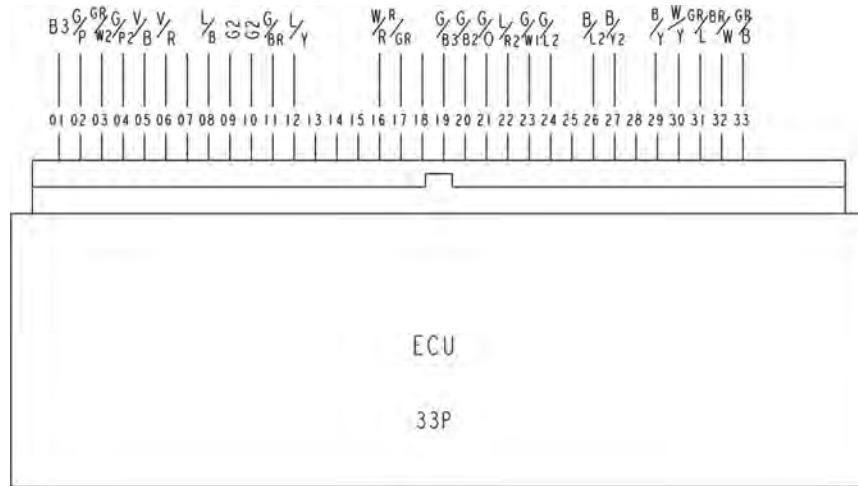

Disconnect and remove the ECU from the frame.

Check for continuity between pin 9 and 10 of the ECU side connector.

There should be continuity at all times.

Check for continuity between each pins 2, 4 and 23 of the ECU side connector.

There should be continuity at all times.

Check for continuity between pin 24 and 10 of the ECU side connector.

PIN NO.	NAME	FUNCTION	PIN NO.	NAME	FUNCTION
01	IGP	IGNITION POWER	19	FAN	FAN RELAY
02	LGI	LOGIC GROUND 1	20	ISCBP	IDEL SPEED CONTROL B
03	HEGO	HEGO SENSOR	21	ISCAP	IDEL SPEED CONTROL A
04	SG	SENSOR GROUND	22	MIL	MULTI INDICATOR LAMP
05	TH	THROTTLE POSITION SENSOR	23	CRK-M	CRANK PULSE SENSOR GND
06	VCC	SENSOR POWER OUTPUT(+5V)	24	TW	WATER TEMP. SENSOR
07	-	-	25	-	-
08	FLPR	FUEL PUMP RELAY	26	ROLL	ROLL SENSOR
09	PG1	POWER GROUND 1	27	PM	MANIFOLD PRESSURE SENSOR
10	PG2	POWER GROUND 2	28	SOL	-
11	IG	IGNITION COIL	29	NE	METER
12	CRK-P	CRANK PULSE SENSOR	30	K-LINE	DIAGNOSTIC TOOL
13	-	-	31	ISCBN	IDEL SPEED CONTROL / B
14	TA	AIR TEMP. SENSOR	32	ISCAN	IDLE SPEED CONTROL / A
15	TEST	-	33	HEGO HT	HEGO SENSOR HTATER
16	INJ	INJECTION			
17	VSP	VEHICLE SPEED SENSOR			
18	-	-			

Ignition System

Ignition System

The ignition timing is set at the factory and is not adjustable. Perform the following checks. Before performing any tests make sure the electrical connections are not loose or corroded.

Ignition Coil

Remove the connectors.

Remove the two ignition coil mounting bolts and remove the ignition coil.

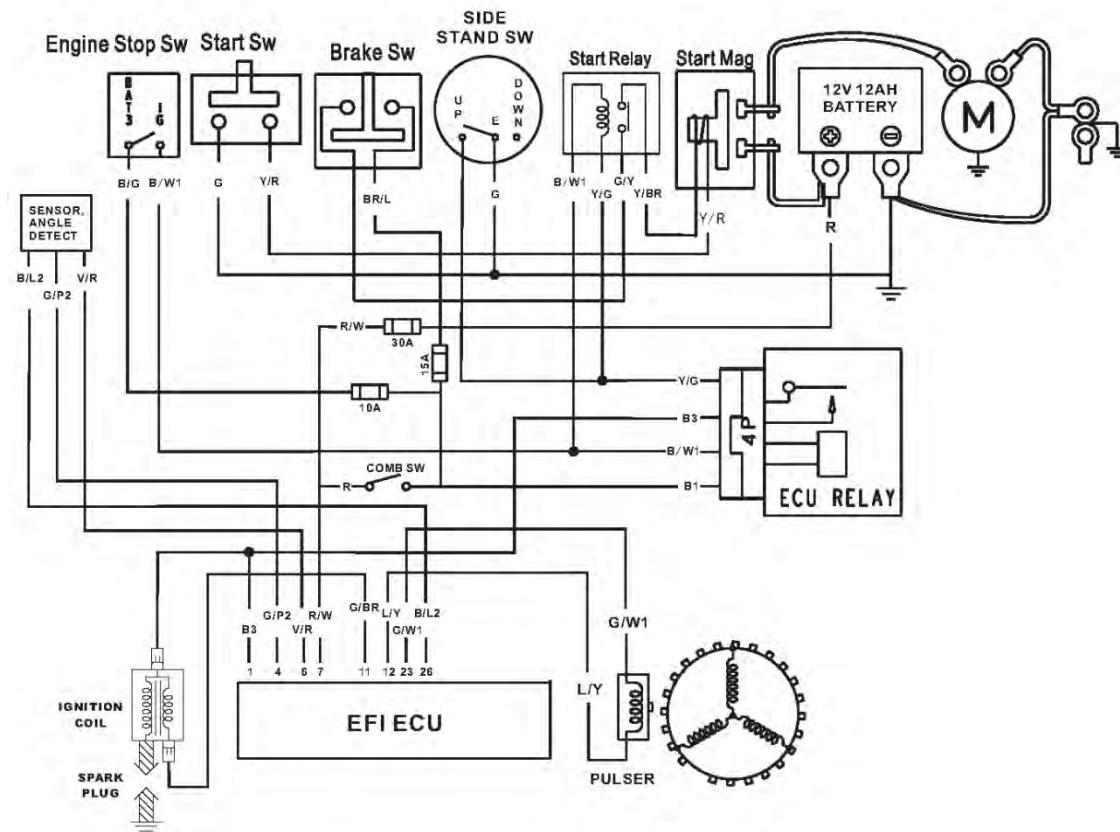

Ignition Coil Resistance**Primary**

Set the multimeter to read ohms of resistance (Ω).

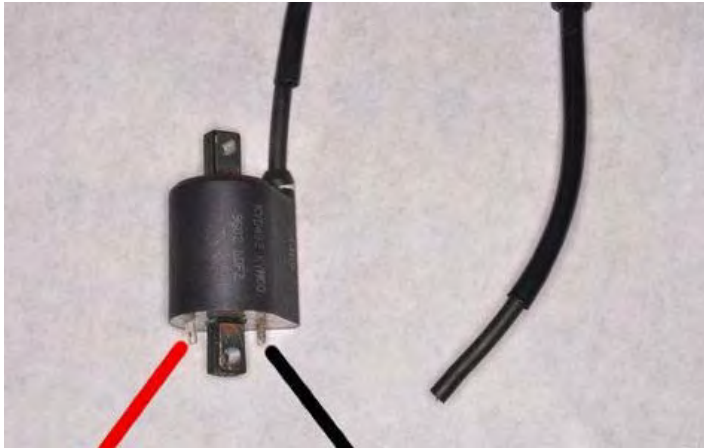

Touch the positive and negative meter leads to the ignition coil terminals as shown. Measure the resistance.

Ignition Coil Primary Resistance	3.57 - 4.83 Ω
----------------------------------	----------------------

Secondary With Plug Cap

Check the secondary resistance between the ignition coil terminal and the spark plug cap. Touch the negative meter lead to the terminal and the positive meter lead to the spark plug cap as shown.

Secondary Resistance With Plug Cap	15 - 19 Ω
------------------------------------	------------------

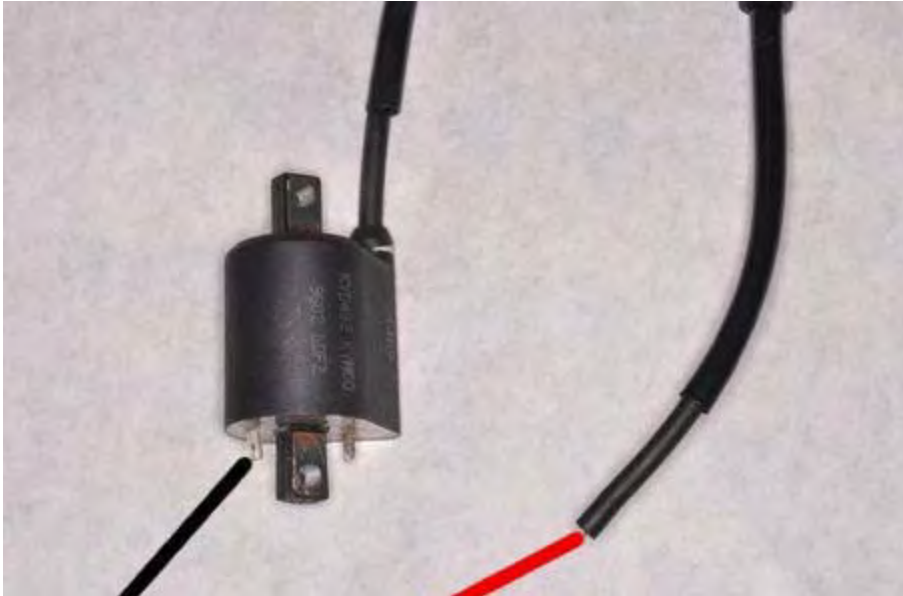
Secondary Without Plug Cap

Check the secondary resistance between the ignition coil terminal and the spark plug wire without the cap. Touch the negative meter lead to the terminal and the positive meter lead to the spark plug wire as shown.

Secondary Resistance Without Plug Cap	7.2 – 10.8k Ω
---------------------------------------	-------------------------

Spark Plug

Turn the ignition switch to ON, lift the side stand, hold in one of the brake levers, and push the engine start button. The plug should spark.

Caution: Do not touch the spark plug or spark plug wire while cranking or running the engine as this can result in a severe shock.

Remove the spark plug with a spark plug with a 5/8 in socket.



Spark plug	NGKCR7E
------------	---------

Check the spark plug to see if it is the correct type and gapped properly. If the spark plug is black and fouled, replace it.

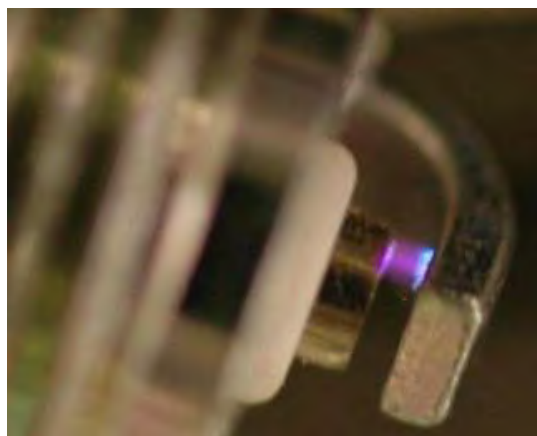

If the spark plug center electrode or side electrode are corroded or damaged, or if the insulator is cracked, replace the plug.

Measure the gap with a wire-type thickness gauge.
If the gap is incorrect, replace the spark plug.

Always check the gap of the spark plug before installation. Inspect the color of the porcelain nose of the spark plug. The color of the spark plug can indicate how the mixture is burning. A white colored plug shows a lean mixture, where a dark plug shows a rich mixture. Do not hesitate to replace a spark plug. Always replace a spark plug if any part of it is damaged.

Spark plug gap	0.7 ~0.8 mm
----------------	-------------

Do not over tighten the spark plug. The cylinder head is made out of soft metal, and it can be easily damaged.

Item	Torque
Spark plug	0.8~1.2 kgf-m

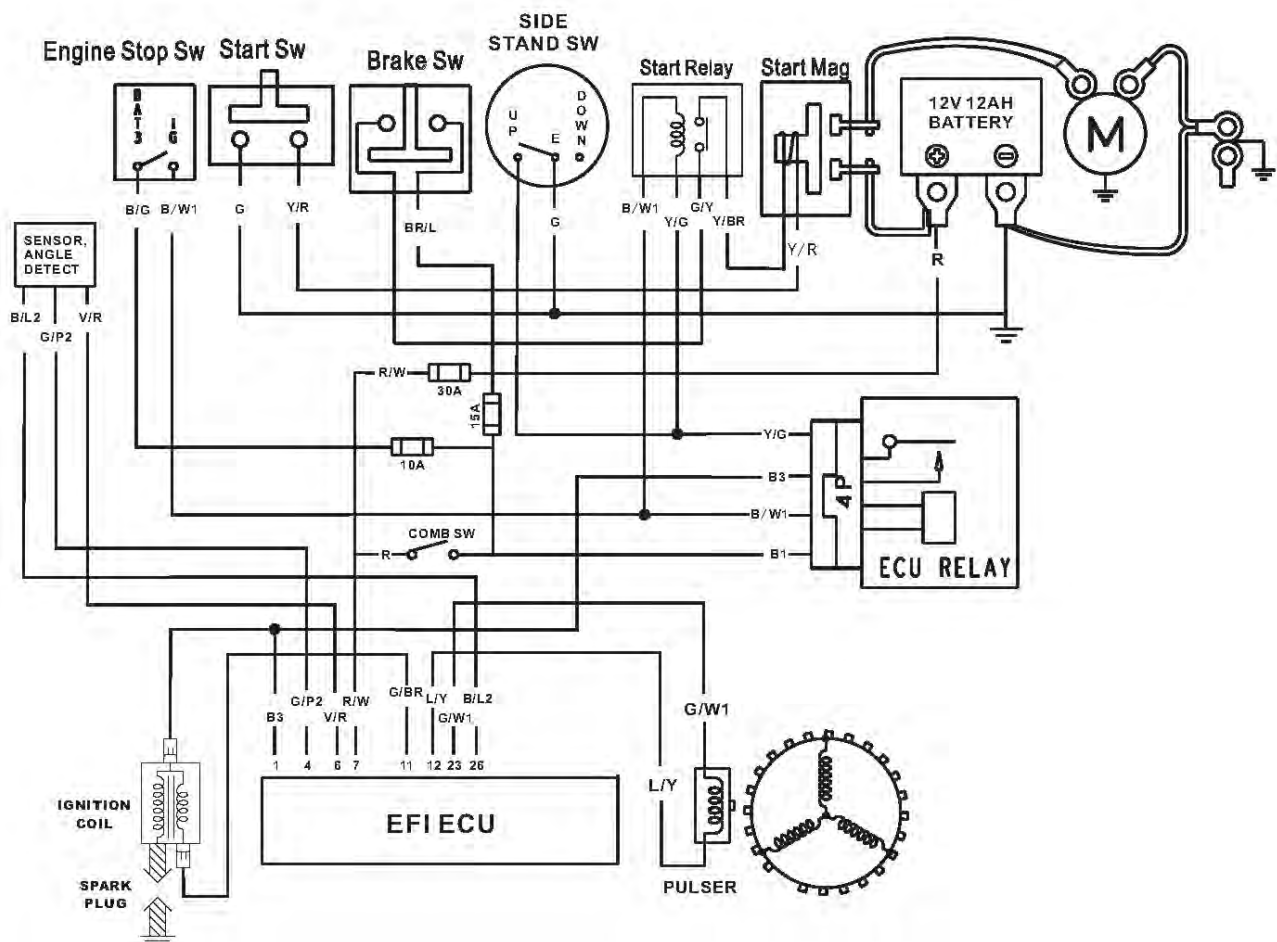

AC Generator Inspection

Crank Position Sensor Inspection

Note: This test is performed with the stator installed in the engine.

Disconnect the crank position sensor wire coupler. Measure the resistance between L/Y and G/GR wire terminals.



Resistance	
L/Y – G/GR	115 Ω \pm 15 Ω

Charging System

To replace the stator/charging coil see the A.C. Generator and Starter clutch topic.

Charging Voltage Inspection

Remove the battery cover. See the Battery topic for more information.

Note: The battery should be fully charged prior to making charging system checks.

Start the engine and warm it up to the operating temperature; stop the engine. Connect the multimeter between the positive (+) and negative (-) terminals of the battery. To prevent short, make absolutely certain which are the positive (+) and negative (-) terminals or cable.

CHARGING SYSTEM

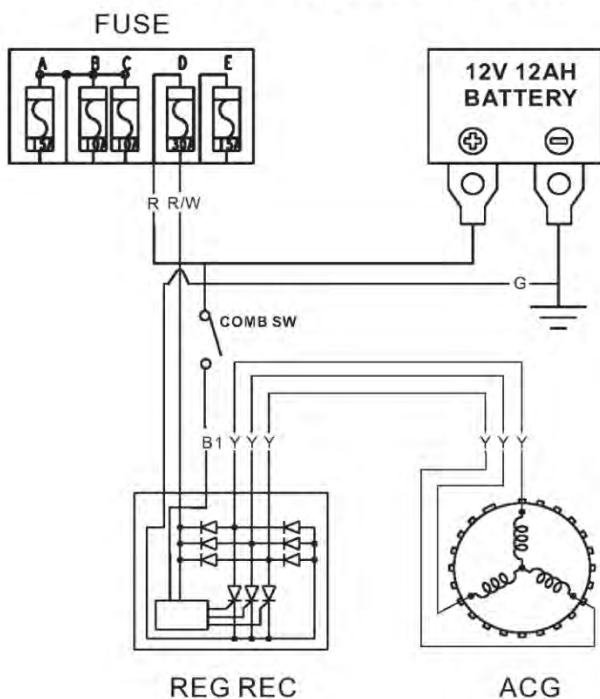

Turn the ignition switch on and turned to the high beam position, restart the engine. Measure the voltage on the multimeter when the engine runs at 5000 rpm.

Battery charging voltage@ 5000 rpm	14 ~ 15V
---	----------

Charging Coil Wire

Disconnect the generator 3-pin connector. Check the connectors for loose contacts or corroded terminals.



Measure the resistance between each Yellow wire terminals.

Check for continuity between each yellow wire terminal regulator/rectifier side and ground. There should be no continuity.

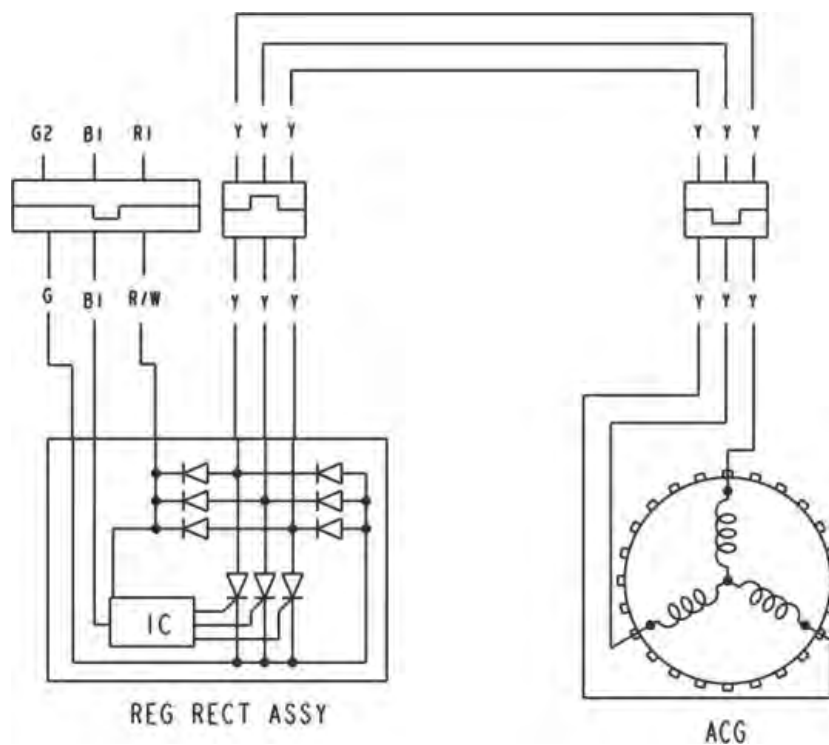

Battery

SAFETY FIRST: Protective gloves and eyewear are recommended at this point.

Warning: The battery electrolyte (sulfuric acid) is poisonous and may seriously damage the skin and eyes. Avoid contact with skin, eyes, or clothing. In case of contact, flush with water and get prompt medical attention.

Removal

The battery is located in the front of the vehicle.

Remove the windscreen and meter cover. See the external topic for more information.

Remove the battery cover screws and remove the battery cover.

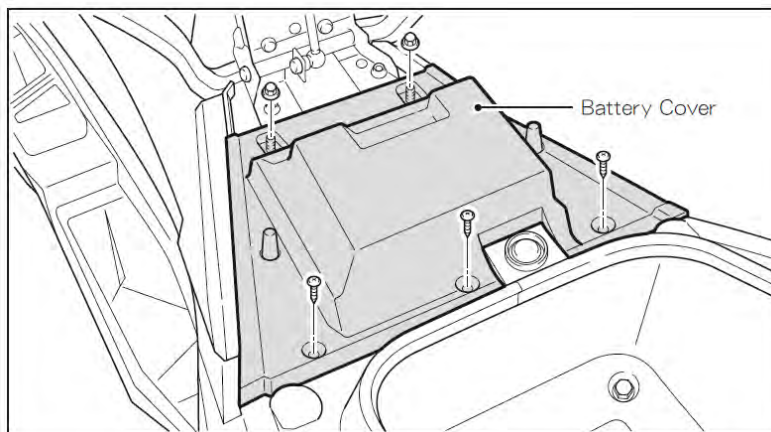

Remove the negative battery cable bolt and free the negative cable from the battery first. Then remove the positive battery cable bolt and lift the battery out of the battery tray.

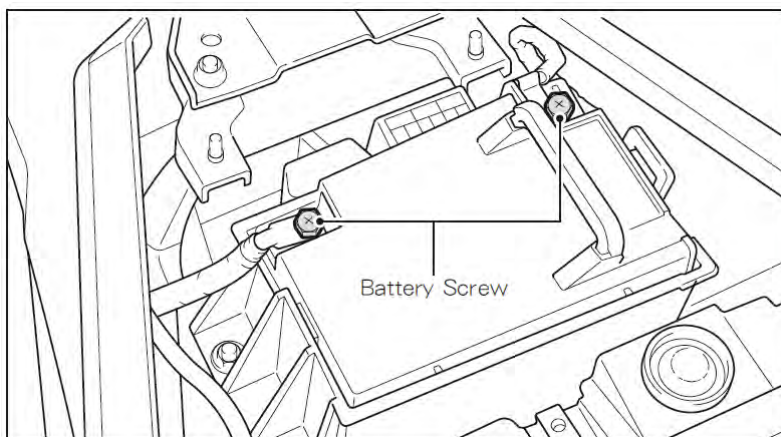

Battery Testing

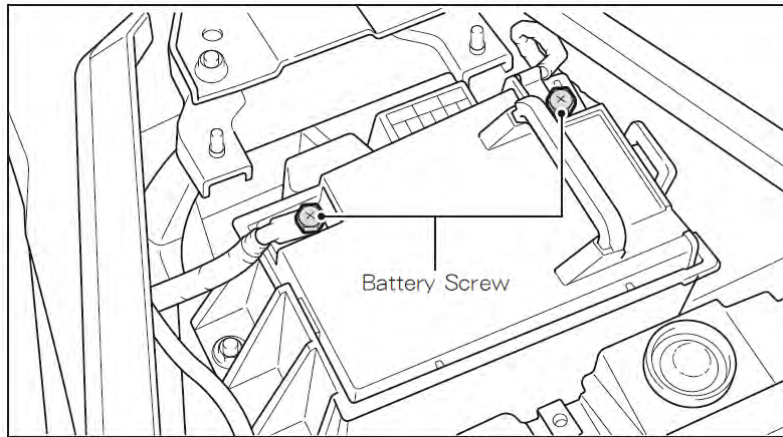

Check the battery voltage with a multi-meter. Place the positive probe onto the positive battery terminal and the negative probe to the negative battery terminal. If the battery reads under 12.3 V it is undercharged.

Battery Voltage (20°C/68°F)	
Fully Charged	13.0 - 13.2 V

Battery Charging

Charge the battery with a motorcycle specific battery charger at the specified rate. Connect the charger leads to their appropriate battery terminals. Keep open flames away from a charging battery.

Standard Charge	
1.1 Amps	5 - 10 Hours

Note: For battery charging, do not exceed the charging current and time specified on the battery. Using excessive current or extending the charging time may damage the battery.

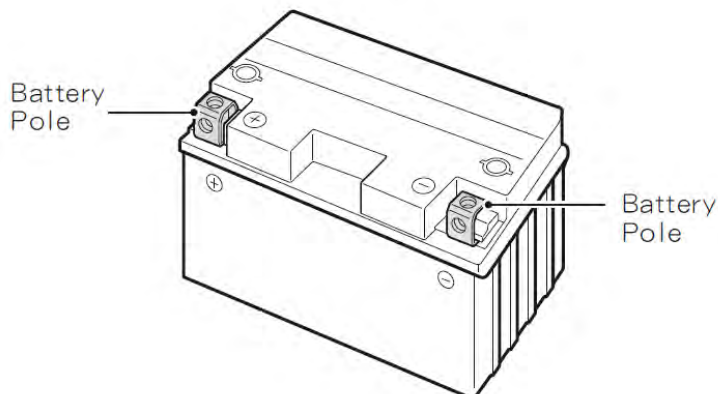

Starting System

Starter Relay Inspection

Disconnect the starter relay wire connector.
And remove the starter relay.

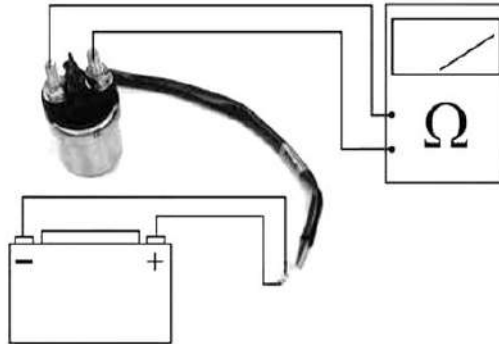

Check for continuity between the yellow/red wire and green/yellow wire. There should be continuity when the starter button is depressed. If there is no continuity, check the starter button for continuity and inspect the wire.

Connect the electric meter to the starter relay terminals that connect to the battery positive cable and the starter motor cable. Connect a fully charged battery across the starter relay yellow/red and green/yellow wire terminals.

Check for continuity between the starter relay large terminals. The relay is normal if there is continuity and hear sounds.

Warning: Do not apply the battery voltage jump for more than five seconds or the relay may be damaged.

Do not over tight the nuts or the relay may be damaged.

Starter Motor

Pull back the rubber starter motor lead cover and remove the nut. Remove two starter motor mounting bolts and remove the starter motor.

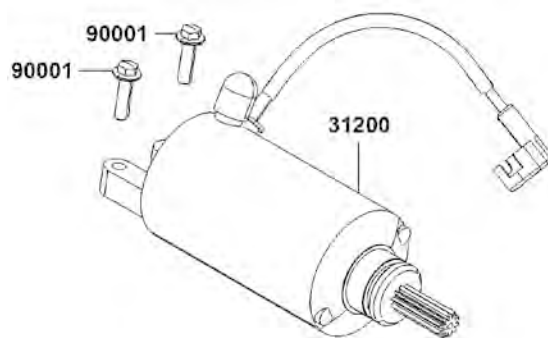

Inspect the starter motor O-ring and replace it as needed.

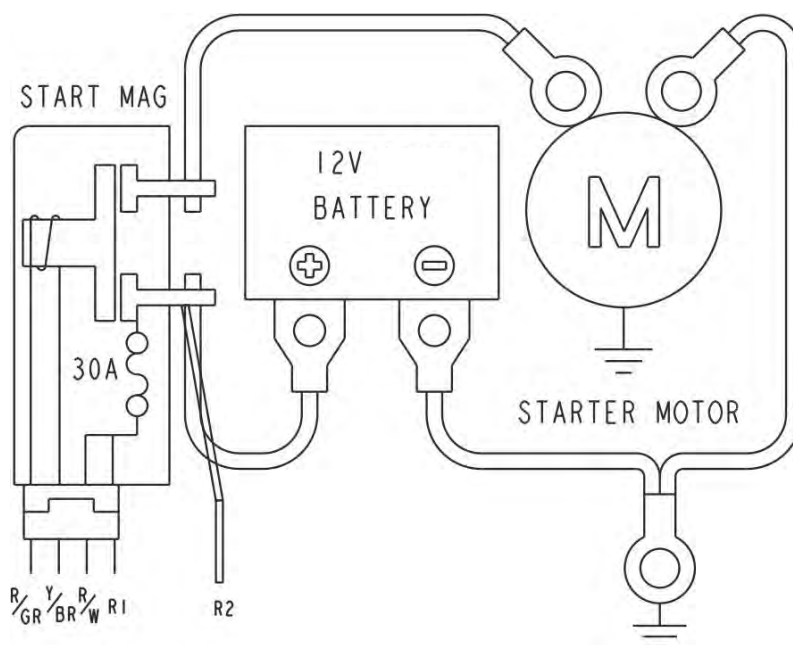

Relays

Seat Open Motor Relay/ Starter Relay/ Fuel Pump Relay/ ECU Relay/ Fan Relay
(The location refer to the wiring diagram wire color)

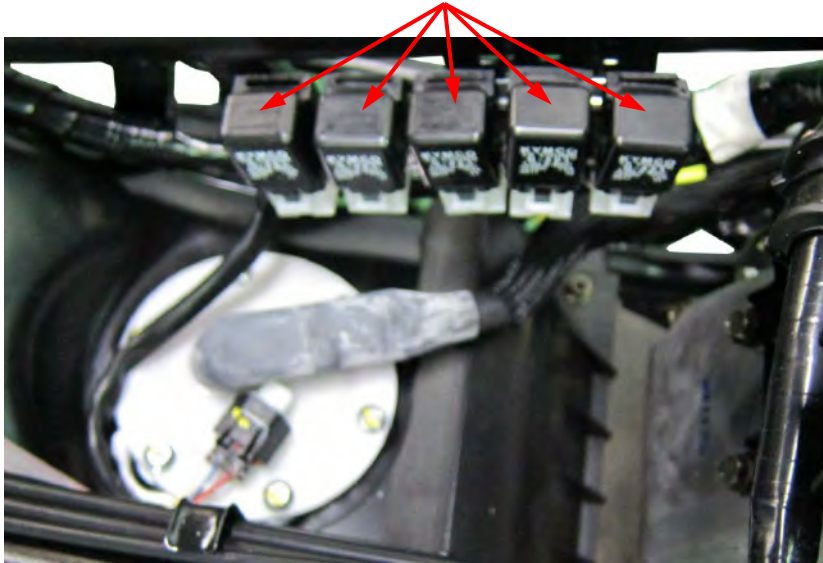

Relays Inspection

Use a digital multimeter to inspect the relay.

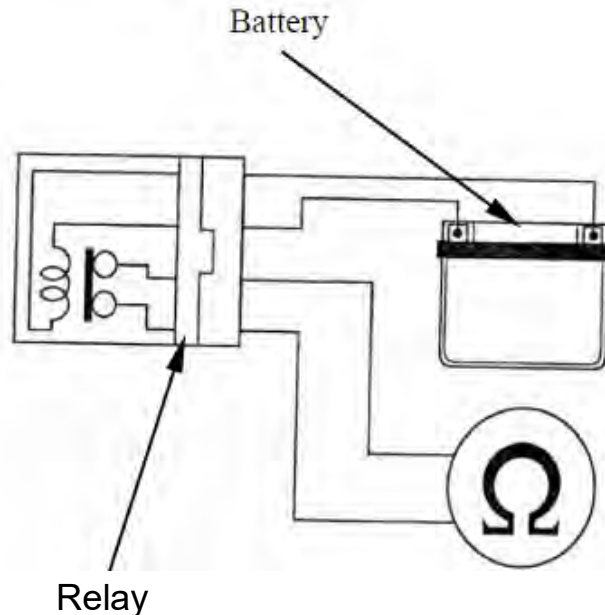

Connect 12 V battery with the fuel cut-off relay connector.

There should be continuity only when 12 V battery connected.

If there is not continuity when the 12 V battery is connected, replace the relay.

Switches

Ignition Switch

Remove the front cover. Unplug the ignition switch connectors. Use a digital multimeter to check for continuity to inspect the ignition switches. Continuity should exist between the wires as indicated.

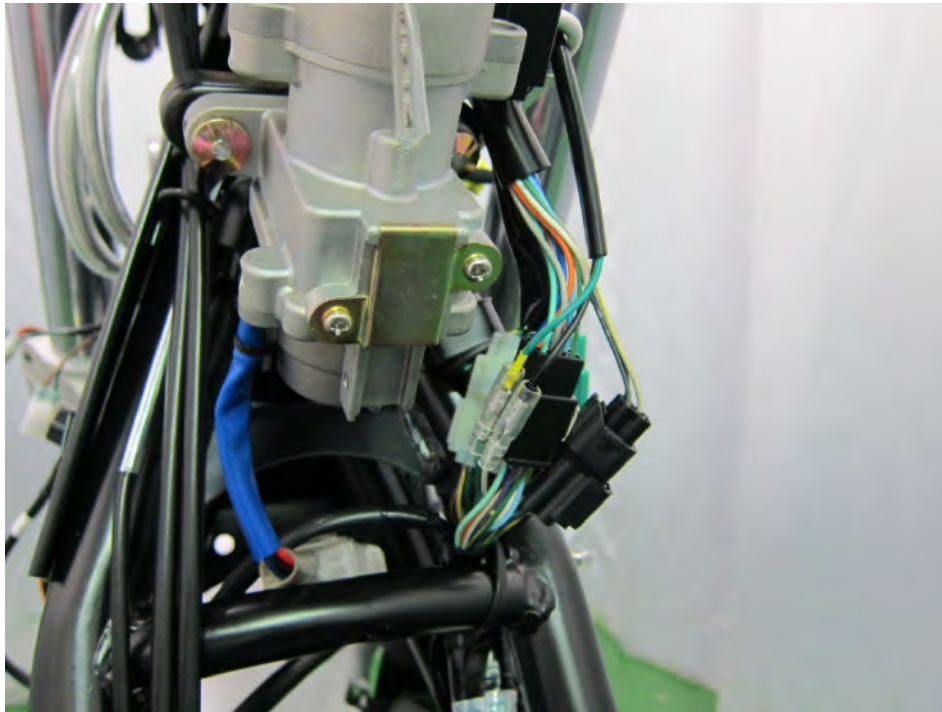

To remove the anti-tamper bolts use a punch and a hammer to strike the bolts so that they rotate loose. Turn the bolts clockwise to loosen them.

COMB SW

	BAT2	IG	E	BAT1	HA
LOCK		○—○			
OFF		○—○		○—○	
ON	○			○—○	
COLOR	B	B/W	G	R	B/L

Luggage Box Light

The lamp lights up when Seat Pad is lifted up, goes out when closed. (The Cabinet Light is provided with light-sensing switch; in case the user forgets to close the Seat Pad or the Pad fails to fully close up, system will cut the power automatically after a set time, preventing any power loss of battery.)

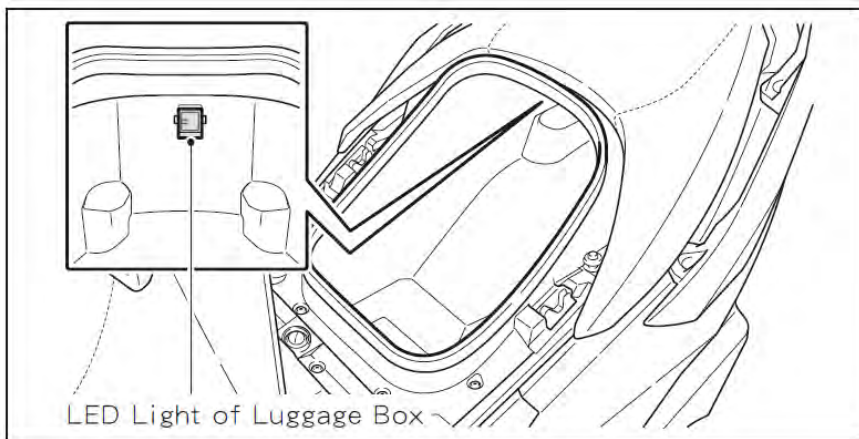
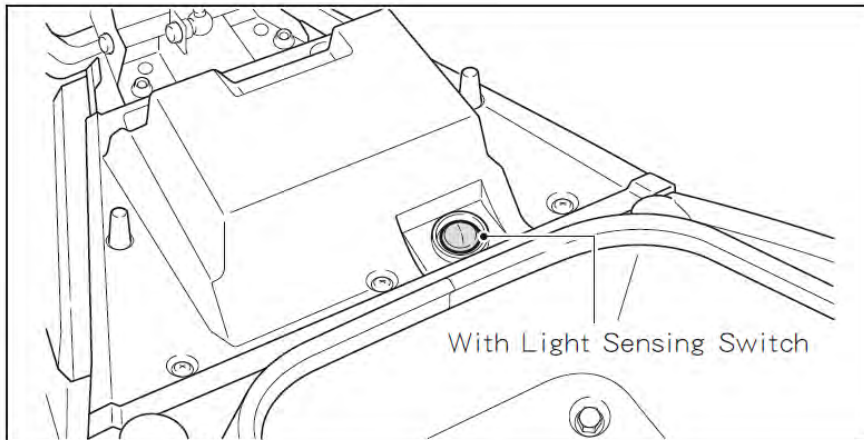

Remove bolts, lift up the luggage box. See the external topic for the details.

Remove the luggage box switches connectors.

Remove the luggage box and switches.



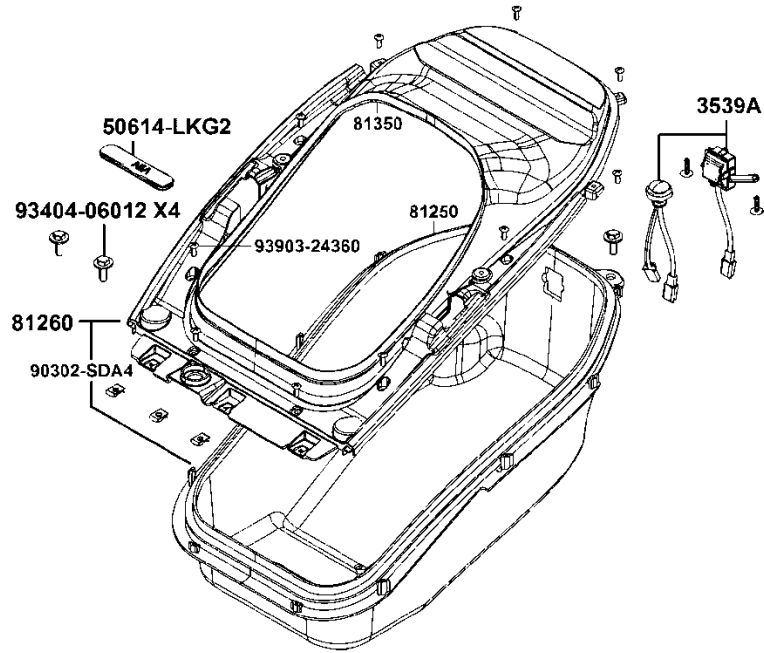

Check the circuit with the wire.

Tilt Switch

Remove the front cover. See the external topic for more information.

Support the scooter level surface.

Put the side stand up and engine stop switch on “RUN”. Turn the ignition switch to “OFF”.

Note: Do not disconnect the tilt switch connector during inspection. The capacity of battery must be fully charged.



Place the tilt switch vertical as shown and the ignition switch “ON”. Measure the voltage as below.

Terminal	Standard
Violet/Red (+) ~ Green/Pink (-)	5 V (ECU voltage)
Black/Blue (+) ~ Green/Pink (-)	0.4 - 1.4 V less

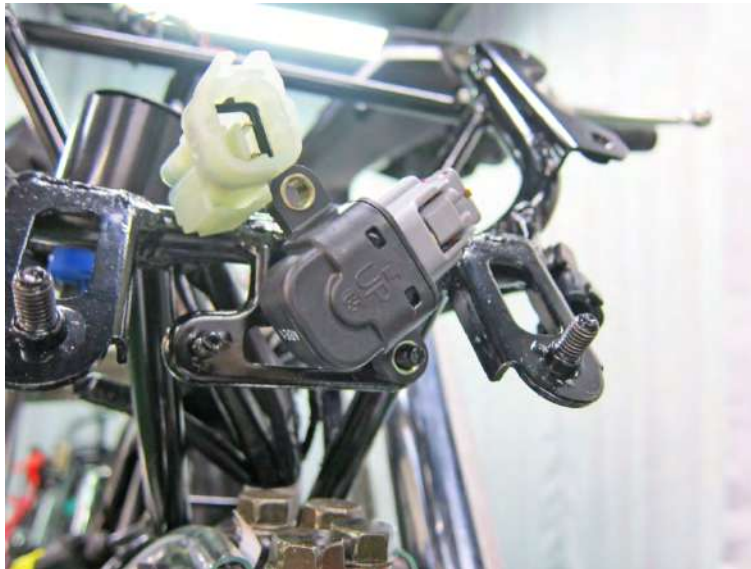

Incline the tilt switch 65 ± 10 degrees to the left or right at the ignition switch “ON”. Measure the voltage as below.

Terminal	Standard
Violet/Red (+) ~ Green/Pink (-)	5 V (ECU voltage)
Black/Blue (+) ~ Green/Pink (-)	3.7 - 4.4 V

Note: Repeat this test, first turn the ignition switch to “OFF”, then turn the ignition switch to “ON”.



Disconnect the connector to remove the tilt switch.

Note: Install the tilt switch with its “up” mark facing up and tighten the two screws securely.

Handlebar Switch

Remove the front cover. See the external topic for more information.

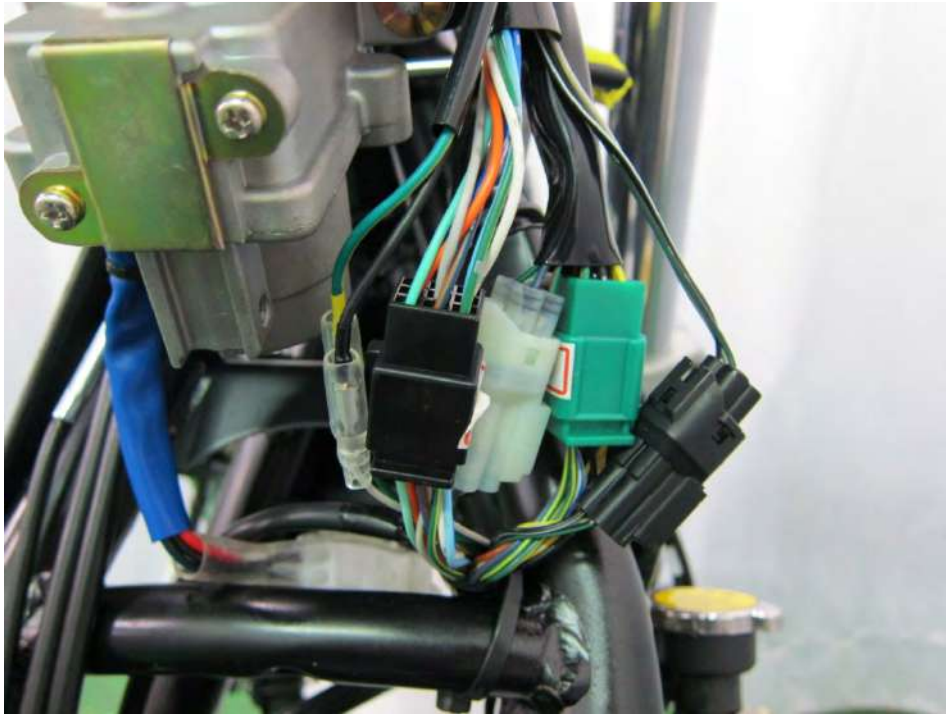

Unplug the black connector for the left handlebar switches.

Unplug the green connector for the right handlebar switches.

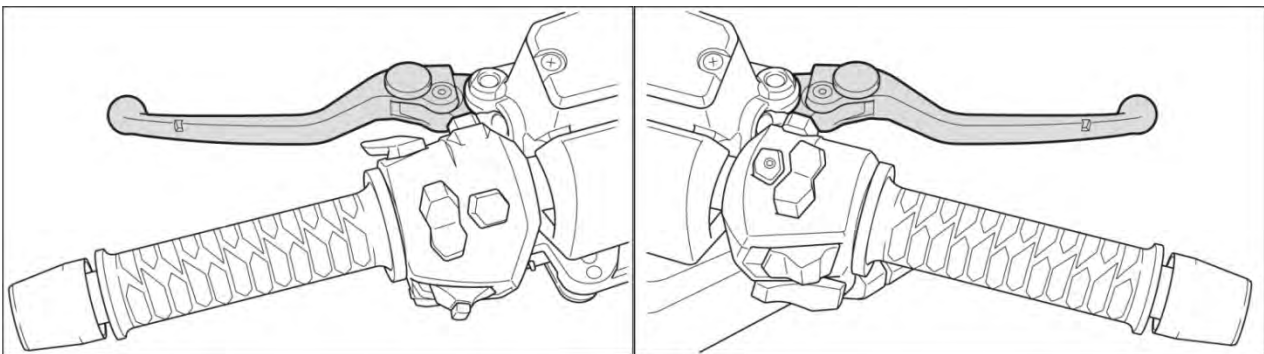

Use a digital multimeter to check for continuity to inspect the handlebar switches. Continuity should exist between the wires as indicated.

Handlebar Switches

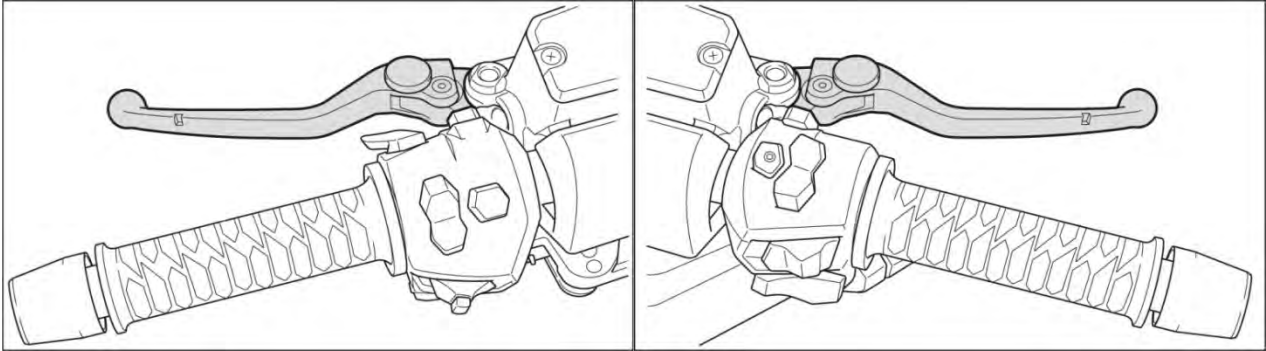

Use a digital multimeter to check for continuity to inspect the handlebar switches. Continuity should exist between the wires as indicated.

HAZARD SW				MIRROR SW			PASSING SW			STARTER SW			ENGINE STOP SW			HORN SW		
	(N)	WR	HA		BAT5	MIRR		BAT4	HI		E	ST		IG	BAT3		BAT4	HO
		○	○	OFF			FREE			FREE			OFF			FREE		
N	○	○	○	ON	○	○	PUSH	○	○	PUSH	○	○	RUN	○	○	PUSH	○	○
○	○	○		COLOR	B/L	V	COLOR	BR/L	L	COLOR	G	Y/R	COLOR	B/W	B/G	COLOR	BR/L	LG

WINKER SW				DIMMER SW				COMB SW					
	WR	R	L		HL	HI	LO		BAT2	IG	E	BAT1	HA
R	○	○		LO	○	○	○	LOCK		○	○		
N				(N)	○	○	○	OFF		○	○	○	○
L	○		○	HI	○	○		ON	○			○	○
COLOR	GR	SB	O	COLOR	W/L	L	W	COLOR	B	B/W	G	R	B/L

Side Stand Switch

Place the vehicle on the center stand.

Unplug the three-pin side stand switch connector.

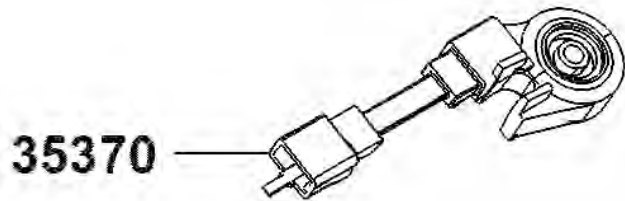

Use a digital multimeter to check for continuity.

With the side stand retracted there should be continuity between the yellow/green wire and the green wire terminals.

With the side stand extended there should be continuity between the yellow/black wire and the green wire terminals.

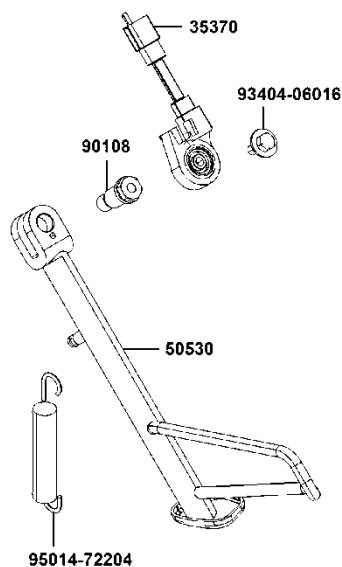

Horn

Remove the front cover. See the external topic for more information.

Disconnect the horn connectors from the horn. Connect a 12 V battery to the horn terminals. The horn is normal if it sounds when the 12 V battery is connected across the horn terminals.

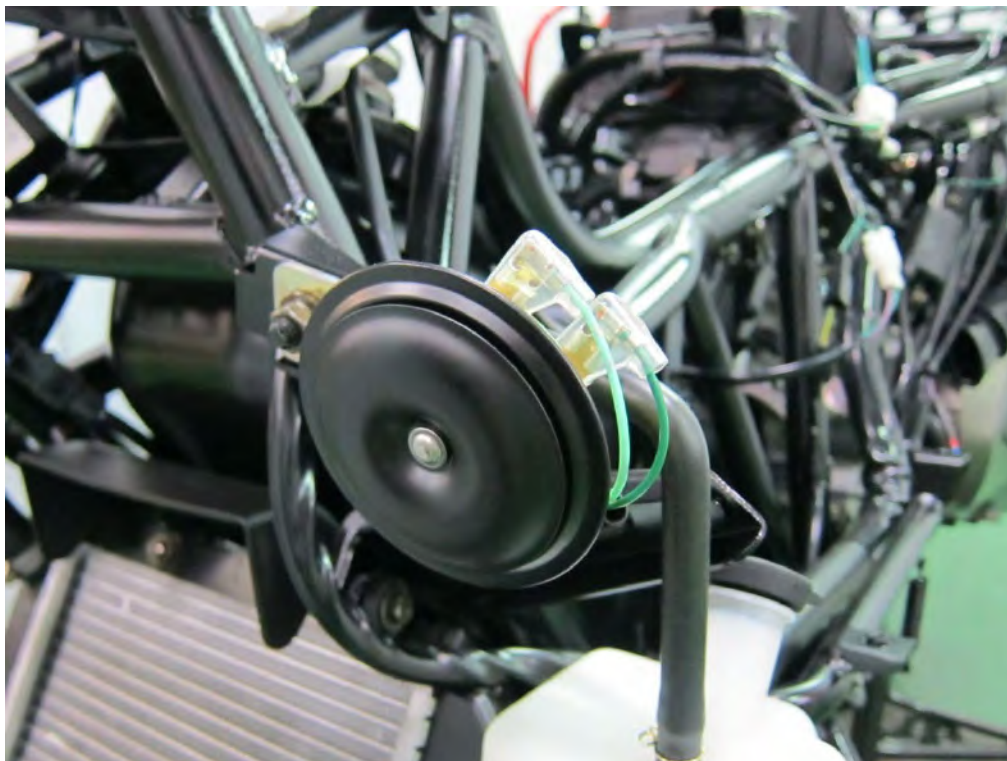

Meter Instrument

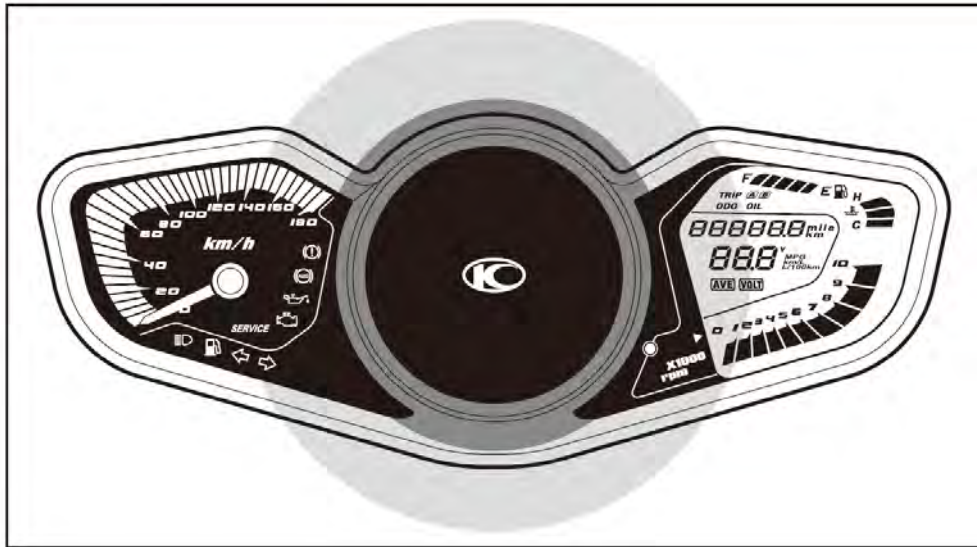

Remove couplers.

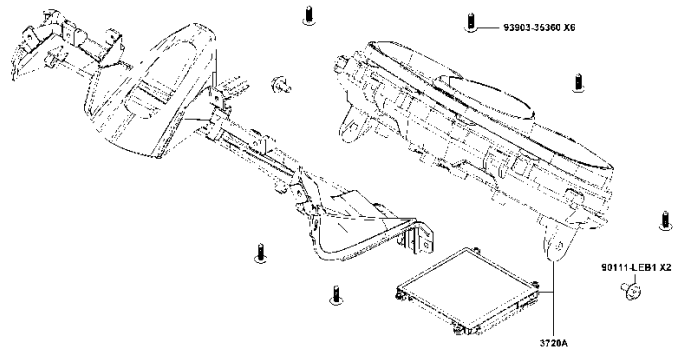

Check the wiring diagram to inspect circuit.

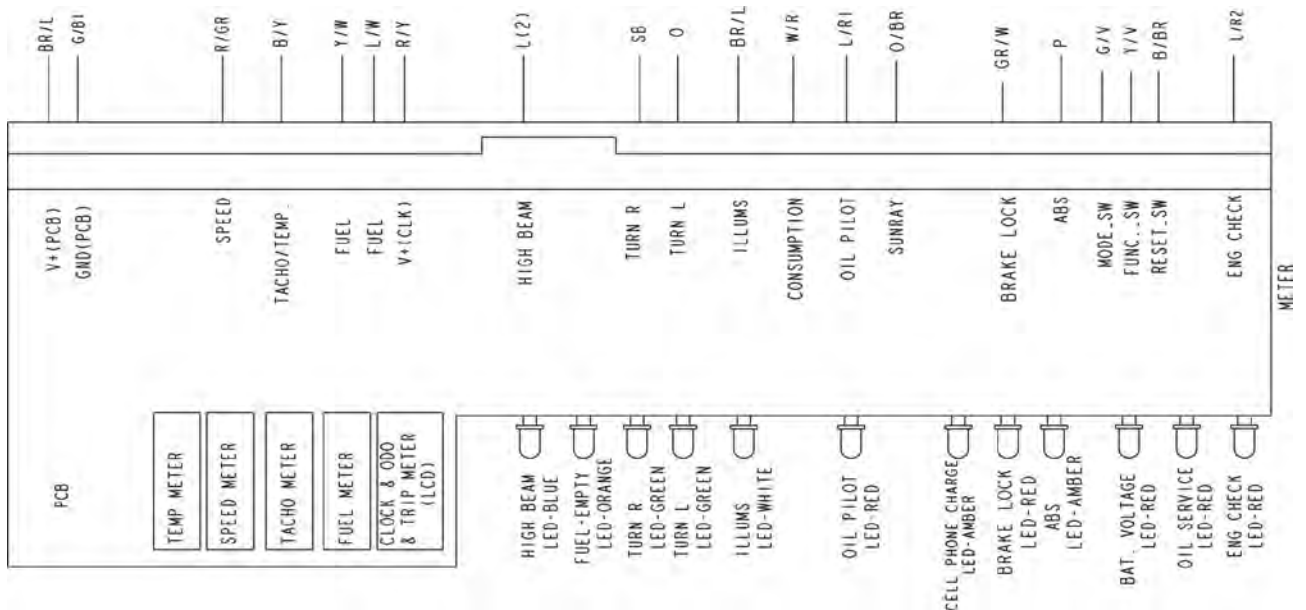

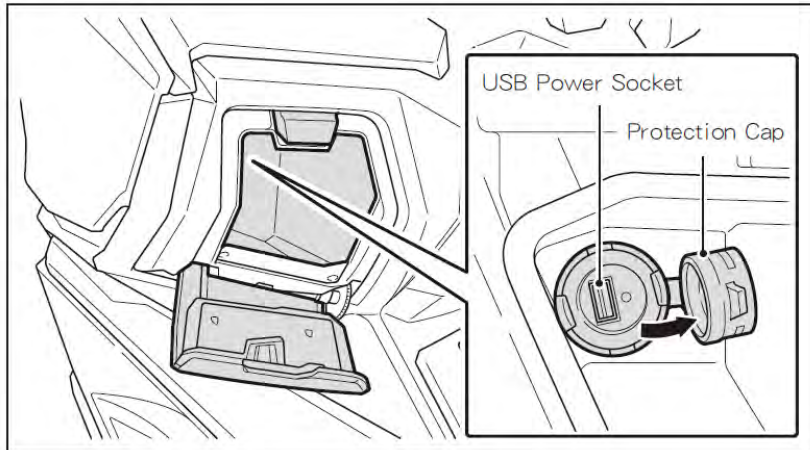
USB Power Socket

This vehicle is provided with a USB Power Socket. You may connect a low power consumption product to the Socket, for charging the product while the engine is running.

⚠ WARNING

- ◆ To avoid electrocution or short-circuit, make sure to cover-up the protection cap after using the USB Power Socket.
- ◆ To prevent any accident from occurring, park your Motorcycle at a safe location before using the USB Power Socket.

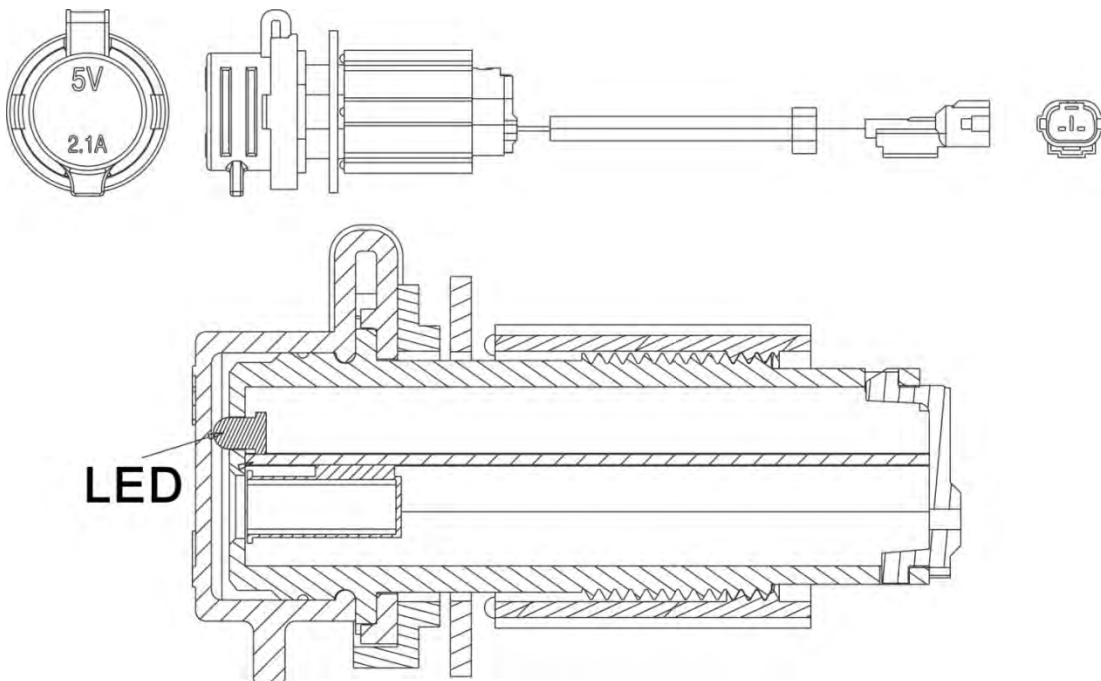

Note:

1. Output voltage: DC 5V \pm 0.5V
2. Max output current: 2.3A \pm 0.2A
3. When charging the LED will turn to red, if not, check the circuit.

10.Brakes

This chapter covers the location and servicing of the brake system components for the KYMCO XCITING S 400 model.

GENERAL INSTRUCTIONS	10-1
TROUBLESHOOTING	10-2
DIAGRAM	10-3
DISC BRAKE	10-4
FRONT CALIPER	10-8
REAR BRAKE PAD	10-13
MASTER CYLINDERS	10-15
PARKING BRAKE	10-18
ABS SYSTEM	10-19
ABS TROUBLESHOOTING OUTLINE	10-24

GENERAL INSTRUCTIONS

- A contaminated brake disc or pad reduces stopping power. Discard contaminated parts and clean a contaminated disc with high quality brake degreasing agent.
- Avoid spilling brake fluid on painted, plastic or rubber parts. Place a rag over these parts whenever the system is serviced.
- Never allow contamination (dirt, water, etc.) to get into and open brake reservoir.
- Once the hydraulic system has been opened, or if the brake feel spongy, the system must be bled.
- Always use fresh DOT 4 brake fluid from a sealed container when servicing the system. Do not mix different types of fluid as they may not be compatible.
- Always check brake operation before riding the vehicle.

Warning: Frequent inhalation of brake pad dust, regardless of material composition could be hazardous to your health. Avoid breathing dust particles.

TROUBLESHOOTING

Brake lever soft or spongy

- Air in the hydraulic system
- Low brake fluid level
- Clogged fluid passage
- Contaminated brake disc pad
- Warped/deformed brake disc
- Worn brake disc pad
- Sticking worn master cylinder piston
- Contaminated master cylinder
- Contaminated caliper
- Caliper not sliding properly
- Leaking hydraulic system
- Worn caliper piston seal
- Worn master cylinder piston cups
- Bent brake lever

Brake lever hard

- Clogged restricted brake system
- Sticking/worn caliper piston
- Caliper not sliding properly
- Clogged restricted fluid passage
- Worn caliper piston seal
- Sticking worn master cylinder piston
- Bent brake lever

Brake drag

- Contaminated brake disc pad
- Worn brake disc pad
- Warped/deformed brake disc
- Caliper not sliding properly

Diagram

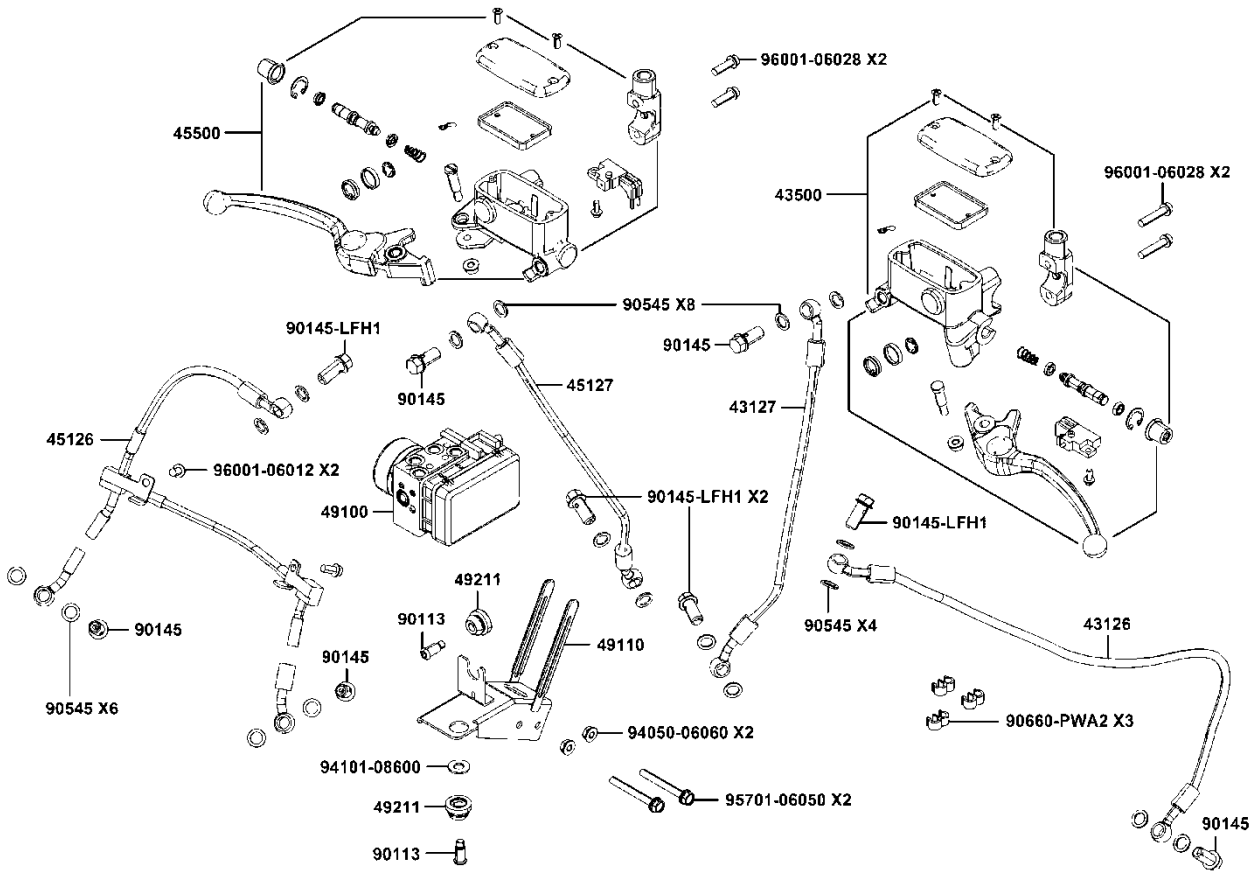

Disc Brake

SAFETY FIRST: Protective gloves and eyewear are recommended at this point.

Inspection



Measure the thickness of the brake rotor with a micrometer.

Item	Standard mm (in)	Service Limited
Brake disk thickness (rear)	4.8 - 5.2 (0.19 - 0.20)	4 (0.16)
Brake disk thickness (front)	3.8 - 4.2 (0.15 - 0.17)	3 (0.12)



Check if the brake rotor runout is within the service limit.

Measure the runout of the brake disc with a dial gauge. If the reading is out of specification remove the disc from the wheel and recheck.

Item	Standard mm (in)	Service Limited
Brake disc runout	—	0.03 (0.012)

Front

Removal



Remove the five mounting bolts with a 6 mm Allen.



To remove the front brake disc take out the five mounting bolts with a 8 mm Allen.



Remove the front brake discs.

Installation



Fit the brake disc into place as shown.



Coat the threads of the disc bolts in a non-permanent thread locking agent. Thread in the bolts and torque them to specification with an Allen socket.

Item	Qty	Thread dia.(mm)	Torque
			Nm (kgf-m, ft-lb)
Brake disc bolt	5	8	35 (3.5, 25)

Install the front wheel. See the Front Wheel topic for more information.

Rear

Removal



To remove the rear brake disc take out the five mounting bolts with a 6 mm Allen.



Lift off the rear brake disc.

Installation



Fit the rear brake disc into place on the wheel as shown.



Apply a non-permanent thread locking agent to the threads of the rear disc bolts. Insert the bolts and tighten them to specification with a 6 mm Allen.

Item	Qty	Thread dia.(mm)	Torque
			Nm (kgf-m, ft-lb)
Brake disc bolt	5	8	35 (3.5, 25)

Front Caliper

SAFETY FIRST: Protective gloves and eyewear are recommended at this point.

Removal

Brake Pads



Push the caliper body inward to push in the pistons.

This will allow room to change the brake pads.



Remove the two caliper mounting bolts with a 12 mm socket.

Discard the brake caliper mounting bolts.



Remove the front brake caliper.

The brake calipers are each mounted to the front fork with two bolts.



Remove the brake pads with a 6mm Allen.



Free the brake pads from the pad retainer.

Remove the brake pads.



Remove the brake pad Clips with a splcier.



Replace the pads if the brake wear exceeds the wear indicator lines or if the wear is uneven.
Always replace brake pads as a set.

Caliper



Place a suitable container under the banjo bolt to catch any remaining brake fluid. Remove the banjo bolt that holds the brake hose to the caliper using a 12 mm socket. Discard the two sealing washers.

The brake calipers are each mounted to the front fork with two bolts.

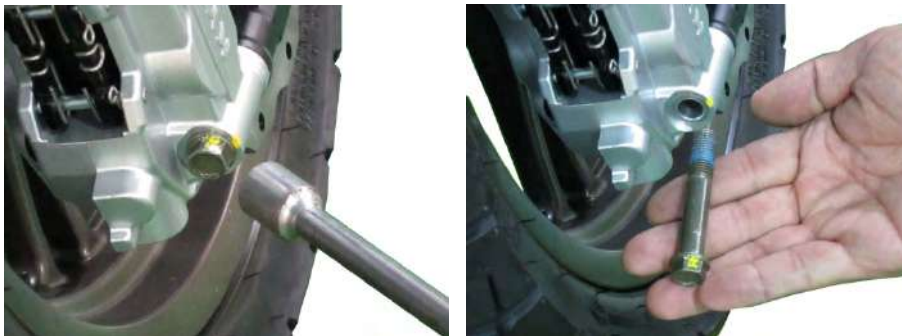

Remove the two caliper mounting bolts with a 12 mm socket. Discard the brake caliper mounting bolts.

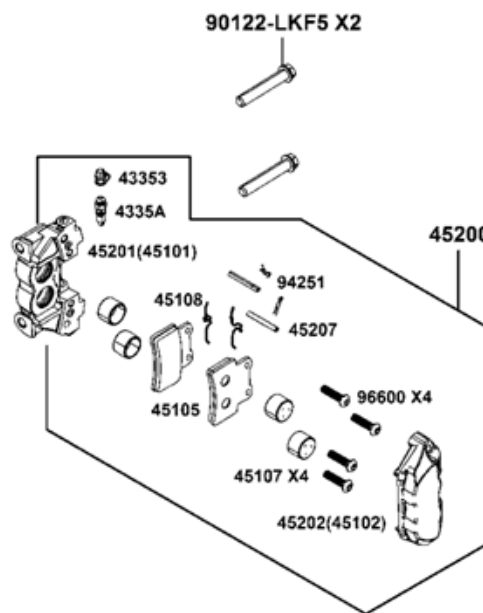

Remove the brake caliper from the fork leg.

Installation



Install the front caliper. Guide the brake disc between the pads. Line up the caliper bracket mounts with the fork.



Install the two new caliper bracket mounting bolts. Tighten the mounting bolts to specification.

Item	Q'ty	Thread dia.(mm)	Torque	Remarks
			Nm (kgf-m, ft-lb)	
Front caliper mounting bolt	4	10	35 (3.5, 25)	Replace a new one



Install the banjo bolt with new sealing washers and tighten to specification with a 12 mm socket.

Item	Q'ty	Thread dia.(mm)	Torque
			Nm (kgf-m, ft-lb)
Brake fluid bolt	2	10	35 (3.5, 25)

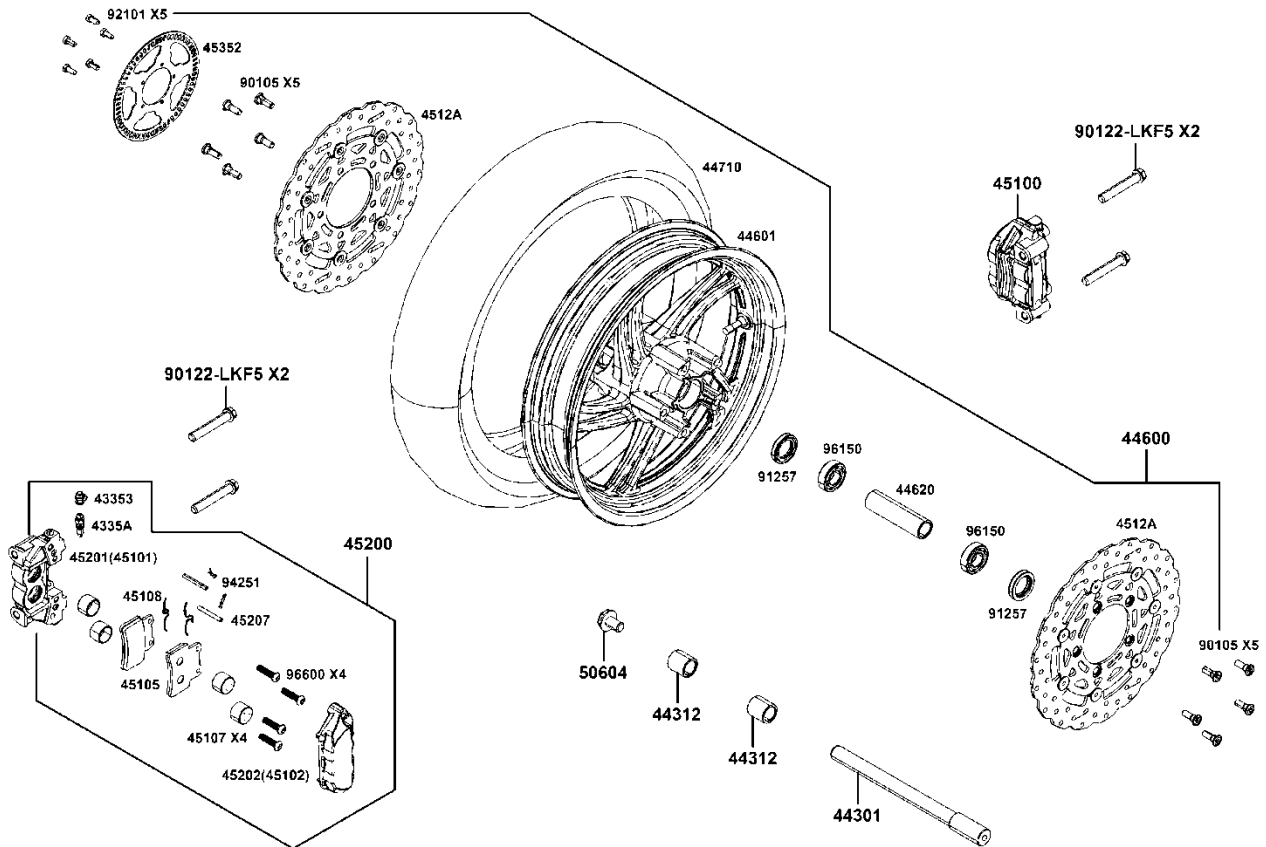

When installation:

Apply a light coat of waterproof grease to the brake pad pin. Push the pads against the pad spring and insert the brake pad pin.

It may be necessary to spread the pads and force the pistons back into the caliper in order to allow room for the brake disc to fit between the new pads.

Install the front caliper. Guide the brake disc between the pads. Line up the caliper bracket mounts with the fork.

Install the two caliper bracket mounting bolts. Tighten the mounting bolts to specification.

Rear Brake Pad Removal

SAFETY FIRST: Protective gloves and eyewear are recommended at this point.

Warning: Brake fluid is very caustic and can damage paint, chrome and plastic.
Wipe up any spills immediately.

Removal



Place a suitable container under the banjo bolt to catch any remaining brake fluid. Remove the banjo bolt that holds the brake hose to the caliper using a 12 mm socket. Discard the two sealing washers.

Remove the rear brake caliper from the rear fork.



Free the parking brake cable from the rear brake caliper.



Remove the brake pad pin plug with a flat blade screwdriver.



Loosen the brake pad pin with a 5 mm Allen.
Remove the brake pad pin with a 5 mm Allen.



Free the brake pads from the pad retainer.
Remove the brake pads.



Replace the pads if the brake wear exceeds the wear indicator lines or if the wear is uneven.
Always replace brake pads as a set.

When installation:

Apply a light coat of waterproof grease to the brake pad pin. Push the pads against the pad spring. It may be necessary to rotate the piston and force the pistons back into the caliper in order to allow room for the brake disc to fit between the new pads.

Install the rear caliper. Guide the brake disc between the pads. Install the two caliper bracket mounting bolts. Tighten the mounting bolts to specification.

Master Cylinders

Up And Low Handle Cover Removal

Remove the top handle cover.

Remove the bolts, screws and remove the up handle cover.



Remove the bolts, screws.

Remove throttle and parking brake cables and remove the low handle cover.

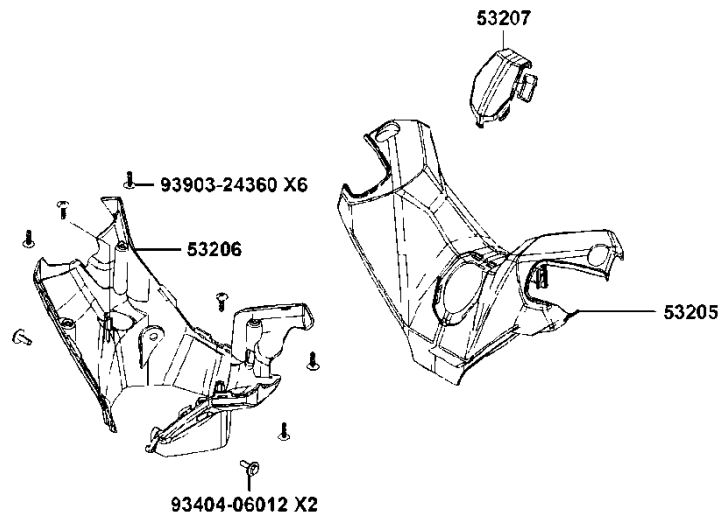

SAFETY FIRST: Protective gloves and eyewear are recommended at this point.

Draining

The brake bleeding process is the same for the front and rear brakes. Remove the two master cylinder cover screws with a #2 Phillips head screwdriver. Remove the master cylinder cover, plastic piece and rubber accordion diaphragm. Pour out any remaining brake fluid.

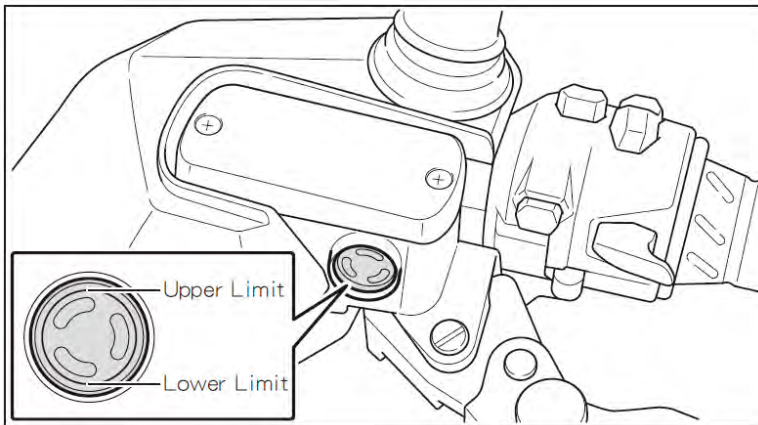

Clean and inspect the rubber diaphragm for tears or other damage. Replace as necessary.



Pull off the rubber cap over the bleeder valve and crack open the bleeder valve on the brake caliper using an 8 mm wrench. This valve is usually very tight so use a box end wrench or a 6 point socket and ratchet to prevent rounding off the head. Snug the bleeder valve back down.

Open the valve and remove the old brake fluid with a Mighty -Vac or a similar device.

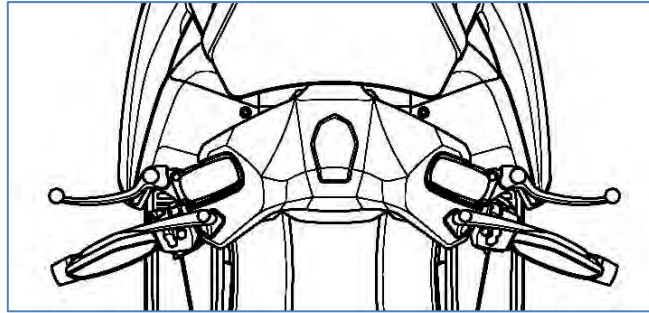

Pump the brake lever several times and hold the lever in. While holding the lever in, crack open the bleeder valve. The front brake lever will travel all the way to the grip and brake fluid and/or air will come out of the bleeder valve into the 6 mm hose. Tighten the bleeder valve before releasing the front brake lever. Pump the lever several times again and repeat the process.

Be certain to check the master cylinder reservoir occasionally to make sure the reservoir doesn't run dry. Add more brake fluid as necessary. Continue this process until clean brake fluid comes out of the bleeder valve and there are no air bubbles. The brake lever should feel firm.

Tighten the bleeder valve to specification and push its rubber cover over the nipple.

Make sure the reservoir has the proper amount of fluid.

Place the rubber diaphragm, plastic piece and cover over the reservoir.

Thread in the reservoir cover screws and tighten them securely with a #2 Phillips screwdriver.

Check the function of the brakes before operating the machine.

Parking Brake Adjustment

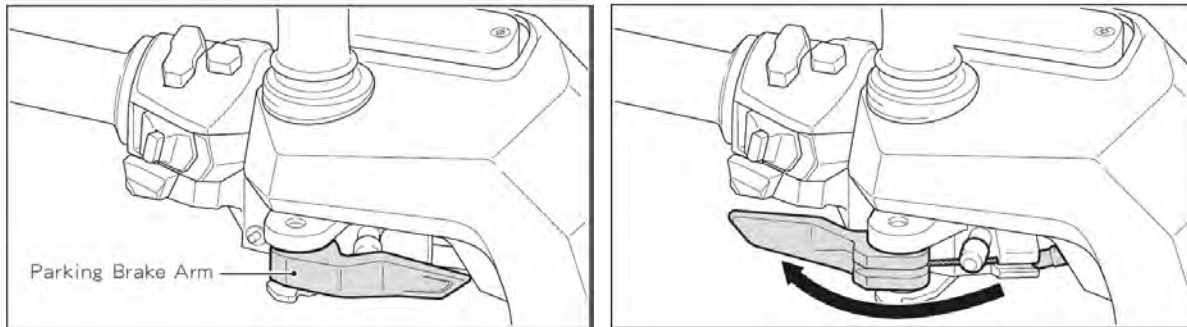

Release the fixed nut, and rotate the adjust nut to adjust the parking brake.

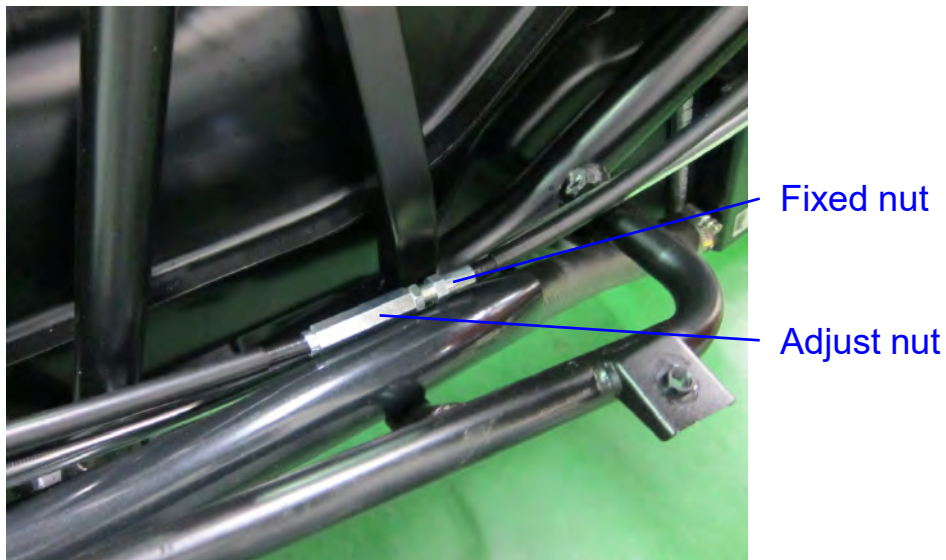

Note: Do not use the rear brake lock lever while driving.



Note: Do not use the rear brake lock lever while driving.

ABS

SAFETY FIRST: Protective gloves and eyewear are recommended at this point.

ABS Component Location

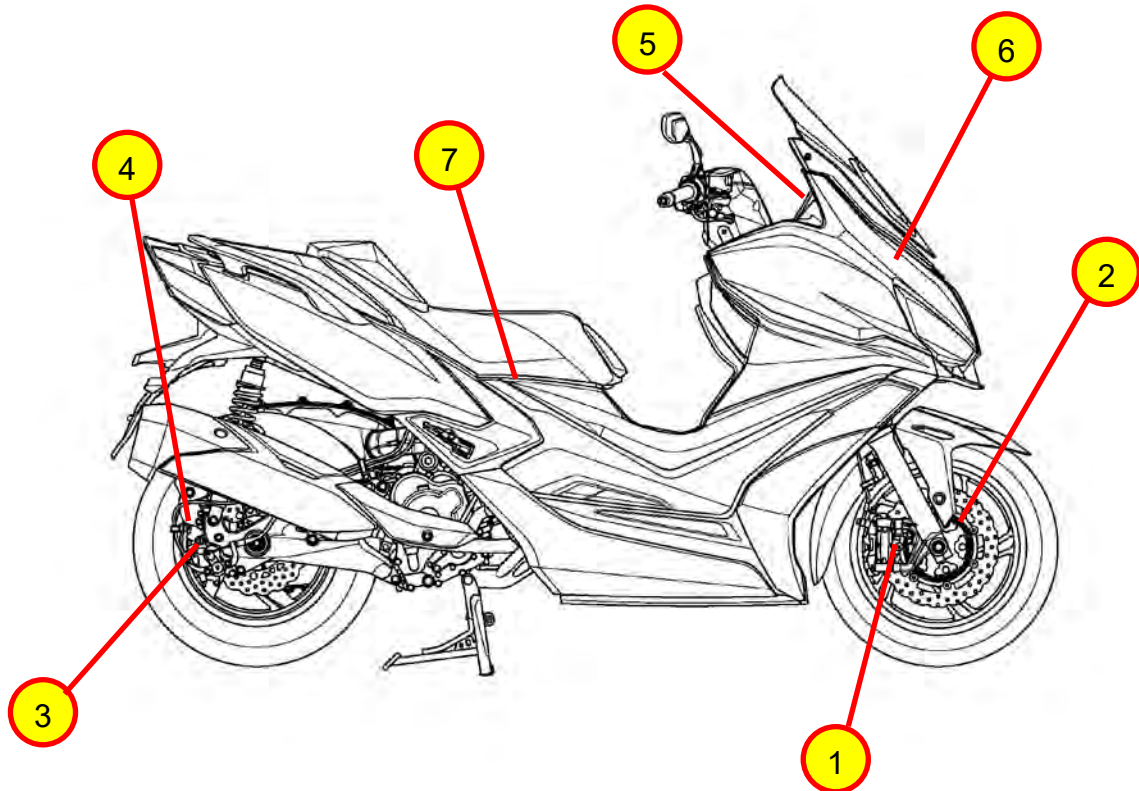

1. Front Wheel speed Sensor
2. Front Wheel speed Sensor Rotor
3. Rear Wheel speed Sensor
4. Rear Wheel speed Sensor Rotor
5. ABS Indicator Light
6. ABS Hydraulic Unit
7. ABS diagnosis tool Connector (Near battery position)

Introduction to KYMCO Anti-Lock Brake

System

ABS is designed to help prevent the wheels from locking up when the brakes are applied hard while running straight. The ABS automatically regulates brake force.

Intermittently gaining gripping force and braking force helps prevent wheel lock-up and allows stable steering control while stopping.

Brake control function is identical to that of conventional vehicle. The brake lever is used for the front brake and rear brake.

Although the ABS provides stability while stopping by preventing wheel lock-up, remember the following characteristics:

It is recommended to pay attention therefore in cases of braking in low grip conditions at low speed.(For example braking on garage floor tiles after having ridden on wet roads or similar situations).

- ABS can not compensate for adverse road conditions, misjudgment or improper application of brakes. You must take the same care as with vehicle not equipped with ABS.
- ABS isn't designed to shorten the braking distance. On loose, uneven or downhill surfaces, the stopping distance of a vehicle with ABS may be longer than that of an equivalent vehicle without ABS. Use special caution in such areas.
- ABS will help prevent wheel lock-up when braking in straight line but it cannot control wheel slip which may be caused by braking during cornering. When turning a corner, it is better to limit braking to a light application of both brakes or not to brake at all. Reduce your speed before you get into the corner.
- The computers integrated in the ABS compare vehicle speed with wheel speed. Since non-recommended tires can affect wheel speed, they may confuse the sensors resulting in extended braking distance.

Caution: Use of non-recommended tires may cause malfunctioning of ABS and lead to extended braking distance. The rider could have an accident as a result. Always use the standard tires for this vehicle.

Notice:

- When the ABS is functioning, you may feel a pulsing in the brake lever. This is normal - you need not suspend applying the brakes.
- ABS does not function below speeds of approximately 10 kph or 6 mph.
- ABS does not function if battery is discharged or there is a battery power supply malfunction (ABS light will come on).

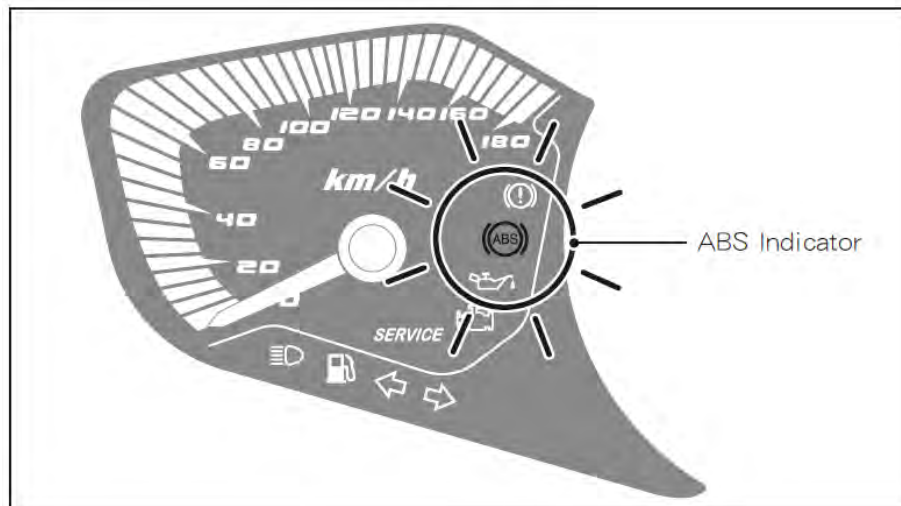

ABS Servicing Precautions

There are a number of important precautions that should be followed servicing the ABS system.

- This ABS system is designed to be used with a 12V sealed battery as its power source. Do not use any other battery except for a 12V sealed battery as a power source.
- Do not reverse the battery cable connections. This will damage the ABS hydraulic unit.
- To prevent damage to the ABS parts, do not disconnect the battery cables or any other electrical connections when the ignition switch is ON or while the engine is running.
- Take care not to short the leads that are directly connected to the battery positive (+) terminal to the chassis ground.
- Do not turn the ignition switch is ON while any of the ABS electrical connectors are disconnected. The ABS hydraulic unit memorizes service codes.
- Do not spray water on the electrical parts, ABS parts, connectors, leads and wiring.
- Whenever the ABS electrical connections are to be disconnected, first turn off the ignition switch.
- The ABS parts should never be struck sharply, as with a hammer, or allowed to fall on a hard surface. Such a shock to the parts can damage them.
- The ABS parts cannot be disassembled. Even if a fault is found, do not try to disassemble and repair the ABS parts, replace the ABS unit with a new component.
- The ABS has many brake lines, pipes, and leads. And the ABS cannot detect problems with the conventional braking system (brake disk wear, unevenly worn brake pads and other mechanical faults). To prevent trouble, check the brake lines and pipes for correct routing and connection, the wiring for correct routing, and the brakes for proper braking power. Be sure to check for fluid leaking, and bleed the brake line thoroughly.

Caution

If any of the brake line fittings, including the ABS hydraulic unit joint nuts, or the bleed valve are opened at any time, the air must be bled completely from the brake line.

Do not ride the scooter with air in the brake line, or the ABS could malfunction.

- The ABS indicator light may light if the tire pressure is incorrect, a non-recommended tire is installed, or the wheel is deformed. If the indicator light lights, remedy the problem and clear the service code.
- When the ABS operates, the ABS makes noise and the rider feels the reaction force on the brake lever and brake pedal. This is a normal condition. It informs the rider that the ABS is operating normally.
- Service codes detected once by the ABS hydraulic unit will be memorized in the ABS hydraulic unit. Therefore, after maintenance work is finished, be sure to erase the service codes. Do not erase the service codes during troubleshooting. Wait until all the checks and repair work is finished to prevent duplication of previous service codes and unnecessary maintenance work.
- Before delivering the scooter to the customer, be sure to erase any service codes which might be stored in the ABS hydraulic unit. Test run the scooter at a speed of more than 10 kph (6 mph) to see that the ABS indicator light does not come on. Finally, test run the scooter at a speed of more than 30 km/h (20 mph) and brake suddenly to see that the scooter stops without loss of steering control and the ABS operates normally. (The reaction force generated is felt in the brake lever and pedal.) This completes the final inspection.

ABS Troubleshooting Outline

The ABS indicator light lights up to alert the rider when an abnormality is detected by the system. The service codes are stored in the ABS unit memory. The codes will not be erased unless manually cleared. After the fault has been corrected erase the service codes.

Even when the ABS is operating normally, the ABS indicator light may light up under the conditions listed below. Turn the ignition switch OFF to stop the indicator light. If the scooter runs without erasing the service codes, the light may light up again.

- After continuous riding on a rough road.
- When the ABS has been subjected to strong electrical interference.
- When tire pressure is abnormal. Adjust tire pressure.
- When a tire different in size from the standard size is being used. Replace with standard size.

- When the wheel is deformed. Replace the wheel.

Much of the ABS troubleshooting work consists of confirming continuity of the wiring. The ABS parts are assembled and adjusted by the manufacturer, so there is no need to disassemble or repair them. Replace the ABS hydraulic unit if needed.

The basic troubleshooting procedures are listed below.

- Carry out pre-diagnosis inspections as a preliminary inspection.
- Check wiring and connections from the ABS hydraulic unit connector to the suspected ABS part, using the diagnosis tool.

Special tool - Diagnosis tester: 3620A-LEB2-E00

- Visually inspect the wiring for signs of burning or fraying. If any wiring is poor, replace the damaged wiring.
- Pull each connector apart and inspect it for corrosion, dirt and damage. If the connector is corroded or dirty, clean it carefully. If it is damaged, replace it.
- Check the wiring for continuity.

Pre-diagnosis Inspection Chart 1

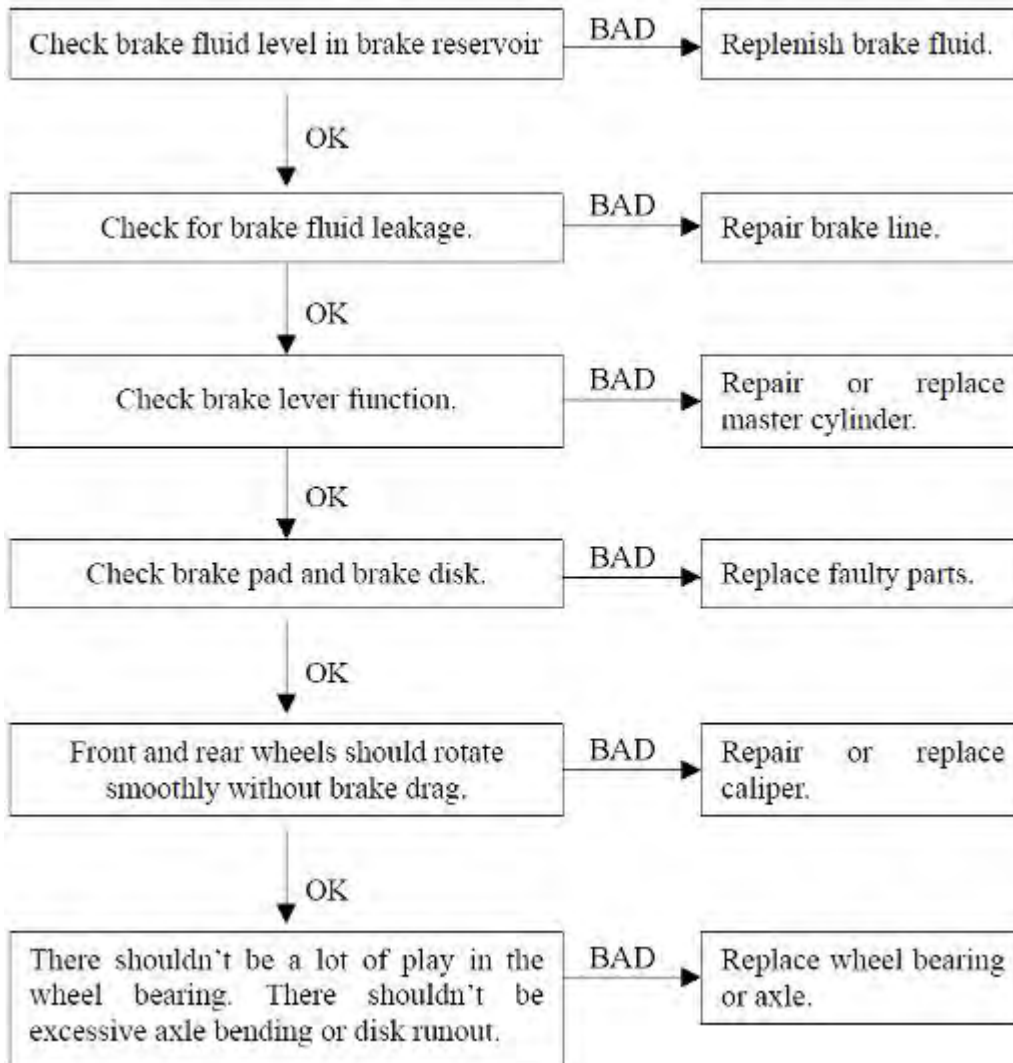

Pre-diagnosis Inspection Chart 2

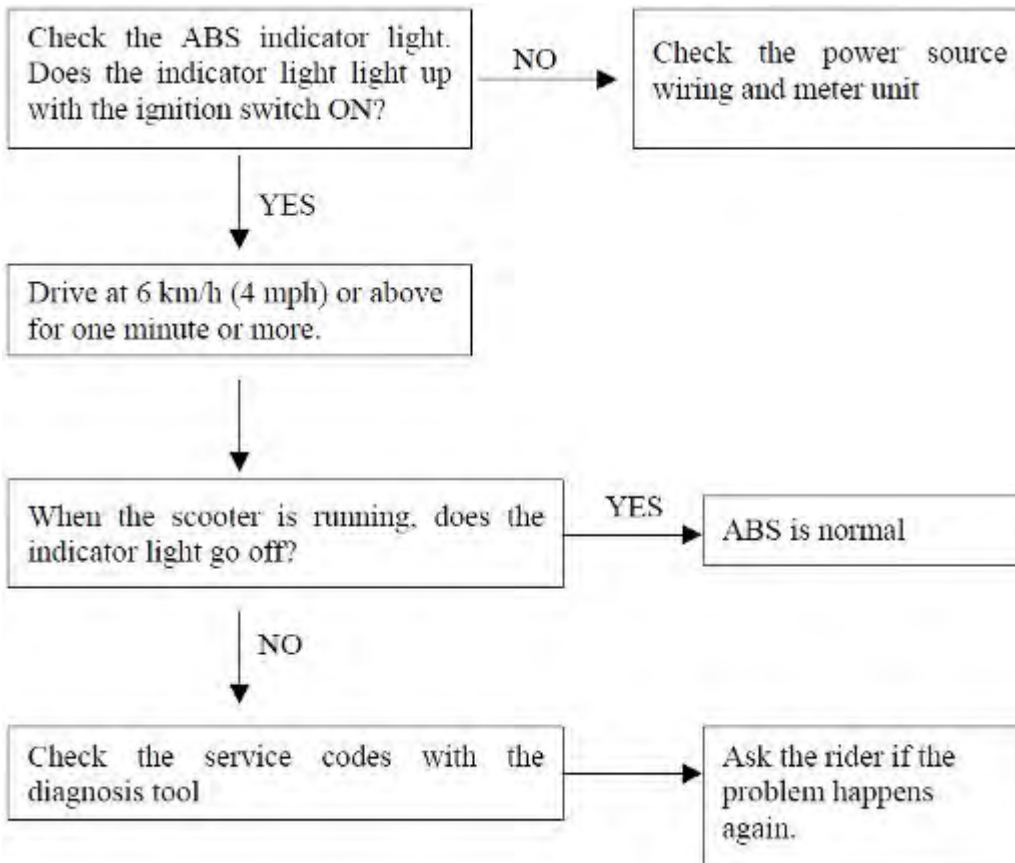

Meter Instruments

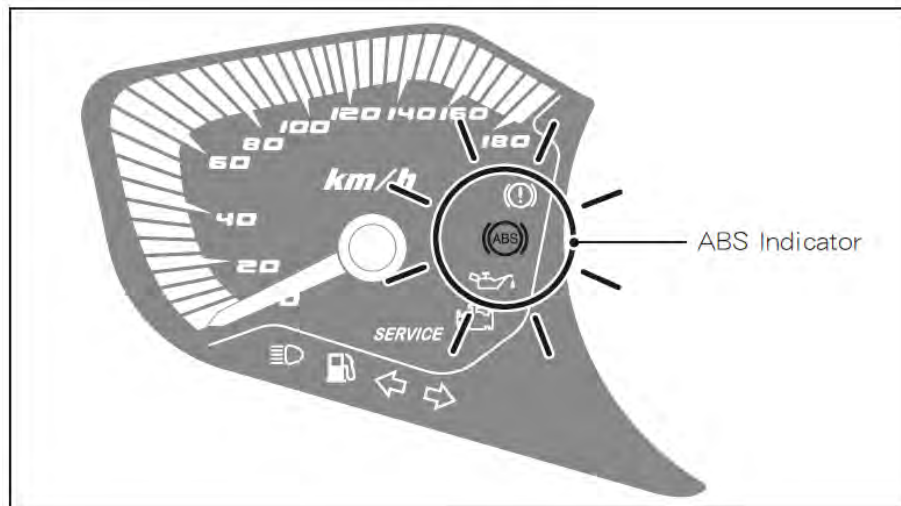

The ABS indicator light is on the left side of the meter. This light will come on when the ignition switch is turned on and goes off shortly after the vehicle starts moving. The light stays off as long as the system is ok.

If something is wrong with the ABS the indicator comes on and remains on. When the indicator light is on the ABS doesn't function, but the conventional brake system will still work normally.

ABS Indicator Light Is Unlit (When The Ignition Switch Turned To ON)

1st step test.

Disconnect the meter connector.

Check the terminal voltage between the ABS signal wire (Pink lead) terminal of the meter connector and ground. Turn the ignition switch ON.

Terminal Voltage

Standard: About 8V

If the terminal voltage correct, replace the meter assembly.

2nd step test.

Disconnect the meter connector.

Check for continuity between the ABS signal wire (Pink lead) terminal of the main harness side connector and ground.

If there is the continuity in the lead, replace or repair the main harness.

3rd step test.

Disconnect the ABS hydraulic unit connector.

Check for continuity between the ABS signal wire (Pink lead) terminal of the meter side connector and the ABS signal wire (Pink lead) terminal of the ABS unit side connector.

If there is the continuity in the lead, replace the ABS hydraulic unit.

If there is not the continuity in the lead, replace or repair the main harness.

ABS Indicator Light lights (When the scooter is running, - no service code)

1st step test.

Disconnect the ABS hydraulic unit connector and meter connector.

Check for continuity between the ABS signal wire (Pink lead) terminal of the meter side connector and the ABS signal wire (Pink lead) terminal of the ABS unit side connector.

If there is the continuity in the lead, replace the ABS hydraulic unit.

If there is not the continuity in the lead, replace or repair the main harness.

Solenoid Valve Inspection (Service Code 13,14,17,18)

1st step test.

Recheck the service code indication: erase the service code, perform the pre-diagnosis inspection 1 and 2. and retrieve the service code.

If the ABS indicator light lit, faulty solenoid valve in the ABS hydraulic unit. Replace the ABS hydraulic unit.

If the ABS indicator light unlit. ABS system is normal.

ABS solenoid valve relay inspection (service code 19)

1st step test.

Check the ABS solenoid valve relay fuse (25A).

Front, Rear Wheel Rotation Difference Abnormal (service code 25)

1st step test.

Check the following and correct the faulty part.

1. Incorrect the tire pressure
2. Tire not recommended for the scooter were installed (incorrect tire size).
3. Deformation of the wheel or tire.
4. Sensor rotor for missing teeth and clogging with foreign matter.

If the all parts are correct move on to the 2nd step.

2nd step test.

Recheck the service code indication: erase the service code, perform the pre-diagnosis inspection 1 and 2, and retrieve the service code.

If the ABS indicator light lit, faulty ECU in the ABS hydraulic unit. Replace the ABS hydraulic unit.

If the ABS indicator light unlit. ABS system is normal.

ABS Motor Relay Inspection (service code 35)

1st step test.

Check the ABS motor relay fuse (25A).

Front Wheel Rotation Sensor Signal Abnormal (service code 42)

1st step test.

Measure the clearance between the front wheel rotation sensor and sensor rotor.

Standard: 1 mm (0.04 in.)

If the measurement is over standard, check each part for deformation and looseness and correct accordingly. Recheck the clearance.

Check that there is iron or other magnetic deposits between the sensor and sensor rotor, and the sensor rotor slots for obstructions.

Check the installation condition of the sensor for looseness.

Check the sensor and sensor rotor tip for deformation or damage (example chipped sensor rotor teeth).

Front Wheel Rotation Sensor Wiring Inspection (service code 43)

1st step test.

Disconnect the ABS hydraulic unit connector and front wheel sensor connector.

Short the white/brown and red-green lead terminals of the main harness side connector with a jumper lead, and check for continuity between the white/brown and red green lead terminals of the main harness side connector.

If there is not the continuity in the lead, replace the rear wheel rotation sensor.

Rear Wheel Rotation Sensor Wiring Inspection (service code 44)

1st step test.

Measure the clearance between the rear wheel rotation sensor and sensor rotor.

Standard: 1 mm (0.04 in.)

If the measurement is over standard, check each part for deformation and looseness and correct accordingly. Recheck the clearance.

Check that there is iron or other magnetic deposits between the sensor and sensor rotor, and the sensor rotor slots for obstructions.

Check the installation condition of the sensor for looseness.

Check the sensor and sensor rotor tip for deformation or damage (example chipped sensor rotor teeth).

Rear Wheel Rotation Sensor Wiring Inspection (service code 45)

1st step test.

Disconnect the ABS hydraulic unit connector and rear wheel sensor connector.

Short the light-blue/brown and black/red lead terminals of the main harness side connector with a jumper lead, and check for continuity between the light-blue brown and black/red lead terminals of the main harness side connector.

If there is not the continuity in the lead, replace the rear wheel rotation sensor.

Power Supply Voltage Abnormal (under-voltage) (service code 52)

1st step test.

Disconnect the ABS diagnosis connector and ABS hydraulic unit connector.

Check for continuity for the black lead terminal of the main harness side connector.

2nd step test.

Connect the ABS diagnosis connector and ABS hydraulic unit connector.

Check the battery terminal voltage, connect the diagnosis tool to the ABS diagnosis connector.

Turn the ignition switch ON.

Battery terminal voltage
Standard: 9.6V or more

3rd step test.

Inspect the following parts.

Battery, ignition switch, main harness and main fuse 10A.

4th step test.

Recheck the service code indication: erase the service code, perform the pre-diagnosis inspection 1 and 2, and retrieve the service code.

If the ABS indicator light lit, faulty ECU in the ABS hydraulic unit. Replace the ABS hydraulic unit.

If the ABS indicator light unlit, ABS system is normal.

Power Supply Voltage Abnormal (over-voltage) (service code 53)

1st step test.

Disconnect the ABS diagnosis connector and ABS hydraulic unit connector.

Check for continuity for the black lead terminal of the main harness side connector.

2nd step test.

Connect the ABS diagnosis connector and ABS hydraulic unit connector.

Check the battery terminal voltage, connect the diagnosis tool to the ABS diagnosis connector.

Turn the ignition switch ON.

Battery terminal voltage

Standard: 16.6V or less

3rd step test.

Inspect the following parts.

Battery, ignition switch, main harness and main fuse 10A

4th step test.

Recheck the service code indication; erase the service code, perform the pre-diagnosis inspection 1 and 2, and retrieve the service code.

If the ABS indicator light lit, faulty ECU in the ABS hydraulic unit. Replace the ABS hydraulic unit.

If the ABS indicator light unlit. ABS system is normal.

ECU Inspection (service code 55)

1st step test.

Recheck the service code indication; erase the service code, perform the pre-diagnosis inspection 1 and 2, and retrieve the service code.

If the ABS indicator light lit, faulty ECU in the ABS hydraulic unit. Replace the ABS hydraulic unit.

If the ABS indicator light unlit, ABS system is normal.

ABS Diagnostic Tool



Connect the diagnostic tool and set the ECU to the ABS.



Check and clear the ABS DTCs in the same manner as the fuel injection DTCs.

Bosch ABS9m DTC LIST		
Code NO (Diagnostic Tool 3620A-LEB2-E00)	DTC (PDA)	description
01	5013	Rear Inlet Valve malfunction (EV)
02	5014	Rear Outlet Valve malfunction (AV)
03	5017	Front Inlet Valve malfunction (EV)
04	5018	Front Outlet Valve malfunction (AV)
05	5019	Valve Relay malfunction (Failsafe relay)
06	5025	Deviation between Wheel speeds (WSS_GENERIC)
07	5035	Pump Motor Malfunction
08	5042	Front wheel speed sensor malfunction-Plausibility
09	5043	Front wheel speed sensor Disconnection/gnd Short/Battery Voltage Short
10	5044	Rear wheel speed sensor malfunction - Plausibility
11	5045	Rear wheel speed sensor Disconnection/gnd Short/Battery Voltage Short
12	5052	Power Supply Malfunction (Under Voltage)
13	5053	Power Supply Malfunction (Over Voltage)
14	5055	ECU malfunction



When using the DATA Analyze feature of the diagnostic tool with the ABS system the front and rear wheel speed sensors should show speed when the wheels are rotated.

Inspect the wheel speed sensors, rotors, wires, and connectors if the speed doesn't show correctly.



Check the speed sensor to rotor clearance with a feeler gauge and make sure that it is 0.3 - 1.2 mm (0.0012 - 0.048 in).

ABS Unit



Note the markings on the ABS unit for the brake Front (F) and Rear (R) brake hose positions.

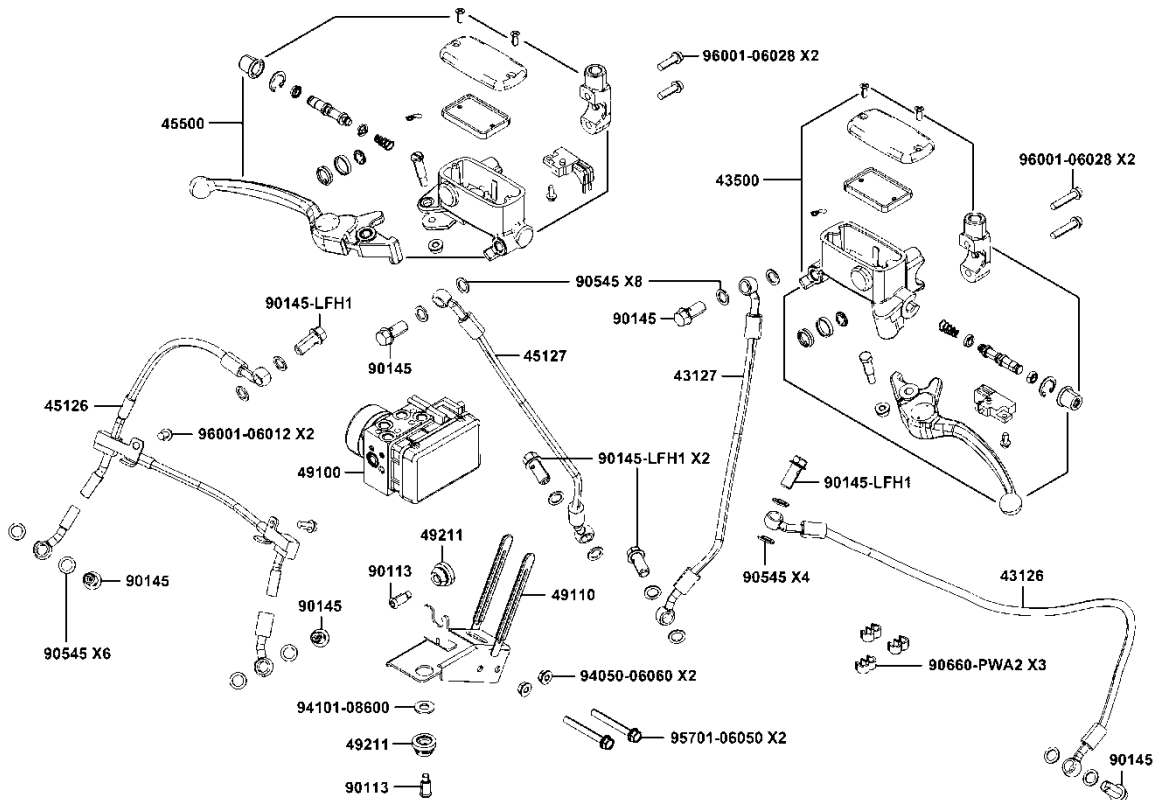

Do not attempt to disassemble the ABS unit.

If the ABS unit must be replaced the new unit should come filled with brake fluid. Install the new component immediately so that the brake fluid doesn't drain out.

11.Steering

This chapter covers the location and servicing of the steering components for the KYMCO XCITING 400i/XCITING S 400 model.

TROUBLESHOOTING	11-1
Handlebar	11-2
Switch Housings and Throttle	11-3
Grips	11-6
Steering stem	11-7

TROUBLESHOOTING

Hard steering (heavy)

- Excessively tightened steering stem top cone race
- Broken steering balls
- Insufficient tire pressure

Steers to one side or does not track straight

- Uneven front shock absorbers
- Bent front fork
- Bent front axle or uneven tire

Handlebar

SAFETY FIRST: Protective gloves and eyewear are recommended at this point.

Removal

Bar Ends

Remove the bar ends with a 6 mm Allen.



XCITING 400i



XCITING S 400

Switch Housings

Remove the wire and cable guide bolts with an 8 mm socket.

Remove the wire and cable guide from the back of the upper fork clamp.



XCITING 400i



XCITING S 400

Switch Housings and Throttle

Unplug the black connector for the left handlebar switches.

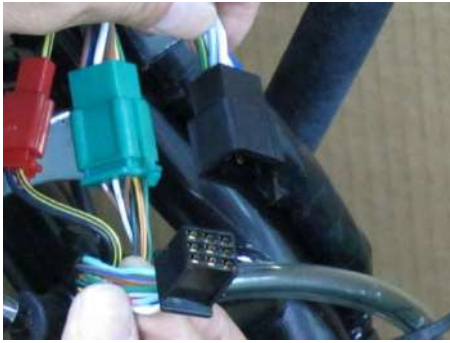

XCITING 400i



XCITING S 400

Unplug the green connectors for the right handlebar switches.



XCITING 400i



XCITING S 400

Remove the right switch housing mounting screws with a #2 Phillips screwdriver.



XCITING 400i



XCITING S 400

Separate the switch housing. The right switch housing has wires on both sides so it cannot be completely opened.



XCITING 400i



XCITING S 400

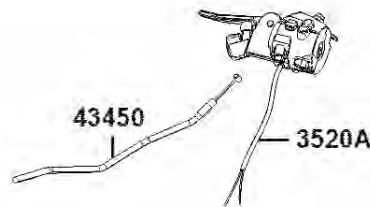
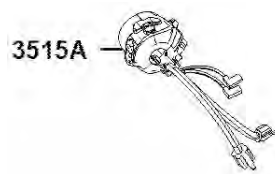

Handlebar

SAFETY FIRST: Protective gloves and eyewear are recommended at this point.



Loosen the four handlebar bolts with a 12 mm socket. Remove the handlebar holders and bolts.



XCITING 400i

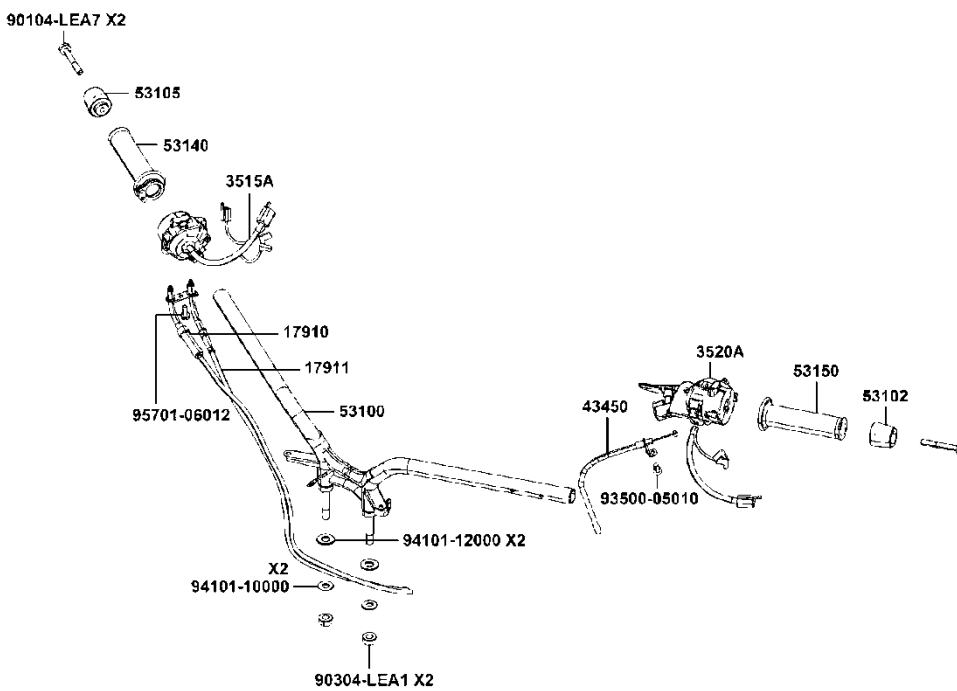

XCITING S 400

Grips



If you plan to replace the grips you can slice them lengthwise with a razor blade and peel them off. To remove the grips without cutting them use a screwdriver to open a gap between the grip and the handlebar. Spray in contact cleaner to break up the grip cement. Use compressed air to expand the grip so it can be easily slid off the end of the handlebar. Note the relationship between the angle of the grip and the throttle tube so that the new grip can be installed with the correct angle.

NOTE: Always wear safety glasses when using compressed air and never point it directly at yourself or anyone else.

Before installing the grips to either the throttle tube or the handlebar, wipe down the area with a brake or parts cleaner that will dry without leaving a residue. When you are sure the area is dry apply grip cement to the bar or tube. Install the left grip at an angle of your preference. Install the throttle grip onto the tube with the same angle as the original grip.

Steering Stem Removal

SAFETY FIRST: Protective gloves and eyewear are recommended at this point.

Support the vehicle with a suitable stand or jack so that the front wheel is off the ground. Grip the bottom of the fork legs and turn the front end side-to-side. If the movement is rough the bearings should be greased or replaced. If the movement is too tight or loose the steering stem adjusting nut may need to be adjusted.

The KYMCO XCITING 400i/XCITING S 400 use ball bearings in the steering. Always replace the races at the same time as the bearings.

Remove these components	
Windshield	Windshield
Front Cover	Front Cover
Handlebar Covers	Handlebar Covers
Handlebar	Handlebar
Center Cover	Center Cover
Front Fork	Front Fork Removal and Installation

Remove the brake hose bracket on the left side of the lower fork clamp with an 8 mm socket. Remove the upper brake hose bracket bolts. Remove the upper brake hose bracket from the upper fork clamp. Loosen the bridge stem nut with the special long socket wrench.



XCITING 400i



XCITING S 400

Remove the bridge stem nut and washer.

Lift off the upper fork clamp.

Special tool: A120F00002



XCITING 400i

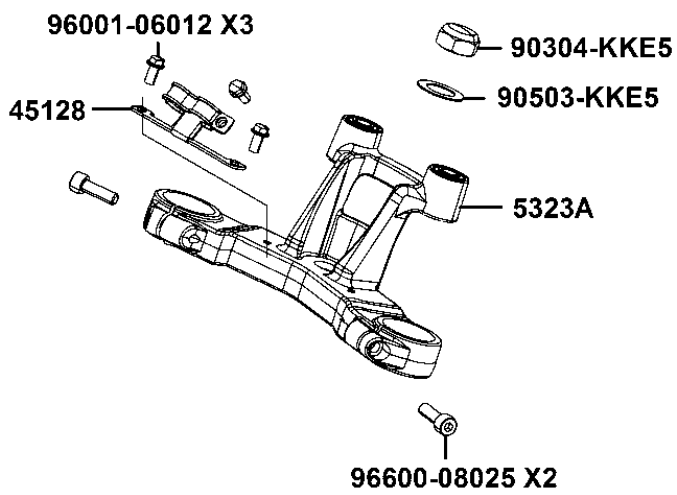

XCITING S 400

A special lock nut wrench is needed to loosen the steering stem lock nut. Remove the steering stem lock nut. Special Tool - Long Socket Wrench: A120F00007



A special lock nut wrench is needed to loosen the steering stem lock nut. Remove the steering stem lock nut. Special Tool - Long Socket Wrench: A120F00007



Slide off the lock washer. Loosen the steering stem adjusting nut with the special tool or a pin spanner. Special Tool - Steering Stem Top Thread Wrench: A120F00023



XCITING 400i

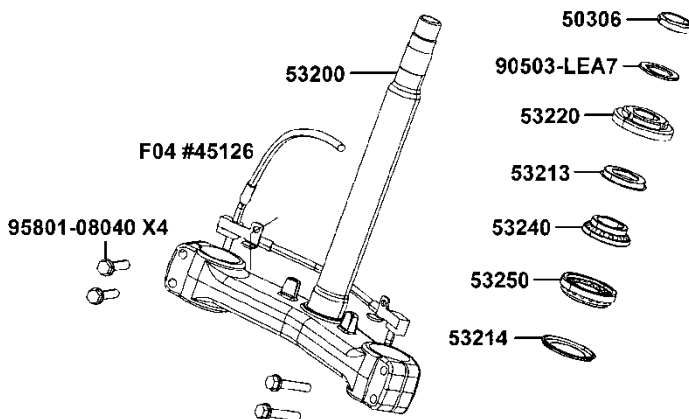

XCITING S 400

Remove the inner race for the upper bearing. Lower the lower fork clamp and steering stem out of the frame.



Lift out the upper ball bearings. And slide the lower ball bearings up and off of the steering stem.



XCITING 400i

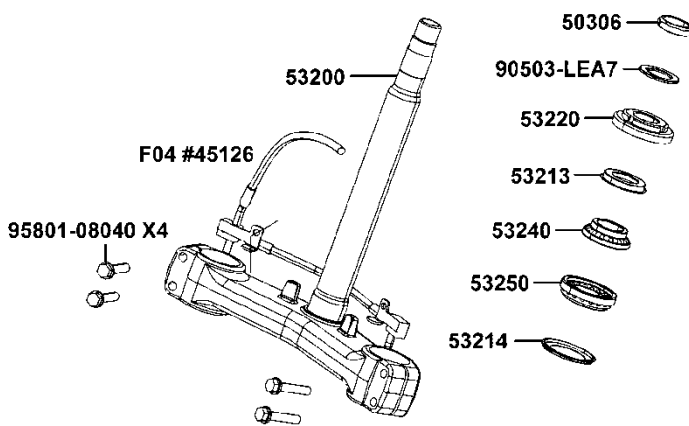

XCITING S 400



Inspect the bearings and races for wear and damage.
Replace them as needed.



Use a chisel and hammer to drive out the bearing races. Do not damage the frame pipe and steering stem. Have the drift set against the lip of the race, and work around the race evenly to drive it out. Repeat the process with the remaining bearing race.

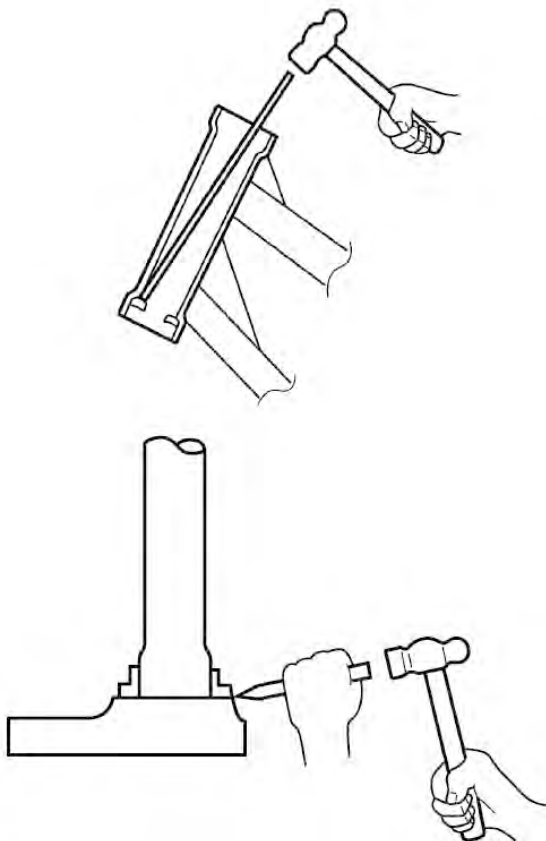

12.Front Suspension

This chapter covers the location and servicing of the front fork components for the KYMCO XCITING S 400 model.

TROUBLESHOOTING	12-1
Front Fender Assy. Removal	12-2
Front Fork Removal	12-3

TROUBLESHOOTING

Soft front shock absorber

- Weak shock springs
- Insufficient damper oil

Front shock absorber noise

- Slider bending
- Loose fork fasteners
- Lack of lubrication

Front Fender Assy. Removal

Remove the bolts, plates and reflectors.
Remove the front fender assembly.

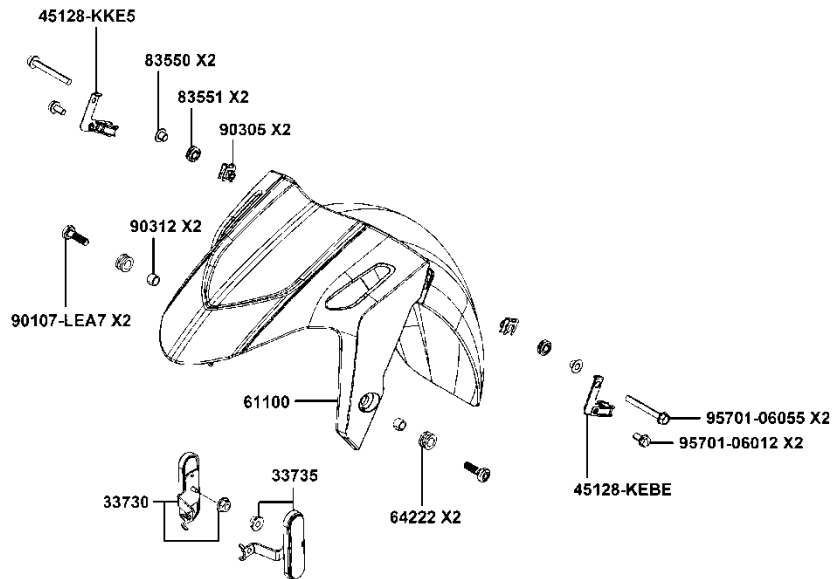

Front Fork Removal

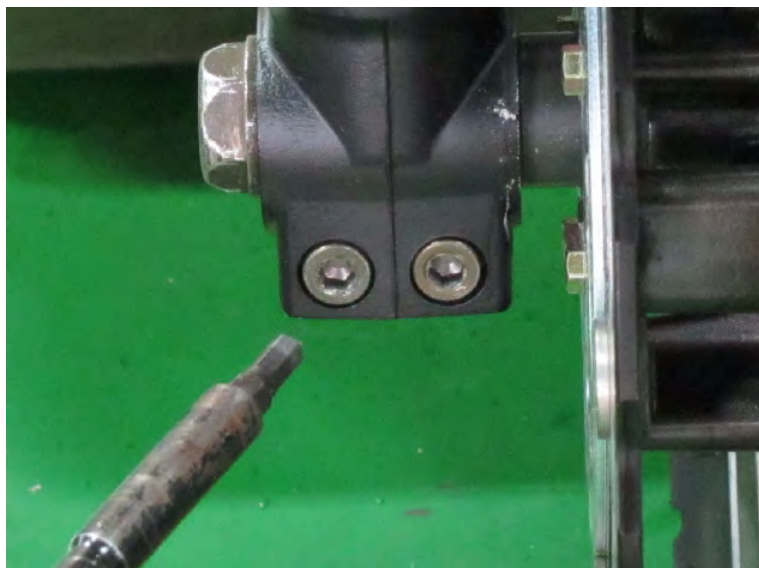

Loosen the front axle pinch bolt with a 6 mm Allen.

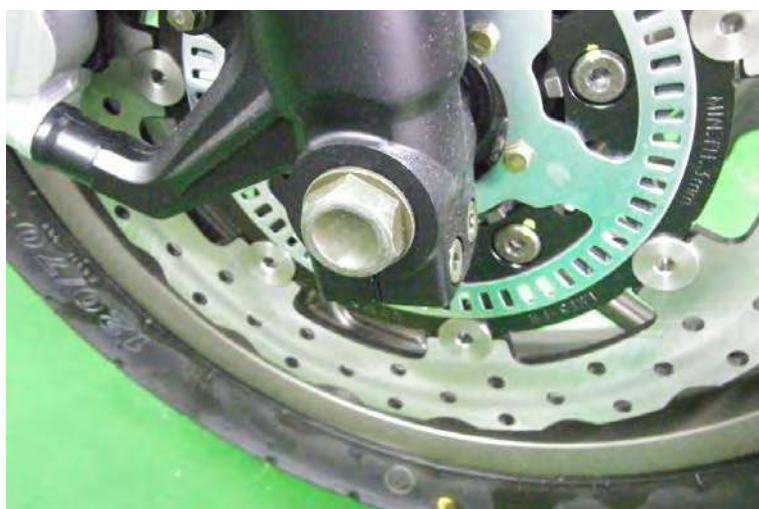

Loosen the front axle with an 24 mm socket.

Lift the front end of the vehicle with a suitable stand or jack so that the front wheel comes off of the ground.



Support the front wheel and slide the front axle out from the left side.



Guide the front wheel out from the fork legs.



Remove the collars from each side of the wheel. Inspect the bearing seals and the O-rings seals on the collars. Replace the seals if they are in poor condition.

Front Fork Removal and Installation

SAFETY FIRST: Protective gloves and eyewear are recommended at this point.

Removal

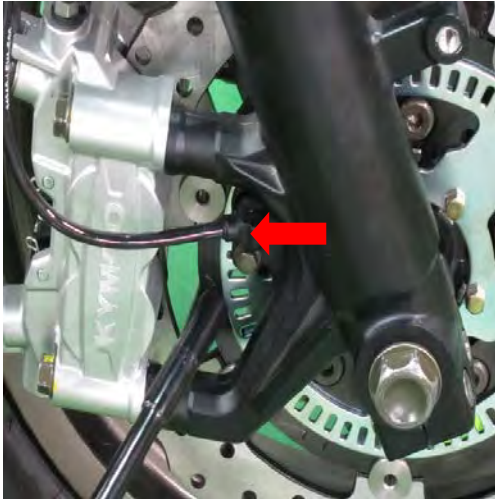

Remove the front wheel speed sensor mounting bolt with an 8 mm socket. Free the front wheel speed sensor from the right fork.



Loosen the top fork clamp bolts with a 6 mm Allen. If the fork is to be disassembled go ahead and loosen the fork caps with a 30 mm socket.



Loosen the lower fork clamp pinch bolts with a 12 mm socket. The top bolts must be removed.



Slide the forks legs down and out of the fork clamp using a twisting motion.

Installation



Slide the fork legs up into fork clamp using a twisting motion.



Fit the fork into place so that the mark on the top of the fork tube lines up with the upper fork clamp as shown.

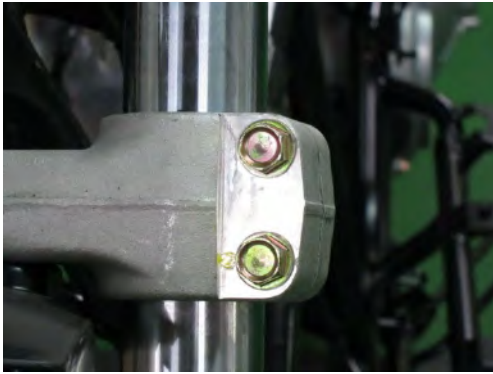

Tighten the lower fork clamp bolts evenly to specification with a 12 mm socket.

Item	Q'ty	Thread dia.(mm)	Torque
			Nm (kgf-m, ft-lb)
Lower pinch bolt	4	8	32 (3.2, 23)



Tighten the fork caps securely with a 30 mm socket. Tighten the upper fork clamp bolts to specification with a 6 mm Allen socket.

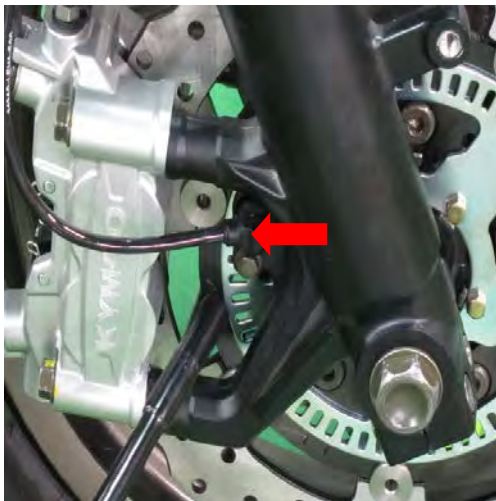

Install the speed sensor and its mounting bolt to the right fork leg. Tighten it securely with an 8 mm socket.



Check the speed sensor to rotor clearance with a feeler gauge and make sure that it is 0.3 - 1.2 mm (0.0012 - 0.048 in).

13.Rear Suspension

This chapter provides information on the rear suspension components of the KYMCO XCITING 400i/XCITING S 400 model.

TROUBLESHOOTING	13-1
Rear Fork	13-2
Installation	13-6
Shock Absorbers.....	13-8

TROUBLESHOOTING

Soft rear cushion

- Weak shock absorber spring
- Damper oil leaks

Rear Fork

SAFETY FIRST: Protective gloves and eyewear are recommended at this point.

Removal

- When performing the services stated in this section, the engine and exhaust muffler must be cold to avoid scalding.
- During servicing, keep oil or grease off the brake pads and brake disk.

Remove these components	
Muffler	Exhaust System
Right Rear Shock Absorber Lower Mount	Shock Absorbers



Hold the rear brake to keep the rear wheel from turning.



Remove the rear axle nut with a 27 mm socket.



Remove the rear wheel hose clamp bolts with an 8 mm socket.

Place the scooter on its center stand so that the rear wheel is off the ground.

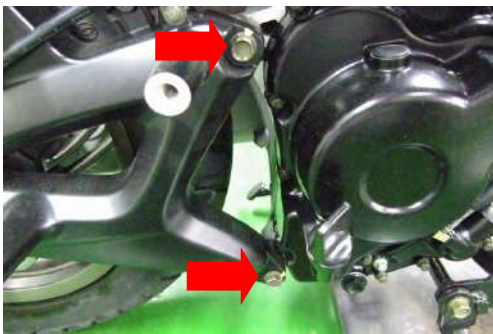

Remove the two rear fork bolts with a 12 mm socket.



Remove the rear fork.



Remove the collar from the rear fork.



Inspect the wheel bearing by turning it with a finger. Replace the bearing and seal as needed.



Remove the seal and snap ring.



Drive the bearing out from the inside out.



Drive in the new bearing with a suitable driver that is the same outside diameter as the bearing.



Install the snap ring into the groove.



Apply grease to the lips of the new seal and drive it into place in the same manner as the bearing.



Inspect the shock absorber bushing and replace it as needed.
Inspect the rear fork for damage and replace it as needed.

Installation



Apply grease to the lips of the dust seal and install the collar into the rear fork.



Fit the rear fork into place.

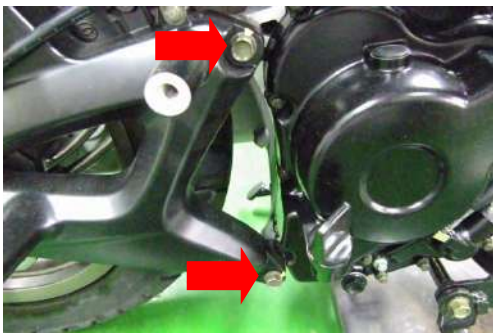

Install the two rear fork bolts and tighten them to specification with a 12 mm socket.

Item	Q'ty	Thread dia.(mm)	Torque
			Nm (kgf-m, ft-lb)
Rear fork	2	8	35 (3.5, 25)



Install the rear wheel speed sensor and hose clamp bolts with an 8 mm socket.



Install the rear axle nut and tighten it to specification with a 24 mm socket.

Item	Q'ty	Thread dia.(mm)	Torque
			Nm (kgf-m, ft-lb)
Rear axle nut	1	16	140 (14, 100.8)

Shock Absorbers

SAFETY FIRST: Protective gloves and eyewear are recommended at this point.

Pre-Load Setting

Each shock absorber on the scooter has 5 spring preload adjustment positions for different load or riding conditions.

Position 1 is for light loads and smooth road conditions. Position 3 to 5 increase spring preload for stiffer rear suspension and can be used when the scooters heavily loaded. Be certain to adjust both shock absorbers to the same spring preload positions.

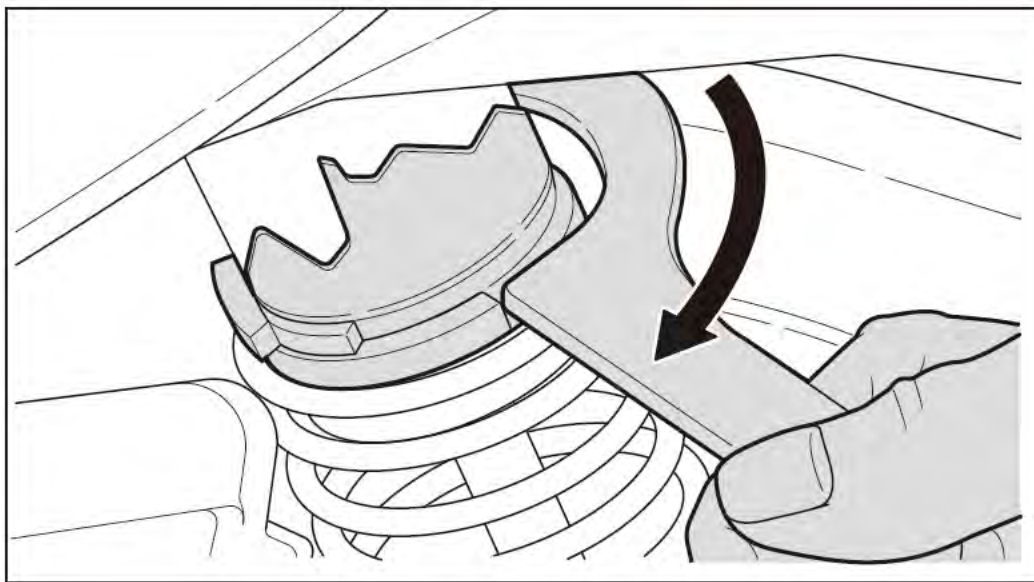

Use a pin spanner to adjust the rear shock spring preload. The shock absorbers are adjustable for pre-load. There are 5 settings. Position 1 is the softest and 5 is the stiffest.

Caution: Always adjust the shock absorber pre-load position in sequence (1-2-3-4-5 or 5-4-3-2-1). Attempting to adjust directly from 1 to 5 or 5 to 1 may damage the shock absorber.

(Pre-Load Standard Setting: Position 3)

Removal

Place the vehicle on its center stand.

Remove these components	
Seat	Seat
Luggage Box	Luggage Box

Support the engine with a suitable hoist or jack.



Remove the rear shock mounting bolts with a 14 mm socket.



Remove the shock absorbers.



Inspect the shock absorber bushings for wear and damage.

Replace the shock absorbers or bushings as needed.



Check over the shock absorber for damage and oil leaks. Replace the shock absorber if needed. Do not attempt to disassemble the shock absorber.

Installation



Fit the shock absorber into place. Make sure the preload arrow indicator faces out from the lower mount.



Install the upper shock absorbers. Insert the upper mounting bolt first. Tighten the bolts to specification with a 14 mm socket.

Item	Q'ty	Thread dia.(mm)	Torque
			Nm (kgf-m, ft-lb)
Rear shock absorber bolt	4	10	40 (4, 29)



Install the lower shock absorber mounting bolts and torque them to specification with a 14 mm socket.

Item	Q'ty	Thread dia.(mm)	Torque
			Nm (kgf-m, ft-lb)
Rear shock absorber bolt	4	10	40 (4, 29)

Remove these components	
Luggage Box	Luggage Box
Seat	Seat

14.Wheels

This chapter covers the location and servicing of the wheels for the KYMCO XCITING S 400 model.

Troubleshooting	14-1
Wheel Bearing Replacement	14-2
Front Wheel	14-5
Tire Inspection	14-10
Wheel Inspection	14-22

Troubleshooting

Front wheel wobbling

- Bent rim
- Loose front axle
- Faulty tire
- Improperly tightened axle nut

Rear wheel wobbling

- Bent rim
- Faulty tire
- Axle not tightened properly

Rear wheel noise

- Worn rear wheel axle bearings
- Worn rear fork bearings
- Deformed rear fork

Wheel Bearing Replacement

SAFETY FIRST: Protective gloves and eyewear are recommended at this point.

Replace bearings as a set, and do not reuse old bearings.

Place the new bearings in the freezer about an hour before you plan to install them.

Do not let the wheel rest on its brake discs or wheel speed sensor rotor.

Front Wheel



Remove the dust seals from the each side of the front wheel using a seal pick or large flat blade screwdriver. Discard the dust seal, it should be replaced by a new item.



Inspect the wheel bearings by turning them in the hub. If the bearings have excessive play in them or are rough replace all the bearings for that wheel.



Remove one of the bearings with a bearing puller.
Special Tools- Bearing Remover: A120E00093



Remove the distance collar.



Repeat the procedure and remove the other bearing and seal.
The seal should be replaced with a new item.

Install the left bearing first. Pack the new bearing cavities with grease.



Heat the bearing area of the wheel with a heat gun, take the bearing out of the freezer and install it. You can use a bearing installer tool or a socket with the same outside diameter as the bearing. Make sure the bearing is fully seated and the marked side is facing out.

Special Tools-Bearing Installer: A120E00014

Insert the distance collar into the hub.



Drive in the other bearing. The bearing should fit against the distance collar. Do not continue to force the bearing in or the distance collar will begin to push the right bearing back out.



Apply grease to the lips of the dust seals. Drive in new dust seals. Use a suitable driver that has the same outside diameter as the seal. The dust seals should be flush with the wheel hub.

Front Wheel

SAFETY FIRST: Protective gloves and eyewear are recommended at this point.

Removal

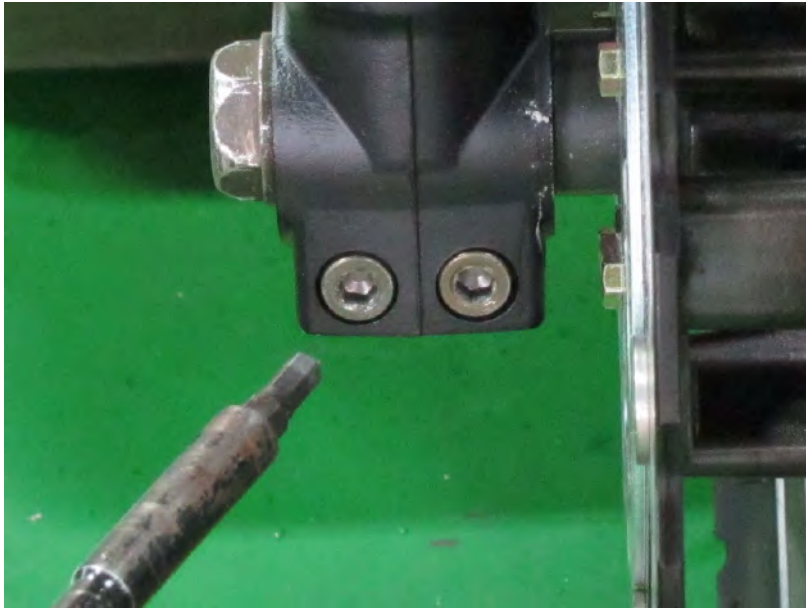

Loosen the front axle pinch bolt with a 6 mm Allen.

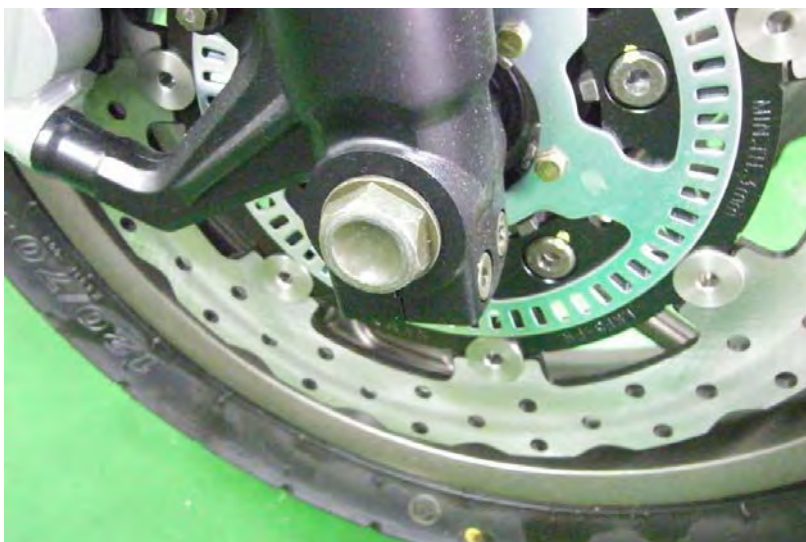

Loosen the front axle with an 24 mm socket.

Lift the front end of the vehicle with a suitable stand or jack so that the front wheel comes off of the ground.



Support the front wheel and slide the front axle out from the left side.



Guide the front wheel out from the fork legs.



Remove the collars from each side of the wheel. Inspect the bearing seals and the O-rings seals on the collars. Replace the seals if they are in poor condition.

Inspect the wheel bearings by turning them in the hub. If the bearings have play in them or are rough replace all the bearings for that wheel.



To remove the speed sensor rotor take out the five bolts.

Installation



Install the front wheel speed sensor rotor. Tighten the five bolts securely.



Apply grease to the lips of the dust seals and collar O-rings. Insert the collars into the hub as shown.



Make sure the tire direction of rotation marker is correct.

Slide the front wheel into the fork.



Apply a light coat of grease to the front axle. Insert the axle from the left side. Set the front wheel on the ground. Pump the front suspension up and down several times to seat the front axle



Tighten the front axle to specification with an 24 mm socket.

Item	Q'ty	Thread dia.(mm)	Torque
			Nm (kgf-m, ft-lb)
Front axle bolt	1	14	20 (2, 15)

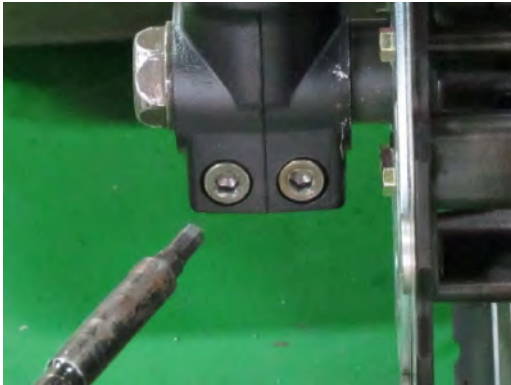

Tighten the front axle pinch bolt securely with a 6 mm Allen.

Item	Q'ty	Thread dia.(mm)	Torque
			Nm (kgf-m, ft-lb)
Front fork pinch bolt	2	8	23 (2.3, 17)

Pump the front brake lever to establish pressure and to seat the pads against the disc. If the brakes do not pump up correctly check the brake fluid.

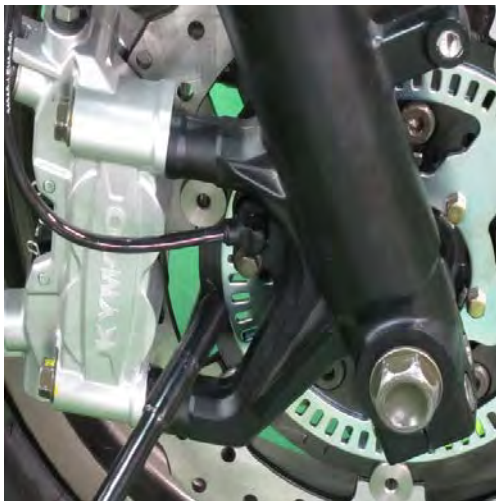

Check the speed sensor to rotor clearance with a feeler gauge and make sure that it is 0.3 - 1.2 mm (0.0012 - 0.048 in).

Check grip between tire and ground and a normal tire pressure.

In case of a gripping anomaly, check tire pressure for normal reading using a pressure gauge.

Pressure measurements of cool tire:

With 1 rider

Front Wheel 2.0 kgf/cm² Rear Wheel 2.25 kgf/cm²

With 2 persons

Front Wheel 2.0 kgf/cm² Rear Wheel 2.25 kgf/cm²

Measure pattern depth at center of tread pattern. Measurements shall be taken at several points due to uneven wear.

Replace the tire if any of the measurements is lower than the service limit. Make sure the wheel is properly balanced when a new tire is replaced.

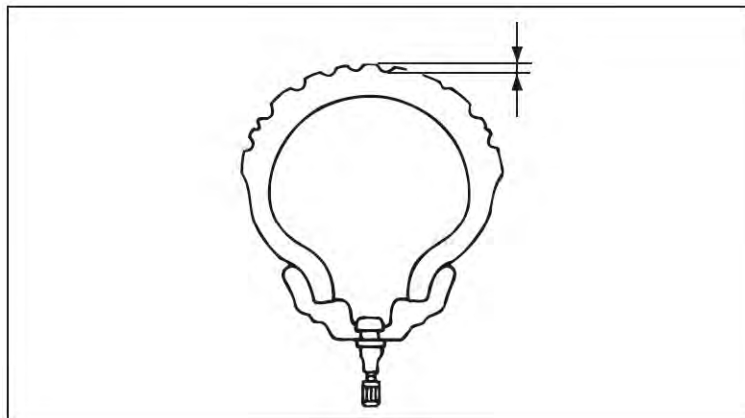
**Service Limits:**

Front Wheel 1.6 mm

Rear Wheel 2.0 mm

Check Tread Pattern for Wear

Check tires before each riding. In case of finding a transverse line (minimum pattern depth), nail or glass chip on the tire, or crack line on the side wall of tire, go to Kymco dealer for replacing with new one. Excessive wear of tire tread pattern will result in widened tread which is more prone to be punctured.

Tire Dimensions:

Front Tire Dimensions: 120/70-R15

Rear Tire Dimensions: 150/70-R14

Wheel Inspection

SAFETY FIRST: Protective gloves and eyewear are recommended at this point.

Turn the inner race of each bearing with your finger to see if they turn smoothly and quietly. Also check if the outer race fits tightly in the hub. Replace the bearings if the races do not turn smoothly, quietly, or if they fit loosely in the hub. See the Wheel Bearing Replacement topic for more information.



Place the wheel on a truing stand and use a dial indicator to check if the rim is out of true. The specifications for the front and rear wheels are the same. Check for lateral wobble. The service limit is 2.0 mm (0.08 in) or less.



Check for radial hop. The service limit is 2.0 mm (0.08 in) or less.



Check the front axle runout. The axle runout specification is half of the total indicator reading. Replace the axle if the measurement exceeds 0.2 mm or 0.008 in.

Inspect the dust seals and replace them as needed.

15.EEC SYSTEM

This chapter covers the E.E.C system for the KYMCO XCITING S 400.

E.E.C System Introduction	15-2
Function	15-3
Trouble Shooting	15-3
Air Filter Servicing	15-4
Maintenance Information	15-5
Dismantle Of Canister	15-6
Oxygen Sensor	15-9

WARNING:

- Before running the engine, make sure that the working area is well ventilated. Never run the engine in a closed area. The exhaust contains poisonous carbon monoxide gas, which may cause death to people.
- Gasoline is extremely flammable and is explosive under some conditions. The working area must be well ventilated and do not smoke or allow flames or sparks near the working area or fuel storage area.

E.E.C System Introduction:

Evaporative Emission Control System

The evaporative emission control system is used to prevent gasoline vapors from escaping into the atmosphere from the fuel tank and fuel system.

Crankcase Emission Control System

The scooter is equipped with a closed crankcase system. Blow-by gas is recycled into the combustion chamber via the intake system. This arrangement is to prevent blow-by gas from spreading to the atmosphere.

Exhaust Emission Control System

The exhaust emission from the scooter is controlled by combustion management, fuel delivery, ignition setting and exhaust system. The exhaust system also includes the catalytic converter in the muffler.

Noise Exhaust Emission Control System

The engine, intake and exhaust systems of the scooter are designed to comply with federal or local noise regulations. Do not modify the intake or exhaust system, this behavior will offend against the noise regulations.

Note: Do not adapt any original factory design and setting, which will deteriorate the sound or emission level.

Function

Item	Function	Description
Evaporative Emission Control Valve	It is used to prevent gasoline vapors from escaping into the atmosphere from the fuel tank and fuel system.	Storage the gasoline vapors to canister, conduct the gasoline vapors to engine by vacuum when starting the engine.
Canister	Storage the gasoline vapors from fuel tank and fuel system.	The gasoline vapors storage by canister, to meet the regulation, the HC emission can not exceed 2 grams.
P.C.V	Recycle the fuel gas from the crankcase blow by.	Recycle the fuel gas from the crankcase blow by to the engine.
Oxygen Sensor	To control the air/fuel mixture in best condition.	Sending the mixture condition info to ECU by voltage signal, ECU control the fuel injection to meet the emission regulation.
Catalyst	To reduce the emission of HC, CO and NOx produced from the exhaust gas.	Using the catalyst convert the HC and CO to oxygen and reduce the NOx pollution.
ECU	To control the injector, ignition and bypass air of fuel injection system to reach the best driving condition.	ECU (Electric Control Unit), receiving sensor which equipped on engine to precisely control fuel injection and ignition to reduce the exhaust emission pollution.

Trouble Shooting

Low engine power, instable engine idle speed

- Clog in canister or tubes.
- Emission control valve malfunction.
- E.E.C. system tubes loosen or crack.
- ECU malfunction.

Engine idle speed and acceleration in bad condition

- Clog in canister or tubes.
- Emission control valve malfunction.

Air Filter Servicing

SAFETY FIRST: Protective gloves and eyewear are recommended at this point.

Replace the air filter according to the Maintenance Schedule, and more often in exceptionally rainy or dusty areas.

Air cleaner element replacement

Remove bolts from the air cleaner element set , then remove and discard this air cleaner element.

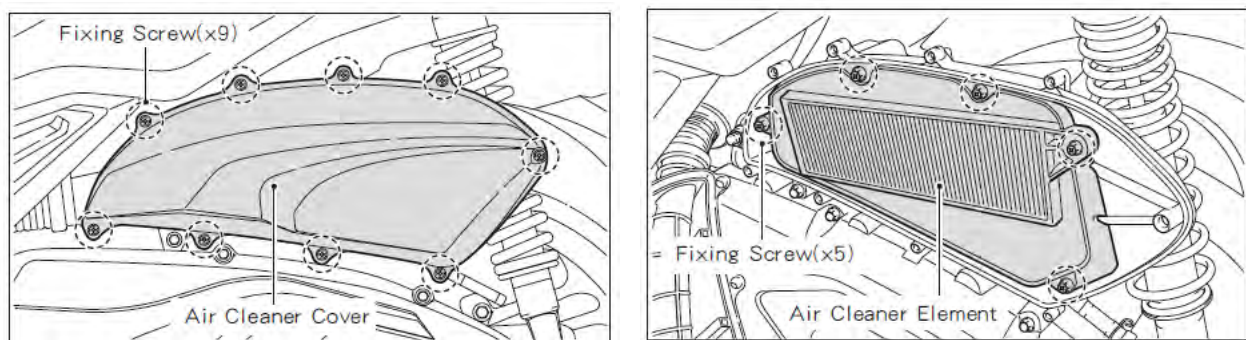

The new air cleaner element set installation is in the reverse order of removal.

Use the KYMCO genuine air cleaner element or an equivalent air cleaner element specified for your model. Using the wrong KYMCO air cleaner element or a non-KYMCO air cleaner element which is not of equivalent quality may cause premature engine wear or performance problems..

Remove the air filter from the airbox. Discard the air filter in favor of a new item.

Caution:

- The air cleaner element has a viscous type paper element. Do not clean it with compressed air.
- Be sure to install the air cleaner element and cover securely.

Maintenance Information

Note of maintenance:

- Install the tubes in correct position.
- If the tubes broken should be replaced with a new one.
- The tubes should be installed tightly.
- The leakage hole should be installed downward.

Tool

- Vacuum pump
- Pressure pump

Maintenance standard

- Emission vacuum standard: 45m/mHg
- Capacity of canister: 90cc
- Install angle: incline 60°

Evaporative Emission Control System

The location of tube connection diagram.

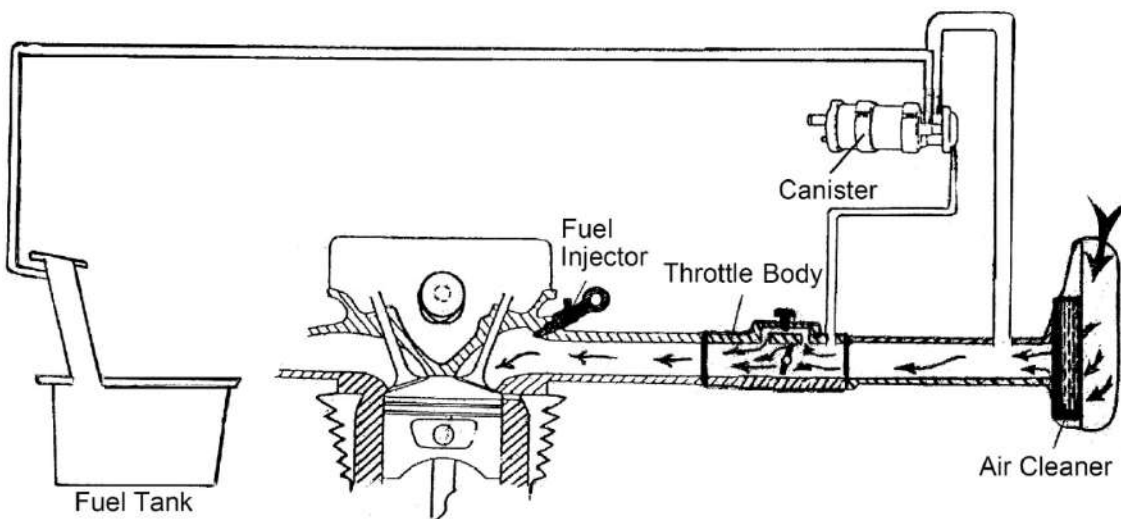

Leakage checking

1. Connection between canister and fuel tank.
2. Tubes of canister.

Dismantle of Canister

- 1.Dismantle the windshield, front cover and head light assembly.
- 2.Dismantle the canister tube set and canister.



Canister

Inspection of canister evaporative control valve

Connecting a vacuum pump to the tube of canister. (Follow the illustration below.)

Applying 250m/mHg pressure to the canister evaporative control valve.

If the pressure will be kept without change obviously in one minute, that means the valve are with good condition, otherwise the valve malfunction, a new canister should be replaced.

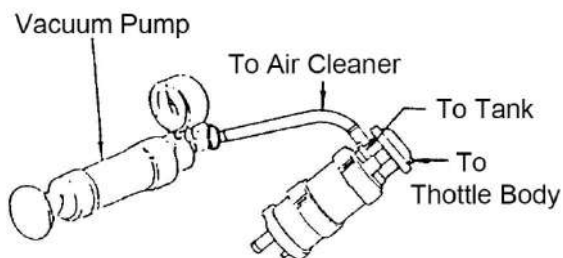

Connecting a vacuum pump to the tube of canister. (Follow the illustration below.)

Applying 45m/mHg vacuum pressure to the canister evaporative control valve.

If the pressure will be kept without change obviously in one minute, that means the valve are with good condition, otherwise represents the valve with malfunction. A new canister should be replaced.

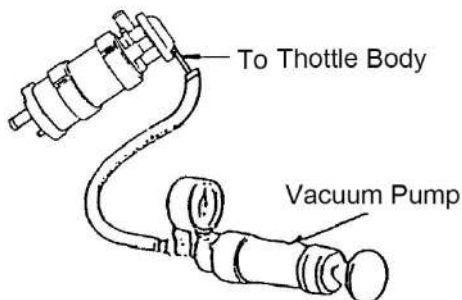

Inspection of the flow rate of the canister vacuum valve

1. Using a vacuum pump connecting to the vacuum tube of canister and apply 45m/mHg of negative pressure.
2. Apply pressure to the emission control valve of canister, if the flow rate above 9.4 liters per minute that means the valve is in good condition, otherwise the canister should be replaced.

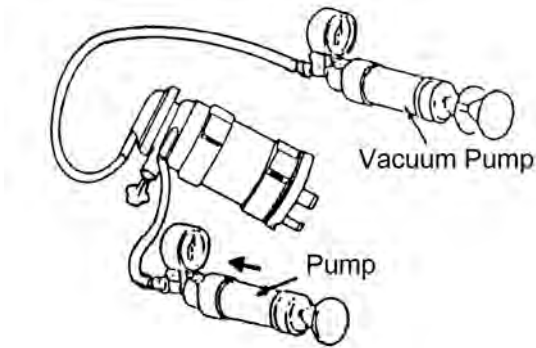

NOTE: Always using the pump by manual, do not apply high pressure for testing to prevent the valve from malfunction.

Installation of canister

1. Installation is the reverse order to the dismantling.
2. Connect the tubes and circlips firmly.

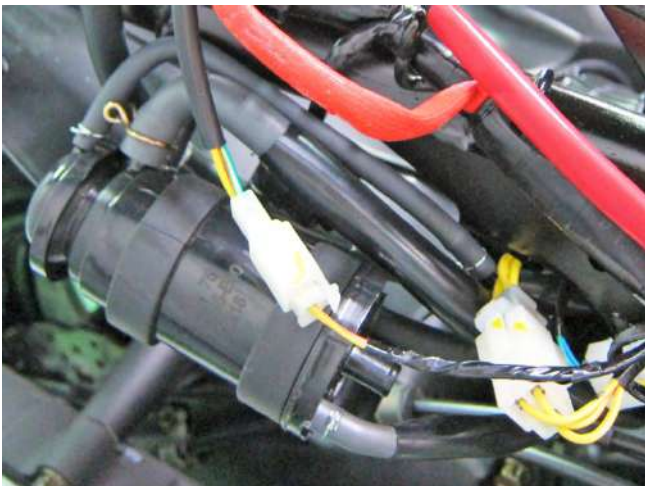

NOTE: The tube should not be wrenched or crashed and never refit the canister.

P.C.V. Dismantle

- 1.Dismantle the cover of air cleaner.
- 2.Dismantle the P.C.V cover.
- 3.P.C.V , if there is oil in the red drain tube, it should be cleaned.

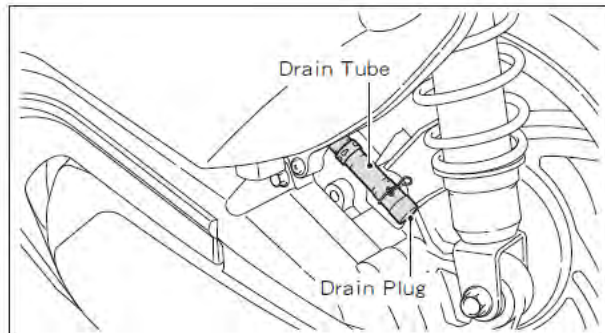

Inspection of emission system

- Clean or replace the air cleaner.
- Inspection of the spark plug.
- Inspection of the ignition system.
- Plug in the diagnostic tool the check the information.
- Warm up the engine reach above 80°C.

This model equipped the catalyst in the muffler to reduce the pollution emission.

Inspection Of Catalyst Converter

- Inspection of catalyst converter efficiency at idle speed.
- Warm up the engine 8~10 minutes, connect to emission machine.
- To check the CO value before catalyst and after.
- Normally, measuring after catalyst converting, the CO figure will be lower than the CO figure before catalyst converting.
- If the number is abnormal, the catalyst converter could be deteriorated, the exhaust pipe should be replaced to prevent from the further pollution.

Oxygen Sensor



It uses DC-8-16V Battery Power with 4 pins: one power pin, one heater pin, one signal output pin and one earthing pin. The sensor is installed to the front pipe of exhaust pipe to detect the oxygen concentration of exhaust gas for determining if ECU shall instruct to increase or reduce fuel supply for meeting waste gas emission standard of environment legislation. When the temperature of exhaust is less than 350°C , the sensing portion can not be activated and there is no signal output, and ECU will turn on the heater inside sensor to accelerate the temperature rise of sensor and cause the Oxygen Sensor to work normally. In normal hours, the impedance of heater is 7.7 ± 1.2 ohm and can be told with multimeter. Output of sensor after the engine is warmed up is
 A/F <14.7 (mixing ratio too thick) $>0.7\text{V}$
 A/F > 14.7 (Mixing ratio too thin) $<0.18\text{V}$

Inspection and adjustment of emission

1. Start the engine and warm up for several minutes engine temperature $80\sim 90^{\circ}\text{C}$, connect the diagnostic tool to check the information.
2. Idle speed should be in standard.
3. The emission machine should be connected to the front of the exhaust pipe measure hole. (Before Catalyst Converter)
4. Standard : CO: $0.3\sim 1.3\%$
5. If the figure is out of range, check with the injection relative components. (For example, injector, fuel pump...etc.)
6. If the problem insist, please check the emission related system and check if there is any leakage from the cylinder head inlet/outlet valve.