

Please read the instructions carefully before using the bike  
Do not use an e-bike until you know its performance. Please  
keep the instructions carefully

# HIMO

This product is only for sale in greater China.



# T1

Operating manual

The picture is for reference only

## Precautions for use

### Obey traffic laws and traffic safety instructions

- It is forbidden for people under 16 years old to drive on the main road;
- E-bikes shall be insect-free in the lane of the field, and the maximum speed shall not exceed 15km/h. On the road of Po si tongguo lane, one shall drive on the right side of the
- Do not lend electric bicycle can not operate the personnel to drive, in order to avoid injury
- Electric vehicles shall carry people or articles in accordance with laws and regulations
- It is recommended to wear a helmet when riding and pay attention to driving safety; it is forbidden to hold the handle with one hand and ride with both hands off the handle;

### Safety tips for using electric vehicles

- Do not park in building foyers, evacuation stairways, walkways and exits
- Do not charge and park electric vehicles in residential buildings, charging should be far away from combustible, charging time should not be too long
- Proper use and maintenance of batteries, used batteries can not be dismantled without authorization, should be organized by the relevant professional recycling
- Understand safe use of chargers and warning terms
- When replacing the charger, it should match the model of the battery
- Do not flush with water to avoid potential accidents caused by wetting of internal electronic components and wiring
- When adjusting handlebars or saddles, care shall be taken not to expose safety line marks of risers and saddles (where applicable)

### Preparation before riding

- Whether the power circuit and lighting are good.
- Whether the front and rear brake lever are good.
- Whether the handlebars and front and rear wheels are in a tight state. Whether the
- tire pressure is normal.

### Bike coding position

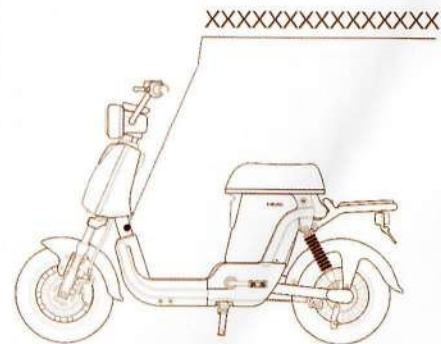

## Electrical schematic diagram

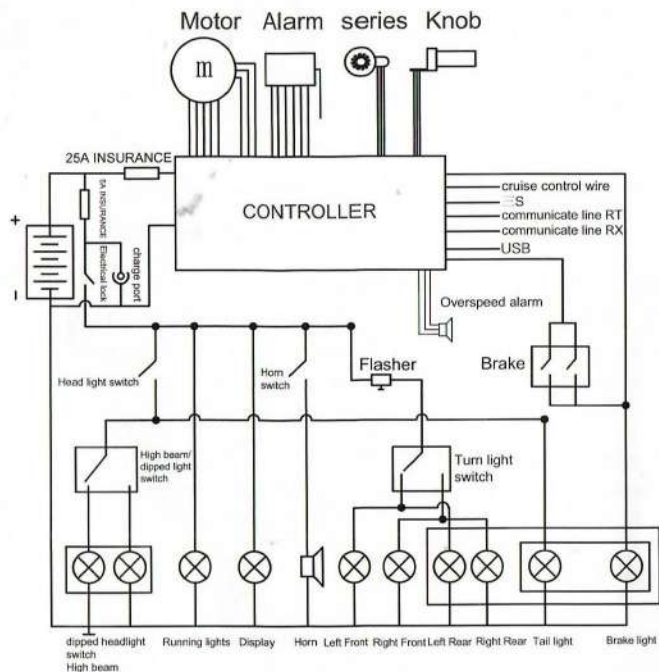

\*The discharge circuit USES 25A plug - in safety

\*The charging circuit USES 5A plug type insurance

## Bike parameters

Model	TDS17007Z
Dimensions (L*W*H)	1515 × 665 × 1065mm
Front and rear wheel center distance	1080mm
Max weight	54.8kg
Maximum design speed	25km/h
Electric range	≤60km
Consumes electricity (100KM)	1.12 kW · h/100km
Loading weight	100kg

\* Under the condition of full power, the load is 75KG, the temperature is about 25°C, the smooth road is in a non-wind environment, and the driving speed is 15KM/h under the energy saving mode. The actual driving time will not stop due to load, temperature, custom, road surface and operating habits.

## Main parameters of battery

Battery type	Lithium on battery
Capacity	14Ah
QTY	2
Nominal voltage	48V

## Maintechnical parameters of motor

Motor type	DC Motor
Motor from	The permanent magnet
Nominal power	350W
Rated speed	380r/min
The rated voltage	48V

## Main parameters of controller

Under voltage protection	40 ± 2V
Over current protection	15 ± 2A

## USB charger main parameters

The output voltage	5V
The output current	1A

## Remote control and boot device

### Introduction to remote control operation

### Remote control

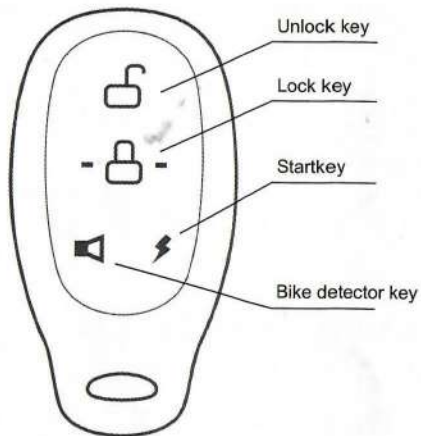

- **Unlock key:** upon receiving this key, the horn will sound twice and the alarm will be relieved.
- **Lock key:** press this key, the horn will sound, and the alarm mode will be turned on after 2 seconds.  
Alert first vibration, horn alarm 4 seconds. Wait 10 seconds to shake again will enter 15 seconds alarm.  
During the alarm process, the alarm will send a signal to inform the controller to lock the motor.
- **Search button:** pick it up gently, search mode, horn sound for 4 seconds, inform the location of the owner.  
Long press for 2 seconds, adjust the sensitivity, the horn will sound with 2, 4 cycles. One is the most sensitive, four is the dullest, five is silent anti - theft. When you hear the required level of warning sound, release the car search key, and the system will enter the alert state. (the default level of the system is level 2)
- **Start button:** the speaker will make a sound, and the whole vehicle will be connected to the power source of the electric door lock. At this time, the key can be driven without keys (it will not work if the key is turned on the electric door).

### One-click start button

- In the unstarted state, long press this button for 1 second to start the vehicle power supply.
- In the startup state, long press this button for 3 seconds to stop the power supply of the vehicle. Only 5 seconds later no action is in alert mode.



### Physical lock

ON: turn ON the power, and the whole car is powered ON  
 OFF: Power off, vehicle power off  
 LOCK: Lock on



### The lock operating

Turn the handlebars to the left to the limit, push and rotate to the LOCK gear.

Lock on: Insert the key into the physical lock and press down

Tap unlock: the key is inserted into the physical lock and rotated to the desired gear

### Start the bike



3. Long press the start and stop button for 1 second



1. Press the unlock button of the remote control



2. Tap lock open



3. Make the start button of the remote control



4. Lucky side support, press the left P switch; Instrument P light goes out



5. Turn the handle to move forward



3. Turn the physical key to ON

# Instrument panel and combination switch

## Dashboard introduction

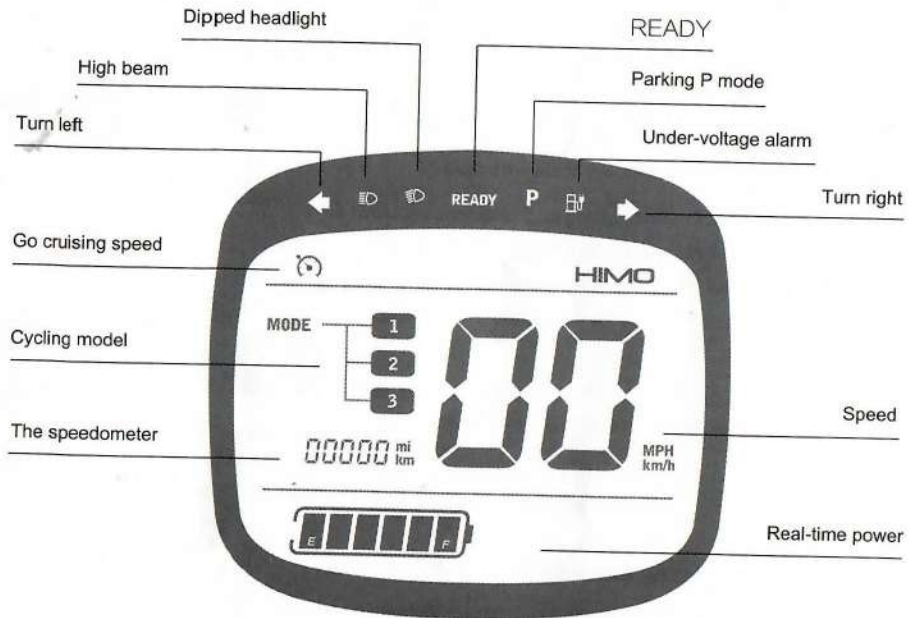

### Left hand combination switch

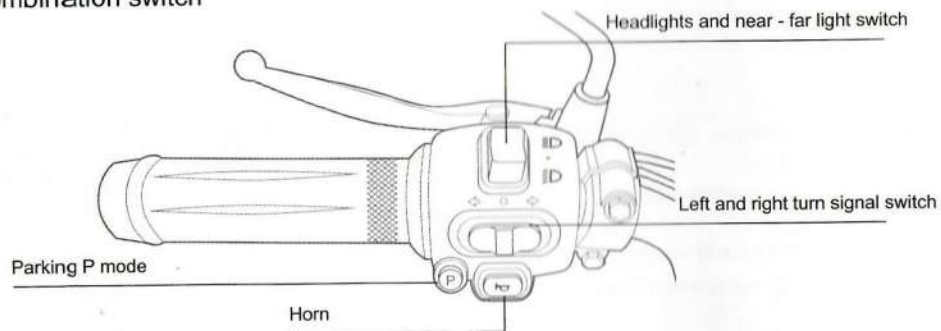

### Right hand combination switch

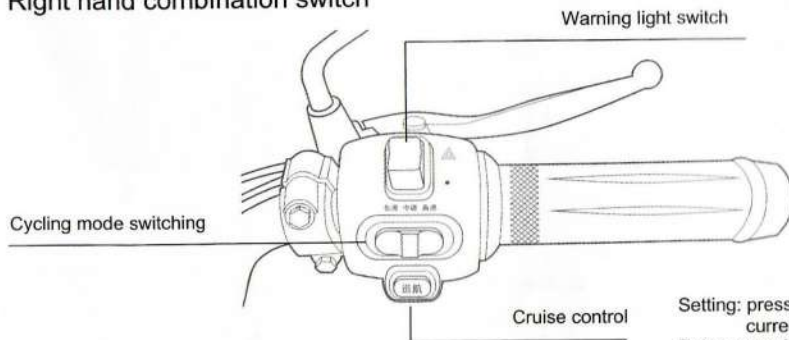

Setting: press the constant speed cruise button to maintain the current speed back to the odd line.  
Release: cruise relief is accomplished by changing the current speed by turning the handle or brake handle.

## Battery instructions

### The battery charging

- Nsert the power supply plug of the charger into the charging port of the battery, and then plug the power supply plug into the power supply
- Under charging state, the indicator light of the charger is red and green when it is fully charged
- After charging, first unplug the power plug and then unplug the charger power plug
- If the battery is charged in the car, please turn off the instrument power

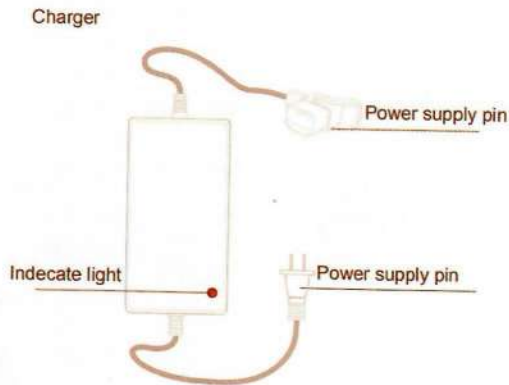

### The battery interface

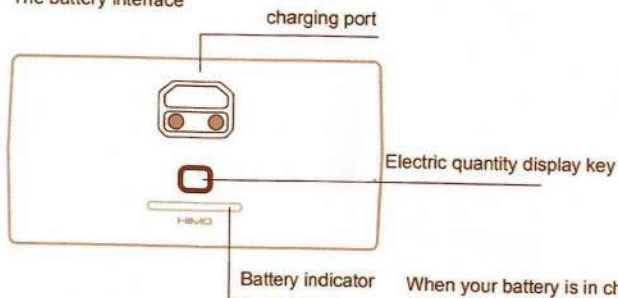

When your battery is in charging or non-charging state, the "charge" button displays the



## Battery installation

- The key opens the bucket, opens the cushion
- Insert the battery in the right direction
- Connect the power supply plug
- Cover the seat and pull out the keys

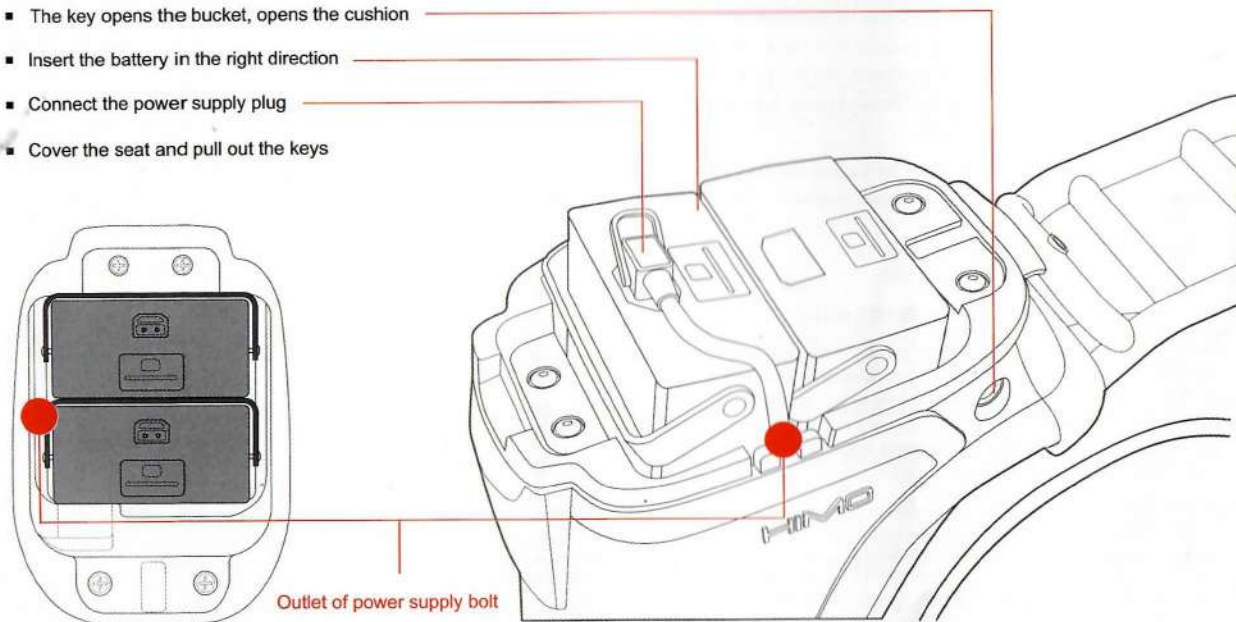

## About the battery

### Lithium batteries before use

- Before use, make sure the battery model is the original battery of the vehicle. Do not use the battery of mota brand at will.
- Check the appearance of the battery is in good condition, without any obvious phenomena such as damage, fluid leakage, heat immersion and smoke.
- In order to ensure the safety of transportation, the battery leaves the factory with a power of about 30%. Due to the self-consumption of transportation and storage cycle, the battery is low or no power in the first use. This is a normal phenomenon, so please do not worry.
- Please charge the battery for 24 hours for the first use after purchase or long-term storage. During normal use, charge the battery for 24

### Using the environment

- The optimum operating environment is 10 C-45 C
- Under the low temperature zone, the available capacity of lithium battery will decay to different degrees. The specific reference degree is as follows: Available capacity at -10 C is about 70%. Available capacity at 0 C is about 85%. Available capacity at 25 C is about 100%. If the battery has any oddness, heat, deformation or other abnormal conditions, please immediately stop using, stay away from the battery and contact the after-sales department.

## Warning

The battery is not a part that can be repaired by users. In case of any abnormal phenomenon, please contact the after-sale department for maintenance.  
Disassembling the battery will not be covered by the three-pack policy, and may cause the battery to generate heat, smoke, fire, or explosion.

## Charging environment

- Use the battery with the original factory charger to charge, do not use other brands or models of charger side charging.
- Please charge the battery at the ambient temperature of 10°C ~ 40°C to ensure that there are no flammable substances around and good ventilation.
- Charging time description: the charging time of the battery is no more than 12 hours. Overcharging will affect the battery life, and there are safety risks.
- At the early stage of charging, the electric quantity rises quickly, and then arrives slowly. This is the procedure set for charging safety, which is normal.
- In winter, when the outdoor temperature is low and the environment is lower than 0°C, the battery will stop charging. This is a normal phenomenon. Please place the battery at a suitable ambient temperature for charging to ensure the charging effect.
- Outdoor charging is strictly prohibited in bad weather.
- During the charging process, the charger has the effect of temperature rise and the surface temperature is higher, which is a normal phenomenon. Please be careful to use and avoid touching by children.

## Storage environment

- After the battery is placed in the car, it will slowly consume the battery power due to the working reason of the vehicle. The vehicle can be placed for up to two months. The meter shows that the decline of battery power is normal.
- Please store the battery at the ambient temperature of 0°C~25°C. Do not store the battery in an environment higher than 45°C, otherwise the battery will suffer irreversible capacity decay.
- Do not use the vehicle for a long time (such as winter, summer goods other special circumstances), must remove the battery stored separately, and regular maintenance charge, the longest tail charging time to use the charger to charge 2 hours every two months, otherwise will probably lead to the battery power completely exhausted, produce irreversible damage, for this kind of problem, the battery failure will not warranty scope.
- The most suitable storage capacity of the battery is 50%. Long-term storage of less than 10% or more than 90% will lead to irreversible capacity decay of the battery.
- Avoid storing batteries in hazardous locations. Falls may cause uncontrolled damage within the battery and may result in battery leaks, heat, cat smoke, fire or explosion

## Parts instruction

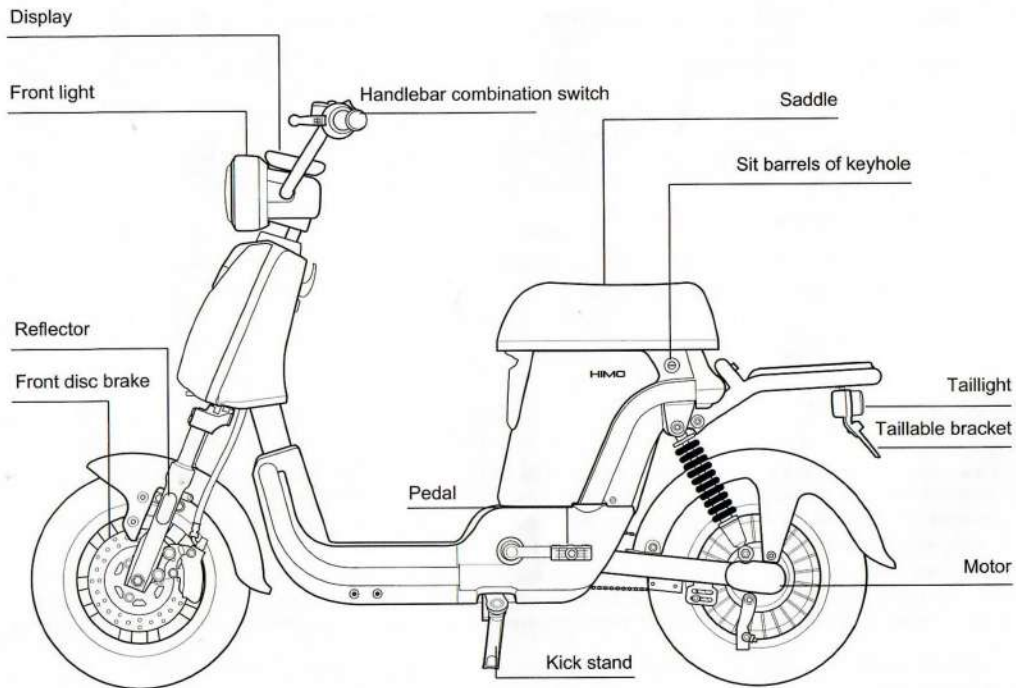

## Solutions of trouble

Problems	Reasons for the problem	Solution way
When the power is turned on , the bike can not be powered on	Bike is not powered	<ol style="list-style-type: none"> <li>1. Check whether the battery plug is properly inserted</li> <li>2. Battery undervoltage, charge the battery</li> </ol>
Turn on the power and turn on the handle	<ol style="list-style-type: none"> <li>1. is in the braking state and 2. is in the stopping state</li> <li>3. The side brace is not folded up.</li> <li>4. Start switch fault</li> </ol>	<ol style="list-style-type: none"> <li>1. Is the brake handle in the braking state</li> <li>2. Start the car according to the instructions</li> <li>3. Fold up the side brace and remove the P gear</li> <li>4. Plscontact theafter-service</li> </ol>
Insufficient mileage	<ol style="list-style-type: none"> <li>1. Battery undercharge</li> <li>2. Tire pressure deficiency</li> <li>3. Frequent brake start</li> <li>4. Battery aging or normal</li> <li>5. Low ambient temperature, Battery capacity attenuation</li> </ol>	<ol style="list-style-type: none"> <li>1. Check if the charger damage or not</li> <li>2. Check tire pressure before using</li> <li>3. Develop good driving habits</li> <li>4. Replace the battery</li> <li>5. Belong to normal phenomenon</li> </ol>
The battery fails to charge	<ol style="list-style-type: none"> <li>1. The charger is not plugged in properly</li> <li>2. Battery temperature is too low.</li> <li>3. Battery temperature is too high</li> </ol>	<ol style="list-style-type: none"> <li>1. Check if the plug is loose</li> <li>2. Wait for the battery to return to charging temperature</li> <li>3. Wait for the battery to return to charging temperature</li> </ol>
Instrument no display	<ol style="list-style-type: none"> <li>1. No power supply for bike</li> <li>2. Battery under voltage</li> <li>3. Instrument faults</li> </ol>	<ol style="list-style-type: none"> <li>1. Check that the battery is plugged properly</li> <li>2. Battery undervoltage, charge the battery</li> <li>3. Contact after-sales service to replace damaged parts</li> </ol>
USB cannot be charged	<ol style="list-style-type: none"> <li>1. The plug is not inserted properly</li> <li>2. The connection line does not meet the operating standard</li> <li>3. USB charger is damaged</li> </ol>	<ol style="list-style-type: none"> <li>1. check the plug for looseness</li> <li>2. The battery is undervoltage. Charge the battery.</li> <li>3. Contact afte-service, Replacement of damaged parts</li> </ol>

## Maintenance and repair

### Maintenance and cleaning instructions

- Do not flush with water to avoid potential accidents caused by wetting of internal electronic components and wiring;
- Please use a neutral cleaner, gently wipe paint or plastic parts with a cloth, and then wipe with a dry cloth can be;
- Please use lubricating oil to wipe the metal parts of the car body for maintenance;
- It is strictly forbidden to oil the brake parts to avoid causing brake failure and bringing danger.

### Regular vehicle inspection

- Whether the fasteners are locked, whether the joints are normal;
- Whether the tread of the outside tire is worn and cracked, whether the front and rear tire pressure is appropriate, whether the drive system is smooth;
- Whether the brake system is working properly

### Vehicle storage method

- When the product is not in use for a long time, please do not store it in the outdoor environment, strong light irradiation and the environment below zero for a long time. The distance from the heat source (heating equipment, etc.) should not be less than 2M;
- Store in a dry, clean, well-ventilated indoor environment with a temperature of 10°C~45°C and a relative humidity of less than 90%;
- If you do not use the car for a long time, pay attention to regular charging (generally about two months apart) to maintain battery performance;
- This product should not be in contact with corrosive liquid to avoid any mechanical impact and pressure.

## Transportation

- In the process of transportation, should not be subjected to violent mechanical impact, sun, rain, chemical corrosive substances and harmful gas erosion;
- In the process of loading and unloading, the product should be handled gently, strictly prevent throw, roll and weight

## After-sales service

In order to protect your interests and support your electric vehicle product service, according to the product quality law of the People's Republic of China, the protection law of the People's Republic of China on the rights and interests of users and relevant laws and the relevant provisions of the state on three guarantees of after-sales service, the specific provisions on HIMO electric after-sales service are as follows:

### 7 days no reason to return

- If the goods are rejected or intercepted due to non-quality reasons after shipment, the user shall bear the round trip freight.
- Within 7 days after receipt, because of quality problems, in the case of does not affect the goods in good condition (affect the situation of the goods in good condition including but not limited to: 3 packets of prooves and invoice lost, artificial damage, maintenance and protection label damage, product appearance, or the outer packing damage, 10 km mileage super, the accessory missing accessories, etc.) round-trip freight and MoSunFei shall be borne by the user. If the package is lost or damaged, the customer shall bear the original packaging cost (excluding the packaging cost incurred by logistics when the package is returned).
- Within 7 days after receipt, if the goods are returned or replaced due to quality problems, the return freight shall be borne by the merchant.
- Within 7 days after receipt, if the goods are returned or replaced due to quality problems, the return freight shall be borne by the merchant.

No return for cycling over 100km;

It can be replaced within 15 days due to quality problems;

More than 15 days, within the warranty period, can be repaired.

## The warranty policy

- HIMO official customer service center will provide you with free after-sales service during the warranty period. If the service period exceeds the scope of "three guarantees", according to when HIMO official customer service center will provide you with paid after-sales service based on local market conditions and maintenance prices.
- If the product you purchased cannot run due to quality problems, HIMO official customer service center will provide repair service for you.
- The warranty period of products sold online is calculated from the date of delivery receipt signed by the user

## Non-warranty policy

The following circumstances do not belong to the scope of warranty service, we will provide you with paid after-sales service.

- Three guarantees of validity have been issued, the invoice is missing or changed, damage caused by force majeure.
- Repair, misuse, collision, negligence, abuse, accident, modification, improper use of this product without HIMO approval, frame serial number damaged.
- The model of the "three guarantees" certificate is not in conformity with the model of the repair product or is changed, so as to make proper maintenance according to the operating instructions.
- Due to improper use, direct impact caused deformation, external force collision or car crash caused zero damage, puncture, glass, sharp small stone caused by puncture, air leakage, consumables loss did not replace in time, causing damage to other parts, seat surface hanging broken; Violence or man-made damage to the frame is not covered by the warranty.
- Vehicle frame, parts paint surface may be due to rain, collision, friction and other external environmental factors caused by corrosion, paint, or storage place is not good, after a long term use of paint surface off, metal painting or plastic parts and other natural fade.
- If the parts are damaged or the functions fail due to abnormal cycling movements, such as extreme crossing, performing special effects, descending stairs, jumping, etc.
- Due to the over-limit use caused by the deformation or cracking of the vehicle frame and other emotional tears, also does not belong to the warranty scope.

Note: Shanghai HIMO electric technology co., LTD has the final right to interpret the HIMO electric vehicle after-sales service policy.



## Scope of warranty exemption

Products sold under the following circumstances are not covered by the warranty service and require users to pay for maintenance and related services:

- Exceeding the specified service period and scope based on the HIMO electric vehicle parts three-package standard.
- The user fails to meet the HIMO electric vehicle product usage instructions, which result in the production failure or damage caused by the correct use, driving, maintenance and adjustment.
- Products sold due to rain, ice and snow immersion, smoke, drugs, chemical crystal corrosion caused by damage or natural breakdown or damage. Wastage is not covered by the warranty.
- Failure or damage caused by force majeure (including but not limited to earthquake, typhoon, fire, flood, social event, mass event, force crime, etc.).
- The user fails to use and maintain the battery normally, and keeps the battery for a long time (the battery is connected to the whole vehicle for one month, and the initial battery quantity is less than 50% and more than 2 months), which fails to charge in time, resulting in the battery feeding and low voltage that cannot be repaired.
- Modification, decomposition, maintenance and damage to the normal use of the whole product and parts.
- The user USES the HIMO electric vehicle parts damaged or changes the circuit and line configuration without authorization.
- Product failure or damage caused by human factors such as collision, falling, overload, overspeed, etc.
- There is no valid warranty certificate, after-sales service card or purchase product invoice, certificate or card number inconsistent with the product

# RoHS

Model name	HIMOTI E-Bicycle					
Name and content of harmful substances in products						
Parts name	Harmful substances					
	(Pb)	(Hg)	(Cd)	(Cr(VI))	(PBB)	(PBDE)
Display	○	×	○	○	○	○
Head light	○	×	○	○	○	○
Tail light	○	×	○	○	○	○
Battery	○	×	○	○	○	○
Controller	○	×	○	○	○	○
Charger	○	×	○	○	○	○

1. This form is prepared according to the provisions of SJ/T 1136
- : indicates that the content of the hazardous substance in all homogeneous materials of the part is below the limit specified in GB/T26572.
- ×: indicates that the content of the hazardous substance in at least one homogeneous material of the part exceeds the limit specified in GB/T26572.



HIMO official official account

# HIMO

The principal: Shanghai Himo electric technology co. LTD

Manufacturer: Tianjin Fuji-ta Technology Co. LTD

Production plant: Tianjin Fuji-ta Technology Co. LTD

Factory address: 400-182-9808, intersection of Taian road and Emma road, south district, Jinghai economic development zone, Tianjin