Owner's Manual

- 1 -

READ THIS MANUAL BEFORE OPERATING YOUR E-SCOOTER

STRONGLY SUGGESTS THE OPERATOR OF THIS PRODUCT BE 16 YEARS OF
AGE OR OLDER

- 2 -

For the most recent version of this user's manual and for all updated product information, please connect with local dealer.

YOUR INSURANCE POLICIES MAY NOT PROVIDE COVERAGE FOR ACCIDENTS INVOLVING USE OF THE E-SCOOTER. TO DETERMINE IF COVERAGE IS PROVIDED YOU SHOULD CONTACT YOUR INSURANCE COMPANY OR AGENT.

- 3 -

Introduction

Dear Customer,

Wow! You are excited! You have just received your brand new E-Scooter! We are excited too, because as designers and developers of our bikes, we want to make you happy, and we believe that your new e-scooter will give you lots of fun.

I know that you want to get this bike on the road immediately, but **please STOP!**

Why? Well, first of all, you need to charge your batteries fully before using it. So, while your e-bike is charging, take the time to read this manual. We have worked hard to make it as readable and fun as possible! This manual will help prevent injury and teach you how to care for your new e-bike.

► It is the Owner's responsibility to carefully read all of the contents of this manual and to comply with all laws pertaining to the operation of bicycles and/or electric bicycles in your

- 4 -

local jurisdiction. If you have any questions please consult with the Laws web page or consult your local department of motor vehicles for clarification.

▶ These electric motorbikes are not classified as motor vehicles, however, to drive them on the roads, various states have differing laws.

▶ We have worked hard to provide you a quality product, well designed, and without defects. That is our responsibility. You too have a part to play...with proper care and maintenance and attention to motorbike safety rules, our e-bike will give you years of enjoyment.

▶ Please read the instructions carefully before using. Do not ride this bicycle until you have read and thoroughly understand the Owner's manual. It contains information critical to your safety. If you have questions about the operation of this electric bicycle, consult your authorized dealer. It is extremely important that you follow the safety guidelines contained in this manual in order to ensure your maximum safety. If you loan your bike to anyone make sure they also know how to operate it safely.

▶ When using, the load should not be greater than the maximum capacity, and please pay attention to increase the braking distance during rainy or snowy days.

▶ This E-Motorbike is not afraid of the rain and snow, but it can't be submerged in water. It

will cause short circuit and damage to the electric apparatus, when water submerges the rear wheel electronic hub.

- ▶ The exposed metal contact on the battery box is positive and electronegative electrode, can't be touched at the same time with wet hands, also it can't be kept in touch with anything metal at the same time, otherwise it will cause short circuit and accidents!
- ▶ Please don't dismantle and repair the spare parts by yourself, please go to the local distributor or the servicing station to repair if necessary.

► Please take time to record the following information:

Recording Your Serial Number

VIN: _____

Model: _____

Color: _____

Date of Purchasing : _____

Distributor: _____

UNDERSTANDING THIS MANUAL

This Manual contain many **▲ WARNING** notes concerning the consequences of failure to maintain or inspect your E-SCOOTER. A **▲ WARNING** means that failure to follow the instructions following it may result in injury to the rider or others during use, which may include loosing control and falling. Because any fall can result in serious injury or even death, we do not repeat the warning of possible injury or death whenever the risk of falling is mentioned. A **▲ CAUTION** on the other hand means that failure to follow the instructions may result in damage to the E-SCOOTER or component during installation or use. (i.e. risk or property (product) damage only).

Thank you for the purchasing the electrical powered Motorcycle, The Motorcycle complies with the European Motor Vehicle Safety Regulation Act 2002/24/EC).

GENERAL SAFETY GUIDELINES & RESTRICTIONS

7. Don't weave through traffic or make any moves that may surprise people with whom you are sharing the road.

8. Never carry anything which obstructs your vision or your complete control of the E-SCOOTER or which could become entangled in the moving parts of the E-SCOOTER.

9. Never hitch a ride by holding on to another vehicle.

NEITHER YADEA Ltd. NOR THE RETAIL SELLER OF THE E-SCOOTER IS RESPONSIBLE FOR THE CONSEQUENCES OF FAILURE TO COMPLY WITH FEDERAL AND PROVINCIAL ORDINANCES RELATING TO THE USE OF THE E-SCOOTER.

! WARNING

ALWAYS USE A HELMET WHILE RIDING THE E-SCOOTER.

EU safety regulations require that you use a helmet like those used by human powered bike riders while riding the E-SCOOTER.

E-SCOOTER should not be used under any circumstances without properly wearing a helmet.

! WARNING

IN ADDITION TO THE REQUIREMENTS ABOVE, THE E-SCOOTER IS NOT TO BE RIDDEN / USED:

-
1. on any roadways where the speed limit is in excess of 45 km/h
 2. on any sidewalks or pedestrian walkways.
 3. on any bumpy, rough or unpaved surfaces.
 4. in darkness without lights on
 5. on sandy or gravel covered surfaces.
 6. by any person weighing more than 150 kgs.
 7. by any person with an inseam of less than 22".

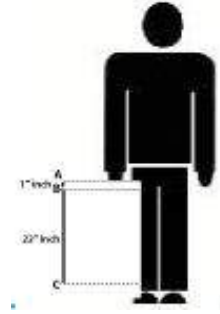

GENERAL SAFETY GUIDELINES & RESTRICTIONS

8. by any physically or mentally challenged person.
9. by any person with vision, balance, hearing or coordination impairments.
10. by any person using headphones or a cellular phone [They mask traffic sounds and emergency vehicle sirens, distract you from concentrating on what's going on around you, and their wires can tangle in the moving parts of the E-SCOOTER , causing you to lose control].

- 10 -

-
11. to carry more than 4 kgs of cargo in the cargo compartment (in addition to the rider).
 12. in excess of 45 kmph (with or without the motor activated).
 13. by barefoot riders or those wearing sandals, open toed, high heeled, platform or slip on footwear
 14. by any person who has ingested any alcohol or drug that could impair their ability to operate the E-SCOOTER.
 15. without 2 hands on the handle bar.
 16. while not seated on the seat.
 17. to jump ramps, curbs, or objects or attempt any stunts.
 18. with excessive speed for the terrain, circumstances or maneuver with clothing or extremities in close proximity to the drive chain or any moving parts.
 19. beyond your ability or prior experience.
 20. by stopping with only the front brake. Use both brakes simultaneously.
 21. Do not try to accelerate and have the brake (s) on at the same time.
- [This may cause damage to the motor or drive train or cause the motor or drive train to overheat.]

BEFORE EACH RIDE:**! CAUTION**

1. Make sure you properly wear a helmet.
2. Wear protective clothing and gloves.
3. Wear eye protection that does not interfere with your peripheral vision.
4. Check local and state laws before operating the E-SCOOTER in any area.
5. Make sure all tail/brake lights, turn signals and headlight are operational.
6. Make sure the horn is operational.
7. Make sure the brakes are properly adjusted and working correctly (see further detailed instructions).
8. Make sure you understand how the brakes work and that your hands can reach and squeeze the levers comfortably and hard enough to stop the E-SCOOTER safely.
9. Make sure the chain is properly adjusted (see further detailed instructions).
10. Make sure all parts of the E-SCOOTER are properly and securely fastened and adjusted, including but not limited to crank arms, wheels, all controls and cargo (Please refer to Assembly Instructions).

GENERAL SAFETY GUIDELINES & RESTRICTIONS

11. Make sure the tires are not excessively worn, do not have tears or cuts, and are properly seated on the rim and inflated to the proper pressure on the sidewall (DO NOT USE GAS STATION PUMPS FOR INFLATION).

12. Make sure the wheels spin straight and that the rims are not bent or damaged (front wheel must be undamaged for front brake to work properly).

13. Make sure the throttle is in the "OFF" position before turning E-SCOOTER key on.

This will prevent the E-SCOOTER from moving forward without notice once the ignition key is turned.

14. Make sure the "Air Switch" under the seat is in the 'On' position before turning key on.



AFTER EACH RIDE:

!WARNING

1. Make sure that the ignition key is turned OFF and that all keys are removed and kept in a safe place.
2. Make sure to plug the battery on charge.
3. Make sure the throttle is rotated to the off position
4. Ensure that the kickstand is used so the E-SCOOTER will not fall over and get damaged.
5. Ensure the E-SCOOTER is not kept outdoors or where moisture can damage it.
6. Do not charge or store the E-SCOOTER closer than 20 feet from any flame (e.g. furnace, fireplace, water heater, space heater).
7. Do not allow children under 16 to play on or near the unattended E-SCOOTER.

!WARNING FAILURE TO FOLLOW THESE OPERATION INSTRUCTIONS CAN RESULT IN SERIOUS INJURY OR DEATH OR COULD RESULT IN AN ELECTRICAL SHORT AND OR FIRE.

!WARNING DO NOT MAKE ANY ALTERATIONS OR MODIFICATIONS TO THE MOTORINOTM ,

OR ADD ANY PARTS NOT AUTHORIZED BY YADEA Ltd. EXCEPT THOSE DISCUSSED IN THIS MANUAL OR THOSE REQUIRED BY LAW. DO NOT REMOVE ANY REFLECTORS, LIGHTS OR OTHER STANDARD EQUIPMENT. DOING THAT WILL AVOID YOUR WARRANTY.

All authorized replacement parts are listed on the parts list enclosed or by calling your local dealer.

ASSEMBLY INSTRUCTIONS

Your E-SCOOTER may come in three different ways:

- a) 95% assembled -you only need to install the mirrors and the cargo box
- b) 90% assembled -you need to install (a) plus front wheel
- c) 85% assembled -you need to install (b) plus handle bar and some plastic elements.

All instructions for (a), (b) and (c) are described below with supporting pictures.

HANDLE BAR

Insert the top part of the handlebar into the handlebar post as shown on the picture. Locate the attachment bolt with the nut and the spacer and insert the bolt in the hole from back to front. Slide the spacer into the bolt with the round side facing the handlebar post. Screw the nut on top and tighten it. After attached, the handlebar should look as on the picture below.

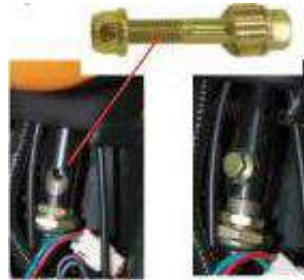

FRONT PANELE-SCOOTER

Locate the front panel and connect the head light wire plug to the correspondent plug at the front of the bike as shown on the picture. Insert the plastic fins of the front panel at the corresponding channels of the base (see the picture) and slide it upwards until the holes of the back black cover match the screw holes of the cover. Insert the screws into the holes of the black back cover and screw them onto the front cover.



- 16 -

E-SCOOTER

Locate the front panel and connect the head light wire plug to the correspondent plug at the front of the bike as shown on the picture. Locate the front hole in the middle of the panel and use the included short bolt to attach it to the body. Locate all attachment points of the cover, insert the screws into the holes of the black cover and screw them onto the front cover.



ASSEMBLY INSTRUCTIONS

a. FRONT WHEEL WITH DRUM BRAKE

The front end of the bike is attached to the crate with a bolt which is the original axle. Unscrew the nut carefully and remove the axle. Locate the front wheel and insert the break mechanism into it.



- 17 -

Insert the axle first in the swingarm of the front fork and then in the break drum and the wheel. Make sure to apply the spacer before inserting the axle in the other side of the fork. Tighten the nuts firmly.



b. FRONT WHEEL WITH DISK BREAK

Before installing the front wheel gently take apart disk break pads using a wide flat screwdriver, so the wheel disk can squeeze between the pads. Push the speedometer black cap against the wheel and position it in the way that the axle bolt can go through it. Tighten firmly the nut at the opposite side.



STORAGE BOX

Locate the storage box and the hardware necessary to mount it on the back of the Scooter. Mount the bike rack using the bolts and the nuts in the package. Install the box on the top of the rack using the metal bracket and bolts.



ASSEMBLY INSTRUCTIONS

REARVIEW MIRRORS

Locate the mirrors included with your E-SCOOTER .Connect the three wires of the mirrors to the same color wires coming out of the mirror holes. Use a hexagonal ("Allen" or "Hex" wrench) to attach the mirrors as shown in the pictures. Make sure you use the included spacer under the mirror base if necessary. Then screw the bolt onto the threaded ends as shown on picture below.

When you are sitting on the scooter you can adjust the mirrors by pushing the mirror surface up, down, left and right.

(Different Operating for assembly the Mirrors for different scooter.)

The mirror needs to be tightened fully for assembly to be safe. Repeat the process for the other mirrors. Once mirrors are installed, they should look like the picture below. Make sure to adjust the mirrors before use, so that you can see behind you as you ride.



BATTERY

BEFORE OPERATING YOUR NEW FOR THE FIRST TIME, CHARGE THE BATTERY MOTORINOTM FOR 8-12 HOURS, BUT UNDER NO CIRCUMSTANCES IN EXCESS OF 18 HOURS. Be sure to charge the E-SCOOTER after each use. Keeping the battery properly charged will help extend the battery life. Do not use the E-SCOOTER while the power indicator on the instrument panel shows low energy. If the E-SCOOTER is over-used the battery's life will be reduced. The E-SCOOTER uses a 48V-60V (volt) battery pack. To charge the battery, connect the 3-pin plug into the charging receptacle located directly below the front seat. The battery must be charged while installed in the E-SCOOTER. If you notice anything unusual about the battery such as a cracked or leaking battery case, a battery that gets hot while being used or charged, a battery case that appears "puffy" or "bloated" etc, or there are any other problems with the battery, please contact your local dealer. The battery is sealed and is



NOT user serviceable. Do not attempt to repair, remove, adjust or in any way alter any internal or electrical components, controls or wiring without first speaking with a customer service representative.

The main battery weights approximately fifty six (56) kgs. There are total ten(10) cells(12V20Ah/cell) connecting with wires. There is no need to remove it from the E-SCOOTER unless you are replacing it. Use caution on removal. To replace the main battery pack, lift the foot mat and unlock the lock located on the left side of the E-SCOOTER (using the ignition key). Proceed to pull the batter out utilizing the handle. Disconnect the battery cable. The E-SCOOTER is equipped with a 48V battery charger that will interrupt the charging process once the battery has received a sufficient charge. Hereby strongly suggests that the charger not be used in excess of 18 hours to prevent any unnecessary wear on the battery or charger itself. Charging for periods greater than 18hours may reduce the overall life expectancy and Efficiency of these items.

! CAUTION DO NOT DROP THE BATTERY.

! CAUTION TO AVOID DAMAGE TO THE BATTERY WHEN CHARGING, USE ONLY THE CHARGER PROVIDED WITH DEALER.

1. **!WARNING** DO NOT CHARGE OR STORE THE MOTORINOTM CLOSER THAN 20 FEET FROM ANY FLAME (E.G. FURNACE, FIREPLACE, WATER HEATER, SPACE HEATER)
2. Be sure to only use 110-230V AC with the E-SCOOTER charger. Also make sure the plug is inserted into a three prong grounded AC outlet.
3. PLUG the POWER INPUT CORD into the E-SCOOTER charging receptacle located below the front of the seat. See picture above.
4. Plug the MOTORINOTM 48-72V battery charger into a 110-230V AC power source.
5. The CHARGER INDICATOR LIGHT will illuminate confirming that power is connected to the charger. If the light does not come on check all connections. If it still does not come on after checking all connections, fuses and that your AC plug is working, unplug the charger and call your local MOTORINOTM dealer.

BATTERY

6. **!WARNING** DO NOT KEEP THE CONNECTED TO THE CHARGER FOR LONGER THAN 18 HOURS UNDER ANY CIRCUMSTANCES! DOING SO COULD CAUSE THE BATTERY OR CHARGER TO OVERHEAT AND CAUSE A FIRE.

7. When the light on the 48V charger is “red”, the E-SCOOTER battery is being properly charged. When the E-SCOOTER battery is fully charged, the light will turn “green”. If this does not occur after 16 hours of charging, unplug the charger and call your local dealer. Normal recharge time for the main battery is 6-8 hours (assuming it is not 100% discharged).

8. Disconnect the charger from the 220V Power Source in American area.

9. Disconnect the Input Cord from the Charging Receptacle in American area.

10. **!WARNING** NEVER LEAVE THE BATTERY CHARGER CONNECTED TO THE 220V POWER SOURCE OR THE E-SCOOTER WHEN NOT CHARGING THE BATTERY IN AMERICAN AREA. KEEPING THE CHARGER PLUGGED INTO THE 110V/220V POWER SOURCE AND NOT THE BATTERY COULD CAUSE THE CHARGER TO OVERHEAT AND OR CAUSE A FIRE.

11. When storing your E-SCOOTER for lengthy periods of time, the battery should be charged at

least once a month to avoid full depletion.

!WARNING

FAILURE TO KEEP THE E-SCOOTER BATTERY CHARGED WILL CAUSE TOTAL BATTERY FAILURE. DO NOT ALLOW BATTERY TO BECOME FULLY DISCHARGED!!! ALWAYS RECHARGE THE BATTERY BEFORE THE POWER INDICATOR ON THE INSTRUMENT PANEL SHOWS NO POWER. ALLOWING THE BATTERY TO FULLY DISCHARGE WILL REDUCE BATTERY LIFE AND MAY RUIN THE BATTERY OR COULD CAUSE THE BATTERY OR CHARGER TO OVERHEAT AND CAUSE A FIRE THE NEXT TIME THE E-SCOOTER IS CHARGED.

!WARNING

BATTERY POSTS, TERMINALS, POWER CORDS AND BRAKE CABLES MAY CONTAIN LEAD AND LEAD COMPOUNDS, AND OTHER CHEMICALS. WASH HANDS AFTER HANDLING.

BATTERY

BATTERY RECYCLING

When maintained and used properly, (by following charging and storage guidelines), the Lead Acid Battery Pack used in this product has a normal lifespan of two to three years. When the battery pack no longer holds a charge or is unable to be charged properly, it should be removed from the E-SCOOTER and delivered to a recycling facility. Federal Laws prohibit disposal of lead-acid batteries in everyday trash. Please contact your local solid waste or recycling authority for recycling information in your area.

GENERAL USAGE NOTES

Break-in Period: Your E-SCOOTER will last longer and work better when it is broken in properly. Brake control cables, chains and axle nuts may get loose when a new E-SCOOTER is first used and may require an adjustment. We suggest that the brakes and axle nuts be checked every 30 days and adjusted if necessary.

The E-SCOOTER scooter can be use without pedals but pedaling the E-SCOOTER upon starting will save battery life and will make it easier to balance. The E-SCOOTER can also be pedaled in situation where the battery power is too low due to a failure to charge or exceeding its distance range. The rider can also rest his or her feet on the pedals while riding the E-SCOOTER. Turning the throttle all the way up and riding the scooter all the time on a full throttle will also reduce the range and the battery life. We suggest you to start smoothly and turn the throttle 1/4 turn down when you have built a momentum.

It is a good idea to keep a tool kit with you when you ride. You should also carry 2 spare inner tubes that fit the wheel and tire size as well as a manual air pump (with gauge) to re-inflate the tire if you have a flat or it becomes low during use.

If your E-SCOOTER sustains an impact:

!WARNING A CRASH OR OTHER IMPACT CAN PUT EXTRAORDINARY STRESS ON COMPONENTS, CAUSING THEM TO FATIGUE PREMATURELY. COMPONENTS SUFFERING FROM STRESS FATIGUE CAN FAIL SUDDENLY AND CATASTROPHICALLY, CAUSING LOSS OF CONTROL, SERIOUS INJURY OR DEATH.

First, check yourself for injuries, and take care of them as best you can.

- 27 -

Seek medical help if necessary. Next, if your E-SCOOTER is damaged, perform the checks described in this manual. If you are unable to fix any or all damage/problems, or if you find any bent, scored, or discolored parts, please call your local SCOOTER dealer.

!WARNING IF YOU HAVE ANY DOUBT ABOUT THE CONDITION OF THE SCOOTER OR ANY OF ITS PARTS, DONT USE IT . CALL YOUR DEALER.

MAINTENANCE

Technological breakthroughs have made components more complex than ever before, and the pace of innovation is increasing. This on-going revolution makes it impossible for this manual to provide all the information required to properly repair and/or maintain your E-SCOOTER. In order to help minimize the chances of an accident and possible injury, it is critical that you have all repair and maintenance work performed regularly.

For more detailed maintenance instructions or for ordering replacement parts please contact your E-SCOOTER dealer. Local bicycle retail stores, which have service facilities in your area, can also assist you with certain non-electrical repairs or adjustments that you are not qualified to make or for which you do not have the specific or specialized tools needed for repair.

The fact that these scooters have no combustion engine, no transmission, no belts, no chains, no clutch, no ignition plugs, no carburetor, and uses no gasoline and no lubricants means it requires basically no maintenance. The unique design of the direct drive system and the use of regenerative brushless motor braking system confine all friction in E-SCOOTER scooters only in the two bearings of the front axle and the two bearings in the motor and make it much easier to maintain than other electric scooters.

In generally all the regular mechanic maintenance is to:

- Adjust the brakes
- Check the nuts and bolts
- Check tire pressure
- Check the chain

BRAKES MAINTENANCE

Front and rear break cables may get stretched. Tighten the nuts at the threaded end of the cable to adjust them. If the breaking power decrease, check the break pads. If necessary clean them with sand paper. If the break pads are worn out, replace them. If the break cable is stretched to the point that there is no more threads left at the end, unscrew the lever and turned it away from the cable.

- 29 -

Check both axle nuts regularly and especially the rear one. Make sure to tighten the nuts firmly when you change a tube.



Rear Axle nuts -Check them regularly



MAINTENANCE

FLAT TIRE REPAIR

Your E-SCOOTER may come with tubeless tires or tires with tubes. For tubeless tires we recommend to carry with you a tubeless tire repair kit and use it if the magnitude of puncture permits. Then consults with professional tire repair service shop if this is sufficient.

!WARNING Don't ride or push your E-SCOOTER with flat tire. This will cause the tire beads to detach from the rim and possibly bent the rim.

If your E-SCOOTER comes with tube tires, follow the next instructions:

1. Depress the tire valve to let all the air out of the tube, which will assist in removing the wheel from the Scooter.
2. Remove the wheel from the E-SCOOTER using a wrench. Loosen the nuts counterclockwise and make sure to remove the wheel retention clips on the front wheel. Be sure to remember where all the spacers and washers belong. For rear tire removal you will also need to slip the chain off the rear sprocket to remove the wheel. The chain must be properly reinstalled and retention when reinstalling the rear wheel.

3. Remove one bead of the tire from the rim by grasping it at a point opposite the valve stem with both hands and, at the same time, lifting and peeling one side of the tire off the rim. If the bead is on too tight for you to unseat it with your hands use tire levers to lift the bead carefully over the tire rim. Tire levers can be purchased at any local bike shop. Push the valve stem through the wheel rim. Remove the inner tube.

4. Carefully check the outside and inside of the tire for the cause of the puncture and remove any debris or damaging material from the inside or outside of the tire.

! WARNING IF THE TIRE IS CUT, YOU MUST REPLACE THE TIRE TO PREVENT ANY SUDDEN AND CATASTROPHIC FAILURE CAUSING LOSS OF CONTROL, SERIOUS INJURY OR DEATH. Replacement parts are able to be purchased by calling your local SCOOTER dealer

! WARNING PATCHING A TUBE IS AN EMERGENCY REPAIR. CARELESS PATCHING OR APPLYING SEVERAL PATCHES CAN SERIOUSLY WEAKEN THE TUBE, RESULTING IN POSSIBLE TUBE FAILURE, WHICH COULD CAUSE YOU TO LOOSE CONTROL AND FALL. REPLACE A PATCHED TUBE AS SOON AS POSSIBLE.

5. Reinstall the tire and tube. Slip one tire bead over the rim. Inset the tube valve through its hold in the rim. Feed the tube carefully into the cavity of the tire. Inflate the tube just enough to give it some

shape. Starting at the valve stem and working around both sides of the rim to the side opposite the valve stem, use your thumbs to push and seat the other bead of the tire inside the rim. Be careful not to pinch the tube between the tire bead and the wheel rim. If you have trouble getting the last few inches of bead over the edge of the rim with thumb pressure, use a tire lever and be careful not to pinch the tube.

! CAUTION IF YOU USE A SCREWDRIVER OR ANY TOOL OTHER THAN A TIRE LEVER, YOU ARE LIKELY TO PUNCTURE THE TUBE.

6. Check to make sure that the tire is evenly seated around both sides of the rim and that the tube is inside the tire beads. Push the valve stem into the tire to make sure that its base is seated within the tire's beads. Inflate the tube slowly to the recommended pressure on the tire sidewall, all the while checking to make sure that the tire beads stay seated in the rim.

OPERATING INSTRUCTIONS



KEY AND THROTTLE OPERATION

ON/OFF/LOCK Switch: (ignition)

1. E-SCOOTER is ON. Turn it ON only when you are ready to go. Turn it OFF when you are not riding and remove key.
2. E-SCOOTER is OFF. Turn it OFF when not in use to preserve the battery.
3. Push the key in on this position to lock the handlebar and turn it to position.
4. Handlebar is locked. The key can be removed.

! CAUTION

BEFORE OPERATING YOUR E-SCOOTER, MAKE SURE THAT THE THROTTLE GRIP IS NOT ROTATED TO THE "ON" POSITION!!! MAKE ALSO SURE THAT YOUR THROTTLE IS NOT "STICKY" AND ROTATES FREELY BACK TO THE INITIAL POSITION SEE PICTURE FOR CORRECT PLACEMENT OF LEVER BEFORE USAGE!!!

- 34 -

THROTTLE CONTROL

The E-SCOOTER uses a speed changing throttle grip. It is on the right side of the handlebar. Rotate the throttle grip toward the seat to accelerate and rotate forward away from the seat to slow down.



E-SCOOTER
control switches
and throttle



E-SCOOTER control switches
and throttle



It is suggested after acceleration to turn back 1/4 turn the throttle. This will increase your range and increase your battery life.

OPERATING INSTRUCTIONS

1. Turn the key to the 'ON' position, then turn the Throttle gradually to accelerate.
2. To prevent losing control of the vehicle, please turn the Throttle slowly until the speed increases.
3. Do not turn the Throttle until you are in the position to drive.
4. To stop, release the throttle and apply the front and rear brake simultaneously. You can decelerate by slightly pressing the brakes to start regeneration mode.
5. To move, release the brakes and turn the Throttle gradually.
6. When you turn move the turn signal switch left or right and don't forget to press it to turn it off.
7. The Brushless motor makes a small electromagnetic noise when turning the Throttle to start. This is normal.
8. Please, for your safety and security, take the key out when you are not riding.



TORQUE/GEAR SWITCH

The torque/gear switch is located beside the throttle. If you are driving on a flat or low hill road, you will achieve a Torque/Gear switch maximum range when you ride on low torque (economy mode) When you ride on moderate hills, you will achieve a maximum speed for the hill if you switch to high torque. When you ride on steep hill you should switch to high Torque for maximum performance.



! CAUTION

BEFORE OPERATING YOUR MOTORINO TM MAKE SURE THAT THE THROTTLE GRIP IS NOT ROTATED TO THE "ON" POSITION!!! MAKE ALSO SURE THAT YOUR THROTTLE IS NOT "STICKY" AND ROTATES FREELY BACK TO THE INITIAL POSITION.

The distance and speed depend upon various elements of the rider's style and the road conditions. A constant speed and less stops will ensure longer range. Other factors include weather, vehicle

condition, and battery charge. Drivers must be cautious when driving on rough roads, in poor weather, or when the battery charge is low. Always check the battery gauge while you are riding and be sure that it does not get too low too often.

OPERATING INSTRUCTIONS

The E-SCOOTER

scooters driving system consist of four main components:

- Battery
- Controller
- Throttle
- Motor

When the throttle is twisted, a signal goes to the controller, relevant to the angle of turning. Then the controller draws from the battery current, relevant to the required speed, controlled by the throttle and the power necessary to start the scooter or drive it uphill.



The higher the driving speed is and the steeper the hill is, the lower the range of the E-SCOOTER is. A second battery can be connected to the extra battery cable to extend the range.

The main breaker under the seat works as a high current protector. 48V DC to 12V DC inverters inverts the voltage to 12V. All light bulbs work on 12V.

The alarm works on 48V. It is vibration sensitive.

No matter that it consumes very little amount of power, it is recommended when the E-SCOOTER is stored for a long period of time the main breaker to be turned OFF.



Troubleshooting

Problem	Condition	Check	Solution
When I turn my Vehicle on nothing happens.	1. No any light Indications on the display.	1. Check the main Breaker under the seat if it is on "ON" position. 2. Check power Connection and battery level.	1. Flip the breaker lever on "ON" 2. Fasten connections.
	2.Power indication light is on	3.Check battery and motor connection	3.Clean battery terminal connectors. 4. Fasten the motor connections With the controller under seat

	3. Power indication light is on and the break light is "on".	4. Check the break Levers if they return to normal position.	5. Loosen the break. If there is any corrosion replace. Contact the supplier.
		5. Battery voltage is below 72 volts.	6. Charge or replace battery. Contact the supplier.
The Throttle does not work or switch on, the vehicle moves without acceleration.	1. The Throttle does not return to stop position.	1. Check the grip for damage 2. Check the Throttle spring. 3. The Throttle handle if it is loose	1. Use a flat head screwdriver to adjust the gap between the rubber handle and the cover. 2. Readjust the Throttle spring position. Contact the supplier 3. Check Throttle

			Connections. Contact the supplier.
The range is low	Charger light is off	1.Bad connection between the charger and the battery. 2.Charger doesn't charge	1. Check the charger plug position. 2. Replace the charger
	Battery doesn't hold the charge	1. Connections between the batteries are not good. 2. Bad battery cell	1.Checkallconnections between the batteries 2. Replace the bad battery cell.
The breaks are not working properly	1. Break levers go too deep 2. No breaking power	1.Needs adjustment 2. Break pads are dirty or need replacement.	1. Adjust the break cable – see instructions. 2. Clean break pads using sand paper or replace.

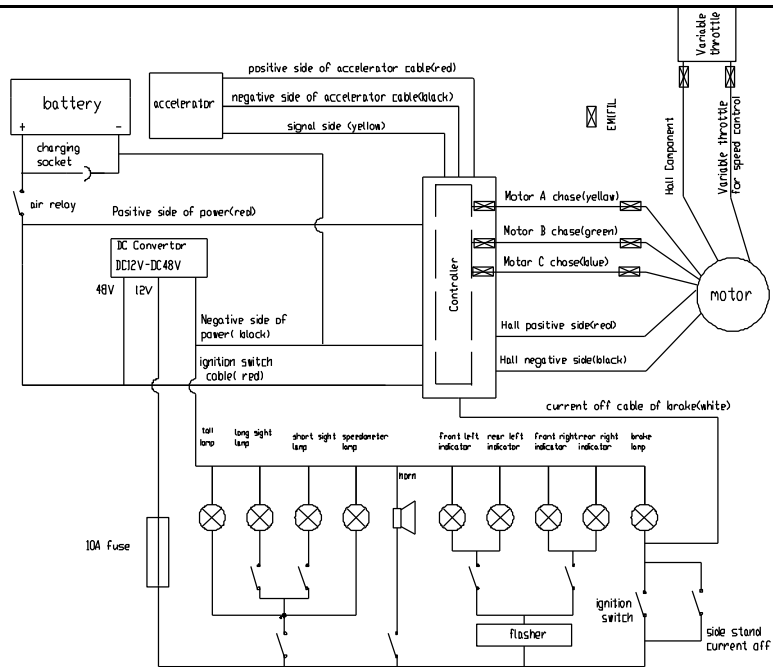



Li-ion Battery Charger Instructions

Manufacturer: Wu Xi Sans Electronic Co., Ltd.

Model:SSL300V48

1. Attention

- (1) There is high voltage inside the charger. Do not attempt to open it.
- (2) The charger is designed for indoor use only.
- (3) Do not attempt to recharge any non-rechargeable batteries.
- (4) Contact the manufacturers or retail dealers if there are any problems.
- (5) This appliance is not intended for use by persons (including children) with reduced physical, sensory or mental capabilities, or lack of experience and knowledge, unless they have been given supervision or instruction concerning use of the appliance by a person responsible for their safety.
- (6) This appliance can be used by children aged from 8 years and above and persons with reduced physical, sensory or mental capabilities or lack of experience and knowledge if they have been given supervision or instruction concerning use of the appliance in a safe way and understand the hazards involved. Children shall not play with the appliance. Cleaning and user maintenance shall not be made by children without supervision. Children should be supervised to ensure that they do not play with the appliance.
- (7) Important safety instructions – see these instructions
- (8) danger—to reduce the risk of fire or electric shock. Carefully follow these instructions
- (9) If the shape of the plug does not fit the power outlet, use an attachment plug adaptor of the proper configuration for the power outlet.
- (10) If the supply cord is damaged, it must be replaced by the manufacturer, its service agent or similarly qualified persons in order to avoid a hazard.

2. Characteristics

This manufacture is an intelligent charger, which employs the technology of power switching and is designed specifically for Li-ion battery charger. It's advantages are as follows:

- (1) Scope of input voltage:100-240V_{ac}. Operating and storage temperature Range: 0~30℃.
- (2) Low noise.
- (3) Prevent inverse connection automatically. The inverse connection electricity power is 0, which prevents the battery from damage caused by inverse connection electricity power.
- (4) Short circuit of electric is zero, permits a long time of short circuit.
- (5) Adopt entire hermetic sealing structure, could be used safely.
- (6) Meet all the requirements set by the European Union RoHS instructions.

3. Applicability

The manufacture is designed to charge 48V Li-ion battery pack.

4. Usage

- (1) Connect the connector pin of battery case firstly, and then the alternating current power supply.
- (2) When in charge process, the charging indicator light shows red; after fully charged, the charging indicator light shows green.
- (3) When the batteries are fully charged, (When the Green light is on), unplugging the connector pin of alternating current power supply firstly, and then that of battery case.

5. Trouble removal

- (1) The power indicator light does not illuminate.

A. Check whether there is alternating current power supply.

B. Check whether the connection is bad at the input interface.

When you eliminate the conditions above, please ask for help from the manufacture rs; do not attempt to repair it by yourself.

- (2) The charging indicator light is not work

check whether the output connector is well connected.



- check whether the battery can be used.
When you eliminate the conditions above, please ask for help from the manufacturers; do not attempt to repair it by yourself.
- (3) The charging indicator light is always red.
See whether the battery is damaged.
When you eliminate the conditions above, please ask for help from the manufacturers; do not attempt to repair it by yourself.

Do not dispose of electrical appliances as unsorted municipal waste, use separate collection facilities. Contact your local government for information regarding the collection systems available. If electrical appliances are disposed of in landfills or dumps, hazardous substances can leak into the groundwater and get into the food chain, damaging your health and well-being.

