

# WORKSHOP MANUAL



**GLYSTAR**

## CONTENTS

<b>CHARACTERISTICS</b> .....	<b>3</b>
<b>PRESENTATION OF THE 4 STROKE INJECTION SYSTEM (EFI)</b> .....	<b>4</b>
Synoptics .....	4
<b>DIAGNOSTIC TOOL</b> .....	<b>5</b>
Presentation .....	5
Connection of the diagnostic tool.....	6
<b>SPECIAL IMPORTANT POINTS</b> .....	<b>7</b>
Fuel system.....	7
<b>TIGHTENING TORQUES</b> .....	<b>8</b>
50 cc Engine .....	8
125-150 cc Engine.....	8
<b>SPECIAL TOOLS</b> .....	<b>9</b>
<b>INSTRUMENT PANEL</b> .....	<b>10</b>
Warning lights description and meanings .....	10
Changing the speedo units.....	11
Service function.....	11
<b>TRANSPONDER IMMOBILISER</b> .....	<b>12</b>
System programming .....	12
Reminder of the key memory procedure.....	12
Key memory check.....	12
Diagnostic LED readings .....	12
Additional information.....	13
Troubleshooting chart.....	14
Ignition principle schematic .....	15
<b>SPECIAL FEATURES OF THE 2<sup>nd</sup> GENERATION SYNCHRO BRAKING CONCEPT</b> .....	<b>16</b>
<b>WORKING ON 4-STROKE INJECTION SYSTEMS</b> .....	<b>17</b>
To remove the fuel pump .....	17
To remove the air injector .....	20
To remove the throttle housing and idle valve.....	21
<b>WORKING ON THE ABS/PBS SYSTEM</b> .....	<b>22</b>
ABS/PBS diagnostic.....	22
Troubleshooting chart.....	22
Incidents which cannot be detected by the ECU .....	25
ABS/PBS principle diagram.....	27
Parameter reading.....	28
To remove the control unit .....	29
To refit the control unit .....	32
<b>ABS/PBS SYSTEM BLEED METHOD</b> .....	<b>33</b>
Bleeding the front and rear circuits after changing the control unit.....	33
Bleeding the circuit after removing a front or rear caliper, a front or rear lower hydraulic hose .....	37
Bleeding the circuit after removing the front master cylinder or the upper front hydraulic hose (right side) .....	39
Bleeding the circuit after removing the rear master cylinder or the upper front hydraulic hose (left side integral braking) .....	41
Bleeding the power braking circuit .....	43
<b>HAZARD WARNING LIGHTS</b> .....	<b>45</b>
Functioning principle diagram .....	45
Operation .....	46
<b>LOCATION OF COMPONENTS</b> .....	<b>47</b>
Elystar 50 cc .....	47
Elystar 125-150 cc.....	48

## CHARACTERISTICS

### CHARACTERISTICS

	<b>FC5 Engine 50 cc</b>	<b>FD3 Engine 125 cc</b>	<b>FD4 Engine 150 cc</b>
Type	Air-cooled, single-cylinder 2-stroke injection	Single-cylinder 4-stroke coolant cooled	
Bore x stroke	40.3 x 39.1	57 x 48.9	57 x 58.9
Cubic capacity	49.1 cc	124.8 cc	150.3 cc
Max. power output	3.4 kW at 6900 rpm	9 kW at 8700 rpm	10.5 kW at 8200 rpm
Maximum torque	4.7 Nm at 6800 rpm	10.5 Nm at 7500 rpm	12.5 Nm at 6500 rpm
Gross compression ratio	11,4		
Timing		Chain driven overhead camshaft, 2-valve	
Engine oil capacity		1.25 L.	
Relay box capacity		0.12 L.	
Injection system	TSDI Two Stroke Direct Injection	EFI Electronic Fuel Injection	
Ignition / Carburettor	Synerject ECU	Synerject ECU	Synerject ECU
Petrol injector	Siemens green 37.028	Siemens black 8884	
Air injector	Synerject blue 37.073		
Fuel pressure regulator	Synerject	Synerject	
Petrol pump	Synerject	Synerject	
Throttle unit	Bing 235 011	Bing 7229 104	
Temperature sensor	Synerject	Synerject	
Lubrication		Trochoidal pump with relief valve	
Lubrication	Oil pump Mikuni ESOP-03		
Spark plug	NGK CPR8E	NGK CR7E	
Magneto flywheel	Mitsuba 180W	Mitsuba 235 W	
Starter motor	Mitsuba 250 W	Mitsuba 440 W	

# PRESENTATION OF THE 4 STROKE INJECTION SYSTEM (EFI)

## PRESENTATION OF THE 4 STROKE INJECTION SYSTEM (EFI)

### *Synoptics*

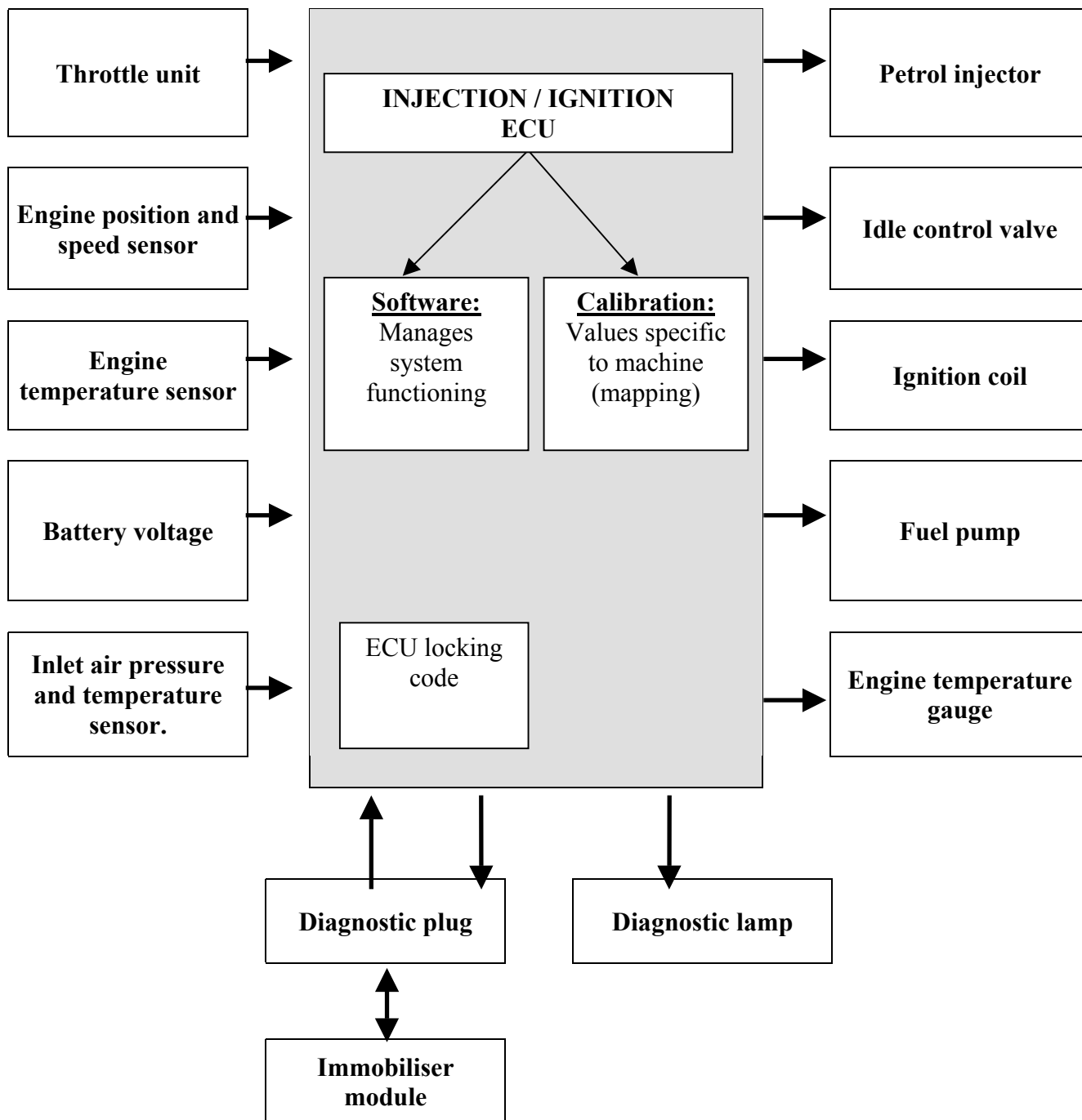

## DIAGNOSTIC TOOL

### Presentation

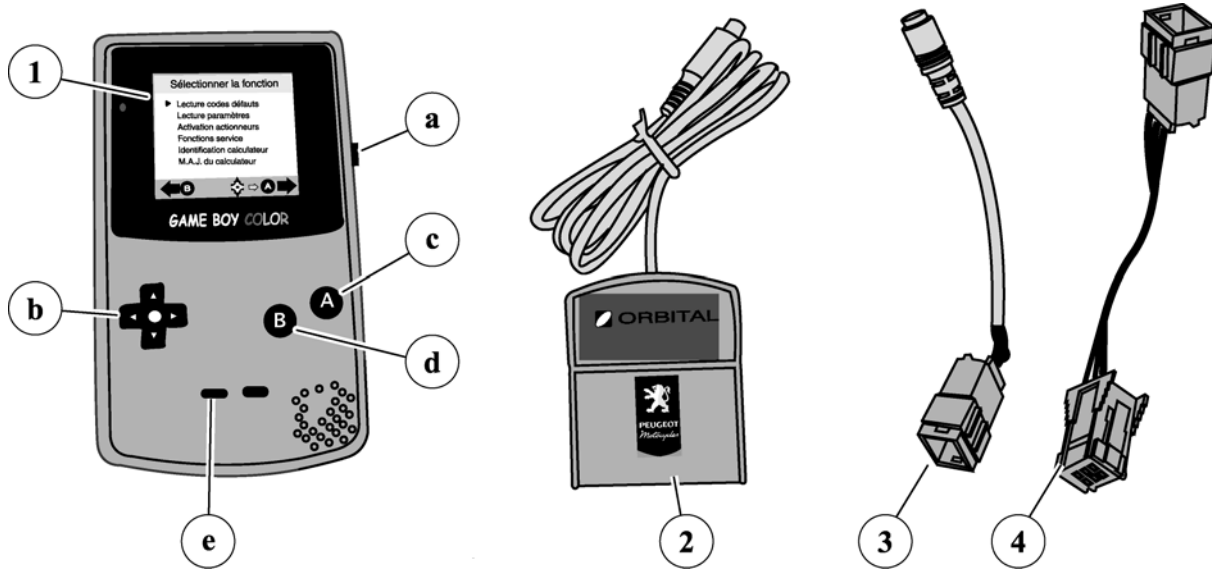

1 - A screen, a Nintendo © Game Boy™ Color console

a - on/off button

b - arrows: select key

c - button A: confirm button

d - button B: return button

e - select button: for help

2 - Cartridge, containing the software for dialog between the machine and the screen

3 - Interface cable between the machine and the tool for diagnostic of the 4-stroke injection system (EFI)

4 - Interface cable between the machine and interface cable (3) for diagnostic of the ABS/PBS system

## DIAGNOSTIC TOOL

### Connection of the diagnostic tool

1. Turn on the ignition (to unlock the ECU and authorise engine starting)
2. Remove the diagnostic plug loop (1)

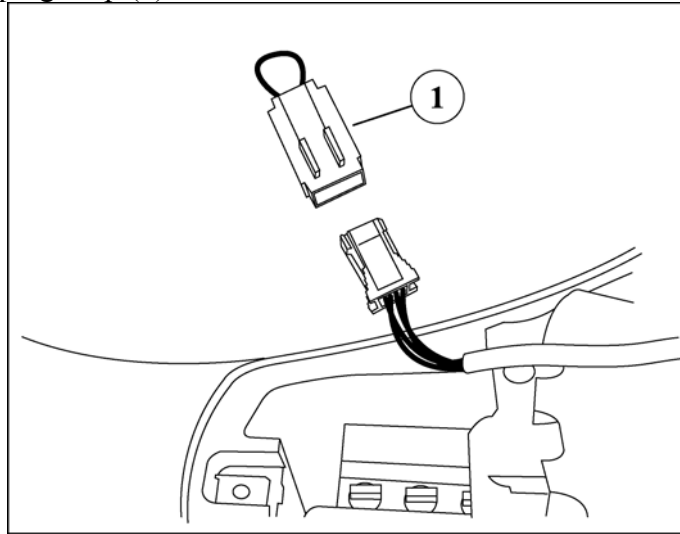

3. Connect the diagnostic tool to the machine using:

a - Interface cable (2) for EFI system diagnostic

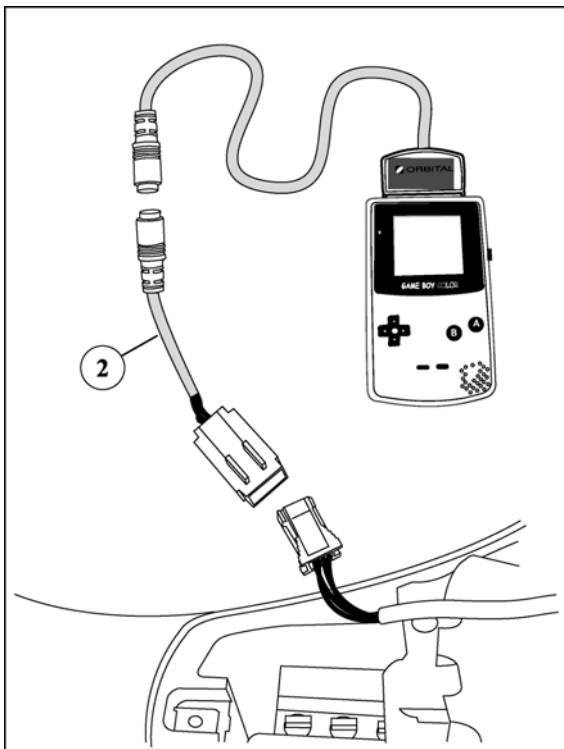

b - Interface cable (2) + special interface (3) ref: 756449 for diagnostic of the ABS/PBS system

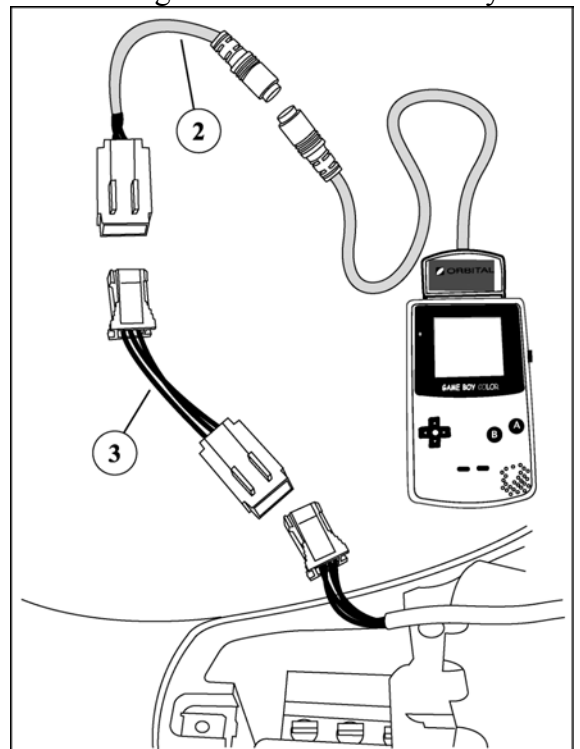

4. Turn on the diagnostic tool.

### Note:

**Never forget to re-connect the diagnostic plug loop. The loop provides the link between the immobiliser module and the injection/ignition ECU, and is essential to be able to start the engine**

## SPECIAL IMPORTANT POINTS

### **SPECIAL IMPORTANT POINTS**

#### *Fuel system*

**Before commencing work, clean the power unit.**

**The injection system is composed of precision components and cannot withstand impurities. Perfectly clean working conditions are therefore essential.**

#### **Note:**

Before carrying out any work, leave the engine to cool for a minimum of 2 hours.

Petrol is highly inflammable, do not smoke in the working area and avoid proximity to flames or sparks.

Work in a clear and well-ventilated area.

**The fuel pipes must be changed if they show signs of wear, cracks, etc.**

**Moreover, the hoses and clips are specific and must only be replaced by the original genuine parts**

## TIGHTENING TORQUES

### TIGHTENING TORQUES

#### 50 cc Engine

Cylinder head	1.2 m.daN
Cylinder casings	1 m.daN
Covers	1 m.daN
Inlet manifold	1 m.daN
Starter motor	1 m.daN
Rotor	4 m.daN
Stator	1 m.daN
Engine speed sensor.	1 m.daN
Turbine	1 m.daN
Drive pulley	4 m.daN
Driven pulley	4.5 m.daN
Spark plug	1 m.daN
Compressor	0.65 m.daN
Injection rail	0.65 m.daN





#### 125-150 cc Engine

Cylinder head	2.3 m.daN
Cylinder casings	1 m.daN
Covers	1 m.daN
Starter motor	1 m.daN
Rotor	7 m.daN
Stator	1 m.daN
Engine speed sensor.	0.65 m.daN
Drive pulley	7 m.daN
Driven pulley	7 m.daN
Spark plug	1 m.daN
Injection rail	1 m.daN

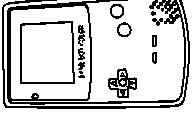
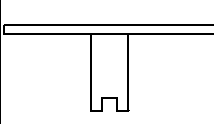
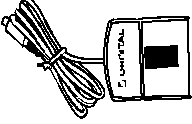
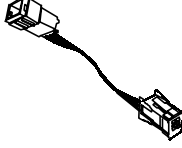
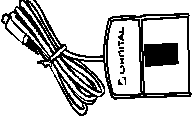

## SPECIAL TOOLS

### SPECIAL TOOLS

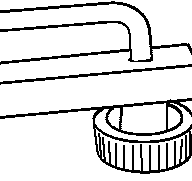
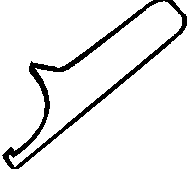
	Tool N°	Description	Used with			
	750539	Tie-wrap pliers			756017	Petrol injection power supply harness TSDI
	755878	diagnostic tool (Color Gameboy)	755806 755807		756076	Tank gauge spanner EFI
	755806	French cartridge	755878		756449	ABS/PBS interface cable for diagnostic tool
	755807	Export cartridge	755878			755878 755806 755807
	755990	Diagnostic tool update software	755878 755806 755807			
	755996	Hose clamp				
	756056	Tank ring spanner				

## INSTRUMENT PANEL

### INSTRUMENT PANEL

#### Warning lights description and meanings

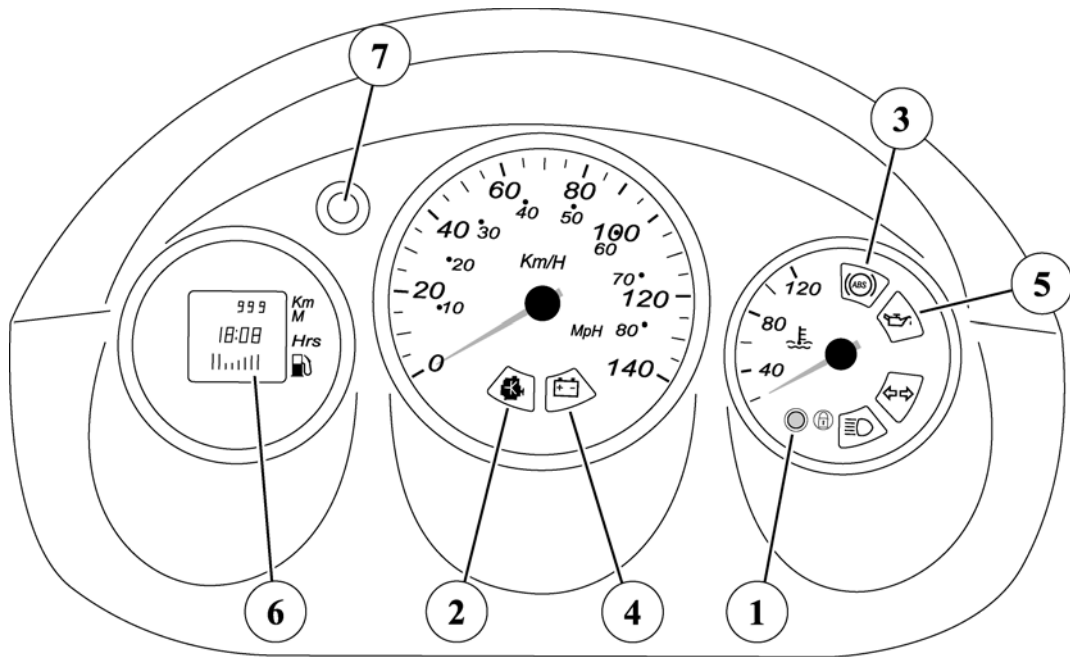

**Note:** The above diagram shows the Elystar 125-150 cc speedo  
On the 50 cc Elystar, there is no the engine temperature gauge and ABS/PBS warning light

When ignition is turned on:

- 1 - The coded immobiliser diagnostic LED comes on (1) and goes off after 0.5 seconds  
If there is an immobiliser fault, the LED flashes several times depending on the fault detected then stays on
- 2 - The EFI (Electronic Fuel Injection) or TSDI (Two Stroke Direct injection) diagnostic warning light (2) comes on then goes off when the engine is started  
If there is an injection system fault, the lamp flashes or stays on
- 3 – The ABS/PBS (Anti Blocking System/Powered Braking System) diagnostic warning light (3) comes on then goes off once the vehicle is on the move (over 5 km/h) (Elystar only)  
If there is an ABS/PBS fault, the lamp stays on
- 4 - The battery charge light (4) does not come on  
However, this warning light can come on at under 11.6 V or over 15.8 V to show there is a fault in the battery charging circuit
- 5 - The oil pressure warning light (5) comes on then goes off when the engine starts. This warning light comes on when under 0.5 bar to indicate a drop in engine oil pressure (stop the machine as quickly as possible) (on the Elystar 50 cc, this warning light is used for the separate lubrication system oil level, and comes on 3 seconds after turning on the ignition)

## INSTRUMENT PANEL

### Changing the speedo units

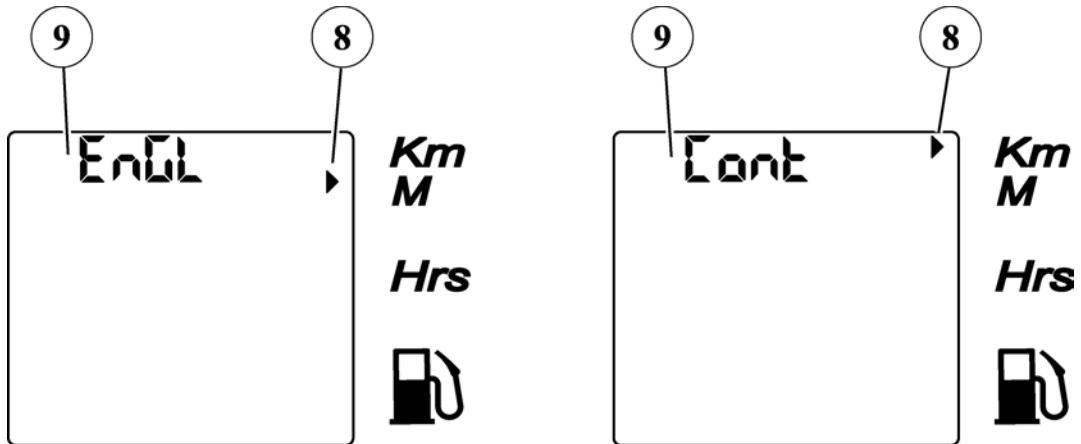

**Note:** This function is available if the machine has done under 10 kms

The choice of distance unit (km/miles) is by pressing the control button (7) before turning on the ignition and holding it down until the display lights up.

Unit selection is by pressing the control button (7), the arrow (8) is positioned against the unit selected and "Engl" or "Cont" is displayed at (9)

The choice is confirmed by pressing the control button (7) for more than 2 seconds

### Service function

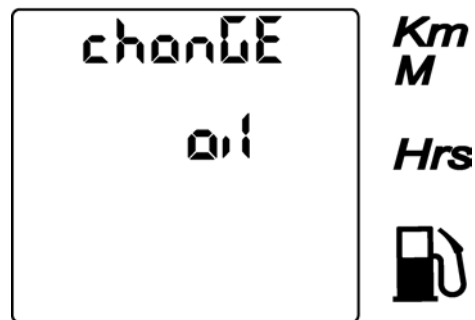

**Note:** This function is only available on Elystar 125-150 cc and if the machine has covered over 10 kms

As from 5000 kms and once this distance is exceeded, when the ignition is turned on, the message "change oil" appears for 10 seconds in place of the clock display

This display tells the customer that his machine is due for its first service.

After servicing the machine, the service counter is reset by pressing on the control button (7) before turning on the ignition

And so on, after every 5000 km covered, the same display is shown to remind the customer that servicing is due (5000 kms after the previous service counter reset)

## TRANSPONDER IMMOBILISER

### TRANSPONDER IMMOBILISER

#### **Precautions:**

Check that the diagnostic plug loop is fitted. The loop provides the link between the immobiliser module and the injection/ignition ECU, and is essential to be able to start the engine

If the loop is not fitted, the transponder LED diagnostic is always the same (no link between the immobiliser and the ECU)

**Note:** Fitting of a 5 k $\Omega$  resistive suppressor along with a resistive spark plug is essential for the proper functioning of the engine

#### *System programming*

The machine is supplied with a notched key (master) and a black key

The system is programmed in the factory

It is possible to program up to 7 black keys

The key memory procedure is the same as the AEC400 and ACI100 system

#### *Reminder of the key memory procedure*

1. Using the master key, set the ignition to on, and when the LED lights, turn off the ignition
2. Within a maximum of 15 seconds of cutting off the ignition with the master key, turn on the ignition with the black key, and when the LED comes on turn off the ignition (repeat the operation for each black key to be memorised (maximum of 7 black keys))
3. Within a maximum of 15 seconds of turning off the ignition with the last key memorised, turn on the ignition with the master key, and when the LED comes on, turn off the ignition

#### *Key memory check*

Using the master key, turn on the ignition, the LED on the instrument panel comes on for 0.5 seconds and flashes a number of times. The number of flashes indicates the number of keys memorised, including the master key

#### *Diagnostic LED readings*

There are three successive diagnostic LED lighting phases when the ignition is turned on with a black key

#### **Phase 1: System status**

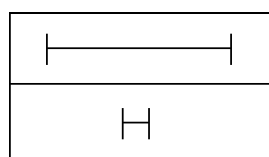

Lights for 2 seconds: Immobiliser not programmed

Lights for 0.5 seconds: Immobiliser programmed

#### **Phase 2: Diagnostic**

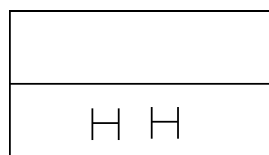

Does not light: No fault detected

Lights 1 to 4 times for 0.5 seconds Fault detected

#### **Phase 3: Starting enabled**

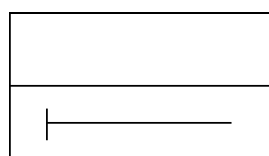

Does not light: Starting enabled (if engine does not start, see troubleshooting chart)

Light stays on Starting not enabled

## TRANSPONDER IMMOBILISER

### *Additional information*

Before carrying out any work on the transponder immobiliser, have the machine master key and black key to hand.

If the engine will not start, a first diagnostic may be carried out using the LED before checking the other parts of the ignition system.

**Note:** Do not remove the diagnostic plug loop







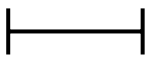

In case of a fault, do not use an immobiliser module or ECU from another machine to carry out tests. The keys, immobiliser module and ECU programmed on another machine form an assembly, are linked by a code and must under no circumstances be separated.

**Important:** If an ECU is changed without memorising the keys, do not turn on the ignition more than 16 times if the diagnostic loop is disconnected as beyond this number, the ECU immobiliser function is erased.

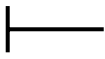
## TRANSPONDER IMMOBILISER

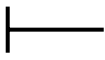
### Troubleshooting chart

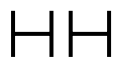
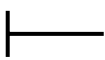
If the engine will not start, a first diagnostic may be carried out using the LED before checking the other parts of the ignition system

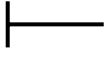
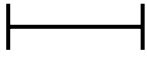
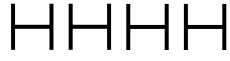
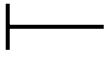
<b>TEST TO BE CARRIED OUT ONLY WITH THE BLACK KEY</b>				
<b>LED SIGNAL</b>			<b>DISPLAYS</b>	<b>SOLUTIONS</b>
<b>PHASE 1</b>	<b>PHASE 2</b>	<b>PHASE 3</b>		
2 s 			Blank immobiliser connected to a blank ECU	Program the system using the keys
0.5 s 			Blank ECU connected to a programmed immobiliser	Disconnect the diagnostic plug loop, turn on the ignition with the master key and start the engine If OK, connect the diagnostic plug loop, turn on the ignition with the master key and start the engine or turn on the ignition for 3 seconds to memorise the keys in the system
0.5 s 		Permanent 	Black key and programmed immobiliser module from another machine	Refit the immobiliser and the original keys or replace by a new one and program the system using the original keys
0.5 s 	0.5 s 	Permanent 	No diagnostic plug loop or faulty immobiliser/ECU link	Refit the diagnostic plug loop or check the interface wire between the immobiliser and the ECU
0.5 s 	0.5 s 	Permanent 	Antenna disconnected or faulty Key without transponder	Check the antenna connection and resistance (17 Ω) Change the key
0.5 s 	0.5 s 	Permanent 	Wrong or faulty key or programmed immobiliser from another machine	Refit the original immobiliser or replace by a new one and program the system using the original keys
2 s 	0.5 s 	Permanent 	Blank immobiliser connected to a programmed ECU	Program the system using the keys

# TRANSPONDER IMMOBILISER

## Ignition principle schematic

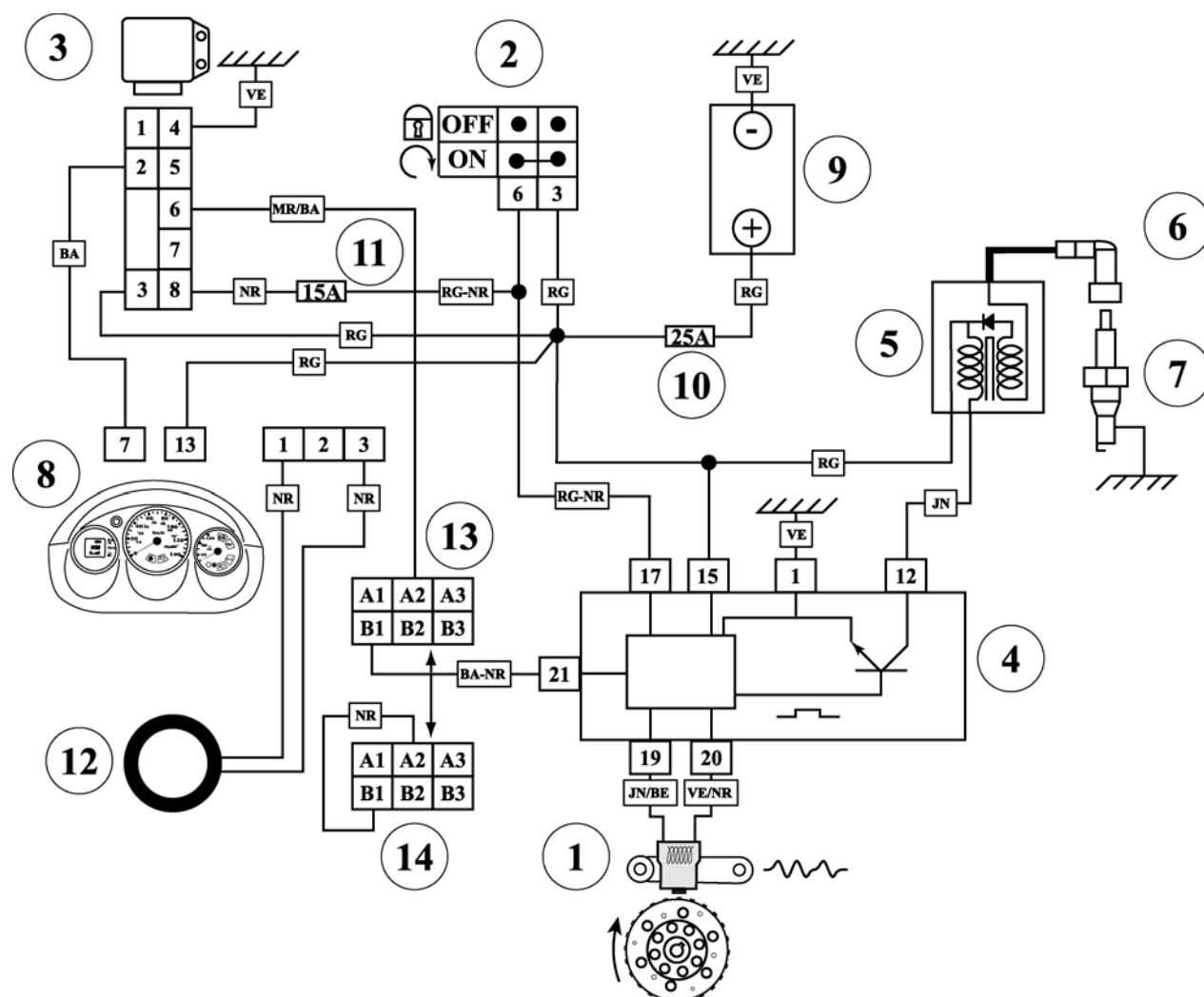

1. Engine position sensor
2. Ignition switch
3. Immobiliser module
4. Injection ECU
5. HT coil
6. Resistive suppressor
7. Resistive spark plug
8. Instrument panel LED
9. Battery
10. 25A fuse
11. 15A fuse
12. Transponder antenna
13. Diagnostic plug
14. Diagnostic plug loop

BA	White
BA/NR	White/Black
JN	Yellow
JN/BE	Yellow/Blue
MR/BA	Brown/White
NR	Black
RG	Red
RG/NR	Red/Black
VE	Green
VE/NR	Green/Black

## SPECIAL FEATURES OF THE 2<sup>nd</sup> GENERATION SYNCHRO BRAKING CONCEPT

### SPECIAL FEATURES OF THE 2<sup>nd</sup> GENERATION SYNCHRO BRAKING CONCEPT

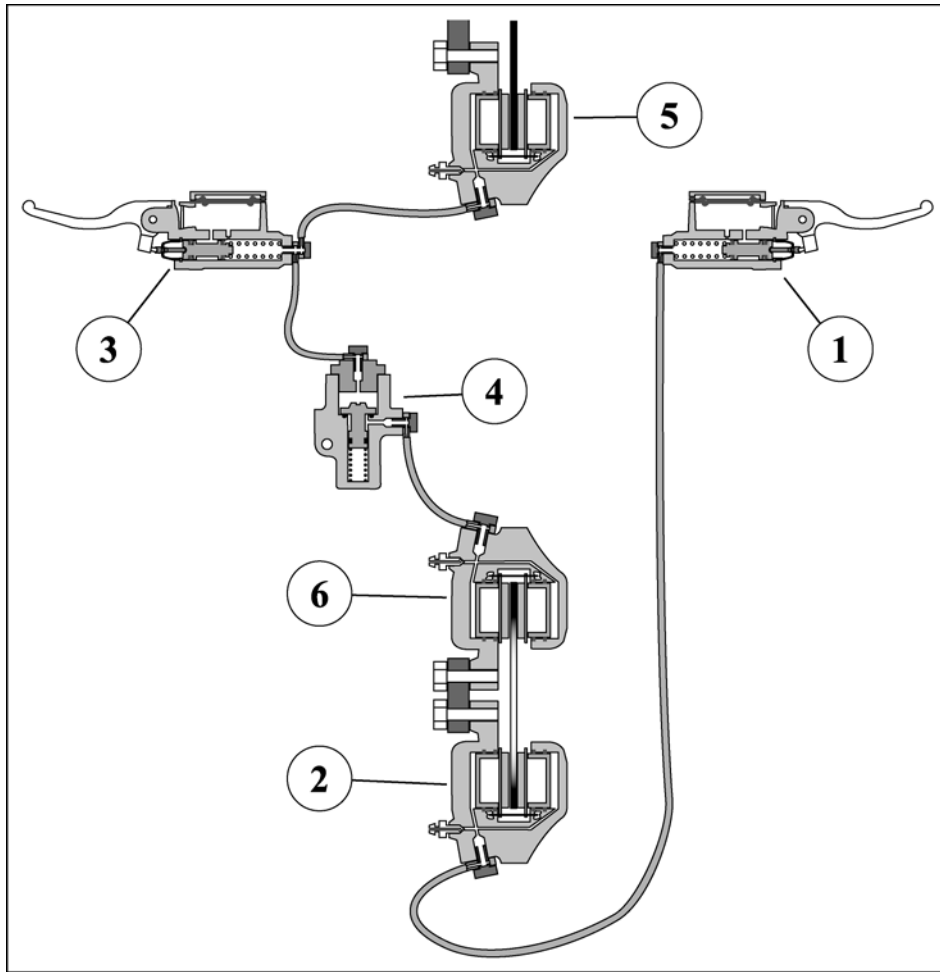

#### 1. Right-hand brake lever

This is a conventional master cylinder which operates the rear brake caliper (2). This circuit acts as the **emergency brake**.

#### 2. Emergency circuit rear brake caliper

This is a fixed two opposed piston caliper.

#### 3. Left-hand brake lever

This is a conventional dual output master cylinder operating the main circuit front caliper (5) and the rear caliper (6) simultaneously. This circuit acts as the **main brake**.

#### 4. Rear braking limiter

This is a valve which limits the braking pressure to main circuit rear caliper used to prevent rear wheel lock-up under hard braking on a dry surface.

#### 5. Front brake caliper

This is a fixed two opposed piston caliper.

#### 6. Main circuit rear brake caliper

This is a fixed two opposed piston caliper.



### WORKING ON 4-STROKE INJECTION SYSTEMS

#### To remove the fuel pump

**Note:** Before carrying out any work, leave the engine to cool for a minimum of 2 hours. Petrol is highly inflammable, do not smoke in the working area and avoid proximity to flames or sparks.

Work in a well ventilated area

- Remove the ignition key
- Remove the lower panel (2) fixing screws (1)
  
- Remove the rear panel (4) fixing screws (3)
- Remove the rear panel by pulling it rearwards
  
- Remove the side panel assembly (7) 6 screws (5) and the 2 plasti-rivets (6)
- Release the saddle opening catch
- Remove the side panel assembly

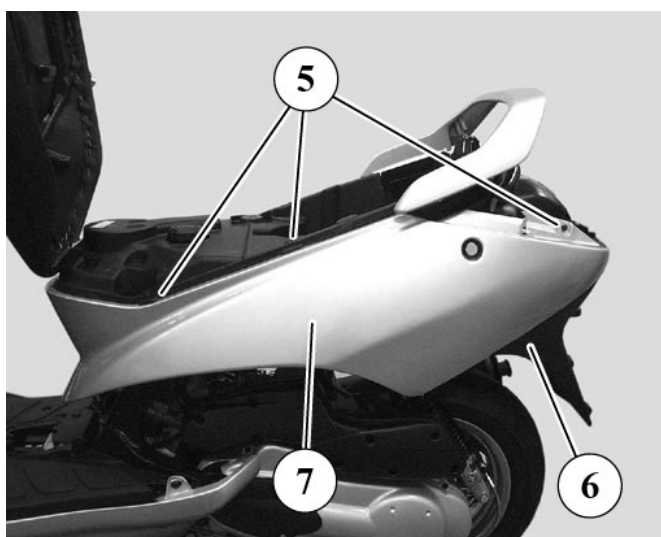
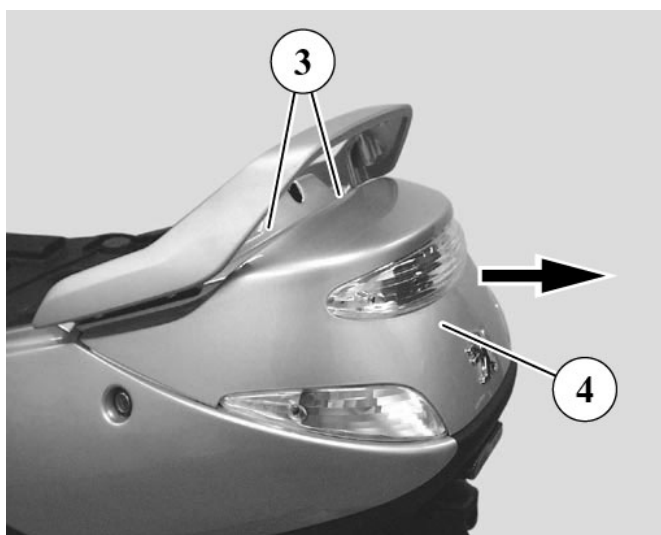
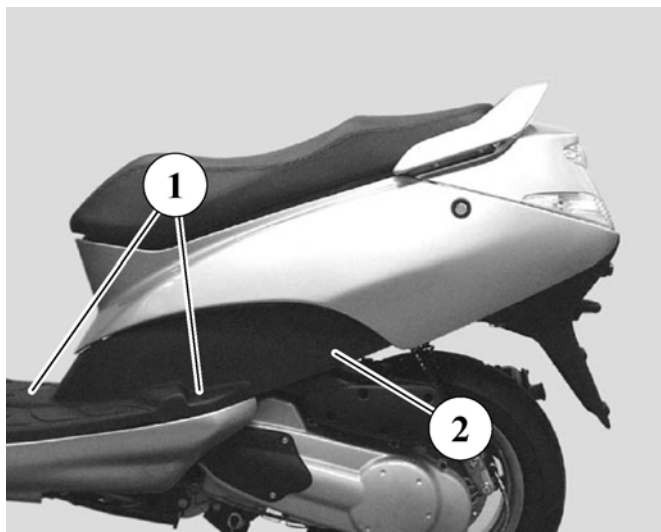

## WORKING ON 4-STROKE INJECTION SYSTEMS

- Remove the mudguard (10) 3 screws (8) and the 2 screws (9) (in the storage compartment)
- Remove the mudguard without removing the boa lock if it is not necessary

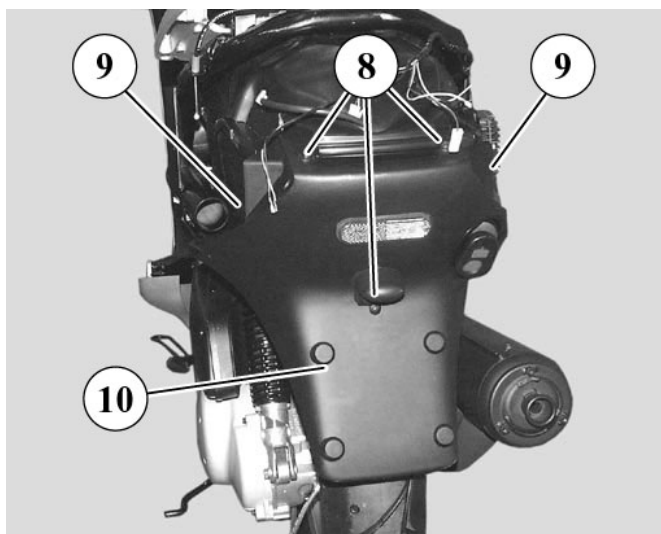

- Remove the storage compartment (12) 5 screws (11)
- Remove the storage compartment with the saddle

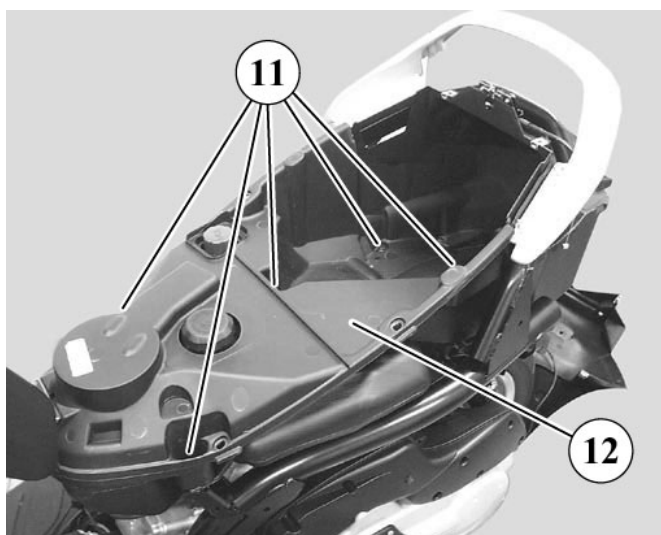

- Disconnect the gauge (1)
- Disconnect the fuel gauge (2)

**Note:** Put a rag over the fuel pipe (3) to catch any fuel splashes

- Disconnect the fuel feed pipe (3) and the regulator vacuum pipe (4)

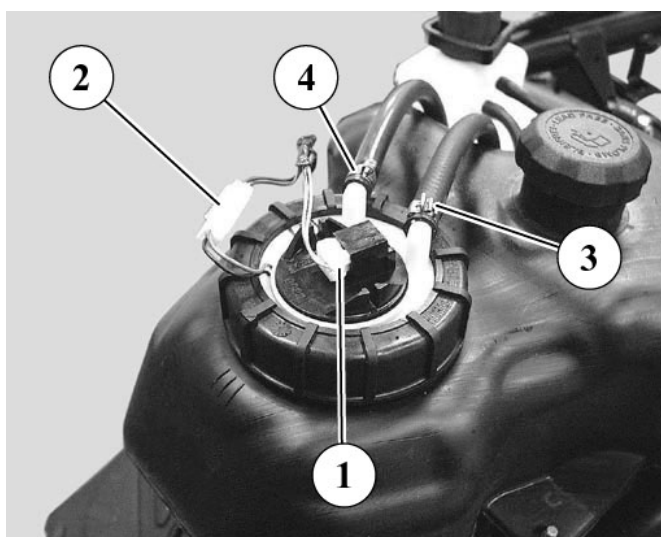

## WORKING ON 4-STROKE INJECTION SYSTEMS

- Remove the fuel gauge (5) with its seal using tool P/N 756076 (and press on the tool in order to squash the rubber seal and unscrew one quarter of a turn)

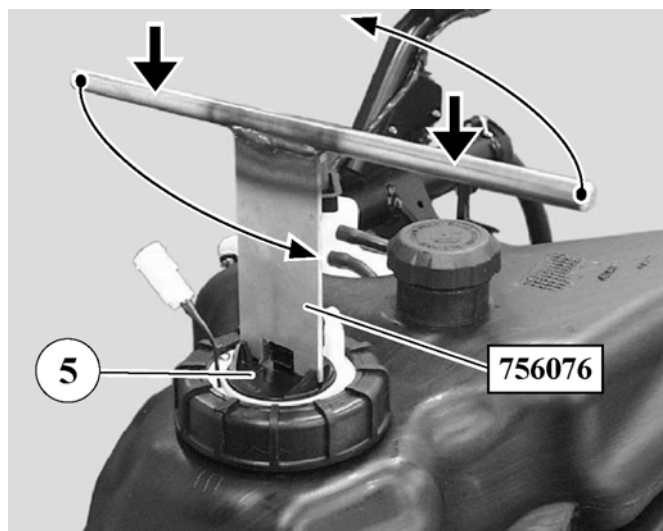

- Unscrew and remove the fuel pump assembly (6) with its seal using tool P/N 756056

**Note:** None of the components, fuel pump, pressure regulator and strainer are removable. It is only possible to clean the outside of the strainer

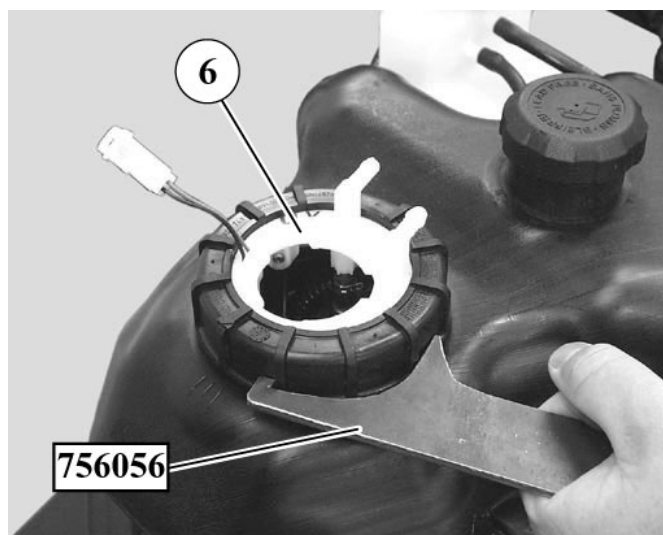

**Reassembly:** Re-assemble in the reverse order to dismantling

- Tighten the fuel pump with the ring spanner P/N 756056 in order to line up the arrow (A) with the centre mark (B) on the tank
- Fit the fuel gauge with a new seal

**Check:** Using the diagnostic tool, check for fault codes, clear them if necessary

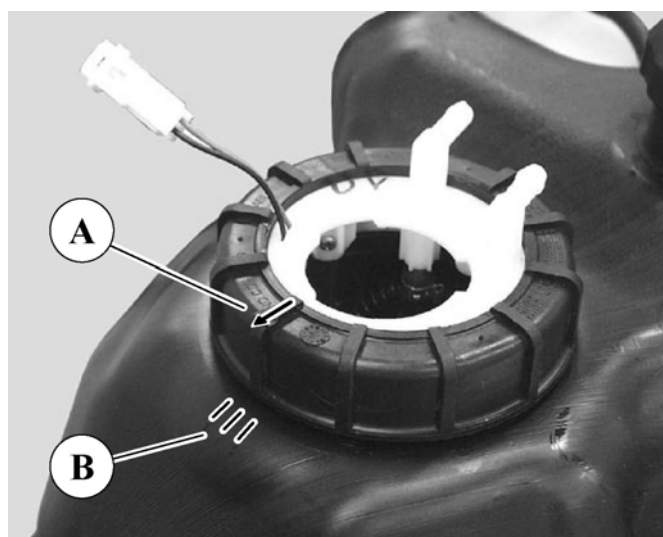

## WORKING ON 4-STROKE INJECTION SYSTEMS

### To remove the air injector

- Remove the ignition key
- Remove the side panels
- Remove the injector assembly (1)

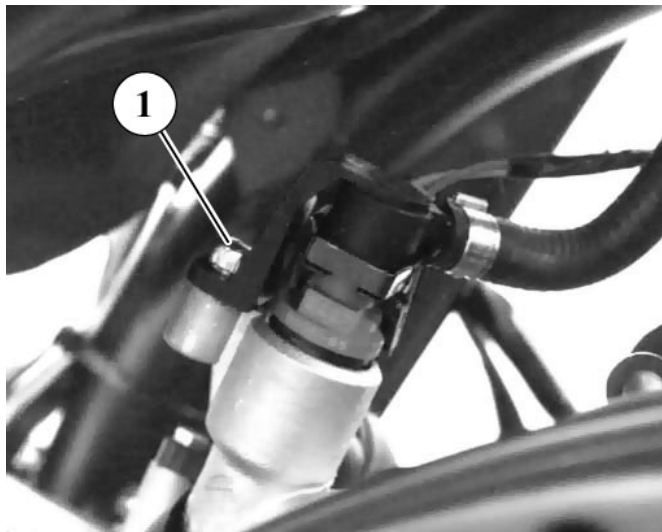

- Disconnect the fuel injector (2)
- Fit the hose clamp P/N 755996 to the feed pipe (3)
- Disconnect the hose
- Remove the fuel injector (4)

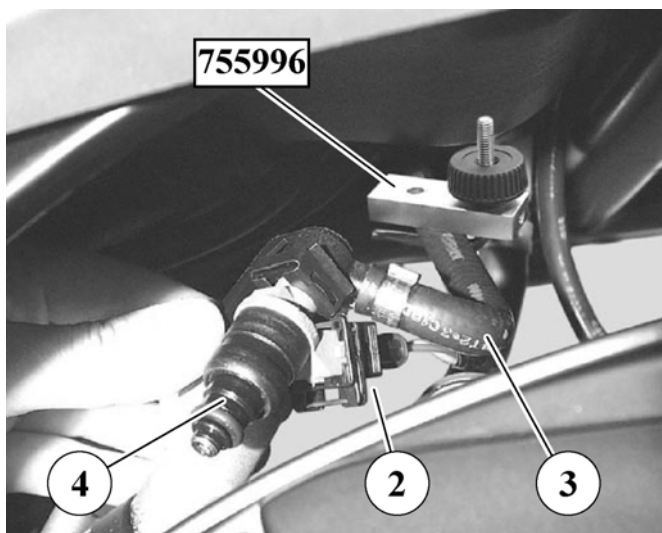

**Reassembly:** Re-assemble in the reverse order to dismantling

**Check:** Using the diagnostic tool, check for fault codes, clear them if necessary

## WORKING ON 4-STROKE INJECTION SYSTEMS

### To remove the throttle housing and idle valve

- Remove the ignition key
- Remove the battery covers
- Disconnect the atmospheric pressure sensor (1)
- Disconnect the oil vapour recycling hose (2)
- Slacken the screw-type clip (3) from the throttle housing lug and inlet silencer
- Remove the inlet silencer 2 fixing bolts (4)
- Remove the inlet silencer (5)

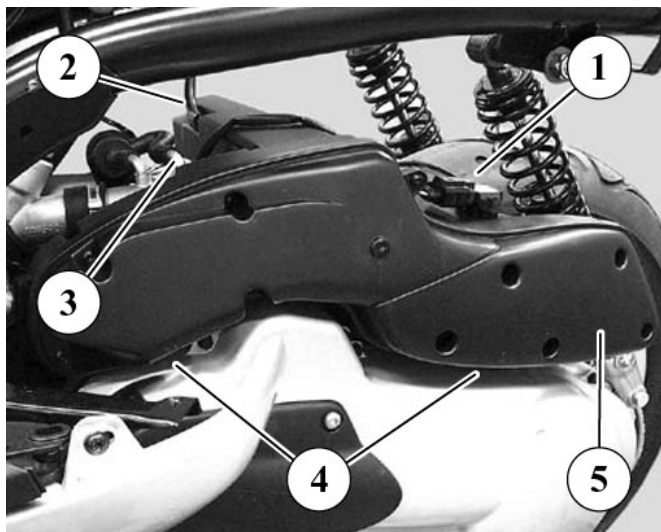

- Disconnect the throttle cable (6)
- Disconnect the throttle unit (7) and the idle valve (8)
- Unclip the clip type hose clip
- Remove the throttle unit

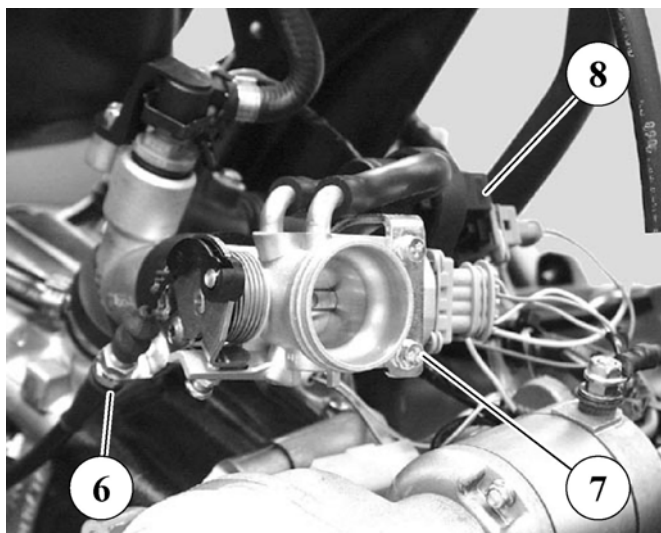

**Reassembly:** Proceed in reverse order to disassembly ensuring:

- the throttle unit positioning pin (A) is properly located in its housing on the inlet manifold
- the accelerator cable is properly tensioned
- Use the diagnostic tool to initialise the throttle unit (refer to the documentation "Using the Diagnostic Tool for the Injection Engine")

**Check:** Using the diagnostic tool, check for fault codes, clear them if necessary

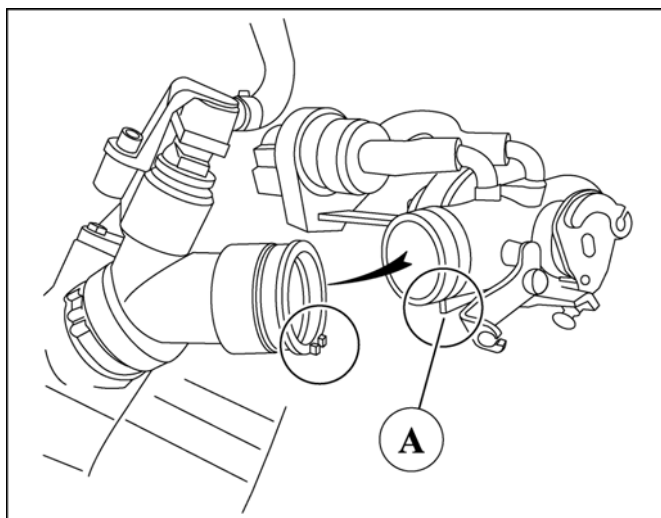

## WORKING ON THE ABS/PBS SYSTEM

### ABS/PBS diagnostic

To diagnose the ABS/PBS function:

- Turn on the ignition
- Remove the diagnostic plug loop
- Connect the diagnostic tool P/N: 755878 to the special interface cable P/N: 756449
- Connect the interface cable to the machine diagnostic plug

### Troubleshooting chart

1. Fault codes A (1, 3, 4, 7, 8, 21, 22, 27, 28, 30): ABS/PBS ECU internal faults  
Change the control unit and return it to Peugeot Motorcycles with the filled out parameter sheet
2. Fault codes B (5, 6, 11): Control unit power supply fault

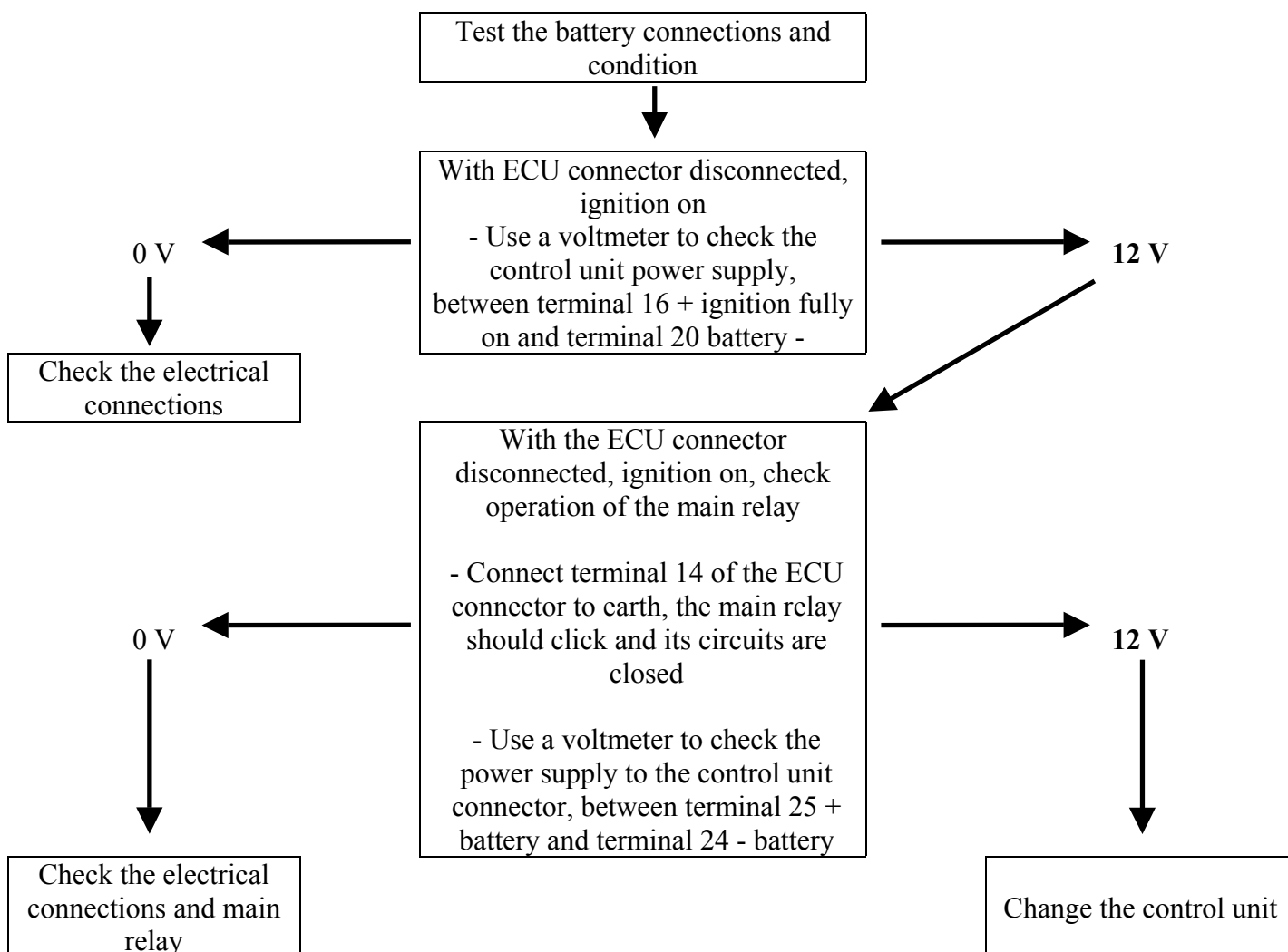

## WORKING ON THE ABS/PBS SYSTEM

### 3. Fault code 15: PIN code error

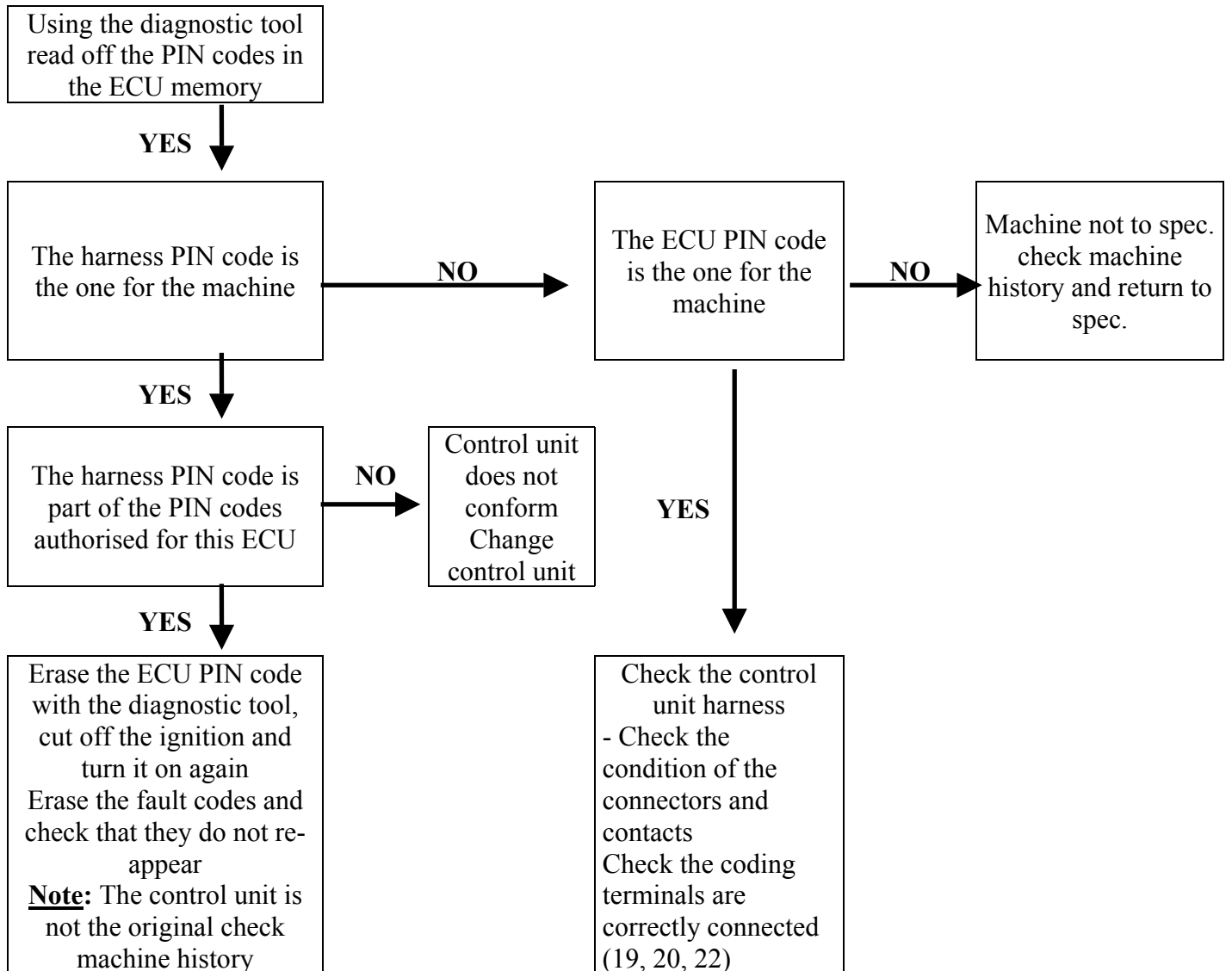

## WORKING ON THE ABS/PBS SYSTEM

### 4. Fault code 129: Wheel locking too long

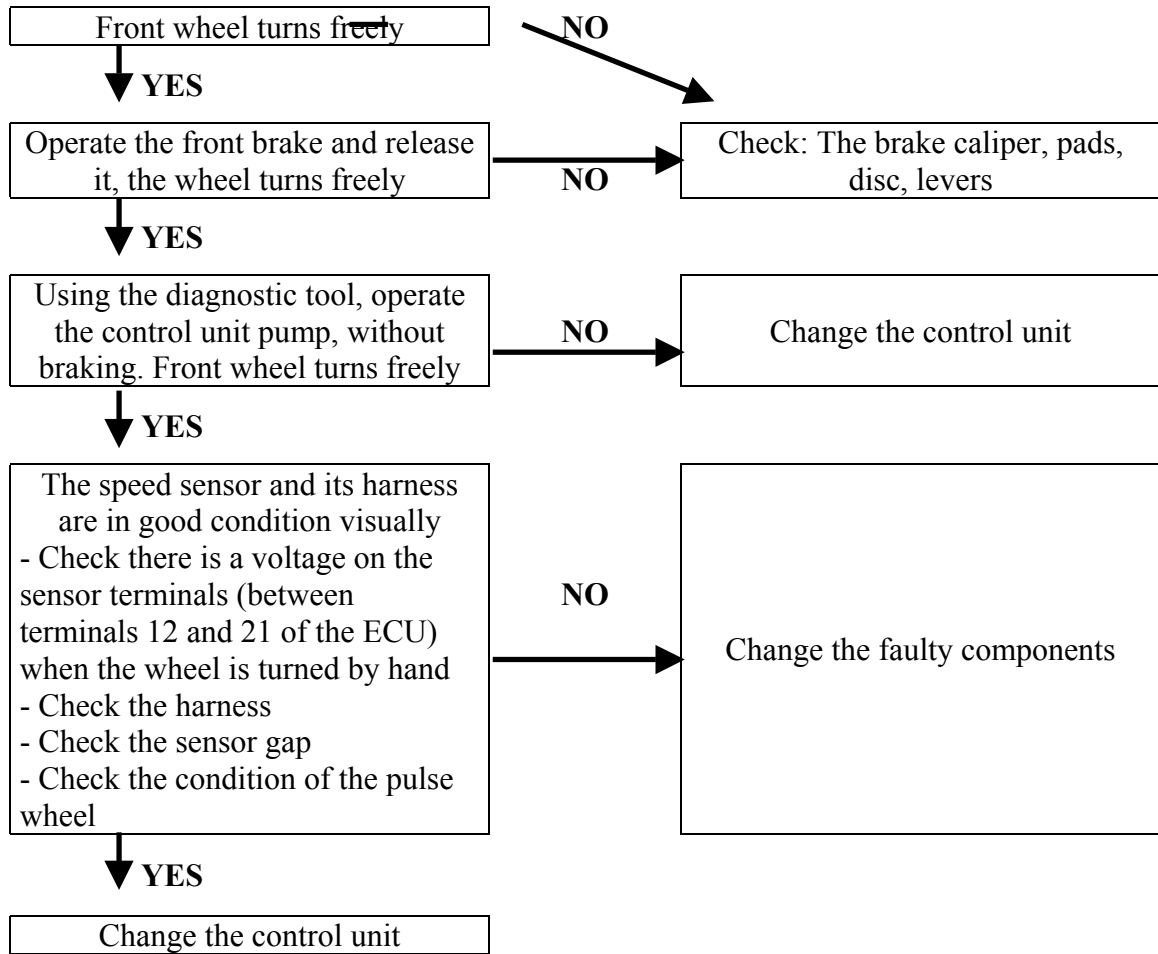

### 5. Fault code 130: No wheel speed information

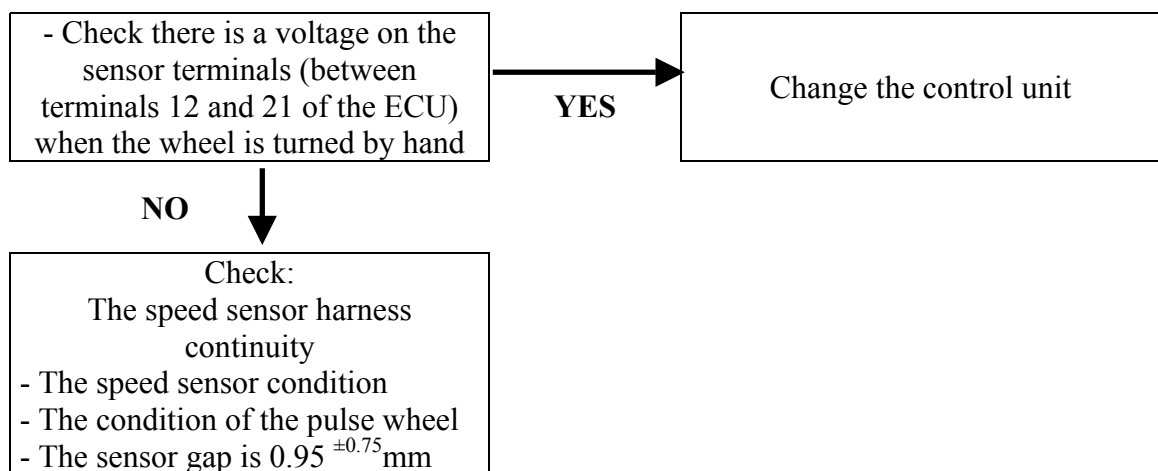



## WORKING ON THE ABS/PBS SYSTEM

### Incidents which cannot be detected by the ECU

These incidents are not detected by the ECU and do not show a fault code.

Loss of braking pressure, brake lever soft: (warning light off)

Checks:

- Check the brake fluid level in the levers
  - Check operation of the conventional part of the brakes, calipers, pads, unions, etc
  - Check the brake fluid level in the control unit reservoir
  - Bleed the brake system and check there is no air in the circuit
  - Check the electrical power supply to the control unit, battery charge, harness connections, etc
- if the checks prove OK and the fault persists, change the control unit

Harsh and non-progressive braking: (warning light off)

- Change the control unit

Warning light does not go off at a speed of over 5 km/h but goes off after braking and no fault code: (warning light on)

Checks:

- Check the right and left contactors
- Check the brake contactor harness, continuity, isolation
- Check the warning light harness, continuity, isolation
- Check the speed sensor, wrong gap, pulse wheel distorted, sensor faulty, etc
- Check the control unit electric motor, terminal 15 and terminal 18

If these checks prove OK and the fault persists, change the control unit

Warning light does not go off at a speed of over 5 km/h even after braking and no fault code: (warning light on)

Checks:

- Check the right and left contactors
- Check the brake contactor harness, continuity, isolation
- Check the warning light harness, continuity, isolation

If these checks prove OK and the fault persists, change the control unit

Electric pump operates permanently with no effect on brakes: (warning light on)

Checks:

- Cut off the ignition and turn on again
- Check the right and left contactors
- Check the brake contactor harness, continuity, isolation
- Check the warning light harness, continuity, isolation
- Check the speed sensor, wrong gap, pulse wheel distorted, sensor faulty, etc
- Check the control unit electric motor, terminal 15 and terminal 18

If these checks prove OK and the fault persists, change the control unit



## WORKING ON THE ABS/PBS SYSTEM

Warning light is off when ignition is turned on:

Checks:

- Check the warning light harness, continuity, isolation
- Check the warning light functions.

If these checks prove OK and the fault persists, change the control unit

Electric pump does not operate when braking at a speed of over 5 km/h: (warning light off)

Checks:

- Check the right and left contactors
- Check the brake contactor harness, continuity, isolation
- Check electrical power supply to the control unit, terminal 30

If these checks prove OK and the fault persists, change the control unit

**Note:** When the machine is stationary, at a traffic light for example, the control unit assistance pump automatically stops after a few seconds of being stationary, in spite of operating the levers (except for early production machines on which the pump functions continually).



# WORKING ON THE ABS/PBS SYSTEM

*ABS/PBS principle diagram*

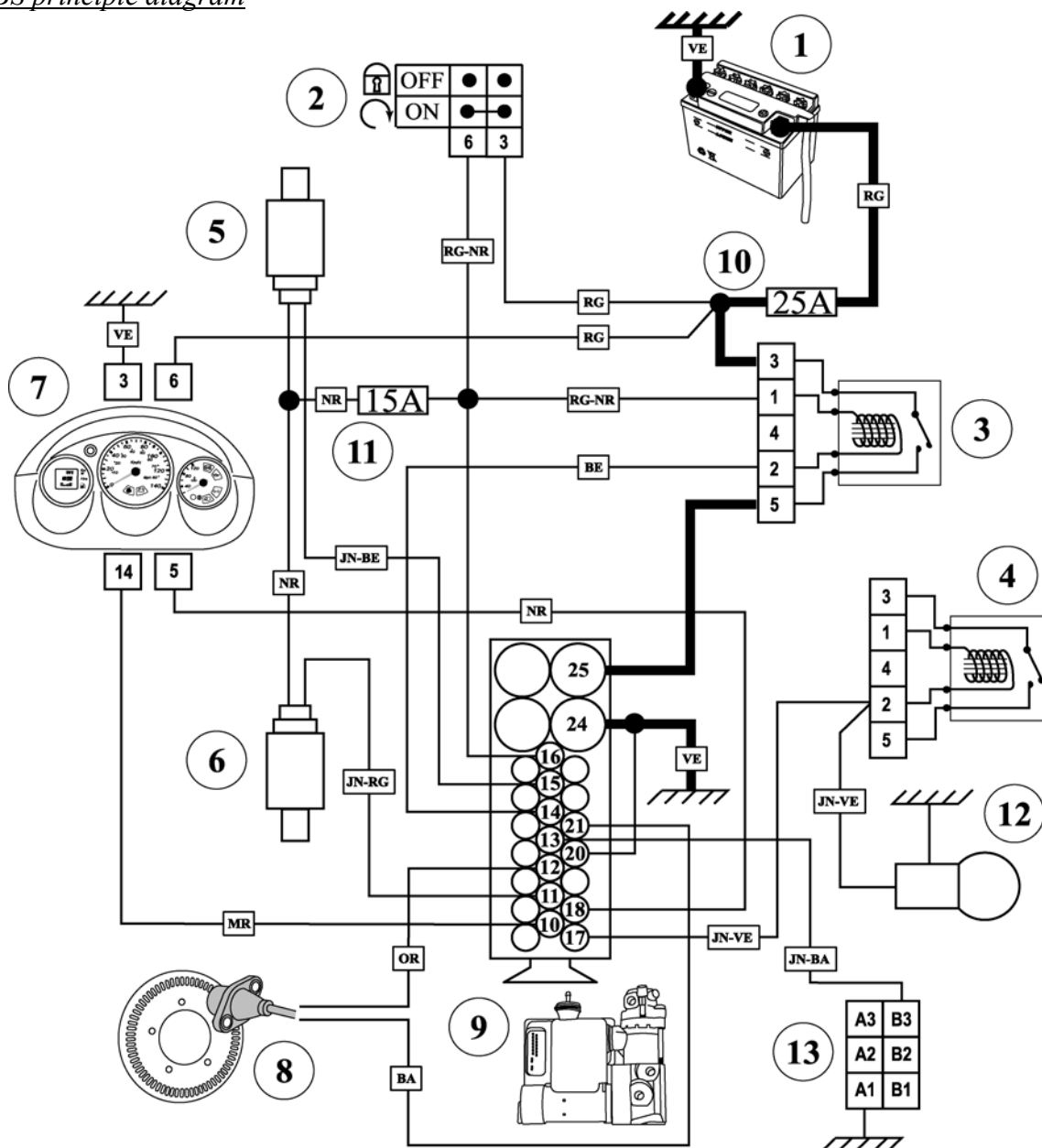

1. Battery
2. Ignition switch
3. Main relay
4. Starter motor relay:
5. RH brake contactor
6. LH brake contactor
7. Instrument panel
8. Speed sensor and pulse wheel
9. Control unit
10. 25A fuse
11. 15A fuse
12. Brake light
13. Diagnostic plug

BA	White
BE	Blue
JN/BA	Yellow/White
JN/BE	Yellow/Blue
JN/RG	Red/Yellow
JN/VE	Yellow/Green
MR	Brown
NR	Black
OR	Orange
RG	Red
RG/NR	Red/Black
VE	Green





SALES DIVISION  
NETWORK TECHNICAL INFORMATION

# PARAMETER MEASUREMENT SHEET

**ELYSTAR**  
ABS/PBS

Parameter reading

<b>MACHINE DETAILS</b>	
<b>VIN</b>	
<b>Mileage</b>	
<b>ECU identification</b>	
<b>ECU N°</b>	
<b>Software version</b>	
<b>Control unit version</b>	

**Fault codes found during check:**

PARAMETERS	Meas. 1 engine stopped	Meas. 2 driving	Standard values
Vehicle speed			0 to 120 km/h
Battery voltage			13.8 to 15 volts
LH brake light switch			On, off
RH brake light switch			On, off
pump			On, off
Harness PIN code			xxx
ECU PIN code			xxx
Possible ECU codes			xxx-xxx-xxx-xxx-xxx

Photocopy and sent to Peugeot Motorcycles in case of problem requiring help from our network training department



## WORKING ON THE ABS/PBS SYSTEM

### To remove the control unit

- Remove the ignition key
- Remove the handlebar upper cover (2) nine fixing bolts (1)

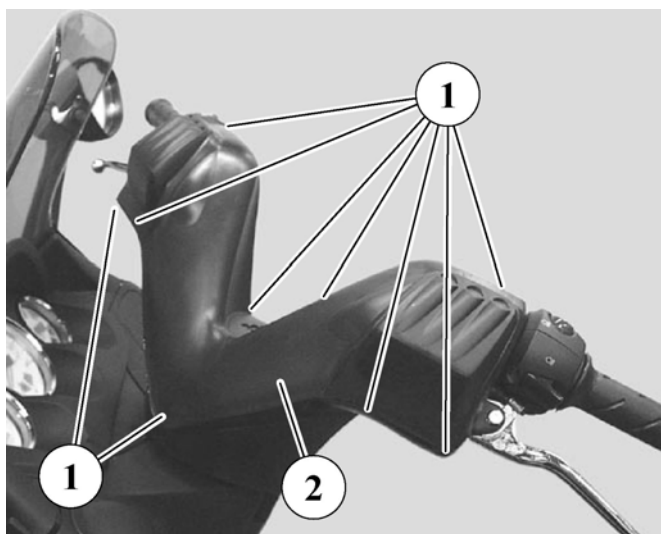

- Remove the lower panel (4) three fixing screws (3)

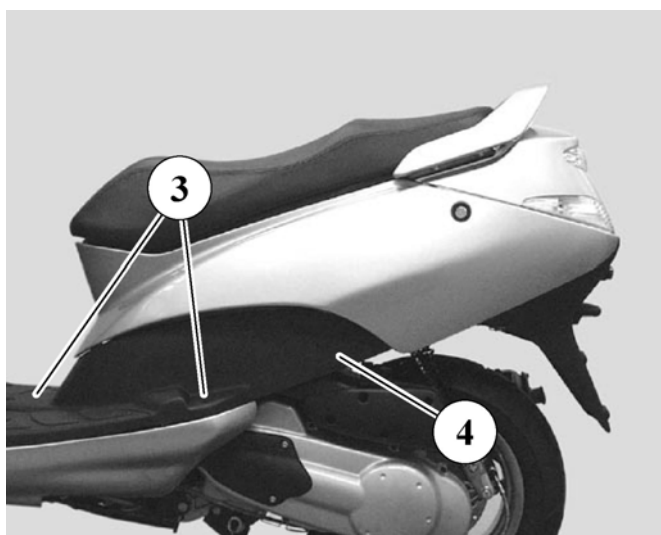

- Remove the bottom panel (6) four fixing bolts (5)

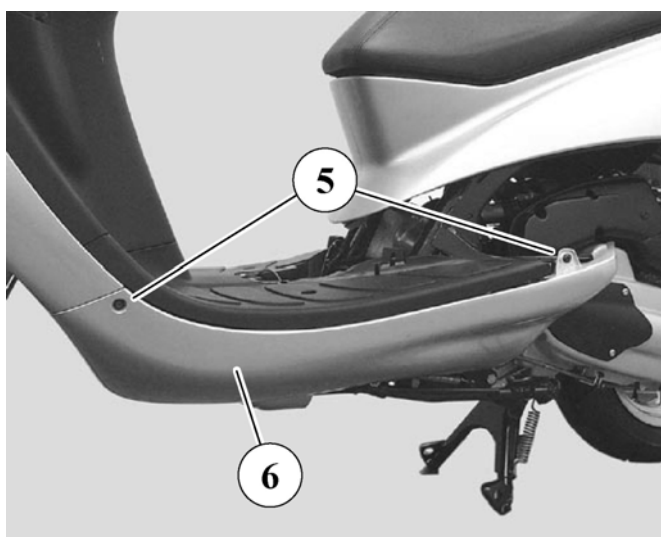

## WORKING ON THE ABS/PBS SYSTEM

-Remove the upper front legshield (8) 5 screws (7)

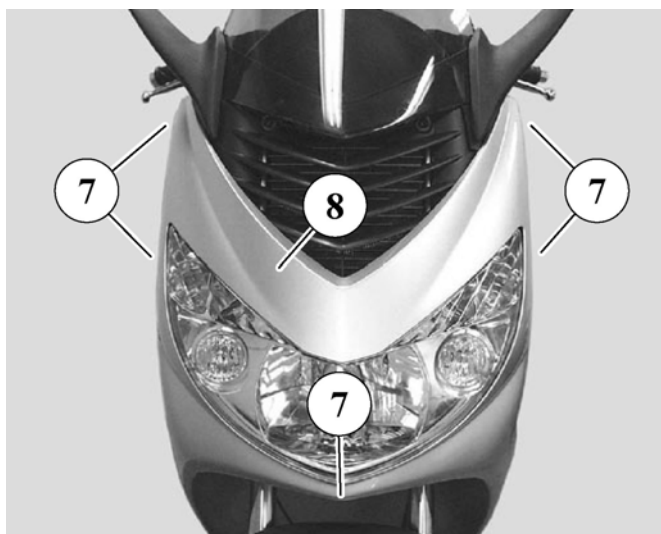

- Remove the lower legshield panel (10) two fixing screws (9)

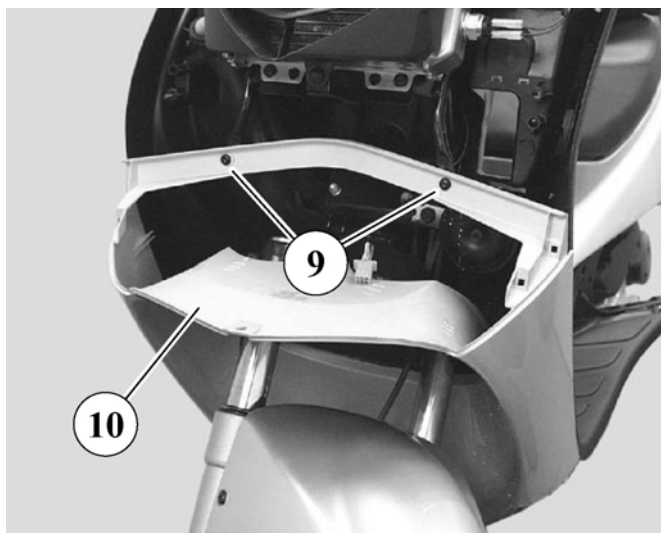

**Note:** Lock the right-hand lever 20 mm from the rest position (with a hook or cable-tie (11))  
This operation enables the circuit to be closed and avoids emptying the hydraulic hose when it is disconnected from the control unit. It also facilitates bleeding of the main circuit (left-hand brake)

Hook diagram, full scale 1

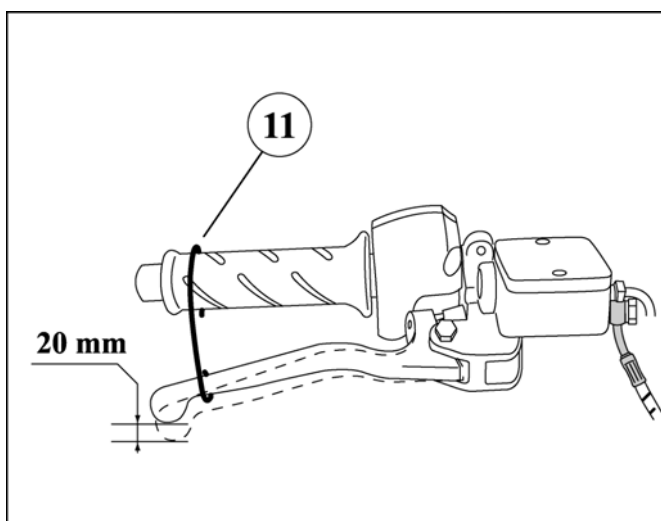
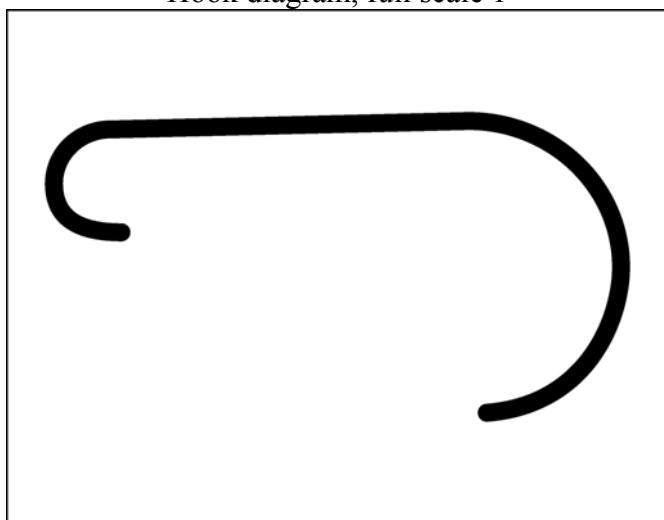

## WORKING ON THE ABS/PBS SYSTEM

- Protect any plastics which may be exposed to brake fluid splashes
- Pull the locking system (A) upwards to enable removal (B) of connector (12)
- Disconnect the control unit

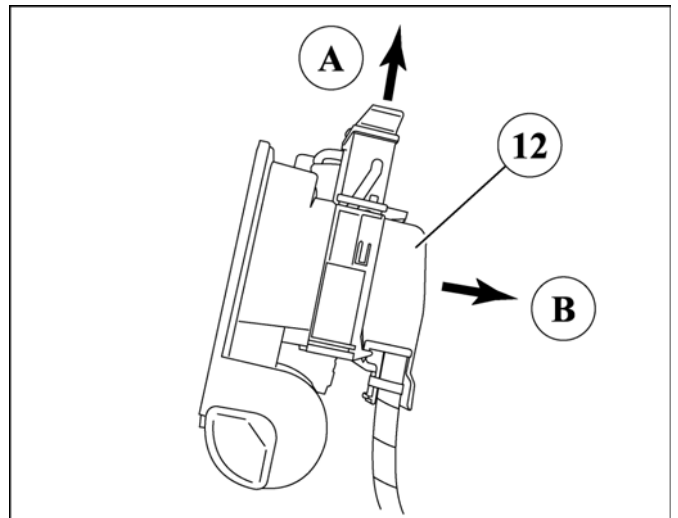

- Clamp the reservoir feed hose (13) with hose clamp P/N 755996
- Disconnect the feed pipe
- Disconnect the 4 hydraulic controls (14)

**Note:** Put a recipient under the control unit to catch the brake fluid  
Do not remove the master cylinder covers

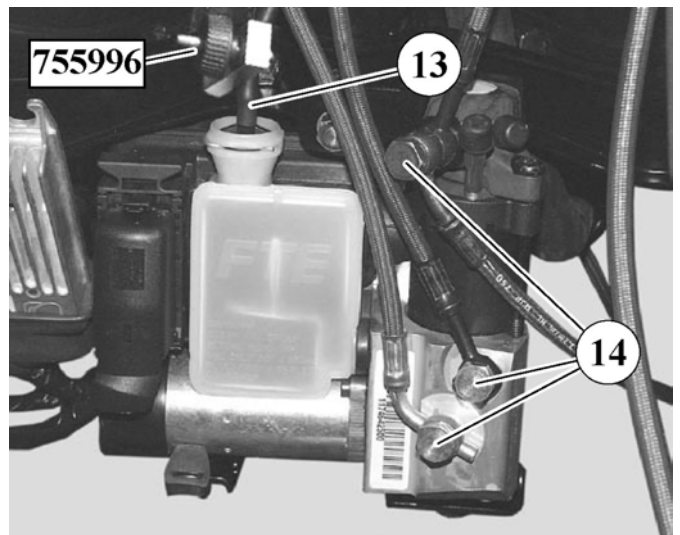

- Remove the control unit
- Remove the clip (15), cap (16) and filter (17) to drain off the reservoir

**Note:** The control unit must not be opened  
Only the manufacturer is authorised to work on this component

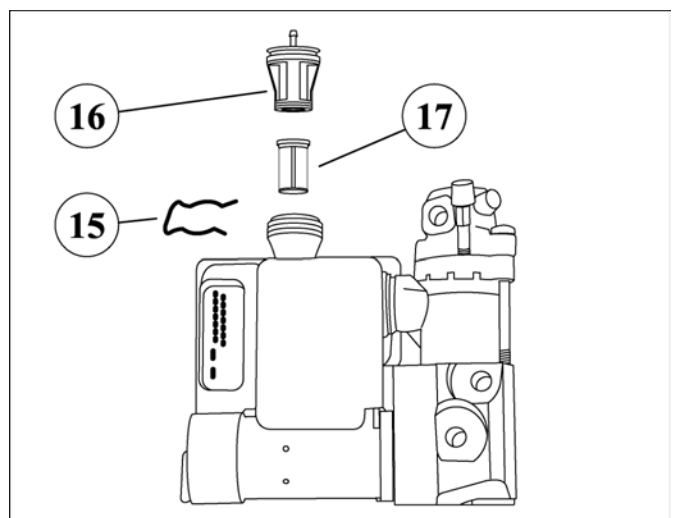

## WORKING ON THE ABS/PBS SYSTEM

### *To refit the control unit*

- Fill the control unit reservoir with new brake fluid to within 10 mm of the top lip
- Fit the filter, cap and clip

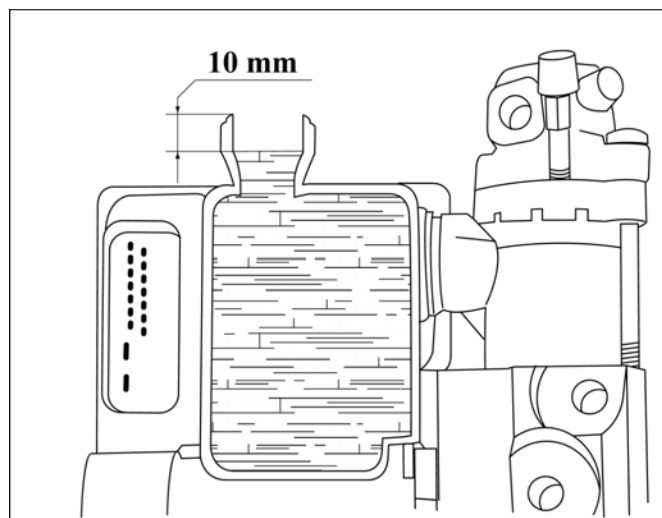

- Fit the control unit on its mounts but do not tighten it

**Note:** Fit new copper seals each time it is removed

- Fit the hydraulic hoses in the following order:
  - The hydraulic hose (1) from the left master cylinder
  - The hydraulic hose (2) to the rear brake caliper and fit it over hydraulic hose (1)
  - The hydraulic hose (3) from the right master cylinder
  - The hydraulic hose (4) to the front brake caliper

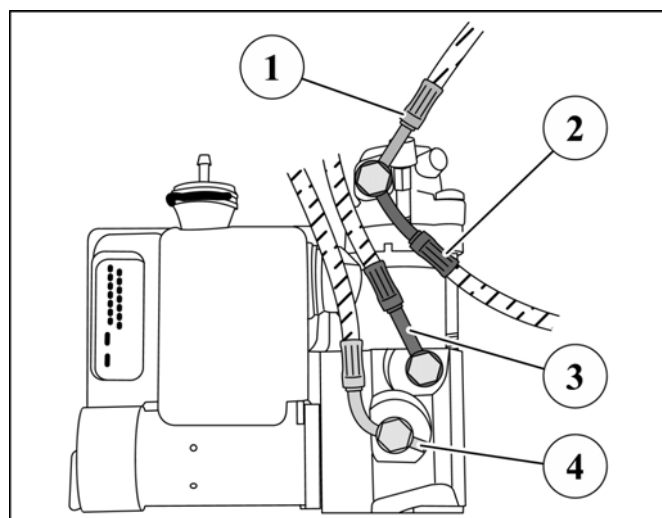

- Connect the control unit (5)
- Connect the feed pipe (6)
- Remove the feed hose clamp
- Release the control unit from its mounts so that it is as vertical as possible
- Bleed the hydraulic system using the correct method

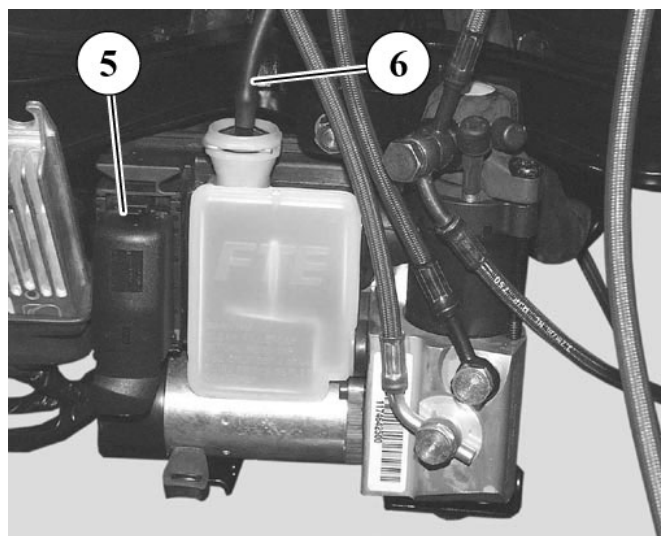



## WORKING ON THE ABS/PBS SYSTEM

### ABS/PBS SYSTEM BLEED METHOD

*Bleeding the front and rear circuits after changing the control unit*

- Fill the control unit reservoir with brake fluid before fitting to the machine
- Fit the control unit into its mounts without securing it
- Connect the hydraulic hoses to the control unit
- Remove the control unit from its mounts so that it is as vertical as possible

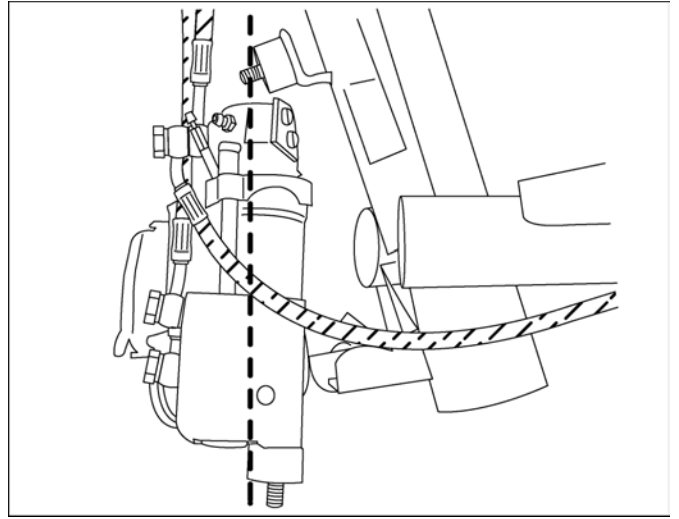

### **Rear brake circuit (main brake)**

- 1) Protect any plastics which may be exposed to brake fluid splashes
- Remove the left master cylinder cover
  - Position the handlebar in order to create a high point on the master cylinder to enable the bubbles in the circuit to rise more easily
  - Check the brake fluid level in the master cylinder and top up if necessary.

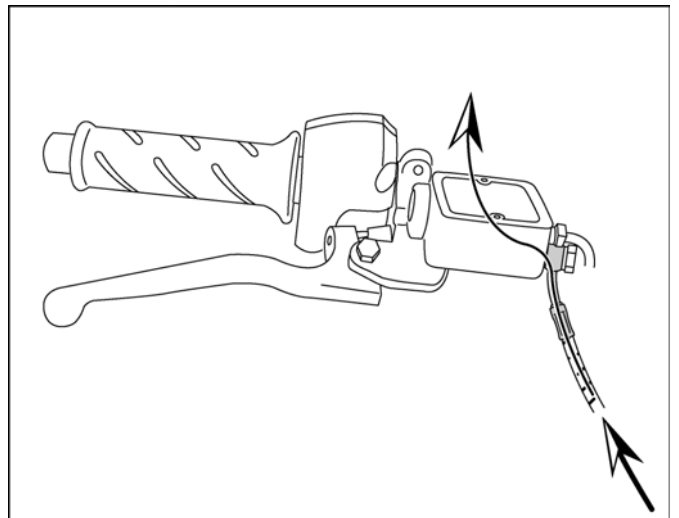

**Note:** It is essential to avoid being under the master cylinder during bleeding to avoid brake fluid splashes

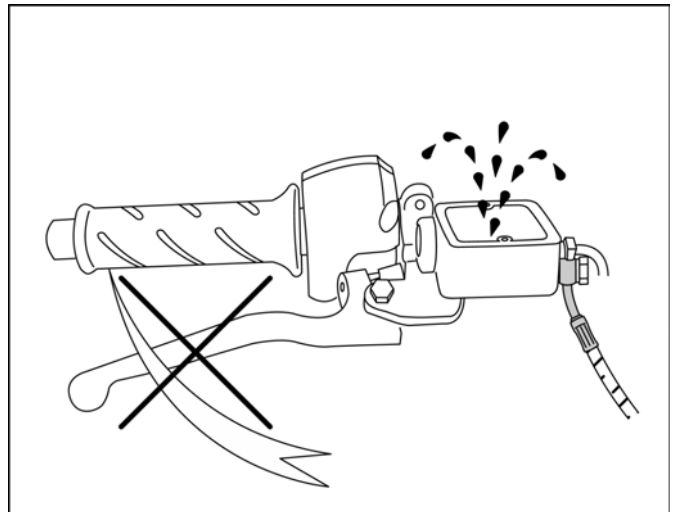

## WORKING ON THE ABS/PBS SYSTEM

2) Operate the right brake lever **evenly and smoothly** several times **very slowly** with a maximum movement of 2 cm from its rest position until no more bubbles can be seen coming up through the master cylinder reservoir.

3) Remove the bleed screw cap from the control unit integral circuit

- Connect the control unit bleed screw (1) to a recipient containing brake fluid using a transparent pipe. The recipient must be kept higher than the control unit to facilitate checking that the air bubbles are being expelled.
- Open the bleed screw half a turn

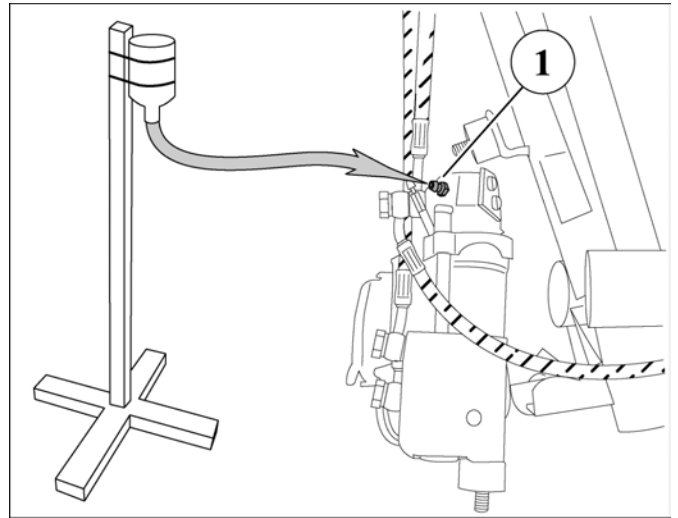

- Operate the left brake lever **evenly and smoothly** whilst topping up the fluid in the master cylinder
- Stop when there are no more bubbles coming from the control unit
- Close the bleed screw
- Re-fit the bleed screw cap

4) Remove the rear caliper bleed screw cap

- Connect the bleed screw to a recipient containing brake fluid using a transparent pipe. The recipient must be kept higher than the brake caliper to facilitate checking that the air bubbles are being expelled.
- Open the caliper bleed screw half a turn

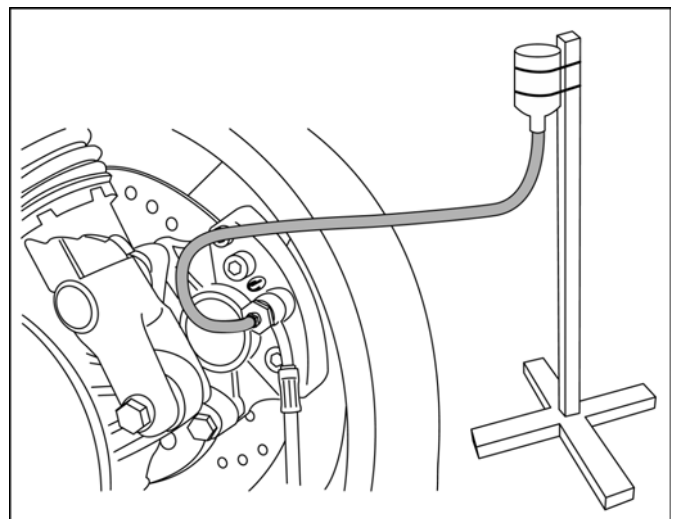

- Operate the brake lever **evenly and smoothly** whilst topping up the fluid in the master cylinder
- Stop when there are no more bubbles coming from the caliper
- Close the bleed screw
- Disconnect the pipe connecting it to the master cylinder
- Check the lever is firm

**Note:** If the lever does not feel sufficiently firm, repeat the operation as from paragraph 2

- Re-fit the bleed screw cap
- Check the brake fluid level in the master cylinder, top up if necessary and fit the cover

## WORKING ON THE ABS/PBS SYSTEM

### Front brake circuit (emergency brake)

1) Protect any plastics which may be exposed to brake fluid splashes

- Remove the hook or tie-wrap to release the lever
- Remove the right master cylinder cover
- Position the handlebar in order to create a high point on the master cylinder to enable the bubbles in the circuit to rise more easily
- Check the brake fluid level in the master cylinder and top up if necessary.

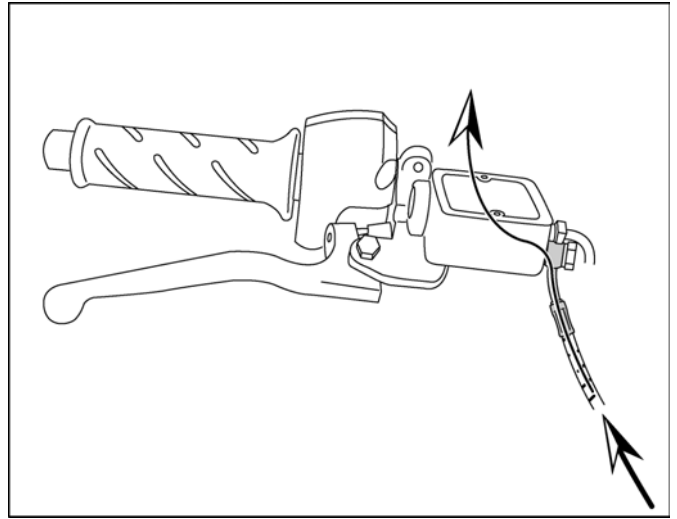

**Note:** It is essential to avoid being under the master cylinder during bleeding to avoid brake fluid splashes

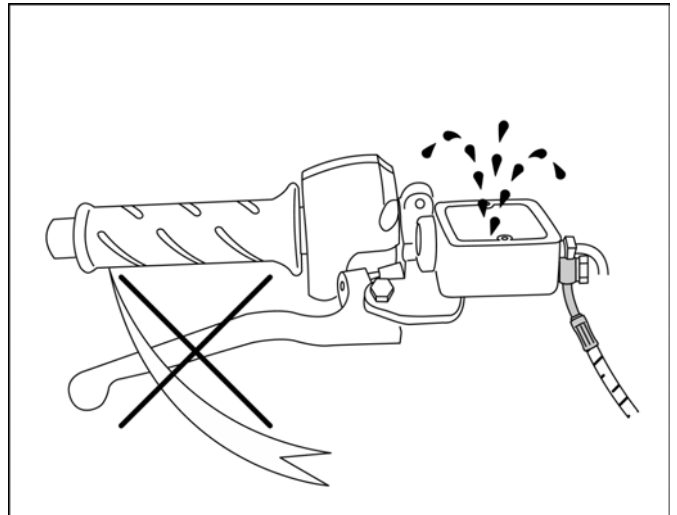

2) Operate the right brake lever **evenly and smoothly** several times **very slowly** with a maximum movement of 2 cm from its rest position until no more bubbles can be seen coming up through the master cylinder reservoir.

3) Remove the bleed screw cap from the control unit front circuit

- Connect the control unit bleed screw (2) to a recipient containing brake fluid using a transparent pipe. The recipient must be kept higher than the control unit to facilitate checking that the air bubbles are being expelled.
- Open the bleed screw half a turn

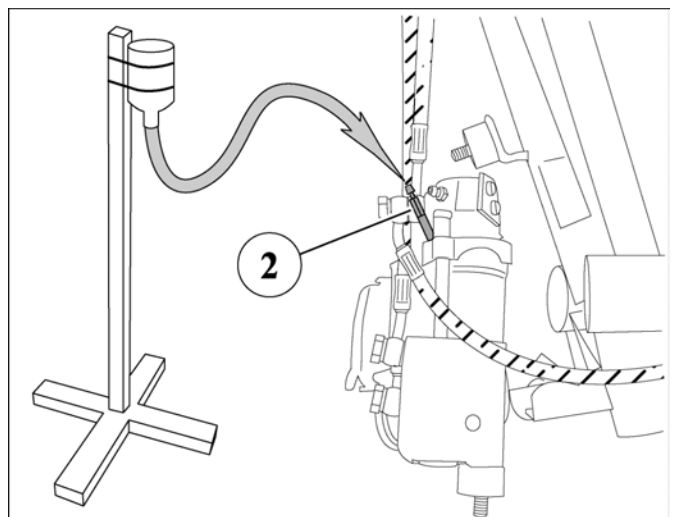

## WORKING ON THE ABS/PBS SYSTEM

- Operate the right brake lever **evenly and smoothly** whilst topping up the fluid in the master cylinder
- Stop when there are no more bubbles coming from the control unit
- Close the bleed screw
- Re-fit the bleed screw cap

- 4) Remove the front caliper bleed screw cap
- Connect the bleed screw to a recipient containing brake fluid using a transparent pipe. The recipient must be kept higher than the brake caliper to facilitate checking that the air bubbles are being expelled.
  - Open the caliper bleed screw half a turn

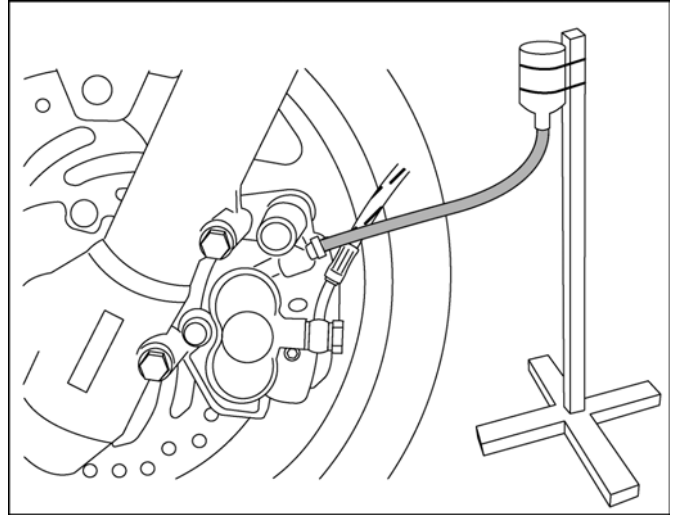

- Operate the brake lever **evenly and smoothly** whilst topping up the fluid in the master cylinder
- Stop when there are no more bubbles coming from the caliper
- Close the bleed screw
- Disconnect the pipe connecting it to the master cylinder
- Operate the pump using the diagnostic tool
- Check the lever is firm

**Note:** If the lever does not feel sufficiently firm, repeat the operation as from paragraph 2.

- Re-fit the bleed screw cap
- Check the brake fluid level in the master cylinder, top up if necessary and fit the cover

**Important:** The brake fluid level in the master cylinders in the horizontal position must always be above the sight gauge level.

## WORKING ON THE ABS/PBS SYSTEM

*Bleeding the circuit after removing a front or rear caliper, a front or rear lower hydraulic hose*

### Operation 1

- Remove the cover from the master cylinder to be bled
- Protect any plastics which may be exposed to brake fluid splashes
- Remove the caliper bleed screw cap

**Note:** If the integral circuit is to be bled (left lever), the right lever must be immobilised with a hook or cable tie (as described in the note on page 30).

- Connect the bleed screw to a recipient containing brake fluid using a transparent pipe. The recipient must be kept higher than the brake caliper to facilitate checking that the air bubbles are being expelled.

- Open the caliper bleed screw half a turn

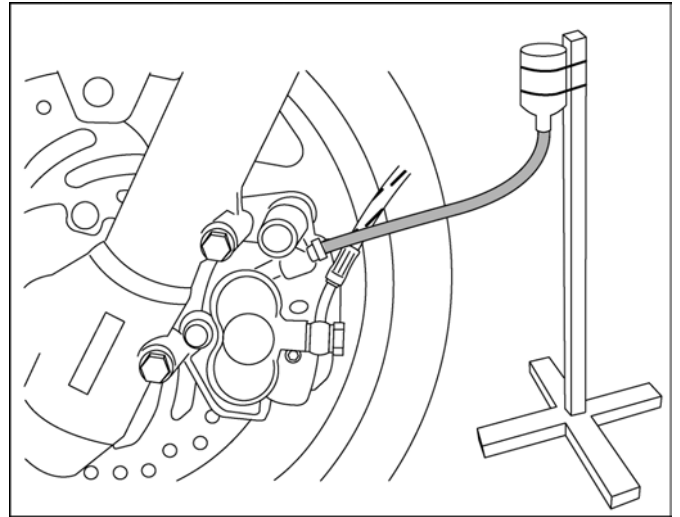

- Position the handlebar in order to set the master cylinder horizontal

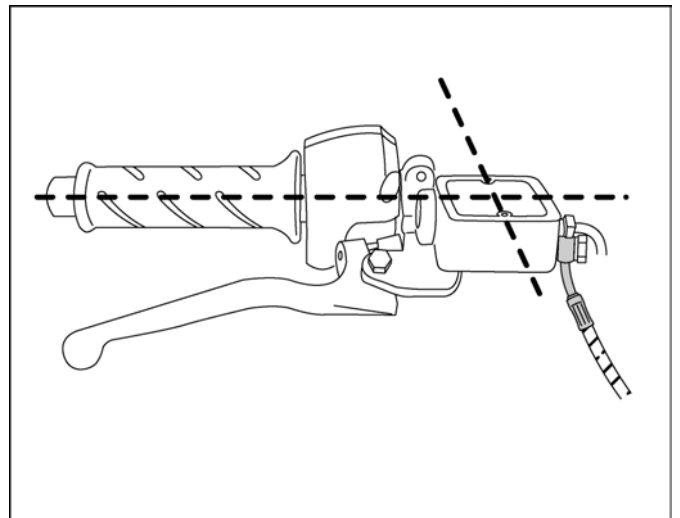

**Important:** It is essential to avoid being under the master cylinder during bleeding to avoid brake fluid splashes

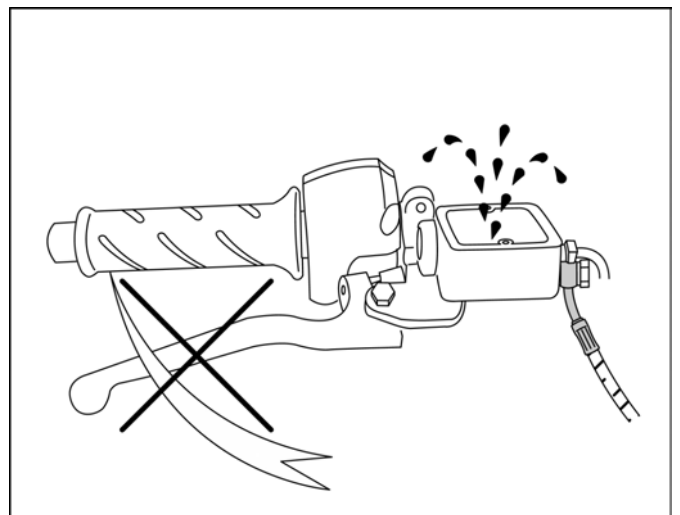

## WORKING ON THE ABS/PBS SYSTEM

- Operate the brake lever **evenly and smoothly** whilst topping up the fluid in the master cylinder
- Stop when there are no more bubbles coming from the caliper bleed screw
- Close the bleed screw
- Disconnect the pipe connecting it to the recipient
- Check the lever is firm without operating the lever violently to prevent brake fluid splashes

**Note:** On the left lever, if the lever does not feel sufficiently firm, carry out **operation 2**

On the right lever, carry out **operation 2** and operate the pump using the diagnostic tool to assess lever firmness

### Operation 2

The following operation must be carried out scrupulously, and consists in removing the air bubbles from the circuit through the relevant master cylinder, in order to guarantee correct operation of the brake circuits

- Position the handlebar in order to create a high point on the master cylinder to enable the bubbles in the circuit to rise more easily

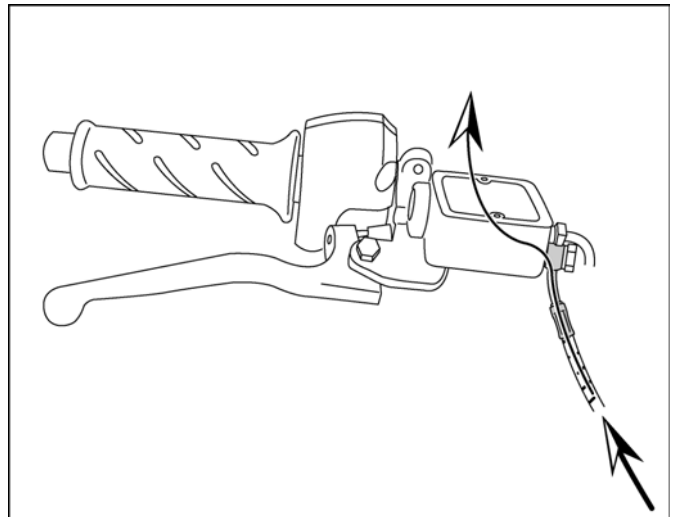

**Essential precautions:** 1) pumping with the brake lever must be carried out slowly.  
2) the lever must not come into contact with the handlebar.

- Protect any plastics which may be exposed to brake fluid splashes
- Operate the brake lever **slowly** with a maximum movement of 2 cm from its rest position until no more bubbles can be seen coming up through the master cylinder reservoir.
- Check the brake fluid level in the master cylinder and top up if necessary.
  - Refit the master cylinder cover

**Important:** The brake fluid level in the master cylinders in the horizontal position must always be above the sight gauge level

- Re-fit the bleed screw cap

This operation can only be successful if it is **not hurried**

- Using the diagnostic tool operate the pump to assess lever firmness

**Note:** If the lever does not feel sufficiently firm, repeat the operation as from operation 1

## WORKING ON THE ABS/PBS SYSTEM

*Bleeding the circuit after removing the front master cylinder or the upper front hydraulic hose (right side)*

The following operation must be carried out scrupulously, and consists in removing the air bubbles from the circuit through the relevant master cylinder, in order to guarantee correct operation of the brake circuits

- Protect any plastics which may be exposed to brake fluid splashes

- Remove the right master cylinder cover
- Fill the right master cylinder half full with brake fluid
- Position the handlebar in order to create a high point on the master cylinder to enable the bubbles in the circuit to rise more easily

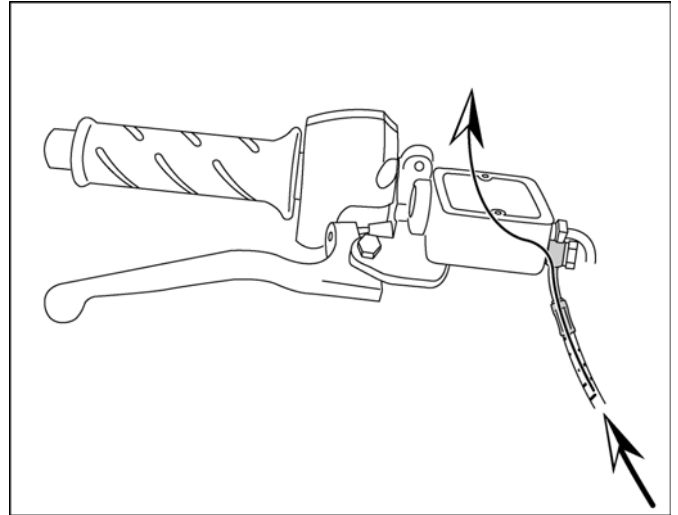

**Essential precautions:** 1) pumping with the brake lever must be carried out slowly.  
2) the lever must not come into contact with the handlebar.

Operate the brake lever **slowly** with a maximum movement of 2 cm from its rest position until no more bubbles can be seen coming up through the master cylinder reservoir.

This operation can only be successful if it is **not hurried**.

- Remove the bleed screw cap from the control unit front circuit

- Connect the bleed screw (2) to a recipient containing brake fluid using a transparent pipe. The recipient must be kept higher than the control unit to facilitate checking that the air bubbles are being expelled.
- Open the bleed screw half a turn

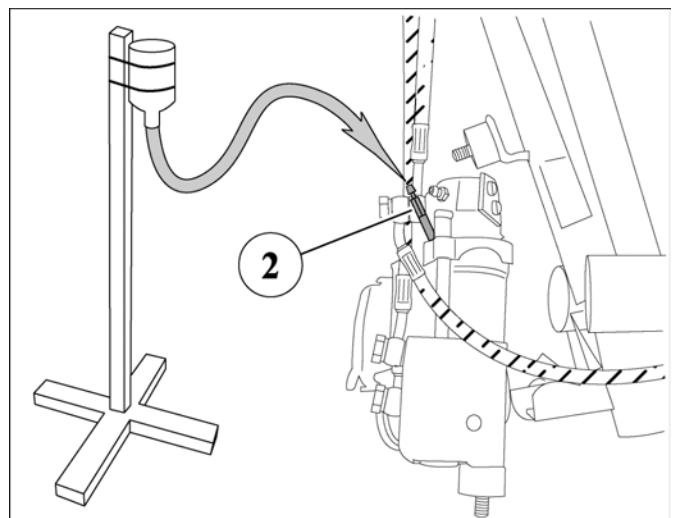

## WORKING ON THE ABS/PBS SYSTEM

**Important:** It is essential to avoid being under the master cylinder during bleeding to avoid brake fluid splashes

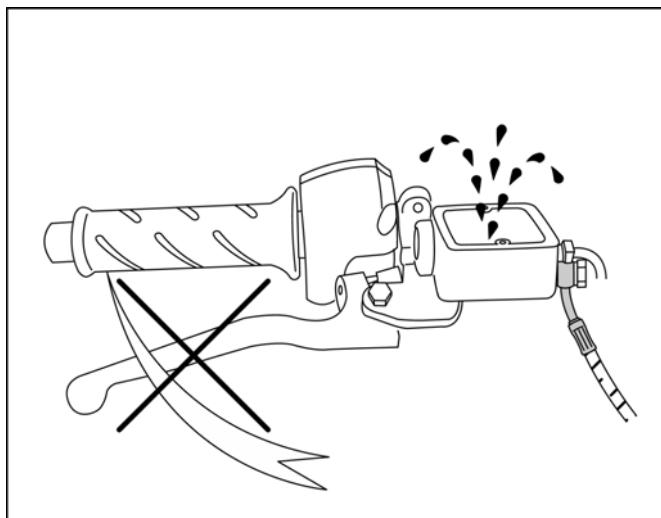

- Operate the brake lever **evenly and smoothly** whilst topping up the fluid in the master cylinder
- Stop when there are no more bubbles coming from the control unit bleed screw
- Close the bleed screw
- Disconnect the pipe connecting it to the recipient
- Using the diagnostic tool operate the pump to assess lever firmness

**Note:** If the lever does not feel sufficiently hard, bleed the power braking circuit.

- Operate the brake lever again slowly to check there are no more bubbles in the circuit
- Check the brake fluid level in the master cylinder, top up if necessary and fit the cover

**Important:** The brake fluid level in the master cylinders in the horizontal position must always be above the sight gauge level.

- Re-fit the bleed screw cap

**Note:** If the lever does not feel sufficiently firm, repeat the control unit bleed operation.



## WORKING ON THE ABS/PBS SYSTEM

Bleeding the circuit after removing the rear master cylinder or the upper front hydraulic hose (left side integral braking)

The following operation must be carried out scrupulously, and consists in removing the air bubbles from the circuit through the relevant master cylinder, in order to guarantee correct operation of the brake circuits

- Protect any plastics which may be exposed to brake fluid splashes

- Fill the left master cylinder half full with brake fluid
- Position the handlebar in order to create a high point on the master cylinder to enable the bubbles in the circuit to rise more easily

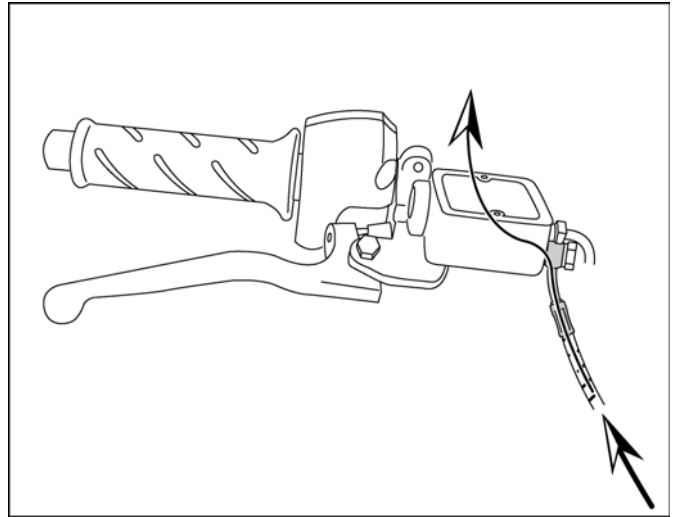

**Essential precautions:** 1) pumping with the brake lever must be carried out slowly.  
2) the lever must not come into contact with the handlebar.

Operate the brake lever **slowly** with a maximum movement of 2 cm from its rest position until no more bubbles can be seen coming up through the master cylinder reservoir.

This operation can only be successful if it is **not hurried**.

- Remove the rear caliper bleed screw cap
- Connect the bleed screw to a recipient containing brake fluid using a transparent pipe. The recipient must be kept higher than the brake caliper to facilitate checking that the air bubbles are being expelled.

- Open the caliper bleed screw half a turn

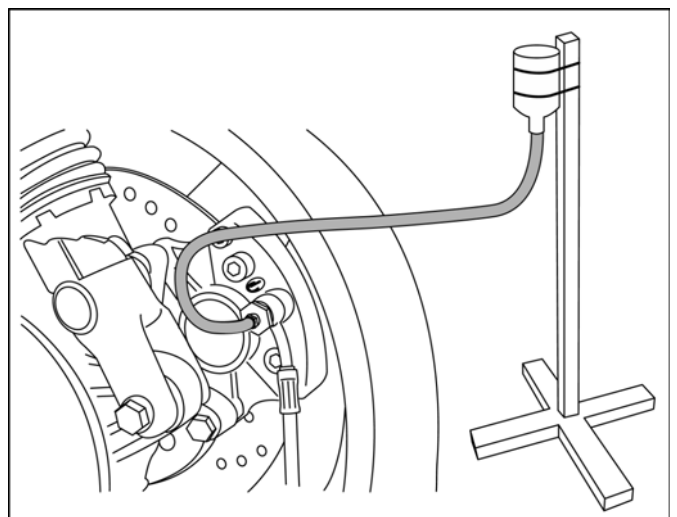

## WORKING ON THE ABS/PBS SYSTEM

**Important:** It is essential to avoid being under the master cylinder during bleeding to avoid brake fluid splashes

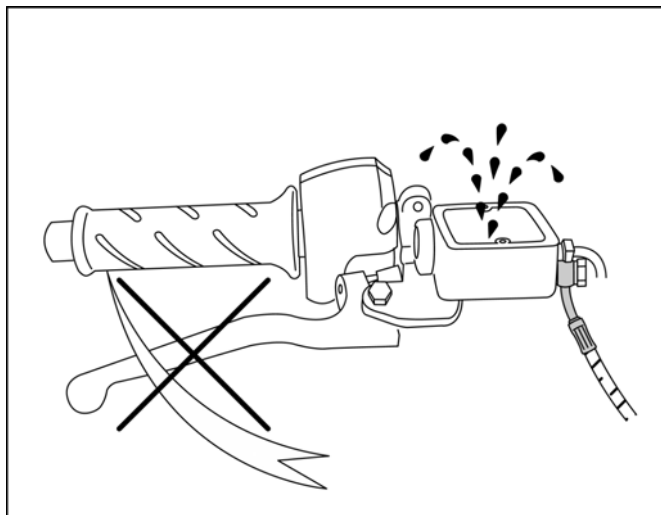

- Operate the brake lever **evenly and smoothly** whilst topping up the fluid in the master cylinder
- Stop when there are no more bubbles coming from the caliper bleed screw
- Close the bleed screw
- Disconnect the pipe connecting it to the recipient
- Check the lever is firm without operating the lever violently to prevent brake fluid splashes

**Note:** If the lever does not feel sufficiently firm, repeat the circuit bleed operation.

- Operate the brake lever again slowly to check there are no more bubbles in the circuit
- Check the brake fluid level in the master cylinder, top up if necessary and fit the cover
- Re-fit the bleed screw cap

## WORKING ON THE ABS/PBS SYSTEM

### Bleeding the power braking circuit

**Note:** Bleeding the power braking circuit is only of use in case of difficulty in obtaining sufficient firmness on the left lever

Before working on the power braking system you must ensure that the battery is fully charged, as excessive voltage drop will immediately cut off the power assistance pump

- Remove the right master cylinder cover

- Position the handlebar in order to set the master cylinder horizontal
- Check the brake fluid level in the master cylinder and top up if necessary.

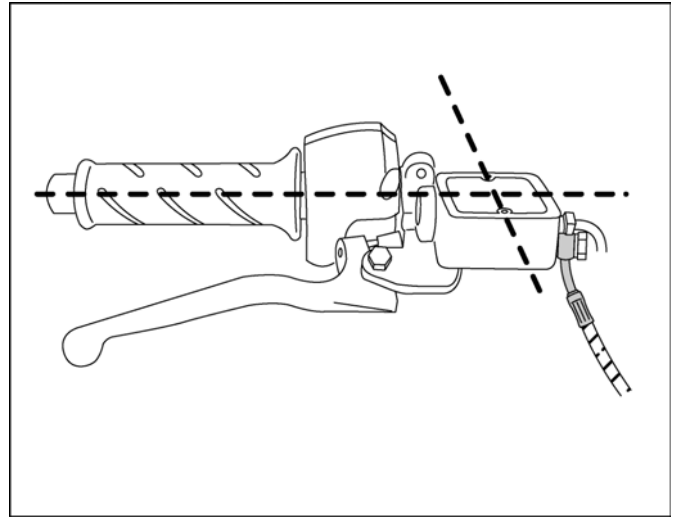

- Remove the front caliper bleed screw cap
- Connect a transparent pipe containing brake fluid from the front caliper bleed screw to the right master cylinder reservoir

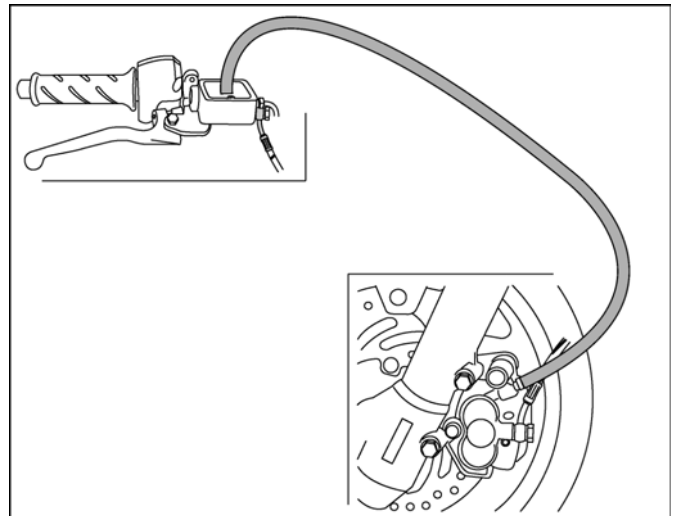

- Using the diagnostic tool, operate the control unit pump and exert a small pressure on the right lever
- Open the caliper bleed screw half a turn
- Maintain the pressure on the lever so that the pump continues to operate until the fluid circulates between the front caliper and the right master cylinder reservoir

**Note:** As a preventive measure, the pump should not be operated for more than 2 minutes continuously.

## WORKING ON THE ABS/PBS SYSTEM

- Ensure that the fluid level in the master cylinder does not drop below the pipe connecting with the control unit reservoir
- Stop the operation when there are no more bubbles in the transparent pipe
- Close the bleed screw
- Turn off the ignition
- Disconnect the transparent pipe by clamping the other end to stop the fluid running out
- Check the brake fluid level in the master cylinder and top up if necessary.

**Important:** The brake fluid level in the master cylinders in the horizontal position must always be above the sight gauge level.

- **Check the brake fluid level in the control unit reservoir and top up if necessary.**
- Refit the master cylinder cover
- Check the levers are firm
- Using the diagnostic tool, operate the control unit pump and exert a high pressure on each of the levers to ensure they are operating correctly



# HAZARD WARNING LIGHTS

## HAZARD WARNING LIGHTS

*Functioning principle diagram*

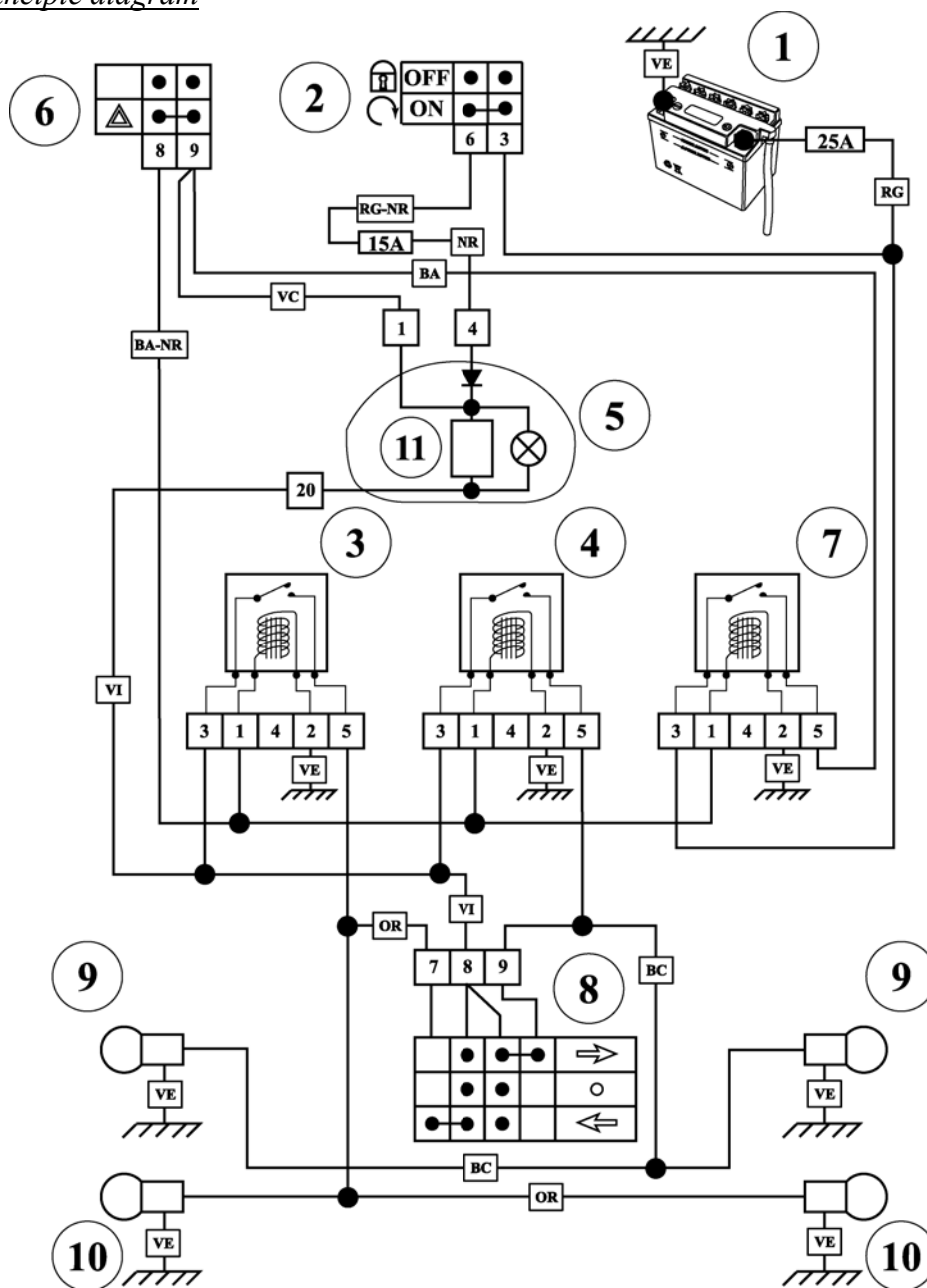

1. Battery
2. Ignition switch
3. LH direction indicators relay
4. RH direction indicators relay
5. Instrument panel
6. Hazard warning lights switch
7. Hazard warning lights relay
8. Direction indicator switch
9. RH direction indicators
10. LH direction indicators
11. Direction indicator unit

BA	White
BA/NR	White/Black
BC	Light blue
NR	Black
OR	Orange
RG	Red
RG/NR	Red/Black
VC	Light Green
VE	Green
VI	Mauve

## HAZARD WARNING LIGHTS

### Operation

#### 1. Ignition to ON

- The ignition switch (2) powers over pin (4) on the instrument panel (5):
  - The direction indicator unit (11)
  - Terminal (9) on the hazard warning lights switch (6)
- The hazard warning lights switch (6) when to "ON" operates relays (3, 4 and 7)
  - Relay (3) powers the LH direction indicators (10)
  - Relay (4) powers the RH direction indicators (9)
  - Relay (7) powers the hazard warning lights switch (6) with the + battery

#### 2. Ignition to OFF

- The power supply to the direction indicator unit (11) is no longer through the ignition switch (2) but through relay (7) using the + battery.
- Functioning of the hazard warning lights is identical with the previous chapter (ignition to ON).

**Note:** If the hazard warning lights switch is moved the relay (7) control circuit power supply is cut off, and the hazard warning lights function de-activated.

The ignition must be turned on again to activate the hazard warning lights function.

## LOCATION OF COMPONENTS

### LOCATION OF COMPONENTS

*Elystar 50 cc*

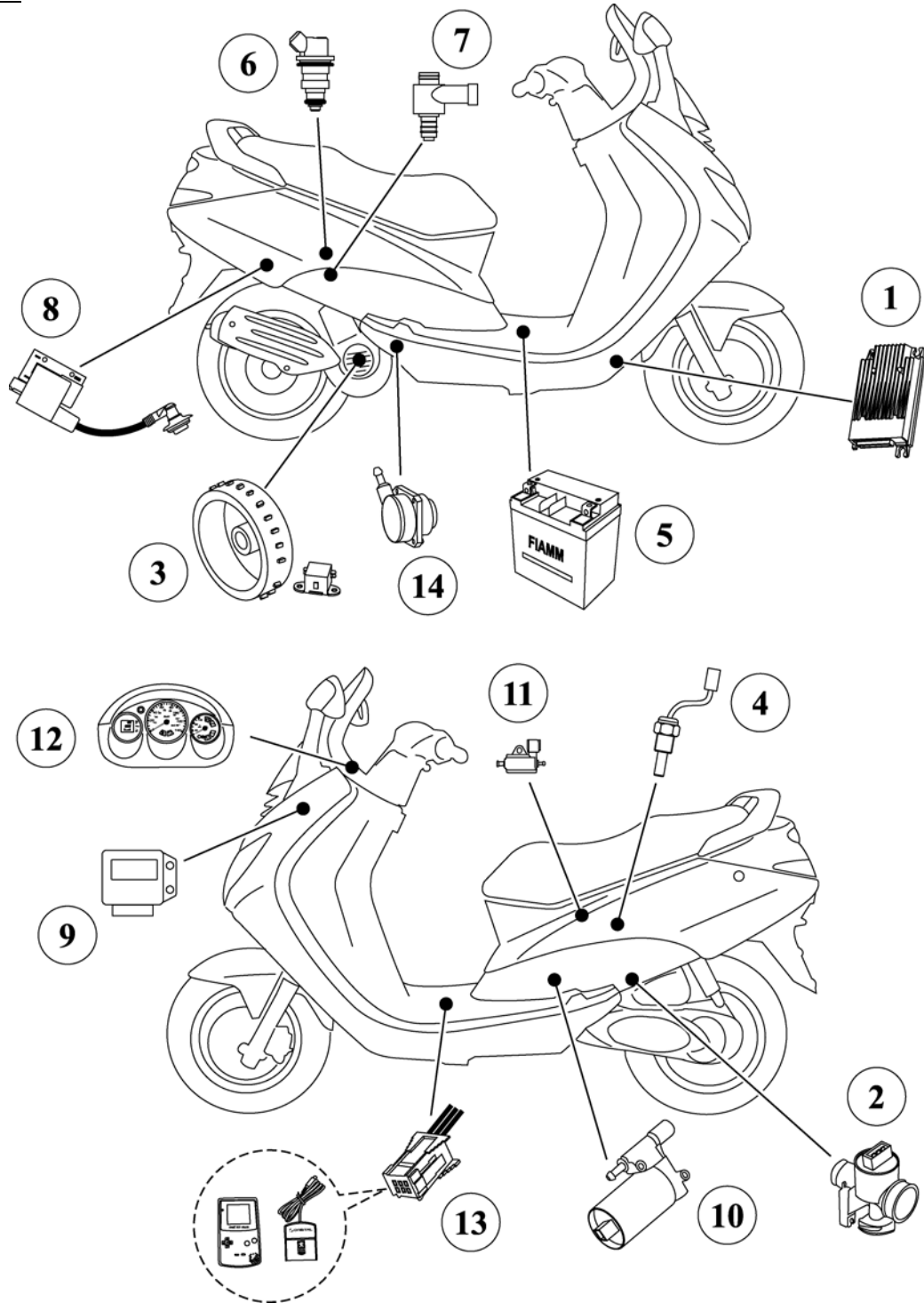

- |                                     |                       |
|-------------------------------------|-----------------------|
| 1. Injection ECU                    | 8. Ignition coil      |
| 2. Throttle unit                    | 9. Immobiliser module |
| 3. Engine position and speed sensor | 10. Petrol pump       |
| 4. Engine temperature sensor        | 11. Oil pump          |
| 5. Battery                          | 12. Diagnostic lamp   |
| 6. Petrol injector                  | 13. Diagnostic plug   |
| 7. Air injector                     | 14. Compressor        |

## LOCATION OF COMPONENTS

### Elystar 125-150 cc

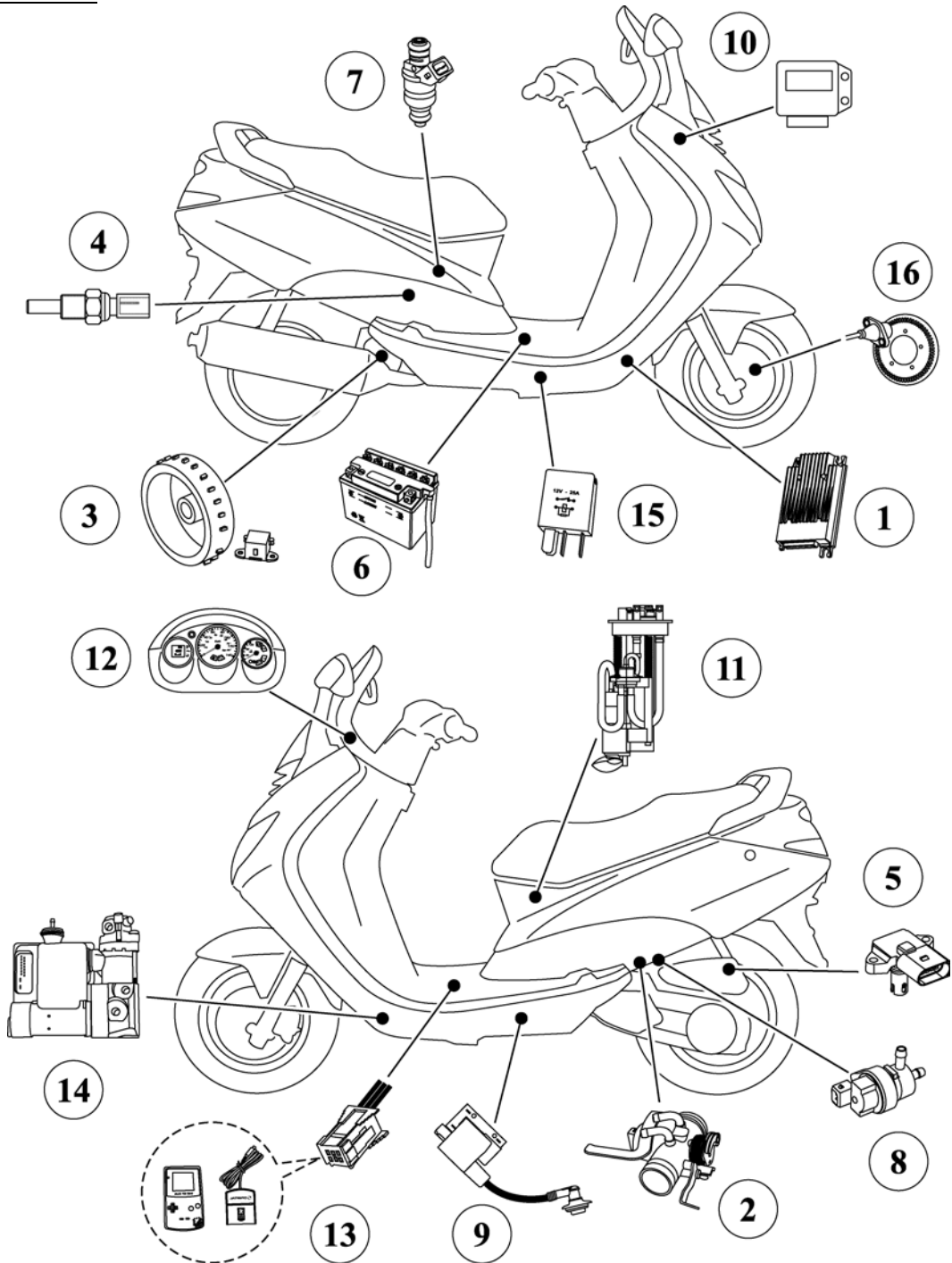

- |  |  |
|--|--|
| <ul style="list-style-type: none"> <li>1. Injection ECU</li> <li>2. Throttle unit</li> <li>3. Engine position and speed sensor</li> <li>4. Engine temperature sensor</li> <li>5. Atmospheric pressure and air temperature sensor</li> <li>6. Battery</li> <li>7. Petrol injector</li> <li>8. Idle valve</li> <li>9. Ignition coil</li> </ul> | <ul style="list-style-type: none"> <li>10. Immobiliser module</li> <li>11. Petrol pump</li> <li>12. Diagnostic lamp</li> <li>13. Diagnostic plug</li> <li>14. Control unit</li> <li>15. Petrol pump, ABS/PBS, direction indicators and hazard warning lights relays</li> <li>16. Speed sensor and pulse wheel</li> </ul> |
|--|--|





**PEUGEOT**  
*Motocycles*

RECOMMENDS



 **UTAC**  
CERTIFICATION  
SYSTEMES QUALITE  
ISO 9001  
Certificat n° SQ/766

**REF: 756445**

With a constant concern for improvement Peugeot Motocycles reserves the right to delete, modify, or add any quoted reference  
DC/PS/ATR printed in E.U. 06/2002 (photos non-contractual)

