



Sales division
Technical network leadership

WORKSHOP MANUAL



SPEEDFIGHT 3 4T

TABLE OF CONTENTS









TABLE OF CONTENTS.....	1
PRODUCTS DANGER SYMBOLS USED.....	4
CHARACTERISTICS.....	6
Engine.....	6
Capacities	6
Chassis	7
Dimensions and weight.....	7
Tyres	7
Brakes.....	8
SERVICE SCHEDULE AND COMMISSIONING.....	9
To be checked at each service.....	9
Service operations.	10
Time required for maintenance	10
Battery preparation (Except battery without maintenance)*	11
Installing the battery vapour vent hose.	11
New machine preparation	11
SPECIAL IMPORTANT POINTS.....	12
Oil and fuel.....	12
TIGHTENING TORQUES	13
Engine part	13
Body panels	13
Cycle part.....	14
Standard	14
SPECIAL TOOLS	15
STANDARD TOOLS.....	15
LOCATION OF COMPONENTS.....	16
BODY PANELS	17
Location of body components	17
Body component sequence of disassembly.....	18
Removal of the storage compartment.....	19
Removal of the rear cover assembly and mudflap	20
Removal of handlebar fairing	21
Removal of the front top shield panel.....	22
Removal of the rear shield panel	22







Removal of front lower shield panels	23
Removal of the footboard	24
Removal of the under body panel	24
SERVICE OPERATIONS.....	25
Changing the engine oil	25
Draining the relay box	26
Removal of the spark plug	27
Replacing the air filter.	27
Transmission	28
Checking the drive belt	30
Checking the clutch linings	31
Replacing the clutch lining assembly	31
Installing the valve clearance	32
Idle setting.....	33
Brake inspection	34
Replacing the brake pads	34
Checking the brake fluid level	35
Rear brake linings	36
Disassembly.....	36
Reassembly	37
Removal of the fuel filter	38
STEERING/FORK.....	39
Changing the front fork seals	39
Removal of the fork tubes	41
The fork and its components.....	42
Removal of the fork.....	43
Replacing the steering head cups.....	44
Installing the fork.....	45
Steering system tightening method.....	45
ELECTRICITY.....	47
Ignition principle schematic/Carburetor heater	47
Temperature control unit/Regulator/Starter motor relay/Ignition unit	48
Checking the carburetor heating circuit.....	48
Checking the ignition system	49
Fuel gauge	49

FUEL SYSTEM	50
Removal of the fuel pump	50
Removal of the carburettor.....	50
Removal of the throttle valve.....	50
Removal of the float, needle valve and jets.....	51
Removal of the mixture screw.....	52
Removal of the pick-up pump	53
Removal of the pick-up pump suction valve.....	53
Removal of the deceleration enrichment device	53
Removal of the carburetor heater	54
The carburettor and its components	54
POWER UNIT	55
Removal of the power unit	55

PRODUCTS DANGER SYMBOLS USED

Protection of individuals and of the environment.

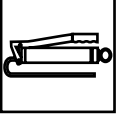
	Möbius band	Recyclable.	Means that the product or the package can be recycled. However, this does not guarantee that the product will be recycled.
	Irritant	The product can irritate the skin, eyes and respiratory organs.	Avoid contact with skin and clothes. Wear gloves, safety goggles and appropriate clothes such as a cotton overall. Do not breath fumes. If in contact, wash thoroughly with water.
	Flammable	The product is flammable.	Keep it away from flames or any heat source (barbecue, radiator, heater, etc.). Do not leave the product in the sun.
	Corrosive	The product can damage living tissues or other surfaces.	Avoid contact with skin and clothes. Wear gloves, safety goggles and appropriate clothes such as a cotton overall. Do not breath fumes.
	Explosive	The product can explode under certain circumstances (flame, heat, impact, friction).	Avoid impacts, friction, sparks and heat.
	Hazardous to the environment	The product affects fauna and flora. Do not dump it in dustbins, sinks or in the environment.	The ideal solution is to bring this product to your nearest household waste recycling centre.
	Toxic	The product can seriously affect health if it is inhaled, ingested or in contact with skin.	Avoid direct contact with the body, even by inhalation. If you feel unwell, seek medical advice immediately.
	Do not throw away into a garbage can	One of the product's component is toxic and can be hazardous to environment. i.e.: Used batteries.	This symbol informs the consumer that the used product shall not be thrown away into a garbage can, but shall be brought back to the merchant or dropped at a specific collection point.
	Compulsory gloves	Operation that can be dangerous for people.	People's safety can be seriously affected if the recommendations are not fully respected.

	People's safety	Operation that can be dangerous for people.	People's safety can be seriously affected if the recommendations are not fully respected.
	Important	Operation that can be hazardous to the vehicle.	Indicate the specific procedures that shall be followed in order not to damage the vehicle.
	Good operating condition of the vehicle	The operation must be carried out in strict compliance with the documents.	Serious damage to the vehicle and in certain cases a cancellation of the warranty can be involved if the recommendations are not fully respected.
	Note	Operation that can be difficult.	Indicate a note which gives key information to make the procedure easier.
	Lubricate	Lubricate the parts to be assembled.	Indicate the specific procedures that shall be followed in order not to damage the vehicle.
	Grease	Grease the parts to be assembled.	Indicate the specific procedures that shall be followed in order not to damage the vehicle.
	Glue	Glue the parts to be assembled.	Indicate the specific procedures that shall be followed in order not to damage the vehicle.
	New part	Use a new part.	Indicate the specific procedures that shall be followed in order not to damage the vehicle.

CHARACTERISTICS

■ Engine

	Speedfight 3
Type	4-stroke single-cylinder Horizontal cylinder. 2 valves per cylinder with chain driven overhead camshaft
Cooling	By a circulation of forced air by means of a turbine on the flywheel magneto
Bore x stroke	37 x 46 mm
Cubic capacity	49.5 cc
Max. power output	2.8 kW at 8000 rpm
Max. torque rating	3.5 Nm at 6500 rpm
Compression	9.5 bars at 550 rpm
Fuel supply	Carburettor KEIHIN NCV
Lubrication	Pressurised wet sump lubrication Trochoid pump driven by a gear set from the crankshaft
Transmission	By 2 variable pulleys and V-type belt
Clutch	Centrifugal automatic
Exhaust	With catalytic system and pulsair valve
Standards	Euro 3
Starter motor	By kick starter or electric starter
Spark plug	NGK CR6HSA Electrode gap : 0.6 mm
Magneto flywheel	80 W

■ Capacities

Crankcase	0.7 L SAE 5W40 Minimum grade : API SL/SJ
Relay box	0.1 L SAE 80W90 Minimum grade : API GL4
Fuel tank	8 l 95 or 98 lead-free

■ Chassis

	Speedfight 3
Chassis	Steel tube
Front suspension	Upside down telescopic front fork Ø32 mm. Travel : 80 mm
Rear suspension	Combined spring and hydraulically-damped shock absorber Travel : 65 mm

■ Dimensions and weight

Overall length	1895 mm
Width at handlebar	700 mm
Height (without rear-view mirrors).	1120 mm
Wheelbase	1290 mm
Saddle height	810 mm
Unladen weight	100 kg

■ Tyres

Front wheel rim	13 inch aluminium alloy
Front tyre	130/60 - 13
Front tyre pressure	1.8 bars
Rear wheel rim	13 inch aluminium alloy
Rear tyre	130/60 - 13
Rear tyre pressure	2 bars

■ Brakes

	Speedfight 3
Front brake	Single disc type, hydraulic control
Disc diameter and thickness	215 mm - 3.5 mm
Rear brake	cable-controlled, single cam drum type
Brake drum diameter	110 mm
Brake lining thickness	4 mm

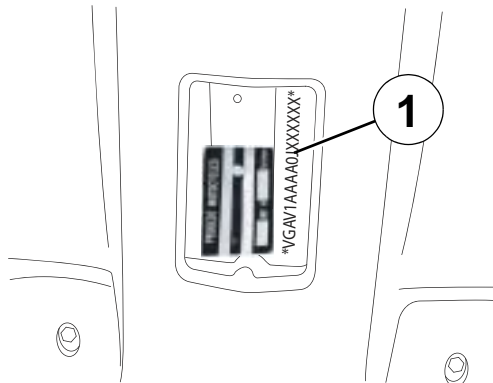
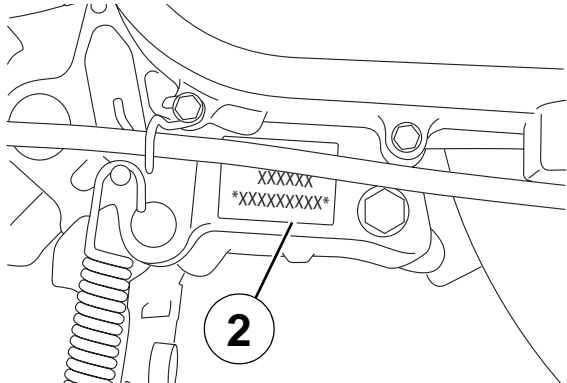
Chassis markings	Engine marking
 <p>(1) number and manufacturer's plate</p>	 <p>Engine number (2)</p>

SERVICE SCHEDULE AND COMMISSIONING

Heavy duty servicing applies to vehicles used under rugged operating conditions: door-to-door deliveries, intensive urban use (courier), short journeys with engine cold, dusty areas, ambient temperature over 30°C.

Normal servicing in km	500	2000	5000	10000	15000	20000
Extensive servicing in km	500	1000	2500	5000	7500	10000
Minimum servicing	1 month	6 months	12 months	24 months	36 months	48 months

■ **To be checked at each service.**

Steering column play.	V	V	V	V	V	V
Wheel bearing play.	C	C	C	C	C	C
Throttle cable play.	V	V	V	V	V	V
Operation of electrical equipment.	V	V	V	V	V	V
Condition of the front brake hydraulic control.	V	V	V	V	V	V
Brake fluid level.	V	V	V	V	V	V
Front brake pad wear.	C	C	C	C	C	C
Rear brake lining wear.	C	C	C	C	C	C
Condition of petrol pipes.	C	C	C	C	C	C
Tyre condition, pressure and wear.	C	C	C	C	C	C
Condition of the front suspension. Condition of the rear suspension.	V	V	V	V	V	V
Battery electrolyte level. Battery charge.	V	V	V	V	V	V
Engine oil level.	Every 1000 kms					
Headlight height adjustment.	V	V	V	V	V	V
Tightness of nuts and bolts.	V	V	V	V	V	V
Overall operation. Road test.	V	V	V	V	V	V

V: Check, clean, adjust.

R: Change.

G: Check, clean, lubricate.

N: Clean.

C: Inspect and change if necessary.

* Depending on equipment.

Normal servicing in km	500	2000	5000	10000	15000	20000
Extensive servicing in km	500	1000	2500	5000	7500	10000
Minimum servicing	1 month	6 months	12 months	24 months	36 months	48 months

■ **Service operations.**

Spark plug.	V		R	R	R	R
Air filter.				R		R
Intake silencer drain.			N	N	N	N
Drive pulley bearings and guides.			V	C	V	C
Transmission belt.				R		R
Driven pulley caged needle bearing.			G	G	G	G
Kick starter mechanism.				G		G
Valve clearances.		V	V	V	V	V
Setting the carburettor.				V		V
Joints (Central stand, Brake levers).			G	G	G	G
Petrol filter.						R
Engine oil (+ clean strainer).	R	R	R	R	R	R
Relay box oil.	R		R	R	R	R
Petrol pipe.	R Once every 5 years					
Brake fluid.	R Once every 2 years					

■ **Time required for maintenance**

Code	9100	9150	9300	9400	9500	9600
Servicing time in tenths of an hour. (0.5 h = 30 min)	1.2	2.1	3.3	3.9	3.3	4.2

V: Check, clean, adjust.

R: Change.

G: Check, clean, lubricate.

N: Clean.

C: Inspect and change if necessary.

* Depending on equipment.

■ Battery preparation (Except battery without maintenance)*

Remove the battery.

Remove the 6 filler caps and the vent plug.

Fill all the battery cells with electrolyte to the upper level shown on the battery " UPPER LEVEL ".

Electrolyte: (35% sulfuric acid = 1.28g/cm³). 0.5 litre can P/N 739733.

Leave the battery to stand for around half an hour.

Top up if necessary.

Charge the battery for at least 2 hours with a current of 0.4 A.

Refit the battery and connect the vapour vent pipe.

Connect the red wire lug to the battery's + terminal, and the green wire lug to the battery's - terminal.

Then, the battery level should be topped up if necessary, after fully charging, using distilled water only.

* Depending on equipment.

Installing the battery vapour vent hose.

- After being connected to the battery, the vapour vent hose must be routed through the 2 holders located in the rear splash guard.
- Cut the vent hose 1 cm after the second holder (1).

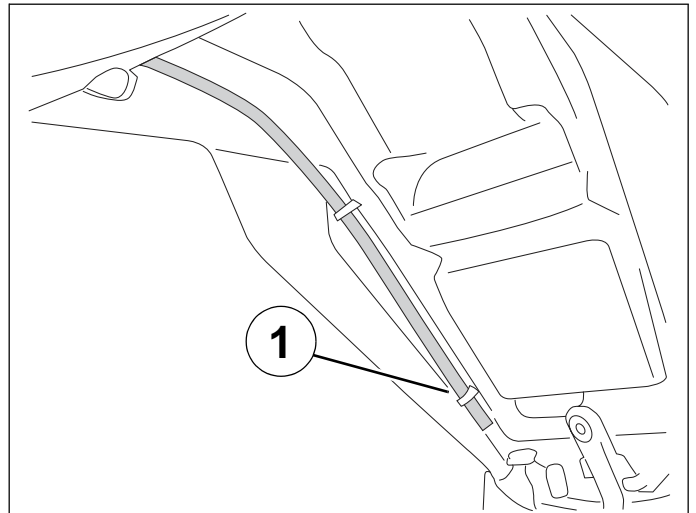

■ New machine preparation

Check the tightness of the carburettor float chamber drain screw.

Check the wheel nuts are tight.

Check nuts and bolts are tight.

Check brake adjustment and efficiency.

Check the tyre pressures cold.

Check operation of the lights, flashers, horn, and brake light.

Check the different warning lights work.

Carry out a road test.

SPECIAL IMPORTANT POINTS

■ Oil and fuel



This engine is designed to run on 95 or 98 unleaded fuel only.



**Fuel pipes must absolutely be changed if there are any signs of wear, cracks, etc.
The air pipe between the air pump and the exhaust is specific owing to its heat resistance properties.**

Should it be changed, replace it with a genuine pipe.

The clips are specific, they must always be changed each time they are removed and replaced with new genuine parts clips.



Petrol is highly inflammable, do not smoke in the working area and avoid proximity to flames or sparks.

Before carrying out any work, leave the engine to cool for at least 2 hours.

TIGHTENING TORQUES**■ Engine part**

Spark plug	12 Nm
Filler cap	20 Nm
Screen	15 Nm
Cylinder head	
Nut Ø6 mm	20 Nm
Screw Ø6 mm	12 Nm
Camshaft gear cover	10 Nm
Camshaft gear	20 Nm
Valve clearance covers	15 Nm
Automatic tensioner	10 Nm
Automatic tensioner plug	8 Nm
Chain tensioner	10 Nm
Inlet manifold	10 Nm
Crankcase	12 Nm
RH casing cover	12 Nm
Freewheel	90 Nm
Oil pump	10 Nm
Transmission cover	10 Nm
Relay box cover	22 Nm
Relay box drain plug	10 Nm
Starter motor	10 Nm
Rotor	55 Nm
Turbine	10 Nm
Stator	12 Nm
Engine speed sensor	12 Nm
Drive pulley	55 Nm
Driven pulley	55 Nm
Clutch plate and shoes	55 Nm

■ Body panels

Front mudguard	8 to 10 Nm
Handlebar cover	1 to 2 Nm
Front shield panels	1 to 2 Nm
Rear shield	4 to 8 Nm
Bottom panel	1 to 2 Nm
Floor panel	4 to 8 Nm
Saddle storage compartment	4 to 8 Nm
Rear panels	1 to 2 Nm
Grab handle	20 to 25 Nm

■ Cycle part

Front wheel spindle	65 Nm
Front wheel spindle flange	10 Nm
Rear wheel spindle nut	120 Nm
Linkrod to engine pivot	60 Nm
Linkrod to frame pivot	60 Nm
Shock absorber top mount	45 Nm
Shock absorber bottom mount	25 Nm
Exhaust to cylinder mounting nut	15 Nm
Exhaust to casing mounting bolt	30 Nm
Upper cone (in 2 operations)	40/17 Nm
Upper cone locknut	Hand tightened
Steering locknut	70 Nm
Front brake caliper	45 Nm
Front brake disc	30 Nm
Fork arm	25 Nm
Handle bar	40 Nm

■ Standard

Nut and bolt 5 mm diameter	5 Nm
Nut and bolt 6 mm diameter	10 Nm
Nut and bolt 8 mm diameter	22 Nm
Nut and bolt 10 mm diameter	35 Nm
Nut and bolt 12 mm diameter	55 Nm

SPECIAL TOOLS

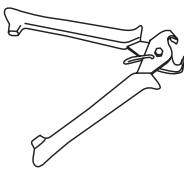
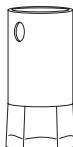
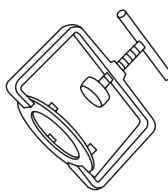
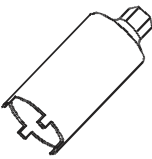
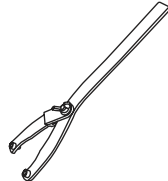
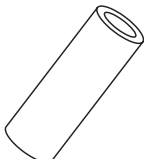
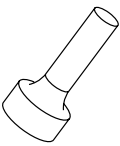
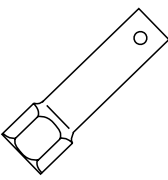
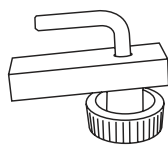
	Tool N°	Designation	Used with		Tool N°	Designation	Used with
	750539	Tie-wrap pliers			752361	39 mm pipe wrench	752127
	752127	Clutch compression tool	756725		757860	Steering tool	
	752237	Adjustable pin wrench			757990	Steering head cup push tool	
	753726	Steering head cup push tool			766062	Spark plug spanner	
	755996	Hose clamp					

■ STANDARD TOOLS

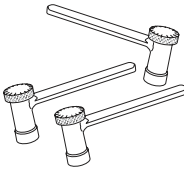
	Wrenches with interchangeable end fittings for valve clearance adjustment Type : Marolotest P/N 500140
---	---

LOCATION OF COMPONENTS

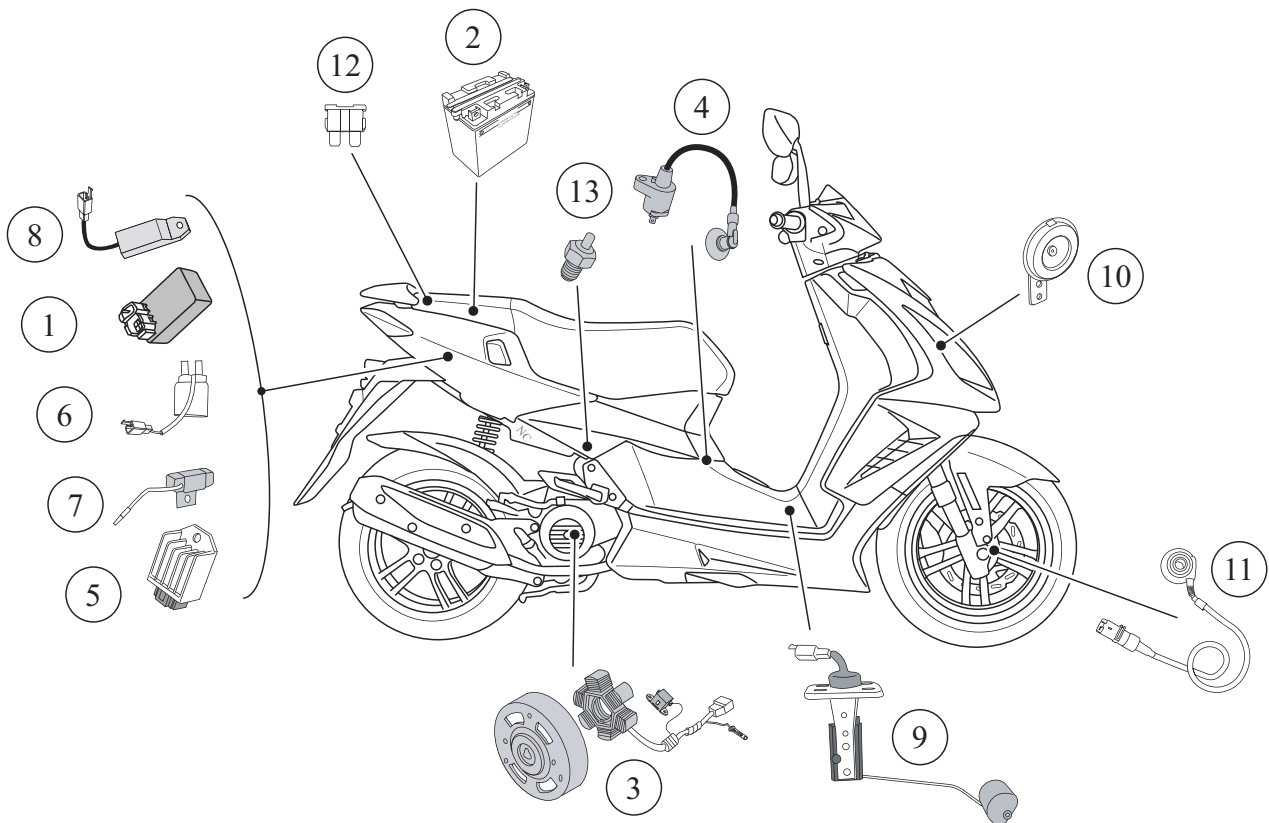

- | | |
|------------------------|---------------------------------|
| 1. CDI unit | 8. Temperature control unit |
| 2. Battery | 9. Fuel gauge |
| 3. Ignition sensor | 10. Horn |
| 4. HT coil | 11. Speed sensor |
| 5. Regulator | 12. Fuses |
| 6. Starter motor relay | 13. Resistor warming carburator |
| 7. Starter resistor | |

BODY PANELS

■ Location of body components

Description

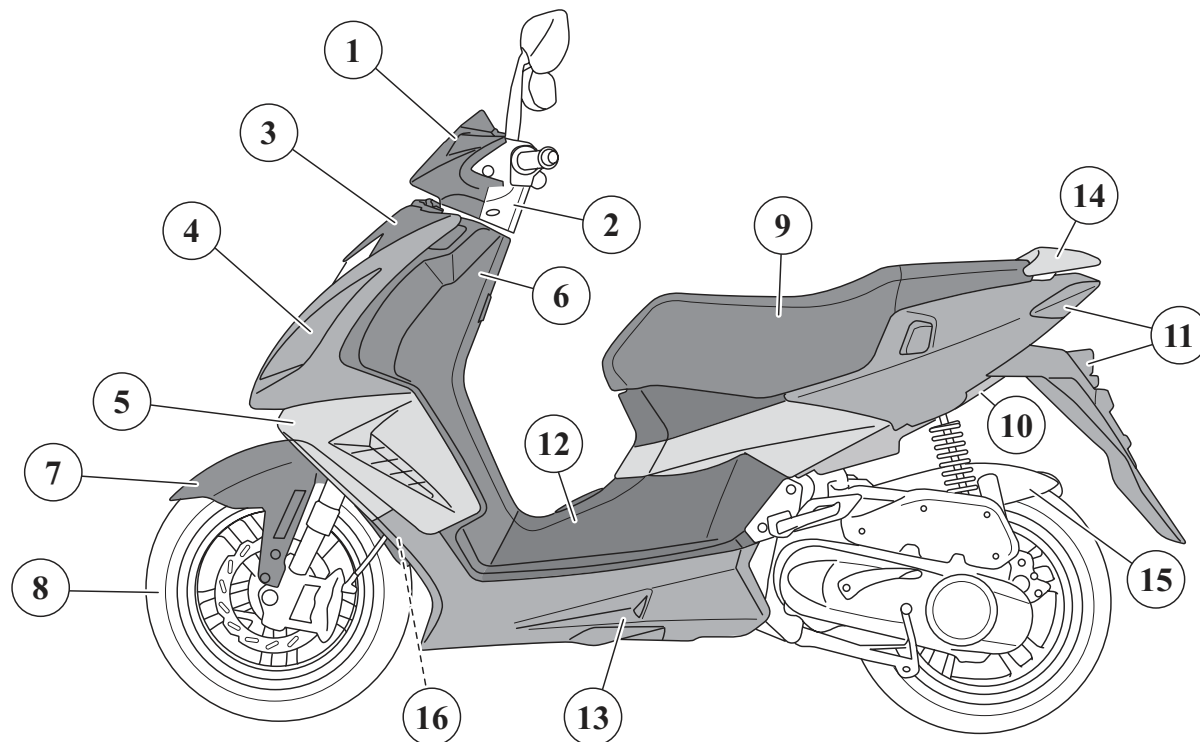

- | | |
|-----------------------------------|-------------------|
| 1. Handlebar front fairing | 10. Lower fairing |
| 2. Handlebar rear fairing | 11. Rear panels |
| 3. Front top cover panel | 12. Footboard |
| 4. Legshield top panel | 13. Bottom panel |
| 5. Front lower legshields | 14. Grab handle |
| 6. Rear shield | 15. Rear mudguard |
| 7. Front mudguard | 16. Mudguard |
| 8. Front wheel | |
| 9. Saddle and storage compartment | |

■ Body component sequence of disassembly

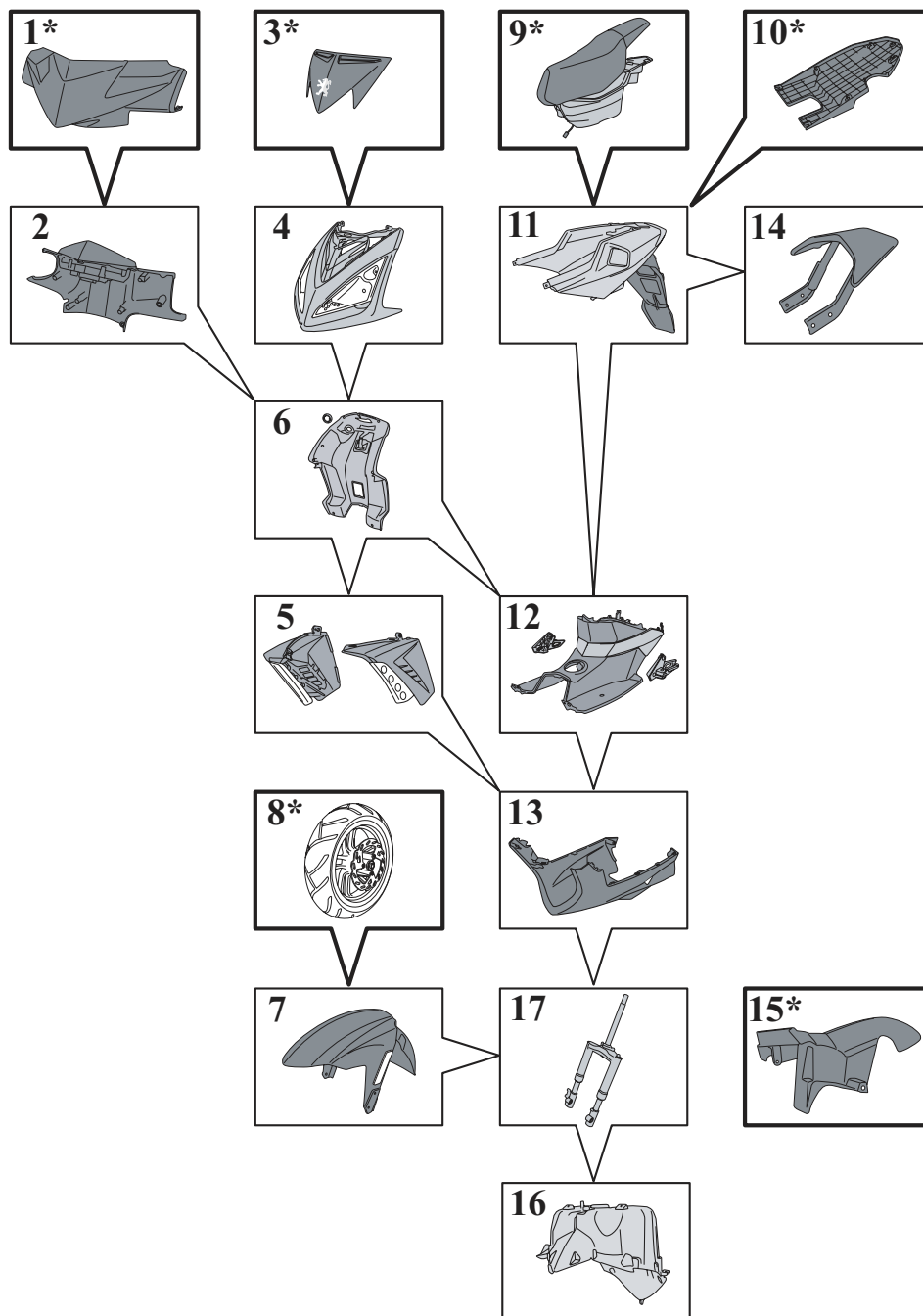

- 1. Handlebar front fairing
- 2. Handlebar rear fairing
- 3. Front top cover panel
- 4. Legshield top panel
- 5. Front lower legshields
- 6. Rear shield
- 7. Front mudguard
- 8. Front wheel
- 9. Saddle and storage compartment

- 10. Lower fairing
- 11. Rear panels
- 12. Footboard
- 13. Bottom panel
- 14. Grab handle
- 15. Rear mudguard
- 16. Mudguard
- 17. Fork

*This item may be removed on its own.

■ Removal of the storage compartment

Procedure 1.

- Lift the saddle.
- Remove the battery cover (1).
 - 2 plastic screws.
- Disconnect and remove the battery.

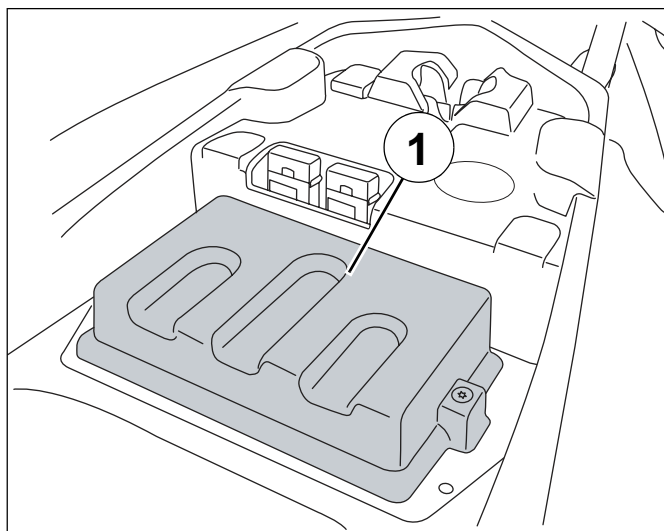

- Remove the storage compartment.
 - 4 washer head screws Ø6 mm.

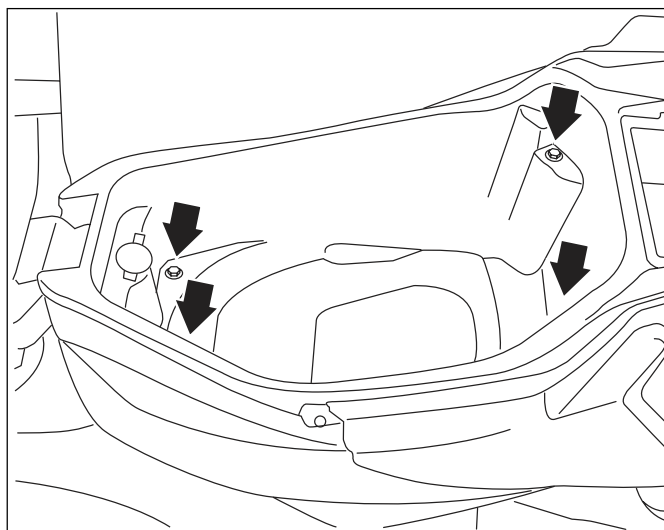

- Disconnect the accessory plug (3).



When reassembling, ensure that the accessory plug supply harness runs IN FRONT of the storage compartment bracket (A).

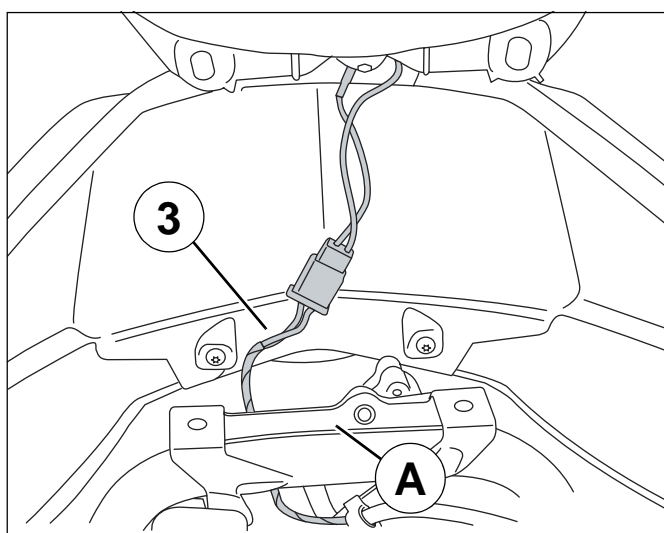

■ **Removal of the rear cover assembly and mudflap**

Procedure 2.

- Remove the storage compartment. See: Procedure 1 page 19.
- Remove the lower fairing by sliding it towards the rear of the vehicle.
 - 1 screw Ø6 mm.

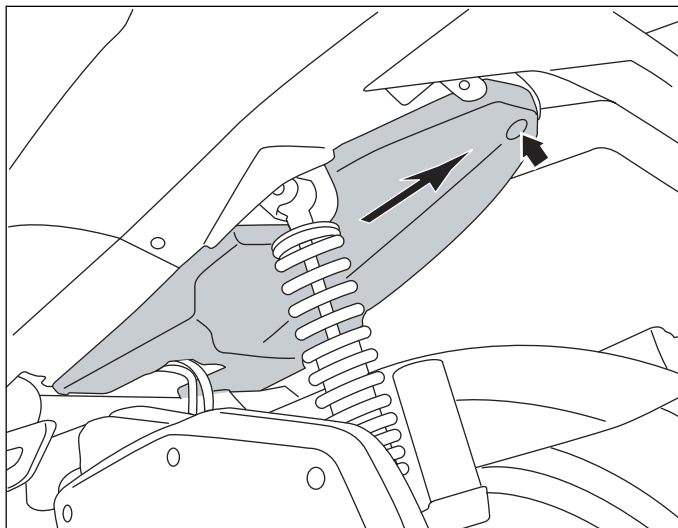

- Remove the rear cover assembly (10 screw).
 - 6 plastic screws (A).
 - 2 screw Ø5 mm (B).
 - 2 screw Ø6 mm (C).

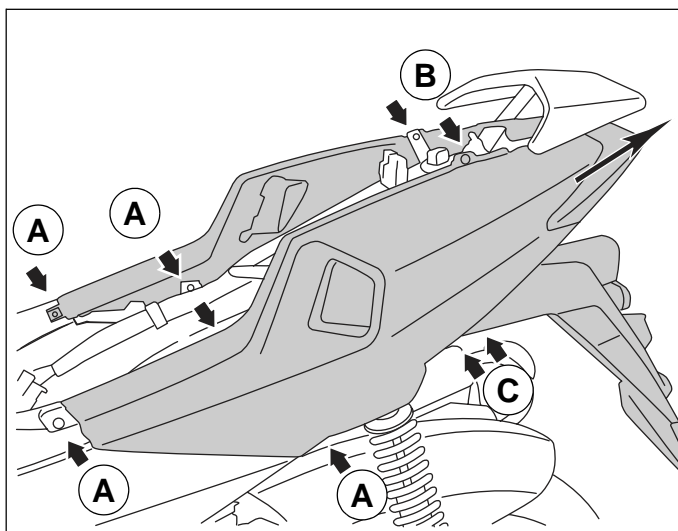

- Disconnect the taillight.

- Remove the splash guard.
 - 4 plastic screws.

- Remove the taillight.
 - 4 plastic screws.

- Separate the 2 fairings (1).
 - 2 plastic screws.

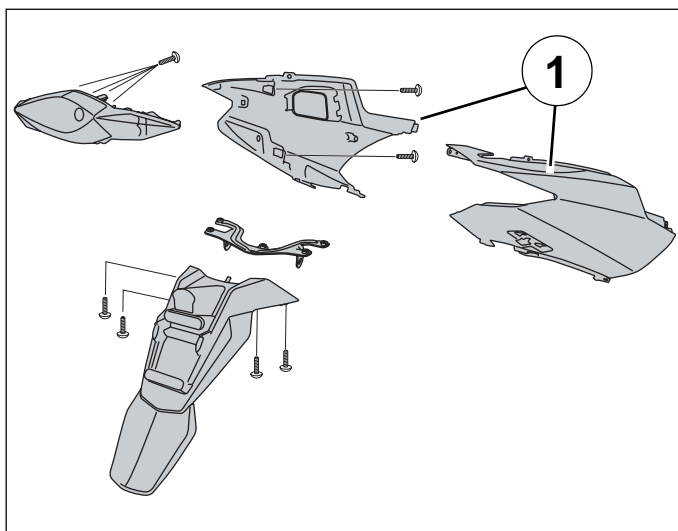

■ Removal of handlebar fairing

Procedure 3.

- Remove the handlebar front cover.
 - 6 plastic screws.

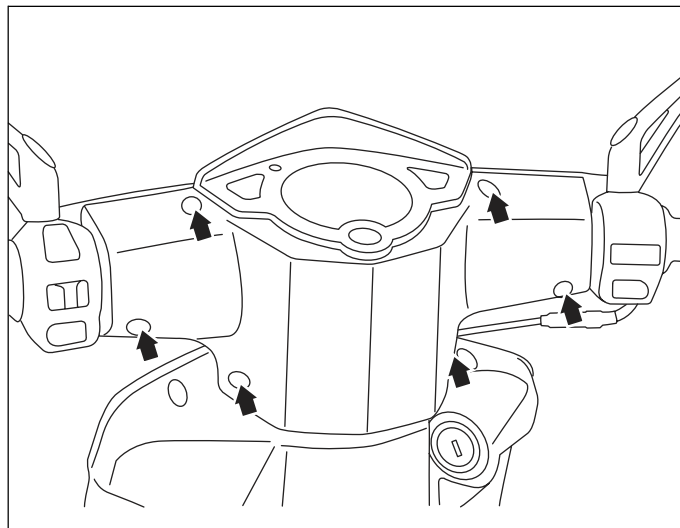

- Disconnect the instrument cluster.
- Remove the handlebar rear cover and instrument cluster assembly.
 - 4 plastic screws.

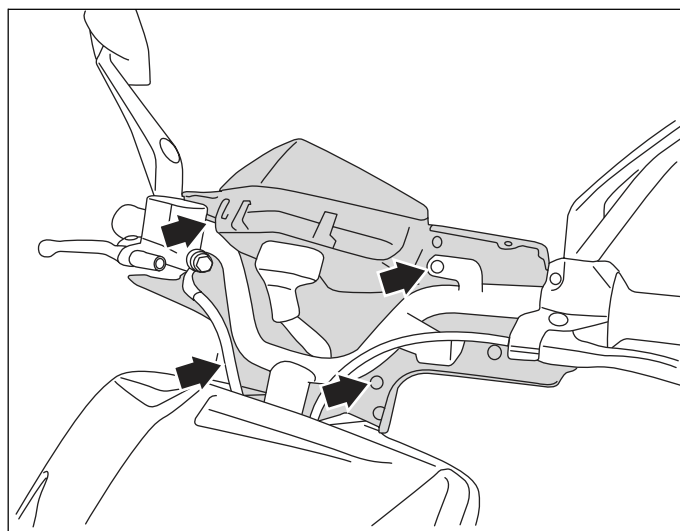

■ **Removal of the front top shield panel**

Procedure 4.

- Remove the front top cover panel.
- 3 plastic screws.

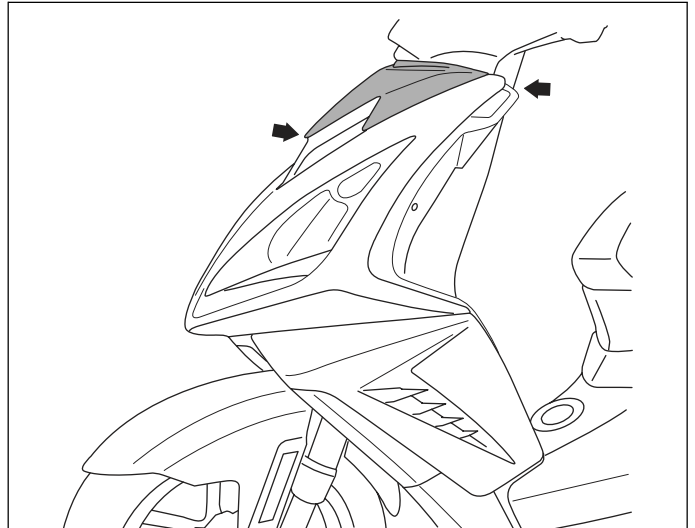

- Remove the front upper shield panel.
 - 4 plastic screws.
- Disconnect the lighting.

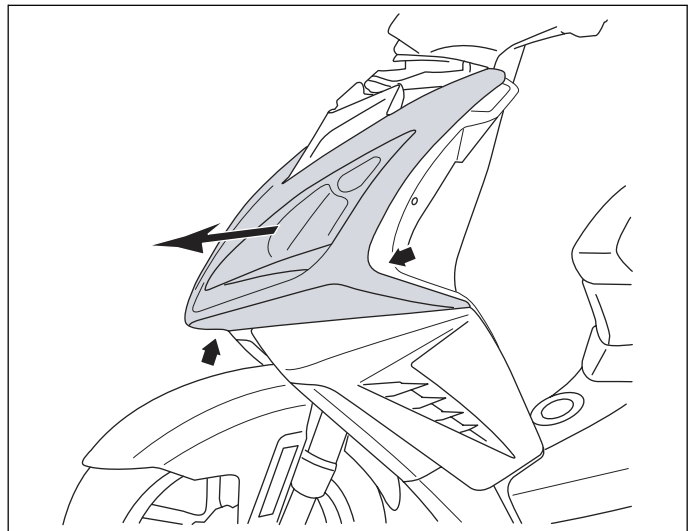

■ **Removal of the rear shield panel**

Procedure 5.

- Remove the handlebar fairings. See: Procedure 3 page 21.
- Remove the front upper shield panel. See: Procedure 4 page 22.
- Remove the rear shield panel.
 - 4 washer head screws Ø6 mm (A).
 - 1 screw Ø6 mm (B).

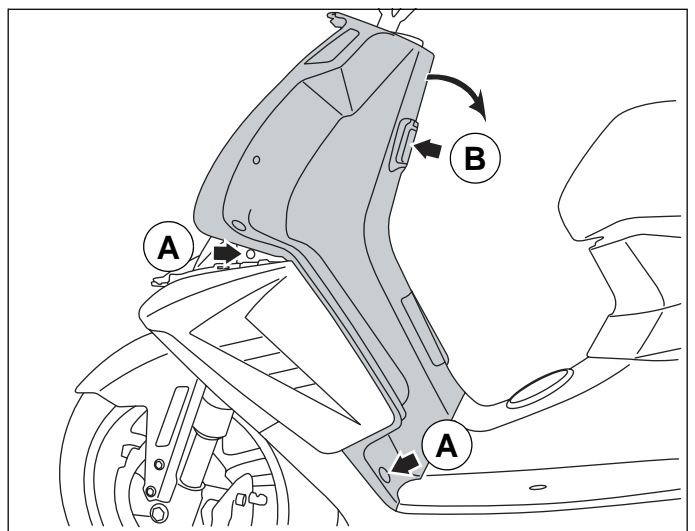



When reinstalling the shield panel, fit the ignition key switch trim with the mark at the bottom (A).

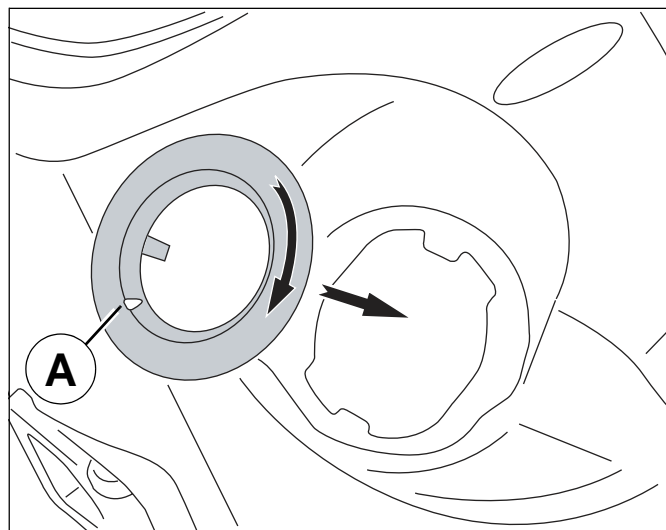

■ Removal of front lower shield panels

Procedure 6.

- Remove the rear shield panel. See: Procedure 5 page 22.
- Remove the front lower shield panels.
 - 3 plastic screws.
- Disconnect the direction indicators.

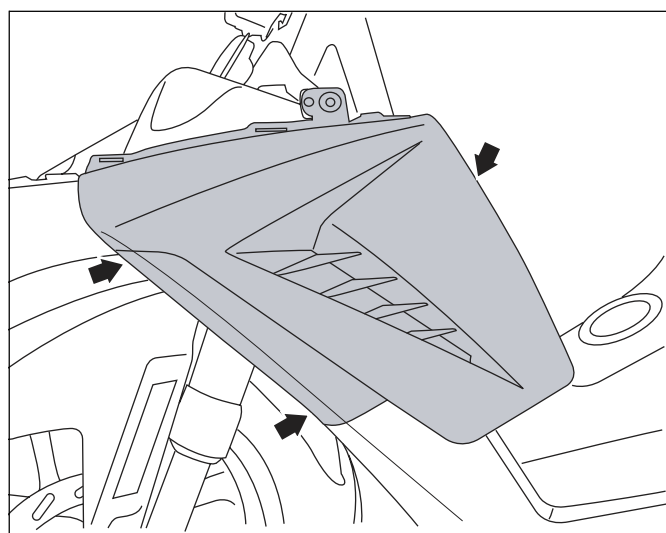

If a direction indicator bulb is changed, the indicator's other bulbs must also be systematically replaced..

■ **Removal of the footboard**

Procedure 7.

- Remove the rear cover assembly. See: Procedure 2 page 20.
- Remove the front lower shield panels. See: Procedure 6 page 23.

- Remove the RH and LH footrest (1) (2 screws each).
- Remove the tank filler cap trim (2) (3 screw).
- Remove the footboard.
 - 4 washer head screws Ø6 mm (A).

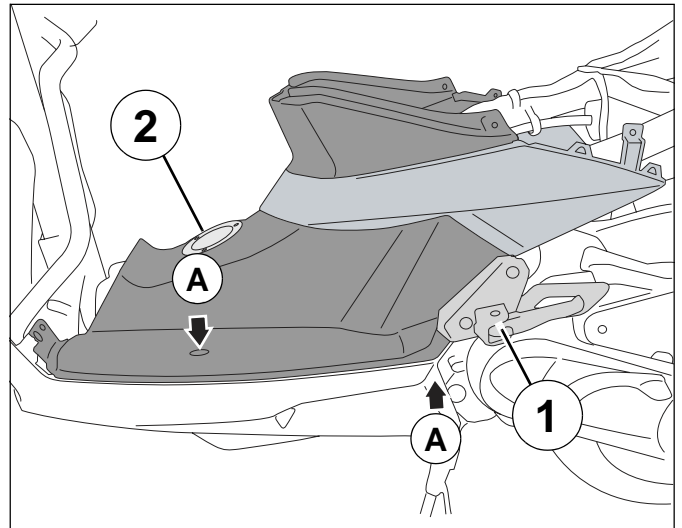

■ **Removal of the under body panel**

- Remove the footboard. See: Procedure 7. page 24.

- Remove the bottom panel.
 - 4 plastic screws

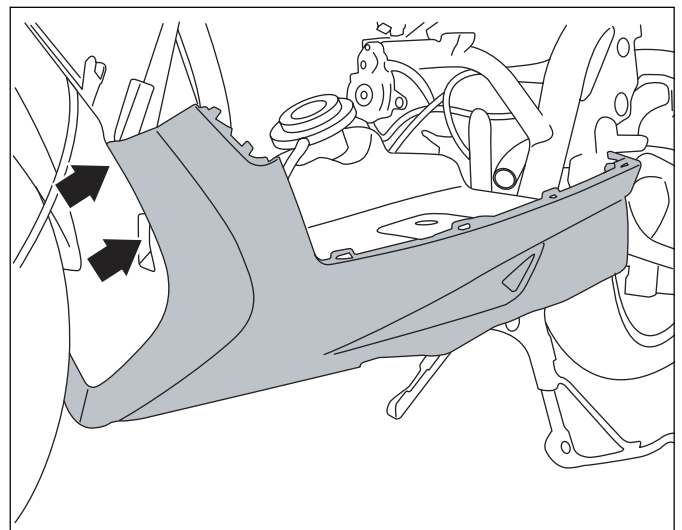

SERVICE OPERATIONS**■ Changing the engine oil**

The engine must be drained when it is warm to allow the oil to run easier.

Put on protective gloves.

- Place the vehicle on its central stand on flat ground.
- Remove the engine's oil filler cap (1).

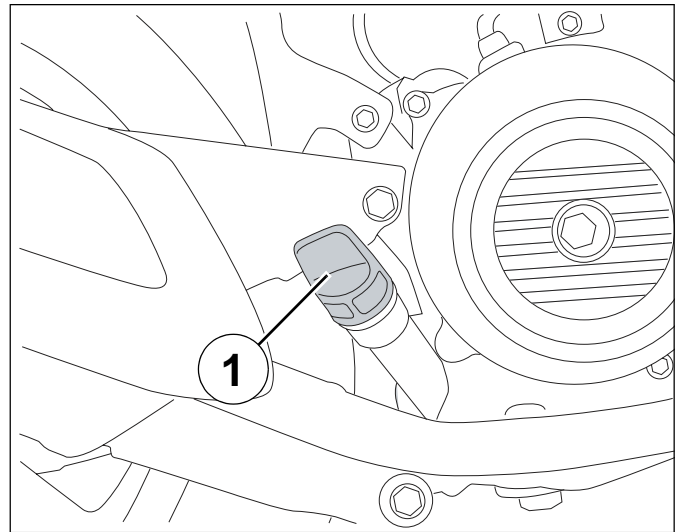

- Remove the drainage cap and its seal (2) and allow the oil to drip into a recipient.

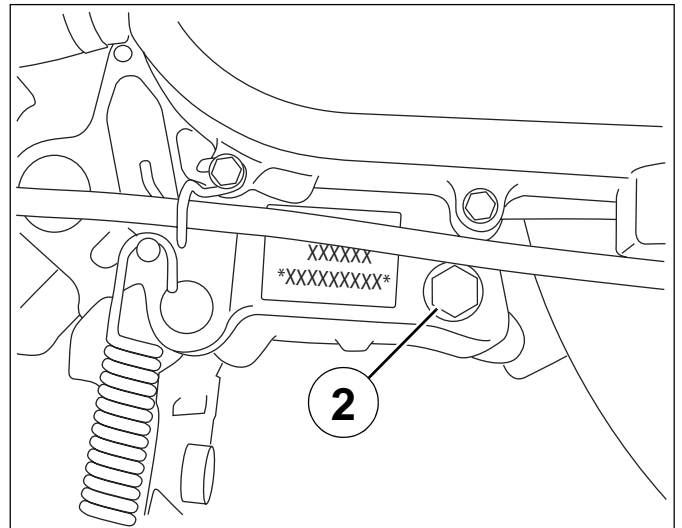

- Remove the strainer cap (3) and clean the strainer.
- Re-install the filter cap fitted with a new seal.

Tightening torque: 15 Nm.

- Insert the drain plug fitted with a new seal.

Tightening torque: 20 Nm.

- Pour the required quantity of oil corresponding to the manufacturer's standards into the filler hole.

Quantity: 0.7 l.

- Start the engine and let it run for a short while.

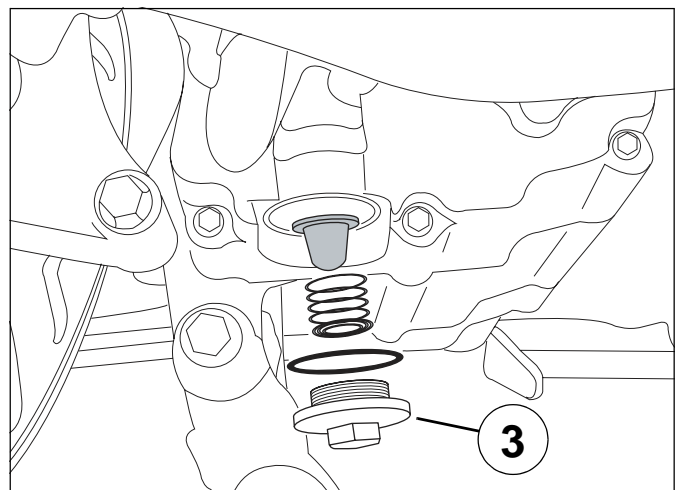

- Remove the engine's oil filler cap/gauge.
- Wipe dry the filler cap/gauge and fit it back but do not screw it into the filler hole.
- Remove the filler cap/gauge and check the oil level.
- The oil level shall not be between the minimum (A) and maximum (B) level marks without exceeding the latter.
- Add oil if necessary.

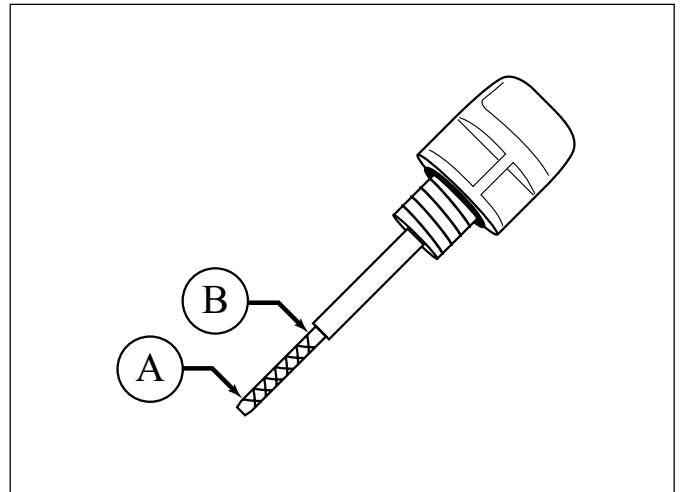

■ Draining the relay box



The gearbox must be drained when the engine is warm so that the oil will run easier.
Put on protective gloves.

- Place the vehicle on its central stand on flat ground.
- Remove the relay box filler cap (1).



- Remove the drainage cap and its seal (2) and allow the oil to drip into a recipient.

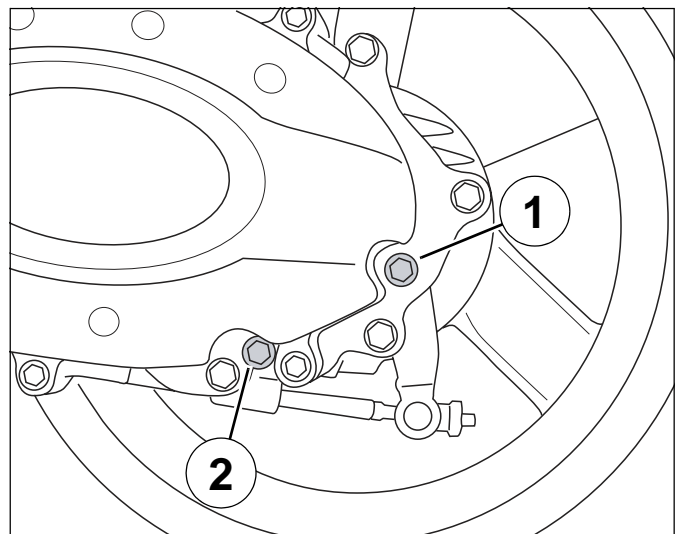

- Insert the drain plug fitted with a new seal.

Tightening torque: 10 Nm.

- Pour the required quantity of oil corresponding to the manufacturer's standards into the filler hole.

Quantity: 0.1 l.

- Fit the filler cap.

Tightening torque: 10 Nm.

■ Removal of the spark plug

- Remove the rear storage compartment. See: Procedure 1 page 19.
- Disconnect the suppressor (1).
- Remove the spark plug using tool P/N 766062.



Essential precautions: When re-installing, screw in the spark plug (a few turns) by hand.

- Tighten the spark plug.

Tightening torque: 12 Nm.

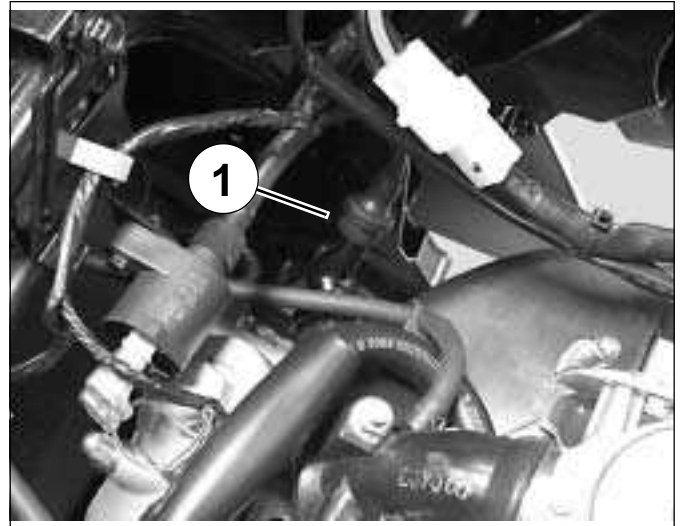

■ Replacing the air filter.

- Remove the air filter cover (7 bolts) and its seal.
- Remove the air filter (1).
- Clean inside the air filter box.

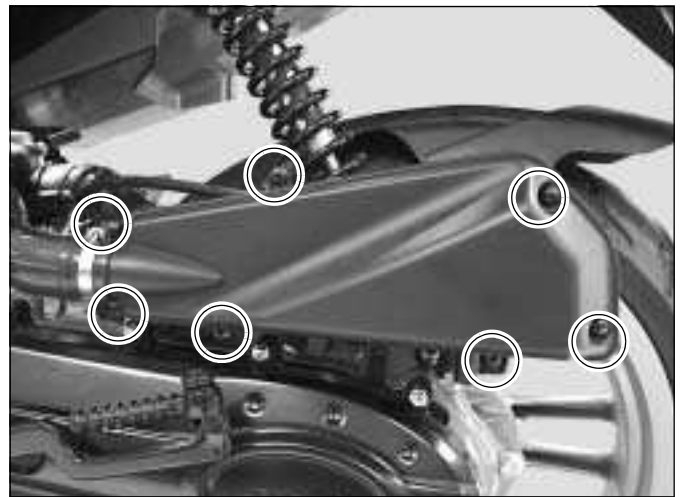

- Fit a new air filter.
- Fit the gasket (2).
- Install the air filter cover.



Check the condition of the seals and make sure they are properly positioned.

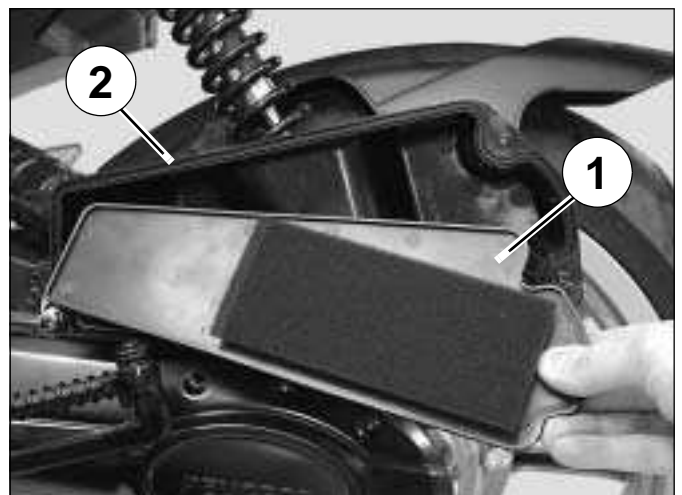

- Remove the inlet silencer drain plug to let humidity and oil drip out (3).

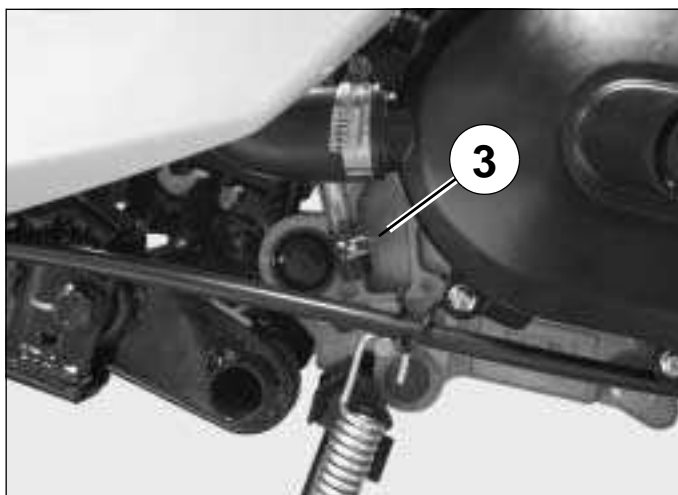

■ **Transmission**

- Remove the transmission cover (10 screw).

Tightening torque: 10 Nm.



- Remove the paper gasket and the two 2 centering pins.

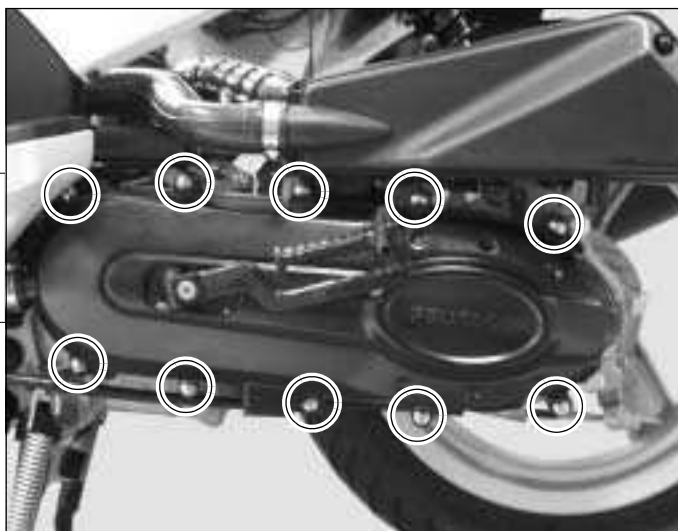

- Hold the fixed flange with tool P/N 752237.
- Remove the fixed flange nut and washer.
- Remove the fixed flange.

Tightening torque: 55 Nm.

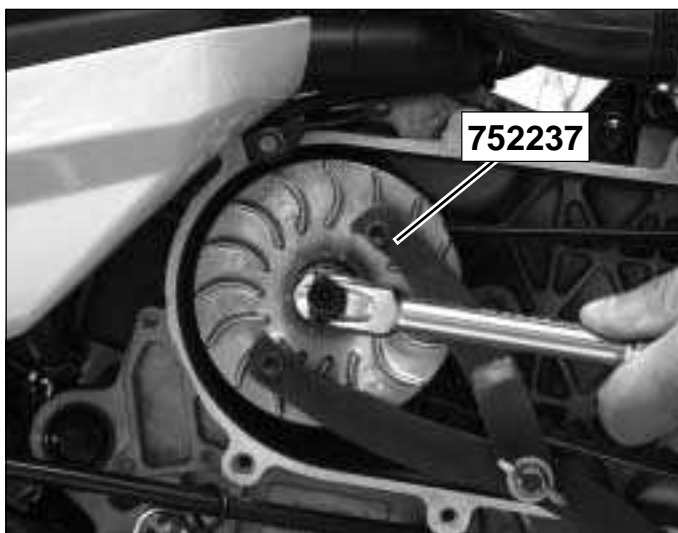

- Remove the belt (1).
- Remove the plastic spacer.
- Remove the drive pulley (2) together with the guide hud.

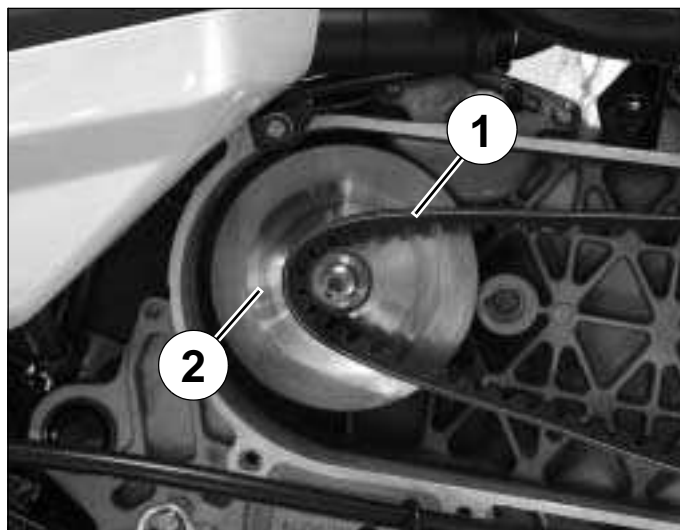

- Lock the clutch drum with the pin wrench P/N 752237.
- Remove the clutch drum and the clutch and drive pulley assembly.

Tightening torque: 55 Nm.

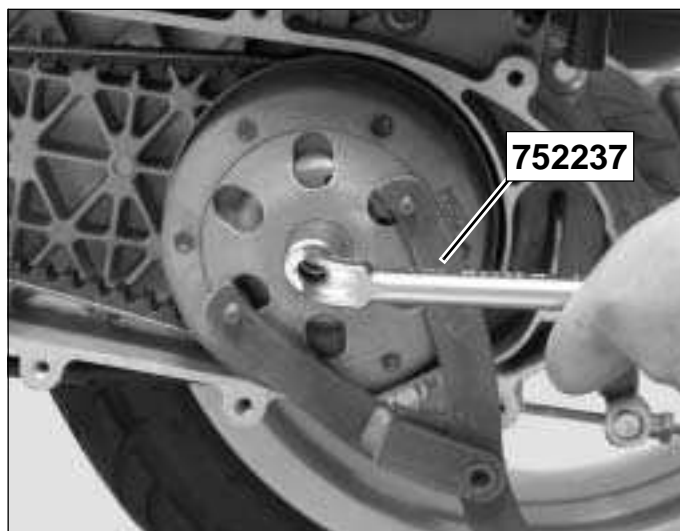

Checking the drive pulley

- Remove the holder (3) and its 3 plastic guides.
- Remove the moving flange (5) 6 bearings (4).
- The bearings must be changed if they show major signs of wear.
- The guides shall be replaced if they show signs of wear.

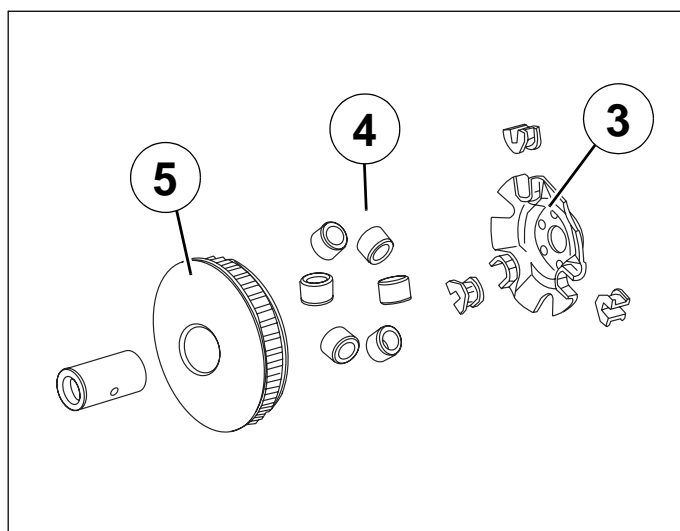

- When refitting, respect the way the rollers are installed.
- Grease the moving flange bore lightly (high temperature grease).

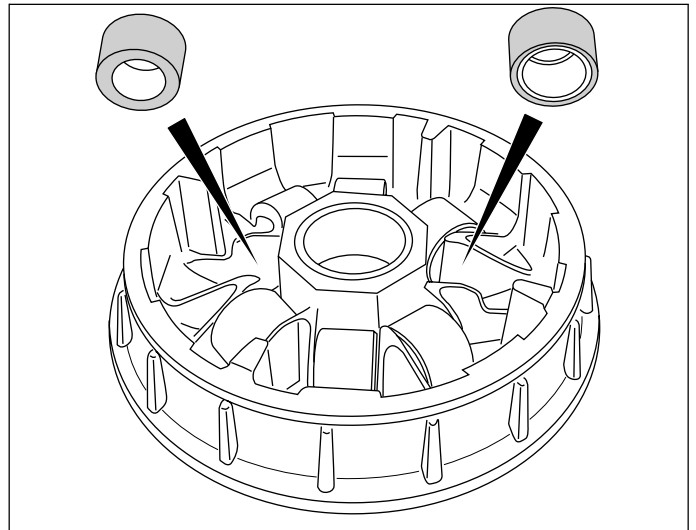

■ **Checking the drive belt**

- Measure the width of the belt (A).

Minimum width: 17.2 mm.

- Make sure the belt is not cracked.

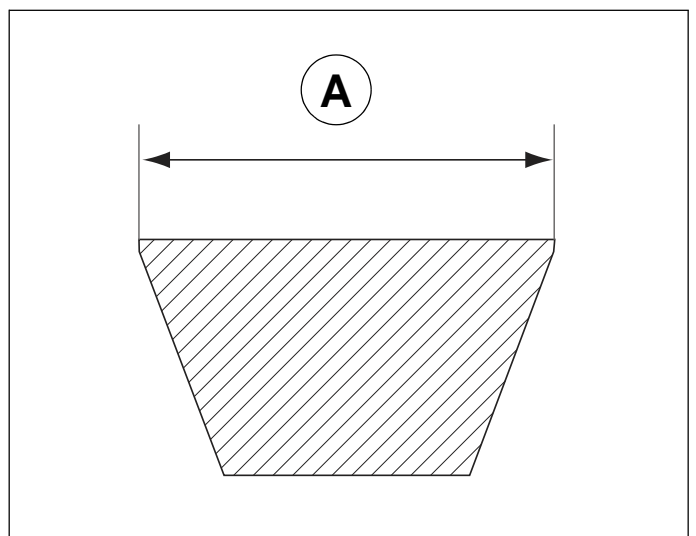

■ Checking the clutch linings

- Using the depth calliper, measure the thickness of the clutch linings.

Mini. thickness 2 mm.

- Make sure surface of the plates in contact with the belt does not show any cracks or signs of abnormal wear.

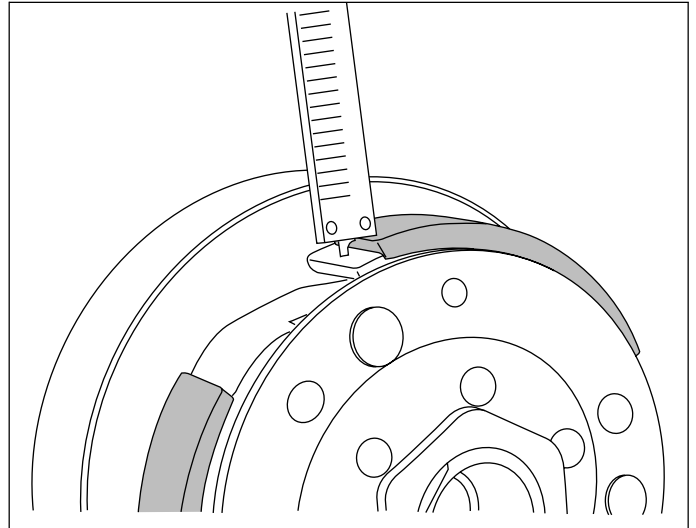

■ Replacing the clutch lining assembly

- Compress the clutch drive pulley and driven pulley assembly with the tool P/N 752127 clamped in the jaws of a vice.
- Remove nut (1) using spanner P/N 752361.
- Slacken tool P/N 752127.

Tightening torque: 55 Nm.

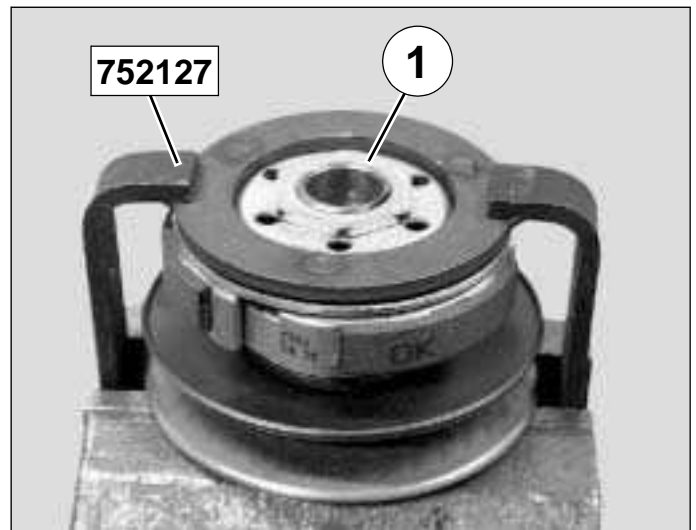

- Remove the clutch lining assembly (2).
- When re-installing the driven pulley, lubricate the needle bearing (3).

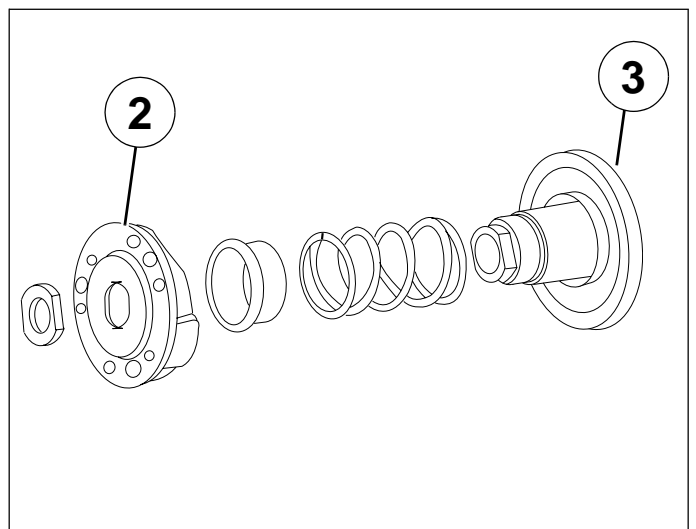

■ Installing the valve clearance

- Remove the power unit. (See page 55).
- Remove the valve clearance adjustment covers.

	<p>Apply the correct tightening torque to the valve clearance adjustment covers.</p>
	<p>Tightening torque: 15 Nm.</p>

- Rotate the engine by hand in the operating direction in order to bring the rocker pads on the back of the cams (A).
- Using the set of feeler gauges, measure the clearance of each valve.

Clearances:

- Intake: 0.05 ± 0.02 mm.
- Exhaust: 0.10 ± 0.02 mm.

- If the clearance is not correct, adjust by means of the cam follower screw.
- Use a wrench to adjust the valve clearance. Type: Marolotest, P/N 500140.

Checking the valve clearance

- At the intake a 0.10 mm feeler gauge shouldn't go.
- At the exhaust a 0.15 mm feeler gauge shouldn't go.
- On the contrary, if the feeler gauge goes, reset the clearances.

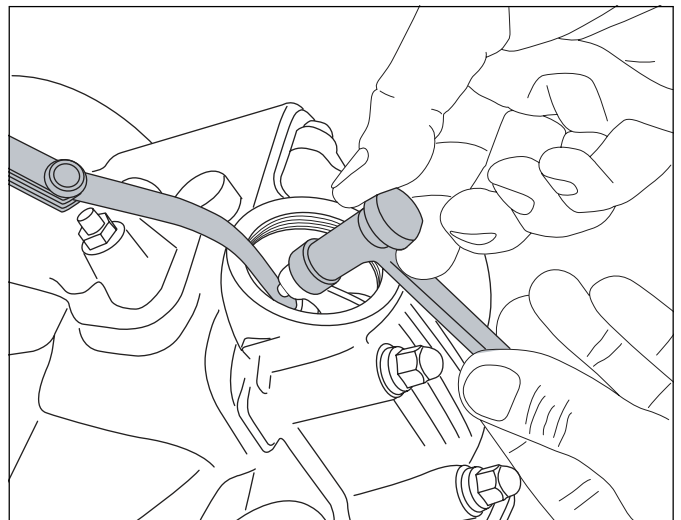
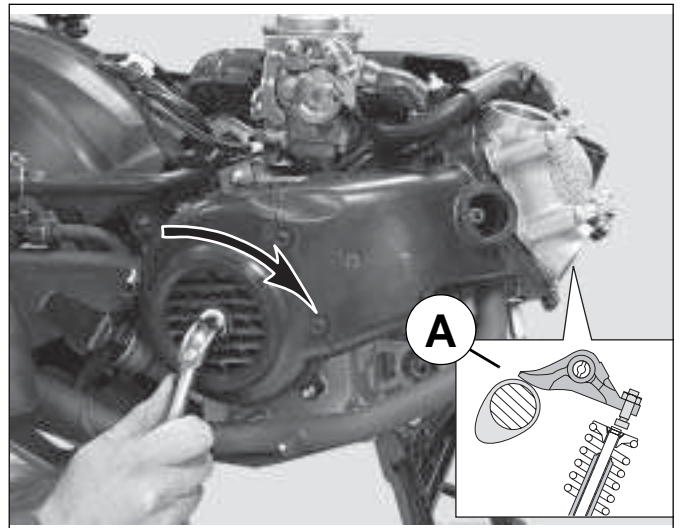

■ Idle setting

- Remove the storage compartment. See: Procedure 1 page 19.
- The engine must be at its operating temperature.
- Switch off the engine.
- Park the vehicle on its stand.
- Check the operating clearance in the throttle.
- Start the engine.
- Screw or unscrew the engine speed adjuster screw (1) to alter the idle speed.
- The rear wheel should not turn.

Idle speed: 2000 to 2200 rpm.

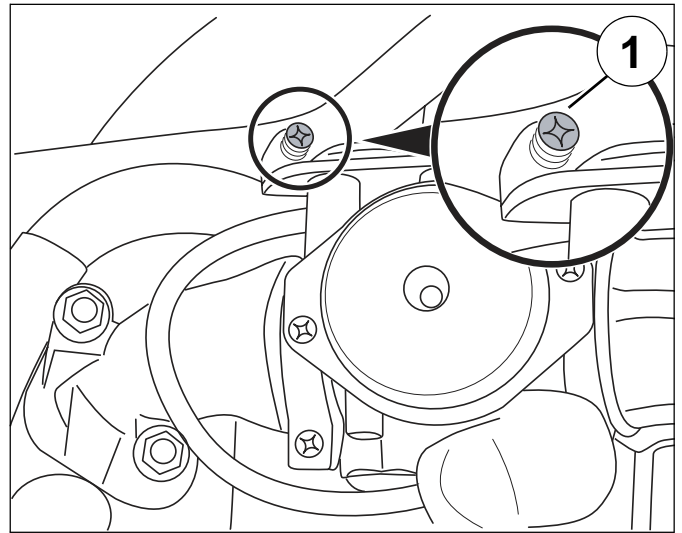

■ **Brake inspection**

- If one of the 2 brake pads is worn down to the minimum dimensions (A), the 2 brake pads must be changed.

A. Mini. thickness: 1.5 mm.

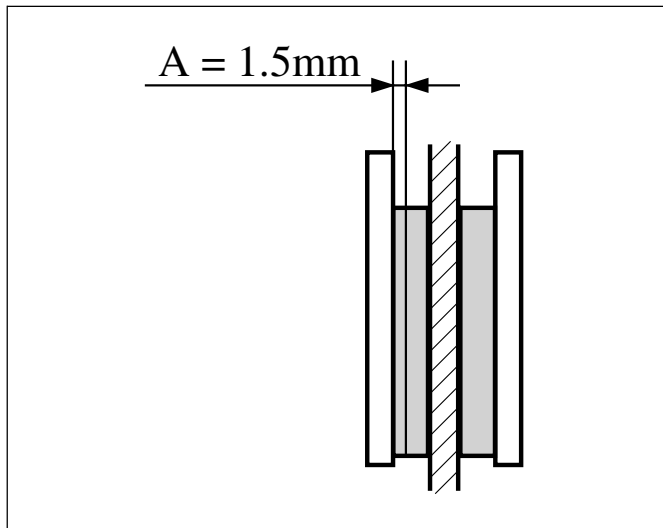

■ **Replacing the brake pads**

- Remove the calliper (2 screw).

Tightening torque: 45 Nm.



- Remove the 2 pins (1).
- Remove the brake pads (2).

	When refitting the brake pads, push the pistons all the way into their housing.
	After refitting, actuate the brake levers several times to bring the brake pads against the brake disc.

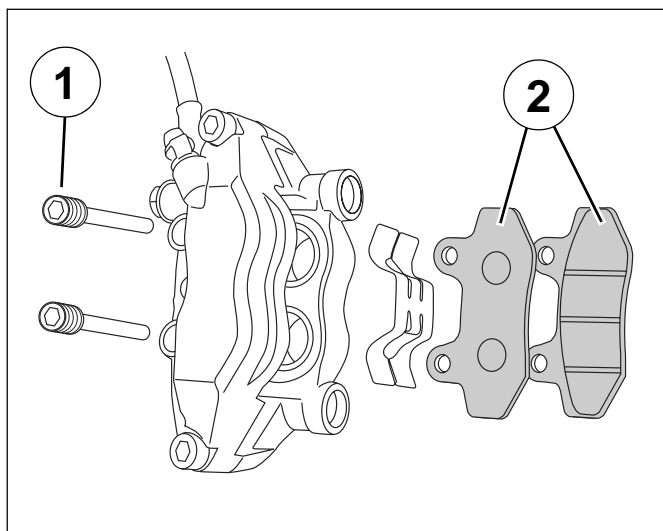

■ Checking the brake fluid level

- Position the handlebars so that the master cylinder will be horizontal.
- Check the brake fluid level and if necessary top up in the master cylinder (A).

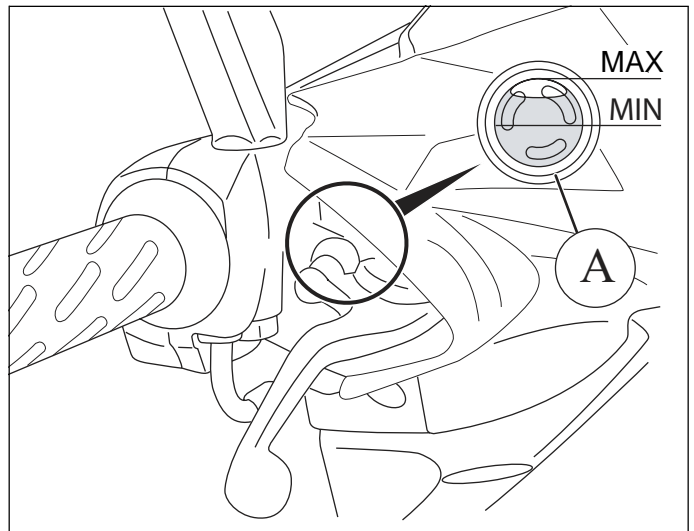

- Remove the handlebar front cover (6 screw).
- Remove the cover and the diaphragm from the master cylinder (1) (2 screw).
- Add brake fluid until it reaches the maximum level.

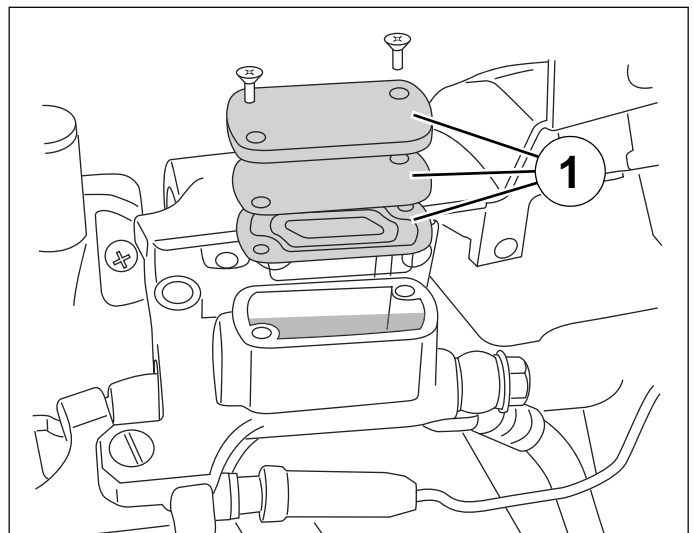

■ **Rear brake linings**

- Actuate the brake control lever and check the position of the wear mark on the cam tierod (A) compared to the mark (B) on the engine housing.
- If the cam tierod mark is lined up with or passes the wear mark on the engine housing, the brake lining must be replaced.
- When it is no longer possible to adjust the control tension nut, the brake pads are worn (C).

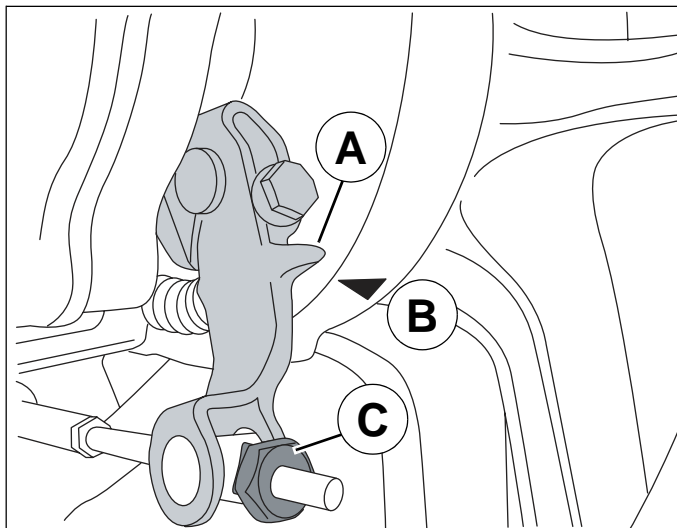

Disassembly

- Remove the 2 nuts attaching the exhaust flange to the cylinder.



- Disconnect the air hose from the exhaust (1).
- Remove the exhaust (2 screw).



- Remove the wheel spindle nut and washer (2).
- Remove the rear wheel.

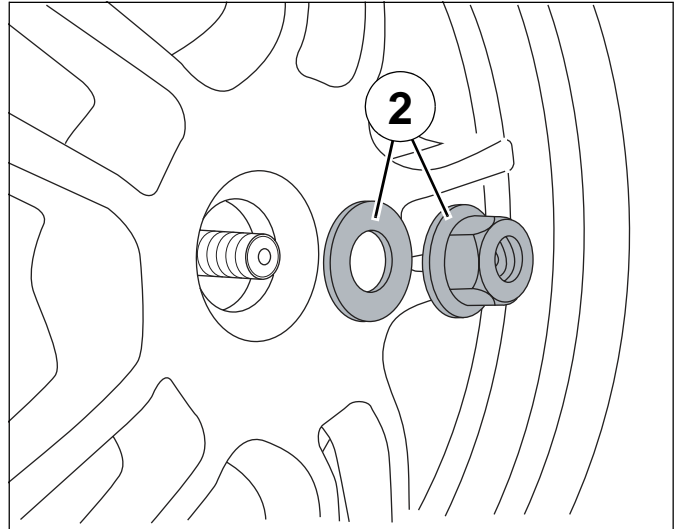

- Remove the brake linings (3).
- Remove the adjusting nut, the barrel (4) and the brake control cable (5).
- Remove the brake arm (6), the brake cam (7) and the spring.

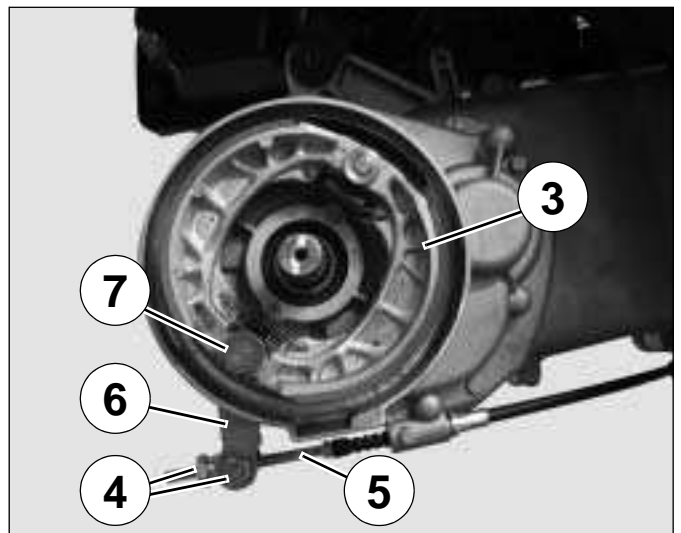



Reassembly

	<p>Lubricate the brake cam spindle and fit it into the casing.</p>
--	--

- Fit the brake arm (6) by aligning it with the brake cam axis (7).

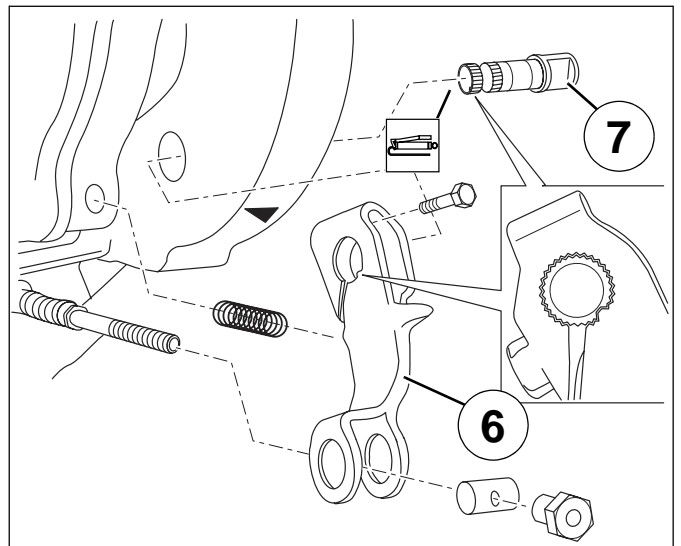
Tightening torque: 8 Nm.



	<p>Slightly lubricate the brake cam and pin.</p>
---	--

- Install the brake linings.
- Install the spring (8).
- Install the brake control cable, the barrel and the adjusting nut (4).
- Install the wheel.

Tightening torque: 120 Nm.

	<p>When re-installing, use a new nut.</p>
---	---

- Measure the free travel of the rear brake control lever.
- Adjust the lever free travel using the adjusting nut.

C. Brake control free travel: 10 to 20 mm.

- Install the exhaust.

	<p>Use a new exhaust gasket.</p>
---	----------------------------------

- Exhaust to cylinder mounting nut:

Tightening torque: 15 Nm.

- Exhaust to casing mounting bolt:

Tightening torque: 30 Nm.

■ Removal of the fuel filter

- Remove the footboard. See: Procedure 7 page 24.
- Lift the fuel tank.
- Clamp the end of the fuel inlet pipe using a clip ref. 755996.
- Disconnect the fuel supply hose (1).
- Remove the fuel filter (2).

	<p>When re-installing, respect the direction of installation of the filter shown by the arrow which indicates in which direction the fuel flows.</p>
---	---

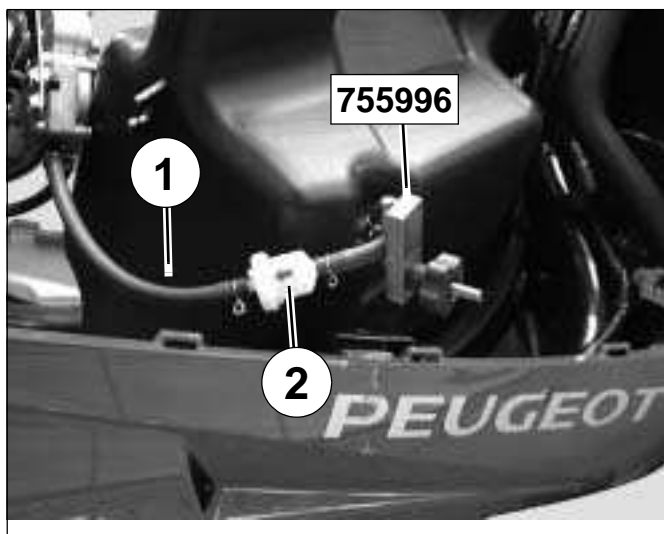
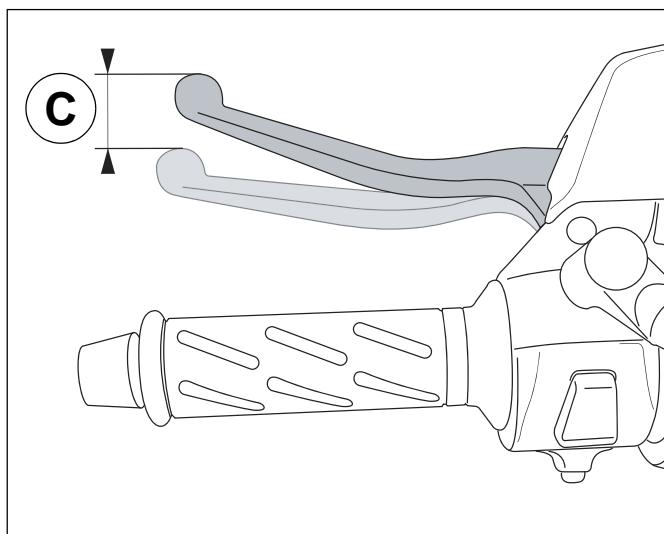
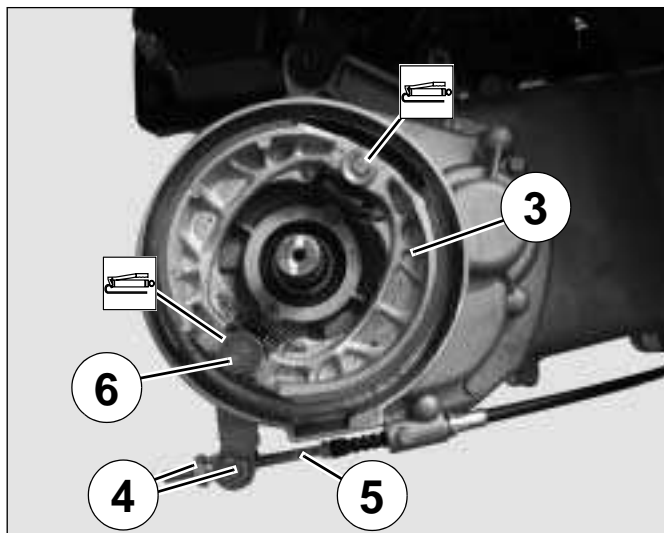

STEERING/FORK**■ Changing the front fork seals**

- Suspend or immobilize the machine securely.
- Remove the front brake caliper from the fork tube (2 screw).
- Loosen the wheel spindle clamping screw (1).
- Remove the wheel spindle (2).
- Remove the front wheel.
- Remove the front mudguard (4 screw).

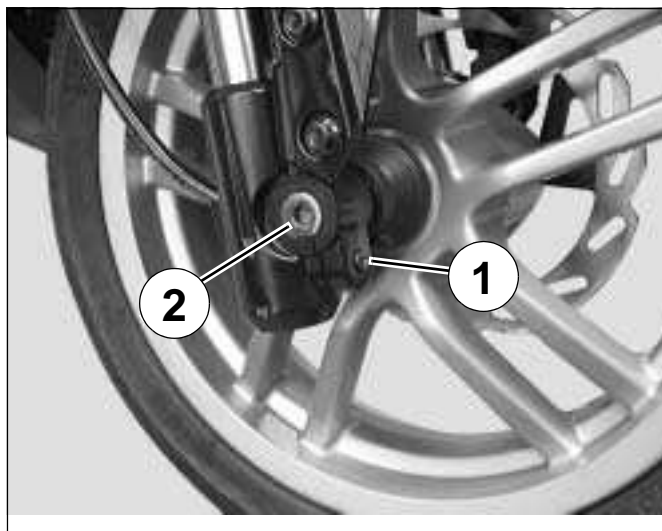

- Remove the screws fastening the fork stanchions (3).
- Remove the fork stanchions.

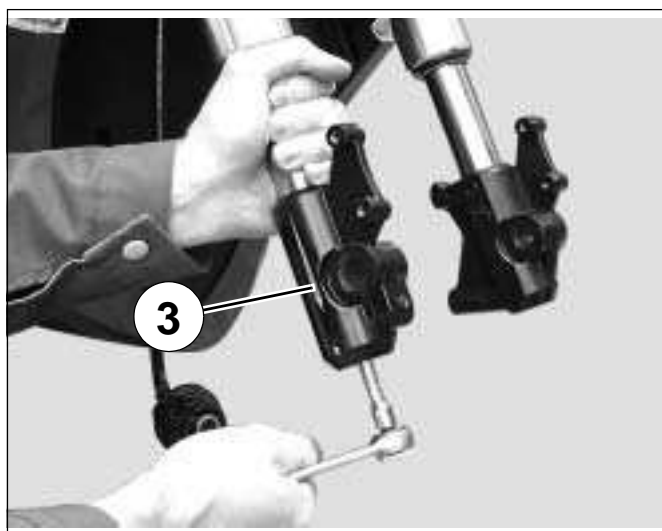

- Carefully remove the lip seals using a screwdriver (4).
- Install new lightly lubricated lip seals.
- Fit the fork stanchions.

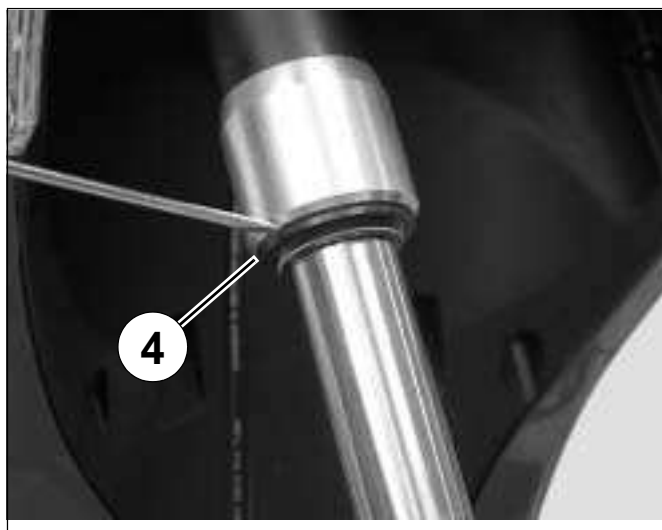

Tightening torque: 25 Nm.

- Fit the front mudguard.
- Fit the speedometer drive gear assembly to the wheel drive pins.
- Fit the wheel, matching the speedometer drive gear assembly to the pin (A) on the fork stanchion.
- Fit the wheel spindle and tighten.

N

When re-installing, use a new nut.

Tightening torque: 65 Nm.

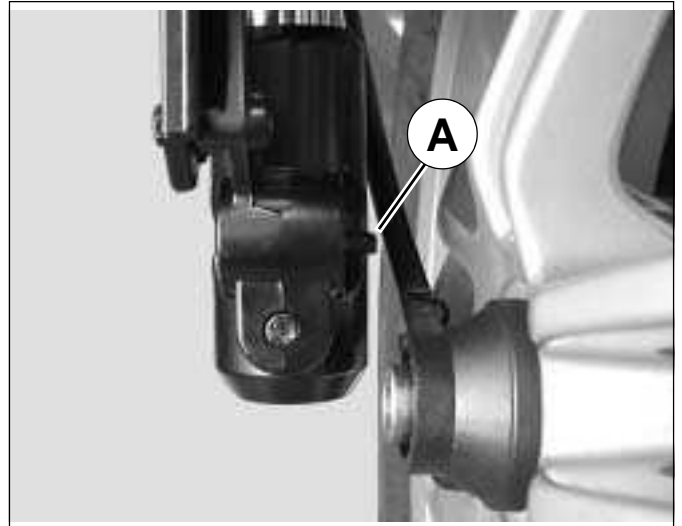

- Tighten the spindle clamping screw (1).

Tightening torque: 10 Nm.

- Refit the other items in the reverse order to disassembly.

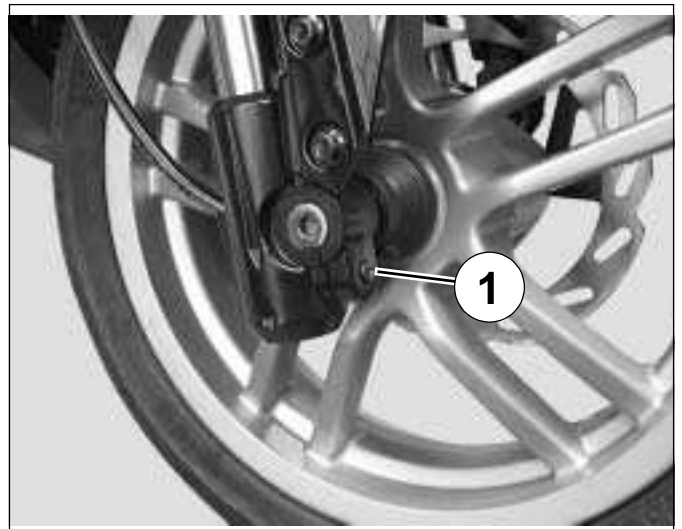

■ Removal of the fork tubes

- Remove the front upper shield panel. See: Procedure 4 page 22.
- Turn the handlebars to the right to reveal the fork nut (1) in the hold in the mudguard.

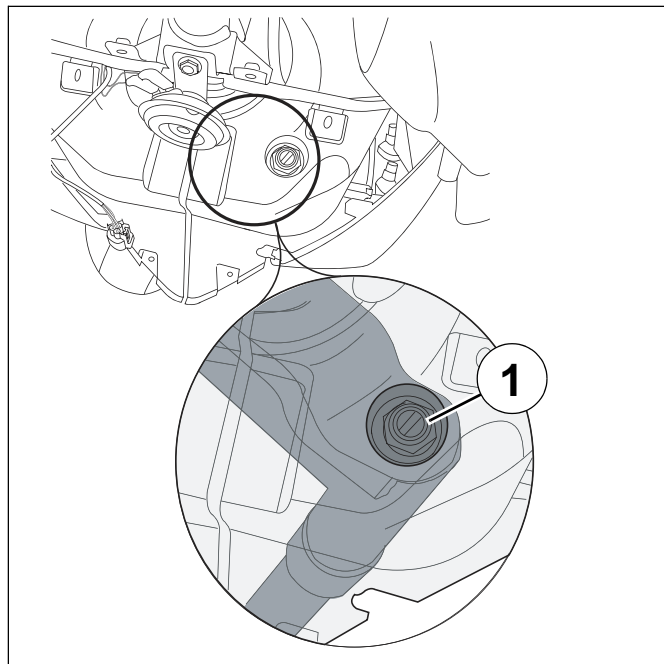

- Support the hydraulic cartridge cylinder and remove the nut (Left side).

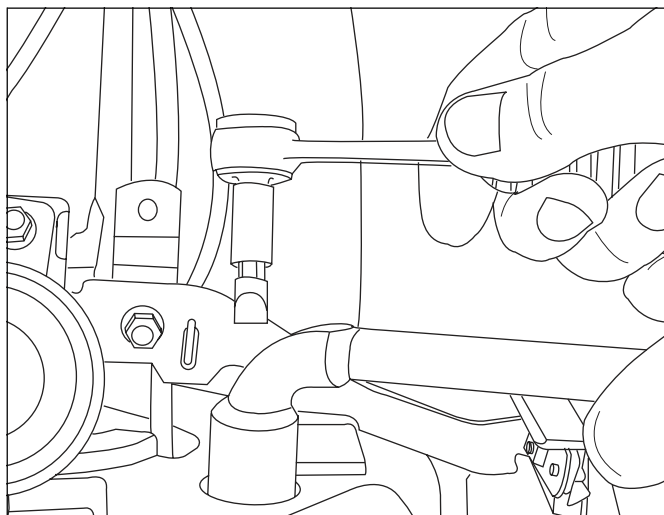

- Carefully remove the lip seals using a screwdriver (2).
- Remove the circlip, using a circlip plier (3).
- Remove the fork tubes.
- Remove the springs.
- Remove the rubber stop.
- When refitting, lightly grease the balk rings (5).

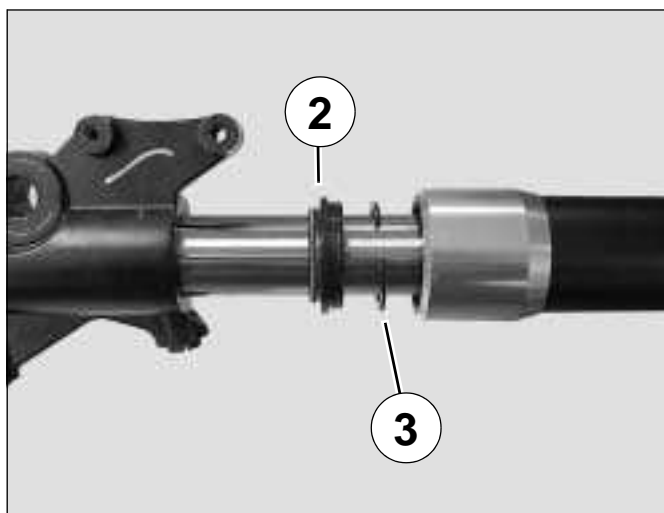

■ The fork and its components

1. Hydraulic cartridge nut.
2. Lip seal.
3. Circlip.
4. Rubber washer.
5. Balk rings.
6. Expansion spring.
7. Fork lower tube.
8. Compression spring.
9. Rubber stop.
10. Hydraulic cartridge.
11. Stanchion.



After refitting, pump the forks several times to eliminate the excess grease inside the tubes.
Wipe the grease off the fork tubes.

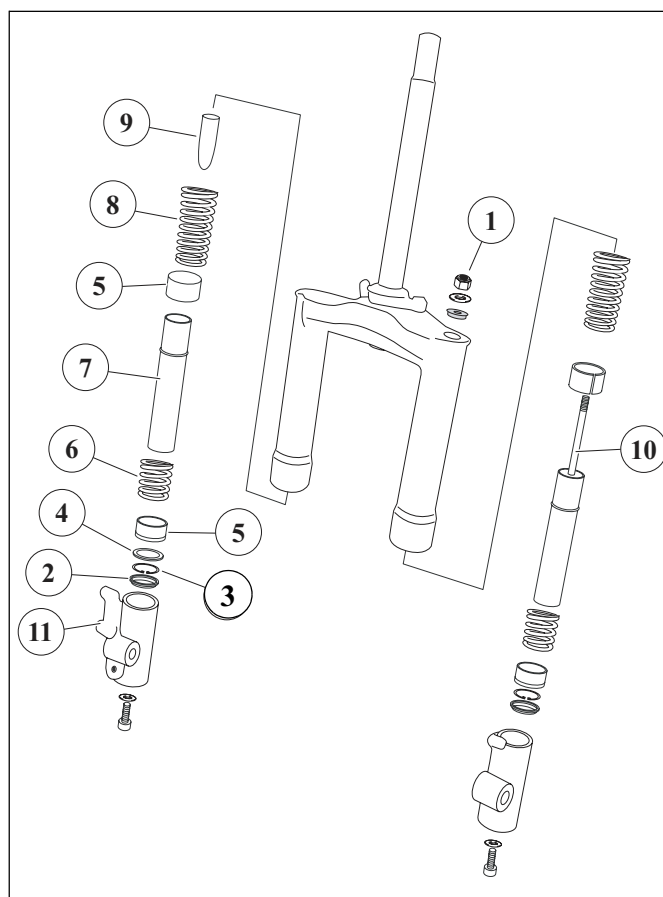

■ Removal of the fork

- Remove the rear shield panel. See: Procedure 5 Page 22.
- Remove the handlebars from the fork tube. (1 screw and 1 nuts) (1).

N

When re-installing, use a new nut.

Tightening torque: 40 Nm.

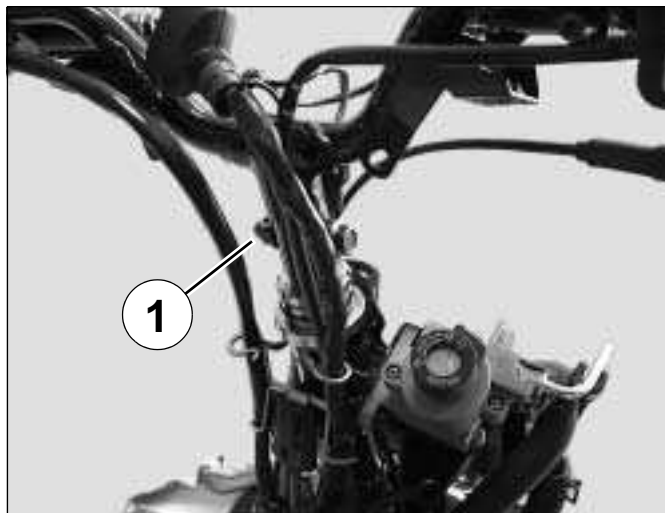

- Suspend or immobilize the machine securely.
- Remove the front brake caliper from the fork tube.

Tightening torque: 45 Nm.

- Remove the front wheel.

Tightening torque: 65 Nm.

N

When re-installing, use a new nut.

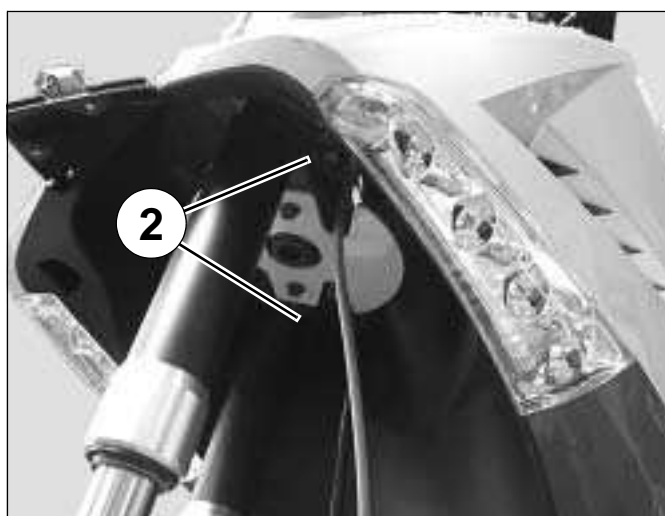

- Remove the front mudguard.
- Remove the brake control cable grommet and the speed sensor located under the fork triple clamp (2) (2 screw).
- Using tool P/N 757860 remove the steering locknut.
- Remove:
 - The lock washer.
 - The nut.
 - the rubber washer.
 - The nut.
 - The dust cover.
 - The upper cone.
- Remove the fork.
- Remove the caged ball bearings.

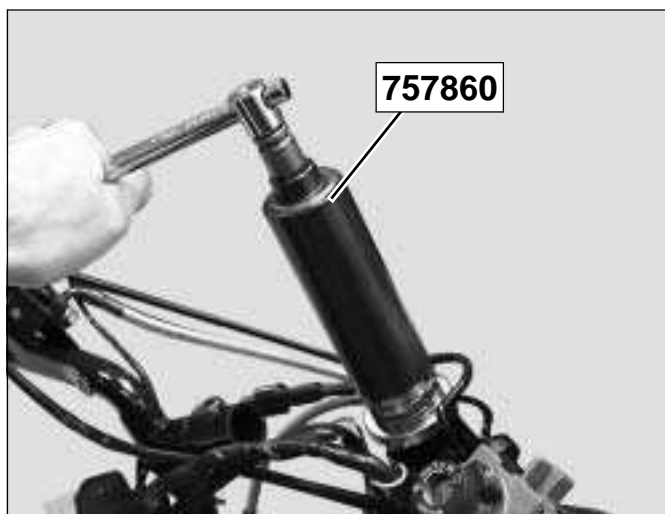

■ Replacing the steering head cups

- Replacing the steering head cups.
- Using a drift, remove the steering head cups.



- Using push tool P/N 753726, fit a new upper cup into the steering tube.
- Using push tool P/N 757990, fit a lower cup into the steering tube.



- Using a chisel, pry the steering head cup off by pressing the tool behind the dust cover.
- Install the following new parts:
 - The dust cover (3).
 - The fork cone (4).

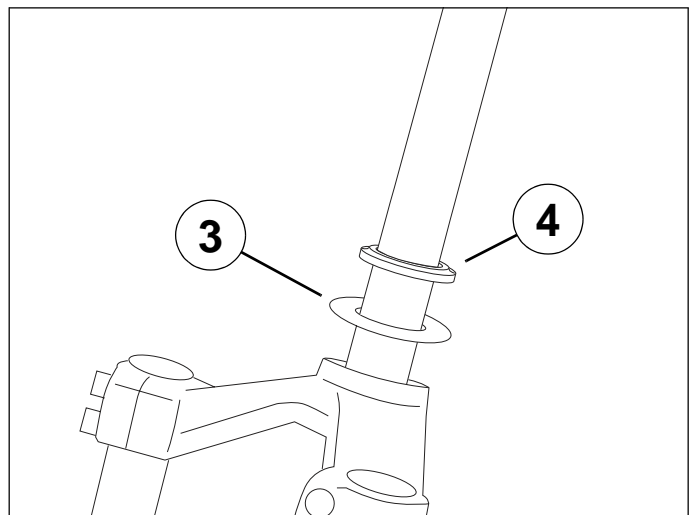

■ Installing the fork

- Grease the cup bearing races.
- Install new ball cage bearings (1) (respect the right way of installation).
- Fit the fork into the steering column.

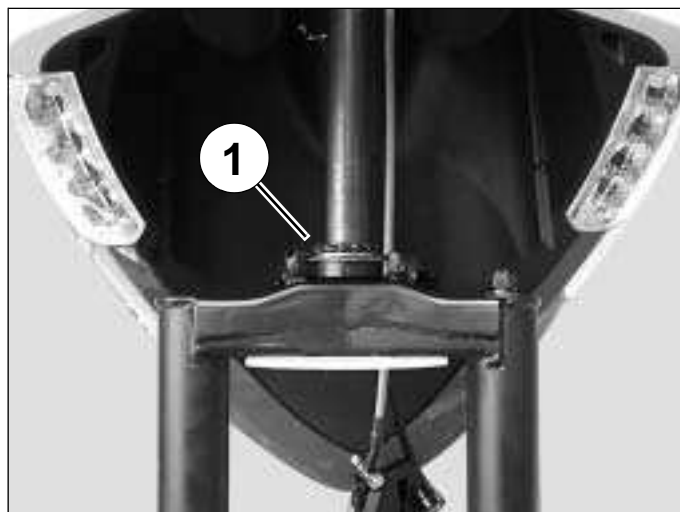

- Install new ball cage bearings (2) (respect the right way of installation).
- Install the upper cone (3).
- Install the dust cover (4).
- Fit the nut (5).

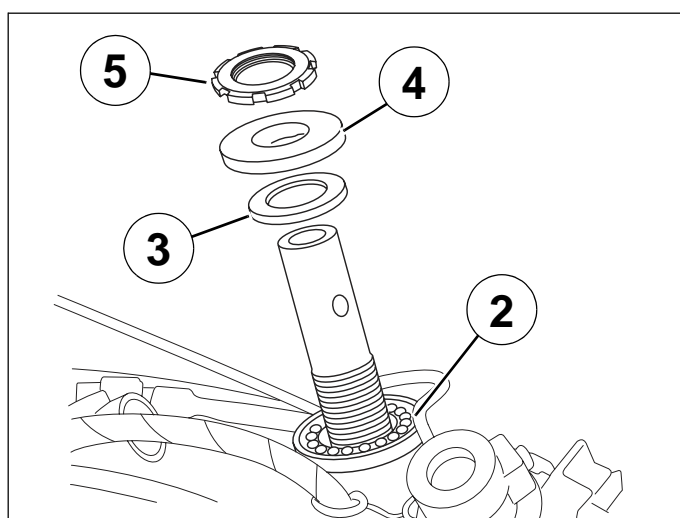

■ Steering system tightening method

- Tighten the nut (5).

Tightening torque: 40 Nm.

- Loosen and re-tighten the nut.

Tightening torque: 17 Nm.

- Install the rubber washer (6).
- Fit and finger tighten the nut (7) so that its notches are aligned with those of the nut.
- Fit the lock washer (8) in the notches of the 2 nuts.

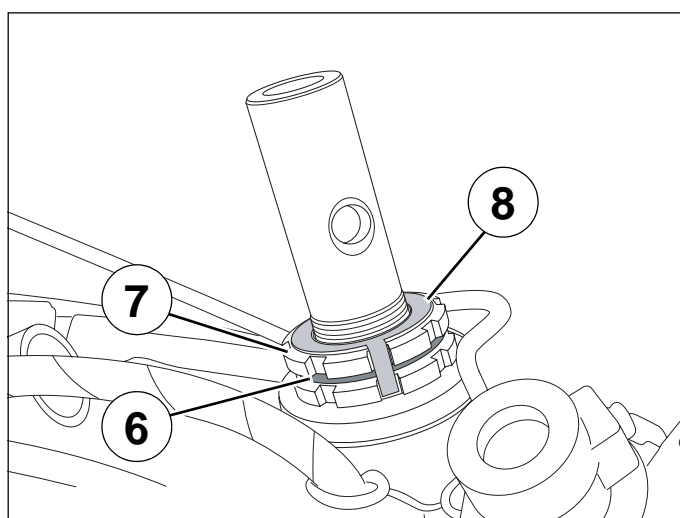

- Install the steering head locknut and tighten it (9).

Tightening torque: 70 Nm.

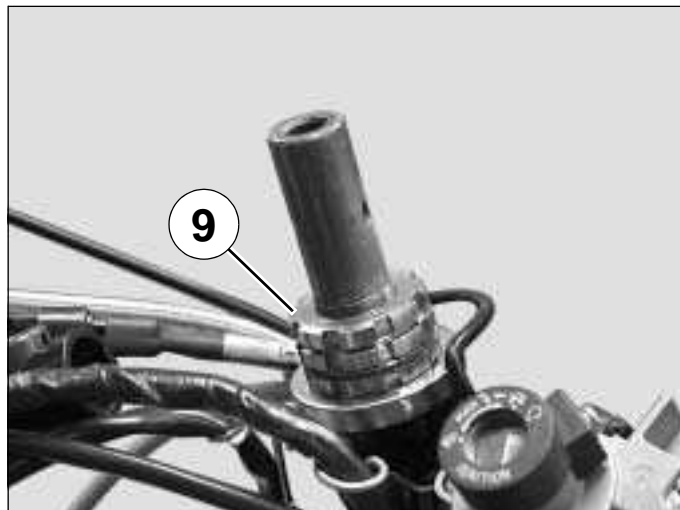

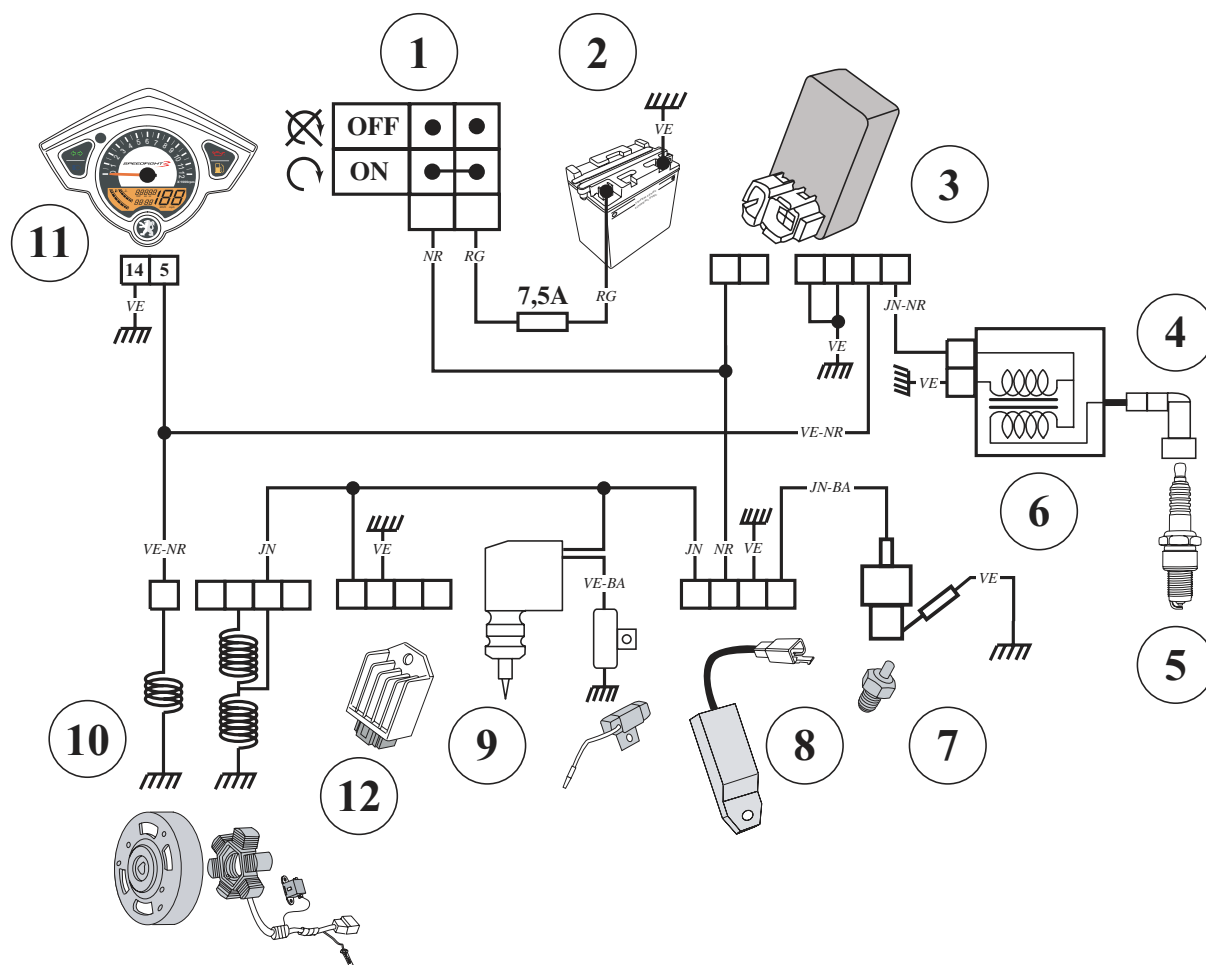
ELECTRICITY**■ Ignition principle schematic/Carburetor heater**

- | | |
|-----------------------|------------------------------|
| 1. Ignition switch. | 7. Carburetor heater. |
| 2. Battery. | 8. Temperature control unit. |
| 3. CDI unit. | 9. Automatic starter. |
| 4. Spark plug socket. | 10. Magneto flywheel. |
| 5. Spark plug. | 11. Revolution counter. |
| 6. HT coil. | 12. Regulator. |

■ Temperature control unit/Regulator/Starter motor relay/Ignition unit

- Remove the storage compartment. See: Procedure 1 page 19.
- Remove:
 - Regulator (1).
 - The starter motor relay (2).
 - The ignition module (3).
 - The temperature control unit (4).

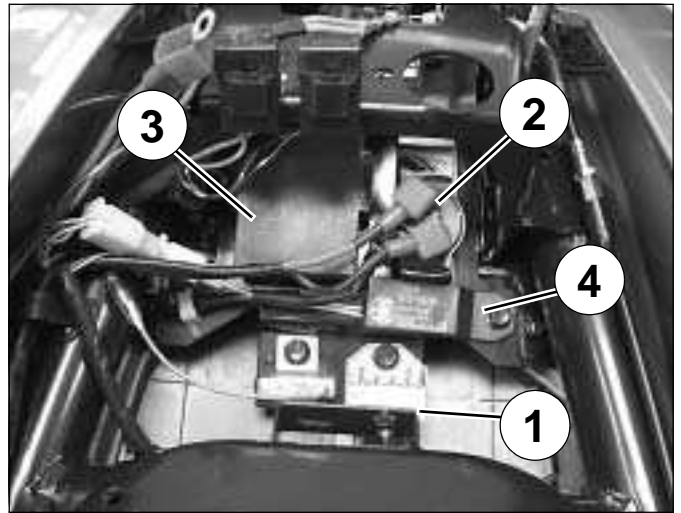

■ Checking the carburettor heating circuit

Power supply range of the carburettor heating resistor:

Between $10^{\pm 2}$ and $20^{\pm 2}$ °C.

Disconnect the temperature control unit and take the measurements on the harness side.

- Between the green wire and the ground: 0 Ω.
 - Between the white/yellow wire and the ground (Resistor warming carburator): $8.5 \Omega^{\pm 20\%}$.
 - Between the black wire and the ground, ignition on: 12 V (Battery voltage).
 - Between the yellow wire and the ground, engine running: 13.5 V (Regulated alternating current).
- If the values are correct, replace the temperature control unit.
 - If the values are incorrect, check:
 - The harness.
 - The ignition switch.
 - The carburettor heating resistor: $8.5 \Omega^{\pm 20\%}$.

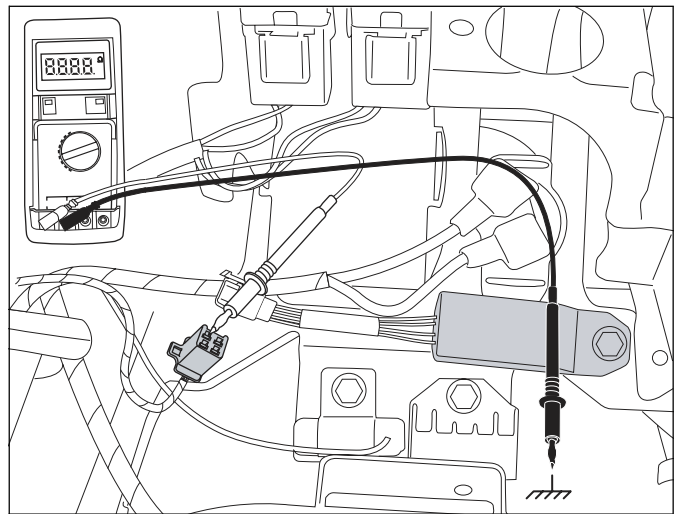

■ Checking the ignition system

Disconnect the ignition unit and take the measurements on the harness side.

- Between the green wire and the ground: 0Ω
 - Between the yellow/black wire and the ground (Primary high voltage coil): $0.2 \Omega \pm 20\%$.
 - Between the green/black wire and the ground (Ignition sensor) : $115 \Omega \pm 20\%$.
 - Between the black wire and the ground, ignition on: 12 V (Battery voltage).
- If the values are correct, replace the ignition module.
 - If the values are incorrect, check:
 - The ignition switch.
 - The harness.
 - The high voltage coil.
- Primary: $0.2 \Omega \pm 20\%$
 Secondary: $5 \Omega \pm 20\%$.
- The suppressor: $5 \text{ k}\Omega \pm 20\%$.
 - The ignition sensor
- Between the green/black wire and the ground:
 $115 \Omega \pm 20\%$.

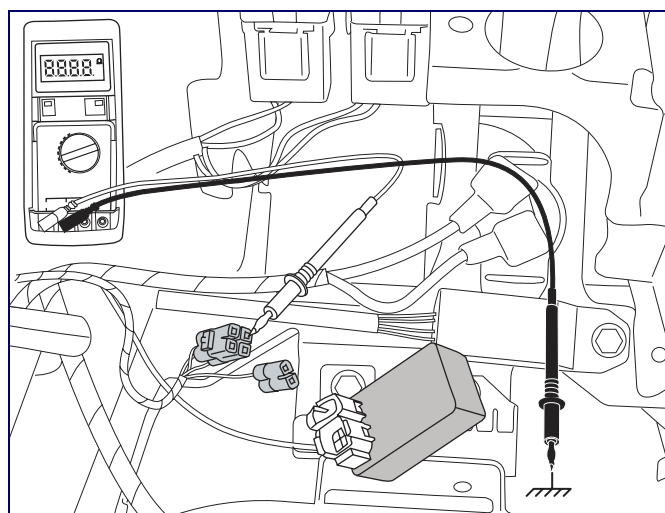

■ Fuel gauge

- Remove the footboard. See: Procedure 7 page 24.
- Disconnect the fuel gauge (1).
- Remove the fuel gauge (4 screw).
- Remove the rubber gasket.

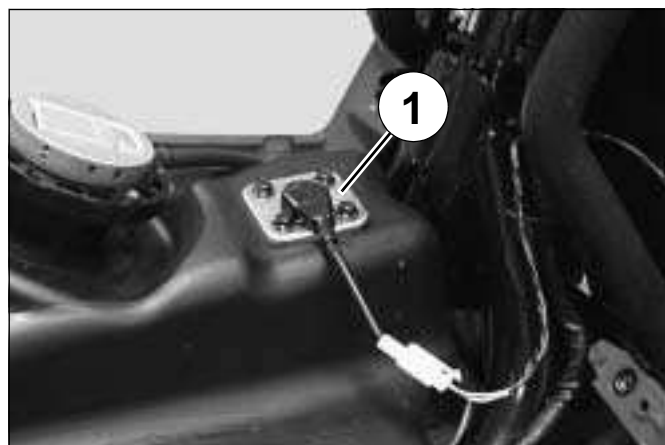

When re-installing, use a new gasket.

Fuel gauge check

- Check the resistance between the terminals depending on the upper and lower positions of the float.
- A. Full fuel tank: $10 \Omega \pm 20\%$
 B. Empty fuel tank: $95 \Omega \pm 20\%$.

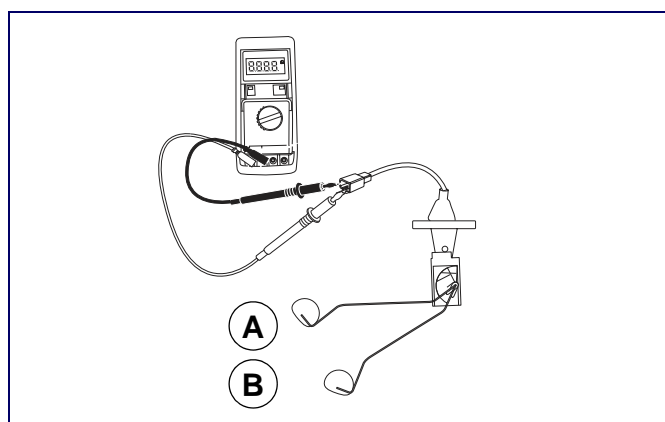

FUEL SYSTEM

■ Removal of the fuel pump

- Remove the storage compartment. See: Procedure 1 page 19.
- Clamp the end of the fuel inlet pipe using a clip ref. 755996 (1).
- Disconnect the 2 fuel pipes (1).
- Disconnect the vacuum hose (2).
- Remove the fuel pump (1 screw).

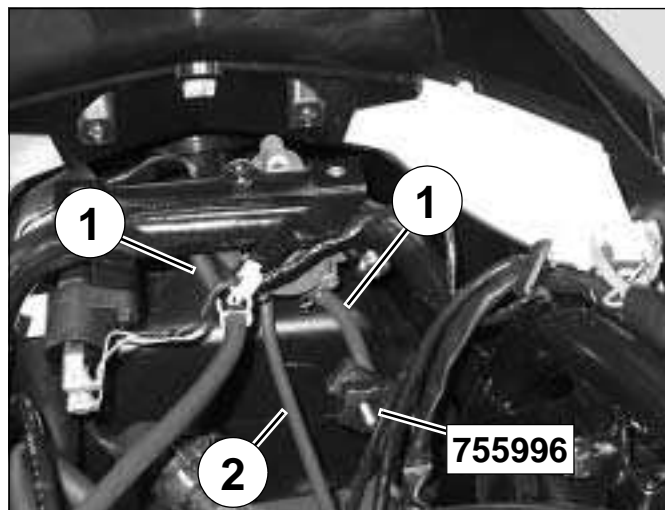

■ Removal of the carburettor

- Remove the storage compartment. See: Procedure 1 page 19.
- Remove the lower fairing by sliding it towards the rear of the vehicle (1 screw).
- Disconnect:
 - The throttle control (1).
 - The fuel inlet pipe (2).
- Disconnect:
 - The carburettor heating resistor (3).
 - The choke (4).
- Remove the carburettor (2 Collars).

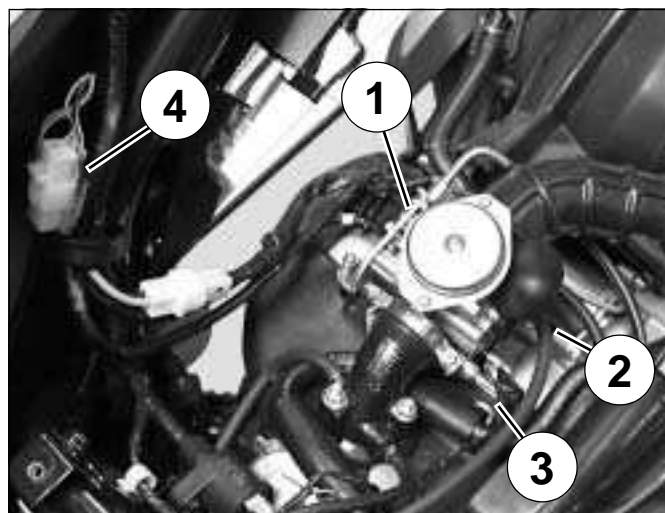

■ Removal of the throttle valve

- Remove the chamber cap (2 screw).
- Remove the spring.
- Remove the needle, valve and membrane assembly.



- Remove the needle stop (2).
- Remove the spring (3).
- Remove the needle (4).

	<p>Check that the membrane is in good condition. The height of the needle is factory set and cannot be modified.</p>
--	---

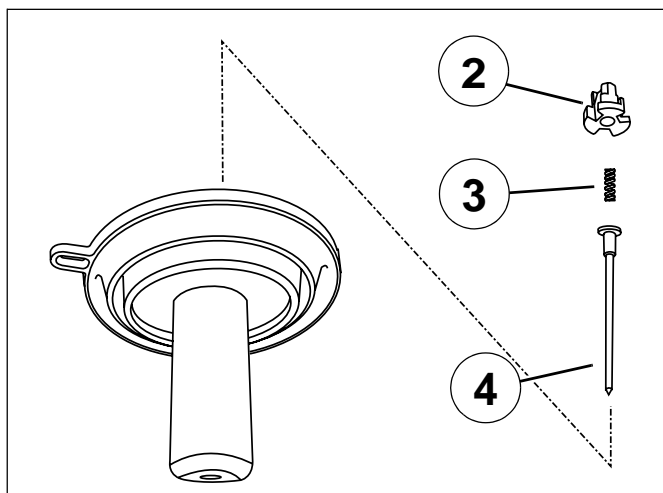

■ Removal of the float, needle valve and jets

- Remove the chamber (4 screw).
- Remove the float chamber and its O-ring.

	<p>Check the condition of the float chamber O-ring.</p>
--	--

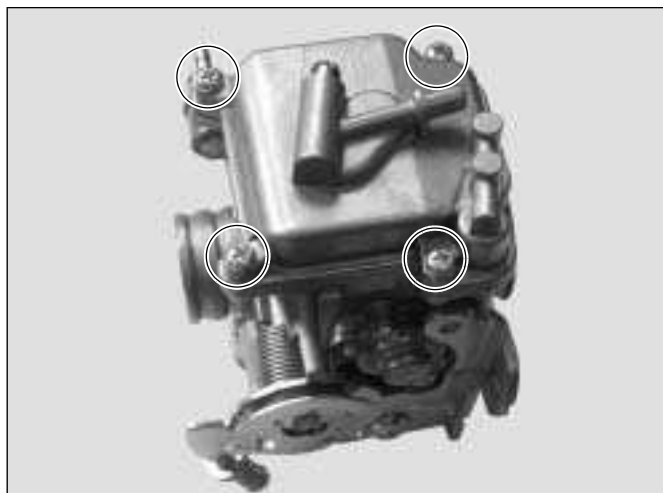

- Loosen the float pin clamping screw (2).
- Remove the float (3), its pin (4) and the needle valve (5).

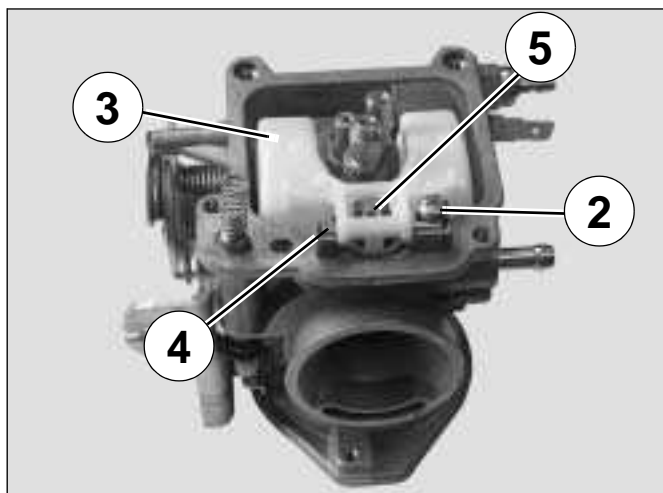

- Remove the idle jet (6).
- Remove the main jet (7).
- Remove the needle well (8).

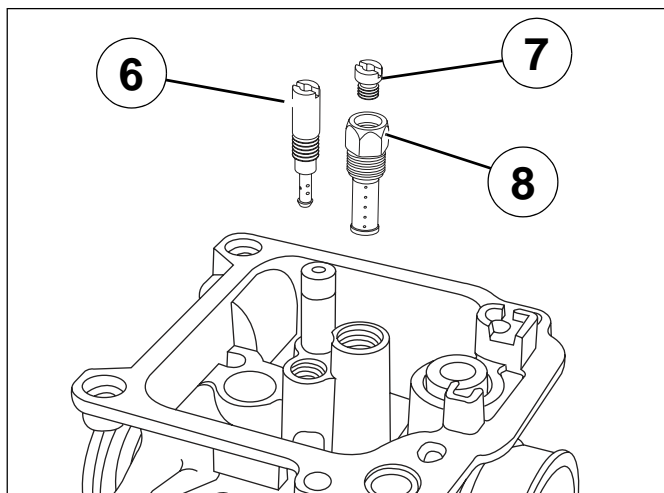

✓ **Check the condition of the needle valve and the needle valve seat (A).
Check the condition of the float chamber O-ring.**

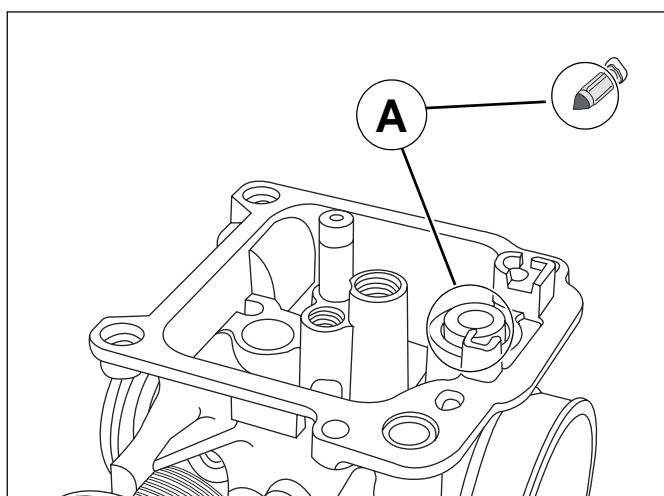

■ **Removal of the mixture screw**

- Turn clockwise the mixture control screw (1) while counting the number of turns until it is screwed home.

✓ **When re-fitting, this operation allows you to put it back to its initial adjustment position.**



■ **Removal of the pick-up pump**

- Remove the 2 screws from the sheathing holder plate.
- Remove the bushing (1) and the protective rubber (2).

✓	<p>Check the condition of the bushing and the rubber protection.</p>
---	---

- Remove the piston (3).

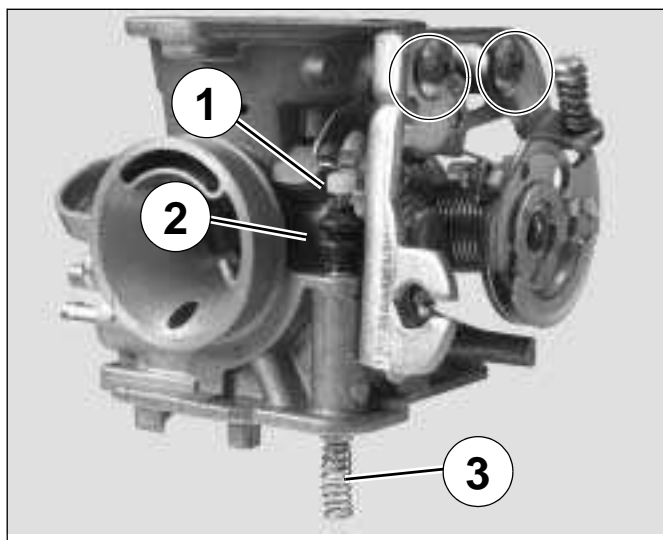

■ **Removal of the pick-up pump suction valve**

- Remove the jet.
- Remove the spring.
- Remove the ball.



■ **Removal of the deceleration enrichment device**

- Remove the 2 bolts that secure the cover.
- Remove the cover.
- Remove the spring.
- Remove the membrane.
- Remove the O ring.

✓	<p>Check that the membrane is in good condition.</p> <p>Check the condition of the O-ring.</p>
---	--

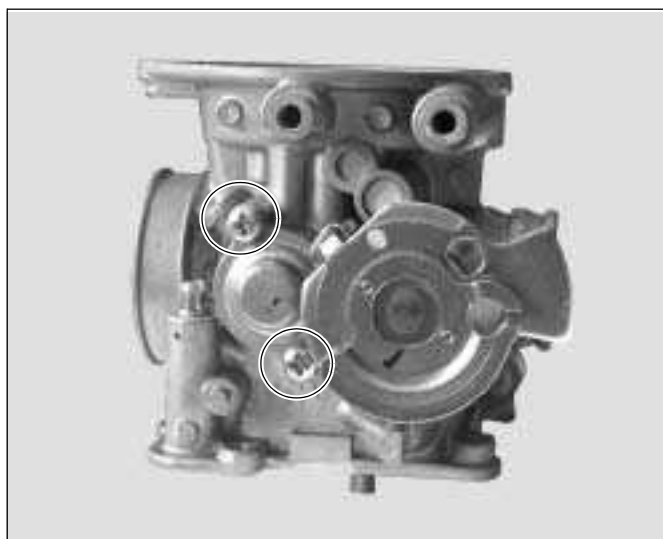

■ **Removal of the carburetor heater**

- Remove the carburator warming resistor (1).
- Remove the heater earthing connection (2).

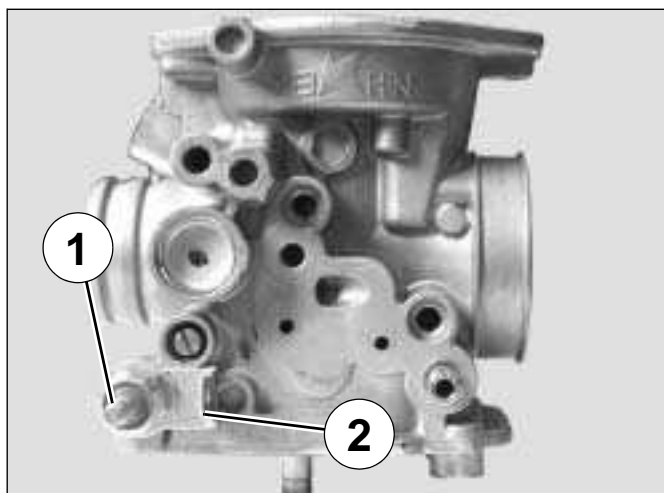

- Clean the carburettor body with Biosane cleanser ref. 754748 or use an ultrasonic cleaning tank.
- Blow into every jet and duct of the carburettor body with compressed air.

✓ **Do not use any metal tool which can damage the ducts of these items.**

- Re-install all the other components and, if necessary, when starting the engine, readjust according to the values indicated on the technical data card.



■ **The carburettor and its components**

1. Choke.
2. Piston.
3. Sump.
4. Float.
5. Jets.
6. Needle valve.
7. Mixture screw.
8. Pick-up pump.
9. Idle screw.
10. Pick-up pump suction valve.
11. Deceleration enrichment device.
12. Carburetor heater.

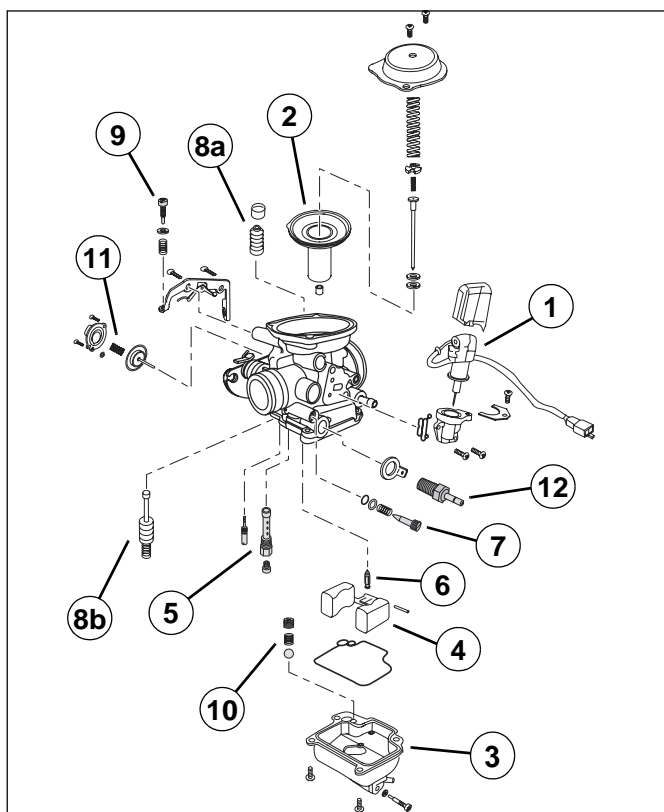

POWER UNIT

■ Removal of the power unit

Note: To remove the cylinder head, remove the power propulsion unit.

For removal of the cylinder head, cylinder and piston, see the workshop manual: 2-valve, 50cc 4-stroke engine.

- Remove the storage compartment. See: Procedure 1. page 19.
- Remove the lower fairing by sliding it towards the rear of the vehicle (1 screw).
- Disconnect:
 - The magneto (1).
 - The starter motor (1).
 - The choke (1).
 - The suppressor (2).
 - The carburettor heater (3).
- Disconnect:
 - The throttle control (4).
 - The fuel inlet pipe (5).
 - The vacuum pressure hose (6) (Pulsair).
 - The vacuum pressure hose (7) (Fuel pump).
 - The pulsair reed valve hose (8).
 - The rear brake control cable.

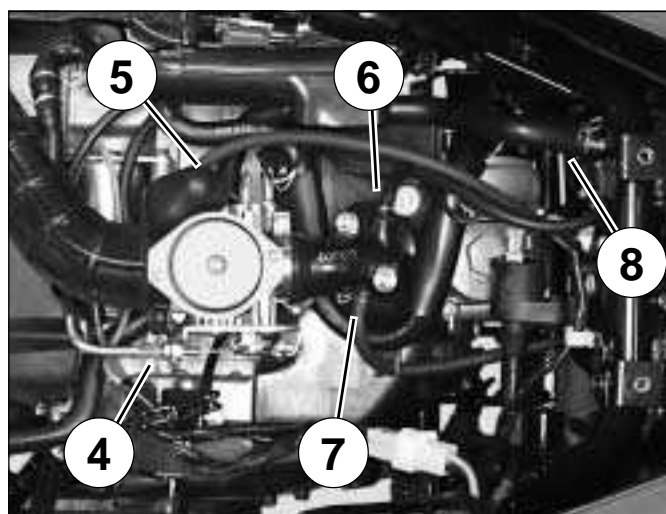
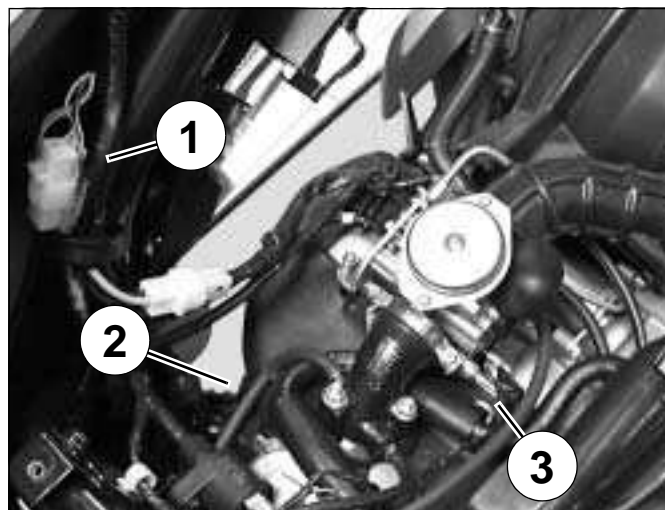

- Suspend the rear of the machine
- Remove the shock absorber upper mount (9).

Tightening torque: 45 Nm.



When re-installing, use a new nut.

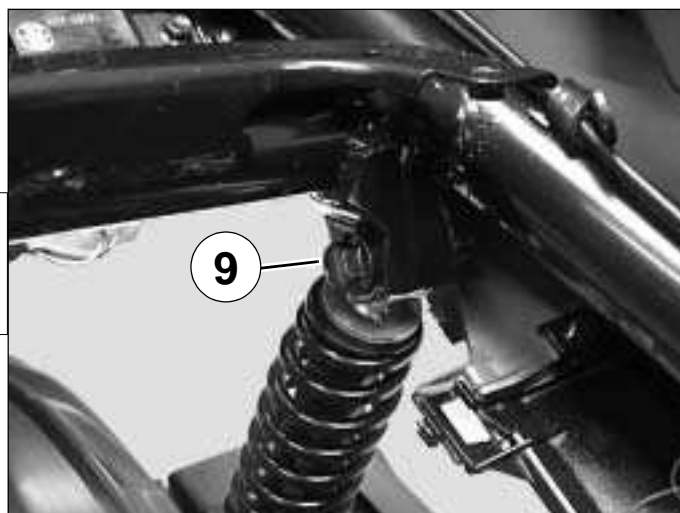

- Remove the linkrod-to-engine connecting pin (10).

Tightening torque: 60 Nm.



When re-installing, use a new nut.

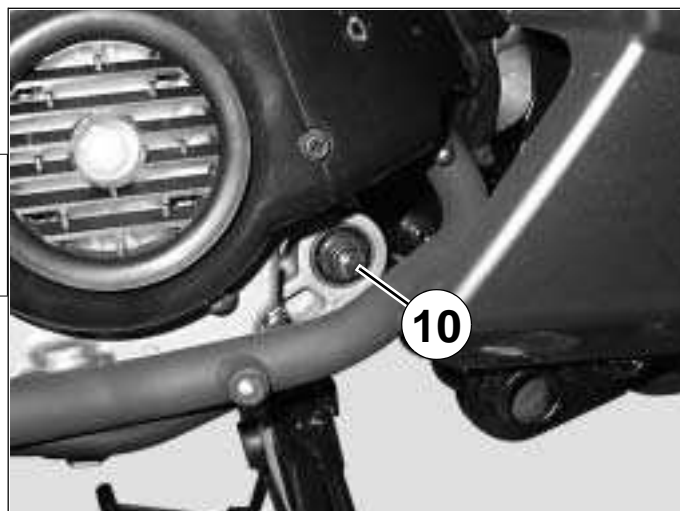

- Remove the power propulsion unit from the frame.
- Remove the covers from the power unit.





P/N. MA0014GB

Peugeot Motorcycles is constantly improving its vehicles. It therefore reserves the right to remove, modify or add any reference mentioned in this manual.

DC/PS/APV 12/2009 (non contractual pictures)

