



[FORWARD](#)

[CONTENTS](#)

[HOW TO USE THIS MANUAL](#)

[MECHANISM ILLUSTRATIONS](#)



DD 50

SERVICE MANUAL

This service manual contains the technical data of each component inspection and repair for the SANYANG DD 50 series scooter. The manual is shown with illustrations and focused on “Service Procedures”, “Operation Key Points”, and “Inspection Adjustment” so that provides technician with service guidelines.

If the style and construction of the scooter, DD 50 series, are different from that of the photos, pictures shown in this manual, the actual vehicle shall prevail. Specifications are subject to change without notice.

**Service Department
Sanyang Industry Co., LTD.**

How to Use This Manual



This service manual describes basic information of different system parts and system inspection & service for Sanyang DD 50 scooters. In addition, please refer to the manual contents in detailed for the model you serviced in inspection and adjustment.

The first chapter covers general information and trouble diagnosis.
The second chapter covers service maintenance information.
The third to the tenth nine chapters covers engine and driving systems.
The tenth to the fourteenth is contained the parts set of assembly body.
The fifteenth chapter is electrical equipment.
The sixteenth chapter is wiring diagram

Please see index of content for quick having the special parts and system information.

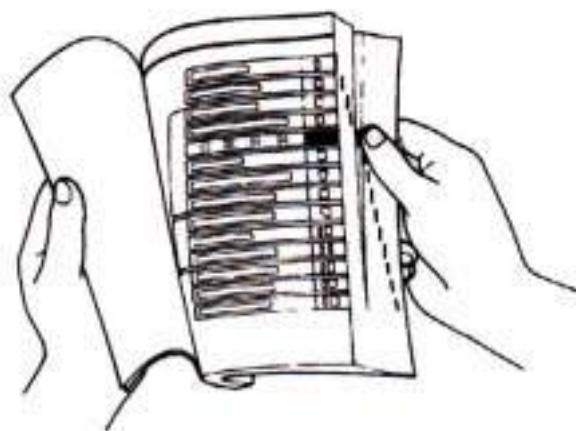

All information, illustration, directions and specifications included in this manual are current as at the time of publication. Sanyang reserves the rights to make changes at any time without prior notice and without incurring any obligation whatever. Without written consent by SANYANG can not copy any part of this manual.

There are 4 buttons, “[Forward](#),” “[How to use this manual](#),” “[Mechanism Illustrations](#),” and “[Contents](#)” on the CD-R version, and can be access to these items by click the mouse.

If user wants to look for the content of each chapter, selecting the words of each chapter on the main contents can reach to each chapter. There are two buttons, Back to homepage and Main contents, onto the top line of first page of the each chapter. Thus, if the user needs to check other chapters, he can click the top buttons to back the homepage or main contents. The content of each chapter can be selected too. Therefore, when needs to checking the content inside of the chapter, click the content words of the chapter so that can back to the initial section of the content. In addition, there is a “[This chapter contents](#)” button at the top line of each page so that clicking the button can back to the contents of this chapter.

Page	Content	Index
1-1 ~ 1-16	GENERAL INFORMATION	1
2-1 ~ 2-14	SERVICE MAINTENANCE INFORMATION	2
3-1 ~ 3-6	LUBRICATION SYSTEM	3
4-1 ~ 4-6	ENGINE REMOVAL	4
5-1 ~ 5-8	CYLINDER HEAD/CYLINDER/PISTON	5
6-1 ~ 6-4	ALTERNATOR	6
7-1 ~ 7-14	“V” TYPE BELT DRIVING SYSTEM/KICK-STARTER	7
8-1 ~ 8-6	FINAL DRIVING MECHANISM	8
9-1 ~ 9-6	CRANKCASE/CRANKSHAFT	9
10-1 ~ 10-10	FUEL SYSTEM	10
11-1 ~ 11-12	BRAKE SYSTEM	11
12-1 ~ 12-14	BODY COVER	12
13-1 ~ 13-10	STEERING/FRONT WHEEL/SUSPENSION	13
14-1 ~ 14-4	REAR WHEEL/SUSPENSION	14
15-1 ~ 15-18	ELECTRICAL EQUIPMENT	15
16-1 ~ 16-2	ELECTRICAL DIAGRAM	16

MODEL ILLUSTRATION

FT05V

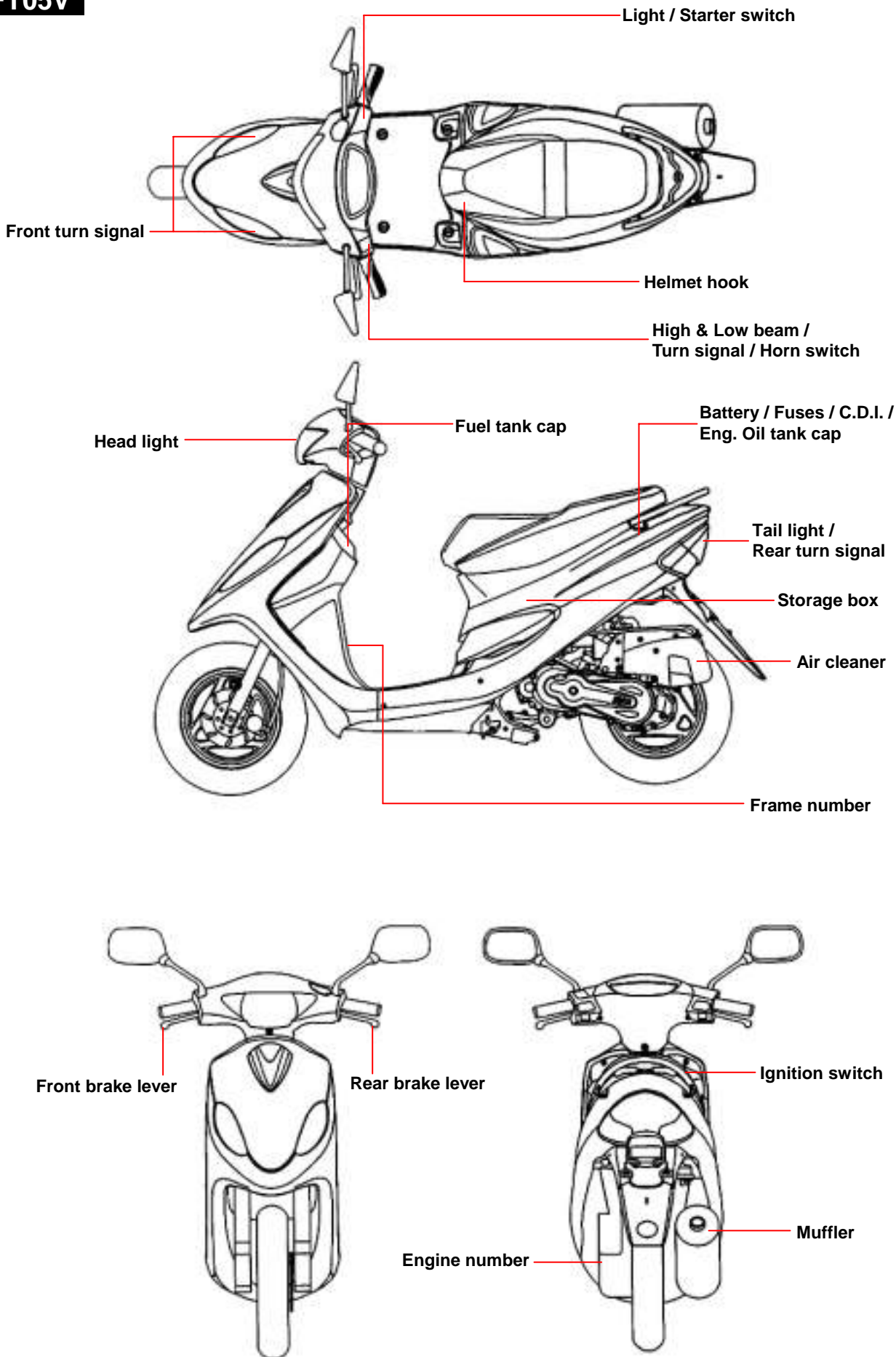

FT05T



FT05U



FT05W

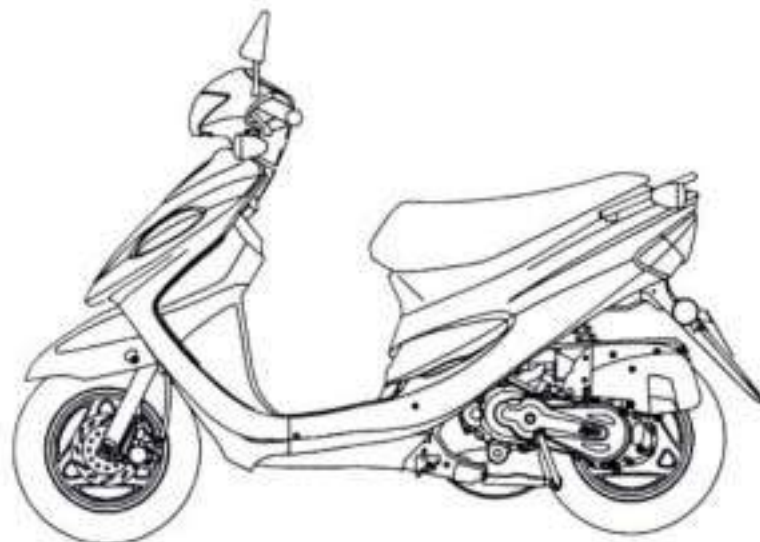

Symbols and Marks 1-1	Torque values1-6
General Safety 1-2	Cables and Harness Routing1-8
Service Precautions 1-3	Troubleshooting1-11
Specifications 1-5	Lubrication Points1-15

Symbols and Marks

Symbols and marks are used in this manual to indicate what and where the special service are needed, in case supplemental information is procedures needed for these symbols and marks, explanations will be added to the text instead of using the symbols or marks.

	Warning	Means that serious injury or even death may result if procedures are not followed.
	Caution	Means that equipment damages may result if procedures are not followed.
	Engine oil	Limits to use SAE 20 JASO FC class oil. Warranty will not cover the damage that caused by not apply with the limited engine oil. (Recommended oil: MAX-2 serial oils)
	Grease	King Mate G-3 is recommended.
	Gear oil	King Mate gear oil serials are recommended. (Bramax HYPOID GEAR OIL # 140)
	Locking sealant	Apply sealant, medium strength sealant should be used unless otherwise specified.
	Oil seal	Apply with lubricant.
	Renew	Replace with a new part before installation.
	Brake fluid	Use recommended brake fluid DOT3 or WELLRUN brake fluid.
	Special tools	Special tools.
	Correct	Meaning correct installation.
	Wrong	Meaning wrong installation.
	Indication	Indication of components.
	Directions	Indicates position and operation directions.
		Components assembly directions each other.
		Indicates where the bolt installation direction, --- means that bolt cross through the component (invisibility).

1. GENERAL INFORMATION

General Safety

Carbon monoxide

If you must run your engine, ensure the place is well ventilated. Never run your engine in a closed area. Run your engine in an open area, if you have to run your engine in a closed area, be sure to use an extractor.

Caution

Exhaust contains toxic gas which may cause one to lose consciousness and even result in death.

Gasoline

Gasoline is a low ignition point and explosive material. Work in a well-ventilated place, no flame or spark should be allowed in the work place or where gasoline is being stored.

Caution

Gasoline is highly flammable, and may explode under some conditions, keep it away from children.

Used engine oil

Caution

Prolonged contact with used engine oil (or transmission oil) may cause skin cancer although it might not be verified.

We recommend that you wash your hands with soap and water right after contacting. Keep the used oil beyond reach of children.

Hot components

Caution

Components of the engine and exhaust system can become extremely hot after engine running. They remain very hot even after the engine has been stopped for some time. When performing service work on these parts, wear insulated gloves and wait until cooling off.

Battery

Caution

- Battery emits explosive gases; flame is strictly prohibited. Keep the place well ventilated when charging the battery.
- Battery contains sulfuric acid (electrolyte) which can cause serious burns so be careful do not be spray on your eyes or skin. If you get battery acid on your skin, flush it off immediately with water. If you get battery acid in your eyes, flush it off immediately with water and then go to hospital to see an ophthalmologist.
- If you swallow it by mistake, drink a lot of water or milk, and take some laxative such as castor oil or vegetable oil and then go to see a doctor.
- Keep electrolyte beyond reach of children.

Brake shoe

Do not use an air hose or a dry brush to clean components of the brake system, use a vacuum cleaner or the equivalent to avoid dust flying.

Caution

Inhaling dust may cause disorders and cancer of the breathing system.

Brake fluid

Caution

Spilling brake fluid on painted, plastic, or rubber parts may cause damage to the parts. Place a clean towel on the above-mentioned parts for protection when servicing the brake system. Keep the brake fluid beyond reach of children.

Service Precautions

- Always use with Sanyang genuine parts and recommended oils. Using non-designed parts for Sanyang motorcycle may damage the motorcycle.
- Special tools are designed for remove and install of components without damaging the parts being worked on. Using wrong tools may result in parts damaged.
- When servicing this motorcycle, use only metric tools. Metric bolts, nuts, and screws are not interchangeable with the English system, using wrong tools and fasteners may damage this vehicle.
- Clean the outside of the parts or the cover before removing it from the motorcycle. Otherwise, dirt and deposit accumulated on the part's surface may fall into the engine, chassis, or brake system to cause a damage.
- Wash and clean parts with high ignition point solvent, and blow dry with compressed air. Pay special attention to O-rings or oil seals because most cleaning agents have an adverse effect on them.

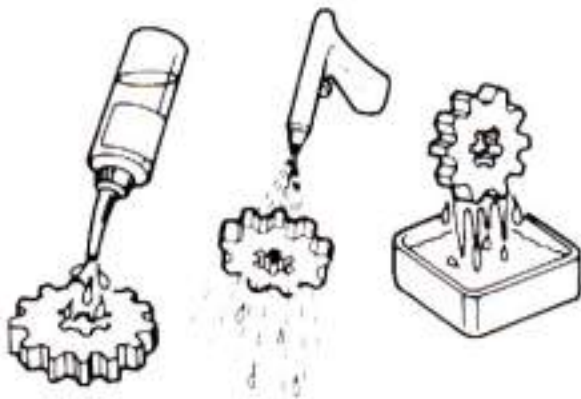

- Never bend or twist a control cable to prevent stiff control and premature worn out.



- Rubber parts may become deteriorated when old, and prone to be damaged by solvent and oil. Check these parts before installation to make sure that they are in good condition, replace if necessary.
- When loosening a component which has different sized fasteners, operate with a diagonal pattern and work from inside out. Loosen the small fasteners first. If the bigger ones are loosen first, small fasteners may receive too much stress.
- Store complex components such as transmission parts in the proper assemble order and tie them together with a wire for ease of installation later.

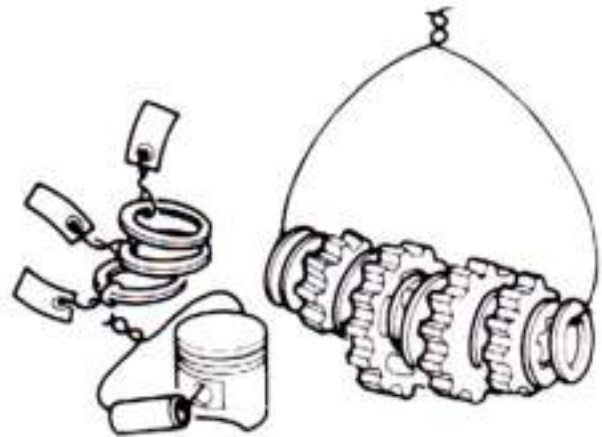

- Note the reassemble position of the important components before disassembling them to ensure they will be reassembled in correct dimensions (depth, distance or position).
- Components not to be reused should be replaced when disassembled including gaskets metal seal rings, O-rings, oil seals, snap rings, and split pins.



⚠ Caution

In addition to damaging paint finish, brake oil can also damage the structural integration of plastic or rubber parts.

1. GENERAL INFORMATION

- The length of bolts and screws for assemblies, cover plates or boxes is different from one another, be sure they are correctly installed. In case of confusion, Insert the bolt into the hole to compare its length with other bolts, if its length out side the hole is the same with other bolts, it is a correct bolt. Bolts for the same assembly should have the same length.

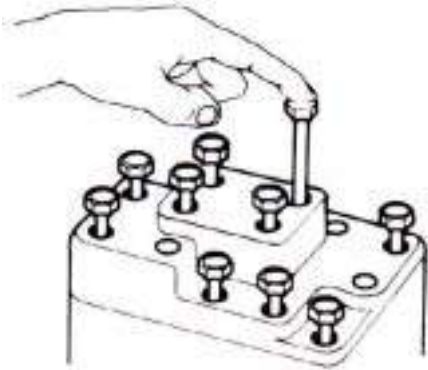

- Tighten assemblies with different dimension fasteners as follows: Tighten all the fasteners with fingers, then tighten the big ones with special tool first diagonally from inside toward outside, important components should be tightened 2 to 3 times with appropriate increments to avoid warp unless otherwise indicated. Bolts and fasteners should be kept clean and dry. Do not apply oil to the threads.
- When oil seal is installed, fill the groove with grease, install the oil seal with the name of the manufacturer facing outside, check the shaft on which the oil seal is to be installed for smoothness and for burrs that may damage the oil seal.

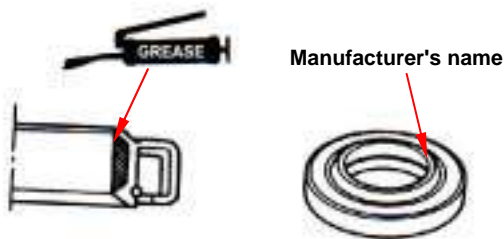

- Remove residues of the old gasket or sealant before reinstallation, grind with a grindstone if the contact surface has any damage.



- The ends of rubber hoses (for fuel, vacuum, or coolant) should be pushed as far as they can go to their connections so that there is enough room below the enlarged ends for tightening the clamps.

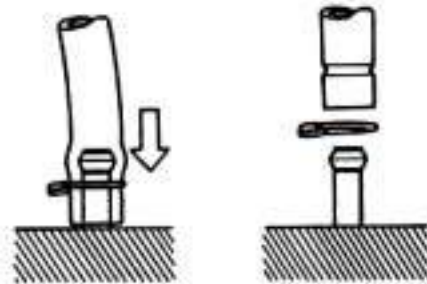

- Rubber and plastic boots should be properly reinstalled to the original correct positions as designed.

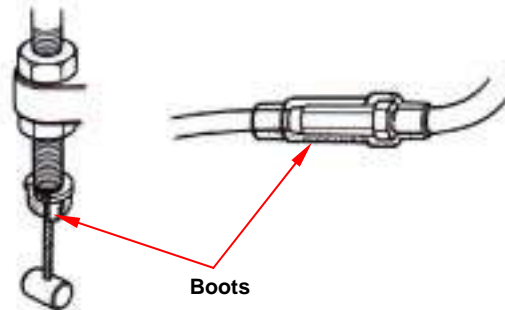

- The tool should be pressed against two (inner and outer) bearing races when removing a ball bearing. Damage may result if the tool is pressed against only one race (either inner race or outer race). In this case, the bearing should be replaced. To avoid damaging the bearing, use equal force on both races.

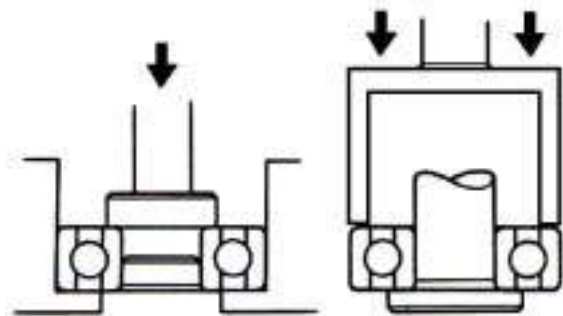

Both of these examples can result in bearing damage.

- Lubricate the rotation face as assembling. Check if positions and operation for installed parts is in correct and properly.



Specifications

Make		SANYANG		MODEL		FT05 Series		
DIMENSION	Overall Length	1660 mm		Suspension System	Front	TELESCOPIC		
	Overall Width	630 mm			Rear	UNIT SWING		
	Overall Height	1020 mm		Tire Specifications	Front	3.00 - 10 42J(T/L)		
	Wheel Base	1155 mm			Rear	3.00 - 10 42J(T/L)		
WEIGHT	Curb Weight	Front	32 kg	Brake System	Front	DISK (160mm)		
		Rear	48 kg			DRUM (110mm)		
		Total	80 kg		Rear	DRUM (95mm)		
	Passengers/Weight		Two /110 kg		PERFORMANCE	Max. Speed		48 km/hr Below
	Total Weight	Front	54 kg	Climb Ability		20° Below		
		Rear	136 kg	Primary Reduction		BELT		
		Total	190 kg	Secondary Reduction		GEAR		
Type		Gasoline		Clutch		Centrifugal, dry type		
Installation and arrangement		Vertical, below center, incline		Transmission		C.V.T.		
Fuel Used		Unleaded(92/95)		Speedometer		0 ~ 90 km/hr		
Cycle/Cooling		2-stroke/forced air cooled		Horn		80 ~ 112 dB/A		
ENGINE	Cylinder	Bore	39 mm	Muffler		Expansion & Pulse Type		
		Stroke	41.4 mm	Exhaust Pipe Position and Direction		Right side, and Backward		
		Number/Arrangement	Single Cylinder	Lubrication System		Separated-lubrication		
	Displacement		49.4 cc		Exhaust Concentration	Solid Particulate		15 % ↓
Compression Ratio		7.1 : 1		CO		3.5 % ↓		
Max. HP		2.7 kw / 6250 rpm		HC		Below 4000 ppm		
Max. Torque		4.41 Nm / 5000 rpm		E.E.C.		Below 2g / test		
Ignition		C.D.I.		P.C.V.		X		
Starting System		Electrical & kick		Catalytic reaction control system				

1. GENERAL INFORMATION

Torque values

Standard Torque Values for Reference

Type	Torque value	Type	Torque value
5 mm Bolt, nut	0.45 - 0.6 kg-m	5 mm Bolt	0.35 - 0.5 kg-m
6 mm Bolt, nut	0.8 - 1.2 kg-m	6 mm Bolt, SH nut	0.7 - 1.1 kg-m
8 mm Bolt, nut	1.8 - 2.5 kg-m	6 mm Flange bolt, nut	1.0 - 1.4 kg-m
10 mm Bolt, nut	3.0 - 4.0 kg-m	8 mm Flange bolt, nut	2.4 - 3.0 kg-m
12 mm Bolt, nut	5.0 - 6.0 kg-m	10 mm Flange bolt, nut	3.5 - 4.5 kg-m

The torque values listed in below table are for more important tighten torque values. Please see above standard values for not listed in the table.

Engine

Item	Q'ty	Thread Dia. (mm)	Torque Value (Kgf-m)	Remarks
Cylinder head bolt	4	6	1.0	When engine cooled
Spark plug	1	14	1.4	
Flywheel nut	1	10	3.8	
Sliding driving disc nut	1	10	3.8	
Sliding driving disc nut	1	28	5.5	
Clutch outer cover nut	1	10	3.8	
Drain bolts	1	8	1.3	
Crankcase bolts	6	6	1.0	

Frame

Item	Q'ty	Thread Dia. (mm)	Torque Value (Kgf-m)	Remarks
Bolt for engine suspension	1	10	5.0	
Bolt for engine suspension bracket	1	12	6.0	
Upper bolt for rear shock absorber	1	10	4.0	
Lower bolt for rear shock absorber	1	8	2.7	
Mounting screws for exhaust pipe connection	2	6	1.2	
Nut for exhaust	2	8	3.3	
Brake hose bolts	2	10	3.5	
Brake caliper mounting bolts	2	8	3.1	
Brake cushion guide bolts	2	6	1.8	
Brake cushion guide bolts cap	2	6	1.0	
Brake drain valve	1	6	0.6	
Rear brake arm bolts	1	5	0.55	
Tightening nut for steering rod	1	25.4	7.0	
Front shaft nut	1	12	6.0	
Mounting bolt for handle	1	10	5.0	
Mounting nut for front hub	4	8	2.5	
Mounting bolt for front brake disc	3	8	4.5	
Rear shaft nut	1	14	11.0	
Nut for rear hub	4	8	2.5	

1. GENERAL INFORMATION

Cables and Harness Routing

Note the following when routing cables and wire harnesses:

- A loose wire, cable or harness may cause safety hazard. After clamping, check each wire to make sure it is secured.
- Do not squeeze wires against the weld or its clamp.
- Secure wires and wire harnesses to the frame with respective wire bands at the designated locations. Tighten the bands so that only the insulated surfaces contact the wires or wire harnesses.
- Route harnesses so that they neither pull too tight nor have excessive slack.
- Protect wires or wire harnesses with electrical tape or tube if they contact a sharp edge or corner.
- Route wire harnesses to avoid sharp edges or corners.
- Avoid the projected ends of bolts and screws.
- Keep wire harnesses far away from the exhaust pipes and other hot parts.
- Be sure grommets are seated in their groves properly.
- After clamping, check each harness to be certain that it is not interfered with any moving or sliding parts.
- After routing, check that the wire harnesses are not twisted or kink.
- Wire harnesses routed along the handlebar should not be pulled too tight or have excessive slack, be rubbed against or interfere with adjacent or surrounding parts in all steering positions.
- Thoroughly clean the surface where tape is to be applied.
- Wrap electrical tape around the damaged parts or replace them.

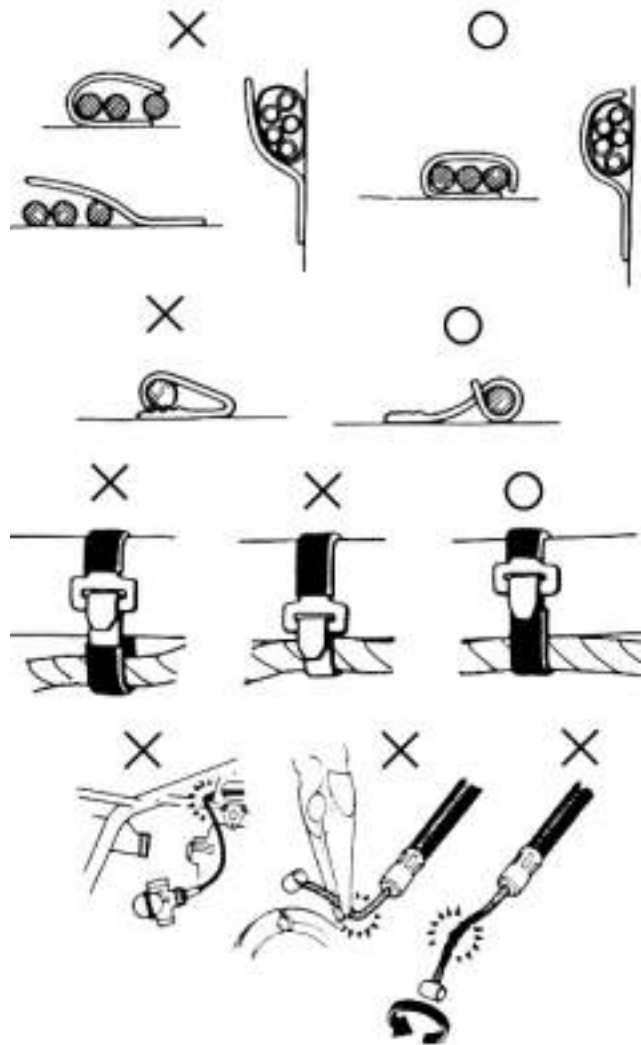

O : Correct

X : Wrong

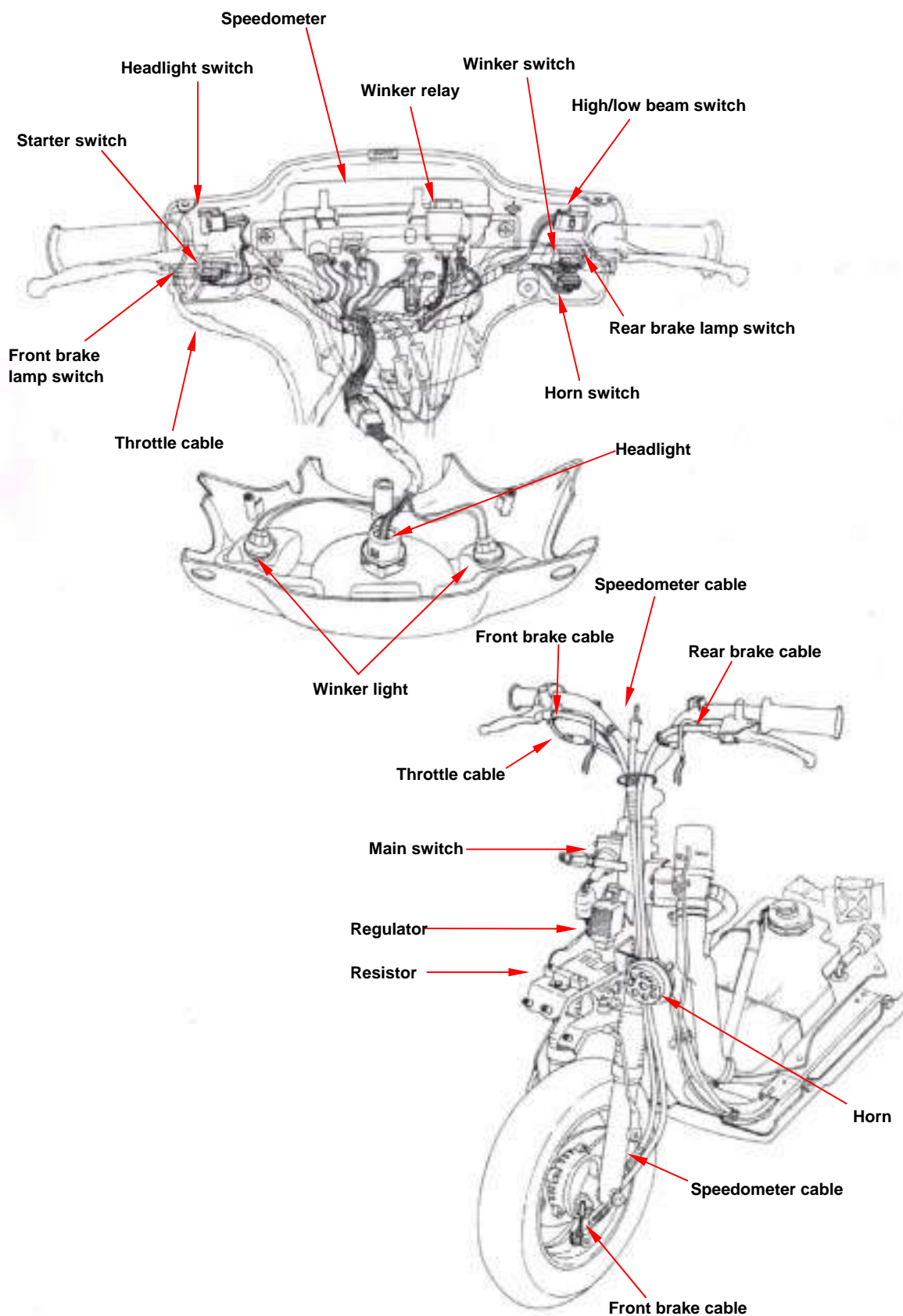

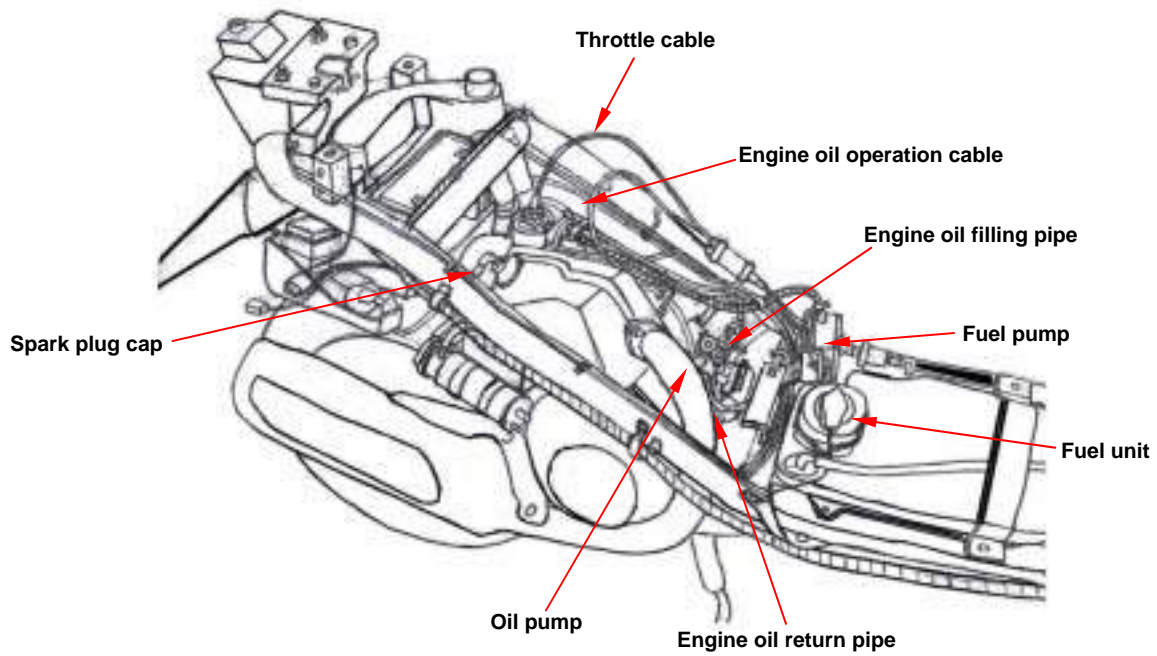
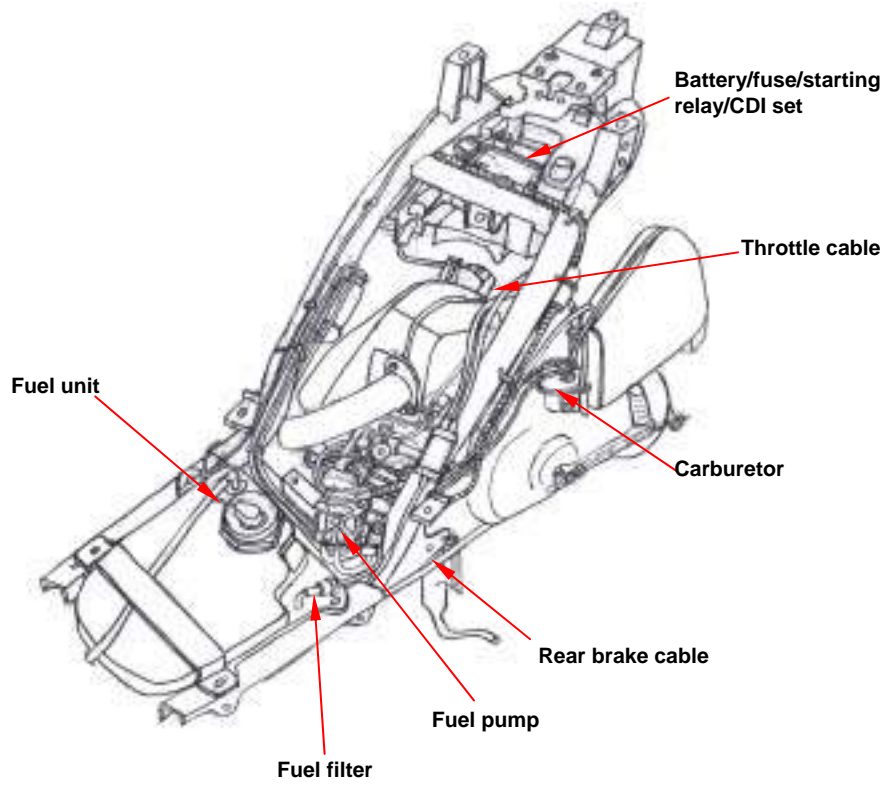



Troubleshooting

A. Engine hard to start or can not be started

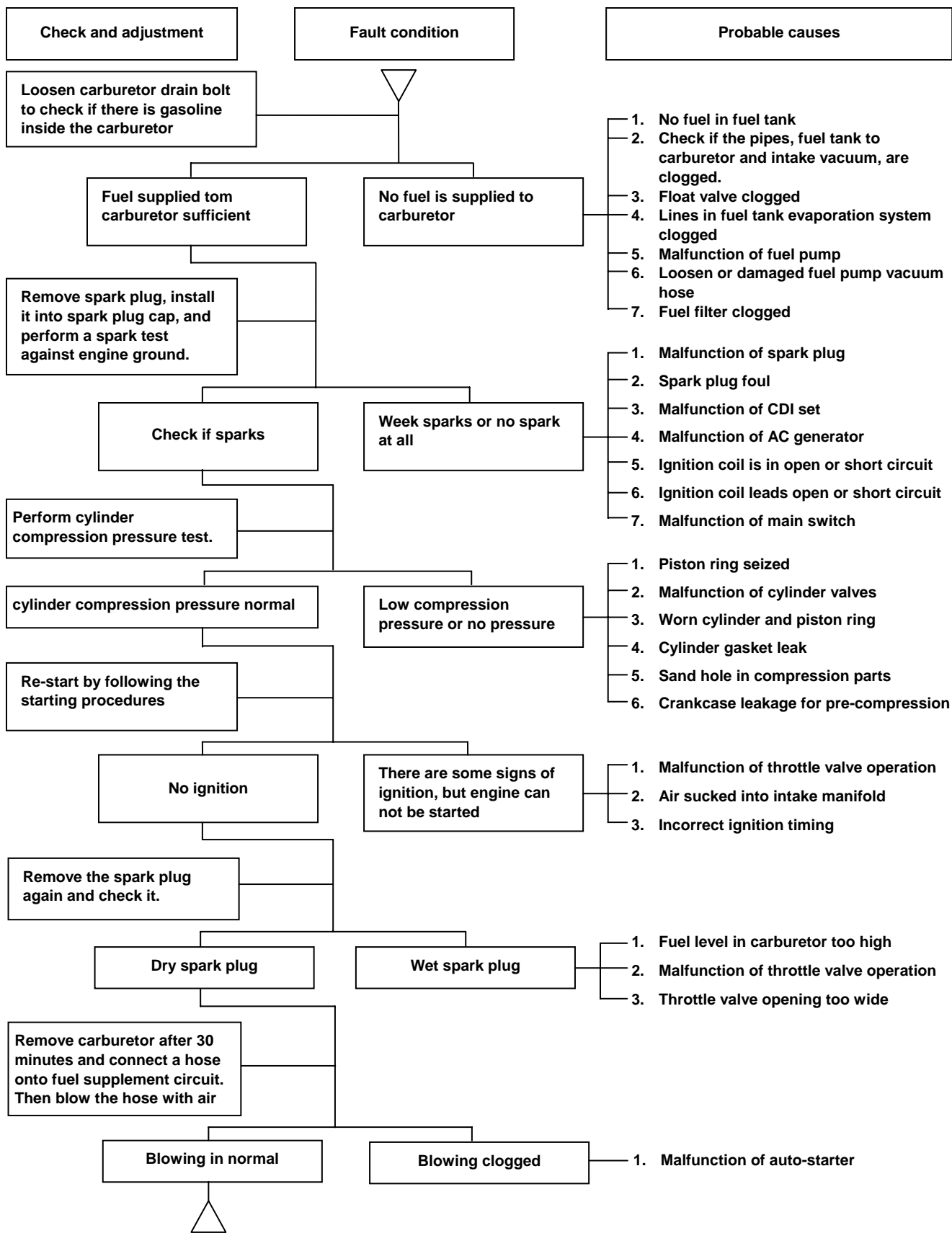

1. GENERAL INFORMATION

B. Engine run sluggish (Speed does not pick up, lack of power)

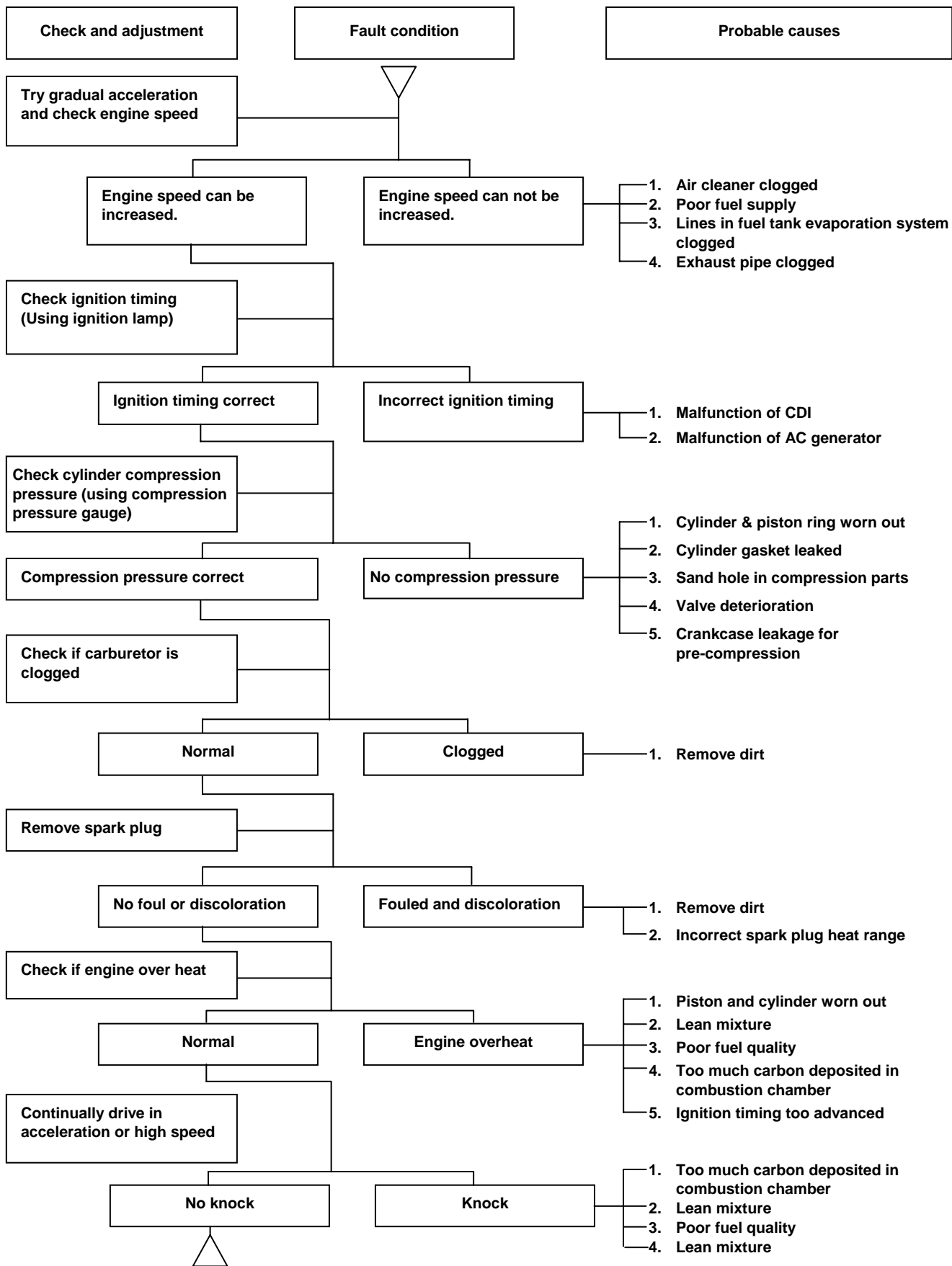

C. Engine runs sluggish (especially in low speed and idling)

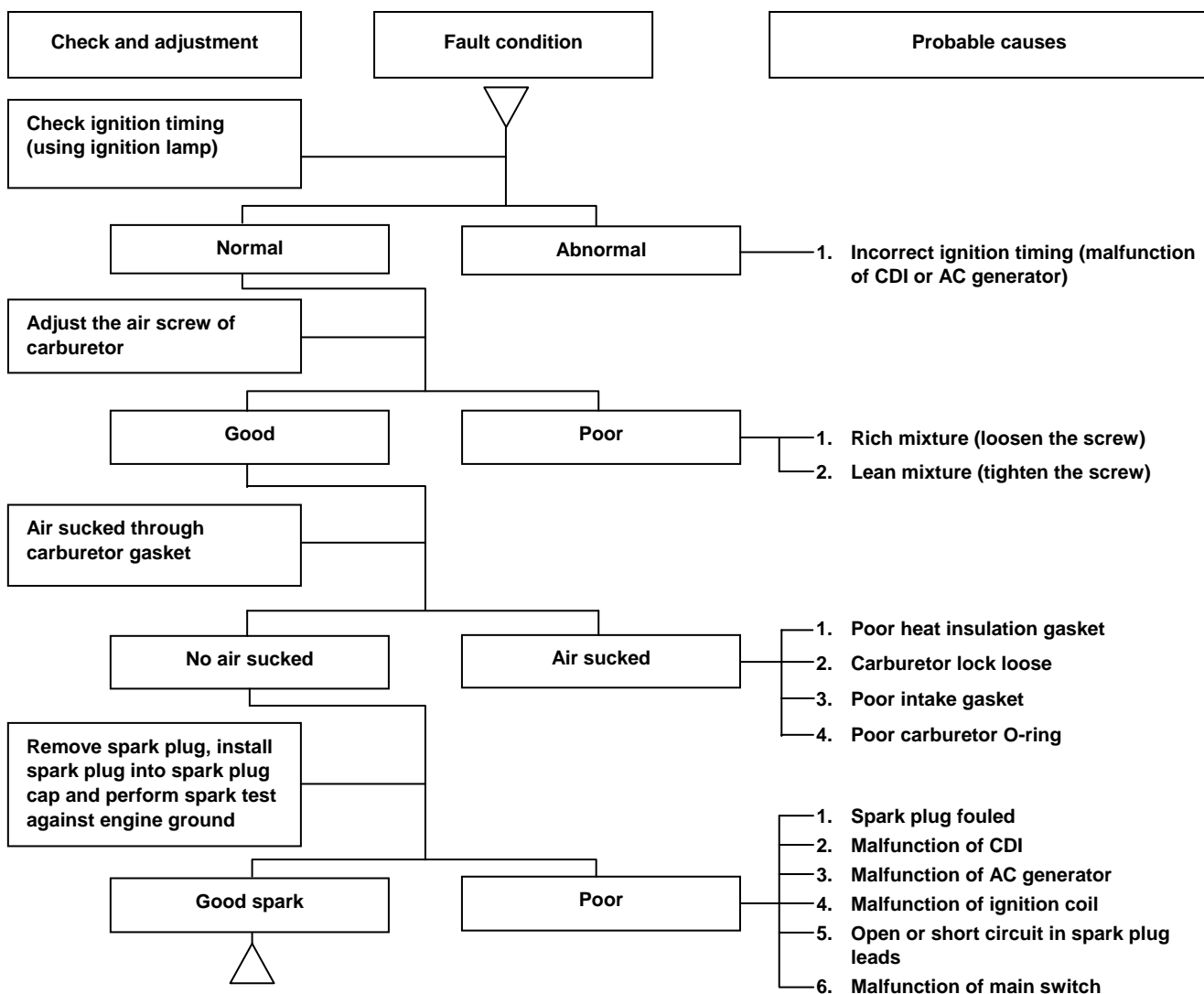

D. Engine runs sluggish (High speed)

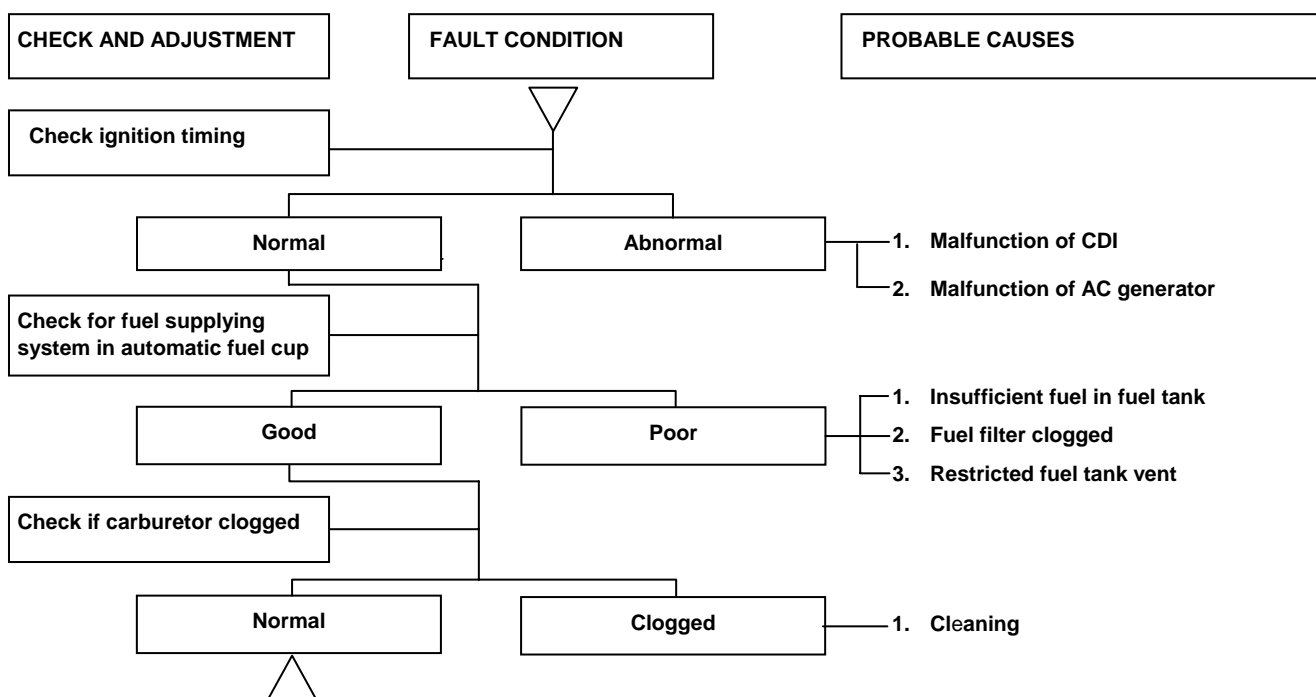

1. GENERAL INFORMATION

E. CLUTCH, DRIVING AND DRIVING PULLEY

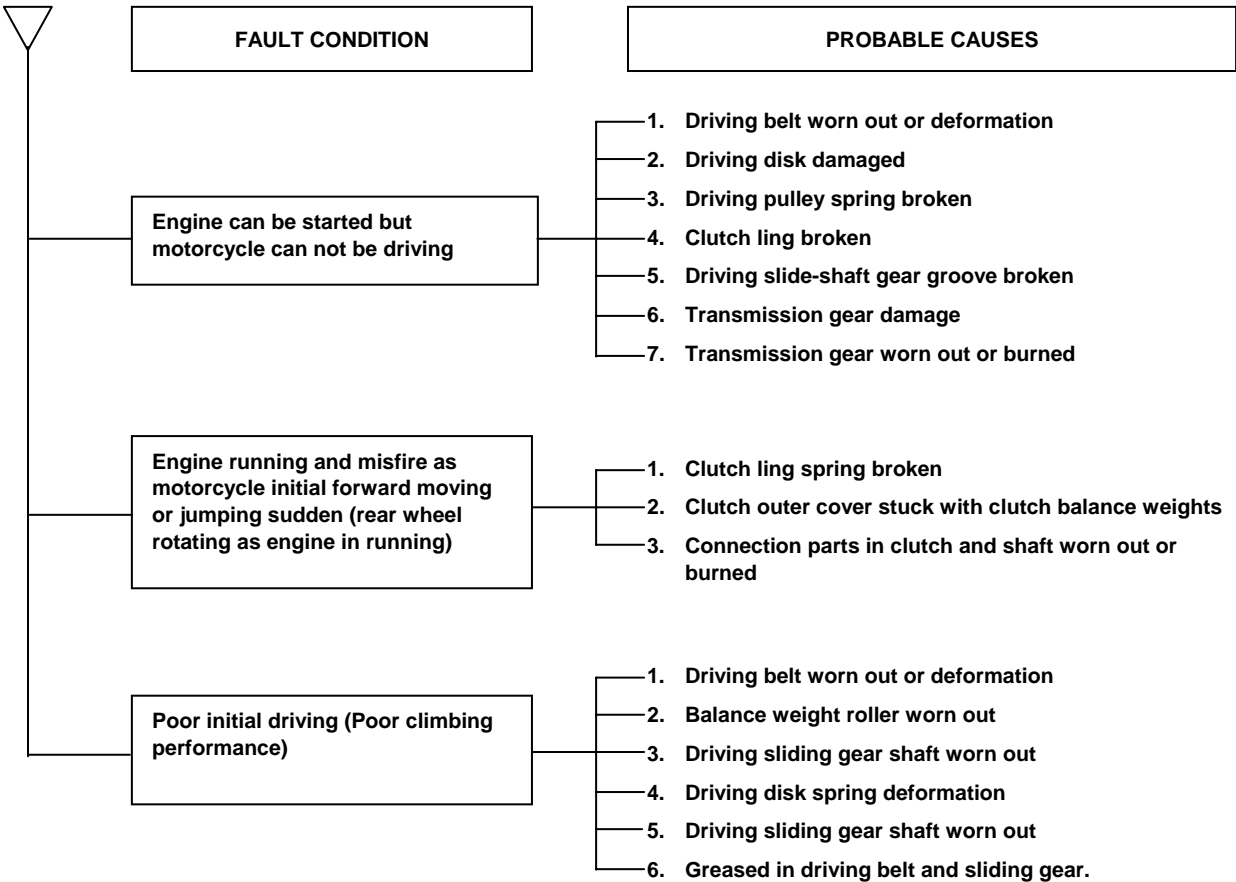

Lubrication Points

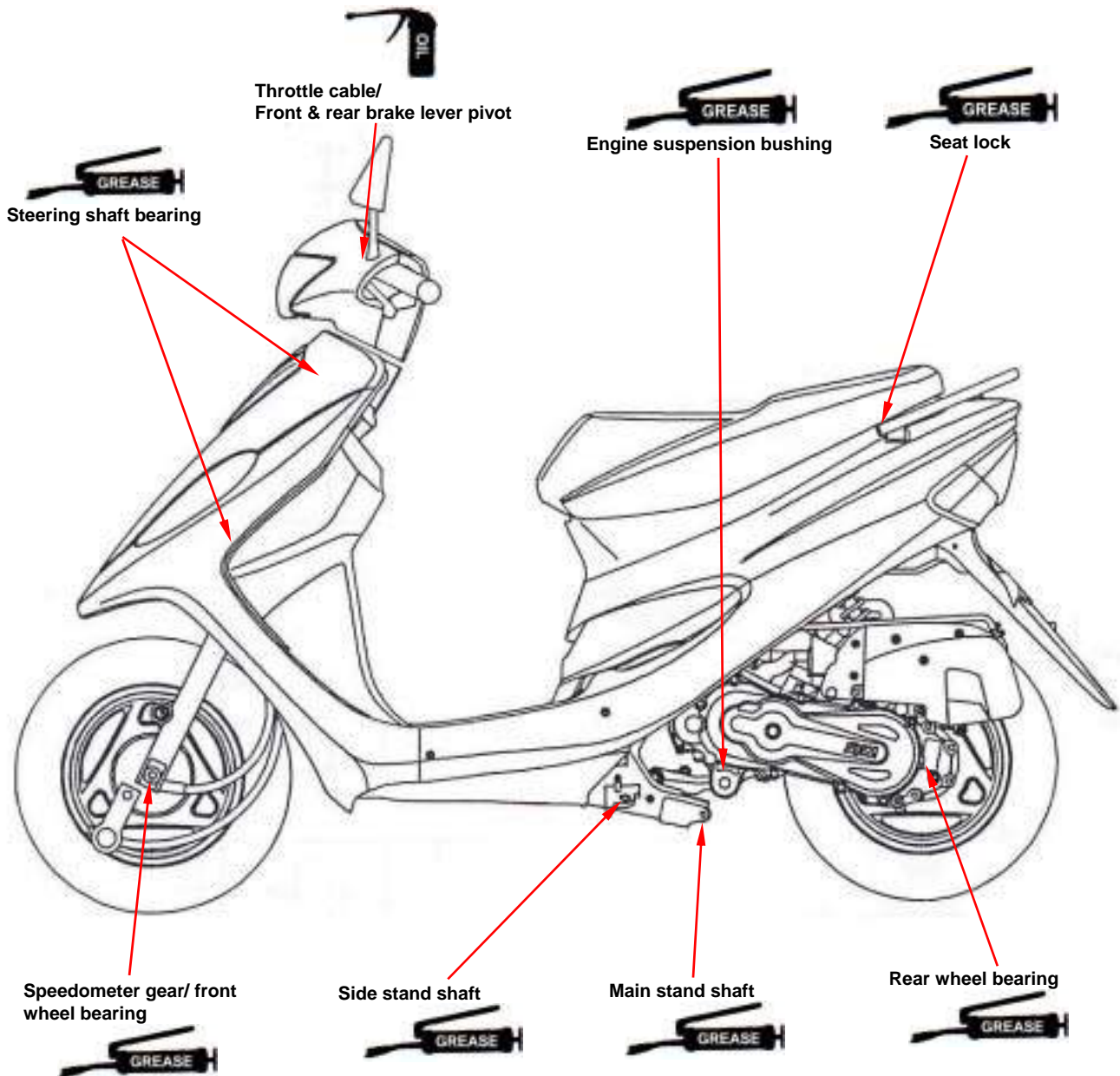

1. GENERAL INFORMATION

Note:

General Information.....	2-1	Suspension.....	2-10
Periodical Maintenance Schedule...	2-2	Transmission Oil.....	2-11
Air Cleaner	2-3	Spark Plug	2-11
Fuel Lines.....	2-3	Control Cable Lubrication	2-12
Fuel Filter	2-4	Driver Belt.....	2-12
Engine Oil Line	2-4	Ignition Timing	2-12
Oil Pump Control Cable	2-5	Throttle Valve Operation.....	2-12
Tire.....	2-6	Carburetor Idle Speed Adjustment	2-13
Battery	2-6	Carbon Removing For Exhaust Pipe & Muffler	2-13
Rear Brake Free Play: (Drum Brake Type)	2-7	Cylinder Compression Pressure Test	
Brake System Hose: (Front Disc Brake Type).....	2-8		2-13
Steering System.....	2-10	Headlight Adjustment	2-14

General Information

Specification

Tire dimension	Front: 3.00-10 42J Rear: 3.00-10 42J	
Tire pressure at cold	Only rider	Front: 1.5kg/cm ² Rear: 2.25 kg/cm ²
Front brake lever free play	10~20 mm	
Rear brake lever free play	10~20 mm	
Transmission oil	Recommendation	Type: HYPOID GEAR OIL Oil: SAE #140 Quantity: 0.1 L
Spark plug	Recommendation	Type: NGK BR8HSA Plug gap: 0.6-0.7mm
Driving belt width	Standard 18.0mm Allowable limit: replace it if below 16.5mm	
Ignition timing F mark	17°, BTDC/1500 rpm	
Acceleration operation	2~6 mm	
Idle speed	2000±100 rpm	
Cylinder compression pressure	7±1 kgf/cm ²	

2. SERVICE MAINTENANCE INFORMATION



Periodical Maintenance Schedule

Check item	Maintenance kilometer	300KM	Every 1000KM	Every 3000KM	Every 6000KM	Every 12000KM	Reference	
	Maintenance interval	New	1 month	3 month	6 month	1 year		
1. Air cleaner		I		C		R		
2. Fuel filter					C			
3. Engine oil filter cleaning		C			C			
4. Oil pump linkage operation check		I		I				
5. Tire pressure		I	I					
6. Battery inspection		I	I					
7. Brake & free play check		I	I					
8. Steering handle check		I			I			
9. Cushion operation check		I			I			
10. Every screw tightening check		I	I					
11. Gear oil check for leaking		I	I					
12. Spark plug check or change		I		R				
13. Gear oil change		R	Replacement for every 5000km					
14. Frame lubrication					L			
15. Exhaust pipe		I	I					
16. Carburetor		I	I					
17. Driving belt check						I		
18. Ignition timing		I	I					
19. Emission check in Idling		I	I					
20. Idle speed check		I	I					
21. Fuel lines		I		I				
22. Throttle operation		I		I				
23. Engine bolt tightening		I		I				
24. Engine screw torque						I		
25. Carbon cleaning for cylinder head, cylinder, piston head, and exhaust system.				I				

Have your scooter checked, adjusted periodically by your SYM Authorized Dealer to maintain the scooter at the optimum condition

Code: I ~ Inspection, cleaning, and adjustment R ~ Replacement

 C ~ Cleaning (replaced if necessary) L ~ Lubrication

The above maintenance schedule is established by taking the monthly 1000 kilometers as a reference which ever comes first.

Remarks:

1. Clean or replace the air cleaner element more often for pro-long engine life-span when the scooter is operated on dusty roads or in the Heavily- polluted environment.
2. Maintenance should be performed more often if the scooter is frequently operated in high speed and after the scooter has accumulated a higher mileage.

Air Cleaner

Remove the mounting screw from the air cleaner cover
 Remove the air cleaner cover

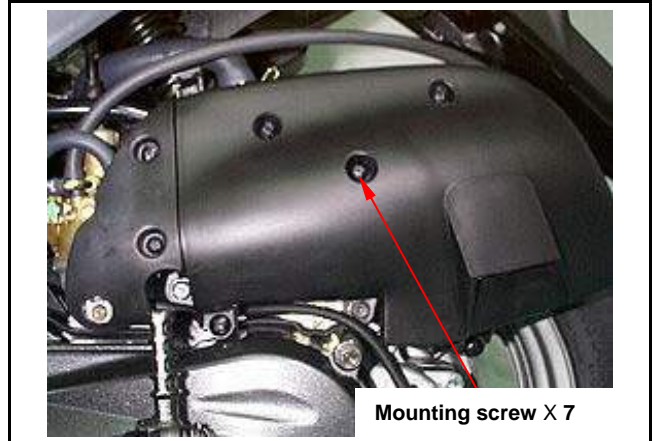

Remove the air cleaner element
 Clean the element with non-flammable or high-flash point solvent and then squeeze it for dry.

⚠ Caution

Never use gasoline or acid organized solvent to clean the element.

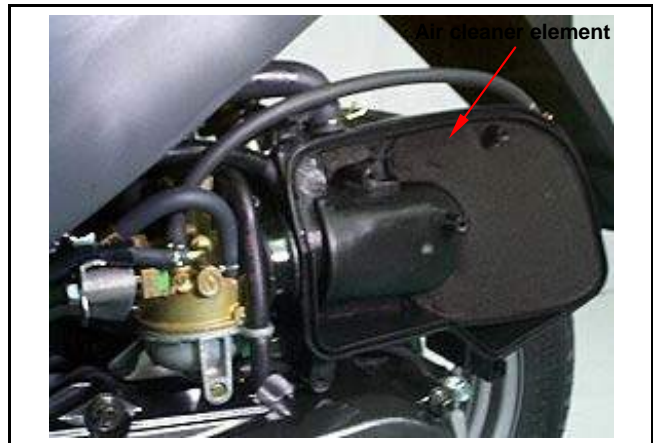

Soap the element into cleaning engine oil and then squeeze it out. Install the element onto the element seat and then install the air cleaner cover.

Limit to use SAE 20 JASO FC class engine oil, otherwise, SYM is no responsible for the warranty.
 Recommended engine oil: MAX-2 serial oils.

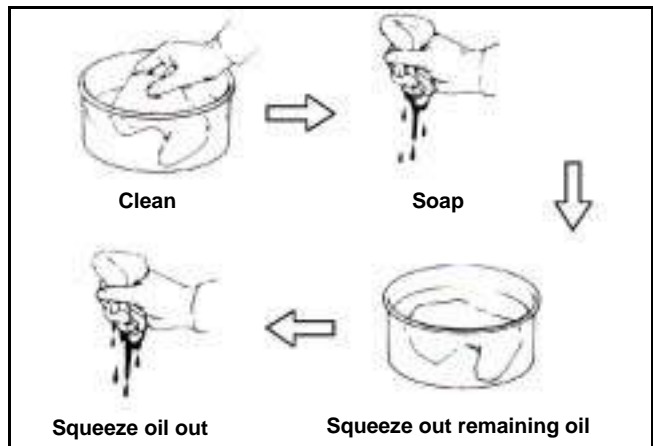

Fuel Lines

Remove the body cover
 Check fuel lines and replace damaged lines if found.
 Install the body cover.

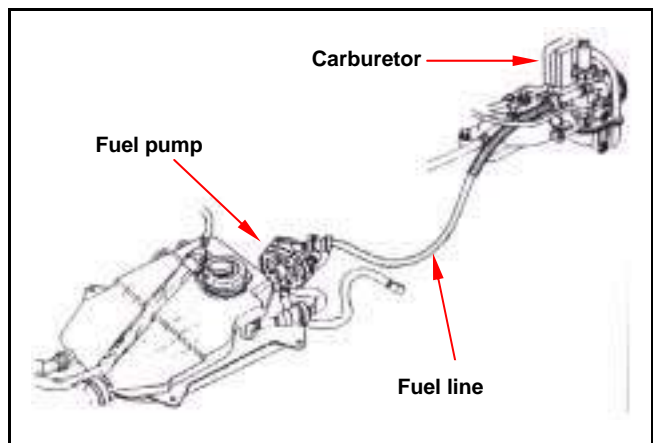

2. SERVICE MAINTENANCE INFORMATION



Fuel Filter

Remove the luggage box.
 Remove the fuel line from the fuel filter.
 Replace the fuel filter with new one.
 Install the fuel filter. The arrow indicates the fuel flowing direction.
 Check the fuel line for leaking.

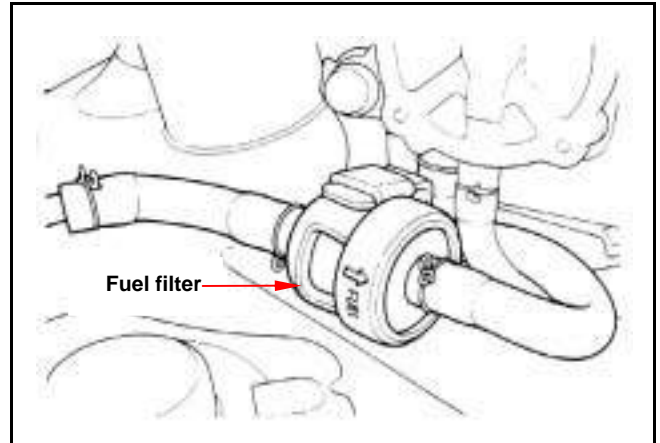

Engine Oil Line

Remove the body cover.
 Check the engine oil line and replace damaged parts.
 Remove the filling pipe from the oil pump, and drain oil into a cleaning container.
 Loosen the clamp under the engine oil tank, and then remove the oil pipe.
 Bleed the air inside the oil pump and oil pipe if air found.
 Install the body cover.

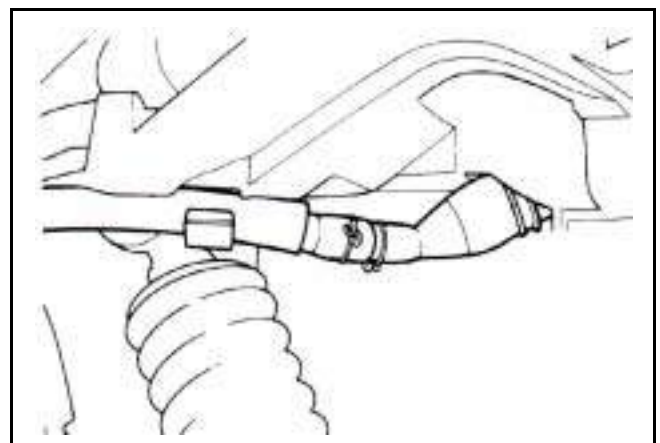
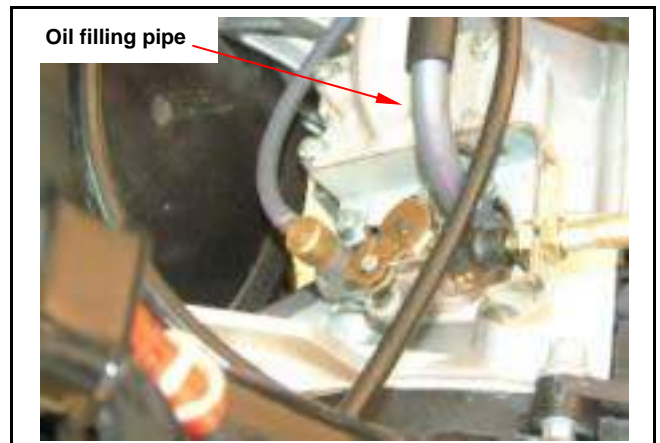
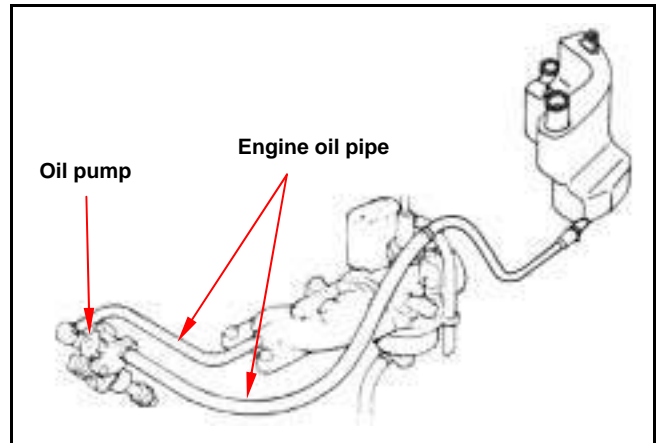

Oil Pump Control Cable

Caution

To adjust the oil pump control cable after adjusted the throttle grip play.

Remove the body cover.

Wide open the throttle valve, and check if the calibration point aligns on the oil pump lever with the mark of pump body.

Loosen the adjustment nut of the oil pump control cable.

Turn the adjustment nut and align with the point, then tighten the nut.

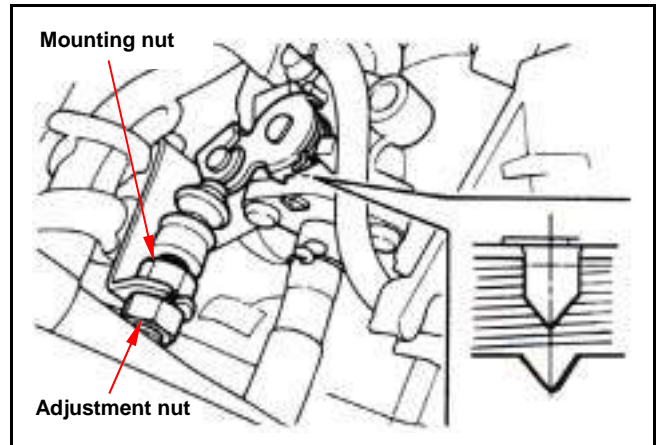

2. SERVICE MAINTENANCE INFORMATION



Tire

⚠ Caution

Tire pressure should be checked when cold.

Check tire for cracks, damage, nail, or other object stuck in tread.

Recommended tire and tire pressure

Tire size	Front: 3.00-10 42J	Rear: 3.00-10 42J
Tire pressure (cold) kg/cm ²	1.75	2.0

Check if the tire tread and wall rubber for crack or damage, and replace if necessary.

Check if foreign materials such as nail, metal pieces, and stones stuck on tire.

The thread depth can be checked by visual inspection or by a depth gauge.

If the tread bend too much, replace the tire.

If tire wear exceeds limitation, replace the tire, and check it for un-even wear.

⚠ Caution

Wear indicator “ ” is distributed on average along the wall rubber for check.

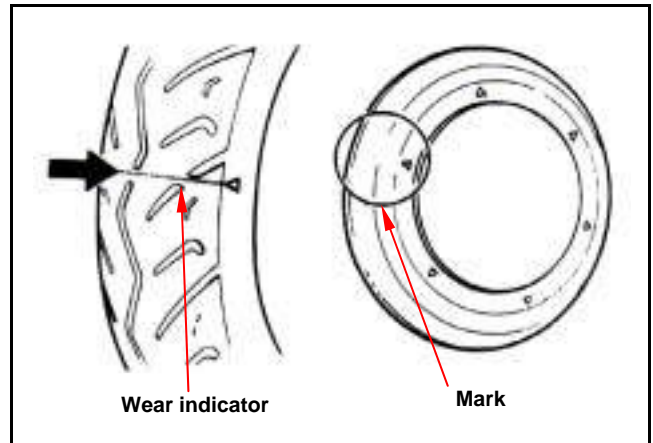
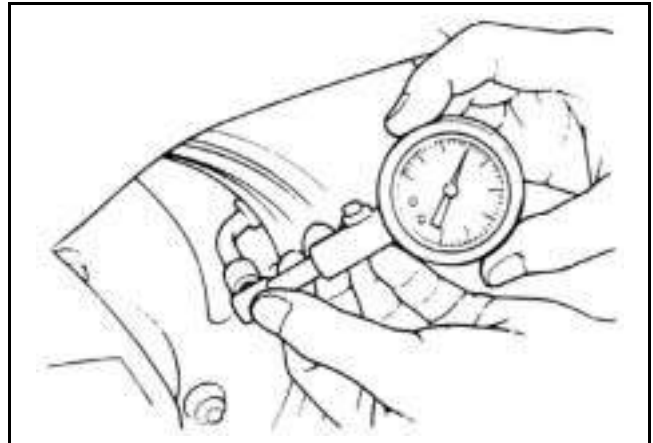

Battery

Open the seat.

Loosen two screws of battery cap and then remove the cap. Check if the battery terminals are loosen. Remove the battery if its terminals are corroded obviously.

Battery Removal

1. Remove the Negative (-) battery cable at first.
2. Then, remove the Positive (+) battery cable.
3. Remove the battery.

Clean the rust with steel brush.

Install the battery in reverse order of removal, and apply with grease onto two terminals.

⚠ Caution

The electrolyte is contained sulfuric acid so be careful not to let it touch to eyes, skin, or clothes. If touched by accident, flush them with clean water immediately. However, if the electrolyte sprays to eyes, medical care should be done quickly.

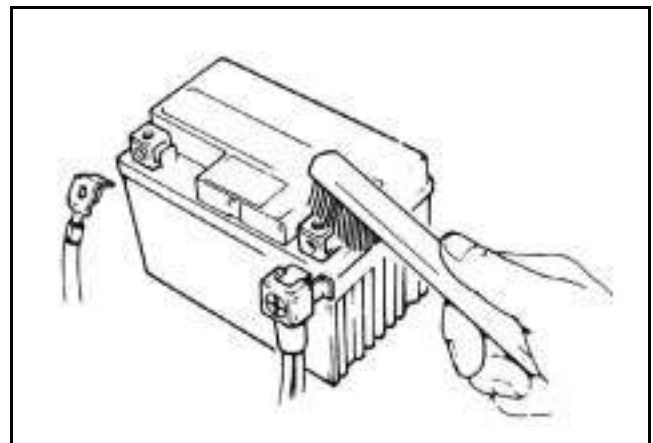
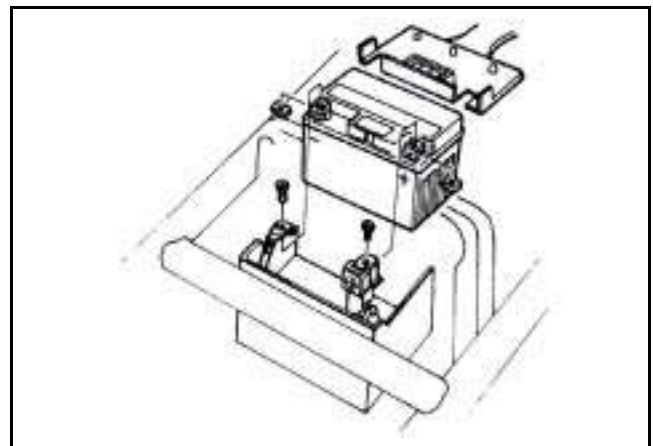

Rear Brake Free Play: (Drum Brake Type)

Measure the free play of the rear brake lever at the end of the lever.

Free play: 10-20 mm (3/8-3/4 in)

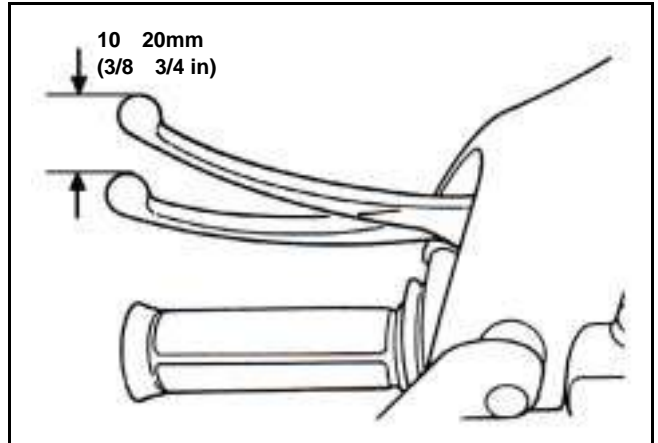

Adjust the free play by turning the front brake adjustment nut if necessary.

Brake Confirmation

Caution

After brake adjustment, it has to check the brake operation to make sure the front and rear wheel can be braked.

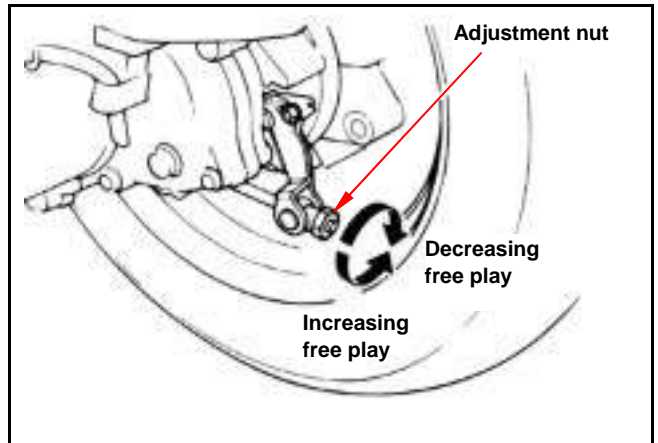

2. SERVICE MAINTENANCE INFORMATION



Brake System Hose: (Front Disc Brake Type)

Make sure that the brake hose is corrosion or damage, and also check the system for leaking.

Brake Fluid:

Check brake fluid level in the brake fluid reservoir. If the level is lower than the LOWER limit, add brake fluid DOT-3 to UPPER limit. Also check brake system for leaking if low brake level found.

⚠ Caution

- In order to maintain brake fluid in the reservoir in horizontal position, do not remove the cap until handle bar stop.
- Do not operate the brake lever after the cap had been removed. Otherwise, the brake fluid will spread out if operated the lever.
- Do not mix non-compatible brake fluid together.

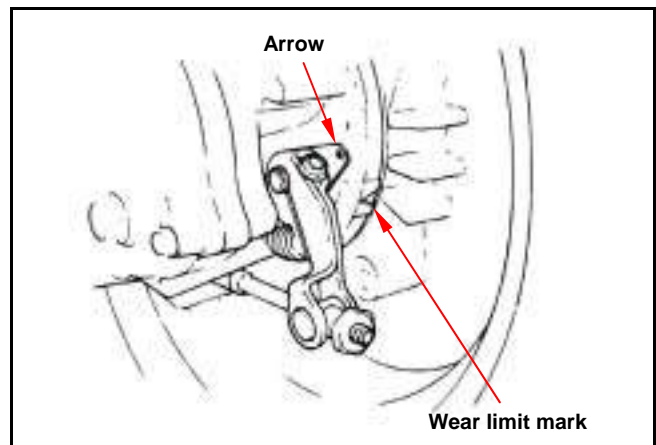
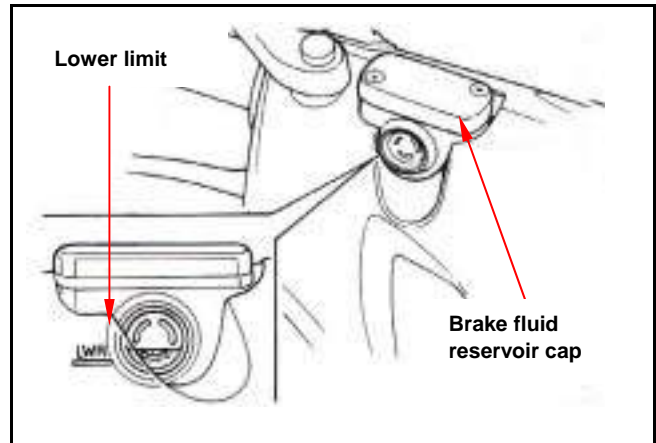

Brake Lining Wear: (Rear Drum Brake Type)

Replace the brake lining if the wear limit mark " " on the brake arm aligning with the indicator of brake drum.

Brake Lining Wear: (Front Disc Brake Type)

The arrow mark on brake lining is the wear limitation.

Replace the brake lining if the wear limit mark closed to the edge of brake disc.

⚠ Caution

- In order to maintain brake power balance, the brake lining must be replaced with one set.

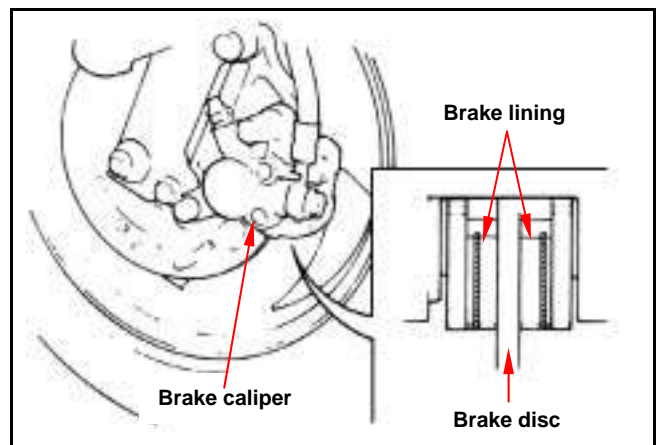

- Remove the pin bolt cap.
- Loosen the bolt.
- Remove the front wheel shaft bolt.
- Take out the front wheel.

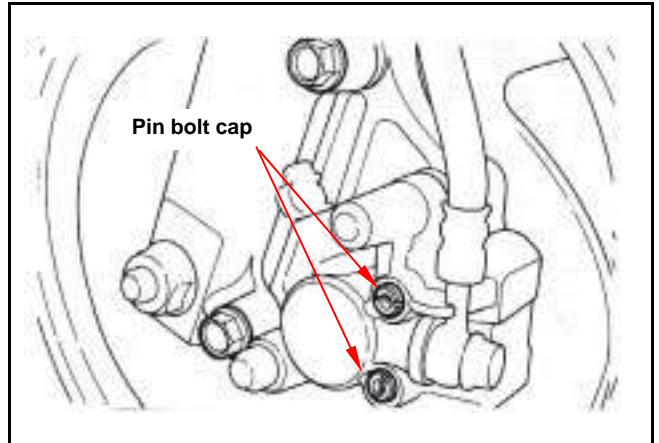

Remove brake caliper mounting bolt and then remove the brake caliper.

⚠ Caution

Do not operate the brake lever after the clipper removed to avoid clipping the brake lining.

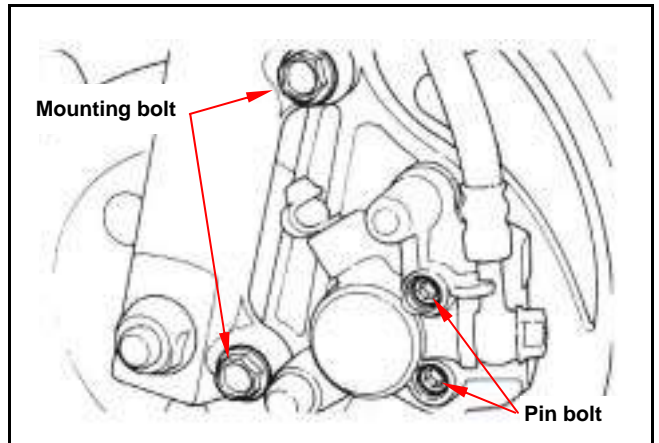

Pry out the brake lining with a flat driver if lining is clipped.

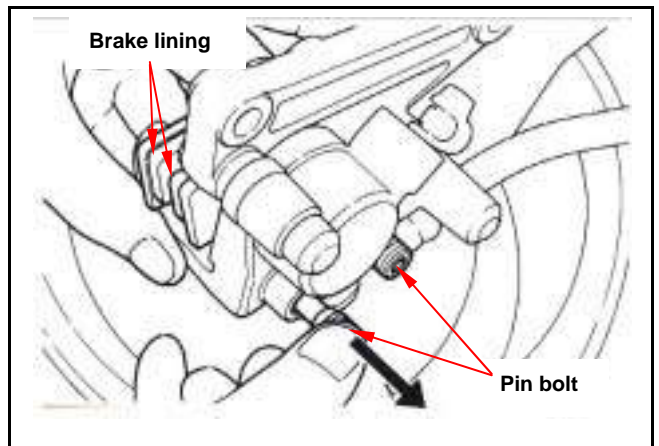

Remove brake lining bolt.
Take out the lining.

Tighten Torque:

Mounting bolt: 2.9-3.5 kgf-m

Pin bolt: 1.5-2.0 kgf-m

Pin bolt cap: 0.8-1.2 kgf-m

The brake light switch is to light up brake light as brake applied. Replace the switch if the light does not light up in properly.

⚠ Caution

The brake light switch is un-adjustable.

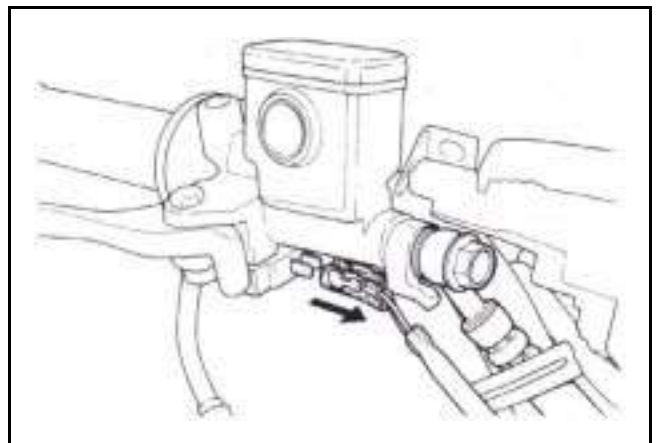

2. SERVICE MAINTENANCE INFORMATION



Steering System

⚠ Caution

The control cables can not interfere with the rotation of steering handle.

Lift the front wheel out of ground, and check if the steering handle turning is smoothly. If handle turning is uneven and bending, stuck, or the handle can be operated in vertical direction, then adjust the handle top bearing by adjusting the steering nut.

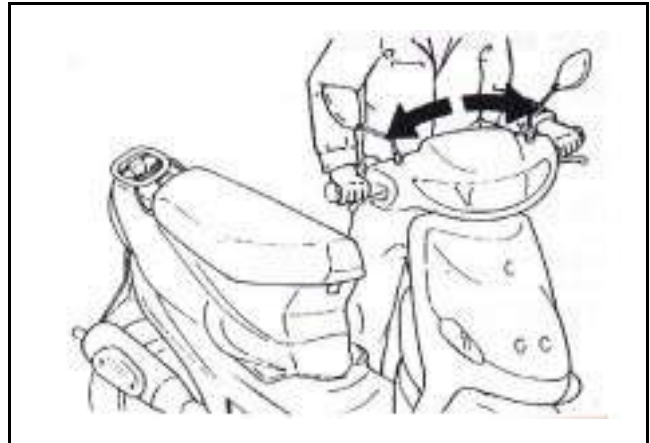

Suspension

⚠ Warning

Do not ride the scooter with poor suspension. Looseness, wear or damage suspension system will make poor stability and drive-ability.

Front Shock Absorber

Press down the front shock absorber for several times to check its operation. Check if the shock absorber assembly is damaged. Replace it if damage is found and cannot be repaired. Tighten all nuts and bolts.

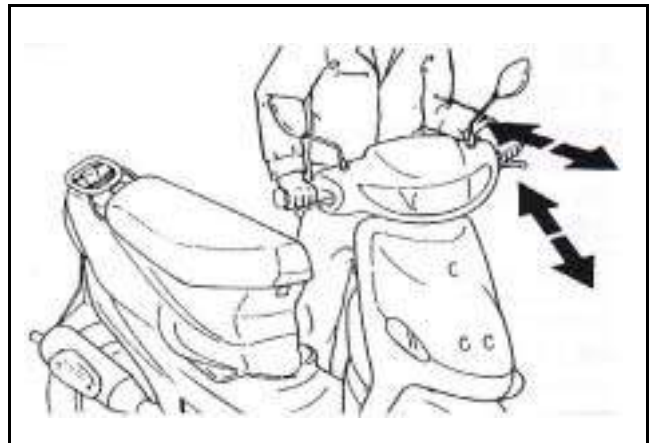

Rear Shock Absorber

Park the scooter with its main stand. Shake the rear wheel side to side to check engine suspension bushing for wear. Replace the bushing if looseness is found. Check the shock absorber for damage. Tighten all nuts and bolts.

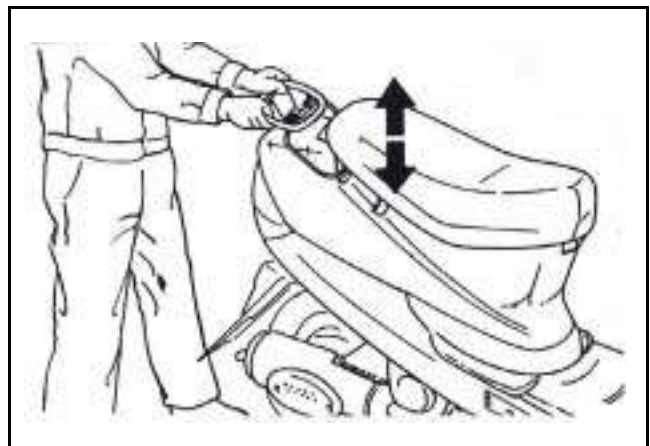

Nuts, Bolts Tightness

Check if all bolts and nuts on the frame are tightened to specified torque in accordance with the interval of Periodical Maintenance Schedule. Check all split pins, snap rings, hose clamps, and wire holders for security.

Transmission Oil

Leak

Check if the transmission is leak.

Check

Caution

Park the scooter on flat ground with its main stand.

Remove the oil level check bolt, and check if the oil level is placed on the hole of check bolt.

Replacement

Remove the oil level check bolt.

Remove the oil draining bolt, and then drain oil out.

Install the oil draining bolt.

Tighten torque: 1.3 kgf-m

Caution

Check if oil seal and washer is in good condition.

Replacement Quantity: 0.09 L (90 cc)

Recommended oil: King Bramax HYPOID GEAR OIL #140

Spark Plug

Recommended plug: NGK BR8HSA

- Remove the luggage box.
- Remove the spark plug cap.
- Clean any dirt on the spark plug seat.
- Remove the spark plug.
- Visually inspect the spark plug electrodes for wear.
- The center electrode should have square edges and side electrode should have a constant thickness. Replace the spark plug if there is apparent wear or if the insulator is cracked and/or chipped. If the spark plug deposits can be removed by sandpaper, the spark plug can be reused.
- Measure the spark plug gap with feeler gauge.

Spark plug gap: 0.6-0.7mm (0.024-0.028in)

- Adjust the gap by careful bending the side electrode.
- Install the spark plug by screwing it with hands after installed the spark plug washer so that can prevent the plug from out of thread. Then, tighten the spark plug with a spark plug wrench.
- Install the spark plug cap.

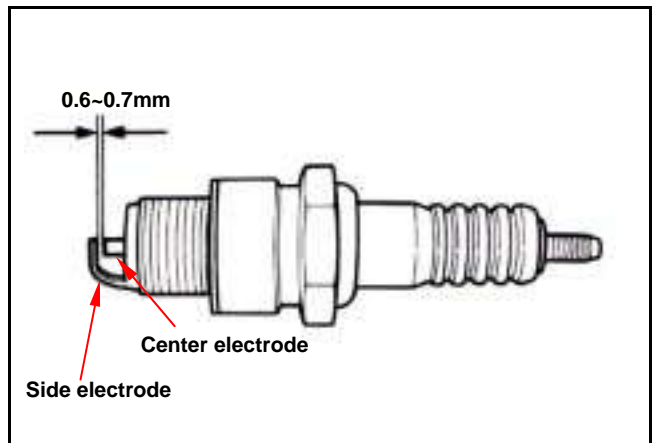
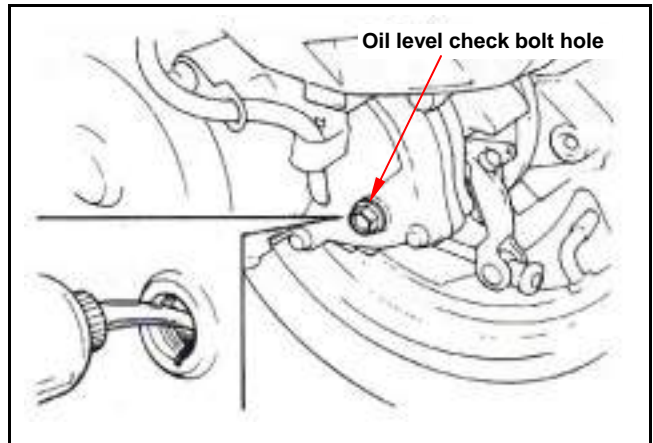
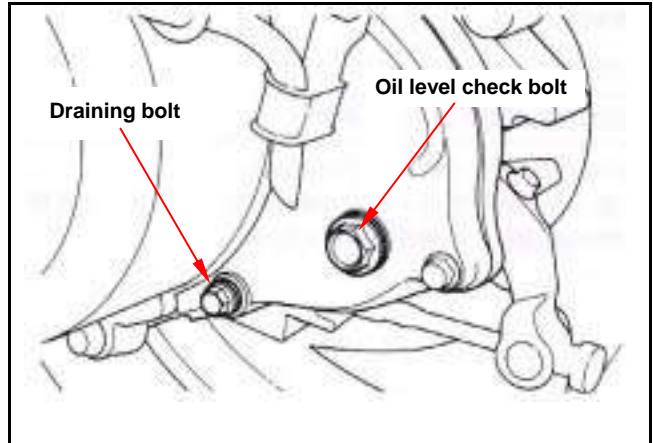

Control Cable Lubrication

Remove the throttle control and the brake cables periodically, and lubricate the moving parts of the cables thoroughly.

Driver Belt

- Remove left crankcase cover.
- Check if the belt is crack or worn out.
Replace the belt if necessary.
- Measure the driving belt width

Allowable limit: 16.5mm

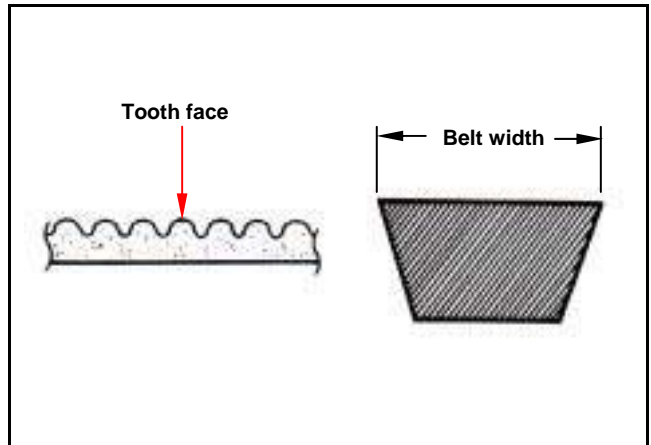

Ignition Timing

⚠ Caution

- C.D.I ignition timing can not be adjusted. If the ignition timing is incorrect, check the C.D.I. device and the alternator and replace damaged components.
- Check ignition timing with standard instrument.

Remove the right-side cooling fan cover. Check ignition timing with the timing light. When engine speed setting to 1800 rpm, and if the mark aligns with "F" mark, then it means that the ignition timing is correct.

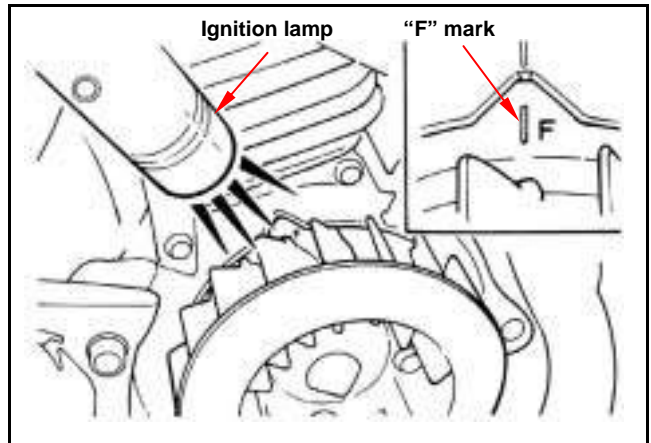

Throttle Valve Operation

Check if each steering positions are operated in smooth, and handle bar if its operation is smooth as the throttle valve wide opening or fully closed. Check throttle cable and replace it if deteriorated, twisted or damaged.

Lubricate the cable if operation is not smooth
Measure throttle valve handle free play.

Free play : 2~6 mm (1/8-1/4 in)

Loosen the mounting nut, and turn the free play adjustment nut of the throttle valve handle for adjustment.

Replace the cable if it can not be adjusted.

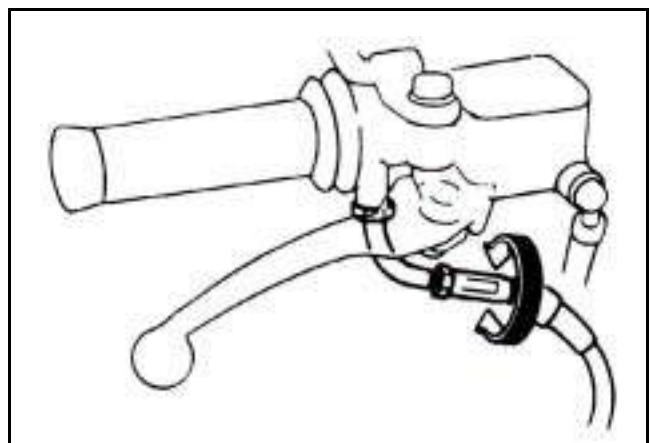
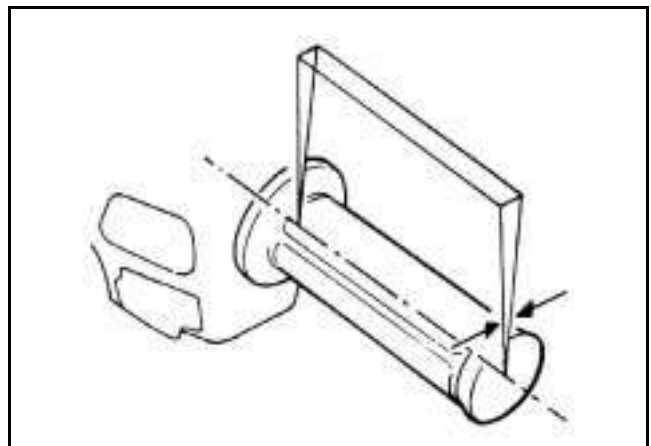

Carburetor Idle Speed Adjustment

⚠ Caution

- Inspection & adjustment for idle speed have to be performed after all parts in engine had been adjusted in specification.
- Idle speed check and adjustment have to be done after engine is being warm up. It around operates engine from stop to running for 10 minutes.

Remove the body cover.

Park the scooter with main stand after warmed up engine. According to the required idling and air screw to adjust to specified idle speed.

Idle speed: 2000±100 rpm

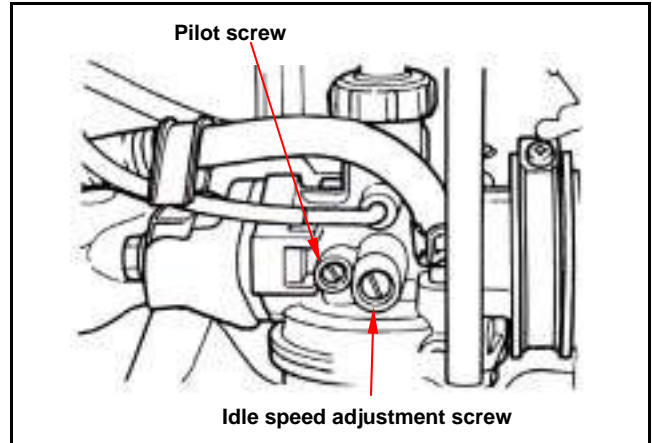

Adjust the idling after warm up engine for 10 minutes.

1. Connect tachometer.
2. Adjust the idle speed screw to let engine speed in 2000±100 rpm.
3. Insert the sampling pipe of the CO/HC meter to the test hole on the front end of exhaust pipe. Adjust the idling emission value to standard range. (CO: 1.8-2.6%)
4. Slightly accelerate the throttle valve and release it. Repeat this operation for 1-2 times.
5. Read the engine idle speed and the emission value after engine speed in stable. Repeat the operation on step No. 2 – No. 4. until these value within standard range.

Carbon Removing For Exhaust Pipe & Muffler

Remove the body cover.

Remove the exhaust pipe & muffler.

Clean the carbon deposits on the muffler & cylinder exhaust edge.

Cylinder Compression Pressure Test

Remove the left body cover, and warm up engine. Stop the engine and remove the spark plug. Insert the compression gauge and wide open the throttle, and then rotate the engine by means of the starting motor.

Compression pressure: 7.0±1 kg/cm²

Probable causes for low compression pressure.

- Damaged cylinder head gasket.
- Worn piston ring
- Worn cylinder

Probable causes for high compression pressure.

- Carbon on the combustion chamber or cylinder head

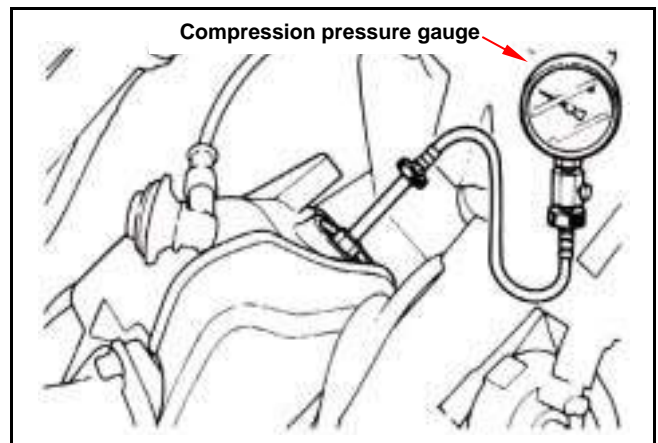

2. SERVICE MAINTENANCE INFORMATION



Headlight Adjustment

Loosen headlight mounting bolt.
Move the headlight for adjustment its light beam.
Tighten the headlight mounting bolt after adjusted.

⚠ Caution

Improper headlight beam adjustment will make in coming driver dazzled or insufficient lighting for safety distance.



Lubrication System Diagram3-1	Oil Pump Removal 3-3
Precautions In Operation3-2	Oil Pump Installation 3-3
Lubricant3-2	Oil Pump/Oil Tube Air Bleeding 3-4
Trouble Shooting3-2	Oil Tank 3-5

Lubrication System Diagram

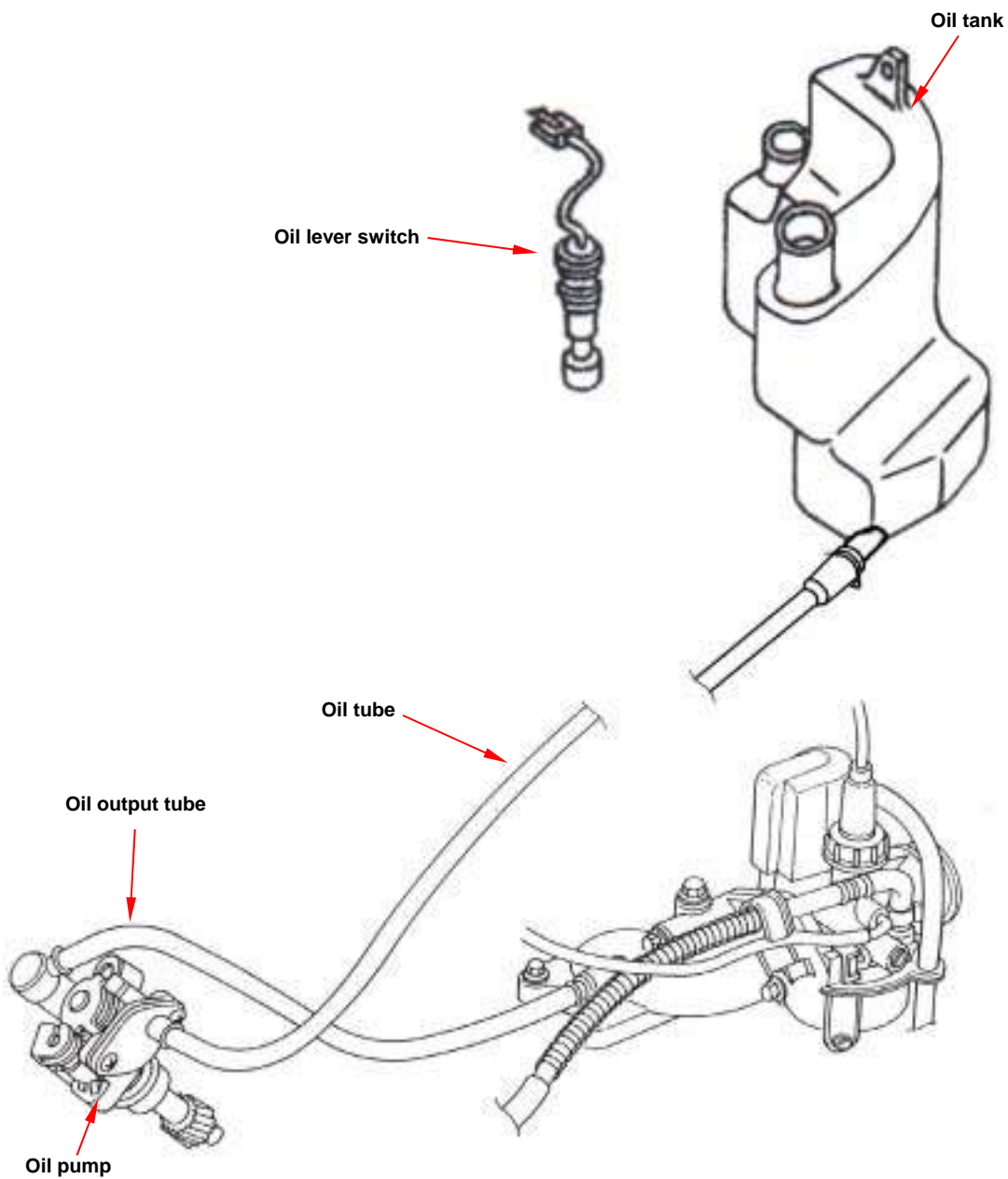

3. LUBRICATION SYSTEM

Precautions In Operation

- Be careful not let dirt enter into engine or oil hoses when removing or installing the oil pump.
- If air is found in the oil tube (from oil tank to oil pump) or oil tube is removed, the oil pump should be conducted air-bleeding operation.
- It should bleed the oil output tube (from oil pump to carburetor) as hose removed.
- The adjustment of oil pump control cable.

Lubricant

- Appointed to apply SAE 20 JASO FC class oil. Otherwise, warranty shall not cover the damage.
- Recommended Oil: MAX-2 oil.
- Oil tank capacity: 1.2 lit.

Trouble Shooting

Too much smoke, carbon in spark plug.

1. Improperly oil pump adjustment (too much oil).
2. Poor quality oil.
3. Applying with poor quality oil.

Over heat

1. Improperly oil pump adjustment (insufficient oil).
2. Poor quality oil.
3. Applying with poor quality oil.

Piston seized

1. No oil in oil tank or clogged hose.
2. Improperly oil pump adjustment (insufficient oil).
3. Air in oil hose.
4. Malfunction of oil pump.

Oil did not flow out the oil tank

1. Clogged breath hole on the oil tank cover.

Oil Pump Removal

⚠ Caution

Before removing the oil pump, clean the oil pump and crankcase.

Remove the luggage box and seat.
Loosen the mounting nut of the oil pump control cable, and remove the control cable.
Remove the oil tube, and clip its end side to prevent oil from flowing out.

Remove the oil output tube form intake manifold.
Remove the oil pump mounting bolt, and then take out the oil pump.

Inspection

Inspect the following items on the removed oil pump.

- Check if O-ring is damaged or softening.
- Check if crankcase interface is damaged.
- Check if pump body is damaged.
- Check if pump gear is damaged.
- Check for oil leaking.

⚠ Caution

The oil pump can not be disassembled.

Oil Pump Installation

Install the oil pump onto the crankcase.

⚠ Caution

- Apply with some grease onto oil pump O-ring.
- The connection between both oil pump and crankcase has to be installed in position security.

Tighten the oil pump mounting bolt security.
Install the oil tube.
Installation in the reverse order of removal.

⚠ Caution

Inspection and adjustment following items as installed.
The adjustment operation of control cable.
Air bleeding operation of oil pump.
Air bleeding operation of oil tube.
Check each section for leaking.

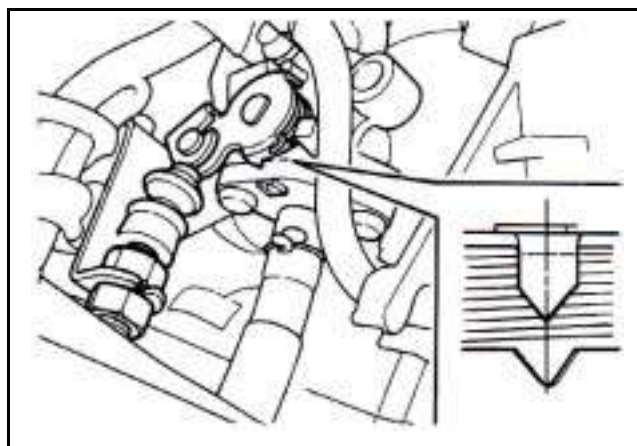
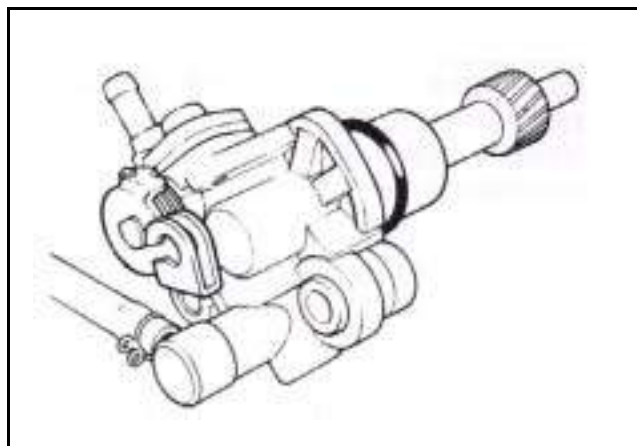
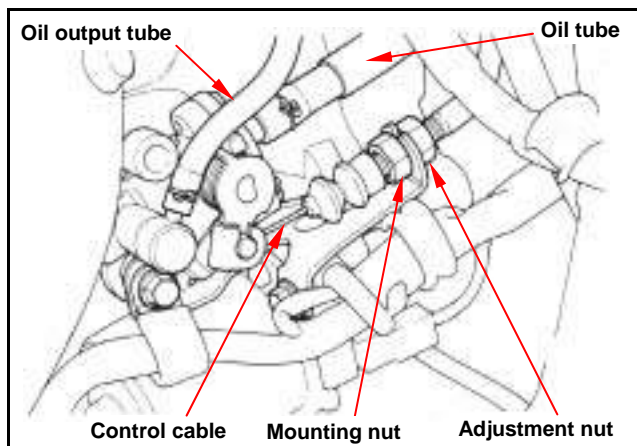

3. LUBRICATION SYSTEM

Oil Pump/Oil Tube Air Bleeding

⚠ Caution

The oil tube system has to be conducted air bleeding operation because air will clog or restraint oil flowing so that cause serious engine damage.

⚠ Caution

After disconnect the oil tube, air enters oil tube due to oil leak out without added oil. There is why the oil tube and oil pump have to conduct air bleeding operation.

Oil Tube/Oil Pump

- It has to add some oil into the oil tank.
- Place a piece of dry cloth around the oil pump.
- Disconnect the oil tube.
- Fill out oil to oil pump connection section by means of the oil pot so that the oil pump body is full with oil.
- Fill out oil to oil tube connection section so that the oil tube is full with oil. Then, install the tube onto oil pump.
- Make sure whether air is in the oil tube or not after installation.

⚠ Caution

After bleeding the oil tube and oil pump, the oil tube has to be conducted air bleeding operation too.

Oil Tube Air Bleeding

Remove the oil output tube and plug its input connector. Bend the oil tube into "U" shape, and fill out new oil into the output tube.

Connect the oil output tube to the oil pump connection part.

Start engine, and run it in idling as the oil control lever in wide open position. Make sure oil flows out from the oil output tube.

⚠ Caution

- Motorcycle's exhaust gas includes with CO which causes human to coma or death so perform this operation in well-ventilation place.
- Run the engine in extreme low speed to avoid to damaging the engine caused from clogged oil tube.

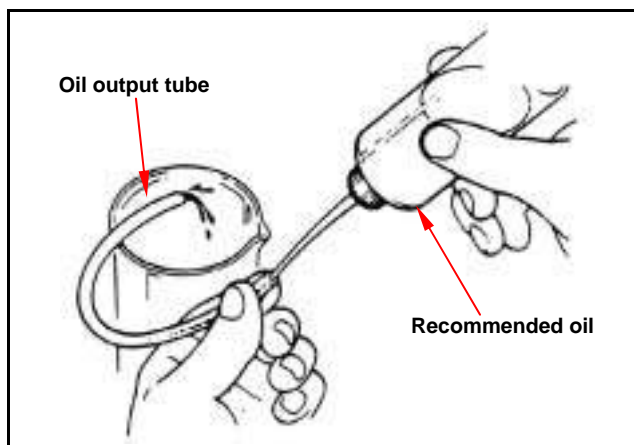
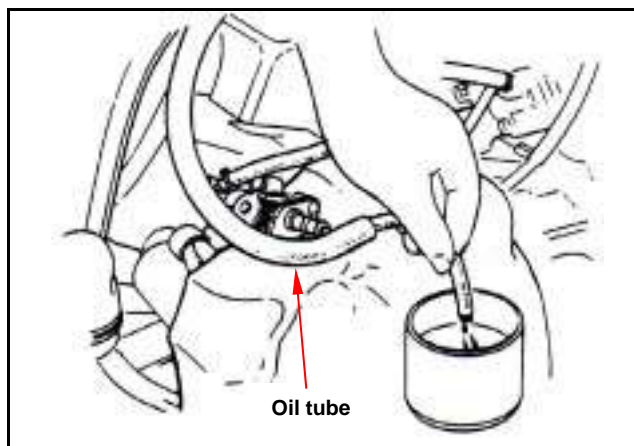
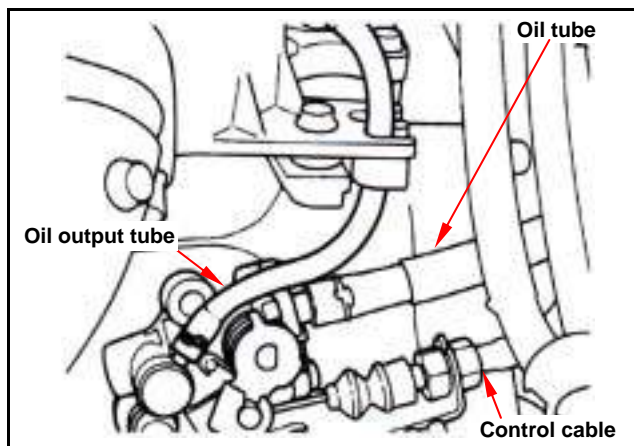

Oil Tank

Removal/Installation

Remove the battery and oil tank cap.
Remove the luggage box and seat.

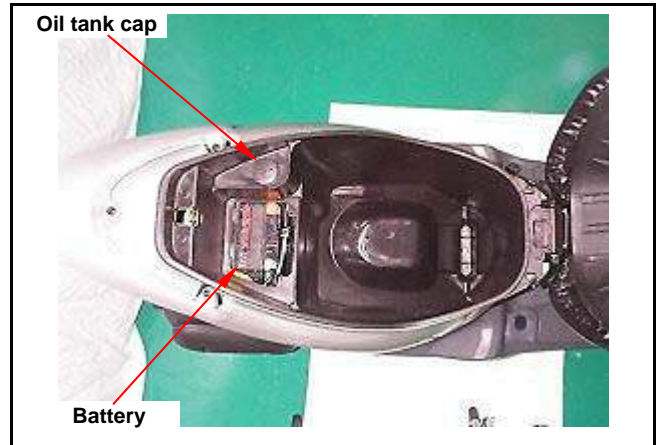

Remove the oil input tube from oil pump, and then drain oil to a clean container.

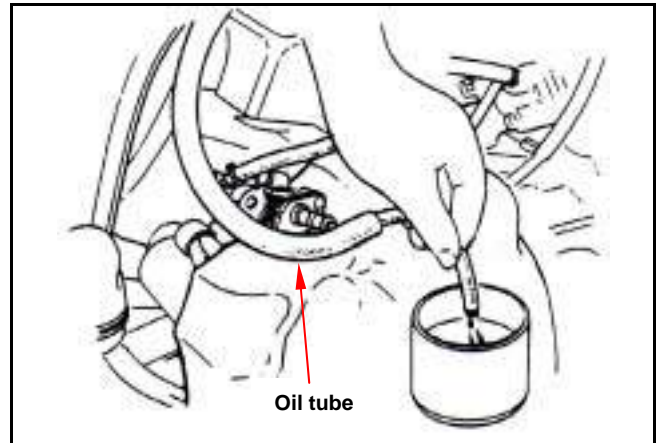

Remove the oil level switch wire of the oil indicator.
Remove the mounting bolt on the oil tank upper side, and then remove the oil tank.
Installation in the reverse order of removal.
Air bleeding the oil tubes after installed.

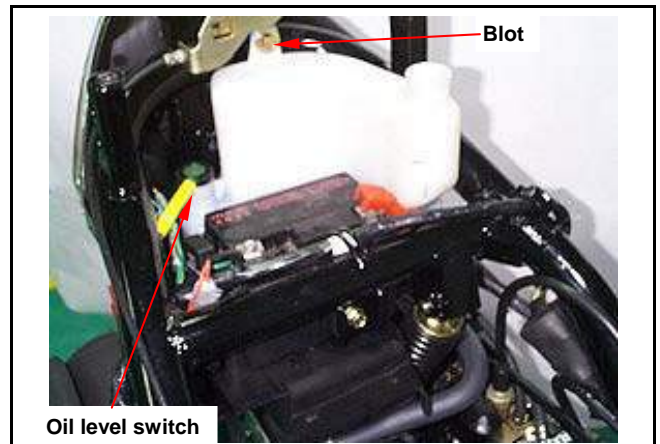

3. LUBRICATION SYSTEM



Notes:

Maintenance Information4-2	Engine installation 4-5
Engine removal.....4-3	

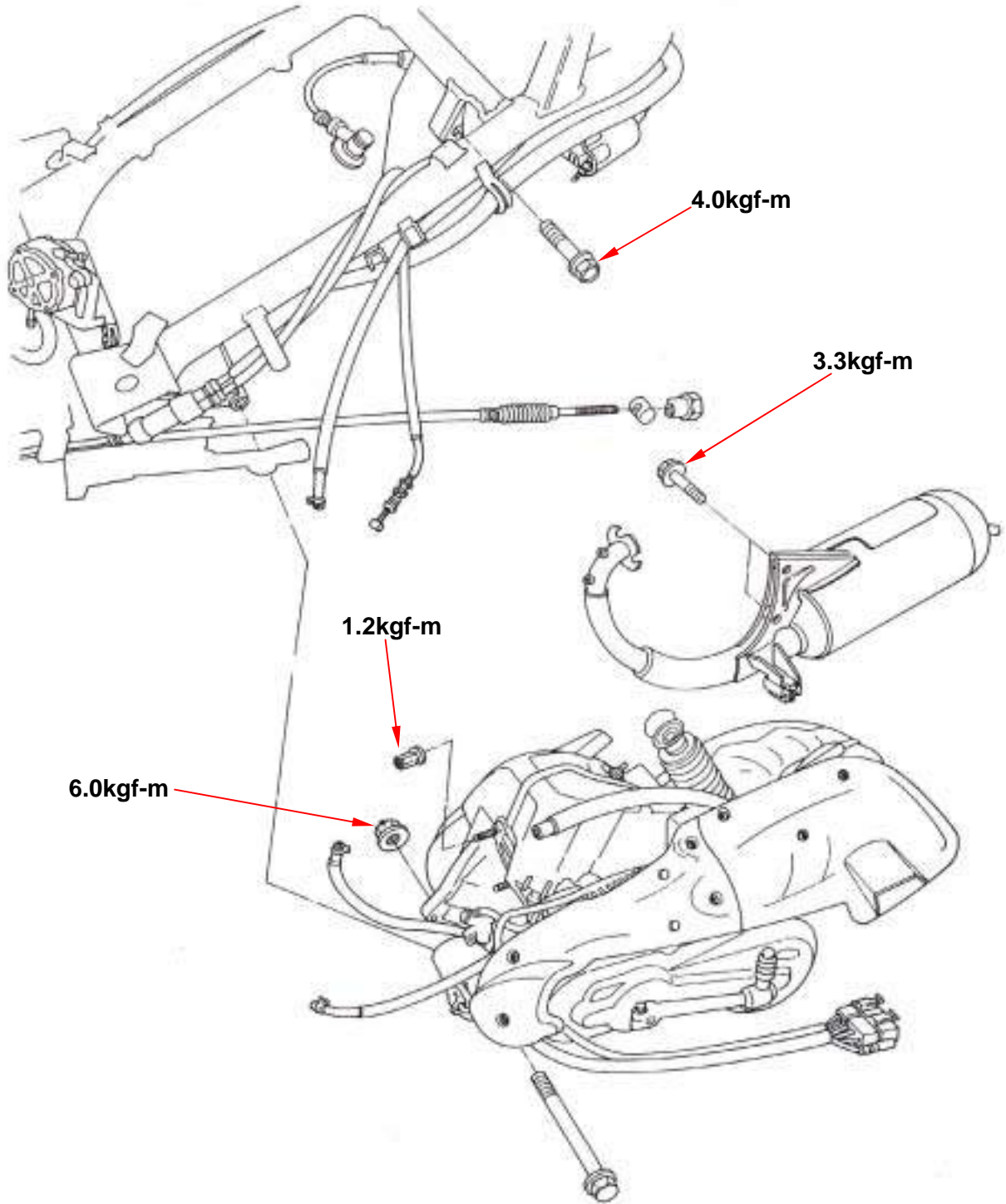

4. ENGINE REMOVAL

Maintenance Information

There are parts that require removal of engine for maintenance.

- Crankcase
- Crankshaft

Related bolts tightening torque for removal of engine:

Engine hanger bolt	5.0kgf-m
Engine bracket bolt	6.0kgf-m
Rear shock absorber upper mounting bolts	4.0kgf-m
Rear shock absorber lower mounting bolts	2.7kgf-m
Exhaust pipe connection nut	1.2kgf-m
Muffle mounting bolt	3.3kgf-m

Engine removal

Remove body cover.
Remove the spark plug cap from the spark plug section.

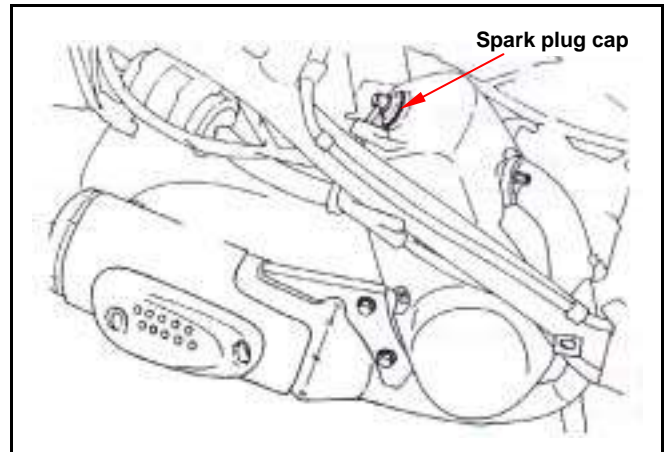

Remove the fuel output and the vacuum tubes from fuel pump.
Remove the oil control cable from oil pump.
Remove the oil tube from oil pump and then clip the tube.

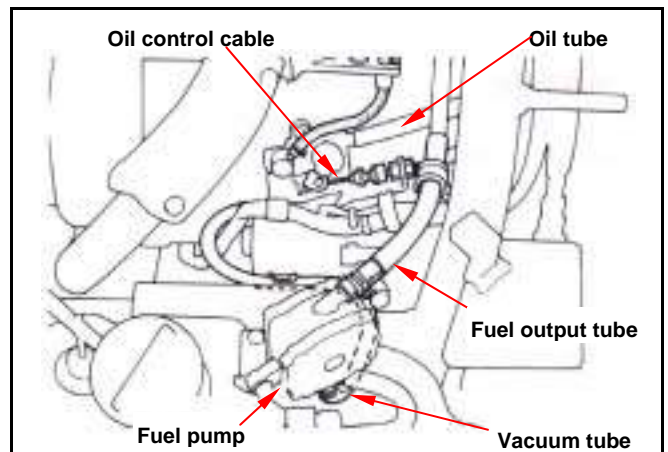

Remove the wire connectors of auto by starter and AC.G.

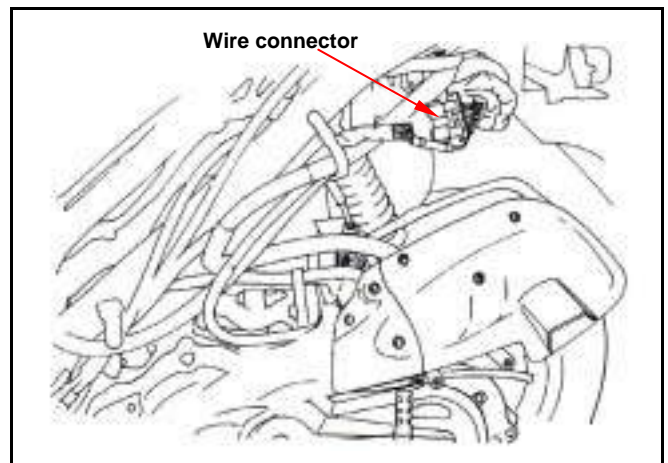

Remove the upper parts and cable of the carburetor from its upper side.
Remove the vapor emission vacuum tube from carburetor intake manifold.



4. ENGINE REMOVAL

Remove rear brake cable from engine rear-lower side.

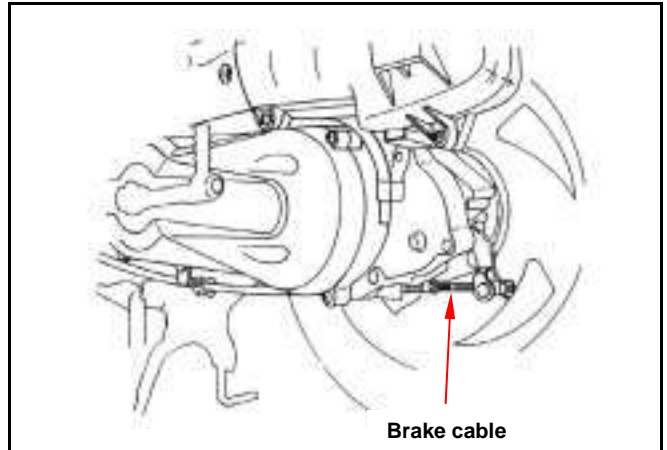

Remove air cleaner mounting bolts. (2 bolts)

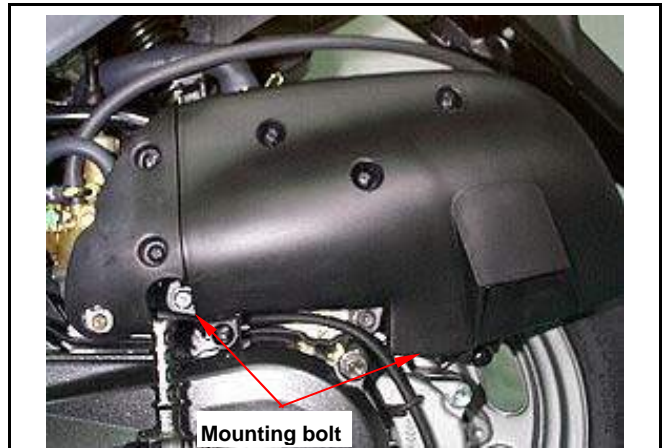

Support the engine and then remove shock absorber lower mounting bolt.



Remove two exhaust pipe connection nuts.
Remove two bolts beside fan cover and exhaust pipe.

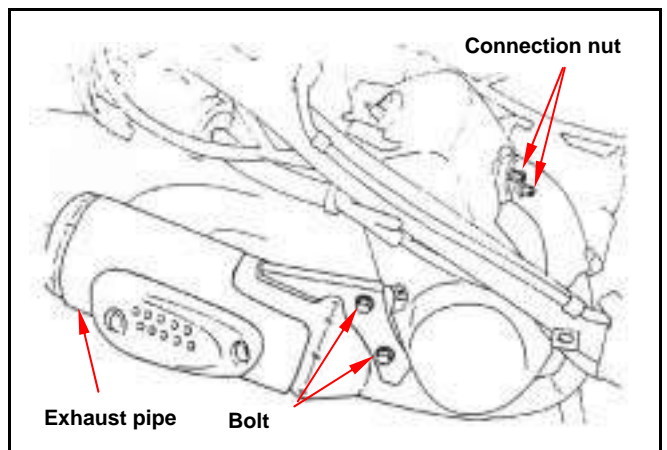

Remove engine mounting nut and bolt.

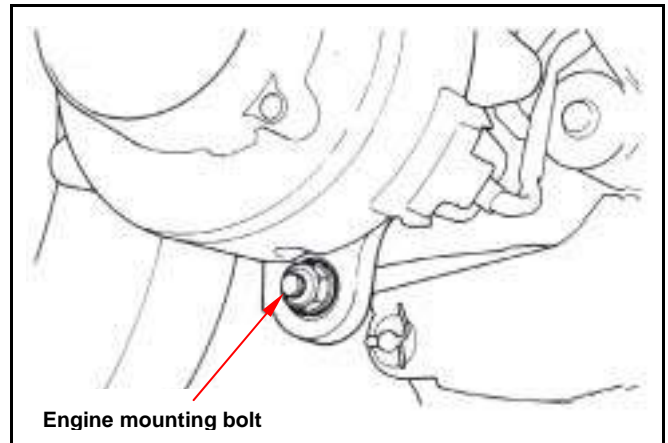

Engine installation

Install in the reverse order of removal procedures.
Tighten the engine mounting and rear shock absorber upper/lower bolts.

Torque value:

Engine hanger bolt:	5.0kgf-m
Rear shock absorber upper mounting bolts:	4.0kgf-m
Rear shock absorber lower mounting bolts:	2.7kgf-m
Exhaust pipe connection nut:	1.2kgf-m
Muffler mounting bolt:	3.3kgf-m

Perform the following inspection and adjustment after installation.

- Check if control cable is correct.
- Check if throttle valve cable is correct.
- Check if oil pump control cable is correct.
- Oil input and output of the oil pump.
- Adjust rear brake.

4. ENGINE REMOVAL



Note:

5. CYLINDER HEAD/CYLINDER/PISTON

Maintenance Information.....5-2	Cylinder Head.....5-3
Troubleshooting.....5-2	Cylinder/Piston.....5-5

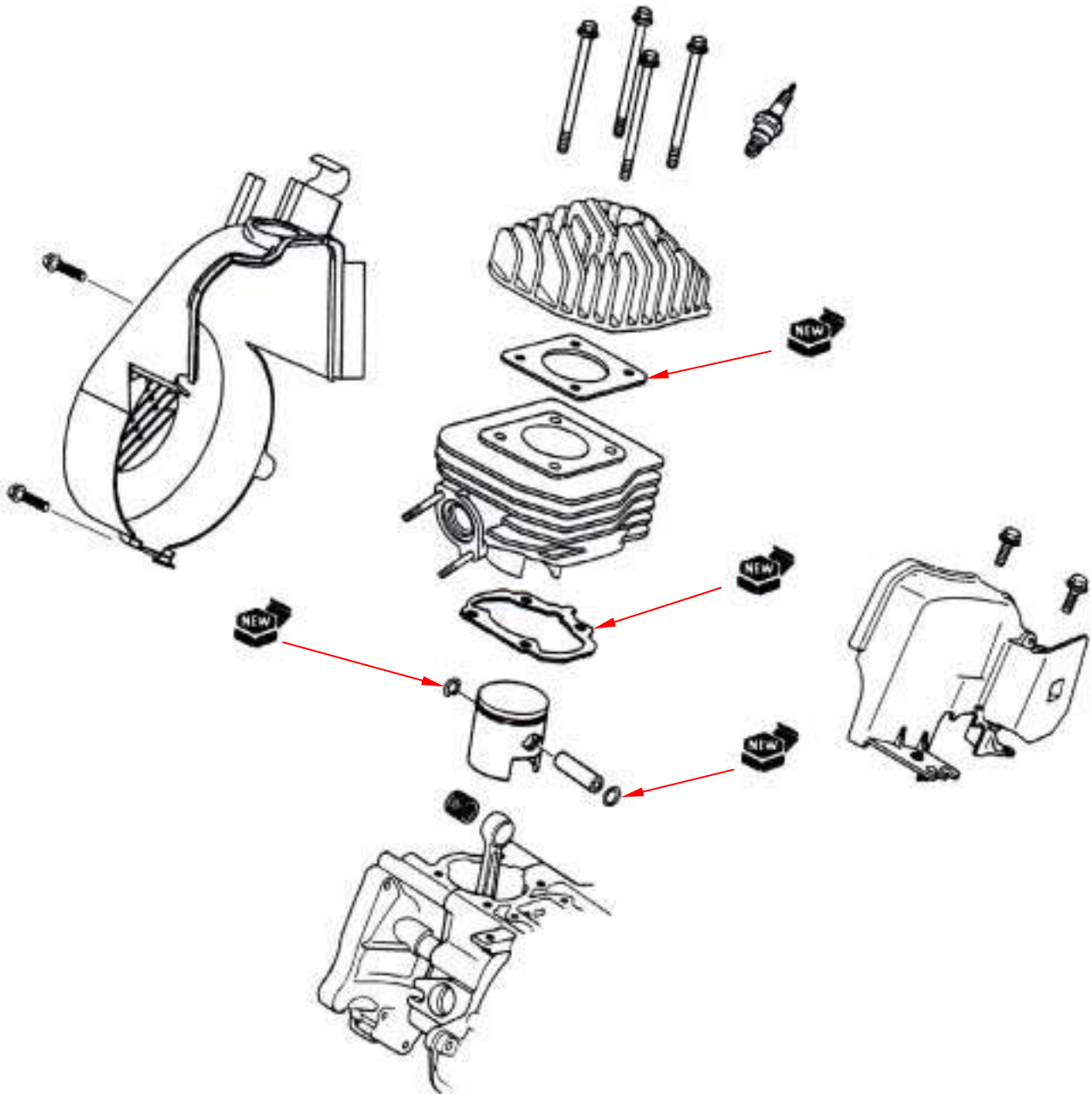

5. CYLINDER HEAD/CYLINDER/PISTON



Maintenance Information

Precautions in Operation

- The inspection and maintenance of the cylinder head, cylinder and piston can be carried as engine mounted on the body.
- It should clean the engine to prevent dirt from entering into cylinder and crankcase before removal.
- Remove all washes from the interfaces of cylinder head, cylinder and crankcase.
- Be careful do not damage cylinder head, cylinder and piston when removing.
- Inspect the removed & cleaned parts thoroughly, and apply with oil onto the rotation surfaces before installation.

Specification

Item		FT05 series	
		Standard value (mm)	Limit (mm)
Cylinder head	Deformation	-	0.100
Piston	Piston OD	39.030~39.045	38.935
	Clearance between cylinder and piston	0.040~0.050	0.100
	Piston pin hole	12.002~12.008	12.030
	Piston pin OD	11.994~12.000	11.970
	Clearance between piston and piston pin	0.002~0.014	0.030
	Piston ring end gap	0.100~0.250	0.400
Cylinder	ID of connecting rod small end	17.05~17.015	17.025
	ID	39.000~39.015	39.050
	Deformation	-	0.100

ID: inner diameter

OD: outer diameter

Tighten torque value

Cylinder head	1.0kgf-m	Exhaust pipe connection nut	1.2kgf-m
Spark plug	1.4kgf-m	Exhaust muffler mounting bolt	3.3kgf-m

Troubleshooting

Compression Pressure Too Low/Difficult To Start/Rough Idling

1. Cylinder head gasket leaking
2. Spark plug not tighten enough
3. Worn, seized or crack piston ring
4. Damaged, worn cylinder or piston
5. Poor reed

Compression Pressure Too High/Overheat/Knock

1. Too much carbon deposit built up in combustion chamber

Piston Noise

1. cylinder and piston worn out
2. piston pin or piston pin hole worn out
3. connecting rod small end bearing worn out

Piston Ring Noise

1. Worn, seized or crack piston ring
2. Cylinder worn out or damaged

Cylinder Head

Cylinder Removal

- Removal body covers.
- Remove spark plug cap.
- Remove fan cover.
- Remove engine shield.

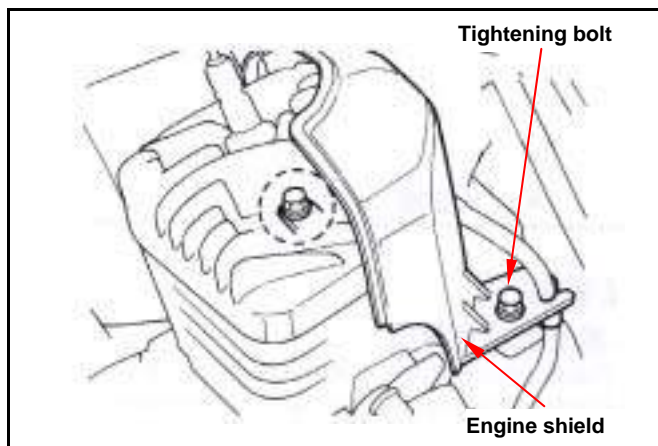

- Remove two connection nuts of the exhaust pipe.
- Remove exhaust muffler mounting bolt, and then remove the exhaust pipe.

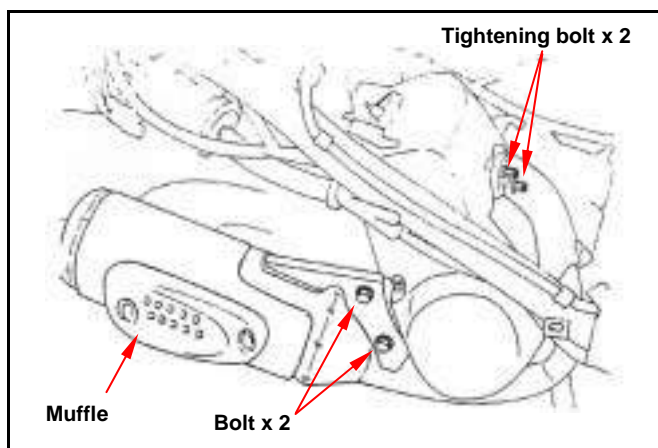

Cylinder Head Removal

- Remove the 4 cylinder head bolts and then remove the cylinder head.

Caution

Loosen the cylinder head bolts with diagonal direction to avoid to damaging it.

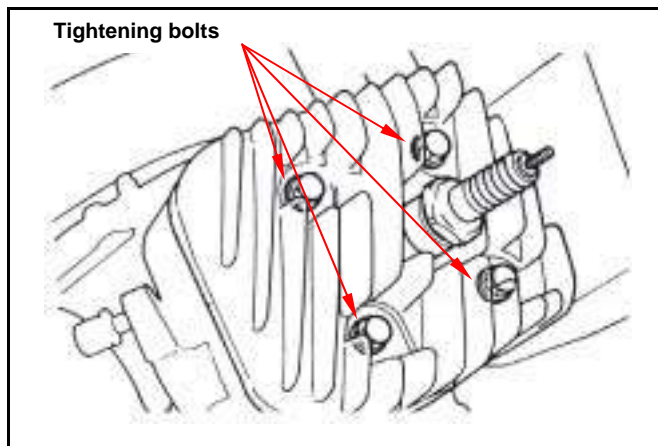

Cleaning Carbon in Combustion Chamber

- Clean carbon deposit in which built up in combustion chamber with shown chisel.

Caution

Do not scratch to the interfaces of combustion chamber and cylinder.

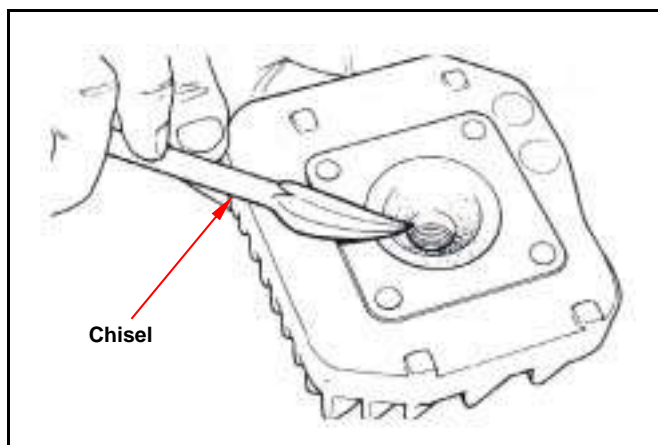

5. CYLINDER HEAD/CYLINDER/PISTON

Cylinder Head Inspection

Use a straight edge and a feeler gauge to measure the cylinder head for warp.

Service limit: 0.10 mm

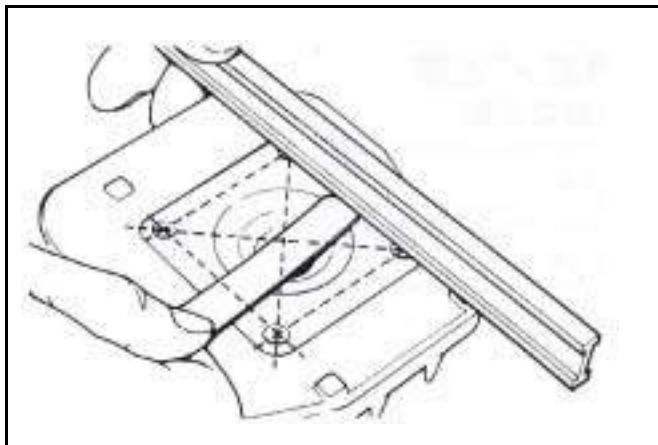

Cylinder Head Installation

Replace the cylinder head gasket with new one, and place the cylinder head onto cylinder. Tighten the 4 bolts with diagonal direction and by 2-3 sequences.

Tighten torque: 1.0kgf-m

Install spark plug

Tighten torque: 1.4kgf-m

Replace the exhaust pipe washer with new one and then install exhaust pipe.

Tighten exhaust pipe connection nut.

Tighten torque: 1.2kgf-m

Tighten exhaust pipe mounting bolt.

Tighten torque: 3.3kgf-m

Install the removed parts in the reverse order of removal procedures.

Inspect following item after installation.

Compression pressure test.

Check for engine noise.

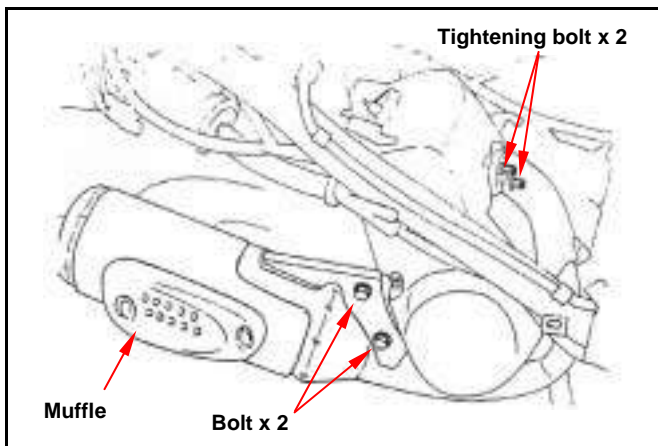
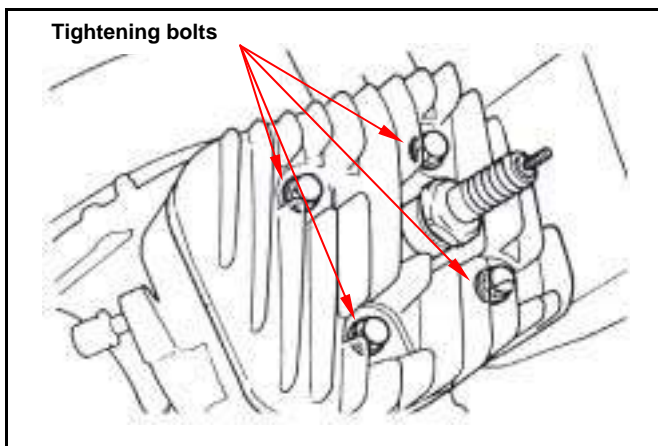

Cylinder/Piston

Cylinder Removal

Be careful to pull the cylinder up and prevent piston from damage.

Caution

Do not have pry out operation between cylinder and crankcase. Or let radiation fan be knocked seriously.

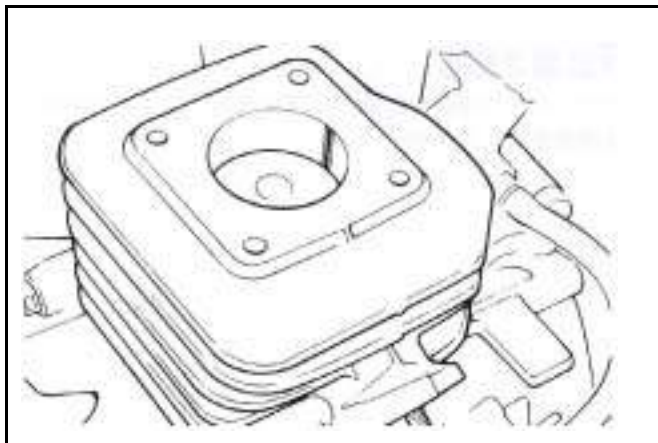

Piston Removal

Place a clean rag onto crankshaft to cover the piston.

Remove piston pin clip (one piece) and then push piston pin out the piston.

Caution

- Do not damage or scratch the piston.
- Do not apply with lateral force to connecting rod.
- Do not let piston pin snap ring falling into crankcase.

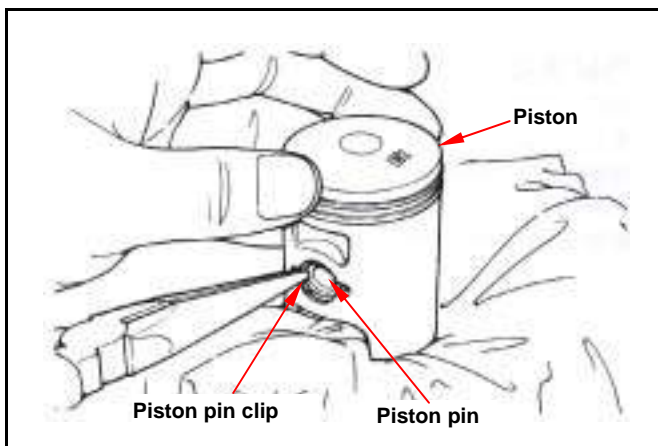

Piston Ring Removal

Caution

Pry out the opening end of each piston ring and then remove the ring from piston.

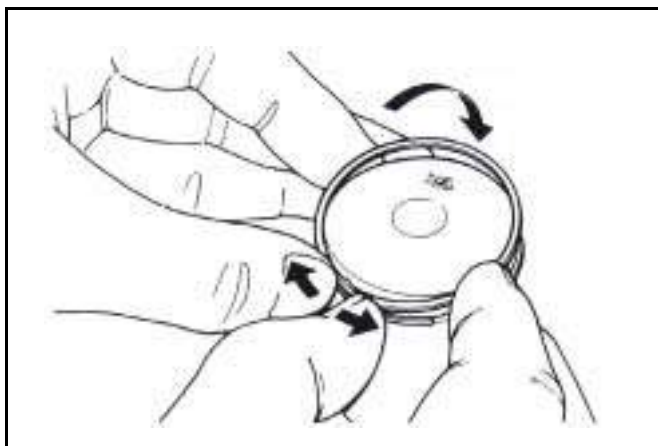

Check if cylinder and piston are worn or damaged, and then clean carbon deposit on exhaust opening area as the diagram shown.

Caution

Do not scratch both the cylinder and the piston.

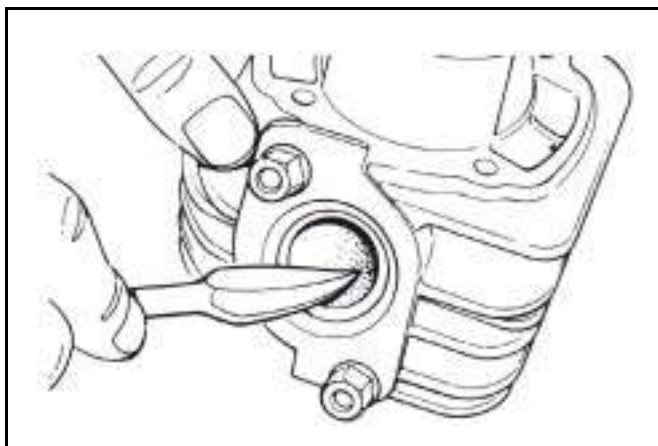

5. CYLINDER HEAD/CYLINDER/PISTON

Use a straight edge and a feeler gauge to measure the cylinder head for warp.

Service limit: 0.10 mm

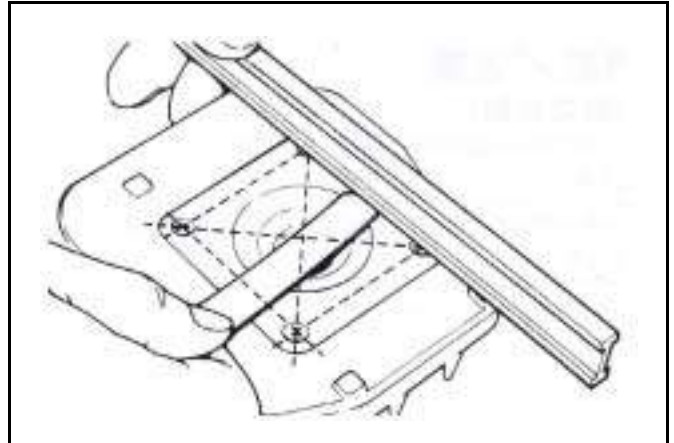

In “X” and “Y” direction, measure the cylinder for worn out as the three levels shown in the figure. With the max. value to decide cylinder wear out condition.

Service limit : 39.05mm

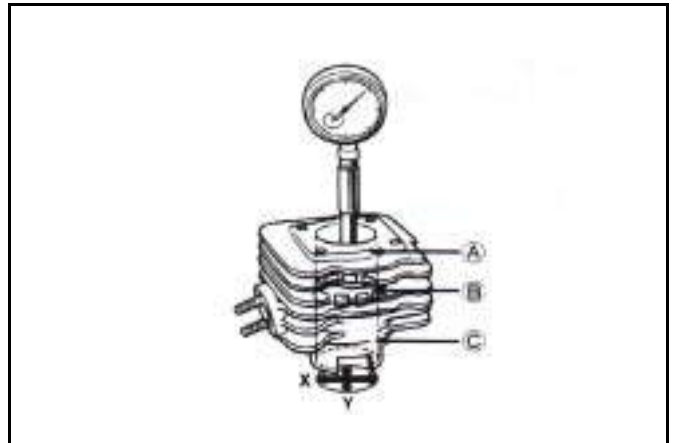

Measure the OD of piston at the 7 mm from the bottom of the piston.

Service limit : 38.935 mm

Calculate the clearance between piston and cylinder.

Service limit: 0.100 mm

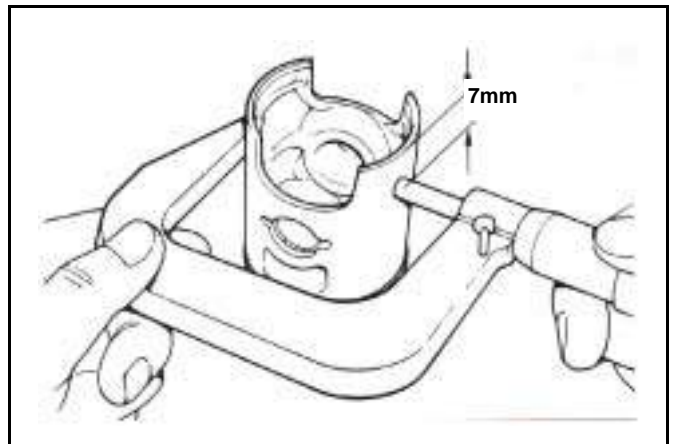

Measure the ID of piston pin hole.

Service limit : 12.030mm

Measure the OD of piston pin.

Service limit : 11.970 mm

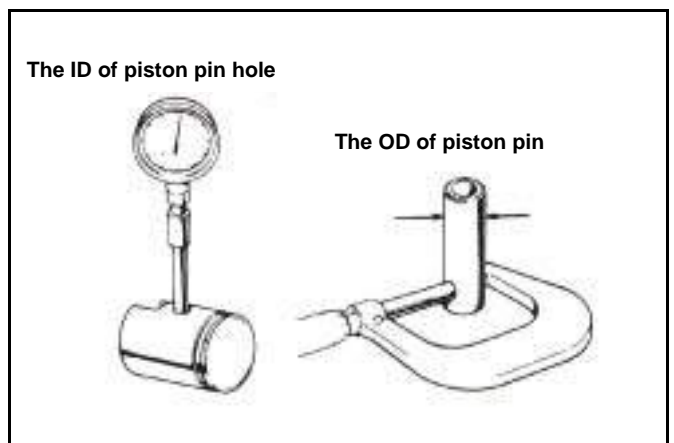

Piston Ring Inspection

Measure the end gap of each piston ring.

Service limit: 0.40 mm

Caution

With the piston, push each piston ring into cylinder correctly.

Connecting Rod Inspection

Install bearing and piston pin onto connecting rod small end, and then check its clearance.

Measure the ID of connecting rod small end.

Service limit: 17.025mm

Piston/Cylinder Installation

Install the expanding ring into the groove of 2nd ring.

Align the ring end with the lock pin in the ring groove.

Install the top ring and the 2nd ring onto the ring groove respective.

Caution

The top ring and the 2nd ring can not be changeable each other.

Push the rings into ring groove and then check rings' mating condition.

If ring could not be push in the ring groove, it means that ring groove is dirty or wrong ring groove installation.

Caution

- All rings should be installed with the marks facing up.
- All rings should be replaced at same time, and it can not be replaced one ring only.
- It should use same brand name piston ring in an engine and can not mix with other one.

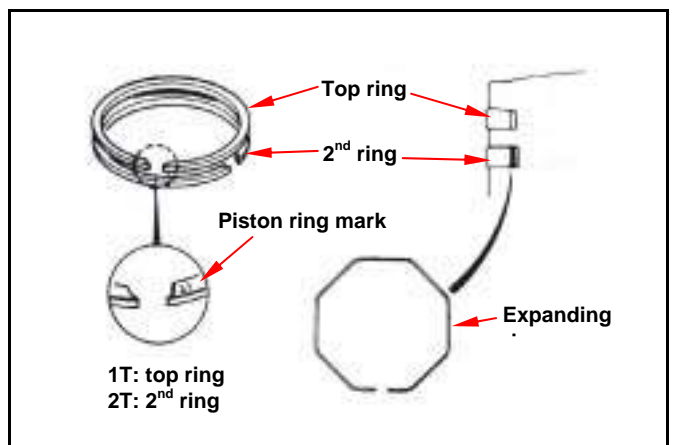
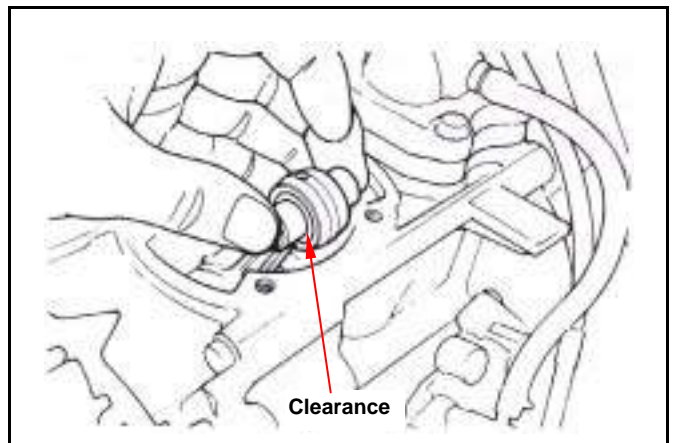
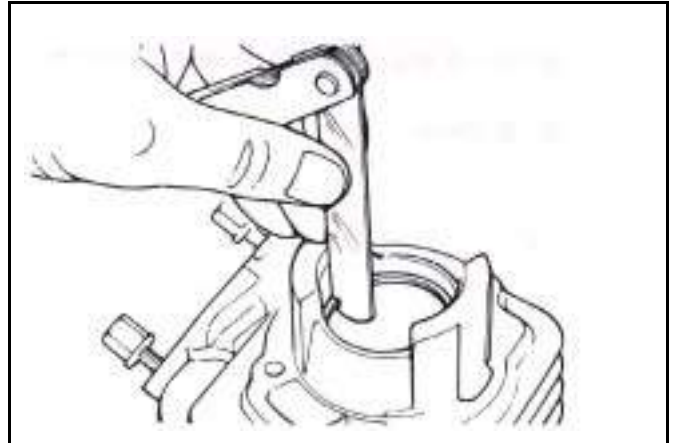

5. CYLINDER HEAD/CYLINDER/PISTON

Place a cleaning cloth onto the crankcase opening to prevent the piston pin snap ring from falling into the crankcase.

Apply with two-stroke engine oil onto needle bearing and piston pin, and then install the piston pin onto connecting rod. Install piston, and place "EX" mark of the piston toward to exhaust side. Install new piston pin snap ring.

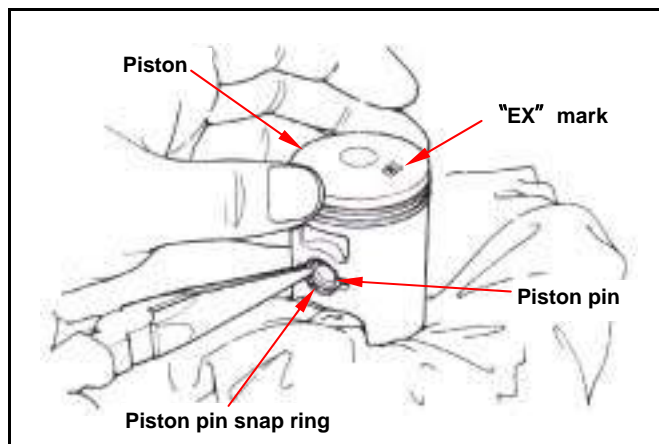

Clean all gaskets onto the interfaces of cylinder and crankcase.

Place a new gasket onto the crankcase.

Make sure that the piston ring aligns with the lock pin in piston ring groove.

Caution

Make sure that all rings in the piston ring groove can not be rotated around the lock pin to avoid to damaging the rings, piston and cylinder.

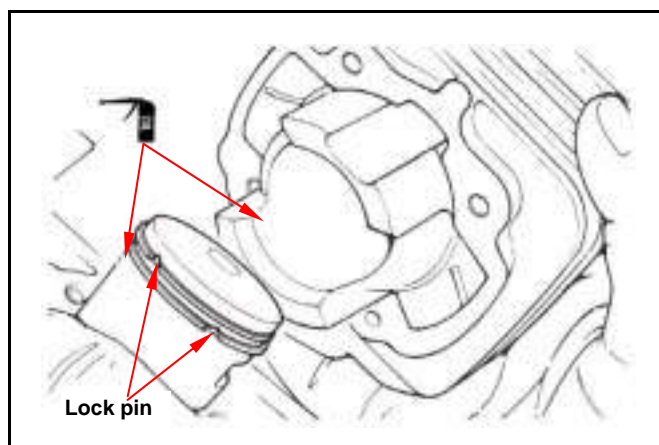

Lubricate cylinder and piston with two-stroke engine oil. Hold the piston and then install it into cylinder.

Caution

To avoid to damaging the piston and the cylinder sliding surface.

Install the cylinder head.

Maintenance Information6-2
Alternator Removal6-3

Alternator Installation 6-4

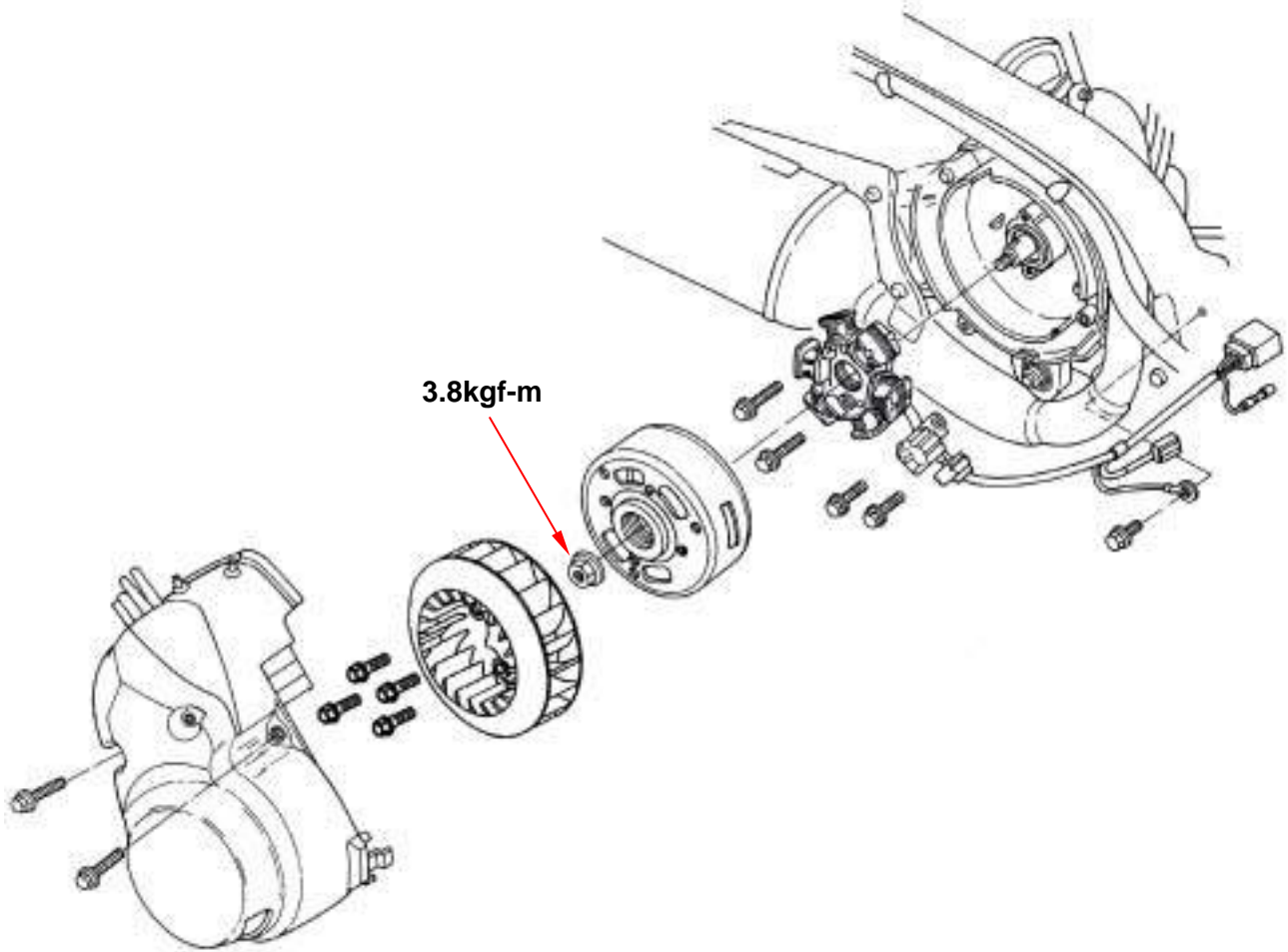

6. ALTERNATOR

Maintenance Information

Precautions in Operation

- The maintenance service of A.C. alternator can be carried out directly on the scooter.
- Please refer to Chapter 15 for the relative alternator inspection.

Torque value:

Flywheel 3.8kgf-m

Tool

General tool

Rotor puller

Universal holder

Coil resistance value for the A.C. alternator

	Y/L	Y	W	R/B	Earth
Earth	50~200Ω	0.2~0.8Ω	0.2~1.0Ω	400~800Ω	

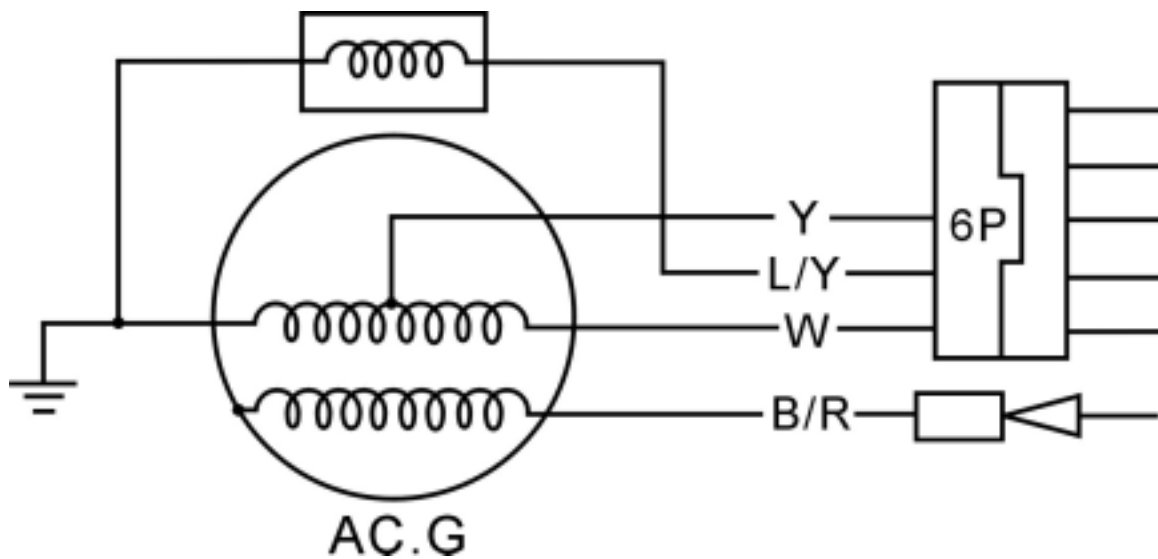

Alternator Removal

Remove the body cover.
Remove two bolts and then take out cooling fan cover.

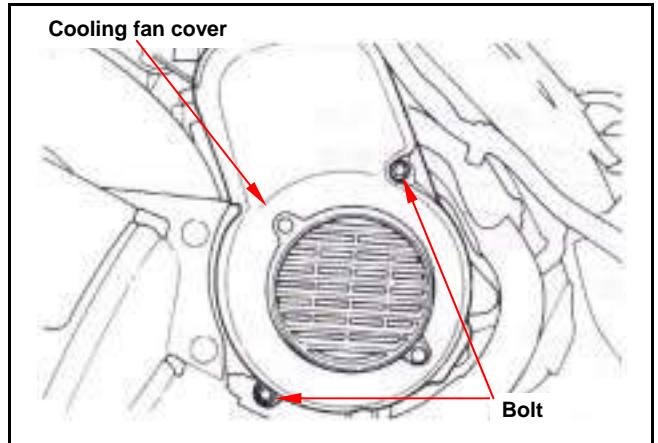

Remove four bolts, and then take out the cooling fan.

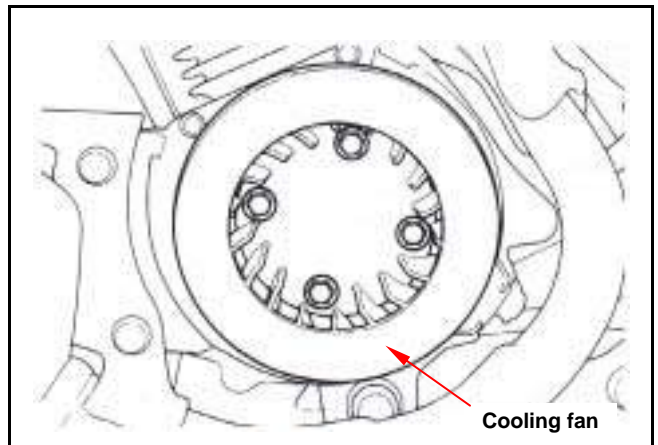

Hold flywheel with universal holder.
Support the flywheel and the remove the 10 mm nut on the flywheel.

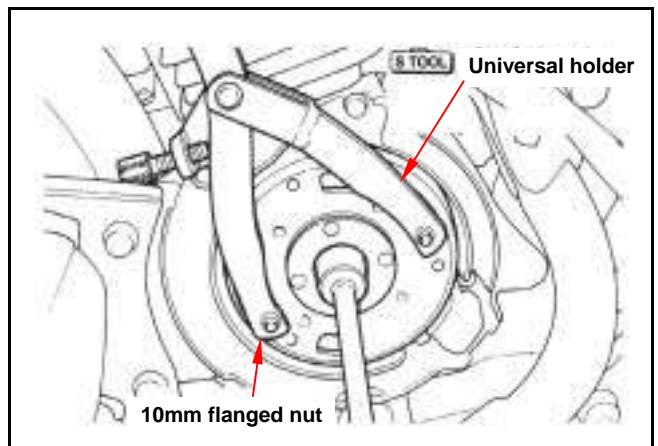

Remove the flywheel with rotor puller.

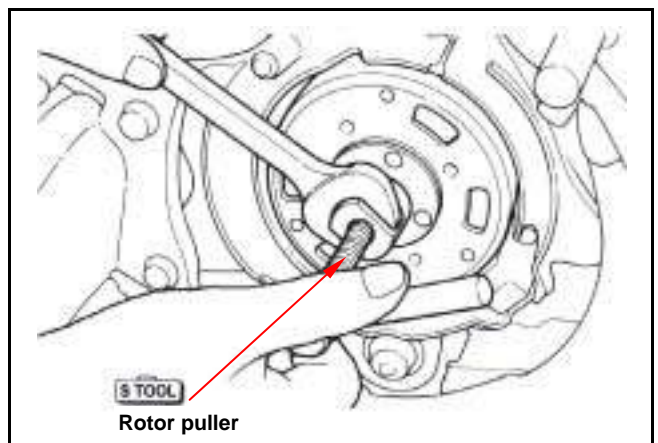

6. ALTERNATOR

Disconnect alternator wire connector and pulse generator connector.

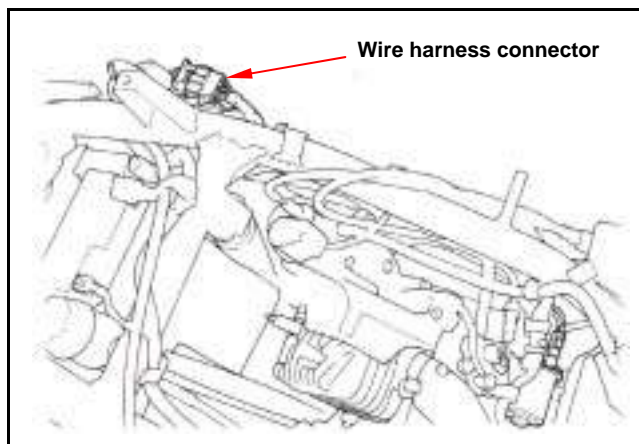

Remove the pulse generator and alternator four (4) bolts, and then take out the alternator assembly.

Caution

Care to be taken for not damaging the alternator coil.

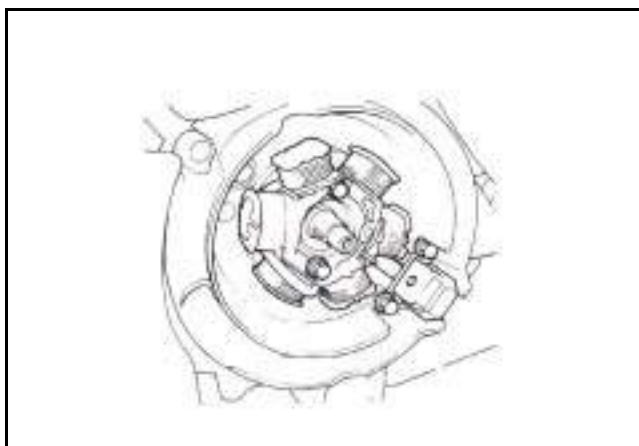

Alternator Installation

Install the alternator assembly.
Connect the alternator connector.

Caution

Connect the alternator wire harness properly and then clip the harness with clipper.

Install the woodruff key onto the crankshaft groove.

Caution

- Clean dirt and metal pieces inside the flywheel.
- Make sure that there is no foreign material inside the flywheel.

Install the flywheel

Tighten the flywheel 10 mm nut.

Torque value: 3.8kgf-m

Install the removed parts in reverse order of removal procedures.

Start engine and check its ignition timing.

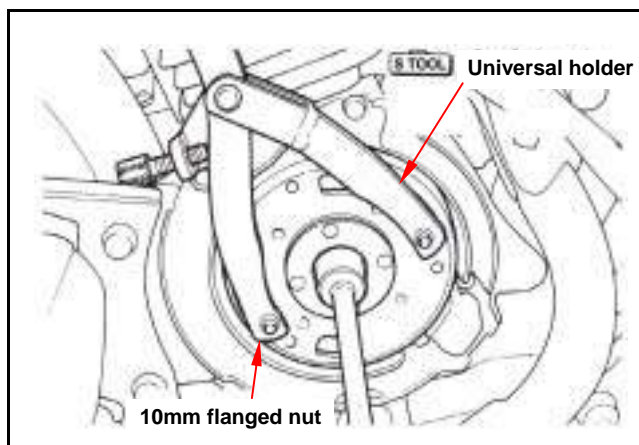



7. "V" TYPE BELT DRIVE SYSTEM/KICK-STARTER

Maintenance Information.....	7-2	Drive Belt.....	7-5
Trouble Shooting.....	7-2	Movable Driven Pulley.....	7-6
Left Crankcase Cover	7-3	Clutch/Driven Pulley.....	7-10
Reassembly of Kick Starter.....	7-4		
Installation of the Left Crankcase Cover	7-4		

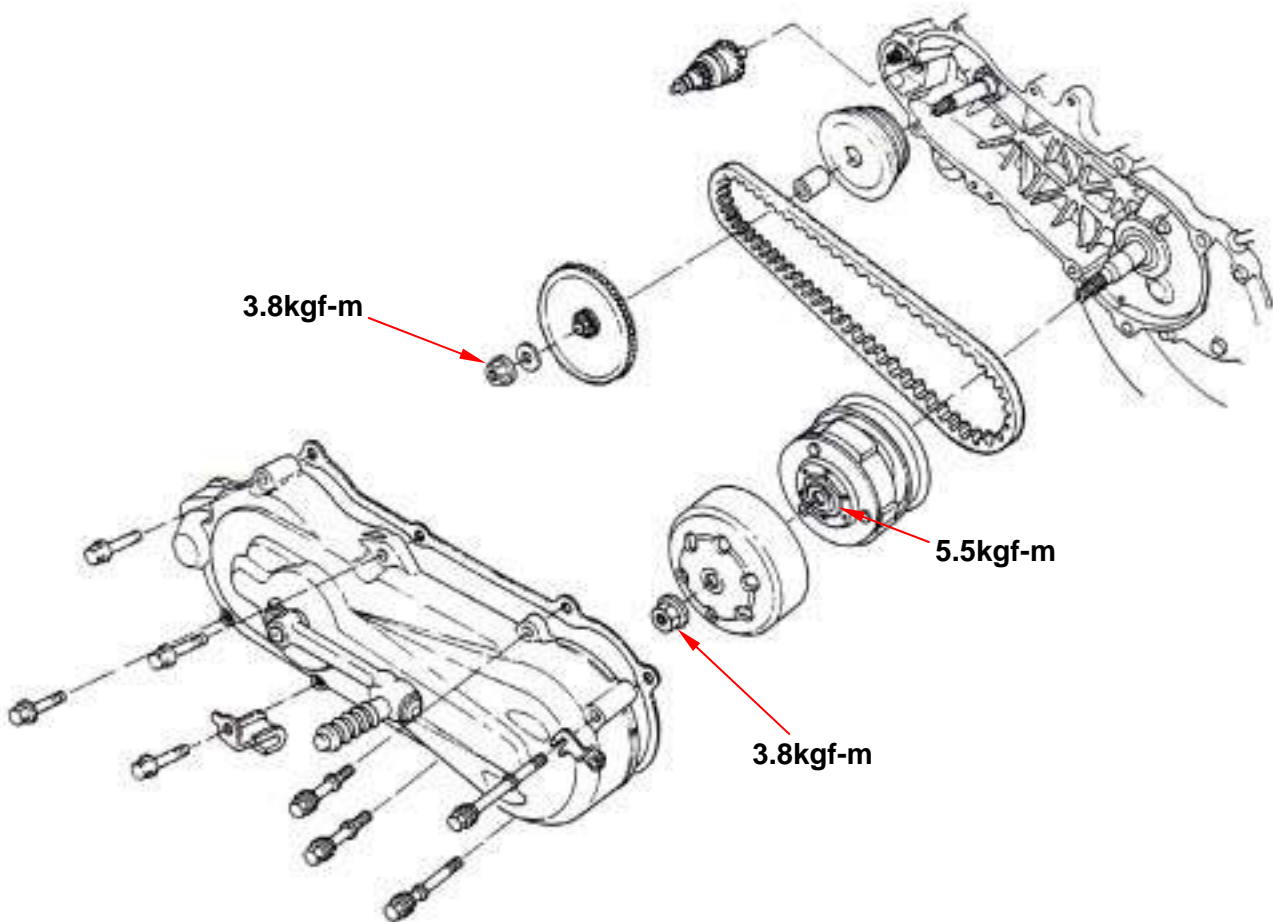

Maintenance Information

Precautions in Operation

The surfaces of drive belt and driven pulley must be free of grease.

Specification

Item	Standard value(mm)	Limit(mm)
Driving belt width	18.0	16.5
ID of movable driving pulley	20.035~20.085	20.120
OD of movable driving pulley boss	20.010~20.025	19.98
OD of weight roller	15.92~16.08	15.40
ID of clutch outer	107.0~107.2	107.5
Thickness of clutch weight	4.0~4.1	2.0
Free length of driven pulley spring	98.1	92.7
OD of driven pulley	33.965~33.985	33.94
ID of movable driven pulley	34.000~34.025	34.06

ID: Inner Diameter

OD: Outer diameter

Torque Values:

Movable drive face: **3.8kgf-m**

Driven pulley: **5.5kgf-m**

Clutch outer: **3.8kgf-m**

Special Service Tools

Clutch spring compressor

Bearing driver

Clutch nut wrench 39x41 mm

Bearing driver accessory 39x41 mm

Universal holder

Driver

Trouble Shooting

Engine can be started but motorcycle can not be moved

1. Worn drive Belt
2. Worn ramp plate
3. Worn or damaged clutch weight
4. Broken driven pulley spring

Insufficient horsepower or poor high speed performance

1. Worn drive belt
2. Insufficient spring capacity of driven pulley
3. Worn weight roller
4. Driven pulley operation un-smoothly

Shudder or misfire when drive

1. Broken clutch weight
2. Worn clutch weight

Left Crankcase Cover

Left crankcase cover removal

- Remove left body side cover.
- Remove air cleaner.
- Remove kick start arm.
- Remove left crankcase cover.

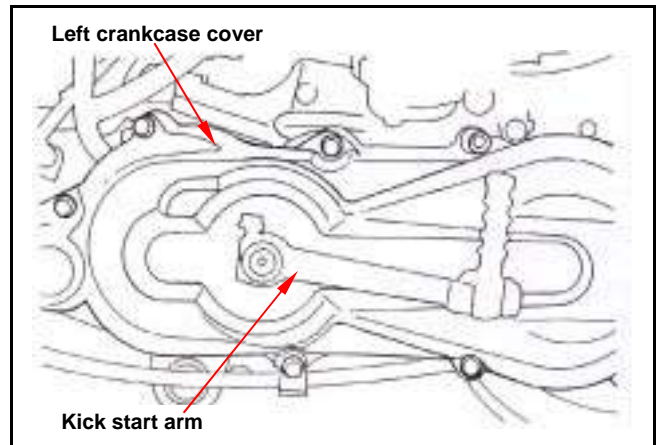

Disassembly of Kick Starter

- Remove snap clip and thrust washer from left crankcase cover.
- Install kick start arm, rotate the lever slightly and then remove driven gear and washer.
- Remove the kick starter arm, kick starter spindle, and return spring as well as socket.

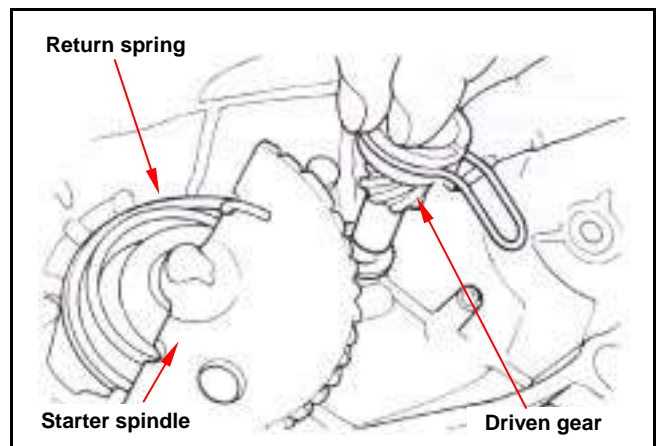

Inspection of kick Starter

Check if starter spindle, driven gear for wear or damage.

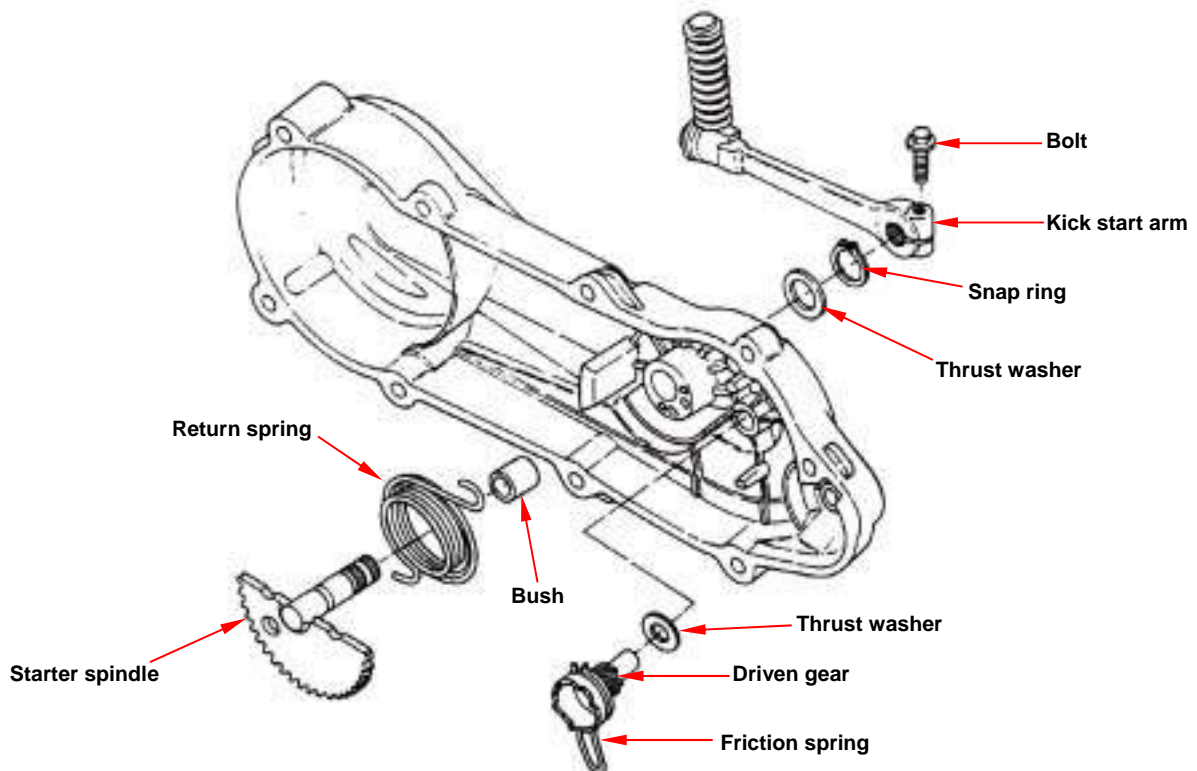

7. "V" TYPE BELT DRIVE SYSTEM/KICK-STARTER

Reassembly of Kick Starter

Install bush, return spring and starter spindle as diagram shown.

Install thrust washer and snap clip onto starter spindle.

Install Kick starter lever temporary.

Slightly rotate the lever and then align driven gear with width-tooth on the starter spindle.

Install the friction spring of drive gear onto convex part of the cover.

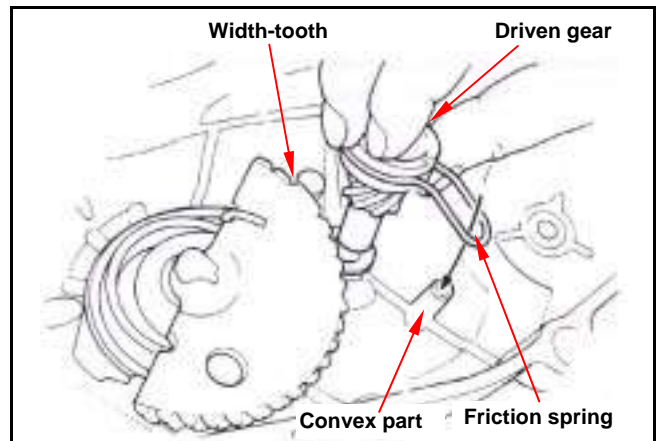
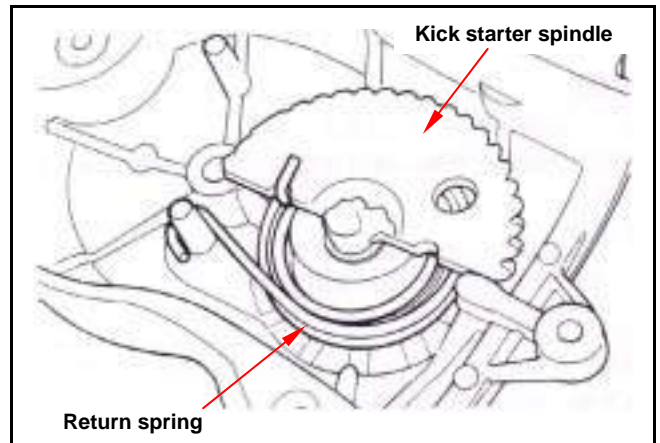

Installation of the Left Crankcase Cover

Install the dowel pin and gasket.

Install the left crankcase cover.

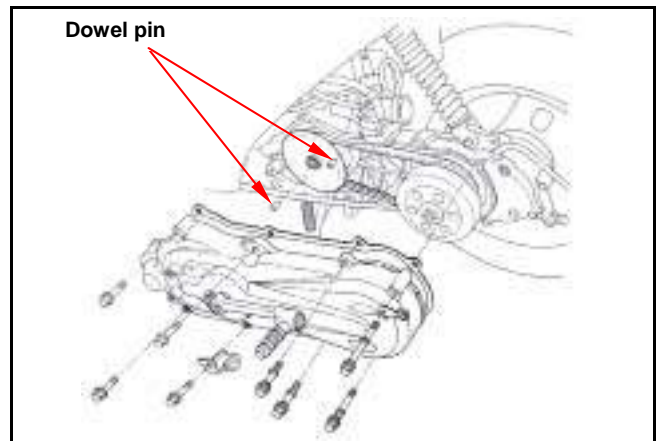

Install kick start arm.

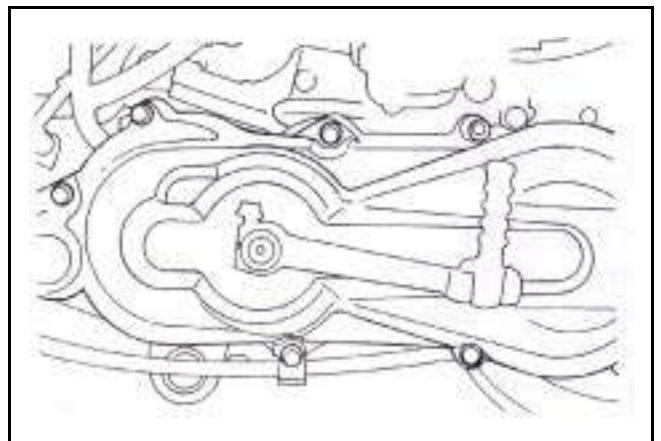

Drive Belt

Removal

Remove left crankcase cover.
Hold clutch outer with universal holder, and remove nut and clutch outer.

Caution

- Using special tools for tightening or loosening the nut.
- Fixed rear wheel or rear brake will damage reduction gear system.

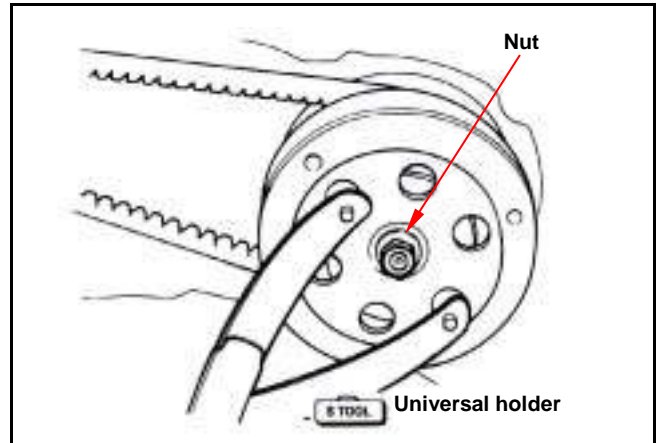

Push the drive belt into belt groove as diagram shown so that the belt can be loosened, and then remove the driven pulley.
Remove driven pulley/clutch. Do not remove drive belt.
Remove the drive belt from the groove of driven pulley.

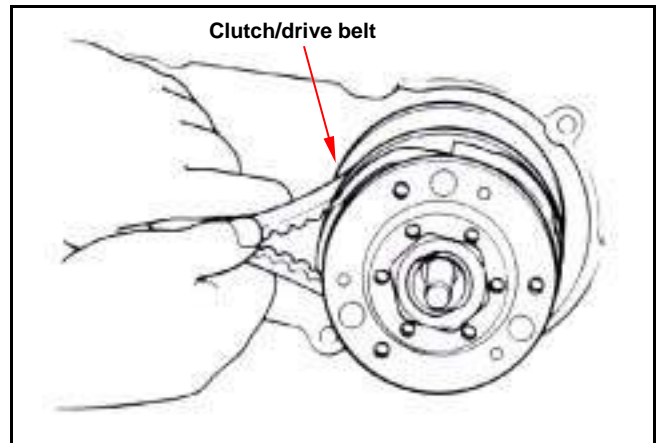

Inspection

Check the drive belt for crack or wear. Replace it if necessary.
Measure the width of drive belt as diagram shown.

Service Limit: 16.5 mm

Replace the belt if exceeds the service limit.

Caution

- Using the genuine parts for replacement
- The surfaces of drive belt or pulley must be free of grease.
- Clean up all grease or dirt before installation.

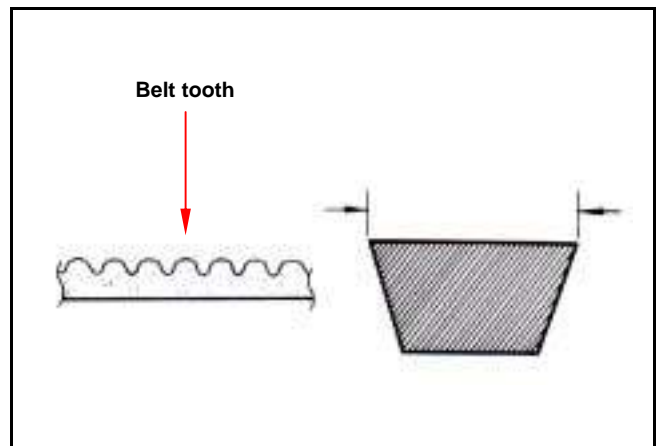

Installation

Caution

- Pull out driven pulley to avoid it closing.

Install drive belt onto driven pulley.

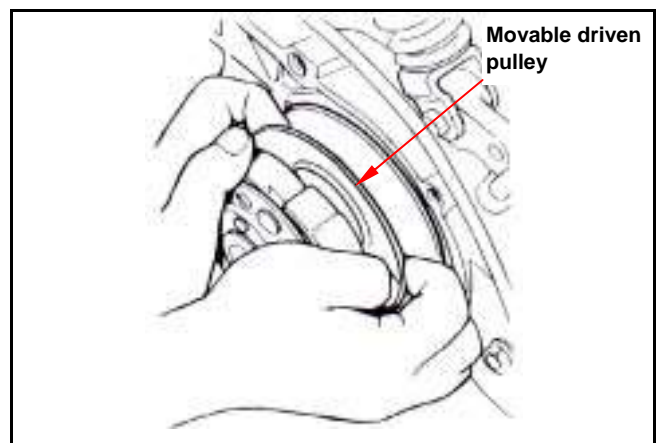

7. "V" TYPE BELT DRIVE SYSTEM/KICK-STARTER



Install the driven pulley that has installed the belt onto drive shaft.

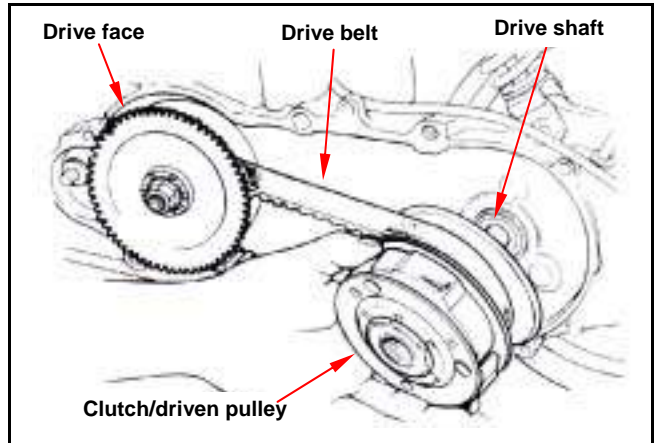

Install the clutch with universal holder, and then tighten nut to specified torque value.

Torque value: 3.8kgf-m

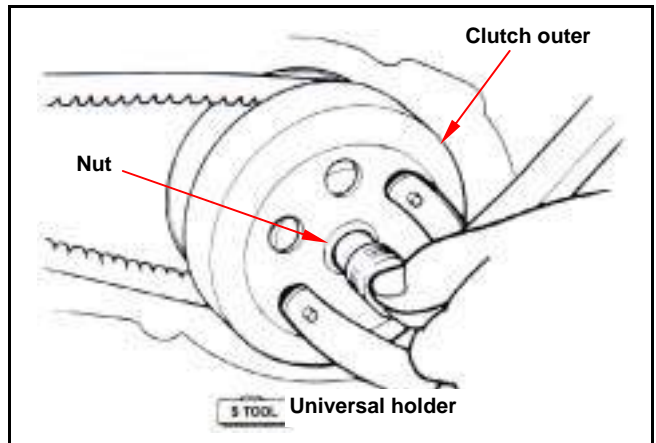

Movable Drive Face

Removal

Remove left crankcase cover.
Hold generator flywheel with universal holder, and then remove drive face nut.

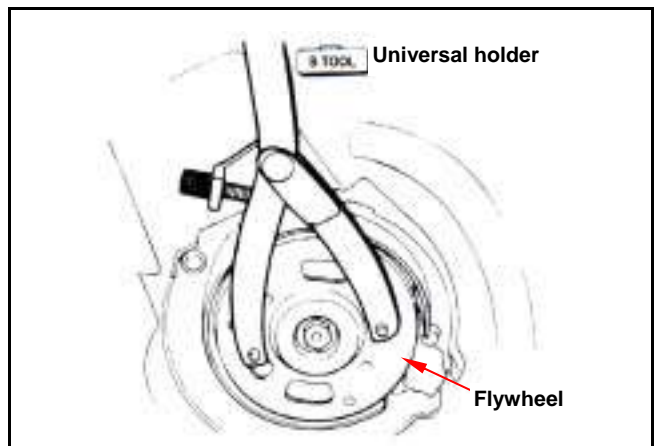

Remove drive face.

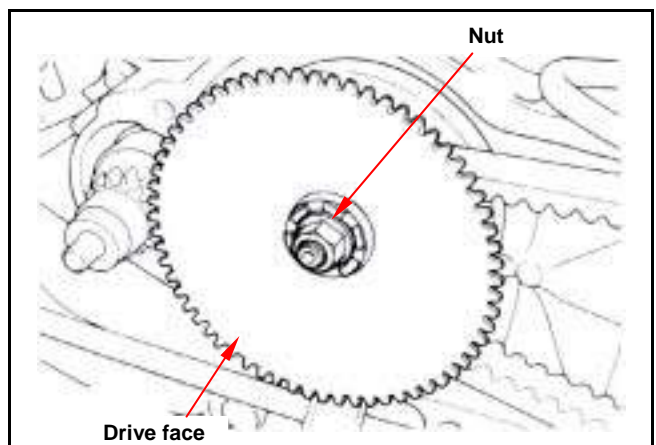

Removal

Remove movable drive face set and drive belt from crankshaft.

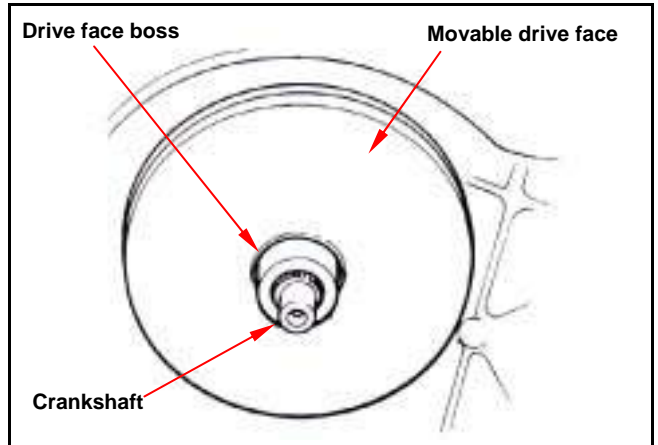

Remove ramp plate.

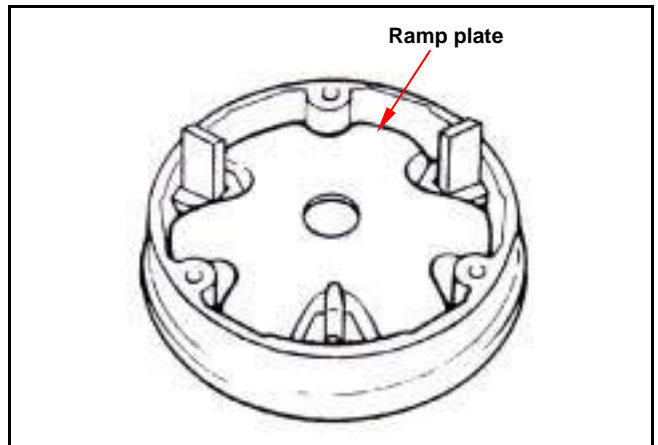

Remove weight rollers from movable face.

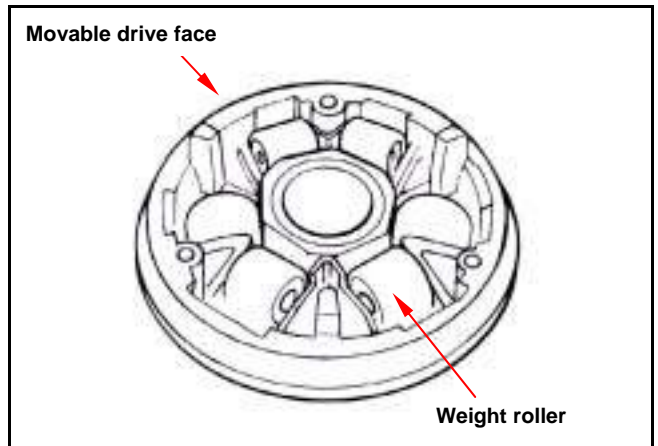

Inspection

The weight roller is to press movable driven face by means of centrifuge force. Thus, if weight rollers are worn out or damage, the centrifuge force will be affected.

Check if rollers are wear out or damage.

Replace it if necessary.

Measure each roller's outer diameter. Replace it if exceed the service limit.

Service limit: 15.40 mm

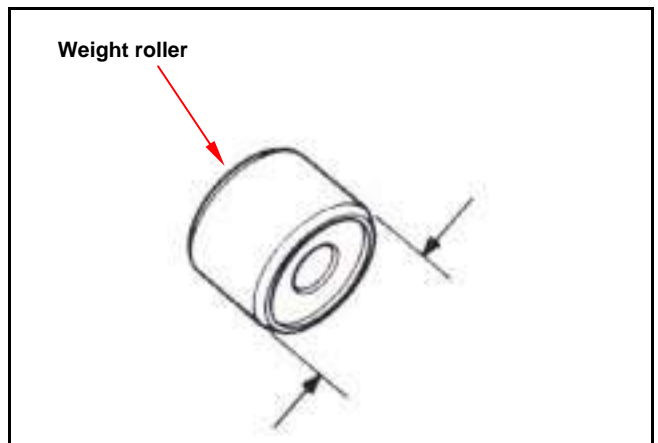

7. "V" TYPE BELT DRIVE SYSTEM/KICK-STARTER

Check if movable drive face boss is worn or damage and replace it if necessary.
 Measure the outer diameter of drive face boss, and replace it if it exceed service limit.

Service limit: 19.98 mm

Measure the inner diameter of drive face, and replace it if it exceed service limit.

Service limit: 20.120 mm

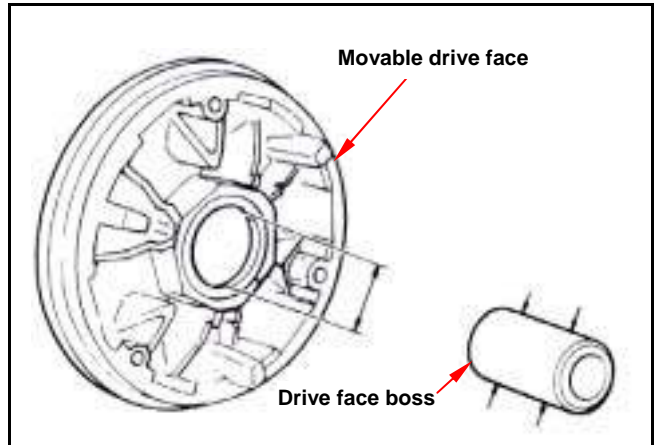

Reassembly / Installation

Install weight rollers.

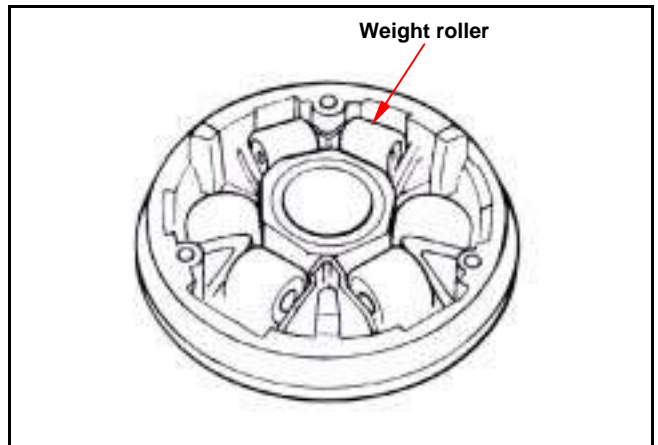

Install ramp plate.

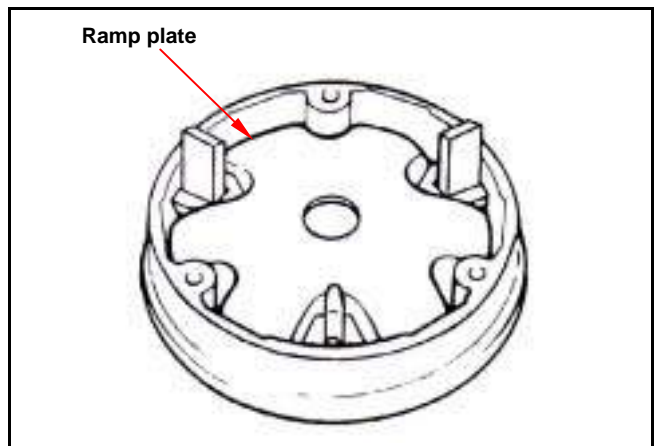

Apply with grease 4~5g to inside of movable drive face, and install drive face boss.

Caution

- The drive face has to be free of grease. Clean it with cleaning solvent.

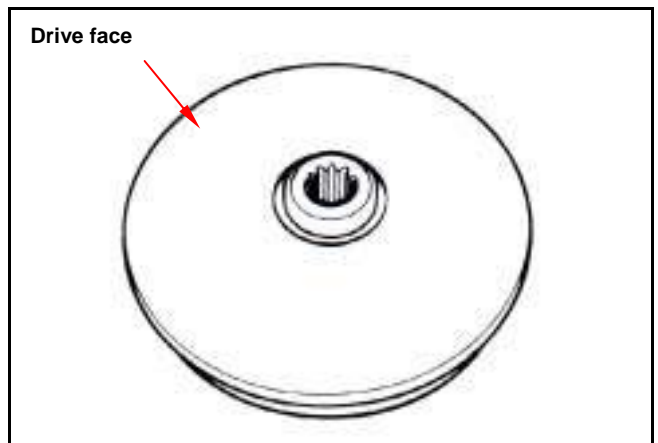

Install movable drive face assembly onto crankshaft.

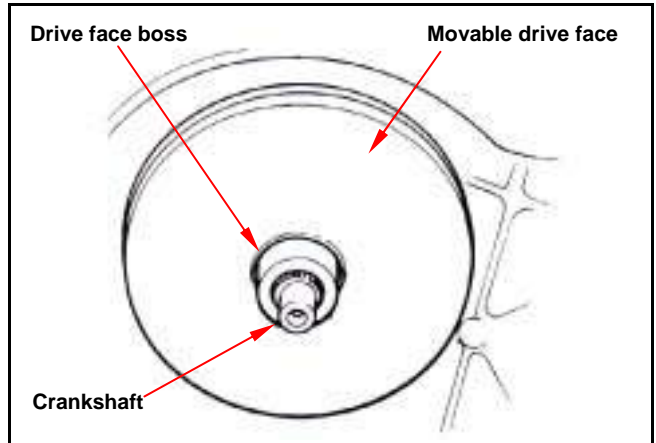

Drive Face Installation

Press drive belt into pulley groove, and then pull the belt on to crank shaft.

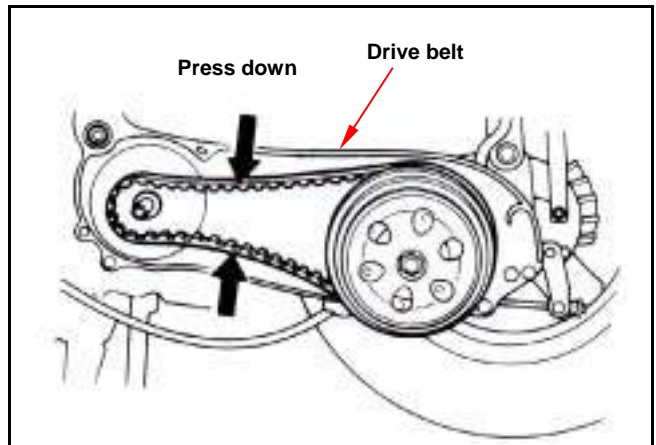

Install drive face, washer and nut.

⚠ Caution

- Make sure that two sides of drive face have to be free of grease. Clean it with cleaning solvent.

Hold flywheel with universal holder.

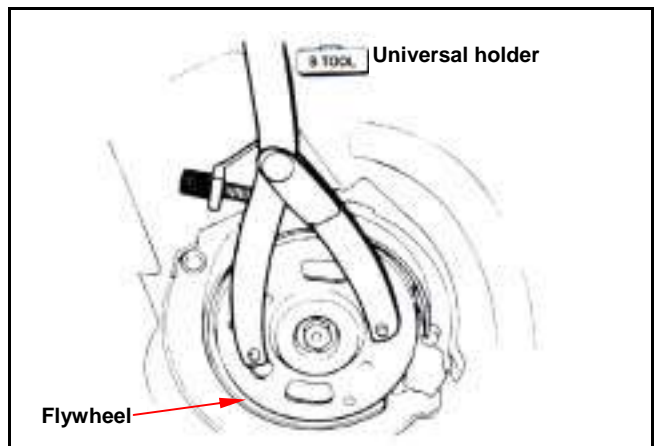

Tighten nut to specified torque.

Torque value: 3.8kgf-m

Install left crankcase cover.

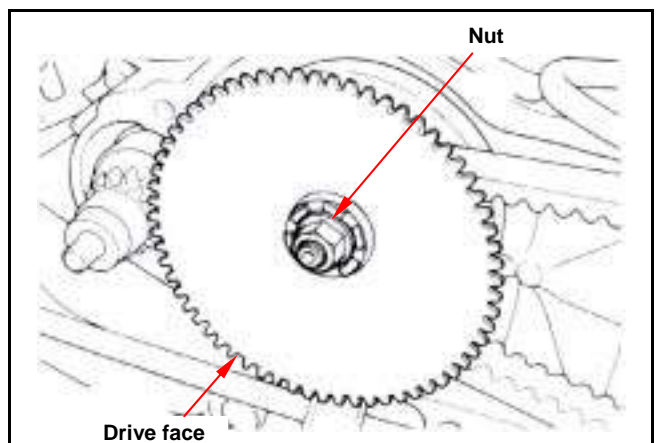

Clutch/Driven Pulley

Disassembly

Remove drive belt and clutch/driven pulley. Install clutch spring compressor onto the pulley assembly, and operate the compressor to let nut be installed more easily.

⚠ Caution

- Do not press the compressor too much.

Hold the clutch spring compressor onto bench vise, and then remove mounting nut with clutch nut wrench.

Release the clutch spring compressor and remove clutch and spring from driven pulley. Remove socket from sliding pulley.

Remove guide pin, guide pin roller, and driven pulley, and then remove O-ring & oil seal seat from sliding pulley.

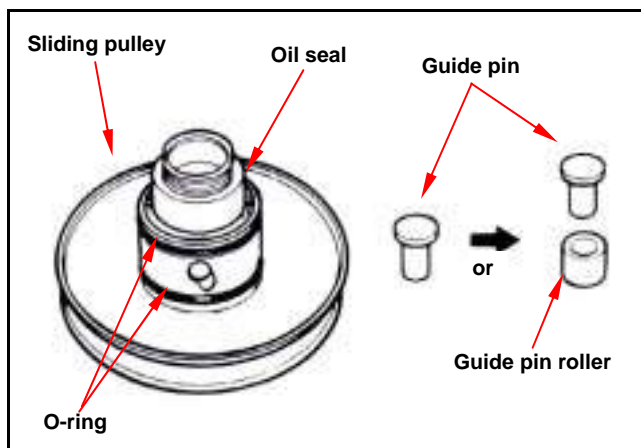
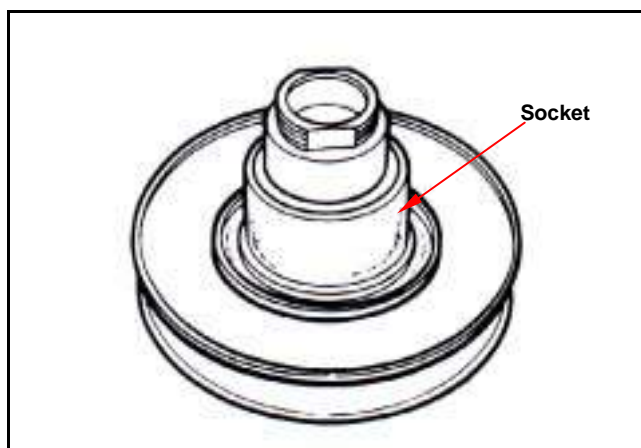
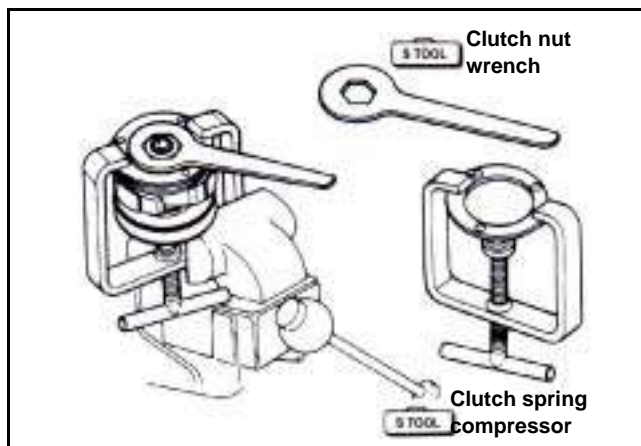

Inspection

Clutch outer

Measure the inner diameter of clutch outer friction face. Replace clutch outer if exceed service limit.

Service limit: 107.5 mm

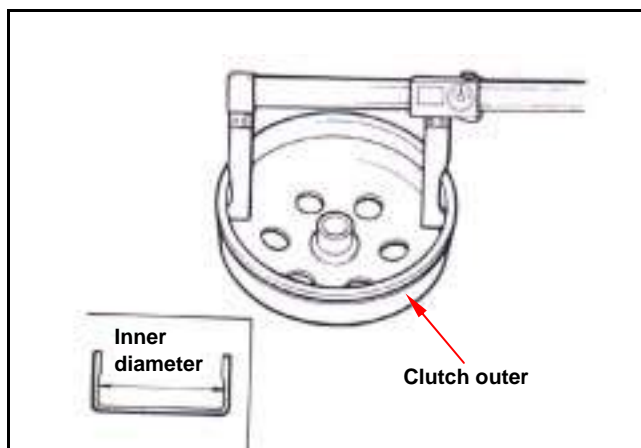

Clutch weight

Measure each clutch weight thickness. Replace it if exceeds service limit.

Service limit: 2.0 mm

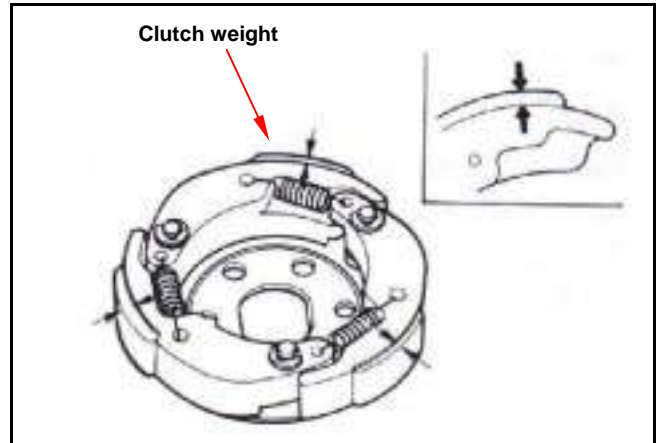

Driven pulley spring

Measure the length of driven pulley spring. Replace it if exceeds service limit.

Service limit: 92.7 mm

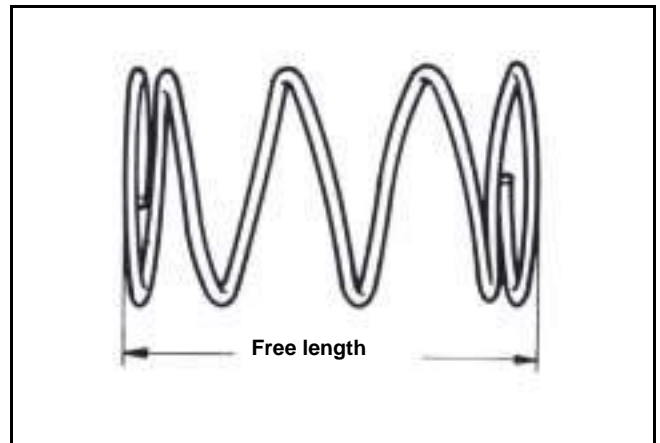

Driven pulley

Check following items:

- If both surfaces are damage or wear.
- If guide pin groove is damage or wear.

Replace damaged or worn components.

Measure the outer diameter of driven pulley and the inner diameter of sliding pulley. Replace it if exceeds service limit.

Service limit: Outer diameter 33.94 mm

Inner diameter 34.06 mm

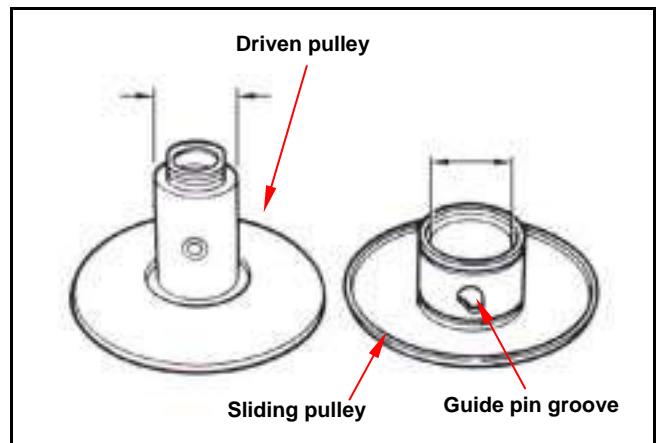

Driven Pulley Bearing Inspection

Check if the inner bearing oil seal is damage.

Replace it if necessary.

Check if needle bearing is damage or too big clearance. Replace it if necessary.

Rotate the inside of inner bearing with fingers to check if the bearing rotation is in smooth and silent. Check if the bearing outer parts are closed and fixed. Replace it if necessary.

⚠ Caution

- Some of models are equipped with two ball bearings.

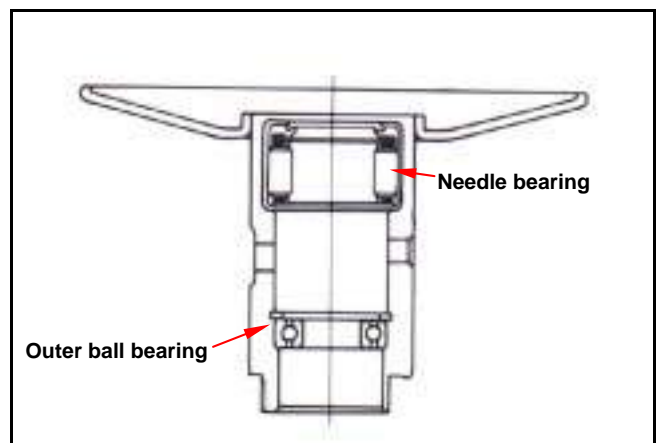

Clutch Block Replacement

Remove clip and washer, and then remove clutch weight and spring from drive plate.

Caution

- Some of models are equipped with one mounting plate instead of 3 snap clips.

Check if spring is damage or insufficient elasticity.

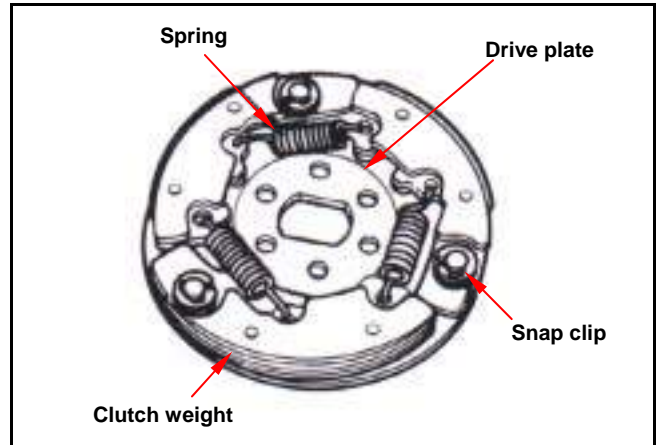

Check if shock absorption rubber is damage or deformation. Replace it if necessary. Apply with grease onto lock pins.

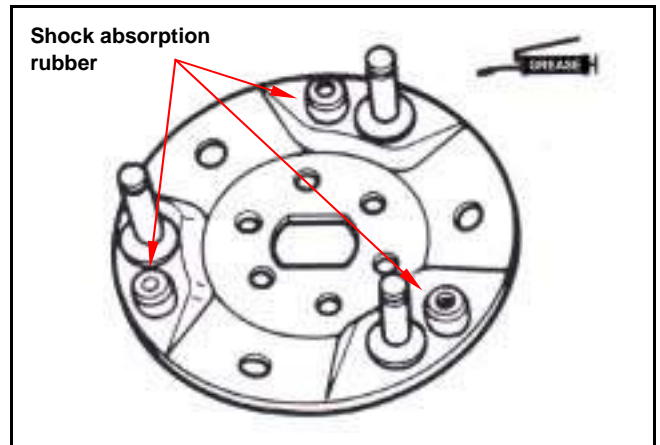

Install new clutch weight onto lock pin and then push to specific location. Apply with grease onto lock pins. But, the clutch weight should not be greased. If so, replace it.

Caution

- Grease or lubricant will damage the clutch weight and affect the weight's connection capacity.

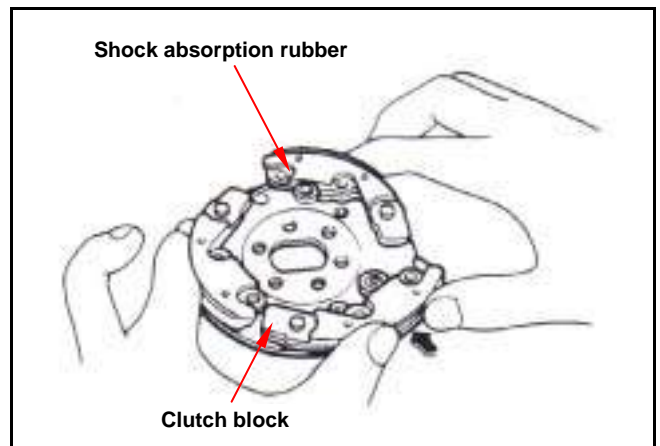

Install the spring into groove with pliers.

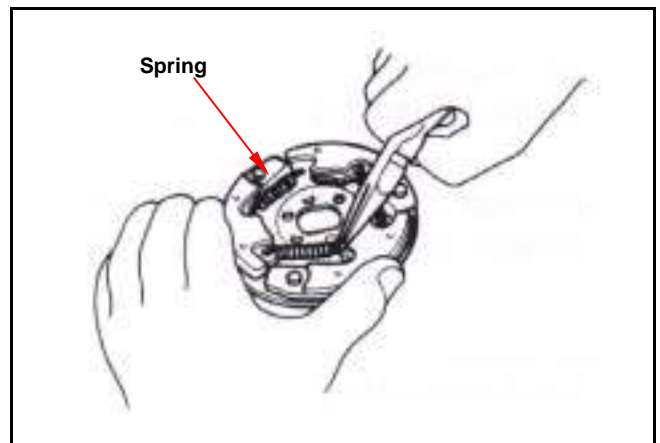

Install snap clip and mounting plate onto lock pin.

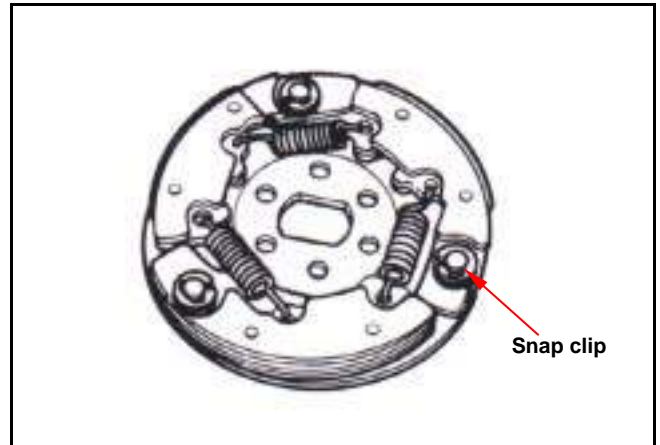

Replacement of Driven Pulley Bearing

Remove inner bearing.

Caution

- If the inner bearing equipped with oil seal on side in the driven pulley, then remove the oil seal firstly.
- If the pulley equipped with ball bearing, it has to remove snap clip and then the bearing.

Remove snap clip and then push bearing forward to other side of inner bearing.

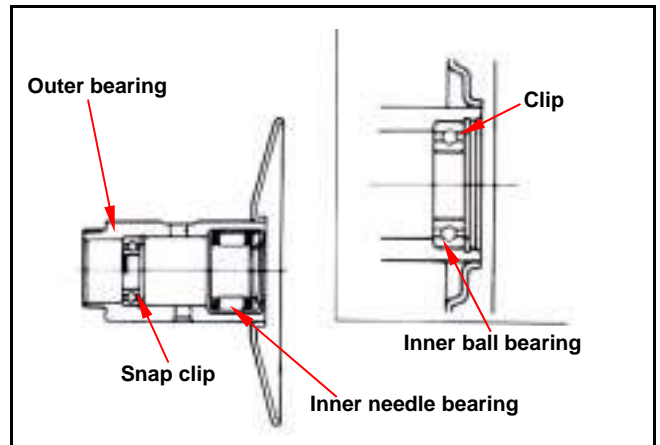

Place new bearing onto proper position and its sealing end should be forwarded to outside.

Apply with specified grease.

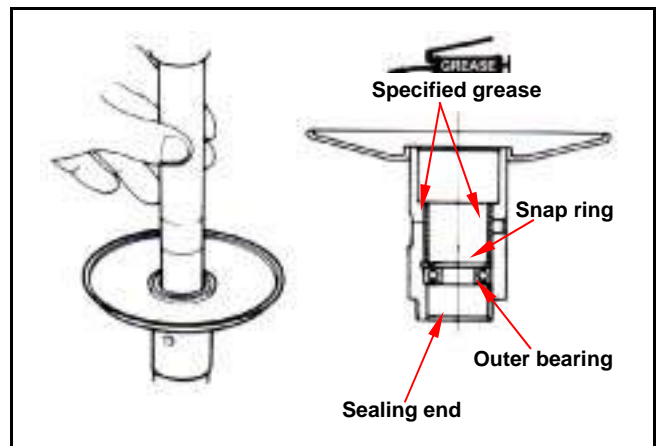

Install new inner bearing.

Caution

- Its sealing end should be forwarded to outside as bearing installation.
- Install needle bearing with hydraulic presser. Install ball bearing by means of hydraulic presser or driver.

Install snap clip into the groove of drive face. Align oil seal lip with bearing, and then install the new oil seal (if necessary).

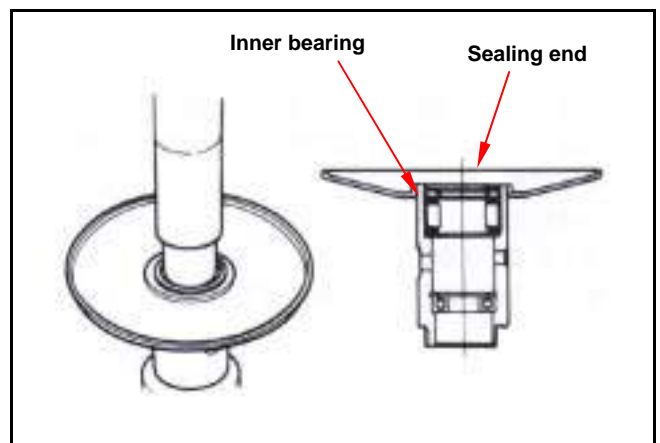

Installation of Clutch/Driven Pulley

Assembly

Install new oil seal and O-ring onto sliding pulley.
Apply with specified grease to lubricate the inside of sliding pulley.

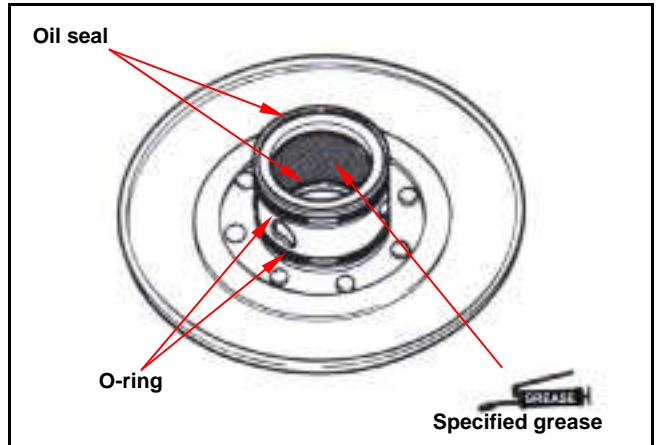

Install sliding pulley onto driven pulley.
Install guide pin and guide pin roller.

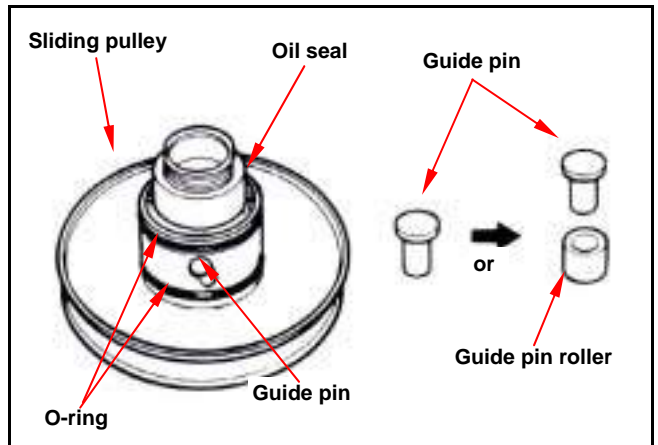

Install socket.

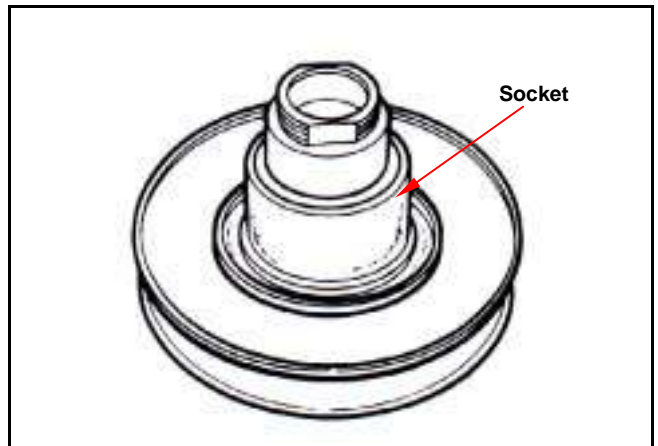

Install driven pulley, spring and clutch into clutch spring compressor, and press down the assembly by turning manual lever until mounting nut that can be installed.

Hold the compressor by bench vise and tighten the mounting nut to specified torque with clutch nut wrench.

Remove the clutch spring compressor.

Torque value: 5.0~6.0kgf-m

Install clutch/driven pulley and drive belt onto drive shaft.

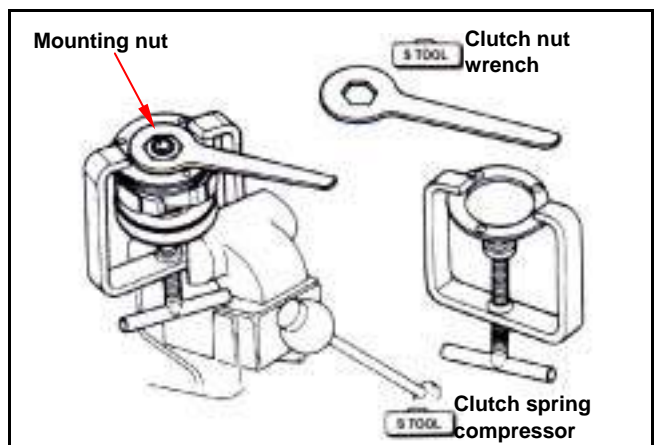



8. FINAL DRIVING MECHANISM

Maintenance Information 8-2	Inspection of Final Driving Mechanism 8-4
Troubleshooting 8-2	Bearing Replacement 8-4
Disassembly of Final Driving Mechanism 8-3	Re-Assembly of Final Driving Mechanism 8-4

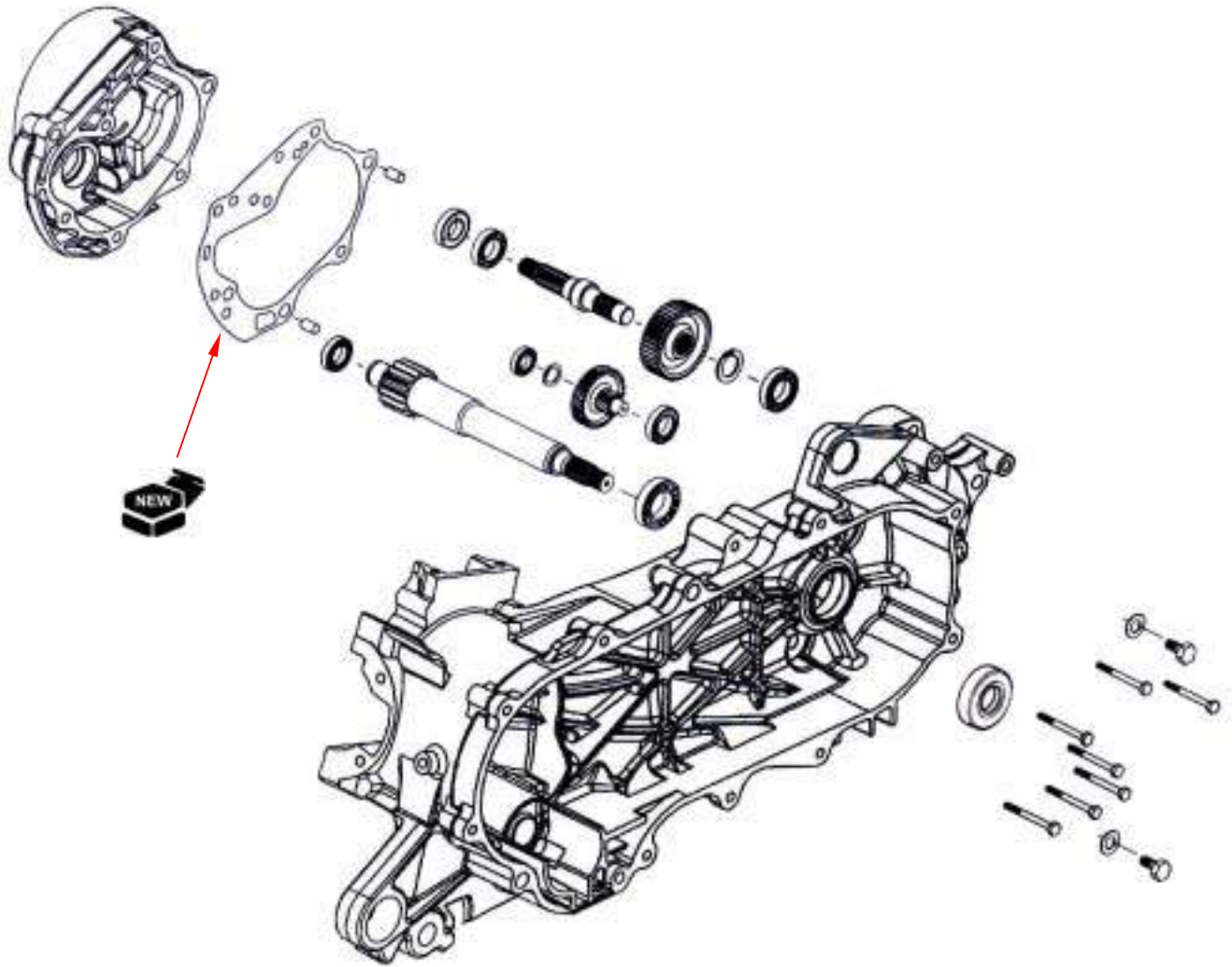

8. FINAL DRIVING MECHANISM

Maintenance Information

Limited usage of gear oil : gear oil #140

Recommended oil : Bramax serial oil.

Oil quantity : 100 c.c. (90 c.c. as replacement)

Special tools:

Inner type bearing puller (SYM-6204020)

Outer type bearing puller (SYM-6204010)

Final shaft oil seal installer (SYM-9125500)

Drive shaft oil seal installer (SYM-9120200)

Bearing driver 6204 (SYM-9110400)

Bearing driver 6201 (SYM-9610001)

Bearing driver 6203/6004UZ (SYM-9620000)

L. crank puller (SYM-1130000-L)

L. crank shaft install bush (SYM-1130010)

Troubleshooting

Trouble Diagnosis

Engine can be started but scooter can not be moved.

1. Damaged drive gear
2. Burnt out or seized drive gear

Noise

1. Seized, worn or damage gear
2. Worn or loose bearing

Gear oil leaks

1. Excessive gear oil.
2. Worn or damage oil seal

Disassembly of Final Driving Mechanism

Remove driven pulley

Drain gear oil out from gearbox.

Remove rear wheel.

Remove gearbox cover mounting bolts from the clutch side and then remove the cover from the rear wheel side.

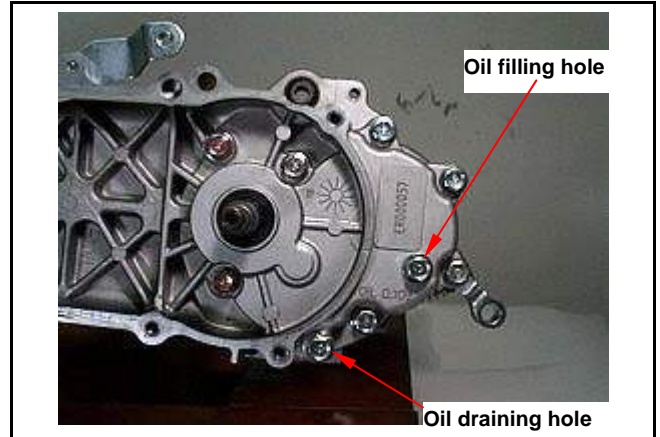

Remove final gear, final shaft and counter gear, counter shaft.

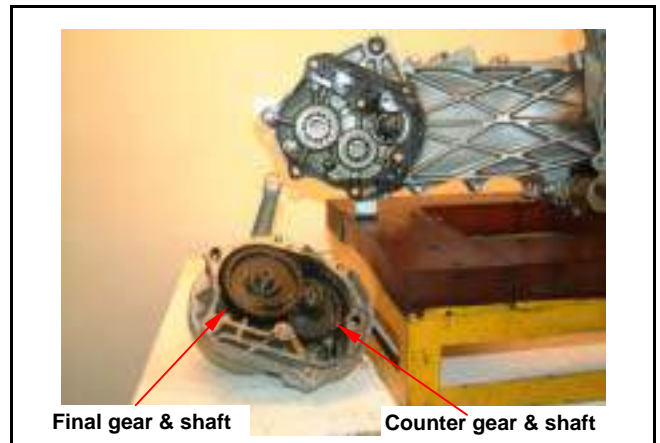

Remove the drive shaft from left crankcase.

⚠ Caution

- The bearing must be replaced when removing the drive shaft.

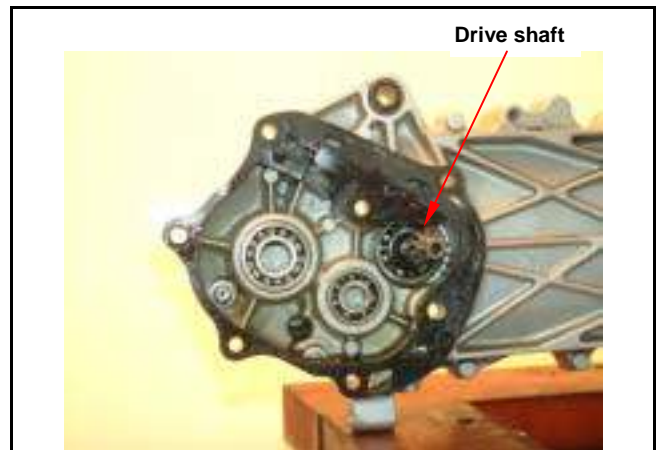

Remove drive shaft oil seal and bearing from left crankcase.

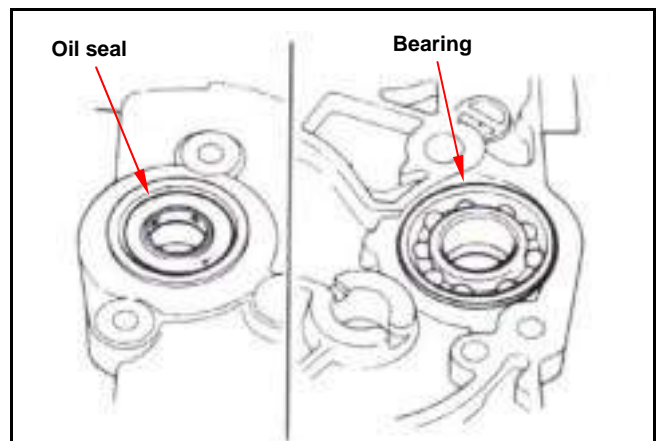

8. FINAL DRIVING MECHANISM

Inspection of Final Driving Mechanism

Check if the drive shaft, counter shaft and final gear shaft are worn or damage.

Check if the gear box cover bearing, oil seal and the inner diameter of counter shaft are worn or damage.

Check if the left crankcase cover bearing, oil seal and the inner diameter of countershaft are worn or damage.

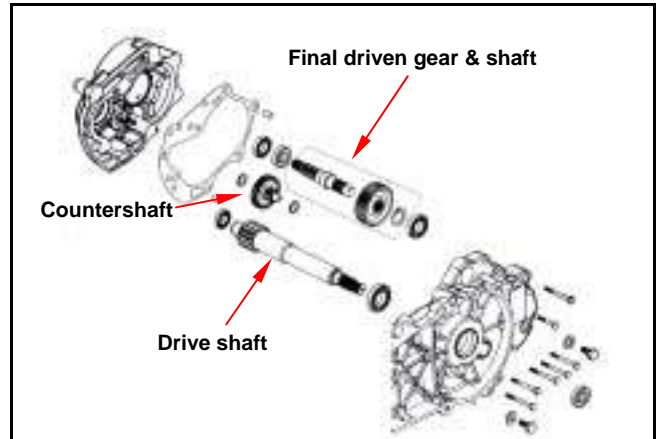

Bearing Replacement

⚠ Caution

- Never install used bearings. Once bearing removed, it has to be replaced with new one.

Remove gear box bearing from left crankcase and gear box cover using following tools:

Special tool:

Inner type bearing puller



Re-Assembly of Final Driving Mechanism

Re-assemble the gearbox cover and left crankcase with special tools:

Special tool:

Gear Box Cover

Final shaft bearing:

Bearing driver 6203/6004UZ (SYM-9620000)

Bearing driver 6201 (SYM-9610001)

Final shaft oil seal installer (SYM-9125500)

Left Crankcase

Drive shaft bearing:

Bearing driver 6203/6004UZ (SYM-9620000)

Bearing driver 6201 (SYM-9610001)

L. crank puller (SYM-1130000-L)

L. crank shaft install bush (SYM-1130010)

Drive shaft oil seal installer (SYM-9120200)

With the special service tools to install drive shaft by through the bearing.

Install a new drive shaft oil seal.

Install a new final shaft oil seal.

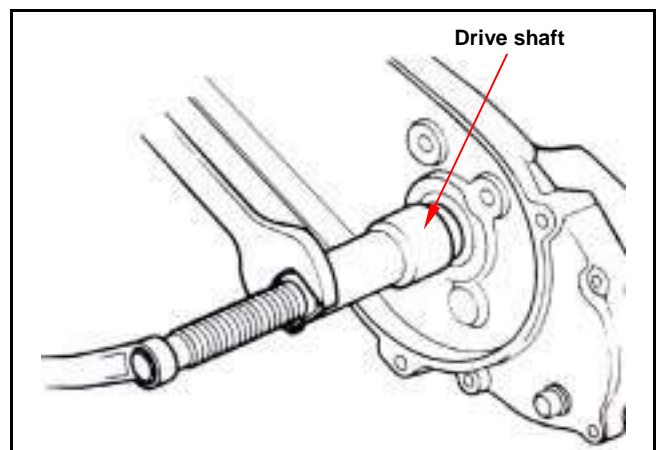
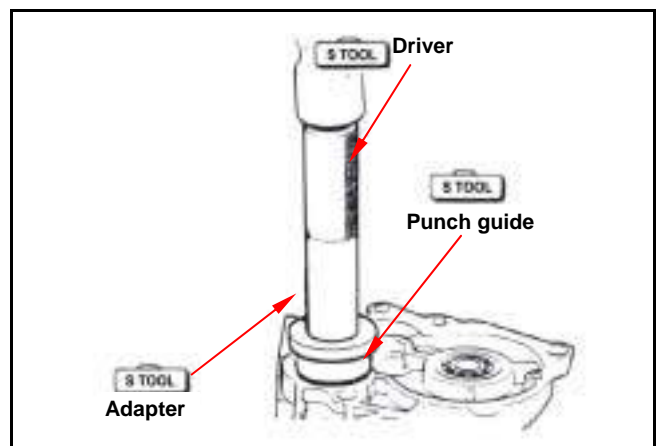

Install countershaft, final driven gear and thrust washer.

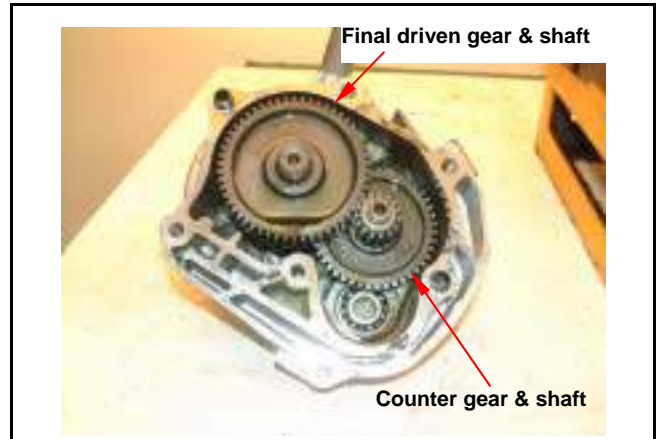

Install new gasket and lock pin.



Install gearbox cover.
 Install clutch/driven pulley assembly.
 Install driven pulley, drive belt, and left crankcase side cover.
 Install body cover.
 Install rear wheel.
 Fill out specified oil quantity into gearbox.



8. FINAL DRIVING MECHANISM



Notes:

Maintenance Information 9-2	Crankshaft Removal.....9-3
Troubleshooting 9-2	Crankshaft Inspection.....9-4
Crankcase Disassembly 9-3	Crankcase Installation9-5

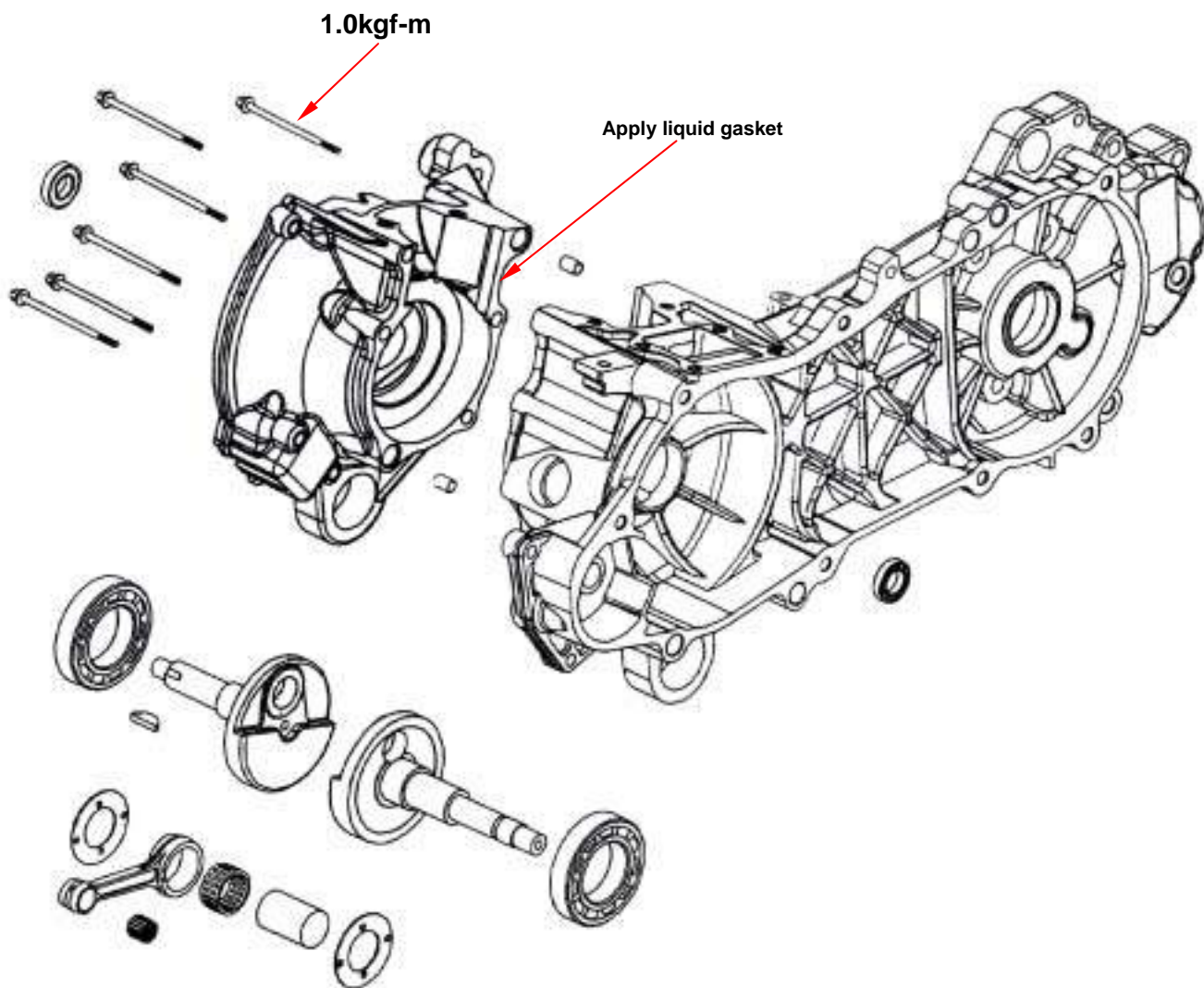

9. CRANKCASE/CRANKSHAFT

Maintenance Information

- This chapter concerns disassembly of the crankcase for repair purpose.
- Before disassembling crankcase, except removing engine firstly, following components must be removed too.
 - Carburetor (chapter 10)
 - Oil pump (chapter 3)
 - Reed valve (chapter 10)
 - Driving belt (chapter 7)
 - Alternator (chapter 6)
 - Cylinder head/cylinder/piston (chapter 5)
- Except above components are needed be removed, when disassembling L crankcase, following components must be removed too.
 - Final driving mechanism (chapter 8)
- When assembling both crankcase and crankshaft, it has press the inner ring edge of the crankshaft bearing to push the crankshaft into the crankcase hole by using the specified service tools. The old bearing onto the crankshaft has to be removed. Then install a new bearing onto the crankshaft on the crankcase side. Oil seal has to be replaced with new one after assembled the crankcase.

Item	Standard	Limit (mm)
Lateral clearance of the big end of the connecting rod		0.60
Radial clearance of the big end of the connecting rod		0.04
Crankshaft run-out point A		0.10
Crankshaft run-out point B		0.10

Special Tools

- Crankcase disassemble tool (SYM-1120100-G5)
- Outer bearing puller (SYM-6204010)
- R. Crank shaft puller (SYM-1130000-R)
- R. Crank shaft install bush (SYM-1130020)
- L. Crank shaft puller (SYM-1130000-L)
- L. Crank shaft install bush (SYM-1130010)
- 20*32*6 Oil seal driver (SYM-9120200)
- Bearing driver 6204 (SYM-9110400)

Troubleshooting

Engine noise

1. Worn bearing of connecting rod bog end
2. Bend connecting rod
3. Worn crankshaft bearing

Crankcase Disassembly

Remove the crankcase bolts.

Install the crankcase puller onto the right crankcase with two (2) bolts, 6mm, as the diagram shown.

Disassemble the right crankcase.

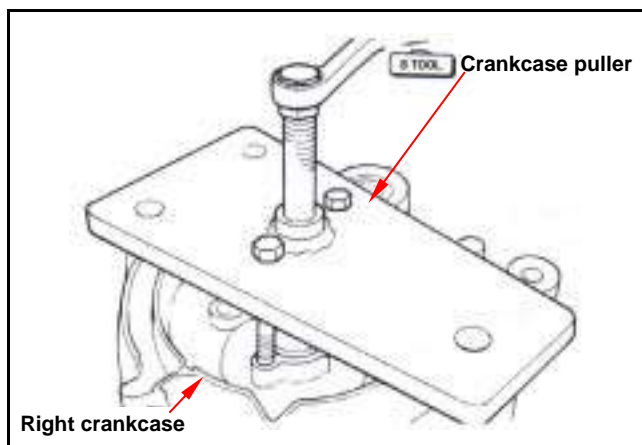
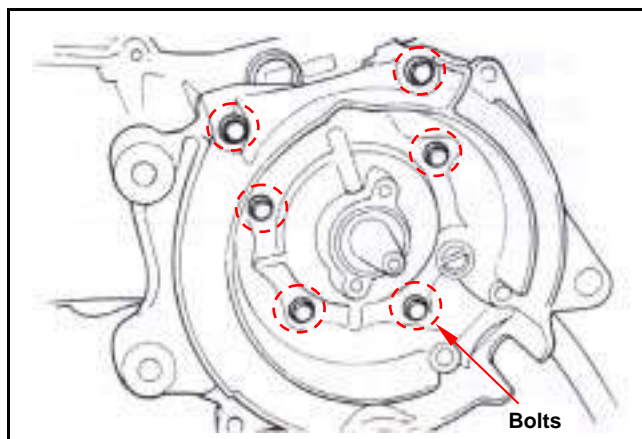

Crankshaft Removal

As the diagram show with 3 special bolts to install the crankcase puller onto the left crankcase.

Remove the crankcase.

⚠ Caution

Do not use iron hammer to knock out the crankshaft.

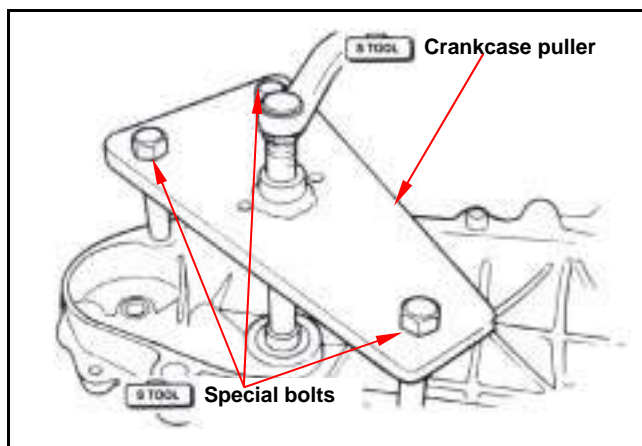

Remove crankshaft bearing with outer bearing puller.

Remove the right and left side oil seals.

⚠ Caution

Replace the oil seal with new one as removing the crankshaft.

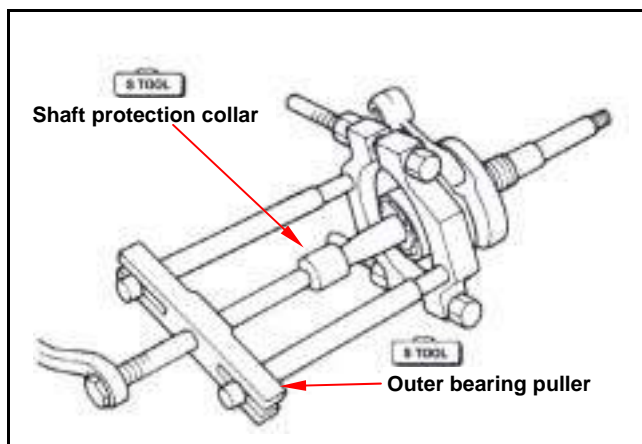

9. CRANKCASE/CRANKSHAFT

Crankshaft Inspection

Measure the clearance of connecting rod big end.

Service limit: 0.60 mm

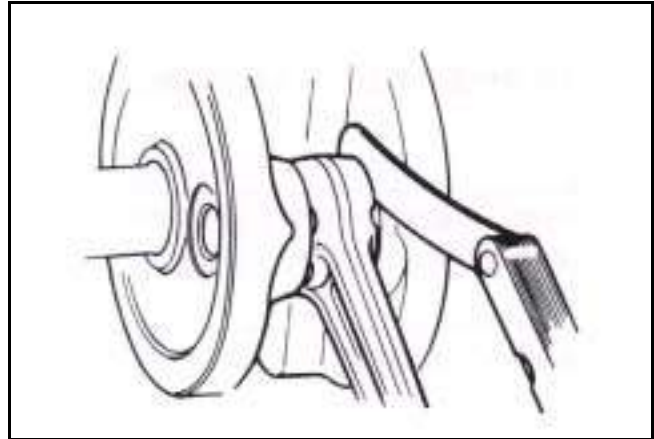

Measure the radial clearance of connecting rod big end at X-Y directions as diagram show.

Service limit: 0.04 mm

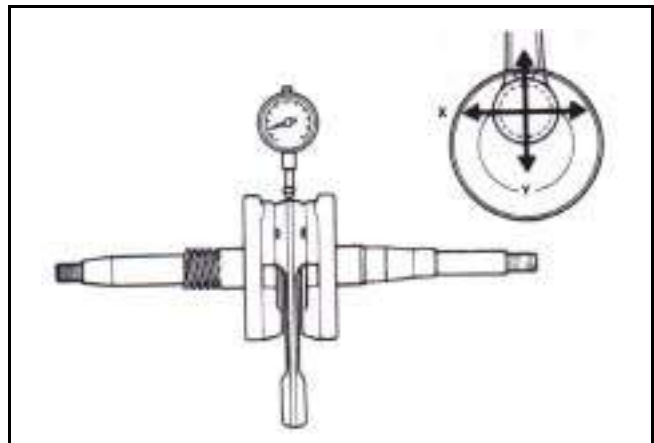

Place the crankshaft on a V-block, measure run-out points A and B of the crankshaft with dial gauge.

Service limit: A: 0.10 mm

B: 0.10 mm

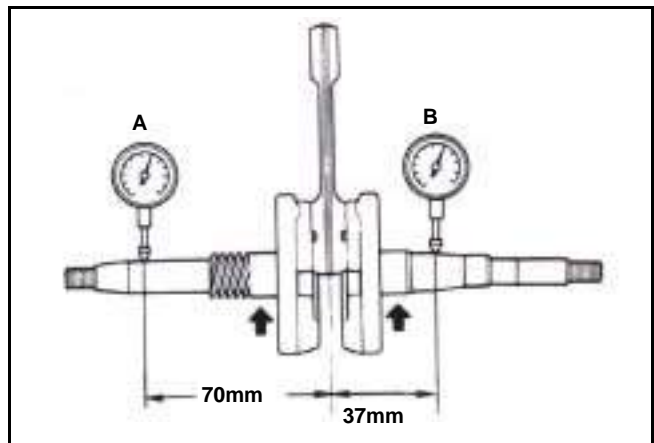

Check the crankshaft bearing by means of turning it with hand. If any noise and bigger clearance are detected, replace the bearing with new one.

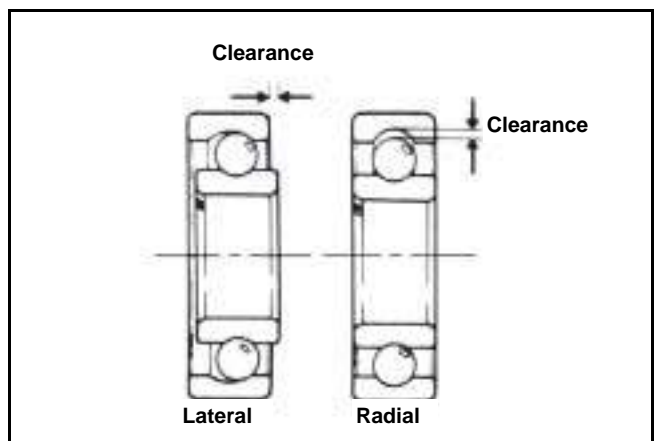

Crankcase Installation

Clean the crankshaft with solvent and blow it with compressed air. Then, check for damage or other foreign materials attached.

Install new bearing into right crankcase.

⚠ Caution

- All rotation and sliding surfaces have to be applied with clean engine oil.
- Remove all gaskets onto the crankcase interfaces and flat it with special tool.

Install new bearing into left crankcase.

Install crankshaft onto the left crankcase.

Install left crankshaft puller and install bush onto crankshaft.

Screw the left crankshaft puller onto crankshaft.

Turn the puller in C.W. direction and then completely screw the puller to bottom.

Lubricate crankshaft bearing and bearing seat with 2-stroke engine oil.

Apply liquid gasket and dowel pin onto the interface of left crankcase.

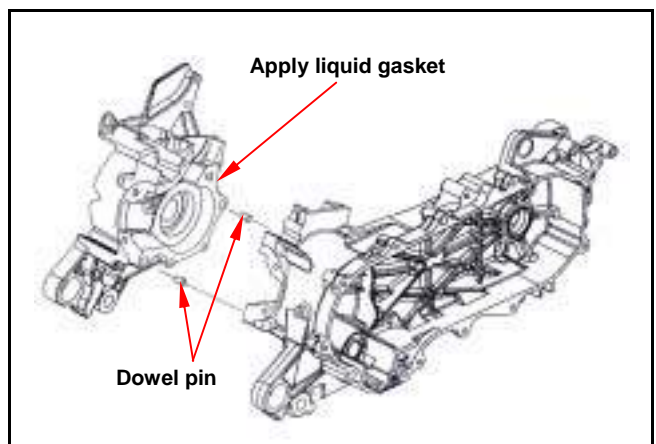
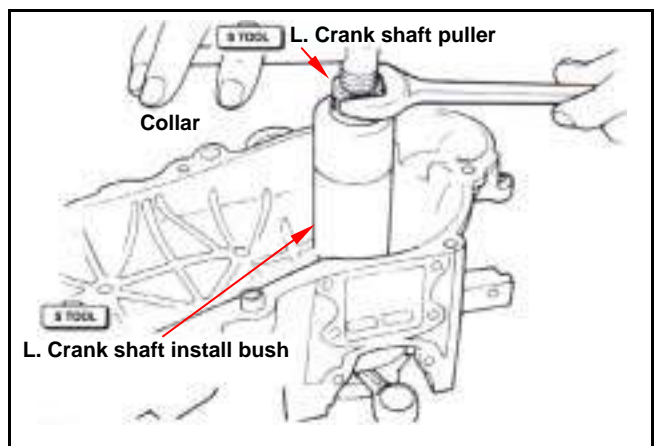
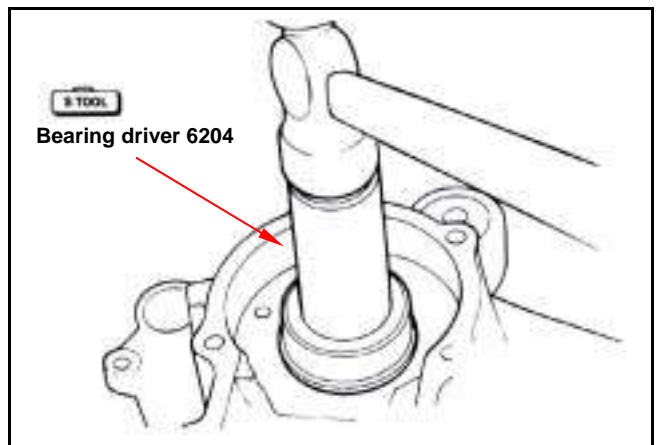
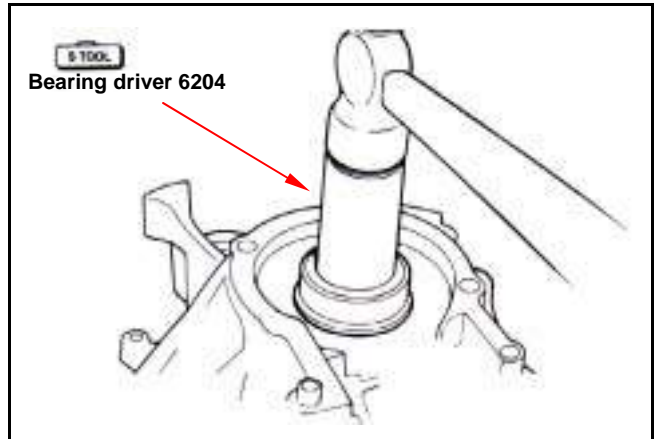

9. CRANKCASE/CRANKSHAFT

Assemble the right crankcase with assembly tools.
 Install right crankcase onto the crankshaft.
 Install right crankshaft puller and install bush onto crankshaft.
 Screw the right crankshaft puller onto crankshaft.
 Turn the puller in C.W. direction and then completely screw the puller to bottom.
 Lubricate crankshaft bearing and bearing seat with 2-stroke engine oil.

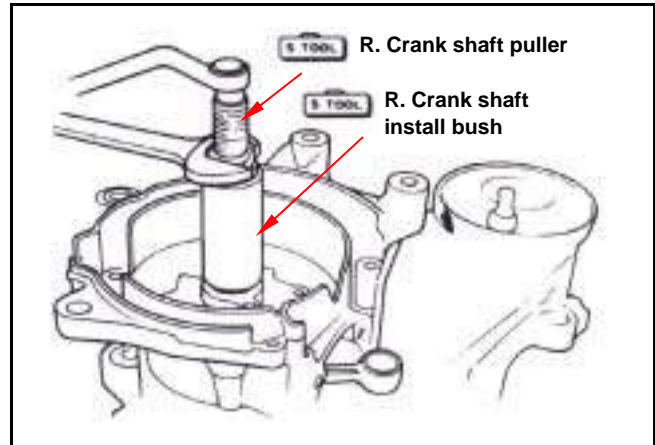

Install the bolts and tighten them.

Torque value: 1.0kgf-m

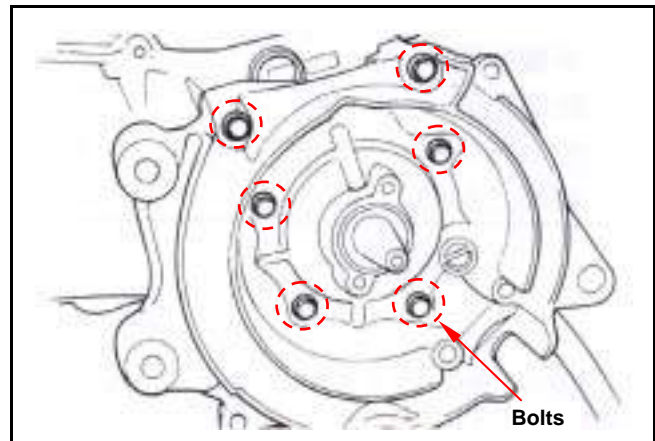

With right crank shaft install bush, install new oil seal into the right crankcase. Its installation depth is 4mm as the diagram shown.

With the specified tool to install a new oil seal onto the left crankcase to the depth of 1 mm as the diagram shown.

Caution

Make sure that the crankshaft can be rotated freely after tightening the bolts.

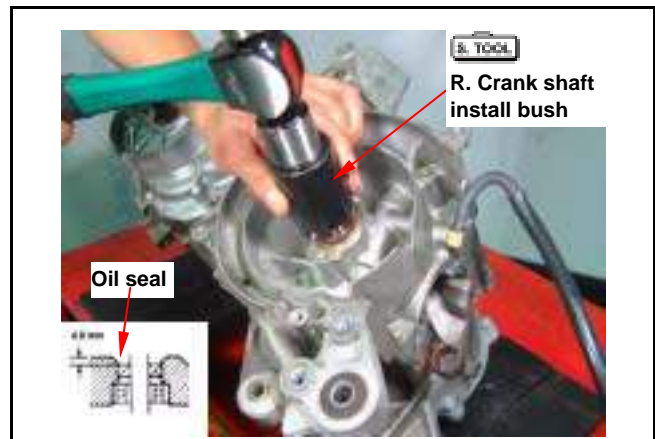

Install the following components:

- ~ Final driving mechanism (chapter 8)
- ~ Alternator (chapter 6)
- ~ Piston/cylinder/cylinder head (chapter 7)
- ~ Oil pump (chapter 3)
- ~ Reed valve and carburetor (chapter 10)
- ~ Engine (chapter 4)

Maintenance Information.....10-2	Float Level Inspection10-7
Troubleshooting.....10-2	Carburetor Installation10-7
Throttle Valve10-3	Reed Valve.....10-7
Carburetor Remove.....10-4	Fuel Pump10-8
Auto By-Starter.....10-4	Air Cleaner.....10-9
Float/Float Valve/Jet10-6	

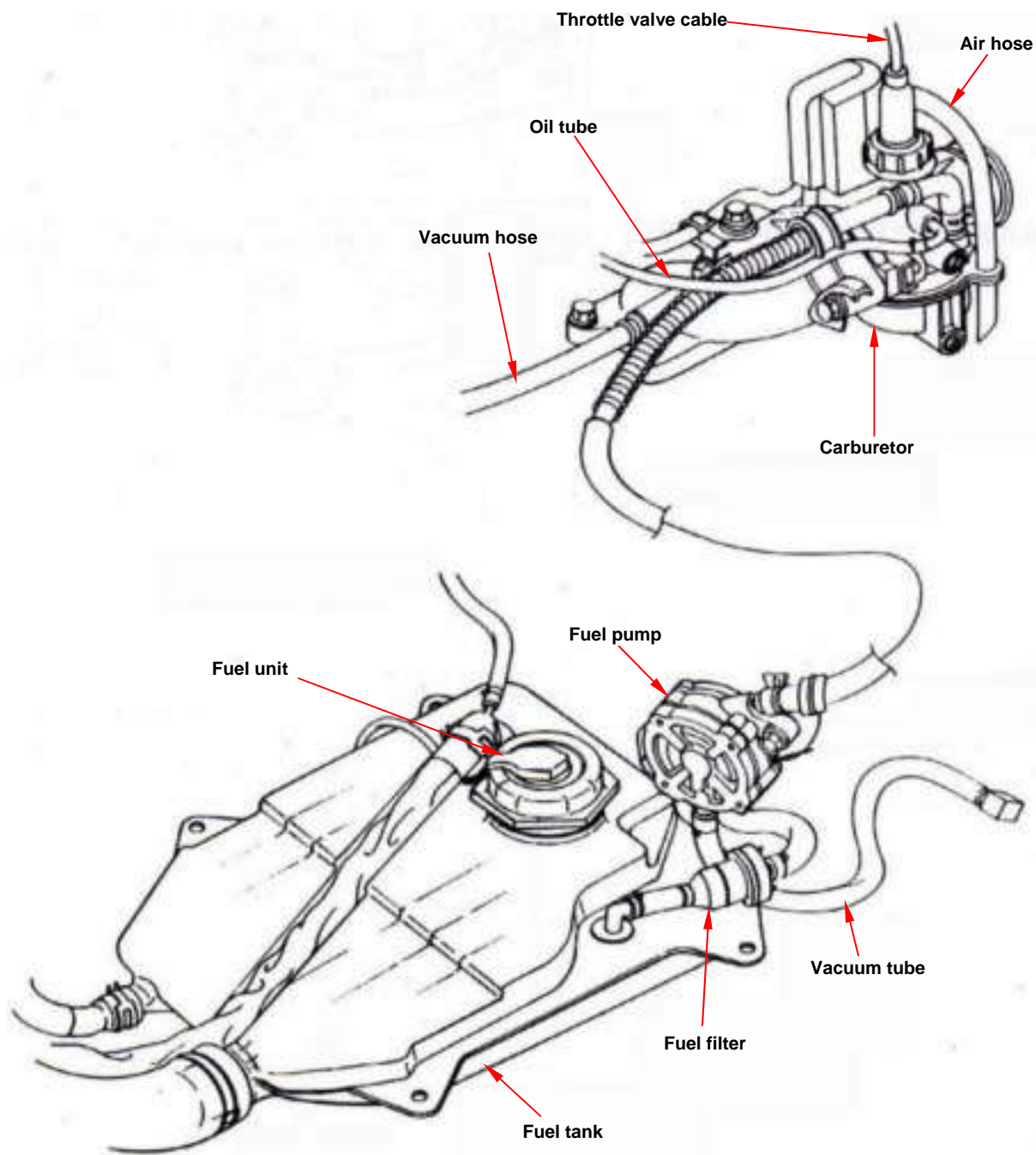

10. FUEL SYSTEM

Maintenance Information

Precautions in Operations

Warning

Gasoline is a highly flammable material and may explosive under circumstance. Thus, always work in a well-ventilated place and strictly prohibit flame when working with gasoline.

- Care must be taken when dealing with gasoline, and always work in a well-ventilated place and strictly prohibit flame.
- When disassembling fuel system parts, pay attention to O-ring position, replace with new one as re-assembly
- It has to conduct air bleeding operation as removed the oil tube.
- Idle speed adjustment.

Specification

Item	DD 50
Venturi diameter	14 mm
Fuel level	8.6±1.0mm
Air screw opener	1 3/8
Idle speed	2000±100 rpm
Throttle handle free play	2~6 mm
I.D. number	PB2BE
Main jet	#82
Fuel pump output	20 c.c. minimum.

Troubleshooting

Engine can not be started

1. No fuel in fuel tank
2. Fuel can not reach to carburetor
3. Too much fuel in cylinder
4. Clogged air cleaner

Stall after started

1. Incorrect idle speed adjustment
2. No spark on the spark plug
3. Low compression pressure
4. Rich mixture
5. Lean mixture
6. Clogged air cleaner
7. Inlet pipe leaking
8. Polluted fuel

Lean Mixture

1. Clogged carburetor jet
2. Clogged hose from carburetor to canister
3. Bend, squeezed or clogged fuel lines
4. Clogged fuel filter
5. Malfunction of float valve
6. Low fuel level in float chamber
7. Clogged vent pipe
8. Malfunction of fuel pump

Rich Mixture

1. Malfunction of float valve
2. Low fuel level in float chamber
3. Clogged carburetor air injector

Throttle Valve

Removal

- Remove the body cover.
- Remove the carburetor upper part, throttle valve spring and sealed cap.
- Remove the throttle valve cable from the throttle valve.
- Remove needle clamp and fuel needle.

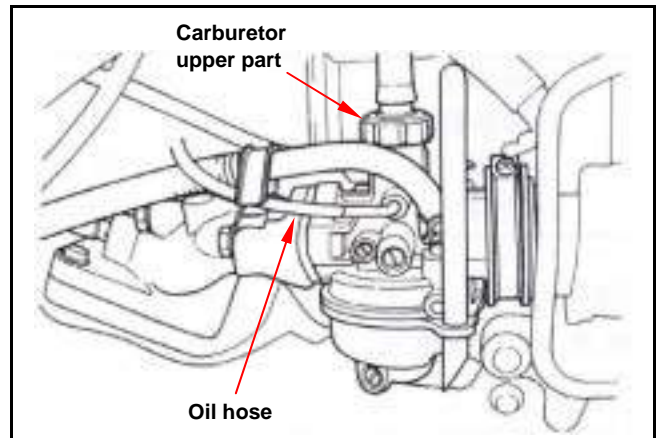

Inspection

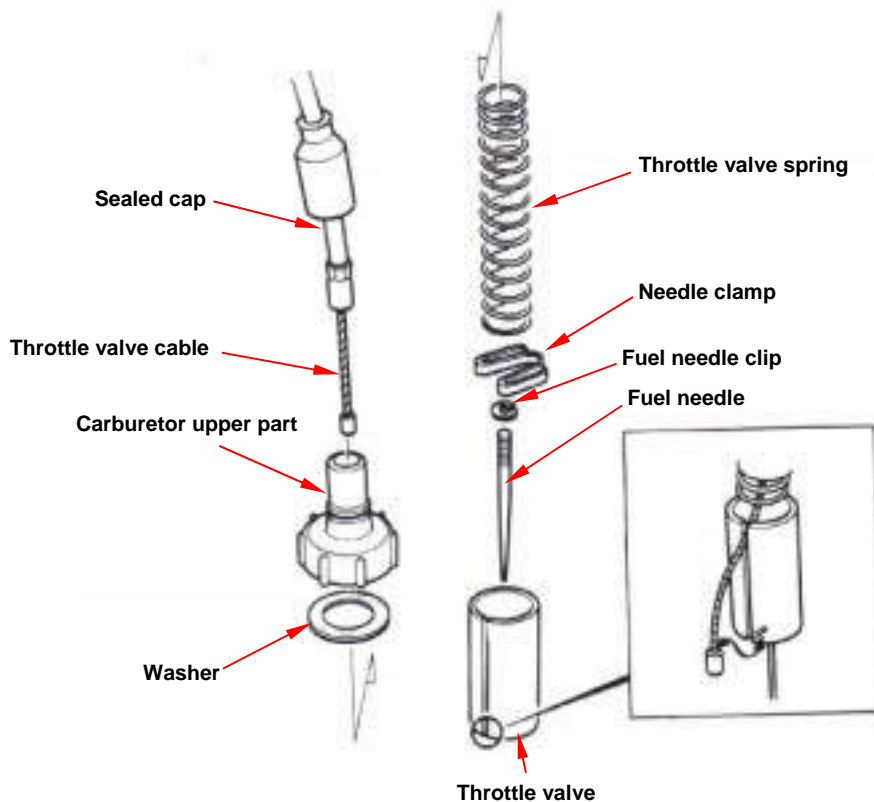

Installation

- Place the fuel needle onto the throttle valve and clip it with needle clamp.
- Install the sealed cap, carburetor upper part, and throttle valve spring.
- Connect the throttle valve cable to the throttle valve.
- Install the throttle valve into the carburetor body.

⚠ Caution

Align the groove inside the throttle valve with the throttle stopper screw of the carburetor body.

- Tighten the carburetor upper part.
- Install carburetor protector.
- Adjust the free play of throttle valve cable.

10. FUEL SYSTEM

Carburetor Remove

Remove the body cover.



Disconnect the auto by-starter connector.

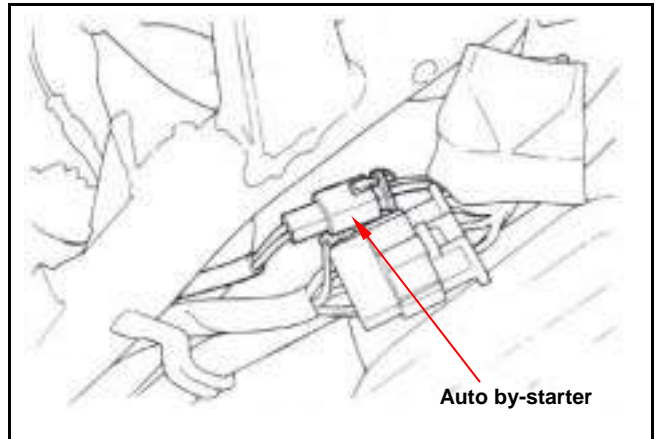

Loosen draining screw and then drain out fuel inside the carburetor.
 Loosen carburetor upper part and remove carburetor upper part.
 Remove fuel and oil hoses from carburetor.
 Remove carburetor mounting bolt and carburetor.

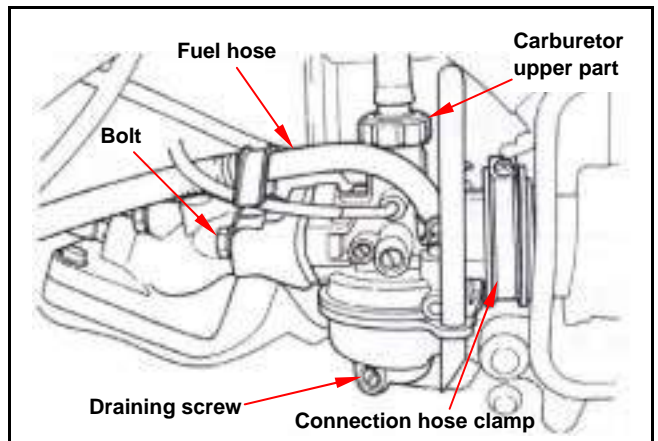

Auto By-Starter

Inspection

Connect resistor meter to the terminals of auto by-starter, and then measure its resistance.
 If the resistance value exceeds specification too much, it means that the PTC in the auto by-starter is malfunction. Then, replace the auto by-starter.

Resistance value: Max. 10 (at cold engine)

Caution

If the resistance value exceeds the standard a little bit, the auto by-starter may still in normal. However, it is necessary to check other relative components for damage.

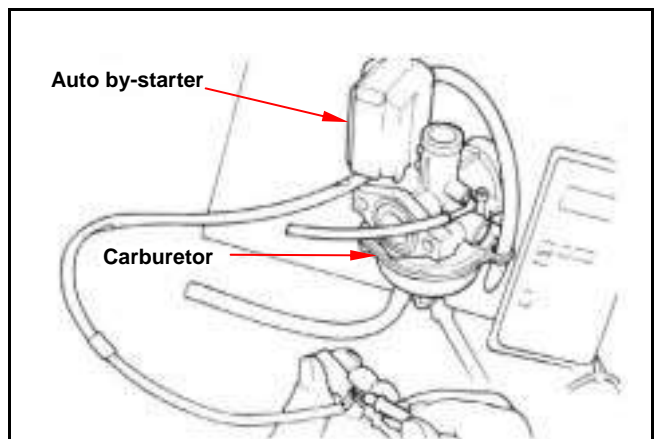

Remove carburetor, and allow it to cool off for 30 minutes.

Connect fuel rich circuit with a hose and pump compressed air to the hose.

Air should flow into fuel rich circuit.

Replace the auto by-starter if the circuit clogged.

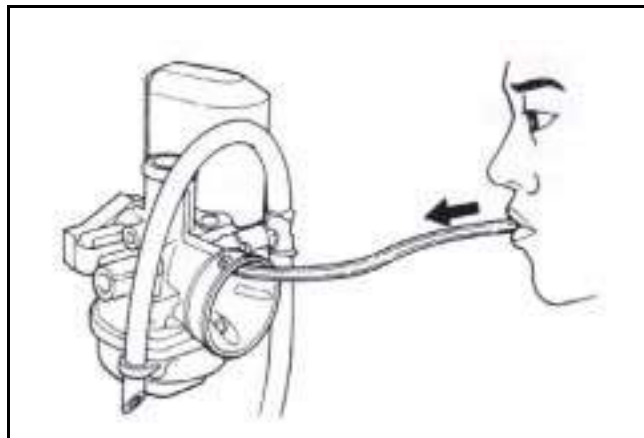

Connect battery to starter's connectors and wait for several minutes.

Pump compressed air into the fuel rich circuit.

Air should not flow into the circuit.

If air flow through the circuit, then, replace the starter.

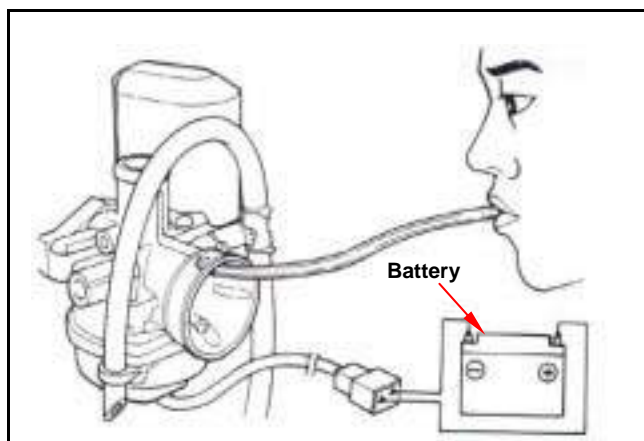

Check resistor to make sure that the auto by-starter is in normal. Engine is running.

If the resistor is in open-circuit, then current will not flow into the PTC. Thus, the auto by-starter is not operated.

However, if the resistor is in short-circuit, current higher than specification will flow into the PTC.

Then, it will cause the fuel rich circuit close rapidly, and difficult to start the scooter.

Resistance value: 10.2

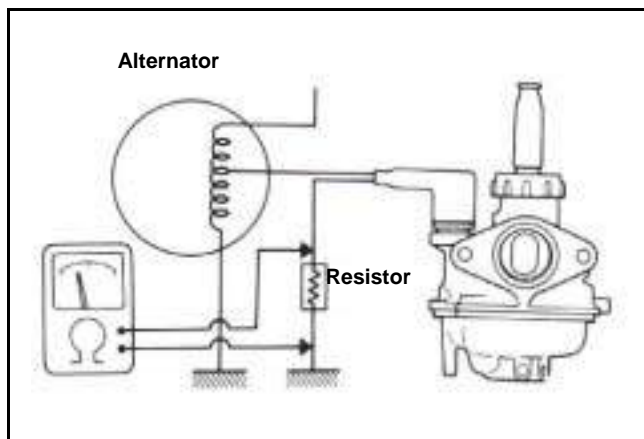

Automatic By-Starter Removal/Installation

Remove the cover of the auto by-starter.

Remove screw and mounting plate.

Remove the auto by-starter from carburetor.

Install in the reverse order of removal procedures.

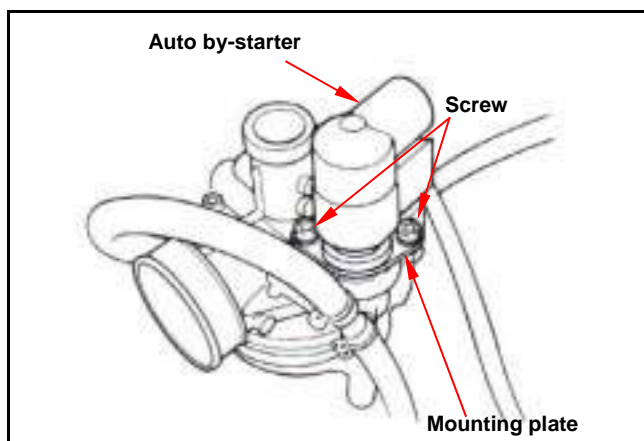

10. FUEL SYSTEM

Float/Float Valve/Jet

Removal

Remove the float from carburetor body.
 Remove the float pin and then remove float and float valve.
 Check the valve seat for worn out or damage.
 Check float for bend and if fuel inside the float.
 Before removing both the throttle valve stopper and air screws, record their original turns for close to their original set up position as installation.

⚠ Caution

Do not tighten the screw forcedly to avoid to damaging the valve seat.

Remove main jet, needle jet seat and idle jet and clean them and each component with compressed air.

Installation

Install the idle jet, the needle jet seat and main jet. Then install the throttle valve stopper and air screws to their original position according to the marks as removal. Adjust the screws if replace with new ones.

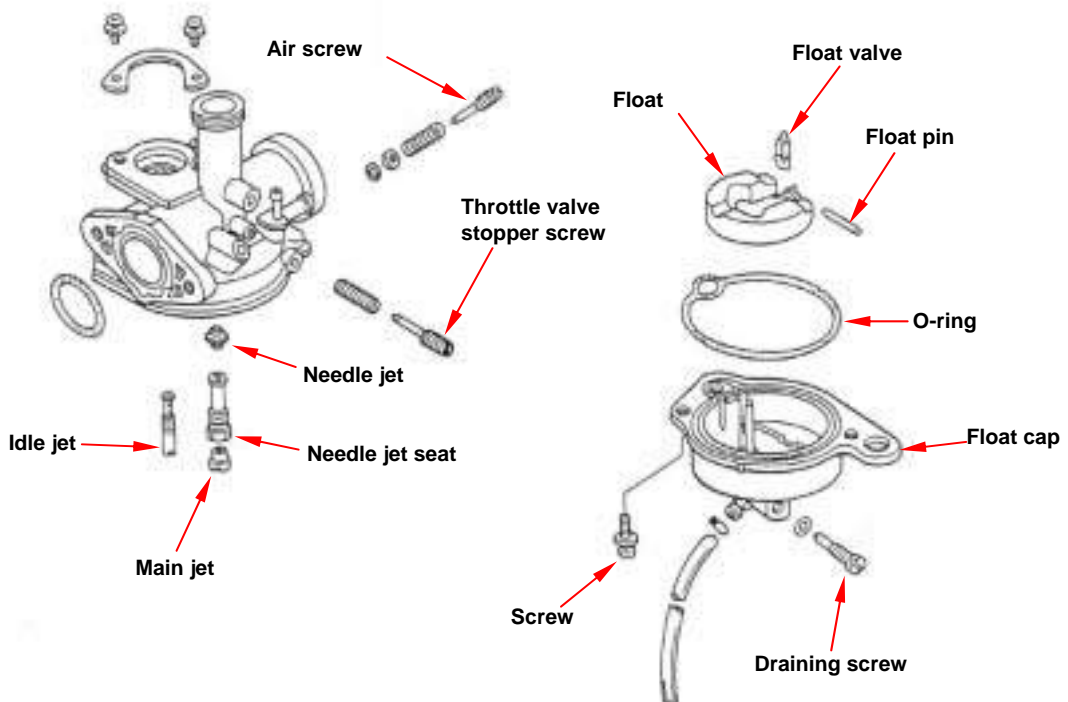
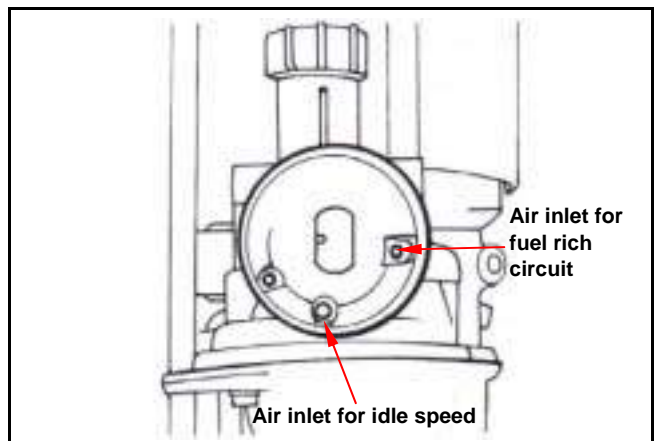
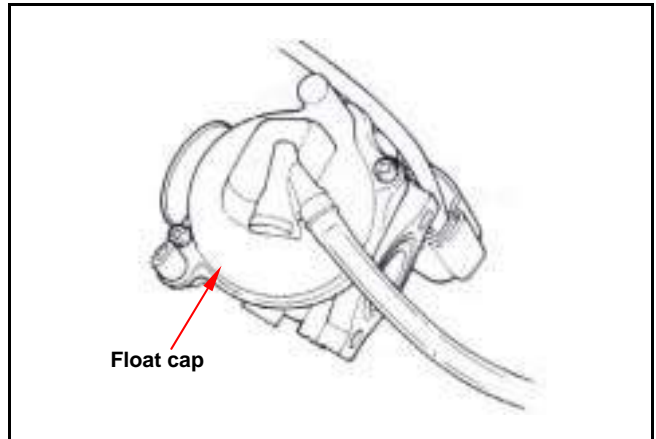

Float Level Inspection

Measure float fuel level to have the upper end of float just contact with the float.

Float fuel level: 8.8 mm

Carefully bend the float arm for adjustment.

Check the float operation and the install it.

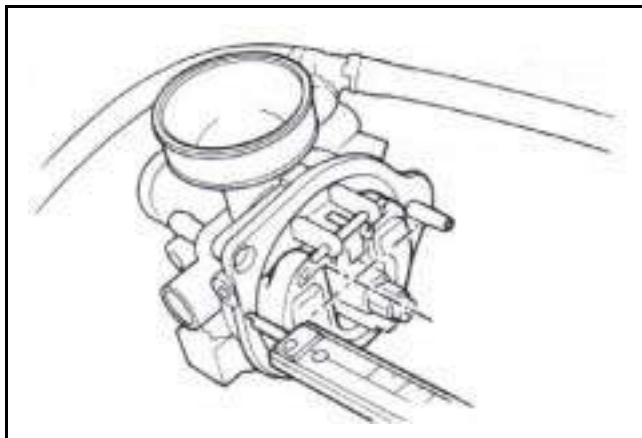

Carburetor Installation

⚠ Caution

Do not let foreign materials into the carburetor.

Install the carburetor and insulator onto intake pipe with bolts.

Install fuel and vent pipes onto carburetor.

Install the carburetor upper part.

Tighten the connection hose.

Tighten the draining screw.

Connect the automatic by-starter connector.

Install air cleaner cap.

Conduct following operations

- Adjustment of throttle valve cable.
- Adjustment of oil pump.
- Adjustment of idle speed.

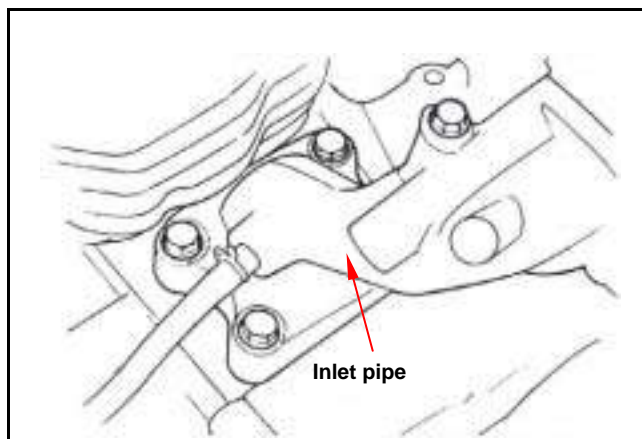
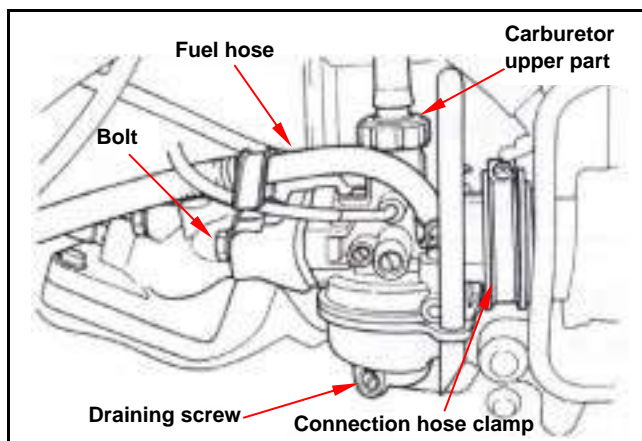

Reed Valve

Removal

Remove the body cover.

Remove the carburetor.

Remove carburetor insulator.

Remove inlet pipe.

Remove the reed valve.

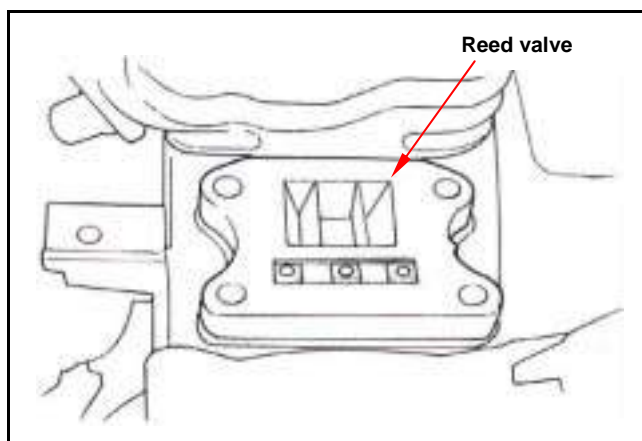

10. FUEL SYSTEM

Inspection

Check the reed valve for damage and its reed strength.

Check the reed valve seat for crack, damage and the clearance between the seat and the valve.

Replace reed valve if necessary.

⚠ Caution

Do not bend the reed valve stopper. Otherwise, it will cause its strength insufficient and rough engine running. If the reed valve or its seat is damaged, replace with a set.

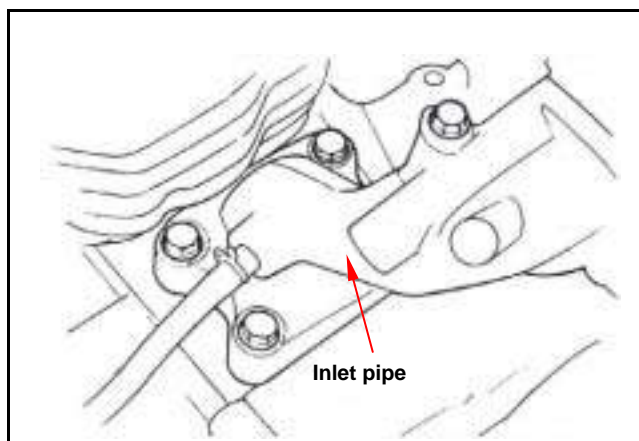
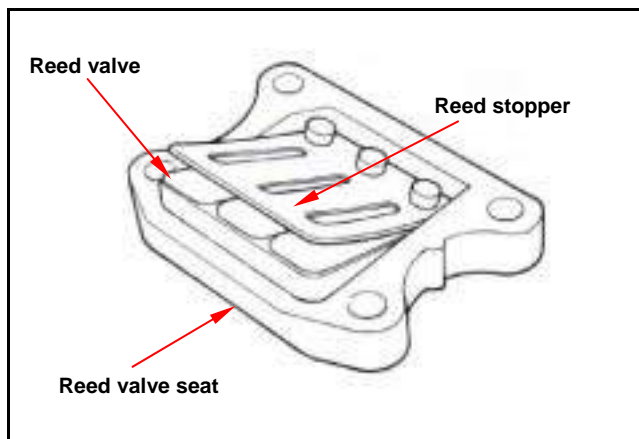

Installation

Install in the reverse order of removal procedures.

Check for leaking after installed.

Fuel Pump

Inspection

Remove the body cover.

Warm up the engine and adjust idle speed.

Remove fuel hose from carburetor and then wait for 5 minutes.

Measure the output of fuel pump. Its output time is 10 seconds.

Output quantity: Min. 20 c.c.

If the output quantity is lower than 20 c.c., check fuel hose, vacuum hose and fuel filter.

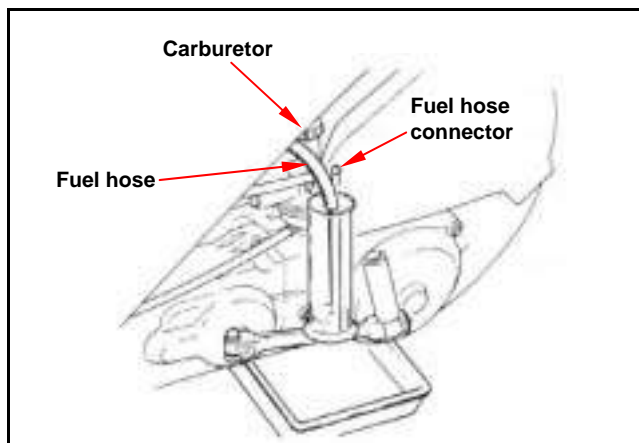

Removal/Installation

Remove floor plate.

Remove fuel inlet, outlet and vacuum hoses.

Remove 2 bolts and fuel pump.

Install the fuel pump in the reverse order of removal procedures.

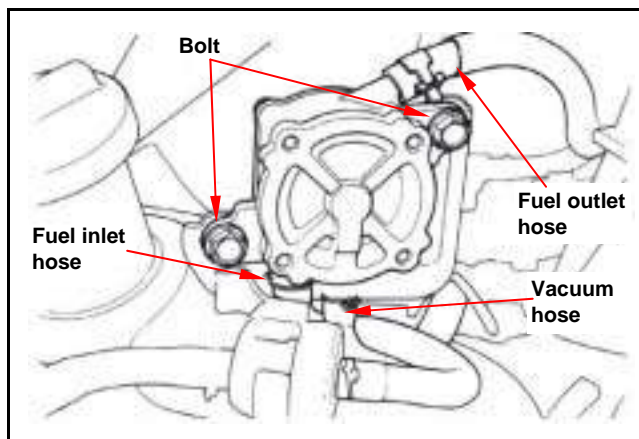

Air Cleaner

Removal/Installation

Remove the EEC hose from the air cleaner outer case.

Loosen connection hose clamp.

Remove 2 bolts and then remove the air cleaner outer case.

Install in the reverse order of removal procedures.

Install the air cleaner outer case.

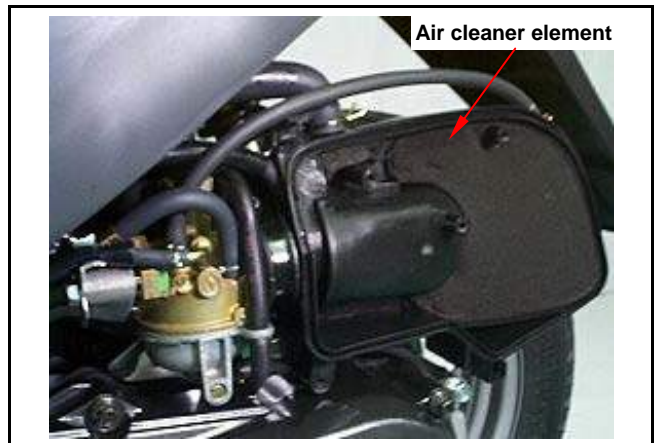
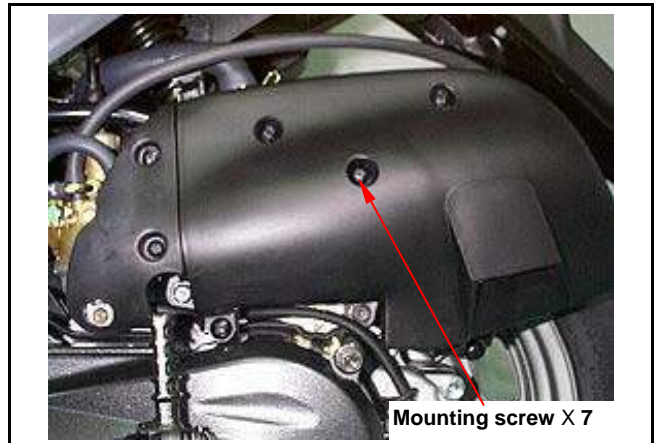

10. FUEL SYSTEM



Notes:



Front Disc Brake System	11-1	Disc Brake -Air Bleed	11-7
Front Drum Brake System.....	11-2	Disc Brake - Caliper.....	11-7
Rear Drum Brake System.....	11-3	Brake Disc	11-8
Maintenance Information	11-4	Disc Brake - Master Cylinder	11-8
Troubleshooting	11-5	Drum Brake	11-11
Hydraulic Disc Brake.....	11-6		

Front Disc Brake System

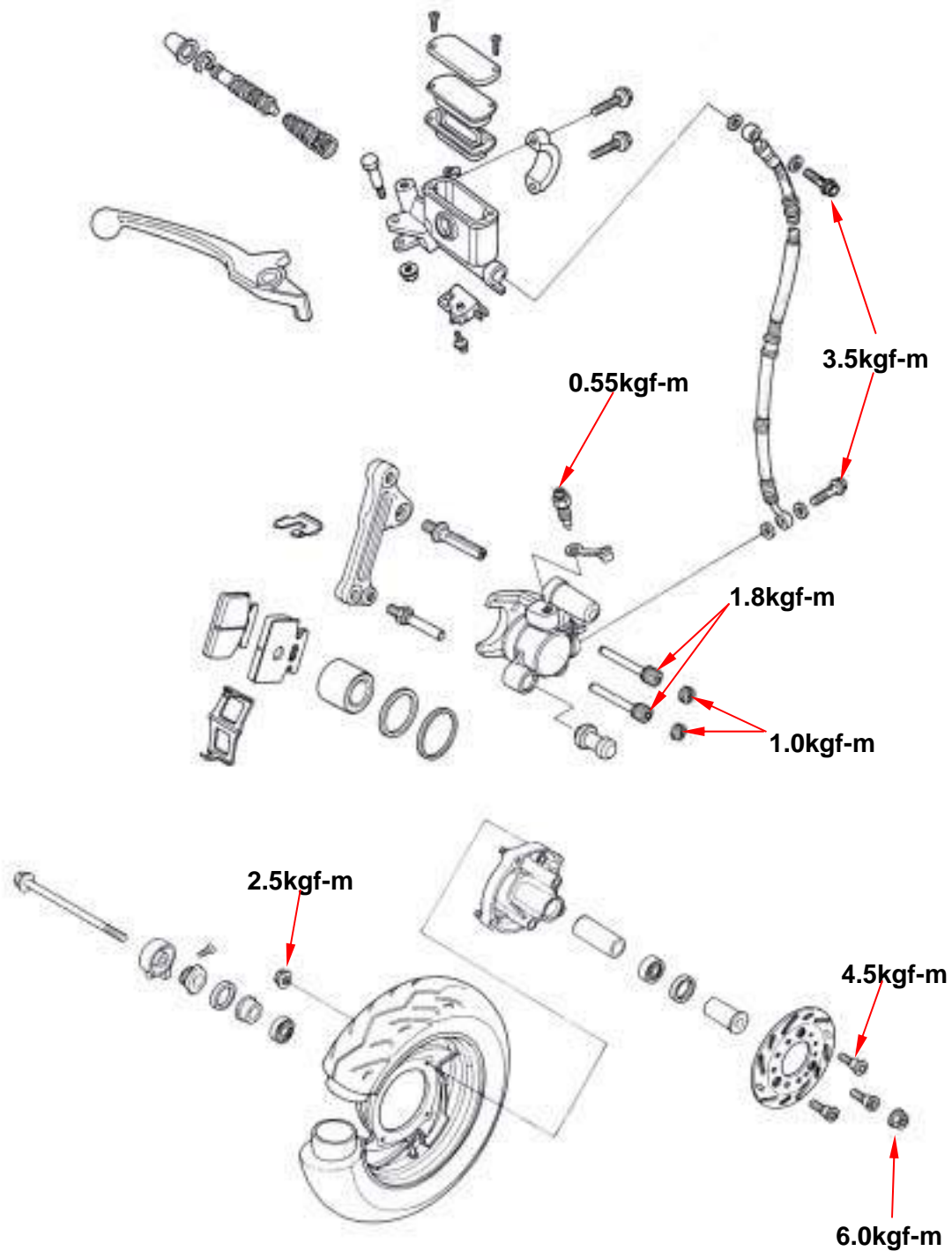

11. BRAKE SYSTEM

Front Drum Brake System

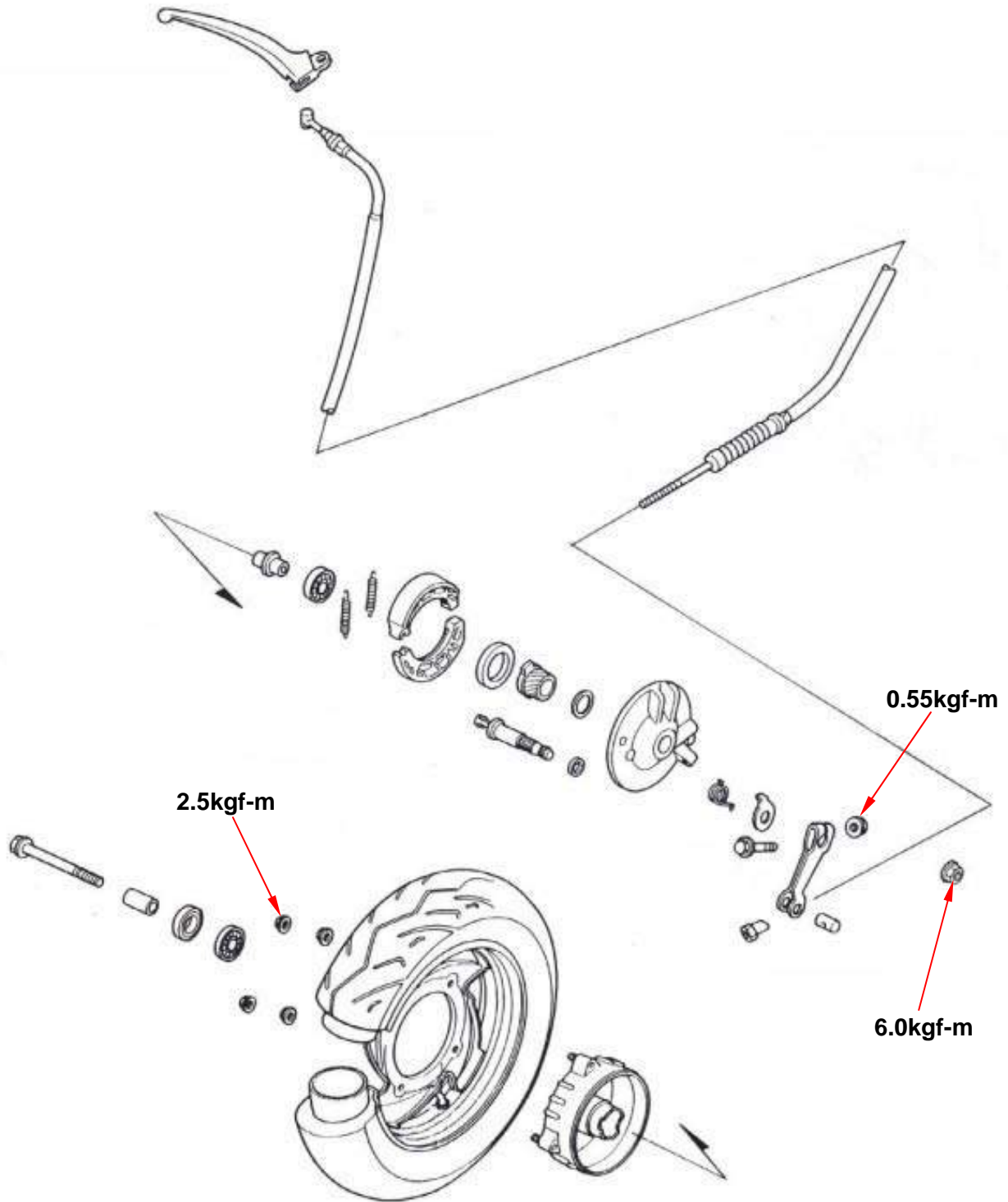

Rear Drum Brake System

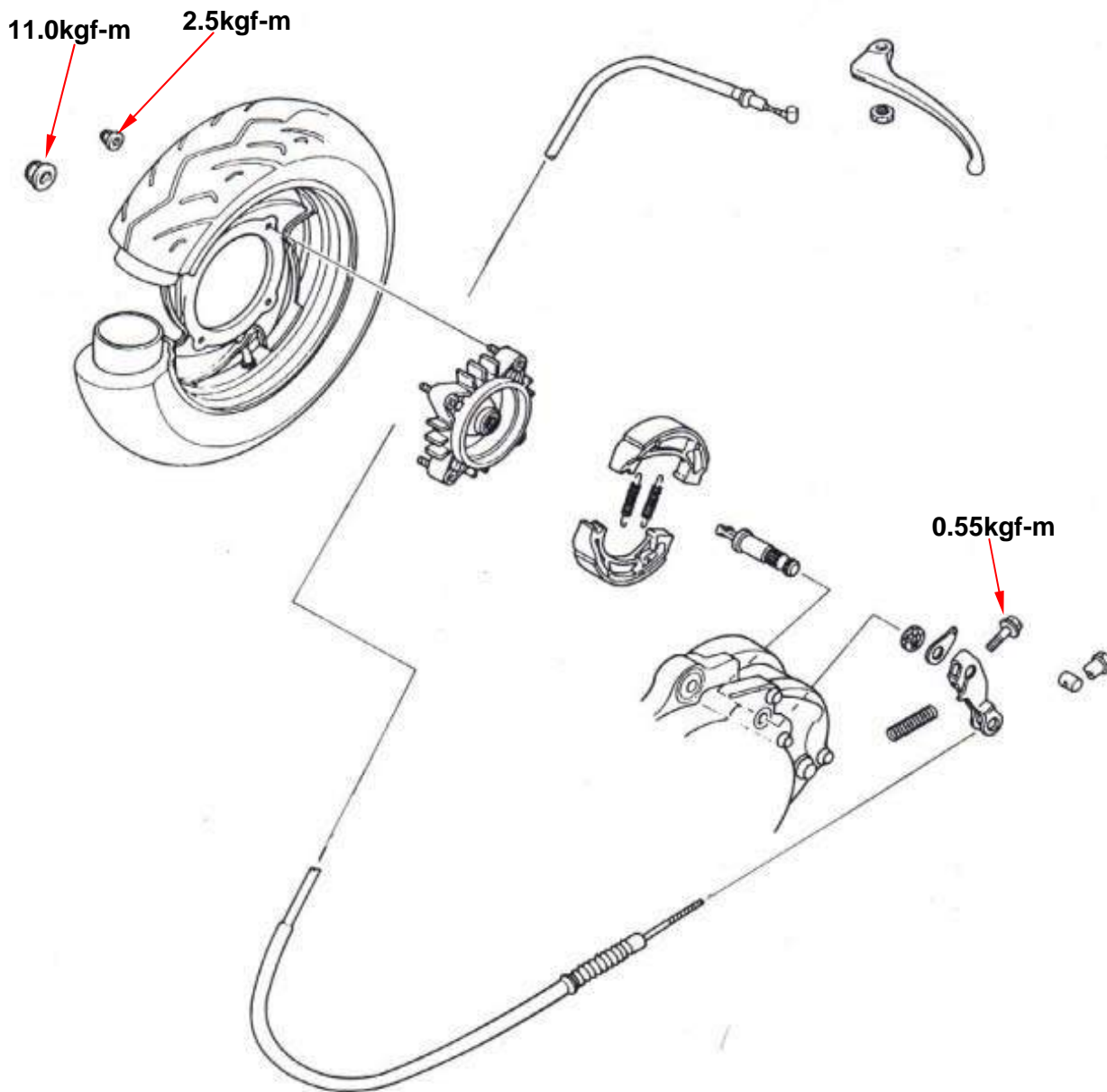

11. BRAKE SYSTEM

Maintenance Information

Precautions in Operation

Caution

Inhaling brake lining ashes may cause disorders of respiration system, therefore, never use air hose or dry brush to clean brake parts. Use vacuum cleaner or other authorized tool instead.

- The brake caliper can be removed without removing the hydraulic system.
- After the hydraulic system is removed, or the brake system is felt to be too soft, bleed the hydraulic system.
- While refilling brake fluid, care should be taken not to let the foreign material entering into the brake system.
- Do not spill brake fluid on the painted surfaces, plastic or rubber parts to avoid damage.
- Check the operation of the brake system before you go.

Specifications

Item	Standard (mm)	Limit (mm)
The thickness of front brake disc	3.5	2.0
Front brake disc run-out	< 0.10	0.3
Master cylinder inner diameter	12.700 – 12.743	12.55
Master cylinder piston outer diameter	12.657 – 12.684	12.654
ID of front brake drum	110.0	110.5
ID of rear brake drum	95.0	95.5
Thickness of front brake lining	4.0	2.0
Thickness of rear brake lining	4.0	2.0

Torque values

Brake hose bolt	3.5kgf-m
Bolt for brake caliper	3.3kgf-m
Bolts for the lining guide pin	1.8kgf-m
Bolts for the lining guide pin cap	1.0kgf-m
Air-bleed valve	0.55kgf-m
Bolts for the brake disc	4.5kgf-m
Nuts for the wheel rim	2.5kgf-m
Nuts for the front wheel	6.0kgf-m
Nuts for the rear wheel	11.0kgf-m
Bolt for rear brake arm	0.55kgf-m

Troubleshooting

Disc Brake

Soft brake lever

1. Air inside the hydraulic system
2. Hydraulic system leaking
3. Worn master piston
4. Worn brake pad
5. Poor brake caliper
6. Worn brake lining/disc
7. Low brake fluid
8. Blocked brake pipe
9. Warp/bent brake disc
10. Bent brake lever

Hard operation of brake

lever

1. Blocked brake system
2. Poor brake caliper
3. Blocked brake pipe
4. Seized/worn master cylinder piston
5. Bent brake lever

Uneven brake

1. Dirty brake lining/disc
2. Poor wheel alignment
3. Clogged brake hose
4. Deformed or warped brake disc
5. Restricted brake hose and fittings

Tight brake

1. Dirty brake lining/disc
2. Poor wheel alignment
3. Deformed or warped brake disc

Brake noise

1. Dirty lining
2. Deformed brake disc
3. Poor brake caliper installation
4. Imbalance brake disc or wheel

Drum Brake

Poor brake performance

1. Improper brake adjustment
2. Worn brake lining
3. Worn brake drum
4. Worn brake cam
5. Improper brake lining installation
6. Seized brake cable
7. Dirty brake lining
8. Dirty brake drum
9. Brake pad worn in brake cam area.
10. Poor contact between brake arm and camshaft indent

Tight operation or low

return speed of brake

lever

1. Worn/broken/crack return spring
2. Worn drum
3. Dirty brake lining
4. Brake seized caused from dirty brake drum
5. Seized brake cable
6. Worn brake cam
7. Improper brake lining installation

Brake noise

1. Worn brake lining
2. Worn drum
3. Dirty brake lining
4. Dirty brake drum

11. BRAKE SYSTEM

Hydraulic Disc Brake

Close the drain valve of the hydraulic disc brake.
Replace the brake fluid.

Before the brake fluid reservoir is removed, turn the handle so that the brake fluid reservoir becomes horizontal, then remove the brake fluid reservoir.

Cover the painted surfaces, plastic or rubber components with a rag when servicing brake system.

Caution

Spilled brake fluid on painted surfaces, plastic or rubber components may result in their damages.

Remove the master cylinder cap and diaphragm.
Use brake fluid to clean the dirty brake disc.

Caution

The dirty brake lining or disc will reduce the brake performance.

Refill up same grade brake fluid into the reservoir.

Caution

To mixed non-compatible brake fluid will reduce brake performance. Foreign materials will block the system causing brake performance to be reduced or totally lost.

Connect drain hose to drain valve.
Open the drain valve on the caliper and operate the brake lever until the old brake fluid is entirely drained out. Close the drain valve and add specified brake fluid into the brake master cylinder.

Recommended brake fluid: WELLRUN DOT 3 brake fluid

Caution

To reuse the spent brake fluid will effect brake performance.

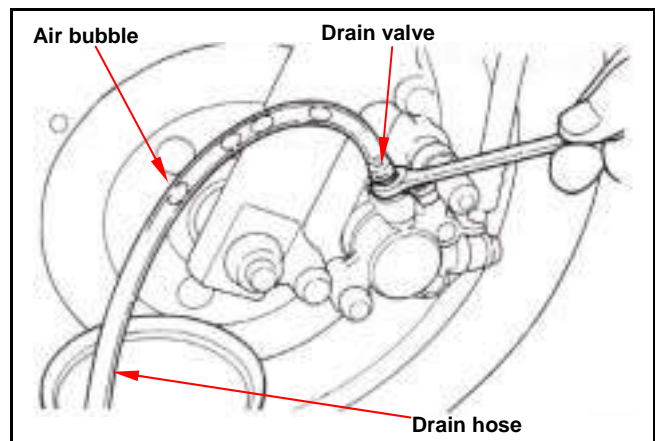
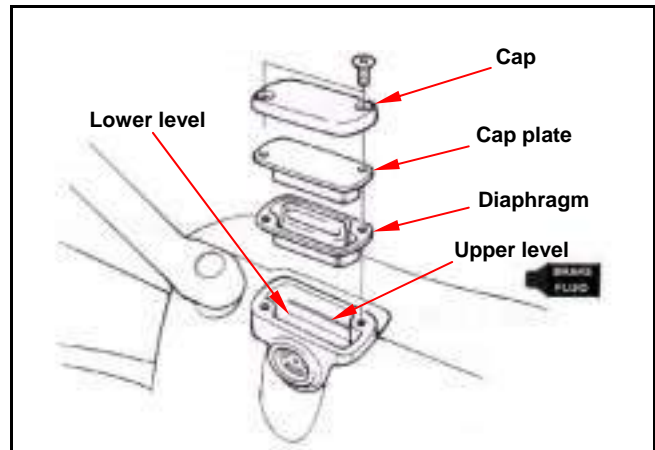

Connect one end of transparent hose to the drain valve, and put the other end into a container.
Open the drain valve around 1/4 turns, and at the same time hold the brake lever until there is no air bubble in the drain hose and also feeling resistance on the brake lever.

Close the drain valve when finishing the brake system refilling fluid procedure, and operate the brake lever to check whether air bubble is in brake system or not. If brake is still soft, please bleed the system as described below.

Disc Brake -Air Bleed

1. Tightly hold the brake lever and open the drain valve around 1/4 turns, and then close the valve.

⚠ Caution

- Do not release the brake lever before the drain valve is closed.
- Always check the brake fluid level when carrying out the air bleeding procedure to avoid air enter into the system.

2. Slowly release the brake lever, and wait for a few seconds until it reaches its top position.
3. Repeat the steps 1 and 2 until there is no air bubble at the end of the hose.
4. Tightly close the drain valve.
5. Make sure the brake fluid is in the UPPER level of the master cylinder, and refill the fluid if necessary.
6. Cover the cap.

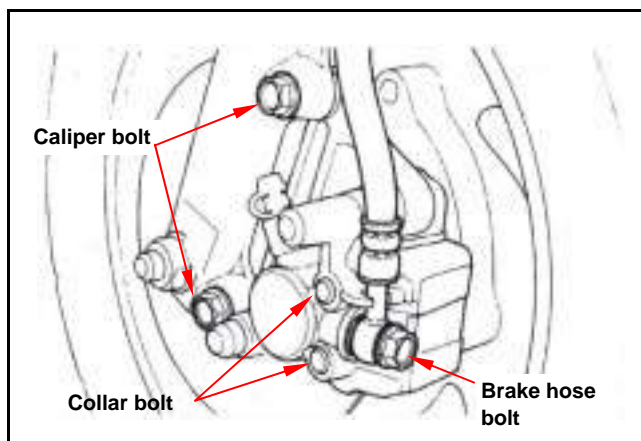
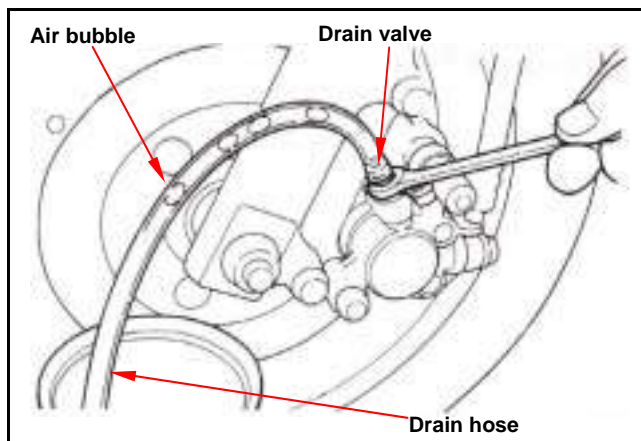

Disc Brake - Caliper

Removal

Place a container under the brake caliper, and loosen the brake hose bolt and finally remove the brake hoses.

⚠ Caution

Do not spill brake fluid on painted surfaces.

Remove the bolt cap and loosen the lining guide bolts.

Remove two caliper bolts and the caliper.

Installation

Install the brake caliper and tighten the attaching bolts securely.

Torque: 3.3kgf-m

⚠ Caution

- Use M8 x 35 mm flange bolt only.
- Long bolt will impair the operation of brake disc.

Tighten the lining guide bolt.

Torque: 1.8kgf-m

Install bolt cap.

Torque: 1.0kgf-m

Use two seal washers and hose bolts to lock the hose and brake caliper in place.

Torque: 3.5kgf-m

Refill up the brake fluid to the reservoir and make necessary air bleeding.

11. BRAKE SYSTEM

Brake Disc

Inspection

Visually check the brake disc for wear or break. Measure the thickness of the disc at several places. Replace the disc if it has exceeded the service limit.

Allowable limit: 2.0 mm

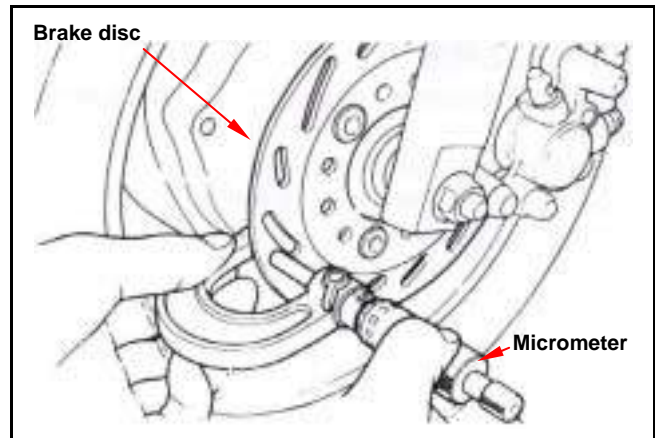

Remove the brake disc from wheel. Check the disc for deformation and bend.

Allowable limit: 0.30 mm

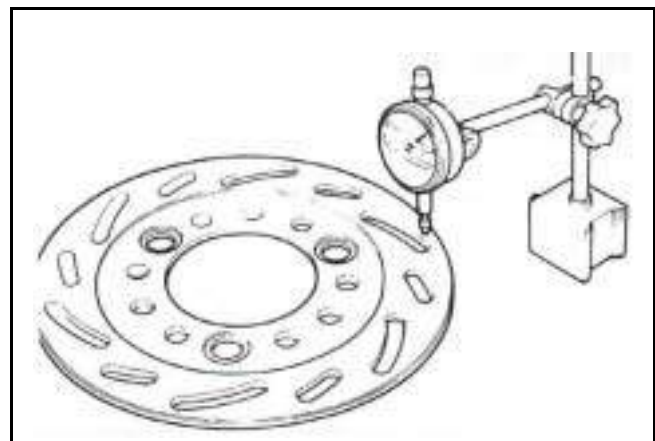

Disc Brake - Master Cylinder

Master Cylinder Removal

⚠ Caution

Do not let foreign materials enter into the cylinder.

⚠ Caution

The whole set of master cylinder, piston, spring, diaphragm and cir clip should be replaced as a set.

Remove the front and rear handlebar covers.
 Remove the leads of brake light switch.
 Drain out the brake fluid.
 Remove the brake lever from the brake master cylinder.
 Remove the brake hose.
 Remove the master cylinder seat and the master cylinder.
 Remove the rubber pad.
 Remove the cir clip.
 Remove the piston and the spring.
 Clean the master cylinder with recommended brake fluid.

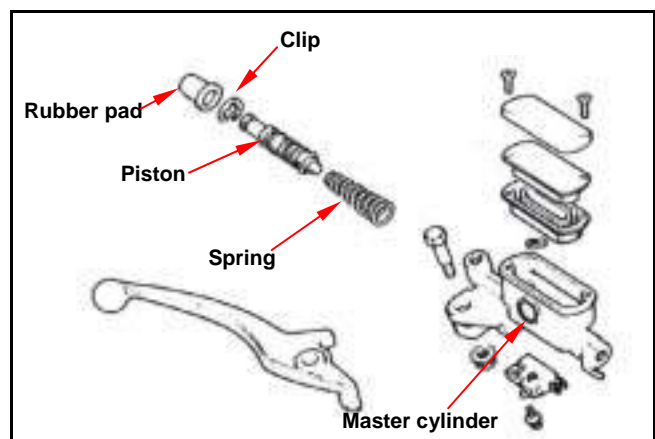
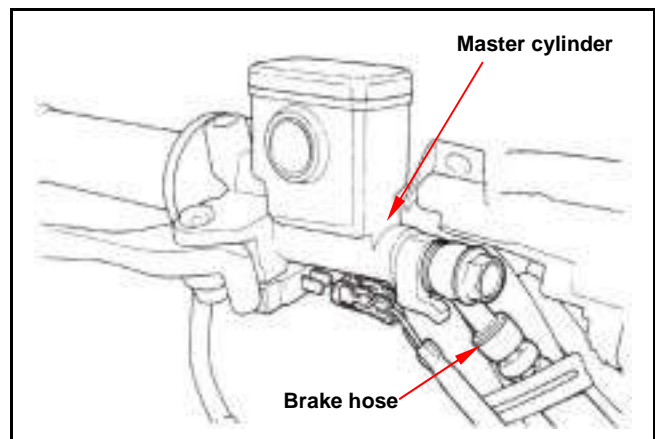

Master Cylinder Inspection

Check the master cylinder for damage or scratch.
Replace it if necessary.

Measure the cylinder inner diameter at several points along both X and Y directions.

Replace the cylinder if the measured values exceed allowable limit.

Allowable limit: 12.550 mm

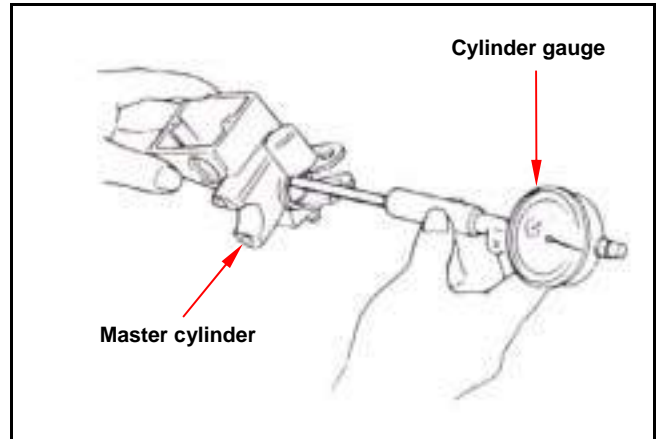

Measure the outer diameter of the piston.

Replace the piston if its measured value exceeds allowable limit.

Allowable limit: 12.654 mm

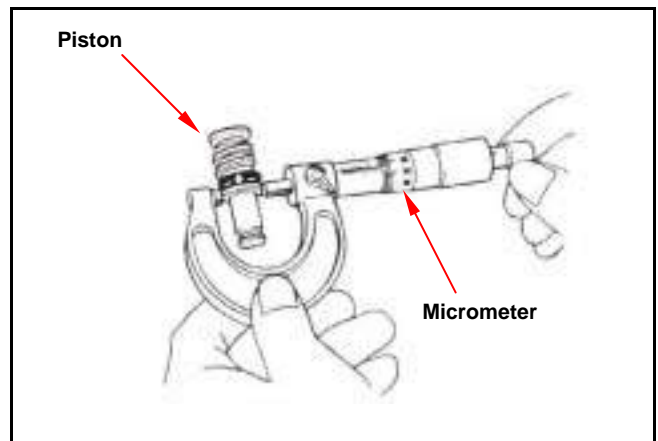

Master Cylinder Assembly

⚠ Caution

- It is necessary to replace the whole set comprising piston, spring, piston cup, and cir clip.
- Make sure there is no dust on all components before assembling.

Apply clean brake fluid to the piston cup, and then install the cup onto the piston.

Install the larger end of the spring onto the master cylinder.

The master cup's cavity should be face inside of master cylinder when installing the master cup.

Install the cir clip.

⚠ Caution

- Never install cup lip in the opposite direction.
- Make sure the cir clip is seated securely in the groove.

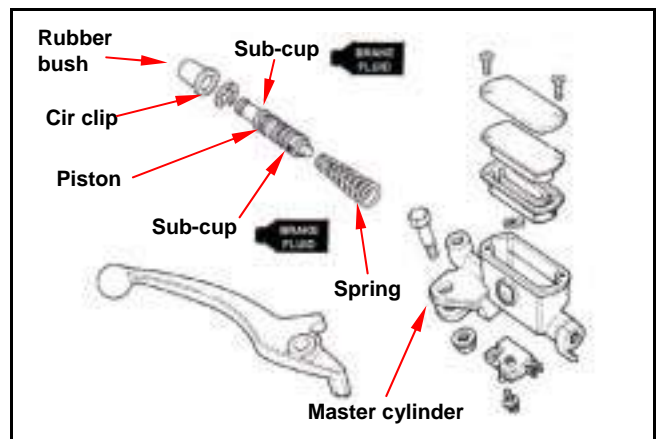

Install the rubber pad into groove properly.

11. BRAKE SYSTEM

Install the rubber pad into the groove correctly.
Place the master cylinder onto handlebar, and install the bolts.
Install the brake lever, and connect leads to brake light switch.

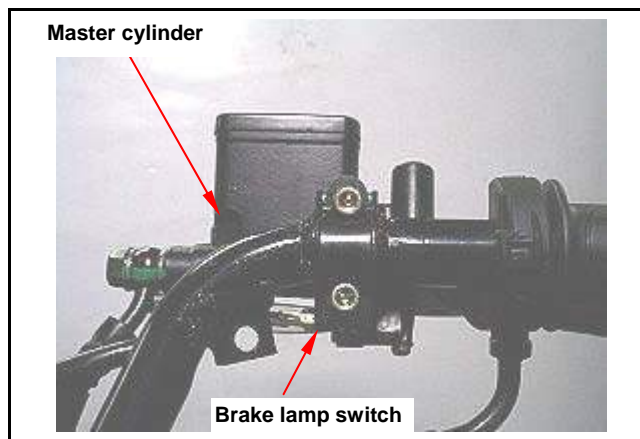

Connect brake hoses with 2 new washers.
Tighten the brake hose bolt to the specified torque value.

Torque: 3.5kgf-m

Make sure the hose is installed correctly.
Install all wires, hoses, and components carefully so avoid to twisting them together.

⚠ Caution

Improper routing may damage leads, hoses or pipes.

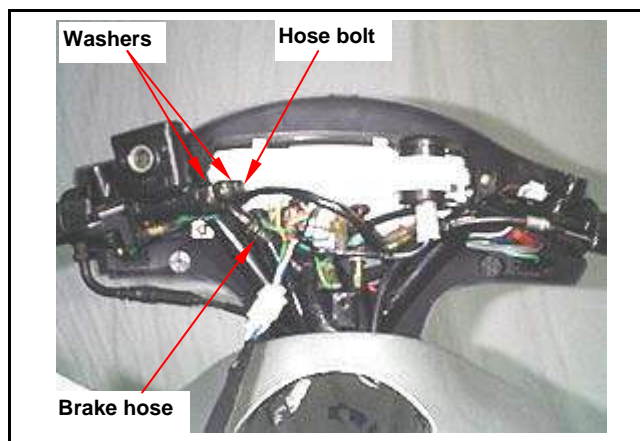

⚠ Caution

Kink of brake leads, hose or pipe may reduce brake performance.

Add specified brake fluid and bleed the system.

Drum Brake

To use vacuum cleaner or other alternatives to avoid danger caused from dusts.

⚠ Caution

- Inhaling brake lining ashes may cause disorders of respiration system, therefore, never use compressed air or dry brush to clean brake parts.
- Brake performance will be reduced by grease on brake lining.

Remove wheel and brake drum.

Inspection

Check brake drum for damage or wear out, and replace it if necessary.

Measure the inner diameter of brake drum and record the max. value.

**Allowable limit: Front (110.5mm)
Rear (95.5mm)**

⚠ Caution

- Clean the rust onto the brake drum with #120 sand-paper.
- Measure the inner diameter of brake drum with micrometer.

Measure the thickness of brake lining at three points (both ends and center).

If the thickness is less than specified value or if it is contaminated by oil or grease, replace as a set.

Service limit: Rear: 2.0 mm

Removal

⚠ Caution

Brake linings must be replaced as a shoes.

Remove the brake linings from brake panel.

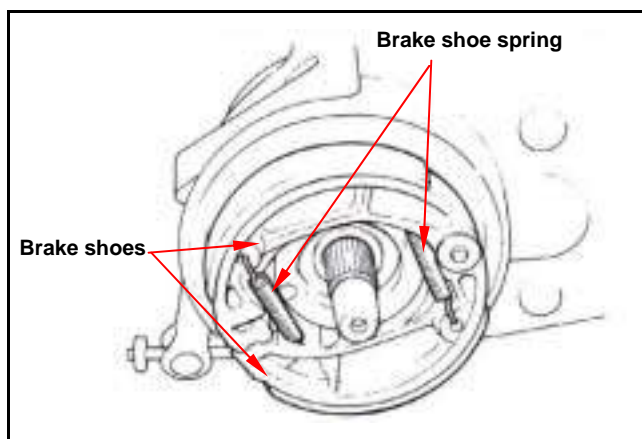
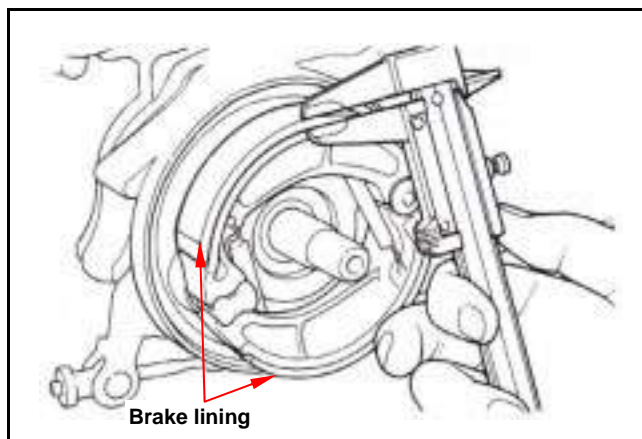
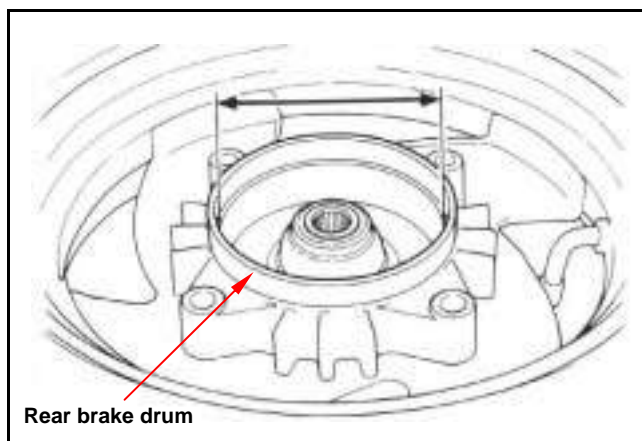
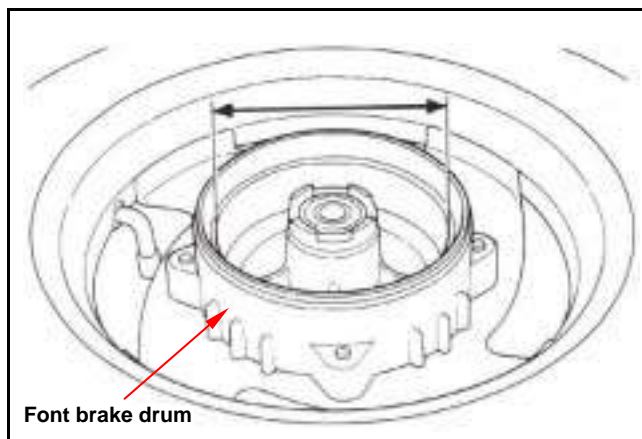

11. BRAKE SYSTEM

Installation

Apply with a thin coat of grease to the brake cam and the anchor pin.

Install brake cam.

Never allow brake linings to be contaminated by oil or grease.

Wipe off the excessive grease from brake cam and the anchor pin.

⚠ Caution

Brake efficiency will be reduced if brake linings is contaminated by oil or grease.

Install the brake cam and arm after aligning it with the punched point.

Tighten the bolts and nuts to specified torque:

Torque value: 0.5kgf-m

Use a brake cleaner to clean brake hub and replace the two brake shoes if brake linings are contaminated.

⚠ Caution

Brake efficiency will be reduced if brake linings is contaminated by oil or grease.

Install spring onto the brake shoes.

Install the brake shoes to the brake panel one after one, and make sure the shoe springs are in correct position.

Install the wheel.

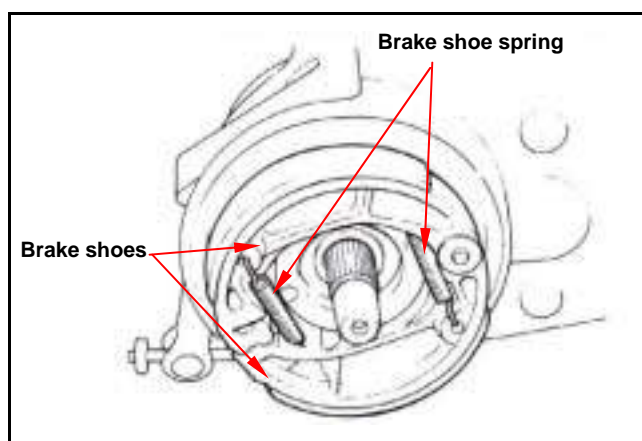
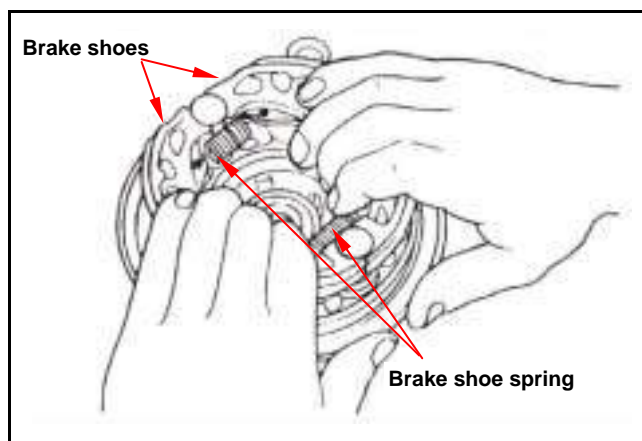
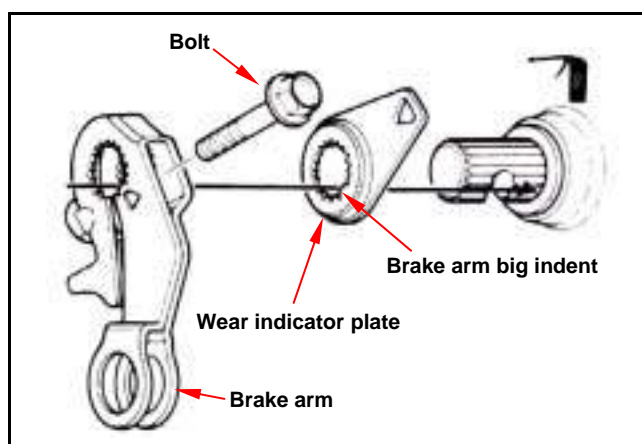
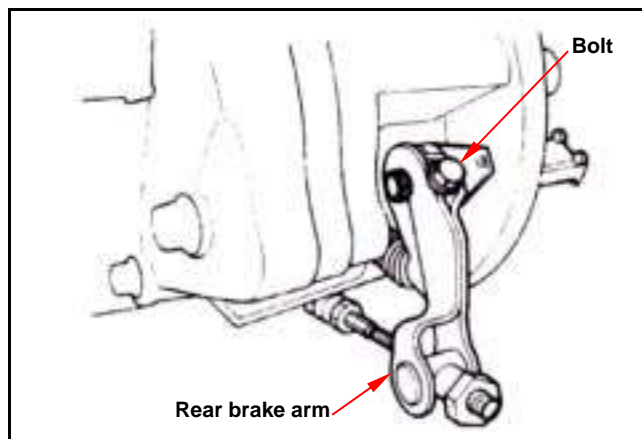

Body Overview	12-1	Front Under Spoiler	12-9
Maintenance Information	12-3	Front Inner Box	12-10
Side Covers	12-4	Floor Panel	12-11
Luggage Box	12-5	Front Fender	12-11
Body Cover	12-6	Steering Handle Cover	12-12
Front Cover	12-8	Under Cover	12-13

Body Overview (FT05U / FT05W)

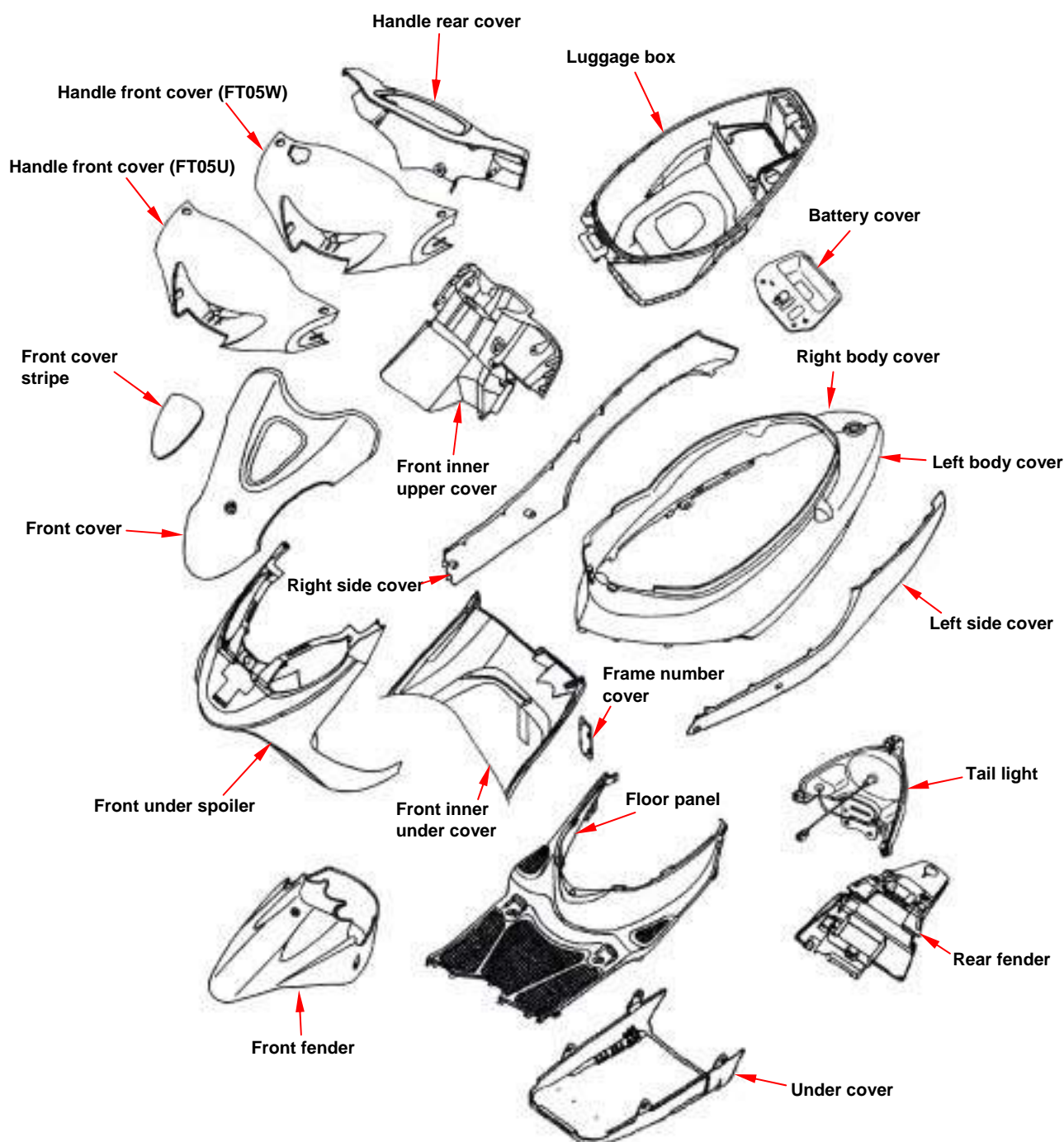

12. BODY COVER

Body Overview (FT05T / FT05V)

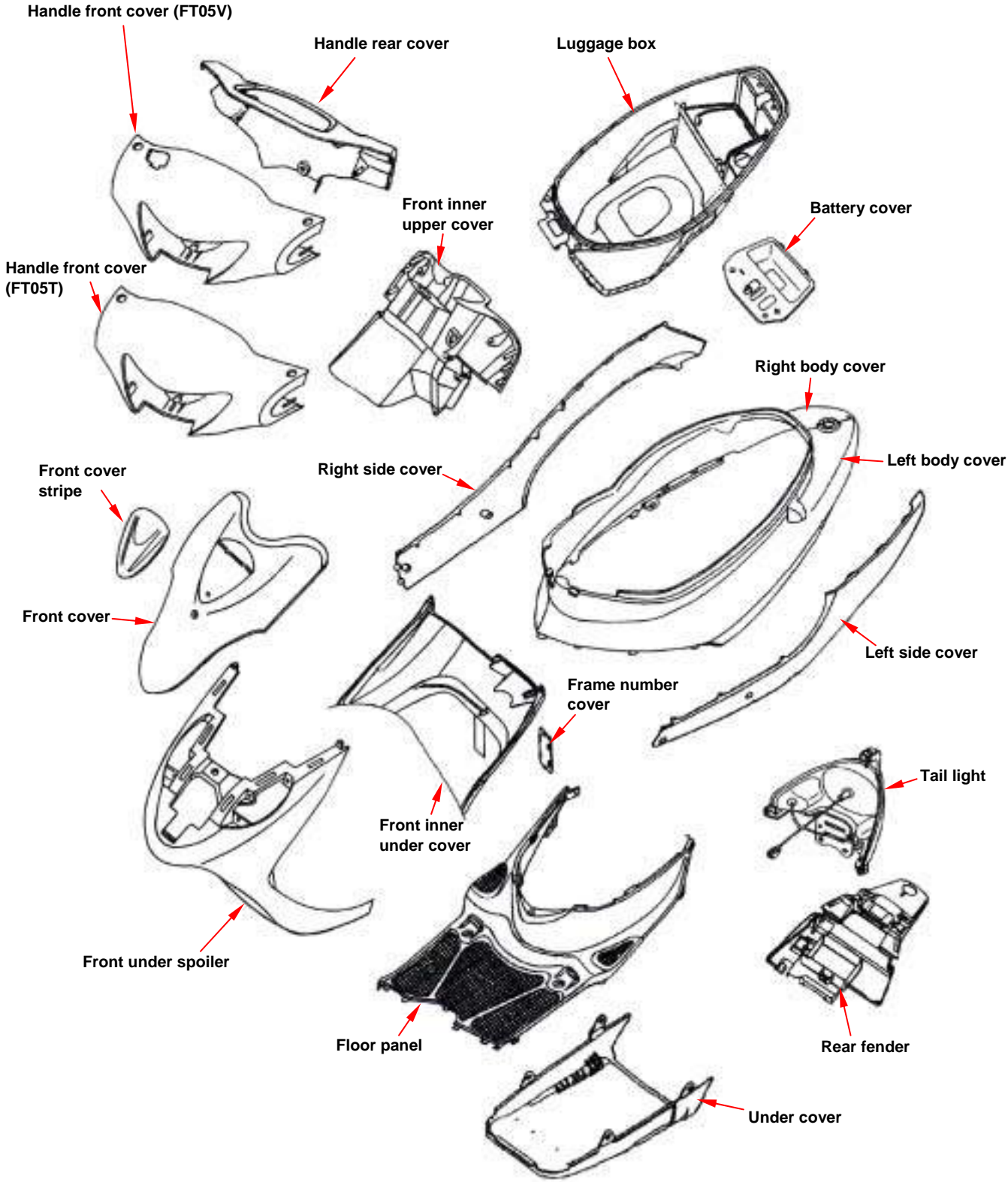

Maintenance Information

Body covers disassemble sequence:

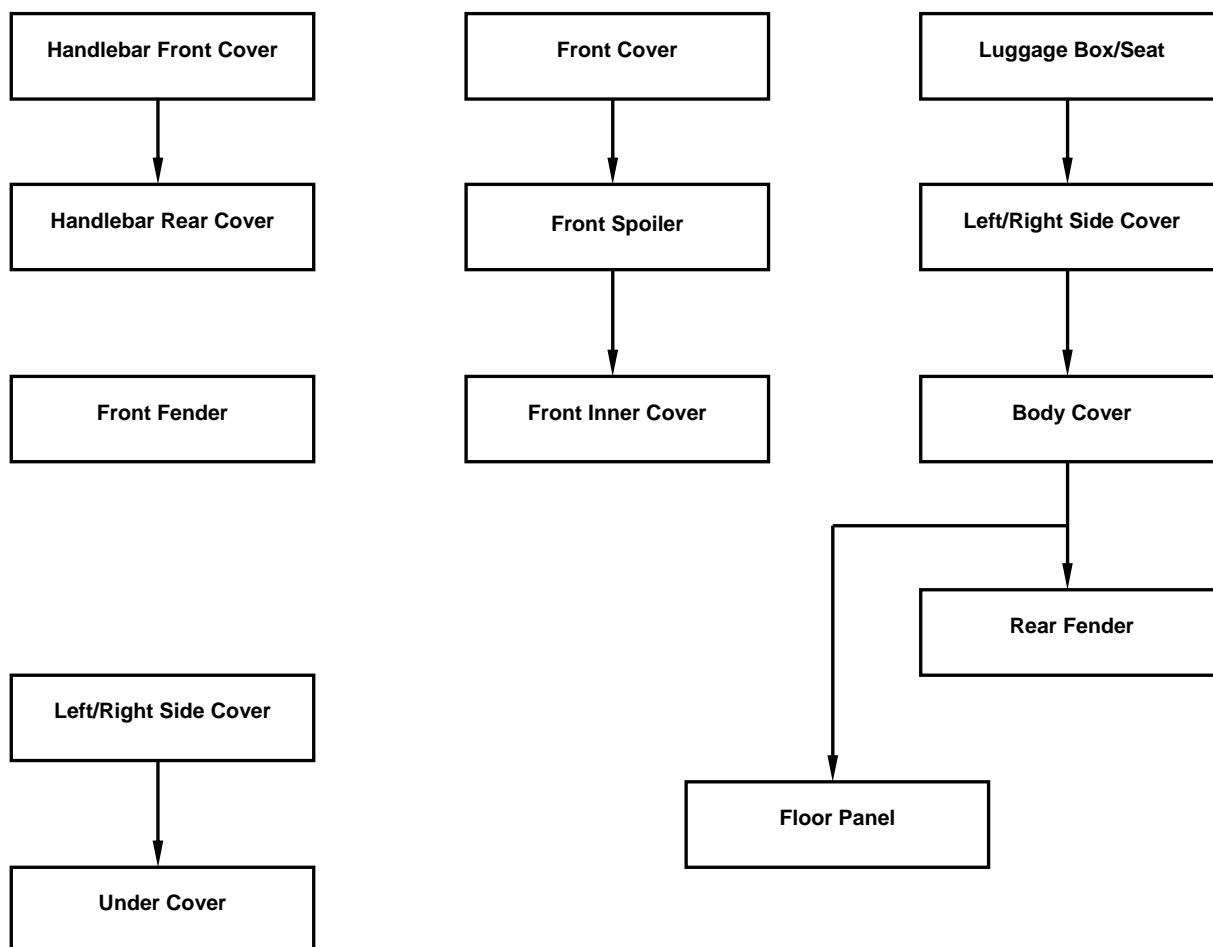

- Be careful not to damage various covers in disassembly or re-assembly operation.
- Never injure hooks molded on the body covers in disassembly or re-assembly operation.
- Align the buckles on the guards with slot on the covers.
- Make sure that each hook is properly installed during the assembly.
- Never compact forcefully or hammer the guard and the covers during assembly.

12. BODY COVER

Side Covers

1. Removal:

- Remove 2 screws (front/middle) from two side covers.



- Slide the side cover backward so that their hooks are out of slots.



- Take out the side cover end part and then remove the cover.



2. Installation:

- Install in reverse order of removal procedures.

Caution

The tail of each cover is held with buckles and slot, never pull them with force, or it would crack the buckles.



Luggage Box

1. Removal:

- Lift up seat cushion.
- Remove luggage box mounting screws (1 screw).
- Remove luggage box bolts (4 bolts)
- Remove oil tank cap and oil guide rubber.
- Hold the luggage box in both front and rear sides by two hands, and then lift up the box to remove it.

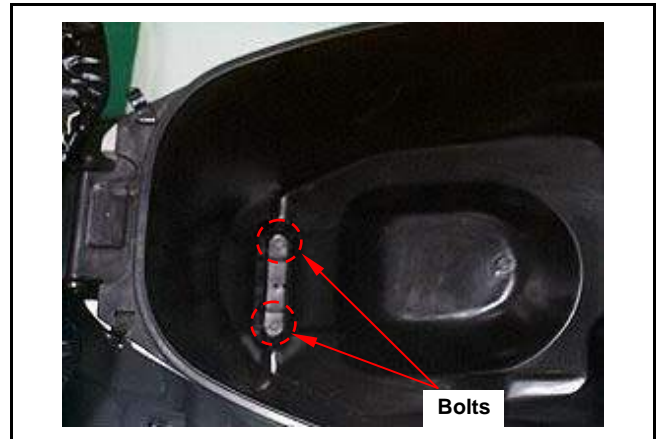

2. Installation:

- Install in reverse order of removal procedures.

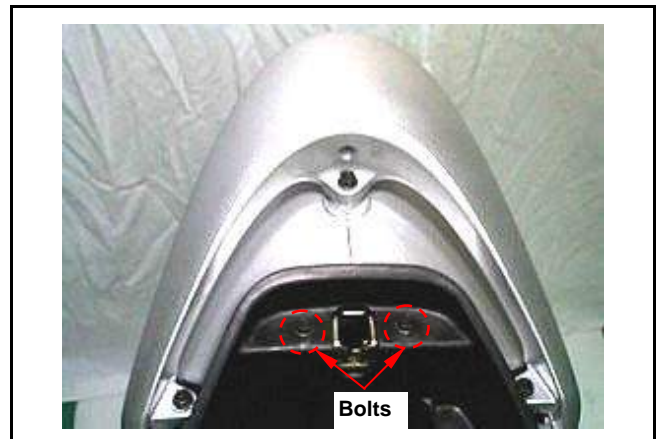

12. BODY COVER

Body Cover

1. Removal:

- Remove 3 bolts from rear carrier, and then remove rear carrier.

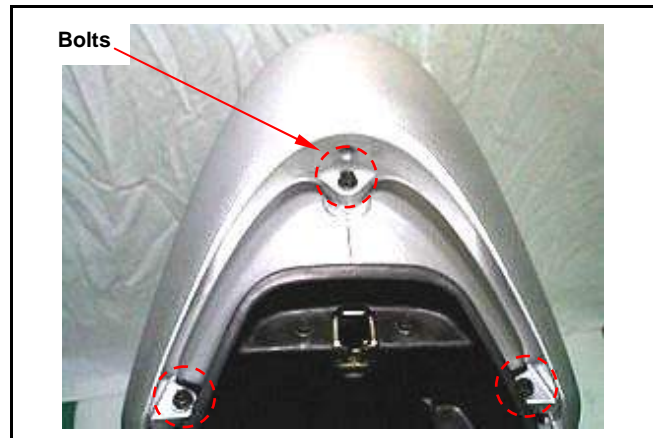

- Remove the luggage box.



- Remove 4 screws from the two side cover, and then remove the side cover.



- Remove 4 screws from the both sides.

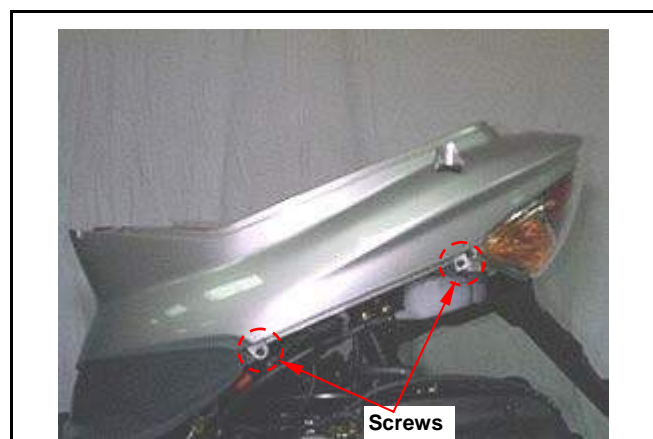

- Remove 1 screw from the front side.

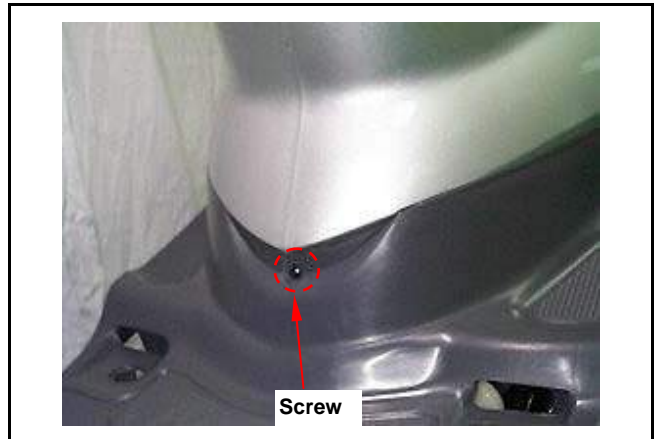

- Remove the body cover.



2. Installation:

- Install in reverse order of removal procedures.

12. BODY COVER

Front Cover

1. Removal:

- Remove 2 screws from the inner cover and front cover.



- Remove 1 screw from the front cover.

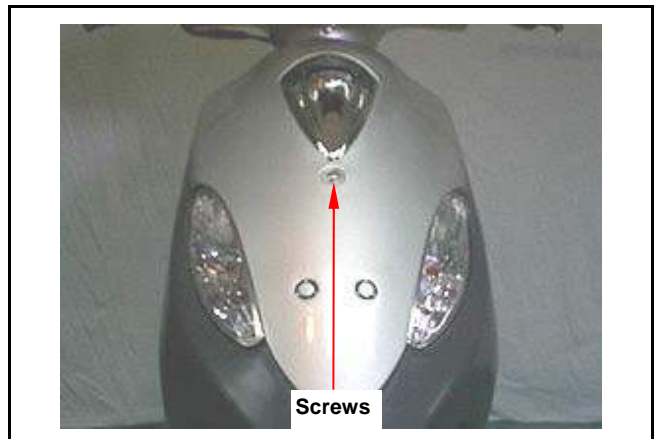

- Push the front guard up and then remove it.



2. Installation

- Install in reverse order of removal procedures.

Front under Spoiler

Removal:

- Remove the front cover and right / left side cover.
- Remove 4 screws from the front inner box.
- Remove 2 screws from the front upper part of the front spoiler and the front inner box.
- Remove front wheel bolt and wheel.
- Remove 2 screws from the lower part of the front spoiler.
- Remove the front spoiler.

2. Installation:

- Install in reverse order of removal procedures.

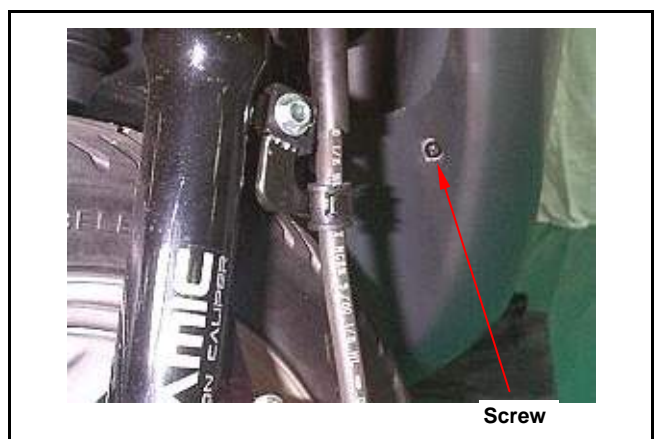
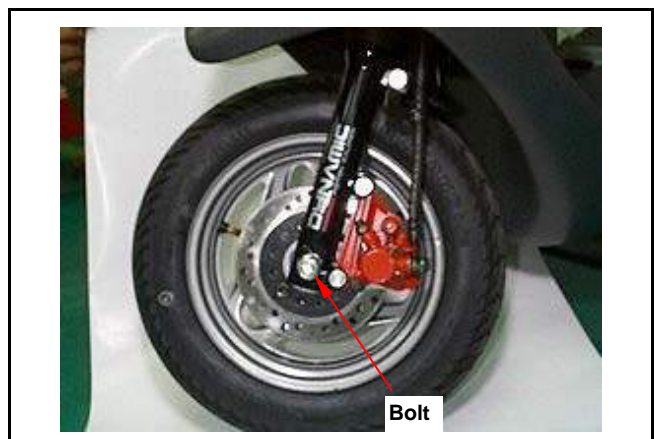
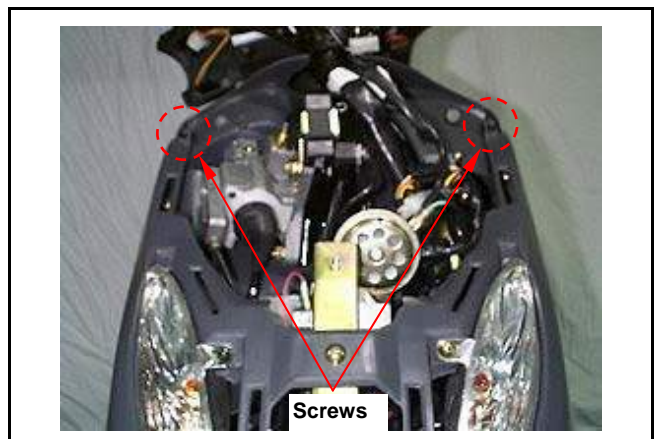
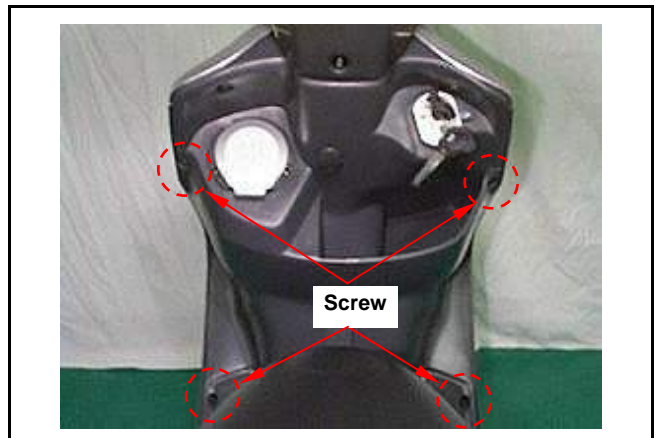

12. BODY COVER

Front Inner Box

1. Removal:

- Remove the front cover.
- Remove the front under spoiler.
- Remove 2 bolts from the floor panel.

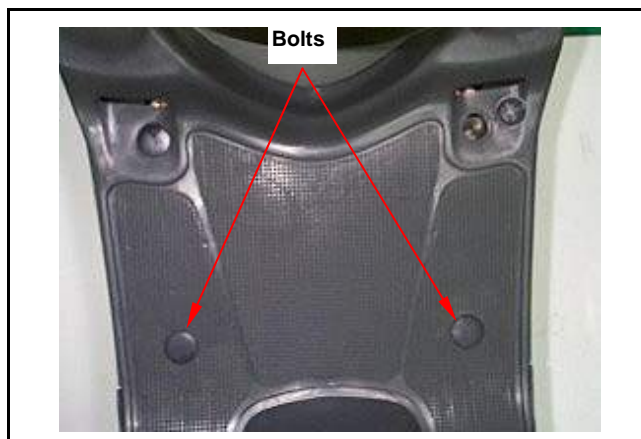

- Remove 5 screws of the fuel filling cap.

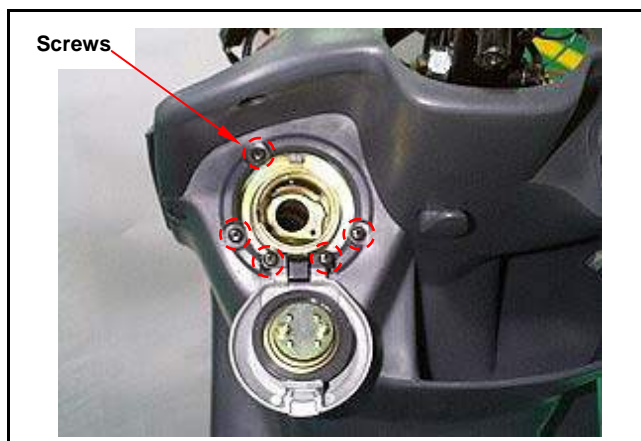

- Remove hook and 1 screw.

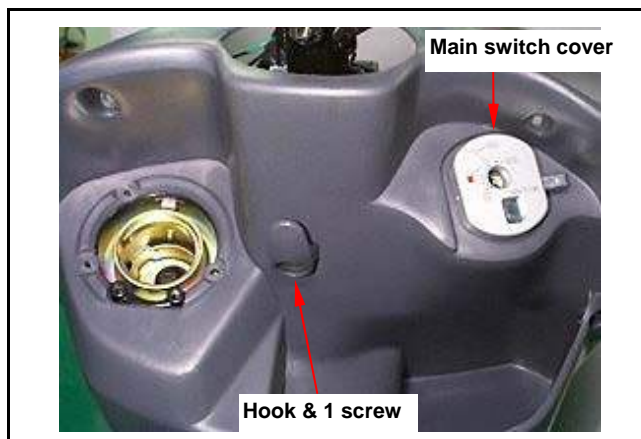

- Remove 1 screw from main switch cover.
- Remove main switch cover.
- Remove the front inner box.

2. Installation:

- Install in reverse order of removal procedures.

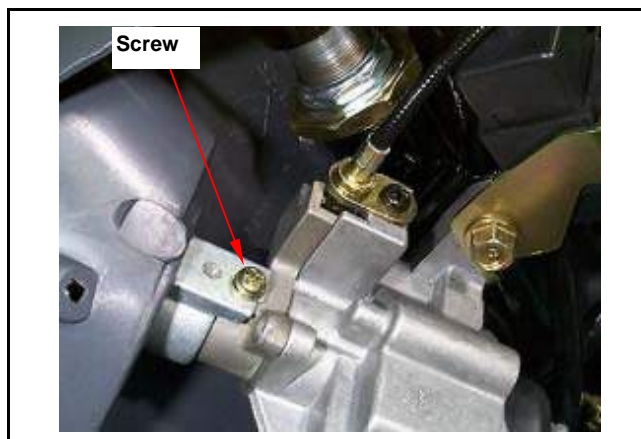

Floor Panel

1. Removal:

- Remove the luggage box, rear carrier, right / left side covers and body cover.
- Remove 4 plugs of the floor panel.

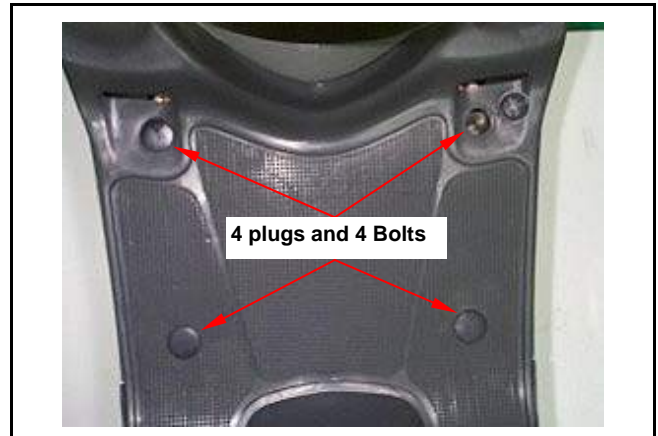

- Remove the floor panel. (4 bolts)

2. Installation:

- Install in reverse order of removal procedures.



Front Fender

1. Removal:

- Remove speedometer cable screw and cable.
- Remove front wheel bolt and then remove the wheel.
- Remove 3 screws of front fender.
- Remove the front fender.



2. Installation:

- Install in reverse order of removal procedures.

12. BODY COVER

Steering Handle Cover

1. Removal:

- Remove 1 screw under front light.



- Remove 3 screws from the handle rear cover.
- Remove handle front cover.



- Remove 2 inner screws.
- Disconnect each switch connectors.
- Remove speedometer cable.
- Remove rear handlebar guard.
- Remove handle rear cover and meter.

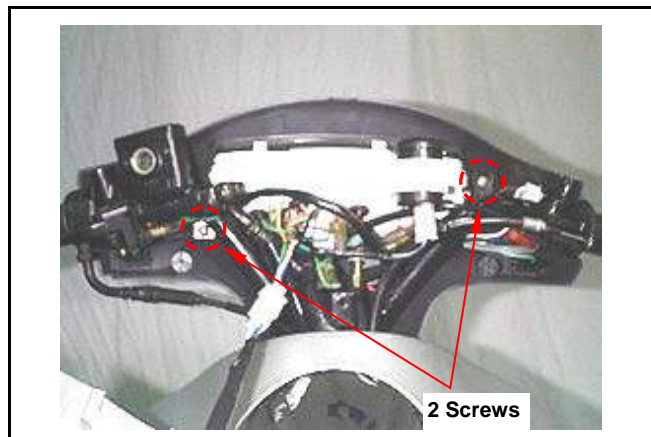

2. Installation:

- Install in reverse order of removal procedures.

Caution

Push the front connection part of rear handle cover at first when removing front cover so that the buckles are out of the cover. Never push it forcefully to cause buckles broken or cover damaged.

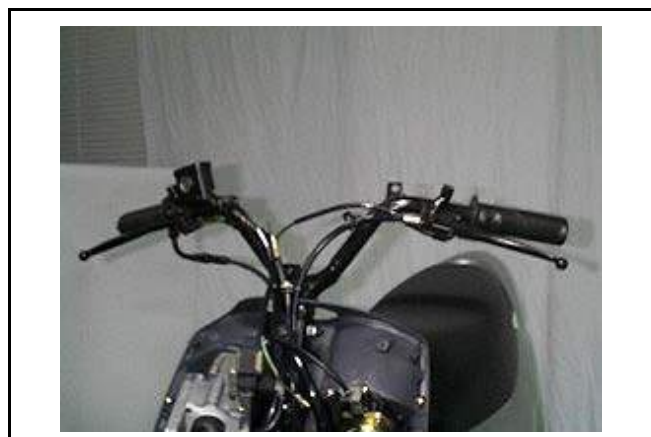

Under Cover**1. Removal:**

- Remove the right and left side cover.
- Remove 2 bolts from the under cover.
- Remove under cover.

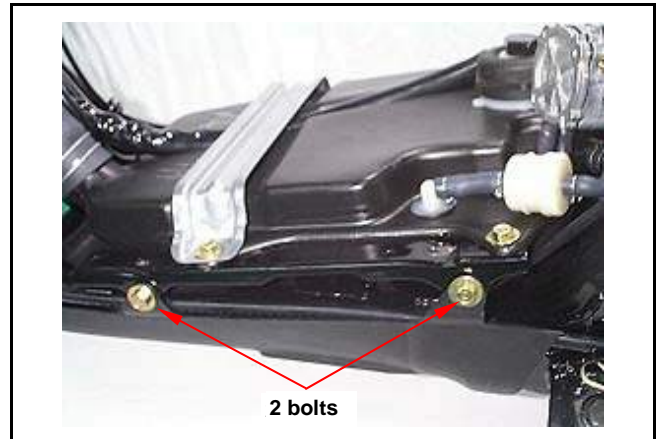
**2. Installation:**

- Install in reverse order of removal procedures.

12. BODY COVER



Note:



13. STEERING/FRONT WHEEL/SUSPENSION

Maintenance Information	13-2	Front Wheel	13-4
Troubleshooting	13-2	Front Shock Absorber	13-8
Steering Handle	13-3	Front Fork.....	13-9

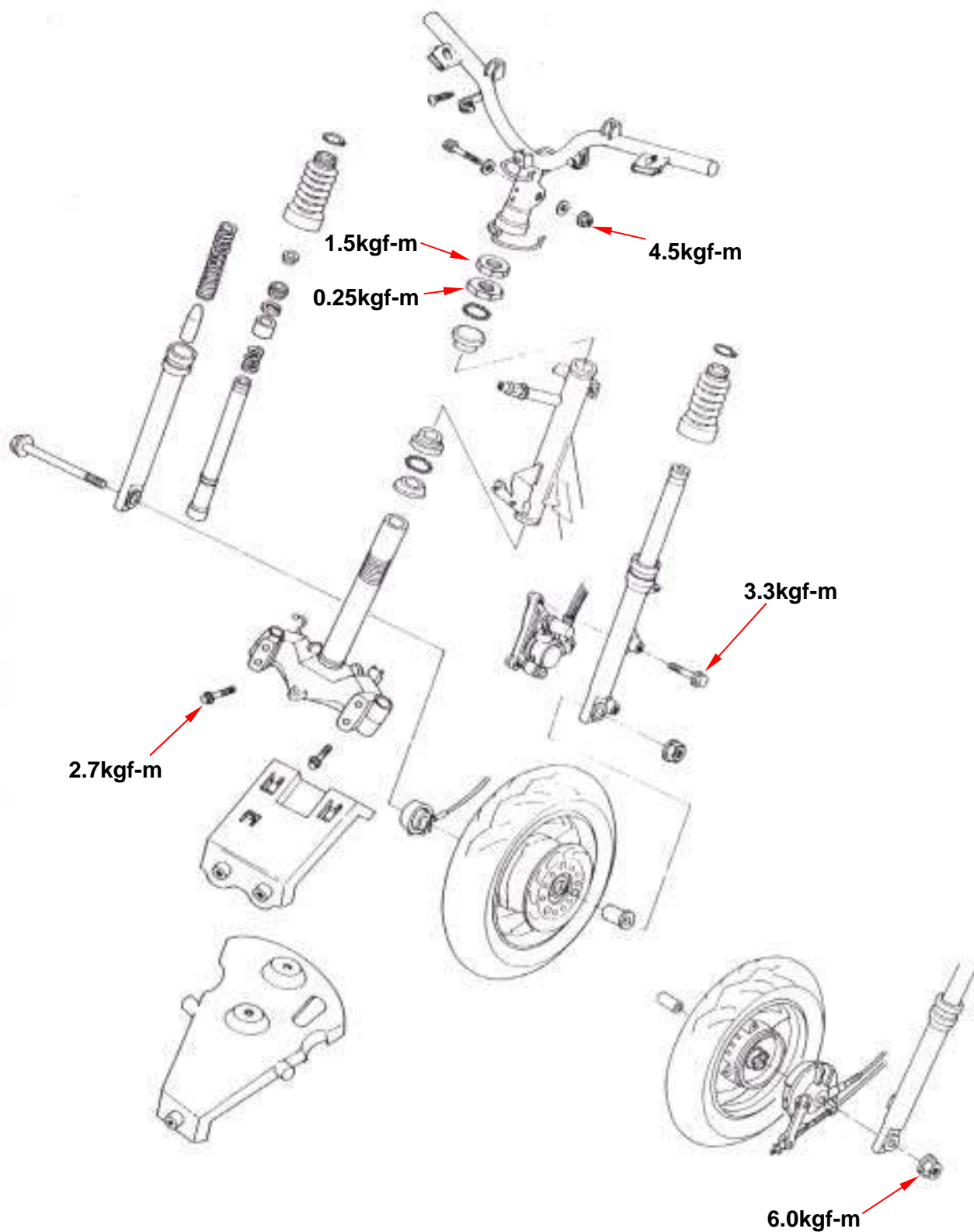

13. STEERING/FRONT WHEEL/SUSPENSION

Maintenance Information

Specification

Item		Standard value (mm)	Limit (mm)
Shaft bending			0.2 (0.01 in)
Rim wobbling	Radial		2.0 (0.08 in)
	Axial		2.0 (0.08 in)

Torque Value

Steering handle nut	4.5kgf-m	Front brake caliper bolt	3.3kgf-m
Front wheel axle	6.0kgf-m	Steering stem mounting nut	1.5kgf-m
Front shock absorber mounting nut	2.7kgf-m	Top cone race	0.25kgf-m

Special Tools

Inner bearing puller

Bearing driver

Troubleshooting

Hard To Steer

1. The steering shaft bolt is too tight.
2. The steering shaft bearing are damaged
3. The ball and the top cone of the steering shaft are damaged.
4. Insufficient tire pressure.

The Steering Handle Is Tilted

1. Uneven arrangement of the front shock absorbers.
2. The front fork is bent.
3. The front wheel axle is bent.

The Front Wheel Wobbling

1. The rim is bent.
2. The wheel axle nut is not tightened improperly
3. Bend wheel rim
4. Side-worn or poor tire.
5. The bearing play of the wheel axle is too large.

Soft Shock Absorber

1. Weak front shock absorber spring

Noise In Front Shock Absorber

1. Shock absorber outer tube noise
2. The joint of the shock absorber gets loose.

Steering Handle

Removal

Remove handle cover, front cover and inner box.
 Remove throttle grip after mounting screw removed.
 Remove master cylinder (**disc brake**) after 2 bolts removed.
 Remove rear brake lever bracket after mounting bolt removed.
 Remove handle mounting bolt and nut, and then remove the handle.

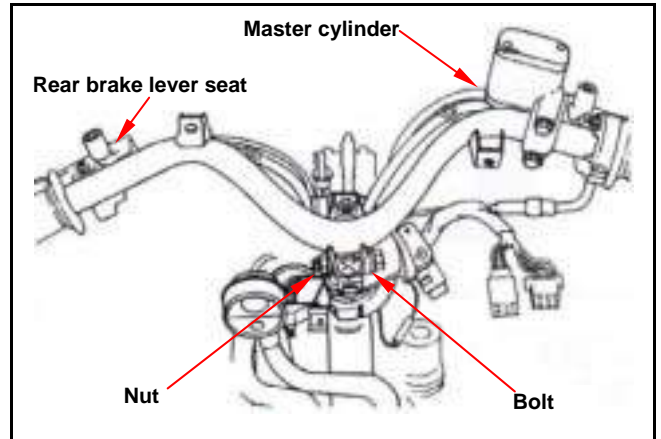

Installation

Install handle and align with bolt hole.
 Install bolt and nut and then tighten it.

Torque value: 4.5kgf-m

Apply with grease onto throttle cable and the sliding surface of handle.
 Align the lock pin of the handle outer tube with the hole on the handle, and then install the handle.
 Tighten the bolt.

⚠ Caution

Align the lock pin with the hole on the handle and also install brake lever seat. Then, tighten the lever with clamp and bolt.

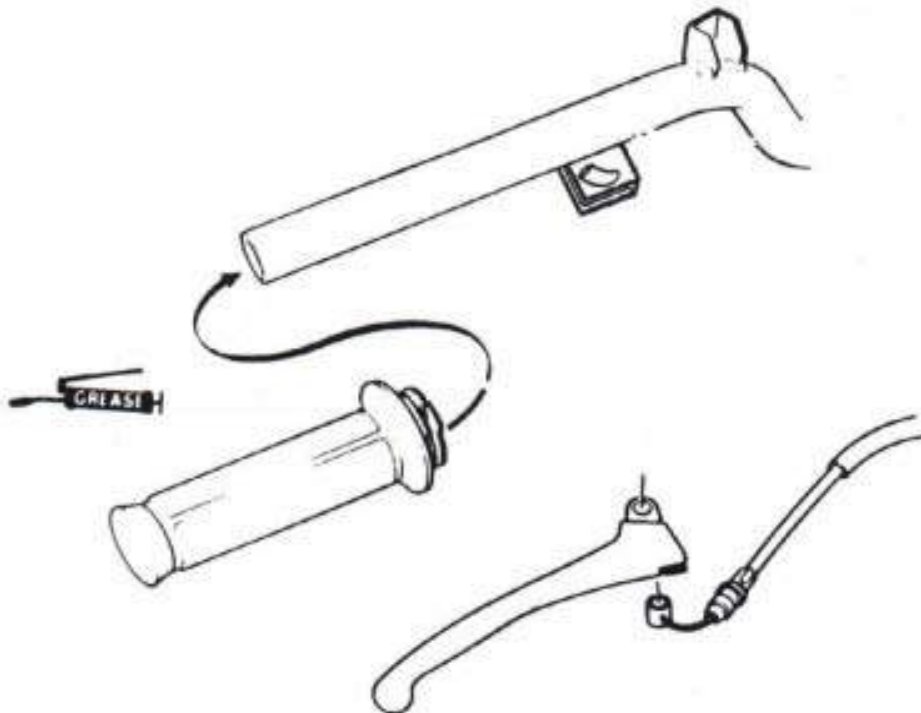

13. STEERING/FRONT WHEEL/SUSPENSION

Place master cylinder onto handle and align its connection surface with bolt hole on the handle **(disc brake)**.

Install the mounting seat.

Tighten the upper part bolt, and then tighten lower bolt.

Install all components in reverse order of removal procedures.

Conduct following adjustment:

- Oil pump control cable.
- Throttle operation.

Brake lever free play

Front Wheel

Removal

Remove speedometer cable from speedometer gear box.

Remove front brake cable. (Drum type)

Remove front wheel axle nut, and then pull out the axle and remove the wheel.

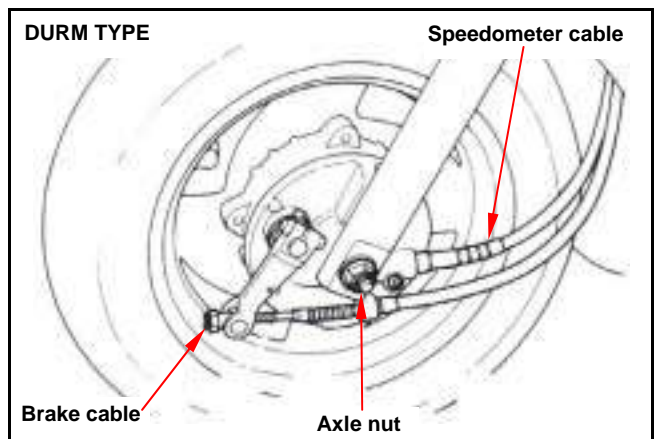
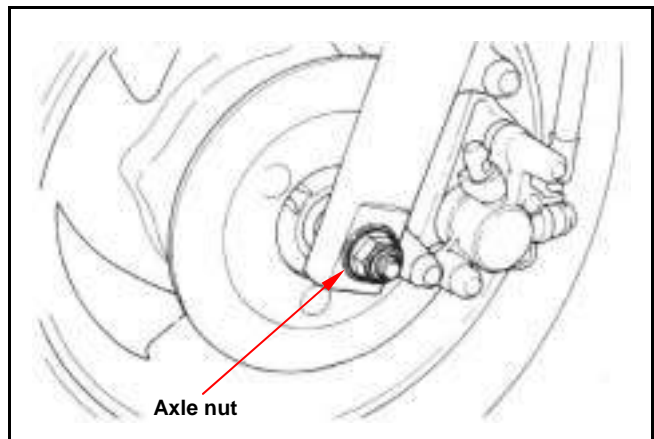
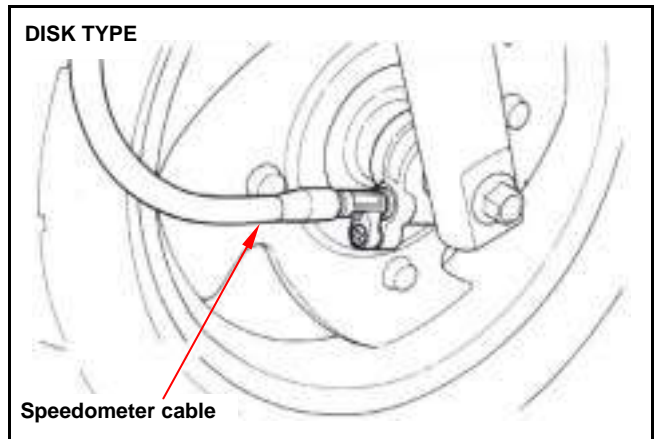
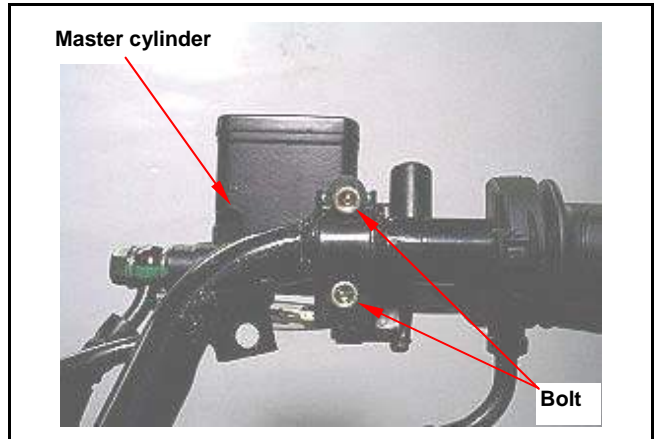

Inspection

Place the axle onto a V-block to measure its run-out with a dial gauge.

The dial gauge indicated 1/2 run-out.

Service limit: 0.20 mm

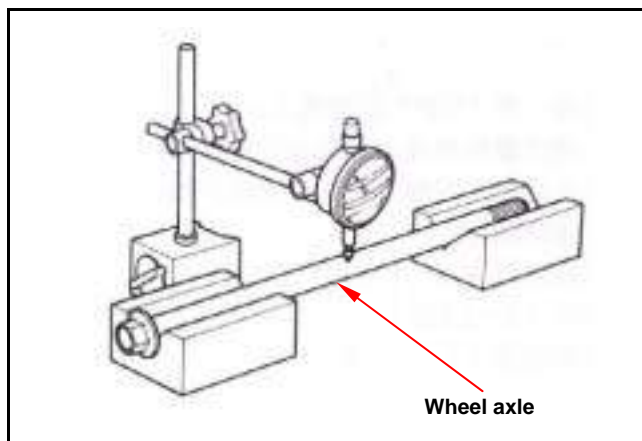

Place the wheel on to a rotation seat, and turn the wheel to check its bearing free play. If the bearing is noisy or its free play is too much, replace it.

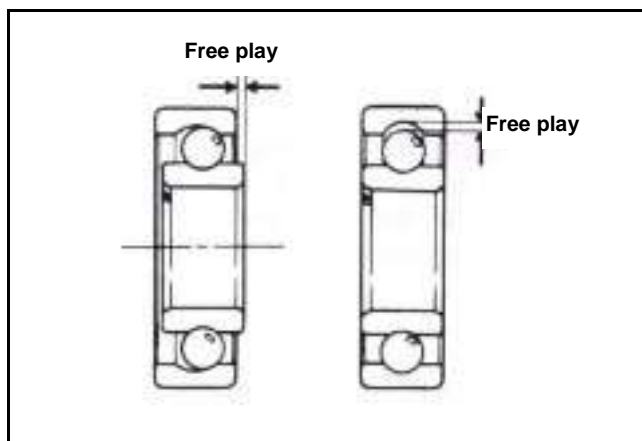

Place the wheel on to a rotation seat to check its rim wobbling. Turn the wheel with hand and measure its rim wobbling value with a dial gauge.

Service limit:

Radial: 2.0 mm (0.08 in)

Axial: 2.0 mm (0.08 in)

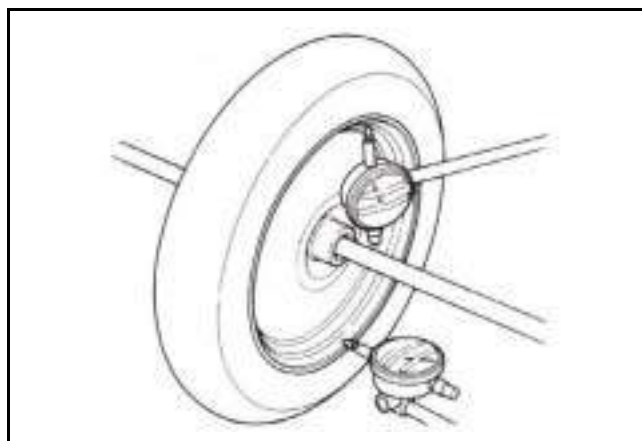

Remove 3 bolts and brake disc.

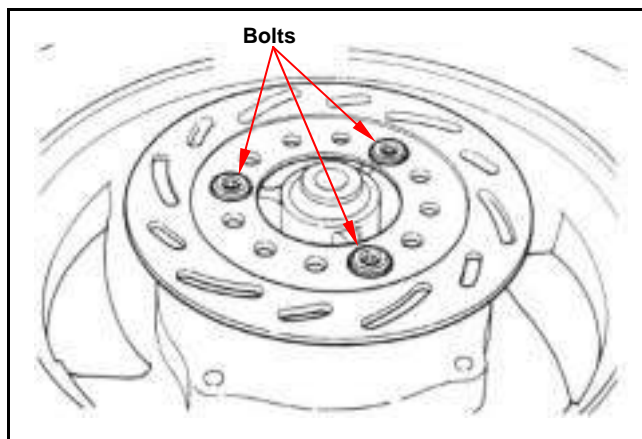

13. STEERING/FRONT WHEEL/SUSPENSION

Remove wheel hub from wheel rim after 4 nut removed.

Remove dust seal, bearing and side collar.

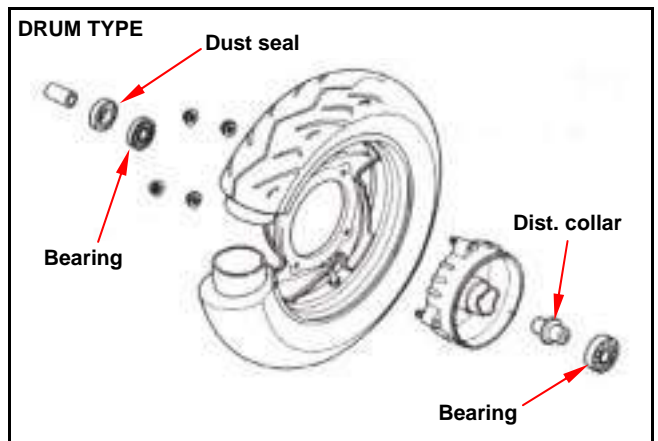
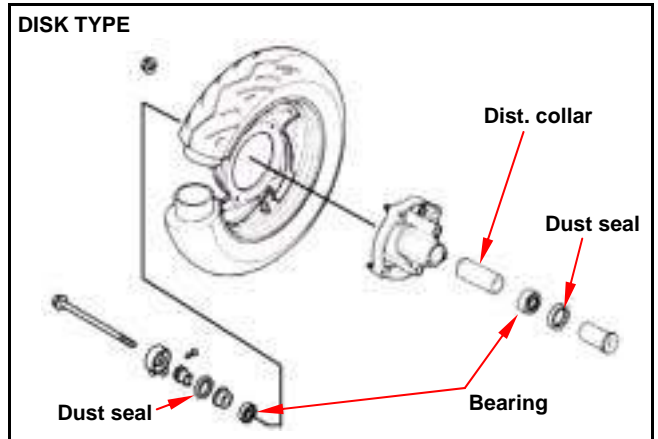

Special tools

Inner bearing puller (SYM-6204020)

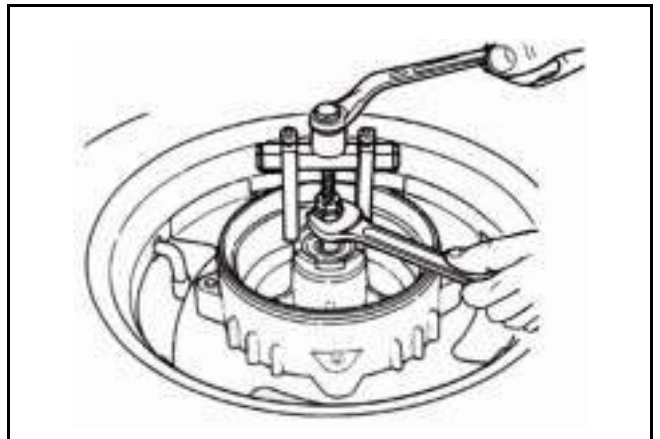

Installation

Fill out the block of bearing by grease.

Drive the left bearing and install the dist. collar.

Install the right bearing.

⚠ Caution

- Carefully install the bearing in correct and evenly.
- Bearing outer face should be faced up as bearing installation.

Install the brake disc and then tighten the bolts
(disc brake).

Torque value: 4.5kgf-m

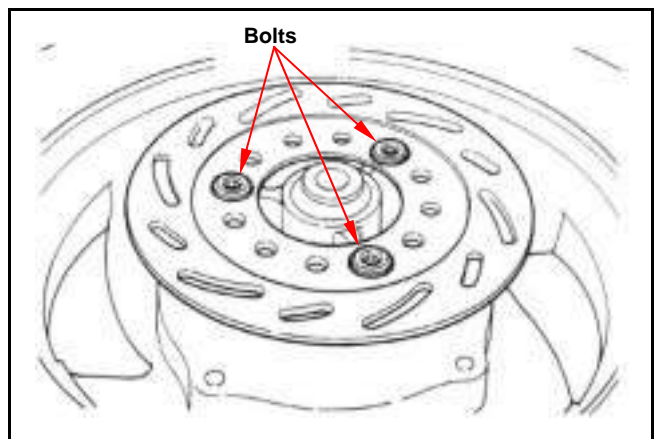

Lubricate the speedometer gear with grease and install the gear into the wheel hub. (Drum type)
Lubricate the speedometer gear box with grease (Disk type)

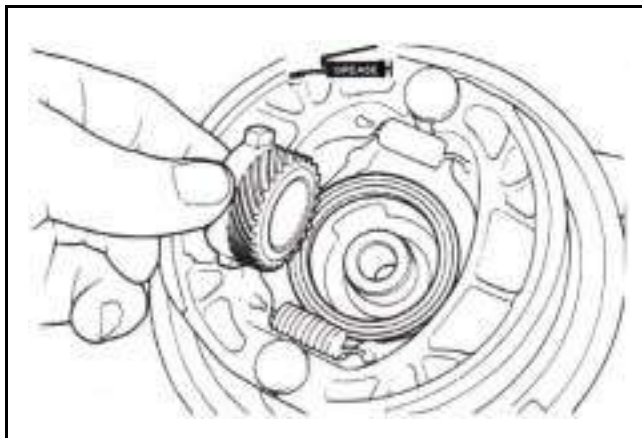

Align the flange part on the speedometer gear with the slot of wheel hub.

⚠ Caution

Contaminated brake lining will reduce brake performance so the brake lining, brake drum and disc must be free of grease.

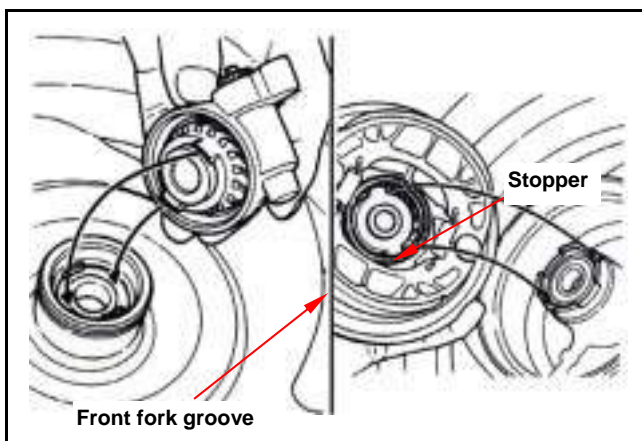

Apply with grease onto the dust seal.
Install the dust seal and side collar.
Place the front wheel between the front shock absorbers.

⚠ Caution

Align the brake disc groove with the stopper flange.

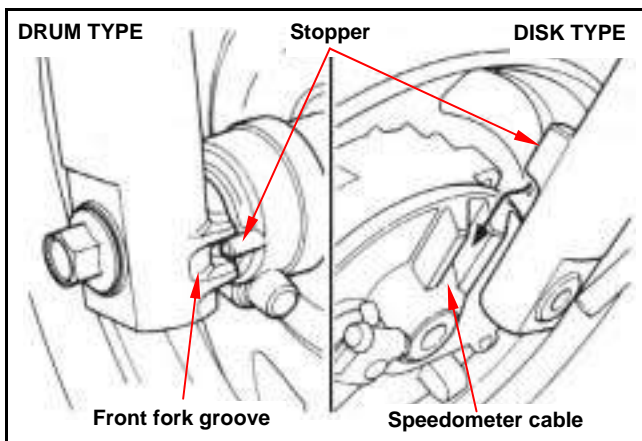

Insert the wheel axle into the wheel and the install the wheel axle nut.

Tighten the nut to specified torque.

Torque value: 6.0kgf-m

Connect the speedometer cable to the speedometer gear.

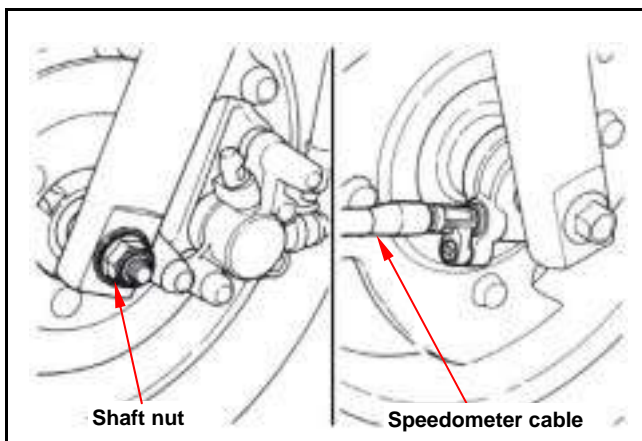

13. STEERING/FRONT WHEEL/SUSPENSION

Front Shock Absorber

Removal

- Front cover
- Front under spoiler
- Front fender
- Front wheel

Disc Brake

Remove the caliper mounting bolts and the caliper.

Take out the hose from hose clamp.

Remove the hose clamp mounting bolt and the clamp.

Drum Brake

Remove the cable clamp mounting bolt and the clamp.

Remove the front shock absorber upper bolt and the shock absorber.

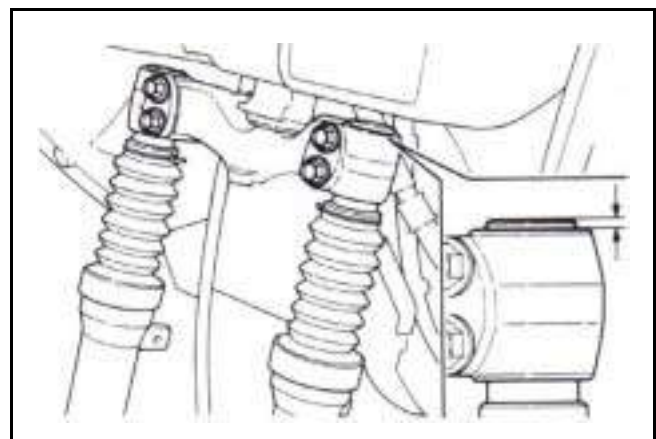
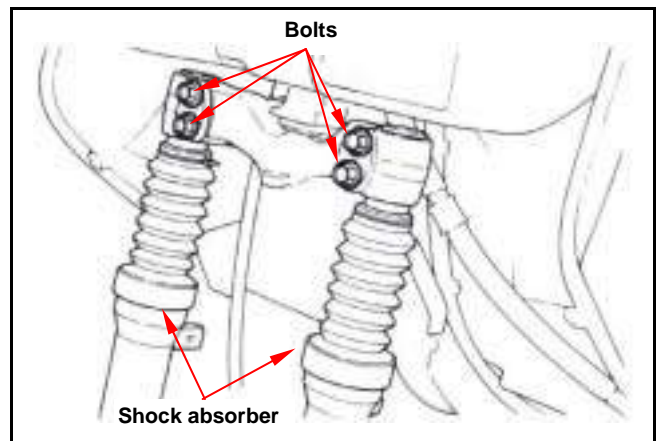
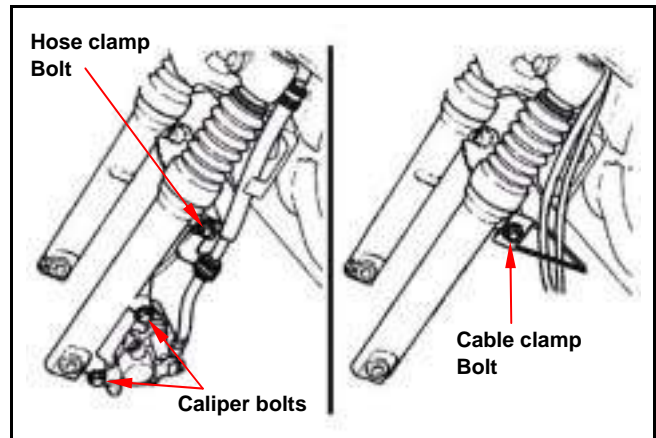

Installation

Align the cover flange with upper level of the shock absorber clamp, and then tighten bolts.

Torque value: 2.7kgf-m

Install the removed components in reverse order of removal procedures.

Front Fork

Removal

- Handle
- Front wheel
- Front shock absorber

Remove the steering stem mounting nut.

Remove top cone race and front fork.

⚠ Caution

Place the steel ball onto a parts container to prevent from missing.

Slightly tap the top and bottom ball bearing seats with a plastic hammer to remove the seats.

Remove bottom cone race body with a punch.

⚠ Caution

Do not damage the steering stem.

Installation

Install a new bottom cone race onto the steering stem.

Push the cone race until to mounted position.

⚠ Caution

Do not tilt the ball bearing seats as installation.

Apply with grease onto the ball bearing seats, and install steel balls onto the seats.

(Top: 26 balls, bottom: 29 balls)

Lubricate the top cone race seat with grease.

Screw the cone race in to top ball bearing seat till touching, and then screw out the cane race 1/4~3/8 turns.

Torque value: 0.25kgf-m

⚠ Caution

Check the steering stem that should be rotated freely and no clearance in vertical direction.

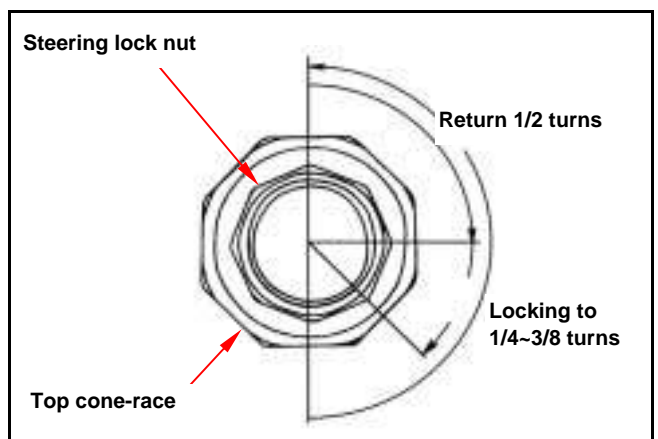
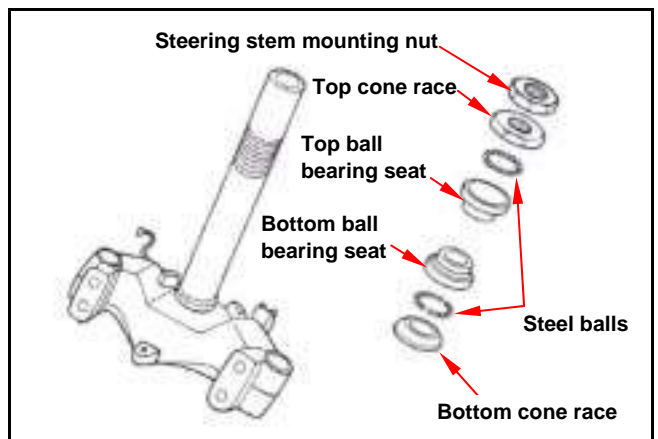
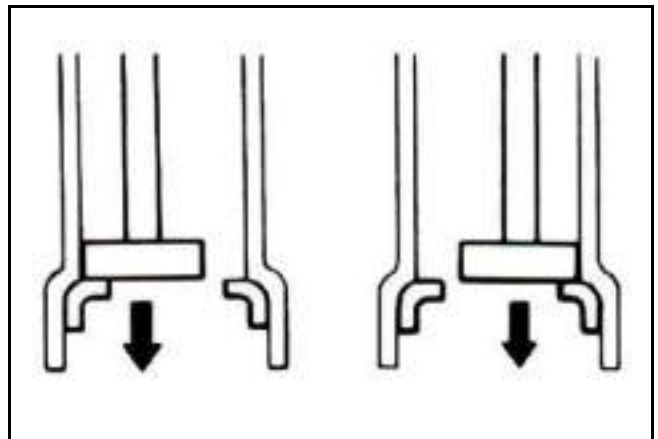
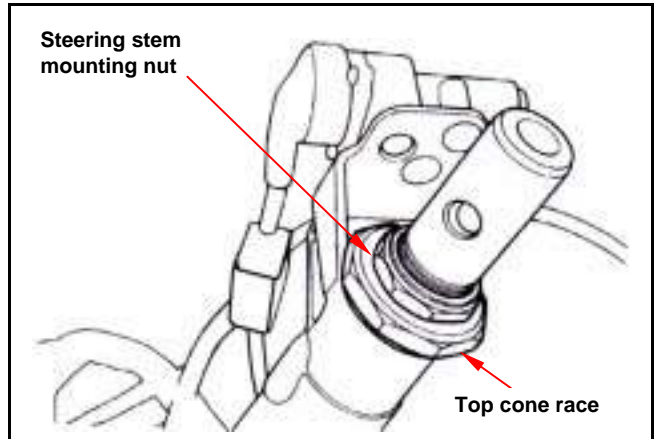

13. STEERING/FRONT WHEEL/SUSPENSION

Install the steering stem mounting nut and tighten the nut by means of holding the top cone race body.

Torque value: 1.5kgf-m

Install in reverse order of removal procedures.

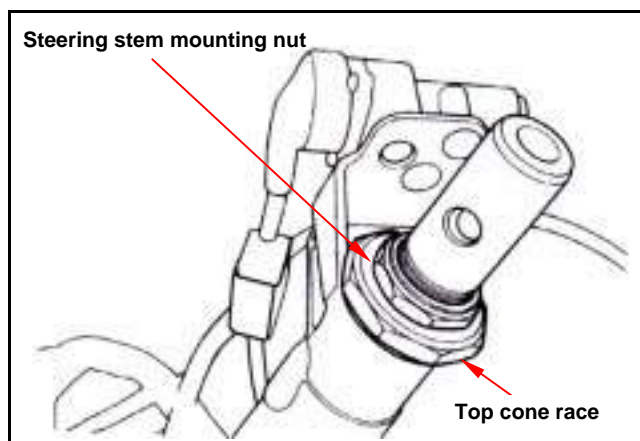

Maintenance Information14-2
Troubleshooting14-2

Rear Wheel 14-3
Rear Shock Absorber 14-4

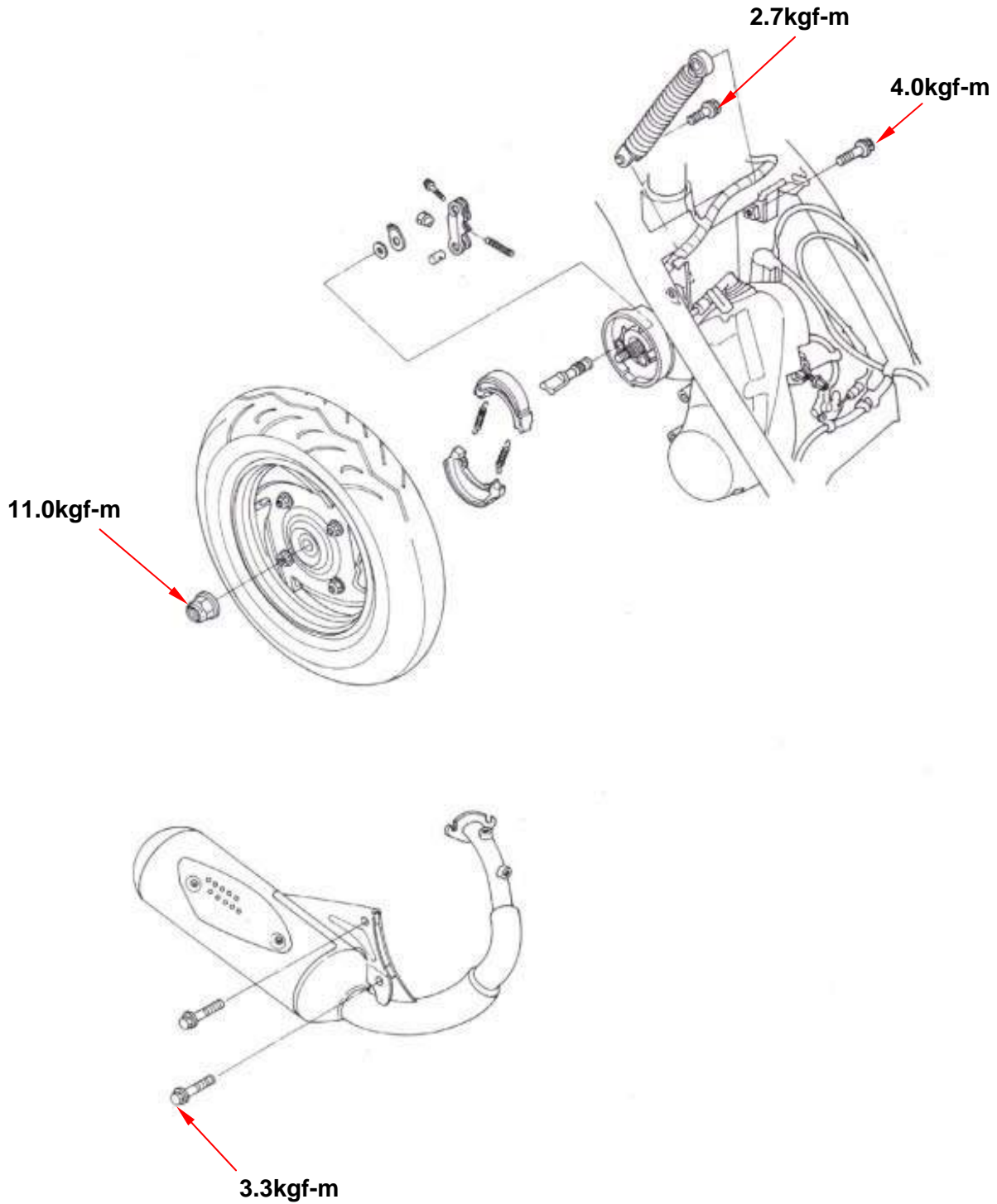

14. REAR WHEEL/SUSPENSION

Maintenance Information

Specification

Item	Standard value (mm)	Limit (mm)
Rear wheel rim run out	-	2.0 (0.08 in)

Torque Value

Rear shock absorber upper mounting bolt: 4.0kgf-m

Rear shock absorber lower mounting bolt: 2.7kgf-m

Rear wheel nut: 11.0kgf-m

Rear wheel hub: 2.5kgf-m

Exhaust muffler nut: 1.2kgf-m

Exhaust muffler bolt: 3.3kgf-m

Troubleshooting

Rear wheel wobbling

1. Bend wheel rim
2. Poor tire
3. Loosen wheel shaft

Shock absorber too soft

1. Insufficient shock absorber spring force

Poor brake performance

1. Poor brake adjustment
2. Contaminated brake lining
3. Worn brake lining cam
4. Worn brake cam lever
5. Worn brake drum
6. Improper installation of brake arm gear set.

Rear Wheel

Remove

Remove exhaust pipe nut. (2 connection nuts)
 Remove exhaust muffler bolt (2 bolts), then
 remove the muffler.

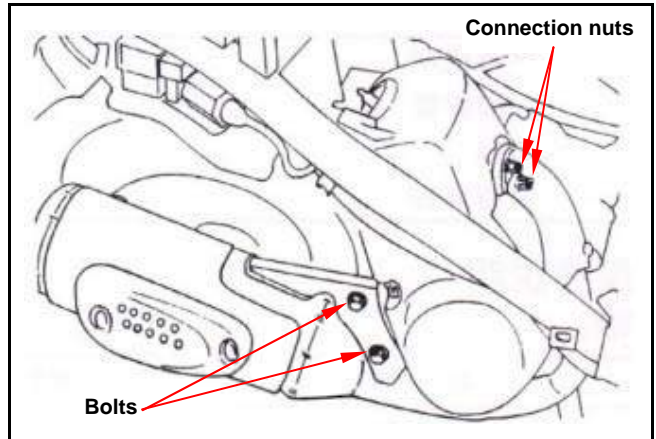

Remove rear wheel shaft nut and then remove
 the rear wheel.

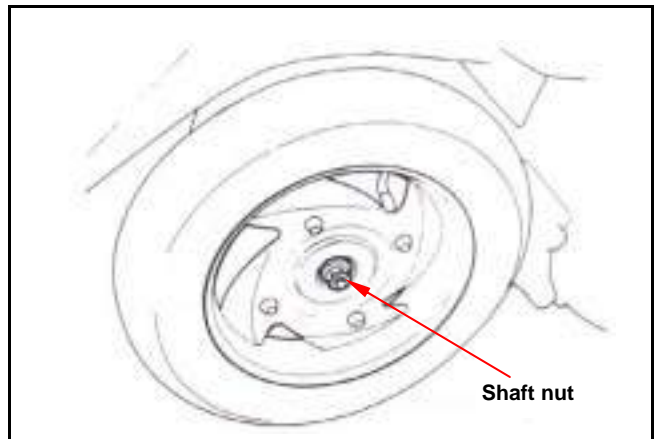

Inspection

As the diagram shown, measure wheel rim
 wobbling with a dial gauge.

Service limit:

Radial: 2.0 mm (0.08 in)

Axial: 2.0 mm (0.08 in)

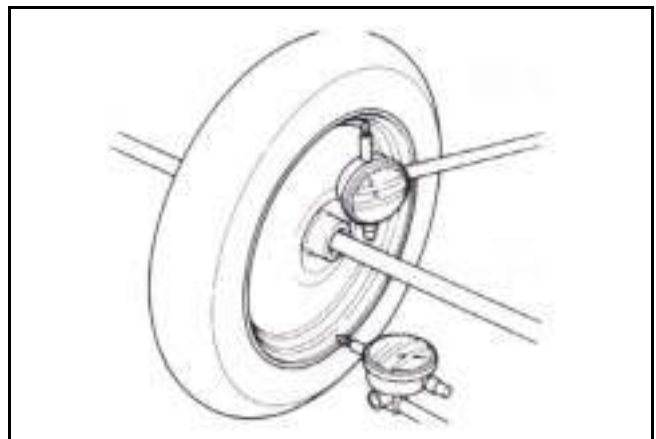

Brake Hub Replacement

Remove 4 nuts of cover and wheel rim, and then
 remove the wheel hub.

Install the wheel hub and tighten the nuts.

Tighten torque: 2.5kgf-m

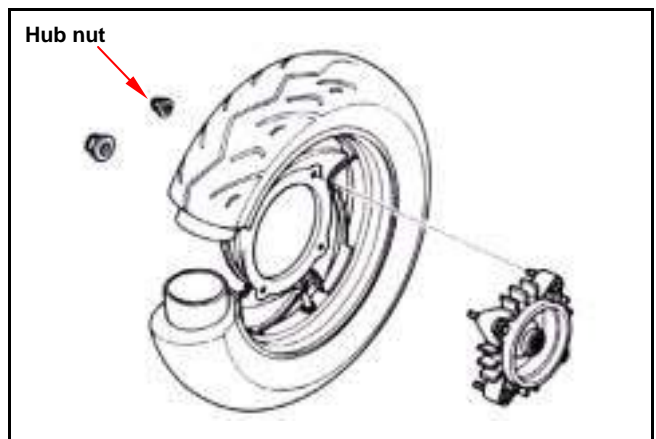

14. REAR WHEEL/SUSPENSION

Installation

Install the rear wheel and tighten the nut.

Tighten torque: 11.0kgf-m

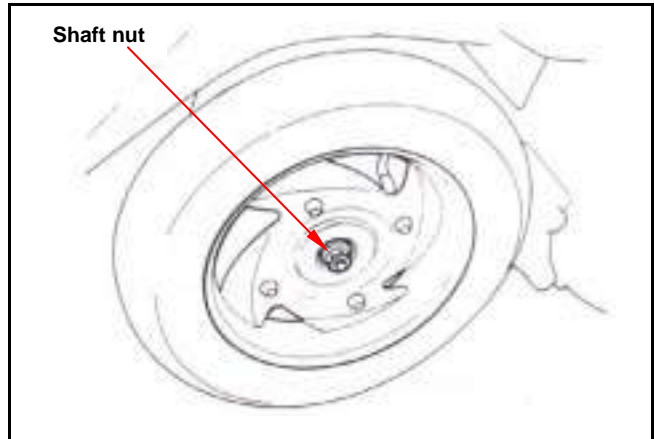

Install exhaust pipe & muffler.

Tighten torque (bolt): 3.3kgf-m

Tighten torque (nut): 1.2kgf-m

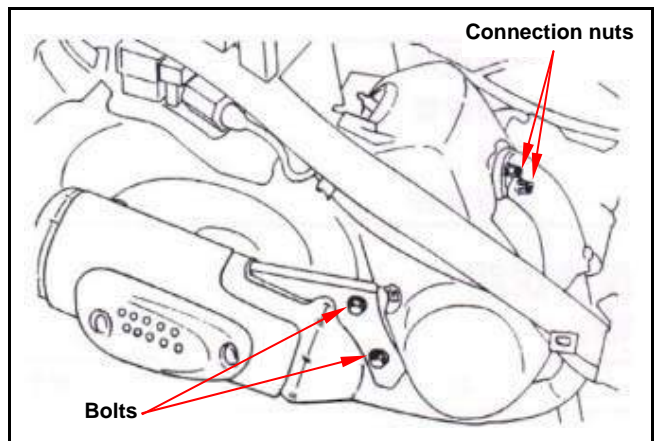

Rear Shock Absorber

Removal

Remove body cover.

Remove air cleaner.

Remove rear shock absorber upper & lower bolts.

Remove rear shock absorber.

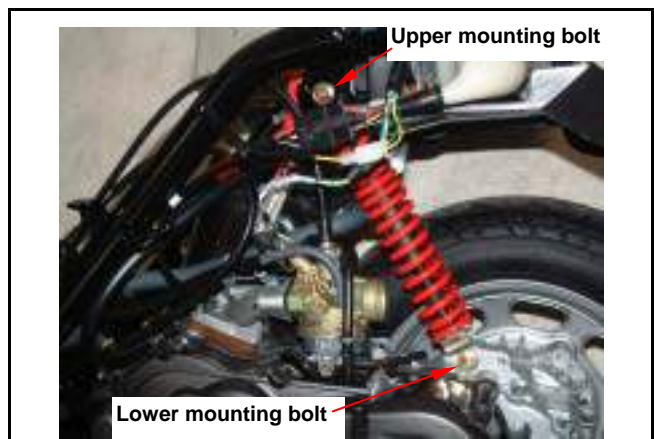

Installation

Install the rear shock absorber.

Tighten the upper & lower mounting bolts to specified torque.

Torque value:

Upper mounting bolt: 4.0kgf-m

Lower mounting bolt: 2.7kgf-m

Press down the tail of the scooter for several times to check shock absorber operation.

Installation all components in reverse order of removal procedures.

Install air cleaner.





15. ELECTRICAL EQUIPMENT

Maintenance Information	15-2	Starting System	15-12
Troubleshooting	15-3	Oil Level Switch	15-14
Battery	15-4	Fuel Unit	15-15
Charging System	15-5	Switch/Horn	15-16
Ignition System	15-9	Bulb Replacement	15-18

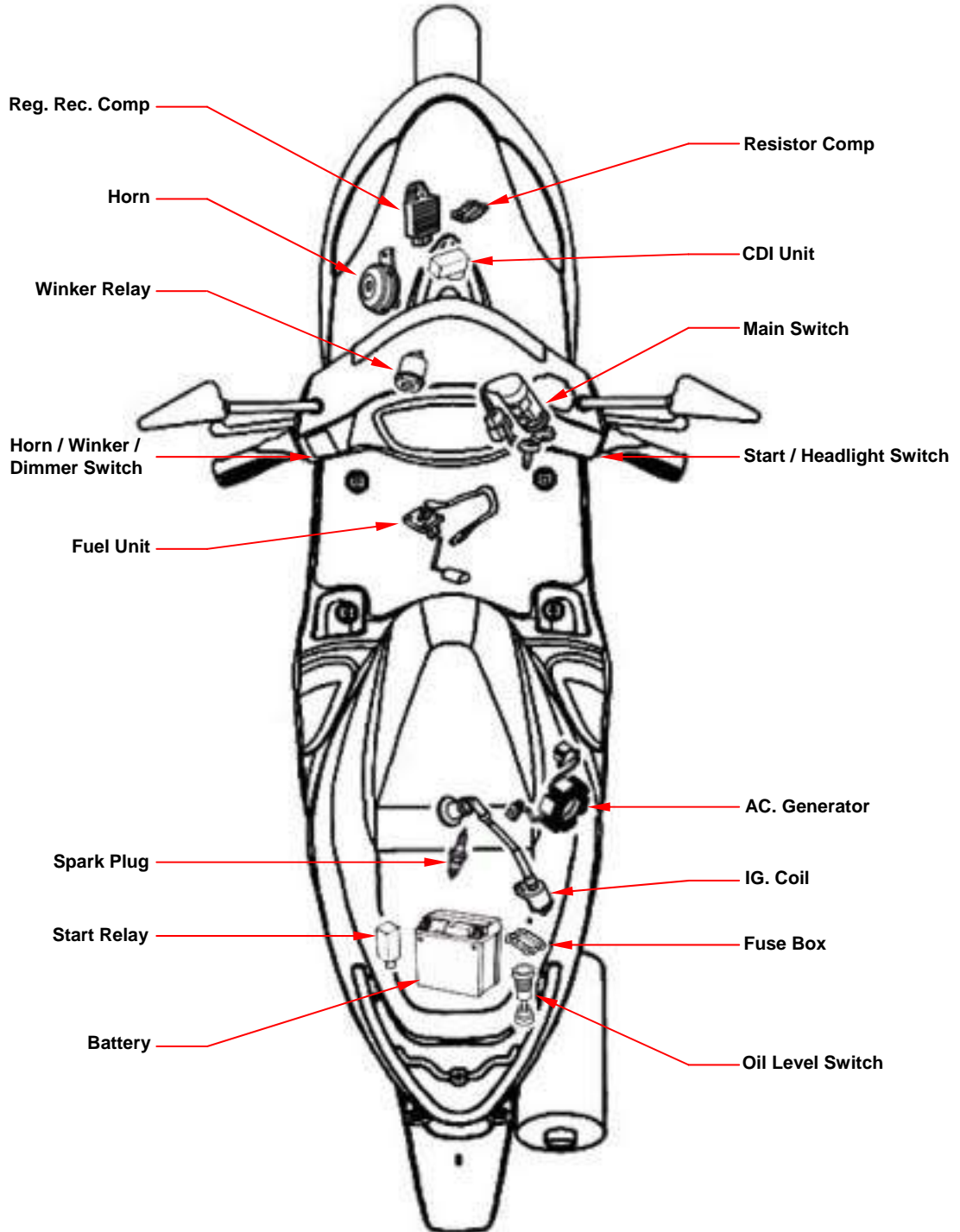

15. ELECTRICAL EQUIPMENT

Maintenance Information

Precautions in Operation

- When remove the battery, the disconnection sequence of cable terminals shall be strictly observed. (First disconnect the negative cable terminal, next, the positive cable terminal.)
- The model of the spark plug and the tightening torque.
- The ignition timing.
- Adjustment of headlight.
- Removal and installation of AC generator.
- The maintenance-free battery requires no inspection of electrolyte level and refilling of distilled water.
- To recharge the battery, remove the battery from the motorcycle without removing ventilation caps.
- Unless in emergency, never rapid charge the battery.
- The voltage must be checked with the voltmeter while charging the battery.
- As C.D.I assembly does not require an ignition timing check. In case ignition timing is incorrect, check C.D.I and AC generator. Verify with an ignition timing light after replacement if necessary.
- The starter motor can be removed after the engine is removed.

Specification

Charging System

Item		Specification
Battery	Capacity	12V3Ah
	Charging rate	0.4A / 5 hours (standard), 4A / 0.5 hour (fast charging)
Leak current		< 1 mA
Charging current		1.2 A / 5000 rpm
Control voltage in charging		14.0 ~ 15.0 V / 5000 rpm
Control voltage in headlight		12.6 ~ 13.6 V / 5000 rpm

Ignition System

Item		Specification
Spark plug	Model	NGK BR8HSA (Recommended)
	Gap	0.6 ~ 0.7 mm
Ignition coil and resistance	Primary coil	0.19 ~ 0.23 Ω
	Secondary coil	2.8 ~ 3.4 K Ω
Ignition timing	"F" mark	17° BTDC / 1800 rpm

Troubleshooting

No voltage

- Battery discharged
- The cable disconnected
- The fuse is blown
- Improper operation of the main switch

Low voltage

- The battery is not fully charged
- Poor contact
- Poor charging system
- Poor voltage regulator

No spark produced by spark plug

- The spark plug is out of work
- The cable is poorly connected, open or short-circuited
 - Between AC.G. and C.D.I.
- Poor connection between C.D.I. and ignition coil
 - Poor connection between C.D.I. and the main switch
- Poor main switch
- Poor C.D.I.
- AC.G. is out of work

Starter motor does not work

- The fuse is blown
- The battery is not fully charge
- Poor main switch
- Poor starter switch
- The front and rear brake switches do not operate correctly
- Starter relay is out of work
- The ignition coil is poorly connected, open or short-circuited
- The starter motor is out of work

Intermittent power supply

- The connector of the charging system becomes loose
- Poor connection of the battery cable
- Poor connection or short-circuit of the discharging system
- Poor connection or short-circuit of the power generation system

Charging system does not operate properly

- Burnt fuse
- Poor contact, open or short circuit
- Poor regulator
- Poor ACG

Engine does not crank smoothly

- Primary coil circuit
 - Poor ignition coil
 - Poor connection of cable and connectors
 - Poor main switch
- Secondary coil circuit
 - Poor ignition coil
 - Poor spark plug
 - Poor ignition coil cable
 - Current leakage in the spark plug cap
- Incorrect ignition timing
 - Poor AC.G.
 - Improper installation of the pulse sensor
 - Poor C.D.I.

Weak starter motor

- Poor charging system
- The battery is not fully charged
- Poor connection in the windings
- The motor gear is jammed by foreign material

Starter motor is working, but engine does not crank

- Poor starter motor pinion
- The starter motor run in reverse direction
- Poor battery

15. ELECTRICAL EQUIPMENT

Battery

Battery Removal/Installation

Turn off main switch.

Open seat.

Remove screw and the open battery cover.

Disconnect the negative cable terminal first, then the positive cable terminal.

Remove the battery from the scooter.

Install the battery in reverse order of removal.

Voltage Check

Open seat and battery cover.

Remove wires from battery.

Check battery voltage.

Voltage:

Fully charged: 13.0 ~ 13.2V

Undercharged: 12 V

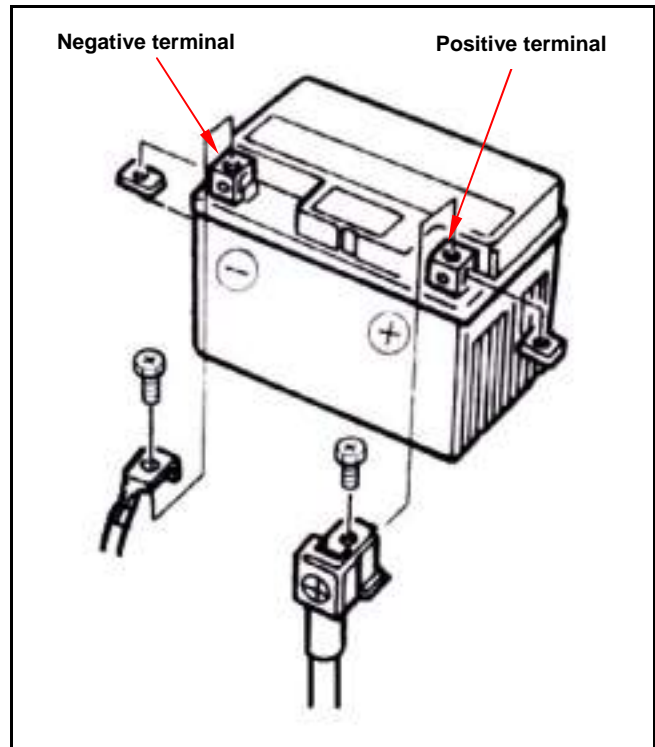

Charging

Remove the battery.

Connect the positive terminal (+) of the charger to the battery positive terminal (+).

Connect the negative terminal (-) of the charger to the battery negative terminal (-).

Standard charging current/time: 0.4A/5 hrs.

Fast charging current/hrs: 4A/0.5 hr.

Caution

Strictly keep flames and sparks away while recharging to avoid to explosion causing by hydrogen.

Stop charging battery when electrolyte temperature is over 45 (117).

Caution

Fast charging the battery is for in emergency only. Battery should be charged in standard.

Charging System

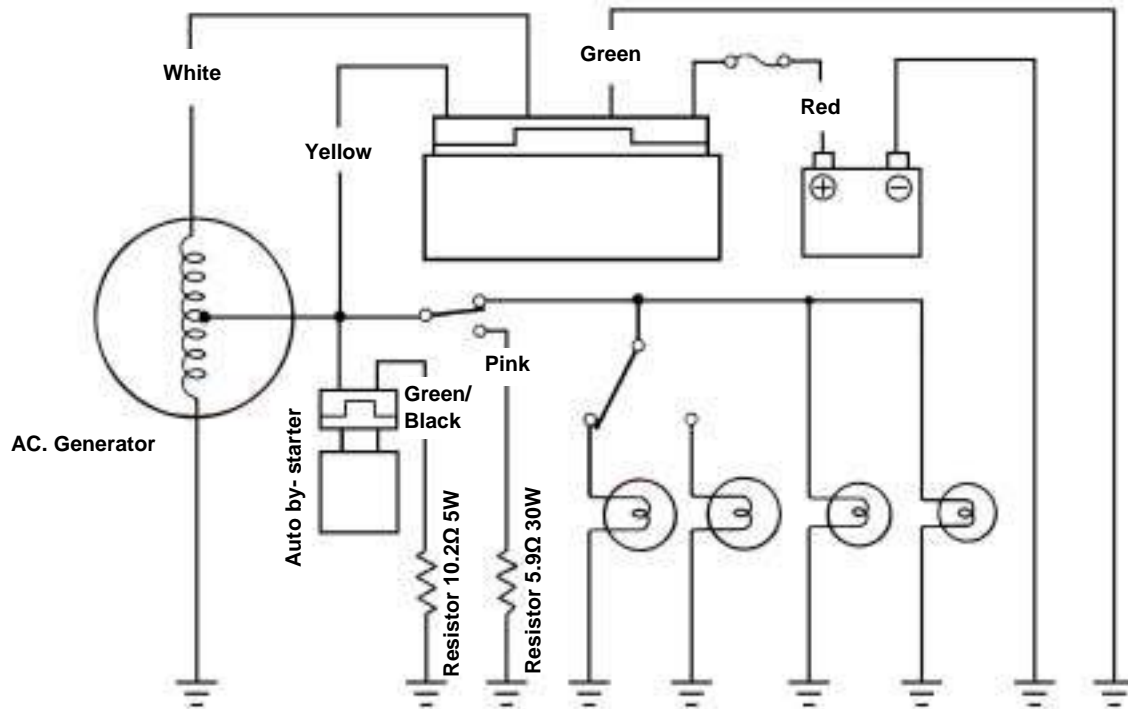

Current Leakage Inspection

Turn the main switch to OFF position, and remove the negative cable terminal (-) from the battery.

Connect an ammeter between the negative cable terminal and the battery negative terminal.

⚠ Caution

- In the current leakage test, set the current range at larger scale, then gradually decrease to the lower scale as the test process goes to avoid possible damage to the ammeter and the fuse.
- Do not turn the main switch to ON position during test.

If the leaked current exceeds the specified value, it may indicate a short circuit.

Allowable current leakage: Less than 1mA

Disconnect each cable one by one and take measurement of the current of each cable to locate the short circuit.

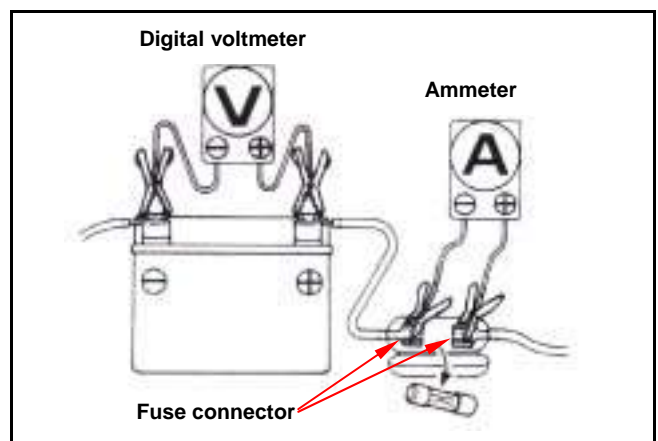
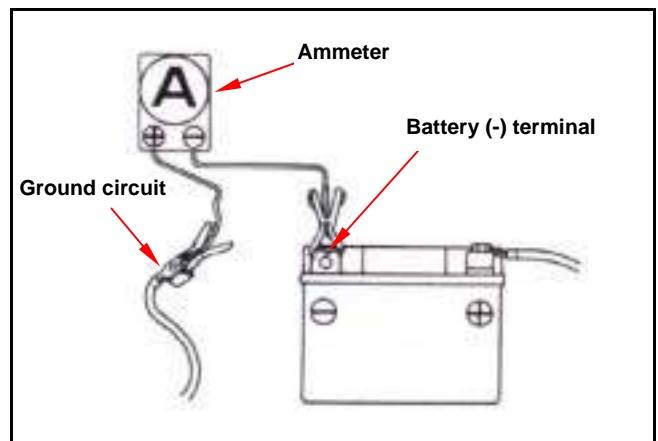

15. ELECTRICAL EQUIPMENT

Charging Voltage Inspection

Caution

- Before conducting the inspection, be sure that the battery is fully charged. If undercharged, the current changes dramatically.
- Use a fully charged battery having a voltage larger than 13.0 V
- While starting the engine, the starter motor draws large amount of current from the battery.

After the engine is warmed up, replace original battery with a fully charged battery. Connect a digital voltmeter to the battery terminals. Connect an ammeter between both ends of the main fuse.

Caution

When the probe is reversibly connected, use an ammeter having an indication that shows both positive and negative direction current. The measurement would be at zero, if the ammeter is one direction only.

Caution

- Do not use short-circuit cable.
- It is possible to measure the current by connecting an ammeter between the battery positive terminal and the + cable position terminal, however, while the starter motor is activated, the surge current of the motor draws from the battery may damage the ammeter. Use the kick starter to start the engine.
- The main switch shall be turned to OFF position during the process of inspection. Never tamper with the ammeter and the cable while there is current flowing through. It may damage the ammeter.

Connect a tachometer.

Turn on the headlight to high beam and start the engine.

Accelerate the engine to the specified revolution per minute and measure the charging voltage.

Specified Charging Current: 1.2 A / 5000 rpm

Control Charging Voltage: 14.0~15.0 V / 5000 rpm

Caution

To replace the old battery, use a new battery with the same current and voltage.

The following problems are related to the charging system, follow the instructions provided in the checking list to correct it if any one of the problems takes place.

- (1) The charging voltage can not exceed the voltage between two battery terminals and the charging current is in the discharging direction.
- (2) The charging voltage and current are too much higher than the standard values.

The following problems are not related to the charging system; correct it if any by following steps indicate in the checking list.

- (1) The standard charging voltage and current can only reach when the revolution of the engine exceeds the specified rpm.
 - Bulbs used exceed their rate and consume too much power.
 - The replacement battery is aged and does not have enough capacity.
- (2) The charging voltage is normal, but the current is not.
 - The replacement battery is aged and does not have enough capacity.
 - Battery used do not have enough electricity or is over charged.
 - The fuse of the ammeter is blown.
 - The ammeter is improperly connected.
- (3) The charging current is normal, but the voltage is not.
 - The fuse of the voltmeter is blown.

Headlight Voltage Inspection

Connect a tachometer.

Do not disconnect the headlight harness connector after engine started.

Turn the headlight ON and to high beam position.

Measure the voltage between the blue wire (+) and green wire (-) while the headlight harness is still in connection. Measure alternating current voltage with a voltmeter.

Gradually increase engine speed and read the voltage in each specified rpm.

Control voltage: 12.0~14.0 V / 5000 rpm

Resistance Measurement of Resistor at 20 .

Resistor (10.2 5W) Green/Black and Body ground: 9.0 ~10.0

Resistor (5.9 5W) Pink and Body ground: 5.6 ~6.2

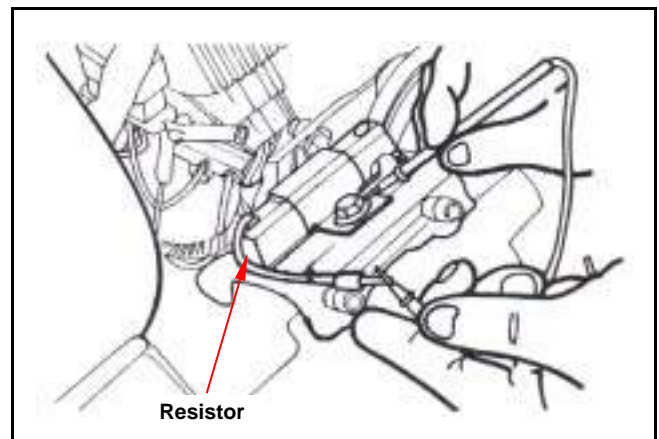
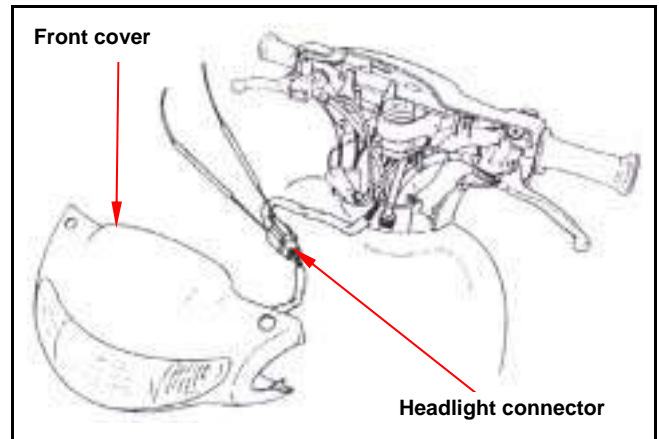

15. ELECTRICAL EQUIPMENT



Voltage Regulator Inspection

Check the each pins of connector on the voltage regulator.

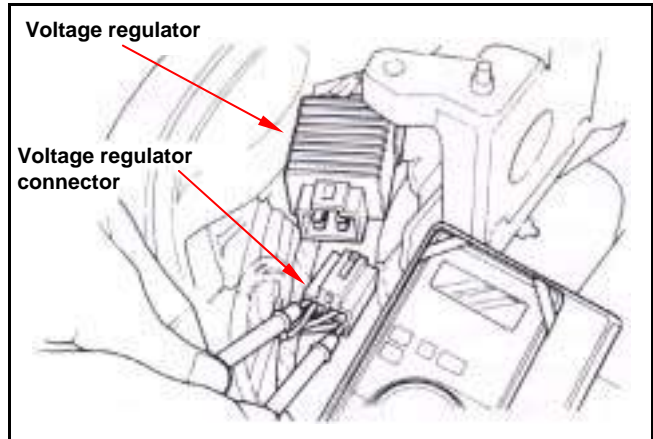

Inspection	Probable cause
Check voltage between battery terminal (red) and ground (green).	Blown fuse or poor main switch contact
Check continuity between ground and frame.	Open-circuit wire
Check charging coil (white to ground) if its resistance is within 0.2~1.0	Open-circuit in alternator charging coil or in illumination switch.
Check charging /illumination coil (yellow to ground) if its resistance is within 0.2~0.8	

If wire circuit check is in normal and there is no loose in the pins of voltage regulator connector, then measure the resistance among pins on the connectors of voltage regulator.

Voltage Regulator

Multi-meter(+) Multi-meter (-)	White A	Yellow L	Red B	Green E
White A			4~7	
Yellow B				2.4~4.8
Red B	4~7			
Green E		2.4~4.8		

If the resistance values are abnormal among the pins, replace the voltage regulator.

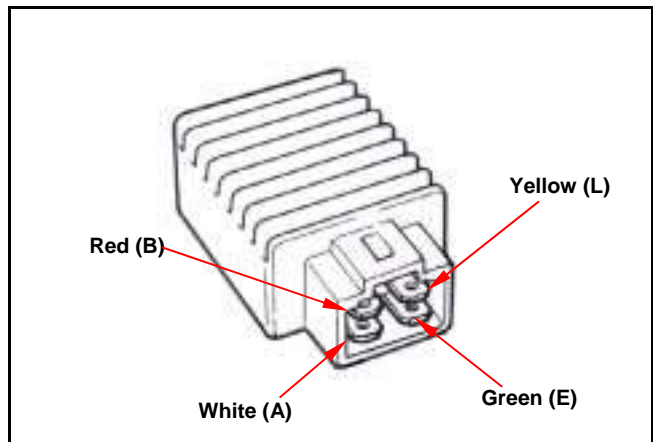

⚠ Caution

- If the probe is touched by finger, then the resistance values will be incorrect.
- It contains semi-conductor in circuit so the measured resistance value will be in different if different testers are used. Thus, these values cannot be judged with standards.

AC Generator Inspection

Remove body cover.
Disconnect the generator harness connector.
Measure the resistance on both charging coil (the white to ground) and illumination coil (the yellow to ground).

Resistance Measurement: (20)

Charging coil (white - green): 0.2~1.0

Illumination coil (yellow - green): 0.1~0.8

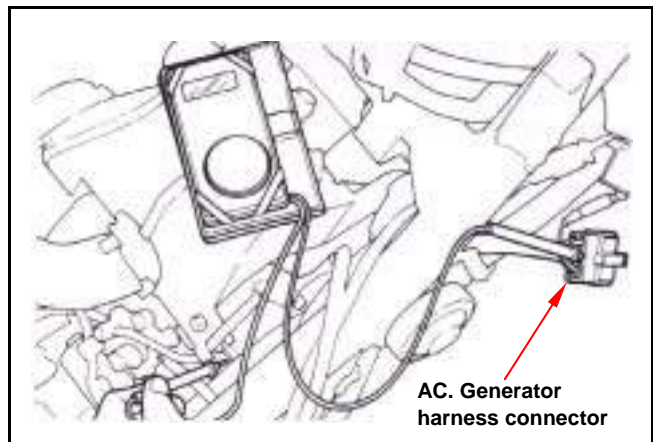

Ignition System

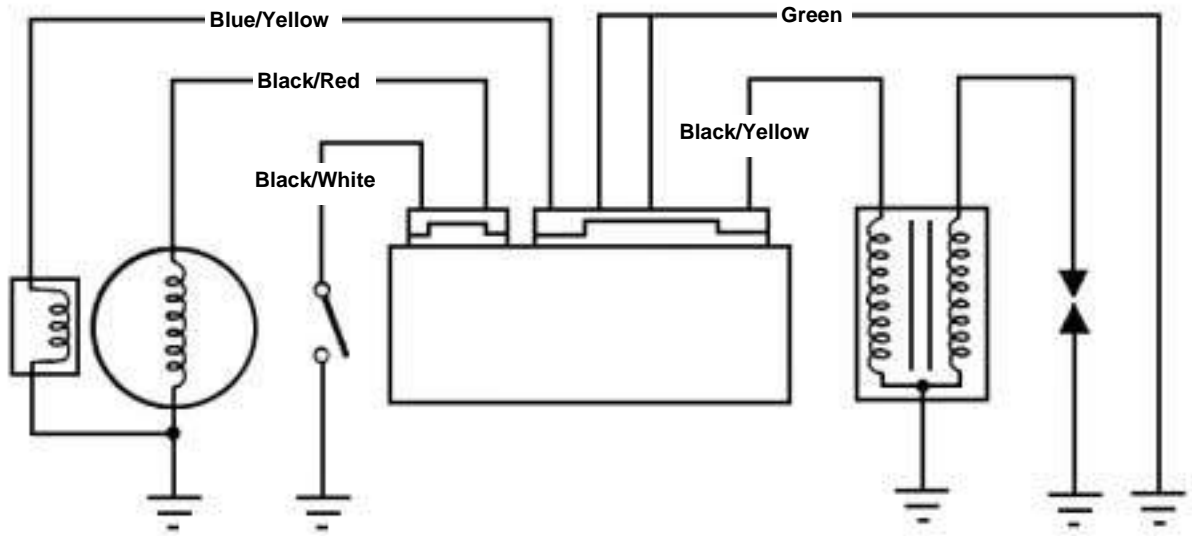

15. ELECTRICAL EQUIPMENT

Ignition Coil Inspection

- Remove body cover.

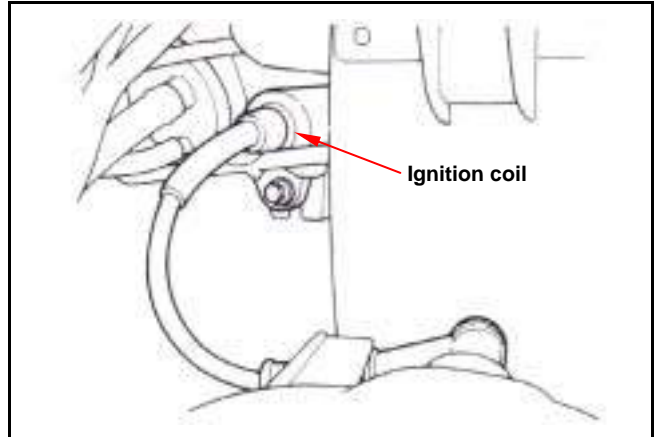

Measure the primary coil resistance.

Resistance : 0.19~0.23K (A) (B)

Measure the secondary coil resistance.

Resistance : 8.2~9.3K (A) (C)

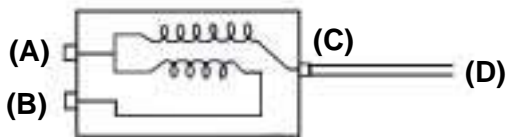
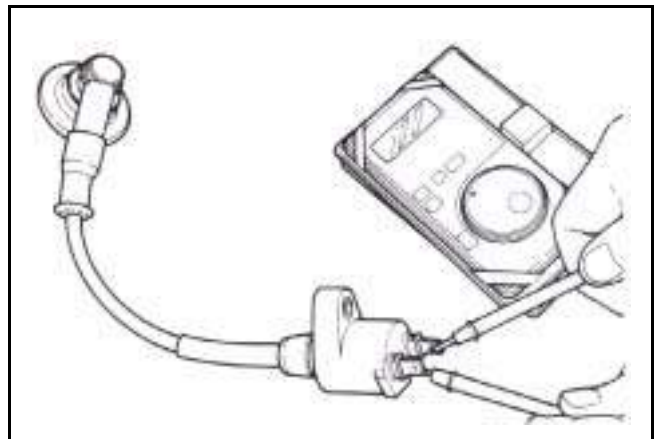

Remove the high voltage coil cap, and measure its negative (-) terminal for the secondary coil resistance.

Resistance : 3.1~3.2K (A) (D)

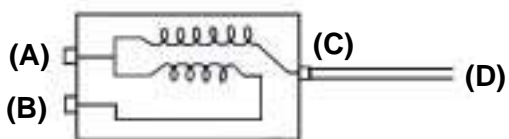
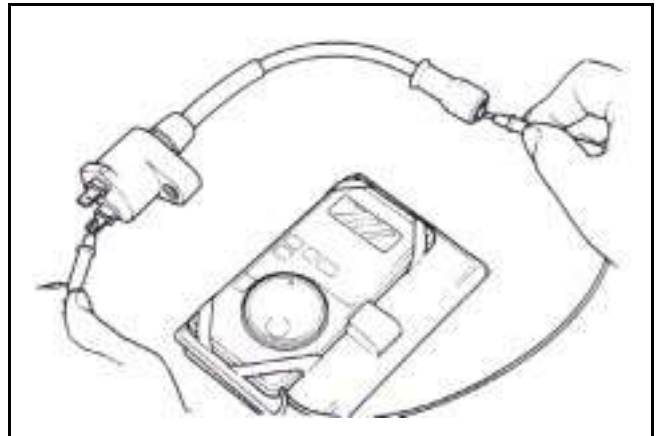

Electrical System Circuit Inspection

Pulse Generator / Exciting Coil

Remove body cover.

Disconnect alternator connector.

Resistance Measurement: (20 °C)

Pulse generator coil (blue/yellow - ground):
50~200

Exciting (yellow - ground): 400~800

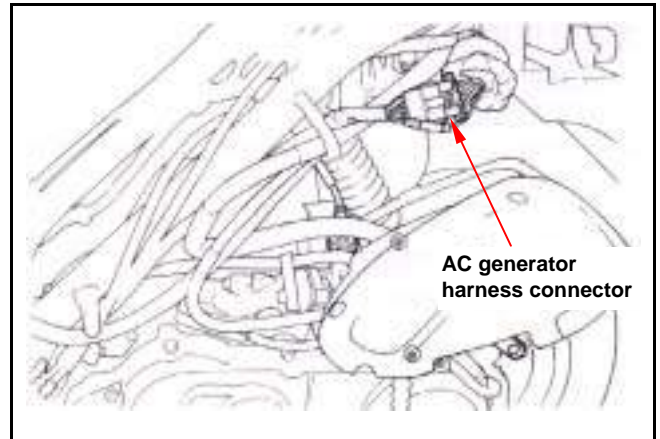

CDI Electrical System Circuit Inspection

Remove front cover.

Disconnect the CDI set connector, and check its circuit to diagnosis related ignition components.

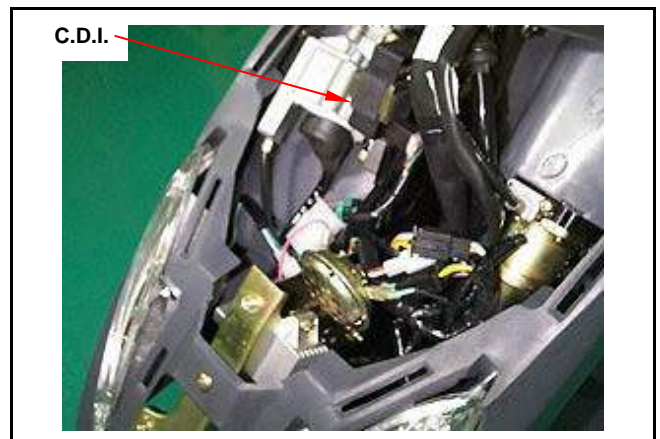

CDI Electrical System Circuit Inspection

ITEM		Measure at:	Standard (at 20 °C)
Main Switch		Black/white-green	Continuity as main switch OFF
Exciter Coil		Black/Red-Green	400 ~800Ω
Pulse Generator		Blue/Yellow-green	50 ~200Ω
Ignition Coil	Primary	Black/yellow-green	0.21Ω±10%
	Secondary	Green-high voltage cable -w/o Cap	3~5KΩ
		Green-high voltage cable - w/ Cap	7~12KΩ

- If above checks are in normal but spark plug is still no spark. Then it probable causes from CDI set or high voltage coil.
- If abnormal circuits are found in above checks, at first check all items, and then check each item one by one.

15. ELECTRICAL EQUIPMENT

Starting System

Starter Relay Inspection

Remove luggage box.

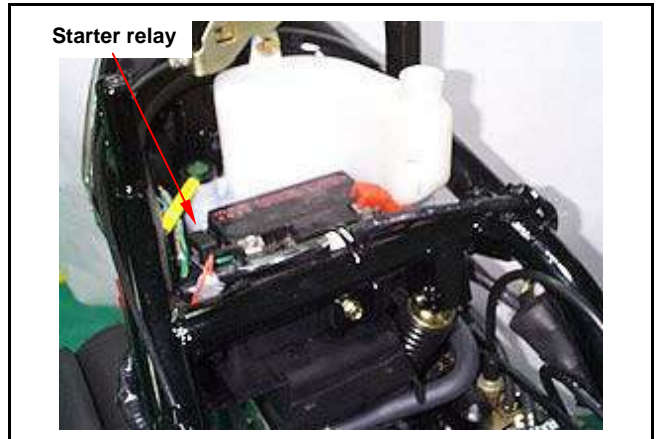

Connect both the green/yellow (-) and the yellow/red (+) pins to battery posts directly. If the red and red/white pins are also in continuity, it means it is in normal.

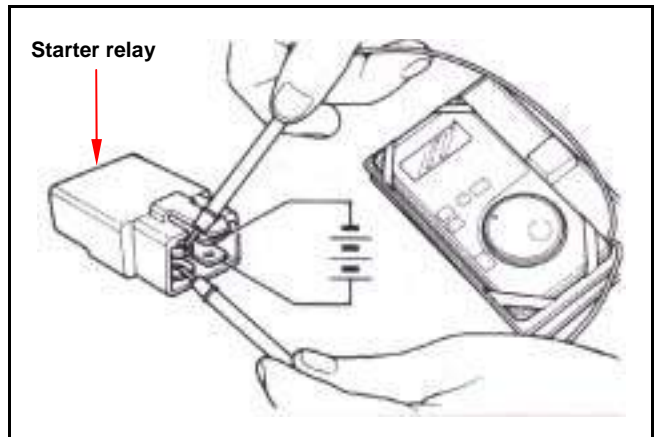
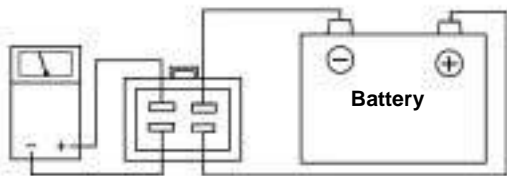

Starter Motor Pinion Removal /

Installation

Remove left crankcase cover.

Remove starter motor pinion.

Install the starter motor pinion in reverse order of removal.

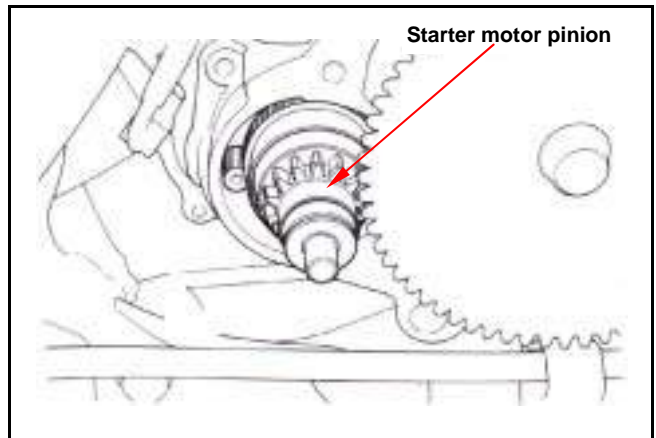

Starter Motor Pinion Inspection

- Pinion, reduction gear for wear out or damage replace it with new one.
- Gear journal for wear out or damage replace it with new one.

Check the pinion for sliding in axial direction smoothly.

- The pinion sliding in axial direction not in smooth replace it with new one.

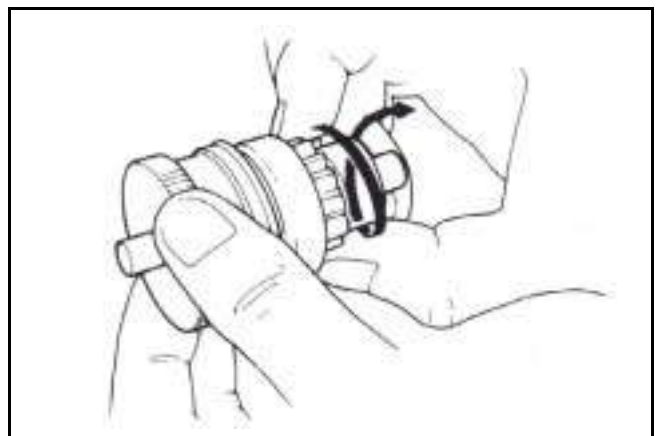

Starter Motor Removal / Disassembly

- Remove body cover.
- Remove bolt and oil pump control cable.
- Disconnect starter motor harness connector.
- Remove 2 bolts for separation starter motor and gasket.
- Remove 2 bolts for disassembly the starter motor.

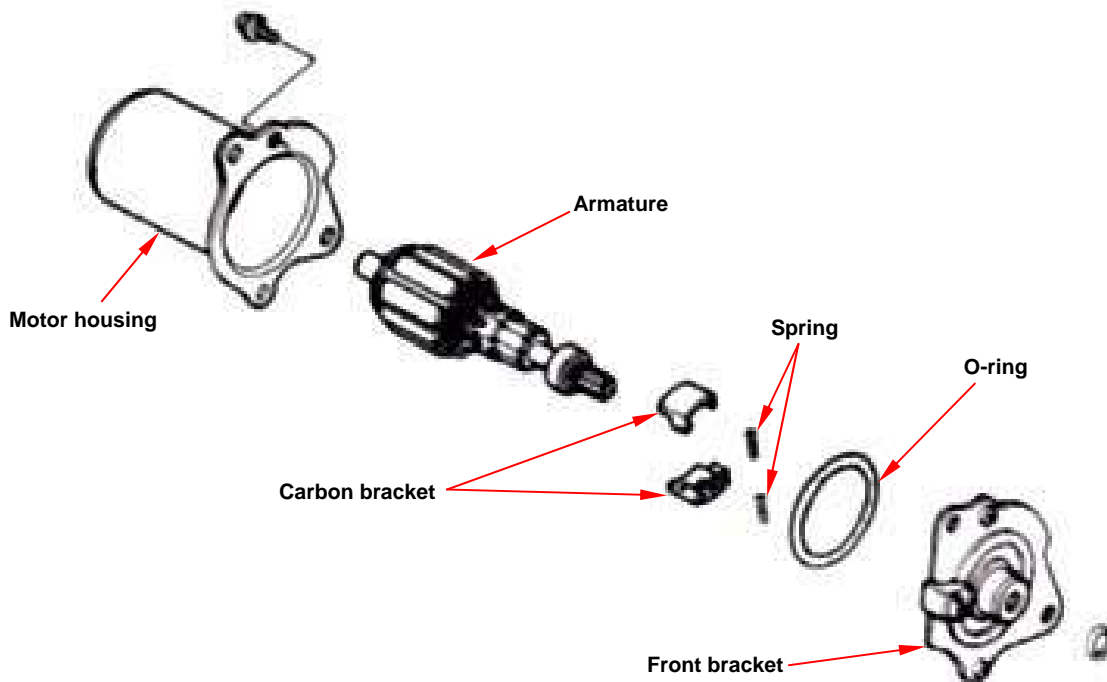
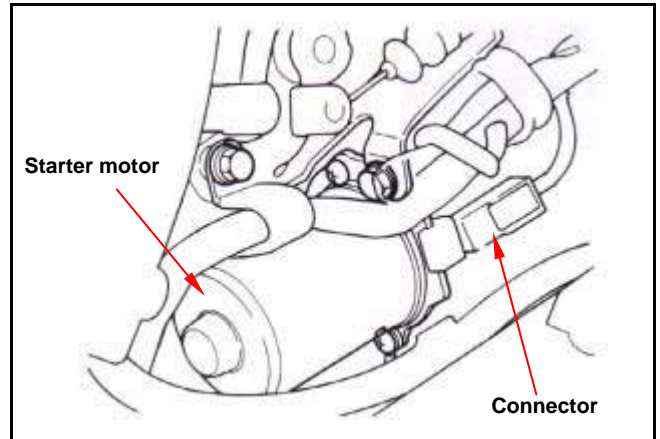

Armature Inspection

Check the armature for discoloration or other damage. It may be short-circuit if dark surface on the shifter found.

Caution

Do not clean the shifter surface with sandpaper.

Check continuity 1) both the shifter surface and shaft, 2) among the shifter surfaces. It can be in continuity among the shifter surfaces, but both the shifter surface and the shaft can not be in continuity.

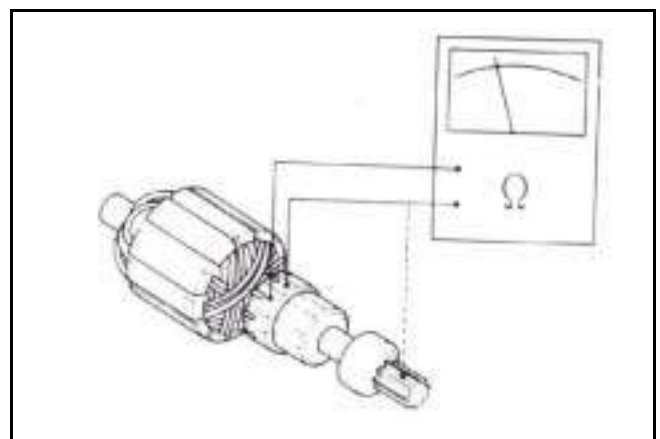

Starter Motor Re-Assembly / Installation

Re-assemble and install the starter motor in reverse order of removal procedures.

15. ELECTRICAL EQUIPMENT

Oil Level Switch

Troubleshooting

- If the oil level in oil tank is in specified level, but the oil level indicator still goes on.
 - Remove body cover.
 - Disconnect oil gauge wire, and turn the main switch to ON position.

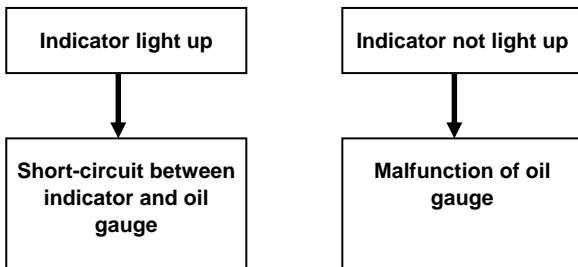

- If there is no oil in oil tank or low oil level, but the oil level indicator still not goes on.
 - Remove body cover.
 - Disconnect oil gauge wire and connect a jump wire among connector, and then turn the main switch to ON position.

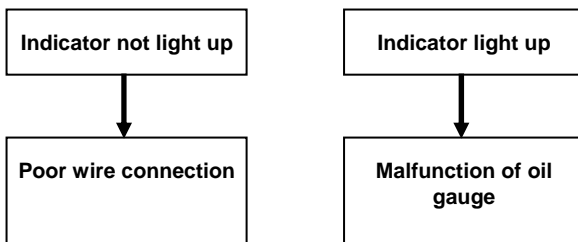

- Disconnect oil gauge connector, and check voltage between wire and ground.

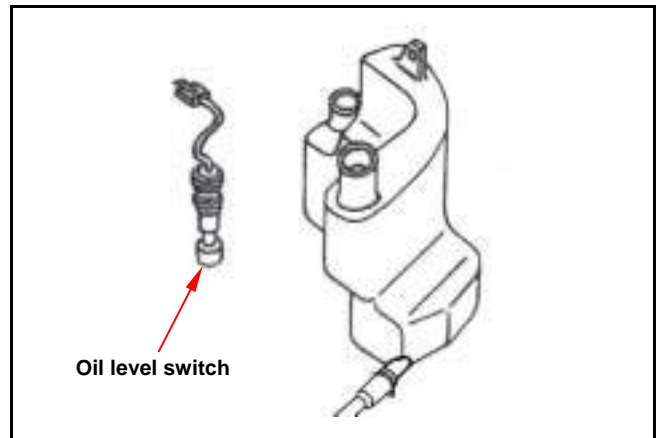
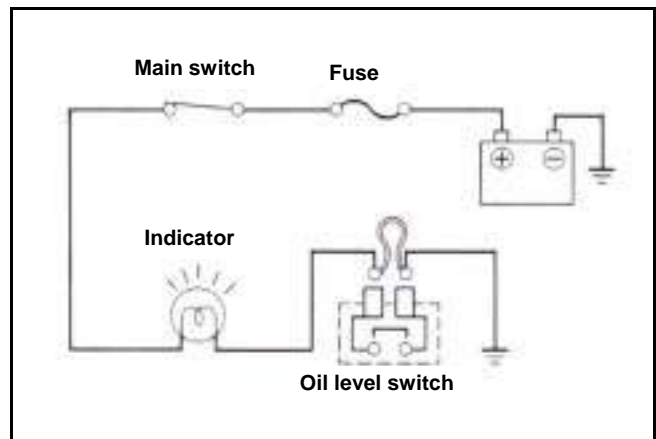
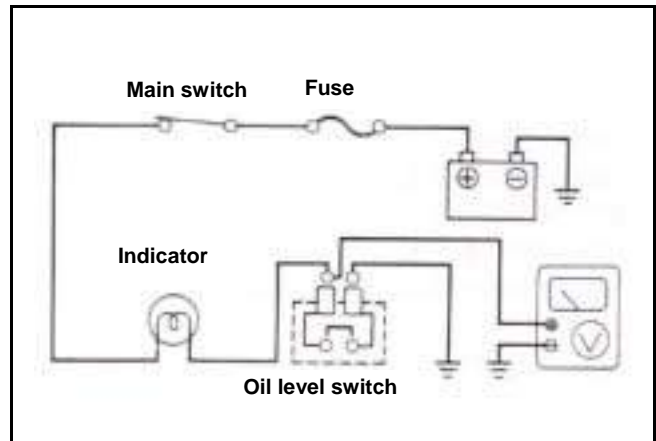
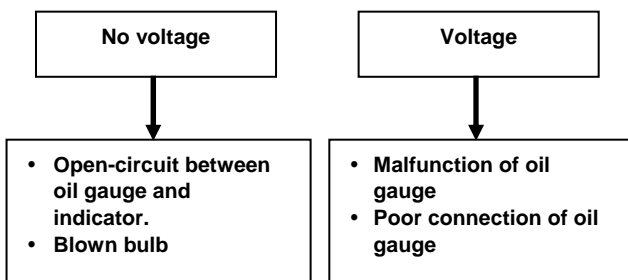

Removal / Installation

Remove oil tank.

Remove oil level switch from the oil tank.

Install the oil level switch in reverse order of removal procedures.

Fuel Unit

Removal / Installation

Remove 4 bolts and floor panel.
 Disconnect fuel unit connector.
 Remove the fuel unit plastic cap.
 Turn the snap ring in CCW direction and then remove the fuel unit.

⚠ Caution

Do not bend the float arm.

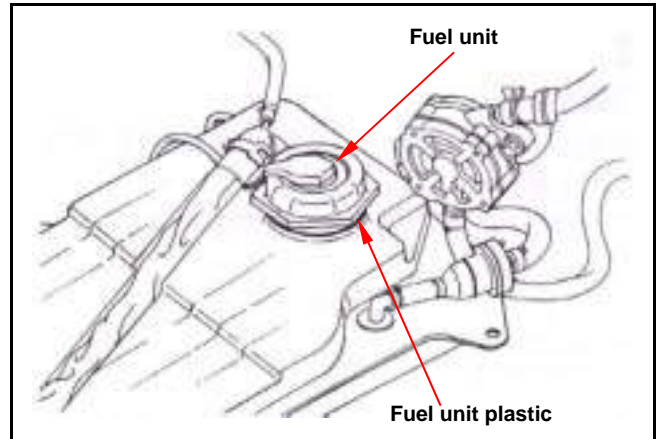

Install in reverse order of removal procedures.
 Remark: Aligning the slot of fuel unit with the ring of oil tank as installation, and then turn the snap ring in CW direction until matching to the arrow.

Inspection

1. Connect the fuel unit connector.
 Turn the main switch ON.
 Move the float in up and down, and make sure that the fuel indicator can be reached to F (Full) and E (Empty) positions.
 Conduct the step 2 if the needle on the fuel indicator is not moved.
2. Measure the connector resistance while the float in up and down positions.

Float position	Resistance value
Up (full)	3~10
Down (empty)	90~100

Check the fuel indicator if the resistance is in normal.

Replace the fuel gauge if the resistance is abnormal.

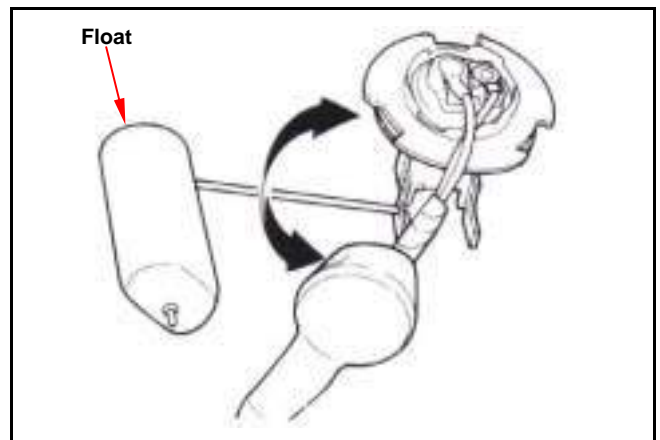

15. ELECTRICAL EQUIPMENT

Switch / Horn

Remove handle covers and front cover.
 Remove main switch cover.
 Remove front inner box.
 Check continuity on each switch.
 The connected circles with a line are that they should be in continuity.

Main Switch

Wire color	Black	Black / White	Green	Red
Mark	BAT2	IG	E	BAT1
LOCK		● — ●		
OFF		● — ●		
ON	● —			● —

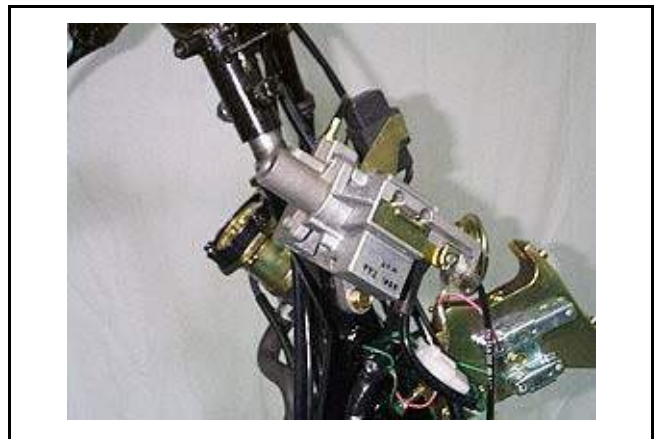
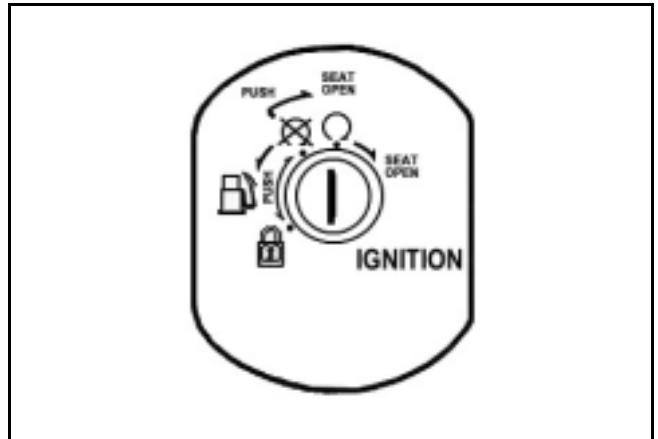

Winker light switch

Wire color	Gray	Light blue	Orange
Mark	WR	R	L
R	● — ●		
N			
L	● —		● —

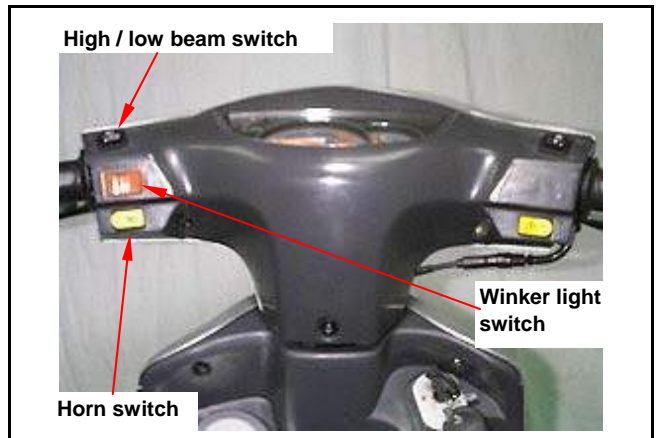

Horn Switch

Wire color	Light green	Black
Mark	HO	BAT2
FREE		
PUSH	● — ●	

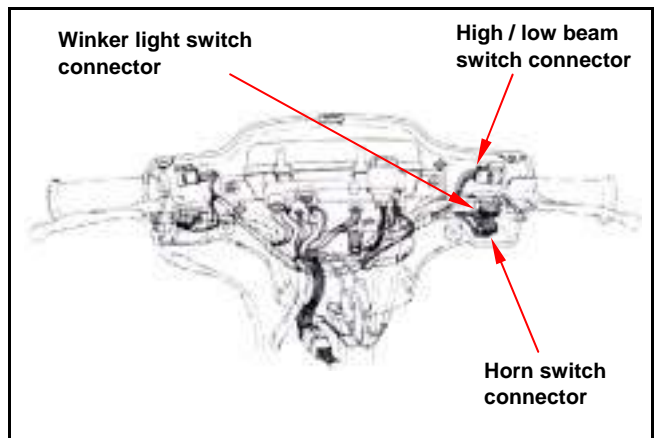

High/Low Beam switch

Wire color	Brown	White	Blue
Mark	HL	LO	HI
LO	● — ●		
(N)	● — ●	● — ●	● — ●
HI	● —		● —



15. ELECTRICAL EQUIPMENT

Headlight Switch

Wire color	Brown	Yellow	Pink
Mark	HL	CI	RE
OFF		●	●
ON	●	●	

Starter Switch

Wire color	Yellow / Red	Green
Mark	ST	E
FREE		
PUSH	●	●

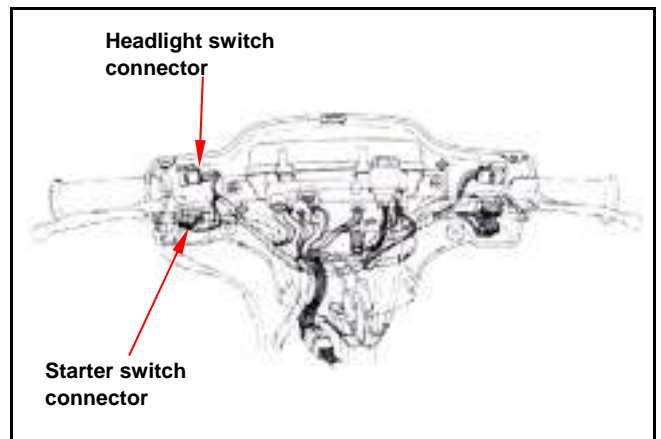

Front / Rear Brake Light Switch

If the switch is in continuity as braking, it is in normal. The switch is non-adjustable.

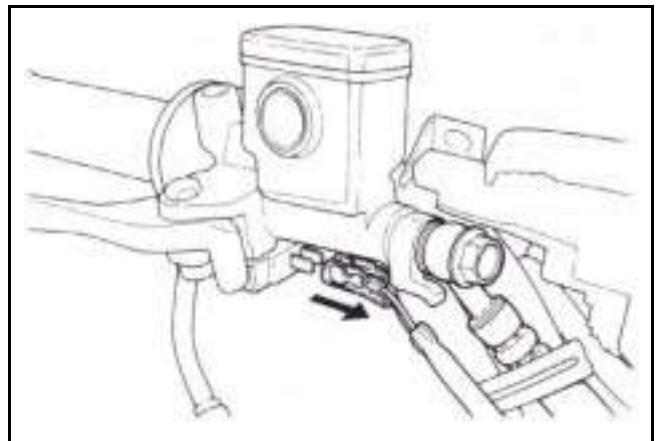

Horn

If the horn give out sound as connecting to 12V battery, it means that it is in normal.

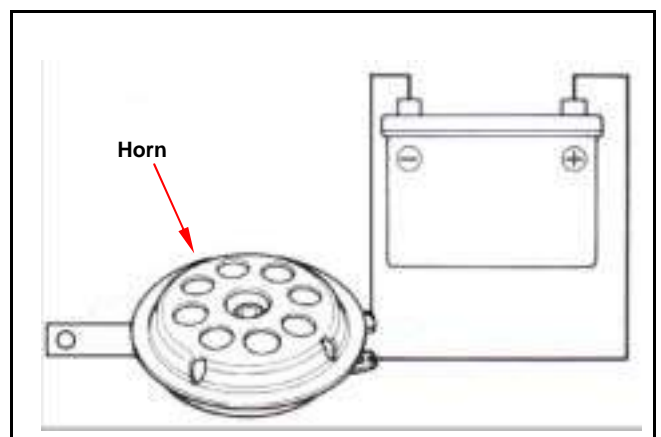

15. ELECTRICAL EQUIPMENT

Bulb Replacement

Headlight

Remove handle front cover.
 Remove bulb seat and replace the bulb.
 Install the all removed parts.

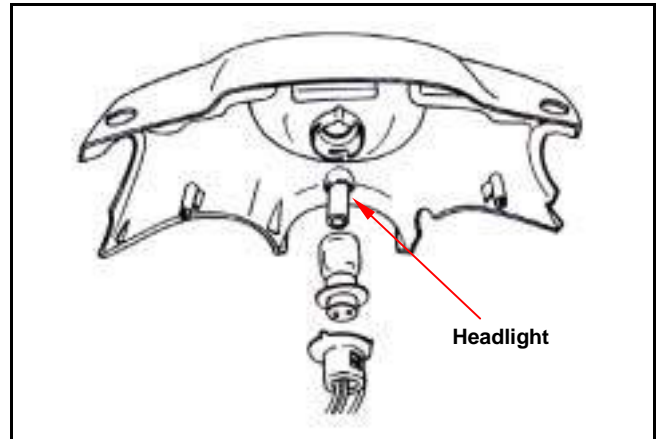

Front winker light

Remove front cover.
 Remove front winker light lens.
 Replace front winker light bulb.
 Install the all removed parts.

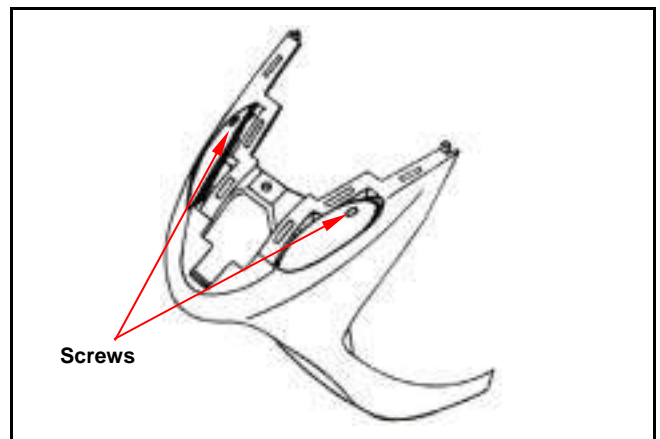

Tail light / Brake light / Rear winker light

Remove 2 screws and then remove outer cover.
 Remove 2 screws and then remove inner cover.
 Replace tail light or winker light bulb.
 Install the all removed parts.



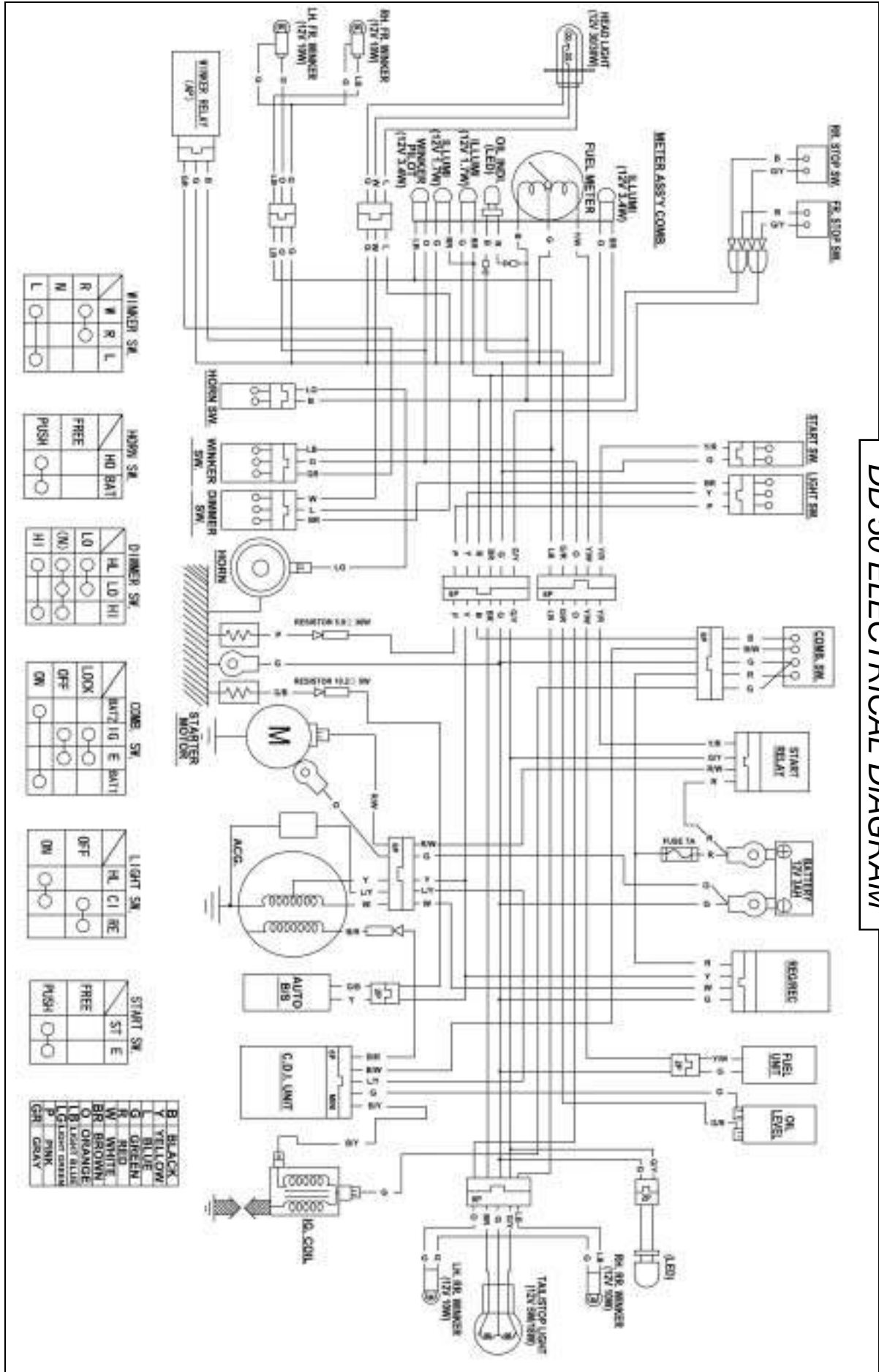

DD 50 ELECTRICAL DIAGRAM

16. ELECTRICAL DIAGRAM

Notes: